

Birla Central Library

PILANI (Jaipur State)

Engg. College Branch

Class No - 624.2

Book No - H796M

Accession No - 32494

Acc. No. 32494

ISSUE LABEL

Not later than the latest date stamped below.

--	--	--

MOVABLE AND LONG-SPAN
STEEL BRIDGES

Books by **GEORGE A. HOOL**

HOOL—Reinforced Concrete Construction

Volume I—Fundamental Principles

Volume II—Retaining Walls and Buildings

Volume III—Bridges and Culverts

With **CHARLES S. WHITNEY**

HOOL AND WHITNEY—Concrete Designers' Manual

With **NATHAN C. JOHNSON**

HOOL AND JOHNSON—Concrete Engineers' Handbook

HOOL AND JOHNSON—Handbook of Building Construction

Two Volumes.

With **W. S. KINNE**

HOOL AND KINNE—Foundations, Abutments and Footings,
2d ed.

HOOL AND KINNE—Structural Members and Connections,
2d ed.

HOOL AND KINNE—Stresses in Framed Structures, 2d ed.

HOOL AND KINNE—Steel and Timber Structures, 2d ed.

**HOOL AND KINNE—Reinforced Concrete and Masonry
Structures, 2d ed.**

HOOL AND KINNE—Movable and Long-span Steel Bridges,
2d ed.

With **H. E. PULVER**

HOOL AND PULVER—Concrete Practice

HOOL AND PULVER—Reinforced Concrete Construction

Volume I—Fundamental Principles, Fourth Edition

MOVABLE AND LONG-SPAN STEEL BRIDGES.

Compiled by a Staff of Specialists

EDITORS-IN-CHIEF

GEORGE A. HOOL, S. B.

*Consulting Engineer, formerly Professor of Structural Engineering
The University of Wisconsin*

AND

W. S. KINNE, B. S.

*Professor of Structural Engineering
The University of Wisconsin*

REVISED BY

R. R. ZIPPRODT, B. S., M. AM. SOC. C. E.

*Principal Civil Engineer, Office of The Quartermaster General
Washington, D. C.*

*Formerly Associate Professor of Civil Engineering
Columbia University*

AND

H. E. LANGLEY

*Bridge Engineer, New Hampshire State Highway Department
Concord, New Hampshire*

SECOND EDITION

THIRD IMPRESSION

McGRAW-HILL BOOK COMPANY, Inc.

NEW YORK AND LONDON

1943

MOVABLE AND LONG-SPAN STEEL BRIDGES

COPYRIGHT, 1924, 1943, BY THE
MCGRAW-HILL BOOK COMPANY, INC.

PRINTED IN THE UNITED STATES OF AMERICA

*All rights reserved. This book, or
parts thereof, may not be reproduced
in any form without permission of
the publishers.*

THE MAPLE PRESS COMPANY, YORK, PA.

PREFACE TO THE SECOND EDITION

This, the Second Edition of this volume—one of the six in the Structural Engineers' Handbook Library—has been designed to provide both the practicing engineer and the student with a reference work in which problems relating to the design and construction of the various types of movable long-span steel bridges are thoroughly covered.

All errors of which there is any record have been corrected. The senior author of the present revision will be grateful to readers who bring any other errors that may be found to his attention for future correction.

Some of the major additions that have been made to the First Edition are noted here. Section 1 on Bascule Bridges has been supplemented by matter dealing with recent developments in bascule bridge design; permissible unit stresses in design in accordance with the 1941 specifications of the A.A.S.H.O. have been given; and the effect of a recent type of bridge floor—the light-weight open steel type—is discussed.

Considerable new material on vertical-lift bridges has been added in Section 2. Recent good examples of vertical-lift spans are included in the way of both descriptive matter and illustrations.

Section 4 on Continuous Swing Bridges has been considerably augmented by new material and illustrations on recent examples of continuous bridges, including the Wichert truss.

New material illustrating and describing the San Francisco–Oakland Bay Bridge, East Bay Crossing, has been added to Section 5 on Cantilever Bridges.

Section 6 on Suspension Bridges is considerably enlarged by the material pertaining to the George Washington and Golden Gate Bridges. Comparisons between these two major structures of the suspension type are made, covering such matters as the erection of the towers, erection of the footbridges, spinning of the cables, and erection of trusses and floor systems. Features of the world's largest suspension bridges are also given, with numerous recent illustrations.

Steel Arch Bridges, Section 7, contains new material pertaining to good examples of recent steel arches.

Credit has been given in the text of the volume for all data, illustrations, or specifications used for the purpose of supplementing the technical matter. Mention is made here of the participation of the following

Associate Editors in the preparation of the First Edition: Chas. A. Ellis, Phil A. Franklin, Arthur G. Hayden, C. B. McCullough, H. E. Pulver, and D. B. Steinman.

The senior author of this revision, who prepared the Preface to the Second Edition, acknowledges the continued and very helpful collaboration of his associate, Mr. H. E. Langley, and thanks all others who have in any way contributed to the preparation of this, the Second Edition.

R. R. ZIPPRODT.

BETHESDA, MARYLAND,
September, 1943.

PREFACE TO THE FIRST EDITION

This volume is one of a series designed to provide the engineer and the student with a reference work covering thoroughly the design and construction of the principal kinds and types of modern civil engineering structures. An effort has been made to give such a complete treatment of the elementary theory that the books may also be used for home study.

The titles of the six volumes comprising this series are as follows:

Foundations, Abutments and Footings
Structural Members and Connections
Stresses in Framed Structures
Steel and Timber Structures
Reinforced Concrete and Masonry Structures
Movable and Long-span Steel Bridges

Each volume is a unit in itself, as references are not made from one volume to another by section and article numbers. This arrangement allows the use of any one of the volumes as a text in schools and colleges without the use of any of the other volumes.

Data and details have been collected from many sources and credit is given in the body of the books for all material so obtained. A few chapters, however, throughout the six volumes have been taken without special mention, and with but few changes, from Hool and Johnson's Handbook of Building Construction.

The Editors-in-Chief wish to express their appreciation of the spirit of cooperation shown by the Associate Editors and the Publishers. This spirit of cooperation has made the task of the Editors-in-Chief one of pleasure and satisfaction.

G. A. H.
W. S. K.

MADISON, WIS.,
September, 1923.

CONTENTS

PREFACE TO THE SECOND EDITION.....	v
PREFACE TO THE FIRST EDITION.....	vii

Section 1. Bascule Bridges

ART.	DESIGNS AND TYPES OF BASCULE BRIDGES	PAGE	ART.	BASCULE SUPERSTRUCTURE DESIGN AND ERECTION PROBLEMS	PAGE
1.	Early types.....	1	13.	Balance requirements.....	39
2.	Advantages inherent in the bascule type.....	1	14.	Live-load stresses.....	43
	<i>a.</i> Rapidity of operation.....	1	15.	Dead-load stresses.....	46
	<i>b.</i> Interference with channel during operation.....	2	16.	Wind-load stresses.....	47
	<i>c.</i> Duration of opening.....	2	17.	Floor design.....	48
	<i>d.</i> Pier considerations.....	2	18.	Erection features to be considered in the design.....	49
	<i>e.</i> Adaptability to wide roadways.....	3	19.	Counterweights.....	51
	<i>f.</i> Safety to land traffic.....	4	20.	Design specifications peculiar to bascules.....	57
	<i>g.</i> Effect of collisions with river craft.....	5		FOUNDATIONS FOR BASCULE SPANS	
	<i>h.</i> Bascule <i>vs.</i> vertical lift.....	5	21.	Conditions peculiar to bascule spans.....	58
3.	Relative economy of the bascule type.....	5	22.	General description of a typical bascule pier.....	63
4.	Cable-lift bascules.....	8	23.	Counterweight pits.....	64
	<i>a.</i> Spiral counterweight drums.....	10	24.	Anchor columns.....	65
	<i>b.</i> Sectional counterweights.....	13	25.	Tremic seal.....	66
	<i>c.</i> Curved track, and rolling counterweight.....	13	26.	Operator's houses.....	69
5.	Roller-lift bascules.....	15	27.	Pier fenders.....	71
6.	Trunnion-type bascules.....	19		COMPLETE STRUCTURAL DESIGN OF A DOUBLE-LEAF SIMPLE-TRUNNION DECK BASCULE HIGHWAY BRIDGE	
	<i>a.</i> Simple trunnion or "Chicago" type.....	20	28.	Data.....	73
	<i>b.</i> Strauss type.....	24	<i>a.</i>	General description.....	73
7.	Semi-lift bascule spans.....	25	<i>b.</i>	Governing dimensions.....	75
8.	Other types of bascule spans.....	27	<i>c.</i>	Loads.....	75
	SELECTION OF TYPE OF BASCULE BRIDGES		<i>d.</i>	Permissible stresses.....	76
9.	Single <i>vs.</i> double leaf.....	29	<i>e.</i>	Counterweights.....	78
10.	Through <i>vs.</i> deck spans.....	33	<i>f.</i>	Anchor-arm lateral system..	78
11.	Arrangement of piers.....	37	<i>g.</i>	Buffer blocks.....	78
12.	Relative merits of different types	38			

ART.	PAGE	ART.	PAGE
29. Design of floor system.....	79	38. Maximum starting force at the rack circle.....	126
a. Flooring.....	79	a. Inertia of the moving mass..	126
b. Stringers and floor beams...	79	b. Wind resistance.....	127
c. Horizontal girder.....	81	c. Frictional resistance.....	127
30. Design of main truss members..	81	d. Total tangential force at rack circle.....	128
a. Preliminary calculation of dead loads.....	83	39. Design of rack and main drive pinion.....	128
b. Determination of dead-load stresses in counterweight arm.....	86	40. Machinery layout.....	133
c. Live-load stress diagrams...	88	41. Design of gearing.....	135
d. Shear lock stresses.....	89	42. Design of shafting.....	140
e. Dead-load stresses—leaf open	91	43. Keys for shaft S1.....	143
f. Wind-load stresses.....	92	44. Hand operating mechanism...	143
g. Impact stresses.....	92	45. Center lock mechanism.....	144
31. Design of lateral system.....	93	46. Motor power required for center lock.....	145
32. Miscellaneous parts of the moving leaf.....	98	47. Design of center lock shafting..	149
33. Fixed part.....	99	48. Design of pin (P1) in crank....	149
a. Floor slab.....	99	49. Design of gearing for center lock drive.....	150
b. Stringers.....	100	50. Calculation for bearings for main pinion shaft... ..	152
c. Columns on main girder.....	100	51. Design for main trunnions.	152
d. Main trunnion girder.....	101	52. Design of hand brakes.....	154
e. Grillage brace.....	103	53. Permissible unit stresses.....	157
34. Counterweight calculations and methods of balancing span 104		a. Permissible unit stress in concrete.....	157a
		b. Permissible unit stresses in reinforcing steel.....	157a
		c. Permissible unit stresses in structural steel.....	157a
		54. Effect of light floors.....	157b

DESIGN OF OPERATING MACHINERY

Section 2. Vertical-lift Bridges

1. Advantages of vertical-lift bridges.....	158	types of vertical-lift bridges	161
2. Classification of vertical-lift bridges.....	160	4. Description of a few vertical-lift bridges.....	163
3. Adaptability of the different		5. General design notes.....	172
		6. Recent vertical lift spans.....	179

Section 3. Swing Bridges

CENTER-BEARING SWING BRIDGES

1. General considerations.....	180	5. Positive moment about U_s . Case III.....	186
2. Conditions of loading.....	180	6. Negative shear in panel 0-1. Case IV.....	187
3. Stresses in a swing span.....	182	7. Shear in panel 1-2.....	188
4. Positive shear in panel 0-1. Case III.....	184	8. Shear in panel 2-3.....	189

CONTENTS

ART.	PAGE	ART.	PAGE
9. Shear in panel 3-4.....	189	18. Moment about L_6	194
10. Shear in panel 4-5.....	190	19. Dead load, bridge open. Case I	194
11. Shear in panel 5-6.....	190	20. Dead load, ends raised. Case II	194
12. Moment about L_2	191	21. Combinations.....	194
13. Moment about L_4	191	22. Reactions from Williot diagram.	194
14. Moment about U_6	192		
15. Moment about L_6	192	RIM-BEARING SWING BRIDGES	
16. Case V, both arms loaded. Broken loads.....	192	23. General considerations.....	196
17. Negative shear in panel 5-6....	193	24. Partial continuity. Equal moments at center supports	197

Section 4. Continuous Bridges

DESIGN AND ERECTION OF CONTINUOUS BRIDGES	spans..... 225
1. Advantages of continuous bridges.....	199
2. Economic comparisons with simple spans.....	199
3. Economy of the continuous type	200
4. Prejudices against the continuous type.....	200
5. Conditions favorable for the continuous type.....	201
6. Economic proportions and number of spans.....	201
7. History of continuous bridges..	202
8. The Sciotoville Bridge.....	202
9. Erection of the Sciotoville bridge	208
10. The Allegheny River continuous bridge.....	211
11. Erection of the Allegheny River bridge.....	214
12. The Nelson River continuous bridge.....	214
13. Erection of the Nelson River bridge.....	217
14. The C. N. O. bridge at Cincinnati.....	217
STRESSES IN CONTINUOUS BRIDGES	
15. The elastic curve.....	218
16. Elastic curves for constant I..	218
17. Influence diagram for bending moments.....	220
18. Influence diagram for shears...	222
19. Two equal spans with symmetrical loading.....	223
20. Two unequal spans.....	223
21. Reactions for two continuous spans.....	225
22. Moments and shears for two unequal spans.....	225
23. Elastic curve for variable I....	226
24. Special case—Triangular variation of I.....	227
25. Elastic curve for a continuous truss.....	230
26. Example—Application of method to Sciotoville bridge.....	232
27. Comparison of elastic curves for different assumptions....	234
28. Influence diagrams for continuous trusses.....	236
29. Determination of live-load stresses.....	236
30. Determination of dead-load stresses.....	237
31. Bridges continuous over three spans.....	237
32. Elastic curves for three-span continuous bridge.....	237
33. Symmetrical three-span continuous girders.....	241
34. Influence diagrams for three-span continuous bridge...	244
35. The method of double influence lines.....	246
36. Continuous bridge of three equal spans.....	249
37. Multiple-span continuous girders	249
38. Fixed points in continuous spans	250
39. General rules for loading placement.....	252
40. Effect of settlement of supports	253
41. Example—Effect of settlement in Sciotoville bridge.....	255

ART.	PAGE	ART.	PAGE
42. Continuous bridges 1923-1942	255	46. Ludlow ferry bridge over Potomac River	255 <i>d</i>
43. The C. & O. railroad bridge, Cincinnati, Ohio	255 <i>a</i>	47. Hancock bridge over Potomac River	255 <i>e</i>
44. Lake Champlain bridge	255 <i>b</i>	48. Licking Creek bridge, Maryland, and Sagamore Creek bridge, New Hampshire	255 <i>e</i>
45. Sagamore bridge over Cape Cod Canal, Mass.	255 <i>c</i>		

Section 5. Cantilever Bridges

1. Cantilever bridges compared with continuous bridges	256	8. Erection of cantilever bridges	270
2. The cantilever bridge as a development of the continuous bridge	256	9. Special details	270
3. Statically determinate and statically indeterminate cantilever bridges	257	<i>a.</i> Erection adjustments	270
4. Conditions of statical determination	257	<i>b.</i> Anchorages	275
5. Examples of cantilever bridges	261	<i>c.</i> Lateral systems	279
6. Computation for moments and shears	262	<i>d.</i> Stringer expansion bearings	280
7. Reactions for an indeterminate cantilever bridge	269	10. Economy	281
		11. Relative rigidity	283
		12. Economical ratios of span lengths	283
		13. Miscellaneous data	284
		14. Arched cantilever bridges	285
		15. Some esthetic considerations	288
		16. San Francisco-Oakland Bay Bridge, East Bay crossing	288 <i>a</i>

Section 6. Suspension Bridges

STRESSES IN SUSPENSION BRIDGES

1. The cable	289	truss	303
<i>a.</i> Form of the cable for any loading	289	<i>c.</i> Shears in the stiffening truss	304
<i>b.</i> The parabolic cable	290	5. Two-hinged stiffening trusses	306
<i>c.</i> Unsymmetrical spans	291	<i>a.</i> Determination of the horizontal tension H	306
<i>d.</i> The catenary	293	<i>b.</i> Moments in the stiffening truss	310
<i>e.</i> Deformations of the cable	294	<i>c.</i> Shears in the stiffening truss	311
2. Unstiffened suspension bridges	294	<i>d.</i> Temperature stresses	313
<i>a.</i> Stresses in the cables and towers	295	<i>e.</i> Deflections in the stiffening truss	313
<i>b.</i> Deformations under central loading	295	<i>f.</i> Straight backstays	314
<i>c.</i> Deformations under unsymmetrical loading	296	6. Hingeless stiffening trusses	315
<i>d.</i> Deflections due to elongation of cable	296	<i>a.</i> Fundamental relations	315
3. Stiffened suspension bridges	297	<i>b.</i> Moments at the tower	316
<i>a.</i> Assumptions used	298	<i>c.</i> The horizontal tension H	317
<i>b.</i> Fundamental relations	299	<i>d.</i> Moments in the stiffening truss	318
<i>c.</i> Influence lines	301	<i>e.</i> Temperature stresses	319
4. Three-hinged stiffening trusses	302	<i>f.</i> Straight backstays	320
<i>a.</i> Analysis	302	7. Braced-chain suspension bridges	321
<i>b.</i> Moments in the stiffening		<i>a.</i> Three-hinged type	321
		<i>b.</i> Two-hinged type	322
		<i>c.</i> Hingeless type	323

ART.	PAGE	ART.	PAGE
DESIGN OF SUSPENSION BRIDGES—			
CONSTRUCTION FEATURES			
8. Types of suspension bridges.....	324	28. Wind stresses in tower.....	345
9. Economic proportions.....	326	29. Calculation of cable wire.....	346
10. Chain construction.....	327	30. Calculation of cable diameter... 346	
11. Parallel-wire cables.....	328	31. Calculation of wrapping wire... 347	
12. Twisted-wire ropes.....	330	32. Estimate of rope strand cables. 347	
13. Towers.....	332	ERECTION OF SUSPENSION BRIDGES	
14. Saddles.....	332	33. Erection of the towers.....	347
15. Anchorages.....	333	34. Stringing the footbridge cables. 349	
DESIGN CALCULATIONS FOR TWO-HINGED			
SUSPENSION BRIDGE WITH SUSPENDED			
SIDE SPANS			
16. Dimensions.....	335	35. Erection of footbridges.....	349
17. Stresses in cable.....	335	36. Initial erection adjustments... 350	
18. Moments in stiffening truss—		37. Spinning of cables.....	352
main span.....	336	38. Erection of trusses and floor	
19. Bending moments in side spans 338		system.....	353
20. Shears in stiffening truss—main		39. Final erection adjustments.... 354	
span.....	338	40. Cable wrapping.....	355
21. Shears in side spans.....	340	41. Erection of wire-rope cables... 356	
22. Temperature stresses.....	341	42. Erection of eyebar chain bridges 357	
23. Wind stresses in bottom chords 342		43. Time required for erection.... 357	
24. Design of tower.....	343	44. Suspension bridges, 1923–1943. 358	
25. Movement of top of tower.... 343		45. Erection of towers.....	358
26. Forces acting on tower.....	344	46. Stringing footbridge cables... 358 <i>b</i>	
27. Calculation of stresses in tower. 345		47. Erection of footbridges..... 358 <i>b</i>	
		48. Initial erection adjustments... 358 <i>d</i>	
		49. Spinning of cables.....	358 <i>d</i>
		50. Erection of trusses and floor	
		system.....	358 <i>j</i>
		51. Some features of the world's	
		largest suspension bridges 358 <i>j</i>	

Section 7. Steel Arch Bridges—General

1. Classification and types of steel arch bridges.....	359	4. Erection of arch bridges.....	364
2. Relative merits of various types of arch construction.... 362		5. General design features.....	368
<i>a.</i> Fixed or hingeless type..... 362		<i>a.</i> Shape of arch.....	368
<i>b.</i> Single-hinge type.....	362	<i>b.</i> Temperature stresses.....	371
<i>c.</i> Two-hinged type.....	362	<i>c.</i> Location of crown hinge.... 372	
<i>d.</i> Three-hinged type.....	362	<i>d.</i> Tied arches.....	373
<i>e.</i> Various types in general... 363		6. The Rainbow Bridge, Niagara Falls.....	374 <i>a</i>
3. Loadings on arch bridges.....	363	7. Chesterfield and Orford Bridges 374 <i>a</i>	

Section 8. Analysis of Three-hinged Arch Bridges

1. Equilibrium polygons.....	375	arches.....	381
2. Algebraic calculation of reactions.....	378	5. Fiber stresses in solid ribbed arch spans.....	385
3. Stresses due to moving loads (method of reaction lines). 378		6. Graphical analysis of stresses.. 388	
4. Influence lines for three-hinged arch spans.....	388	7. Wind stresses in spandrel-braced arch spans.....	388

Section 9. Analysis of Fixed Arches

ART.	PAGE	ART.	PAGE
FUNDAMENTAL THEOREMS RELATING TO INTERNAL WORK IN RIBS AND FRAMES		formulas.....	420
1. The laws of internal work in structural frames.....	393	11. Horizontal and inclined loads..	426
2. Deflections and panel point displacements in frames....	396	12. Direction of the redundant forces.....	426
3. Work expressions for solid-web beams and cantilevers....	400	THE ANALYSIS OF FIXED FRAMED ARCHES (SYMMETRICAL AND UNSYMMETRICAL SPANS)	
a. Derivation of expressions for internal work in ribs and beams.....	404	13. Unsymmetrical spans.....	429
4. Displacements and deflections in beams and ribs.....	406	14. Symmetrical spans.....	439
DEVELOPMENT OF THE GENERAL ELASTIC EQUATIONS FOR ARCH FRAMES OR TRUSSES		DEVELOPMENT OF GENERAL ELASTIC EQUATIONS FOR RIB ARCHES	
5. Redundant forces in a fixed framed arch.....	408	15. Development of formulas.....	440
6. Residual frames.....	409	DEVELOPMENT OF ELASTIC INFLUENCE LINES FOR RIB ARCHES	
7. Properties of the residual frame	410	16. Development of formulas.....	446
8. Development of the general elastic equations.....	412	17. Graphical solution for redundant influence diagrams..	449
ELASTIC INFLUENCE LINES FOR FIXED FRAMED ARCHES		18. Stresses due to uniform temperature changes.....	450
9. Simplification of elastic equations.....	414	19. Stresses due to a variable temperature change.....	452
10. Application of above simplified		20. Stresses due to rib shortening or axial thrust.....	453
		21. Symmetrical arch ribs.....	454
		COMPLETE ANALYSIS OF A 350-FT. FIXED STEEL ARCH RIB	

Section 10. Analysis of Two-hinged Arches

INDEX.....	489
------------	-----

MOVABLE AND LONG-SPAN STEEL BRIDGES

SECTION 1

BASCULE BRIDGES

DESIGNS AND TYPES OF BASCULE BRIDGES

1. Early Types.—The earliest type of bascule construction doubtless consisted of a simple span, trunnioned or hinged at one end, moving in a vertical plane about such trunnion, by virtue of an out-haul line attached to the free end and running upward and inward to the source of power. The genealogy of this type may be traced back to an origin in the medieval drawbridge used to carry traffic over artificial military waterways. These types and the earlier modern types were not counterweighted to any extent and their field of utility was, therefore, quite restricted.

A few bascule bridges were constructed in Europe during the first half of the nineteenth century, but no very great attempt was made to develop the art. The real beginning of development for the modern bascule bridge may be said to date back about 50 years.

The Van Buren Street Bridge in the city of Chicago, a Scherzer rolling bascule, plans for which were completed in 1893, and the famous tower bridge in London, a roller bearing, trunnion bascule constructed about the same time may be regarded as the fore-runners of the modern bascule span.

2. Advantages Inherent in the Bascule Type.—The development of the bascule bridge has been rapid because of its many advantages, among which may be mentioned the following:

2a. Rapidity of Operation.—The bascule may be raised slightly to permit the passage of numerous small boats which fail to clear the closed span by a small margin, the time for such operation being of course proportionally less than full opening time. The swing span, on the other hand, requires a full 90-deg. opening for each vessel regardless of vertical clearance. The degree to which this difference in method of

operation may influence the selection, or dictate the relative economy depends of course on traffic conditions. For high-masted schooner traffic on the waterway, and for high grade-line locations the disadvantage of the swing type is not so apparent. Where there is a large traffic in small boats, on the other hand, the necessary frequent complete swing openings may simply put the swing span out of the competition regardless of cost consideration. Especially is this true where the clearance line for the bridge must lie close to the water surface.

2b. Interference with Channel during Operation.—The swing span blocks the channel during operation and, in localities where docking facilities must be maintained close to the sides of the bridge, it oftentimes becomes impossible to obtain the requisite room for the horizontal swing. This is more often the case in narrow waterways where the movable span constitutes practically all of the stream crossing.

2c. Duration of Opening.—For the bascule type, river traffic will approach within a comparatively short distance of the bridge structure, while, for the swing span, craft must stand off much farther on account of the greater difficulty in negotiating the channel and swinging around the draw rest. For congested river traffic the difference in time resulting from the above operation factor is truly surprising. Concerning this feature, F. A. Rapp, Bridge Engineer for the City of Seattle, makes the following comment:

It seems to me that the time consumed in the actual opening and closing of the bridge is of secondary importance. The average time consumed in opening and closing the motor-operated bridges of the city at Salmon Bay and the West Waterway at Spokane Street is about 12 min. The actual time of making the swing is less than a minute so that the actual time of moving is a relatively small amount of the time the bridge is out of commission. The fact is, that the vessel signals for the draw while some distance away and while moving at a speed slow enough to negotiate the passage of the bridge without accident. The time consumed in holding the bridge open therefore while the boat passes through is the big item.

Whatever we can do to diminish the time the bridge is held open will be most effective in reducing the delay to road traffic. I have waited at the city waterway bridge in Tacoma for 35 min. while a Standard Oil tank vessel was passing the draw. The operator could have opened and closed the bridge a half-dozen times but was forced to open when signalled and keep open until the vessel had cleared. Of course, this is a rare occasion but serves to illustrate the point.

In my opinion a wide clear channel between masonry piers will inspire confidence in the navigator and so induce him to go through at increased speed.

I believe that as between a bascule or vertical lift and a swing bridge, for the same clear width of channel, the navigator will prefer the former types on account of their symmetrical position across the stream.

2d. Pier Considerations.—The swing span necessitates the use of a large pivot pier in the center of the stream. For certain locations the presence of this pivot pier operates to deflect the current toward the sides of the stream with consequent destructive erosive action at the

banks or quay walls. For such locations the swing span is eliminated from consideration at the outset.

The draw rest for the swing type constitutes another serious obstruction to the channel as well as an added menace to river traffic. The dictates of economy usually require such construction to be of timber, thus introducing an added maintenance cost. It is true that as against this portion of the structure there must be considered the matter of maintenance of the fenders on the bascule piers. However, in nearly every case the first cost and maintenance charge on the latter is much less than in the case of the swing span draw rest. Moreover, in many cases vessels are compelled to deviate from their natural course in order to pass around the pivot pier and draw rest. The openings being narrow and the movement of these craft naturally slow, this condition operates to greatly lengthen the time during which the span must remain open.

2e. Adaptability to Wide Roadways.—Considerations of stability limit the width which the swing span may overhang the pivot

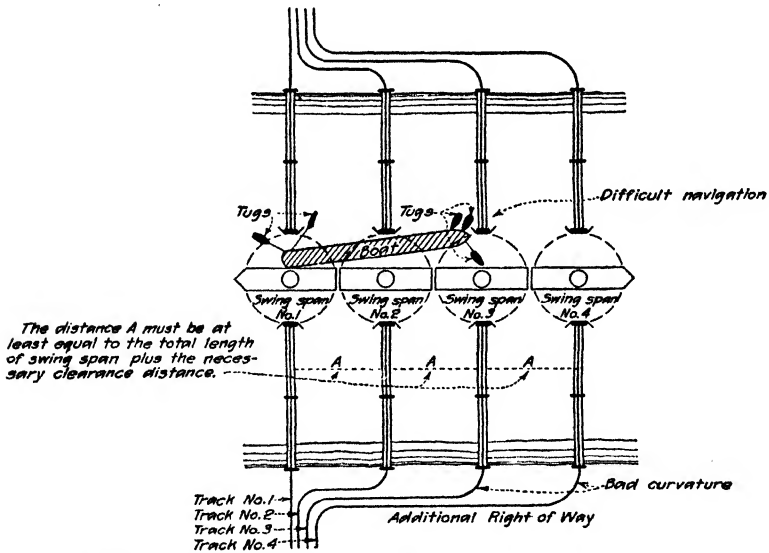

FIG. 1.—Four single track swing spans constructed from time to time to carry additional rail-road trackage.

pier when open. This fact puts a fixed relationship between the width of the roadway and the dimensions of the pivot pier. For wide roadways, therefore, it is neither economical nor feasible from the standpoint of channel obstruction to build a pivot pier of the dimensions necessary to properly carry the span.

Many single track railway swing bridges have become obsolete long before they were worn out, owing to the tremendous growth of traffic,

particularly in cities and terminals. The addition of a second track necessitates the removal of the existing bridge. If a double track bridge is constructed to replace the above, increased traffic requiring a third track installation will require the discarding of this bridge also, and so on.

Unless this method of procedure is adopted, individual spans as shown in Fig. 1 must be built because of the horizontal swing room required for the draw span. This method results in objectionable curved tracks widely spread, extra right of way, the necessity for additional bridge operators, an obstructed and difficult channel, retarded railroad traffic, and an increased hazard to all parties concerned.

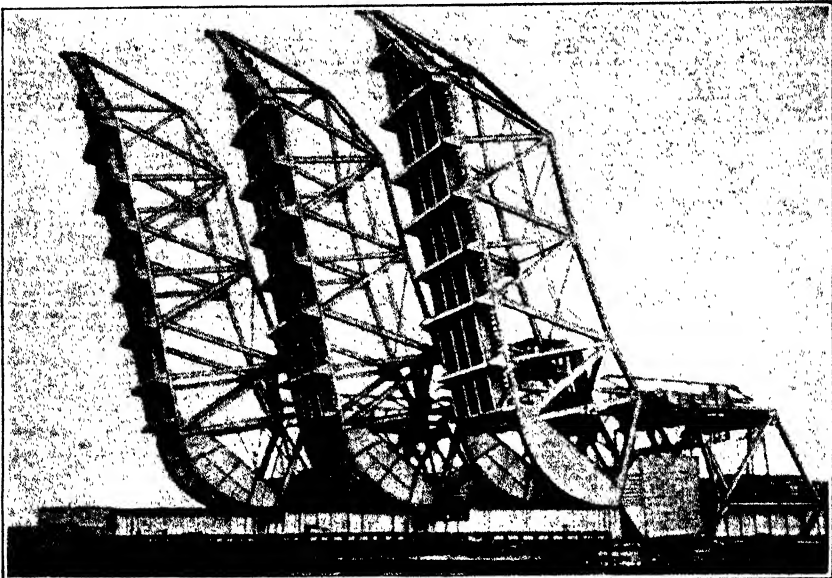

(Courtesy of the Scherzer Rolling Lift Bridge Co.)

FIG. 2.—Six track rolling bascule bridge.

Bascule spans may be arranged in the manner shown above to operate singly, in pairs, or as a unit as desired. Any number of spans may be added as traffic demands increase. This fact alone constitutes a big advantage over the swing span which must be arranged as shown in Fig. 1 if additional trackage is desired.

Contrasting this with the condition shown in Fig. 2, wherein six tracks are carried over three independently operated bascule spans, the advantage of the latter type is at once apparent. These spans may be arranged to operate singly, in pairs, or in a group as desired and any number of tracks may be provided by adding other spans.

2f. Safety to Land Traffic.—Railway traffic over any movable bridge is generally protected by means of automatic, interlocked derailing switches, block signals, etc. For highway traffic, on the other hand, the only protection afforded is that of the roadway gates. Most types of double leaf bascules may be so arranged that the open leaf acts

as an effectual barricade augmenting the roadway gates in this regard. Where such types may be employed, the barrier afforded by the raised leaves constitutes a very great advantage over the swing span. One of the greatest problems confronting engineers today is the safeguarding of highway traffic and in this regard the swing span cannot compete with the double leaf bascule.

2*g*. Effect of Collisions with River Craft.—Not enough data are at hand to warrant a general conclusion, but it seems to be generally conceded that river traffic may do considerably more damage through a collision with the open end of a swing span, thus crumpling up the span and draw rest, than would be possible in the case of a bascule.

2*h*. Bascule vs. Vertical Lift.—The advantages of the bascule type over the ordinary swing span, as enumerated above, also apply with respect to the vertical lift type, the choice between the bascule and vertical lift being largely a matter of esthetics and economics—of first cost, maintenance, and operation.

It would seem that as regards the matter of protection to traffic the double leaf bascule, in certain of its types, possesses a distinct point of superiority over the vertical lift type. By locating the break in the roadway floor ahead of a vertical plane passed through the axis of the trunnion, the leaf of the deck trunnion bascule for example, forms a traffic barrier from the instant that it begins to lift.

This barrier is continuous during the entire operation of opening and closing and until the bridge is again fully closed and seated. A traffic barrier of this kind in connection with a vertical lift span could only operate at the latter end of the lift and in the event of the span being lifted to less than its full height (which would constitute the case in the majority of openings) such traffic barrier would not be effective.

The relative economy of the bascule as compared with the vertical lift is a question involving many conditions and one which warrants individual study. In general the vertical lift shows to maximum advantage for long spans and low lifts, that is, in localities where only a limited vertical clearance is required.

3. Relative Economy of the Bascule Type.—The relative economy in first cost of the bascule type as against the swing span is a matter involving many factors and a problem which must be determined in each individual case (assuming that traffic and other conditions as outlined in Art. 2 have not already eliminated the swing type from consideration). The comparative study outlined below was made in the writer's office during the summer of 1920 and may prove illuminating in so far as general principles are concerned.

Type A, in the table, is an ordinary rim bearing swing span (highway loadings) providing a clear channel, on either side of the pivot pier, of 100 ft.

Type B is an alternate design for a single leaf bascule span. This design affords the same clear waterway and is used in combination with a 100-ft. fixed pony truss span.

COMPARATIVE ESTIMATES OF SUPERSTRUCTURE ONLY

Item	Type A, swing span			Type B, bascule		
	Quantity	Rate	Amount	Quantity	Rate	Amount
Structural steel.....	309,000 lb.	10c.	\$30,900.00	291,000 lb.	10c.	\$29,100.00
Machinery.....	34,700 lb.	35c.	12,145.00	33,500 lb.	35c.	11,725.00
Floor and handrail.....	(Lump sum)	...	2,050.00	2,000.00
Draw rest.....	(Lump sum)	...	1,850.00
Concrete.....	(Counterweight)	145 cu. yd.	\$20	2,900.00
Reinforcing steel.....	(Counterweight)	3,000 lb.	7c.	210.00
Fender piling.....	600.00
Operator's house.....	(Lump sum)	...	1,500.00	1,500.00
Gasoline power plant.....	2,500.00	2,500.00
Total.....	50,945.00	50,535.00
Royalty charge.....	(5 per cent assumed)	2,526.75
Grand total.....	50,945.00	53,061.75

A cost comparison based on 1920 unit prices is given in the table concerning which the following may be said:

The difference in cost for the structural steel portion is in favor of the bascule type. (This result is to be expected in view of the fact that both leaves of the swing span act as cantilevers under dead load while in the bascule type there is but one such span.) The swing span is longer than the combined bascule and fixed span of Type B but this fact is to a certain extent offset by the metal required for counterweight frames and arms. On the other hand, the cost of the bascule counterweight more than offsets the cost of the draw rest for Type A.

All things considered the superstructure cost appears slightly less for the swing span.

Had it been possible to eliminate the fixed span and run trestle construction up to the bascule pier, Type B would have shown economy over the swing span.

As between the various commercial types of bascule bridges it may be said in general that each has its peculiar advantages, and will doubtless show economy either in first cost or cost of operation under certain conditions. The subject of comparison between types is too lengthy and involved for treatment at this point.

The following quoted from Samuel Murray, Chief Engineer of the Oregon-Washington Railroad and Navigation Company is of interest as throwing further light on this subject. It will be observed that Mr. Murray's conclusions are not in perfect agreement with those stated

above, owing perhaps to the fact that his results are deduced from a consideration of railway bridges, while the above comparison is based on highway loadings. It is also observed that Mr. Murray's comparisons are based on a slightly larger opening for the bascule span than for the swing type which is giving the swing span a distinct advantage.

Where average conditions obtain, that is, where traffic is moderate, fairly high masts must be provided for, openings of 100 ft. or more are required, foundations are ordinary and no obstructions exist to interfere with swinging—the swing span is the cheapest structure that can be built and its reliability has been proven by the numberless examples in service.

A bascule suitable for a 180-ft. opening has an overall dimension of about 220 ft. on centers, and will require about 640 tons of steel for E-55 loading. A swing span 335 ft. long and suitable for two 150-ft. openings will require 630 tons under the same specifications. Both have three piers; and if we consider the concrete counterweight of the bascule, it will more than make up the difference due to the large pivot pier. The royalty of the patentee may be balanced against the cost of the draw-pier protection. The swing span is longer than the bascule, however, and we must make up this length with another pier and a 115-ft. span. The cost of these will be about the difference between the bascule and the swing span. This is a rough comparison, but it is confirmed by experience with many similar cases.

Where double-tracking is necessary, or wide roadways required, where the area used in swinging is needed for other purposes and the center pier protection interferes too greatly with river traffic to allow its use, the bascule or vertical lift should be used.

Bascule bridges can be built for most lengths of span that are necessary, and we hesitate to place a limit on their possible length; however, for single leaves, it is less than that of the vertical lift.

The trunnion bridge is cheaper than the vertical lift for locations where tall masted traffic must be provided for, easier to erect under traffic and less affected by settlement, and maintenance on cables is likely to be a large item.

For low lifts of any length the vertical lift is the cheaper structure of the two, and has a special advantage for short spans over canals and other narrow waterways, and for longer spans where the adjacent spans are through structures.

In congested locations, the time of opening becomes important. The swing span usually requires from 1 to 2 min. to open it and the same time to close it and it must often remain stationary until the boat has gotten out of the swinging circle so that it is conservative to say that a delay of at least 5 min. will ensue.

The bascules and vertical lifts require from $\frac{3}{4}$ to 1 min. to open fully and they can close in the same time. Of the two the vertical lift is probably a little quicker for small traffic and slower for the full openings required for large vessels. It is the more likely to get out of commission and entirely stop traffic. It should be observed that small boats are largely in the majority and that, if plenty of head-room is provided, a bridge will have to be opened only for the larger vessels. It is often justifiable on this basis to choose a slightly higher level notwithstanding the additional cost and inconvenience of the approaches on a grade.

F. A. Rapp, Bridge Engineer for the City of Seattle, has the following to say in regard to movable bridges in general:

My opinion is that the most important item to be considered in any type of movable bridge is the maintenance cost. The interest on bonds will be a constantly decreasing charge whereas the cost of repairs is a constantly increasing one. If this is initially high, it can soon overcome any reasonable difference in the first cost.

Bearing on this point, I submit some figures for maintenance of movable bridges obtained from the Mayor of Chicago's annual reports.

TABLE OF COSTS OF REPAIRS OF ALL KINDS OF MOVABLE BRIDGES
Abstracts from the Annual Reports of the Mayor of Chicago
Rolling Lift

Year	Number of openings	Total repairs	Number of bridges	Average per bridge	Average per operation
1905	3,941	24,475	5	\$4,895.00	\$1.24
1906	3,512	35,049	8	4,381 00	1.24
1909	3,431	43,841	11	3,985.00	1.16
1910	3,547	40,971	13	3,151.00	0.89
1911	3,166	56,274	10	5,627.00	1.78

Trunnion Bascule

1905	1,190	8,582	5	1,716.00	1.44
1906	1,175	10,793	5	2,158 00	1.84
1909	1,925	8,937	7	1,277.00	0.66
1910	1,757	18,613	7	2,659 00	1.50
1911	1,940	22,195	9	2,466.00	1.27

Page Bascule

1905	1,577	3,737	1	3,737.00	2.37
1906	1,427	4,832	1	4,832.00	3.38
1909	2,880	5,987	1	5,897.00	2.04
1910	2,588	13,129	1	13,139 00	3.35
1911	1,903	6,352	1	6,352.00	3.34

Vertical Lift

1906	2,983	6,427	1	6,427.00	2.15
1909	3,468	7,122	1	7,122.00	2.06
1910	3,192	1,147	1	1,147.00	1.97
1911	2,919	5,769	1	5,769.00	1.98

Many other special instances may be cited and certain tentative rules and formulas may be worked out. In fact, certain curves and published data tending to indicate the relative first cost and operating economy for various types of movable spans are already available. The problem, however, is so highly involved and so extremely individual that such data is often misleading. For this reason the foregoing, which is merely typical and illustrative of the problem involved, is perhaps as far as this discussion should go.

4. Cable Lift Bascules.—The cable lift type, illustrated in Fig. 3, constitutes the earliest and most primitive of the bascules and has been

largely abandoned in favor of the more modern and costly types. For many localities, however—such, for example, as along sections of the Pacific Coast—this type still retains a field of usefulness, and will continue to be used for temporary structures and on secondary and lateral roads for many years to come. Local conditions which will render this type of merit may be enumerated as follows:

(1) The presence of a plentiful timber supply rendering timber construction very cheap.

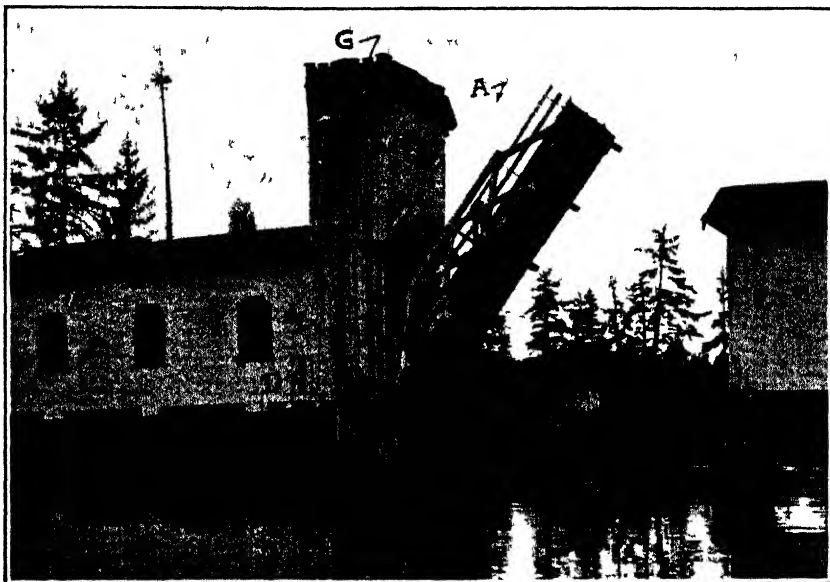

FIG. 3.—John Day River Bridge, Clatsop County, Oregon. Cable bascule span with sectional counterweight. (Span partly open.)

The span is lifted by means of the outhaul cable *A* which runs over the idler located in the tower *G* and thence down to the winding drum *D*. Keyed to this same shaft is the counterweight drum on which is wound the cable *B* running up over an idler at *G* and down to the sectional counterweights *C*. *E* is the guide frame for the sliding counterweights, *F* is the hinge or trunnion. Power is applied to the shaft, which carries the drums, at *D* by means of a capstan lever through the roadway floor to a worm and worm gear not visible in the photograph.

(2) An excessive haul for structural metal from the nearest railhead as contrasted with a close proximity of structural timber.

(3) The presence of numerous small streams, inlets and sloughs which have been declared navigable and which must be kept open for government snag boats and small fishing craft.

(4) The fact that the necessity for opening is very infrequent and that man power from the boat crew is always available when the spans need to be opened.

(5) The lack of adequate finances to meet the cost of more modern construction.

Figure 4 illustrates the general features of a cable lift bascule span such as has just been described.

At the beginning of the lift the torque of resistance is given by the term Wa and the stress in the outhaul cable is equal to $\frac{Wa}{c}$; at any other position—such, for example, as shown dotted—the resistance torque is Wa' and the outhaul cable stress $\frac{Wa'}{c'}$. It is thus seen that the cable stress is a constantly decreasing quantity and a simple arrangement of counterweights to keep the span in constant balance is the principal mechanical problem involved. It may seem at first thought that the constant balance is a needless refinement for the rough type of construction

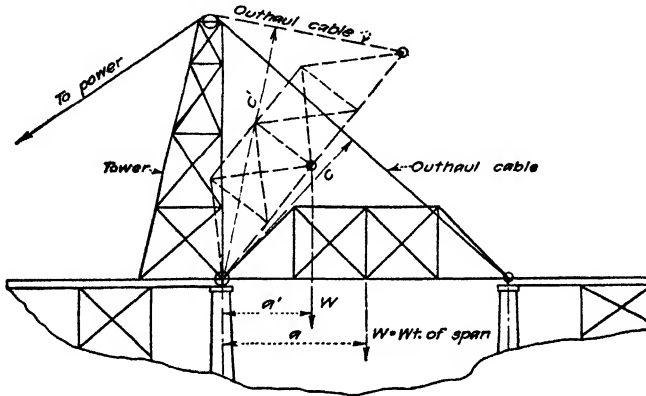

FIG. 4.

involved. Such, however, is not the case owing to the fact that man power must, in nearly every case, be employed and the crew from the small fishing boats is sometimes limited to two or three men. Moreover, these spans even though very short, are comparatively heavy and the lifting machinery receives scant attention, so that even after gearing down to the maximum permissible opening time (generally from 10 to 20 min.) the tangential force at the capstan bar or lever arm is relatively large. It seems, therefore, essential that the load be balanced so that only friction, inertia, and wind resistances need be overcome.

There are several methods used to effect this balance some of which may warrant a brief discussion.

4a. Spiral Counterweight Drums.—Figure 5 shows an arrangement sometimes used that originated, as far as is known, with Mr. Murray. This consists of one cylindrical and also one spiral drum, both keyed to the same shaft. The counterweight cable winds on the cylindrical drum while the counterweight unwinds from the spiral drum. The stress in the counterweight cable is thus seen to be $\frac{W'r_2}{r_1}$.

The stress in the outhaul cable at any point is equal to $\frac{Wa'}{c'}$ (see Fig. 4). The spiral drum may be so arranged that $\frac{Wa'}{c'} - \frac{W'r_2}{r_1} =$ a constant quantity, thus resulting in a uniform power line pull.

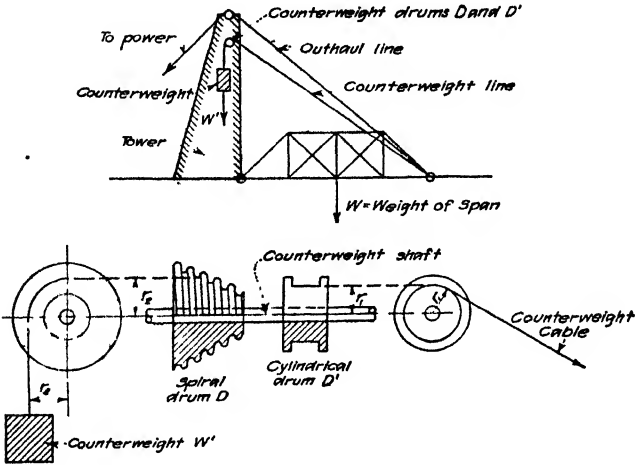

FIG. 5.

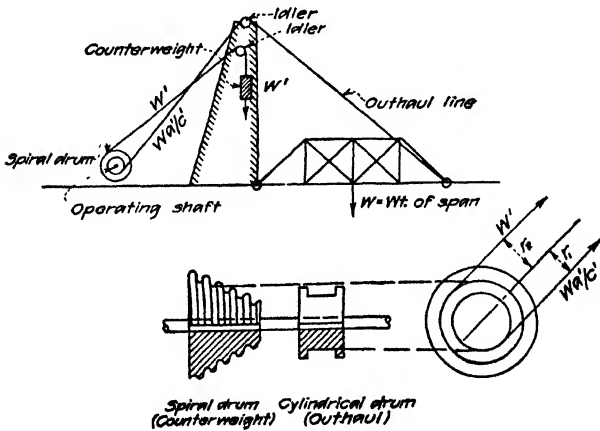

FIG. 6.

The objection to this arrangement lies in the fact that the term $\frac{W'r_2}{r_1}$ must never be made equal to $\frac{Wa'}{c'}$, for in that case the structure could not be lowered. In other words, this arrangement must always be under-counterweighted by enough to overcome static friction in order to operate in closing.

A better arrangement would be to run the outhaul cable over an idler and down to a cylindrical drum, keyed on to the operating shaft, as shown in Fig. 6. The spiral counterweight drum is keyed to this same shaft

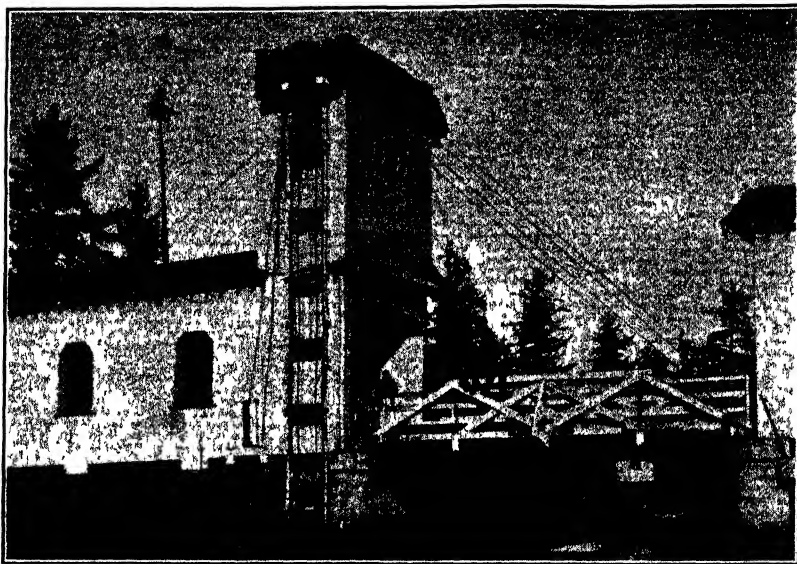

FIG. 7—John Day River Bridge, Clatsop County, Oregon. Cable bascule span with sectional counterweights (Span closed, see also Fig. 3.)

and runs up over another idler and down to the counterweight. By regulating the taper of the spiral drum so that $[W'r_2 - (\frac{Wa'}{c'})r_1] = 0$ at every point, a theoretical balance in every position would obtain.

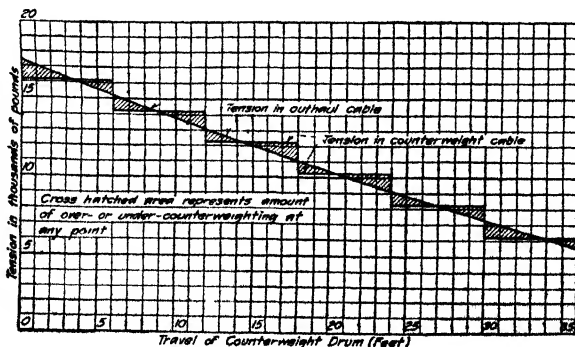

FIG. 8.

This latter arrangement also precludes the possibility of the span slamming shut as would be probable for the type shown in Fig. 5, inasmuch

as this type, being undercounterweighted, must be lowered by means of a band brake.

4b. Sectional Counterweights.—Figures 3 and 7 illustrate a movable span of this type. As the span rises, the outhaul cable tension, $\frac{Wa'}{c'}$, decreases and the counterweights seat one by one decreasing the stress in the counterweight cable proportionally. The outhaul cable *A* runs over a fixed sheave in the top of the tower *G* and thence down to the operating shaft. The counterweight cable drum is keyed on to this same shaft *D* and the counterweight cable *B* runs up over another sheave in the top of the tower and down to the counterweights *C* which slide in fixed leads *E* bolted to the sides of the bridge (see Fig. 3).

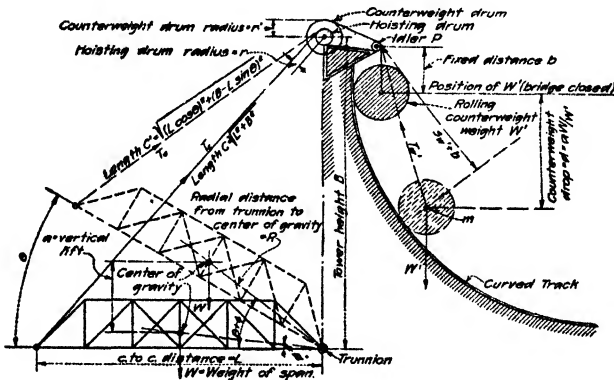

FIG. 9.

Figure 8 shows the relationship existing between the stresses in the outhaul and counterweight lines at various points of opening. The span is alternately over- and underbalanced during its travel and this fact constitutes the main objection to this method of operation. It is really surprising how apparent are these changes in balance to the man at the end of the capstan bar.

4c. Curved Track and Rolling Counterweight.—A diagrammatic sketch of a span of this type is shown in Fig. 9.

The contour of the curved track may be determined from the following considerations and formulas.

(a) Since for balanced action the work expended in raising the leaf must equal the energy released by the falling counterweight, we have

$$Wa = W'd$$

(b) If T_o represents the tension in the outhaul cable and T_w' represents the tension in the counterweight cable, and if δs_o and $\delta s_w'$ represent

respectively the infinitely small movements of these two cables, then at any instant

$$\frac{1}{2}T_c(\delta s_c) = \frac{1}{2}T_w'(\delta s_w')$$

or

$$\delta s_w' = \delta s_c \left[\frac{T_c}{T_w'} \right]$$

If the outhaul cable winds up on a drum of radius r and the counterweight cable unwinds on a drum of radius r' keyed to the same shaft, then for equilibrium

$$T_c r = T_w' r'$$

$$\frac{T_c}{T_w'} = \frac{r'}{r} \quad (\text{a constant} = K)$$

Then

$$\delta s_w' = \delta s_c (K)$$

or, integrating

$$s_w' = s_c (K)$$

For the fully closed position of the leaf, the length of the outhaul cable is given by the formula

$$C = \sqrt{L^2 + B^2}$$

For any angular opening of θ degrees

$$C' = \sqrt{(L \cos \theta)^2 + (B - L \sin \theta)^2}$$

Whence for the angular opening θ

$$s_c = C - C'$$

$$s_w' = K s_c$$

$$a = R (\sin (\theta + \phi) - \sin \phi). \quad (\text{see Fig. 9})$$

$$d = a \left(\frac{W}{W'} \right)$$

To plot the contour of the curved path taken by the counterweight therefore, proceed as follows:

About the idler pulley P swing an arc of radius $(s_w' + b)$ (see Fig. 9). This arc will intersect a horizontal line whose vertical distance below the center of the counterweight at the "closed" point is equal to d , in a certain point m . In this manner any number of points may be located and the curve, taken by the center of the moving counterweight, sketched in.

The disadvantage of this type lies in the excessive amount of material required to construct the curved track and the difficulty in maintaining

the same. It is, however, a smoother operating device than the sectional counterweight arrangement shown in Figs. 3 and 7.

5. Roller Lift Bascules.—The principal commercial examples of this type of construction are the Scherzer and the Rall types, the former put out by the Scherzer Rolling Lift Bridge Company and the latter under patents controlled by the Strobel Steel Construction Company.

Figure 10 illustrates the general features of the Scherzer bridge, the diagram being of a single leaf bascule. The center of gravity of the combined span, counterweight, and counterweight arm is located at point *O*. About this point is described a quadrant *Q* which rolls backward over a horizontal quadrant track resting on the pier. The center

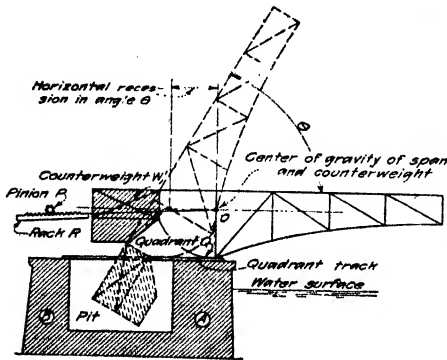

FIG. 10.—Scherzer rolling lift type.



(Courtesy of the Scherzer Rolling Lift Bridge Co.)

FIG. 11.—Typical Scherzer installation—showing counterweight, segmental and track plate castings, and fixed rack method of operation.

of gravity *O* moves backward in a horizontal line a distance *d*, where $d = \frac{2\pi r\theta}{360}$ (*r* being the quadrant radius and θ the angle of opening). Power

may be applied through a pinion *P* rigidly connected to the pier or approach span and engaging a rack *R* fastened to the moving leaf at or near the point *O*. As the span opens and recedes, the counterweight, for deck structures, lowers into a pit provided for the same. For water surface conditions, such as shown in Fig. 10, a watertight counterweight pit must be provided and the pier designed as a unit. For locations sufficiently above high water to permit of such construction, the heavy pier may be replaced by two smaller piers, *A* and *B*, and the quadrant track supported on horizontal girders spanning these piers. This latter arrangement is much less expensive and also relieves the foundations of

much of the churning or rocking action due to the rolling dead load on the unit pier. For through structures the center of the quadrant is generally placed sufficiently high to eliminate the necessity for a pit.

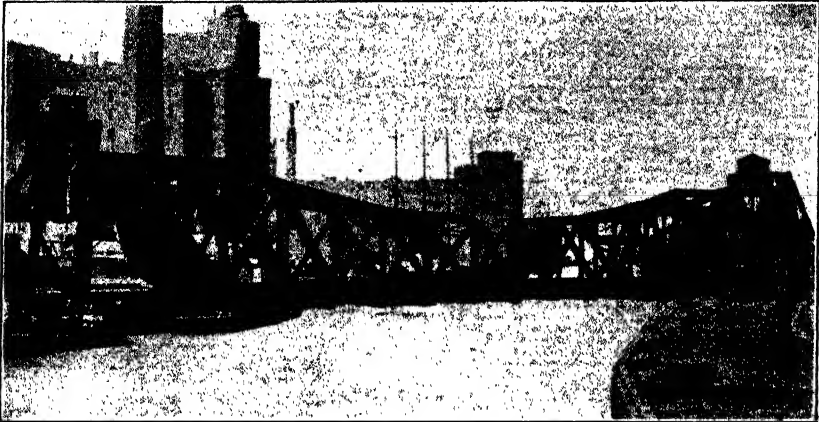

(Courtesy of the Scherzer Rolling Lift Bridge Co.)

FIG. 12.—Scherzer rolling lift span at Grand Central Station, Chicago, Ill.

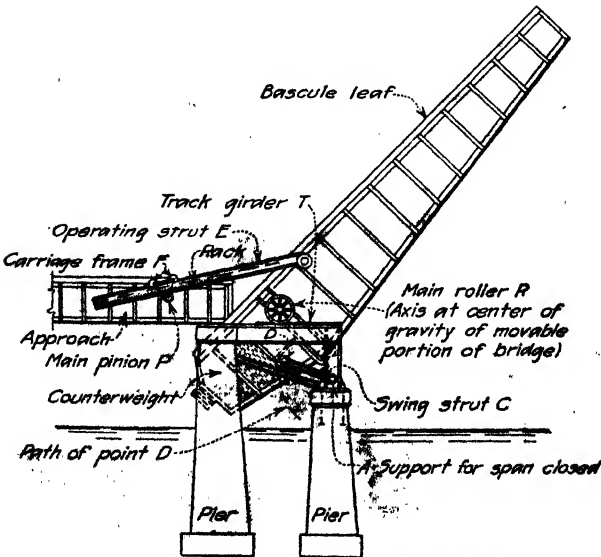

FIG. 13.—Rail type bascule bridge (deck girder span).

For single leaf structures the forward pier is designed in the same manner as for any fixed span. For the double leaf type two abutment piers are needed as well as a device for locking the leaves when they are fully closed. Single leaf spans act as simple spans under live load while

double leaf spans are generally designed to act as cantilevers or partial cantilevers. This point is fully discussed elsewhere.

Figures 13 and 14 illustrate the principal features of the Rall type of bascule bridge, these drawings being developed from certain advertising

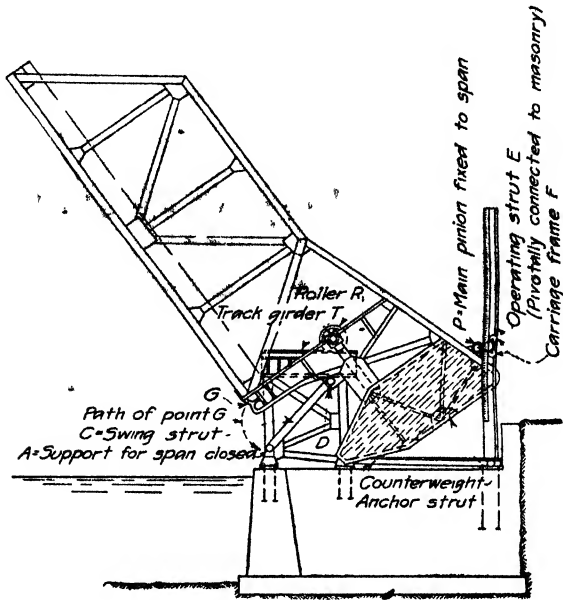
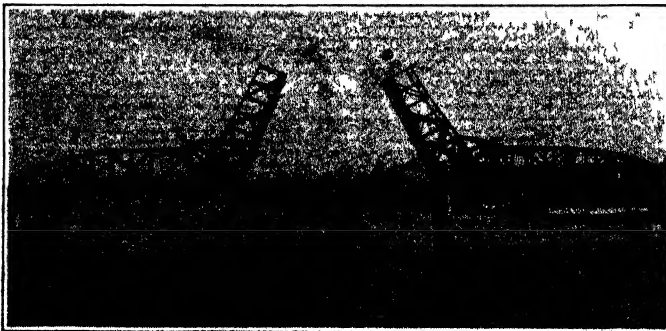

FIG. 14.—Rall type bascule bridge (through truss span).



(Courtesy of the Strobel Steel Construction Co.)

FIG. 15 —Rall type bascule span in operation, Broadway Bridge, Portland, Ore.

matter put out by the Strobel Steel Construction Company who control the Rall patents.

The span is operated by the pinion *P* which engages a rack fixed to the operating strut *E*, this operating strut being maintained in align-

ment by the carriage frame *F*. In the closed position the moving span bears on pin *A*, the roller *R* being raised slightly off the track girder. Thus the load is carried direct through pin *A* to the masonry. As the

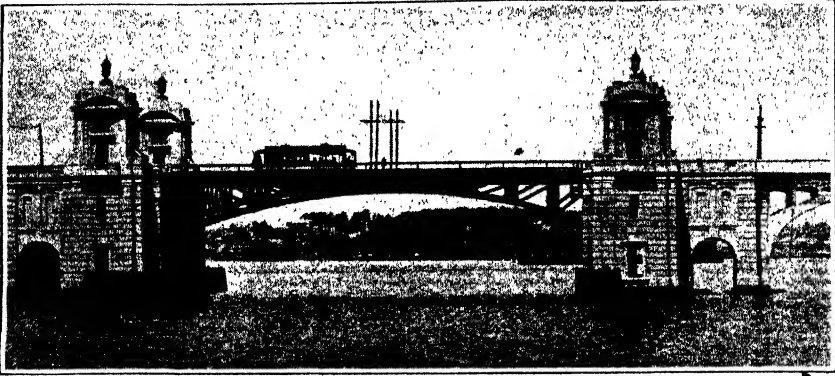

(Courtesy of the Strobel Steel Construction Co.)

FIG. 16.—Architectural possibilities in deck bascule construction. Rall type bascule span, Hanover Street, Baltimore, Maryland.

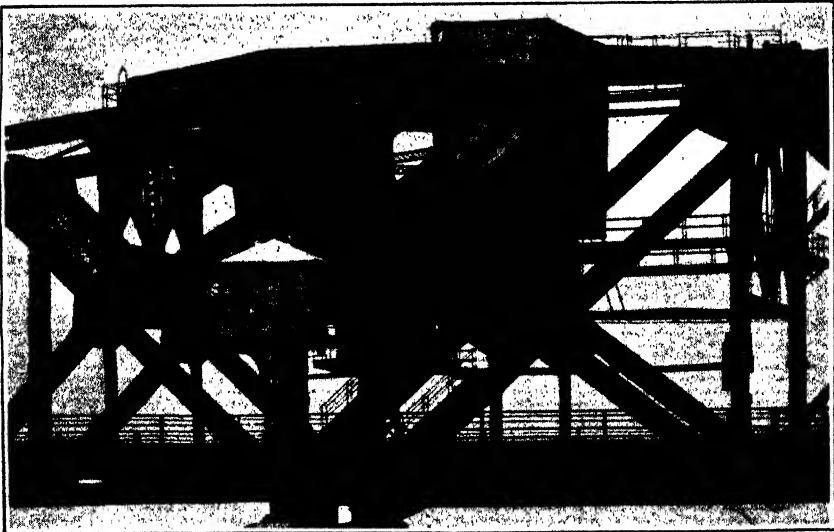

(Courtesy of the Strobel Steel Construction Co.)

FIG. 17.—View showing rollers, track, etc. on Rall type bascule span, Broadway Bridge Portland, Ore.

bridge is opened, the span first revolves about pin *A* as a center until the main roller *R* comes to bearing with the track girder *T*. The span then rolls backward along this track girder, the swing strut *C* causing the connection *D* to describe a circle with center *A* and radius *AD*. This

swing strut thus operates to tip the leaf while the roller *R* causes it to recede.

The center of gravity of the leaf and counterweight is located at the center of the roller *R*.

The distinctive feature of this type consists in the combined rolling and trunnion motion. The roller *R*, being free in the fully closed posi-

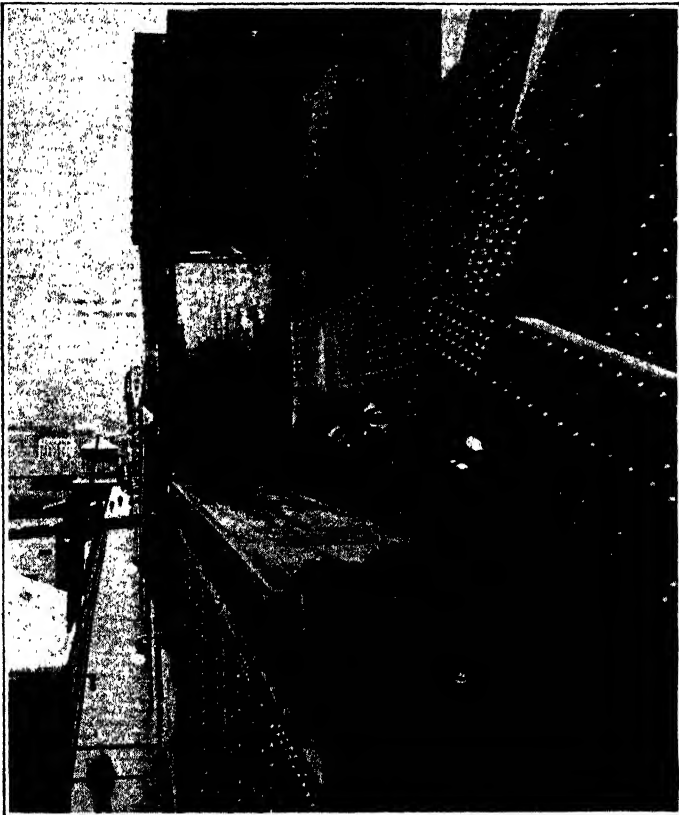

(Courtesy of Strobel Steel Construction Co.)

FIG. 18.—Close view of roller and track, Rall bascule on Broadway, Portland, Oregon.

tion, may be replaced without difficulty. The retreating movement also provides additional clear opening for navigation. The foundations, however, are under a shifting load pressure as in the case of the Scherzer type, but where the design is properly proportioned this latter condition is not at all serious.

6. Trunnion Type Bascules.—The most commonly used bridges falling under this classification are (1) the Simple Trunnion or “Chicago” type, and (2) the Multiple Trunnion type (Straüss type).

6a. Simple Trunnion or "Chicago" Type.—Figure 19 illustrates the simple trunnion principle as applied to a double leaf deck bascule. The entire weight of leaf and counterweight during the operation of opening is carried by the trunnions *T* located approximately at the center of gravity of the mass. These main trunnions are carried in trunnion bearings which in turn are supported directly or indirectly on the masonry of the pier. Figure 19 illustrates a type wherein the trunnion bearings are supported on transverse trunnion girders which in turn are carried by the masonry of the piers. It is also common practice, however, to employ vertical posts or towers underneath the trunnion bearings, thus eliminating the necessity for a transverse girder. The use of longitudinal girders on either side of the trunnion and parallel thereto is

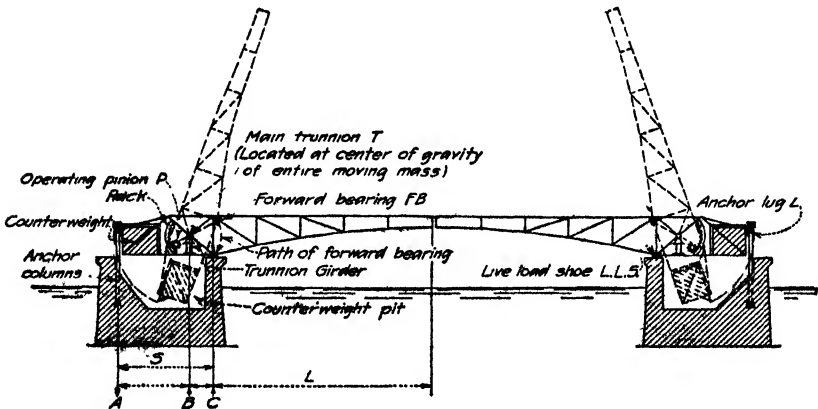

FIG. 19.—Simple trunnion double leaf bascule bridge.

The design here shown employs a transverse girder extending through the truss to support the trunnion bearings. This method of support may be replaced by longitudinal girders parallel to the truss, by vertical columns or towers, or by masonry supports without altering the general scheme of the design or the method of its operation.

also quite frequently employed. It is also possible (by detailing the counterweight with suitable recesses) to support both trunnion bearings directly upon the masonry and thus eliminate the necessity for any towers or girders whatsoever.

The method of supporting the trunnion bearings has been the subject of litigation between certain municipalities and the Strauss Bascule Bridge Company.¹ Strauss claims a patent upon the particular type of trunnion girder illustrated in Fig. 19 wherein the girder is transverse and extends entirely through the truss. Where details will permit, however, it is always advisable to support heavy bearings directly upon masonry supports and thus avoid the deflection in structural members carrying the same. In the subject matter which follows, however, and in the

¹ See p. 23.

illustrative problem, a transverse trunnion girder has been used to illustrate its application. The trunnion bascule with bearings supported on towers, longitudinal girders or directly upon the masonry would involve a procedure no different as regards design.

As the span comes to rest, the forward bearing point FB comes to bearing on the live load shoe LLS , and the rear anchor lug L , attached to the counterweight, engages a seat in the anchor columns, thus causing the leaf to act, under live load, as a cantilever of span L supported at C and anchored at A .

By adjusting the shims under the live load shoe, the span may be made to come to bearing on this shoe slightly before the anchor lugs engage, thus allowing the trunnion bearings at T to lift slightly under live load by removing the dead load deflection from the trunnion supports.



(Courtesy of F. A. Rapp, Bridge Engineer, City of Seattle)

FIG. 20.— University Bridge, Seattle, Washington—double leaf, simple trunnion, bascule span.

The span is operated by means of an operating pinion P rigidly connected with the pier and engaging a circular rack attached to the moving leaf.

This type of structure is sturdy and simple in operation and is unquestionably one of the very best types of bascule bridges in use.

Ivan C. Peterson, Engineer-Manager of the Chicago Bascule Bridge Company, describes the various types of the so-called "Chicago" bascule as follows:

The first example of the so-called "Chicago" type of bascule bridge is the Clybourn Avenue Bridge, which was designed by Edward Willman, City Bridge Engineer, and John Ericson, City Engineer, about 1899. Since then this type has passed through various stages of evolution until at the present time there are 22 simple trunnion bridges in service in Chicago, while two more are in the course of construction. Credit for this further development is due Thomas G. Pihlfeldt, who was for about 22 years the City's Bridge Engineer, and to Hugh E. Young, who, as Engineer of Bridge Design, had charge of the design of practically all the City's "new" bridges built in accordance with the recommendations of the Chicago Plan Commission and having

curved bottom chords and low trusses, as against the straight bottom chord and the deep trusses of the first design.

(1) In Type 1 the trunnion bearings, two for each bascule truss, were supported

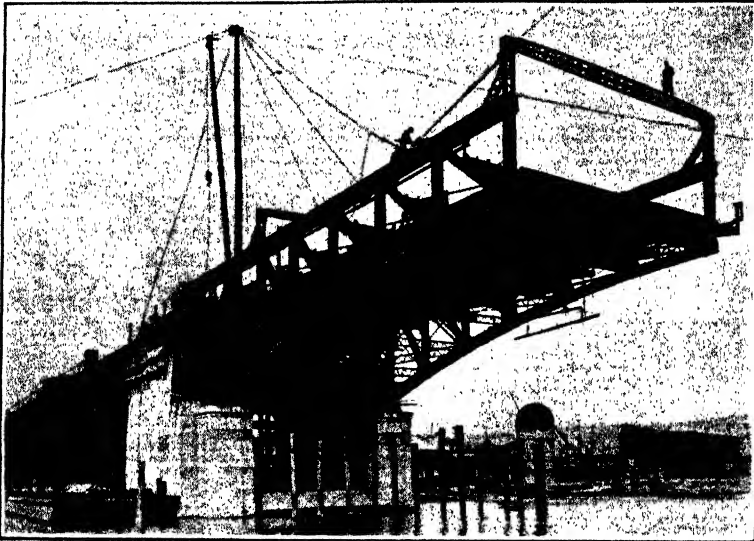

(Courtesy of F. A. Rapp, Bridge Engineer, City of Seattle)

FIG. 21.—Construction view of north leaf of bascule span at 15th Avenue N.W., Seattle Washington—simple trunnion, half through design.

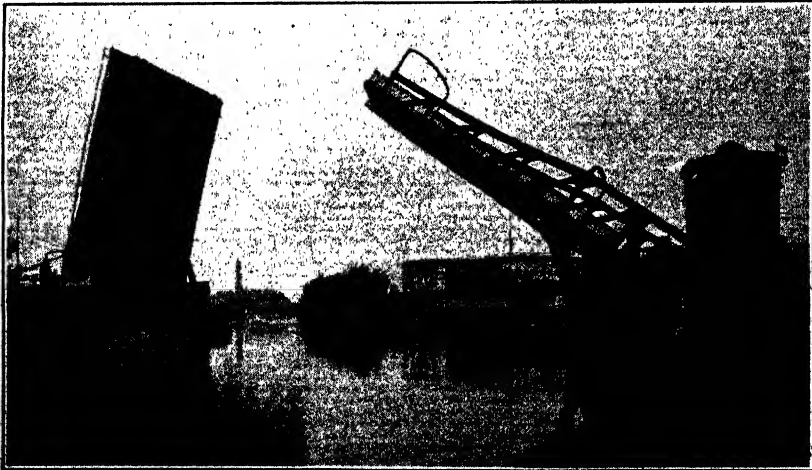

(Courtesy of the Chicago Bascule Bridge Co.)

FIG. 22.—Chicago type bascule bridge, Belmont Avenue, Chicago.

on two box girders, one on each side of the truss extending from the front, or river pier, to the back wall of the pit. The counterweight consisted of cast iron and was confined practically within the truss. The top chord of the rear arm of the bascule truss was

shaped as a quarter circle and formed, in effect, the operating rack, and the machinery was placed in a space back of the pit, the operating pinions engaging the rack quadrants already referred to.

(2) In Type 2, the trunnion bearings are supported on two triangular box girders, or inverted A-frames extending from the front, or river pier, to the back wall of the pit, the rear ends of these trunnion girders, or frames, being carried up high enough so that the counterweight may extend across from one bascule truss to the other, passing under the two inside trunnion supports. The shape of the bascule truss and the location of the machinery is the same as in Type 1.

(3) In Type 3, the arrangement of trunnion trusses and counterweights is the same as in Type 2, but while in Types 1 and 2, the bottom chord of the bascule truss is horizontal, Type 3 has a curved bottom chord giving the general effect of an arched truss, and the top chord does not extend much above the top of the railing. This bridge is operated by means of operating struts, pin-connected to the trusses and operated by a gear train located back of the pit, as in Types 1 and 2.

(4) In Type 4, the arrangement of the counterweight and general outline of the inside trunnion truss is the same as in Types 2 and 3, but the outside trunnion bearing is supported on a horizontal box girder extending from the front, or river pier, to the back wall of the pit. The rack is confined within an opening in the truss and is of concave, or internal type, while the machinery is in two compact units located on the outside of the trusses and supported directly on top of the outside trunnion girder referred to above, and on a machinery girder parallel to, flush on top with, and securely braced against the trunnion girder.

(5) Type 5 differs from Type 4 in one respect only, namely this, that the inside trunnion bearing is supported on a cross girder extending through the opening in the bascule truss referred to above and there is, therefore, no inside trunnion girder or truss.

There are two modifications of this type:

- (a) The outside trunnion girders span freely from the front, or river pier, to the back wall of the pit and support not only the outside trunnion bearing but the end of the cross trunnion girder as well.
- (b) The outside trunnion girder is, in fact, eliminated or is replaced with a much smaller girder serving rather as a machinery support, and the load on the outside trunnion bearing as well as the reaction from the cross trunnion girder is carried down into a subpier located directly under the side wall of the pit at this point.

Through a sensational lawsuit which was decided in favor of the Strauss Bascule Bridge Company, Type 5 was adjudged to infringe U. S. Patent 995813, belonging to the Strauss Bascule Bridge Company, insofar as the cross girder extending through openings in the bascule trusses is concerned.

On the other hand, the employment of the opening in the truss for locating therein an internal or concave rack is covered by U. S. Patent 1001800, issued to Alexander Von Babo in 1911; we are licensees for the use of this patent. The drawings attached to this patent show the general arrangement of Type 5, but of course, the suit which judged the cross trunnion girder an infringement of Patent 995813, automatically voided the claims in Patent 1001800 covering this feature, and with this feature omitted, Type 5 reverts to Type 4.

The Belmont Avenue Bridge, shown in Figs. 30, 31 and 32, is of Type 4. These illustrations clearly show:

- (a) The general appearance of the finished structure (see Fig. 22, p. 22).
- (b) The arrangement of trunnion girders and trusses, also anchor posts (see Fig. 30).
- (c) The framing of the movable span which shows that the bottom lateral system extends from the front end of the leaf and nearly to the trunnion

center, when it is interrupted for only a short distance and then continued in the counterweight box itself, which forms a most rigid and solid brace between the tail ends of the bascule trusses (see Fig. 31).

- (d) The compact arrangement of the operating machinery. In this particular bridge, the shaft bearings were bolted directly to the machinery girders, but in later structures of this type, the bearings are integral parts of a complete cast steel machinery frame or base, which permits the complete assembling, adjustment and testing of the gear train before shipment (see Fig. 32).

6b. Strauss Type.—There are several designs put out by the Strauss Bascule Bridge Company, the most distinctive being (1) the Overhead Counterweight type, and (2) the Heel Trunnion type.

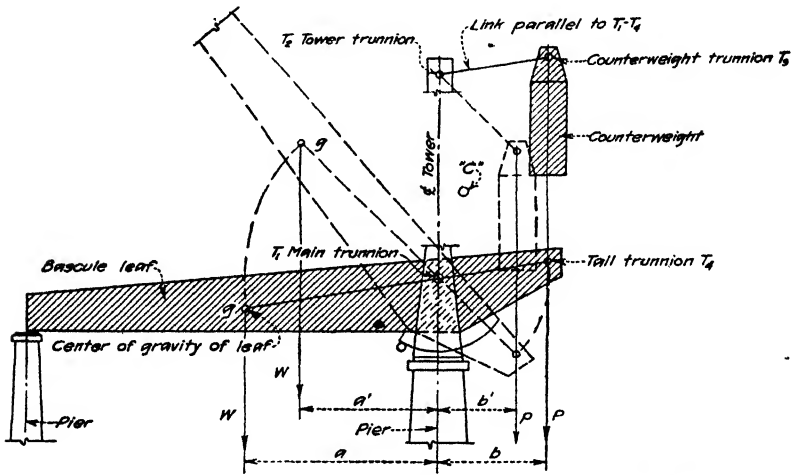

FIG. 23.—Strauss "Overhead Counterweight" bascule bridge.

Figure 23 illustrates the general outline of the Strauss overhead counterweight design, the distinctive features of which are the four trunnions T_1 , T_2 , T_3 and T_4 , forming with their connecting struts, a parallelogram.

The tail trunnion T_4 is placed on a line passing through the center of gravity g of the moving leaf and the main trunnion T_1 . The link T_2-T_3 is made parallel to T_1-T_4 , also the lines T_1-T_2 and T_3-T_4 are parallel. The following conditions of equilibrium therefore obtain

$$Wa : Wa' :: Pb : Pb'$$

This relationship is true because of the fact that g , T_1 and T_4 lie in a straight line and also because the parallelogram $T_1-T_2-T_3-T_4$ causes the pivoted counterweight to move parallel to itself.

The principal advantage of this arrangement lies in the fact that the main trunnion T_1 may be located at any point desired (T_4 being, of

course, located accordingly). Thus, it is possible to put the trunnion T_1 at the point shown and place the counterweight *above* the roadway even though the center of gravity of the entire mass (leaf and counterweight) would be at some point such as C . The principal disadvantage lies in the number of intermoving parts and the hinged and swinging counterweight.

The Strauss "Heel Trunnion" type is illustrated in Fig. 24.

T_1 is the main leaf trunnion, T_4 the counterweight trunnion, and T_1, T_2, T_3 and T_4 together with their connecting struts form a parallelogram. A line is drawn through T_1 and g the center of gravity of the moving span, and the center of gravity g' of the counterweight is made to lie on a line through T_4 parallel to $g-T_1$. We then have $Wa : Wa' :: Pb : Pb'$, and a

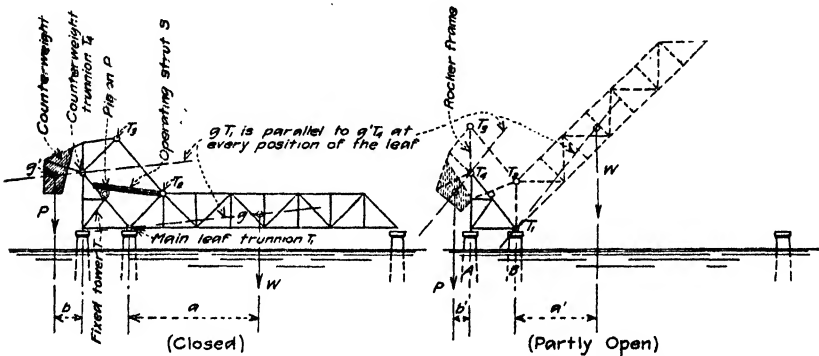

FIG. 24.—Strauss "Heel Trunnion" type bascule bridge.

condition of constant balance is maintained. This proportionality is maintained during the operation of the bridge by means of the trunnion parallelogram $T_1-T_2-T_3-T_4$. The bridge is operated by means of the strut S attached to the moving leaf and fitted with a rack engaging the pinion P rigidly fastened to the fixed tower T . As the moving leaf rises, the trunnion parallelogram folds up and the shore end of the rocker arm lowers, causing the counterweight to move downward. Pier A supports the counterweight and Pier B supports the moving leaf under dead load.

The Strauss Company also put out a design known as the "Strauss Underneath Counterweight" type in which the counterweight principle is identical with that of the "Overhead Counterweight" type above described, but with the counterweight and link located underneath the roadway. This arrangement is particularly adapted to locations which provide ample clearance between high water level and grade.

7. Semi-lift Bascule Spans.—The direct lift bascule is, properly, not a bascule span at all, but one that belongs in the vertical lift classifica-

tion. Because they operate on the bascule principle, however, a brief discussion may be of interest.

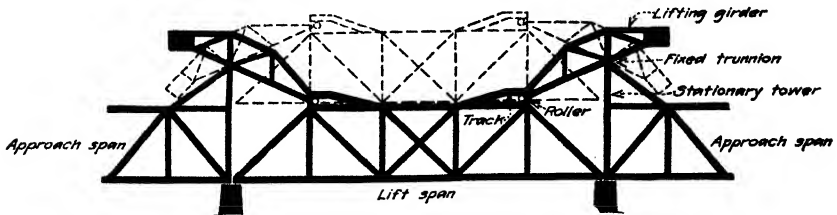

Note: Counterweighted lifting girders rotate about fixed trunnions supported by stationary towers.

FIG. 25.—Rall direct lift span (Type A).

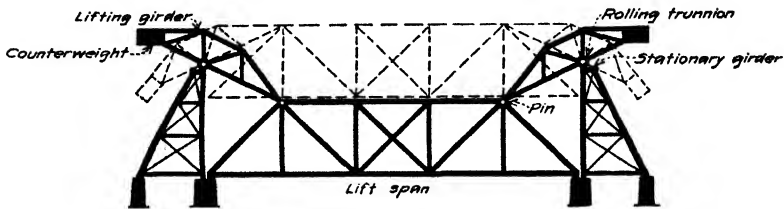

Note: Counterweighted lifting girders are attached to lift span and roll on stationary girders.

FIG. 26.—Rall direct lift span (Type B).

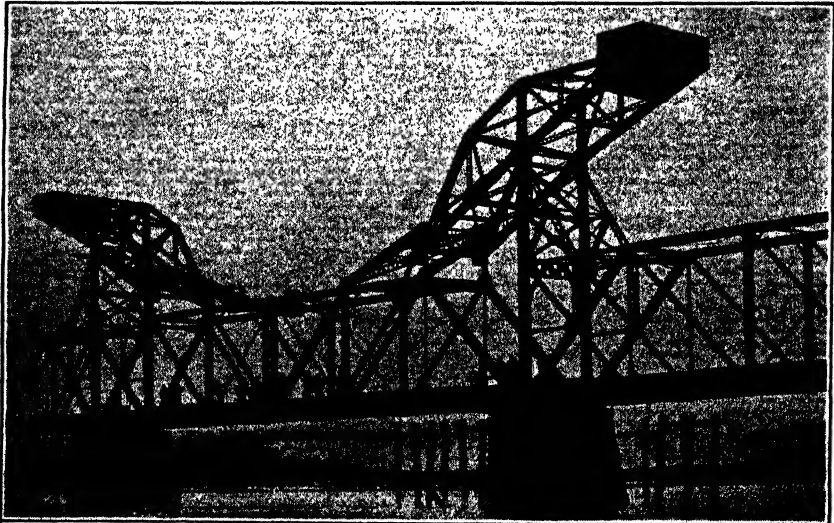

(Courtesy of the Strobel Steel Construction Co.)

FIG. 27.—Rall type, semi-lift span, C. B. & Q. Railroad near La Salle, Ill. (Span closed.)

The Rall type vertical lift span is illustrated in Figs. 25 and 26, which are taken from descriptive matter put out by the Strobel Steel Construc-

tion Company. There are two types shown, differing in minor detail of operation; these are completely explained by the drawings. This type of span is applicable to spans requiring a head room, when open, of not over about 150 ft. and presents the advantage of being applicable to the modification of existing fixed spans.

The Strauss Bascule Bridge Company also put out a semi-lift type operating in the same general manner.

Figures 27 and 28 are views of a Rall type, semi-lift span in operation.

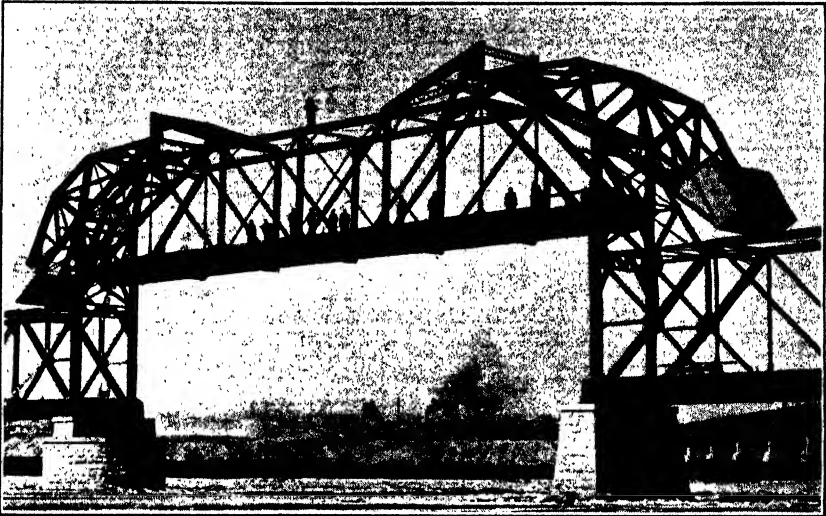

(Courtesy of the Strobel Steel Construction Co.)

FIG. 28.—Rall type semi-lift span, C. B. & Q. Railroad near La Salle, Ill. (Span open.)

8. Other Types of Bascule Spans.—There are several other types of bascule construction which have been introduced from time to time. Some of these have been quite successfully used, others have been quickly abandoned in favor of the more standard types described above. The Brown Bascule, built in Buffalo, N. Y., and the Waddell and Harrington type, built in Vancouver, B. C., are examples of successful bascule construction outside the types herein described. The roller bearing bascule of Cowing and of Montgomery Waddell and the tilting floor bascule of Page and Schnable are other examples of interesting design along this line. Dr. J. A. L. Waddell in his "Bridge Engineering" gives a very interesting discussion of many of these types.

Space will not suffice for even the briefest mention of the many bascule types for which U. S. Letters Patent have been granted. For the benefit of those who wish to collect further information along this line a partial list of bascule patents granted by the U. S. Patent Office is herewith appended.

LIST OF U. S. LETTERS PATENT GRANTED FOR BASCULE BRIDGE AND ALLIED CONSTRUCTION

Number	Sub-class	Patentee	Remarks
173253	36	M. B. Adams	Bascule
983194	41	R. M. Agnew	Drawbridge
1001800	..	Alexander F. L. Von Babo	Bascule
1048440	39	F. J. Benni	Bascule
442847	36	S. Bergman	Drawbridge
828873	36	F. G. Borg	Bascule
632985	38	W. L. Brayton	Bascule
587926	36	W. H. Breithupt	Drawbridge
590787	36	T. E. Brown	Drawbridge
1151657	36	T. E. Brown	Bascule
1203695	36	T. E. Brown	Bascule
1210410	41	T. E. Brown	Bascule
1251634	36	T. E. Brown	Bascule
1254772	36	T. E. Brown	Bascule
1254773	36	T. E. Brown	Bascule
1270925	36	T. E. Brown	Bascule
1302302	36	T. E. Brown	Bascule
683811	38	J. P. Cowing	Bascule
644405	38	J. P. Cowing	Bascule
665405	38	J. P. Cowing	Bascule
672848	38	J. P. Cowing	Lift bridge
689856	38	E. D. Cummings	Lift bridge
1224629	36	R. D. Gardner	Lift bridge
694744	40	C. F. Hall	Bascule
708348	40	C. F. Hall	Bascule
383880	37	W. Harman	Bascule
952485	36	J. L. Harrington	Bascule
554390	41	E. B. Jennings	Drawbridge
780193	41	J. A. Joyce	Bascule
721918	39	C. F. T. Kandeler	Bascule
735414	39	C. F. T. Kandeler	Bascule
685707	41	C. L. Keller	Bascule
752563	40	C. L. Keller	Bascule
1047950	38	C. L. Keller	Bascule
1042238	41	K. C. Krause	Bascule
173253	36	F. L. Krause	Bascule
503377	37	R. P. Lamont	Bascule
503378	36	R. P. Lamont	Bascule
544733	36	R. P. Lamont	Bascule
657122	39	F. La Pointe	Lift bridge
1124922	36	C. G. E. Larson	Lift bridge
1078293	37	B. Leslie	Drawbridge
1128478	40	C. McKibben	Bascule
1241237	36	C. H. Mercer	Bascule
180491	39	G. Moody	Drawbridge
1311284	36	S. Morreell	Bascule
719153	40	S. T. Metters	Lift bridge
824135	36	R. E. Newton	Bascule
843167	38	J. P. Nikonow	Cantilever bridge
873923	36	J. W. Page	Bascule
731321	38	J. W. Page	Bascule
731322	36	J. W. Page	Bascule
12570	40	T. Rall	Bascule
817516	40	T. Rall	Bascule
1094473	38	T. Rall	Bascule
511713	39	W. Scherser	Lift bridge

Number	Sub-class	Patentee	Remarks
721918	39	A. H. Scherzer	Bascule
735414	39	A. H. Scherzer	Bascule
963399	40	A. H. Scherzer	Bascule
968987	41	A. H. Scherzer	Bascule
968988	41	A. H. Scherzer	Bascule
978493	41	A. H. Scherzer	Bascule
1021488	39	A. H. Scherzer	Bascule
1041885	39	A. H. Scherzer	Bascule
1104318	39	A. H. Scherzer	Bascule
1109792	40	A. H. Scherzer	Bascule
1114535	39	A. H. Scherzer	Bascule
517809	39	M. G. Schinke	Drawbridge
551004	39	M. G. Schinke	Drawbridge
564164	38	E. S. Shaw	Bascule
887131	86	L. H. Shoemaker	Lift bridge
738954	38	J. B. Strauss	Bascule
894239	39	J. B. Strauss	Bascule
995813	..	J. B. Strauss	Bascule
1124356	36	J. B. Strauss	Bascule
1150643	38	J. B. Strauss	Bascule
1150975	38	J. B. Strauss	Bascule
1157449	41	J. B. Strauss	Bascule
1170703	38	J. B. Strauss	Bascule
1171553	38	J. B. Strauss	Bascule
1211639	36	J. B. Strauss	Bascule
136278	38	S. Swartz	Lift bridge
172204	38	S. Swartz	Lift bridge
911628	38	E. Swenson	Lift bridge
496074	36	G. H. Thompson	Drawbridge
648447	40	F. G. Vent	Bascule
598167	39	M. Waddell	Drawbridge
598168	39	M. Waddell	Lift bridge
621466	38	M. Waddell	Lift bridge
637050	40	M. Waddell	Bascule
660827	36	M. Waddell	Bascule
661113	38	M. Waddell	Bascule
693467	38	M. Waddell	Lift bridge
890947	38	M. Waddell	Lift bridge
908713	40	M. Waddell	Drawbridge
952485	36	M. Waddell	Bascule
789398	39	W. J. Watson	Bascule
442847	36	G. A. Weidenmayer	Drawbridge
534704	37	B. L. Worden	Drawbridge
536313	39	B. L. Worden	Drawbridge
691035	36	J. D. Wilkins	Lift bridge
1241237	36	C. H. Woethle	Bascule

SELECTION OF TYPE OF BASCULE BRIDGES

9. Single vs. Double Leaf.—A great many factors are involved in the problem of selection of type of bascule for use at a given location. Some of these factors should be known even before the site is chosen. Others can be determined by a careful topographical survey of the selected location. Still other factors are made known by the results of test borings and other exploration of the foundations. The economics of

cost of substructure and superstructure for the various types can be determined only after comparative designs and careful estimates have been worked out.

It is the intent of this chapter to outline a few of the more important points to be considered and to call attention to the fundamental differences in the various types in so far as these differences may dictate the selection of the ultimate design.

The first question in selecting a type of bascule bridge is usually whether one leaf or two shall be used.

The advantages of the double leaf construction over the single leaf are:

- (1) Added safety to roadway traffic.
- (2) Increased speed of operation.
- (3) Greater adaptability to esthetic treatment.
- (4) Decreased size of individual operating units.
- (5) Lower overturning moments on piers due to wind on upraised leaf.
- (6) Shorter counterweight arms or smaller counterweights, or both.
- (7) Increased head room at center of channel (in the deck or half through types).

Taking these up in the order given above: The added safety to roadway traffic is due to the fact that practically all types of bascules may be so arranged that either the rear end of the moving floor or else the counterweight forms a solid barricade across the roadway when the bridge is fully raised, while on a single leaf bridge the outer end raises and leaves the open end of the fixed roadway protected only by a gate or other light barricade. In certain types of the Rall rolling lift, the Strauss vertically moving overhead counterweight, the Strauss Heel Trunnion Pantograph type and the Scherzer rolling lift with overhead counterweight, the counterweight generally forms this barricade. In the Chicago type simple trunnion bascule and in practically all of the other underneath counterweight types, the roadway floor on the moving leaf forms the barricade when the break between the fixed and moving floor is ahead of the trunnion as it should preferably be on single deck bridges. The roadway floor probably constitutes a better and more certain roadway barricade than does the lowered counterweight particularly in locations where a large portion of the lifts will be to less than full height. Either type, however, furnishes a barricade much safer and more certain than can reasonably be expected for a single leaf design. In substance therefore, a double leaf bascule effectually protects both approaches while a single leaf bascule leaves one approach unprotected.

The greater speed of operation for the double leaf construction is due to the fact that for a given opening at the center of the channel, two leaves can be raised simultaneously in a shorter space of time than one

leaf can be raised to twice the desired opening at the far pier. The leaves of the double leaf type, being shorter, are lighter and have less inertia to be overcome by the machinery. The acceleration is therefore faster than with the single leaf.

In consideration of esthetics the double leaf lends itself readily to a balanced treatment, both piers and leaves being symmetrical. The stresses in the trusses of a double leaf bridge are a maximum at the piers and a minimum at the center of the channel. The double leaf, therefore, is economical when a curved chord cantilever is desired in order to give the effect of an arch when closed.

On account of the decreased inertia and lighter weight (because of the shorter leaf and the smaller area exposed to probable wind pressure), the individual items of machinery required to operate the double leaf type will be lighter than those for the single leaf type, although the total weight of operating machinery may be about the same.

In the same degree that the wind pressure is reduced, the overturning on the pier and thereby the maximum soil pressure is also reduced. For each leaf, the area exposed to wind pressure is half for the double leaf type of what it is for the single leaf type. The moment arm also being half, the resulting moment is therefore, only one-fourth. This is a very important consideration where the foundations are in soft material or on piling.

The moving leaf is shorter and lighter on the double leaf type, therefore, in the fixed counterweight types the counterweight arm may also be shorter and the size of the counterweight reduced, thus reducing the required distance from the grade of the roadway to high water elevation. This effect is more than directly proportional to the length of the leaf because the lighter truss, as above noted, has also a shorter lever arm. In the case of the pivoted counterweight and overhead counterweight types, the above relation is true, particularly in regard to the size of counterweight. The saving in length of counterweight arm may be sufficient to just avoid dipping beneath the water line with the counterweight arm when the bridge is raised and therefore, may mean the difference between a watertight counterweight pit for a single leaf as against an open air clearance for the double leaf type. This consideration often becomes a determining one in locations where the roadway grade must lie close to the water surface.

In the double leaf type, the counterweights, as above noted, are much smaller than in a single leaf bridge of equal channel span on account of the lessened weight and moment arm of the overhanging leaf. There is, therefore, considerable economy of counterweight material itself in the double leaf type.

In the double leaf types, the adoption of a shallow section at the ends of the cantilever arms to give the closed span an arch effect and also to

save metal at the center, increases the available head room at that point thus permitting a relatively greater percentage of the shipping to pass under the closed bridge.

The advantages of the single leaf type over the double leaf are:

- (1) Centralized power plant and control.
- (2) Greater rigidity under excessively heavy live loads.
- (3) Only one counterweight pit to provide (where the roadway is so close to water line as to make a pit necessary and where an underneath counterweight type is to be chosen).
- (4) Absence of the necessity for anchoring the rear end of overhanging arm for live load with a consequent lessening of the churning action on the foundations.

Referring to the above points: The advantage of a single control and mechanical plant is obvious. There is but one machinery room, the limit switches and interlocking devices are greatly simplified and cheapened and the use of steam or gas as a motive power is made possible in localities where electric power is not available or not satisfactory. Where electric power is employed, or where gas or steam must be used in conjunction with electricity, a submarine cable is necessary with the double leaf type for the control of the remote leaf. Remote control for the operation of the far leaf has been very highly developed and is perfectly safe and certain, the only objection to the same being that it is expensive from a standpoint of first cost and because it requires the presence of an operator familiar with the electrical wiring of specialized equipment. In localities where the underneath counterweight is desirable from an esthetic standpoint or for other reasons, but must be provided with a watertight pit on account of the proximity of the grade line to water line, it is quite possible that the saving effected by the elimination of one pit through the use of a single leaf design may offset the losses due to the various other considerations against the single leaf type.

The double leaf type generally acts as a cantilever under live load and must therefore be anchored at the rear. The single leaf type acts as a simple span under live load and hence needs no anchorage.

One of the greatest advantages of the single leaf type is the elimination of the necessity for this anchorage at the heel of the truss inasmuch as this anchorage detail in double leaf designs is the cause of considerable churning action on the piling or foundation soil and a consequent increase in extreme pressure at the toe of the footing. Whether or not the increase in live load toe pressure on the double leaf design due to the above cause is offset by the decreased toe pressure due to the fact that wind pressure on the upraised leaf is much less, can only be determined by analysis of each individual case.

In general it will be found that for heavy loads or for short spans, the single leaf type will be the more economical while for lighter loading or for

longer spans, the double leaf will be cheaper. In corroboration of the above principle, it should be noted that single leaf types are more common for railway than for highway loadings and that practically all spans of less than 100-ft. clear channel are single leaf designs. No small part in the selection of these types is played by the fact that the double leaf design gives the more sightly structure and lends itself to balanced architectural treatment, being for this reason a preferable type for highway and municipal bridges, while the single leaf, through truss type is far stiffer under heavy engine and train loadings and is therefore, more desirable for railway work where esthetics are to a certain extent secondary.

10. Through vs. Deck Spans.—In addition to the well known considerations which have a bearing on the selection of through *vs.* deck trusses for ordinary fixed spans, the bascule bridge involves certain factors relating to location and size of counterweights and to the location of the trunnions and their supports.

In any type of bridge where the counterweight is fastened rigidly to the moving leaf, it is necessary that the line through the centers of gravity of the overhanging or river arm, and the rear or counterweight arm must pass through the center of rotation in order that the moving part may always be in equilibrium

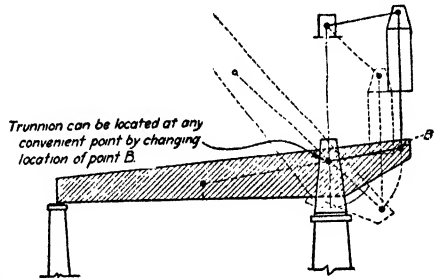

FIG. 29.

without assistance from the machinery. In those types where the counterweight is linked to the moving span, but not rigidly connected thereto, the distance in a horizontal line between the main trunnion and the center of gravity of the moving leaf must always bear a fixed ratio to the horizontal distance from the point of rotation of the counterweight to the center of gravity of the same. (This relationship is due to the fact that the summation of moments tending to rotate the span about the trunnion; must always equal zero for equilibrium and therefore, the ratio of the horizontal arm of the moving leaf to the horizontal arm of the counterweight must always be in inverse proportion to the ratio of weights of moving leaf and counterweight.¹)

It will readily be seen, therefore, that if the trunnion for a through truss were located at the lower chord end panel point *LO*, the counterweight would need to be below the deck of the fixed approach if it were to be rigidly connected to the moving leaf because the center of gravity

¹ For purposes of operation, it is generally considered advisable to so arrange the relation between the center of gravity of the moving system and the center of rotation that the channel leaf will be overbalanced very slightly when closed. This, however, is discussed more fully in Art. 13, p. 39.

of the truss would lie above the trunnion and, from the above consideration, a line from the center of gravity of the truss through the trunnion

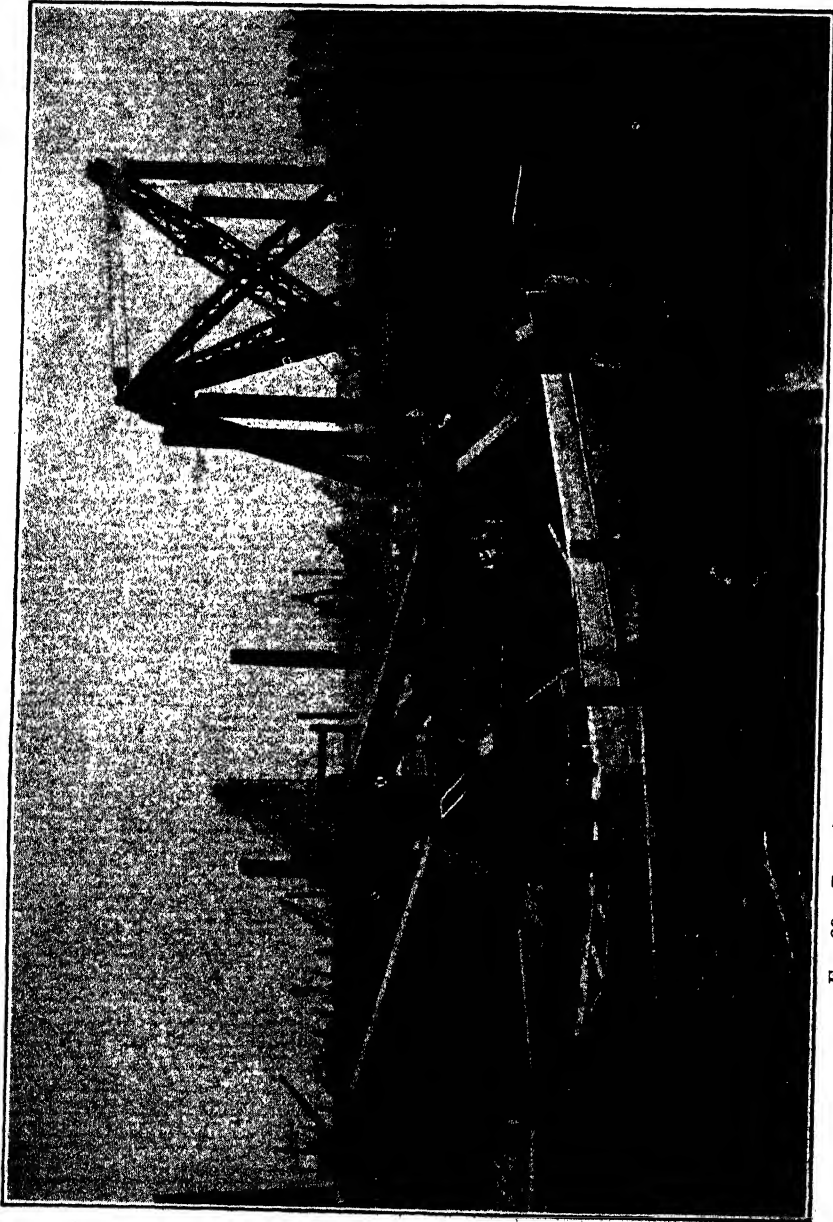

Fig. 30.—East abutment, Belmont Avenue Bridge, Chicago, Oct. 5, 1915.

when produced rearward must constitute the locus of the center of gravity of the counterweight. The type shown in Fig. 29, on the other hand,

permits the main trunnion to be placed at or near the heel and at the same time, permits the employment of an overhead counterweight. The type shown in Fig. 33, p. 40, also permits of the construction of a through truss with heel trunnion and overhead counterweight.

The case first cited above, *viz.*, a through truss with heel trunnion and fixed counterweight, would require enough metal at *LO* to withstand the



FIG. 31.—East abutment, Belmont Avenue Bridge, Chicago, Feb. 1, 1916.

bending moment caused by the counterweight and this, for any ordinary span, would be prohibitive. If, however, the trunnion is raised to a position between the chords of the truss and the truss extended rearward to the counterweight connection, it is possible to place the counterweight rigidly between the rear ends of the trusses and have its center of gravity in line with the center of gravity of the forward end and the center of the trunnion. This gives the simple trunnion type as illustrated in Fig. 31 and changes the design from a through to a half through or deck type.

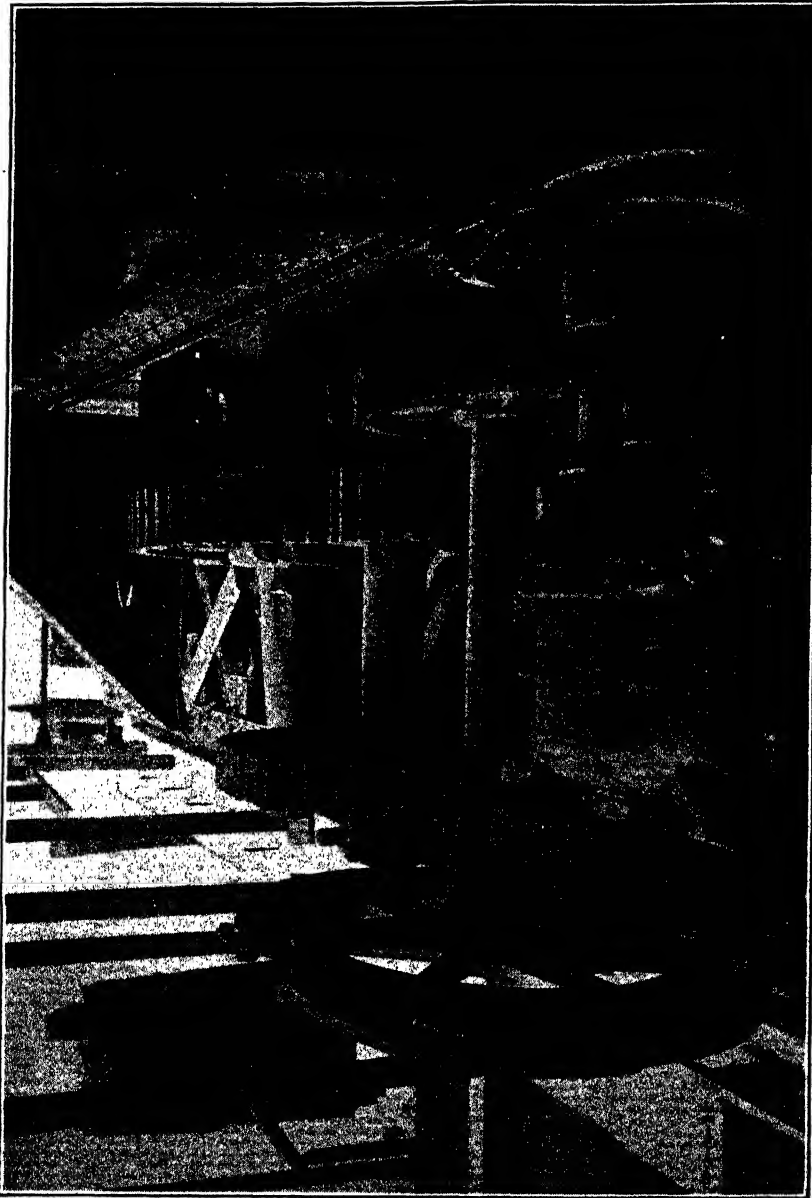

Fig. 32.—Operating machinery, West Side, Belmont Avenue Bridge, Chicago.

It is also possible to obtain a deck structure with a heel trunnion and overhead counterweight although considerations of headroom at high water generally confine this type to short spans.

Advantages of the deck type are: The possibility, as a general rule, of securing more rigid bearings for the trunnions; more slightly structures; better chance to develop the lateral system in the counterweight arm, thereby stiffening the whole moving leaf; and lastly, greater safety to roadway traffic as the operator has a much better view of the roadway on a deck span than he does on one where the truss members are above the floor.

Some of the disadvantages of the deck type are: The added height of roadway necessary, making the approaches steeper; the difficulty in general of arranging dimensions and details to allow the break in the floor to be placed ahead of the point of rotation (thereby making the moving leaf to act as an effective barrier to the roadway traffic); added height of counterweight tower posts in the overhead counterweight types; added length of channel span in the trunnion types which have trunnions in or near the line of the top chord. As a general rule, it may be said that the higher the floor is placed above the bottom chord, the more difficult become the details. Particularly is this true in regard to the interference of moving parts; many cases having arisen where it has been impracticable to obtain a deck structure and still keep the break in floor ahead of the center of rotation. The reasons for this are not easily demonstrated, but the designer will soon find whether his design can be made a deck structure or whether the limiting conditions in the case, as above discussed, make that type out of the question.

11. Arrangement of Piers.—There are several types of piers used to support bascule spans. Some of these are common to several types of bascules while others are adaptable to only one type. Whatever applies to the operating, or hinged, end of a single leaf type also applies to the hinged ends of a double leaf type.

In general a forward and a rear pier are required for the operating end of any bascule. The simple trunnion type has a live load or forward pier, a trunnion pier and (if a double leaf type) an anchor or rear pier. The Strauss trunnion type generally has the same piers and the Scherzer type has a track between a forward and a rear pier, or else a solid wall which is equivalent to a beam over the two supports. The Rall also uses a track, but frequently supports one end of this track on a stream pier and the other on an approach. The Page bascule, in which the weight of the approach is utilized as a counterweight, must have a forward pier for the heel of the river arm and a rear pier for the heel of the approach arm.

A forward and a rear pier are usually necessary on account of the fact that the possible overturning moment of the wind on the open, or partially open span is very great and enough mass and base area must be

furnished by the pier or piers to render the structure stable under maximum wind pressure on the upturned leaf. Some designers have succeeded in using the approach span as a connecting link, thereby causing the pier at the shore end of the approach span to act as the rear pier and take part of this overturning moment.

Wherever the counterweight is clear of the water at the fully open position of the leaf, the individual piers will probably prove the cheaper method of support, but where the counterweight swings below high water, it will be necessary to build a watertight pit into which the counterweight may swing. In this case, the unit pier construction has the advantage and the final design will resemble an open box generally with individual piers against the inside walls; the whole being placed on a solid foundation slab. The overhead counterweight will practically always call for simple individual piers while for the underneath counterweight design, the type of pier needed will depend upon the distance from roadway to water level. In the wing counterweight type, the weights are almost always so arranged that they do not fall below the line of the top of the pier and so rarely need a watertight pit.

12. Relative Merits of Different Types.—There are in use in the United States and foreign countries at the present time four principal types of bascules. These have been described in a general manner in the foregoing pages. They are: (1) Scherzer; (2) Strauss; (3) Chicago, or Simple Trunnion; and (4) Rall. It is probable that there are in existence more bridges of either one of the four above mentioned types than all other miscellaneous kinds combined. A glance at the list of patents on pp. 28 and 29 will show that there are a great number of patented bascules which have never been built and that the four types mentioned above comprise a large part of the patents. It is true that some of the patents are for improvements and for small parts in existing types, and not for separate and distinct types of bridges. Most of the patents, however, cover some basic idea of bascule design in relation to the whole superstructure and its method of operation. The fact that some of these types have not been built quite likely indicates either that they were too costly, or that further investigation has shown the basic idea to be impractical. At any rate, the result has been that construction has narrowed down at the present time to practically the four types mentioned above.

In the number of bridges of each type in operation, it is probable that the Scherzer leads, the various types of Strauss coming next, the Chicago or Simple Trunnion being third, and the Rall last.

BASCULE SUPERSTRUCTURE DESIGN AND ERECTION PROBLEMS

In this chapter, it is not the intention to treat of that portion of the design of a bascule bridge superstructure which involves the same

procedure as that for the design of any other steel frame work. There are many points, however, which are very different from ordinary fixed bridge design. It is with such special features that this chapter has to do.

13. Balance Requirements.—The main difference between a fixed bridge and a bascule lies, of course, in the fact that the latter is a moving structure. In order that the machinery required may be as light as possible, it is necessary to have the moving portion always in balance so that inertia, friction and wind are the only loads on the machinery. The designer of the structural portion must, therefore, bring the center of gravity of the moving leaf to a coincidence with the center of rotation. The moving leaf is best handled by considering it in two complete items: (1) All the moving portion except the concrete counterweight, and (2) the concrete counterweight.

The best method of procedure seems to be to choose tentatively the number of leaves desired, the type of bascule to be used, the length of span, the elevation of grade (thus giving the distance from grade to high water) and all other limiting conditions and then to make a rough layout of this tentative plan to determine whether all the conditions can be fulfilled. From this sketch, the amount of clearance from grade to high-water will show whether an underneath counterweight can be used. The length of river arm can be determined so as to provide the necessary clear channel and the question of deck *vs.* through bridge decided. Several trials and layouts are usually necessary before all points of interference are located and corrected. These points being settled, the final design may be started.

Since the portion of the structure between the forward or channel piers can be designed with certainty regardless of the shape, support required for, or the placing of the counterweight, it is advisable to consider first the bridge in the closed position and design the river arm for dead and live load closed. This gives the weight and center of gravity of the river arm and, as the limiting dimension between grade and water line will fix very closely the length of the counterweight arm, a close approximation can be made (1) of the weight and center of gravity of the steel in the rear end, and (2) of the amount of concrete required in the counterweight. Having these data and the shape of the forward arm, the line from the center of gravity of the proposed counterweight to the center of gravity of the rest of the moving leaf will constitute the locus of the center of rotation for any bascule having a rigidly attached counterweight (see Fig. 52, p. 51).

For bascules with a trunnioned or hinged counterweight, the line from the counterweight trunnion to the center of gravity of the moving leaf is the locus of the center of rotation (see Fig. 54, p. 52).

In the Strauss type of overhead counterweight which has the parallelogram connection between the counterweight and the truss (see Fig. 33a),

the point of rotation of the truss is fixed at H (the heel of the truss) and the line through the center of gravity G of the moving leaf and the trunnion H must be parallel at all times to the line CT , where C is the center of gravity of the counterweight. This may be readily seen from the following consideration: If we consider the parallelogram $T-L'-L-H$ as of no width, thus bringing the counterweight trunnion T and the main trunnion H to the same point, the length of lines TH and LL' become equal to zero and the line TC becomes a continuation of line GH . The

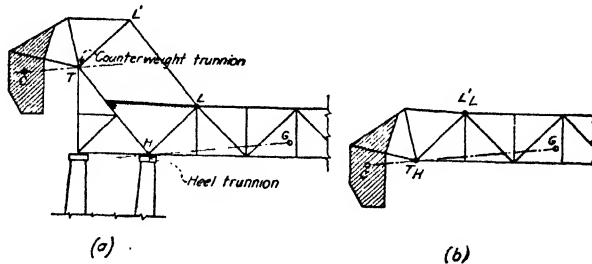

FIG. 33.

moving portion can then be considered as a simple trunnion type as shown as in Fig. 33b. From this treatment, it is seen that the law above stated must hold, *viz.*—that, for the type shown in Fig. 33a, the locus of the center of gravity of the counterweight is a line through T parallel to the line GH and extending toward the rear.

When the point of rotation is not yet fixed, as is the case when designing the vertically moving overhead counterweight type (see Fig. 53, p. 52), the point of connection of the counterweight to the moving leaf is considered as the counterweight trunnion and the rule stated above for trunnioned counterweights applies.

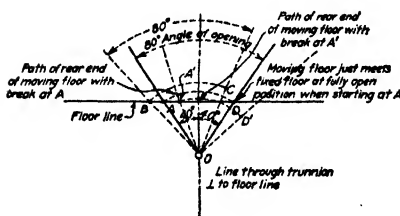

FIG. 34.

In locating the trunnion it is well to know the several points at which interference is likely to occur and to provide early against such difficulty.

The greatest trouble is generally encountered in locating the break in the floor. If this is to be ahead of the center of rotation, it must be far enough ahead so that a line through the center of rotation at an angle with a perpendicular to the floor line equal to one-half the angle of opening, will intersect the floor at or behind the break. This is readily seen from Fig. 34. If the break in the floor were to be placed at point A (see Fig. 34), the rear end of the moving floor would travel through the circular path AD and come to rest (at full open position) at point D just touching

the fixed floor. If the floor break were to be placed back of point *A* (as at *A'*, Fig. 34), the leaf would obviously foul the fixed floor at some position less than the full open position. If the floor break were to be placed ahead of point *A*, as at point *B*, the leaf would come to rest (at the fully open position) at some point *C* leaving a gap at *C* between fixed and moving floors which, if large enough, would constitute a menace to traffic. It is clear, therefore, that if no other clearance condition limits the location of the floor break, the same should be placed just far enough ahead of point *A* to furnish a working clearance at point *D* between fixed and moving floors when the leaf is fully raised.

There is another limiting clearance condition, however, to wit: The interference of the forward end of the fixed floor with the sway frame

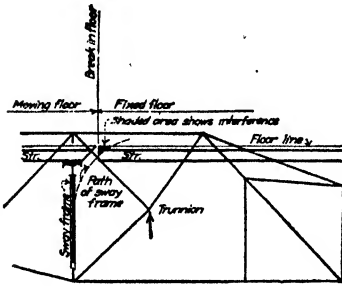

FIG. 35.

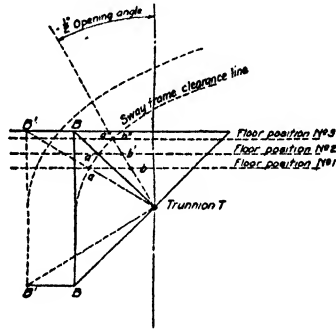

FIG. 36.

between the first panel points of the moving leaf ahead of the trunnion (see Fig. 35).

From an inspection of Figs. 35 and 36 and from the foregoing discussion, it will be readily seen that some very close designing must be done at this point. Consider (Fig. 36) the trunnion definitely located at point *T*. At floor position 1, the break must be placed at, or slightly ahead of point *b*. If the floor is moved to position 2, point *b'* becomes the limiting rearward position of the floor break, etc. It is thus seen that raising the floor operates to throw the limiting position of the floor break forward. On the other hand, the clearance line for the sway frame intersects the floor level at points which move backward as the floor elevation is raised intersecting the line *b-b'* produced at some elevation such as floor position 3 (see Fig. 36). It is, then, obviously impossible to locate the floor above this elevation without having either the sway frame or the moving leaf foul the fixed floor. It becomes necessary, therefore, to move the leaf panel point from *B-B* to some position *B'-B'* so that the clearance line for the sway frame is moved ahead of the trunnion a sufficient distance to provide the necessary clearance. This position increases the required span length (between trunnions) thereby increasing the

amount of metal required in both forward and rear arms, and also the amount of material in the counterweight. This change also obviously operates to increase the size of the pier.

Lowering the floor clearance reduces the available space beneath the fixed floor in which to place the counterweight and also operates to cramp the space necessary for machinery. The foregoing discussion will illus-

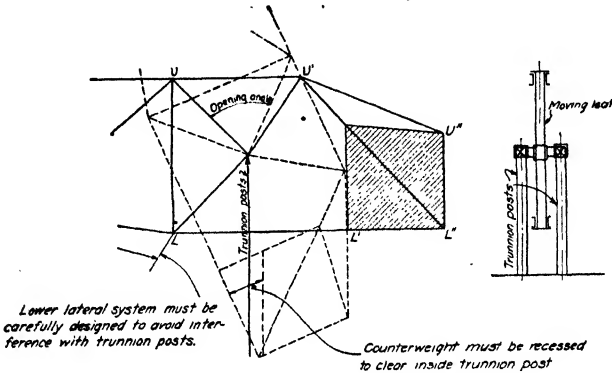

FIG. 37.

trate the difficulty encountered in providing for a true deck truss construction and will also illustrate the importance of careful attention to clearance requirements in order to avoid interference between fixed and moving parts.

Another point of interference is between counterweight and pier in the fully open position. Many times the detail of the counterweight

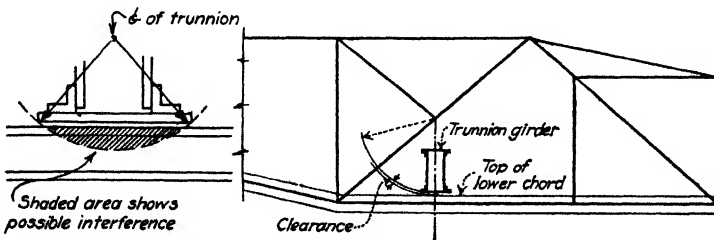

FIG. 38.

must be changed to fit the pier. In the overhead type, this interference is generally between the roadway floor and the counterweight.

Interference must also be guarded against where the lower lateral system approaches the trunnion supports. When the two supports for the ends of a trunnion are carried on columns extending downward into a pit, no lateral system can be used between the trunnion post line and the counterweight which interferes with the trunnion posts (see Fig. 37).

If the trunnion bearings are carried on a cross-girder extending through both trusses, interference must be guarded against where the lower chords pass beneath the girder.¹ At this point, interference not apparent in the closed position of the bridge will develop when the truss is rotated, as will be seen by describing an arc through the extreme edge of the lower flange plates of the girder about the trunnions as a center (see Fig. 38). Care must also be taken to see that the truss members, in rotating, do not foul any of the shafting of the operating machinery. In certain machinery layouts, the main shaft extends through the trusses and operates trains of gears on the piers, these gear trains in turn operating the main pinions. In these types, a portion of the machinery is usually between the trusses on a platform suspended from the fixed floor. This platform must be very carefully laid out in order not to interfere either with the trusses or the counterweight.

All the above questions relating to general clearance requirements, to the position of the various centers of gravity and to the location of trunnions, etc. must be decided and made to correspond before the final design of the counterweight arm can be made and the finished calculations for balance completed.

14. Live Load Stresses.—In the design of the forward or river arm, the exact live load can be used, but in the tentative layout of the counterweight arm only approximate loads can be used until the final form is determined. After a certain shape of counterweight arm is definitely selected, complete and definite stresses may be calculated for this arm as well and the live load stresses are then complete. In single span bascules, the live load stress calculations are no different from those in any other simple span. In double leaf bascules, however, a lock called a *shear lock*, is used at the junction of the two leaves. The purpose of this lock is to make both leaves deflect equally and thus prevent a difference in elevation at the center due to load on one leaf only. The maximum shear passing through this lock will occur when the maximum load is on one leaf with no load on the other. For different members of the bridge, different load groupings will determine the proper shear lock stress to be considered in conjunction with the live load stress. The most convenient way to calculate these stresses is to plot a stress diagram of the leaf with a unit load at the shear lock and then for each possible placing of the live load, determine the pressure on the shear lock. This shear lock pressure (for any given load placement) times the stress in any member due to unit load at the center is clearly the shear lock stress in the given member for the loading considered. This figure is not always to be added to the live load stress, however, as it frequently happens that the shear lock decreases rather than increases the live load stress. An examination of the loading required for any certain stress will soon show

¹ See Art. 6a.

just what values are to be combined to give the maximum. Shear lock stresses and methods for their calculation will be discussed in more detail later.

In those cases where the two leaves are locked for *moment* as well as for shear, the bridge when locked becomes to all intents and purposes a fixed span and should be so analyzed.

When double leaf spans are provided with an anchor arm and an uplift reaction or anchor (to counteract the tendency of the live load to overturn the moving leaf about the forward support), a close adjustment of the finished anchor blocks is needed in order that the anchor may not come into play before the forward support takes its load. If it does, it throws an excessive load on the trunnions and their supports by throwing the entire upward reaction into the trunnions so that the entire live load is supported on an upward reaction at the trunnion and a downward reaction at the anchor. The only other available upward reaction is the forward or live load support, and this support rather than the trunnion, should furnish the necessary upward reaction under full live load (see Fig.

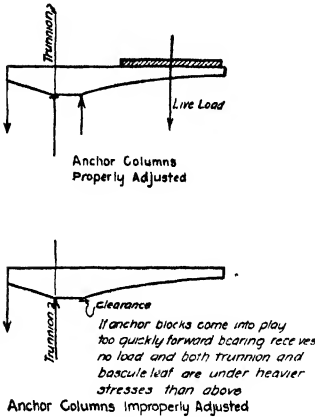

FIG. 39.

39). The anchors, therefore, should never come into play until the center of gravity of the combined live and dead load passes the live load shoes. The anchor columns constitute a downward reaction and since the shear lock cannot be counted upon for upward reaction (on account of the possibility of full live load on the far leaf), the moving leaf, under live load, must be considered as a beam overhanging two supports.

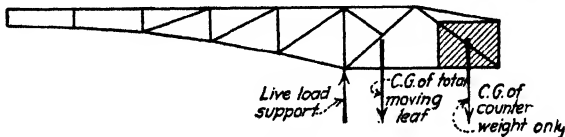

FIG. 40.

Before any live load comes on the moving leaf, the center of gravity of (and, therefore, the whole of) the dead load is centered at the trunnion (see Fig. 40). When the live load comes on the leaf, the center of gravity of the combined live and dead loads moves away from the trunnion toward the forward support and each of these supports (trunnion and forward bearing) then takes its proportion of the total (see Fig. 41). When the live load becomes heavy enough to balance the whole structure

over the forward support, the load on the trunnion becomes zero. When still more live load is added, the anchor bracket comes into play, exerting a downward reaction and the forward support takes all live and dead load and in addition a load equal to the negative reaction on the anchor. All of these cases are susceptible of calculation by simple statics. They all depend, however, on the adjustment of the anchor to such a position that the same begins to take load at the time when the live load just brings the center of gravity of the combined live and dead loads to the forward bearing and thus takes the deflection out of the trunnion supports.

In order to obtain this adjustment, it is necessary to set the anchors so that there is some clearance between the anchor bracket on the moving arm and the anchor on the pier.

It is customary to cushion the anchor with a resilient substance such as white oak blocks. This will compress a certain amount under the maximum uplift which it is called upon to carry.

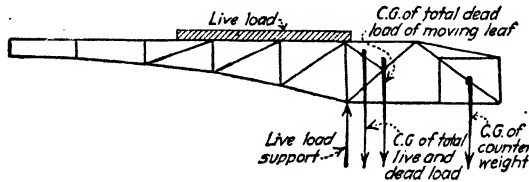

FIG. 41.

When in the unloaded state, there is some deflection in that portion of the counterweight arm between the trunnion and the anchor bracket. There is a greater deflection in this arm when the center of gravity of the combined live and dead loads fall at the live load shoe because in the first case, the counterweight arm is a cantilever supported at the trunnion and in the second case, it is cantilevered clear from the live load shoe. The increased span gives the greater deflection.

As the trunnions carry the full dead load at all times, when there is no live load on the moving leaf, there is considerable deflection in the trunnion supports. During the time that the center of gravity of the dead and live loads is moving from the trunnion forward toward the live load shoe, the load on the trunnion supports is decreasing and the main trunnion girder is rising due to this lessening of the load on the trunnions. This will allow the span to rotate about the live load shoe as a pivot and raise the anchor bracket in proportion to the rise in trunnion supports. The rise in the anchor bracket is equal to the rise in the trunnion (due to a portion of the deflection being taken out of the trunnion girder) multiplied by the ratio of the distance from live load shoe to anchor bracket to the distance from live load shoe to trunnion. In order, then, to find the correct clearance at which to set the anchor blocks, it is necessary to know:

- (1) The difference in the dead load deflection of the anchor arm when supported at the trunnion and when supported at the live load shoe.
- (2) The difference in deflection of the trunnion girder at the trunnion supports under no live load on the span and with full live load on the span.
- (3) The ratio of the distance from the live load shoe to the center of the anchor bracket to the distance from the live load shoe to the center of the trunnion.
- (4) The amount of compression caused in the oak anchor blocks by full live load reaction at the anchor.

The clearance between the anchor bracket and the anchor blocks should be: The rise at the anchor due to the difference in deflection of the trunnion girder under no live load and under full live load; less (a) the difference between the deflection of the counterweight arm with support at live load shoe and with support at the trunnion and (b) the amount by which the oak blocks compress under full live load uplift on the anchors. If this gives a negative result, the oak anchor blocks would be under some compression before any live load came on. This, however, would prevent the *live load shoes* from coming to a firm bearing and would cause a chattering when the live load came on the span. Consequently it is better in such a case to set the anchor blocks to just touch at the instant the live load shoe comes to bearing. In practically all cases, it will be found that a clearance of from $\frac{1}{8}$ to $\frac{3}{8}$ in. is needed between the anchor and the anchor blocks.

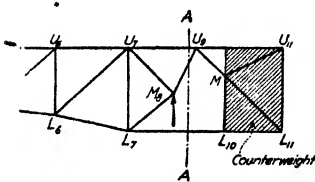

FIG. 42.

15. Dead Load Stresses.—The greatest difference between the dead load stresses in an ordinary framed structure and in a bascule bridge lies in the fact that the bascule must be designed to stand at any angle between

the horizontal and the vertical position. The next point of difference is that the bascule has but one point of support so far as pure dead load is concerned while for live load, it has two or three points of support and for wind load in the open position and for operating stresses, it has two other points of support.

In all these stress calculations, the graphic solution by means of Maxwell diagrams will probably be found to be the simplest and quickest method. It is sometimes necessary to calculate one or two of the stresses analytically and place in the diagram the value thus found, in order to have the complete diagram in one piece. It is perfectly feasible, however, to obtain all the stresses graphically, but in the case of a trunnion support within the truss, such as is illustrated in Fig. 42, the stress in member *L7-L10* cannot be determined directly by working back from

the forward end as there are three unknown forces at both panel points *U7* and *L7*. This stress must either be obtained by taking a section *A-A* and a center of moments at panel point *U9* and calculating the stress in the bottom chord from the loads to the right, or else by constructing a separate Maxwell diagram for the counterweight end and taking the value thus found and substituting it in its proper place in the diagram of the forward end.

Another point to keep in mind in determining the stresses in a bascule truss is that if the dead load stress in the horizontal position (S_H) is of the same sign as in the vertical position (S_V) there will be a dead load stress ($S_{Max.}$) larger than either, occurring at an angle of opening θ , where $\theta = \tan^{-1} \frac{S_V}{S_H}$. The value of this stress is given by the formula $S_{Max.} = \sqrt{S_H^2 + S_V^2}$.¹ This will not affect those members which have a large proportion of live load as compared to dead. The most seriously affected members will be found to be those adjacent to the trunnions.

16. Wind Load Stresses.—There are two main points of difference between wind load stresses and the other stresses in a bascule span. The first is that there are always two points of support, namely, the trunnion and the main operating pinion. The second is that the wind loads can always cause stresses of either sign in any member of the frame. If the wind is from the channel side and puts tension in a certain member, the changing of the wind to the shore side will put compression in that same member. It is very seldom, however, that wind load enters into the final design of any member of the truss proper on account of the provision in most specifications allowing a 25 per cent overstress under wind load.

The amount of wind against which a bascule leaf must operate has long been a mooted question among designers. The governing wind velocity should not be the maximum for the locality but should be the greatest at which it is possible for shipping to use the channel. This is about 40 miles per hr., and is equivalent to a wind load of 5 lb. per sq. ft. It is possible that under some conditions there might occur heavier wind loads while the leaf is up, consequently the following velocities and equivalent pressures are generally used in designing:

Design truss to stand upright under wind load of 15 lb. per sq. ft., or velocity of 69 miles per hr.

Design truss to stand horizontal under wind load of 30 lb. per sq. ft., or velocity of 97 miles per hr.

Design machinery for wind loadings as set forth in chapter of design of operating machinery.

In all the foregoing values, the formula $P = 0.0032 V^2$ has been used for computing the wind pressure.

¹ PAGON, W. WATERS, *Trans. Am. Soc. C. E.*, vol. 76, p. 73.

17. Floor Design.—Stresses in the floor system of a bascule differ from those in an ordinary floor in that provision must be made to support the floor when in the vertical position and to transfer its load to the truss.

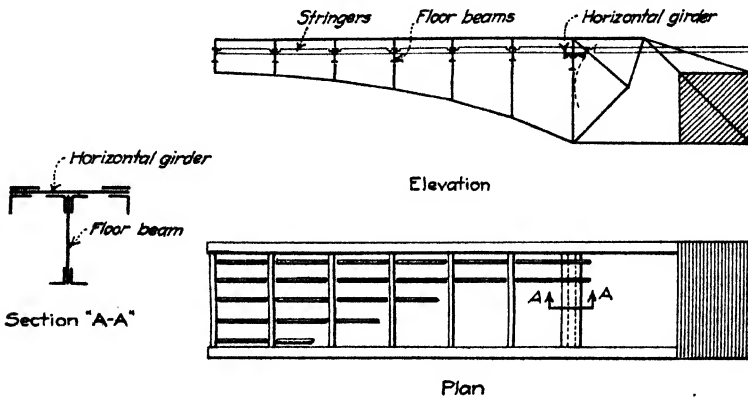

FIG. 43.

This can be accomplished in any one of several ways. The most widely used method at the present time is to provide, at the floor beam nearest the lower end of the open portion, a girder of sufficient strength to carry

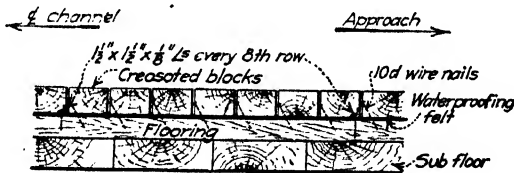

FIG. 44.

the total load of the floor to the trusses at that panel point. When the bridge is down, this girder will be horizontal, lying usually just below the floor and is generally termed the horizontal girder (see Fig. 43). Another

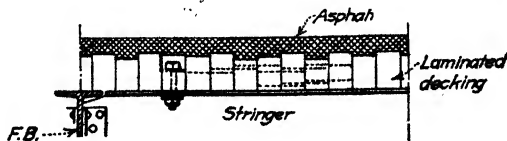

FIG. 45.

method is to make each floor beam strong enough laterally to carry its part of the floor load to the trusses. The stresses occasioned in or by either system are easily calculated and need no comment.

The floor beams are usually built-up sections and the stringers rolled beams or built-up sections framed in between. The stresses in both

of these are easily calculated. The sub-flooring is generally of wood and fastened to the stringers and floor beams by bolts to prevent slipping during the operation of the bridge. The finished floor or paving may be either wood block, an asphaltic compound, or even plank.

When the floor is composed of wood blocks, each piece should be toenailed to the sub-floor and light angles placed at intervals across the roadway to assist in supporting the floor blocks when the leaf is up (see Fig. 44). Where asphaltic compounds are used, care must be taken to see that there is sufficient key to hold the paving of the leaf to the sub-floor. It is nearly always sufficient to build the sub-floor with uneven sizes of flooring and thus provide a key to hold the paving (see Fig. 45).

Some care must be taken to prevent moisture from seeping through the wearing surface of the deck and rotting the sub-floor, as this sub-floor is very hard to repair on account of its inaccessibility. Where the span carries street railway traffic, the problem of supplying the necessary support for the tracks and at the same time, waterproofing the sub-floor, becomes quite complicated. These problems, however, are not limited to bascule construction, but are common to all bridges and therefore, will not be treated here.

18. Erection Features to be Considered in the Design.—In many of the commercial, patented types of bascule spans the point of rotation is so

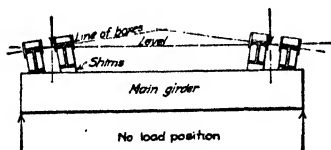

FIG. 46.

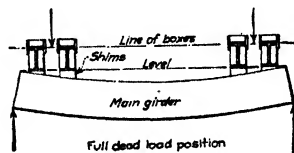

FIG. 47.

arranged that there is an equal deflection of both ends of the main trunnions as the load is applied and removed. In the trunnion girder type of simple trunnion bridge, the deflection of the main girder causes a tipping of the trunnion boxes. Consequently, these boxes must be so placed under no load that they will be level under full dead load (see Figs. 46, 47 and 48). This can be accomplished by either of two methods. First, the boxes may be set on the girder in exact position and bolted firmly in place and the bore then made with a portable boring bar set on an angle. Second, the thickness of shim plates may be calculated sufficient to bring the boxes to line under full dead load and then the boxes carefully machined for height to center of bore from base and for diameter of inside of bushings in order that each pair may be in line. The latter method is theoretically perfect, but practically impossible to obtain. The first method gives a line through the center of each box not parallel to the base of the box. The best method is to calculate the shims, bolt the boxes to the girder with the

calculated shims in place, and then bore the trunnion holes for the bushings with the beveled shims in place.

All the foregoing work should be done in the machine shop and all parts carefully match marked if disassembling is necessary. If not, the girder with the boxes still in place should be moved to the site and placed without disturbing the boxes.

The alignment of the girders should be as nearly perfect as is possible. After the bases for the girders are set and grouted to exact elevation and as near to line as can be, the girder should be placed in approximate position and direct measurements taken with a long tape to establish the distance center to center of girders and then the longitudinal center line of each girder placed exactly at 90 deg. with the center line of the roadway and the distance girder to girder, back-checked. The successful and economical operation of the bridge depends in a large

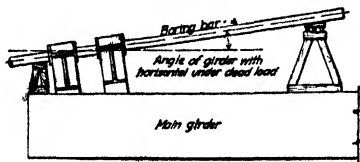

FIG. 48.

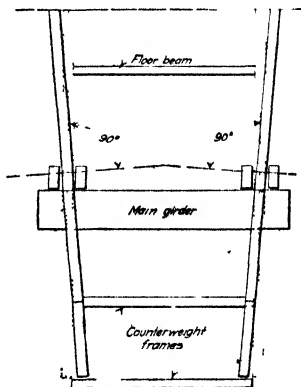

FIG. 49.

measure on the placing of the boxes and the lining up of the main girders.

As the line of the trunnions will not be at right angles to the final plane of the trusses until the full dead load is on the boxes, it is not wise to place part of the steel and attempt to rivet as erection proceeds. Practically the entire steel work should be in place and held by bolts before riveting begins. For instance, if the counterweight ends are placed first and the bridge is being erected in the open position, the distance between trusses at the extreme rear end may be materially shorter than the member which goes between these ends due to the inclination of the trunnion boxes with the horizontal (see Fig. 49). If this piece is riveted in by reaming the holes, it will hold the outer ends too far apart to receive the floor beams. As more load is placed on the girder, however, these trusses become more nearly parallel and finally under full dead load they assume their true line.

After the steel work of both leaves is in place and all riveted except one panel of laterals and one main diagonal for each truss, these being still bolted, the leaves should be lowered and checked for meeting.

The adjustment for the line of the trusses (see Fig. 50) is made by means of the lateral system with the aid of blocks or by rods and turn

buckles. These laterals are unbolted, the trusses pulled into line, and held with the blocks or turn buckles until the laterals are reamed and riveted, thus holding the leaf to the proper meeting laterally. Errors

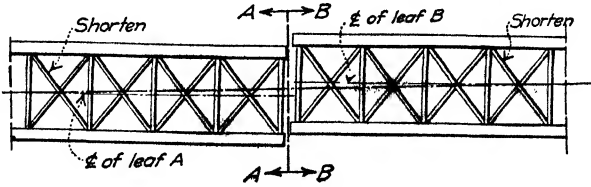

FIG. 50.

in the relative levels of the adjacent leaves, as shown by super-imposing section A-A on section B-B (Fig. 51), are corrected by bringing both floor beams to a level line by means of adjusting the main diagonals which are

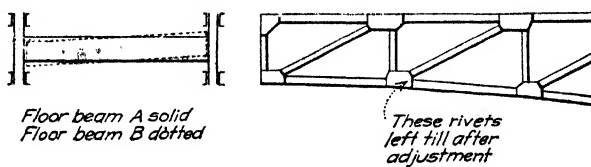

FIG. 51.

not riveted. If the two floor beams are then not at the same elevation, they are brought so by adjusting the shims under the forward bearing or live load shoe. Any slight error in elevation of the adjacent leaves can be corrected in the planking and floor near the ends.

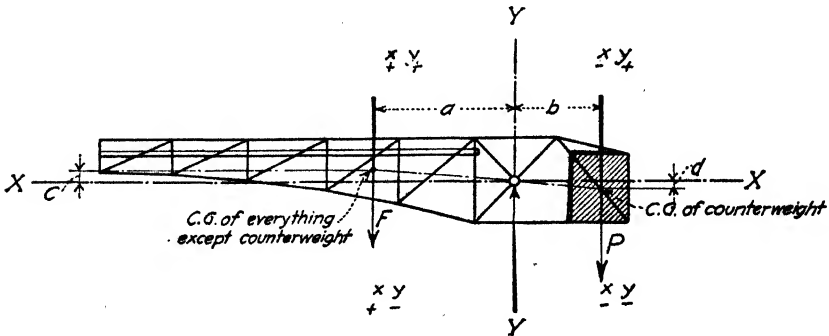

FIG. 52.

The same general method is also true for single leaf bridges when testing and correcting the meeting of the leaf with the far approach.

19. Counterweights.—In the balancing of the span each leaf is considered separately and the procedure is, therefore, the same for single leaf as for double leaf spans.

The amount of counterweight required for balancing any span is susceptible of accurate computation as soon as the individual weights of the different members in the bridge are known. The process of computing the amount of counterweight is a long and painstaking operation. A sample of counterweight calculations is shown on pp. 121 to 123 incl.

After the structure is completely detailed, the weight of each piece and its distance from each of two axes through the center of rotation is carefully calculated and the moment in two directions computed about the center of rotation.

These two axes should be at 90 deg. with each other for convenience and should be taken through the center of rotation. One horizontal and one vertical axis is the most convenient combination to employ. Hori-

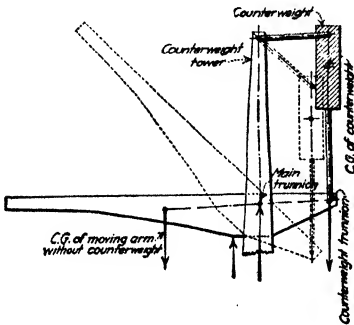

FIG. 53.

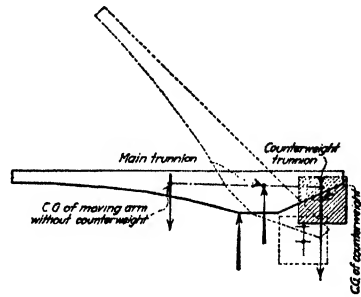

FIG. 54.

zontal moments on the channel side of the center of rotation are usually considered plus and on the counterweight side minus. Lever arms above the center may be considered plus and below minus (see Fig. 52). The calculations for these moments should be close enough to include every rivet head, bolt, etc.—in fact, every item which occurs on the moving portion of the structure.

The total moment of everything except the counterweight itself is computed and then, the distance to the vertical center line of the counterweight being fixed by the dimensions allowed for the counterweight, it is possible to find the amount of counterweight required. With this weight and the vertical moment which it is necessary to balance, it is possible to determine the required position of the center of gravity of the counterweight in the vertical direction, keeping in mind the fact that the line through the center of gravity of the counterweight and through the center of gravity of the rest of the moving span must pass through the center of rotation.

The line from the center of gravity of the counterweight through the trunnion to the center of gravity of the rest of the moving span (every

thing except the counterweight) will be a continuous straight line in the simple trunnion and fixed counterweight types. In the Strauss heel trunnion, overhead counterweight with the parallel link motion and the counterweight rigidly fixed to the counterweight frame (see Fig. 24, p. 25), the above line will be offset from the trunnion at the heel to the trunnion of the counterweight frame, but the two parts of the line connecting the centers will be parallel. In the pivoted counterweight, simple trunnion type, the line does not run to the center of gravity of the counterweight, but to the center of the counterweight pin, as that is the point at which the load is applied. In the case of the pivoted counterweight type, it is not necessary to bring the center of gravity of the counterweight to any fixed point in the vertical line for so long as the total weight is correct, it can be affixed to the hanger at any convenient height and will exert the correct force on the counterweight pin. This is illustrated in Fig. 53 where the overhead counterweight moves vertically and in Fig. 54 where the underneath counterweight is pinned to the counterweight arm. In the Rall vertical lift type, as illustrated in Figs. 25 and 26, p. 26, the line is through the center of the rolling wheel, the counterweight center of gravity and the point of contact of the operating frame and the truss. In the Rall bascule, as illustrated in Fig. 13, p. 16, the line is through the center of the roller, the center of gravity of the counterweight and the center of gravity of the moving leaf.

When the preliminary layout and calculations were made, the size and shape of the counterweight was fixed as closely as possible. At that time, the location with respect to the rest of the truss was decided upon so that the center of gravity of the counterweight would fall at the geometrical center of the mass, thus giving a homogeneous mixture of concrete and reinforcement throughout the whole counterweight. This condition, however, is rarely if ever realized when the final details and counterweight calculations are completed. The desired center of gravity of the counterweight mass is almost certain to vary far enough from the geometrical position of the center of gravity of the counterweight enclosure to require the use of different densities of concrete or galleries and openings in the counterweight. In many cases in actual practice, it has been observed that the final position of the center of gravity is almost always above the geometrical location of the center of the counterweight making it necessary to lighten the bottom of the mass or increase the unit weight of the top portion in order to bring the center of gravity to the required height. This means that the top must be placed higher than was anticipated and in the case of the underneath counterweight type, this is sometimes a serious problem. Consequently a very good rule to follow is to allow room in the original design to vary the vertical location of the counterweight mass either up or down by 5 to 6 per cent of its vertical dimension.

In all discussions and illustrations of bascule spans, it is customary to consider the line which passes through the centers of gravity of the moving leaf and the counterweight as passing through the exact center of the trunnion. In actual practice, however, this condition is seldom obtained or even desired. It is more often desirable to have the center of gravity of the total load on the trunnion in such a position that the motors are working only half of the time of operation.

This allows the center of gravity to be placed in either of four quadrants, as shown in Figs. 55a, b, c, and d. The two last take too much

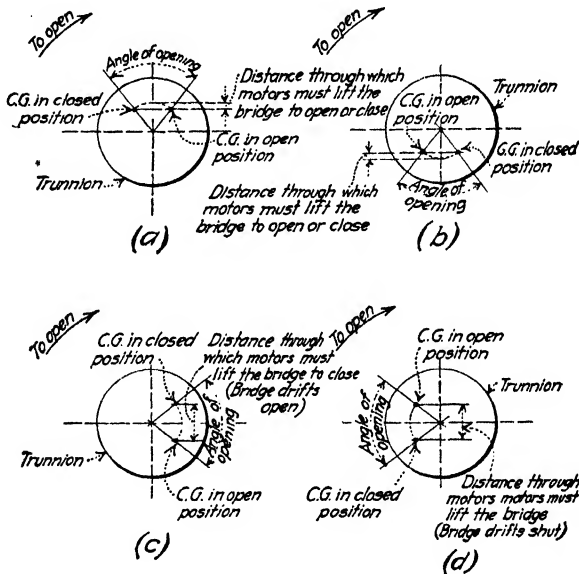

FIG. 55.

power and, moreover, involve an element of danger, and can be dropped without further consideration. In Fig. 55b, the bridge starts open of its own accord if not locked and requires the application of power upon closing until the far end of the leaf is clear into position. Both of these conditions are rather undesirable. The first, because the bridge may become unlocked and swing open of its own accord, and the second, because the application of power to the motors the instant that the shoes come to bearing may cause serious overstress in the machinery, or the truss. The condition illustrated in Fig. 55a is probably the better because the bridge swings closed of its own accord after it is half down and only needs power during the first half of the operation unless working against wind. The operator can, therefore, start the leaf down, shut off the motors and devote his entire attention to the brakes to bring the

leaf to an easy seating with the assurance that, once seated, it will not swing open without the application of power.

The distance at which the center of gravity should be placed from the trunnion is such that it will cause a moment just sufficient to turn the leaf against the friction of the bearings and the free running machinery. This friction is about 15 to 20 per cent of the weight of the moving span. As the friction moment is Wrk (where W = the load on the trunnions, k the friction coefficient of the trunnion in its bearing and r the radius of the trunnion), the distance x ahead of the geometrical center of the trunnion at which it is necessary to place the actual center of gravity (c.g.) is such that $Wx = Wrk$. Therefore, $x = rk$, or (assuming $k = 0.15$) $x = 0.15r$ (see Fig. 56). The distance necessary above the center of the trunnion is the distance to the intersection of the vertical through the center of gravity (c.g.) with a line making an angle $\theta/2$ with the vertical through the center of the trunnion. This insures that the force holding the bridge fully open is the same as the force holding the bridge fully closed and that the same amount of power is required for operation in either direction.

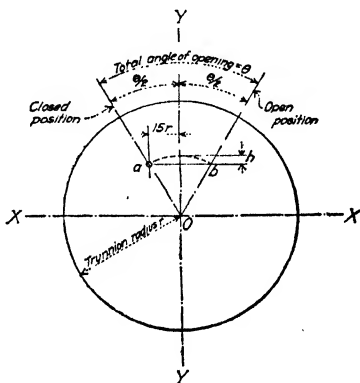

FIG. 56.

The additional power required on account of lifting the span through the distance h (Fig. 56) is very slight and, as the motors are designed to operate against a wind load many times greater than this friction and unbalanced load, they will never be seriously overloaded on this account.

The matter of obtaining a field check on the weight of the counterweight as it is placed is an item of construction engineering, but the provision for seasonal variation in the amount of counterweight needed, should not be overlooked in the design.

Experience has taught that an allowance of 2 to 3 per cent each way from normal should be made. This is done by placing pockets in the counterweights in such positions that small balance blocks may be added or taken away as desired. In the summer, the heat dries out the floor and the counterweight is then too heavy and blocks must be taken out until the desired balance is obtained. In the winter, water, snow, ice and mud accumulate on the span and blocks must be added to counteract the added load. On small bridges, these blocks should be of such size that one man can handle them—say about 75 lb. apiece (see Fig. 57). On large bridges where two men are usually on duty, a block twice this size may be used. They should be detailed with a handle for carrying, and

the handle should be within the outline of the cube so as not to interfere with the stacking of the blocks. In this connection, it is well to see that the balance or adjustment holes are in such a position that the blocks cannot shift during operation, as this might easily cause serious damage.

In computing the amount of concrete required to balance the structure, it is customary to consider first ordinary stone or gravel concrete, using a unit weight of about 142 lb. per cu. ft. in the preliminary

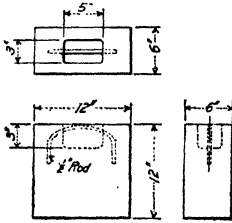

FIG. 57.

calculations for outside dimensions and to provide for a space equivalent to 102 per cent of that actually computed. There is then an allowance of 2 per cent for seasonal variation if the final unit weight is the same as the preliminary. If, however, the final figures require a lighter or a heavier unit weight, or a combination of lighter and heavier, it may be necessary to adopt some of the less common aggregates. Light concretes

can be made from crushed tufa rock, volcanic rock of different kinds, cinders, crushed brick, haydite, waylite, and many other light mineral substances. Heavy concretes can be made by the use of blast furnace slag or by using punchings and small scrap from structural steel shops mixed in with the other aggregate. Following are some notes on test weights of samples of different aggregates which will show the method of obtaining the data sought and will also serve as a rough indication of what unit weight can be obtained by the use of the different aggregates:

Test block	Size	Cubic contents (cu. ft.)	Mix	Gallons water per cu. yd.	Initial weight		Weight at 7 days		Weight at 14 days	
					Total	Unit	Total	Unit	Total	Unit
1a	2' X 2' X 2'	8.00	1:3:6	28.7	1715.0	214.4	1705	213.1
2a	2' X 2' X 2'	8.00	1:3:6	28.7	1690.0	211.3	1685	210.6
3a	2' X 2' X 2'	8.00	1:3:6	28.7	1751.0	218.9	1740	217.5
1b	2' X 2' X 2'	8.0	1:2½:5	1165.0	145.5	1152.5	144.0	1149	143.5
2b	2' X 2' X 2'	8.0	1:2:5	1197.5	149.5	1184.0	148.0	1186	148.5
3b	1.58 X 1.58 X 1.58	4.0	1:2:4¾	23.1 +	600.5	150.0	591.5	148.0	591½	148.0
4b	1.58 X 1.58 X 1.58	4.0	1:2½:4¾	23.1 +	592.5	148.0	589.0	147.5	588	147.0
1c	6.03" φ X 11.30"	0.19	Pit run 1:5	17 lb. 7½ os.	98.2
2c	6.0" φ X 6.78"	0.11	All scoria 1:4:4	10 lb. 2 os.	91.1
3c	6.03" φ X 11.84"	0.195	Sand scoria 1:4:4	21 lb. 1 os.	107.2
4c	6.04" φ X 12.16"	0.20	All scoria 1:3:3	19 lb. 14½ os.	98.8

(a) Slag concrete from Fremont Avenue Bridge, Seattle. (b) Gravel concrete from Youngs Bay Bridge, Astoria. (c) Scoria concrete.

The blocks in series *a* were mixed with blast furnace slag as coarse aggregate, and bank sand as fine aggregate. The slag was crushed to $2\frac{1}{2}$ in. and under.

The blocks in series *b* were mixed with ordinary, $2\frac{1}{2}$ in. and under, river gravel (of a fineness modulus of 7.35) as coarse aggregate and Columbia River sand for fine aggregate.

The blocks in series *c* were mixed with a very light volcanic scoria from Mt. Tabor, near Portland, Ore. The material was crushed, screened and reportioned in the last three cases and in the first, was used as bank-run—that is, without screening and reportioning after crushing. As this material was very soft, the unit compressive strength of the blocks was very low. If this kind of material were used, it would require complete protection by means of a closed counterweight box.

It is, of course, possible to use other materials than concrete for making counterweights. Cast iron is the medium most frequently resorted to outside of concrete. This material will generally cost in the neighborhood of from 2 to 3 cts. per lb. laid down on the work. Concrete of gravel or crushed rock weighs very close to 4,000 lb. per cu. yd. and, at a price of from \$12 to \$20 per cu. yd., would cost from 0.3 to 0.5 cts. per lb. which shows that the concrete has a decided advantage whenever there is room to use it. As the available space decreases, it is always best to use as much of the cheap material as possible and make up the difference with the more expensive. Scrap steel rails weigh 480 lb. per cu. ft. and can usually be bought at about the price of cast iron. One point in their favor is that they make excellent material for tying the concrete of the counterweight together.

In selecting the counterweight material, attention should be given to the fact that where the counterweight swings below the water and needs a pit, and, where for any reason a reduction in the size of the counterweight means a reduction in the overall dimensions of the piers, it may be advisable to use a heavy unit weight and save more on piers than is spent on expensive counterweight material.

20. Design Specifications Peculiar to Basculas.—The points in which the design specifications for a bascule span should differ from those for any fixed structure are in regard to the operation conditions. Such points as alternate and combined stresses, slenderness ratios, the use of net and gross sections, minimum requirements for thickness of metal, size of angles, rivets through fillers, sub-punching and reaming, and the like, are the same as for a fixed structure. In addition to these usual specifications, there should be provisions made for:

- (1) Impact allowance of 40 per cent at the anchorage, which will increase the design stress in the anchor columns and in the counterweight arm.
- (2) A clause providing that the anchor column should engage a mass of masonry weighing not less than twice the maximum computed uplift.

(3) Wind load in any direction when the leaf is raised. This is usually taken at 15 lb. per sq. ft. over the projected area.

(4) Stresses caused by center lock on double leaf designs. These are determined by the use of an empirical formula which gives the amount of shear assumed to be transferred from the loaded to the unloaded leaf by the center lock in those designs which have provision for shear and not for moment at the center. This formula is as follows:

$$S = \frac{P}{4} \left(\frac{A}{L} \right)^2 \left(3 - \frac{A}{L} \right)$$

where

S = shear carried by center lock.

P = any concentrated load.

A = distance of P from forward bearing.

L = length of river arm from forward bearing to floor beam at center of channel.

When the overhanging leaf is a truss, P becomes the panel load, A the number of panels between P and the forward bearing of the loaded truss, and L the number of panels in the overhanging arm. The computations are then quite simple.

(5) Unless hydraulic or pneumatic cushions are to be employed, oak or other suitable material should be used for bumping blocks at the upper and lower limits of travel to deaden the shock of contact when the leaf is fully opened or closed.

(6) An allowance of 20 per cent of the dead load stresses should be added when opening to provide for vibration stresses. This will probably govern the design in only a very few members, but should not be neglected.

FOUNDATIONS FOR BASCULE SPANS

21. Conditions Peculiar to Bascule Spans.—There are several points in which the foundation design for a bascule span differs from that of an ordinary bridge. These differences are caused by the shifting nature of the load. When the foundation for the moving leaf consists of a forward pier and a rear pier, not connected at the base, the only effect of the changing position of the loads is to increase the direct pressure on one pier and decrease it on the other. If, however, the foundation is a unit as in Fig. 19, p. 20, the shifting of the load decreases the pressure at one face of the footing and increases it at the other, and the result is a rocking action that is different from the straight vertical action when the forward and rear piers are not connected.

In those structures having a fixed center of rotation, such as the Chicago type simple trunnion and the various types of Strauss bridges, this shifting action occurs only under live load. In the rolling and semi-

rolling lifts, such as the Scherzer and Rall types, the shifting action occurs under dead load when opening as well as under live load.

In considering the shifting action due to the live load, it is unnecessary to consider the internal arrangement of the piers or superstructure. The only data required are:

- (1) The total weight and center of gravity of the pier and superstructure.
- (2) The area and shape of the base of the pier.
- (3) The total weights and centers of gravity of the various live loads which are placed on the roadway to obtain maximum conditions of loading.

The shifting of pressure under live load occurs, in general, with all double leaf bascules whether they have a fixed or moving center of rotation. In single leaf bascules, the passage of the live load merely increases or decreases the vertical load on the support and, as the truss is supported at both ends, does not cause a tipping action as in the case of a double leaf structure which has a cantilever arm.

In considering the action of the dead load during operation, it is readily realized that with a fixed center of rotation the point of application of the dead load of the superstructure remains fixed and that therefore, the resultant dead load of the pier and superstructure does not move. In the types which have a moving center of rotation, the dead load of the superstructure is always applied at the point of contact of the roller. The maximum dead load footing pressure at the forward footing or edge of the unit pier occurs, therefore, with the span closed and at the rear footing or edge of the pier with the span open.

The consideration of wind load often gives the maximum design load on the footing especially when the center of area of the raised leaf is at a considerable distance above the bottom of the footing.

The items to compute in finding the maximum footing loads are then as follows (keeping in mind that the "toe pressure" on a unit pier corresponds to the "unit load on the forward pier" in a design having two piers per leaf, and that "heel pressure" on a unit pier corresponds to the "unit load on the rear pier" in the two pier design):

Dead Loads

- (1) Toe pressure and heel pressure, leaf down.
- (2) Toe pressure and heel pressure, leaf up.

Live Load

- (3) Toe pressure and heel pressure, full live load on approach and fixed portion, no live load on moving leaf.
- (4) Toe pressure and heel pressure, full live load on moving leaf, no live load on approach or fixed portion.
- (5) Toe pressure and heel pressure, full live load on approaches, fixed span and moving leaf.

Wind Load (Leaf raised to full open)

(6) Toe pressure and heel pressure with wind from river side.

(7) Toe pressure and heel pressure with wind from approach side.

The combinations most likely to give maximum loads are (2), (3) and (6) for maximum heel pressure and (1) and (4), or (2) and (7) for maximum toe pressure. Case (5) may give a higher load under the center portion of the unit pier than either of the above combinations, or may give a higher load on both piers of the two pier design than any of the above combinations, although the last condition is hardly probable.

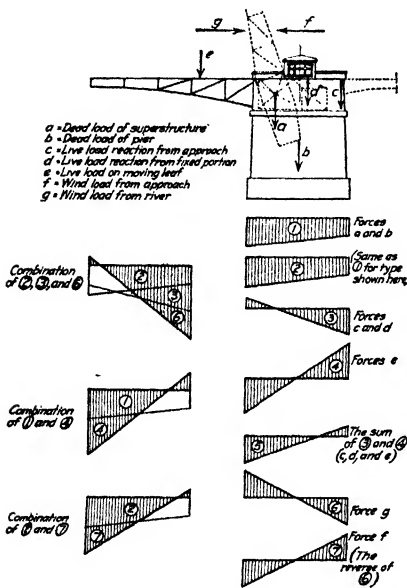

Fig. 58.

Figure 58 illustrates the pressure diagrams on the unit pier for the above seven conditions together with the various combinations just mentioned.

The difference between the results here obtained and what would apply to a rolling lift would be due to the fact that Diagrams 1 and 2 would be materially different. Diagram 1 would show maximum pressure at the toe as in the figure shown, while Diagram 2 would very likely be just the reverse, showing a maximum pressure at the heel and thereby increasing the total heel load in the combinations of 2, 3 and 6. This means that the churning or rocking action would be greater with a rolling lift type than with a fixed trunnion type. If, however, these

maximum pressures are well within the safe load on the foundation, there is little danger of serious settlement from this action. It may perhaps be easier to proportion a footing in a restricted area for the fixed trunnion type than for the rolling type if the foundation is so soft as to require the extensive use of piling to carry the loading.

When the unit pier is composed of a four walled box set on a tremie concrete seal which covers the whole area of the pier base, it is not possible to vary the unit foundation pressure very greatly. Varying pile spacing can sometimes be employed to obtain the proper distribution of loads, but on solid foundations, the only thing which need be certainly determined is that the maximum pressures are well within allowable limits. However, the tremie seal is usually confined to soft bottoms where piling must be used and in that case varying the pile spacing takes care of the varying loads.

When foundations are sufficiently solid to permit of high bearing pressures, the unit pier can be most economically designed by using a trapezoidal footing in order to have a wide base where the pressure is heaviest and a narrow base where the pressure is lightest, thereby keeping the maximum soil pressure nearly uniform throughout the whole structure and assuring an even settlement if there is any tendency in that direction.

This type was employed in the piers of the Eastlake Avenue Bridge, Seattle, Wash., and is illustrated in Fig. 59.

Piers which have no churning action and where no watertight pit need be provided, present comparatively few difficulties. For that reason, they will not be discussed further. There are, however, several points in connection with the design and construction of watertight counterweight pits and of piers on soft bottoms to accommodate such pits, that may well

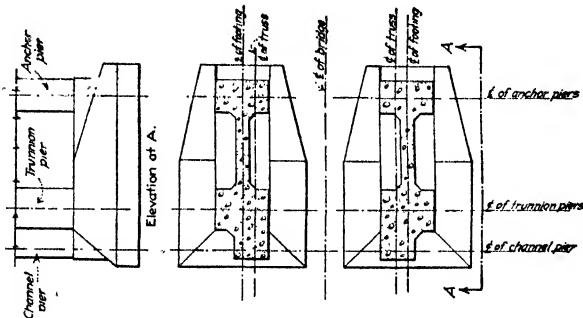

FIG. 59.

be discussed more fully. The following discussion will, therefore, be confined to a pier to support one leaf of a double leaf trunnion bascule. The counterweight is hung under the approach roadway. The break between the fixed and moving floor is several feet ahead of the trunnion and the counterweight arm is so long as to require the use of a watertight pit. The foundation material is of such a nature that piles are necessary.

The best general method to follow in the design of such a pier is to determine as closely as possible by preliminary sketches and calculations the size of the pier outlines. The location of the forward, main and rear (or anchor) columns will be fixed by the dimensions of the moving leaf. The height of the pier will be determined by the distance from the roadway grade to foundation elevation. The distance from side to side of the pier will be governed by the width of the roadway and the question of number and width of sidewalks together with the desired location of machinery and operating houses. The actual size of the cross-section of the various columns will be governed more by considerations of proportion than by the actual loads coming upon them. The main columns must support the grillages under the girder which carries the trunnion

bearings. The main girder is braced to this grillage to withstand the overturning effect due to wind on the upraised leaf. The grillage must, therefore, be long enough to distribute the overturning moment to the column without overstressing the masonry. This will generally result in a main column which is larger in the direction of the roadway than would be necessary for the direct load.

If the pier is high on account of deep water or because of a roadway far above water level, it will be advisable to have one or more sets of heavy horizontal beams running around the pier to brace the columns and act as supports and stiffeners for the floor and walls of the counterweight pit.

The size and spacing of these columns and the depth of the pit will give the designer a basis for making a close estimate of the dead weight on the piling.

As was mentioned before, a bottom so soft as to require piling will very likely be too soft to stand in open excavation and will, therefore, require a tremie concrete seal before the cofferdam can be pumped out. The depth of concrete required in this seal is such that the weight of concrete just offsets the head of water on the bottom of the seal.

This will be (with a 145-lb. concrete) $\frac{62.5h}{145}$ where h is the static head of water on the bottom of the seal. The ratio of 62.5: 145 is approximately 0.43. This thickness is reduced by some designers on account of the holding power of the pile heads around which the tremie seal is placed. This holding power is usually taken at about 100 lb. per sq. ft. of area of pile which is surrounded by concrete, not including the cross-sectional area of the top surface of the pile. Care must be taken to see that sufficient penetration will be secured to allow this bond to be effective. Short piles might pull out under a less uplift than would be occasioned by the above bond value. The required depth of the seal cannot be lessened from a consideration of low porosity of foundation material because if the foundation is not porous, no seal is required and if it is porous at all, the slightest leak under the footing will, in a short time, put the full static head on the seal.

With the ordinary pier, the trial outside dimensions for the seal should be just sufficient to allow easy working room inside the caisson and outside the pier forms. This size will usually be found sufficient to cover the required number of piles. If necessary, a slight extension of the forward edge to accommodate an extra row of piling can be added after the preliminary calculations are made.

The bottom of the concrete should be deep enough to prevent all possibility of scour undermining the seal and exposing the piling. In ordinary navigable waters, this is usually 6 to 10 ft. below the bed of the stream.

With the preliminary sketches made from the above information, the seven conditions of loading mentioned at the beginning of this article

may be calculated and the proper combinations made to determine the maximum pressures at the toe and heel of the footing. This pressure must be taken care of by the use of piling and sufficient piles must be placed under the pier to take the entire load of the pier and truss. The buoyancy of the concrete may be deducted, but no allowance should be made for the water displaced by the volume of the inside of the counterweight pit as it is quite possible that the pit may at sometime become full of water. The fact that the pier rests on the piles when the cofferdam is pumped out is not an argument against considering buoyancy because the dead weight of the moving leaf is seldom ever added until after the caisson is either flooded or removed entirely.

22. General Description of a Typical Bascule Pier.—Whether the footing course is a tremie seal or two trapezoidal footings each carrying

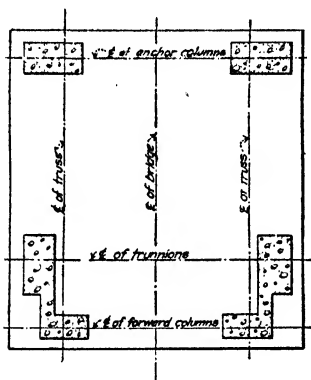

FIG. 60.

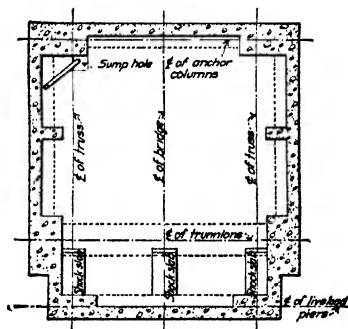

FIG. 61.

one forward column, one main column and one anchor column, the construction of the balance of the pier is the same above the top of the footing.

Figure 60 represents a plan of a unit pier taken just above the top of the footing and several feet below the bottom of the watertight counterweight pit. It shows the three columns on each side of the roadway and the general outline of the structure. Figure 61 is another plan of the same pier taken just above the bottom of the counterweight pit and shows the walls of the pit, the beams under and around the pier sides, and the concrete blocks cast on the floor of the pit to receive the oak bumping blocks which limit the travel of the leaf when opening. Figure 62 is a cross-section of the pit on the center line of the roadway and shows the relation of the main girder to the truss and shows also the location of the platform which carries the operating machinery.

At the rear end may be seen the steel anchor columns which engage the brackets at the rear end of the truss and provide the necessary reaction

against uplift under full live load on the overhanging arm. At the forward side may be seen the live load shoes which rest on the forward column and take the bearing of the live load from the truss. The relation of the fixed floor to the moving floor is also shown, as well as the method of supporting the fixed floor on the main trunnion girder. The general outline of the pit is also apparent as is the method of bracing the columns with the large horizontal beams. The slope shown on the top of the tremie seal is such as is to be expected when the seal is poured from the center and allowed to flow to the sides of its own accord. This slope is variously found to be from 1 in 6 to 1 in 4. Allowance in design should, of course, be made to care for whatever slope occurs and the top should be levelled off for the columns after the cofferdam is unwatered. At the rear of the pier is seen the platform by which access is had to the anchor columns for the adjustment of the anchor blocks.

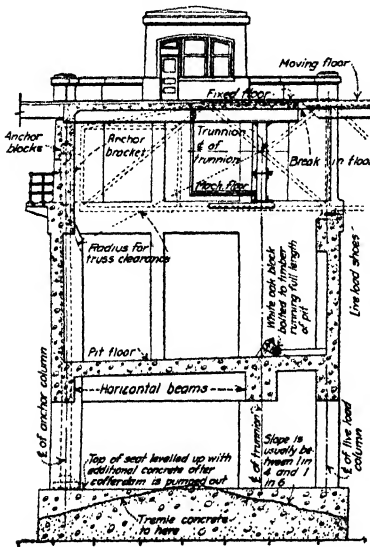

FIG. 62.

23. Counterweight Pits.—In the design of the counterweight pit, the first requirement to be met is that of watertightness. This is accomplished by making the walls extra thick and of high grade and dense concrete or sometimes by placing an outer surface of mortar at the same time the inner portion of the wall is placed. Neither method should ever be used except under the most rigid inspection. One bad gravel pocket in a pit wall or floor is a most serious condition. When designing such a pit, reinforcement should be provided

against outward as well as inward pressure as it may be desirable to test the pit for watertightness by filling it with water before the cofferdam is taken out. This allows the small leaky spots to be detected, marked and repaired from the outside before the water is let in around the pier and oftentimes saves an otherwise poor job. If the waterproofing consists of a layer of mortar cast with the walls, reinforcement must be so arranged as to permit the use of baffle boards. These are usually made of structural plate with distance pieces to maintain them at the required distance from the outside face of the forms. The ordinary concrete is placed in the main part of the wall and the mortar placed behind the baffle board at the same time. The baffles are drawn up as the concreting progresses and the forms thoroughly tamped, rodded and pounded to assure a good, thorough bond between the concrete and the mortar.

This method of waterproofing is very exacting and requires infinite pains and constant supervision. The results usually justify the expense, however, as the pits where this method has been used have been completely dry when once pumped out. The customary thickness for this type of mortar facing is 6 in. A less thickness might work very nicely, but would be too difficult to obtain with accuracy. Pit walls should in general be as thick as the static head of water would call for, but never less than 18 in. In the event of slight leaks, it is reasonable to suppose that in time enough silt and minute vegetation will settle in the crack or leak to close it.

A pump and motor are always placed in the waterproof counterweight pits to drain them of any water that may leak through the walls or drip into the pit from the roadway above. These pumps and motors need not be large, in fact, a 2-in. centrifugal pump with a 3-h.p. motor is ample for almost any pit where the lift is less than 22 ft. Above this, the size of the pump and motor should be increased slightly and the pump placed in the pit and attached to the motor by means of a vertical shaft in order to keep the motor above water and yet obtain the full efficiency of the pump.

In all bascule piers, it is necessary to have a set of buffers to catch the moving leaf at the limits of travel and cushion the jar caused by bringing the leaf to a sudden stop. White oak is one of the best and most easily obtained materials from which to make the buffer blocks. These blocks are generally located in the anchor columns for stopping the bridge in the closed position and in the bottom of the pit between the main columns for stopping the bridge in the open position. In determining the location of the lower buffers, great care must be taken to so place and reinforce their supports that the shocks and impacts are transferred to the floor and columns in a manner that will not crack the pier walls. A pier wall once cracked would mean the driving and unwatering of a cofferdam to repair the damage and might require the entire reconstruction of the waterproof pit. It is customary to locate the bumper blocks on the floor of the pit against long ridges of concrete cast integral with the pit floor immediately above the heavy beam between the main trunnion columns and to anchor these ridges to the rest of the floor with plenty of reinforcing to insure them against cracking away on account of shrinkage or shocks. Across the face of these ridges is placed a heavy fir timber extending from side to side of the pier. The white oak blocks are bolted to this fir timber and can thus be removed and renewed should they become battered or decayed.

Hydraulic and pneumatic shock absorbers have also been used with considerable success for work of this kind.

24. Anchor Columns.—The anchor columns are a very important part of the pier and next to the main trunnion girder are probably the

most difficult part of the structure to place and maintain in a correct position during the placing of the concrete. They are always the first part of the structural steel to be placed and their bases must be set to exact grade and line long before the concrete is brought up to the height necessary for placing the main trunnion girder. These columns must be exactly on the center lines of the trusses, as their location fixes and determines the line of each truss across the moving leaves. They are usually made of four angles with a diaphragm, the legs of the angles

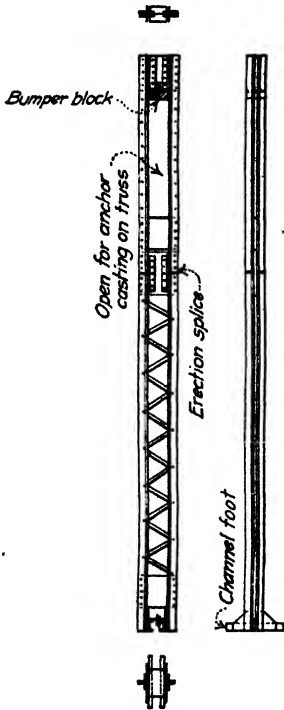

FIG. 63.

being turned away from each other in order to permit of the detailing of a rigid seat against which to land the anchor brackets on the moving leaf. The bottom end of these columns should have a spread base to assist in engaging the desired amount of masonry as anchorage against uplift. The top extremity has a diaphragm of sufficient length to develop the strength of the column in tension and is stiffened by numerous vertical angles riveted to the main column angles and to the diaphragm. These stiffeners and the diaphragm in turn carry a horizontal bearing plate at their lower edge. This plate is provided with holes through which to bolt the shock blocks used to deaden the impact of quick closing. Hand holes should be provided through which to reach and remove the bolts holding these bumper blocks. These hand holes can usually be placed in the diaphragm above the block. The tops of the columns are up under the floor and therefore, far above the base. It is very difficult, therefore, to maintain correct alignment during the placing of the anchor column concrete and especially

hard to prevent the columns from twisting about the vertical axis. A general detail of an anchor column is shown in Fig. 63.

25. Tremie Seal.—The easiest foundation to construct is one which can be handled in the dry without the use of extensive cofferdams. This condition is rarely encountered in bascule bridge construction principally on account of the fact that in order to need a bascule span, the water must be navigable and navigable water is usually fairly deep.

There are several types of cofferdams and caissons in common use for placing foundations under difficult conditions.

Where the area of each pier is small in relation to the depth and where the small section can be carried above high water, the steel shell and air

lock method works very nicely, but when the area is large or when the whole area of the pier must be floored below low water, the tremie seal, in general, has proven the best method of preparing the cofferdam for unwatering. The only reason for sealing the bottom of the cofferdam is to allow it to be pumped out without its leaking. Because this type of foundation construction has been used so often with pile footings, it is sometimes rather hard to dissociate the idea of a tremie seal from that of piling in the base. However, if a pier is to be founded on coarse gravel and boulders or very seamy but hard rock, it would be obviously unnecessary and impossible to drive piling, but also impossible to pump out a plain caisson. Such a case calls for a tremie seal just as truly as does a pier which is to be founded on silt or other soft material, requiring long piling at minimum spacing to carry the load. Both these cases will develop full static head on the bottom of the seal. In all ordinary depths of water, as has just been stated, the tremie seal will give the best results. As the depth increases above 50 or 60 ft., the amount of concrete required for the seal becomes excessive and other schemes must be investigated.

The depth of concrete required in a tremie seal is the amount required to counteract the static head of water on the bottom of the seal. The depth of such a mass of concrete will be to the static head as the unit weight of the water is to the unit weight of the concrete; or, for all ordinary cases, $d = \frac{62.5h}{145} = 0.43h$, where d = depth of concrete and h = head of water. There are several factors affecting the selection of the depth of seal required which are outside the foregoing purely theoretical consideration. First, the pile heads (if piles are used) will have a bond in the concrete which has been variously estimated at 50 to 150 lb. per sq. ft. of pile surface in the concrete. Second, the caisson, if excavated from within, and forced down through the soft strata until the cutting edge is at the bottom of the footing will have a decided friction upon the sides of the excavation. Third, it is very easy to build boxes around the sides of the caisson and fill them with stone or gravel to hold down the caisson against the uplift. The second and third cases can be used to assist in holding against the static head only when the inside of the caisson is so arranged that the seal cannot lift without lifting the whole caisson. The bond on the pile heads can be used at 100 lb. per sq. ft. of pile surface (excepting, of course, the top surface of the pile). These three factors added together may generally be counted upon to reduce the depth of the seal to 75 per cent or even 60 per cent of that theoretically required to balance the static head. When a pier is to be founded on a solid but porous bottom and when practically no excavation is needed, it is necessary to send a diver down to stop up the small gaps and openings around the bottom of the caisson between its lower edge and the foundation surface. Otherwise, the cement from the concrete is washed

away and the resulting gravel pocket robs the pier of that much footing area. These holes may be stopped with sacks of sand or with wooden lagging, the former for small openings and the latter for the larger openings with perhaps a combination of the two for some cases. The same procedure must also be followed when the caisson is set into a previously dredged area sufficiently large to allow the placing without further excavation. This case is often encountered where there is a large dredge available to make the excavation and no equipment reasonably available with which to dredge out the cofferdam from the inside. An example of such a case is where a bridge is to be built over a waterway just being dredged through a formerly shallow lake. The dredge which is working on the channel can swing over and take out the pier excavation at a very low cost as compared with the usual cost of pier excavation. A combination of the two methods is sometimes advisable where the natural contour of the bottom is so rough as to be likely to warp the caisson out of shape should it seat hard on one corner before bottom was reached on the others. In such a case, the bottom is leveled off, the caisson sunk and the rest of the material dredged from the inside, the caisson being forced down as the dredging proceeds. The determining factor between the above methods will be the relative cost of the various ways of obtaining the same result. If equipment for inside dredging is on hand, and payment is to be made only on material inside the neat lines on the pier (as is usually the case), the price for first dredging a large hole would have to be exceedingly low in order to command consideration. Again if a dredge were in the neighborhood and would submit a fair price, it might not pay the contractor to procure inside dredging equipment.

A careful study of these questions will usually determine without much doubt which is the best method to pursue.

In determining the amount of excavation to make, it must be remembered that, if piles are to be driven, the level of the bottom of the excavation inside the cofferdams will be raised materially during the process of driving the piles. This is more noticeable with jetted piles than with those not jetted. It is also more noticeable when the outside piling are driven first (no jet being used). The volume of such material forced upward by the pile driving is, with jetted piles, about 75 per cent of the volume of the piles in the ground and, with driven piles, about 40 or 50 per cent of the volume of the piles in the ground.

For instance, with a pile spacing of 3 ft. each pile has a tributary area of 9 sq. ft. Using jetted piles with an average diameter of $13\frac{1}{2}$ in., the volume of the pile is 1 cu. ft. per ft. of length. With the bottom of the pile at -90 and the bottom of the concrete at -36, there is a penetration of 54 ft. or a pile volume of 54 cu. ft. This on an area of 9 sq. ft. would give a depth of 6 ft. The actual pile swell from an observed case having the above figures was $4\frac{1}{2}$ ft., or 75 per cent of the actual

volume of the pile in the ground. The difference between the behavior of jetted and driven piles is due to the fact that practically all material from the jetted hole is washed to the top while the driven piles force only a portion of the material up, compacting the rest. To allow for the above condition, it is customary to excavate below the desired depth a sufficient distance to allow the pile swell to bring the earth back up to the desired level, thus eliminating any subsequent dredging in and among the pile heads. This, of course, presupposes a fairly accurate knowledge of the required penetration and indeed no important structure should be started until thorough investigation has been made into the foundation conditions which surround the site.

In considering the advisability of sheet pile *vs.* crib, the question is again one of cost. As a usual premise, it may be stated that the deeper the water, the less showing the sheet piling can make. Steel sheet piling are much more satisfactory than wood, but in most localities wood is more plentiful and, therefore, much cheaper. Sheet piling can compete with timber crib work in ordinary water up to 30 ft. deep, but for greater depths than this, the inside bracing in sheet pile cofferdams becomes increasingly difficult and the cost mounts up in proportion, making it advisable to adopt the more complicated process of building and sinking cribs or caissons. When the cost of building the two types is very nearly equal, the sheet pile will probably show up better in moderately stiff excavation, and the crib will probably show up to better advantage in very soft or silty bottoms. This last is because of the fact that it is safer in stiff soil to excavate inside well driven sheet piling than inside an open caisson, which of necessity is not as watertight around the outside between the soil and the wood. In very soft or silty foundations, the water cannot be pumped out on account of the porosity of the bottom, therefore, it is easier to sink a crib by dredging inside than to drive sheet piling which have to be braced as dredging out progresses and which will not in general have a bottom support sufficiently stiff to support the lower ends.

26. Operator's Houses.—The operating houses of a bascule span must, of necessity, be placed on the fixed portion and therein they differ from those on a swing span or a vertical lift bridge. Moreover, they cannot be placed above the roadway on its center line because if they were the upturned leaf would shut off the operator's view of the channel. Neither can they be placed in the face of the pier below the deck because the operator must watch the roadway. The only available space is at one side of the roadway close to the front of the pier and either at or above the level of the roadway.

This makes it desirable that four houses be built if the structure is to be an ornamental one. If it is merely for utilitarian purposes and esthetics are neglected, one or two operating houses can generally be made to

serve the purpose. If four are built to give balance to the design, one may be used as the operating house proper, one or two may be used as quarters for the operator and the others used to store the equipment and supplies needed about the bridge. When quarters are provided, they should be roomy, well ventilated and lend themselves easily to frequent and thorough cleansing. The inside finish and plaster should be of the very best and capable of standing years of very severe usage. The main

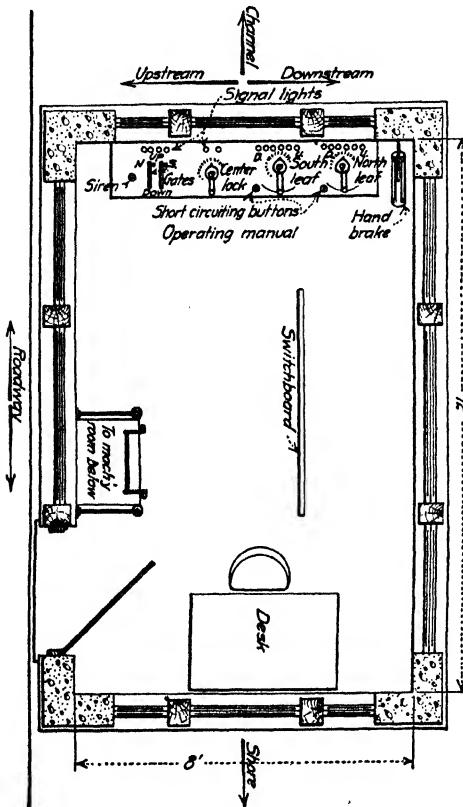

FIG. 64.

operating house will have to contain the operating manual, hand brake, switchboard, desk and chairs, gages, current indicators and the like. In short, everything necessary to the proper operation of the bridge should be placed in this one room and so arranged as not to obstruct the view of the operator from the channel or the roadway. On all ordinary electrically operated bridges, this usually requires a floor area of about 8×12 ft. as a minimum; 10×14 ft. is better, but above that there is usually too much distance between the different pieces of apparatus for efficient operation.

The operating manual is located in front of the window which looks across the channel. The switchboard may be edgewise behind the operator as he stands at the manual and should be out of his lines of sight up and down the

channel and down the roadway. A very good arrangement is shown in Fig. 64. The hand brake should be near his right side and so placed that he need not be against the switchboard when using it. Directly over the operating manual may be the pull cord for sounding the fog bell. The ammeters and voltmeters may be on the switchboard as the operator does not care to watch them during the raising of the leaf. They can be read by an observer when any series of tests are to be made. It should be needless to say that all available light should be secured and to this end, the house should consist of corner posts

and full glass walls from the window sill height to the ceiling. Heat must always be provided, and where electric heat is not available, coal, wood, gas or oil may be used. When the bridge is electrically operated, there is oftentimes a minimum charge for power on which the amount of current consumed by an electric stove has very little effect. For this reason, electric heat is many times the cheapest as well as the most desirable from the standpoint of cleanliness. Heat should also be provided in the living quarters as well as plumbing for toilets and wash basins. These are sometimes placed down inside the pier where a large unit concrete pier is used. The soil pipe from such fixtures should be carried down to 1 ft. below water level and all fixtures should be vented with pipes through the roof. Running water can usually be taken from the fire-protection system. If there is no such protection, steps should be taken to see that there is adequate means provided to keep water on hand at all times.

27. Pier Fenders.—While pier fenders are not essential to the operation of bascules, they are necessary in narrow channels as safeguards both to the piers and to navigation. In fact, their value is so universally recognized in such locations that the War Department in granting permission to construct bridges across navigable waters of the United States requires that the plans of the fenders be shown along with the rest of the bridge. They should have wing walls extending up and down stream and back toward the shore, thus preventing shipping from coming into contact with the piers and interfering with the operation of the movable span. In order that boats coming into collision with the fenders, may be guided into the channel without disastrous results, it is customary to make the wing walls at about 45 deg. with the center line of the channel. The usual construction is timber piling from 4 to 8 ft. on centers with a heavy timber along the top and the face toward the channel sheathed with lighter plank so placed that there are openings between the sheathing or waling pieces for the passage of water without damage to the facing. The piles must have resiliency enough to give under the impact of shipping and the top sheer strake and the waling must be strong enough to transmit the load to the piles without breaking and thus allowing the boat to crash through, wreck the fender, and reach the bridge proper.

Practically all large channels today have a minimum depth of water of 30 ft. Some have more. This 30 ft. represents the unsupported length of the fender piles. They should therefore be quite heavy and there should also be a seven or nine pile dolphin at each corner of the fender and at each intersection of pier protection and wing fender. Piles approximately 16 to 18 in. at the butt should be used and driven to sufficient penetration to cause them to break off rather than pull out under a horizontal load. The sheer strake along the top should be not less than 10 × 14 in. bolted to every pile head and to the waling piece

against its lower edge. The waling should be 4×12 with joints broken on every third or fourth pile so that no two adjacent waling pieces will be jointed on the same pile. They should be bolted to not less than two piles in each dolphin with which they come in contact and spiked to the other fender piles with not less than three boat spikes at each intersection.

The top of the pier protection should be about 4 ft. above high water and the lowest waling piece just at, or just below, low water.

That portion of the fender directly in front of the piers may be bolted to the face of the piers or be carried on piling driven in front of the pier.

Bolting the waling and supporting pieces to the pier saves a few feet on the length of truss required to span a given clear channel, but the pile protection is a more resilient fender and will be safer in collision as it does not transmit its shock to the pier. Whether pile or frame fender is used, the waling pieces and sheer strake should be of the same size as on the wing walls and fastened to their supports in the same sturdy manner.

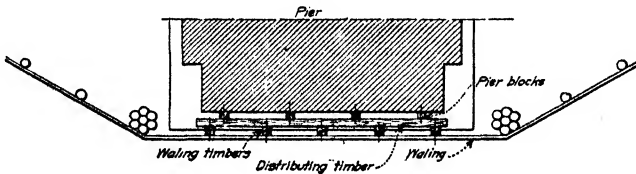

FIG. 65.

With the frame protection, it is best to place those blocks which are in contact with the masonry in such a location that they will transfer their load to a part of the pier least liable to be affected by repeated impacts from heavy boats. The pieces laid across these blocks should support a secondary set of timbers in such a manner that no shock could come into the final blocks except through the bending of the timbers. The sequence of fastening will then be from waling to waling timbers, from waling timbers to distributing timbers and from distributing timbers to the pier blocks, and thence to the pier. This furnishes a resiliency which tends to lessen the shock of impact and thus save the bridge and pier from injury.

In wide channels or in locations where the bulk of the shipping can use the openings under the fixed approach piers, it is sometimes found advisable to leave the fenders out. Their presence does not improve the looks of any structure and in channels subject to great seasonal changes of water level, they may extend far enough out of the water to be quite a detriment to the appearance of an otherwise handsome structure.

In this regard, it should be said that those types of bascules requiring a pier with enclosed walls need a pier protection much more than do the

types which can be supported on simple piers. The unit pier with its comparatively thin walls is much more susceptible to shock and injury than the solid single pier which presents a very much narrower face to the line of navigation. The heavier single pier is, however, much more liable to damage a boat than is the pile or timber protection of the unit pier.

In conclusion, let it be said that when a pier fender is required, nothing but the best is worth while. A fender of light and insufficient construction is a waste of money and affords a false sense of security which may result in an accident that would have been guarded against had there been no fender.

Figure 65 shows the pertinent details of a pier fender used in recent years.

COMPLETE STRUCTURAL DESIGN OF A DOUBLE LEAF SIMPLE TRUNNION DECK BASCULE HIGHWAY BRIDGE

28. Data.

28a. General Description.—The structure considered in this design is substantially the same as illustrated in Fig. 66 and is a double leaf trunnion bascule highway bridge. The particular type chosen for this problem is that designated as "Type 5" in the statement of the Chicago Bascule Bridge Company (see p. 23). Any other of the simple trunnion types would involve a design procedure no different in principle from that hereinafter described.

There will be two concrete piers—one pier on each side of the channel—each pier carrying one leaf and its appurtenant machinery. Each leaf is operated by electric motors geared to pinions which engage racks in the planes of the trusses. There are two motors for each leaf directly connected with each other and to the machinery. When in the lowered position and open for traffic, the two leaves are locked together at the center. When the leaves are in the raised position, the roadway is protected by electrically operated roadway gates. The operation of the center lock is interlocked with the roadway gates and the operation of raising the leaves is interlocked with the operation of the center lock, making it necessary to lower the gates before the center lock can be drawn and then to draw the center lock before the leaf can be raised. There are four houses on the two piers—one on each side of the roadway at each pier. One of these houses contains all the control apparatus of the bridge, one is the operator's quarters and the other two are for storage.

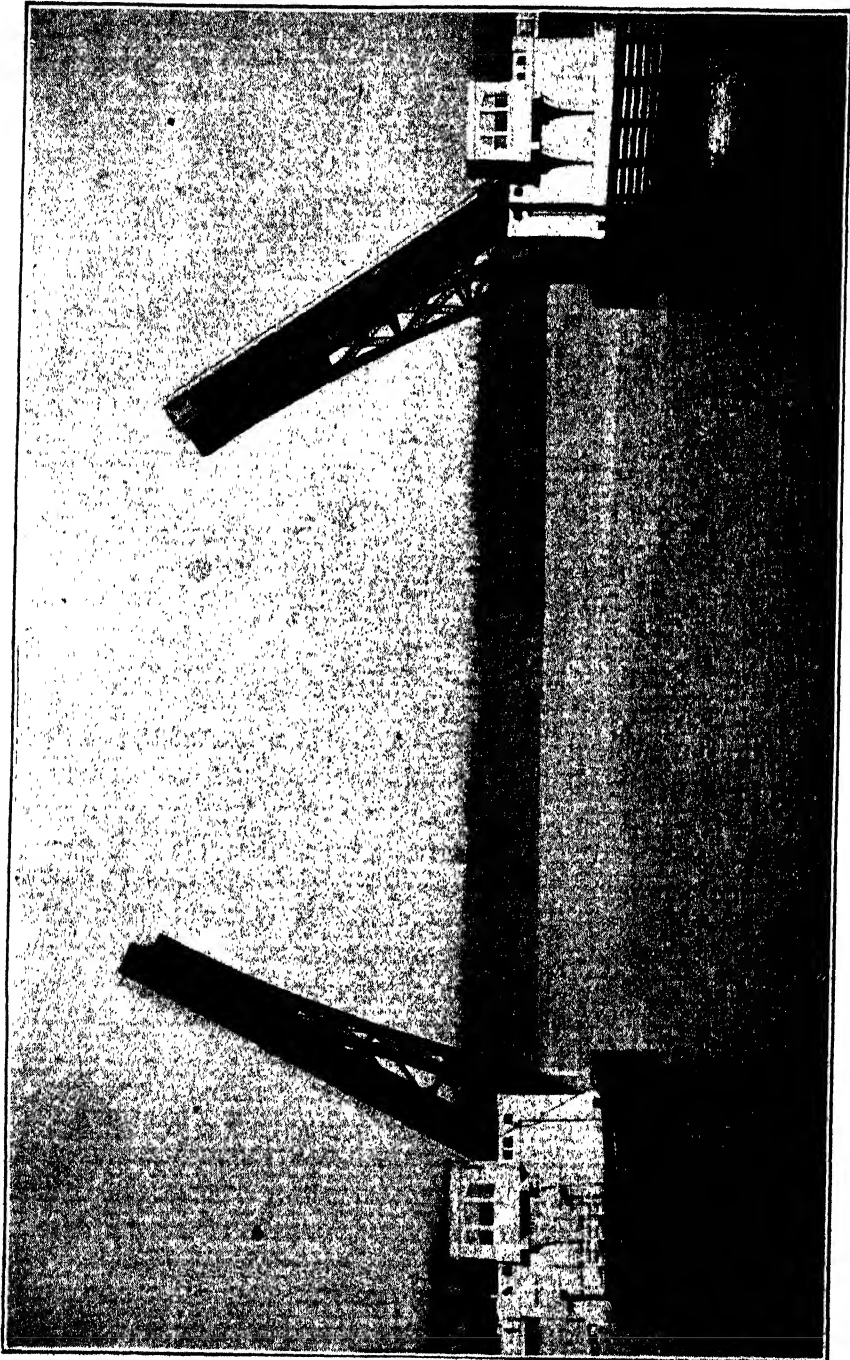

Fig. 66.—Youngs Bay Bridge, Astoria, Oregon.

28b. Governing Dimensions.

Clear channel at water line.....	150 ft. 0 in.
Clear channel at tip of raised leaves.....	120 ft. 0 in.
Elevation of roadway surface.....	+32 ft. 0 in.
Low tide.....	- 3 ft. 0 in.
High tide.....	+10 ft. 7 in.
Probable wave crest.....	+12 ft. 0 in.
Bottom of existing channel.....	-24 ft. 0 in.
Bottom of proposed channel.....	-33 ft. 0 in.
Bottom of piers.....	-38 ft. 0 in.
Clear width of roadway.....	20 ft. 0 in.
Minimum pile spacing.....	2 ft. 6 in.

28c. Loads.—The structure will be designed to carry its own dead load, properly distributed, together with the specified live loads, without exceeding in any part the allowable unit stresses as given later.

Dead Load.—The dead load consists of the estimated weight of the entire structure. Plain timber is assumed to weigh (for design purposes) 4 lb. per b. ft., concrete 150 lb. per cu. ft., and creosoted timber 5 lb. per b. ft.

Live Load.—The live load consists of a uniform load of 80 lb. per sq. ft. and two 15-ton trucks of the following dimensions: Distance between axles 10 ft., wheel gage 6 ft. Two-thirds of the load on the rear wheels. Space occupied by the truck 20 ft. long and 9 ft. wide.

Impact.—The computed live load stresses are increased by the following percentages in order to provide for the dynamic increment of stress due to moving loads:

Floor stringers.....	60 per cent
Intermediate floor beams.....	50 per cent
Stringers and floor beams at break in floor... ..	100 per cent

The maximum live load stresses in the trusses are increased by a percentage obtained by the formula P (percentage) = $\frac{100}{2.6L + 300}$, where L = the loaded length of bridge in feet producing the maximum stress in the member. When the bridge is in motion, or open, the dead load stresses are increased by a flat 20 per cent to provide for vibration effects, etc., etc.

Impact at Anchorage.—The computed uplift stresses in the anchorage at the heel of the anchor arm are not increased in accordance with the

above formula, but receive a 40 per cent increase. The anchorage detail, however, is attached to a mass of masonry weighing not less than twice the amount of the computed uplift.

Wind Load.—When in the closed position, the bridge is designed for a lateral load of 450 lb. per lin. ft. of bridge, of which 150 lb. is considered acting on the upper chord, 150 lb. on the lower chord, and 150 lb. acting in the plane of the roadway surface. These forces are all considered as moving. When in the open position, a wind force of 15 lb. per sq. ft. is considered as acting in any direction. The stresses caused by the above specified lateral forces are not increased for impact by any percentage such as given by the formula above.

For stresses produced by longitudinal or lateral wind forces combined with those from live load, dead load and impact stresses, the allowed unit stresses may be increased 25 per cent over those given in the table of allowed stresses, but the section shall not be less than would be required if the wind forces were neglected and the 25 per cent increase not allowed.

Shear at Center of Bridge.—The amount of shear transferred from one leaf to the other through the center lock is assumed to be the amount given by the following formula:

$$S = \frac{P}{4} \left(\frac{A}{L} \right)^2 \left(3 - \frac{A}{L} \right)$$

where S = shear carried by center lock.

P = any concentrated load.

A = distance of P from $L6$ (horizontal).

L = length of forward arm ($L6$ to $L1$ horizontal).

28d. Permissible Stresses.—The size and make-up of each member shall be proportioned for stresses due to the following loads, and combinations of loads:

(1) Dead load only.

(2) Dead load, live load and impact.

(3) Dead load, live load and impact, together with wind loadings.

For these various load combinations, the permissible unit stresses given in the following table shall not be exceeded:

STRUCTURAL STEEL

Kind of stress	Permissible stress for combined loads, dead, live and impact (lb. per sq. in.)	Permissible stress for dead load only (lb. per sq. in.)
Axial and bending tension on net section of:		
Structural steel.....	16,000	12,000
Upset bars and rods where not annealed.....	12,000	9,000
Axial compression on gross section ¹ (L = unsupported length of member in inches)	16,000-70 $\frac{L}{r}$	12,000-50 $\frac{L}{r}$
Direct compression on:		
Cast-steel bearing and structural steel plates.....	16,000	12,000
Cast-iron blocks.....	14,000	10,000
Bending on:		
Extreme fiber of pins.....	24,000	18,000
Shearing on:		
Rivets and turned bolts in floor connections, shop and field.....	8,000	6,000
Pins and shop rivets, except in floor connections.....	12,000	10,000
Turned bolts and field rivets except in floor connections.....	10,000	8,000
Web of girders, net section.....	12,000	10,000
Web of girders, gross section.....	10,000	8,000
Bearing on:		
Rivets and turned bolts in floor connections, shop and field.....	16,000	12,000
Pins and shop rivets, except in floor connections.....	24,000	20,000
Turned bolts and field rivets, except in floor connections.....	20,000	16,000
Expansion rollers, per lin. in..... (d = diameter of the roller in inches)	500d	450d

¹ $\frac{L}{r}$ shall not exceed 100 for main members nor 120 for subordinate members.

REINFORCED CONCRETE

Reinforced concrete shall be designed for the following permissible unit stresses in pounds per sq. in.:

Kinds of stress	Permissible stress for combined loads, dead, live and impact (lb. per sq. in.)	Permissible stress for dead load only (lb. per sq. in.)
Steel reinforcement in tension.....	16,000	12,000
Steel in compression, 15 times stress in surrounding concrete.....		
Steel in shear.....	12,000	9,000
Concrete in tension.....	0	0
Concrete in compression due to bending.....	650	500
Concrete in bearing.....	400	300
Concrete in shear, beams having no shear reinforcement.....	40	30
Concrete in shear (diagonal tension), beams having shear reinforcement of bent-up bars and stirrups.....	120	90
Bond of concrete and deformed bars.....	100	70

ALLOWABLE STATIC PRESSURE ON MASONRY

Unreinforced mass concrete may be loaded as follows:

1:2½:5 concrete.....	500 lb. per sq. in.
1:2:4 concrete.....	650 lb. per sq. in.

28e. Counterweights.—The counterweights shall be so designed that they will balance the moving part in all positions and so fashioned that they can be easily and properly adjusted for variation in weight by adding or removing definitely located weights. They shall be of concrete construction, built on and around a structural frame thoroughly reinforced and hooped, or else encased in steel boxes.

28f. Anchor Arm Lateral System.—The lateral bracing in the plane of the lower chord will be designed to extend to the trunnions as well as to the anchorage at the heel of the truss and will be proportioned to carry the full load to either point.

28g. Buffer Blocks.—Both the anchor buffer blocks and the blocks for stopping the bridge in the open position are to be made of sound, well-seasoned white oak, entirely free from knots or other imperfections.

Other details of design and fabrication are according to the ordinary rules for such work as found in the various specifications for the design and fabrication of steel bridges.

29. Design of Floor System.—The mathematical work involved in the design of flooring, stringers, and floor beams is exactly similar to that for any fixed highway span, and need not be given in full at this point. Following is a brief synopsis of the floor system design for the problem in hand.

29a. Flooring.—The type of flooring selected will consist of a laminated timber sub-floor supporting a creosoted wood block wearing surface. If a 5-ft. stringer spacing be assumed, a 2- X 6-in. decking will be ample to carry the maximum loading. If an asphaltic wearing surface were to be employed, the 2- X 6-in. decking would prove rather deficient in stiffness and might cause a cracking of the surface. In this case, a deeper deck or a closer stringer spacing would be highly advisable. For this problem, the flooring will be assumed to consist of a 2- X 6-in. laminated deck supporting a 3½-in. creosoted wood block wearing surface, making in all, a thickness (when sized) of 9 in.

29b. Stringers and Floor Beams.—These are designed in the ordinary manner with the following results:

STRINGER MOMENTS	FT.-LB.
D.L.	7,700
L.L.	39,200
Impact.....	23,500
	<hr/>
Total.....	70,400

Section modulus required $(70,400) (12) \div 16,000 = 53.0$. Use five lines of 15-in., 42-lb. I-beams.

INTERMEDIATE FLOOR BEAM MOMENTS	FT.-LB.
D.L.	58,000
L.L.	153,000
Impact (60 per cent).....	92,000
	<hr/>
Total.....	303,000

Section modulus required $(303,000) (12) \div 16,000 = 227$. Use a 26-in., 90-lb. Bethlehem section.

The end floor beams carry practically the same dead and live loadings, but the specifications provide for a 100 per cent increment for impact. The total maximum moment is, therefore, about 360,000 ft.-lb. and the above 26-in., 90-lb. beam must be stiffened by the addition of flange plates top and bottom. Plates, $10 \times \frac{5}{8}$ in., will prove more than ample.

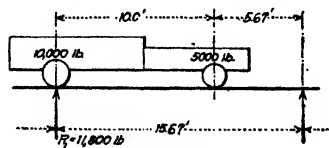

FIG. 67.

Figure 67 indicates the live load floor beam reaction assumed in the foregoing calculations; Figs. 68 and 69, the assumed placement of trucks

for computing the maximum live load moment on floor beams; and Fig. 70 is a sketch of the flange plates adopted for the end floor beam, showing the assumptions made in computing the section modulus of the same.

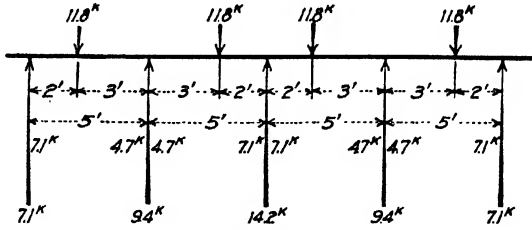

FIG. 68.

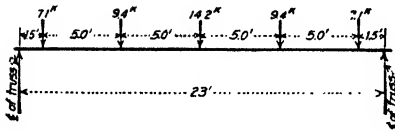

FIG. 69.

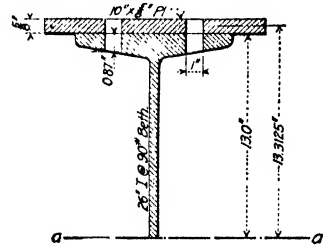

FIG. 70.

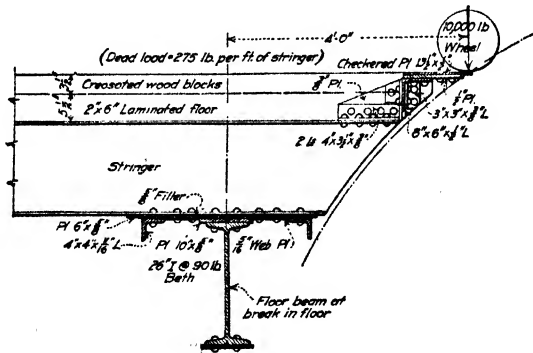

FIG. 71.

The stringer at the break in the floor has a maximum overhang of 4 ft., as indicated in Fig. 71. Assuming a dead load of 275 per lin. ft. of stringer, the moments are as follows:

	FT.-LB.
D.L. moment $(275)(4)(\frac{1}{2})$	= 2,200
L.L. moment $(10,000)(4)$	= 40,000
Impact allowance (100 per cent)	= 40,000
Total design moment	= 82,200

This moment requires a section modulus of 61.1. The 15-in., 42-lb. I-section used for the rest of the stringer system is only slightly under the above requirement and may, therefore, be used for the overhanging portion as well. (The total stress is 16,700 lb., or only 700 lb. above the allowable.)

29c. Horizontal Girder (Fig. 71).—Assume $1\frac{1}{2}$ - \times - $1\frac{1}{2}$ - \times - $\frac{1}{8}$ -in. angles nailed to the sub-floor, at 24-in. centers, transverse with roadway, to support the blocks. The dead weight of the floor which comes on the horizontal girder when the leaf is open is as follows (considering the length of the moving floor as 82.3 ft.):

	Interior stringers	Outside stringers
Blocks (82.3)(5)(3½)(5).....	7,200	3,600
Flooring (82.3)(5)(5½)(4).....	9,060	4,530
Stringers (82.3)(42).....	3,450	3,450
Angles for blocks at 1.25 lb. per ft. (1.25)(5)(42).....	260	130
Floor beams 6 at 90 lb. \times 5 ft. 0 in.....	2,700	2,700
Totals.....	22,670	14,410
or say.....	23 kips and 15 kips	

The moments will be as follows (see Fig. 72):

$$(49.5^k)(11.5) - (15)(10) + (23)(5) = 305 \text{ kip-ft.} = 3,660,000 \text{ in.-lb.}$$

Assume a web plate $32 \times \frac{5}{16}$ in., flange angles $4 \times 4 \times 1\frac{1}{16}$ in., and flange plates $6 \times \frac{5}{8}$ in. (see Fig. 71). Then, for moment, effective $d = 32 - (2)(2.02) = 27.96$ in.

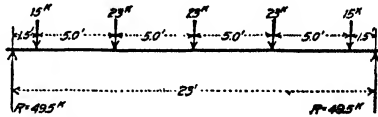

FIG. 72.

$$\begin{aligned} \text{Flange area} &= \frac{1}{8} \text{ web} = 1.25 \\ &1 \text{ angle} = 5.03 \\ &1 \text{ plate} = 3.75 \end{aligned}$$

$$10.03 \text{ sq. in.}$$

Deducting one hole, or 1.62 sq. in., will give a net flange area of 8.41 sq. in.

Maximum fiber stress = $3,660,000 \div (27.96)(8.41) = 15,600$ lb. per sq. in.

$$\text{Area of web} = 10 \text{ sq. in. (gross)}$$

$$\text{Total shear} = 49,500 \text{ lb.}$$

$$\text{Unit shear} = 4,950 \text{ lb. per sq. in., which is satisfactory.}$$

30. Design of Main Truss Members.—Thus far the designing has been of an absolute nature. That is to say, sufficient conditions have

been given to enable a correct design to be made without the necessity of first making an approximate and then a final calculation before the actual dead load was near enough to that assumed to bring the calculated stresses within the limit of error. The figures just given for sizes of flooring, stringers, etc., are to be used in the actual detailing of the structure. In the case of the truss members, however, the procedure is different.

In this case, the weight of the truss is not known with any certainty and there is usually insufficient data on which to base even a fair estimate of the weight per foot of truss.

It is therefore, necessary to make a very rough calculation of the required sections and use the resulting weights at each panel to calculate the dead load stresses for use in designing the final make-up of the truss. If on the completion of this second design, the weights are materially different from those first assumed, it may be necessary to recalculate the dead load stress and alter the sections slightly to conform to the new weights and stresses. This is properly a method of trial and error, but in practice, it is very seldom that a third calculation is ever necessary.

The method of procedure will be to compute the weight of the dead panel load at L_1 (Fig. 73) by assuming a weight for the end panel of the main truss and adding the floor and other loads above determined. Then with this load, the moment will be computed at L_2 due to the dead load of the truss and to the live load that can come on the end panel. This will give a basis on which to calculate the required section at L_2 . From this section, the dead load at L_2 can be corrected and the moments and section at L_3 can be computed. By carrying this process to L_6 , the entire weight of the cantilever arm is computed and with these weights a dead load stress diagram is laid out. This diagram together with those for the live load, wind load and shear lock load give the combinations necessary to design the bridge correctly.

The shape of the truss is governed by the relation of grade to water level, by the clearance desired at the center and by the clear channel desired. In meeting the conditions at this site, the outline shown in Fig. 73 was adopted after various other lengths of counterweight arm, depth of truss, etc., had been tried and eliminated for one reason or another.

Figure 74 shows the general outline of the secondary members and is useful as a guide in identifying the different members which do not appear in an elevation of the truss.

Placing the standard 15-ton trucks with the rear wheels over the end floor beam and loading the rest of the span with uniform live load, gives the maximum stresses in the chords from live load. The panel loads resulting from this placing are as follows (10,000 lb. being one rear wheel load):

$$\begin{aligned}
 U1 &= (10,000)(2) + (2)(5,000)\left(\frac{5.67}{15.67}\right) = 20,000 + 3,600 = 23.6 \text{ kips} \\
 U2 &= 6,400 + (15.67 \div 2)(10)(80) = 6,400 + 6,300 = 12.7 \text{ kips} \\
 U3 &= (15.67)(10)(80) = 12.5 \text{ kips} \\
 U4 &= U5 = 12.5 \text{ kips} \\
 U6 &= (7.83 + 3.5)(10)(80) = 9.0 \text{ kips}
 \end{aligned}$$

Figure 75 shows the placing of the live load for maximum chord stresses and also for maximum web stresses back as far as panel point 4, but not including *LA-U5*.

30a. Preliminary Calculation of Dead Loads.—Dead load at panel point *U1-L1*: The floor system weighs approximately 600 lb. per ft. of truss. The length of truss tributary to panel point 1 is half of the panel 1-2 plus the overhang between panel point 1 and the center of the channel. *U1-U2* is 15 ft. 8 in., half of this is 7 ft. 10 in. The overhang is about 8 in., making 8 ft. 6 in. in all. Total weight of floor is, therefore, (8.5)(600) = 5,100 lb. Handrail will be assumed at 150 lb. per ft., or (8.5)(150) = 1,275 lb. For the lower lateral system assume 1,500 lb. at panel point *L1*, which figure is large enough to include the miscellaneous details at this point. Assume the truss or girder to weigh about 350 lb. per lin. ft. with stiffeners and rivets, or (8.5)(350) = 3,000 lb. The total at *U1* will then be

Floor.....	5,100
Handrail.....	1,275
Truss.....	1,700 (portion tributary to <i>U1</i>)
Total D.L.....	8,075—say 8,000 lb.

The load at *L1* will be the weight of the lateral system at that point and the balance of the truss. These two items are 1,500 and 1,300 lb. respectively, and give a dead panel load at *L1* of 2,800 lb.

For purposes of this computation, it will be close enough to take the entire panel load at any point and assume one-fourth on the bottom or unloaded chord and three-fourths on the top or loaded chord.

The total dead weight at panel point 1 is 10,800 lb. This gives a dead load moment at panel point 2 of (10,800)(15.67), or 169,500 ft.-lb. The live load moment at panel point 2 is due to the standard 15-ton truck with the rear wheels over the floor beam at *U1* and the front wheels toward panel point 2. The center of gravity of the standard truck is 3.33 ft. ahead of the rear wheels. The total weight is 15 tons. As there can be two of them, side by side, each truss carries one full truck load.

The front end of the truck is almost at floor beam 2, so no account need be taken of any uniform live load in the end panel.

The distance from panel point 2 to the center of gravity of the truck is $15.67 - 3.33 = 12.34$ ft. and the live load moment is $(12.34)(30,000) = 370,000$ ft.-lb. Impact will average about 30 per cent. This gives an impact allowance of 111,000 ft.-lb. The approximate total moment at panel-point 2 is then $169,500 + 370,000 + 111,000$, or 650,500 ft.-lb.

The distance out to out of flanges at panel point 2 has been selected as 4 ft. $4\frac{3}{4}$ in. Allowing 7.5 in. on each flange for distance to center of gravity of flange area gives an effective depth of 38 in. (approximately) and a stress in the flange of $650,500 \text{ ft.-lb.} \div 3.17 = 205,000$ lb., requiring a net area of 12.9 sq. in. The flanges may, therefore, be composed of four $6 \times 4 \times \frac{3}{8}$ -in. angles with one hole out. The net area is 3.28 sq. in. each, or a combined net area for the four of 13.12 sq. in.

The shear at panel point 2 is all of the dead load at panel point 1, plus the live load at point 1, plus the dead and live load tributary to point 2. This is 10,800 lb. + 30,000 lb. + (say) 20,000 lb. dead load at 2, plus one-half a panel of live load, or $(10)(80)(15.67) \div 2 = 6,300$ lb., making a total maximum shear of approximately 67,100 lb. The required area for the web of the girder will then be $67,100 \div 10,000$, or 6.71 sq. in. With a depth of 4 ft. 6 in., the required thickness would be $6.71 \div 54.0$, or 0.24 in. This being too thin to consider, the web will be made $\frac{5}{16}$ in. thick unless the shear at panel point 3 requires it to be thicker.

The weights at panel point 2 are then as follows:

Floor system.....	(15.67) (600)	= 9,420
Handrail.....	(15.67) (150)	= 2,400
Web plate.....	(15.67) (54)	= 850
Flanges.....	(8) (15.67) (12.3)	= 1,540
Stiffeners, say.....		= 250
Laterals, say.....		= 1,500
Rivets and miscellaneous.....		= 400
		<hr/>
Total dead panel load of.....		16,360
		say 16,400 lb.

Dividing this as mentioned above into one-fourth at L2 and three-fourths at U2 gives L2, 4.1 kips, and U2, 12.3 kips.

Proceeding to panel point 3, the moments will be as follows:

Dead load		
(10,800) (31.33)		= 339,000
(16,400) (15.67)		= 257,000
<hr/>		<hr/>
27,200		596,000 ft.-lb.

Live load (truck at 15 tons and uniform live load at 80 lb. per sq. ft. on 15.67 × 10 ft.).

$(30,000) (28.0)$	= 840,000
$(12,500) \left(\frac{15.67}{2}\right)$	= 98,000
42,500	938,000
Impact 30 per cent	282,000
	1,220,000 ft.-lb.

Making a total moment at point 3 of 1,816,000 ft.-lb.

The distance between chords at this point is 5 ft. 7¼ in. This gives a stress of 1,816,000 ÷ 5.6, or 325,000 lb. in the flanges of the girder and in the top chord member U3-U4. This will require an area of steel in the flanges of the girder of 325 ÷ 16, or 20.2 sq. in., and the same in member U3-U4.

At 3.41 lb. per ft. per sq. in., the weight per foot of flanges would be (20.2) (3.41) = 69.5 lb. Allowing 50 per cent for details and gusset plates, would give roughly 110 lb. per ft. as the weight of U3-U4.

The shear at point 3 would be 27,200 D.L. plus 42,500 L.L. plus (42,500) (0.3) impact, or a total of 82,450 lb., requiring 8.2 sq. in. net of web plate at point 3. The 5/16-in. plate in the web has an area of (67)(5) ÷ 16 = 20.9 sq. in. and so is amply strong.

The shear in panel 3-4 would be from 15 kips to 20 kips more than in panel 2-3 from D.L.; 12.5 kips more from L.L. and four kips more from impact, making the total increase, say 35 kips over panel 2-3. The shear in panel 2-3 was 82,450 lb. Then the approximate shear in panel 3-4 would be about 118,000 lb. requiring a steel area for L3-U4 of 118,000 ÷ 16,000, or 7.4 sq. in. Allowing for slope and details will bring the weight of this to about double, or say (2) (7.4) (3.41) = 50 lb. per ft. of truss.

The weight of L3-L4 will be assumed as 160 lb. per ft. by comparison with U3-U4 and estimating the increase due to larger moment.

The loads at point 3 are as follows:

Floor system.....	(15.67)(600)	= 9,420
Handrail.....	(15.67)(150)	= 2,400
Web plate.....	(7.83)(57)	= 450
Girder flanges.....	(7.83)(110)	= 860
Girder stiffeners.....	(6)(5)(7.2)	= 220
U3-U4.....	(7.83)(110)	= 860
U4-L3.....	(7.83)(50)	= 390
L3-L4.....	(7.83)(160)	= 1,250
Laterals, say.....		= 1,600
Details, etc.....		= 1,407

Total = 18,857 say 18,900 lb.

which gives 14.2 kips at *U3* and 4.7 kips at *L3*.

Proceeding in this manner the approximate dead load concentrations for the various panel points are readily calculated. The results are as follows:

PANEL POINT	DEAD LOAD CONCENTRATION
1	10,800
2	16,400
3	18,900
4	22,700
5	23,700

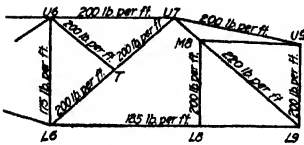

FIG. 76.

For the members of the counterweight arm, the preliminary weight assumptions shown in Fig. 76 may be made without material error. Based upon these assumed values, the following dead load concentrations may be calculated.

PANEL POINT	DEAD LOAD CONCENTRATION
6	23,200
<i>U7</i>	6,200

30b. Determination of Dead Load Stresses in Counterweight Arm.—With the above dead loads at hand, the next step in the analysis is the determination of the size and volume of the counterweight and the calculation of dead load stresses in the rear or counterweight arm of the truss.

Taking the D.L. moments about the trunnion, will give the amount of concrete necessary to balance the structure. With this weight determined, the stresses in the anchor arm are readily calculated.

MOMENTS AHEAD OF TRUNNION	
(10,800)(86.33) =	940,000
(16,400)(71.16) =	1,166,000
(18,900)(55.50) =	1,048,000
(22,700)(39.83) =	905,000
(23,700)(24.16) =	574,000
(23,200)(8.50) =	197,000

115,700 4,830,000 ft.-lb.

MOMENTS BACK OF TRUNNION	
<i>U6-U7</i>(1,800)(3.7) =	6,670
<i>U6-T</i>(2,280)(3.7) =	8,450
<i>L6-L9</i>(4,500)(12.0) =	54,000
<i>U7-L9</i>(4,800)(15.9) =	76,200
<i>U7-U9</i>(3,400)(15.9) =	54,100
<i>U9-U9</i>(2,600)(24.0) =	62,500
Girder <i>A</i>(5,500)(11.0) =	60,500
Girder <i>B</i>(5,500)(24.0) =	132,000

Side and bottom plates

and sways. $\frac{(8,500)(17.5)}{38,880 \text{ lb.}} = 148,500 \text{ ft.-lb.}$
 602,920

The moment 4,830,000 - 602,920 or 4,227,080 must be balanced by a mass of concrete at a distance of 17.5 ft. from the center of rotation (see Fig. 73). The amount of concrete needed is, therefore, 4,227,080 ÷ 17.5 = 242,000 lb.

Considering concrete to weigh 150 lb. per cu. ft., the total quantity required per truss is $242,000 \div 150$, or 1620 cu. ft. Half the distance between trusses is 11.5 ft. which leaves 140 sq. ft. as the required end area, or on a height of 11 ft., the required width will be 13 ft.

The foregoing paragraph has considered the limiting outline of the counterweight as the center lines of the bounding members. Allowance for the pockets in the counterweight to provide space for balance blocks can be obtained by extending the concrete out and around the supporting members if necessary in the final design.

Distributing this counterweight load equally among the four panel points at its corners gives 60.5 kips to the panel point. Then with 6.2 kips as the weight of metal at *U7*, there is 32.6 kips of the metal in the counterweight arm left to be distributed between the four panel points about the counterweight. Dividing this as before, that is, three-fourths to the lower end and one-fourth to the upper end (the bottom chord of the counterweight end being considered the loaded chord) gives 4.0 kips to each of the upper points and 12.3 kips to each of the lower points, which added to the 60.5 kips of concrete gives a loading of 64.5 kips at *M8* and *U9*, and 72.8 kips at *L8* and *L9*. For purposes of obtaining the reaction on the trunnion, 3.8 kips of trunnion plates are assumed in addition to the weights of the truss members which frame into that point. This gives (approximately) seven kips as the load at *T*, and the dead load stress diagram is then drawn as in Fig. 75.

This diagram is in two parts because it is impossible to begin at the outer end and continue clear through to the rear end on account of the presence of three unknown stresses at *U6* and *L6*. Consequently, it is customary to begin at *U1* and run the diagram back to *L6* and then begin at *L9* and run ahead to *L6*, thus completing the stress analysis for dead load closed, but with the diagram in two parts. (It is possible to compute the stress in *L6-L9* algebraically and add this value into the stress diagram when *L6* is reached, but the usual method is to rely on the graphic solution and use the algebraic as a check.)

Having the dead load stresses in the closed position, it is necessary to run another set of diagrams for stress at 90 deg. open (see Fig. 75) in order to see which members have a larger stress when partly open than when either fully open or closed. From this it is seen that *U6-L6*, *U6-T* and *L6-T*, have their greatest stress when partly open. The amount of this stress is shown under the heading "maximum stresses" in Fig. 75. The four diagrams entitled—(1) "Dead Load River Arm (Bridge Closed)," (2) "Dead Load River Arm (Bridge Open 90 deg.)," (3) "Dead Load Counterweight Arm (Bridge Closed)," and (4) "Dead Load Counterweight Arm (Bridge Open 90 deg.)"—will give all the necessary dead load stresses required for the design of the structure. These diagrams are also used to determine what angle of opening is

critical for each member having its largest stress when partly open. It is observed that the leaf, although composed of a plate girder section for the outer two panels; has been considered as a frame throughout its entire length. This is done in order to facilitate the graphic analysis. The design of the plate girder sections may be readily worked out later.

30c. Live Load Stress Diagrams.—Before beginning the live load stress diagrams, it is necessary to compute the live load reactions at the anchorage and at *L6*. The only loading which need be computed for stress in the anchor arm is the full live load condition of Fig. 75.

Taking moments about *L6* gives the following:

$$\begin{array}{r}
 (23.6)(78.33) = 1,850 \\
 (12.7)(62.67) = 795 \\
 (12.5)(47.00) = 587 \\
 (12.5)(31.33) = 392 \\
 (12.5)(15.67) = 196 \\
 (9.0)(0) = 0 \\
 \hline
 82.8 \qquad \qquad 3,820 \text{ kip.-ft.}
 \end{array}$$

This must be resisted by a downward reaction at the anchor column. The stress in the anchor column which is 34.2 ft. from the center line of *U6-L6* will be $3,820 \div 34.2$, or 112 kips. The stress in *U9-L9*, however, will be greater as it is only 32.5 ft. away from the center line of *U6-L6*.

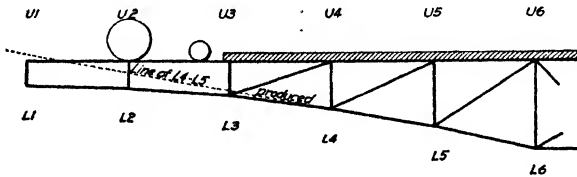

FIG. 77.

As this is the stress upon which the stress diagram depends, it is taken instead of the anchor column reaction when solving for the stresses in the counterweight arm. It is $3,820 \div 32.5$, or 118.0 kips.

The live load reaction at *L6* is the sum of all the live loads on the river arm plus the stress in *U9-L9*, or 200.8 kips.

In drawing the live load stress diagrams, members *U7-U9*, *U9-M8* and *M8-L8* are not considered, as they have no live load stress. Member *U9-L9* is merely a post loaded at the anchor bracket with the 118.0 kips of live load reaction.

Full load, as in Fig. 75 will give maximum conditions for the chords and for all web members back to *U4-L4*. As the line of action of *L4-L5*

intersects the line of the top chord just forward of U_2 , it is necessary to place the large truck wheel at U_2 (with no load on panel 1) to obtain a maximum stress in L_4-U_5 and U_5-L_5 (see Fig. 77).

The line of L_5-L_6 intersects the top chord at a point just back of U_2 . For maximum stress in L_5-U_6 , the large truck wheel should again be moved, this time to U_3 , and no load at U_1 or U_2 (see Fig. 78).

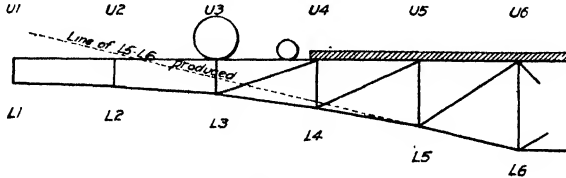

FIG. 78.

For minimum load at L_4-U_5 and U_5-L_5 , the truck should be placed as in Fig. 79, but with no uniform load on the span. For minimum load on L_5-U_6 , the uniform live load should be added up to the center of panel 2-3 (see Fig. 80), or in other words, the live panel load given at U_1

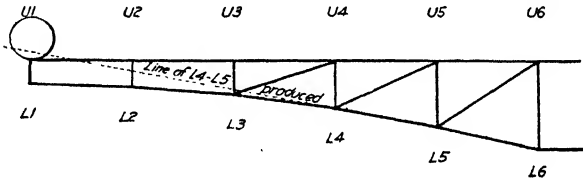

FIG. 79.

should be used alone to obtain minimum stresses in L_4-U_5 and U_5-L_5 and panel loads at U_1 and U_2 should be used to obtain minimum stress in L_5-U_6 .

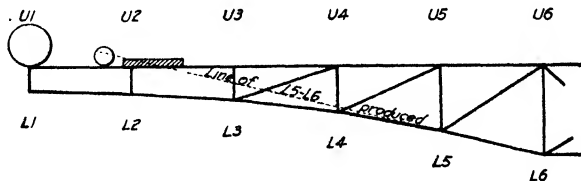

FIG. 80.

30d. Shear Lock Stresses.—The value of the stress transferred from one leaf to the other by virtue of the shear lock at the center of the span may be determined very closely by means of the following empirical formula:

$$S = \frac{P}{4} \left(\frac{A}{L} \right)^2 \left(3 - \frac{A}{L} \right)$$

Where

- S = value of the shear at the center lock for a given load P on the span.
- A = distance from the support to the given load P .
- L = distance from the support to the center lock.

For a full panel load at the various panel points, the value of S as computed by the above formula is as follows:

PANEL POINT LOADED	VALUE OF P	VALUE OF $\frac{A}{L}$	VALUE OF S , POUNDS
U5	12,500	$\frac{1}{5}$	350
U4	12,500	$\frac{2}{5}$	1,300
U3	12,500	$\frac{3}{5}$	2,700
U2	12,500	$\frac{4}{5}$	4,410
U1	6,250	$\frac{5}{5}$	3,125

By means of an ordinary Maxwell diagram, the stress in each member of the truss due to a unit load at the shear lock is now determined (see Fig. 83).

Taking the values from the above unit shear lock stress diagram and

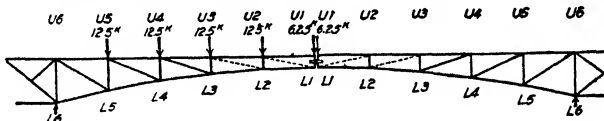

FIG. 81.

multiplying them by the greatest possible shear lock stress which can occur when the member is under maximum (or minimum) stress from loads on its own leaf, the amounts to add to the design stress to take care of shear lock stresses may be determined.

Consider member L1-L2 on the right-hand leaf (see Fig. 81). Its

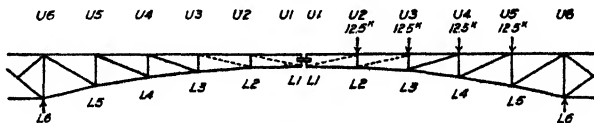
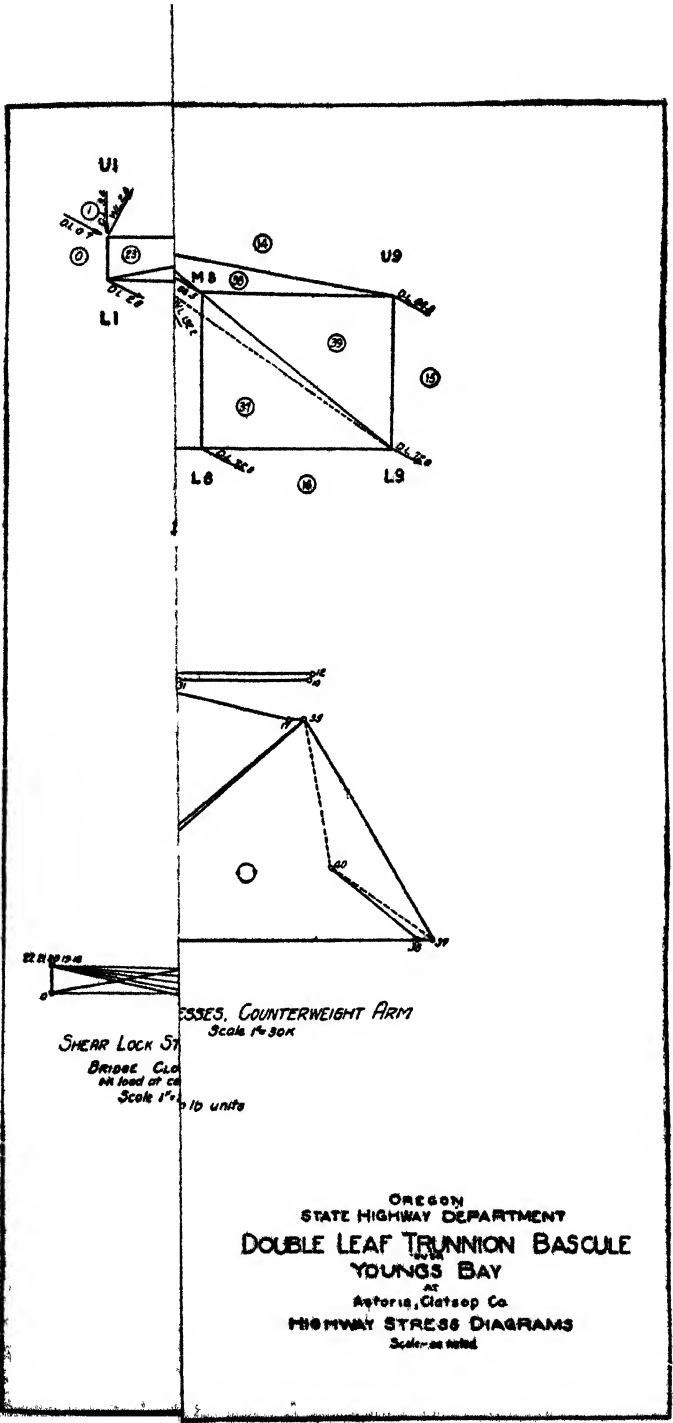

FIG. 82.

maximum stress occurs when its panel point 1 is fully loaded. Place full load on panel point 1 of the opposite leaf to offset this load and then load fully all panels of the left-hand leaf. The shear lock stress transferred will then be the sum of the shear lock loads for panels 5, 4, 3 and 2, or $0.35 + 1.30 + 2.70 + 4.41 = 8.76$ kips, and the shear lock stress in L1-L2 will be 8.76 times the stress in L1-L2 under one kip load at the shear



STRESSES, COUNTERWEIGHT ARM
Scale 1"=30k

SHEAR LOCK STRESS
Drippe. Clo.
At load of ca.
Scale 1"=10 units

OREGON
STATE HIGHWAY DEPARTMENT
DOUBLE LEAF TRUNNION BASCULE
YOUNGS BAY
AT
Astoria, Clatsop Co.
HIGHWAY STRESS DIAGRAMS
Scale-as noted

lock. This is 4.6 kips. The shear lock stress in $L1-L2$ is then $(8.76)(4.6)$, or 40.3 kips. If all panels of the right-hand leaf were loaded except panel 1, and no load were placed on the left hand leaf (see Fig. 82), there would be an uplift at the shear lock on the right-hand truss which would cause the shear lock stress to have opposite sign. Shear lock stresses are thus seen to have two values opposite in sign. Care must, therefore, be taken to see that the correct sign is used when combining for maximum or minimum stress because it may not be possible to obtain maximum shear lock stress at the same time that maximum live load is obtained, in which case, the shear lock stress may have no effect on the design stress.

The principal shear lock stresses are as follows:

$U3-U4$	Stress for 1 kip load at center = 6.50
	Shear lock stress = $(4.35)(6.5) = 28.20$
$L3-U4$	Stress for 1 kip load at center = 2.00
	Shear lock stress = $(1.65)(2.0) = 3.30$
$L3-L4$	Stress for 1 kip load at center = 6.70
	Shear lock stress = $(1.65)(6.7) = 11.10$
$U4-L4$	Stress for 1 kip load at center = 0.00
	Shear lock stress = 0.0
$U4-U5$	Stress for 1 kip load at center = 6.70
	Shear lock stress = $(1.65)(6.7) = 11.10$
$L4-L5$	Stress for 1 kip load at center = 6.40
	Shear lock stress = $(0.35)(6.4) = 2.24$
$U5-U6$	Stress for 1 kip load at center = 6.30
	Shear lock stress = $(0.35)(6.3) = 2.20$

The shear lock stress in $L5-L6$ can be neglected because maximum stress occurs with the leaf fully loaded and at that time there can be no downward reaction on this leaf from the opposite leaf.

30e. Dead Load Stresses. Leaf Open.—Thus far all stress diagrams (with the exception of one purely theoretical one for the leaf open 90 deg.) have been drawn for the leaf down. The angle of opening required to give 100-ft. clear span at the tips of the leaves is 62 deg. It is necessary, therefore, to draw stress diagrams for the leaf in this, the fully open, position and determine the dead load and wind load stresses in all the members with the bridge thus raised. These are shown on Fig. 83.

There is one point in connection with the dead load distribution that needs treatment out of the ordinary. This is the distribution of the floor load to the truss. As a horizontal girder was placed under the stringers, between the $L6-U6$ posts, this girder must be considered as carrying the full vertical reaction of the floor system. As the floor is inclined at an angle of 62 deg. with the horizontal or 28 deg. with the

vertical, there will be two components to the floor load at each panel point. One of these will be normal to the floor, the other will be parallel to the floor. All those parallel to the floor will be summed up into one load at the horizontal girder and then divided into two components, one normal to the floor and one vertical. The condition thus represented will be a floor supported at U6 by a vertical reaction and a thrust normal to the floor to offset the sum of the thrusts which are necessary at each panel point to maintain the floor in its inclined position (see Fig. 84).

30f. Wind Load Stresses.—There is a point in connection with the solution of the wind load stresses that needs explanation.

Unlike the dead loads, the wind load must be resisted (to prevent rotation) by some force other than the counterweight. The only point at which this can be accomplished is at the main pinion. This is not on any member. Therefore, it is necessary, for purposes of constructing the stress diagram, to consider two theoretical members, one from the main pinion to U7 and one to L9. This will give very closely the stress in U7-L9 due to wind load, but the actual stress is indeterminate on account of the large rack plate which rivets to T-U7, M8-L9, M8-L8 and L6-L8-L9 and, therefore, distributes part of the wind load to all these members.

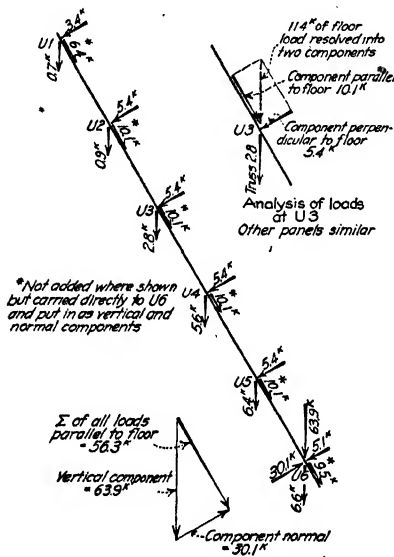

FIG. 84.

The reaction at the main pinion to counteract the wind load is necessarily tangent to the rack circle at the fully open position of the pinion. As the main trunnion is the only other point of contact with the pier when the leaf is in the open position, the main trunnion bearing furnishes the other reaction against wind load and must be so fastened to the pier and main girder as to prevent its being overturned in case of a high wind.

As previously explained, the wind loads are plus or minus, consequently only one direction of wind need be assumed and stresses solved. Reversing the direction of the wind merely reverses the stresses.

This completes the stress analysis work and when the impact values are determined, the stress table can be laid out and the sections of the members designed.

30g. Impact Stresses.—The impact formula specified in this case was $P = \frac{100}{2.6L + 300}$, where P = the percentage to add for

impact and L = the loaded length of truss required to produce the stress to which it is desired to add the impact allowance.

Each member will, therefore, have a certain definite L for its maximum stress and the impact allowance for the different members is as follows:

MEMBER	LOADED LENGTH (FEET)	IMPACT ALLOWANCE
<i>U2-U3, L1-L2</i>		
<i>U1-U2, L1-U2</i>	8	0.31
<i>U3-U4, L2-L3</i>		
<i>U2-L2, L2-U3</i>	24	0.28
<i>U4-U5, L3-L4</i>		
<i>U3-L3, L3-U4</i>	39	0.25
<i>U5-U6, L4-L5</i>		
<i>U4-L4, L4-U5</i>	55	0.23
<i>L5-L6, U5-L5</i>		
<i>L5-U6,</i>	70	0.21
<i>U6-L6, U6-U7</i>		
<i>U7-U9, L6-L8</i>		
<i>L8-L9, L6-T</i>		
<i>U6-T, U7-T</i>	82	0.20
<i>M8-L8, U7-M8</i>		
<i>M8-L9, M8-U9</i>		
<i>U9-L9</i>		

To the dead load stresses in the open, or ready to open position, a flat 20 per cent is added for vibration impact. This is none too much in view of the possibility of rather violent closing due to careless operation.

The next step after having made the stress diagrams is to lay out a table of stresses, as shown in Fig. 73. For convenience, the different portions of the truss are shown at the left margin of the table and double vertical lines separate the stresses for different positions or conditions of the leaves.

As the two panels next to the center line of the channel are to consist of a plate girder section, their design stresses are not listed here but only the final sections shown on this sheet.

In making up the column of area required, it is always advisable to note that the section required for tension members is net, N , and that for compression members is gross, G , as it will save considerable searching when laying out the sections of the members.

The completion of the table of stresses and sections (Fig. 73) completes the design of the main members.

31. Design of Lateral System.—As stated in Art. 28c, the assumed wind load will be 450 lb. per lin. ft. of bridge. The panel length is 15 ft. 8 in. and the distance between chords is 23 ft. Maximum stresses are

caused by full load over the entire leaf and a layout as in Fig. 85 represents the truss system which is to be designed. In this system, the struts take compression and the diagonals are considered to take only tension. At $L1-L1$ and $L2-L2$, no strut will be provided as the floor beam extends down to the top of the chord and a simple bracket will transfer the stress from the diagonals to the floor-beam. All the struts will be assumed as composed of four angles, $4 \times 3 \times \frac{5}{16}$ in., set the same distance back to back as the out to out dimension of the chords, and single laced with $2\frac{1}{4} \times \frac{3}{8}$ -in. lacing bars. The diagonals will be assumed as made of the minimum section, namely, four $3 \times 2\frac{1}{2} \times \frac{5}{16}$ -in. angles, single laced with $2\frac{1}{4} \times \frac{3}{8}$ -in. lacing bars.

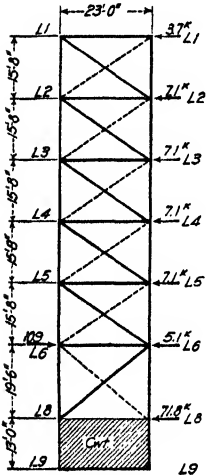

FIG. 85.

The maximum compression in any strut occurs in $L5-L5$ and amounts to 32.1 kips. Dividing this stress by the gross section of the strut, gives a unit stress of about 3.3 kips which is much lower than the allowed unit stress as given by the formula

$$16,000 - 70 \frac{L}{r}$$

The maximum diagonal stress amounts to 39 kips for diagonal $L5-L6$ which has a net area of 5.40 sq. in. The resulting maximum tension is, therefore, only about 7.3 kips. The diagonal system is, therefore, seen to be heavier than needed for actual strength, but will be adopted for the sake of rigidity.

Referring again to the diagram of Fig. 85, the reaction at $L6$ is the force necessary to hold the truss in position against the wind load when the anchor arm is held at the forward end of the counterweight. Taking moments about $L8-L8$ of all the loads on the channel arm and dividing by the distance $L6-L8$ or 19.5 ft. gives the following:

$$(3.7)(97.83) = 362$$

$$(7.1)(82.17) = 583$$

$$(7.1)(66.50) = 473$$

$$(7.1)(50.83) = 360$$

$$(7.1)(35.17) = 248$$

$$(5.1)(19.50) = 99$$

$$(R)(19.50) = 2,125 \text{ kip-ft.}$$

whence, $R = 2,125$ divided by 19.50 or 109 kips.

In like manner taking moments about $L6$, the reaction at $L8$ is found to be 71.8 kips and the sum of the wind loads and the counterweight reaction equals the 109-kip reaction at $L6$.

The stress in L6-L6 strut will be 109 kips and the stress in the diagonal L6-L8 will be 71.8 multiplied by the secant of the angle between the diagonal and the L6-L6 strut, or $(71.8)(1.31) = 94.5$ kips, which will require 5.9 sq. in. of metal in the net section. This is furnished in four angles, $3\frac{1}{2} \times 3\frac{1}{2} \times \frac{5}{16}$ in., which have a combined net section of 6.2 sq. in.

For the L6-L6 strut, four angles are placed with their sides forming a square and the sway frame L6-T fastened to the corner toward the trunnion (see sketch in upper right-hand corner of Fig. 74).

The radius of gyration of four angles, $6 \times 6 \times \frac{3}{8}$ in., with the backs 18 in. apart, is 7.62 (see Fig. 86). The allowable compression is $16,000 - 70\frac{L}{r}$, or $16,000 - 70\left(\frac{(23)(12)}{7.62}\right) = 13,500$ lb. per sq. in. The required area is, then, $109 \div 13.5 = 8.1$ sq. in. Since 17.44 has been furnished, the member is sufficient.

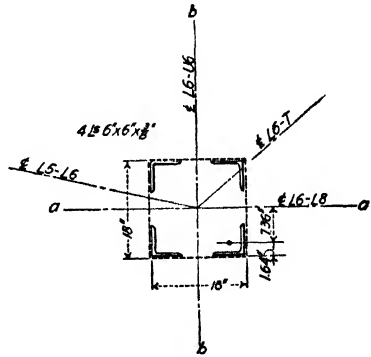

FIG. 86.

The specifications say that the wind load shall be carried to the trunnions and to the counterweight by lateral systems, each of which is capable of carrying the whole stress. The lower laterals carrying the wind load to the counterweight have just been designed.

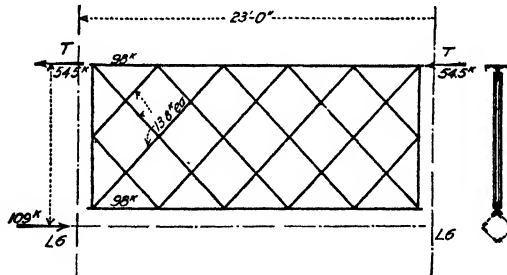

FIG. 87.

For the system to carry the stress to the trunnions, it is necessary to adopt some shape that will provide the necessary strength and yet not require an elaborate fastening at the trunnion. Also there must be some member between the two trusses near the trunnions to take the upper end of the sway frame. From L6 to T is 11 ft. 2 in. If 8 in. is assumed as clearance for the trunnions, there remains 10 ft. 6 in. as the distance between top and bottom chords of the sway frame L6-T. The layout adopted is shown in Fig. 87. This makes the problem the solution of a

lattice portal of 10.5 ft. depth.¹ The stress in the chords is 98 kips and in the web there is 13.8 kips per angle. Assume the web angles the minimum, or $3 \times 2\frac{1}{2} \times \frac{5}{16}$ in.

The total unsupported length of any web member is about 55 in. The radius of gyration of one $3 \times 2\frac{1}{2} \times \frac{5}{16}$ -in. angle is 0.93. The allowable stress is $16,000 - \frac{(70)(55)}{0.93} = 16,000 - 4,150 = 11,850$ lb.

per sq. in. The area of the angle is 1.62 sq. in. and the total stress 13,800 lb. The actual unit stress is, therefore, $13,800 \div 1.62 = 8,600$ lb. per sq. in. which is well within the allowable.

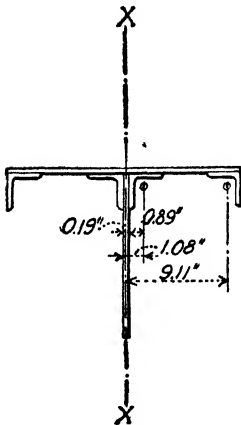

Fig. 88.

The bottom chord of the strut is the member shown in cross-section in Fig. 86. As it has a capacity of $(17.44)(13,500) = 235,000$ lb. to resist the 98-kip reaction, it is ample. For the top chord, a "T" section will be assumed, composed of a stem $14 \times \frac{3}{8}$ in. with two angles $3 \times 3 \times \frac{3}{8}$ in. to connect it to the top plate, which will be a $20 \times \frac{3}{8}$ -in. plate with two angles $3 \times 3 \times \frac{3}{8}$ in. turned down at its outside edges. The $14 \times \frac{3}{8}$ -in. plate will be used as a connection for the lattice angles and will serve as a long gusset plate. The unsupported length of the member will be the distance between connections of lattice angles in the vertical direction and the whole 23 ft. in the horizontal direction. The radius of gyration is as follows (see Fig. 88):

vertical direction and the whole 23 ft. in the horizontal direction. The radius of gyration is as follows (see Fig. 88):

Member	Area	<i>d</i>	<i>d</i> ²	<i>Ad</i> ²	<i>I</i>	<i>I</i> + <i>Ad</i> ²
$14 \times \frac{3}{8}$	5.25	0	0	0	0.1	0
$20 \times \frac{3}{8}$	7.50	0	0	0	250	250
$2 \angle 3 \times 3 \times \frac{3}{8}$	4.22	1.08	1.17	4.9	3	8
$2 \angle 3 \times 3 \times \frac{3}{8}$	4.22	9.11	83	350	3	353

Total moment of inertia about X - X = 611 in.⁴ and the total area is 21.19. The radius of gyration is $\sqrt{\frac{611}{21.19}} = 5.4$.

The allowable compression is $16,000 - (70)(23) \left(\frac{12}{5.4}\right) = 16,000 - 3,600$, or 12,400 lb. per sq. in. The capacity is $(12,400)(21.19) = 261,000$ lb. as against the 98-kip stress from the wind.

The sway frames between the floor beams and the lower lateral struts are for the purpose of maintaining the trusses in a vertical plane under the

¹ JOHNSON, BRYAN and TURNAURE, "Modern Framed Structures," part I, p. 269.

wind load on the top chord. This load is about five kips per panel. Considering the frame at *U5*, the distance between chords is 10 ft. $4\frac{3}{4}$ in. and between trusses 23 ft. The layout of the sway frame is shown in Fig. 74. Taking moments about one lower chord panel point gives for the vertical reaction at the lower chord point $(5.0)(10.4) \div 23 = 2.2$ kips.

The stress in the web diagonals is equal to the above shear multiplied by the secant of the angle of inclination with the vertical and amounts to about 3,000 lb. for which the $3- \times 3- \times \frac{5}{16}$ -in. angles are readily seen to be ample.

The sway frame at *L6* is designed in the same manner, but using a lattice section of minimum angles. The other sway frames *L3* and *L4*, are the same general type as *L5* and need no explanation.

The counterweight is to be hung on and around a structural frame. The worst condition to assume is that the frames mentioned carry the whole load. These frames are called "counterweight truss A," "counterweight truss B," "counterweight laterals" and "counterweight cross frame."

The counterweight truss *A* is located between the *L8-M8* panels of the trusses and the counterweight truss *B* between the *L9-U9* panels. The cross frame is on the center line of the bridge and extends from counterweight truss *A* to counterweight truss *B*. Its top and bottom members being the center struts for the upper and lower lateral systems in the counterweight and its vertical members being the center struts of counterweight trusses *A* and *B*.

Referring now to Fig. 74 and to the dead loads given at the counterweight panel points of the truss outline in Fig. 75. The layout of Fig. 89 can be drawn with one-half the total counterweight load or one truss load at the center and one-half a truss load at each side for the counterweight trusses *A* and *B* when the bridge is in the closed position.

Adding the 20 per cent impact allowance to these members gives the tension diagonals a design stress of 64 kips and the compression diagonals a stress of 57 kips.

Try $6- \times 3\frac{1}{2}- \times \frac{1}{2}$ -in. angles with the 6-in. legs $\frac{3}{8}$ in. apart and the $3\frac{1}{2}$ -in. legs turned to the outside of the counterweight. The radius of gyration is 1.41. The allowable compression on a length of 15 ft. 9 in. is $16,000 - 70(15.75) \left(\frac{12}{1.41} \right) = 6,600$ lb. per sq. in. The required area for 57 kip stress is 8.6 sq. in. The section furnished having 9 sq. in. is satisfactory.

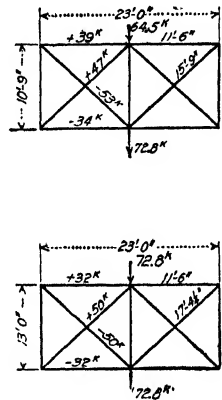

FIG. 89.

For the tension diagonals, the stress of 64 kips requires a net area of 4 sq. in. and the same section will be used for this as for the compression diagonals. The top and bottom and center vertical members will be made of the same section for the sake of uniformity.

When in the fully open position, the counterweight is carried on the upper and lower counterweight laterals in the same manner as it was carried by counterweight trusses *A* and *B* in the closed position. The distance between panel points in this case is 13 ft. instead of 10 ft. 9 in. and the layout and stresses are illustrated in Fig. 89.

As these are practically the same as for counterweight trusses *A* and *B* the same sections will be used.

The strut down the center will very likely be used to support the forms for the counterweight during construction and so may arbitrarily be made of two angles, $8 \times 6 \times \frac{3}{8}$ in. for safety's sake.

32. Miscellaneous Parts of the Moving Leaf.—Several minor portions of the moving leaf are not yet taken care of. The rack plates which connect

the machinery to the truss and the trunnion plates which must be built up of sufficient thickness of metal to bring the bearing on the trunnion inside the allowable are the heaviest of these miscellaneous items. The rack plates are made of $\frac{1}{2}$ -in. material and extend from *M8-L9* and *U7-M8* toward the trunnion far enough to allow the cast steel rack to be bolted between them.

The brackets on the *L9-U9* posts which engage the anchor columns are usually cast steel and riveted to the post in the larger bridges. In this design, it will doubtless be cheaper on account of the low stress involved to build up a structural bracket, the only designing required being to see that sufficient rivets are provided to stand the full reaction and the 40 per cent impact allowance.

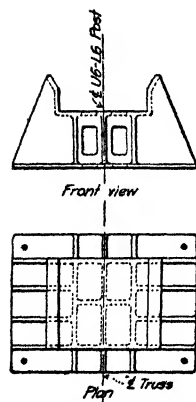

FIG. 90.

The shoe at the bottom of the *L6* post which supports the live load reaction is of somewhat the same nature, the only designing to be done being in the nature of providing a safe connection to the truss. It must, however, be strong enough to withstand its share of the lateral force due to wind. This wind force is not usually serious on the moving portion of the shoe, but in the base on which the shoe rests, provision must be made to prevent the truss being moved laterally off its support. For this reason, the live load shoe at *L6* has two sides extending upward and flared out at their upper edges to catch the descending shoe and guide it to place and then prevent its lateral movement.

These sides should be made considerably stronger than called for by wind forces because they will be called into play in case of a collision between a boat and the bridge and in such a contingency will throw the

loads into the counterweight end of the truss and relieve the strain which would otherwise come on the trunnions and their bearings. A sketch of this base is shown in Fig. 90. The upper and lower bearing plates are rounded in the longitudinal direction in order to insure a seating near the center and not at one edge as would perhaps be the case if plane surfaces were to be used.

33. Fixed Part.—The “fixed part” consists of all that portion that is supported by the pier, but does not move in the operation of the span. The main items of design are: Floor stringers, columns on trunnion girder, main trunnion girder and grillage braces.

These are all illustrated in Fig. 91 and will be taken up in the order given.

33a. Floor Slab.—The stringers will be spaced as shown in Fig. 94.

Consider one rear wheel of the 15-ton truck in the center of the panel and neglect continuity of the slab. The dead load will be say 100 lb. per sq. ft. for the slab plus about 40 lb. per sq. ft. for paving, making a total of 140 lb. per sq. ft. The live load of the wheel will be distributed over an area of 3 ft. 4 in. square when the wheel is considered as having 2- X 2-ft. contact area and the lines of distribution running downwards at 45 deg. through the assumed 8-in. thickness of slab (see Fig. 92).

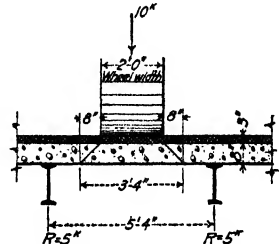

FIG. 92.

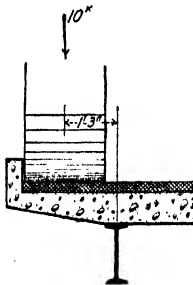
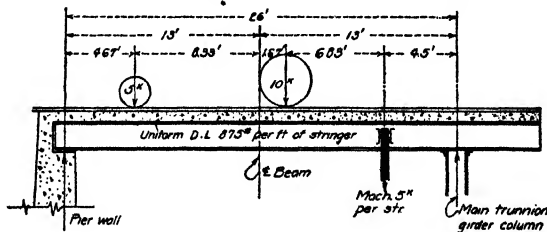

FIG. 93.

The overhanging portion of the slab is shown in Fig. 93, the outer truck wheel being assumed as lying 1 ft. 3 in. from the outer stringer.

With the above loading, the slab is designed by means of the ordinary formulas for reinforced concrete beams. The application of these formulas indicates an area of steel per ft. of slab of 0.57 sq. in. for the interior and 0.62 sq. in. for the overhang.



Loading for Fixed Part Stringer

FIG. 94.

For the sake of simplicity, the whole slab will be made 8 in. thick with 5/8-in. squares on 7-in. centers, placing the center of the steel 1 1/4-in. above the bottom of the slab and having alternate bent-up and straight bars in

order to provide for the shear. This will leave the bars in the top side of the overhang on 14-in. centers and short stubs will have to be placed in between these to make up the required area. These stubs should extend back beyond the first stringer a distance sufficient to develop the bar in bond, or say 40 diameters for a square bar at an allowable bond stress of 100 lb. per sq. in.

33b. Stringers.—The span of the stringers will be from the rear wall of the pier to the columns on the main trunnion girder, a distance of 26 ft. approximately. The distance between axles on the truck is 10 ft. The center of gravity of the two wheels is 3.33 ft. from the large wheel. The placing for maximum live load moment is with the large wheel 1.67 ft. across the center line from the small one. The dead load at 150 lb. per sq. ft. for slab and paving gives $(5.33)(150) = 800$ lb. per ft. of stringer. Assume the weight of the stringer at 75 lb. per lin. ft. and the complete loading diagram is as shown in Fig. 94. The 5,000-lb. machinery load is obtained from the design of the machinery which gave 20,000 lb. to be supported on the four stringers at 4.5 ft. from the center of the main girder.

Moments are as follows under the large wheel: Dead load moment = $(875)(13)(11.33) - \frac{(875)(11.33)^2}{2} = 128,800 - 56,400 = 72,400$ ft.-lb.

Live load moment = 74,300 ft.-lb.

Impact allowance = $(74,300)(0.60) = 44,400$ ft.-lb.

Moment of machinery = $\frac{(4.5)(5)}{26} (21.5) = 18,600$ ft.-lb.

Total design moment = $72,400 + 74,300 + 44,400 + 18,600 = 209,700$ ft.-lb. = 2,518,000 in.-lb. This requires a stringer having a section modulus of $\frac{2,518,000}{16,000} = 159$, which is furnished by a 24-in.

Bethlehem section at 73 lb. per ft.

As the overhang ahead of the center line of the trunnion girder is only 4 ft. 8 in., the same 24-in. Bethlehem beam at 73 lb. will be amply strong.

From the design of the machinery, we find that with the bridge in the open position and the full 15-lb. per sq. ft. wind load on the upraised leaf, there is a load of 24,000 lb. on each of the stringers at the point of connection of the hangers for the machinery floor. The moments at this point would be D.L. of $(875)(13)(4.5) - \frac{(875)(4.5)^2}{2} +$ L.L. of $\frac{(24,000)(21.5)}{26} (4.5) = 51,300 - 8,850 + 89,400 = 131,850$ ft.-lb., which

is considerably less than the live load condition with the bridge closed.

33c. Columns on Main Girder.—Referring to Fig. 95, the truck placing for maximum load is shown.

For the sake of simplicity, the large wheel is placed within 0.7 ft. of the edge instead of 1 ft. The moments about the left-hand support to give the reaction on the column are as follows:

Dead load (0.875)(30.7)(30.7)(0.5)	= 415
Machinery hanger (5)(21.5)	= 108
Live load (15)(26.7)	= 400
Impact (15)(26.7)(0.3)	= 120
Total moment	= 1,043 kip-ft.

$R_2 = 1,043 \div 26 = 40$ kips, which is the maximum reaction on the column.

Assume a Bethlehem I-beam 18 in. wide so that the flanges of the beam may rest over the webs of the girder.

The 18-in. Bethlehem-I at 48.5 lb. has a radius of gyration of 1.59.

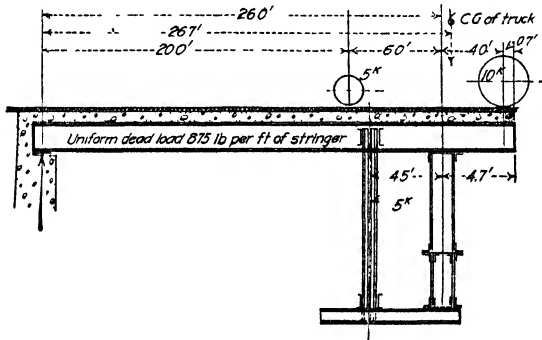

FIG. 95.

$16,000 - 70L/R = 16,000 - (70)\left(\frac{77}{1.59}\right) = 12,620$ lb. per sq. in. The area of the section is 14.25 sq. in. which is readily seen to be more than ample for strength.

33d. Main Trunnion Girder.—For calculating the loads on the main girder, the weight of the trunnion bearings is taken as 3,000 lb. each. The trunnions are estimated at 1,400 lb. each, or 700 lb. per bearing. From Fig. 75, the load of the truss is 403,000 lb. or 201,500 on each bearing, making a total at each trunnion bearing of 205.2 kips. The load from the columns under the fixed part is 40 kips at each post as just determined. The girder is symmetrical about the center line and will be assumed to weigh 800 lb. per lin. ft. The loadings and the shear and moment diagrams are shown in Fig. 96 from which the maximum moment is seen to be 24,578,400 in.-lb. The depth of the girder is determined by the available space between panel point *T* and the lower chord *L6-L8*. The center line distance is 7 ft. 3 in. (see Fig. 73).

The half depth of L6-L8 (from the same figure) is $9\frac{1}{8}$ in. plus the lacing and rivets, or say 10 in. all told. This leaves 6 ft. 5 in. from *T* to clearance. The trunnion bearing will be about 30 in. from the center of the trunnion to the base and, allowing 1 in. for bearing plates, gives another 31 in. to subtract from the 6 ft. 5 in. The arc through which the lower chord swings when opening will take off another $1\frac{1}{2}$ in., leaving 3 ft. $8\frac{1}{2}$ in. without considering any lower cover plate. Allow $\frac{1}{2}$ in. for this and make the girder about 3 ft. 8 in. deep from out to out. A

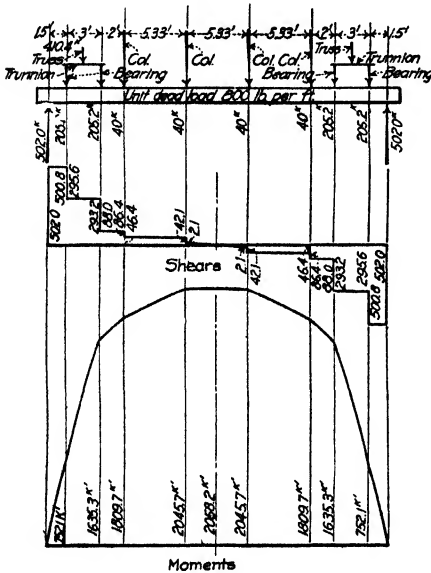

FIG. 96.

rough calculation shows about 42 in. as the required area of flange. Allowing 8 in. for holes will give the make-up as shown in Fig. 97.

Next find the center of gravity of the two flanges considering $\frac{1}{8}$ of the web as flange. This is done in the ordinary manner and needs no explanation. The results are as follows:

The distance from the back of the lower flange angle to the center of gravity of the lower flange is $\frac{212.35}{49.84} = 4.25$ in., and the distance to the center of gravity of the upper flange is $\frac{162.55}{54.84} = 2.97$ in. as shown in Fig. 97.

The distance between center of gravity of the flanges is, therefore, $3 \text{ ft. } 7\frac{7}{8} \text{ in.} - (2.97 + 4.25) = 36.65 \text{ in.}$

The required tension area is $\frac{24,578,400}{(16,000)(36.65)} = 41.8 \text{ sq. in.}$

The gross area of the bottom flange is 59.84, leaving 8.04 sq. in. which can be taken out as holes for rivets.

Referring again to Fig. 91 there is at the center one hole through both side plates, the flange angle, and the web, and one hole through the flange plates and the web. The total distance through all this metal is $(2)(\frac{5}{8}) + 1\frac{1}{16} + \frac{3}{8} + (2)(\frac{5}{8}) + \frac{3}{8} = 3\frac{9}{16} \text{ in.}$

This is the same for the other web and makes a total area of 7.125 sq. in. If a lacing angle were so placed that an additional rivet hole were taken out of the effective section, the total holes out would be 8.50 sq. in., leaving 41.34 sq. in. net as against a required area of 41.80.

At the ends, the shear is so great as to require the addition of extra web plates to build the shear section up to a gross area of $50\frac{2}{10} = 50.2 \text{ sq.}$

in. The main webs are two $43 \times \frac{3}{8}$ plates giving an area of 32.25. Ample shear area will be provided by placing one $43 \times \frac{5}{16}$ -in. plate inside each of the other web plates at the ends and extending them out beyond the inside trunnion bearing.

The other details of the girder such as rivet pitch, stiffeners, fillers, etc., do not differ from the details of any other similar member and need no mention here.

33e. Grillage Braces.—The one other item in connection with the fixed part that is different from ordinary fixed span work is the anchorage of the ends of the main girder to prevent overturning with the leaf up during a high wind. This wind will give a horizontal force of 110,000 lb. at the trunnion. Considering a layout, as in Fig. 98, the

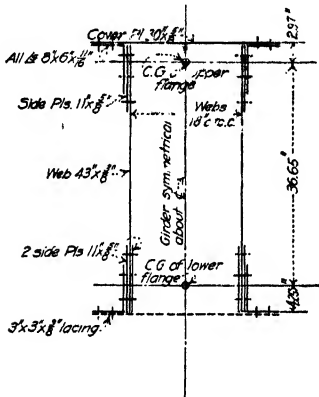

FIG. 97.

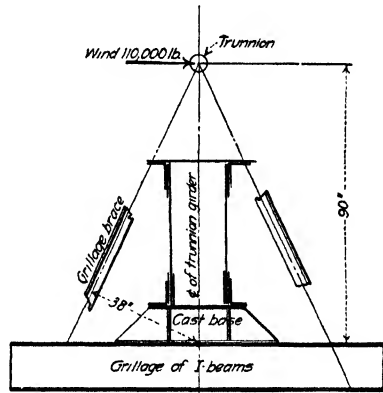

FIG. 98.

stress on the brace will be $\frac{(110)(90)}{38} = 260$ kips. As this is a wind load, a unit stress of 20,000 lb. per sq. in. is allowable, which makes the net area required 13.0 sq. in.

This is furnished by four angles, $5 \times 5 \times \frac{1}{2}$ -in. riveted at the top to the stiffeners on the girder and at the bottom to the I-beam grillage which in turn is to be concreted solidly into the body of the pier.

The holding down bolts which fasten the trunnion bearings to the girder must also resist the overturning due to the wind.

The vertical arm of the wind force is 30 in. The distance between bolt holes in the two sides of the bearing is approximately 32 in. which makes the stress on each of the four bolts at one end of the girder equal to 25,800 lb. They will, therefore, need $\frac{25,800}{20,000} = 1.29$ sq. in. each in cross-section. These, however, are part of the machinery design and as there are other factors entering into their design they will not be discussed further here.

34. Counterweight Calculations and Methods of Balancing Span.—

Having the structural portion of the moving leaf designed and detailed, it becomes necessary to calculate the weight and center of gravity of each of the members of the moving portion and then, taking the moment of all of the moving parts about the trunnion, to determine the amount of counterweight necessary to cause the span to be balanced in all positions.

Horizontal moments ("X" moments) are taken about a vertical line YY, through the trunnion in order to determine the *amount* of concrete to put into the counterweight. Vertical moments ("Y" moments) are taken about a horizontal line, XX, through the trunnion in order to determine the *location in a vertical direction* of the center of gravity of the mass of concrete whose weight was determined by the first set of moments.

These calculations for counterweight are made from the shop drawings and the weights obtained in the calculations carefully checked against the shipping weight of the material to guard against error.

In the sample calculations shown at the end of this chapter, the distance to each part of each member was taken from the trunnion direct. It is usually customary on large or complicated work to take the center of gravity of each part with reference to some panel point on the member and after the weight and center of gravity of the individual members are found, then to calculate the distance X and Y from the trunnion for each member and make a summary sheet showing the moments of the different members. In small or simple work, much time can be saved by taking all moments about the trunnion in the first place, then in making the summary sheet no recalculation is necessary, the only process being that of listing and summing up all the sub-totals from the itemized calculation sheets.

After the total weight and center of gravity have been found and listed it is a very simple matter to add or subtract parts of the work or make alterations in the work as detailed. In order to illustrate this, a sheet of calculations for the floor are included in the sample calculations herewith appended, as the floor in this particular case was originally intended to be 3½ in. of wood block on a 2 × 6 laminated deck and was afterward changed to 2 in. of asphalt on a 2 × 8 laminated deck with an attendant increase in weight of 11,350 lb.

In the accompanying tables of calculations, only such sheets as are necessary to convey the idea are given. Their original numbers are preserved, however, in order to indicate clearly that the calculations are not all included.

In taking off the material from the shop details, it is a very easy matter to list main material and details separately and to do the same again in a summary sheet so that the percentage of details can be determined for use in future estimating. Sheets 1, 2, 3 and 4 are sufficient to show the make-up of the sheets which has proved most satisfactory and to show also that every item is considered.

The weights are for one truss and are multiplied in the summary. As the center lock machinery is all on one leaf, the two leaves must be kept separate, calculations being made for one and corrections made in that final result to care for the differences in the other. The north leaf was taken in this case and the right-hand girder considered, as is shown by the notation *N.G.R. U1* on the first line of the first member. The number 2 indicates that two trusses will be taken in the summary. The notation "material for one girder on north leaf—multiply this sheet by 4" refers to the factor to apply to the sheet to obtain the total steel in the structure for the purposes of payment. Also in the upper right-hand corner is a notation *L1* showing on which shop drawing the details of the piece will be found.

Some of the members lie wholly within one quadrant and as a result, the moments will be all of one sign. This is true of the material on sheets 1, 2 and 3. In the upper left-hand corner is a notation to that effect. Moments toward the center of the river or above the horizontal through the trunnion are plus. Those below the horizontal through the trunnion or toward the shore are minus.

The calculation for floorbeams 1 and 2 are given on sheet 25.

Sheet 29 gives a set of stringer calculations and sheet 30 gives the calculations for the floor weights together with the correction for the change in the floor design mentioned above.

Sheet 31 shows the calculations for the weights of machinery appertaining to the center lock. Sheet 11 shows part of the counterweight end and illustrates the distinction between plus and minus.

The totals of the itemized sheets are multiplied by the number of pieces per leaf and listed on sheet 39 with their total moments, both plus and minus, about the trunnion. For instance, on sheet 1, the weight of girder *U1-U2-U3* for the right-hand truss on the north leaf is given as 6,719.66 lb. of main material and 2,901.87 lb. of details, making a total weight per truss of 9,621.53, with moments of 661,214 horizontal and 42,235 vertical. There are two of these pieces in the leaf so the totals on sheet 31 will show just double the amount which appears on sheets 1 and 2 of the calculations.

In the left-hand column of sheet 39 are listed the shop detail sheets from which the weights are taken together with the number by which the sheet weight must be multiplied to obtain the weight per leaf.

These weights and their moments are summed up at the bottom to give the total weight of all moving parts except the counterweight.

At this time, the change in the design of the floor system was made and the correction to add to the weights and moments calculated and listed on sheet 30.

The totals for sheet 39 are now listed on sheet 47 and the correction from sheet 30 added.

In the original calculation for counterweight details the weight of the counterweight concrete was assumed at 142 lb. per cu. ft. When construction started, test blocks containing 8 cu. ft. of the proposed counterweight concrete mixture were made and weighed from time to time to obtain as closely as possible a figure to use in the final balance computations. These test blocks indicated that the weight of the finished counterweight would be 147 lb. per cu. ft. for the plain concrete, to which must be added the increase due to the addition of reinforcing bars. The plans call for the reinforcement to be 1-in. square bars, 12-in. on centers, all three ways. This gives 36 cu. in. of steel, weighing 10.26 lb., which will replace 36 cu. in. of concrete weighing 3.07 lb., making a net increase in weight of 7.19 lb. per cu. ft. The weight of the counterweight will then be 154.19 lb. per cu. ft.

Volume Occupied by Structural Steel.—As the counterweight concrete is built on and around the structural frame of the trusses, there will be certain parts of the structural steel which will be surrounded by the concrete.

The weight of this steel having been included in the calculations, its volume must be subtracted from the total volume of the counterweight.

The usual method of caring for this is to consider a transverse distance from face to face of counterweight enough different from the actual to allow for this extra concrete.

Sheet 46 shows the calculations for concrete displaced by structural steel. Those parts which are only partially embedded (as, for instance, lower chord *L6-L9* which is only covered from *L9* to *L8*) are listed piece by piece. Such items as the counterweight cross frames which are wholly embedded may be taken from the itemized weight sheets.

The total weight of embedded steel is calculated and then divided by 490 to obtain the volume of displaced concrete.

Actual Location of Center of Gravity of Entire Leaf.—In the itemized lists and the summary, all moments are taken about the center of the trunnion. In all discussions also, it is customary to speak of the leaf as being in perfect balance about the center of the trunnion. This is a condition of counterweighting that can be computed very readily, but is neither desirable nor easily obtainable in actual construction. As was explained in the chapter on design, the actual center of gravity of the entire moving load should be on a line through the center of the trunnion making an angle ahead of the trunnion with the vertical of one-half the angle of opening and far enough from the center of the trunnion on this line to cause a forward moment equal to the friction of the trunnion bearings under full load. This friction is usually assumed at 15 per cent. This gives the distance ahead of the vertical to which to bring the actual center of gravity of the entire leaf as 15 per cent of the trunnion radius. It is not desirable to work as close as this in small structures, however,

and so when the diameter of the trunnion is less than 18 or 20 in., the actual center of gravity of the moving leaf should be placed about 2 in. from the center of the trunnion. This was done in this case and the coordinates of the actual location from the center of the trunnion are $+0.09$ ft. = x and $+0.135 = y$.

Referring to sheet 47 again, after the corrected weights and moments are calculated, the location of the center of gravity of all the moving leaf except the concrete is obtained by dividing the moments by the weights. This is found to be 27.45 ft. ahead of, and 2.54 ft. above, the trunnion. As it is desired to bring the center of total weight to a point 0.09 ahead of, and 0.135 ft. above, the trunnion, the coordinates of the point just found will be $27.45 - 0.09 = 27.36$ ft., and $2.54 - 0.135 = 2.41$ ft.

The weight of 313,995 times these new lever arms gives the X and Y moments for the actual counterweight.

As the distance from the center of the trunnion to the center line of the counterweight is 17.50 ft., the distance from the new location of the center of gravity will be $17.50 + 0.09 = 17.59$.

The weight of concrete required is found to be 488,396 lb. which at 154.19 lb. per cu. ft. will occupy a volume of 3,167 cu. ft. The horizontal distance from the actual center of gravity of the moving leaf to the center line of the counterweight is easily maintained. The location of the center of gravity of the counterweight in any predetermined point in a vertical direction is a problem of arranging a system of galleries and pockets in a fixed end area and a fixed length between trusses.

The distance to subtract from the transverse width of the counterweight on account of the embedded steel is 67 divided by the end area of the equivalent solid mass. The end height is $\frac{3,167}{(25.33)(14)} = 8.95$ ft.

The distance to subtract is then $\frac{67}{(8.95)(14)} = 0.53$ ft., leaving 24.8 ft. as the figure to use in calculating the space to be filled with concrete. On the basis of a length of 24.8, it requires 9.15 ft. of depth to give 3,167 cu. ft. of concrete.

The amount of concrete to be placed as permanent counterweight is only 97.5 per cent of the total on account of the necessity of leaving $2\frac{1}{2}$ per cent of the space to use for changes in the counterweight due to seasonal variation in the weight of the overhanging leaf. This gives the height of the equivalent solid mass of concrete as 8.88 ft. and the volume as 3,088 cu. ft. as shown at the top of sheet 48.

The center of gravity of the 100 per cent mass must be 1.549 ft. below the actual center of the total moving load, or 1.41 ft. below the center of the trunnion.

To insure this condition, the counterweight is roughly laid out to show a 12-in. floor in the galleries that are to hold the balance blocks which go

to make up the $2\frac{1}{2}$ per cent. The extreme lower edge of the counterweight is placed 12 in. below the center line of the bottom chord in order to allow for approximately $2\frac{1}{2}$ in. of cover over the steel. The balance blocks will then rest on a floor which is 7 ft. 3 in. below the center of the trunnion or $7.25 - 1.41 = 5.84$ ft. below the desired center of gravity of the 100 per cent counterweight.

Two and one-half per cent. of the 3,167 cu. ft. of counterweight is 79 cu. ft. If the gallery is 3 ft. wide, a double layer of blocks need only be 13 ft. long in the center of the counterweight to make the required weight.

Taking out these blocks would lighten the lower portion of the counterweight and allow the center of gravity to rise 0.11 ft., leaving the center of gravity of the 97.5 per cent counterweight, 1.30 ft. below the center line of the trunnion. Measuring from a point 12 in. below the center line of the bottom chord to the under side of the fixed part stringers gives a depth of 12 ft. 2 in. in which to put the counterweight. As some clearance must be left, the depth of the counterweight will be assumed as 11 ft. 9 in., as shown on sheet 48.

The problem now is to so distribute 3,088 cu. ft. of concrete in a space 24.8 ft. \times 11 ft. 9 in. \times 14 ft. 0 in. that there will be pockets and galleries accessible for placing balance blocks and also that the center of gravity of the completed mass will fall 6.94 ft. above the base, without balance blocks, and 6.83 ft. above the base after the $2\frac{1}{2}$ per cent of balance blocks are placed.

Referring now to sheet 49: The total space occupied by the counterweight is $(24.8)(14.0)(11.75) = 4,079.6$ cu. ft. As it is necessary to concentrate the load in the top of the space, the portion above the center of gravity will not have any openings and can be left solid. This is $(24.8)(14)(4.81)$ or say 1,670 cu. ft., leaving 2,409 cu. ft. in the lower portion. Considering moments about the 97.5 per cent center of gravity gives 4,025 above the center of gravity and 8,359 below (the units being cubic feet times lineal feet instead of weight times feet to save changing volume into weight and back again).

The passage down the center (see sketch on sheet 49) was to be 3 ft. wide. The total length will, of course, be 24.8 ft., but as the two entrances are over the lower chords, 2 ft. 4 in. is taken off each end and the reduced portion figured separately. The length is then 24.8 less two sections 2 ft. 4 in. = 20.14 ft. Making the height 5 ft., and remembering that the bottom of the passage is on the line of the bottom chord, gives a distance to the center of gravity of this passage of 3.44, and a moment of the subtracted portion of 1,039. The total volume left is 3,777 cu. ft. and the moments are 7,320 below and 4,025 above the center of gravity. Taking the two doors to the passage (one at each truss) as 4 ft. high and 3 ft. wide gives 56 cu. ft. and 165 lower moment to take off, leaving 3,721 cu. ft. and 7,155 moment.

In like manner four holes, $3\frac{1}{2} \times 4 \times 1$ ft. are placed in the bottom of the mass symmetrically about both the longitudinal and transverse center lines of the counterweight, taking out 56 cu. ft. and a moment of 361. Directly over these the openings are lengthened out to 9.5 ft. and run up 5 ft. further, making four openings $3.5 \times 5 \times 9.5$ ft., taking away 665 cu. ft. and a moment of 2,228, and leaving the volume of concrete 88 cu. ft. less than the required, but with the moment still higher than that of the upper mass. The problem is now to *add* 88 cu. ft. in such a position that it will increase the moment of the upper portion. This is accomplished by placing a slab on top of the counterweight between the stringers.

The distance to the center of gravity of this added block must be $\frac{(4,506-4,025)}{88} = 5.45$ ft. The distance from the center of moments to the top of the 11 ft. 9 in. mass is 4.81 ft. which leaves 0.64 ft. as half the depth of the blocks, or about 1 ft. 3 in. as the total depth.

A machinery bracket comes across between the stringers about 1.5 ft. back of the forward line of the counterweight and allowing 1-ft. clearance at the back gives 11 ft. as the length of the block. The width is $\frac{88}{(11)(1.28)} = 6.33$ ft.

If it is desired, this 6.33 ft. can be divided and the separate blocks placed between other stringers without disturbing the balance.

OFFICE OF BRIDGE ENGINEER
OREGON STATE HIGHWAY COMMISSION
SALEM, OREGON

Made by J.A.W. Date July 25, 1920
Checked by O.G.A. Date Aug 14, 1920
Backchecked J.A.W. Date Aug 30, 1920

Assignment No. 43
Bridge No. 330
Sheet No. 1 of 1 Sheets

All moments are **TRUSS**

Calculations for **Weights & C. G. YOUNG'S. BAY BASCULE BRIDGE-(North Leaf) DWG. L1**

No. Pcs.	Material	Length	Wt./Ft.	Total Weight	+x from Trussion	+x from Trussion	+x Momt.	-x Momt.	+Y Momt.	-Y Momt.
Material for I-Girder on North Leaf - (North leaf has 2-Girders like this - Bridge has 2 Leaves) <i>Multiply this sheet by 2</i>										
NGR-U17	1/2 5x5x3/8	16.60	12.3	408.36	+78.47	+7.40	324.52			30.21
n 2	1/2 5x5x3/8	15.63	12.3	384.50	+78.98	+6.10	303.68			23.45
L1 2	1/2 5x5x3/8	15.66	12.3	385.24	+79.-	+3.20	304.33			12.32
n 2	1/2 5x5x3/8	16.58	12.3	407.86	+79.46	+1.90	324.08			7.78
U2 2	1/2 5x5x7/16	15.60	14.3	446.16	+63.30	+7.40	282.41			33.01
n 2	1/2 5x5x7/16	15.35	14.3	439.02	+62.36	+6.10	278.16			26.78
L2 2	1/2 5x5x7/16	15.35	14.3	439.02	+63.49	+2.40	278.73			10.58
n 2	1/2 5x5x7/16	15.70	14.3	449.02	+63.35	+1.10	284.45			4.94
U1 1	PL 72x7/16x18.81A	107.02	12.75	1364.51	+78.25	+4.62	1067.73			63.04
U2 2	n 84x7/16x18.81A	88.60	12.75	1129.65	+62.16	+4.18	702.19			47.22
L2 2	n 8x7/2x16.5		13.60	448.80	+64.06	+6.75	287.52			80.29
L2 2	n 8x7/2x15.35		13.60	417.52	+63.35	+1.74	264.50			7.26
Total Main Material				6719.66						
U1 2	1/2 4x4x3/8	5.44	9.8	106.62	+87.66	+4.75	93.46			5.06
1	1/2 4x4x3/8	5.46	9.8	53.50	+86.92	+4.75	46.50			2.58
1	1/2 6x4x1/2	5.46	16.2	88.45	+86.92	+4.75	76.88			4.20
2	1/2 4x3x3/8	2.62	8.5	44.54	+81.08	+4.73	36.11			2.10
2	1/2 4x3x3/8	2.75	8.5	46.76	+76.08	+4.63	35.58			2.16
1	1/2 4x4x3/8	2.83	9.8	27.73	+71.29	+4.55	19.77			1.26
1	1/2 6x4x1/2	2.87	16.2	46.49	+71.35	+4.55	33.17			1.85
U2 2	1/2 4x3x3/8	3.29	8.5	54.40	+66.08	+4.35	35.35			2.37
2	1/2 4x3x3/8	3.66	8.5	62.22	+61.08	+4.17	38.00			2.59
2	1/2 5x3x3/8	6.17	9.8	120.94	+55.56	+3.95	67.19			4.77
U1 2	Fills 4x3/8x466 Lift @	5.10		47.54	+87.66	+4.75	41.67			2.26
2	" 4x3/8x466 n @	5.10		47.54	+86.92	+4.75	41.32			2.26
NG	1/2 2x3/8x1.5 n @	7.02		10.53	+87.29	+4.75	9.19			.50
NG only 1	1/2 6x3/8x1.5 n @	15.3		22.95	+86.47	+4.75	19.84			1.09
U2 2	PL 72x7/2x3.54 A=5.10 @2040			208.09	+70.51	6.75	146.72			14.05
L2 2	" 18x7/2x3.25 A=4.50 @2040			183.60	+70.17	2.30	128.83			4.22
U2 2	" 10x3/8x2.98 Lift @	12.75		76.00	+69.17	4.55	52.57			3.46
U2 1	" 10x3/8x1.70 "	@	11.85	30.36	+71.17	7.53	21.61			2.30
U2 2	" 5x7/2x1.79 "	@	8.50	30.44	+71.13	5.97	21.65			1.82
L2 1	" 4x7/2x3.10 "	@	6.80	21.08	+71.17	3.03	15.00			6.4
L2 2	Fills 8x12x.54 "	@	13.60	44.68	+71.46	2.35	10.49			3.4
L2 4	" 4x7/16x.56 "	@	.90	2.00	+71.46	2.85	1.43			.5
L2 4	" 4x7/16x.25 "	@	.90	11.72	+70.17	2.30	8.22			.27
U2 4	" 4x7/16x3.54 "	@	.90	12.76	+70.51	6.75	9.00			.86
U2 4	" 4x7/16x1.12 "	@	.90	4.04	+71.13	6.75	2.90			.27
4	" 4x7/16x0.54 "	@	1.91	4.12	+71.46	2.35	2.94			.10
U3 4	1/2 8x6x3/8	3.0	28.5	342.00	+57.25	6.75	195.93			23.09
n 4	1/2 8x6x3/8	1.5	28.5	171.00	+56.50	6.75	96.62			11.54
L3 4	1/2 8x6x3/8	3.0	28.5	342.00	+57.33	1.15	196.07			3.93
n 4	1/2 8x6x3/8	1.5	28.5	171.00	+56.53	1.15	96.67			1.97
n 1	1/2 7x3/2x1/16	125	15.0	18.75	+56.75	1.90	10.64			.36
2	PL 11x3/4x1.25	@	19.98	49.96	+56.67	6.75	28.31			3.37
Subtotal Details Fwd				2473.80						
Total for 1 Girder-Sheet (1)				9193.46			6342.51			404.55

OFFICE OF BRIDGE ENGINEER
 OREGON STATE HIGHWAY COMMISSION
 SALEM, OREGON

Made by J.A.W. Date July 25, 1920.
 Checked by A.G.B. Date Aug. 14, 1920.
 Rechecked by J.A.W. Date Aug. 30, 1920.

Assignment No. 43
 Bridge No. 330
 Sheet No. 2 of Sheets

All Moments + TRUSS

Calculations for Weight and C.G. Youngs. Bay Bascule (North Leaf). DWG L1

No. Pieces	Material	Length	Wt./ft.	Total Weight	X ² from trussion	Y ²	+X Moment	-X Moment	+Y Moment	-Y Moment
Material for 1 Girder on North leaf (2 Girders per leaf 4 per Bridge)										
Fwd. from Sh #1.				2473.80			6342.51		4045.55	
N.G. U3-1	1 C 15 ¹⁶ 33 ¹⁶	1.50		49.50	55.44	6.75	2744		334	
"	1 C 15 ¹⁶ 33 ¹⁶	2.2		72.60	55.44	1.5	4025		109	
"	2 Fls 2 ¹ / ₂ x 1/2	1.50		12.75	55.40	6.75	707		85	
"	4 Bolts 1 ³ / ₄ x 3 ³ / ₄	Ø	1.32	19.80	55.35	7.30	1096		145	
"	4 Wash 2 ¹ / ₄ x 1/4	Ø	.20	.80	55.35	7.30	44		6	
"	4 Bolts 1 ³ / ₄ x 3 ³ / ₄	Ø	1.32	19.80	55.35	0.57	10.96		11	
"	4 Wash 2 ¹ / ₄ x 1/4	Ø	.20	.80	55.35	0.57	44		-	
428	3/4 Riv Hds. per 100-41.25			61.30	75.-	4.37	45.94		2.68	
U1-22	"	"		3.14	87.29	6.75	274		21	
L1-22	"	"		3.14	87.29	2.75	274		9	
U1-44	"	"		6.27	85.33	6.75	535		42	
L1-44	"	"		6.27	85.33	2.75	535		17	
12	"	"		1.71	81.17	4.75	139		8	
12	"	"		1.71	76.17	4.65	130		8	
22	"	"		3.14	71.50	4.81	225		14	
80	"	"		11.40	69.17	4.50	789		51	
14	"	"		2.00	66.17	4.35	132		9	
16	"	"		2.28	61.17	4.15	139		9	
U2-162	"	"		23.09	70.50	6.75	1628		156	
L2-136	"	"		19.38	70.71	2.35	1360		46	
U3-178	"	"		25.37	57.0	6.75	1416		171	
L3-268	"	"		38.19	58.0	2.15	2215		82	
L1-28	"	"		3.71	85.83	2.00	318		7	
U2-40	"	"		5.70	71.17	7.50	406		43	
U2-40	"	"		5.70	71.17	6.00	406		34	
L2-28	"	"		3.71	71.17	2.00	264		7	
U3-20	"	"		2.85	55.5	6.50	158		19	
L3-36	"	"		5.13	55.5	2.00	285		10	
U3-36	"	"		5.13	57.0	6.75	292		35	
L3-82	"	"		11.69	56.75	2.00	663		23	
Total Details				2901.87			76963		1780	
Total 1 Girder				9621.53			661214		42235	

OFFICE OF BRIDGE ENGINEER
OREGON STATE HIGHWAY COMMISSION
BALHM, OREGON

Made by J.A.W. Date July 26, 1920.
Checked by O.G.A. Date Aug. 16, 1920.
Rechecked by J.A.W. Date Aug. 30, 1920.

Assignment No. 43
Bridge No. 330
Sheet No. 3 of Sheets

All Moments +

TRUSS

Calculations for Weight and C.G. Youngs Bay Bascule (North Leaf) Dwg L2.

No. Pieces	Material	Length	Wt/lf	Total Weight	X ² from trussion	Y ²	+X Moment	-X Moment	+Y Moment	-Y Moment
Material for 1 Girder on North Leaf (2 per leaf - 4 per bridge)										
N.G. - U3-U4 Main Material										
2	15 4x4x3/8	17.48	9.8	342.60	48.55	7.42	166.33			2642
2	16 4x4x1 7/8	17.48	9.8	342.60	48.55	5.90	166.33			2021
2	1 18 x 1/2	17.48	30.60	10.69.70	48.55	6.76	519.38			72.81
Total Main Material				17.68.90						
Top	1	1P 42x1/2	2.08	14.80	55.5	7.51	82.42			1115
Bot.	1	1P 20x1/2	2.08	34.00	70.72	5.97	39.06			4.22
"	1	1P 20x1/2	2.08	"	70.72	45.01	5.97			4.22
Side	2	2 Fills 18x1/4	3.96	15.30	121.18	41.83	6.75			818
Top	14	1 L.B. 2 1/4 x 3/8	2.81	4.78	182.02	47.42	7.51			1412
Bot.	8	" 2 1/4 x 3/8	2.81	"	107.44	49.44	5.97			641
Side U3 U4 Riv. Hds. per 100										
Top U3	52	"	"	14.25	18.81	56.40	6.75			127
"	L.B. 46	"	"	"	"	7.41	55.5	7.51		56
Bot U3	8	"	"	"	1.14	55.5	5.97			7
"	1P 20	"	"	"	2.85	53.82	5.97			17
"	1P 20	"	"	"	2.85	45.01	5.97			17
"	L.B. 20	"	"	"	2.85	49.44	5.97			17
Total Details				749.04						
Total Member				2504.04			122002			16304
N.G. U4-U5 Main Material										
2	15 4x4x3/8	15.67	9.8	307.14	+ 32 -	+ 7.42	9829			2277
2	16 4x4x3/8	15.67	"	307.14	32 -	6.90	9829			1868
4	1 18 x 3/8	15.67	22.95	14.59.32	32 -	6.75	4.60.33			9710
Total Main Material				2052.80						
Top U4	1	1P 24x1/2	2.08	40.80	24.86	39.83	7.51			637
"	1	1P 12x1/2	2.08	30.40	42.43	31.25	7.51			319
Bot U4	2	1P 3x1/2	2.08	5.10	24.62	39.83	5.97			147
"	1	1P 20x1/2	2.08	34.00	70.72	37.37	5.97			4.22
"	1	1P 20x1/2	2.08	"	70.72	78.30	5.97			4.22
Side U4	2	2 Fills 16x1/2	2.75	27.20	149.60	40.08	6.75			1010
"	2	2 Fills 10x3/8	2.75	12.75	70.12	40.08	6.75			473
"	U5 2	" 18x1/8	2.79	7.65	42.68	25.56	6.75			288
Gusset U4 2	1P 4x4x1/2 x 5/2	A=15.31	20.40	624.64	41.08	6.00	256.60			3748
Top	8	L.B. 2 1/2 x 3/8	2.81	5.31	119.36	35.29	7.51			698
"	6	L.B. "	"	"	89.52	28.13	7.51			672
Bot.	8	L.B. "	"	"	119.36	32.67	5.97			718
Top U4 Riv. Hds. per 100										
Top U4	32	"	"	21.25	6.80	39.83	7.51			51
"	16	"	"	"	3.40	31.25	7.51			26
"	L.B. 20	"	"	"	4.25	35.29	7.51			32
"	18	"	"	"	3.82	28.13	7.51			29
Bot U4	32	"	"	"	6.80	39.83	5.97			41
"	20	"	"	"	4.25	37.37	5.97			25
"	20	"	"	"	4.25	28.20	5.97			26
"	L.B. 20	"	"	"	4.25	37.67	5.97			25
Side U4-500	"	"	"	"	63.75	39.83	6.75			430
"	U5 32	"	"	"	6.80	28.60	6.75			46
"	U4 4	Bot 7/8 x 2	"	101	4.04	42.20	6.75			27
"	U5 4	" 7/8 x 2	"	101	4.04	25.56	6.75			27
Total Details				1625.14						
TOTAL MEMBER				3677.94			126539			24387

OFFICE OF BRIDGE ENGINEER
 OREGON STATE HIGHWAY COMMISSION
 SALEM, OREGON

Made by J. A. W. Date July 27, 1920
 Checked by O. G. B. Date Aug. 17, 1920
 Backchecked J. A. W. Date Aug. 30, 1920

Assignment No. 43
 Bridge No. 330
 Sheet No. 4 of Sheets

TRUSS

Calculations for Weight and C.G. Youngs. Bay Bascule (North Leaf) DWG L2

No. Pieces	Material	Length	Wt./ft.	Total Weight	XI from truss center	Yt from truss center	+X Moment	-X Moment	+Y Moment	-Y Moment
Material for I Girder on North leaf (2 Per leaf - 4 per bridge)										
L3-L4 Main Material										
2	1/2 3"x3"x3/16	17.75	7.2	253.50	+48.70	-0.52	124.48			132
2	1/2 3"x3"x3/16	17.62	"	253.77	+48.68	+0.82	123.41		2.08	
2	IP 18x1/2	15.83	30.60	968.79	+47.66	+0.16	411.72			1.66
2	IP 18x1/2	1.92	"	117.50	+56.82	+1.22	66.88			143
2	IP 10x1/2	15.83	17.0	528.00	+47.60	+0.16	256.00			86
Total Main Material				2133.61						
Details										
Sick L3	2 IP 10x1/2	4.15	30.60	232.56	55.00	+1.10	128.84			2.56
	2 IP 10x1/2	1.83	17.00	64.26	36.42	1.22	36.26			78
	2 Filw 3x3/16	1.87	1.8	7.14	56.82	1.81	4.03			13
	2 " "	1.87	"	7.14	56.82	0.65	4.03			5
	2 " "	2.24	"	8.56	85.38	1.56	4.66			13
	2 " "	2.24	"	8.56	54.39	0.40	4.65			3
	2 " "	1.48	"	5.66	2.58	-0.18	2.30			1
	2 " "	1.48	"	5.66	48.52	-1.35	2.30			0
Gusset 2	IP 32x1/2x5.21'A-11.46"	20.00		467.56	54.60	+1.42	255.28			664
Top L3-4	1 IP 20x1/2	2-	34.0	68.00	47.48	+0.30	28.85			20
"	1 IP "	2-	"	68.00	51.0	+1.61	34.68			96
Bot L3-4	1 IP "	2-	"	68.00	53.08	+0.05	36.09			3
"	1 IP "	2-	"	68.00	42.00	-1.00	28.56			68
	1 Strap 3x1/2	2.85	5.10	14.54	39.83	0.10	5.79			1
Top L3-4	8 L.B. 2"x4"x1/8	2.69	4.70	102.88	46.83	+0.83	48.18			85
Bot "	10 L.B. "	"	"	128.60	47.90	-0.66	61.59			85
Cover	240 3/4" Riv Hds.	per 100	14.25	34.20	34.50	-0.29	12.13			9
Side L3-4	100 "	"	"	58.14	55.5	+1.08	32.27			28
I.B.	120 "	"	"	17.10	55.5	+1.15	9.49			22
	120 "	"	"	14.25	51.25	+0.66	7.30			9
Side L4	176 "	"	"	25.08	42.83	-0.50	10.62			13
Top L.B.	20 "	"	"	2.85	46.83	+0.83	1.38			2
Bot L.B.	34 "	"	"	4.85	46.82	-0.77	2.28			4
L3	4 Bolts 3/4x2 1/2	"	74.0	2.98	56.60	+1.16	1.88			3
	4 3/4x2	"	67.0	2.69	53.50	+1.30	1.43			5
	2 3/4x1 3/4	"	64.0	1.28	40.66	-1.42	5.2			2
	4 3/4x2 1/2	"	74.0	2.90	40.88	-0.83	1.70			2
Total Details				1491.47						
TOTAL MEMBER				3625.08			1748.51		1898	325

OFFICE OF BRIDGE ENGINEER
 OREGON STATE HIGHWAY COMMISSION
 BALDAM, OREGON

Made by J.A.W. Date July 30, 1920.
 Checked by O.G.A. Date Aug 26, 1920.
 Rechecked by J.A.W. Date Aug 28, 1920.

Assignment No. 43
 Bridge No. 330
 Sheet No. 11 of 11 sheets

Add Sheets 11 and 12 for Shipping Weights.
 Calculations for Weights and C.G. Youngs Bay Bascule (North Leaf) Dwg. L4.

No. Pieces	Material	Length	Wt/lb	Total Weight	X ± from truss line	Y ± from truss line	+X Moment	-X Moment	+Y Moment	-Y Moment
N.G. U7-U9 Main Material. (Incl. M8-U9) (2 per leaf- 4 per bridge)										
2	15 5/8" x 3 1/2"	5.38	12.8	137.72	- 3.97	+ 6.97			5.40	9.53
2	"	4.87	"	124.68	- 4.17	+ 6.65			5.20	8.17
1	7 1/2" x 1 1/2"	"	20.40	.93.35	- 4.30	+ 6.75			4.27	6.71
1	7 1/2" x 3/4"	"	6.33	31.88	201.80	- 8.75	+ 7.55		17.66	15.24
4	15 5/8" x 3/4" x 3/8"	8.29	11.7	387.48	- 16.17	+ 3.50			82.66	13.56
4	"	14.-	"	655.20	- 16.50	+ 5.00			198.10	32.76
1	13 1/2" x 1/2"	8.29	16.58	137.65	- 16.17	+ 3.50			22.23	4.81
Total Main Material				1743.68						
Gusset 2										
2	7 1/2" x 1 1/2" x 3/8"	A=56.59	20.40	2337.94	- 8.66	+ 4.58			202.03	106.85
2	4 1/2" x 1 1/2" x 3/8"	A=22.86	25.50	1140.36	- 7.37	+ 5.66			84.04	63.54
2	15 5/8" x 3/4"	2.19	9.8	42.92	- 10.31	+ 7.30			4.42	3.13
Gusset 2										
2	4 1/2" x 1 1/2" x 3/8"	A=22.64	20.40	923.71	- 22.50	+ 3.13			192.13	28.91
1	13 1/2" x 1/2"	14.00	22.10	309.40	- 16.50	+ 5.00			57.05	15.47
1196 Riv. Mds. 3/8" per 100										
288	"	"	"	61.20	- 22.-	+ 3.5			13.46	2.14
100	"	"	"	21.25	- 16.25	+ 5.-			3.45	1.06
80	"	"	"	17.-	- 16.-	+ 3.66			2.72	.62
Total Details				6102.93						
Total Member				6846.61				804.24	325.21	
16-18-19 Main Material										
2	15 5/8" x 3/4"	32.87	9.8	626.22	- 8.-	- 6.58			51.70	42.52
2	15	33.10	"	648.76	- 8.-	- 7.92			51.90	51.38
2	18 1/2" x 3/8"	33.10	38.25	2532.41	- 8.-	- 7.25			202.57	183.58
Total Main Material				3827.12						
Cover 1										
1	7 1/2" x 1 1/2"	9.5	42.50	403.75	+ 0.29	- 6.48	117			26.16
Tip 2										
2	17 1/2" x 6" x 1/4"	6.02	28.92	348.32	+ 8.21	- 7.11	28.60			24.77
Gusset 62										
62	4 1/2" x 1 1/2" x 3/8"	A=15.25	20.40	622.20	+ 7.75	- 6.29	48.72			39.14
1 @ 1.82										
1	5 7/8" x 1 1/2" x 3/8"	A=33.69	"	1374.53	- 9.44	- 4.27			129.76	58.69
1	5 7/8" x 1 1/2" x 3/8"	A=23.3	"	950.64	- 22.00	- 5.58			209.14	53.05
2										
2	11 1/2" x 1 1/2"	3.08	17.25	78.54	+ 7.-	- 7.25	5.50			5.69
2	11 1/2"	5.61	30.60	343.33	- 8.75	- 7.25			30.04	24.89
2	14 x 1/2"	2.70	23.80	128.52	- 10.25	+ 1.0			13.17	12.9
2	18 6 x 3/4" x 1/2"	1.68	15.3	51.40	- 11.-	+ 1.83			5.65	9.4
1	18 25 x 1/2"	0.75	42.50	31.88	- 12.17	- 6.48			3.88	2.07
1	"	1.67	"	70.98	- 18.63	- 6.48			13.42	4.61
1	"	1.67	"	70.98	+ 5.50	- 8.02	3.90			5.71
1	3 x 1/2"	4.18	5.10	21.37	+ 8.50	- 8.02	1.81			1.71
1	25 x 1/2"	0.75	42.50	31.88	- 8.25	- 8.02			2.63	2.56
1	"	0.75	"	31.88	- 14.82	- 8.02			4.76	2.56
1	"	1.67	"	70.98	- 19.58	- 8.02			13.90	5.71
14	1/4" x 3" x 3/8"	2.81	5.31	208.88	- 1.67	- 8.02			3.49	16.75
4	"	2.81	"	68.68	- 17.08	- 8.02			10.19	4.79
6	"	2.81	"	89.52	- 15.17	- 6.48			13.58	5.80
Total Details				4989.33						
Total Member				8816.35			69.20	759.78	2.23	562.14
Notes for this member on next sheet.										

OFFICE OF BRIDGE ENGINEER
 OREGON STATE HIGHWAY COMMISSION
 SALEM, OREGON
FLOOR BEAMS. ①

Made by J.A.W. Date Aug. 4, 1920.
 Checked by O.G.A. Date Sept. 10, 1920.
 Backchecked J.A.W. Date Sept. 17, 1920.

Assignment No. 43
 Bridge No. 330
 Sheet No. 25 of

Calculations for Weights and C.G. Youngs Bay Bascule (North Leaf) Dwg L5

No. Pieces	Material	Length	Wt/Ft	Total Weight	X̄	Ȳ	+ X Moments	- X Moments	+ Y Moments	- Y Moments
Material for 1 Floor beam NFB1A from U1P to U1L (1 Per leaf - 2 Per bridge)										
Web	1	Web IP 25x1/2	22.67	42.50	963.48	+ 86.83	+ 4.90	836.59		47.21
Flange Top	1	L 5x5x7/16	22.88	14.3	327.18	+ 86.72	+ 5.87	277.66		18.79
"	"	L "	21.90	"	313.17	+ 86.84	+ 5.87	272.27		18.38
"	"	Bot L "	21.90	"	313.17	+ 86.84	+ 3.93	272.27		12.31
"	"	L "	22.88	"	327.18	+ 86.72	+ 3.93	277.66		12.66
Top Cov	1	IP 12x9/16	21.90	12.75	272.23	+ 86.83	+ 6.00	242.46		16.75
Bot Cov	1	IP 12x9/16	21.90	"	272.23	+ 86.83	+ 3.80	242.46		10.61
Total Main Material				2802.64						

Stiffeners	7	1/2 5x3x3/8	2.09	9.8	143.36	+ 86.98	+ 4.90	124.71		7.02
"	7	1/2 " "	2.09	"	143.36	+ 86.62	+ 4.90	124.26		7.02
"	7	1/2 3x7/16	1.29	4.6	40.85	+ 86.87	+ 4.90	34.92		1.97
"	7	" "	"	"	40.25	+ 86.79	+ 4.90	34.92		1.97
"	2	1/2 5x1/2	0.42	0.5	7.14	+ 86.62	+ 6.00	6.18		0.43
"	1	L 4x4x3/8	21.90	15.7	313.82	+ 87.31	+ 6.12	3002.0		21.04
"	1	L 4x4x1/2	21.90	12.8	206.32	+ 87.51	+ 6.20	182.30		12.92
1660	3/4 Riv. Hds.	per 100	14.25	236.55	+ 86.83	+ 4.90	205.40		11.59	
2	Bolts 3/4x1 3/4	" "	66	1.32	+ 86.60	+ 6.00	1.14		8	
Total Details				1164.36						
Total Member				3967.02			3435.45		20095	

Material for 1- Floor beam NFB2 from U2P to U2L (1 Per leaf - 2 Per Bridge)										
Web	1	IP 25x1/2	22.67	42.5	963.48	+ 71.17	+ 4.90	685.71		47.21
Top Flange	1	L 5x5x1/2	22.88	16.2	370.66	+ 71.29	+ 5.85	264.84		21.68
"	"	L "	21.90	"	354.78	+ 71.05	+ 5.85	252.07		20.75
Bot "	1	L "	21.90	"	354.78	+ 71.29	+ 3.95	252.92		14.01
"	"	L "	22.88	"	370.66	+ 71.05	+ 3.95	263.55		14.64
Total Main Material				2414.36						

Stiffs	7	1/2 5x3x3/8	2.09	9.8	143.36	+ 71.31	+ 4.90	102.23		7.02
"	7	1/2 " "	2.09	"	143.36	+ 71.03	+ 4.90	101.83		7.02
"	7	1/2 3x7/16	1.29	5.1	6.58	+ 71.13	+ 4.90	4.68		3.2
"	7	" "	1.29	"	6.58	+ 71.21	+ 4.90	4.69		3.2
"	2	1/2 5x4x1/2	0.85	16.2	30.78	+ 71.05	+ 4.90	21.87		1.51
572	3/4 Riv. Hds.	per 100	14.25	81.51	+ 71.17	+ 4.90	50.01		3.99	
4	Bolts 3/4x2	" "	67	2.68	+ 71.17	+ 4.90	1.91		13	
Total Details				414.85						
Total Member				2829.21			2013.51		13860	

OFFICE OF BRIDGE ENGINEER
OREGON STATE HIGHWAY COMMISSION
SALEM, OREGON

Made by J. A. W. Date Aug 5, 1920
Checked by G. G. A. Date Sept 11, 1920
Rechecked by J. A. W. Date Sept 17, 1920

Assignment No. 43
Bridge No. 330
Sheet No. 29 of 30 Sheets

STRINGERS (2)

Calculations for *Weights and C.G. Youngs Bay Bascule (North Leaf)*

Dwg L-7

No. Pieces	Material	Length	Wt/ft	Total Weight	X ² from trussion	Y ²	+X Moment	-X Moment	+Y Moment	-Y Moment	
Material for 20 Stringers "S" on North Leaf (This x 1 for Truss - x 2 for Bridge)											
Panel U2-U3	5	7s 15" @ 42"	15.46	42.0	3246.60	+ 63.33	+ 5.35	2056.07		17369	
	5	1s 6x6x 3/8	0.71	14.9	52.90	+ 71.03	+ 5.25	3757		278	
	5	1s "	0.71	"	52.90	+ 53.04	+ 5.25	2943		278	
	10	Bolts 3/4 x 2	per 100	69.00	6.90	+ 71.03	+ 5.25	4.90		36	
	10	"	"	"	6.90	+ 55.64	+ 5.25	3.84		36	
	100	Riv. Hds. 3/4	"	14.25	14.25	+ 71.03	+ 5.35	10.12		76	
	100	"	"	"	14.25	+ 55.64	+ 5.35	7.93		76	
	Total 5 Stringers - 1 Panel				3394.70			2149.86		18149	
	Panel U3-U4	5	7s 15" @ 42"	15.46	42.0	3246.60	+ 47.66	+ 5.35	1547.33		17369
		5	1s 6x6x 3/8	0.71	14.9	52.90	+ 53.36	+ 5.25	2929		278
5		1s "	0.71	"	52.90	+ 39.97	"	2114		278	
10		Bolts 3/4 x 2	per 100	69.0	6.90	+ 53.36	"	3.82		36	
10		"	"	"	6.90	+ 39.97	"	2.76		36	
100		3/4 Riv. Hds.	"	14.25	14.25	+ 53.36	+ 5.35	7.89		76	
100		"	"	"	14.25	+ 39.97	+ 5.35	5.70		76	
Total 5 Stringers - 1 Panel				3394.70			1617.93		18149		
Panel U4-U5		5	7s 15" @ 42"	15.46	42.0	3246.60	+ 32.00	+ 5.35	1038.91		17369
		5	1s 6x6x 3/8	0.71	14.9	52.90	+ 32.69	+ 5.25	2100		278
	5	1s "	0.71	"	52.90	+ 24.31	+ 5.25	12.86		278	
	10	Bolts 3/4 x 2	per 100	69.0	6.90	+ 32.69	+ 5.25	2.70		36	
	10	"	"	"	6.90	+ 24.31	+ 5.25	1.68		36	
	100	3/4 Riv. Hds.	"	14.25	14.25	+ 32.69	+ 5.35	5.66		76	
	100	"	"	"	14.25	+ 24.31	+ 5.35	3.46		76	
	Total 5 Stringers - 1 Panel				3394.70			10.8627		18149	
	Panel U5-U6	5	7s 15" @ 42"	17.68	42.0	3714.48	+ 15.22	+ 5.35	565.34		19872
		5	1s 6x6x 3/8	0.71	14.9	52.90	+ 24.03	+ 5.25	12.71		278
5		1s 8x8x 3/8	1.58	10.2	80.60	+ 6.42	+ 6.15	5.17		496	
10		1s 4x3x 3/8	1.05	8.5	89.25	+ 6.80	+ 6.10	6.16		544	
10		1s 6x6x 3/8	0.69	14.9	102.81	+ 5.85	+ 5.32	6.01		650	
10		Bolts 3/4 x 2	per 100	69.0	6.90	+ 24.03	+ 5.25	1.66		36	
50		Riv. Hds. 3/4	"	14.25	7.13	+ 24.17	+ 5.30	1.72		38	
120		"	"	"	17.10	+ 8.50	+ 4.73	1.45		81	
230		"	"	"	41.33	+ 6.42	+ 6.15	2.65		250	
110		"	"	"	15.68	+ 15.22	+ 5.98	2.39		94	
Total 5 Stringers - 1 Panel				4128.18			605.26		223.43		
TOTAL 20 STRINGERS				14312.28			5459.92		767.90		
Material in 1 Floor Plate F.P. (1 Per leaf - 2 Per Bridge)											
1	Check IP 1 1/2"	21.0	10.2	214.20	+ 5.25	+ 6.73	11.25		1442		
1	IP 11/4 x 3/4	21.0	28.69	602.49	+ 5.27	+ 6.69	31.75		40.31		
1	L 8 x 8 x 3/8	21.0	26.4	554.40	+ 5.57	+ 6.48	30.88		35.93		
9	L 7 x 3 1/2 x 1/2	0.54	17.0	82.62	+ 5.57	+ 6.45	4.60		5.33		
5	Bolts 3/4 x 1 1/4	per 100	66.0	3.30	+ 5.75	+ 6.50	1.9		21		
128	3/4 Riv. Heads	"	14.25	18.24	+ 5.25	+ 6.73	9.6		1.83		
Total Floor Plate				1475.25			79.63		97.45		

OFFICE OF BRIDGE ENGINEER
 OREGON STATE HIGHWAY COMMISSION
 SALEM, OREGON
FLOOR

Made by J.A.W. Date Aug. 9 1920
 Checked by O.G.A. Date Sept. 11 1920
 Backchecked by J.P.W. Date Sept. 17 1920

Assignment No. 43
 Bridge No. 330
 Sheet No. 30 of 30 Sheets
 Corrected 9/14/20

Calculations for Weights and C. G. Youngs Bay Bascule (North Leaf) Dwg. 116

No. Pieces	Material	Length	Wt./ft.	Total Weight	X ² from trunnion	Y ²	+X Moment	-X Moment	+Y Moment	-Y Moment
Laminated Sub Floor 2x6 (5 ³)										
	21x 82.08 Area = 1723.68	15.95		27492.70	+ 46.70	+ 6.20	12839.09			1704.55
2 layers	Felt Area = 1723.68	1.00		1723.68	+ 46.70	+ 6.25	808.96			111.18
2 Exp. Joints with 1 of Pitch	cut ft = 77	71.7		55.21	+ 46.70	+ 6.60	2578			364
Creas. Blocks 19.83x82.08 A = 1627.65										
3x6x3/2	= 472 Ft. 48.0			22656.00	+ 46.70	+ 6.60	10580.35			1495.30
40 Galv. 1 1/2 x 1/4 x 1/2	200	1.3		1040.00	+ 46.25	+ 6.50	481.00			6760
560 Wood Screws 2 1/2 x 3" period	6.3			35.28	+ 46.25	+ 6.50	16.32			2.29
13200 Casing Nails 8 1/4 p 1 1/4 ft				115.80	+ 46.25	+ 6.50	53.56			7.53
6 6" Carriage Bolts per 100	170			7.92	+ 46.25	+ 6.25	3.25			4.8
8 12" " " " "	132.0			15.36	+ 46.25	+ 6.25	7.10			9.6
280 8" " " " "	42.0			3.9260	+ 46.25	+ 6.25	1.8389			2485
Post Clips 24 1/2 6x8 x 1/2										
	1.00	23.0		552.00	+ 43.90	+ 7.60	242.33			4195
" 4 1/2 6x4 x 3/8	.83	12.3		40.83	+ 43.90	+ 7.60	17.92			3.10
" 16 1/2 6x4 x 3/8	.66	12.3		129.92	+ 43.90	+ 7.60	57.83			9.87
Rail Posts 36 3/4 Bolts 14" long per 100										
	212.0			78.12	+ 43.90	+ 7.60	34.29			5.94
" 40 " 10" " "	162.0			66.80	+ 43.90	+ 7.60	29.33			5.08
Curb 56 3/8 Bolts 18" long										
	182.8			102.57	+ 43.90	+ 7.75	44.94			6.91
Curb 164 1 1/2 x 3" Galv. Wood Screws										
	16.3			26.73	+ 43.90	+ 7.65	11.73			2.04
Curb 1.3" x 3" x 1/8"										
	162.0	4.9		793.80	+ 43.90	+ 7.65	348.48			6073
Curb 6x10-Wood										
	162.0	12.34		1999.00	+ 43.90	+ 6.95	877.56			13833
Posts 12 12x12										
	2.66	3.121		936.28	+ 43.90	+ 8.83	437.34			87.97
" 20 8x8	2.66	13.28		706.50	+ 43.90	+ 8.83	310.15			62.38
Rail 6x8										
	172.0	9.74		1675.28	+ 43.90	+ 8.83	735.45			147.93
Sand Coat 1/4 20x82' A = 1640' 3.0										
				4920.00	+ 46.70	+ 6.75	2207.64			332.10
Total Floor:				65626.22			30439.49			4323.27
REVISION ADOPTED SEPT. 14, 1920										
Lam. Fl. (2x8) 21x 82.08										
	Area = 1723.68	21.25		366.28						
2" Asphalt 20x82=1640'										
	273 Ft. 120"			32760						
				69388	+ 46.70	+ 6.20	32404.20			4302.06
2x6 Lam. floor, Felt, Pitch Creas. Blocks										
Sand Galv. 1/2 Wood Screws & Nails				58036			27098.70			3724.19
Net Increase				11,350			530,550			5,787

Office of BRIDGE ENGINEER
 OREGON STATE HIGHWAY COMMISSION
 SALEM, OREGON
MOVING MACHINERY

Made by J.A.W. Date Aug. 10, 1920 Assignment No. 43
 Checked by O.G.R. Date Sept. 11, 1920 Bridge No. 330
 Backchecked J.A.W. Date Sept. 18, 1920 Sheet No. 31 of 38

Calculations for Weights and G.G. Youngs Ray Bascule (North Leaf)

No. Pieces	Material	Length	Wt./ft.	Total Weight	X ⁺ from trunnion	Y ⁺	+X Moment	-X Moment	+Y Moment	-Y Moment
1 - Center Lock Mechanism (On North Leaf only)										
1	Shaft 2 1/2 dia	23.36	13.29	450.61	+ 82.83	+ 4.75	3732.4			2140
1	" 2 1/8 "	6.50	15.87	104.74	+ 81.50	+ 4.75	85.36			497
1	" 2 1/8 "	1.25	15.87	19.83	+ 81.50	+ 5.75	16.15			114
1	Std. Flg. Coupling			40.00	+ 82.83	+ 4.75	33.13			190
1	Bevel Gear			80.	+ 81.50	+ 4.75	65.20			380
1	" Pinion			30.	+ 81.50	+ 5.50	24.45			165
1	Spur Pinion			34.	+ 82.83	+ 4.75	28.16			162
1	" Gear			180.	+ 83.83	+ 4.75	150.89			855
1	Motor Pinion			46.	+ 85.00	+ 4.25	39.10			196
				0.						
2	Conn. Rod	@ 46.	92.	+ 84.33	+ 4.75	77.58				437
2	Cranks	@ 19.	38.	+ 82.83	+ 4.75	31.48				181
4	Step Bearings	@ 12.	48.	+ 82.83	+ 4.75	39.76				228
2	Lock Pins	@ 150.	300.	+ 87.33	+ 4.75	261.99				1425
2	" Slides	@ 117.	234.	+ 86.83	+ 4.75	203.18				1112
1	Box			10	+ 81.50	+ 4.75	8.15			48
1	Box			24	+ 81.50	+ 4.75	19.56			114
1	Box			8	+ 81.50	+ 4.75	6.52			38
1	Eccentric			31	+ 82.83	+ 4.75	25.68			147
1	Shift Lever			53	+ 82.15	+ 6.50	43.54			345
1	Capstan Case			48	+ 81.50	+ 6.50	39.17			312
7	Keys	@ 2.0	14	+ 82.83	+ 4.75	11.60				67
				1885.18						
1	3HP Motor			300	+ 85.00	+ 4.75	25500			1275
1	Canant Gear			300	+ 85.00	+ 4.25	25500			1235
1	Limit Switch			30	+ 85.00	+ 4.75	2550			128
28	3/8 Bolts 3 Tans	per 100	126.	35.28	+ 82.83	+ 4.75	29.72			168
4	3/4 " 7 "		128.4	5.17	+ 81.50	+ 4.75	4.71			25
106	3/8 Riv. Hds		2125	22.52	+ 86.83	+ 4.75	19.55			107
				692.97						
	Conduit Wires	86.	5#	430	+ 43.42	+ 4.0	186.71			1720
	(for Motors and Lamps)									
2	Navigation Lights	@ 50' ea.		100.00	+ 86.83	+ 3.25	86.83			325
				530.						
Total Center Lock Machinery				3108.15			244587			14176
2	Recks @ 40 - MB-UT			3334.-	- 8.90	- 1.38		296.73		4601
8	Bolts 7/8 x 2 1/2			84.8	- 8.90	- 1.38		75		12
58	" 3/8 x 1 1/2			194.88	- 8.90	- 1.38		173.4		269
156	" 3/8 x 2			67.80	- 8.90	- 1.38		6.03		94
116	Washers 3/8 Bolt per 100			13.92	- 8.90	- 1.38		124		19
156	" 3/8 " "			12.48	- 8.90	- 1.38		111		17
				6739.71			244587	32320	14176	5012

OFFICE OF BRIDGE ENGINEER
 OREGON STATE HIGHWAY COMMISSION
 BALTIM, OREGON

Made by... J.A.W. Date Aug. 28, 1920.
 Checked by P.A.F. Date Sept. 21, 1920.
 Batchchecked J.A.W. Date Oct. 5, 1920.

Assignment No. 43
 Bridge No. 330
 Sheet No. 39 of _____ sheets.

MOVING STEEL

Calculations for SUMMARY-WEIGHTS & C.G. YOUNGS BAY BASCULE - NORTH LEAF.

Sheet No	MEMBER	WEIGHT MAIN MATL.	PER 100	WEIGHT DETAILS	TOTAL WEIGHT	+ X MOM.	- X MOM.	+ Y MOM.	- Y MOM.	
1+2x2	U1-2-3 & L1-2-3	134.39	32.30	58.03	192.43	206	137.24	8.44	70	
3x2	U3-U4	35.09	96.30	14.98	50.08	24.40	0.00	3.38	0.00	
3x2	U4-U5	41.05	60.42	32.50	73.55	25.30	0.00	4.87	74	
7x2	U5-U6	45.82	16.41	32.34	78.16	14.26	0.00	5.18	74	
8x2	U6-U7	94.67	28.29	38.62	133.29	3.09	6.00	8.60	0.00	
11x2	U7-U9 Incl. MA-U9	34.87	36.74	1.02	36.89	22	13.69	18.24	6.50	
11x2	L6-B-9	76.34	24.56	99.78	176.32	70	1.78	15.19	5.46	
12x2	Vert U9-L9	19.27	24.69	4.76	24.03	22	25.06	13.87	0.00	
12x2	Vert M8-L8	9.68	38.14	1.53	11.21	32	0.00	0.86	31.02	
12x2	U7-L9 Diag	71.65	84.6	4.71	76.36	94	0.00	11.51	5.57	
13x2	U7-L9 Diag	70.90	24.22	20.31	91.21	32	0.00	1.21	5.57	
4x2	L3-L4	42.67	22.41	29.62	72.29	16	0.00	3.96	6.00	
5x2	L4-L5	21.19	22.41	32.09	53.28	36	0.00	2.52	1.68	
6x2	L5-L6	5.02	48.40	3.41	8.43	30	0.00	15.00	4.28	
8x2	Vert U4-L4	6.14	36.36	3.24	9.38	36	0.00	3.76	2.22	
8x2	Vert U5-L5	9.90	48.15	1.62	11.52	36	0.00	2.54	2.66	
10x2	Vert U6-L6	28.74	43.22	2.19	30.93	72	0.00	4.18	0.00	
6x2	L3-U4 Diag	12.08	40.26	10.80	22.88	20	0.00	7.82	0.00	
6x2	L4-U5 "	10.87	29.29	4.23	15.10	54	0.00	4.87	0.00	
9x2	L5-U6 "	11.34	28.29	4.16	15.50	18	0.00	2.70	3.32	
10x2	U6-T "	20.65	86.30	6.66	27.31	72	0.00	1.16	0.00	
2-TRUSSES		870.70	80.45	5.91	926.06	1462.40	86	0.00	0.00	
14x1	L1-B Sway Bracs	7.11	20.52	7.86	14.97	52	0.00	8.31	1.13	
14x1	L19 "	7.09	58.62	12.38	19.47	60	0.00	7.75	7.28	
15x1	L20 "	7.09	58.61	10.27	17.36	54	0.00	4.36	8.40	
16x1	L21 "	12.41	48.61	18.00	30.41	28	0.00	2.64	9.99	
17x1	L22 "	15.17	97.55	12.73	27.90	74	0.00	1.08	5.33	
21x1	L1-2 Lateral Diag	11.62	52.40	7.96	19.58	46	0.00	15.56	3.35	
22x1	L3-4-5 "	11.29	40.44	9.90	21.19	91	0.00	13.76	8.80	
22x1	L6-7 "	10.26	72.36	6.12	16.38	50	0.00	8.14	8.14	
23x1	L8-9 "	11.00	96.36	6.11	17.11	18	0.00	5.47	2.92	
23x1	L10-11-12 "	10.98	84.35	5.89	16.87	71	0.00	2.77	3.38	
24x1	L13-14 "	15.17	78.43	7.95	23.13	27	0.00	19.92	5.74	
18x1	CT-1 CHN Truss A	27.32	94.55	31.47	58.79	14	0.00	6.57	5.33	
19x1	CT-2 " " B	27.32	94.57	28.72	56.04	14	0.00	13.19	5.65	
20x1	CF-4 w/Cross Frame	11.31	60.37	6.61	17.92	30	0.00	3.13	8.84	
24x1	U5-U6 w/Water Bulb	16.83	60.16	3.21	20.04	97	0.00	3.51	5.52	
25x1	WF18 Floor Beams	28.02	84.29	11.64	39.66	23	0.00	3.43	5.45	
25x1	WF22 " "	24.14	36.15	4.44	28.58	21	0.00	2.03	5.11	
26x1	FB2 " "	25.53	89.15	4.42	30.95	59	0.00	16.13	2.25	
26x1	FB3 " "	23.24	11.17	4.82	28.06	21	0.00	11.21	7.11	
26x1	FB4 " "	23.24	11.17	4.82	28.06	21	0.00	6.80	7.03	
27x1	FB1 " "	27.16	85.51	28.07	55.23	94	0.00	4.62	7.00	
28x1	NS1 Rtl Stringer	12.97	80.53	7.80	20.77	60	0.00	10.87	5.00	
28x1	NS2 Rtl "	20.09	60.35	7.52	27.61	12	0.00	16.46	0.00	
28x1	NS3 " "	3.78	9.39	3.90	7.68	36	0.00	3.16	3.36	
28x1	NS4 Rtl "	6.91	40.16	12.86	19.77	26	0.00	6.84	2.74	
28x1	NS5 " "	2.76	63.14	4.42	7.18	27	0.00	2.73	8.00	
28x1	NS6 " "	5.45	60.9	5.48	10.93	18	0.00	4.81	6.33	
29x1	SDS "	1.34	54.28	6.58	7.92	28	0.00	5.53	2.90	
29x1	FF1 Floor Plate	2.14	20.84	12.61	14.75	25	0.00	7.93	9.74	
1-leaf		14.13	19.37	8.51	22.64	98	0.00	5.63	1.19	
30x1	Floor IS Galv.	10.40	-	-	-	-	0.00	-	-	
"	Curbs & Hand Rails	15.16	-	-	15.16	55	0.00	3.04	3.49	
"	Wood Floor	6.30	-	-	6.30	67	0.00	-	-	
31x1	Racks & Bolts	6.73	-	-	6.73	77	0.00	3.73	2.00	
37x1	L.L. RAILS	6.78	-	-	6.78	-	0.00	5.72	-	
31x1	Center of Machine	3.10	-	-	3.10	15	0.00	4.45	8.71	
GRAND TOTALS					3026.45	45.71	- 8.98	43.75	- 89.45	86.12

Form No. 10

OFFICE OF BRIDGE ENGINEER
OREGON STATE HIGHWAY COMMISSION
SALEM, OREGON
STEEL IN CWT.

Made by J.A.W. Date Nov. 22, 1920
Checked by P.A.F. Date Nov. 24, 1920
Backchecked by J.A.W. Date Nov. 27, 1920

Assignment No. 43
Bridge No. 330
Span No. 46 of Spans

Calculations for Weight and C.G. Youngs Bay Bascule. (North Leaf)

Structural Steel Embedded in Counterweight.

4 Ls 4x4 ^{3/8} x 14.0	=	56.0 lin.ft.	@	98 [#]	548.80
2 P 18x9 ^{1/2} x 14.0	=	28.0 "	@	38.25	1071.-
2 F ^{1/16} 18x9 x 1.0	=	2.0 "	@	30.60	61.20
2 P 25x1/2 x 0.75	=	4.82 "	@	42.5	204.85
2 P 25x1/2 x 1.66					
22 L.B. 2 1/2 x 9/8 x 2.8	=	61.6 "	@	5.31	327.09
2 P 12x1/2 x 8.25	=	16.5 "	@	20.4	336.60
2 Ls 6x3 3/4 x 7/16 x 9/4	=	18.28 "	@	13.5	246.78
1 P 13x 9/16 x 1.25	=	2.91 "	@	13.81	40.19
1 P 13x 9/16 x 1.66					
13 L.B. 2 1/2 x 9/16 x 1.15	=	14.95 "	@	2.66	39.77
2 Ls 6x3 3/4 x 1/2 x 1.68	=	3.36 "	@	15.3	51.41
2 P 14x1/2 x 1.0	=	2.0 "	@	23.8	47.60
2 P 24x 9/8 x 4.0	=	8.0 "	@	57.0	456.00
2 P 58 1/2 x 1/2 x 5.25	=	51.15 "	@	20.4	1043.05
2 P 12x1/2 x 3.25	=	32.16 lin.ft.	@	20.4	656.06
2 P 12x1/2 x 7.83					
2 P 12x1/2 x 5.0					
4 Ls 6x4 5/8 x 4.0	=	44.0 "	@	16.2	712.80
1 P 12x 3/8 x 11.0	=	11.0 "	@	15.3	168.30
2 P 27x 1/2 x 4.0	=	8.0 "	@	45.9	367.20
2 P 14x 5/8 x 14.25	=	42.75 "	@	29.75	1271.76
1 P 14x 9/8 x 14.25	=				
4 Ls 6x4x 3/8 x 14.25	=	57.0 "	@	20.0	1140.-
				1 Truss	8742.46
				1 Truss	8742.46
				2 Trusses	17484.92
				1 Counterweight Cross Frame	1793.30
				1 " Truss A.	5880.18
				1 " " B	5555.65
				Bottom Laterals L8-L9.	2004.97
				<u>Total Weight of Embedded Steel</u>	<u>32719.03[#]</u>

Volume of Embedded Steel = 32719 ÷ 490 = 67 Cu. ft. in Each Cwt.

<p>OFFICE OF BRIDGE ENGINEER OREGON STATE HIGHWAY COMMISSION SALEM, OREGON</p>	<p>Made by <u>J. A. W.</u> Date <u>Nov. 22,</u> 19<u>20.</u> Checked by <u>P. B. F.</u> Date <u>Nov. 24,</u> 19<u>20.</u> Backchecked <u>J. A. W.</u> Date <u>Nov. 27,</u> 19<u>20.</u></p>	<p>Assignment No. <u>43</u> Bridge No. <u>330</u> Sheet No. <u>47</u> of <u> </u> Sheets</p>			
<p>TOTAL VOLUME REQ'D.</p> <p>Calculations for <u>Counterweight Youngs Bay Bascule (North Leaf)</u></p>					
<p>Revised Calculations based on test weights of 147# per cu ft. for Unreinforced Cwt. Conc.</p>					
<p>Sept. 14, '20. Substituted 2x8 laminated floor and 2" Asphalt for orig 2x6 and Wood Block.</p>					
		+X Moment	-X Moment	+Y Moment	-Y Moment
5h.39. Total Weight	3026.45#	8984.375	8945.86	11016.32	360.479
Increase	113.50	5305.50		577.87	
Revised Totals	<u>3139.95#</u>	<u>9514.925</u>		<u>11596.19</u>	<u>-360.479</u>
Net Moments	<u>+X 26203.39</u>			<u>+Y 7991.40</u>	

$8629.339 \div 3139.95 = 27.454 = \text{Horizontal dist. of C.G. from Trunnion}$
 $799.140 \div 3139.95 = 2.545 = \text{Vertical " " " " "}$

C. G. Moved forward .09' to 27.36' and Upward .135' to 2.41'

$3139.95 \times 27.36 = 8,590,903 \#'$
 (Corrected Horiz. Moment)

$3139.95 \times 2.41 = 756,727 \#'$
 (Corrected Vert. Moment)

To find dist below Trunnion to place C.G. of Cwt 2.41 : 27.36 :: X : 17.59 X = 1.549 1.549 - .135 = 1.41'

$8,590,903 \div 17.59 = 488,396 \# = \text{Wt. of Cwt. Req'd.}$

Wt. of Concrete : - from test blocks = + 147# per cu. ft.
 1" Sq bars 12" o.c. all three ways = 3# per cu. ft. = + 10.26#
 Steel replaces 36 Cu. in. of Concrete @ 147# = - 3.07#
 Net wt. of Finished Reinforced Cwt = 154.19# per cu. ft.

Volume of Reinforced Cwt. = $488,396 \div 154.19 = 3167 \text{ Cu. ft. or } 117.3 \text{ Cu. Yds.}$

MIN. NO. 10

OFFICE OF BRIDGE ENGINEER
OREGON STATE HIGHWAY COMMISSION
SALEM, OREGON

Made by J.A.W. Date Nov. 22, 1920.
Checked by P.A.E. Date Nov. 24, 1920.
Backchecked J.A.W. Date Nov. 27, 1920.

Assignment No. 43
Bridge No. 330
Sheet No. 48 of Sheets

GOVERNING DIMENSIONS

Calculations for Counterweight Youngs Bay Bascule (North Leaf)

100% of Reinforced Concrete Cwt. Reqd = 3167 Cu.ft.
2 1/2% allowance for seasonal variation = 79
97 1/2% = Net Permanent Cwt reqd = 3088 Cu.ft.

11.75' = limit of height for main block of finished cwt.

End area of Equivalent Solid mass = $3167 \div 25.33 = 125.0^{\text{cu}} \text{ (approx.)}$

Correction to apply to length to allow for 67 cu.ft. of embedded Struc. Steel = $67 \div 125.0 = 0.53'$

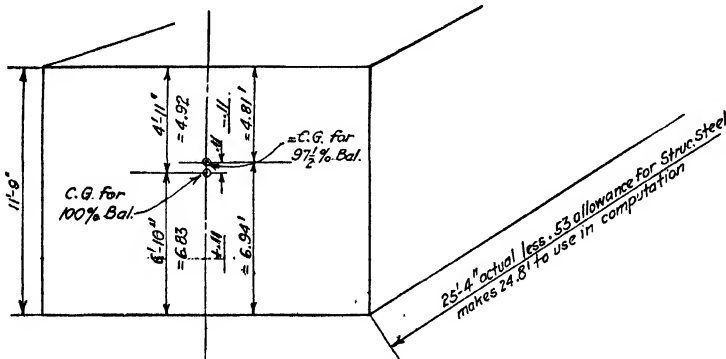
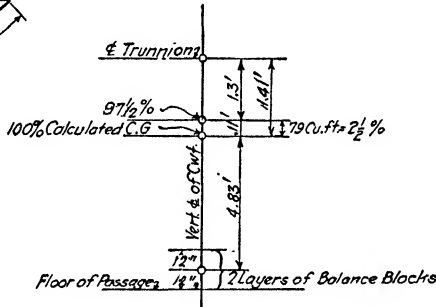
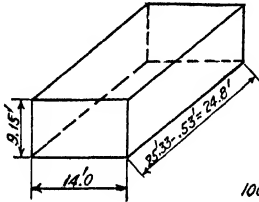

DESIGN OF OPERATING MACHINERY

Doubtless the most logical method of presentation is by means of an illustrative problem, for which reason the complete machinery design for the double leaf, trunnion, bascule highway bridge shown in Fig. 99 will be considered at this time.

It is not possible in the limited space available to treat the subject of machine design with any degree of thoroughness. The subject matter hereinafter presented will therefore be restricted to apply to the matter of calculations for design and proportioning of parts, treating the matter of machine details only incidentally, and with the utmost brevity.

The two features which stand out as peculiar to the problem of design and selection of bascule machinery are: (1) The highly intermittent character of the duty, and (2) the uncertainty as to the loadings. It will be observed that a very large percentage of the loading imposed upon the machinery and power equipment is due to wind action, and that the actual maximum load of this character which may reasonably be expected is largely a matter of conjecture. For the foregoing reason bascule machine design is approached with an attitude slightly different from that for other mechanical equipment. Set and standard formulas may be subject to certain modification and stress calculation judgment tempered, to a certain extent, by experience and sense of proportion.

In the problem which follows it has been thought best to interpolate such discussion as would serve to illustrate the foregoing thought and to confine the subject matter to the particular problem in hand avoiding any derivation of formulas or general discussion of the question of machine design. The work is intended to outline the general method of procedure, to illustrate the character of the problem involved, and to stimulate further investigation. A complete treatment of any of the individual problems involved may be found in any of the standard text or handbooks on machine design.

35. General Data for Problem in Hand.

Distance center to center trunnions.....	175 ft. 8 in.
Distance center to center trusses.....	23 ft.
Rack radius.....	9 ft.
Angle of opening.....	70 deg.
Dead load (moving) (one truss only)	
River arm.....	104,748 lb.
Rear arm (concrete).....	228,044
Rear arm (steel).....	24,858
	<hr/>
Total weight.....	357,650 lb.

- Distance center to center river arm to trunnion..... 41.40 ft.
- Distance center of gravity rear arm (steel) to trunnion.... 12.56 ft.
- Distance center of gravity rear arm (concrete) to trunnion. 17.50 ft.
- Area of floor (one truss) 83 × 12 ft. 6 in. = 1,037 sq. ft.
- Distance center of gravity of floor area from trunnion..... 46.0 ft. (approx.)

The above data, in practice, are computed from the structural calculations, by the structural designing squad and turned over to the machine designer in this form. The data are not exact, but closely approximate. Such items as the weight of the center lock machinery and the position of its gravity center must be assumed outright as calculations for the design of this portion of the work are yet to be made. The final results will doubtless slightly modify the total weight of the river arm and the position of its gravity center. The difference, however, is rarely enough to necessitate a revision of the machinery and power calculations.

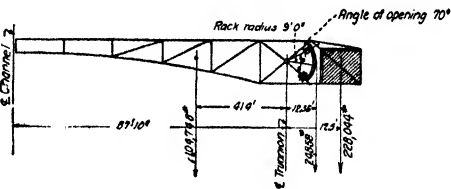

FIG. 99.—General dimensions and weights.

36. Wind Pressure Assumptions.—The following relationship, given by the formula $P = 0.0032V^2$, may prove of value in formulating an assumption as to probable wind loadings:

WIND VELOCITY (MILES PER HR.)	WIND PRESSURE (LB. PER SQ. FT.)
V	P
40	5
55	10
69	15
79	20

It seems quite improbable that the machinery need ever be called upon to operate against a wind in excess of 50 miles per hour velocity. However, it has been common practice to design machinery of this character against wind pressures between 10 and 15 lb. acting normal to the river arm. Viewed in another light a 15-lb. wind assumption, while erring slightly on the side of conservatism, furnishes a concisely stated requirement which will result in massive and well-designed machinery, stable against the countless impact and racking strains which militate against the life of mechanical equipment of this type and which are so hard to determine exactly. The machinery in this case will be calculated for the extreme 15-lb. wind pressure viewed in the light of a blanket specification as above set forth. Slight modifications in the design of various parts because of the severity of this clause will be discussed as the design is developed.

37. Friction on Trunnions.—The laws governing friction on well lubricated surfaces are considerably different from those for surfaces

which are dry, or which are insufficiently lubricated. If the surfaces are flooded with lubricant, the actual frictional resistance seems to be nearly independent of the pressure per square inch. At low pressures, the friction is a direct function of the speed, but for high pressures the friction is very great even for low velocities, approaching a minimum at a linear velocity of about 2 ft. per sec. and thereafter increasing approximately as the square root of the speed. For first class lubrication, the temperature has a marked bearing on the frictional resistance due to the fact that temperature changes cause a change in the viscosity of the lubricant and also because the diameter of the bearing changes more rapidly with a change in temperature than that of the shaft.

The coefficient of friction to be assumed in work of this character is dependent upon so many variable factors that it is impossible to formulate assumptions which are dependable except in a very general way. It is general practice in bascule bridge design to assume the following coefficients for trunnion and roller friction: (1) Forged steel trunnions in phosphor bronze bushings, 15 per cent; (2) rolling lift bascule spans, 8 per cent. Experiments seem to indicate that the coefficient of friction at starting will be several times as great as that for the friction of motion. The method of lubrication, and the quality of the lubricant has also a considerable bearing on the frictional resistance developed. All considered, the above values may be said to represent conservative practice, and to err, if at all, on the side of safety.

38. Maximum Starting Force at the Rack Circle.—The tangential force at the rack circle applied through the operating pinion must be sufficient to overcome the following resistances: (1) Inertia of the moving mass; (2) wind resistance; and (3) frictional resistances.

38a. Inertia of the Moving Mass.—The force required to produce an acceleration a is given by the formula

$$F = Ma$$

where M = the equivalent mass at the rack circle, and a = the acceleration in feet per second. If a given weight W has its gravity center a distance c from the center of rotation, the equivalent mass (not weight) reduced to a rack of radius r may be had from the formula

$$M = \frac{Wc^2}{32.2r^2} \quad \text{or} \quad Mr^2 = \frac{Wc^2}{32.2}$$

Applying these formulas with the data given:

$$Mr^2 \text{ (For the river arm)} = (104,748)(41.40)^2 \div 32.2 = 5,576,700$$

$$Mr^2 \text{ (For the rear arm)(steel)} = (24,858)(12.56)^2 \div 32.2 = 122,000$$

$$Mr^2 \text{ (For rear arm)(concrete)} = (228,044)(17.50)^2 \div 32.2 = 2,169,000$$

$$Mr^2 \text{ (Total)} \quad \quad \quad 7,867,700$$

$$M = \text{(Round numbers)} \quad \quad \quad 97,100$$

ft.-lb.

For 70-deg. angular rotation the length of travel on the rack is

$$\frac{(2\pi)(9)(70 \text{ deg.})}{360 \text{ deg.}} = 11 \text{ ft. (approx.)}$$

The usual time allowed for the complete opening of a span of this size is about 1 min. (the allowed opening time of course depends upon the importance of a speedy handling of traffic, certainly not more than 1½ min., and preferably not more than 1 min. should be allowed for completely raising the span). Fixing the total time of opening at 1 min., the first 15 sec. may be assumed as constituting the period of acceleration, the last 15 sec. the period of retardation, leaving the intermediate period of 30 sec. for uniform motion. The uniform speed therefore becomes

$$\frac{11}{(15\frac{1}{2} + 30 + 15\frac{1}{2})} = 11\frac{1}{45} = 0.244 \text{ ft. per sec.}$$

The acceleration is, therefore,

$$\frac{0.244}{15} = 0.01626 \text{ ft. per sec.}^2$$

and

$$F = Ma = (97,100)(0.01626) = 1,580 \text{ lb. (for one rack)}$$

38b. Wind Resistance.—The area of floor (for one truss) exposed to wind action is 1,037 sq. ft. (see general data) and its gravity center lies 46 ft. from the center of the main trunnion. The tangential force at the rack circle due to a 15-lb. wind is, therefore

$$\frac{(1,037)(15)(46)}{9} = 79,500 \text{ lb.}$$

38c. Frictional Resistance.

Load on trunnion (dead load).....	357,650 lb.
Wind load pinion reaction (see Fig. 100).....	79,500
	<hr/>
Total.....	437,150 lb.

This frictional force is applied at the periphery of the trunnion (see Fig. 100), and before we can proceed further the dimensions of this trunnion must be roughly determined. The unit bearing values usually assumed for slow moving heavy duty journals of this character (steel on phosphor bronze) vary from 1,500 to 1,750 lb. per sq. in. Assuming a 12-in. length for each journal and an 11-in. trunnion, the unit pressure becomes

$$\frac{437,150}{(2)(12)(11)} = 1,650 \text{ lb.}$$

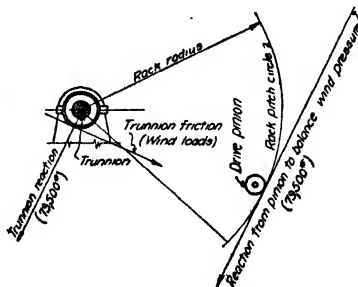

FIG. 100.

(The above is approximate only since the dead load and the pinion reaction do not act in the same direction, see Art. 51.) This value is under the maximum specification. We may therefore use a trunnion of 11-in. diameter as a basis for calculation.

The frictional force, reduced to the periphery of the rack circle, is, therefore:

$$\frac{(437,150)(5\frac{1}{2})}{108} (0.15) = 3,300 \text{ lb.}$$

38d. Total Tangential Force at Rack Circle.—Summing up, the total tangential force at the rack circle is:

Inertial.....	1,580 lb.
Wind.....	79,500
Frictional.....	3,300

Total.....	84,380 lb. (say 84,000)

It will be observed that the wind loading constitutes nearly 95 per cent of the total. The entire design of the operating machinery is, therefore, dependent upon the assumptions made as to wind pressures. In view of the fact that the 15-lb. wind assumption is undoubtedly rather severe it may be well to tabulate values for the tangential force for other wind pressure assumptions, as follows:

Frictional and inertial resistance alone....	4,875 lb.
5-lb. wind	
Frictional and inertial resistances.....	4,875 lb.
Wind resistance.....	26,500 lb.

Total.....	31,375 lb. (say 31,000)
10-lb. wind	
Frictional and inertial resistances.....	4,875 lb.
Wind resistance.....	53,000

Total.....	57,845 lb. (say 57,500)

39. Design of Rack and Main Drive Pinion.—The rack in this case is bolted between wide gusset plates on the truss and its width is determined by the design of the truss members. Racks of this character are made of cast steel usually cast in sections, the adjoining surfaces being carefully machined. The rack sections are bolted to the structural steel, by means of turned bolts. Figure 101 is a sketch showing the details of the rack designed to fit this particular truss. Figure 102 is a construction view of the same rack.

Before taking up the design of this portion of the work it may be well to take up very briefly the matter of gear design in general. The terms used in designating the various parts of a set of spur gearing are given in Fig. 103.

If two wheels are geared to mesh: (1) The circular pitches are equal; (2) the pitch circles are mutually tangent; (3) the two pitch diameters

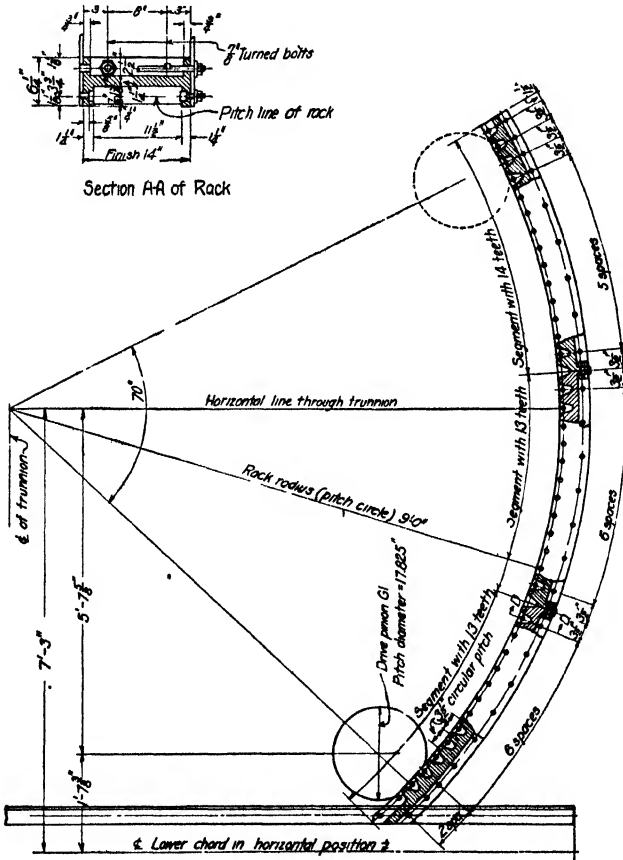

FIG. 101.—Details of operating rack.

are proportional to the number of teeth; (4) the linear velocities of the two wheels at the pitch circle are equal; and (5) the angular velocities are inversely proportional to the pitch diameters.

There are in general two standard types of gear teeth in common use, the cycloidal and the involute, the latter type being the most commonly used and the type selected throughout this design. The involute tooth is designated by the angle ϕ which the common tangent at the contact point makes with a line joining the centers of the two wheels. The stand-

ard involute tooth is 15 deg., or sometimes $14\frac{1}{2}$ deg. (Brown and Sharpe standard), but 20-deg. involute teeth are often used for heavy duty gearing on account of the increased root thickness R .

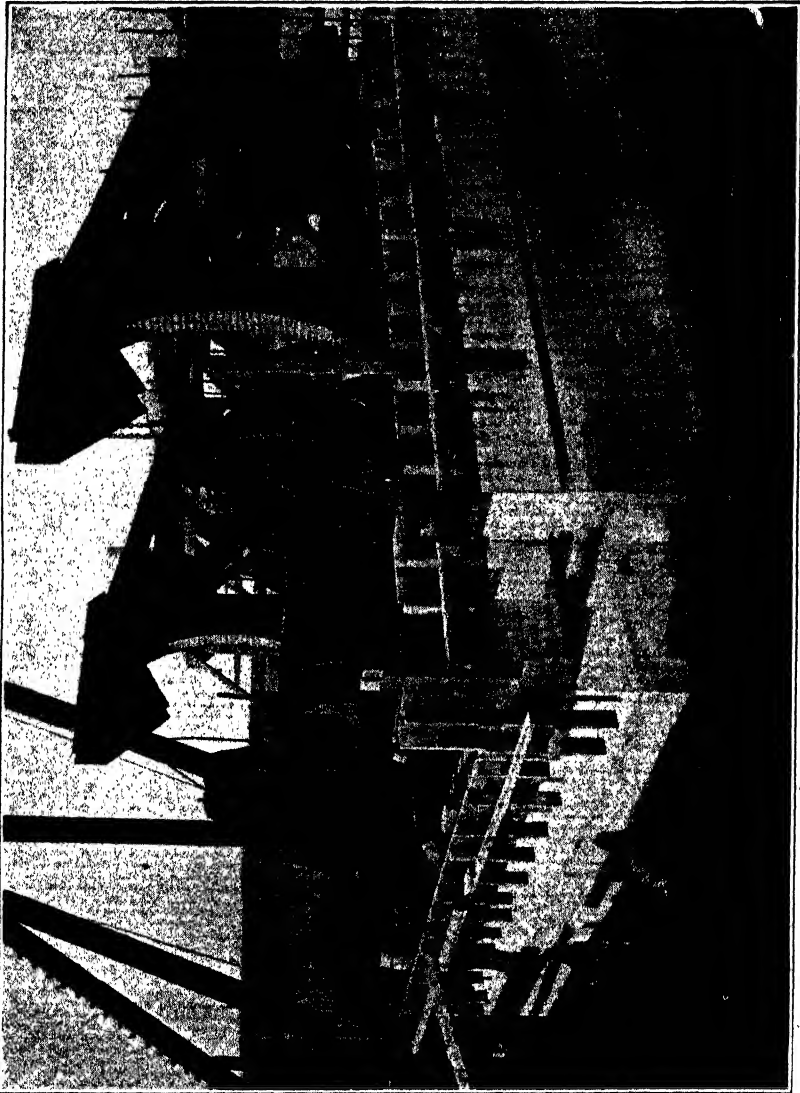

FIG. 102.—Youngs Bay bascule. View showing rack and trunion bearings.

Many formulas have been devised for determining the strength of gear teeth, the most generally accepted being that of Wilfred Lewis as follows:

$$s = \frac{F}{\psi f y}$$

where

- s = the unit fiber stress in the material.
- F = the total tooth pressure.
- p = the circular pitch.
- f = the width of the tooth face.
- y = a constant depending on the number and shape of the gear teeth.

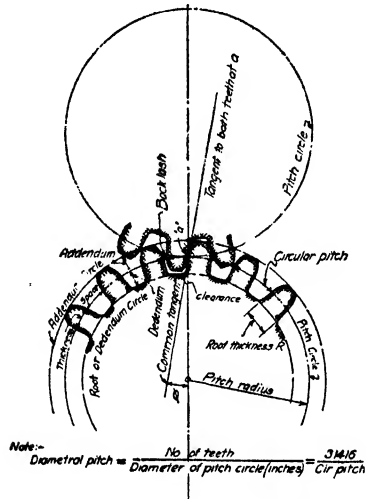

FIG. 103.—Principal dimensions and terms used for designating gear teeth.

Values of the constant y for the commonly used gear sizes are given in the following table:

Number of teeth	Values of y		Number of teeth	Values of y	
	20 deg. involute	15 deg. involute and cycloidal		20 deg. involute	15 deg. involute and cycloidal
12	0.078	0.067	27	0.111	0.100
13	0.083	0.070	30	0.114	0.102
14	0.088	0.072	34	0.118	0.104
15	0.092	0.075	38	0.122	0.107
16	0.094	0.077	43	0.126	0.110
17	0.096	0.080	50	0.130	0.112
18	0.098	0.083	60	0.134	0.114
19	0.100	0.087	75	0.138	0.116
20	0.102	0.090	100	0.142	0.118
21	0.104	0.092	150	0.146	0.120
23	0.106	0.094	300	0.150	0.122
25	0.108	0.097	Rack	0.154	0.124

The unit allowable working stresses employed in the design of gearing by the Lewis formula have been the subject of much discussion. In general the value selected for the different tooth speeds will vary between the limits shown below depending upon the material and workmanship. Forged steel gears and pinions may well be stressed to a higher value than cut cast gears. Rough molded gears should be stressed to a much less value than gears with machined teeth, etc. For working stresses induced by the maximum 15-lb. wind loading, it is quite general practice, in work of this character, to even increase the maximum stress values given below by a small percentage:

Tooth speed (ft. per min.)	Unit working stress (lb. per sq. in.) (For use in the Lewis formula)	
	Steel gears	Cast iron gears
100	15,000 to 20,000	6,000 to 8,000
200	12,000 to 15,000	4,500 to 6,000
300	9,000 to 12,000	4,000 to 4,800
600	7,500 to 10,000	3,000 to 4,000
900	6,000 to 8,000	2,500 to 3,000
1,200	4,500 to 6,000	2,000 to 2,400
1,800	3,750 to 5,000	1,500 to 2,000

With these data we may proceed with the design of the rack and main drive pinion $G1$ (see Figs. 101 and 104). Since the pinion is to be designed for heavy duty let us adopt a 20-deg. involute tooth. Assuming a circular pitch of $3\frac{1}{2}$ in., a tooth face of 11 in. (which is as wide as is possible with the rack used) and a pinion of 16 teeth, we find

$$s = \frac{84,000}{(3\frac{1}{2})(11)(0.094)} = 23,200 \text{ lb. per sq. in.}$$

For holding (not operating) against a 15-lb. wind the inertial resistance would be eliminated. Moreover the frictional resistance would be *deducted* rather than *added* to the wind resistance and the tooth pressure would become

$$s = \frac{(79,500 - 3,300)}{(3\frac{1}{2})(11)(0.094)} = 21,200 \text{ lb.}$$

For operating against a 10-lb. wind

$$s = \frac{57,500}{(3\frac{1}{2})(11)(0.094)} = 15,900 \text{ lb.}$$

With the maximum wind condition the pinion is only 16 per cent overstressed (assuming a 20,000-lb. working stress for forged steel) which is

within the limits of overstress generally allowed for the 15-lb. wind condition.

The number of teeth in a full rack circle of radius 9 ft. would be nearly 200 (see Fig. 101). The tooth stress in the rack therefore becomes

$$s = \frac{84,000}{(3\frac{1}{2})(11)(0.147)} = 14,700 \text{ lb.}$$

which value is safe even for molded teeth. In this case the rack teeth are required to be hand finished which doubtless permits of a larger unit stress being used.

It is quite customary in work of this kind to use molded teeth for heavy duty racks without machining the teeth, in which case the use of a lower unit stress is doubtless the part of wisdom.

40. Machinery Layout.—Having the main drive pinion designed it becomes necessary before further designing can be done to sketch in at least a tentative layout of gears and shafting. The nature of this layout will of course depend upon the structural dimensions of the bridge, the clearances, etc. While making these layouts, it becomes necessary to make "rough in" or preliminary calculations for clearances, etc. These preliminary calculations do not differ in principle from the final calculations and are not given here. Figure 104 shows the general layout made after those rough in calculations were finished.

The motors are direct connected to shaft *S4* and drive through *S4* from pinion *G9* to *G8*. Gears *G8* and *G7* are fastened together and idle or rotate on shaft *S2*. Pinion *G7*, however, meshes with gear *G6* which gear, together with pinion *G5*, is keyed to shaft *S3*. The motion is thus transmitted to *G5* and from *G5* to *G4* which is keyed to shaft *S2*. Shaft *S2* transmits the power to pinion *G3* and thence through *G2* to shaft *S1*, thence to pinion *G1* which meshes with the rack. When the bridge is to operate by hand, gears *G7* and *G8* are moved along the shaft *S2* so that *G8* becomes out of mesh with *G9* and the bevel gears *G10* and *G11* are meshed. This operation is performed by removing a set collar and sliding the gears back or forth as may be desired, replacing the set collar to clamp them in the desired position.

The problem of determining the best arrangement for the machinery is, in each case, an individual one; the following general principles however, should guide the designer in every case:

(1) As between several different arrangements the most efficient and economical layout is generally

- (a) The one that is most compact and simple.
- (b) The one that permits easiest access to all portions of the machinery.
- (c) The one that contains the smallest number of moving parts.

(2) Avoid the use of bevel, miter or angle gearing wherever possible as the efficiency is lower (85 per cent against 90 to 95 per cent). These

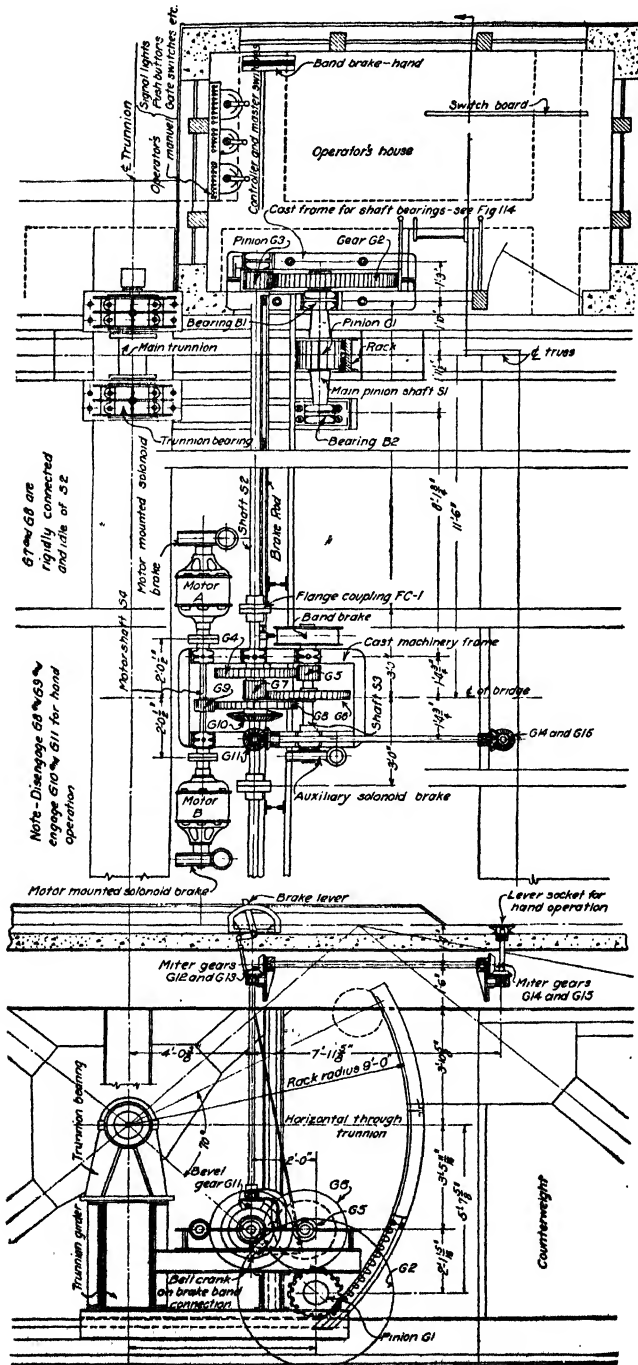

Fig. 104.

gears are moreover hard to maintain in exact alignment and are apt to rattle.

(3) Avoid the use of worm gearing for transmission of power on account of the excessive friction loss. (The efficiency of a worm drive is between 50 and 65 per cent, as against 90 to 95 per cent for spur gearing.)

(4) Wherever possible, place machinery on heavy unit castings, as shown in Fig. 115, rigidly anchored to the masonry, avoiding the use of structural members as a support for the machinery bases.

(5) Arrange machinery details so that exact alignment during construction is easily possible (eliminating complex instrument work).

(6) Avoid long shafting if possible, and, where unavoidable, transmit power through it at comparatively high speed. In other words, if long shafting must be used, make the high speed shafts rather than the low speed shafts the long ones. There is a very great amount of vibration in machinery of this kind. Long drive shafting has been observed having a movement under load so great that intermediate gears are nearly thrown out of mesh. Shafts such as *S2* in Fig. 104 should be steadied by intermediate boxings at every point possible, particularly if such shafts are to carry gears at intermediate points.

(7) Avoid short vertical shafts and the consequent necessity for foot step bearings as these require hardened steel and are much harder to maintain than horizontal bearings.

(8) Arrange machinery in general so that all parts, especially those subjected to wear, may be readily removed for repairs or replacement without disturbing the remainder of the machinery.

41. Design of Gearing.—Before definitely deciding upon the gearing dimensions it is necessary to ascertain something of the power required to operate the span and at what speed the power plant is to operate, for without these data we are unable to determine what gear reductions are necessary.

The maximum tangential force applied at the rack circle by the main drive pinion is 84,000 lb. (15-lb. wind load). The pitch radius of the main drive pinion is $(3\frac{1}{2})(16) \div 2\pi = 8.912$ in. The maximum torque on the drive pinion is, therefore,

$$(84,000)(8.912) = 750,000 \text{ in.-lb. or } 62,500 \text{ ft.-lb.}$$

For other wind intensities the torque is as follows:

$$10\text{-lb. wind } (57,500)(8.912) = 510,000 \text{ in.-lb.} = 42,500 \text{ ft.-lb.}$$

$$5\text{-lb. wind } (31,000)(8.912) = 276,000 \text{ in.-lb.} = 23,000 \text{ ft.-lb.}$$

$$0 \text{ wind } (4,875)(8.912) = 43,600 \text{ in.-lb.} = 3,600 \text{ ft.-lb.}$$

The maximum linear velocity of the rack (and therefore that of the pinion) has been calculated to be 0.244 ft. per sec. or 14.64 ft. per min.

The circumference of the drive pinion is $\frac{2\pi(8.912)}{12} = 4.66$ ft. at the pitch

circle. The rpm of the pinion is therefore $\frac{14.64}{4.66} = 3.15$ rev. per min. The power required to operate each pinion is given by the formula

$$\text{h.p.} = \frac{2\pi(\text{torque})(\text{RPM})}{33,000} = \frac{2\pi(62,500)(3.15)}{33,000} = 37.4 \text{ h.p. per truss.}$$

The above represents the power needed *at the drive pinion* and must be increased by a margin sufficient to cover the friction loss between this drive pinion and the motor shaft.

For spur gearing the efficiencies at different speeds may be assumed as follows:

Speed of gear (ft. per min.)	Efficiency (per cent)			
	Gear only		Gear and journal	
	Machine cut teeth	Molded teeth	Machine cut teeth	Molded teeth
3	90	85	88	83
10	93	88	90	85
40	96	90	93	88
100	97	..	94	
200	98	..	95	

There will be about four sets of spur gearing and journals between the main drive pinion and the motor shaft. Assuming an average efficiency of 95 per cent for each set, the over-all efficiency becomes $(0.95)^4 = 0.81+$ and the amount of power needed to overcome this friction loss will be 100 per cent $\div 0.81 = 124$ per cent, or roughly 25 per cent excess power. The excess torque needed is also about 25 per cent. We may now tabulate our requirements for torque and power for the various wind loadings:

Wind load (lb.)	H.p. required		Torque required (ft.-lb.) (Reduced to pinion speed)	
	One truss	One leaf	One truss	One leaf
0	2.7	5.4	4,500	9,000
5	17.2	34.4	28,700	57,400
10	31.8	63.6	53,000	106,000
15	46.7	93.4	78,000	156,000
For holding (not operating) against a 15-lb. wind the values become 76,500 84,000 of the last values above....	42.5	85.0	71,000	144,000

Electric power should be selected wherever the same is available as the operation is much more satisfactory than with any other type of power. Electric power will be used in this case and without going into the question of power plant selection suffice it to say that two motors for each leaf seem to be the logical power equipment.

For successful operation these motors should meet the following requirements:

(a) The two motors combined should operate the leaf in the required opening time against a 10-lb. wind.

(b) The *maximum* torque of the combined motors should be at least 50 per cent in excess of the torque required to *hold* (not operate) against a 15-lb. wind.

(c) Either motor *alone* should develop a *maximum* torque 10 per cent in excess of the torque required to operate the leaf against a 10-lb. wind.

From the manufacturers of electrical equipment, data concerning the speed and torque values for the various standard motors may always be secured, and from such data a tentative selection may be made.

The following table is typical of data of this character, the motors being 440-volt A.C. slip ring, induction motors which will be the type selected for this problem.

TABLE OF SPEEDS AND TORQUES
(440-volt A.C. Induction Motors)

H.p.	Speed rev. per min.		Torque (ft.-lb.)	
	Synchronous	Full load	Full load	Maximum
15	1,200	1,125	70	165
15	900	830	95	250
18	720	680	139	390
22	1,200	1,135	102	240
22	900	850	136	400
22	720	680	170	500
30	1,200	1,145	137	400
30	900	580	188	525
35	1,200	1,140	161	410
37	1,200	1,155	168	600
37	600	570	340	870
52	900	860	318	1,000
52	600	570	480	1,150

We will tentatively select two 35-h.p. motors as per the above table and determine if these meet all requirements.

The speed of the motor at full load is 1,140 rev. per min., the gear reduction between the main pinion and said motor shaft must therefore be $1,140 \div 3.15 = 362$.

These are only slightly in excess of the torques computed on the basis of a gear reduction of 362 and are still within the limits of motor performance as given under the headings *a*, *b* and *c* above.

We may now proceed with the design of the gears. Gear *G2* being considerably larger than the main drive pinion and transmitting the same torque will be required to transmit a smaller tangential force. We are therefore safe in assuming a much smaller tooth thickness. Let us assume a circular pitch of $2\frac{1}{8}$ in. (using 20-deg. involute teeth as before) and a face width of $4\frac{1}{2}$ in.

- p* (circular pitch)..... $2\frac{1}{8}$ in.
- f* (face width)..... $4\frac{1}{2}$ in.
- y* (from table)..... 1.41

Pitch diameter (for 90-tooth gear) = $(90)(2\frac{1}{8}) \div \pi = 60.87$ in.

F (tangential pressure) = $(84,000) \left(\frac{17.82}{60.87} \right) = 24,600$ lb.

The tooth speed at the pitch circle is $(3.15)(\pi) \left(\frac{60.87}{12} \right) = 50$ ft. per min.

We may, therefore, assume the efficiency of the pair of gears (including the journal friction) as 93 per cent, whence

F (including friction loss) = $\frac{24,600}{0.93} = 26,500$ lb.

s = $\frac{26,500}{(4\frac{1}{2})(2\frac{1}{8})(0.141)} = 19,600$ lb. per sq. in.

which is safe for a tooth speed less than 100 ft. per min. (see table, Art. 39).

For pinion *G3*, assuming a face width of $6\frac{1}{2}$ in.,

s = $\frac{26,500}{(6\frac{1}{2})(2\frac{1}{8})(0.092)} = 21,000$ lb. per sq. in.

For a 10-lb. wind the tooth stress is $\left(\frac{57,500}{84,000} \right)$ of the above or 14,500 lb. per sq. in.

The gears in general are made of cast steel while the pinions are made of forged steel, the teeth to be cut from the solid. It is therefore entirely permissible to stress a pinion slightly higher than its meshing (cast steel) gear. The above dimensions are therefore entirely satisfactory.

In like manner the design for the entire gear train is worked out. The results are tabulated below.

It will be noted that the rest of the gears are designated by diametral, rather than circular pitch. The pitch diameter is given at once by the expression

$$\text{pitch diameter} = \frac{\text{number of teeth}}{\text{diametral pitch}}$$

and the circular pitch *cp* is found from the formula

$$\text{circular pitch} = \pi \div (\text{diametral pitch})$$

In general, circular pitch is used for cast gearing and for large milled teeth while diametral pitch is used for smaller cut gears and pinions. Unless otherwise noted, all gears are to be of cast steel and all pinions of forged steel.

Most gears for work of this character are of cast steel with forged steel pinions. For minor parts the use of cast iron is sometimes permitted.

Lately the tendency is toward the use of heat treated and hardened gears and pinions; nickel, chrome nickel, chrome vanadium and high carbon steels being used. The advantages accruing from the use of heat treated metal are: Greatly increased strength, low rate of wear and consequent long life, infrequency of renewals and the possibility of using higher working stresses, thus producing a more compact design.

Hardened gears are sometimes ground and polished (using garnet or some other abrasive), thus producing an exceptionally quiet and smooth running train of gears.

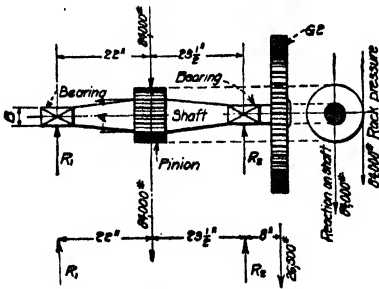

FIG. 105.

42. Design of Shafting.—Figure 105 illustrates the general arrangement of pinion shaft and bearings. The pinion shaft extends beyond the outer bearing and carries G2 as a cantilever, but this loading does not in

this particular case materially affect the shaft stresses.

The working stresses given below may be used to govern the design of shafting for work of this character. It is observed that these values are rather higher than employed for ordinary mill and shop work. This is due to the highly intermittent character of the duty with consequent reduction in the amount of wear and to the very rigid assumptions as to wind loading.

Speed of shafting, revolutions per minute.	Allowable stress in bending (lb. per sq. in.)		Allowable shearing stress (lb. per sq. in.)	
	10-lb. wind loads	15-lb. wind loads	10-lb. wind loads	15-lb. wind loads
Less than 20.....	14,000	16,000	10,000	12,000
20 to 50.....	12,000	14,000		
50 to 100.....	10,000	12,000		
Over 100.....	8,000	10,000	8,000	10,000

The maximum bending moment M_b at the center of the main pinion is readily seen to be

$$(R_1)(22) = (84,000)\left(\frac{23\frac{1}{2}}{45\frac{1}{2}}\right)(22) = 955,000 \text{ in.-lb.}$$

TABLE OF GEAR CALCULATIONS

Gear Number	Circular pitch (inches)	Diametral pitch	Number of teeth	Pitch diameter (inches)	Rev. per min.	Tooth speed (ft. per min.)	Estimated efficiency, gear and journal (per cent)	Total pressures		Torque on shafting (in.-lb.)	Lewis formula factor	Type of tooth, deg. involute	Material	Face width (inches)	Unit stress (pounds)
								Without gear friction (pounds)	Including gear friction (pounds)						
Rack G1	3½	216.000	14.65	84,000	20	cast steel	11½	14,700
	3¼	...	16	17.825	3.15	14.65	84,000	750,000	0.094	20	forged steel	11	23,200
G2	2¼	...	90	60.877	3.15	50.00	93	24,600	26,500	802,000	0.141	20	cast steel	4½	19,600
	2½	...	15	10.146	18.90	50.00	..	24,600	26,500	134,200	0.091	20	forged steel	6½	20,800
G4	1.57	2	64	32.000	18.90	158.00	95	2(8,400) ¹	2(8,850) ¹	2(142,000)	0.115	14½	cast steel	5	19,600
	1.57	2	18	9.000	67.00	158.00	..	2(8,400)	2(8,850)	2(40,000)	0.083	14½	forged steel	7	19,300
G6	1.57	2	64	32.000	67.00	560.00	95	2(2,500)	2(2,620)	2(42,000)	0.115	14½	cast steel	3½	8,300
	1.57	2	18	9.000	238.00	560.00	..	2(2,500)	2(2,620)	2(11,800)	0.083	14½	forged steel	4	10,080
G8	1.05	3	96	32.000	238.00	2,000.00	95	2(735)	2(775)	2(12,400)	0.118	14½	cast steel	3½	3,580
	1.05	3	21	7.000	1,090.00	2,000.00	..	2(735)	2(775)	2(2,710) ²	0.092	14½	forged steel	5	3,200

¹ Gears G1 to G3 carry the stress from one rack while gears G4 to G9 operate under the load from both racks, hence the multiplier of two in columns 9 and 10.
² As a check: 2,710 in.-lb. (or 225 ft.-lb.) multiplied by the gear ratio 346 = 78,000 ft.-lb. (approx.) at pinion (see table of maximum horse power and torques).

The stress due to bending above is found from the formula

$$f = \frac{M_b c}{I} = \frac{32M_b}{\pi d^3}$$

I = the moment of inertia = $\frac{\pi d^4}{64}$ for circular shafts and $c = \frac{d}{2}$

Assuming a 10-in. shaft (allowing $\frac{3}{4}$ in. for keyway)

$$f = \frac{(32)(955,000)}{(\pi)(9.25)^3} = 12,300 \text{ lb.}$$

The maximum torque or twisting moment, M_t , has already been calculated being $(84,000)(8.912) = 750,000$ in.-lb. The shearing stress due to this twisting moment alone is found from the formula

$$f_s = \frac{M_t c}{I_p}$$

where I_p represents the polar moment of inertia = $\frac{\pi d^4}{32}$ for circular shafts.

Whence

$$f_s = \frac{16M_t}{\pi d^3} = \frac{(16)(750,000)}{\pi(9.25)^3} = 4,830 \text{ lb.}$$

Where torsional and flexural forces exist simultaneously, as in this case, it can be easily shown that both the shearing and tensile (or compressive) stresses are increased, the maximum stresses occurring parallel and perpendicular to certain inclined shear planes. The maximum values are given by the formulas:

$$f_{\max.} = \frac{1}{2}(f + \sqrt{f^2 + 4f_s^2})$$

$$f_{s,\max.} = \frac{1}{2}\sqrt{f^2 + 4f_s^2}$$

Applying the formulas

$$f_{\max.} = \frac{1}{2} [12,300 + \sqrt{(12,300)^2 + 4(4,830)^2}] = 13,950 \text{ lb. per sq. in.}$$

$$f_{s,\max.} = \frac{1}{2} \sqrt{(12,300)^2 + 4(4,830)^2} = 7,800 \text{ lb. per sq. in.}$$

For torque only (which is the condition at the journal boxes) shearing stresses alone are developed, the value of which may be found as follows: Assuming a 7-in. shaft (neglecting keyway deductions)

$$f_s = \frac{16M_t}{\pi d^3} = \frac{(16)(750,000)}{(\pi)(343)} = 11,100 \text{ for a 15-lb. wind}$$

and

$$\frac{(16)(510,000)}{(\pi)(343)} = 7,550 \text{ for a 10-lb. wind}$$

The above stresses are lower than need be and it is quite possible to cut this shaft to a diameter of 9 in. at the center *A*, tapering to $6\frac{1}{2}$ in. at the bearing *B* without undue overstress.

43. Keys for Shaft S1.—The torque at the main pinion is 750,000 in.-lb. (see above). Reduced to periphery of the 9-in. shaft, the tangential force becomes

$$\frac{750,000}{4\frac{1}{2}} = 167,000 \text{ lb.}$$

Using two keys each as long as the pinion (11 in.) and assuming a working stress of 5,000 lb. per sq. in. in shear and 12,000 lb. per sq. in. in bearing, the dimensions of the keys are found as follows:

$$\begin{aligned} \text{Width (shear)} & \frac{167,000}{(2)(11)(5,000)} = 1.52 \text{ in.} \\ \text{Depth (bearing)} & \frac{167,000}{(2)(11)(12,000)} = 0.63 \text{ in.} \end{aligned}$$

Two keys $2 \times 1\frac{1}{4}$ in. are ample for this purpose.

44. Hand Operating Mechanism.—A bridge of this size, and powered as effectively and as certainly as this one, need rarely to be operated by hand power. Notwithstanding this fact some method of hand operation should be provided as emergency equipment.

It is impracticable to attempt to provide for hand operation against a wind pressure in excess of 5 lb. per sq. ft. or to attempt a gear reduction to reduce to torque beyond that which may reasonably be expected from four men.

The customary specification for hand power provides that each man be assumed to exert a sustained tangential force of 40 lb. and to travel at a rate of 160 ft. per min.

The maximum torque under a 5-lb. wind has been calculated to be 23,000 ft.-lb. At gear *G8* this torque becomes

$$(23,000) \left(\frac{\text{rev. per min. of pinion}}{\text{rev. per min. of gear } G8} \right) = \frac{(23,000)(3.15)}{238} = 305 \text{ ft.-lb. for}$$

one truss, or 610 ft.-lb. for one leaf.

The above value does not include the power absorbed by the gear and journal friction between the main pinion and the capstan lever. Assuming an efficiency of 90 per cent (since the gears are moving slowly) for each pair of spur gears and an efficiency of 85 per cent of each pair of bevel or miter gears, the over all efficiency becomes

$$(0.90)^2 (0.85)^2 = 0.45$$

The applied torque is therefore

$$\frac{610}{0.45} = 1,360 \text{ ft.-lb.}$$

Four men each at the end of a 4-ft. lever exert a combined torque of

$$(4)(4)(40) = 640 \text{ ft.-lb.}$$

The gear reduction between $G8$ and the capstan shaft must, therefore, be

$$\frac{1,360}{640} = 2.2 \text{ (approx.)}$$

By making gear $G10$ with 48 teeth and gear $G11$ with 19 teeth, a reduction of $\frac{48}{19}$ or 2.5 is effected, which seems to meet the requirements. No further gear reduction is needed and the other bevel gears are made miter gears (speed ratio = 1.0) and serve only to transmit the power to a location convenient for the capstan shaft.

During the opening of the bridge the main drive pinion travels approximately 11 ft. (linear distance), or

$$(11)(1\frac{1}{2})(3\frac{1}{2}) = 2.36 \text{ rev.}$$

The gear reduction between this pinion and the hand turning shaft is

$$(\frac{90}{15})(\frac{64}{18})(\frac{64}{18})(\frac{48}{19}) = 190 \text{ (approx.)}$$

and the turning shaft will, therefore, need to make $(2.36)(190)$, or 448 rev. Each man at the end of the 4-ft. lever will travel $(448)(2\pi)(4)$, or 11,300 ft. The time of opening by hand is, therefore,

$$\frac{11,300}{160} = 70 \text{ min. (approx.)}$$

45. Center Lock Mechanism.—The center lock is designed to lock the two leaves together in their closed position and is proportioned to

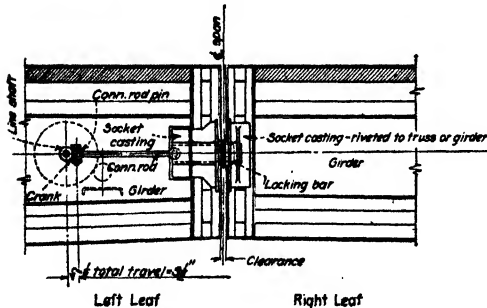

FIG. 106.

transmit a certain predetermined shearing stress from one leaf to the other. In this case the center lock is proportioned to transmit a shearing stress of 20,000 lb. and consists of a cast steel bar sliding in and out of a cast steel socket riveted to the sides of the truss.

The locking bar must act as a cantilever between the point of application of the socket pressure and its point of support. This latter point is rather hard to locate exactly. Assuming a length of cantilever of 10 in., the bar must be designed to resist 20,000 lb. in shear and $(20,000)(10) = 200,000$ in.-lb. in bending.

The general arrangement of center lock pin and socket is shown in Fig. 106. The socket castings are designed more from a sense of pro-

portion than from any set formulas and the riveting is designed to develop the full strength of the locking bar.

46. Motor Power Required for Center Lock.—The total shearing stress (two trusses) transmitted by the center lock has been assumed as 40,000 lb. Using an assumed coefficient of friction of 30 per cent (which is a safe assumption) the pull on the center lock will be 30 per cent of 40,000 lb. = 12,000 lb. The duration of the operation of locking or

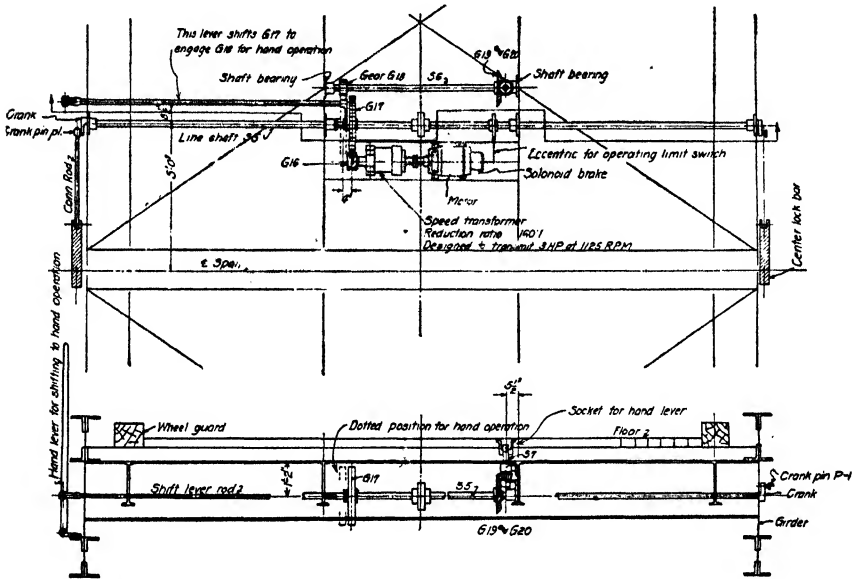

FIG. 107.

unlocking the bridge should probably not exceed 12 sec. and since the total travel of the locking pins (see Fig. 106) will be about 7 in., the power developed is

$$\frac{(12,000)(7)}{12} = 7,000 \text{ in.-lb. per sec.}$$

or

$$\frac{(7,000)(60)}{12} = 35,000 \text{ ft.-lb. per min.}$$

or

$$\frac{35,000}{33,000} = 1.01 \text{ h.p.}$$

Assuming an overall efficiency of the transmitting mechanism of 60 per cent, the theoretical power required is

$$\frac{1.01}{0.60} = 1.7 \text{ h.p. (approx.)}$$

The most efficient method of operating the center locking device is by means of a small electric motor placed at the end of the leaf, as shown in Fig. 107. The motor selected in this case will be a 3-h.p. A.C. motor running at a full load speed of 1,125 rev. per min. which will afford about 75 per cent excess power. It is of course not necessary to adopt a

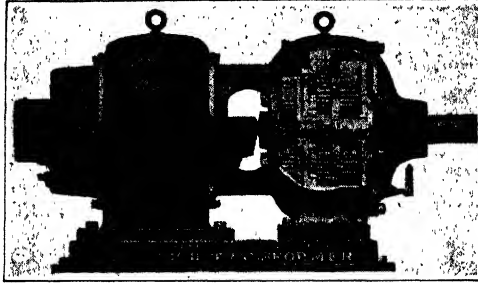

(Courtesy of Foote Bros. Gear & Machine Co., Chicago, Ill.)

FIG. 108.—Foote spur gear speed transformer and direct connected electric motor.

power unit as large as this but the difference in cost between a 3-h.p. and a 2-h.p. motor is so small that it hardly pays to risk burning out or stalling the motor in case the locking pin should become jammed.

The complete operation of locking or unlocking the bridge requires a one-half revolution of the crank shaft, and consumes a time interval

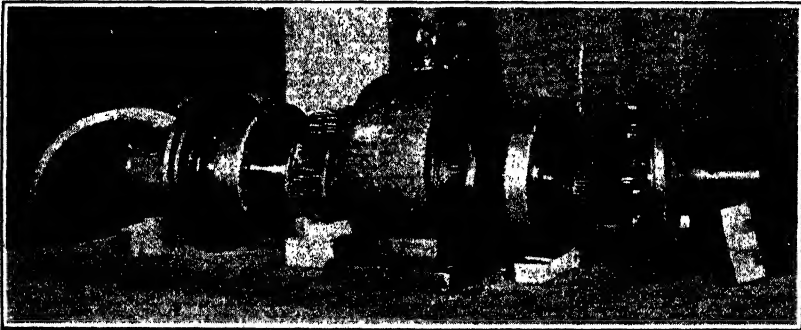

(Courtesy of Foote Bros. Gear & Machine Co., Chicago, Ill.)

FIG. 109.—Assembly view of Foote spur gear speed transformer.

of 12 sec. During this time the motor makes approximately $(1,125) \left(\frac{12}{60}\right) = 225$ rev. The gear reduction necessary is therefore $225 \div \frac{1}{2} = 450$.

The problem then resolves itself into that of designing a train of gears to accomplish the above reduction with due simplicity and without

the necessity for a large number of exposed moving parts. A spur gear reduction of 3:1 together with a "speed transformer" having a speed ratio of 160:1 solves the problem and is the solution adopted in this case (see Fig. 107).

There are several types of commercial reduction gears on the market, some involving the planetary principle and others involving nothing other than a train of spur gears so arranged that the driving and driven shaft are concentric one with another, this latter type giving much better service. The bridge engineer is not vitally interested in the design of the internal mechanism of a reduction gear of this kind any more than he is with the internal design of an electric motor. The gear may be ordered from the manufacturer to transmit a given horsepower at a given speed

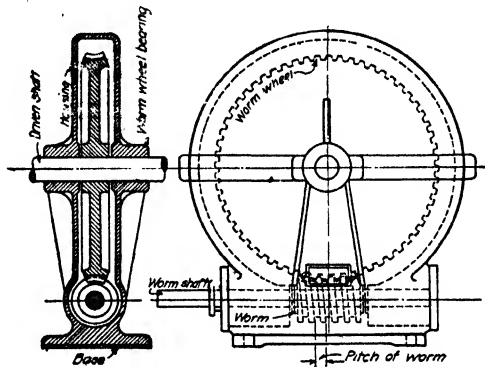

FIG. 110.—Diagram of worm gear speed transformer.

in revolutions per minute of the driving shaft and with a given speed reduction ratio.

The advantage of a compact reduction gear of the type above described (see Fig. 108) may be summarized as follows:

- (1) Great strength and durability.
- (2) Enclosed, oil tight and dust proof gear box, free from the danger of grit.
- (3) Freedom from the danger, and from the noise of exposed gearing.
- (4) Compactness.

This type of transmission is used for powers from 1 h.p. to 100 h.p. and for reduction ratios from 1:4 to 1:325 and above.

For reduction duty of this kind, worm gear speed transformers are also sometimes employed. The spur gear variety are to be preferred, however, because of the higher efficiency and the lessened need for constant attention as regards lubrication.

It is noted from Fig. 110, that for every revolution of a single threaded worm, the worm wheel travels forward by one tooth. The speed ratio

for a single thread worm is, therefore, equal to the number of teeth in the worm wheel. The general expression for any type worm is

$$\text{Speed ratio} = \frac{\text{number of teeth in worm wheel}}{\text{number of threads in worm}}$$

It is not necessary as a general rule for the bridge engineer to design his worm drive transmission, the problem being one of selection from the standard manufacturers' lists.

The following table is typical of those to be found in any manufacturer's list and serves to illustrate the point:

TABLE OF DIMENSIONS AND PROPERTIES FOOTE BROS. WORM GEAR TRANSMISSIONS
(Courtesy of Foote Bros. Gear & Machine Co., Chicago, U. S. A.)

Style number.....	20W	20W	20W	20W	20W	20W	20W	20W
Ratio.....	28	33.33	35	42	50	70	84	100
Safe load in pounds at... pitch line at this revo- lutions per minute..	745	650	1030	1700	1530	1105	890	765
Pitch.....	$\frac{5}{8}CP$	6DP	$\frac{3}{4}CP$	$1\frac{1}{4}CP$	3DP	$\frac{3}{4}CP$	$\frac{5}{8}CP$	6DP
Safe load, pounds, stand- ing pressure.....	1,050	900	1,300	2,000	1,800	1,300	1,050	900
Horse power.....	2.00	1.33	2.50	4.75	3.50	1.87	1.25	0.87
Pitch diameter of gear...	16.71	16.66	16.71	16.71	16.66	16.71	16.71	16.66
Number of teeth.....	84	100	70	42	50	70	84	100
Face.....	$2\frac{3}{4}$	$2\frac{3}{4}$	$2\frac{3}{4}$	$2\frac{3}{4}$	$2\frac{3}{4}$	$2\frac{3}{4}$	$2\frac{3}{4}$	$2\frac{3}{4}$
Largest gear shaft.....	$2\frac{3}{16}$	$2\frac{3}{16}$	$2\frac{3}{16}$	$2\frac{3}{16}$	$2\frac{3}{16}$	$2\frac{3}{16}$	$2\frac{3}{16}$	$2\frac{3}{16}$
Largest worm shaft.....	$1\frac{1}{16}$	$1\frac{1}{16}$	$1\frac{1}{16}$	$1\frac{1}{16}$	$1\frac{1}{16}$	$1\frac{1}{16}$	$1\frac{1}{16}$	$1\frac{1}{16}$
Center to center <i>W</i> and <i>G</i> ..	10	10	10	10	10	10	10	10
Threads in worm.....	Trip.	Trip.	Doub.	Sing.	Sing.	Sing.	Sing.	Sing.
Pitch diameter of worm..	3.29	3.33	3.29	3.29	3.33	3.29	3.29	3.33

It is noted that the reduction desired, 1:160, is rather greater than any of the worm transmissions listed in the table for which reason another pair of spur gears should probably be employed.

Assume that the style shown in the above table is tentatively selected, the one having a speed ratio of 50 being chosen. The normal revolutions per minute as listed is 750. If a pair of spur gears is introduced between the worm shaft and the motor with a ratio of approximately $1\frac{1}{2} : 1$, then when the motor is running at full load speed the worm will be making $1,125 \div 1\frac{1}{2}$, or 750 rev. per min., and the worm wheel will be making $750/50$, or 15 rev. per min.

The safe load at the pitch circle of the worm wheel at this speed is given by the table as 1,530 lb. The radius of the worm wheel is 8.33

in. or 0.7 ft. (approx.). The power which may be safely transmitted to the worm wheel shaft is, therefore,

$$\frac{(1,530)(0.7)(2\pi)(15)}{33,000} = 3 \text{ h.p.}$$

which is ample for this purpose.

This worm may be used, therefore, for this service providing a spur gear reduction of $450 \div (50)(1\frac{1}{2}) = 6:1$ is used between the worm transmission and the crankshaft.

The installation, using this type of transmission, takes more power, as the efficiency is much lower, and is also much more cumbersome and bulky than the spur gear reduction first described.

47. Design of Center Lock Shafting.—The line shafting S5 (Fig. 107) is designed by the formula used for the design of the main pinion shaft, the result showing a $2\frac{1}{16}$ -in. cold rolled shaft to be necessary.

48. Design of Pin (P1) in Crank.—Let us assume a pin of $1\frac{3}{4}$ in. diameter, and a connecting rod lead thickness of $1\frac{3}{4}$ in. This pin transmits a connecting rod stress of $\frac{12,000}{2} = 6,000$ lb. and a bending moment of $(6,000)(1\frac{3}{4}) \div 2 = 5,250$ in.-lb. From these data we find

$$\text{Unit bearing stress} = \frac{6,000}{(1\frac{3}{4})(1\frac{3}{4})} = 1,950 \text{ lb. per sq. in.}$$

$$\text{Unit fiber stress in bending} = \frac{(5,250)(32)}{(\pi)(1\frac{3}{4})^3} = 10,000 \text{ lb. per sq. in.}$$

The above unit bearing stress would be high for a shaft bearing but this load is highly intermittent, and the motion very slow, and of short duration, consequently the load conditions partake of the nature of static stresses for which the value 1,950 lb. per sq. in. is very low.

The key for attaching the crank to the drive shaft is designed as follows:

$$\text{Torque on drive shaft} = (6,000)(3\frac{1}{2}) = 21,000 \text{ in.-lb.}$$

$$\text{Radius of drive shaft} = 1.35 \text{ in.}$$

$$\text{Tangential shear} = 21,000 \div 1.35 = 15,500 \text{ lb.}$$

Using a square key ($\frac{7}{8}$)($\frac{7}{8}$ in.)

$$\text{Unit shear} = \frac{15,500}{(\frac{7}{8})(2\frac{1}{2})} = 7,100 \text{ lb.}$$

$$\text{Unit bearing} = \frac{15,500}{(2)(\frac{7}{16})} = 14,200 \text{ lb.}$$

These stresses are higher than usually allowed for line shafting (see Art. 43) but may be used here in view of the short duration and intermittent character of the load as above noted.

49. Design of Gearing for Center Lock Drive.—Gears *G16* and *G17* are designed exactly as hereinbefore outlined with the following results:

<i>G16</i>	
Diametral pitch.....	3
Number of teeth.....	18
Pitch diameter.....	6 in.
14½-deg. involute teeth	
Face width.....	3½ in.
<i>G17</i>	
Diametral pitch.....	3
Number of teeth.....	72
Pitch diameter.....	24 in.
14½-deg. involute teeth	
Face width.....	3 in.

Gear *G18* will be practically the same as *G16*, except that *G18* has 15 teeth.

The bevel gears *G19* and *G20* are designed as follows:

$$\text{Torque on shaft } S6 = (2)(21,000)(15\sqrt{2}) = 8,750 \text{ in.-lb.}$$

Assuming one man to operate at the end of a 5-ft. lever, exerting an average tangential force of 50 lb., the torque developed is $(50)(60) = 3,000$ in.-lb. The gear reduction needed is therefore

$$8,750 \div 3,000 = 2.92$$

The bevel gears *G19* and *G20* are designed exactly as if they were spur gears, except that the allowable unit stresses assumed in the design are generally taken as 75 per cent of the values adopted for spur gearing. Assume a 2-in. face and a circular pitch of $1\frac{1}{4}$ in. For *G19* use 15 teeth and for *G20* use 45 teeth (which gives the required reduction 3:1). The pitch diameter of *G19* is 5.968 in. and that of *G20* is 17.905 in. The tooth speed for this pair of gears is, by inspection, about 8 ft. per min. The unit stresses for cast iron gears should therefore not exceed about 75 per cent of 7,000, or 5,250 lb. per sq. in. (see table on p. 132).

$$\text{The tooth pressure at the pitch cone is } 3,000 \div \frac{5.968}{2} = 1,000 \text{ lb.}$$

(approx.). Applying the Lewis formula

$$f = \frac{1,000}{(2)(1\frac{1}{4})(0.075)} = 5,330 \text{ lb. per sq. in. for } G19$$

and

$$f = \frac{1,000}{(2)(1\frac{1}{4})(0.111)} = 3,640 \text{ lb. per sq. in. for } G20$$

These values are practically within the above allowable stress limits.

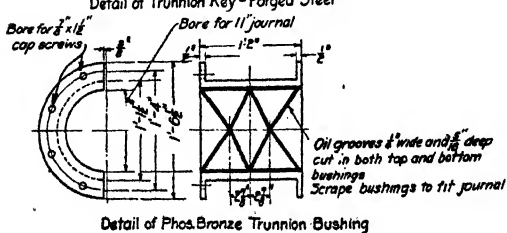
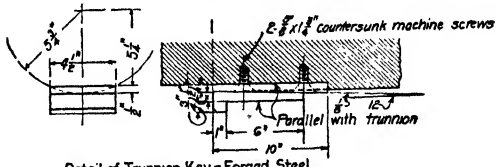
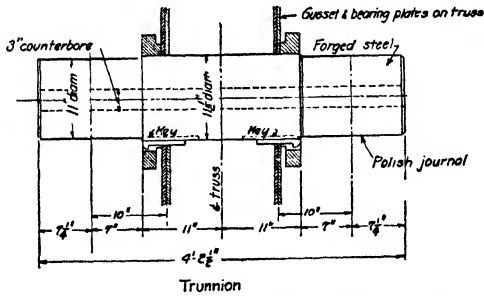
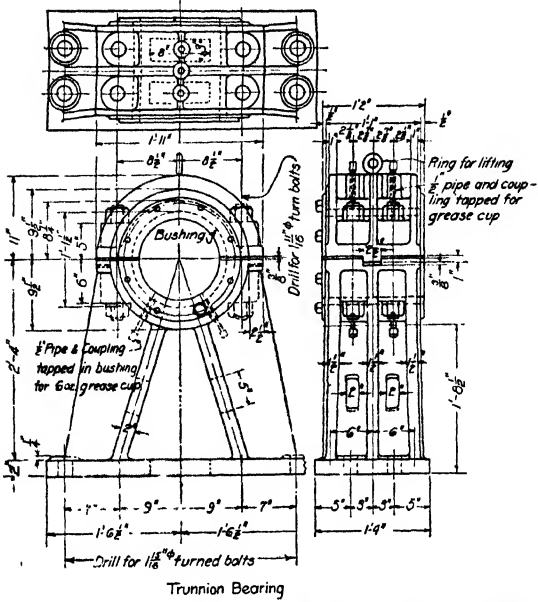

FIG. 111.

The horizontal and vertical shafts *S6* and *S7* are calculated in the ordinary manner, hereinbefore described.

50. Calculation for Bearings for Main Pinion Shaft.—The outer bearing for the main pinion shaft must be designed to carry the reaction from the main pinion and also from gear *G2* (see Fig. 105). The pinion reaction is 84,000 lb. and the reaction from gear *G3* transmitted to gear *G2* is 26,500 lb. (see table of gear stresses). The maximum bearing reaction, assuming both the above forces to be in the same plane, which is nearly true for this case, and neglecting the dead load of the gears, is given by the expression

$$R_2 = \frac{(84,000)(22) + (26,500)(53\frac{1}{2})}{45\frac{1}{2}} = 72,000 \text{ lb.}$$

For phosphor bronze bushings and slow motion the allowable bearing pressure is generally taken at a value between 1,000 and 1,200 lb. per sq. in. For the *very* slow motion in this case the working pressure may be taken as high as 1,400 lb. per sq. in. from which the necessary bearing width is found to be

$$\frac{72,000}{(6\frac{1}{2})(1,400)} = 8 \text{ in. (approx.)}$$

In this case a 9-in. bearing will be used. This width is ample to care for the dead load of the gears, etc. In this manner the other bearings are designed.

For heavy duty work, in designs of this character, phosphor bronze bushings are generally employed. For low pressure duty babbitted bearings may be used, as shown in Fig. 116. The phosphor bronze bushings may be detailed as shown in Fig. 111, or, for lighter duty, may be babbitted in place. The bushings are scraped to fit the journal and oil grooves are cut for both top and bottom bushings.

A good bearing should combine the following qualities:

- (1) Minimum wear.
- (2) Provision for easy adjustment to line and elevation.
- (3) Provision for removal with a minimum disturbance to the rest of the machinery.
- (4) Adequate and positive lubrication.

The two-halves of the bushings are so constructed as to permit adjustment by means of brass shims or liners and the lubrication is effected by means of grease cups (see Fig. 111). Bearings for bevel gears should be constructed as a unit wherever possible in order to eliminate the tendency for such gears to spread under service.

51. Design for Main Trunnions.—The load on the main trunnion is the resultant of: (1) The dead load of entire bascule leaf, (2) the maxi-

mum wind load, and (3) the pinion reaction. The resultant of these three forces may be obtained either analytically or graphically (as per Fig. 112) and is found to be 435,000 lb. for each trunnion.

A trunnion diameter of 11 in. was originally assumed for the calculation of trunnion friction using a rough method of calculation (see Art. 38c). With more complete and exact data now at hand we may compute the exact size of trunnion needed.

The total area required for each bearing, using a working value of 1,700 lb. per sq. in. for bearing on phosphor bronze is

$$\frac{435,000}{(2)(1,700)} = 128 \text{ sq. in.}$$

A journal box of 14 in. total length will require a trunnion diameter of $\frac{128}{14} = 9.2$ in. A diameter of 10 in. is therefore sufficient as regards bearing.

The thickness of the structural steel bearing on this trunnion is $1\frac{1}{2}$ in. for each web, or 3 in. for each trunnion. The bearing stress on the structural steel is, therefore,

$$\frac{435,000}{(10)(3)} = 14,500 \text{ lb. per sq. in.}$$

which is also satisfactory.

Assuming the reaction from the truss to be concentrated at the center of the web, and the load transmitted to the trunnions to be concentrated at the center of the trunnion bearings (see Fig. 110), the trunnion is under a bending moment of

$$\left(\frac{435,000}{2}\right) (10) = 2,175,000 \text{ in.-lb.}$$

The unit fiber stress in bending is, therefore,

$$f = \frac{32M}{\pi d^3} = \frac{(32)(2,175,000)}{\pi(10)^3} = 22,100 \text{ lb.}$$

This is about 30 per cent high, but the condition is remote and a 10-in. trunnion would probably give excellent service.

For trunnions above 8 in. in diameter, however, it is customary to specify a counterbore not less than one-fourth the diameter of the trunnion. If the 10-in. trunnion above is counterbored, the stresses will be even

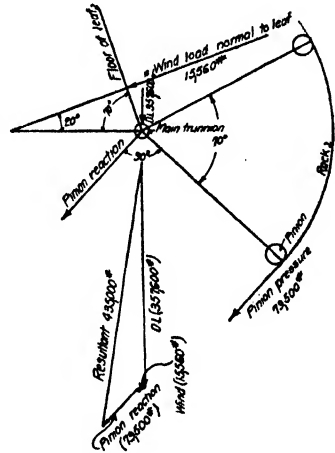

FIG. 112.—Trunnion stresses.

higher than those noted. Let us, therefore, try a trunnion 11 in. in diameter with a 3-in. counterbore. Then

$$f_s = \frac{Mc}{I}$$

$$c = \frac{d}{2} \text{ and } I = \frac{\pi(d^4 - d_1^4)}{64}$$

$$f_s = \frac{32M}{\pi(d^4 - d_1^4)} = \frac{(32)(2,175,000)}{\pi\left(\frac{11^4 - 3^4}{11}\right)} = 16,900 \text{ lb. per sq. in.}$$

We will use this dimension for our trunnion (as shown in Fig. 111).

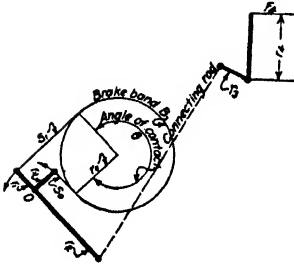

FIG. 113.

52. Design of Hand Brakes.—The general arrangement of brake band and levers which will be employed in this case, is shown in Fig. 113. When a force F is applied at the end of the hand lever, the sum of the tensions S_0 and S_1 in the brake band, B , is found from the expression

$$(S_0 + S_1)r_1 = \frac{Fr_2r_3}{r_3}$$

or

$$S_0 + S_1 = \frac{Fr_2r_3}{r_3r_1} \quad (A)$$

It may be easily shown¹ that for "impending slip"

$$\frac{S_1}{S_0} = e^{f\theta}$$

¹ Consider the brake band shown in Fig. 114. Let

- p = the unit normal pressure at any point.
- S = the tension in the brake band.
- r = the radius of the brake drum.
- f = the coefficient of friction.
- F = the total friction $\Sigma fpds$.

Then from elementary mechanics

$$p = \frac{S}{r}$$

Also from the figure

$$\frac{dF}{ds} = fpds = dS$$

$$\frac{dS}{S} = \frac{fpds}{S} = \frac{fpr d\theta}{S} = \frac{fd\theta(pr)}{S} = fd\theta$$

or

$$\frac{dS}{S} = fd\theta$$

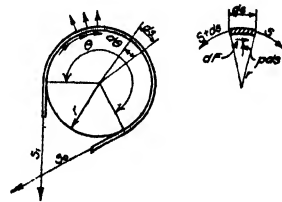

FIG. 114.

or

Integrating each side

$$\int_{s_0}^{s_1} \frac{dS}{S} = f\theta$$

or

$$\log_e S_1 - \log_e S_0 = f\theta$$

That is,

$$\frac{S_1}{S_0} = e^{f\theta}$$

where e = the naperian base = 2.71828.
 f = the coefficient of friction.
 θ = the angle of contact in radians.

Substituting for S_1 in Eq. (A) above, we have

$$S_0(1 + e^{\theta f}) = \frac{Fr_4r_2}{r_3r_1}$$

The torque on the brake band is easily seen to be

$$(S_1 - S_0)r_0 = S_0(e^{f\theta} - 1)r_0$$

whence by substitution

$$T_B \text{ (the braking torque)} = \left(\frac{Fr_4r_2}{r_1r_3}\right)\left(\frac{e^{f\theta} - 1}{e^{f\theta} + 1}\right)r_0$$

For the various angles of contact the values $e^{f\theta}$ for an assumed coefficient of friction of 20 per cent are worked out for ready use in the table below.

VALUE OF θ , DEGREES	VALUE OF $e^{f\theta} = e^{0.20\theta}$
140	1.63
160	1.74
180	1.87
200	2.01
220	2.16
240	2.31
270	2.57
300	2.85

With the above data at hand we are now ready to take up the design of the brake lever system.

The braking torque necessary to hold the span against a 15-lb. wind is obviously

$$(76,200)(8.912) = 679,000 \text{ in.-lb. (approx.)}$$

on the main pinion shaft.

Reduced to the speed of shaft S_3 the braking torque becomes

$$679,000\left(\frac{G_3}{G_2}\right)\left(\frac{G_5}{G_4}\right) = 679,000\left(\frac{15}{90}\right)\left(\frac{18}{64}\right) = 31,800 \text{ in.-lb. for one truss}$$

or

$$(2)(31,800) = 63,600 \text{ in.-lb. for one leaf}$$

The system of brake levers should be sufficient to develop this braking torque in an emergency using, as a basis of calculation, a maximum pull at the end of the brake lever equal to twice the normal, or 100 lb. Assuming the following dimensions for the system in question: $r_1 = 3$ in.,

$r_2 = 20$ in., $r_3 = 4$ in., $r_4 = 60$ in., $r_0 = 15$ in., $e^{f\theta} = 2.57$, and $F = 100$ lb., we find the braking torque to be

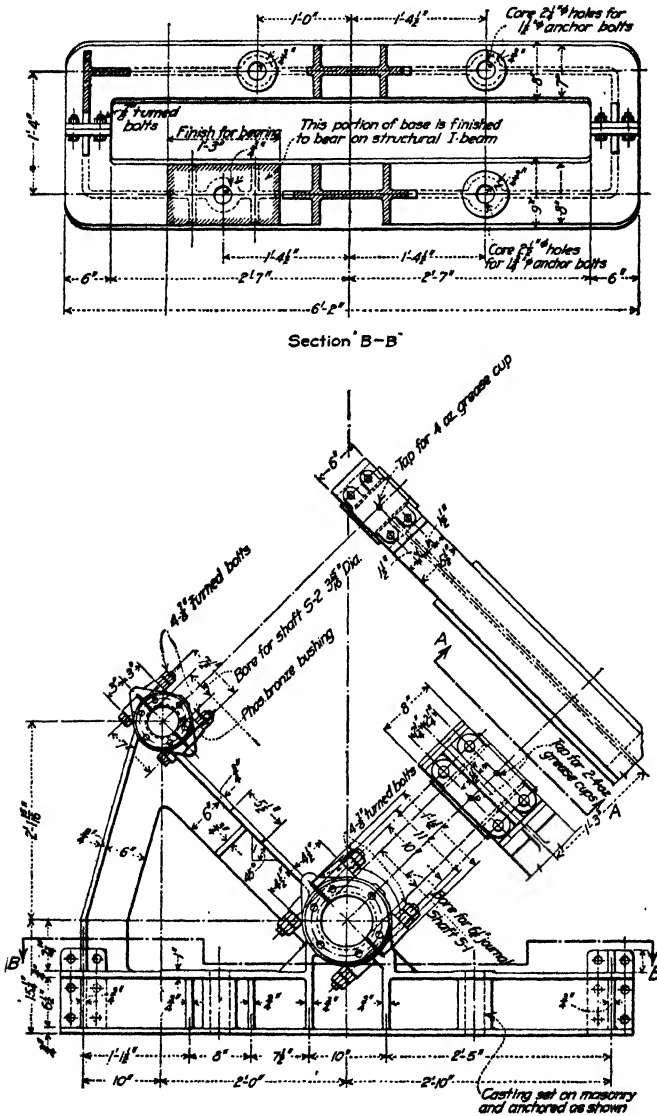

Fig. 115.—Cast machinery frame. For {shafts S1 and S2} see Fig. 104. {gears G2 and G3}

$$T_B = \left[\frac{(100)(60)(20)}{(4)(3)} \right] \left[\frac{2.57 - 1}{2.57 + 1} \right] (15) = 66,000 \text{ in.-lb.}$$

which meets all requirements.

It only remains to design the levers, cranks, pins, and connecting rods, which form the system, in such manner as to safely carry the stresses imposed and also to design the band sufficiently wide to prevent burning out.

The design of the levers, cranks and pins need not be discussed further except to state that low unit stresses should always be adopted as a

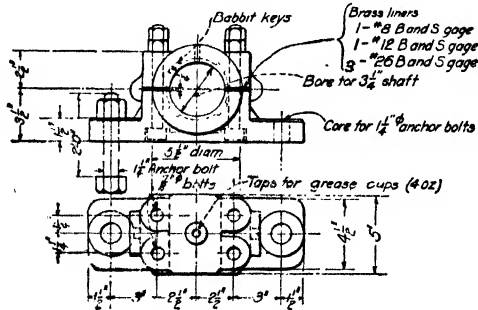

FIG. 116.—Typical babbitted bearing.

breakdown of this equipment during an emergency would prove disastrous indeed.

If p is the unit pressure on the brake band in pounds per square inch, and v is the velocity of the rim of the brake wheel in feet per second, the value pv for work of this character should not exceed 18 to 20, otherwise the brake lining is likely to become injuriously heated under service and to burn out. The above applies to the timber block type of brake lining which is the type used in this case. For brakes running in an oil bath, etc. a higher value of the term pv may be used.

RECENT DEVELOPMENTS AFFECTING DESIGN

The types and basic design of bascule bridges have not materially changed since 1920. During the past twenty years, however, there has been a definite trend toward uniform highway design specifications with a general increase in the permissible unit stresses. The introduction of light floors for highway bridges, particularly the open steel type, has effected considerable savings in movable and long spans.

The permissible unit stresses and the effect of an open type steel floor on some portions of the bascule highway bridge shown in Fig. 99 will be presented in the following articles.

53. Permissible Unit Stresses.—The size and make-up of each member shall be proportioned for stresses due to the following loads and combinations of loads:

Case I—Dead Load.—Bridge open in any position.

Case II—Dead Load.—Bridge closed.

Case III—Wind Load.—Bridge open in any position with a force due to wind and lateral vibration acting thereon.

Case IV—Live Load.—Bridge closed with normal live loads acting thereon.

The following combinations of loads shall be used for determining maximum stresses:

Case I only, plus 20 per cent.

Case I, plus 20 per cent with Case 3.

Case II with Case IV.

53a. Permissible Unit Stresses in Concrete, in Pounds per Square Inch.

Extreme fiber stress (flexure and direct stress).....	1,000
Tension in reinforced members.....	None
Shear in beams without web reinforcement:	
Longitudinal bars not anchored.....	60
Longitudinal bars anchored.....	90
Shear in beams with web reinforcement:	
Longitudinal bars not anchored.....	140
Longitudinal bars anchored.....	180
Punching shear.....	160

53b. Permissible Unit Stresses in Reinforcing Steel, in Pounds per Square Inch.

Tension in flexural members.....	18,000
Tension in web reinforcements.....	16,000
Compression.....	n times the compression in the surrounding concrete
Bond on bars not anchored.....	100
Bond on bars adequately anchored.....	150

The value of n shall be 10 for concrete having an ultimate compressive strength of 3,000 lb. per sq. in. at 28 days, and 12 for all concretes of lesser strength.

53c. Permissible Unit Stresses in Structural Steel, in Pounds per Square Inch.

Structural carbon steel (See A.S.T.M.: A7)

Rivet steel (See A.S.T.M.: A141)

Pins and rollers (See A.S.T.M.: A235, Class CI)

Axial tension, structural steel, net section.. 18,000

Tension in extreme fibers of rolled shapes, girders, and built-up sections subject to bending..... 18,000

Tension in bolts at root of thread....	13,500	
Compression members centrally loaded with L/r not greater than 140:		
Riveted ends.....	15,000	$-\frac{1}{4}\frac{L^2}{r^2}$
Pin ends.....	15,000	$-\frac{1}{3}\frac{L^2}{r^2}$

where L = length, in inches, of member.

r = least radius of gyration, in inches, of member.

Compression in splice material, gross section.....	18,000
Shear in extreme fiber of pins.....	27,000
Shear in plate girder webs, gross section....	11,000
Diagonal tension in webs of girders and rolled beams, at sections where maximum shear and bending occur simultaneously.....	18,000
Shear in power-driven rivets and pins.....	13,500
Shear in turned bolts.....	11,000
Bearing on pins.....	24,000
Bearing on power-driven rivets, milled stiffeners, and other steel parts in contact....	27,000
Bearing on pins subject to rotation.....	12,000
Bearing on turned bolts.....	20,000
Bearing on expansion rollers and rockers, pounds per linear inch:	

Diameters up to 25 in. $\frac{P - 13,000}{20,000}600d$

Diameters from 25 to 125 in.
 $\frac{P - 13,000}{20,000}3,000\sqrt{d}$

where d = diameter, in inches, of roller or rocker.

p = yield point in tension of steel in the roller or the base, whichever is smaller.

These permissible unit stresses conform to those recommended by the 1941 design specifications of the American Association of State Highway Officials. The reader is referred to these specifications for additional information relative to design.

54. Effect of Light Floors.—An application of the light open type steel floor, using the permissible unit stresses given in Art. 53, to the floor system of the bascule highway bridge shown in Fig. 99 will be considered. No change will be made in the live load assumptions. An open

type steel floor 5 in. in depth is satisfactory for the live load with stringers 5 ft. on centers.

D.L. (floor).....	19 lb. per sq. ft.	
D.L. (floor).....	95 lb. per lin. ft. of stringer.	
D.L. (stringer).....	30 lb. per lin. ft. of stringer.	
D.L. moment.....	3.63 kip-ft.	Required section modulus . . 2.6 in. ³
L.L. moment.....	39.20 kip-ft.	
Impact 30 per cent.	<u>11.80 kip-ft.</u>	
Total.....	51.00 kip-ft.	Required section modulus 34.9 in. ³

A 14-in. WF 30-lb. beam, having a section modulus of 41.8 in.³ will be satisfactory and will be used for the stringers.

The bending moments in the intermediate floor beams and the required size of beam are:

D.L. moment (stringer).....	24.9 kip-ft.	
D.L. moment (floor beam)....	<u>4.8 kip-ft.</u>	
Total.....	29.7 kip-ft.	Required section modulus . . 19.8 in. ³
L.L. moment.....	153.0 kip-ft.	
Impact 29 per cent	<u>44.4 kip-ft.</u>	
Total.....	197.4 kip-ft.	Required section modulus 131.6 in. ³

A 24-in. WF 74-lb. beam, having a section modulus of 170.4 in.³, will be selected for the floor beam. The dead load reaction of this floor beam is 5.04 kips as compared with 7.84 kips in the original design, a reduction of one-third. Thus, it may be seen that a considerable saving in weight can be secured by use of the light open steel flooring. This in turn results in a reduction in the required volume of concrete in the counterweight which is dependent on the dead load of the river arm.

There are two other characteristics of this type of flooring which are well worth consideration in highway bascule bridge design. For bridges of this type located in regions where heavy snowfalls may be anticipated, the fact that a very small portion of snow will be retained on the floor system permits of a more nearly balanced dead load throughout the year. It is also obvious that wind loads on the open type flooring will be much less than on a closed or solid type. The exposed area of the open flooring and floor system is usually less than 50 per cent of that of the solid flooring. It was shown in Art. 38d that a 15-lb. wind assumption on a solid floor constitutes about 95 per cent of the entire force to be handled by the operating machinery of the bridge under consideration. As the exposed area of the upper chords of the main trusses

amounts to about 12 to 13 per cent of the total exposed area, it is clear that if an open type of flooring had been available when this bridge was designed a material saving in structural steel and operating machinery could have been made. It is also probable that the cost would have been reduced. It should be borne in mind, however, that cost of the open type flooring will be at least three times as much as that of the solid type flooring used in the original design.

SECTION 2

VERTICAL LIFT BRIDGES

Vertical lift bridges of small spans and low lifts were constructed in Europe at a fairly early date. No vertical lift bridges of any size, however, were constructed there until recent years. In 1850 Capt. W. Morson, an Englishman, designed a vertical lift bridge with a span of 100 ft. and a rise of 54 ft. for crossing the Rhine River at Cologne, but a competitor secured the prize in the competition in which the plans were entered. Oscar Roper of Hamburg in 1867 designed a bridge with a lifting span of 300 ft. and a high rise to allow the passage of ocean going vessels, but this bridge was never built.

Squire Whipple in 1872 began designing and building small vertical lift bridges to cross canals in New York. In 1892 Doctor Waddell designed a vertical lift bridge 250 ft. long with a rise of 140 ft. to span the ship canal at Duluth. This bridge was not built because of the objections of the War Department. The first vertical lift bridge of any importance to be built in this country probably was the South Halstead Street Bridge at Chicago. This bridge was designed by Doctor Waddell in 1892 and constructed shortly afterward. It had a span of 130 ft. and a maximum vertical clearance of 155 ft. For a period of 12 or 15 years after the construction of the Halstead Street Bridge very little progress was made in the construction of vertical lift bridges, but since 1908 many well designed and economical lift bridges of this type have been constructed, one engineering firm having designed and built about 40 of these bridges.

1. Advantages of Vertical Lift Bridges.—Compared with swing and bascule bridges, the vertical lift bridge has proved from data available to be economical both in construction and operation and there is no doubt but that many bridges of this type will be constructed in the future. Some of the advantages of the vertical lift bridge are as follows:

First Cost.—It seems to be generally admitted that the first cost of a vertical lift bridge is about the same as that of swing and bascule bridges having the same channel opening. For long spans and low lifts the vertical lift is cheaper, though it may be more expensive in cases of short spans and high lifts.

Simplicity.—The ordinary vertical lift bridge is simple to design and construct. The complicated details are comparatively few and present no difficult problems.

Rigidity.—The vertical lift is as rigid as other types of movable bridges.

Reliability.—The reliability of the vertical lift has been demonstrated many times. The South Halstead Street Bridge of Chicago in 1907 was said to be the most satisfactorily operating movable bridge in Chicago.

Ease of Operation.—A well designed vertical lift is as easy to operate as any other type of movable bridge.

Time of Operation.—The time required for a complete raising or lowering of a vertical lift bridge is usually about 45 to 50 sec. Of course the time required for a partial raising or lowering is less.

Duration of Opening.—The total time required for the opening of the bridge, the passage of the boat, and the closing of the bridge is less for the vertical lift and bascule than for the swing types because a boat will approach closer to the vertical lift or bascule bridge. The swing bridge requires considerable room for its swing and appears to obstruct the channel to a larger degree. Swing bridges must make a full opening each time, while the opening required for the bascule or vertical lift depends on the height of the vessel's masts. Hence, much less time is required for the passage of the smaller craft through the vertical lift and bascule bridges than for the swing bridges. This saving of time is well worth considering when the water or the land traffic (or both) is heavy.

Power Economy.—A well-designed vertical lift bridge seems to be just as economical of power as a bascule and more economical than a swing bridge.

Cost of Operation.—The cost of operation for each opening and closing of vertical lifts is about the same as that for bascules and somewhat less than that for swing bridges. This cost per operation will probably vary from \$1 to \$3 depending on size of bridge, amount of water traffic, cost of power, and other conditions.

Length of Span.—It is generally conceded that vertical lift bridges of long span lengths may be more economically constructed than either bascule or swing bridges.

Interference with Channel during Operation.—Vertical lift and bascule bridges interfere less with the channel than swing bridges, as the swing bridge requires room for its swing, a large central pier, and a draw rest.

Piers.—The vertical lift and bascule bridges do not require a large pivot pier near the center of the channel as in the case of the swing bridge. A large central pivot pier may cause a deflection of the current toward the sides of the channel so as to cause erosion of the banks.

The draw rest required for the swing bridge also obstructs the channel and is a menace to navigation. The maintenance of the draw rest is an

additional expense, and, if this rest is built of timber, the renewal expense is an appreciable item.

Wide Roadways.—A vertical lift bridge may be built as wide as any ordinary bridge without much difficulty, but a swing bridge with a wide roadway requires a large central pier, the construction of which may not be practical because of possible channel obstruction.

Extra Bridges.—When advisable, extra vertical lift bridges or bascules may be constructed very near the first bridge to accommodate increases in traffic. Swing bridges may not be built very close to each other as they require considerable space for swinging. This means that the approaches to the extra swing bridges would have to be curved and that more land would be needed and more filling required than in the case of the extra vertical lift bridges.

Protection to Traffic.—Vehicular and pedestrian traffic over vertical lift bridges may be amply protected during the raising and lowering of the lift span by suitable gates.

Collisions with Boats.—A vertical lift bridge seems to have an advantage over bascule and swing bridges in regard to possible collisions with boats. With the movable span in place, it appears that a boat could do more damage to a swing bridge and draw rest than to either a bascule or vertical lift bridge. Probably less time would be required to repair a vertical lift span than either a bascule or swing bridge. If the movable span was partly open when hit by a boat, the swing span and draw rest of a swing bridge would probably be crumpled up. In the case of a bascule, the bridge would suffer but little if struck by the top hamper of the boat, but considerable damage would result if the hull hit the bascule leaf. A vertical lift span partly raised would probably be high enough to damage the masts, rigging, smokestacks, and pilot house of a boat, and, consequently, no very serious damage would be done to the bridge.

Thus, it appears that the possibility of serious damage due to a collision with a boat would be less with a vertical lift than with a bascule bridge and less with a bascule than with a swing bridge.

Interchangeable Spans.—A bridge of several spans, having one arranged as a vertical lift, may be constructed so as to permit the moving of the towers and lifting machinery from one span to another whenever this is advisable due to a shifting channel. In a bridge of this type all spans are made exactly alike.

Lifting Deck.—The advantage of a lifting deck in a double deck bridge is obvious, as the lifting of the lower deck will permit the passage of the smaller vessels, thus requiring only an occasional lifting of the upper deck for the larger boats.

2. Classification of Vertical Lift Bridges.—The various types of vertical lift bridges may be classified as follows:

- I. Those vertical lift bridges having a lifting span with no lifting deck.
 - (A) With two towers each consisting of four columns braced together in both directions.
 - (1) With no overhead spans.
 - (a) When the two front columns of each tower are vertical and the two rear columns are inclined. Sheaves are placed over the vertical columns (see Fig. 4).
 - (b) When all four columns of each tower are vertical and sheaves are placed over all vertical columns. This type has twice as many sheaves as the preceding class (see Fig. 11).
 - (2) With overhead spans between the tops of the towers.
 - (a) Where the two front columns of each tower are vertical and the two rear columns are inclined (see Fig. 2).
 - (b) Where all four columns of each tower are vertical. (Practically no bridges of this type have been built.)
 - (B) With two towers, each consisting of two vertical columns with cross bracing in one direction, with overhead trusses between the tops of the columns. This type is more suitable for short than for long spans (see Fig. 13).
- II. Those vertical lift bridges having a lifting deck with a fixed or a lifting overhead span.
 - (A) With a lifting deck raising to a fixed overhead span (see Fig. 5).
 - (B) With a lifting deck raising to an overhead span which can be raised to the tops of the towers (see Fig. 8).
- III. Vertical lift bridges of the bascule type. This class includes the Strauss and Rall vertical lift bridges of the bascule type. In general these bridges operate like the bascules patented by Mr. Strauss and Mr. Rall except that the lifting is done at both ends of the span (see Figs. 25 and 26, p. 26).

A further refinement of this classification might be made by considering the location of the operator's house, kind of power used, type of trusses, etc.

3. Adaptability of the Different Types of Vertical Lift Bridges.—Most of the vertical lift bridges of any size that have been built have had a lifting span with no lifting deck, and have had two towers of four columns each. Towers with the rear columns inclined are preferable to those with all vertical columns except in special instances such as skew lift bridges, etc. Inclined rear columns give a much more pleasing appearance to a bridge than do the vertical rear columns. With four-column towers, overhead trusses between the tops of the towers are rarely needed unless pipes or heavy wires and cables are to be carried across the bridge. Vertical lift bridges of the above types have been built with lift spans up to 425 ft. in length and with lifts up to 140 ft. and weights to over 3,000,000 lb.

Vertical lift bridges with two-column towers and overhead spans are more adaptable for short lift spans and lifts of moderate heights.

There have been very few vertical lift bridges built with lifting decks. This type of bridge is often advisable when there are two decks required for the traffic, one (usually the upper) for highway traffic and the other

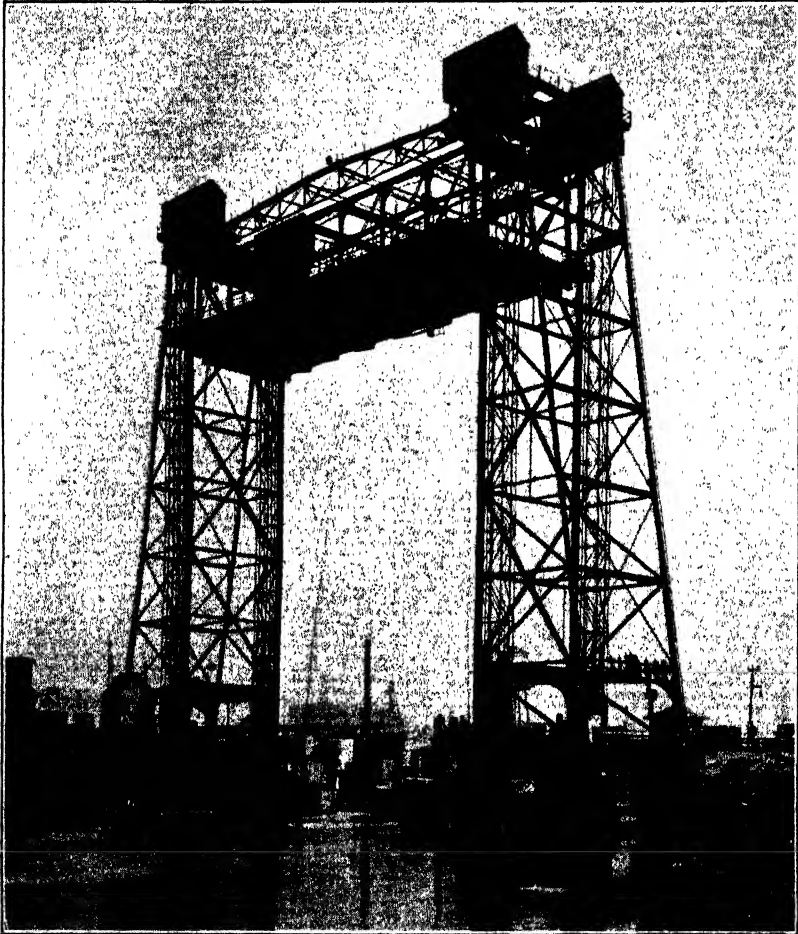

FIG. 1.—South Halstead Street Bridge, Chicago, Ill.

for railroad trains. Thus, when there is a fixed overhead span, only part of the land traffic is inconvenienced by the passage of the boats through the bridge. In the case of a lifting deck and a lifting span, the lifting span has to be raised only for the passage of the larger vessels and thus the land traffic on the upper deck is comparatively rarely interrupted.

Vertical lift bridges of the bascule type are usually more expensive than those just discussed though they have the advantages of requiring no cables and sheaves and they may be readily applied to existing bridges with immovable spans whenever it is found advisable to change one of these spans into a lift bridge.

4. Description of a Few Vertical Lift Bridges.—Following are some brief descriptions of a few of the vertical lift bridges of different types which have been constructed. Except as noted, all of these bridges were designed by the Waddell Company.

South Halstead Street Bridge,¹ Chicago (Figs. 1 and 2).—This was the first vertical lift bridge of any size and importance to be constructed in this country. The span was 130 ft., with a vertical lift of 140 ft. The bridge had a clearance of 15 ft. in its lowered position. The weight of the lifted load was about 600,000 lb. Each tower was 217 ft. high and had four 12-ft. sheaves at the top turning on 12-in. axles. The counterweights were composed of cast iron blocks and were held by thirty-two 1½-in. steel cables, eight of which were fastened at each corner of the truss. The original counterweight cables were in use 28 years and were replaced in 1922 at a cost of \$22,500. Wrought iron chains were used to counterbalance the cables. There were eight up-haul and eight down-haul operating cables ⅞ in. in diameter. These cables were changed three times during the life of the bridge. Pneumatic cylinders were used to stop the bridge in both the open and closed positions so as to check any sudden jar. Movable cast iron weights were used to take care of the wet and dry conditions of the bridge. The original power plant consisted of two 70-h.p. steam engines which were replaced by electric motors in 1907. There was also an operating device that was worked by hand power whenever necessary.

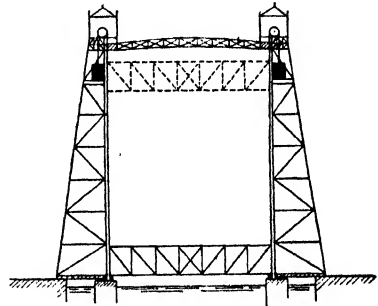

FIG. 2.—South Halstead Street lift bridge, Chicago, Ill.

The Hawthorne Avenue Lift Bridge over the Willamette River at Portland, Ore. (Figs. 3 and 4).—This was the third important lift bridge to be constructed. The foundations for each of the piers for the lift span consist of two concrete cylinders 11 ft. in diameter tapered to 14 ft. with a reinforced concrete diaphragm, and cantilevers for the tower reinforcement. The piers are supported by concrete-filled timber caissons which rest on timber piling. The lift span is a through riveted camelback truss span with an operator and machinery house. This span has a length of 244 ft. 3½ in. and carries a 20-ft. central roadway, two 10-ft. outside roadways with 7-ft. sidewalks, and two street car tracks which are located on the outside roadways.

¹ Replaced by bascule in 1932.

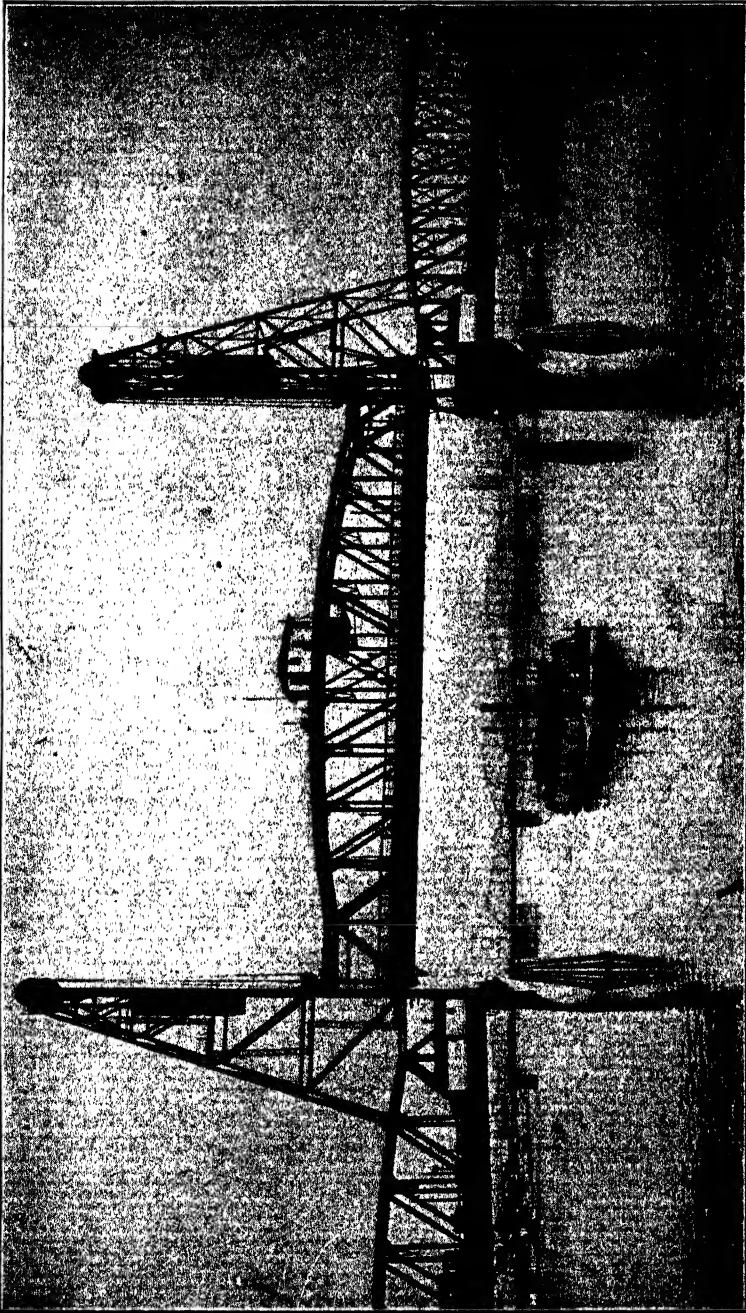

FIG. 3.—Hawthorne Avenue lift bridge over the Willamette River at Portland, Oregon.

The weight to be lifted is about 1,800,000 lb. The lift machinery is quite compact and is located on the central part of the lift span. The power for operation is supplied by two electric motors. The fourteen

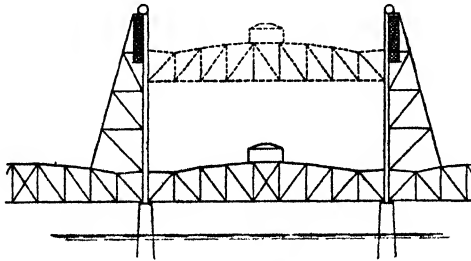

FIG. 4.—Hawthorne Avenue bridge over the Willamette River at Portland, Oregon.

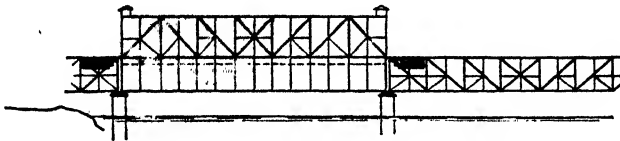

FIG. 5.—Fratt Bridge over the Missouri River at Kansas City, Mo.

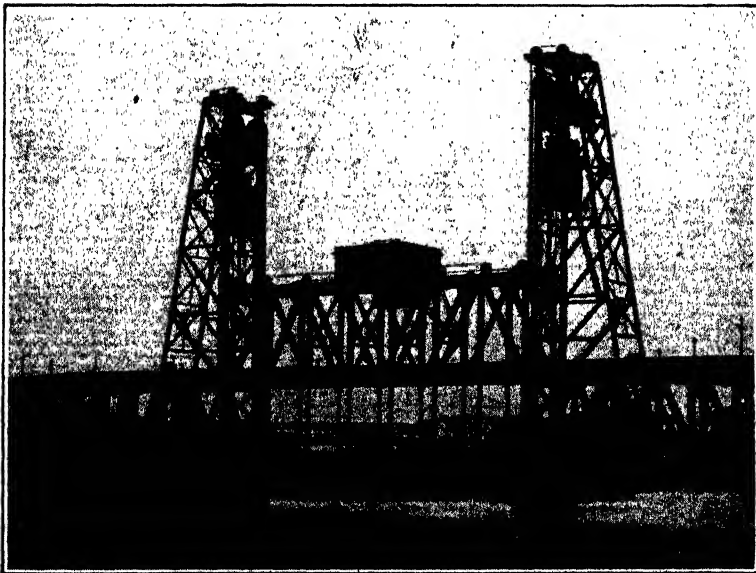

FIG. 6.—O-W. R. R. & N. Co.'s lift bridge over the Willamette River at Portland, Oregon.

lifting cables are $\frac{3}{4}$ -in. wire cables which pass over 8-ft. cast steel sheaves with $12\frac{1}{2}$ -in. axles. The counterweights are of concrete. This bridge was erected in 1911 at a cost of \$511,216.

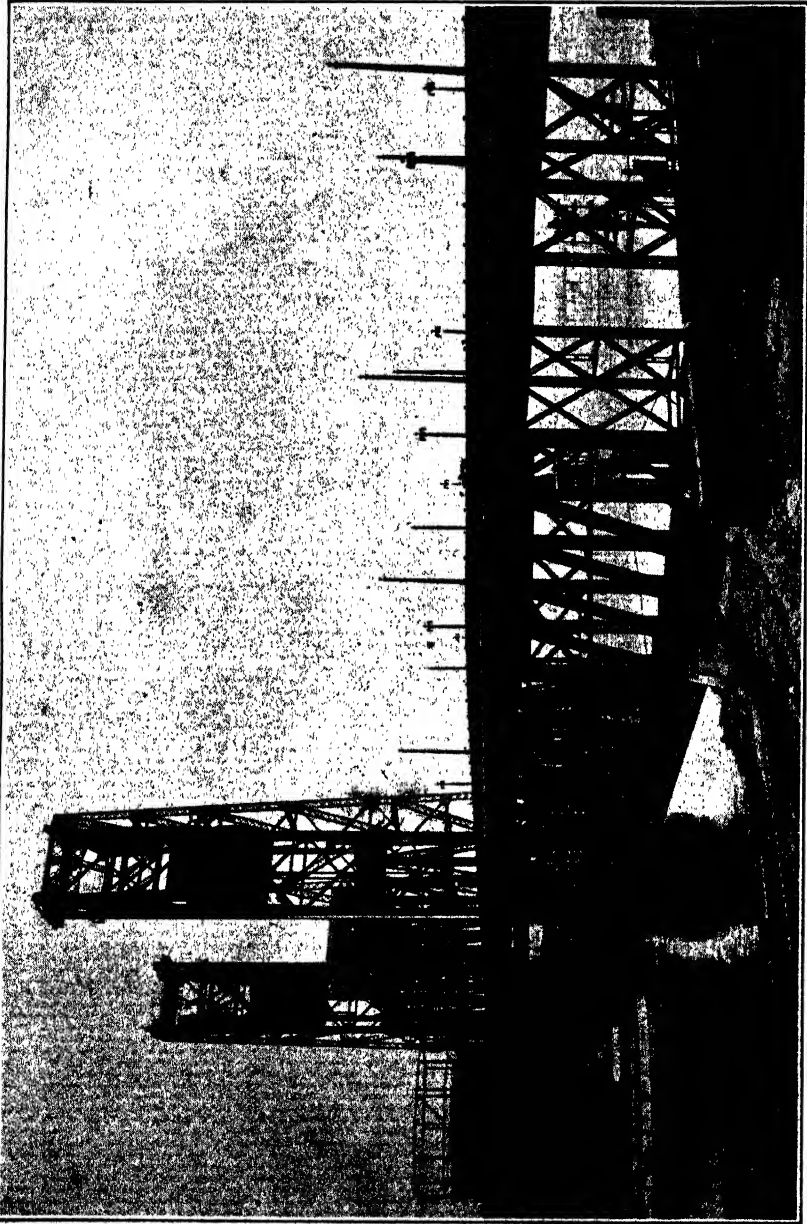

Fig. 7.—O. W. R. R. & N. Co.'s lift bridge over the Willamette River at Portland, Oregon (lower deck raised).

The Fratt Bridge over the Missouri River at Kansas City, Mo. (Fig. 5) has a lifting deck which raises into a fixed overhead span. This bridge is the only large lift bridge of this particular type in the country. There are two decks on this bridge, the upper deck carrying two street car tracks, roadways and sidewalks, and the lower deck two railroad tracks. Only the lower deck is raised. The length of the lift span is 425 ft., the weight to be lifted is 1,560,000 lb., and the height to be raised is 43 ft., giving a clearance of 55 ft. above high water. The lifting deck and vertical hangers are constructed of nickel steel to reduce weight. When the deck is raised, the vertical hangers telescope into the truss posts above. The raising is accomplished by means of cables, two of which are attached to

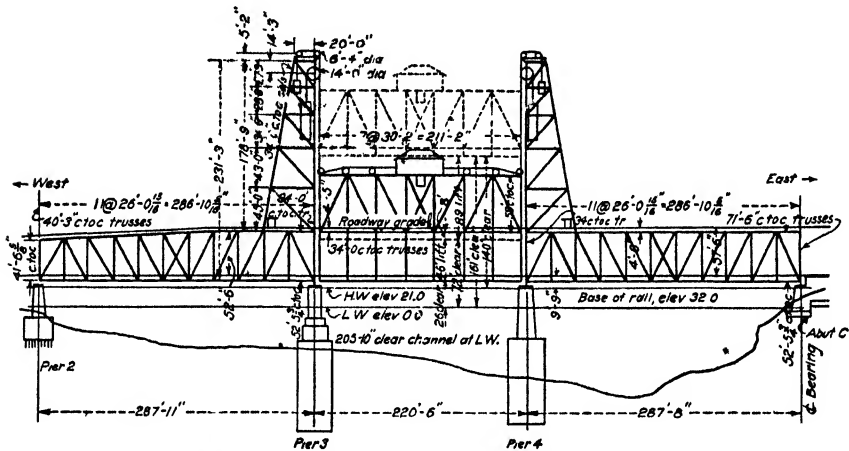

FIG. 8.—O-W. R. R. & N. Co.'s lift bridge over the Willamette River at Portland, Oregon.

each hanger. These cables pass from the hangers over sheaves in the top of the truss and then over a drum and down to a counterweight. Each hanger has a separate counterweight. Operating power is supplied by two sets of electrical machinery, either motor being large enough to operate the bridge. When the deck is in its lower position, it is automatically locked and the stress is transmitted directly to the truss posts above by means of pins in the end of each hanger.

Oregon-Washington Railroad and Navigation Company's Bridge Over the Willamette River at Portland, Ore. (Figs. 6, 7 and 8).—This bridge is of especial interest because of a lifting lower deck and a lifting span. The lower deck, which carries railway traffic, can be raised to the lifting span to permit the passage of tugs, lighters, and small vessels, while the lifting span (with the raised lifting deck) can be raised to permit the passage of ocean going ships. The bridge was completed in 1912 at a cost of about \$1,700,000.

The lift span of the bridge is 211 ft. long, and the lift of the lower deck alone is 46 ft. while the lift of the upper deck is 89 ft. giving ample clearance for the largest ocean going ships. The lower deck has a clearance of 26 ft. above low water and 5 ft. above high water. The lower deck has its own set of counterweights, and it weighs, with its attachments, about 1,060,000 lb. The upper deck weighs about 3,420,000 lb., exclusive of counterweights. Thus the total moving load is about 9,000,000 lb., including counterweights, making this lift bridge one of the heaviest yet built.

The upper deck is suspended by $2\frac{1}{4}$ -in. cables at each corner. These cables pass over the main sheaves (14 ft. diameter and 24 tons weight) fastened near the top of towers about 245 ft. above the top of the piers. This deck is raised and lowered by up haul and down haul cables. The lower deck has four $1\frac{1}{4}$ -in. counterweight cables for each panel point. This deck is moved by traction sheaves at the corners of the lift span.

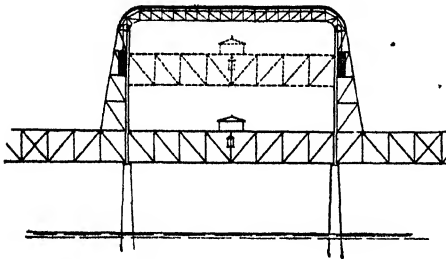

FIG. 9.—City Waterway Bridge at Tacoma, Washington.

About 20,000 openings a year are made with the lower deck and only about 1,000 openings with the upper deck.

There are four 200-h.p. motors used for operating this bridge, two for the lower deck and two for the upper deck. These motors are placed with the other operating machinery in a house constructed at the center of the top of the upper lift deck. The operator's house is placed just below the machinery house so that the operator can have a full view of the highway traffic on the upper deck as well as the water traffic. The automatic locking apparatus for both lifting decks is placed in the operator's house.

City Waterway Bridge at Tacoma, Wash. (Fig. 9).—This lift bridge has two unusual features, the height of the bridge floor above the water and the overhead span between the tops of the towers for carrying a water main. The 214-ft. lift span has two flanking trusses, each 190 ft. long, and 650 ft. of steel trestle. The height to be lifted is 78 ft. and the lifted weight is 1,640,000 lb. The bridge was constructed for highway traffic and has a 50-ft. roadway paved with wood block, and two 10-ft. walks. The bridge was completed in 1913 at a cost of \$480,000.

Pennsylvania Railroad Bridge 458 over the South Branch of the Chicago River (Figs. 10 and 11).—This Waddell and Harrington double track railway lift bridge is built on a skew and has a span of 273 ft. and a vertical lift of 114 ft. Each tower is composed of four vertical columns with sheaves of 15-ft. pitch diameter over each column. The counterweight cables are sixteen $2\frac{1}{4}$ -in. plow steel ropes connected to the top chords at each end of

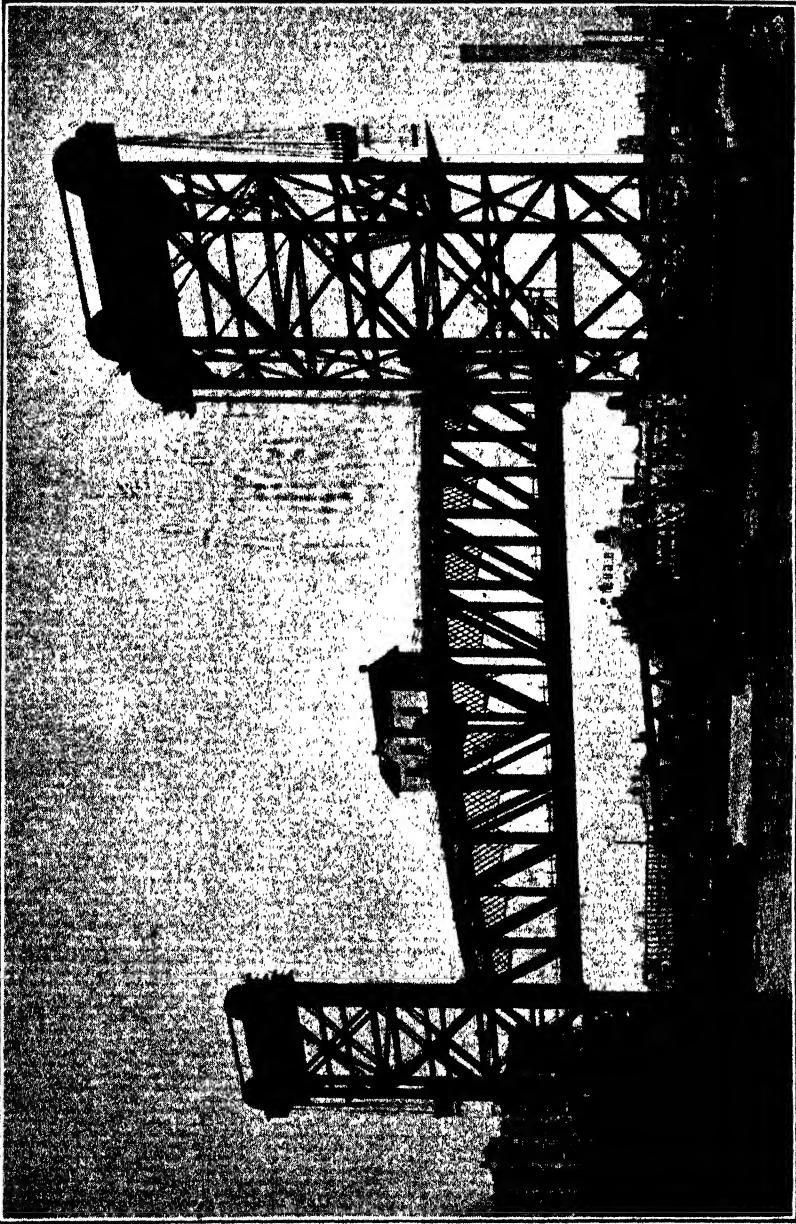

Fig. 10.—Pennsylvania R. R. Co.'s lift bridge No. 458 over the Chicago River, Chicago, Ill.

each truss and by equalizing devices to the counterweights. The operating cables consist of two 1½-in. up haul and two 1½-in. down haul cables at each end of each truss.

The weight of the lift span, being a little more than 3,000,000 lb., makes this bridge one of the heaviest lift bridges constructed.

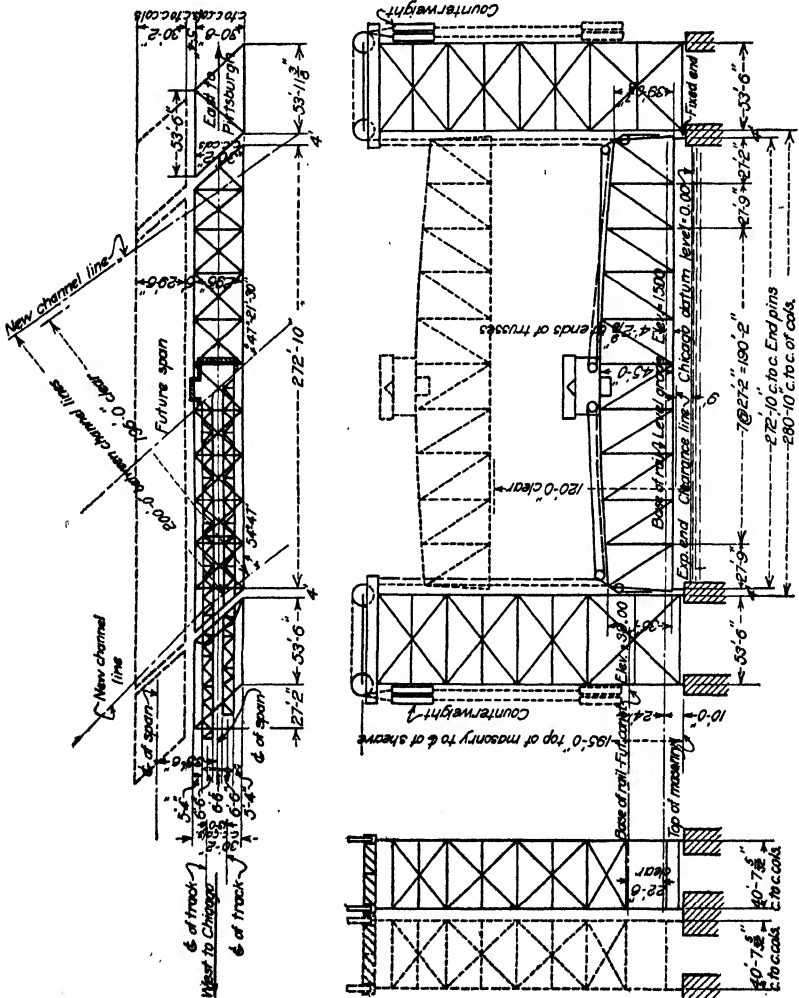

Fig. 11.—Pennsylvania R. Co.'s lift bridge No. 458 over the Chicago River, Chicago, Ill.

The power plant consists of two motors geared to four cast steel operating drums, and will lift the span to its maximum height from its normal position in 45 sec. Either motor alone is powerful enough to operate the lifting machinery. A 50-h.p. gasoline engine has been installed for emergency service. It requires about 10 min. for this engine

to raise the lift span. Both solenoid and hand brakes are provided. All operating levers and switches are placed in the operator's house as well as a mechanical indicator showing the position of the lift span.

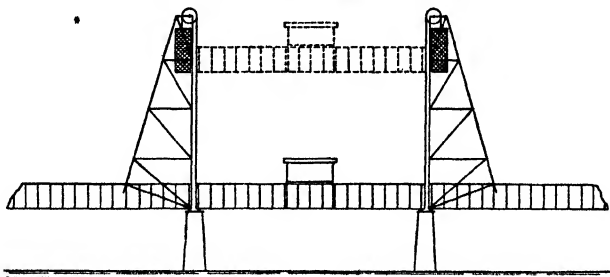

FIG. 12.—Canadian Northern Pacific Railroad Company's bridge over the North Thompson River in British Columbia.

The bridge was designed for a track elevation of 24 ft. in the future. A vertical lift railway bridge of one span is more easily adapted to future changes in track levels than is any other type of movable bridge.

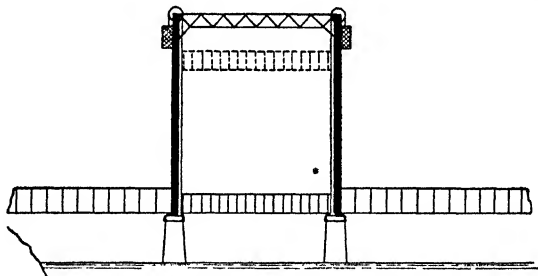

FIG. 13.—St. John & Quebec Railroad Company's bridge over the Oromocto River in New Brunswick, Canada.

The Canadian Northern Pacific Railway Bridge over the North Thompson River in British Columbia (Fig. 12).—This railway plate girder lift bridge is unique in that the lift towers can be moved so as to raise any

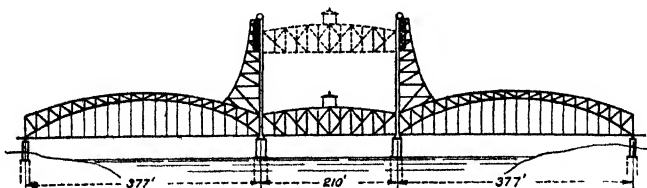

FIG. 14.—Vladicaucase Railroad Company's bridge over the Don River near Rostoff, Russia.

one of the spans which are all made exactly alike. The reason for this construction is to take care of a possible shifting of the channel of the river. The lift span has a length of 90 ft., a weight of 236,000 lb., and a vertical rise of 56 ft.

St. John and Quebec Railway Bridge over the Oromocto River in New Brunswick, Can. (Fig. 13).—This type of vertical lift bridge is different from the ones previously described in that each tower is composed of only two columns. There are two light trusses between the tops of the towers. The length of the lift span is 58 ft., the weight 147,000 lb., and the vertical lift 59 ft. Hand power is used for this bridge.

Don River Bridge at Rostoff, Russia (Fig. 14).—This lift bridge is quite different from the vertical lift bridges of this country, especially in the treatment of the flanking spans and the curved rear columns of the lift towers. The lift span, towers, and machinery were designed by Doctor Waddell while the adjacent spans were designed by Russian government engineers. The lift span has a length of 210 ft., a weight of 1,600,000 lb., and a vertical rise of 131 ft.

5. General Design Notes.—The following notes are on the *general* design of vertical lift bridges and include information on the particulars in which vertical lift bridges differ from ordinary bridges with fixed spans. If more detailed information is desired, the treatise on "Bridge Engineering" by Doctor Waddell and the various articles in the technical press should be consulted.

The Truss of the Lift Span.—In general the lift span truss is designed in the same way as the ordinary fixed span truss with the exception that suitable seating devices must be provided at the ends of the lift span and means devised for the fastening of the various cables attached to the span. Provision must also be made for the placing of the necessary machinery, machinery house, and operator's house on the lift span.

Towers.—For long spans and high lifts, each tower should be composed of two vertical front and two inclined rear columns well braced in both directions. Provision must be made for fastening the sheaves on the vertical columns by suitable sub posts or by a sheave girder. In this type of tower the counterweights move up and down inside the tower.

For short spans and low lifts, where the lift span is usually a plate girder, the towers should each be constructed of two vertical columns with sway bracing between them. The tops of the columns of the two towers should be connected by light trusses to assist in keeping the towers vertical and to hold them the correct distance apart. Sheaves are placed on top of the columns and the counterweights move up and down outside of the columns.

When the lift span is built on a skew and the towers are supported independently on masonry foundations, it is desirable to construct each tower of four vertical posts well braced in both directions. Horizontal bracing should be provided near the tops of the towers. The sheaves should be placed on all four columns of each tower and the counterweights at the rear of the towers.

Towers should be cambered so that they will be vertical under dead load only (there should be no live load on the lift span when it is raised and lowered). No camber is necessary for towers having two or four vertical columns resting on masonry and having a sheave on the top of each column. When the tower is composed of two vertical and two inclined columns, with the vertical front columns resting on a pier and the inclined rear columns resting on a supporting truss, the tower should be cambered so that the vertical columns are really vertical when the lift span is being raised and lowered. In this type of tower the sheaves are usually placed directly over the vertical columns, hence these columns carry practically all of the load.

Guides and Centering Blocks.—Guides should be attached at the eight corners of the lift span so as to keep it in line while being raised and lowered. Roller guides that fit with sufficient clearances in vertical tracks on the tower are the preferable type. The guides should be designed for wind loads on the span and also for train thrust (in case of a railway bridge) and any other loads that may be applied to them.

Centering blocks should be attached to the four lower corners of the lift span to hold this span in place when it is in its lowered position. These blocks should engage blocks attached to the base of the towers. Some longitudinal movement must be provided for at one end of the span.

Counterweights.—Counterweights for vertical lift bridges should be made of concrete cast on a steel framework. This framework should be strong enough to carry the concrete when attached to the lifting cables. Cast iron blocks may be used when sufficient space for the concrete is not available.

Counterweights should weigh about 5 per cent less than the weights to be balanced. Movable weights equaling in all to about 10 per cent of the balanced weights should be provided so that the proper balance may be obtained between the lifted weights and the counterweights. These movable weights should not weigh more than 200 lb. each and they should be provided with eye- or U-bolts for handling. Safe places should be provided for these movable weights in the top of the counterweight framework. The space provided must be such that none of the movable weights will project above the top of the counterweight framework.

The inside face of the counterweight should be provided with guides which engage tracks on the tower. Ample clearances should be provided so that the counterweight will not bind or stick. Clearances of 2 in. or more should be provided between the tower steelwork and counterweights. If a counterweight is composed of two or more parts, about 2-in. clearance should be allowed for between the parts. When the counterweight is in its lowest position, it should be not less than 3 ft. above the bridge floor.

Counterweight Cables and Balancing Chains.—The counterweight cables for vertical lift spans should preferably be of plow steel and consist of six strands of 19 wires each, constructed around a hemp center. The sockets may be open or closed, but should be of standard design.

When the span is being raised, the lifting and counterweight cables will cause an unbalanced condition between the span and the counterweights. This condition may be met by adding extra motive power or by adding balancing chains. If balancing chains are used, suitable buckets must be provided for catching the chains as the span lifts.

Equalizers.—Equalizers of suitable design should be provided between the counterweights and counterweight cables. The other ends of the counterweight cables should be attached directly to the lift span.

Sheaves.—The pitch diameter of the sheaves should be equal to at least 60 times the diameter of the cable. Clearances of at least $\frac{1}{8}$ in. should be allowed between cables on sheaves, and sheaves should be grooved to fit the cables. Sheaves up to about 14-ft. pitch diameter may be made of cast steel, but larger ones should be built up of structural steel with cast steel rims and hubs. Each sheave should be fastened to its shaft by at least three keys. Sheaves at the top of the towers should be protected from the weather by hoods or housings, especially in climates where there is snow and sleet. The sheave shafts should be designed for bending, bearing, and shear stresses. The bearings should be large, properly aligned, well oiled, and not placed too far apart.

Buffers.—Buffers, either of the hydraulic or air types, should be provided for assisting in the stopping of vertical lift spans. Suitable buffers permit of the stopping of the span without any jar.

Locking Apparatus.—A suitable locking device should be used for the lift span to securely lock it in position before traffic is admitted to the span. The locking device must be arranged so that it can be applied or released by the operator when he is at his station. Rail locks should be used for railway and street car tracks.

Gates.—Strong and substantial gates must be provided to protect the highway traffic while the lift span is raised. These gates should be in position before the lift span is raised and remain in position until the lift span is lowered and locked in place. For satisfactory operation, four gates are usually needed. The gates should be closed and opened either by the bridge operator or by special gate tenders. When gate tenders are used, small neat houses should be provided for them near each end of the lift span. Just before the gates are closed, a warning signal should be given for the benefit of the traffic.

Cantilever Walks and Roadways.—When wide sidewalks are cantilevered outside of the trusses of the lift span, the possible effects of live loads on one walk only must be carefully considered, especially in regard

to unbalanced loading and overturning moment. Proper end bearings must be provided when necessary. When a roadway or a street car track is cantilevered outside of the main trusses, provision must be made for the overturning moment caused.

Machinery House.—The machinery for a vertical lift span is usually placed in a machinery house on top of the center of the lift span. This house should be well built with ample space for the machinery, work bench, and stove. In very large and heavy bridges, the placing of a 5-ton crane in the machinery house is advisable. Suitable stairs and walks should be provided to gain access to the machinery house and the machinery.

In deck girder spans, the machinery may be placed below the bridge floor and between the girders, while in a half through plate girder span the machinery may be placed below the bridge floor or outside of the girders.

Operator's House.—When the operator does not stay in the machinery house, he should have a small house provided for him in a place where he can have an unobstructed view in all directions of the water and bridge traffic. The operator's house must be large enough for the operator, operating machinery, and heater, and it should have a large amount of window space. A good stairway should be provided.

Bridge Gage.—At one of the towers and on both the upstream and downstream sides, gages or indicators with large figures should be provided for the convenience of the boats showing the height of the water and also the height that the lift span is raised.

Operating Machinery in General.—In general the operating machinery should be compactly arranged and have no more reductions than necessary. When four drums are used, one reduction should be placed at the drums. The machinery should be arranged so as to permit of easy access for oiling, inspection, repairs, and replacement.

Power Required for Vertical Lift Spans.—In general the power required for raising and lowering vertical lift spans is approximately 1 h.p. for every 15 or 20 tons of moving load. This load includes the weight of lift span, counterweights, and all moving parts. While improvements in the design and arrangement of the machinery may lessen the power required for an operation under average or good conditions, yet there must be a reserve of power available for times when operating conditions are not so good. Wind, snow, and sleet all tend to increase the power required.

The power required for a vertical lift span may be computed from the known data of the span. In general, the power must be sufficient to accelerate the span and overcome the following resistances: Friction between guides and tracks; friction in gears, drums, and sheaves; the bending of cables off and on sheaves and drums; inertia of moving parts.

of machinery; extra loads caused by winds; extra loads caused by snow and sleet; and the other unbalanced loads on the lift span.

The force required for accelerating the lift span may be computed from the equation $F_1 = \frac{Wa}{32.2}$ where F_1 = force required in pounds, W = total weight of all moving loads in pounds, a = acceleration in feet per second per second, and 32.2 is the acceleration of gravity. The time required for raising or lowering a lift span usually varies from 30 to 90 sec., and the time that the span is accelerated usually varies from 10 to 20 sec. The time for retardation usually requires from 10 to 15 sec. Then, the raising or lowering of the span would be divided into three periods: A period of acceleration; a period of uniform or constant speed of travel; and a period of retardation. Assuming that the average speed during the periods of acceleration and retardation is half that during the period of uniform speed of travel, the uniform speed of travel can be easily computed. Then the average acceleration in feet per second can be computed and the force F_1 determined.

Friction between girders and tracks should be taken as about 15 per cent of the normal wind load. For ordinary operations, a normal wind load of 2 lb. per sq. ft. on the vertical projection may be assumed, though the span should be able to operate (but more slowly) under a wind load of 25 lb. per sq. ft.

The efficiencies of different kinds of gears vary considerably, and the following values are only approximate. Adverse conditions will reduce these efficiencies greatly.

EFFICIENCY OF GEARS (one pair)

Spur gears (well designed)	90 to 95 per cent
Bevel gears (well designed)	75 to 90 per cent
Worm gearing	50 to 65 per cent

The force required to bend the cables on and off of the sheaves and drums will vary considerably, say from 5 to 15 per cent according to conditions.

Journal friction at the surface of the shaft may vary from 4 to 15 per cent of the applied load. This force must be reduced to an equivalent force at rim of sheave or surface of drum. Usually journal friction, as such, is included in the gear efficiencies and the sheave and drum resistances so that separate computations for this are not required.

The force required to overcome all unbalanced loads should also be included. The counterweight cables are always unbalanced (except when the span is raised half way) unless balancing chains are provided. Snow causes an unbalanced load if extra weights are not added to the counterweights to counteract it. The unbalanced load should be much less than 5 per cent of the weight of the lift span.

Power Equipment.—The power equipment required depends on the size and weight of the lift span. Unless the span is very light and the lift comparatively low, mechanical power equipment is advisable. But whatever the kind of mechanical power selected, some method of hand power must also be installed so that the lift span can be operated (though slowly) in event of emergencies.

In the selection of mechanical power, the electric motor is given the first place, the internal combustion motor second, and steam power third. The electric motor is especially suitable for lift bridge operation as it provides a large starting torque and is capable of carrying a 100 per cent overload on occasion. When two or more electric motors are used, it is customary to select them of such a capacity that half of them have power to operate the bridge in case the other half are out of commission. Storage batteries are sometimes rather unsatisfactory and expensive, hence their use should be avoided.

Internal combustion motors are satisfactory if they are of a capacity to carry at least 125 per cent of the load. This type of motor usually will not carry much, if any, overload. For large bridges, where hand operation for emergencies is not practical, the internal combustion motor is a good alternate for the electric motor.

Steam power is satisfactory as far as handling the load is concerned, but is very expensive to maintain in ready operating condition as the steam pressure must be kept up at all times. This type of power requires a boiler and steam engine and needs more attendants to operate it than in the case of electric or internal combustion motors. For a lift bridge that is operated only a comparatively few times, the steam power is very expensive. There is a further objection to the coal smoke from the fires.

For hand power equipment it may be assumed that a man will exert a force of 35 to 40 lb. on a lever with a speed of 150 to 160 ft. per min., thus giving from $\frac{1}{6}$ to $\frac{1}{3}$ h.p. For *starting* the machinery a man can exert a force of about 100 lb. A suitable platform, windlass and levers must be provided for hand operation on large bridges, while a small windlass and cranks are satisfactory for small, light lift spans.

Efficient, easily operated hand brakes of simple design should be provided so that the bridge can be readily stopped and held in any position within 10 or 15 sec. after the power is shut off. Brakes of the band type are generally satisfactory. Electric brakes of the solenoid type are suitable for the electric motors, and these should be installed in addition to the hand brakes. It is preferable to have two sets of brakes in most instances.

Machinery Equipment.—In general, all of the machinery equipment should be simple in design; solid in construction; easy to inspect, oil, clean, and adjust; and easy to remove for repairs and renewals. Shafts,

bearings, etc., should keep in their proper position and alignment after being installed. Bearings should be designed and constructed so that they may be tightened occasionally to take up wear.

Operating Cables.—The cables used to raise and lower the lift span should be of plow steel and be composed of six strands of 19 wires each constructed on a hemp center. These cables should never be less than $\frac{3}{4}$ in. in diameter. Preferably two cables for raising and two cables for lowering should be used at each corner of the lift span, unless the force required to move the span is so small that only one cable is required. These cables should be securely attached to drums in the machinery house at the center of the span and should pass from the drums over deflecting sheaves at the ends of the span and thence to the top and bottom of the towers. Some method must be provided for taking up the slack in the cables.

Whenever it is necessary to support the cables between the drums and deflecting sheaves, good rollers of not less than 6 in. in diameter should be used so that they will easily revolve and keep the cables from wearing.

Operating Drums.—For small lift spans two drums are required at the center of the span, one for the cables on each side. For larger spans, four drums are advisable. All drums should be grooved so that they may receive the cables from both ends of the span. The diameter of the drums should be about 40 times that of the operating cables, and they should be grooved so that there will be at least $\frac{1}{16}$ in. clearance between the cables wound on the drum. The number of grooves on each drum should be such that there will never be less than one and one-half or two complete turns of any cable left on the drum.

Deflection Sheaves.—The deflection sheaves for the operating cables should be of the same diameter as the drums and properly grooved for the cables. If there are two cables, the clearance between cables should be at least $\frac{1}{4}$ in. A small idler sheave should be placed below each deflection sheave and toward the center of the span to prevent the up haul cable from leaving the deflection sheave when it is a little slack.

Gears.—All gears should have involute machine cut teeth and the face width of the gear should be about two and one-half times the circular pitch. The use of bevel gears should be avoided. Worm gears may be used, provided that the gear shall have 30 or more teeth and that both worm and gear are made to run in oil. Worm gears are less efficient than spur gears.

Pinions.—Pinions should not have less than 17 teeth and the ratio of reduction of the gear to the pinion should not be less than four.

Bearings and Bushings.—Single bearing frames should be used for all shafts in a unit wherever possible. Bearings should be placed close to the points of loading to eliminate bending in the shafts, and they

should permit any gear to be removed without moving other gears. All bearings should be of the split type and provided with necessary shims. Four bolts should be used to bolt caps to bases except in the case of small bearings where two bolts are sufficient.

Bronze bushings one-twelfth of the thickness of the shaft should be properly grooved so that the shafts may be lubricated by screw feed grease cups.

6. Recent Vertical Lift Spans.—Although in general the principles of design outlined in the previous articles are applicable to lift spans recently constructed, several new ones employ a method of operation which is quite different from that used prior to 1935. By the use of synchronous motors coupled to the same shaft as the drive motors it is possible to place the operating machinery on housed-in decks at or near the tower tops. This arrangement also permits applying the power through suitable gear trains to the counterweight sheaves, thus eliminating the operating cables common to earlier designs.

Buzzard's Bay Bridge over Cape Cod Canal, Massachusetts (Fig. 15).—This bridge, constructed in 1935, has several unusual features besides the synchronous tower drives. It has the longest lift span of any bridge

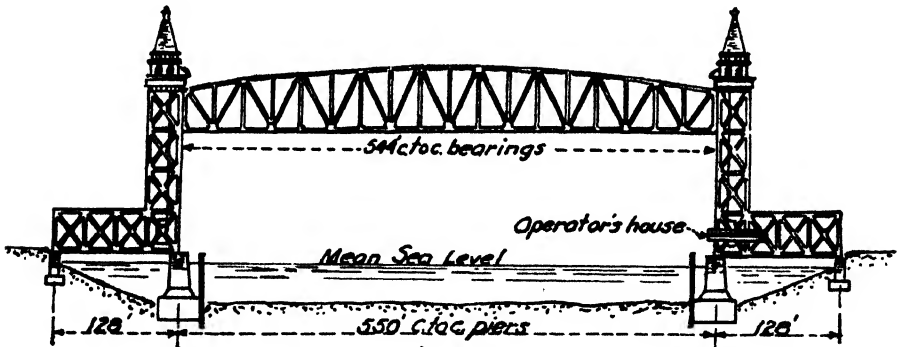

FIG. 15.—Buzzard's Bay Bridge over Cape Cod Canal, Massachusetts. (Courtesy of *Engineering-News-Record.*)

constructed, 544 ft. c. to c. of end bearings. In the open position it provides a clearance of 139 ft. above mean sea level and a clear width of 500 ft. between fenders. It carries a single track railroad over the canal. As the daily railroad movements are few and there is considerable navigation on the canal, the towers were so designed that the lift span is maintained in the open position except for train movements. Each tower has four vertical columns, braced in both directions and framed into the flanking spans. There is a housed-in deck at each tower top, that supports the machinery and counterweight sheaves. On each deck there are four 15-ft. counterweight sheaves geared directly through suitable gear trains to the operating motors (Fig. 16). Each sheave carries ten

2½-in. steel wire ropes. Sufficient friction is developed between these ropes and the sheaves to provide the coupling medium which permits the operation of the lift span, without the use of operating cables common to previous designs.

Each operating unit is driven by two 150-hp. motors connected to the same shaft. One of these motors is synchronous and both of the synchronous motors are tied in to each other electrically so that the

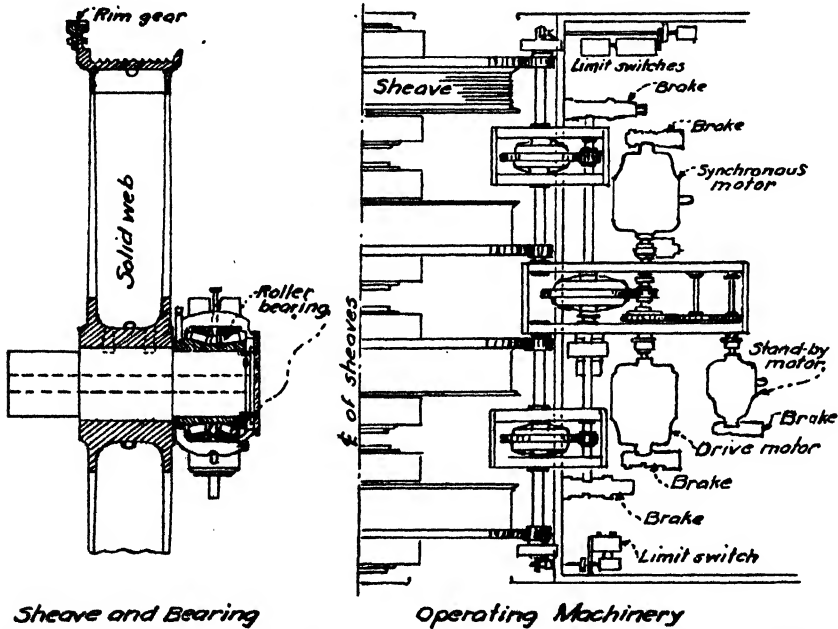

Fig. 16.—Driving machinery, Buzzard's Bay Bridge. (Courtesy of Engineering-News-Record.)

operating units are kept in step; thus, the lift span is maintained in a level position when being raised or lowered. In the event that the span should get out of level, manually operated controls are provided so that it may be brought to its proper position. Automatic devices which shut off the power whenever the span gets out of level by 2 ft. are also provided. Each operating unit is also furnished with a stand-by motor which is connected to a gasoline-driven generator. This arrangement permits the operation of the bridge whenever the main source of power is disrupted. The shaft on which the counterweight sheaves are mounted is supported by roller bearings of unusual size and capacity. Because of the free running character of this type of bearing, the operating machinery is equipped with an extensive braking system.

Although this type of drive costs substantially more than those formerly used, it is estimated that it requires approximately 50 per cent less power. Whenever there is a considerable stand-by charge for electrical power, which is usually the case, the use of this type of drive is sound practice. It is compact and lends itself readily to architectural treatment.

Triborough Bridge over Harlem River, New York (Fig. 17).—This bridge, constructed in 1936, contains a good example of a highway lift span of recent design. This span is 310 ft. long and the distance between the main trusses is 75.5 ft. It carries two 30-ft. roadways separated by

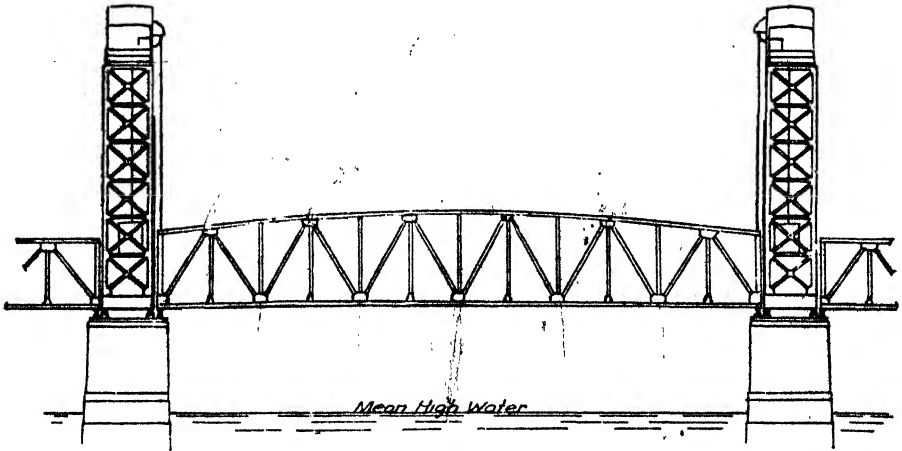

FIG. 17.—Triborough Bridge over Harlem River, New York. (Courtesy of *Engineering-News-Record*.)

an island and also an 8.5-ft. sidewalk on the outside of each truss. The weight of the completed span is 2,050 tons. In the closed position the lift span provides a vertical clearance for navigation of 55 ft. and in the open position 135 ft.

Synchronous tower drives similar to those of the Buzzard's Bay Bridge are used to raise and lower the lift span. Each tower has two legs made up of four vertical columns braced both ways. The legs of a tower are connected at the top by trusses on the top chords of which is placed the machinery deck. On each deck are located four 15-ft. counterweight sheaves, each carrying twelve $2\frac{1}{4}$ -in. wire ropes. It should be noted that the tower legs rest directly on the masonry piers and are entirely independent of the flanking spans. This arrangement is unusual and was adopted by the designers because of architectural considerations.

Interstate Toll Bridge over Piscataqua River, Portsmouth, N. H. (Fig. 18).—This bridge, opened to traffic in 1940, has two decks, the upper for highway traffic and the lower for a single track railroad. Both decks

of the lift span are raised and lowered simultaneously. This span is 224 ft. long, weighs 900 tons, and in the fully raised position provides a vertical clearance of 125 ft. for navigation. It is raised and lowered by synchronous tower drives similar to those previously described. On each tower there are two 10-ft. counterweight sheaves, each of which carry sixteen $1\frac{3}{4}$ -in. wire ropes.

The towers have two legs each which rest directly on the masonry piers and are also connected to the flanking spans for added stability. The design of these legs is unusual for this type of bridge. Instead



FIG. 18.—Interstate Toll Bridge, Portsmouth, N. H.

of braced columns, an enclosed box section was used. One leg of each tower is equipped with an elevator and the other with a ladder which provide access to the machinery at the tower tops.

The operator's house is located near one of the tower legs at the upper deck level. The operator has full control over all trains approaching the bridge through a set of signals on the railroad. The controls of the operating machinery are inoperative until these signals are set against all trains approaching the bridge. Failure of the railroad signals to work properly is indicated by lights in the operator's house. The operator, however, has a telephone by which he can notify the local railroad signal office whenever this condition occurs, as all railroad signals are maintained by the railroad.

SECTION 3

SWING BRIDGES

CENTER-BEARING SWING BRIDGES

1. General Considerations.—When a bridge of this type is open, each truss is supported at the end of a cross-girder which rests on a center bearing C (Fig. 1). This bearing is usually a phosphor bronze disk, from 1 to 3 ft. in diameter, between two hardened steel disks. To prevent the bridge from tipping, balance wheels W about 18 in. in diameter and six to eight in number, are fastened to the trusses and floor system in such a way that they roll on a circular track t . These wheels are so adjusted that they carry no load, except when the bridge is out of balance on account of wind pressure or similar causes.

When the bridge is closed, the ends a , b , d and e are raised a proper

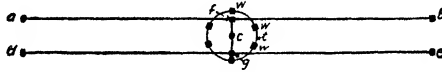

FIG. 1.

amount by wedges. Wedges are also inserted at f and g a sufficient amount to give the trusses a bearing on the pier independent of the cross-girder, but no attempt is made to lift the trusses at these points in order to relieve the cross-girder of any of the dead load. Thus at the center support, the dead load is carried by the cross-girder, while the live load is supported directly by the pier.

2. Conditions of Loading.—When the bridge is open, the dead load is balanced about the center support. When the bridge is closed, the total dead load reaction at the center is relieved, as the wedges are driven and the ends raised. (If the ends were raised to a sufficient height, the bridge would be lifted free of the center support, and the reaction which formerly supported the bridge would be transferred from the center to the ends.) The mechanical parts of the bridge are usually designed in such a way that the end wedges, when fully driven, will provide a positive dead load reaction somewhat greater than the negative live load and impact reaction. This insures the bridge against hammer-

ing of one end when the train comes on at the other end. By this arrangement, the dead load end reactions are less than those obtained theoretically when the truss is considered as a continuous beam over three level supports. The cost of installation and operation is thereby reduced.

If hammering is eliminated and the ends remain fixed in elevation, the live load reactions may be computed on the basis of complete con-

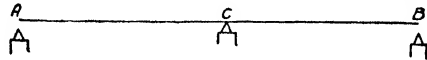

FIG. 2.

tinuity of each truss. If, however, on account of error in design or adjustment of the wedges, or because of settlement of the piers, it happens that no dead load end reaction is present, we have the condition as illustrated in Fig. 2. Let us assume, for example, that a very small clearance exists between the beam and its end supports. The total weight of the beam is supported at C, as is the case when the bridge is open. When the live load comes on the arm BC (Fig. 3), the beam tilts until it finds a bearing at B; and the live load is supported by BC acting

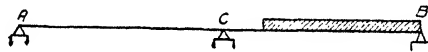

FIG. 3.

as a simple span. However, the dead load or weight of the beam is still entirely supported at C. If the live load is present in both arms (Fig 4), the beam will deflect until it has a bearing at A and B, and thus a condition of continuity, or partial continuity, must be considered in finding the live load reactions. The extent of the continuity will depend upon the amount of clearance which previously existed at A and B in Fig. 2. The dead load is still totally supported at C. In order to provide

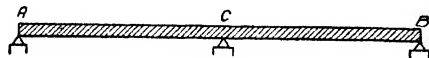

FIG. 4.

for these contingencies, the following conditions or classes of loading should be considered.

Case I.—Dead load—bridge open or wholly supported at the center.

Case II.—Dead load—bridge closed, both ends raised until a definite end reaction is attained (amount to be specified after negative live load and impact end reaction have been determined).

Case III.—Live load on one arm only—simple span action.

Case IV.—Live load on one arm only—continuous girder action.

Case V.—Live load on both arms—continuous girder action.

If the ends are raised, we have Case II, combined with Case IV or Case V. If the ends are not raised, we have Case I, combined with Case III or Case V.

The bottom chords are usually better protected from the rays of the sun than the top chords. Because of this, and also on account of cold weather and ice, it is apparent that the temperature of the top chord may be considerably higher than that of the bottom chord. Thus the top chord may be lengthened and the bottom chord shortened, causing the span to "hump" at the center, thereby relieving the center reactions somewhat and increasing those at the ends.

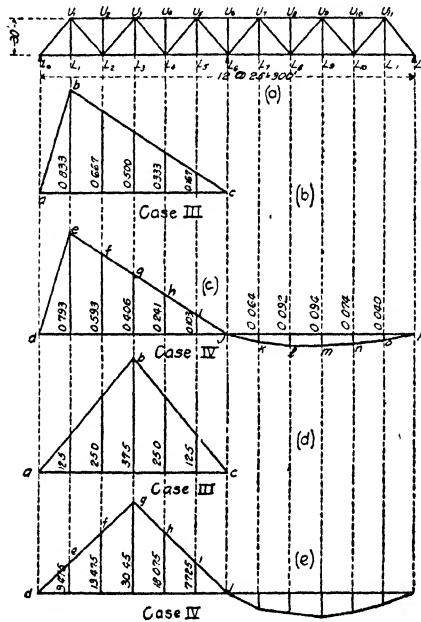

FIG. 5.

Except in special cases the temperature factor is neglected.

3. Stresses in a Swing Span.—The stresses for the five cases of loading will be computed for the 300-ft. span (Fig. 5a). The assumed dead load is 3,000 lb. per ft. of span, or 37,500 lb. per panel per truss. The end panel load is assumed at 20,000 lb. A Cooper's E-40 will be taken for the live load. The impact allowance will be computed from the formula

$$I = L \frac{300}{l + 300}$$

in which I = impact stress, L = live load stress, and l = loaded length of span causing the live load stress.

TABLE 1

Member	Dead load		Live load						Combinations					
	Case I	Case II 30,000 lb. up- lift net	Case III		Case IV			Case V		I and III	II and IV or V	I and V		
			Left seg- ment	Right seg- ment	Left arm loaded		Right arm	Both arms loaded						
					Left seg- ment	Right seg- ment		Brok- en	Con- tinu- ous					
L_0-U_1	+ 26	- 39	-211 -141 -352	-180 -120 -300	+ 30 + 20 + 50			-352 + 18 -334	+ 26	-300 - 39 -339	+ 50 - 26 + 24			
U_1-U_2	+ 65	- 19	-208 -139 -347	-170 -113 -283	+ 38 + 25 + 63			-347 + 44 -303	+ 65	-283 - 19 -302	+ 63 - 12 + 51			
U_2-U_3	+254	+87	-208 -139 -347	-132 - 88 -220	+ 76 + 50 +126			-347 +169 -178	+254	-220 + 58 -162	+126 + 87 +213			
U_3-L_0	-271	-205	-211 -141 -352	-241 -161 -402	- 30 - 20 - 50	-271	-250 -125 -375	-352 -271 -623		-402 -205 -607		- 375 -271 - 646		
U_3-U_4	+569	+319	0	+115 + 77 +192	+115 + 77 +192	+230	+206 +103 +309		+569	+309 +319 +628		+309 +569 +878		
L_0-L_1	- 17	+25	+135 + 90 +225	+115 + 77 +192	- 19 - 13 - 32			+225 - 12 +213	- 17	+192 + 25 +217	- 32 + 16 - 16			
L_1-L_2	-144	- 19	+235 +157 +392	+178 +119 +297	- 57 - 38 - 95			+392 - 96 -296		+297 - 13 +284	- 95 - 19 -114			
L_2-L_3	-396	-187	+135 + 90 +225	- 4 - 3 - 7	+ 42 + 34 + 76	- 95 - 63 -158	-99		-396	-158 -187 -345		- 99 -396 -495		
U_1-L_2	- 75	- 10	- 11 - 10 - 21	+140 +100 +240	- 14 - 13 - 27	+113 + 81 +194	- 30 - 20 - 50	-44		+240 - 50 - 96	- 21 - 75 +187	+194 - 50 - 60	- 50 - 10 - 119	
L_2-U_2	+124	+59	+ 39 + 33 + 72	- 82 - 63 -145	+ 48 + 41 + 89	- 61 - 47 -108	+ 30 + 20 + 50	+78		+ 72 +124 +196	-145 + 82 - 63	-108 + 40 - 68	+ 89 + 59 +148	+ 78 +124 +202
U_2-L_2	-172	-107	- 82 - 63 -145	+ 39 + 33 + 72	- 99 - 76 -175	+ 27 + 23 + 50	- 30 - 20 - 50	-129	-106 - 53 -159	-145 -172 -317	-175 -107 -282		-159 -172 -331	
L_2-U_3	+221	+156	+140 +100 +240	- 11 - 10 - 21	+165 +118 +283	- 7 - 5 - 12	+ 30 + 20 + 50	+195	+185 + 98 +283	+240 +221 +461	+283 +156 +439		+283 +221 +504	
U_1-L_1	+ 38	+38	+ 76 + 65 +141		+ 76 + 65 +141					+141 + 88 +179				

Since the bridge is symmetrical about the center, the stresses will be computed for the left arm only. In Case III, this arm is considered as a span simply supported at L_0 and L_6 . The stresses are computed in the ordinary way. The results expressed in 1,000-lb. units are tabulated in Table 1; the impact stresses appearing directly below the corresponding live load stresses. Thus for the member U_1-U_3 the live load stress is -208,000 lb. and the impact stress is -139,000 lb. For the member L_2-U_3 , the live load and impact stress is +72,000 lb. when the left segment of the arm is loaded; and -145,000 lb. when the right segment of the arm is loaded.

In Cases IV and V the reactions, being statically indeterminate, cannot be accurately computed until the truss has been designed. In order that a preliminary design may be made, the reactions will be tentatively determined by assuming that the truss functions as a beam of uniform cross-section, continuous over three level supports. Only the end reactions R_0 are necessary. These are given in Table 2. By this process it is possible to compute the stresses and make a preliminary design, after which the true reactions may be determined.

TABLE 2

1 lb. at	R_0	1,000 lb. at	R_0
L_1	+0.793	L_7	-0.064
L_2	+0.593	L_8	-0.092
L_3	+0.406	L_9	-0.094
L_4	+0.241	L_{10}	-0.074
L_5	+0.103	L_{11}	-0.040

4. Positive Shear in Panel 0-1. *Case III.*—The influence line abc for shear in the panel is shown in Fig. 5b.

If P_1 = the load in panel 0-1, and P = the total load on the arm 0-6, the criterion for maximum positive shear in panel 0-1 is

$$P_1 \leq \frac{P}{6}$$

When the train is moving to the left, wheel 4 passing L_1 satisfies this criterion since P_1 is less than $\frac{P}{6}$ when wheel 4 is just to the right of L_1

and is greater than $\frac{P}{6}$ when wheel 4 is just to the left of L_1 . The maxi-

mum shear in the panel is found to be +162,000 lb. The area abc is 62.5 and the equivalent uniform load per linear foot is

$$q = \frac{162,000}{62.5} = 2,590 \text{ lb.}$$

Case IV.—The influence line for positive shear is *defghij* (Fig. 5c).

If P_1 = the load in panel 0-1, P_2 = the load in panel 1-2, and P_3 = the load in panel 2-3, etc., the criterion for maximum positive shear in panel 0-1 is

$$793P_1 \leq 200P_2 + 187P_3 + 165P_4 + 138P_5 + 103P_6$$

Try wheel 4 at L_1 , train moving to the left.

Wheel 4 approaching L_1

$793 P_1 = (793)(50) = 39,650$	$200P_2 = (200)(66) = 13,200$
	$187P_3 = (187)(56) = 10,472$
	$165P_4 = (165)(73) = 12,045$
	$138P_5 = (138)(57) = 7,866$
	$103P_6 = (103)(50) = 5,150$
	48,733

39,650 < 48,733 therefore the shear is increasing.

Wheel 4 having passed L_1

$793 P_1 = (793)(70) = 55,510$	$200P_2 = (200)(59) = 11,800$
	$187P_3 = (187)(43) = 8,041$
	$165P_4 = (165)(86) = 14,190$
	$138P_5 = (138)(44) = 6,072$
	$103P_6 = (103)(50) = 5,150$
	45,253

55,510 > 45,253, therefore the shear is decreasing.

When the train is moving to the left, wheel 4 at L_1 therefore satisfies the criterion for maximum positive shear in panel 0-1.

The shear may be computed by scaling the length of the ordinate in the influence line for each load, and taking the sum of the products of each load and its ordinate. Heretofore this has been the usual method of procedure. It requires that the influence line be drawn quite accurately to scale, and that considerable care be taken in scaling the ordinates. The shear may also be determined by taking the sum of each floor beam load and its corresponding ordinate as follows:

$(75.64)(0.793) = 60.0$
$(52.56)(0.593) = 31.2$
$(72.80)(0.406) = 29.6$
$(58.20)(0.241) = 14.0$
$(48.60)(0.103) = 5.0$

139.8 = maximum positive shear in panel 0-1.

A new and much shorter method, as outlined by Chas. A. Ellis in *Engineering News-Record*, June 9, 1921, will now be explained. If the influence line $defghij$ were straight from e to j , the criterion for maximum shear in panel 0-1 would be the same as for Case III. The difference between the broken line $efghij$ and a straight line from e to j is so slight in this or any similar truss that the criterion for maximum shear in the panel will, in general, place the train in the same position or approximately the same position, as will the criterion for Case III. A very close approximation to the shear of 139.8 lb. can be made very quickly, by assuming the same equivalent uniform load in both cases; or, in other words, by assuming that the shears in the panel for the two cases are directly proportional to the areas of the respective influence line diagrams. These areas are proportional to the sums of their respective ordinates, thus

$$\text{area } abc : \text{area } defghij :: 2.5 : 2.14$$

The shear in the panel for Case III was found to be 162 lb., hence the shear for Case IV is

$$(162)\left(\frac{2.14}{2.5}\right) = 138.3$$

This is a reasonably close approximation to the actual shear of 139.8 lb. previously determined.

It is now obvious that the stresses in L_0U_1 and L_0L_2 resulting from positive shear, may be quickly found by multiplying the stresses for Case III by the ratio $\frac{2.14}{2.5}$. This ratio for panel 0-1 remains the same for any bridge having six equal panels in each arm, irrespective of the length of the panel. The stresses for Case III are given in Table 1; and the live load stresses in L_0U_1 and L_0L_2 for Case IV are as follows:

$$L_0U_1 = (-211)\left(\frac{2.14}{2.5}\right) = -180$$

$$L_0L_2 = (+135)\left(\frac{2.14}{2.5}\right) = +115$$

The impact stresses for Case IV are determined in a similar manner.

The influence line for negative shear in panel 0-1 for Case IV is $jklmnop$, and since there is at present no corresponding area for Case III we shall leave this question to be considered later.

5. Positive Moment about U_3 . *Case III.*—The influence line abc for moment about U_3 is shown in Fig. 5d.

Let P_1 = the load on the segment 0-3, and P = the total load on the area 0-6, then the criterion for maximum moment about U_3 is

$$P_1 \leq \frac{P}{2}$$

Wheel 12 at L_3 satisfies this criterion, and the maximum moment about U_3 is 7,057 ft.-lb. Hence, the maximum live load stress in L_2L_4 is

$$\frac{7,057}{30} = +235$$

Case IV.—The influence line is $defghij$, Fig. 5e. If P_1 = the load in panel 0-1, P_2 = the load in panel 1-2, and P_3 = the load in panel 2-3, etc., the criterion for the maximum moment about U_3 , when reduced, is

$$379P_1 + 400P_2 + 439P_3 \leq 495P_4 + 414P_5 + 309P_6$$

Upon trial it will be found that wheel 12 at L_3 satisfies this criterion also. Multiplying each floor beam load by its corresponding ordinate

$$\begin{aligned} (75.20)(9.475) &= 713 \\ (51.92)(19.475) &= 1,011 \\ (74.52)(30.450) &= 2,269 \\ (56.56)(18.075) &= 1,022 \\ (48.80)(7.725) &= 377 \end{aligned}$$

$$\hline 5,392 = \text{maximum moment about } U_3.$$

The maximum tensile stress in L_2L_4 is

$$\frac{5,392}{30} = +179.7$$

This value may be closely approximated from Case III as follows: The ratio of the sum of the ordinates in Case IV to the sum of the ordinates in Case III is

$$\frac{85.2}{112.5} = 0.756$$

and

$$(235)(0.756) = +178 = \text{stress in } L_2L_4.$$

6. Negative Shear in Panel 0-1. *Case IV.*—We are now prepared to consider the negative shear in panel 0-1 when the right arm 6-12 is loaded. The influence line is $ijklmnop$ (Fig. 5c), and the criterion developed therefrom is

$$64P_7 + 28P_8 + 2P_9 \leq 20P_{10} + 34P_{11} + 40P_{12}$$

There are two positions of the train, when moving to the left, which satisfy this criterion, namely, wheel 11 at L_2 and wheel 8 at L_3 . The maximum negative shear, occurring when the train is in the latter position, is -22.8 lb., as found by taking the sum of the products of each floor beam load and its corresponding ordinate. This value may be closely approximated by the proportionate method, as follows: Since the influence line $ijklmnop$

(Fig. 5c) has its longest ordinate at the center of the arm, it will be compared with the influence line *abc* (Fig. 5d), which also has its longest ordinate at the center of the arm. The latter influence line is for the moment at U_3 for Case III, and the moment is 7,057. The ratio of the sum of the ordinates *ijklmnop* (Fig. 5c) to the sum of the ordinate *abc* (Fig. 5d) is

$$\frac{-0.364}{112.5} = -0.00324$$

and

$$(7,057)(-0.00324) = -22.9 = \text{shear in panel 0-1.}$$

This quantity represents also the maximum negative reaction at L_0 when the right arm is loaded, from which all the stresses may be determined as given in the designated column of Table 1.

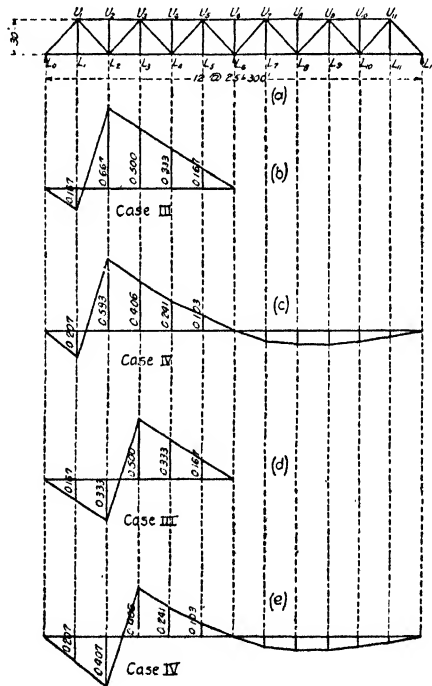

FIG. 6.

7. Shear in Panel 1-2.—The influence lines are shown in Figs. 6b and 6c. The stresses in U_1L_2 for Case III, as given in Table 1, are -11 and $+140$; from which the stresses for Case IV may be found as follows:

$$(-11)\left(\frac{0.207}{0.167}\right) = -14$$

$$(+140)\left(\frac{0.593 + 0.406 + 0.241 + 0.103}{0.667 + 0.500 + 0.333 + 0.167}\right) = +113$$

The stresses for Case IV, determined by the exact method, are -15 and $+113$ respectively.

8. Shear in Panel 2-3.—The influence lines are shown in Figs. 6*d* and 6*e*. The stresses in L_2U_3 for Case IV, determined by the proportionate method are

$$(+39)\left(\frac{0.207 + 0.407}{0.167 + 0.333}\right) = +48$$

$$(-82)\left(\frac{0.406 + 0.241 + 0.103}{0.500 + 0.333 + 0.167}\right) = -61$$

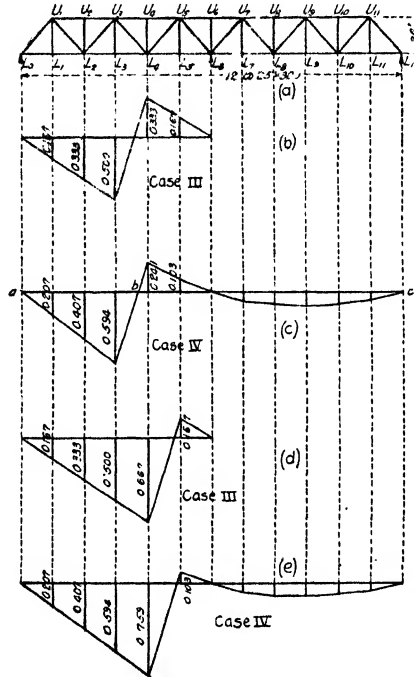

FIG. 7.

The stresses for Case IV, found by the exact method, are $+48$ and -60 respectively.

9. Shear in Panel 3-4.—The influence lines are shown in Figs. 7*b* and 7*c*. The stresses in U_3L_4 for Case IV, determined by the proportionate method, are

$$(-82)\left(\frac{0.207 + 0.407 + 0.594}{0.167 + 0.333 + 0.500}\right) = -99$$

$$(+39)\left(\frac{0.241 + 0.103}{0.333 + 0.167}\right) = +27$$

The stresses for Case IV, determined by the exact method are -101 and $+26$ respectively.

10. Shear in Panel 4-5.—The influence lines are shown in Figs. 7d and 7e. The stresses in $L_4 U_5$ for Case IV, determined by the proportionate method, are

$$(+140) \left(\frac{0.207 + 0.407 + 0.594 + 0.759}{0.167 + 0.333 + 0.500 + 0.667} \right) = +165$$

$$(-11) \left(\frac{0.103}{0.167} \right) = -7$$

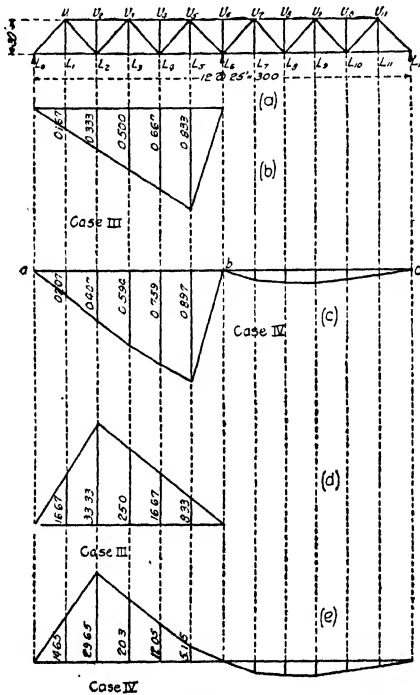

FIG. 8.

The stresses for Case IV, determined by the exact method, are $+167$ and -5 respectively.

11. Shear in Panel 5-6.—The influence lines are shown in Figs. 8b and 8c. The stress in $U_5 L_6$ for Case IV, determined by the proportionate method is

$$(-211) \left(\frac{0.207 + 0.407 + 0.594 + 0.759 + 0.897}{0.167 + 0.333 + 0.500 + 0.667 + 0.833} \right) = -241$$

The stress for Case IV, determined by the exact method is -241

12. Moment about L_3 .—The influence lines are shown in Figs. 8d and 8e. The stress in U_1U_3 for Case IV, determined by the proportionate method is

$$(-208) \left(\frac{81.8}{100} \right) = -170$$

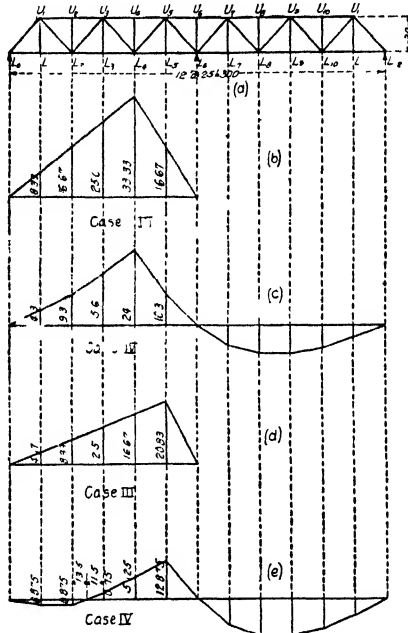

FIG. 9.

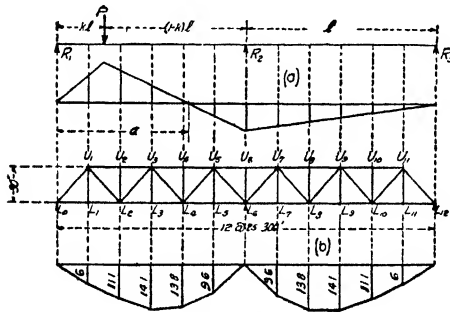

FIG. 10.

The stress for Case IV, determined by the exact method, is -172 .

13. Moment about L_4 .—The influence lines are shown in Figs. 9b and 9c. The stress in U_3U_5 for Case IV, determined by the proportionate method is

$$(-208) \left(\frac{63.6}{100} \right) = -132$$

The stress for Case IV, determined by the exact method, is -134 .

14. Moment about U_5 .—The influence lines are shown in Figs. 9d and 9e. Whenever each arm has six or more equal panels, the influence line for Case IV shows a reversal of stress in one or more chord members of the loaded arm adjacent to the center support.

This phenomenon is explained in connection with Fig. 10a, where a is the distance from R_1 to the point of zero bending moment, or

$$aR_1 = P(a - kl)$$

From the theorem of three moments,

$$R_1 = \frac{P}{4} (4 - 5k + k^3)$$

Hence

$$a = \frac{4l}{5 - k^2}$$

For any position of P , the limits of k are 0 and 1; hence, the limits of a are $\frac{4}{5}l$ and l . It is clear, therefore, that if any panel point experiences a negative moment from the influence load, the distance of that panel point from the center support must be less than one-fifth of the arm length. If the panels are of equal length, this condition can occur only when there are six or more panels in each arm.

The stresses for Case IV cannot be determined by the proportionate method as heretofore, on account of the dissimilarity of the influence line diagrams. In such instances the equivalent uniform load may be approximated by the use of an equivalent uniform load table. For the right segment, $l_1 = 25$, $l_2 = 61.5$ and the equivalent uniform load is 2.7; the area is 464 and the stress in L_4L_5 is

$$\frac{(464)(2.7)}{30} = +42$$

For the left segment, it will be sufficient to call $l_1 = l_2 = 30$, and the equivalent uniform load is 2.88. Hence, the stress is

$$\frac{(-38)(2.88)}{30} = -4$$

15. Moment about L_5 .—The influence line for Case IV is shown in Fig. 10b. There is no corresponding influence line for Case III. Since the influence is symmetrical about the center, the stress in U_5U_6 , when the left arm is loaded, is the same as previously determined when the right arm was loaded.

16. Case V, Both Arms Loaded. Broken Loads.—By referring to the influence lines in Figs. 5c, 5e, 8e, and 9c, it is apparent that the stresses in the members there considered will be less for Case V than for Case IV, since any load, brought on to the right arm while the left arm is loaded, will decrease the stress because the influence areas on opposite sides of

the center have opposite signs. In Figs. 6c, 6e, 7c, 7e, 8c, 9e and 10b the conditions are different, since loads on the right arm and the left segments of the left arm conspire, and the live load stress in any instance is the sum of the live stresses as given for Case IV. Consider the member U_3L_4 , for example, illustrated in Fig. 7. The live load stress is -99 when the left segment of the left arm is loaded, and -30 when the right arm is loaded; hence, if a train approaches on each arm, the maximum live load stress is -129 , as given in the column for broken loads. No impact is added when broken loads are considered. Specifications are not usually clear on the question of broken loads. If the location of the bridge is near a large freight terminal, it is conceivable that trains might occasionally approach simultaneously from both ends of the bridge.

Continuous Loads.—If Figs. 6 and 7 are taken consecutively, it is apparent that the positive influence line area for Case IV is decreasing. On Fig. 7c it becomes less than the negative area for the right arm, the difference in areas being 2.65. Therefore the stress in U_3L_4 for Case V will be greater than for Case IV.

The stress may be approximated as follows: Consider that the train moving to the left covers the whole span. Assume that the engine covers the segment ab and that the stress in U_3L_4 , on account of the engine, is the same as in Case IV or -99 lb. The shear in panel 3-4, on account of uniform train load of 2,000 lb. per lin. ft., from b to c is $(-2.65)(2) = -5.3$ lb., and the stress in U_3L_4 is $(-5.3)(1.3) = -6.9$. Hence the stress for Case V is $-99 - 6.9 = -105.9$. Similarly the stress in L_4U_5 is $+165 + (7.6)(2)(1.3) = +184.8$.

17. Negative Shear in Panel 5-6.—There is no positive area in the influence line for the continuous condition of Fig. 8c. The train must be moving to the left if the engines are to be on the segment ab , followed by a uniform train load on the segment bc . Since the segment ab is considerably longer than the length of the two engines, the shear in panel 5-6 for Cases III and IV would be considerably less if the engines were moving toward the left instead of in the opposite direction. We shall take this difference into consideration, by computing the negative shear in panel 5-6 when the train is moving to the left. This occurs when wheel 16 is at L_5 and the shear (Case III) is -151.7 lb., which is considerably less than -162 lb. when the train is moving to the right. Taking the same ratio of ordinates as before, the shear for Case V is

$$\begin{aligned} (-151.7) \left(\frac{2.864}{2.500} \right) &= -173.8 \\ (-9.1)(2) &= \frac{-18.2}{-192.0} \end{aligned}$$

The stress in U_5L_6 is $(-192.0)(1.3) = -249.6$.

18. Moment about L_6 .—The stress in U_5U_6 for Case IV was found to be +115. one arm being loaded. When the other arm is covered with a uniform train load of 2,000 lb. per ft., the additional stress is +91. Hence, the stress for U_5U_6 for Case V is +206.

19. Dead Load, Bridge Open. Case I.—The panel loads at each end are 20,000 lb. and all others 37,500 lb. Each truss is balanced on

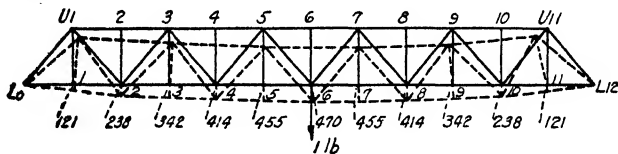

FIG. 11.

the center support and the stresses are statically determinate. They are given in Table 1.

20. Dead Load, Ends Raised. Case II.—The maximum negative reaction on account of live load was found to be -22.9, to which must be added -15.3 per impact, or a total of -38.2. Hence, if the positive uplift at each end is 38.2 or greater, there will be no hammering of one end when the train covers the opposite arm of the bridge. It will be assumed that the machinery parts are to be designed and adjusted so that the end wedges, when driven, will exert an upward pressure of 50. Since there is a dead load of 20 at the end panel point, the resultant or net positive end reaction is 30, and the resulting stresses are given in Table 2. If the truss were treated as fully continuous, the end reaction would be 86.4 instead of 50, and a heavier and more expensive lifting device would be required.

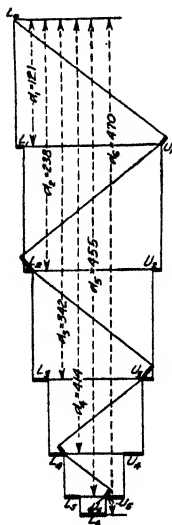

FIG. 12.

21. Combinations.—As previously explained, Case I is combined with either Case III or Case V; and Case II is combined with either Case IV or Case V. Only two-thirds of the dead load stress is taken when dead load and live load stresses have opposite signs. Many specifications are not clear upon the question of stress reversals. In treating reversals, each combination should be considered separately—that is, the largest positive stress

of one combination should not be considered with the largest negative stress of another combination. The members have been proportioned, and the gross cross-sectional areas are given in Table 3.

22. Reactions from Williot Diagram.—The quantities $\frac{Pl}{A}$ in Table 3, when divided by the modulus of elasticity E , are the strains in the various members when the center reaction is removed and the truss, supported

TABLE 3

Member	Length (inches)	Area (square inches) <i>A</i>	Stress (pounds) <i>P</i>	$\frac{Pl}{A}$	u_6	$\frac{Pu_6l}{A}$
<i>L</i> ₀ - <i>U</i> ₁	469	32.5	-0.652	-9.40	-0.652	+6.13
<i>U</i> ₁ - <i>U</i> ₂	300	30.5	-0.833	-8.20	-0.833	+6.84
<i>U</i> ₂ - <i>U</i> ₃	300	30.5	-0.833	-8.20	-0.833	+6.84
<i>U</i> ₃ - <i>U</i> ₄	300	30.5	-1.666	-16.40	-1.666	+27.35
<i>U</i> ₄ - <i>U</i> ₅	300	30.5	-1.666	-16.40	-1.666	+27.35
<i>U</i> ₅ - <i>U</i> ₆	300	68.2	-2.500	-10.99	+2.500	+27.46
<i>L</i> ₀ - <i>L</i> ₁	300	19.8	+0.416	+6.32	+0.426	+2.63
<i>L</i> ₁ - <i>L</i> ₂	300	19.8	+0.416	+6.32	+0.426	+2.63
<i>L</i> ₂ - <i>L</i> ₃	300	26.5	+1.250	+14.14	+1.250	+17.68
<i>L</i> ₃ - <i>L</i> ₄	300	26.5	+1.250	+14.14	+1.250	+17.68
<i>L</i> ₄ - <i>L</i> ₅	300	44.5	+2.083	+14.05	+2.083	+29.25
<i>L</i> ₅ - <i>L</i> ₆	300	44.5	+2.083	+14.05	+2.083	+29.25
<i>U</i> ₁ - <i>L</i> ₂	469	19.8	+0.652	+15.44	+0.652	+10.08
<i>L</i> ₂ - <i>U</i> ₃	469	19.8	-0.652	-15.44	-0.652	+10.08
<i>U</i> ₃ - <i>L</i> ₄	469	32.5	+0.652	+9.40	+0.652	+6.13
<i>L</i> ₄ - <i>U</i> ₅	469	44.5	-0.652	-6.88	-0.652	+4.49
<i>U</i> ₅ - <i>L</i> ₆	469	68.2	+0.652	+4.48	+0.652	+2.92
<i>U</i> ₁ - <i>L</i> ₁	0			
<i>U</i> ₂ - <i>L</i> ₂	0			
<i>U</i> ₃ - <i>L</i> ₃	0			
<i>U</i> ₄ - <i>L</i> ₄	0			
<i>U</i> ₅ - <i>L</i> ₅	0			
<i>U</i> ₆ - <i>L</i> ₆	0			

$$d_6 = \Sigma \frac{Pu_6l}{A} = \frac{234.79}{469.58} = 2$$

TABLE 4

1 lb. at	<i>R</i> ₀	1 lb. at	<i>R</i> ₀
<i>L</i> ₁	+0.788	<i>L</i> ₇	-0.068
<i>L</i> ₂	+0.581	<i>L</i> ₈	-0.108
<i>L</i> ₃	+0.386	<i>L</i> ₉	-0.114
<i>L</i> ₄	+0.226	<i>L</i> ₁₀	-0.088
<i>L</i> ₅	+0.099	<i>L</i> ₁₁	-0.046

at 0 and 12, carries a load of 1 lb. at joint 6 (Fig. 11). The Williot diagram is drawn in Fig. 12 by using the quantities $\frac{Pl}{A}$ to represent strains. The quantities *d* which are proportional to the deflections are indicated in Fig. 11. The deflection at the center has been checked in Table 3,

where P and u_6 necessarily have the same numerical values; but it should be remembered that P is measured in pounds, while u_6 is a ratio.

It is clear from Maxwell's Theorem that if 1 lb. at joint 6 causes the deflection $d_1 = 121$ at joint 1, then 1 lb. at joint 1 will cause the deflection $d_1 = 121$ at joint 6. Hence, with 1 lb. at joint 1, the reaction at joint 6, when the truss is continuous over the three supports, is

$$R_6 = \frac{121}{470} = 0.258$$

and from statics

$$R_0 = \frac{(1.0)(275) - (0.258)(150)}{300} = 0.788$$

The reactions at the left end, determined in the same manner, are given in Table 4.

If the accurate reactions in Table 4 are compared with the assumed reactions of Table 2, it will be apparent that the differences are comparatively small. The greatest percentage of error occurs when the load of 1 lb. is at the center of either arm. This comparison gives a fair idea of what error may be expected when the truss is assumed to be a beam of constant moment of inertia and no recognition is made of deflection due to shear.

The reactions for the preliminary design might be obtained by assuming that all members have the same cross-sectional area, which may be taken as 1 sq. in., and constructing a Williot diagram.

The combinations of stresses for Cases I and III determine the sizes of nearly all members, except the end post and chord members adjacent to the center support. Since the stresses for these cases are statically determinate, they might be used in making an estimate of the sizes of the members, and their areas used in constructing a Williot diagram.

The continuous girder formulas give such satisfactory results that a re-design is seldom necessary, except in a long span and then only for a few members adjacent to the center support.

RIM-BEARING SWING BRIDGES

23. General Considerations.—The trusses in a rim-bearing swing bridge are supported by a large circular girder, which rotates with the span. The girder rests on conical rollers, usually about 18 in. in diameter; and as many rollers are used as the circumferential length of the girder will permit, in order to give as many bearings for the girder as possible, and thereby minimize the deflection. The trusses may rest directly upon the circular girder or drum, as in Fig. 13b. This arrangement is undesirable, because it does not give an equal distribution of the load to the rollers. A better arrangement is shown in Fig. 13c, where

the truss loads are distributed to the drum at 8 points instead of at 4, as in the previous case. This arrangement gives a more even bearing. In the diagrams here shown, the center pivot receives neither dead nor live load. It is better to frame the structure so that from 15 to 20 per cent of the load is transmitted to the center pivot through radial girders. In any case each truss is supported at two points over the circular pier, as illustrated in Fig. 13a.

The reactions for the center-bearing bridge of the previous chapter were determined by assuming that the span functions as a beam of constant cross-section, continuous over three supports, no allowance being made for deflection due to shear. It was shown that the reactions thus computed by continuous girder formulas, compared very favorably with the true reactions determined after the design had been made. Such is not the case when the continuous girder formulas are applied to a swing span on four supports. These formulas give a negative reaction at L_7 and a positive at L_{13} when the left arm is loaded. This live load negative reaction, when the impact factor is added, is in many instances, numerically greater than the dead load positive reaction, indicating that a live load over the left arm would lift the truss from its support at L_7 . This assumption is not justified

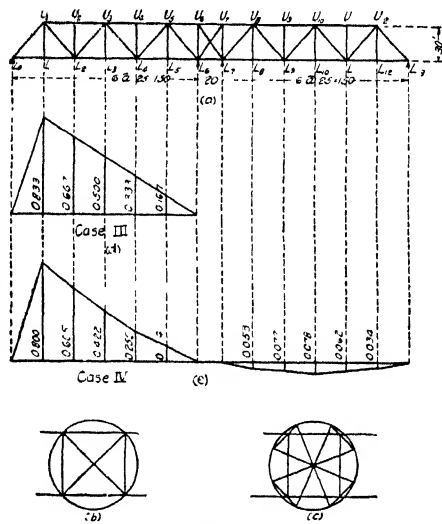

FIG. 13.

either by exact analysis, made after a truss is designed, or by observed data taken after erection.

24. Partial Continuity. Equal Moments at Center Supports.—It will be assumed that the diagonal bracing in panel 6-7 is so light that no appreciable shear can be transmitted through this panel. The shear in the panel is assumed zero under any condition of loading; hence $R_7 = -R_{13}$ for loads on the arm 0-6, and $R_6 = -R_0$ for any loads on the arm 6-13. For an influence load of 1 lb.

$$R_0 = (1 - k) - \frac{k - k^3}{4.8}$$

and

$$R_{13} = -\frac{k - k^3}{4.8}$$

The five cases of loading to be considered are the same as for a center-bearing bridge. The influence lines for shear in panel 0-1 for Cases III and IV are shown in Figs. 19*d* and 19*e*, respectively. If the live load is an E-40, the stresses for Case III will be the same as for the center-bearing bridge given in Table 1. The stresses for Cases IV and V may be found by the proportionate method. For example, the stress in L_0U_1 for Case III is -211 , hence, the stress for Case IV is

$$(-211) \left(\frac{0.800 + 0.605 + 0.422 + 0.256 + 0.114}{0.833 + 0.667 + 0.5 + 0.333 + 0.167} \right) = -185$$

The influence lines are drawn and the stresses computed for all the members, in precisely the same manner as for the center-bearing bridge. It may be noted that in this particular problem the positive shears are greater, and the negative shears less, in the rim-bearing type than in the center-bearing type. The stresses in some members will be greater, and in others less than in the center-bearing bridge. If, however, an independent design is made for the rim-bearing type, a comparison will show no appreciable difference in the two designs. For this reason it is a common practice to disregard the center panel when the stresses are computed. The diagonals in the center panel are light adjustable members, which serve only to provide stability to the structure when open, and resist a longitudinal wind pressure.

After the trusses have been designed, a sufficiently exact analysis of the reactions may be made by omitting the bracing in the center panel, removing the center supports, and drawing a Williot diagram for 1 lb. loads placed at L_6 and L_7 .

SECTION 4

CONTINUOUS BRIDGES

COPYRIGHT, 1923, 1943, BY D. B. STEINMAN

DESIGN AND ERECTION OF CONTINUOUS BRIDGES

The continuous truss is an excellent bridge type, offering decided advantages (under suitable conditions) over all other forms of construction. It is, of course, well known in its application to swing spans. Its general adoption for fixed spans has long been retarded by prejudices based on erroneous notions; but the successful execution of several notable examples in the last few years has served to dispel these prejudices, and the continuous truss has become established as an important type in American bridge practice.

1. Advantages of Continuous Bridges.—In comparison with simple spans, the continuous bridge offers the same advantages as the cantilever, namely:

- (1) Economy of material.
- (2) Suitability for erection of one or more spans without falsework.

In addition, the continuous bridge is superior to the cantilever in

- (3) Rigidity under traffic.
- (4) Less abrupt stress-changes under traffic.
- (5) Elimination of expensive and troublesome hinge-details.
- (6) Less extra material or hazard in erection.
- (7) Safety of the completed structure.

2. Economic Comparisons with Simple Spans.—The results of economic comparisons between continuous and simple spans will be materially affected by (1) the length of spans, (2) the system of web-bracing employed, and (3) the specification provision for reversal of stresses.

The relative economy of the continuous type increases with the length of span or, in general, with the ratio of dead load to live load. It is wrong to draw a general conclusion against the economy of continuous bridges based on a comparison for small spans (as Bender did in his book "Continuous Bridges" in 1876).

Furthermore, for a correct economic comparison, the most suitable system of web-bracing should be assumed for each respective type; a Pratt or Petit system may be most economical for the simple spans, but a

Warren system will generally yield the best results for the continuous truss.

Finally, the results of the economic comparison may be upset by the unscientific practice of imposing a stringent reversal clause; these reversal clauses as applied to the proportioning of main sections are relics of exploded fatigue theories, and should find no place in modern specifications for long-span bridges.

3. Economy of the Continuous Type.—A proper comparison with corresponding simple spans will generally show a substantial saving of material in favor of the continuous structure.

For the Sciotoville Bridge, consisting of two spans at 775 ft., the saving was found to be about 15 to 20 per cent.

According to comparative studies reported by Waddell, the economy of two 775-ft. continuous spans is 12 per cent for a railway structure and 22 per cent for a highway bridge; for railway spans of half the length (387.5 ft.), the saving is reduced to 7 per cent.

According to comparative studies reported by Winkler, the saving for continuous bridges of two, three, and four spans is 16, 19, and 21 per cent, respectively, when the span-length is about 325 ft; and 20, 24 and 28 per cent respectively, when the span-length is about 500 ft. (character of loading not stated, and no provision made for secondary stresses).

Generally, however, the economy of material is a minor consideration in the adoption of the continuous type, the deciding advantages being the convenience of cantilever erection and the increased stiffness of the structure.

4. Prejudices against the Continuous Type.—A common objection to the continuous bridge is its static indeterminateness. With modern methods of design and construction, however, it is possible to know the exact stresses in a continuous structure for any given conditions; the uncertainties can be made as small as in simple spans; and the extra labor of the computations is trifling, in itself, as well as in comparison with the advantages to be derived.

Another argument that has been frequently advanced against continuous construction is the possibility of change in the stresses as a result of settlement or compression of the piers or abutments. This argument would have some validity if the structure were supported on soft, yielding foundations. No bridge engineer, however, would consider building a continuous bridge on soft foundations, without provision for adjustment of the supports. Where rock foundations are available, the possibility of settlement may be omitted from consideration. Even if an appreciable unequal settlement does occur, the effect upon the stresses will generally be negligible, especially in longer spans. In the case of the Sciotoville Bridge, according to the writer's computations, an excess settlement of 1 in. at the middle support would change the reaction less

than four-tenths of 1 per cent. The effect of possible pier settlement on the stresses of continuous bridges has been grossly overestimated by former writers on the subject.

As a third objection, it is contended that the continuous truss is affected by temperature changes. The effect of expansion and contraction of intermediate piers is of the same nature as that of settlement of the supports; the stresses producible can be easily calculated, but in the case of long spans resting on shallow piers they will be found insignificant and negligible. The effect of unequal temperature changes in different parts of the trusses themselves can also be safely neglected. (In the case of the Sciotoville Bridge, a difference of 10° F. between top and bottom chords would change the end-reactions by only 1.5 per cent, and the middle reaction by only 0.7 per cent.) Uniform temperature changes in all the members of a continuous truss will cause no stresses.

5. Conditions Favorable for the Continuous Type.—The following conditions are particularly favorable to the economy and efficiency of the continuous bridge in comparison with other types: (1) Long spans; (2) good foundations; (3) piers of moderate height; (4) moderate truss depth; (5) spans approximately equal; and (6) cantilever erection. When the spans are long, the other requirements assume minor importance.

6. Economic Proportions and Number of Spans.—Both the economy and rigidity of the continuous type increase with the number of spans, but the gain beyond three or four spans is insignificant. Moreover, a larger number of spans would create difficulty in providing for expansion on account of the great length between expansion joints. Another objection is the greater number of supports at which jacking operations would be required during erection for adjustment of the reactions. (In a two-span bridge, only one support out of three requires jacking adjustment; in a five-span bridge, four supports out of six would require jacking.) For these considerations, the number of spans in a continuous group is preferably limited to three or four.

In a two-span bridge, the requirements of economy as well as of appearance are best satisfied by making the two spans equal in length.

In bridges of three or more spans, a symmetrical layout is also desirable for appearance and for shop economy.

In a three-span bridge, the economic ratio of spans is approximately 7:8:8, but considerable variations from these proportions will not materially affect the economy.

In a four-span bridge, the economic ratio of spans is approximately 3:4:4:4, but these proportions may also be varied considerably without materially affecting the economy.

In any cases, the span arrangement is determined by natural conditions of the crossing, or by the desire to utilize existing piers, rather than by economic or esthetic considerations.

7. History of Continuous Bridges.—The first representative of the continuous bridge type was the Britannia Bridge in England, built by Stephenson in 1848. It is a tubular plate-girder bridge of four spans: 230, 460, 460 and 230 ft. This was followed by several similar bridges, including the Torksey Bridge over the Trent (1849) with two spans of 130 ft., and the Bryne Bridge (1855) with three spans of 141, 267 and 141 ft.

In the latter part of the nineteenth century, continuous truss bridges were extensively built on the Continent. They were usually of the lattice-girder type with parallel chords, continuous over three to five spans. The Fades Viaduct in France (1908), with three spans of 378, 472 and 378 ft., had the longest continuous span prior to the building of the Sciotoville Bridge.

The Lachine Bridge, over the St. Lawrence River near Montreal, built in 1888 by C. Shaler Smith, with four spans of 269, 408, 408 and 269 ft., was the only continuous bridge in America before 1917. It was erected as a cantilever bridge, and then converted into a continuous truss for the live load. It was replaced in 1910 by a simple-span bridge.

The Sciotoville Bridge over the Ohio River, completed in 1917 with two spans of 775 ft., made a new record for span-length and established the continuous type in American bridge practice. Other large continuous bridges followed in rapid succession. The Allegheny River Bridge, near Pittsburgh, built in 1918, has three continuous spans of 272, 520, and 347 ft., followed by three continuous spans of 347, 350, and 272 ft. The Hudson Bay Railway Bridge over Nelson River at Kettle Rapids, also built in 1918, consists of three continuous spans of 300, 400, and 300 ft. The C. N. O. Railway Bridge over the Ohio River at Cincinnati, built in 1922, has three continuous spans of 300, 300 and 516 ft.

8. The Sciotoville Bridge.—The Ohio River Bridge of the Chesapeake and Ohio Northern Railway at Sciotoville, Ohio (Fig. 1), erected 1915 to 1917, is a double track bridge with the longest continuous spans in the world. In consequence of a bend in the river at the crossing, traffic follows the river channel along the Kentucky shore at low water, and shifts toward the outer or Ohio shore at high water; two spans of 775 ft. were necessary to satisfy the navigation requirements. The broken rock bottom only a few feet below low water afforded ideal foundation conditions for a continuous structure; this solution also offered maximum rigidity under railroad traffic, maximum economy in metal, and the important advantage of erection with a minimum of falsework. The out-cantilever adopted (Fig. 1) yielded a symmetrical and slightly skewed structure, which will give an impression of strength and rigidity.

The three piers rest on solid shale rock, with a maximum pressure of 9.5 tons per sq. ft. from vertical loads only, and 1.5 tons per sq. ft. with longitudinal force acting. The center pier, 1

the coping, resists the longitudinal force from the entire bridge and carries a vertical load of 16,400 tons. The shore piers, 12 by 57 ft. under the coping, carry only vertical loads of 5,100 tons. The piers are made of 1 2 4 concrete, reinforced with 1-in. square rods to prevent shrinkage and temperature cracks. The copings are reinforced longitudinally with I-beams to distribute the load from the bearings. The three piers contain about 15,000 cu. yd. of concrete and 250 tons of steel reinforcement, and cost \$165,000, or \$11 per cu. yd.

The stresses in the superstructure were calculated by the exact methods outlined in the next chapter, based on a live load of E-60, impact according to Lindenthal's formula, and dead load from actual weights calculated for each panel point. The average dead load is 18,200 lb. per lin. ft. of bridge, which included 700 lb. for the weight of each track. The distribution of the dead load over the spans is indicated in Fig. 2a. In addition, provision was made for a braking force of 60,000 lb. for each locomotive, or 1,000 lb. per lin. ft. for the whole train, a lateral force of 600 lb. per lin. ft., a stationary wind load of 1,500 lb. per lin. ft., and a moving wind load of 500 lb. per lin. ft. For stresses from wind + braking, the excess over 20 per cent of the total of all other stresses was considered. The members were proportioned for a basic unit stress of 20,000 lb. per sq. in. for the total of $D + L + I + \text{Lat.} + \text{Excess}$. The variation in sections of the

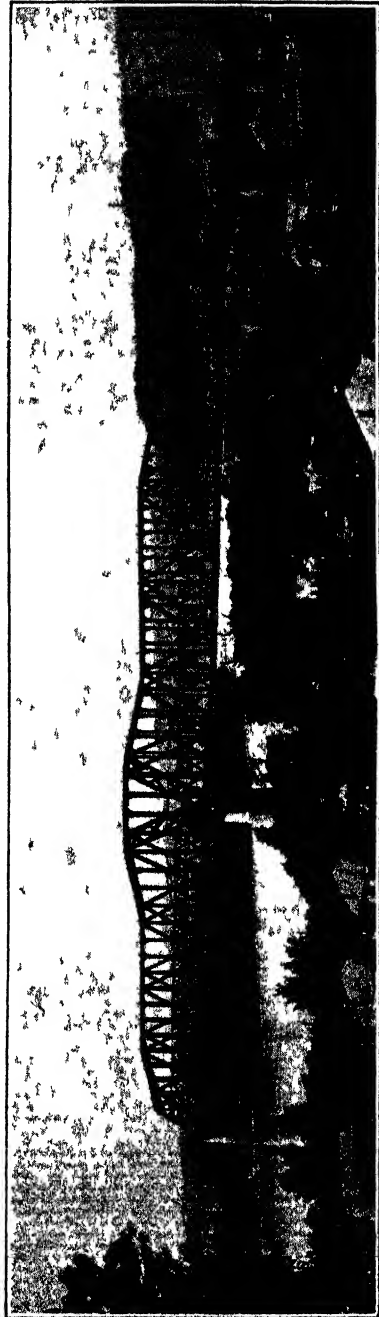
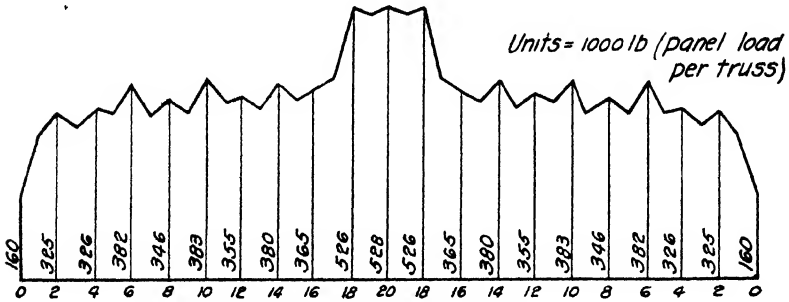
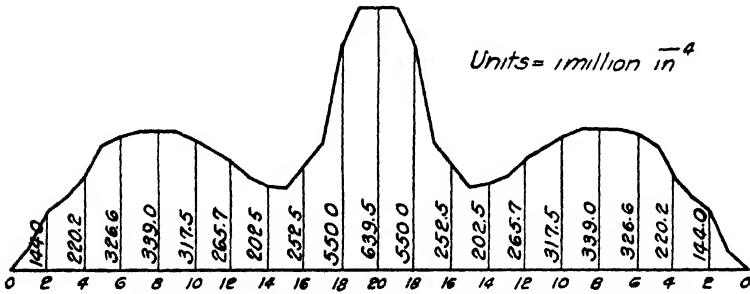

Fig. 1.—The Scotoville Bridge over the Ohio River Two continuous spans of 775 ft

main members and the resulting variation in moment of inertia of the truss are platted in Figs. 2b and 2c. The individual stresses and sections are given in a paper by Lindenthal in the *Proceedings*, Am. Soc. C. E., March, 1922, Plate V.



(a) Distribution of Dead Load



(b) Variation of Moment of Inertia (per truss)

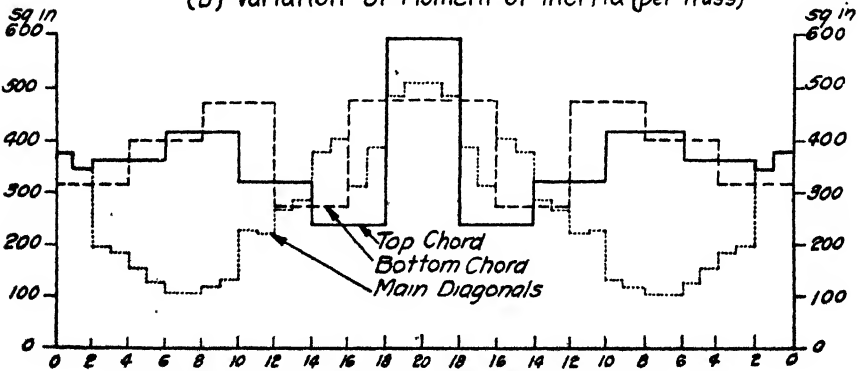

(c) Variation of Sections of Truss Members

FIG. 2.—Distribution graphs for the Sciotoville Bridge.

Ample lateral rigidity was secured by making the width between centers of trusses 38 ft. 9 in., or one-twentieth of the span-length, although a smaller width might have sufficed in view of the continuity of the lateral truss. The height at the middle of each span was made 103 ft. 4 in., or

approximately one-sixth of the length from the end pier to the point of contraflexure, since this length, about 80 per cent of the span, may be considered as a simple span. The height over the center pier was made 129 ft. 2 in., or one-sixth of the span-length, since the maximum moment at that point is about the same as at the center of a simple span. The height at the end was made 77 ft. 6 in., or equal to a double panel, in order to give the end-posts an inclination of not less than 45 deg. These three heights, in the ratio 3:4:5, also secured a pleasing outline for the continuous truss.

The Warren system adopted for the web bracing, with subdivided panels of 38 ft. 9 in., was found to be the most economical.

An alternative preliminary design, with pin-connected eyebars for the tension members, proved slightly cheaper, but the riveted truss design was adopted for its superior rigidity and durability.

All members have double webs and flange angles. The chords and inclined end-posts have solid cover plates. All the open sides of the members have rigid latticing of angles or channels. Transverse diaphragms, about 15 ft. apart, stiffen the members against distortion.

The web plates of the members stop at the gusset plates and are spliced to them with rivets in double shear; flange angles extend over the gussets. The gussets and webs are $1\frac{5}{8}$ in. thick at the main panel points ($3\frac{1}{4}$ in. at U18 and L20), and $1\frac{3}{16}$ in. thick at the secondary panel points. The largest gusset plates used are 135 in. by $1\frac{5}{8}$ in. by 14 ft. 9 in., and 140 in. by $1\frac{3}{16}$ in. by 18 ft. 2 in. In the main members, all rivets are 1 in. diameter (except $1\frac{1}{4}$ -in. rivets up to $7\frac{3}{8}$ in. grip at U18 and L20).

The longitudinal struts, which half-length the verticals, extend over two panels for better appearance. After erection, the connection at one end was loosened so as to allow the necessary sliding.

The lower lateral system forms with the bottom chords a two-span continuous truss. The upper lateral system in each span acts as a simple truss between the rigid portals over the piers.

To provide for unequal deflections of the trusses under one-sided loading, the usual sway frames of rigid cross-bracing were replaced by deep lattice frames combining strength with elastic stiffness.

The floorbeams are of exceptional design, in the form of U-shaped frames extending up to the struts. The available floor-depth was too shallow for an economical and stiff floorbeam of the usual type, figured as a simple span. As sufficient width was available, deep brackets were added and made continuous with the floorbeam so as to form an inverted two-hinged arch. This greatly reduced the bending moments in the horizontal portion and effected a material saving in weight, besides adding to the stiffness of the structure. The overhead strut takes up the horizontal thrust of the inverted arch.

To relieve the floorbeam flanges of the high stresses producible by braking and other longitudinal forces, a horizontal braking truss was provided in every panel in the plane of the lower laterals.

The bearings are of cast steel. The longitudinal expansion of the 1,550-ft. truss is divided between the two end bearings (Fig. 3). The center bearing is fixed, and has to take up the longitudinal force from braking and traction (2,520,000 lb. per truss). The bearing (Fig. 4) consists of a pedestal built-up of three separate castings in two tiers, and a shoe-casting bolted to the truss. To concentrate the reactions



FIG. 3.—End bearing, Sciotoville Bridge.

and permit the truss to deflect freely, the lower surface of the shoe-casting was planed convex to a radius of 1,150 in., while the top surface of the pedestal was finished to a perfect plane. To prevent horizontal creeping, the shoe-casting is secured to the pedestal by four steel dowels, 6-in. in diameter.

The greatest deflections of the trusses are 3 in. from full live load covering both spans and $4\frac{5}{8}$ in. (about 1:2,000 of the span-length) from full load covering only one span. The trusses were cambered so as to deflect to a straight line under dead load plus one-half live load.

Calculations made by the writer showed severe secondary stresses producible by dead load and live load, particularly over the middle support where the deflection diagram has a sharp upward kink. At this point, a bending stress of 21,400 lb. per sq. in. would be produced in the

bottom chord, were it not for the special method adopted to counteract the secondary stresses. This was accomplished by assembling and erecting the members to their geometric angles instead of to their cambered angles; so that, under the load $D + \frac{L}{2}$, the trusses assume their true geometric form and their members become straight and free from secondary stress. In other words, as a result of forcible initial bending

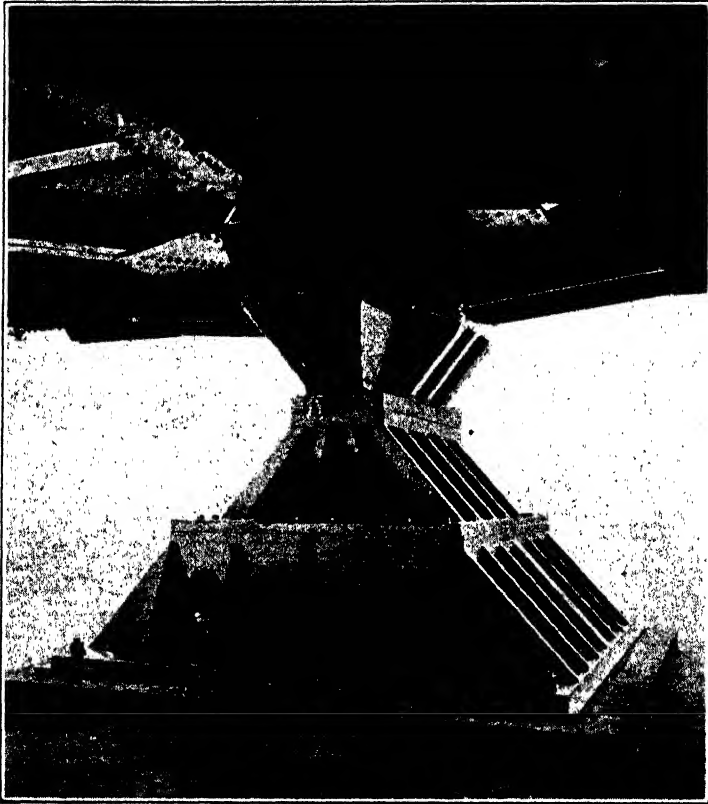

FIG. 4.—Center bearing, Sciotoville Bridge.

of the members in erection, the secondary stresses in this bridge decrease as live load comes on, and are fully neutralized under half live load.

The entire continuous bridge, 1,550 ft. long, contains 13,240 tons of steel. If riveted simple spans had been used, the weight would have been between 15,000 and 16,000 tons, or 13 to 20 per cent heavier than the continuous design.

A more complete account of the bridge is given in Lindenthal's paper presented before the American Society of Civil Engineers, April, 1922.

9. **Erection of the Sciotoville Bridge.**—Shop assembling of the truss connections was required by the specifications. The trusses were assembled in sections, connecting the web members to each chord separately.

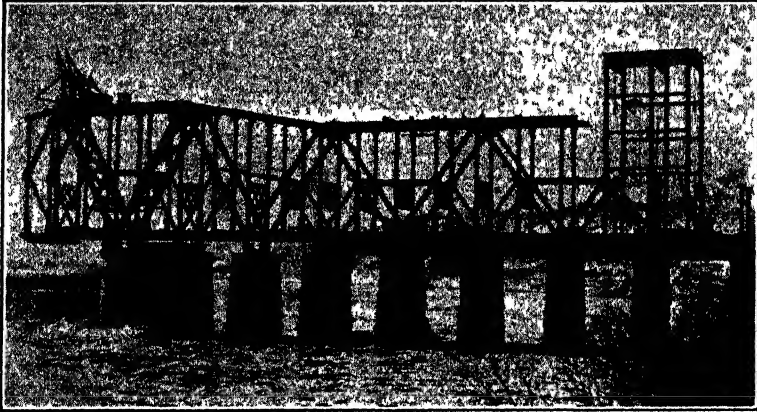

FIG. 5.—Sciotoville Bridge—Erection of Ohio span on falsework

The members were carefully leveled and laid out with a transit to the exact "geometric" angles, and the distances were carefully checked with a steel tape; all rivet holes were reamed or drilled with the members so assembled.

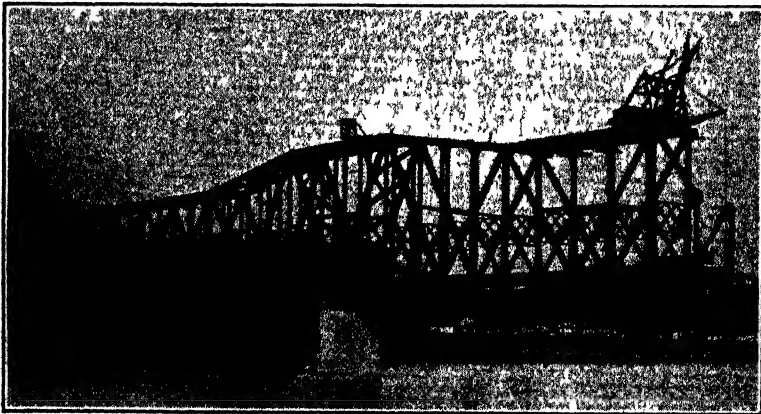

FIG. 6.—Sciotoville Bridge—Cantilever erection of Kentucky span.

The Ohio span was erected on falsework, as the river was shallow and no opening for navigation was required under that span. On account of the rock bottom, no piles could be driven; and, to minimize the danger of the falsework being carried away by sudden flood, narrow falsework

towers under the main panel points were used instead of closely spaced bents, leaving 60-ft. openings for the passage of drift and ice (Fig. 5).

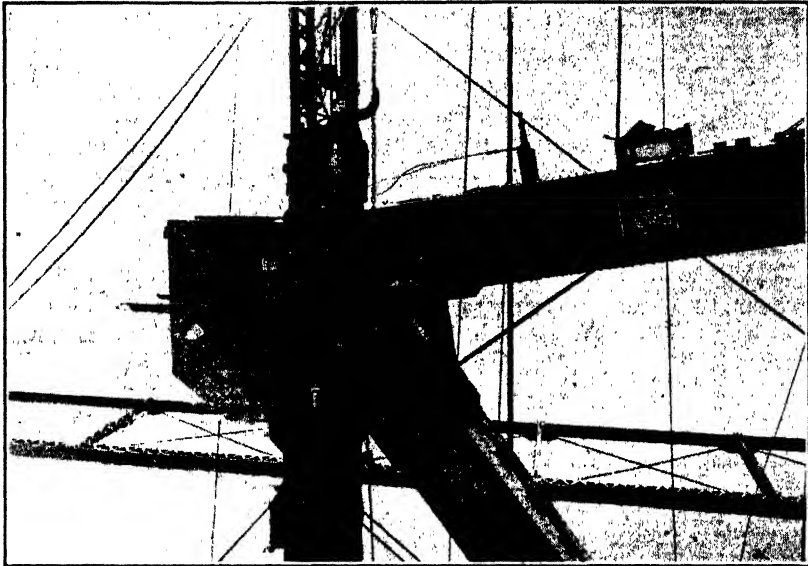

FIG. 7.—Sciotoville Bridge—Jacking apparatus for bending members at connections.

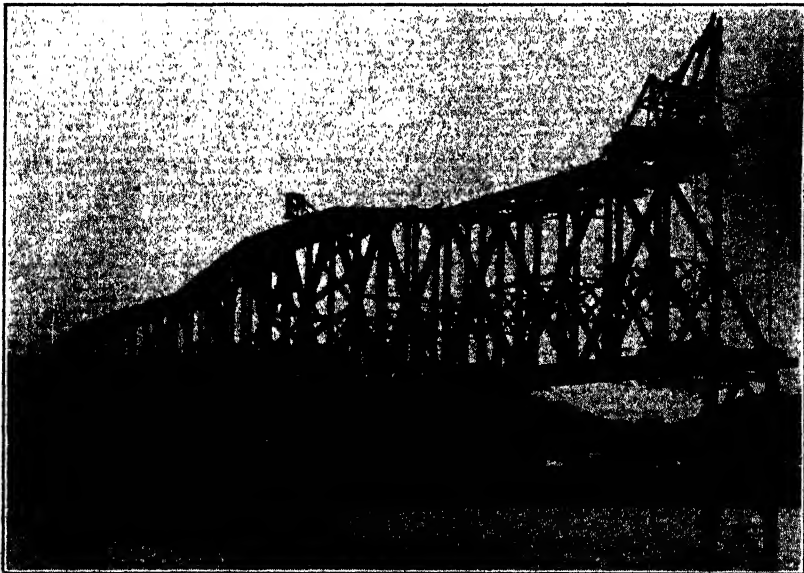

FIG. 8.—Sciotoville Bridge—Kentucky span reaching temporary bent at L8.

On the Kentucky side, a minimum clear channel of 420 ft. was required for navigation; consequently cantilever erection was adopted (Fig. 6).

Since the erection of the entire 20 panels as a cantilever would have necessitated heavy additions to the truss members near the middle pier, it was decided to reduce the free cantilever erection to 12 panels (465 ft.) by placing steel bents as intermediate supports at the eighth and fourth panel points from the Kentucky end (Figs. 8 and 9).

The outstanding feature of the erection of this bridge was the initial bending of the members for the neutralization of the final secondary stresses. For these bending operations and for the adjustments in height of the trusses at the end piers and at the temporary intermediate supports, elaborate preparations and special jacking devices (Fig. 7) were required.

The general erection procedure was as follows: By means of a gantry traveler (Fig. 5), the falsework and, on it, the steel floor system and

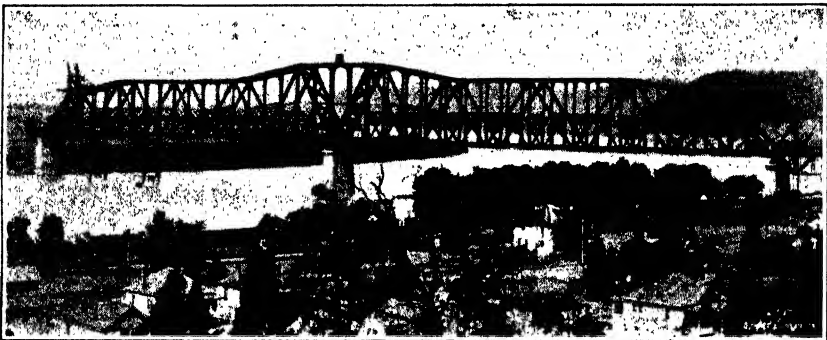

FIG. 9.—Sciotoville Bridge—Kentucky span resting on temporary bents at L8 and L4.

delivery tracks were laid from the Ohio pier to the center pier. On the return trip toward the Ohio pier, the traveler laid the bottom chords. These were at once riveted while lying in a straight line, and then jacked to the desired camber with the Ohio end $8\frac{1}{4}$ in. lower than its final position.

The traveler was then raised to its full height and brought back to the center pier, whence it proceeded with the erection of the trusses toward the Ohio end (Fig. 5).

In the meantime, a creeper-traveler had been assembled on top of the trusses over the center pier for the erection of the Kentucky span. As the creeper-traveler proceeded with the cantilever erection, the timber falsework under the completed Ohio span was gradually removed, leaving only the steel columns under panel points 4, 8, 12 and 16 to support the trusses (Fig. 6). These columns were finally released, when the Kentucky cantilever had reached about mid-span, by jacking the Ohio end of the span to its final position (using one 500-ton and four 200-ton jacks under each truss).

When the Kentucky cantilever reached the steel bent prepared at L8 (Fig. 8), it was jacked up $7\frac{3}{8}$ in. at that point, and when the truss reached the next bent, at L4, it was jacked up 1 in. at that point. When the Kentucky pier was reached (Fig. 9), the truss was jacked up $16\frac{1}{4}$ in. to its final position on the rocker bearings, thereby releasing the intermediate supports. The final jacking force (about 1,200 tons) checked the calculated reactions, insuring the correctness of the predetermined stresses without further adjustment.

The erection of the steelwork (13,240 tons) was completed in 14 months.

The writer was special assistant to Gustav Lindenthal, Consulting Engineer, during the planning and execution of this work.

10. The Allegheny River Continuous Bridge.—The new Allegheny River Bridge for the Bessemer and Lake Erie Railroad, built in 1918, is a double track deck structure with three continuous spans of 272, 520, and 347 ft., followed by three continuous spans of 347, 350 and 272 ft. (see Fig. 10).

The necessity for cantilever erection and the importance of minimum weight were the governing conditions which fixed the choice on the continuous type; this solution also proved the cheapest. Simple spans would have required considerable extra material for erection stresses and a cantilever design, besides being undesirable for the short spans and heavy live load, was not adapted to the requirement of erecting from one end of each span. The number of spans to be connected in a single, continuous structure was limited to three, in order to avoid the complication of having too many pier reactions to adjust; grouping three spans in each continuous structure, only the two end-reactions of a group had to be weighed off by jacks and gages to the predetermined amounts.

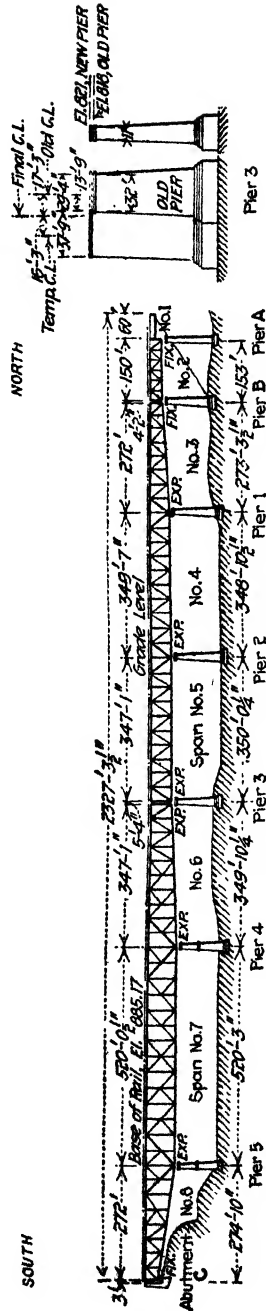

Fig. 10.—Diagram of the continuous bridge over the Allegheny River.

A special feature of the structure is a counterweight at the end of the south span to counteract uplift from live load on the adjoining span, 520 ft. long. The counterweight consists of a 350-ton block of concrete, molded around the end sway-frame and occupying the full width and height below the deck floorbeam. The necessity for this counterweight would have been avoided if the end-span could have been made longer.

Silicon steel was used for the stiff truss members (subject to reversal of stress), and a specially treated steel was used for the eyebars. These materials furnished the cheapest bridge at the prevailing prices. The comparative estimates were based on unit stresses of 16,000 for ordinary steel, 40 per cent higher stresses for silicon steel, and 27,000 lb. per sq. in. for the eyebars. (The eyebars showed results in full-size tests of 53,000 to 63,000 elastic limit, and 81,000 to 90,000 ultimate strength.)

The design of the bridge was based on Cooper's E-75 loading to provide for the existing heavy ore trains with an anticipated increase for 15 or 20 years. A first approximation to the required distribution of metal was obtained by employing ordinary continuous-girder formulas based on constant moment of inertia. The resulting design was then analyzed, corrected and re-analyzed by deflection calculations. The dead load reactions, however, were fixed arbitrarily at an early stage of the calculations, and then secured by jacking in the final erection adjustment.

For the members which get their maximum stresses under broken load, the permissible working stress was increased 25 per cent as allowance for the improbability of occurrence of short, separated lengths of train occupying just the panels required. Members and connections subject to reversal of stress were designed for the maximum stress in each direction augmented by 50 per cent of the smaller.

Severe wind loads were assumed, and the unit stresses for combined wind and vertical load were increased 25 per cent above those normally allowed.

In order to relieve the pier masonry of braking forces, the bearings on all the river piers are provided with expansion rollers, the two ends of the bridge being fixed. At the intermediate bearings, 24-in. rockers are carried on a grillage resting on the pier girders, and the truss panel point serves as upper shoe. To this panel-point assemblage (Fig. 11), the four abutting truss members are pin-connected, producing the equivalent of a pin-bearing support and eliminating the high secondary stresses that would arise in a continuous chord.

The steel weight of the bridge is about 10,150 tons, or 8,700 lb. per lin. ft.

The truss diagram (Fig. 10) and the typical details (Fig. 11) are reproduced from a description of the structure in *Engineering News-Record*, May 2, 1918.

11. Erection of the Allegheny River Bridge.—The two-track continuous bridge (Fig. 10) of the Bessemer and Lake Erie Railroad over the Allegheny River, built in 1918, replaced a light, single track structure of simple spans.

A method of building on the existing alignment with use of the old piers and without interrupting traffic, was developed. The replacement was made as follows: The single track piers were widened on the old footings, which had been built of double track width originally. The new bridge was then erected alongside the old one, since the widened piers, with the help of pier girders, were long enough to accommodate both structures side by side. Traffic was then transferred to the new bridge, and the old one was dismantled. Finally, the new bridge was rolled over into central position on the piers.

The erection of the new bridge was begun at the two ends, by building the shore spans on falsework. All the other spans were erected by continuous cantilever operation to closure at the middle of the 520-ft. span.

In the cantilever erection, as soon as each span was landed, it was jacked up to correct level. From the fixed bearing at the north end to pier 1 (Fig. 10), the first span was erected on falsework and served as an anchor span; when the second span reached pier 2, it had to be jacked up 40 in.; when the third span reached pier 3 it had to be jacked up 42 in.; when the fourth span, with temporary top-chord links connecting it to the preceding span, reached pier 4, it had to be jacked up 43 in. to permit removal of the links, and was then lowered to position on the pier. In the meantime, the south shore span had been erected on false work from the south abutment to pier 5, leaving the 520-ft. span to be erected by cantilevering from pier 4 and pier 5 to junction at mid-span. For this cantilever operation, the rocker bearings on piers 4 and 5 were rendered fixed by bolting on temporary side-plates (after the two halves of the structure had been pushed forward several inches, and the rear ends had been lowered to tip the forward ends up). To close the span, the bottom-chord eyebars, which are joined at the middle, were inserted and allowed to hang slack; the top-chord closing section was then dropped into place and the anchor-ends of the arms were jacked up until the top-chord joints came to bearing; the rocker bearings on the main piers were then released by taking off the fixing plates, so that the trusses might move backward at these points as the jacking continued until the eyebars were put into the desired tension.

Finally, the old bridge was dismantled and the new bridge was rolled into central position on the piers, the two groups of three continuous spans being moved successively.

12. The Nelson River Continuous Bridge.—A three-span continuous bridge, 1,000 ft. long, was erected in 1918 for the single track crossing

of the Hudson Bay Railway over the Nelson River at Kettle Rapids (Figs. 12 and 12A). Rapid current, a deep channel, and severe ice conditions precluded the use of falsework for the channel span; the rock foundations for the piers and abutments assured the permanence of the structural adjustment. These physical conditions gave the continuous structure a distinct superiority over other types; careful comparison with simple span and cantilever designs showed maximum economy for the continuous type as well as maximum simplicity in shopwork and in erection. Two islands at the point of crossing provided foundations for the intermediate piers, reducing the spans to 300, 400, and 300 ft.

Parallel chord trusses were adopted to simplify the design and fabrication, and to facilitate speedy erection. The trusses, only 15 ft. above high water and ice (for economy in pier masonry), are 50 ft. deep and are spaced 24 ft. apart. Warren webbing was adopted because it is most economical for the alternating stresses and because of its simplicity and good appearance. A 45-deg. slope for the diagonals made the main panel length 100 ft., and intermediate verticals and sub-panelling reduced the panels to 25 ft. (see Fig. 12).

The approach track grades brought the bridge floor near mid-height of the trusses; and this yielded incidental advantages in simplifying floorbeam connection, in improving stress distribution, and in reducing stringer stresses due to chord elongation.

The bridge was designed for a live load slightly less than Cooper's E-50, and for a total wind load of 800 lb. per lin. ft. The basic working stress was 16,000 lb. per sq. in. for tension, and 12,000 for compression. Provision for impact and reversal effects was made by the impact formula

$$I = \frac{(L + 0.4L')^2}{L + D}$$

where L = the greater and L' the lesser live load stress.

All four bearings are of the pin type, the upper and lower shoes being steel castings. One of the two pier bearings is fixed; all the other bearings have expansion rollers.

Figures 12 and 12A, giving the general elevation of the bridge and the stress-sheet of the main span, is reproduced from a description of the structure in *Engineering News-Record*, Aug. 29, 1918.

13. Erection of the Nelson River Bridge.—The trusses of the Nelson River Bridge (Fig. 12) were given an arbitrary camber by lengthening each top-chord panel $\frac{3}{8}$ in. The bridge had to be erected with its ends low to permit junction at midstream, and provision for jacking up the bearings was necessary for adjustment of the structure to the desired stress conditions. The floorbeams over the four supports were made strong enough to serve as jacking girders for this purpose.

Commencing at the south end, a 75-ton derrick car with 50-ft. boom erected the members of the southern anchor span on false work. After

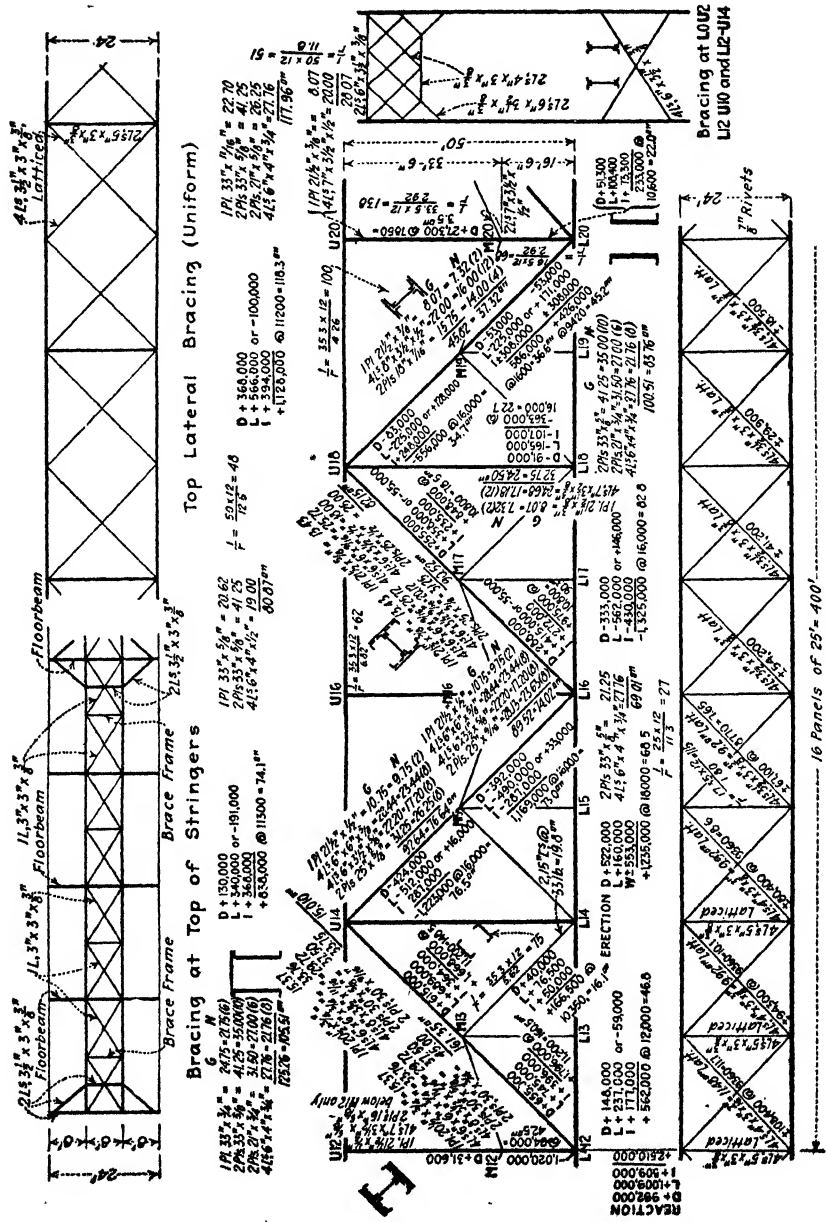

Fig. 12.—Nelson River Bridge—Stress sheet.

reactions, an approximate value was assumed for one of the end-reactions and the corresponding end of the bridge was jacked until the desired value was attained.

The steel erection was completed in February, 1922, one year after the foundation work began.

STRESSES IN CONTINUOUS BRIDGES

✓ **15. The Elastic Curve.**—The first step in the analysis of a continuous bridge is the construction of the influence line for one of the unknown reactions. This influence line can then be used as a foundation for quickly drawing the influence diagrams for all the stresses in the structure.

This reaction influence line may be constructed as the deflection diagram produced by a unit displacement at the point of application and in the direction of the desired reaction. Since this deflection polygon or curve is independent of the actual loading to which the structure may be subjected, but depends only upon the elastic relations within the structure, it is appropriately named the "elastic curve."

The elastic curve epitomizes the elastic behavior of the structure, and is the key to all stress determinations.

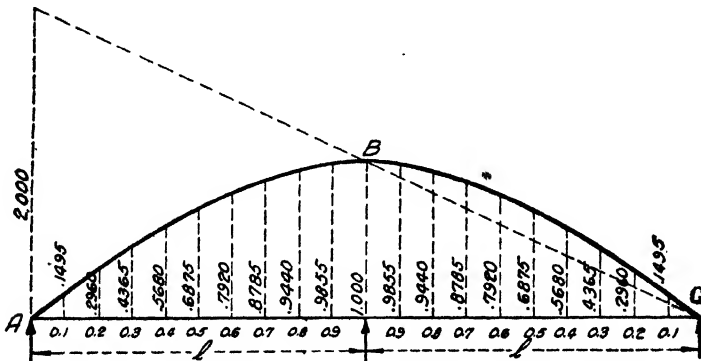

FIG. 13.—Elastic curve for middle reaction. (Continuous girder of two equal spans—uniform I).

✓ **16. Elastic Curves for Constant I .**—For preliminary designs it is customary to assume a constant moment of inertia I throughout the length of the structure.

If a beam of constant I , continuous over two equal spans, is subjected to a unit displacement (by a concentrated force) at the middle support, the resulting deflection curve will be as in Fig. 13.

This will be the "elastic curve" for the middle reaction, and can be used as the influence-line for that reaction. Thus a load P at the middle support will produce a reaction, $B = 1 \cdot P$; and a load P at the middle of either span ($x = 0.5l$) will produce a reaction, $B = 1\frac{1}{16}P = 0.6875P$.

The ordinates at the one-tenth points of the two spans are indicated in the diagram. At any point $x = kl$, the ordinate will be

$$y = \frac{3}{2}k - \frac{1}{2}k^3 \tag{1}$$

The influence area between the elastic curve (Fig. 13) and its chord AC amounts to 1.25*l*. Hence, a uniform load (*w* per lineal unit) covering the entire bridge will produce a middle reaction equal to 1.25 *wl* or five-eighths of the entire load; and each end-reaction will be 0.375 *wl*, or three-sixteenths of the total load.

Each half of the elastic curve in Fig. 13 is identical with the elastic curve of a beam fixed at one end and simply supported at the other.

The whole curve (Fig. 13) is identical with the curve assumed by a uniform beam supported at the ends A, C when deflected by a concentrated load applied at mid-length B . Accordingly, the elastic curve can be obtained mechanically, without computation, by using a uniform, straight spline with pins for end supports; when the middle point is moved through a unit distance, the spline assumes the desired elastic curve and the ordinates can be measured.

If the reaction points B and C are supported and the free end A is displaced through a unit distance, the resulting "elastic curve" (Fig. 14) will be the influence line for the end-reaction, A .

This influence line is more directly applicable in the analysis of the structure than the preceding curve, Fig. 13.

A load P over the end A will produce a reaction, $A = (1)(P)$. As the load moves across the first span, the reaction diminishes; when P is at mid-span, the reaction is $A = \frac{13}{32}P = 0.40625P$. As the load passes the middle support B , the reaction A reverses in sign; when P comes to the middle of the second span, $B-C$, the reaction becomes $A = -\frac{3}{32}P = -0.09375P$; and when the concentration reaches the end support C , the reaction A becomes zero again.

The ordinates at the one-tenth points of the two spans are indicated in the diagram (Fig. 14). At any point, $x = kl$, in the first span, the ordinate will be

$$y = 1 - \frac{5}{4}k + \frac{1}{4}k^3 \tag{2}$$

and at any point, $x = kl$, in the second span (x being measured from the free end), the ordinate will be

$$y = -\frac{1}{4}(k - k^3) \tag{3}$$

The elastic curve in Fig. 14 is really the same as the elastic curve in Fig. 13, referred to the chord $B-C$ instead of $A-C$; and the ordinates for Fig. 14 may be obtained by measuring or figuring the intercepts between the curve in Fig. 13 and its chord $B-C$ (and then dividing by 2).

The influence area between the elastic curve (Fig. 14) and its chord $B-C$ amounts to $+0.4375l - 0.0625l = 0.375l$, or $+\frac{1}{16}l - \frac{1}{16}l = \frac{3}{8}l$.

Hence, when a uniform load w (per unit length) covers the first span, the reaction $A = \frac{7}{16}wl$; when it covers the second span, the reaction $A = -\frac{1}{16}wl$; and when it covers both spans, the reaction $A = \frac{3}{8}wl$. Areas

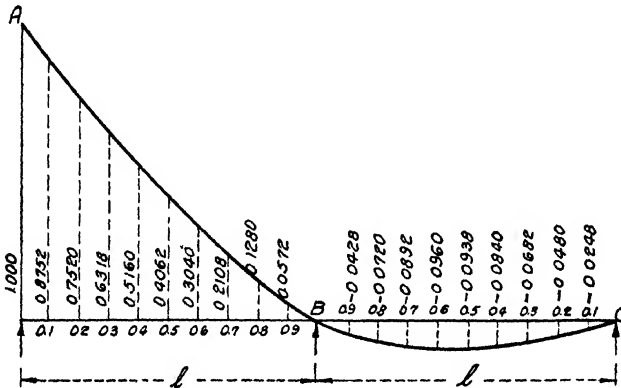

FIG. 14.—Elastic curve for end reaction. (Continuous girder of two equal spans—uniform l).

below the elastic curve represent positive contributions to the reaction A , and areas above the curve represent negative contributions to the reaction. All areas are given exactly by Simpson's Rule.

The elastic curve, Fig. 14, may also be obtained mechanically by using a spline; when the points B and C are held against pins, and the end A is bent through a unit distance, the spline assumes the desired elastic curve and the ordinates can be measured.

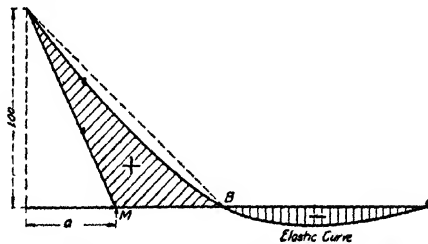

FIG. 15.—Influence diagram for bending moments at M . (Bridge continuous over three supports).

17. Influence Diagram for Bending Moments.—The elastic curve (Fig. 14) is an influence line for the end-reaction, A .

To obtain the influence diagram for bending moments at any point M , distant a from the end of the span, simply draw a straight line joining A and M (Fig. 15).

The ordinates or areas of the resulting diagram, Fig. 15, must be multiplied by a to give bending moments at M . The factor a is the influence constant of this diagram. Areas below the elastic curve represent posi-

tive bending moments, and areas above the curve represent negative bending moments.

If the line $A-M$ does not cross the curve $A-B$, the first span must be fully loaded for maximum positive bending moment, and the second span must be fully loaded for maximum negative bending moment. The resulting values (for a uniform load w) will be

$$\text{Max. } M = wa(\frac{7}{16}l - a/2) \tag{4}$$

$$\text{Min. } M = -wa(\frac{7}{16}l) \tag{5}$$

$$\text{Total } M = wa(\frac{3}{8}l - \frac{1}{2}a) \tag{6}$$

For a uniform load (w) covering both spans, there is a point of contraflexure (Total $M = 0$) at $a = \frac{3}{4}l$; and a maximum bending moment (Total $M = \text{maximum} = \frac{9}{128}wl^2 = 0.0703wl^2$) at $a = \frac{3}{8}l$.

For a uniform load w covering the first span only, there is a point of contraflexure ($M = 0$) at $a = \frac{7}{8}l$; and a maximum bending moment (Max. $M = \text{maximum} = \frac{49}{128}wl^2 = 0.0957wl^2$) at $a = \frac{7}{16}l$.

When a exceeds $0.8l$ the line $A-M$ crosses the curve $A-B$, giving a load-division point. The critical point, $a = 0.8l$, is called the "fixed point" of the span.

For bending moments over the middle support B , ($a = l$), the line $A-M$ (Fig. 15) takes the position $A-B$. The influence diagram then consists of two negative areas each equal to $\frac{1}{16}l$, and the bending moment for full loading will be, Total $M = -\frac{1}{8}wl^2$.

We thus find the following values for maximum, minimum, and total bending moments at the one-tenth points of the span (Table 1).

TABLE 1.—BENDING MOMENTS IN CONTINUOUS GIRDER OF TWO EQUAL SPANS (ASSUMING UNIFORM I)

Point	Max. M	Min. M	Total M
$a = 0$	0	0	0
$a = 0.1l$	$+0.0388wl^2$	$-0.0062wl^2$	$+0.0325wl^2$
$a = 0.2l$	$+0.0675wl^2$	$-0.0125wl^2$	$+0.0550wl^2$
$a = 0.3l$	$+0.0862wl^2$	$-0.0188wl^2$	$+0.0675wl^2$
$a = 0.4l$	$+0.0950wl^2$	$-0.0250wl^2$	$+0.0700wl^2$
$a = 0.5l$	$+0.0938wl^2$	$-0.0312wl^2$	$+0.0625wl^2$
$a = 0.6l$	$+0.0825wl^2$	$-0.0375wl^2$	$+0.0450wl^2$
$a = 0.7l$	$+0.0612wl^2$	$-0.0438wl^2$	$+0.0175wl^2$
$a = 0.8l$	$+0.0300wl^2$	$-0.0500wl^2$	$-0.0200wl^2$
$a = 0.9l$	$+0.0061wl^2$	$-0.0736wl^2$	$-0.0675wl^2$
$a = l$	0	$-0.1250wl^2$	$-0.1250wl^2$

For Live Load

For Dead Load

The bending moments due to uniform dead load are given by the formula or tabular values for Total M . For variable dead load, it will be most expeditious to first determine the end-reaction A (by taking the algebraic sum of the products of the panel concentrations by the respective ordinates of the elastic curve, Fig. 14), and then to calculate the shears and bending moments in the ordinary manner.

18. Influence Diagram for Shears.—The influence diagram for shears at any section S of a continuous girder, is obtained by simply drawing a vertical line of unit height through the corresponding point of the elastic curve, Fig. 16.

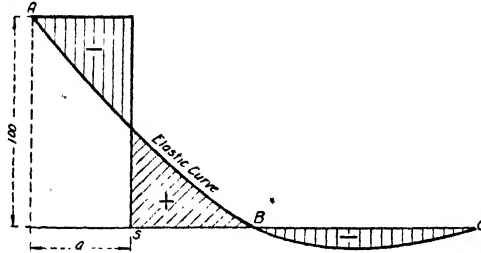

FIG. 16.—Influence diagram for shears at S . (Girder continuous over three supports).

Areas below the elastic curve represent positive shears, and areas above the curve represent negative shears. The constant of this influence diagram is unity.

For maximum positive shears (Max. V), load the segment S - B ; for maximum negative shears (Min. V), load the segments A - S and B - C .

TABLE 2.—SHEARS IN CONTINUOUS GIRDER OF TWO EQUAL SPANS (ASSUMING UNIFORM I)

Point	Max. V	Min. V	Total V
$a = 0$	$+0.4375 wl$	$-0.0625 wl$	$+0.3750 wl$
$a = 0.1l$	$+0.3437 wl$	$-0.0687 wl$	$+0.2750 wl$
$a = 0.2l$	$+0.2624 wl$	$-0.0874 wl$	$+0.1750 wl$
$a = 0.3l$	$+0.1932 wl$	$-0.1182 wl$	$+0.0750 wl$
$a = 0.4l$	$+0.1359 wl$	$-0.1609 wl$	$-0.0250 wl$
$a = 0.5l$	$+0.0898 wl$	$-0.2148 wl$	$-0.1250 wl$
$a = 0.6l$	$+0.0544 wl$	$-0.2794 wl$	$-0.2250 wl$
$a = 0.7l$	$+0.0287 wl$	$-0.3537 wl$	$-0.3250 wl$
$a = 0.8l$	$+0.0119 wl$	$-0.4369 wl$	$-0.4250 wl$
$a = 0.9l$	$+0.0027 wl$	$-0.5277 wl$	$-0.5250 wl$
$a = l$	0	$-0.6250 wl$	$-0.6250 wl$

For Live Load

For Dead Load

From the influence diagram (Fig. 16), and the equation of the elastic curve (Eq. 2), we obtain the following values for the shears at any section distant $a = kl$ from the left end of a uniform continuous girder of two equal spans:

$$\text{Max. } V = wl \left(\frac{1}{16} - k + \frac{5}{8}k^2 - \frac{1}{16}k^4 \right) \quad (7)$$

$$\text{Min. } V = -wl \left(\frac{1}{16} + \frac{5}{8}k^2 - \frac{1}{16}k^4 \right) \quad (8)$$

$$\text{Total } V = wl \left(\frac{3}{8} - k \right) \quad (9)$$

These formulas yield the following values for the governing shears at the one-tenth points of the span (Table 2):

The shears due to uniform dead load are given by the formula or tabular values for Total V .

19. Two Equal Spans with Symmetrical Loading.—For symmetrical loading, a continuous girder of two equal spans is undeflected over the middle support, and each span is in a condition identical with that of a beam fixed at one end and simply supported at the other. The resulting reactions, stresses and deflections may be figured accordingly.

20. Two Unequal Spans.—For a continuous girder of two unequal spans (l , and $l_1 = nl$), the elastic curve is obtained in the same manner as Fig. 13 or Fig. 14, namely, by considering the girder held at two of the supports and deflected by a concentrated force applied at the remaining support. The resulting curve will be identical with the elastic curve of a beam of span $l + l_1$ deflected by a concentration at a distance l from one end.

The ordinates of the elastic curve for the intermediate reaction B (corresponding to Fig. 13) will be (for any point, $x = kl$, in the span l)

$$y = \frac{k}{2n}(1 + 2n - k^2) \quad (10)$$

and (for any point $x = kl_1$ in the span l_1),

$$y = \frac{kn}{2}\left(1 + \frac{2}{n} - k^2\right) \quad (11)$$

Both formulas yield $y = 1$ over the intermediate support ($k = 1$).

The elastic curve for the intermediate reaction B may also be scaled from simple-beam deflection graphs, such as those published by Chas. A. Ellis in *Engineering Record*, Jan. 15, 1916 (see also volume in this series entitled "Structural Members and Connections").

The ordinates of the elastic curve for the end-reaction A (corresponding to Fig. 14) will be (for any point $x = kl$ in the span l),

$$y = 1 - k - \frac{k - k^3}{2n + 2} \quad (12)$$

and (for any point $x = kl_1$ in the span l_1),

$$y = -\frac{n^2}{2n + 2}(k - k^3) \quad (13)$$

At the end A , ($k = 0$), the first of these equations yields a reaction influence ordinate, $y = 1$; at the intermediate support B , ($k = 1$), both equa-

tions yield a reaction influence ordinate, $y = 0$; and, at the end C , ($k = 0$), the second equation yields a reaction influence ordinate, $y = 0$. The elastic curve is of the same form as Fig. 14, with positive ordinates in the first span and negative ordinates in the second. It may also be obtained from the intermediate reaction curve by scaling the ordinates from the secant $B-C$ as indicated in Fig. 13.

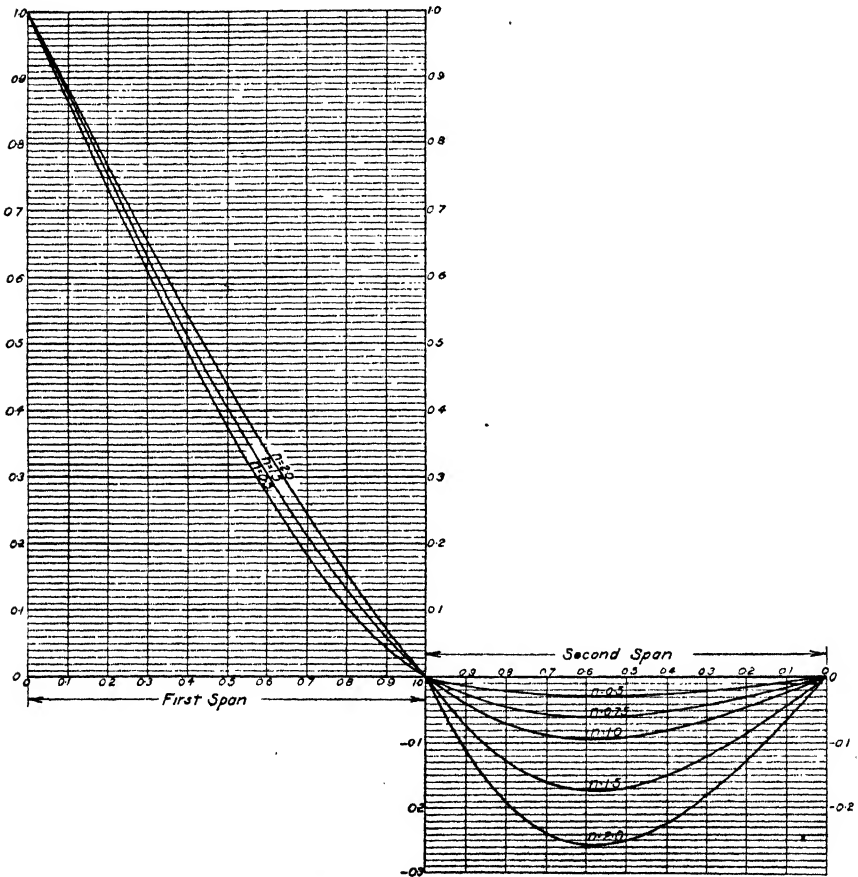

PLATE I.—Two-span continuous beam (Constant I). Elastic curve for end-reaction ($n =$ ratio of second span to first span).

The equations (10 to 13, inclusive) for two unequal spans reduce to the simpler equations (1 to 3, inclusive) for two equal spans, by simply substituting $n = 1$.

The ordinates of the elastic curve, for different values of n , are given in Plate I and Table 7.

21. Reactions for Two Continuous Spans.—For convenience of reference, the following table (Table 3) is inserted, giving the values of the three reactions of a two-span continuous girder for various cases of loading. The values expressed in Table 3 are obtained from the equations of the elastic curves derived above (Eqs. 1 to 3, 10 to 13).

TABLE 3.—REACTIONS FOR TWO CONTINUOUS SPANS (ASSUMING $I = \text{CONSTANT}$)

Condition of Loading R_A R_B R_C	Reactions		
	$l_1 = n l$ R_A	R_B	$a = k l$ R_C
	$(1 - k - \frac{k-k^3}{2n+2})P$	$\frac{k}{2n} (1+2n - k^2)P$	$-\frac{k-k^3}{2n(1+n)}P$
	$\frac{1}{4}(4-5k+k^3)P$	$\frac{k}{2}(3-k^2)P$	$-\frac{k}{4}(1-k^2)P$
	$\frac{1}{2}(2-3k+k^3)P$	$k(3-k^2)P$	Same as R_A
	$\frac{k^2}{2}(3-k)P$	$(2-3k^2+k^3)P$	Same as R_A
	$\left\{1 - \frac{k}{2} - \frac{k(2-k^2)}{8(1+n)}\right\}W$	$\frac{k}{2}(1 + \frac{2-k^2}{4n})W$	$-\frac{k(2-k^2)}{8n(1+n)}W$
	$\frac{k}{2}\left\{1 - \frac{4-4k+k^2}{4(1+n)}\right\}W$	$\left\{1 - \frac{k}{2} + \frac{k(4-4k+k^2)}{8n}\right\}W$	$-\frac{k(4-4k+k^2)}{8n(1+n)}W$
	$\frac{1}{16}(16-10k+k^3)W$	$\frac{k}{8}(6-k^2)W$	$-\frac{k}{16}(2-k^2)W$
	$\frac{k}{16}(4+4k-k^2)W$	$\frac{1}{8}(8-4k^2+k^3)W$	$-\frac{k}{16}(4-4k+k^2)W$
	$\left\{\frac{1}{2} - \frac{1}{8(1+n)}\right\}W$	$\left(\frac{1}{2} + \frac{1}{8n}\right)W$	$-\frac{1}{8n(1+n)}W$
	$\frac{7}{16}W$	$\frac{5}{8}W$	$-\frac{1}{16}W$
	$\frac{w l}{8}(3+n-n^2)$	$\frac{w l}{2}(1+n + \frac{1+n^3}{4n})$	$\frac{w l}{8}(1 - \frac{1}{n} + 3n)$
	$\frac{3}{8}w l$	$\frac{5}{4}w l$	$\frac{3}{8}w l$

22. Moments and Shears for Two Unequal Spans.—For a continuous beam of two unequal spans, the moment and shear influence diagrams are constructed upon the elastic curve as a foundation in the same manner as for two equal spans (Figs. 15 and 16).

Except for the sections near the intermediate support (between the "fixed point" and the support), the first span must be fully loaded for maximum positive bending moment, and the second span must be fully loaded for maximum negative bending moment. The resulting

values at a section distant a from the left end (for a uniform load w) will be,

$$\text{Max. } M = wa \left[\frac{l-a}{2} - \frac{l}{8(1+n)} \right] \quad (14)$$

$$\text{Min. } M = -wa \cdot \frac{n^3 l}{8(1+n)} \quad (15)$$

$$\text{Total } M = wa \left[\frac{l}{8}(3+n-n^2) - \frac{a}{2} \right] \quad (16)$$

These formulas reduce to the simpler ones, Eqs. (4) to (6), when $n = 1$.

For maximum and minimum shears at any section, distant $a = kl$ from the left end, the load must be placed as indicated in the shear influence diagram, Fig. 16. The resulting values (for a uniform load w) will be:

$$\text{Max. } V = (1-k)^2 \left[4 - \frac{(1+k)^2}{(1+n)} \right] \frac{wl}{8} \quad (17)$$

$$\text{Min. } V = - (6k^2 + 4nk^2 + n^3 - k^4) \frac{wl}{8(1+n)} \quad (18)$$

$$\text{Total } V = (3+n-n^2-8k) \frac{wl}{8} \quad (19)$$

These formulas reduce to the simpler ones, Eqs. (7) to (9), when $n = 1$.

23. Elastic Curve for Variable I .—For preliminary or approximate designs, it is sufficiently accurate to apply the formulas and values given in the preceding pages, based on the assumption of a constant moment of inertia. For final, exact designs, it is desirable to take into account the variation in moment of inertia.

The elastic curve will differ somewhat from the elastic curve for constant I . It may be constructed as follows:

First, tabulate or plot the bending moments M produced in the beam ABC (supported at B and C) by a unit force applied at A (Fig. 17a).

Second, tabulate or plot the resulting values of $M \div I$ throughout the beam ABC (Fig. 17b).

Third, consider the beam ABC as fixed at A and hinged at B and C , and loaded throughout its length with the "elastic weights," $M \div I$; the resulting bending moment curve (Fig. 17c) is the desired elastic curve.

The moment curve, Fig. 17c, may be obtained graphically, as the funicular polygon for the $\frac{M}{I}$ loading; or analytically, by tabular summation of shears. (The equation of the curve may also be found by calculus if the value of I can be expressed as a function of x .)

After the elastic curve, Fig. 17c, is obtained by any of the foregoing methods, its ordinates must be scaled down so that the end-ordinate at A equals unity. The ordinates at B and C are zero.

If the beam under elastic loading, Fig. 17*b*, is regarded as a simple span supported at *A* and *C*, the resulting bending moment diagram will be the elastic curve for the intermediate reaction *B*, similar to Fig. 13. The ordinates of this curve, measured from the chord *B-C*, will also give the elastic curve for the end-reaction *A*, similar to Fig. 17*c*.

It should be noted that in all constructions and applications of elastic curves, ratios and not absolute values are required. The ordinate over the reaction under consideration is always called unity, and the other ordinates are scaled down accordingly.

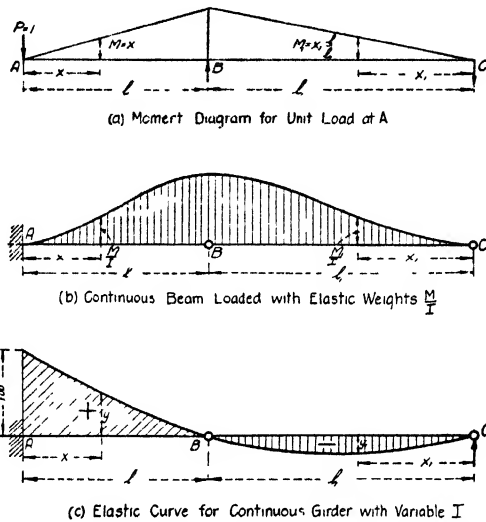

FIG. 17.—Construction of elastic curve for variable I .

24. Special Case—Triangular Variation of I .—A special case of variable I , recommended as a basis for preliminary or approximate design, is that of triangular variation, assuming the moment of inertia to vary as the ordinates of a triangle from zero at the ends to a maximum over the intermediate support. This assumption generally represents the actual variation of I in a two-span continuous truss about as well as the assumption of constant I ; moreover it yields results of striking simplicity. The elastic curves are parabolas, and other convenient relations obtain.

Referring to Fig. 17*a*, it will be noted that, for this special case, M and I follow the same law of variation, so that $M \div I$ will be constant throughout. The curve of elastic loading, Fig. 17*b*, consequently reduces to a horizontal line; and the elastic curve, Fig. 17*c*, will be simply the moment curve under uniform loading, and consequently a parabolic curve.

The ordinates of the elastic curve for triangular variation of I will be, in the first and second spans, respectively,

$$y = \frac{1 + n - k}{1 + n}(1 - k) \tag{20}$$

and

$$y_1 = -\frac{n^2}{1 + n}(1 - k)k \tag{21}$$

where n is the span-ratio ($l_1 \div l$), and k is the position-ratio ($x \div l$, or $x_1 \div l_1$). The curve represented by Eqs. (20) and (21) is a parabola.

If the two spans are equal ($n = 1$), the foregoing equations reduce to

$$y = 1 - 3/2k + 1/2k^2 \tag{22}$$

and

$$y_1 = -1/2(k - k^2) \tag{23}$$

The elastic curve platted with these ordinates is shown in Fig. 18. This curve is the influence line for reactions at A .

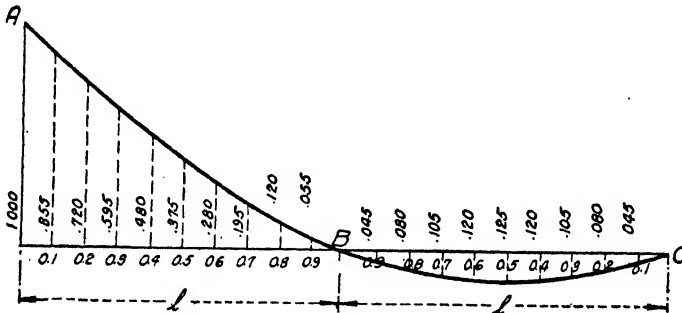

FIG. 18.—Elastic curve for triangular variation of I .

The elastic curve for reactions at B will be simply a parabola with unit ordinate at B (Fig. 19).

The intercepts measured from the chord $B-C$ in Fig. 19 (divided by 2.00) will give the elastic curve for reaction A (Fig. 18).

For a uniform load wl covering the first span, the reactions will be:

$$A = 5/12wl, \quad B = 2/3wl, \quad C = -1/12wl$$

For a uniform load $2wl$ covering both spans, the reactions will be:

$$A = 1/3wl, \quad B = 2/3wl, \quad C = 1/3wl$$

Upon the elastic curve, Fig. 18, the influence diagrams for moments and shears may be drawn exactly as in Figs. 15 and 16.

For all sections up to the "fixed point" ($k = 2/3$), the first span must be fully loaded for maximum positive bending moment, and the second

span must be fully loaded for maximum negative bending moment. The resulting values will be:

$$\text{Max. } M = wa\left(\frac{5}{12}l - \frac{a}{2}\right) \tag{24}$$

$$\text{Min. } M = -wa\left(\frac{1}{12}l\right) \tag{25}$$

$$\text{Total } M = wa\left(\frac{1}{3}l - \frac{a}{2}\right) \tag{26}$$

(Compare with Eqs. (4), (5) and (6)).

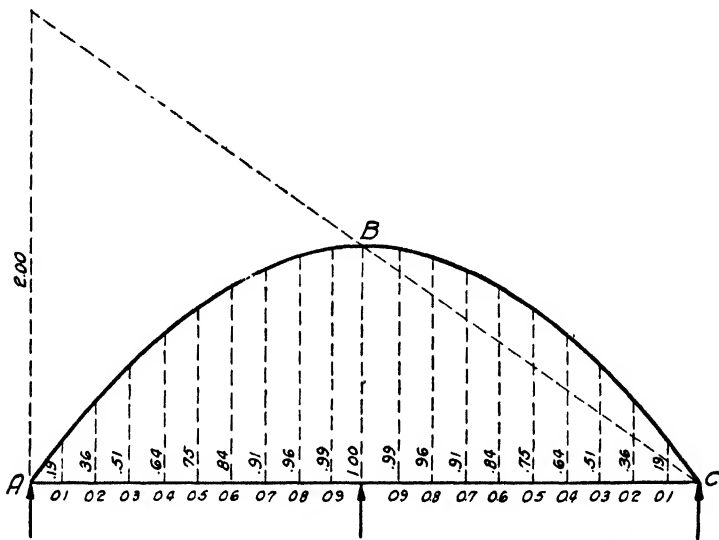

FIG. 19.—Elastic curve for middle reaction—Two equal spans with triangular variation of I .

The bending moment over the middle support B will always be negative, with a maximum value of Total $M_B = -\frac{1}{6}wl^2$.

For maximum positive shear at any section S (distant $a = kl$ from the end A), load the span-segment SB ; for maximum negative shear, load the segment AS and the span BC . The resulting values will be:

$$\text{Max. } V = wl\left(\frac{5}{12} - k + \frac{3}{4}k^2 - \frac{1}{6}k^3\right) \tag{27}$$

$$\text{Min. } V = -wl\left(\frac{1}{12} + \frac{3}{4}k^2 - \frac{1}{6}k^3\right) \tag{28}$$

$$\text{Total } V = wl\left(\frac{1}{3} - k\right) \tag{29}$$

(Compare with Eqs. (7), (8) and (9)).

For this special case of two equal spans with triangular variation of I , the general form (for variable I) of the well-known "Theorem of Three Moments" reduces to the following simple expression for the moment over the middle support:

$$M_B = -\frac{1}{2}\Sigma M, \tag{30}$$

where M is the simple-beam bending moment produced by each concentrated load (or element of uniform load) at its own point of application. Thus, for a single load P at the middle of either span, $M = \frac{Pl}{4}$ and, accordingly, $M_B = -\frac{Pl}{8}$; consequently the farther end-reaction will be $-\frac{P}{8}$, the nearer end-reaction will be $\frac{3}{8}P$, and the middle reaction will be $\frac{3}{4}P$. (Compare Figs. 18 and 19).

For application to uniform loads, Eq. (30) is more conveniently written:

$$M_B = -\frac{1}{l}(A_1 + A_2) \quad (31)$$

where A_1 is the area of the simple-beam moment diagram in one span, and A_2 is the area in the other span. Thus, load covering one span produces a parabolic moment diagram with maximum ordinate $\frac{1}{8}wl^2$ and area $A_1 = \frac{1}{12}wl^3$; Eq. (31) then yields $M_B = -\frac{1}{12}wl^2$, so that the farther end-reaction must be $-\frac{1}{12}wl$. Load covering both spans produces, Total $M_B = -\frac{1}{6}wl^2$.

If the spans are unequal, Eq. (31) must be written:

$$M_B = -\frac{2}{l+l_1}(A_1 + A_2) \quad (32)$$

Load covering span l produces $M_B = -\frac{wl^2}{6(1+n)}$.

In any case, when M_B is known, the end-reactions (A and C) are easily found by taking moments from each end about B ; and the intermediate reaction will be the total load minus $(A + C)$.

25. Elastic Curve for a Continuous Truss.—In the design of a continuous truss, approximate values of the chord sections may first be determined on the basis of a preliminary analysis, assuming either constant I or triangular variation of I (employing the corresponding elastic curve, Fig. 14 or Fig. 18). With the chord sections thus found, a more exact elastic curve may then be constructed as follows:

To construct the elastic curve for the reaction A (Fig. 20c), consider a unit load applied at A and proceed to find the deflections at the various panel points of the structure. This may be done graphically using a force polygon to get the stresses in the members and then combining the resulting strains in a Williot displacement diagram to obtain the deflections. The graph of these deflections, scaled down to a unit ordinate at A , is the desired elastic curve (Fig. 20c).

Instead of employing the Williot diagram to get the deflections, an analytical procedure proves more expeditious. For this purpose we apply the principle that the deflection curve for any structure is identical with the moment diagram obtained by applying the angle-changes w

as "elastic weights" at the respective panel points of the structure. (For a demonstration of this principle, see the writer's article, Elastic Curve Applied to the Design of the Sciotoville Bridge: *Engineering Record*, Aug. 28, 1915).

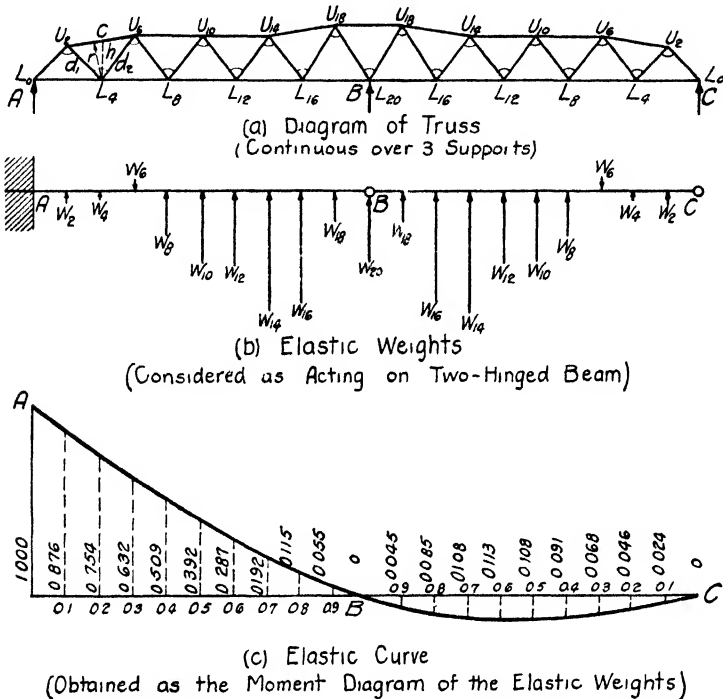

FIG. 20.—Construction of elastic curve for Sciotoville Bridge.

If the contribution of the web-stresses to the deflections is neglected the angle-changes w (measured in radians) are very simply figured by the formula:

$$w = \frac{\Delta c}{r} \tag{33}$$

where Δc is the elongation (or compression) in each chord member, due to unit A , and r is the lever-arm of the member about its center of moments (Fig. 20a).

For greater precision (in the final design), the effect of the web members (in a Warren system) is included by using the formula:

$$w = \pm \frac{(\Delta'c - \Delta'd_1 - \Delta'd_2)}{h} \tag{34}$$

where $\Delta'c$ is the elongation of the chord member multiplied by the secant of its inclination to the horizontal, $\Delta'd_1$ and $\Delta'd_2$ are the elongations of

the two web members multiplied by the secants of their respective inclinations to the horizontal, and h is the vertical altitude of the triangle formed by c , d_1 , and d_2 (Fig. 20a). In this formula, the plus sign is used for angle-changes at the upper panel points, and the minus sign for angle-changes at the lower panel points; elongations are taken as positive and compressions as negative. (For a demonstration of Eq. (34), see the writer's article, Truss Deflections Accurately Determined by Angle-changes and Elastic Weights: *Engineering Record*, May 13 and 20, 1916. The "elastic weight" w given by this formula represents, for each panel point, the angle-change between the two web members plus a correction for the line-changes in these two web members.)

The values thus found for the angle-changes w between the two web members meeting at each panel point are then treated as "elastic weights" applied at the respective panel points. In order to get zero moments at B and C , the beam $A-C$ (with reactions at A and C) is considered hinged at B and at C but anchored at A (Fig. 20b). The moment diagram is found either by calculation of moments or by construction as a funicular polygon for the "weights" w . The ordinates of the resulting polygon are then all reduced in a uniform ratio to make the initial ordinate scale unity. We then have the elastic curve of the structure, or influence line for the end-reaction A (Fig. 20c). The curve shows that the reaction A changes sign as the load passes the middle pier.

26. Example—Application of Method to Sciotoville Bridge.—In order to illustrate the actual simplicity of the above-described method of design, the complete work for determining the elastic curve for the Sciotoville Bridge (Fig. 20) is given in the following two tables (Tables 4 and 5). Since ratios, not absolute values, are required, the labor is minimized by calling the length of a panel unity, $E = 1$, etc.

In Table 4, the bending moments M produced by a unit load at A are simply the distances (in panels) to the respective centers of moments. Dividing the value of M by the corresponding lever arm r , we obtain the resulting stress S in each member. Multiplying this stress S by the length l , and dividing by the gross section of the member, we obtain the resulting elongation. Multiplying each elongation (Δl) by the secant of the inclination of the member to the horizontal, we obtain the terms $\Delta' l$ for the numerator of Eq. (34); grouping these terms in threes for each panel triangle, and dividing by the altitude h of that triangle, we obtain the desired elastic weight w for each panel point.

In Table 5, the bending moments are determined for a two-hinged beam loaded with the elastic weights w (Fig. 20b). A method of summations is used as the most expeditious method of figuring the moments. In this method, after figuring the simple-beam reaction (-502.4) at the free end C , all the shears are obtained therefrom by successive addition of the panel loads, and the moments are then obtained by successive

TABLE 4.—CALCULATION OF ELASTIC WEIGHTS (SCIOTOVILLE BRIDGE)

Panel point	Member	(1) Bending moment M	(2) Lever arm r	(3) Stress for A_1-1 S (1.2)	(4) Length l	(5) Gross section	(6) Elongation $\frac{1000\Delta l}{S \times 4 \div 5}$	(7) Secant	(8) Product Δl (6 x 7)	(9) Altitude h	(10) Elastic weight W (8 ÷ 9)
U ₂	L ₀ -U ₂	1	0.71	+1.41	1.41	361	56	1.41	+79	1	-36
	L ₀ -L ₄	1	1.00	-1.00	2	315	63	1.	-63		
L ₄	U ₂ -L ₄	-5	4.95	-1.01	1.41	189	75	1.41	-106		
	U ₂ -U ₆	2	1.15	+1.74	2.03	361	98	1.01	+99		
U ₆	L ₄ -U ₆	-3	5.60	+0.89	1.67	138	108	1.67	+180		
	L ₄ -L ₈	3	1.33	-2.25	2	474	95	1.	-95		
L ₈	U ₆ -L ₈	---	---	-1.25	1.67	105	199	1.67	-332		
	U ₆ -U ₁₀	4	1.33	+3.00	2	413	145	1	+145		
U ₁₀	L ₈ -U ₁₀	---	---	+1.25	1.67	121	173	1.67	+288		
	L ₈ -L ₁₂	5	1.33	-3.75	2	374	158	1.	-158		
L ₁₂	U ₁₀ -L ₁₂	---	---	-1.25	1.67	238	88.	1.67	-146		
	U ₁₀ -U ₁₄	6	1.33	+4.50	2	317	284	1.	+284		
U ₁₄	L ₁₂ -U ₁₄	---	---	+1.25	1.67	278	75	1.67	+125		
	L ₁₂ -L ₁₆	7	1.33	-5.25	2	77?	389	1.	-389		
L ₁₆	U ₁₄ -L ₁₆	-1	7.20	-0.14	1.67	391	6	1.67	-10		
	U ₁₄ -U ₁₈	8	1.48	+5.40	2.03	208	526	1.01	+534		
J ₁₈	L ₁₆ -U ₁₈	-1	7.71	+0.13	1.94	381	7	1.94	+13		
	L ₁₆ -L ₂₀	9	1.67	-5.40	2	479	226	1.	-226		
L ₂₀	U ₁₈ -L ₂₀	---	---	-1.17	1.94	499	45	1.94	-88		
	U ₁₈ -U ₂₀	10	1.67	+6.00	1	596	101	1.	+101		

TABLE 5.—CALCULATION OF ELASTIC CURVE (SCIOTOVILLE BRIDGE)

Panel point	Elastic weight (W)	Shear	Moment	Ordinate
C 0	0		0	0
2	- 36	- 502.4	- 502.4	- 0.024
4	- 22	- 166.4	- 968.8	- 0.046
6	+ 43	- 444.4	- 1413.2	- 0.068
8	- 142	- 487.4	- 1900.6	- 0.091
10	- 225	- 345.4	- 2246.0	- 0.108
12	- 229	- 120.4	- 2366.4	- 0.113
14	- 378	108.6	- 2257.8	- 0.108
16	- 354	486.6	- 1771.2	- 0.085
18	- 90	840.6	- 930.6	- 0.045
B 20	- 227	930.6	0	0
18	- 90	1157.6	1157.6	0.055
16	- 354	1247.6	2405.2	0.115
14	- 378	1601.6	4006.8	0.192
12	- 229	1979.6	5986.4	0.287
10	- 225	2208.6	8195.0	0.392
8	- 142	2433.6	10628.6	0.509
6	+ 43	2575.6	13204.2	0.632
4	- 22	2532.6	15736.8	0.754
2	- 36	2554.6	18291.4	0.876
A 0	0	2590.6	20882.0	1.000

summation of the shears. Ordinarily, the results would have to be multiplied by the panel length to give the true moments, but in the present case this factor is unity and the operation otherwise unnecessary (since only ratios are required). Dividing all of the moments by the value at *A* (in order to make the initial ordinate unity), we obtain the ordinates of the elastic curve (Fig. 20*c*).

The final results, in the last column, afford an excellent check upon all the computations in Table 5, in the fact that the ordinates taken in pairs for corresponding panel points of the two spans give arithmetical sums of exactly 1.0, 0.9, 0.8, and so on to 0.0. This necessary relation arises from the fact that the ordinates of the elastic curve (Fig. 20*c*), measured from the chord *A-C*, are symmetrical about the center line; so that the vertical intercepts between the segment *A-B* of the elastic curve and its chord must be identical with the corresponding intercepts of the segment *B-C*.

The entire work of figuring the elastic curve by the foregoing method, as illustrated in Tables 4 and 5, is a matter of only 2 or 3 hr. at the most. After the elastic curve (Fig. 20*c*) is determined, the remainder of the design is essentially the same as for a simple structure.

27. Comparison of Elastic Curves for Different Assumptions.—The exact method outlined above (developed by the writer for the design of the Sciotoville Bridge) is the one to be used for the final computation of important structures. For less important or preliminary designs, simpler approximate methods may be used.

In the case of the Sciotoville Bridge, three successive designs were made: (1) Preliminary design (approximate); the truss was treated as a beam with constant moment of inertia. (2) The above-outlined method was used, but with the influence of the web members neglected, employing Eq. (33). (3) Final design (exact); the effect of all the members was included, employing Eq. (34) as shown in Tables 4 and 5.

For the first approximation (assuming $I = \text{constant}$), the ordinates of the elastic curve (Fig. 14) are given directly by the general Eq. (2). The sections obtained in this approximation are used as a basis for the succeeding designs. The elastic ordinates for the three assumptions, also for the assumption of triangular variation of I (Eq. 22, Fig. 18), are compared in Table 6.

The ordinates for only one-half of the elastic curve are listed in Table 6, as those for the other span are quickly obtainable by the check method explained above, *i.e.*, by subtracting the given ordinates of the curve from those of the chord *A-B*. The above table is useful, inasmuch as its values can be adopted for the preliminary designs of other structures, thereby saving considerable time and labor. For a structure similar in general outline to the Sciotoville Bridge, the values in column (3) should be used. For girders and trusses with parallel chords, the values in column (1) would be a closer approximation.

TABLE 6.—COMPARISON OF ELASTIC CURVES (SCIOTOVILLE BRIDGE)

Panel point	$\frac{x}{l}$	(1) Assumption $I = \text{Constant}$	(2) Web members neglected	(3) All members included	(4) Assumption triangular variation of I
A 0	0	1.000	1.000	1.000	1.000
2	0.1	0.875	0.871	0.876	0.855
4	0.2	0.752	0.744	0.754	0.720
6	0.3	0.632	0.623	0.632	0.595
8	0.4	0.516	0.505	0.509	0.480
10	0.5	0.406	0.393	0.392	0.375
12	0.6	0.304	0.287	0.287	0.280
14	0.7	0.211	0.193	0.192	0.195
16	0.8	0.128	0.114	0.115	0.120
18	0.9	0.057	0.053	0.055	0.055
B 20	1.0	0	0	0	0
Area AB		4.381	4.283	4.312	4.175
Area BC		0.619	0.717	0.688	0.825
Sum of Areas		5.000	5.000	5.000	5.000

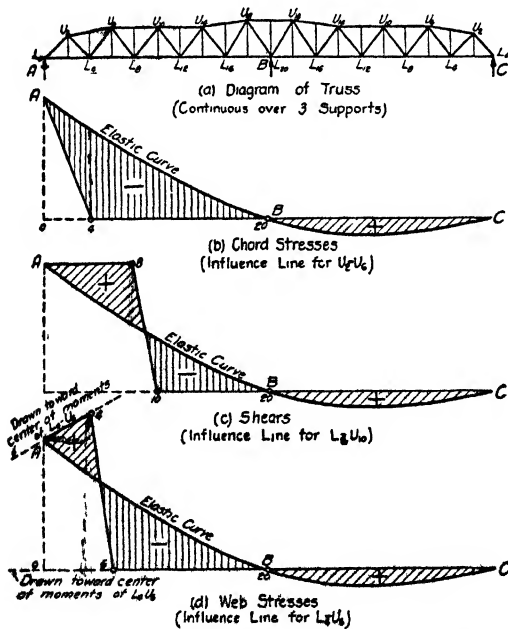

FIG. 21.—Influence diagrams for Sciotoville Bridge.

A comparison of the areas of the three elastic curves, as given in Table 6, indicates that the results of the first assumption may be in error by +2 to -10 per cent, and those of the second approximation by -1 to +4 per cent. In lateral systems, where the web members have relatively small sections, the error of neglecting these members may be much greater; on the other hand, the great uncertainty of lateral forces does not warrant a refined calculation of lateral stresses. For important structures, however, the writer recommends the use of the exact method (3), as the greater reliability of the results is easily worth the slight additional work required.

28. Influence Diagrams for Continuous Trusses.—After the elastic curve (Fig. 20c) is platted to any convenient scale, the influence lines for all the members of the truss are simply constructed by drawing straight lines across the curve, as illustrated in Fig. 21. A single plating of the curve is therefore sufficient for the entire design. The various influence lines are drawn and used in the same manner as for a simple truss, with the single difference that the elastic curve replaces the straight line *A-B* which would ordinarily represent the influence line for the end-reaction.

29. Determination of Live Load Stresses.—The above-described influence diagrams can be applied to the determination of maximum live load stresses by the customary procedure of trying different positions of the specified train-loading, and comparing the sums of the products obtained by multiplying the scaled ordinates by the respective wheel-loads. To facilitate and expedite this operation, the writer has invented two devices. The first is a double scale of wheel loads and spacings on a paper strip which is applied to the influence diagram to determine directly the critical load position. The second device (independently invented by O. H. Ammann and by the writer) is a tracing of wheel load scales which is superimposed on the influence diagram to give directly the products of ordinates by wheel loads. Both of these devices are described in an article by the writer, entitled *Two Time-savers for Use with Influence Lines: Engineering Record*, April 24, 1915.

In the design of the Sciotoville Bridge, a great economy of time and effort was effected by the use of equivalent uniform loads. These were given directly by a formula invented by the writer and published in an article *Equivalent Uniform Loads for Long Span Bridges: Engineering News*, Feb. 25, 1915. For shorter spans, the values may be taken directly from a chart, invented by the writer, giving the exact equivalent uniform load for any point of any span. (Chart of equivalent uniform loads for railway bridges: *Engineering News*, April 22, 1915; "American Civil Engineer's Handbook," p. 853, 1920; "Lefax," No. 10-348, September 1920; *Proceedings Amer. Soc. C. E.*, May, 1922.) The uniform load value given by formula or chart is simply multiplied by the corresponding

influence area, to give the maximum stress in any member of the structure. For extreme precision, a correction may be made for the curvature of the influence lines, as described in the writer's article, Equivalent Uniform Loads for Indeterminate Structures: *Engineering News-Record*, Aug. 1, 1918; but this correction will rarely exceed 1 to 2 per cent.

30. Determination of Dead Load Stresses.—For dead load stresses, all the panel dead loads are multiplied by the respective ordinates of the elastic curve, and the algebraic sum of the products constitutes the end-reaction. This determined, the stresses are figured exactly as in a simple truss, using the method of summations for shears and moments.

After the details for all connections are worked out, a final adjustment of sections is made for the actual dead load weights determined from the detail drawings. On the close agreement of these actual weights and sections with the values initially assumed depends, to a great extent, the efficient solution of the design. In the case of the Sciotoville Bridge, a calculation of the weight from the final shop drawings showed the assumed weight to be 3 per cent in excess and, therefore, no re-design was made.

31. Bridges Continuous over Three Spans.—The three-span bridge merits detailed consideration, as it will be a common type. Where a crossing requires a larger number of spans, it will generally be found desirable to interrupt the continuity at every third pier.

The first step in the analysis of a three-span continuous bridge is the construction of the elastic curves, or influence lines, for the reactions.

32. Elastic Curves for Three-span Continuous Bridge.—In general, the influence line for the reaction at any support of a continuous bridge is simply the elastic curve produced by removing that support and applying a concentrated load to give the point a unit vertical displacement (see the writer's article, Influence Lines as Deflection Diagrams: *Engineering Record*, Nov. 25, 1916).

In the case of a three-span continuous bridge, the elastic curve is best obtained by the synthesis of two simpler deflection diagrams. Thus, let it be required to construct the influence diagram for intermediate reactions in a three-span girder or truss, $AMNB$, Fig. 22.

First consider both supports M and N removed, and a unit load applied at M ; the resulting elastic curve (drawn to any convenient scale) is $APXB$. Next, to restore X to its original position, a reaction is evoked at N . A force at this point would produce an elastic curve $AQXB$ shown in dotted lines; this curve is reduced in scale so as to have the same ordinate as the first curve at X . The differences between the ordinates of the two curves give the ordinates of the desired influence line or elastic curve, $ARNB$. This is platted to a scale making the ordinate at R equal to unity.

It may be noted from the influence line in Fig. 22 that any loads in the contiguous spans will give positive contributions to the reaction R , and any loads in the non-contiguous span will give negative contributions.

The elastic curve for the end-reaction may be constructed in a similar manner as shown in Fig. 23a.

In this case, the supports A and N are considered removed. A load applied at A produces the deflection curve $PMXB$ (drawn to any scale). A load applied at N produces the deflection curve $QMXB$ (drawn to any scale).

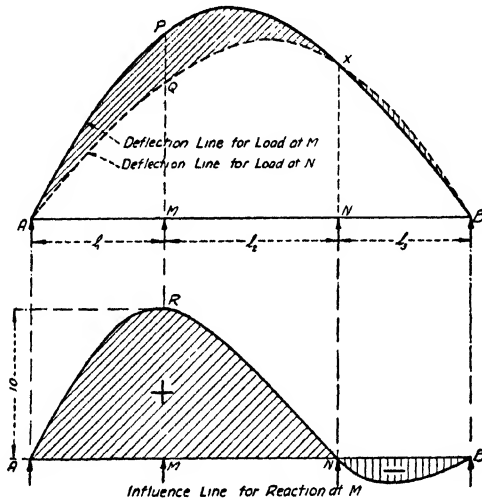

Fig. 22.—Three-span continuous girder. Construction of elastic curve for intermediate reaction.

reduced scale so as to have the same ordinate as the first curve at X). The intercepts between the two curves give the ordinates of the desired elastic curve $RMNB$ (drawn to scale giving unit end-ordinate). It may be noted from this influence line (Fig. 23a) that any loads in the end spans give positive contributions to the reaction R , and any loads in the middle span give negative contributions.

When the spans are symmetrical, it will be simpler to use the construction shown in Fig. 23b. In this case, the end supports A and B are considered removed. A load applied at A produces the deflection curve $PMNQ$ (drawn to any scale). A load applied at B produces the similar deflection curve $TNMS$ (drawn to any scale). After multiplying the ordinates of either curve by a constant factor to make BT equal to BQ , the differences between corresponding ordinates of the two curves will give the ordinates of the desired elastic curve $RMNB$ (drawn to a scale giving unit end-ordinate).

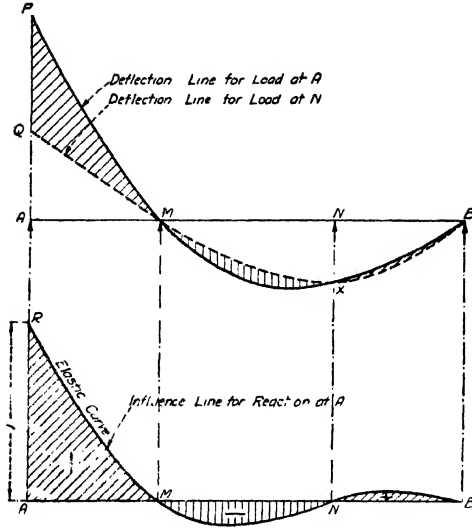

FIG. 23a.—Three-span continuous girder. Construction of elastic curve for end reaction. (First method).

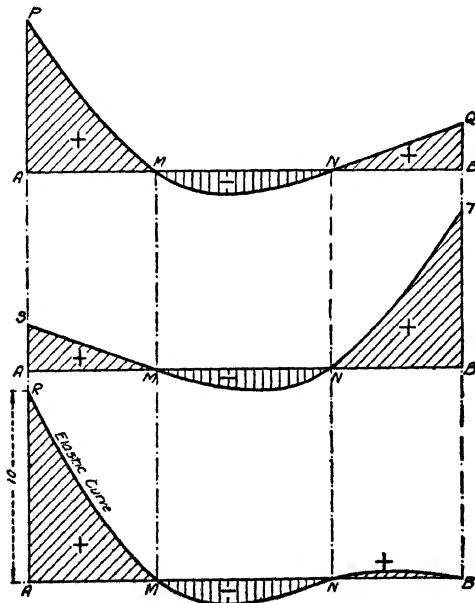

FIG. 23b.—Three-span continuous girder. Construction of elastic curve for end reaction. (Second method).

The component curves in Figs. 22, 23a, and 23b, are identical with the elastic curves of two-span continuous girders, and may be calculated or platted by the methods described in the preceding pages. If the moment of inertia, I , is assumed constant, each component curve of Fig. 22 is obtained by regarding the girder as a two-span beam and applying Eqs. (10) and (11); the same equations also give the component curve $QMXB$ of Fig. 23a (the portion QM being a tangent); and the other component curves of Figs. 23a and 23b are given by Eqs. (12) and (13). In Fig. 23b the portions NQ and MS are tangents.

The resultant curves, as well as the component curves, in Figs. 22 and 23 may also be obtained approximately by the mechanical method of bending splines under the described conditions of support and loading.

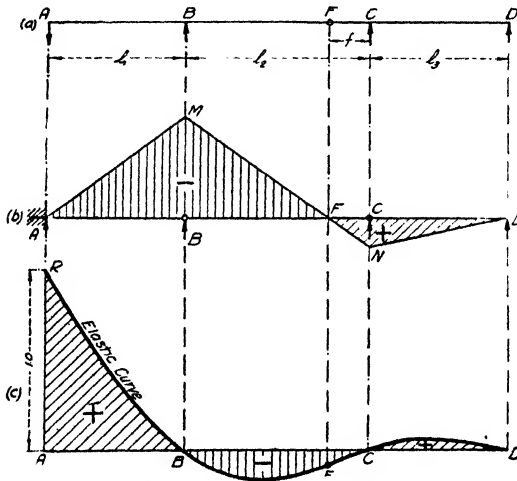

FIG. 24.—Three-span continuous girder with constant I . Construction of elastic curve for end reaction. (Using fixed point F).

A simple, direct method of constructing the elastic curve for a three-span continuous girder (with constant I) is illustrated in Fig. 24. In this method we make use of a "fixed point" F in the middle span. The distance of F from the support C is given by

$$f = \frac{l_2}{3 + 2 \frac{l_3}{l_2}} \tag{35}$$

(See Art. 38 on "Fixed Points in Continuous Spans." Compare Eq. (47).)

When the end support A is removed and a concentrated load substituted (Fig. 24a), the resulting moment diagram will be as shown in Fig. 24b. (Absolute values are not required.) The diagram passes through F , since F is a point of contraflexure (or zero bending moment) for any load

to the left of *B*. Treating the area of this moment diagram (Fig. 24*b*) as a loading diagram, the resulting funicular polygon or moment diagram Fig. 24*c* will be the desired deflection diagram or elastic curve. The end ordinate is called unity.

33. Symmetrical Three-span Continuous Girders.—The common case of three-span continuous bridges is that of equal end-spans. For this case, if *I* is constant, the equations of the elastic curve for the end

TABLE 7.—ORDINATES OF ELASTIC CURVE FOR END REACTION, TWO UNEQUAL SPANS (*I* = CONSTANT) (*n* = RATIO OF SECOND SPAN TO FIRST SPAN)

<i>k</i>	<i>n</i> = 0.5	<i>n</i> = 0.6	<i>n</i> = 0.67	<i>n</i> = 0.75	<i>n</i> = 0.8	<i>n</i> = 1.0	<i>n</i> = 1.5	<i>n</i> = 2.0
0	1.000	1.000	1.000	1.000	1.000	1.000	1.000	1.000
0.1	0.867	0.869	0.870	0.872	0.873	0.875	0.880	0.884
0.2	0.736	0.740	0.743	0.745	0.747	0.752	0.762	0.768
0.3	0.609	0.615	0.616	0.622	0.624	0.632	0.645	0.654
0.4	0.488	0.495	0.500	0.504	0.507	0.516	0.533	0.544
0.5	0.375	0.383	0.388	0.393	0.396	0.406	0.425	0.438
0.6	0.272	0.280	0.285	0.290	0.293	0.304	0.323	0.336
0.7	0.181	0.188	0.193	0.198	0.201	0.211	0.229	0.241
0.8	0.104	0.110	0.114	0.118	0.120	0.128	0.142	0.152
0.9	0.043	0.046	0.049	0.051	0.052	0.057	0.066	0.072
1.0	0	0	0	0	0	0	0	0
Area	0.417	0.422	0.425	0.429	0.431	0.438	0.450	0.458
1.0	0	0	0	0	0	0	0	0
0.9	-0.014	-0.019	-0.023	-0.028	-0.030	-0.043	-0.077	-0.114
0.8	-0.024	-0.032	-0.038	-0.046	-0.051	-0.072	-0.130	-0.192
0.7	-0.030	-0.040	-0.048	-0.057	-0.063	-0.089	-0.160	-0.238
0.6	-0.032	-0.043	-0.051	-0.062	-0.068	-0.096	-0.173	-0.256
0.5	-0.031	-0.042	-0.050	-0.060	-0.067	-0.094	-0.169	-0.250
0.4	-0.028	-0.038	-0.045	-0.054	-0.060	-0.084	-0.151	-0.224
0.3	-0.023	-0.031	-0.036	-0.044	-0.048	-0.068	-0.123	-0.182
0.2	-0.016	-0.022	-0.026	-0.031	-0.034	-0.048	-0.086	-0.128
0.1	-0.008	-0.011	-0.013	-0.016	-0.018	-0.025	-0.045	-0.066
0	0	0	0	0	0	0	0	0
Area	-0.021	-0.028	-0.033	-0.040	-0.044	-0.063	-0.113	-0.167

reaction (Figs. 23*a*, 23*b*, 24) will be (in the first, second and third spans, respectively)

$$y = 1 - k - \frac{2 + 2n}{m}(k - k^3) \tag{36}$$

$$y = -\frac{n^2}{m}[(2 + 2n)(2k - 3k^2 + k^3) - n(k - k^3)] \tag{37}$$

$$y = \frac{n}{m}(k - k^3)$$

Where

$$n = \text{the length-ratio of middle span to end span} = \frac{l_1}{l}$$

$$k = \text{the position-ratio in any span} = \frac{x}{l} \text{ or } \frac{x_1}{l_1}$$

$$m = (2 + n)(2 + 3n) = 4 + 8n + 3n^2 \tag{39}$$

The elastic curve (Fig. 24*c*) may be platted directly from these Eqs. (36) to (38).

The ordinates of the resulting elastic curve (or influence ordinates for *R*₁), for different ratios of middle-span to end-spans, are given in Plate II

and Table 8A. The areas of the elastic curve for each span, obtained by summation, are also given in the table, and can be used for figuring the effects of full-span loads.

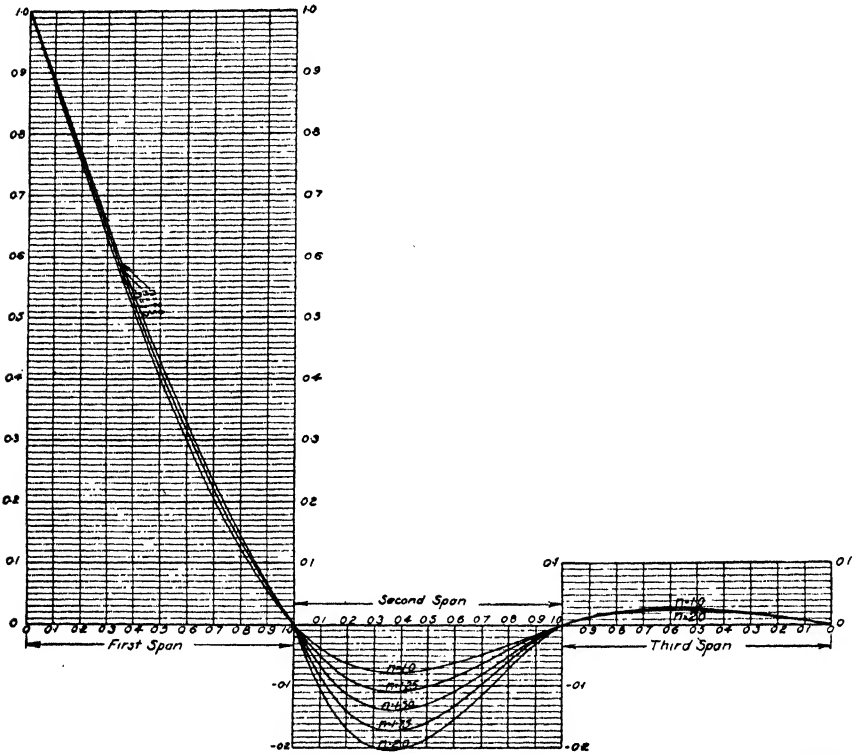

PLATE II.—Three-span continuous beam. (Symmetrical spans, constant I). Elastic curve for end-reaction. (n = ratio of middle span to end spans).

For the same case of symmetrical span with constant I , the equations of the elastic curve for the second reaction (Fig. 22) will be (in the first, second, and third spans, respectively)

$$y = k + \frac{(1 + 2n)}{n(2 + 3n)}(k - k^3) \tag{40}$$

$$y = 1 - k + \frac{n}{m}[(2n + 2n^2)(2k - 3k^2 + k^3) - n^2(k - k^3) + (2 + 3n)(k - 3k^2 + 2k^3)] \tag{41}$$

$$y = -\frac{1 + n}{n(2 + 3n)}(k - k^3) \tag{42}$$

The elastic curve (Fig. 22) may be platted directly from these Eqs. (40) to (42).

The ordinates of the resulting elastic curve (or influence ordinates for R_2), for various ratios of middle-span to end-spans, are given in Plate III and Table 8B. The areas of the elastic curve for each span, obtained by summation, are also given in the table, and can be used for figuring the effects of full-span loads.

TABLE 8A.—ORDINATES OF ELASTIC CURVE FOR END REACTION, SYMMETRICAL THREE-SPAN CONTINUOUS GIRDER ($I = \text{CONSTANT}$) ($n = \text{RATIO OF MIDDLE SPAN TO END SPAN}$)

k	$n=1.0$	$n=1.25$	$n=1.33$	$n=1.5$	$n=1.75$	$n=2.0$
First Span	0	+ 1.000	+ 1.000	+ 1.000	+ 1.000	+ 1.000
	0.1	+ 0.874	+ 0.876	+ 0.877	+ 0.878	+ 0.880
	0.2	+ 0.749	+ 0.754	+ 0.755	+ 0.758	+ 0.761
	0.3	+ 0.627	+ 0.634	+ 0.636	+ 0.640	+ 0.644
	0.4	+ 0.511	+ 0.519	+ 0.522	+ 0.526	+ 0.531
	0.5	+ 0.400	+ 0.410	+ 0.412	+ 0.418	+ 0.423
	0.6	+ 0.298	+ 0.308	+ 0.310	+ 0.316	+ 0.321
	0.7	+ 0.205	+ 0.214	+ 0.217	+ 0.222	+ 0.227
	0.8	+ 0.124	+ 0.131	+ 0.133	+ 0.137	+ 0.141
	0.9	+ 0.054	+ 0.055	+ 0.060	+ 0.062	+ 0.065
	1.0	0	0	0	0	0
Area	+ 0.433	+ 0.440	+ 0.442	+ 0.445	+ 0.449	+ 0.453
Second Span	0	0	0	0	0	0
	0.1	- 0.037	- 0.054	- 0.059	- 0.070	- 0.086
	0.2	- 0.064	- 0.088	- 0.097	- 0.114	- 0.141
	0.3	- 0.077	- 0.106	- 0.116	- 0.136	- 0.168
	0.4	- 0.080	- 0.109	- 0.120	- 0.138	- 0.172
	0.5	- 0.075	- 0.102	- 0.111	- 0.130	- 0.159
	0.6	- 0.064	- 0.086	- 0.094	- 0.109	- 0.132
	0.7	- 0.049	- 0.065	- 0.071	- 0.082	- 0.098
	0.8	- 0.032	- 0.042	- 0.045	- 0.051	- 0.062
	0.9	- 0.015	- 0.019	- 0.021	- 0.024	- 0.027
	1.0	0	0	0	0	0
Area	- 0.250	- 0.268	- 0.274	- 0.286	- 0.306	- 0.325
Third Span	1.0	0	0	0	0	0
	0.9	+ 0.011	+ 0.011	+ 0.011	+ 0.011	+ 0.011
	0.8	+ 0.019	+ 0.019	+ 0.019	+ 0.019	+ 0.019
	0.7	+ 0.024	+ 0.024	+ 0.024	+ 0.024	+ 0.023
	0.6	+ 0.026	+ 0.026	+ 0.026	+ 0.025	+ 0.024
	0.5	+ 0.025	+ 0.025	+ 0.025	+ 0.025	+ 0.024
	0.4	+ 0.022	+ 0.022	+ 0.022	+ 0.022	+ 0.021
	0.3	+ 0.018	+ 0.018	+ 0.018	+ 0.018	+ 0.017
	0.2	+ 0.013	+ 0.013	+ 0.013	+ 0.013	+ 0.012
	0.1	+ 0.007	+ 0.007	+ 0.007	+ 0.006	+ 0.006
	0	0	0	0	0	0
Area	+ 0.017	+ 0.017	+ 0.017	+ 0.016	+ 0.016	+ 0.016

With the aid of the elastic curves defined by the foregoing Eqs. (36) to (42), inclusive, we may obtain the reactions for various conditions of loading. Expressions for these reactions are compiled in Table 9.

It will be noted that the function $(k - k^3)$ is of frequent occurrence in the formulas for continuous-span reactions; a simple tabulation of values of this function can be used to expedite continuous bridge computations. The same table will also give the function $(2k - 3k^2 + k^3)$, if $(1-k)$ is

used instead of k ; and the difference between these two functions for any value of k , will give $(k - 3k^2 + 2k^3)$ which is the only remaining function of (k) occurring in the reaction formulas (36) to (42) inclusive.

Instead of applying the formulas, the reactions may also be figured directly from the influence ordinates given in Tables 8A and 8B.

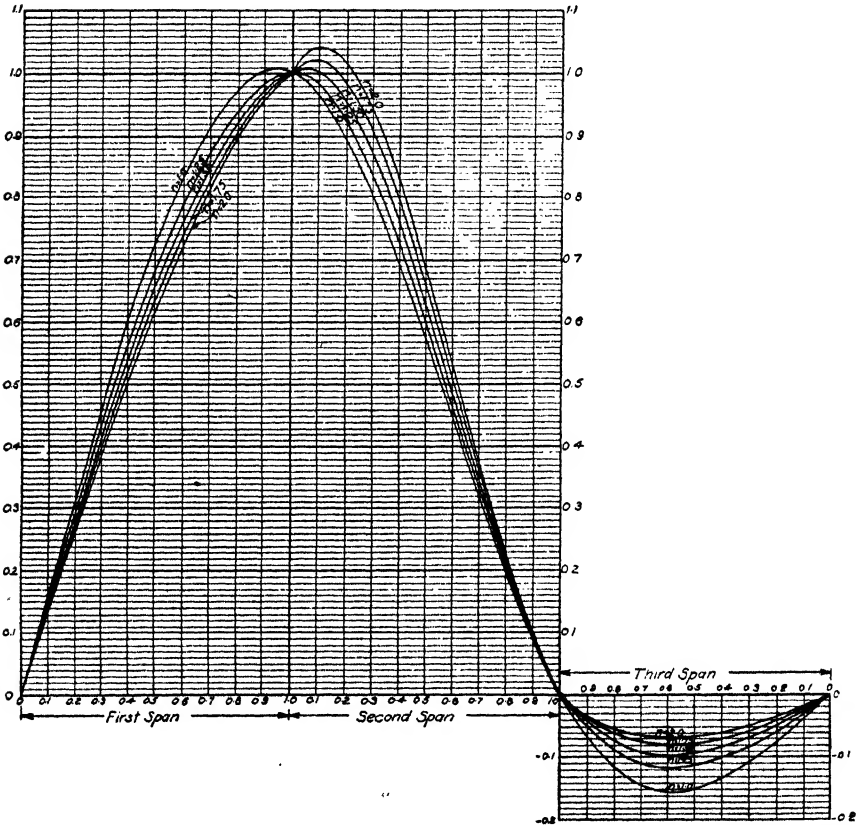

PLATE III.—Three-span continuous beam. (Symmetrical spans, constant I). Elastic curve for intermediate reaction. (n = ratio of middle span to end spans).

34. Influence Diagrams for Three-span Continuous Bridge.—For the end-spans, influence diagrams are constructed exactly as for two-span continuous bridges, namely, by drawing straight lines across the elastic curve, as illustrated in Figs. 15, 16 and 21. Typical influence diagrams for an end-span are shown in Fig. 25a. The diagram factor for the moment influence diagram, in Fig. 25a, is the reaction lever-arm a . The diagram factor for the shear influence diagram is unity.

The influence diagrams reverse in sign at each intermediate support, indicating that alternate spans must be loaded for maximum stress.

For the middle-span, the problem is not so simple, as the expression for each stress involves R_2 as well as R_1 . The usual method of treatment is to construct an independent (curved) influence line for each member, the ordinates of these influence lines being figured from the values of R_1 and R_2 given by the respective elastic curves.

TABLE 8B.—ORDINATES OF ELASTIC CURVE FOR INTERMEDIATE REACTION, SYMMETRICAL THREE-SPAN CONTINUOUS GIRDER ($I = \text{CONSTANT}$) ($n = \text{RATIO OF MIDDLE SPAN TO END SPAN}$)

k	$n=1.0$	$n=1.25$	$n=1.33$	$n=1.5$	$n=1.75$	$n=2.0$	
First Span	0	0	0	0	0	0	
	0.1	+ 0.159	+ 0.148	+ 0.145	+ 0.141	+ 0.135	+ 0.131
	0.2	+ 0.315	+ 0.293	+ 0.288	+ 0.279	+ 0.268	+ 0.260
	0.3	+ 0.464	+ 0.433	+ 0.425	+ 0.412	+ 0.397	+ 0.385
	0.4	+ 0.602	+ 0.563	+ 0.554	+ 0.538	+ 0.519	+ 0.505
	0.5	+ 0.725	+ 0.682	+ 0.672	+ 0.654	+ 0.633	+ 0.617
	0.6	+ 0.831	+ 0.787	+ 0.776	+ 0.758	+ 0.736	+ 0.720
	0.7	+ 0.914	+ 0.874	+ 0.864	+ 0.846	+ 0.827	+ 0.812
	0.8	+ 0.973	+ 0.933	+ 0.932	+ 0.918	+ 0.902	+ 0.890
	0.9	+ 1.003	+ 0.983	+ 0.978	+ 0.970	+ 0.961	+ 0.953
	1.0	+ 1.0	+ 1.0	+ 1.0	+ 1.0	+ 1.0	+ 1.0
Area	+ 0.650	+ 0.622	+ 0.615	+ 0.602	+ 0.589	+ 0.578	
Second Span	0	+ 1.0	+ 1.0	+ 1.0	+ 1.0	+ 1.0	
	0.1	+ 0.963	+ 0.982	+ 0.988	+ 1.001	+ 1.020	+ 1.040
	0.2	+ 0.896	+ 0.926	+ 0.935	+ 0.955	+ 0.986	+ 1.016
	0.3	+ 0.805	+ 0.838	+ 0.850	+ 0.872	+ 0.902	+ 0.942
	0.4	+ 0.696	+ 0.728	+ 0.738	+ 0.760	+ 0.795	+ 0.828
	0.5	+ 0.575	+ 0.602	+ 0.611	+ 0.630	+ 0.659	+ 0.688
	0.6	+ 0.448	+ 0.468	+ 0.475	+ 0.488	+ 0.510	+ 0.532
	0.7	+ 0.321	+ 0.333	+ 0.336	+ 0.346	+ 0.359	+ 0.373
	0.8	+ 0.200	+ 0.204	+ 0.206	+ 0.210	+ 0.218	+ 0.224
	0.9	+ 0.090	+ 0.092	+ 0.092	+ 0.094	+ 0.094	+ 0.095
	1.0	0	0	0	0	0	0
Area	+ 0.550	+ 0.568	+ 0.574	+ 0.586	+ 0.606	+ 0.625	
Third Span	1.0	0	0	0	0	0	
	0.9	- 0.068	- 0.054	- 0.050	- 0.044	- 0.037	- 0.032
	0.8	- 0.115	- 0.090	- 0.084	- 0.074	- 0.062	- 0.054
	0.7	- 0.143	- 0.112	- 0.104	- 0.092	- 0.077	- 0.067
	0.6	- 0.154	- 0.120	- 0.112	- 0.098	- 0.083	- 0.072
	0.5	- 0.150	- 0.117	- 0.109	- 0.096	- 0.081	- 0.070
	0.4	- 0.134	- 0.105	- 0.098	- 0.086	- 0.073	- 0.063
	0.3	- 0.109	- 0.086	- 0.080	- 0.070	- 0.059	- 0.051
	0.2	- 0.077	- 0.060	- 0.056	- 0.049	- 0.042	- 0.036
	0.1	- 0.040	- 0.031	- 0.029	- 0.025	- 0.022	- 0.019
	0	0	0	0	0	0	0
Area	- 0.100	- 0.078	- 0.073	- 0.064	- 0.054	- 0.047	

In order, however, to retain the advantage of employing the elastic curve as a foundation for all influence lines, and thereby to simplify the operation of finding maximum stresses, the writer has devised a method of "double influence lines" for treating the intermediate spans of bridges continuous over three or four spans.

35. The Method of Double Influence Lines.—This method is illustrated (for the middle span of a three-span bridge) in Fig. 25b.

The elastic curves for the first and second reactions are used as a foundation. The elastic curve $AEC D$ (reproduced from Fig. 22) is the influence line for R_2 ; and the elastic curve $FBC D$ (reproduced from Figs.

TABLE 9.—REACTIONS FOR SYMMETRICAL THREE-SPAN CONTINUOUS BRIDGE (ASSUMING CONSTANT I)

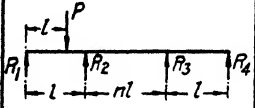
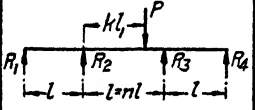
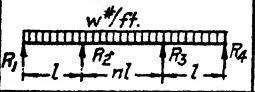
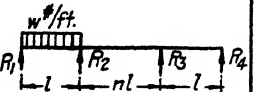
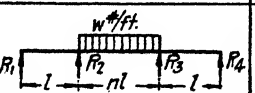
Loading	Reactions $m = 4 + 8n + 3n^2$
	$R_1 = P(1-k) - \frac{2+2n}{m} P(k-k^3)$ $R_2 = Pk + \frac{1+2n}{n(2+3n)} P(k-k^3)$ $R_3 = -\frac{1+n}{n(2+3n)} P(k-k^3)$ $R_4 = \frac{n}{m} P(k-k^3)$
	$M_2 = -\frac{Pln^2}{m} [(2+2n)(2k-3k^2+k^3) - n(k-k^3)]$ $M_3 = -\frac{Pln^2}{m} [(2+2n)(k-k^3) - n(2k-3k^2+k^3)]$ $R_1 = \frac{M_2}{l}, \quad R_2 = P(1-k) - \frac{M_2}{l} + \frac{M_3 - M_2}{nl}$ $R_4 = \frac{M_3}{l}, \quad R_3 = Pk - \frac{M_3}{l} - \frac{M_3 - M_2}{nl}$
	$R_1 = R_4 = \frac{3+6n-n^3}{4(2+3n)} wl$ $R_2 = R_3 = \frac{5+10n+6n^2+n^3}{4(2+3n)}$
	$R_1 = \frac{3+7n+3n^2}{2m} wl$ $R_2 = \frac{1+6n+6n^2}{4n(2+3n)} wl$ $R_3 = -\frac{1+n}{4n(2+3n)} wl$ $R_4 = \frac{n}{4m} wl$
	$R_1 = R_4 = -\frac{n^3}{4(2+3n)} wl$ $R_2 = R_3 = \frac{n(4+6n+n^2)}{4(2+3n)} wl$

23a, 23b, or 24) is the influence line for R_1 . By laying off the ordinates of the curve EC upon the curve BC , we obtain GC as an influence line for $(R_1 + R_2)$.

To obtain the influence diagram for shear in any panel ST of the second span, simply draw a straight line ST across the combined reaction curve GC , as shown in the figure. The areas of the resulting diagram represent shears for unit loading.

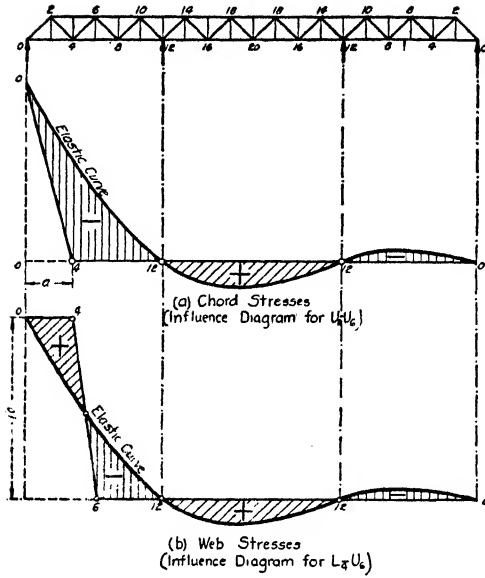

FIG. 25a.—Typical influence diagrams for end spans of a continuous bridge.

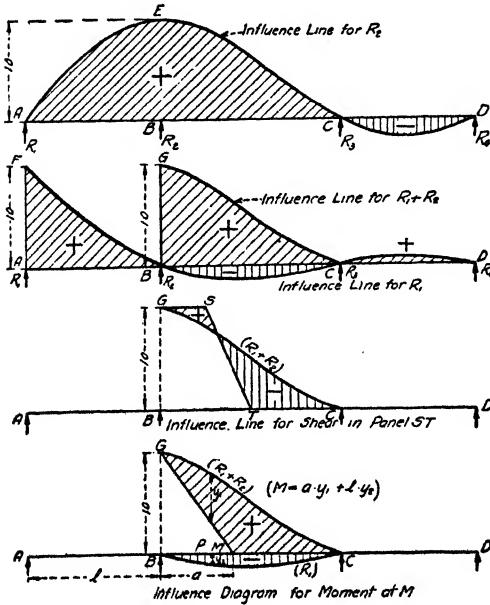

FIG. 25b.—Influence method for intermediate span of a continuous bridge.

To obtain the influence diagram for bending moment at any point M of the second span, simply draw a straight line GM below the curve GC , as shown in the figure. For a unit load at any point P , the value of the bending moment at M will be

$$M = ay_1 + ly_2 \quad (43)$$

where y_1 is the ordinate of the $(R_1 + R_2)$ diagram and y_2 (which has a negative value) is the ordinate of the R_1 curve.

TABLE 10.—BENDING MOMENTS AND SHEARS IN CONTINUOUS GIRDER OF THREE EQUAL SPANS. (ASSUMING UNIFORM l)

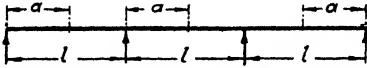

(p = live load/ft.) (w = dead load/ft.)

Point	Max. M	Min. M	Total M	Max. V	Min. V	Total V	
End Spans	$\frac{a}{l} = 0$	pl^2	pl^2	wl^2	pl	pl	wl
	0.1	0.000	0.000	0.000	+ 0.450	- 0.050	+ 0.4
	0.2	+ 0.040	- 0.005	+ 0.035	+ 0.356	- 0.056	+ 0.3
	0.3	+ 0.070	- 0.010	+ 0.060	+ 0.275	- 0.075	+ 0.2
	0.4	+ 0.090	- 0.015	+ 0.075	+ 0.206	- 0.106	+ 0.1
	0.5	+ 0.100	- 0.020	+ 0.080	+ 0.150	- 0.150	0.0
	0.6	+ 0.100	- 0.025	+ 0.075	+ 0.104	- 0.204	- 0.1
	0.7	+ 0.090	- 0.030	+ 0.060	+ 0.069	- 0.269	- 0.2
	0.8	+ 0.070	- 0.035	+ 0.035	+ 0.044	- 0.344	- 0.3
	0.9	+ 0.040	- 0.040	0.000	+ 0.028	- 0.428	- 0.4
	1.0	+ 0.020	- 0.065	- 0.045	+ 0.019	- 0.519	- 0.5
Middle Span	$\frac{a}{l} = 0$	+ 0.017	- 0.117	- 0.100	+ 0.583	- 0.083	+ 0.5
	0.1	+ 0.015	- 0.070	- 0.055	+ 0.487	- 0.087	+ 0.4
	0.2	+ 0.030	- 0.050	- 0.020	+ 0.399	- 0.099	+ 0.3
	0.3	+ 0.055	- 0.050	+ 0.005	+ 0.321	- 0.121	+ 0.2
	0.4	+ 0.070	- 0.050	+ 0.020	+ 0.254	- 0.154	+ 0.1
	0.5	+ 0.075	- 0.050	+ 0.025	+ 0.198	- 0.198	0.0

In this manner, by simply using the two influence curves GC and BC , we avoid the necessity of constructing a different influence curve for each member of the span. If such influence lines are desired, however, they may be easily constructed from the last diagram in Fig. 25b, by subtracting from the ordinates of GC , the ordinates of BC multiplied by $\frac{l}{a}$.

The influence lines shown for the intermediate span *BC* in Fig. 25*b* may be extended to cover loads in the other spans; but it will be more expeditious to treat the other spans as complete load-units, and to calculate independently their contributions to the desired stresses in span *BC*.

36. Continuous Bridge of Three Equal Spans.—For a continuous bridge of three equal spans (with constant *I*), Eqs. (36) to (42) inclusive, and the expressions in Table 9 become considerably simplified by the substitution of *n* = 1 and *m* = 15.

For load covering the first span, we find (from Table 9),

$$\left. \begin{aligned} R_1 &= \frac{13}{30}wl = 0.4333wl \\ R_2 &= \frac{13}{20}wl = 0.6500wl \\ R_3 &= -\frac{1}{10}wl = -0.1000wl \\ R_4 &= \frac{1}{60}wl = 0.0167wl \end{aligned} \right\} \quad (44)$$

For load covering the middle span, we find (from Table 9),

$$\left. \begin{aligned} R_1 = R_4 &= -\frac{1}{20}wl = -0.0500wl \\ R_2 = R_3 &= \frac{11}{20}wl = 0.5500wl \end{aligned} \right\} \quad (45)$$

For load covering all three spans, we find (from Table 9),

$$\left. \begin{aligned} R_1 = R_4 &= \frac{2}{5}wl = 0.4000wl \\ R_2 = R_3 &= \frac{11}{10}wl = 1.1000wl \end{aligned} \right\} \quad (46)$$

With the aid of the foregoing values of the reactions, we obtain the maximum moments and shears for a continuous bridge of three equal spans. These values are tabulated in Table 10.

37. Multiple-span Continuous Girders.—Continuous girders of more than three or four spans may be treated by an extension of the principles employed in the preceding sections.

If the spans are equal (and *I* is assumed constant), the governing values for full loading may be taken directly from Table 11. In this table

- R_1, R_2, \dots = the reactions at the supports.
- M_2, M_3, \dots = the (negative) moments over the supports
- Max. M_1 , Max. M_2, \dots = the greatest (positive) moments in the respective spans.
- x_1, x_2, \dots = the distances of Max. M_1 , Max. M_2, \dots , from the adjacent left supports.
- f_1, f_2, \dots = the distances of the points of contraflexure from the adjacent left supports.
- l = the length of each span
- w = the uniform load per unit length

Since all relations are symmetrical about the center line, the tabulated values are extended only to the mid-point.

As the number of spans is increased, all of the tabulated values for intermediate spans approach, as a limit, the corresponding values for a single-span beam with fixed ends. The values for the end spans correspond approximately (or exactly in the case of only three supports) to the respective values for a single-span beam with one end fixed.

TABLE 11.—CONTINUOUS GIRDERS OF EQUAL SPANS ($I = \text{CONSTANT}$) (LOADED UNIFORMLY OVER THE ENTIRE LENGTH)

Quantity	Number of spans							Unit
	2	3	4	5	6	7	8	
R_1	0.3750	0.4000	0.3929	0.3947	0.3942	0.3944	0.3943	wl
R_2	1.2500	1.1000	1.1428	1.1317	1.1346	1.1337	1.1340	
R_3	—	—	0.9286	0.9736	0.9616	0.9649	0.9640	
R_4	—	—	—	—	1.0192	1.0070	1.0103	
R_5	—	—	—	—	—	—	0.9948	
M_2	0.1250	0.1000	0.1071	0.1053	0.1058	0.1056	0.1057	wl^2
M_3	—	—	0.0714	0.0789	0.0769	0.0775	0.0773	
M_4	—	—	—	—	0.0865	0.0845	0.0850	
M_5	—	—	—	—	—	—	0.0825	
Max. M_1	0.0703	0.0800	0.0772	0.0779	0.0777	0.0778	0.0777	
Max. M_2	—	0.0250	0.0364	0.0332	0.0340	0.0338	0.0339	wl^2
Max. M_3	—	—	—	0.0461	0.0433	0.0440	0.0438	
Max. M_4	—	—	—	—	—	0.0405	0.0412	
Max. M_5	—	—	—	—	—	—	—	
X_1	0.3750	0.4000	0.3930	0.3947	0.3942	0.3944	0.3943	l
X_2	—	0.5000	0.5357	0.5264	0.5327	0.5281	0.5283	
X_3	—	—	—	0.5000	0.4904	0.4930	0.4923	
X_4	—	—	—	—	—	0.5000	0.5026	
f_1	0.7500	0.8000	0.7860	0.7894	0.7884	0.7887	0.7887	l
f_2	—	0.2760	0.2659	0.2680	0.2675	0.2680	0.2680	
	—	0.7240	0.8055	0.7830	0.7899	0.7884	0.7890	
f_3	—	—	—	0.1964	0.1960	0.1962	0.1960	
	—	—	—	0.8036	0.7850	0.7897	0.7880	
f_4	—	—	—	—	—	0.2153	0.2150	
	—	—	—	—	—	0.7847	0.7900	

38. Fixed Points in Continuous Spans.—In any continuous girder (Fig. 26a), there are certain critical points which have useful properties in facilitating graphic methods and in indicating load placement for maximum stresses. These points, one in each end span and two in each intermediate span, are independent of the loading and are fixed in position in any given structure; hence they are called "fixed points."

In a uniform continuous beam of two equal spans, the fixed points are located at $0.2l$ from the middle support. In the case of three equal spans, the fixed point (R_1 or L_3) in each end span is at $0.21l$, and the fixed points (L_2, R_2) in the middle span are at $0.2l$ from the intermediate supports.

For any three symmetrical spans (with constant I), the fixed points (L_2, R_2) in the middle span will be distant from the nearest supports

$$f = \frac{n}{2 + 3n} \cdot nl \tag{47}$$

and the fixed points (R_1, L_3) in the outer spans will be near the intermediate supports at a distance

$$f = \frac{2n + 2}{m + 2n + 2} \cdot l \tag{48}$$

where n is the ratio of middle span to end span, and $m = (2 + n)(2 + 3n)$.

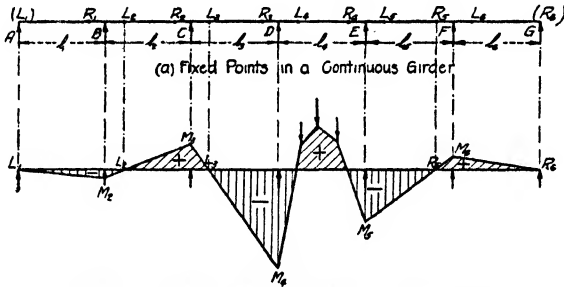

(b) Moment Diagram Constructed with Aid of Fixed Points

FIG. 26.

For the general case (any number of spans, any lengths, constant I), the fixed points may be located by certain graphic methods or, analytically, as follows: The first L -point (Fig. 26a) will be L_2 in the second span l_2 ; it will divide that span into two segments whose ratio is given by

$$\frac{CL_2}{BL_2} = r_2 = \frac{2(l_1 + l_2)}{l_2} \tag{49}$$

In the next span, L_3 is located by the segment-ratio

$$\frac{DL_3}{CL_3} = r_3 = -\frac{l_2}{l_3 r_2} + \frac{2(l_2 + l_3)}{l_3} \tag{50}$$

Repeating the operation represented by this equation, each successive value of r is figured from the preceding value, until all the L -points are determined. Commencing at the right end of the structure, and going through the same operation toward the left, all the R -points are determined in like manner.

For any number of equal spans, the successive values of r by Eqs. (49) and (50) will be 4, 3.75, 3.733, 3.732, 3.732, . . . ; hence, all values

of f will be $0.21l$ except the first and last (BL_2 and FR_5 , Fig. 26a) which will be $0.20l$.

The fixed points may also be located from the elastic curves; this is particularly convenient when I is variable. A tangent to the elastic curve at A (Fig. 14, 17, 18, 20, 23 or 24) will intersect the base in the first fixed point. This will yield $f = 0.2l$ in the case of uniform I , Fig. 14; $f = 0.333l$ in the case of triangular variation of I , Fig. 18; and $f = 0.194l$ in the case of the Sciotoville Bridge, Fig. 17. In a three-span girder, Fig. 25b, the right fixed point in the middle span is located by the ratio of the slopes of the tangents at C to the two curves CB and CG .

The outer supports may also be regarded as fixed points, so there will be two fixed points in each span.

Designating the left fixed point in each span by L and the right fixed point by R , we may state the following useful principle (Fig. 26b):

For any loading in any span, the resultant bending moment diagram will pass through the fixed points L of all spans to the left, and through the fixed points R of all spans to the right. These "fixed points" are consequently points of zero bending moment, or fixed points of contraflexure, for unloaded spans.

Since the bending moment diagram in each unloaded span is a straight line passing through one of the fixed points, the location-ratio r of each fixed point determines the ratio between the bending moments M over the adjacent supports. All of these bending moments thus become known as soon as one is known.

A corresponding analytical procedure for finding any of the moments directly is represented by Merriman's general formulas for continuous girders (MERRIMAN and JACOBY "Higher Structures," p. 33, 1905).

39. General Rules for Loading Placement.—The placement of loading for maximum stresses is given by the following general rules:

(1) For maximum positive bending moment at any section located between the two "fixed points" of any span, the load should cover that span and all alternate spans. For maximum negative bending moment, the given span and all alternate spans should be free from load.

(2) For maximum positive bending moment at a section outside of the "fixed points" of any span, a segment of the span including the section is loaded; the adjacent span, the remaining segment of the given span, and all alternate spans should be free from load. For maximum negative bending moment, apply the opposite loading.

(3) For maximum negative bending moment over any intermediate support, load the two adjoining spans and all alternate spans. The same loading also gives the maximum positive reaction at the support.

(4) For maximum positive shear at any section of any span, load the span-segment to the right of the given section and all alternate spans

to the right; also load the left adjacent span and all alternate spans to the left. For maximum negative shear, apply the opposite loading.

40. Effect of Settlement of Supports.—In a continuous beam of two equal spans l , with constant I , the settlement of the middle support through a distance D will produce a relieving moment at that support defined by

$$M_2 = \frac{3EI}{l^2} D \quad (51)$$

The relief of the middle reaction will be

$$-R_2 = 2 \frac{M_2}{l} \quad (52)$$

and each end reaction will be augmented by the amount

$$R_1 = R_3 = \frac{M_2}{l} \quad (53)$$

The settlement of both end supports through distances D , or of one end support through a distance $2D$, will produce effects equal, but opposite in sign, to those defined by Eqs. (51), (52) and (53).

If the spans are unequal, or if the moment of inertia I is variable, calculate the deflection d producible at the given support if that support were removed and a unit-load substituted. Then, a settlement D would produce an increase in that reaction defined by

$$R = -\frac{D}{d} \quad (54)$$

This principle can be applied to a continuous bridge of more than two spans.

In a symmetrical three-span bridge of constant I (see Table 9), a settlement D_1 of the end support will produce, over the intermediate supports, bending moments defined by

$$M_2 = -\frac{12EI(1+n)}{ml^2} \cdot D_1 \quad (55)$$

$$M_3 = \frac{6EI n}{ml^2} \cdot D_1 \quad (56)$$

The accompanying changes in the four reactions are easily figured from these values of M_2 and M_3 . If the three spans are equal, the reaction-changes will be:

$$R_1, R_2, R_3, R_4 = -\frac{24}{15}, +\frac{54}{15}, -\frac{36}{15}, +\frac{6}{15} \frac{EID_1}{l^3} \quad (57)$$

For a settlement D_2 of the second support, the resulting reaction-changes (in a bridge of three equal spans) will be:

$$R_1, R_2, R_3, R_4 = +\frac{54}{15}, -\frac{144}{15}, +\frac{126}{15}, -\frac{36}{15} \frac{EID_2}{l^3} \quad (58)$$

On account of the increased constraint in a three-span bridge, the reaction-changes R_1, R_2, R_3 , produced by D_1 or D_2 , are somewhat greater than the corresponding reaction changes in a two-span bridge. The change in the remote reaction, R_4 , however, is comparatively slight.

The identity between R_2 of Eq. (57) and R_1 of Eq. (58) is an illustration of the application of Maxwell's "Principle of Reciprocal Deflections." Note also, the identity of the symmetrically located reactions.

It will generally be advantageous to make the intermediate supports intentionally lower than the end supports by a small and predetermined amount when the bridge is erected. The excess of middle reactions over end reactions can thus be somewhat relieved, and the greatest negative and positive moments can be equalized. In a two-span girder of equal spans (l) and constant I , it will be advantageous to drop the middle support an amount defined by

$$D = (1.9w + p) \frac{l^4}{145 EI} \quad (59)$$

where w = dead load, and p = live load per linear foot. This will reduce the negative moment over the middle support about 16 to 31 per cent (depending on the ratio of w to p) and will increase the maximum positive moment within the span to an equal value.

For the Sciotoville Bridge, $l = 775$ ft., the necessary camber or lowering corresponding to Eq. (59) would be about 1.1 ft.

For a three-span continuous girder of total length L , with ratio of spans between 8:9:8 and 6:7:6, the advantageous lowering of both intermediate supports is defined by

$$D_2 = (1.8w + p) \frac{L^4}{5,900 EI} \quad (60)$$

For other cases, the advantageous lowering of the intermediate supports may be determined in the design calculations by trial.

In a continuous beam or girder of constant section, the above-described lowering of the middle support produces a material increase in strength. In the case of a continuous truss, the lowering would result in greater uniformity of chord sections, reducing the extreme maximum sections which are required over the intermediate supports.

From the same considerations, it is also obvious that the natural settlement or compression of the middle supports of a continuous bridge (in excess of the simultaneous settlement of the end supports) will be advantageous rather than detrimental to the safety of the structure, inasmuch as it tends to produce an equalization of absolute values of maximum and minimum moments (with the reduction in maximum considerably greater than the increase in minimum moments), and a desirable relief in the excessive intermediate reactions. In other words, natural adjustments by settlement are really an element of inherent safety in a continuous bridge.

41. Example—Effect of Settlement in Sciotoville Bridge.—Referring to Tables 4 and 5, and figuring absolute values instead of relative values, we find the end displacement producible by unit applied load (1 lb.) to be

$$d = 20,882 \frac{77.5}{10,000 E} = 0.0000056 \text{ ft.}$$

Accordingly, applying Eq. (54) a settlement of 1 in. ($D = 0.0833$) will produce a relief in the end reaction amounting to

$$-R_1 = \frac{D}{d} = 15,000 \text{ lb.}$$

This is only 0.6 of 1 per cent of the total dead-load reaction, or 0.3 of 1 per cent of the total ($D + L + I$) reaction. The simultaneous increase in the middle reaction will be twice this amount, or 30,000 lb., which is only 0.3 of 1 per cent of the dead load reaction, or 0.2 of 1 per cent of the total ($D + L + I$) reaction at the middle support.

A settlement of 1 in. at the middle support will produce effects equal to twice those given in the preceding paragraph, but opposite in sign. The middle reaction would be relieved 60,000 lb., or less than 0.4 of 1 per cent of the total ($D + L + I$) reaction at the middle support.

It is evident from these values that any ordinary settlement of the piers would affect the stresses in the structure to so small an extent as to be negligible.

42. Continuous Bridges 1923-1942.—During the past twenty years the construction of continuous bridges has been noteworthy, particularly in the highway field. Prior to this period very few bridges of this type were designed or constructed in this country. This was undoubtedly due to a large extent to the fact that settlement of the supports affected the stresses in the superstructure. Many engineers considered that it was poor practice to use a continuous type of superstructure unless its supports were founded on unyielding foundations. It has been shown in the previous articles that relatively small settlements of the supports of the superstructures of long-span continuous bridges do not seriously affect the stresses. Furthermore it has been demonstrated that by the use of continuity considerable economy and increased rigidity is secured. A great deal of study and thought has been given to developing a type of superstructure that would not only have these desirable characteristics but would also not be materially affected by settlements of such magnitude as would be seriously objectionable in the conventional type. In 1932 Mr. Wichert produced a type of superstructure which fulfilled these requirements in a successful and practical manner. As the Wichert truss has been very thoroughly discussed elsewhere,¹ only a brief description of it will be given here.

¹D. B. Steinman, "The Wichert Truss," D. Van Nostrand Company, Inc., New York.

Mr. Wichert found by introducing four hinges or pinned connections at the intermediate supports or piers (Fig. 27), that all the advantages of continuity were preserved, that relatively large pier settlements had little effect on the stresses, and also that the structure became statically determinate. Although it is claimed that the Wichert type requires less

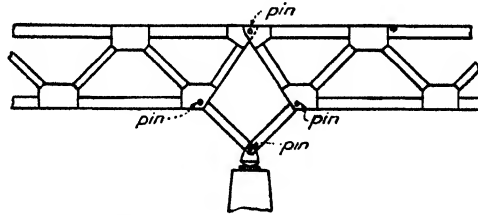

FIG. 27.—Typical arrangement of members at pier, Wichert truss.

steel than the conventional type, the latter should not be eliminated from consideration, as the hinged connections, as well as other characteristics, may show little if any saving in the final cost of the Wichert type over that of the conventional type. If the character of the foundation material is such that pier settlements of considerable magnitude might occur, and if a relocation of the bridge to secure more favorable foundation conditions is impracticable, then the Wichert truss has a real advantage over the conventional type.

In the following articles several bridges having continuous superstructures of both types will be described. These bridges have been selected as being typical and represent only a few of the many now existing in this country.

43. The C. and O. Railroad Bridge, Cincinnati, Ohio.—Construction of this bridge was started in 1927 and was completed in 1929 (Fig. 28). The main portion of this bridge consists of a double track three-span continuous through steel truss of the conventional type supported on reinforced concrete piers. The two shore piers rest on reinforced con-



FIG. 28.—C. and O. Railroad Bridge, Cincinnati, Ohio.

crete piles driven to refusal. One of the river piers is of new construction throughout, and the other consists of an existing pier with a reinforced concrete extension added to the downstream end. Both river piers rest on unyielding foundation material of alternate thin layers of shale and sandstone, some 60 ft. below river level.

Because of the large longitudinal force, resulting from the starting and stopping of trains on the bridge, and because of the relatively high

river piers, the fixed shoes were placed on one of the shore piers, with expansion shoes on each of the other piers. Expansion is provided by segmental rollers 2 ft. in diameter, protected from dirt and corrosion by steel housings filled with oil.

The spans are 450 ft., 675 ft., and 450 ft., making the trusses the longest of their kind at the time of their erection. In order to keep the dead load as light as possible, all members of the superstructure are of silicon steel, which has a working stress of 24,000 lb. per sq. in. Secondary stresses were provided for in the design when it was impractical to eliminate them. The maximum secondary stresses will occur in the inclined posts and bottom chord members at the intermediate piers if provision is not made for their elimination or reduction. In this bridge the secondary stresses were eliminated in the inclined posts by providing them with pin connections. In the bottom chords they were materially reduced by shortening the subverticals and forcing the chord members to connect with them. The stresses produced by this action are relieved when the bridge is fully swung and in its final position.

Full continuity over the three spans was assumed in the design of the bottom lateral system. The top lateral system was designed to act as three simple spans between the upper ends of the inclined posts at the shore and river piers.

As it was necessary to maintain river as well as railroad traffic the scheme of erection adopted did not require falsework in the river channel. The end spans were erected on falsework supported on timber piles with the center span cantilevered out from the river piers to closure at mid-span. The shore ends of the trusses were held approximately 3 ft. below their final positions until closure was made at the center of the middle span. At closure the bottom chord connection was first made; afterward one end of the truss was raised until the top chord could be connected. Following the chord connections both ends of the truss were jacked up sufficiently to permit the erection of the end shoes.

The last step in the erection was the weighing in of the end reactions. This was done by jacking up the end bearings until predetermined dead load reactions were secured. These reactions were measured by pressure gauges placed in the hydraulic jacking system. Shims were placed between the bottom chords and the upper shoe castings when necessary to maintain the required reactions.¹

44. Lake Champlain Bridge.—Continuity has been used in the conventional manner to a large extent in the design of the superstructure of this high level highway bridge which was completed in 1929 (Fig. 29). The main portion of the superstructure consists of a series of truss spans,

¹ For a detailed description of this bridge see paper by WILSON T. BULLARD, "Three Span Continuous-truss Railroad Bridge," *Trans. Am. Soc. Civil Eng.*, vol. 99, p. 873.

made up of one three-span continuous truss flanked on the one hand by a simple span and on the other by a two-span continuous truss. The remainder of the superstructure is made up of a series of deck plate girder spans on each approach. These spans were designed to act as simple spans under dead load and as continuous spans under live load. The spans of the three-span continuous truss are 290 ft., 434 ft., and 290 ft. The two-span continuous truss has spans of 270 ft. and 225 ft., with the longer span adjacent to the three-span truss. The simple span is 270 ft. long, and the total length of the superstructure is approximately 2,200 ft.

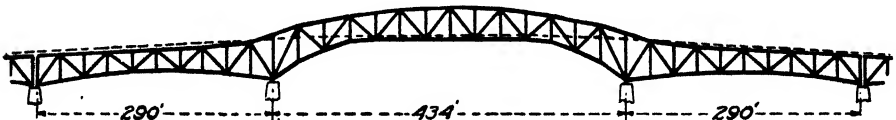

FIG. 29.—Continuous three-span truss, Lake Champlain Bridge.

The simple span and the shorter span of the two-span continuous truss were erected on falsework. The longer span of the two-span truss was erected in two operations by cantilevering out from the pier and end of the shorter span to the temporary bents and thence to the pier supporting the end of the three-span truss. The end spans of this truss were erected on falsework and the center span was cantilevered out from each pier, with closure being made at the middle span. The closure and weighing in of the dead load reactions of the spans were carried out in a similar manner to that of the C. and O. railroad bridge.

45. Sagamore Bridge over Cape Cod Canal, Massachusetts.—This structure consists of a three-span continuous truss, somewhat similar to the three-span continuous truss of the Lake Champlain Bridge. A portion of the floor in the center span, however, is suspended from the trusses. This permits a maximum vertical clearance above the canal level for the larger part of the span. The spans are 396 ft., 616 ft., and 396 ft. in length.

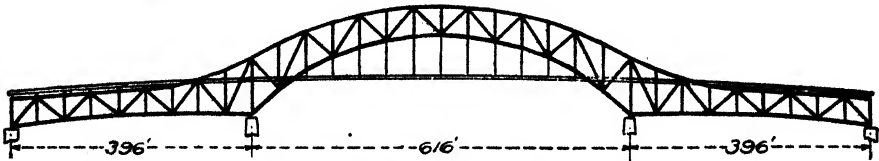

FIG. 30.—Continuous truss bridge over Cape Cod Canal, Sagamore, Mass.

The erection of the superstructure was carried out in the conventional manner, except for the weighing in of the dead load end reactions. The specifications required that this operation be made within a tolerance of 1 per cent. The usual method of measuring the reactions by hydraulic jacks equipped with pressure gauges will not give this precision. A

device known as a "proving ring" gives results with the necessary precision and was used on this bridge. This instrument consists of a heavy steel ring with a stiff metal reed mounted rigidly on the inside so that its axis projects through the center of the ring. Directly opposite the reed a metal disk is mounted on a micrometer screw in such a manner that the disk can be moved to and from the free end of the reed. The ring is loaded at points directly in line with the axis of the reed. Under load the ring deforms, becoming slightly elliptical with the shorter axis in line with that of the reed. This deformation is measured by placing the reed in vibration and advancing the disk until it just comes in contact with it. This point of contact can be very accurately determined by observing the action of the reed. With the ring calibrated for known loads, the value of the measured loads is easily determined. This device proved quite satisfactory and has been used on other continuous bridges for the accurate weighing in of the end reactions.

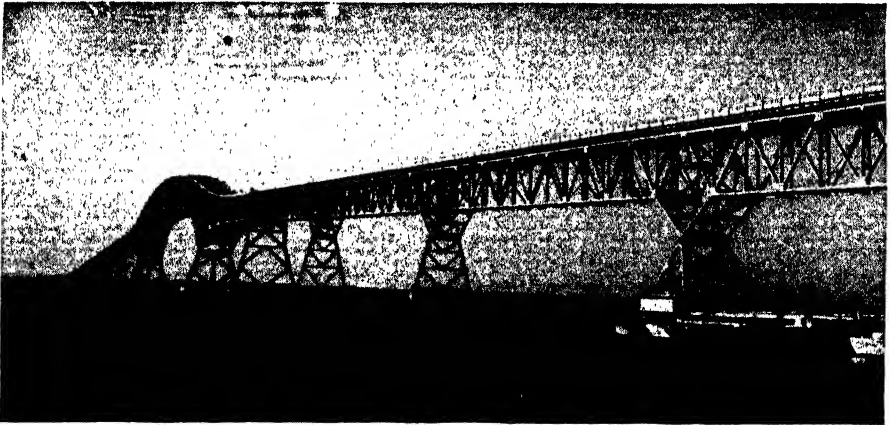

FIG. 31.—Ludlow Ferry Bridge over Potomac River. (Courtesy of W. C. Hopkins, bridge engineer State Roads Commission, State of Maryland.)

46. Ludlow Ferry Bridge over Potomac River.—This structure, a high level highway bridge of the Wichert type, spans the Potomac River (Fig. 31). It has a total length of 10,000 ft. made up of 60 continuous steel beam spans of 61.5 ft. each; 8 continuous plate girder spans of 162 ft. each; 4 continuous plate girder spans of 117 ft. each; 2 continuous truss units having spans of 276 ft., 350 ft., and 276 ft. in each unit; 1 continuous truss unit having spans of 276 ft., two at 350 ft., and one at 276 ft. In addition to the continuous spans there is a steel cantilever unit having spans of 370 ft., 800 ft., and 370 ft. The middle span of 800 ft. is over the main channel and has a vertical clearance of 135 ft. above the river level. This bridge has a clear roadway width of 24 ft., with a 1.5-ft. emergency walk on each side. The beam spans carry a conventional

concrete floor and all other spans have a concrete-filled steel grid type. All piers were carried on steel H-piles from 150 to 193 ft. long driven to solid rock, except those on the Maryland shore. These piers were carried on timber and cast-in-place concrete piles.

The cost of this bridge was approximately \$5,000,000.

47. Hancock Bridge over Potomac River.—This structure is another high level highway bridge of the Wichert type. It spans the Potomac River, the C. and O. Canal, the B. and O. Railroad, the Western Maryland Railroad, and Highway 40 from Hancock, Md., to West Virginia (Fig. 32). It has a total length of 3,157 ft., made up of one continuous plate girder unit having one span of 130 ft., two of 160 ft., and one of 130 ft.; two con-



FIG. 32.—Hancock Bridge over Potomac River. (Courtesy of W. C. Hopkins, bridge engineer State Roads Commission, State of Maryland.)

tinuous plate girder units having one span of 100 ft., three of 140 ft., and one of 100 ft. for each unit; one continuous truss unit having one span of 118 ft., four of 196 ft., and one of 118 ft.; and also seven beam spans of 44 ft. each. All spans carry a conventional concrete floor. The roadway, which has a clear width of 24 ft. with a 3-ft. sidewalk on each side, is 84 ft. above normal water and 42 ft. above the highest recorded flood water. The substructure is of reinforced concrete supported on shale or gravel strata, the bearing capacity of which was proved by loading tests.

The cost of this structure was approximately \$790,000.

48. Licking Creek Bridge, Maryland, and Sagamore Creek Bridge, New Hampshire.—These bridges have been selected more for a comparison between the Wichert and conventional type of continuous bridge.

superstructure than as examples of long span construction (Figs. 33 and 34).

The Licking Creek Bridge is of the Wichert type and has a total length of 300 ft. made up of one continuous deck plate girder unit having spans of 90 ft., 120 ft., and 90 ft. The roadway has a clear width of 26 ft.,



FIG. 33.—Licking Creek Bridge, Maryland. (Courtesy of W. C. Hopkins, bridge engineer State Roads Commission, State of Maryland.)



FIG. 34.—Sagamore Creek Bridge, New Hampshire.

with a 2.25-ft. emergency walk on each side. All spans carry a conventional concrete floor. The substructure is of reinforced concrete carried to solid rock. The cost of this bridge was \$152,000.

The Sagamore Creek Bridge is of the conventional type and has a total length of 391 ft. made up of one continuous deck plate girder unit

having spans of 116.5 ft., 158 ft., and 116.5 ft. The roadway has a clear width of 26 ft., with a 3-ft. emergency walk on each side. All spans carry an open steel grid floor, 5 in. in depth. The floors of the walks are also of open steel grid, 2 in. in depth. The substructure is of reinforced concrete carried to solid rock or cemented shale. As this bridge spans a tidewater creek, the intermediate piers are sheathed with wrought iron from a point approximately 2 ft. below extreme low water up to the underside of the cap. The abutments are protected from the action of the tidewater by the approach fills and stone riprap. The cost of this bridge was \$97,750.

Whereas it is evident that these two bridges are quite similar, except for span lengths and type, the first costs would indicate that the conventional type is the more economical. Such a conclusion, however, would not be justified without a careful study of both types for each bridge site. Such a study would undoubtedly show both types in such close competition that actual bids would have to be taken on alternate designs to determine which of the two types is more economical.

SECTION 5

CANTILEVER BRIDGES

1. **Cantilever Bridges Compared with Continuous Bridges.**—Multiple span bridges may be continuous, partially continuous, or discontinuous. In Europe the continuous bridge is often preferred, and French engineers rarely build girders of more than one span without making them continuous. In America, adherence to statically determinate types has been very persistent, and the cantilever in place of the continuous bridge has been highly developed. The latter type has, however, grown in favor, and recent years have brought great development along this line.

The partially continuous type is exemplified in such structures as the Queensboro Bridge and Minnehaha Bridge, which are cantilevers with suspended spans omitted and cantilever arms joined.

The chief advantages shared alike by the cantilever and continuous bridge are (1) economy of material, (2) saving in width of piers which may carry one support instead of two as in the case of a series of simple spans, and (3) ease of erection and saving of falsework, as explained later.

The disadvantage of the continuous bridge, which, however, obtains only in case rigid foundations cannot be secured or convenient means of adjustment made, is that small changes of level in the supports may cause great changes or reversal of stress and even lead to complete failure. This disadvantage is avoided by the proper use of the cantilever principle while all the chief advantages of the continuous type are preserved. For small multiple span girder bridges the cantilever type is undoubtedly preferable to the continuous.

2. **The Cantilever Bridge as a Development of the Continuous Bridge.** Although the cantilever principle is very old historically, the modern



FIG. 1.

cantilever bridge is a development of the continuous bridge. Figure 1 indicates a three-span bridge. If the bridge is continuous there are four points of contraflexure as indicated, where the moment is equal to zero, and the position of these points changes within narrow limits for

different systems of loading. Ritter, in 1860, proposed in effect to make the structure hinged at these points and discontinuous. It is seen, however, that the resulting structure would be unstable, as an unbalanced load would cause the several units to rotate on their points of support and the bridge as a whole to collapse. If, however, hinges are introduced at two points only, as indicated in Figs. 2, 3 or 4, the resulting structures are stable, providing proper provision is made for negative reactions and, as will be shown, they are statically determinate.

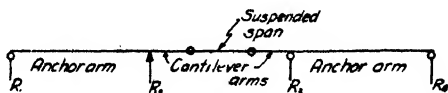

FIG. 2

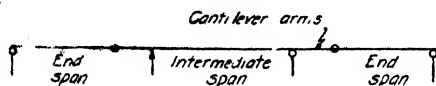

FIG. 3.

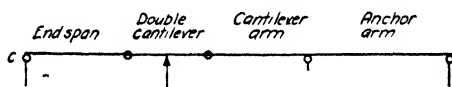

FIG. 4.

3. Statically Determinate and Statically Indeterminate Cantilever Bridges.—Certain conditions must be observed in the design of statically determinate cantilevers. In some instances designs have been made without a full understanding of the principles involved, although there are several examples in which the indeterminate type was purposely selected. A full discussion of the principles of statical determination as peculiarly applied to cantilever bridges is therefore essential to a clear understanding of the general subject.

4. Conditions of Statical Determination.—A structure supported at n points has $2n$ unknown components of the reactions— n vertical and n horizontal. Part of these unknowns may be eliminated by placing some of the supports on rollers, but one reaction at least must be capable of developing a horizontal as well as vertical component to preserve stability. Assume first that $n - 1$ supports are on rollers. There remain $n + 1$ unknown quantities and $n + 1$ equations are required to solve them. Statics gives us the three general equations ($\Sigma H = 0$, $\Sigma V = 0$, $\Sigma M = 0$). $n - 2$ equations remain to be supplied. In a continuous bridge they are supplied by the theory of elasticity. In the cantilever bridge the equations necessary to secure statical determination are established by certain features of construction and are called equations of condition. As a concrete example consider the structure indicated

in Fig. 5. Reactions R_1 , R_3 and R_4 are applied through roller bearings. There are, therefore, five unknown components of reactions. To solve these we have the three general static equations. Two equations of condition must then be supplied, which is done by introducing the two hinges as shown; and the equations of condition are $\Sigma M_a = 0$ and $\Sigma M_b = 0$, which means that the moment of all the outer forces on *either* side of either hinge is equal to zero. These equations must not be confused

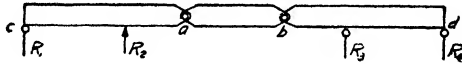

FIG. 5.

with the general equation $\Sigma M = 0$, which is applicable at any point of the structure and means that the *sum* of the moments on *both* sides of the point is equal to zero. Also with regard to the moment about the hinges, it must not be assumed that each condition supplied gives two independent equations, since, if the moment of all the outer forces to one side of the hinge is equal to zero, the fact that the moment of all forces to the other side is equal to zero follows immediately.

The proper number of equations of condition may be supplied in another way, as indicated in Figs. 6A and 6B. There are four reactions,

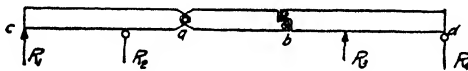

FIG. 6A.

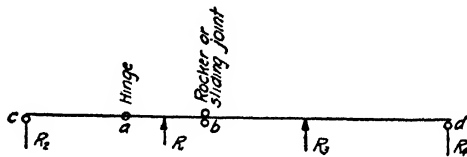

FIG. 6B.

two of which are applied through roller bearings. There are six unknown components of reactions and three equations of condition are required. Hinge *a* supplies $\Sigma M_a = 0$ and rocker *b* supplies $\Sigma M_b = 0$ and $\Sigma H_b = 0$. Also consider the structure illustrated in Fig. 15. There are eight unknown components of reactions and five equations of condition must be established. Two are established by omitting the (dotted) diagonals over the center piers which gives $M_7 = M_8$ and $M_{22} = M_{23}$ and three more by omitting the bars *U12-13*, *U17-18* and *L18-19* and introducing the hinge at 12 ($\Sigma M_{12} = 0$) and the rocker at 18 ($\Sigma M_{18} = 0$, $\Sigma H_{18} = 0$).

If there are too many equations of condition, the structure will be unstable if supported at points, as illustrated in Fig. 7. In this case

there are six unknowns and three equations of condition are required, whereas four are furnished by the hinges. If the points of supports are wide piers, however, the structure may still be stable; but in this case each pier in reality furnishes two points of support (see Fig. 8). For this particular case the piers must be wide enough to prevent overturning

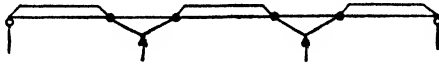

FIG. 7.

under any condition of loading or else the columns of the piers anchored against uplift; and differs from the arrangement shown in Fig. 15 in which R_2 and R_3 are always positive if the diagonals over the piers are omitted.

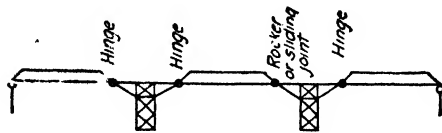

FIG. 8.

Again in Figs. 6A and 6B, if one of the fixed bearings is made a roller bearing, there will be five unknown components of reactions and two equations of condition are required, whereas one is furnished by the hinge and two by the rocker. If R_3 is made a roller bearing, the part of the bridge $b-d$ will be unstable. If R_1 is made a roller bearing, the part of the bridge $c-b$ will be unstable.

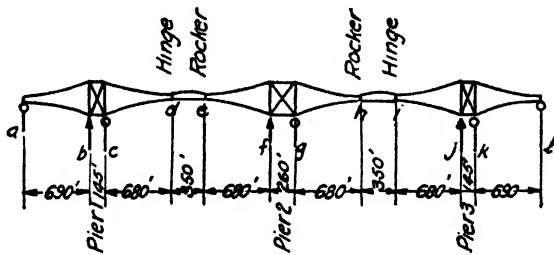

FIG. 9.—Forth Bridge, Scotland.

If too few equations of condition are established, the structure is stable but statically indeterminate.

A study of the possible ways of treating a structure of the type of the Forth Bridge, Scotland, will make clear the whole subject of statical determination of cantilever bridges.

Case I.—The Forth Bridge, shown in Fig. 9, is supported at a , g , k and l , on expansion bearings, and at b , f and j on fixed bearings. At d and i are hinges and at e and h are rockers. There are diagonals

over each pier. The width of Pier 2 is such that overturning is prevented under any condition of live load. Piers 1 and 3 are narrower and anchorages are provided to take uplift at the shore ends of the end cantilever arms. There are then 11 components of reactions and eight equations of condition are required for statical determination. Two are supplied by the two hinges and four by the two rockers—six in all. Two conditions are lacking and the structure is indeterminate; the end cantilevers being continuous on three supports.

Case II.—If the diagonals over Piers 1 and 3 were omitted the equations $M_b = M_c$ and $M_j = M_k$ would be established and the structure would be determinate.

Case III.—If, in addition, the diagonals over Pier 2 were omitted, too many conditions would be supplied and the structure would be unstable, as is clearly seen. The middle cantilever would collapse under unbalanced load.

Case IV.—Assume now the original structure with diagonals over all three piers. If supports at a and l are omitted, the six required equations of condition are supplied by the hinges and rockers and the structure is stable and determinate, providing Piers 1 and 3 are made wide enough to prevent overturning or the legs of the towers anchored against uplift.

Case V.—Suppose now that the structure is supported at b, c, g, j and k on expansion bearings, and that f is fixed; that there are no supports at a and l ; that the diagonals over Piers 1 and 3 are retained, and that there are hinges at d, e, h and i , but no rockers. There are seven components of reactions and the four required equations of condition are supplied by the four hinges. The structure is stable and determinate.

Case VI.—If in addition to the conditions assumed in Case V, the diagonals over any pier were omitted, there would be too many conditions and part of the structure would be unstable.

Case VII.—Suppose the structure is supported at a, b, c, g, j, k , and l on expansion bearings and that f is fixed; also that hinges are placed at d, e, h and i . If the diagonals over Piers 1 and 3 are omitted, the structure is stable and determinate.

Case VIII.—If the conditions are the same as for Case VII but the diagonals over Piers 1 and 3 are retained, the structure is indeterminate.

In any case diagonals over Pier 2 are required to preserve stability of the middle cantilever, which furnishes supports but is itself unsupported at e and h .

Cases V to VIII are, of course, impracticable for a structure of the magnitude of the Forth Bridge, as it was assumed that expansion would be transmitted through the massive cantilever units. The supposed cases do, however, illustrate the possibilities of a simpler structure.

5. Examples of Cantilever Bridges.—We are now in position to examine typical structures and point out their degree of determinateness without further discussion.

Blackwell's Island, or the Queensboro, Bridge connecting Manhattan, N. Y., with the Borough of Queens is illustrated in Fig. 10. Here the

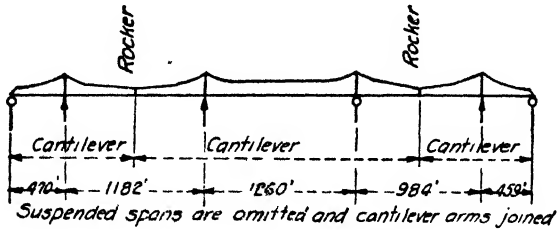

FIG. 10.—Queensboro Bridge.

suspended span is omitted and the cantilever arms joined with a rocker connection. There are nine unknowns and only four equations of condition are supplied by the two rocker connections. Two conditions are lacking and the bridge is statically indeterminate. To provide for

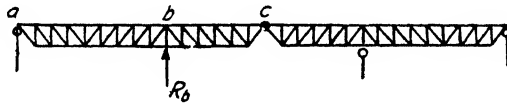

FIG. 11.—Minnehaha Bridge.

adjustment after erection and prevent undue strains due to changes in level of the supports, the anchorage at the shore end of each anchor arm is so constructed as to make that end of the bridge adjustable in height within a range of 10 in., and each rocker joining the cantilever arms is adjustable within a range of 2 in.

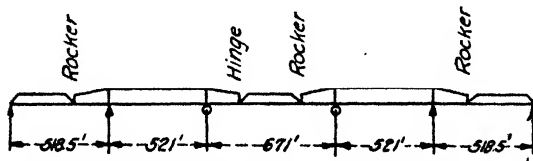

FIG. 12A.—Thebes Bridge over Mississippi River.

The structure illustrated in Fig. 11 has five unknowns and two equations of condition are required. Only one is supplied by the single hinge and the structure is indeterminate.

A different solution would be to make the two intermediate supports fixed and the two end supports expansion, or *vice versa*, and the connection

of the cantilever arms a sliding joint. The same degree of statical indeterminateness would obtain, and stability of each unit would still be preserved.

The bridges illustrated in Figs. 12A and 12B are statically determinate.

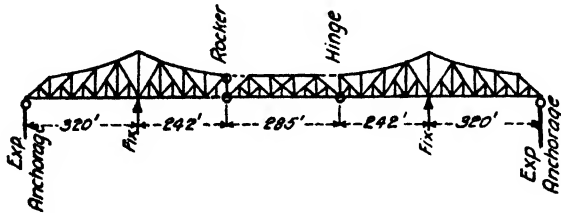

FIG. 12B.—Beaver, Pa., Bridge over Ohio River.

6. Computation for Moments and Shears.—The actual computations for a determinate structure present no difficulty and the position of live load which will give maximum stresses can easily be determined by inspection. The use of influence lines, however, is often valuable.

Illustrative Problem.—Figure 13 shows a typical arrangement. Any load on the anchor arm affects the anchor arm alone and causes $+M$. Any load on the cantilever arm affects the cantilever arm and anchor arm, and causes $-M$. Any load on the suspended span is resolved into reactions which are loads on the

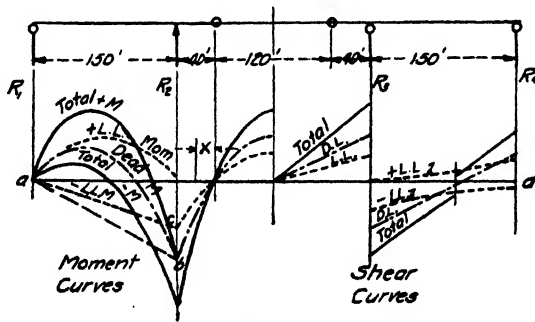

FIG. 13.

cantilever arm. For max. $+M$ in the anchor arm, load the anchor arm only. For max. $-M$, load the suspended span and cantilever arm. All moments on the cantilever arm are negative; load the suspended span and the cantilever arm up to the point in question; other loads are immaterial. For max. $+R_1$, load the anchor arm only; for max. $-R_1$, load suspended span and cantilever arm only. For max. R_2 , use full load. All moments and shears for the suspended span are the same as for any simple span bridge.

Assume a dead load (D.L.) of 5 kips per lin. ft. and live load (L.L.) of 3 kips per lin. ft.

Dead Load Moments.—Maximum D.L. moment suspended span = $\frac{(5)(120)^2}{8}$ = +9,000 kip-ft.

The moment curve will be parabolic with middle ordinate = 9,000 to scale. D.L. moment (dot and dash line) at any point on the cantilever arm:

$$\text{From suspended span, } (5)(60)(X) = -300X \text{ kip-ft.}$$

$$\text{From cantilever arm, } (-5)(X)\left(\frac{X}{2}\right) = -2.5X^2$$

Construct the dot and dash line from the hinge to line of action of R_2 . Maximum M for $X = 40$ is $-16,000$ kip-ft. Lay off $-16,000$ on R_2 to point b and draw the dash line $a-b$.

Maximum $+M$ due to dead load on anchor arm alone = $\frac{(5)(150)^2}{8} = +14,000$ kip-ft. Construct, on line $a-b$, a parabola with vertical (not perpendicular) ordinates whose middle ordinate = $+14,000$ kip-ft. from line $a-b$. The dot and dash line shows the completed D.L. moment curve.

Live Load Moments.—The L.L. moment curve for suspended span and cantilever arm has ordinates = $\frac{3}{5}$ the ordinates of the D.L. moment curve and is shown by dotted lines. Maximum $-M$ at $R_2 = -9,600$ kip-ft. (point c). The $-L.L.$ moment for the anchor arm is a straight line (dotted) from a to c .

Maximum $+M$ due to live load on anchor arm alone = $(\frac{3}{5})(14,000) = +8,400$ kip-ft. Construct a parabola on $a-d$ with middle ordinate of $+8,400$ to scale.

Add algebraically the vertical ordinates from line $a-d$ to the D.L. moment curve and the vertical ordinate from the same line to either curve of L.L. moment to obtain the curves for total $+M$ and total $-M$.

Shears.—For max. $+S$ at any point on the anchor arm, load from R_2 toward R_1 up to the point in question—suspended span and cantilever arm unloaded.

For max. $-S$, load the suspended span and cantilever arm and the anchor from R_1 up to the point in question. All shears on the cantilever arm are positive. Load suspended span and the cantilever arm from the hinge up to the point in question. Other loads are immaterial.

Dead Load Shears.—First determine values of R_1 .

$$(60)(5)(4\frac{1}{2}150) = 80 \text{ (acting down)}$$

$$(40)(5)(2\frac{1}{2}150) = 26\frac{2}{3} \text{ (acting down)}$$

$$(75)(5) = 375 \text{ (acting up)}$$

$$\text{Total } R_1 = 268\frac{1}{3} \text{ kips (acting up)}$$

D.L. shear at any point distant X to left of $R_4 = 268\frac{1}{3} - 5X$. For $X = 150$, $S = 268\frac{1}{3} - 750 = -481\frac{2}{3}$. D.L. shear immediately to left of $R_3 = (12\frac{1}{2} + 40)(5) = +500$. $R_3 = 500 + 481\frac{2}{3} = 981\frac{2}{3}$. D.L. shear curve is shown by dot and dash line.

Live Load Shears.—Maximum $-S$ on the cantilever arm = $\frac{3}{5}$ D.L. shear. Maximum $-S$ on the anchor arm at any point distant X to left of R_4 .

From suspended span and cantilever

$$(12\frac{1}{2})(3)(4\frac{1}{2}150) = -48$$

$$(40)(3)(2\frac{1}{2}150) = \frac{-16}{-64} \text{ kips}$$

$$\text{From anchor arm} = \frac{-3X^2}{(2)(150)}$$

Maximum $+S$ on the anchor arm at any point distant X to left of R_4 (suspended span and cantilever arm unloaded) = $\frac{+(3)(150 - X)^2}{(2)(150)}$. Curves for max. L.L. shear are shown dotted.

The computation for shears at critical points in a cantilever girder bridge is important for determining web shear. If the web shear near the intermediate

reactions is very high, it may be economical to use web reinforcing plates rather than to increase the web thickness throughout the length of the girder, and to provide for longitudinal shear between the web and flange by using shear plates connecting the vertical legs of the flange angles to the reinforced web.

The preceding example assumes uniformly distributed load on the girder as for a deck bridge. If the loads are brought to the girders through floor beams, the moment curves will consist of straight lines between the panel points, and the vertices of the broken line curve will be points on the moment curve as drawn above. The shear curves will be horizontal lines between the panel points.

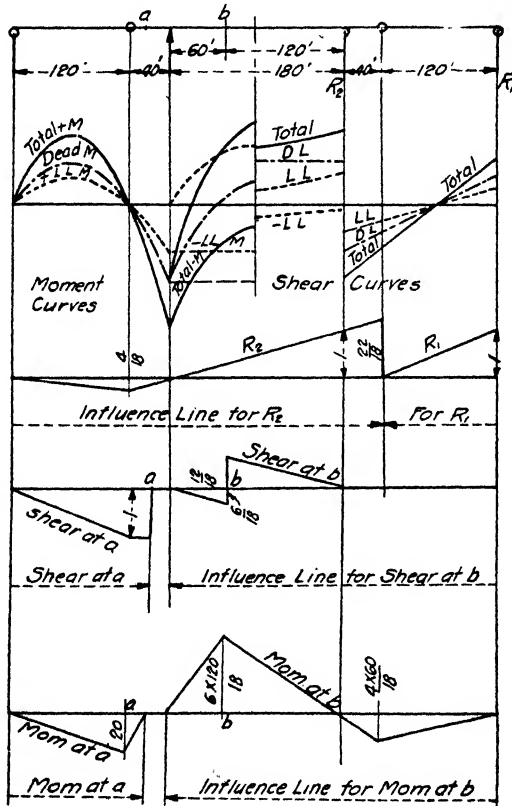

FIG. 14.

Illustrative Problem.—Figure 14 shows the moment curves and typical influence lines for another typical arrangement. In this case max. $-M$ in the intermediate span occurs with both suspended spans and both cantilever arms loaded and intermediate span unloaded. Maximum $+M$ occurs with intermediate span only loaded. The procedure in plotting the curves is so like the preceding example that the computations will not be carried through.

Illustrative Problem.—Figure 15 shows a truss bridge for which the stresses in typical members will be computed. Influence lines for the reactions and for shears and moments at typical points are drawn with their determining ordinates computed and shown in the diagrams. As regards the anchor arm or cantilever arm separately,

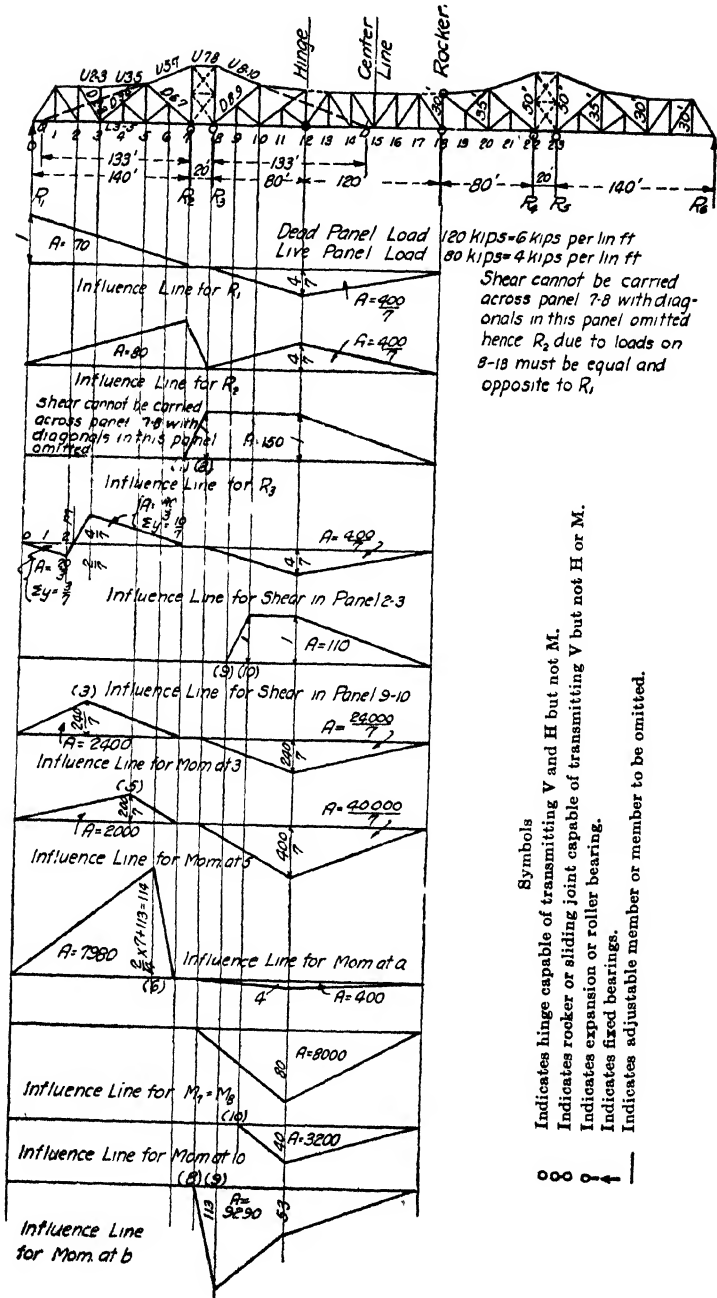

FIG. 15.

the equal and opposite stresses in *U7-8* and *L7-8* are to be regarded as external forces whose moment is equal and opposite to the moment of the other loads and reactions.

For example, using full dead and live load which gives a panel load of 200 kips.

$$R_2 = (7\frac{1}{2})(200) = 1,500 \text{ kips (acting down) which includes full panel load at 8.}$$

$$M_8 = M_7 = (3\frac{1}{2})(200)(80) + (3)(200)(40) = +80,000 \text{ kip-ft. (clockwise).}$$

$$\text{Tension in } U7-8 = \text{compression in } L7-8 = \frac{80,000}{50} = 1,600 \text{ kips.}$$

$$R_1 = \frac{80,000 - (6)(200)(70)}{140} = 28.6 \text{ kips (acting down) which does not include half panel load at } O.$$

$$R_2 = \frac{80,000 + (7)(200)(80)}{140} = 1,371 \text{ kips}$$

(Or, $7 \times 200 - 28.6 = 1,371$) which includes full panel load at 7.

The areas *A* between the influence lines and reference line have been computed and are shown in the diagrams. For example, for shear in panel 2-3, the area *A* from *o* to *m* = $(46\frac{3}{8})(\frac{1}{4}) = 2\frac{3}{8}$; *A*, *m* to 7 = $(93\frac{1}{8})(\frac{3}{4}) = 8\frac{3}{8}$; *A*, 8 to 18 = $(\frac{3}{4})(100) = 40\frac{3}{4}$, and so on.

The sums of the vertical ordinates between the influence line and reference lines below panel points 1 and 2, $(\Sigma y) = \frac{3}{4}$. From *m* to 7, $\Sigma y = 1\frac{1}{4}$.

Assume first a dead panel load of 120 kips = 6 kips per lin. ft. of truss, and live panel load of 80 kips = 4 kips per lin. ft. of truss. Stresses in the members may be computed with equal results by multiplying each panel load by the vertical ordinate beneath the load in the influence diagram and summing, or by multiplying the unit load per lineal foot by the areas in the influence diagram, except in cases like the following: For shear in panel 2-3 in which the influence line intersects the reference line between panel points, use panel loads and vertical ordinates if it is assumed that 3 may be fully loaded while 2 is entirely unloaded. For determining R_1 for loads between 0 and 7, use the uniform load per lineal foot and areas, or deduct one-half panel load from the result obtained by using panel loads and ordinates.

All loads and stresses are in kips (1,000 lb.).

All moments are in kip-ft.

Considering R_1 :

$$\text{D.L. from 0 to 7} = (70)(6) = +420$$

$$\text{D.L. from 8 to 18} = (-40\frac{3}{4})(6) = -343$$

$$\text{Total} = + 77 \text{ kips}$$

$$\text{L.L. from 0 to 7} = +280 \text{ kips}$$

$$\text{L.L. from 8 to 18} = -229 \text{ kips.}$$

Note that R_1 includes one-half panel load at 0.

Considering R_2 :

$$\text{D.L. from 0 to 8} = (80)(6) = 480$$

$$\text{D.L. from 8 to 18} = (40\frac{3}{4})(6) = 343$$

$$\text{Total} = \underline{\underline{823}} \text{ kips}$$

$$\text{L.L. from 0 to 8} = 320 \text{ kips}$$

$$\text{L.L. from 8 to 18} = 229 \text{ kips}$$

Considering R_3 :

$$\text{D.L. from 7 to 18} = (150)(6) = 900 \text{ kips}$$

$$\text{L.L. from 7 to 18} = (150)(4) = 600 \text{ kips}$$

Stress in D2-3.—Vertical component (V.C.) = shear in panel 2-3. D.L. shear in 2-3:

$$(-3\frac{1}{2} + 1\frac{1}{2})(120) - (4\frac{1}{2})(6) = -223 \text{ kips}$$

(Dead load $R_1 = +77$ which includes one-half end panel load. Thus S in 2-3 = $+77 - 60 - 240 = -223$.)

L.L. shear in 2-3:

$$\begin{aligned} (-3\frac{1}{2})(80) - (4\frac{1}{2})(4) &= -263 \\ (+1\frac{1}{2})(80) &= +114 \end{aligned}$$

Total V.C. = -486 kips

$$\text{Stress} = \frac{-486}{90} = -5.4 \text{ kips (compression)}$$

Stress in U2-3 = horizontal component (H.C.) in U3-5. D.L. moment at 3:

$$\left(+2,400 - \frac{24,000}{7}\right)(6) = -6,200 \text{ kip-ft. (counter-clockwise)}$$

L.L. moment at 3:

$$\begin{aligned} (+2,400)(4) &= +9,600 \text{ (clockwise)} \\ \left(-\frac{24,000}{7}\right)(4) &= -13,700 \text{ (counter-clockwise)} \end{aligned}$$

$$\text{Total } M \begin{cases} +3,400 \\ -19,900 \end{cases}$$

$$\text{Stress} \begin{cases} +\frac{3,400}{30} = +113 \text{ kips (compression)} \\ -\frac{19,900}{30} = -663 \text{ kips (tension)} \end{cases}$$

Stress in L3-5.—Take section in panel 3-4 with center of moments at 5 in upper chord. Find M_5 . Note that M_5 obtained from the influence diagram includes the M of all forces to one side of 5. Since the moment of all forces to left of 4 is desired the moment of panel load at 4 must be subtracted algebraically from M_5 obtained from the diagram.

D.L. moment:

$$\begin{aligned} \left(+2,000 - \frac{40,000}{7}\right)(6) &= -22,270 \\ \text{Moment due to } P_4 &= -(-120)(20) = +2,400 \\ \text{Total} &= -19,870 \text{ kip-ft.} \end{aligned}$$

L.L. moment:

$$\begin{aligned} (+2,000)(4) - (-80)(20) &= +9,600 \text{ kip-ft.} \\ \left(-\frac{40,000}{7}\right)(4) &= -22,860 \text{ kip-ft.} \end{aligned}$$

$$\text{Total } M = -42,700 \text{ kip-ft.} \quad \text{Stress} = \frac{42,700}{35} = 1,220 \text{ kips (compression)}$$

Stress in D6-7.—Find moment about a .

D.L. moment:

$$(7,980 - 400)(6) = +45,480 \text{ kip-ft.}$$

L.L. moment:

$$\begin{aligned} (+7,980)(4) &= +31,920 \text{ kip-ft.} \\ (-400)(4) &= -1,600 \text{ kip-ft.} \end{aligned}$$

Total $M = +77,400$ kip-ft.

$$\text{V.C. stress in D6-7} = \frac{77,400}{133} = 581 \text{ kips (compression)}$$

Or V.C. maximum compression in $D6-7 = R_2 - \text{V.C. in } U5-7$ with live load from 0 to 7. Note that R_2 includes panel load at 7 which does not affect $D6-7$.

$$\text{V.C. in } U5-7 \text{ dead load only} = \frac{(8,000)(6)}{50} \left(\frac{15}{40} \right) = 360.$$

$$R_2 \text{ for D.L.} = 823 - 120 = 703$$

$$R_2 \text{ for L.L.} = 320 - 80 = 240$$

$$\text{Total} = 943 \text{ kips}$$

$$943 - 360 = 583 \text{ V.C.}$$

$$\text{Stress} = (583) \left(\frac{5\frac{3}{8}}{35} \right) = 882 \text{ kips (compression)}$$

Stress in $U7-8 = \text{H.C. in } U5-7 = \text{H.C. in } U8-10$. Find $M_7 = M_8$.

$$M = (8,000)(10) = 80,000 \text{ kip-ft.}$$

$$\text{Stress} = \frac{80,000}{50} = 1,600 \text{ kips (tension).}$$

Stress in $L7-8$ is equal and opposite to stress in $U7-8$.

Stress in $L8-10$.—Take section in panel 8-9 with center of moment at 10. Live load 10 to 18. Add the effect of dead panel load P_9 to M_{10} obtained from the diagram

$$\text{Stress} = \frac{(-3,200)(10) + (120)(20)}{35} = -845 \text{ kips (compression)}$$

Stress in $D8-9$.—From diagram for moment at b .

$$\frac{(-9,290)(10)}{133} = -698 \text{ V.C.}$$

$$\text{Stress} = (-698) \left(\frac{5\frac{3}{8}}{35} \right) = -1,056 \text{ kips (compression).}$$

Stresses in the suspended span are the same as for a simple span bridge.

The method of procedure for finding stresses for wheel concentrations is the same as for a simple structure and the influence line diagram will assist in finding the

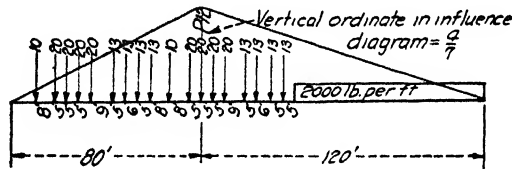

FIG. 16.

position of the loads which will give maximum stress. For example, to find the maximum compression in $D2-3$ of Fig. 15 use the wheel loads on 8-18 with the heaviest loads near 12, and uniform load in 0- m . The position of wheel loads which will give maximum stress is such that the average load per foot in 8 to 12 will be as nearly as possible equal to the average load per foot in 12 to 18. For this position, find the moment M at 12 as for a simple span 8 to 18. Then the vertical component of the stress in $D2-3$ will be $\frac{1}{8}M$. (The moment due to load unity at 12 would be $\frac{(80)(120)}{200} = 48$, while the vertical component of the stress is $\frac{1}{8}$. Therefore, actual stress : $M :: \frac{1}{8} : 48$, or actual stress = $\left(\frac{4}{7} \right) \left(\frac{M}{48} \right) = \frac{1}{84} M$).

The stress may also be found by finding the summation of the products obtained by multiplying each load by the vertical ordinate in the influence diagram under the load.

Assume Cooper's E-40 followed by a train load of 4,000 per lin. ft. (2,000 on each truss), as shown in Fig. 16.

With P_{11} on 8-12 the average load on 8-12 is $17\frac{2}{3}\%$ = 2.15 and average load on 12-18 is $\frac{112 + (2)(75)}{120}$ = 2.18.

With P_{12} on 8-12 average load on 8-12 is $19\frac{2}{3}\%$ = 2.4 and average load on 12-18 is $\frac{92 + (2)(80)}{120}$ = 2.1.

Place P_{12} at 12.

Using moment diagram, $R_1 = 227.4$ and $M_{12} = 11,485$.

V.C. of stress in $D2-3$ due to loads on 8-18 is $\frac{11,485}{84} = 137$.

Check this result by using ordinates in the influence diagram

$$\begin{aligned} \left(\frac{11}{80}\right)\left(\frac{4}{7}\right)(10) &= 0.8 \\ \left(\frac{26.5}{80}\right)\left(\frac{4}{7}\right)(80) &= 15.1 \\ \left(\frac{51}{80}\right)\left(\frac{4}{7}\right)(52) &= 19.0 \\ \left(\frac{67}{80}\right)\left(\frac{4}{7}\right)(10) &= 4.8 \\ \left(\frac{75}{80}\right)\left(\frac{4}{7}\right)(20) &= 10.7 \\ \left(\frac{115}{120}\right)\left(\frac{4}{7}\right)(60) &= 32.9 \\ \left(\frac{93}{120}\right)\left(\frac{4}{7}\right)(52) &= 23.0 \\ \left(\frac{40}{120}\right)\left(\frac{4}{7}\right)(2)(80) &= 30.5 \end{aligned}$$

136.8 check

The preceding problem illustrates fully the use of influence lines, but to the computer familiar with cantilever bridges purely arithmetical methods of computation are just as convenient.

The arrangement illustrated in Fig. 15 requires wide piers for the supports at 7-8 and at 22-23 but makes for economy in the superstructure. It is, therefore, adapted to cases in which the piers are of short height with shallow foundations.

The arrangement illustrated in Fig. 13 permits narrow piers to support single reactions; but for the same total span requires more steel in the superstructure than for the arrangement in Fig. 15. It is, therefore, better adapted for cases which require high piers or deep foundations.

7. Reactions for an Indeterminate Cantilever Bridge.—The computations for an indeterminate cantilever bridge are as simple as for a determinate structure once the reactions have been found. The method of finding the reactions for the type illustrated in Fig. 11 is as follows:

Let Δp = deflection at b due to P at any point in $a-b$.

δ_1 = deflection at b of $a-b$ due to unit load at b .

δ_2 = deflection at b of $b-c$ due to unit load at b .

R_b = reaction at b assumed upward on $a-b$.

With respect to $a-b$, deflection at $b = \Delta p - R_b \delta_1$

With respect to $b-c$, deflection at $b = R_b \delta_2$

Therefore

$$\Delta p - R_b \delta_1 = R_b \delta_2$$

or

$$R_b = \frac{\Delta p}{\delta_1 + \delta_2}$$

8. Erection of Cantilever Bridges.—Cantilever truss bridges may be erected with falsework under the main spans only, that is, under the anchor arms or the intermediate spans. The cantilever arms and the suspended spans may be erected by building out panel by panel from the anchor arm or the intermediate spans, the suspended spans being made temporarily continuous with the anchor arms or intermediate spans and after erection converted into simple spans by making the proper members adjustable.

For example, in Fig. 15, $U12-13$ is a member, during erection, of the cantilever consisting of the left cantilever arm and left semi-truss of the suspended span, and $U17-18$ and $L18-19$ are members, during erection, of the cantilever consisting of the right cantilever arm and right semi-truss of the suspended span. After the semi-trusses are joined, these members are made self-adjusting to expansion and contraction by means of sliding joints and carry no dead or live load stress. They may be used, however, as part of the lateral systems to carry wind loads. In dimensioning the suspended span of important structures, exact measurements must be obtained by triangulation, checked if possible by direct measurement, of the distance between the ends of the cantilever arms, corrected for strain due to the weight of the suspended span and estimated temperature at the time of joining the semi-trusses. Special means of erection adjustment are provided as illustrated in Art. 9. When the suspended span is swung, reversal of dead load stress takes place in the chords of the suspended span, and the dead load stresses in the cantilever and anchor arms due to the suspended span are reduced.

The cantilever method of erection is the usual method, but in a few cases (the Quebec Bridge and Highland Park Bridge, Pittsburgh, for example) the suspended span has been assembled in the field or on barges, floated into place and hoisted bodily into position.

9. Special Details.

9a. Erection Adjustments.—Erection adjustments are needed when the cantilever method of erection of the suspended span is used and afford control of the position of the ends of the semi-trusses both vertically and horizontally, and allow the last members erected to be brought together and connected. The top chord adjustments are always made in the members corresponding to $U12-13$ and $U17-18$, of

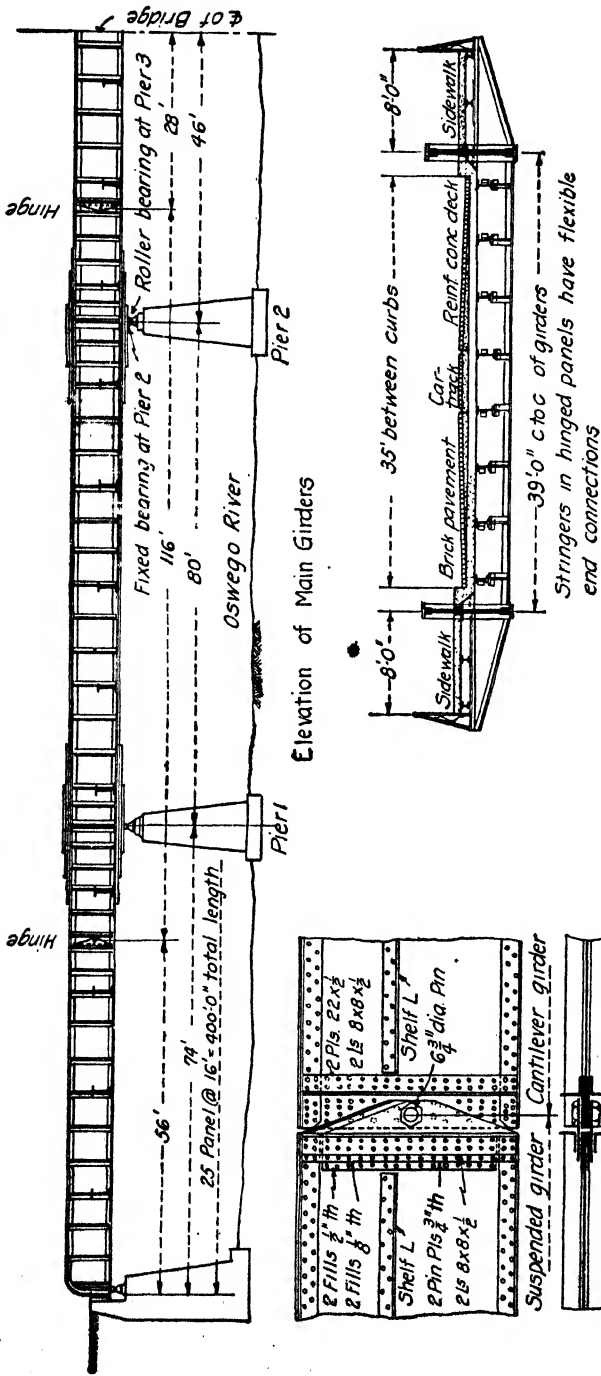

Fig. 17.—General drawing of cantilever bridge at Salamanca, N. Y.

Fig. 15, which are in tension during erection, and the bottom chord adjustments in the bottom chord members corresponding to L11-12 and L18-19 of Fig. 15 which are in compression during erection. The temporary adjusting apparatus is placed near a panel point.

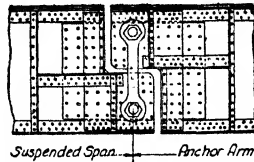

FIG. 18.—Typical detail of eye-bar rocker for girder.

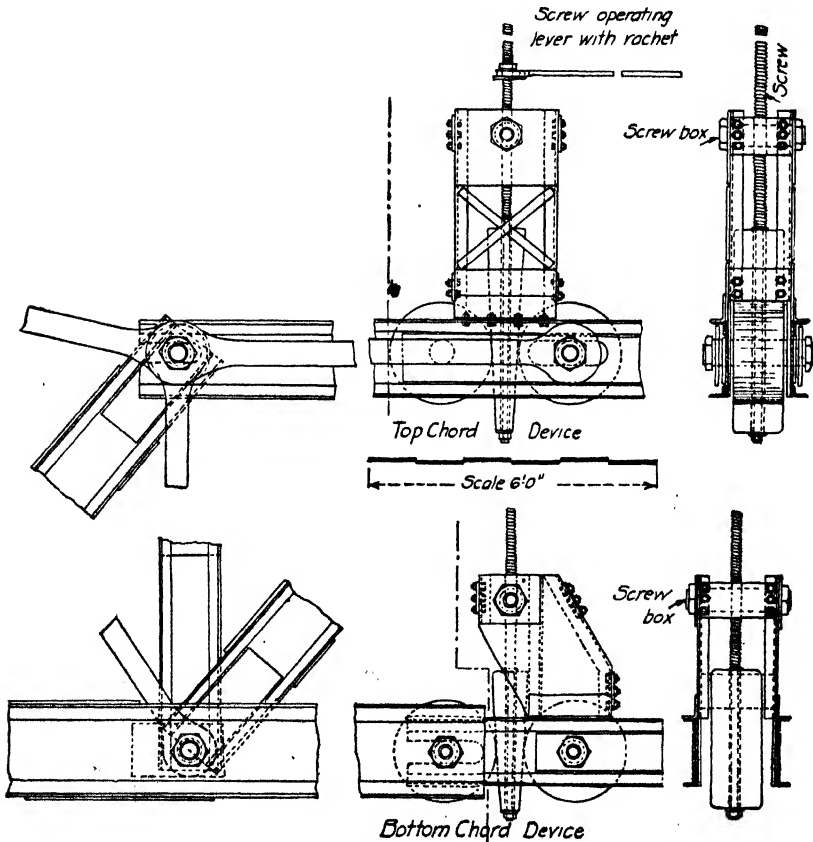

FIG. 19.—Erection adjustment, Cincinnati-Newport Bridge.

Figure 19 shows the erection adjustment device of the Cincinnati-Newport Bridge. The adjustable top chord member is slotted at its end around the truss pin and around the pin of the right roller; thus being held in position vertically and laterally while permitting longitudinal

expansion. The left roller is attached by its pin to the chord. A short temporary eyebar connects the right roller, which is unconnected to the chord itself, to the truss pin at the panel point. The wedge between the rollers, when moved down by its operating screw, separates the rollers and draws the panel points corresponding to *U17* and *U18* of Fig. 15 together; and when moved upwards allows these panel points to separate. The rollers of the bottom chord adjusting device are attached directly

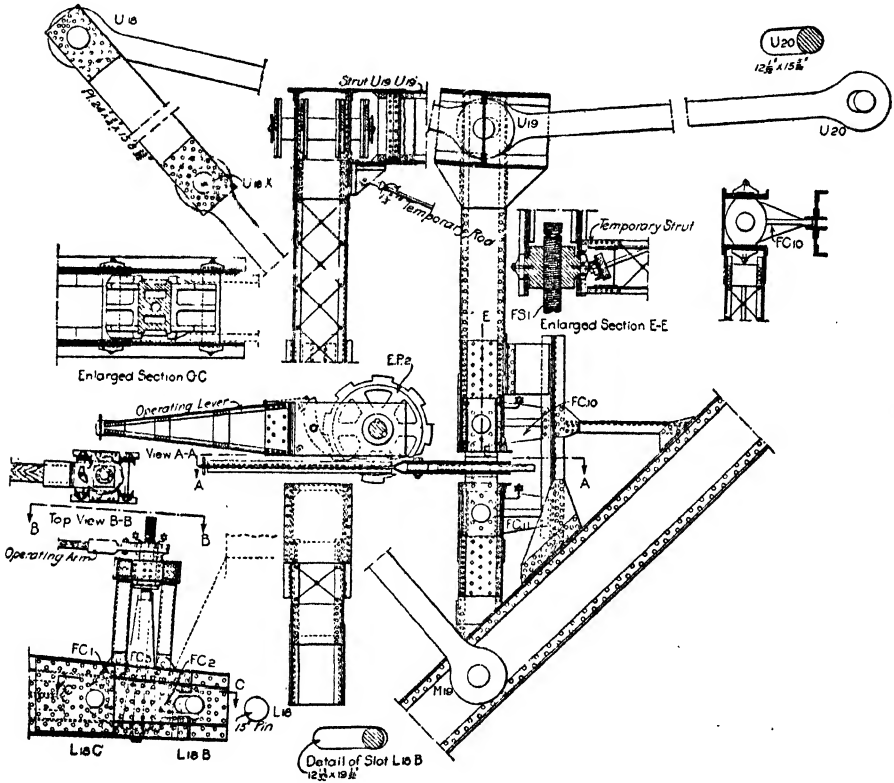

FIG. 20A.—Erecting adjustment devices, Beaver Bridge.

to different sections of the bottom chord; one section of the chord being slotted around the pin of the roller attached to the other section. Lowering the wedges separates the rollers and drives apart the panel points corresponding to *L18* and *L19* of Fig. 15. Raising the wedges allows these panel points to draw together. In practice the adjustments are usually so made at the beginning of erection of the suspended span, that the outer ends of the semi-trusses will require only to be lowered by releasing the adjusting apparatus. After erection, the temporary eyebars, frames, wedges and rollers may be removed, leaving the proper chord.

members self-adjusting to expansion. The apparatus described above gave entire satisfaction.

The erection adjustment device of the Red Rock cantilever bridge in California is the same in principle, but the wedges bore against sliding surfaces instead of rollers.

In the Beaver Bridge the bottom chord was adjusted by means of a wedge device and the top chord by a semi-toggle operated by a sort of

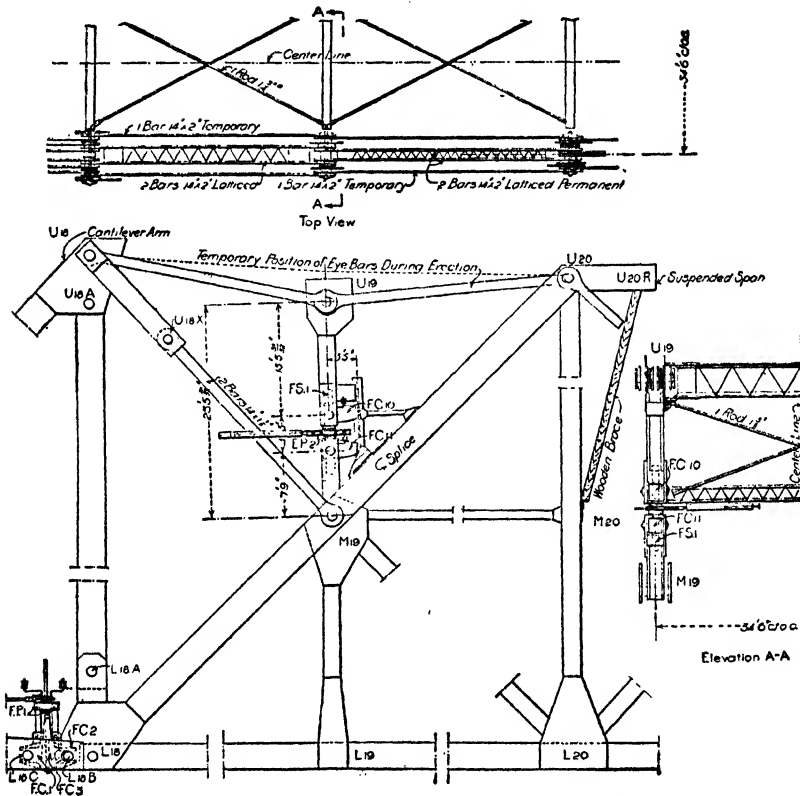

FIG. 20B.—Arrangement of temporary members for erection adjustment, Beaver Bridge.

turnbuckle arrangement (Fig. 20A and 20B). The same device was used for the Sewickley and Monongahela bridges. At the beginning of erection, the wedges and toggles were so set that no further extension was needed and the final adjustment required was only the lowering of the ends of the semi-trusses by releasing the wedges and toggles in order to make the final connections.

In large bridges other erection adjustments are required in order to make connections at the panel points under varying conditions of erection

stresses. A description of the devices used for the Monongahela Bridge is contained in the *Engineering Record*, April 9, 1904.

9b. Anchorages.—Anchorages at the shore ends of the anchor arms usually consist of eyebars extending down into the abutments and attached to girder platforms embedded in the masonry.

The anchorage for the Monongahela Bridge, Pittsburgh, is shown in Figs. 21 and 22. The reaction girders are embedded in the pier 50 ft. below the top and have a full capacity of 1,500,000 lb. resistance to uplift which is 75 per cent in excess of the computed maximum uplift. The 30-ft. eyebars connected to the reaction girders engage with the 30-ft.

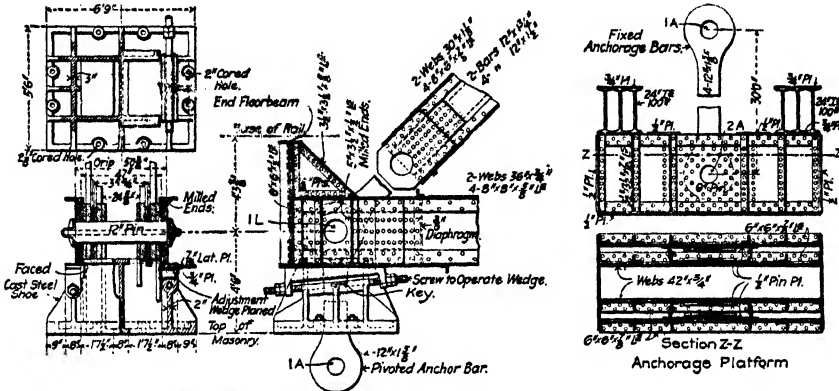

Connections on Anchor Pier

Fig. 21.—Anchorage details, Monongahela Bridge.

eyebars connected to the end of the anchor arm. The anchor end of the truss bottom chord has bearing plates riveted thereto which bear on the top flanges of the cast steel pedestals. They are locked over the pedestals and are adjusted by means of the screws so as to bring the end pin to exact bearing in the loaded anchor bars and allow for inaccuracies in masonry work and setting of the reaction girders.

The anchorage adjustment of the Beaver Bridge is shown in Figs. 23 and 24. This provides adjustment for stretch in the anchorage eyebars. The computed end reaction changes under live load from 2,100,000 lb. positive to 2,300,000 lb. uplift. Wedges are provided between the cast steel blocks which engage the anchorage eyebars within the shoe, and the inclined wedge-seats in the shoes. These wedges were driven when the eyebars were under maximum stress which prevented subsequent shortening of the eyebars under reduced load.

The stress in the eyebars being constant, the shoes are drawn tight to the bridge seat under all conditions of uplift. The anchor eyebars connecting the embedded reaction girders and anchorage bearings on top of the pier, are fixed; provision for expansion being made through the

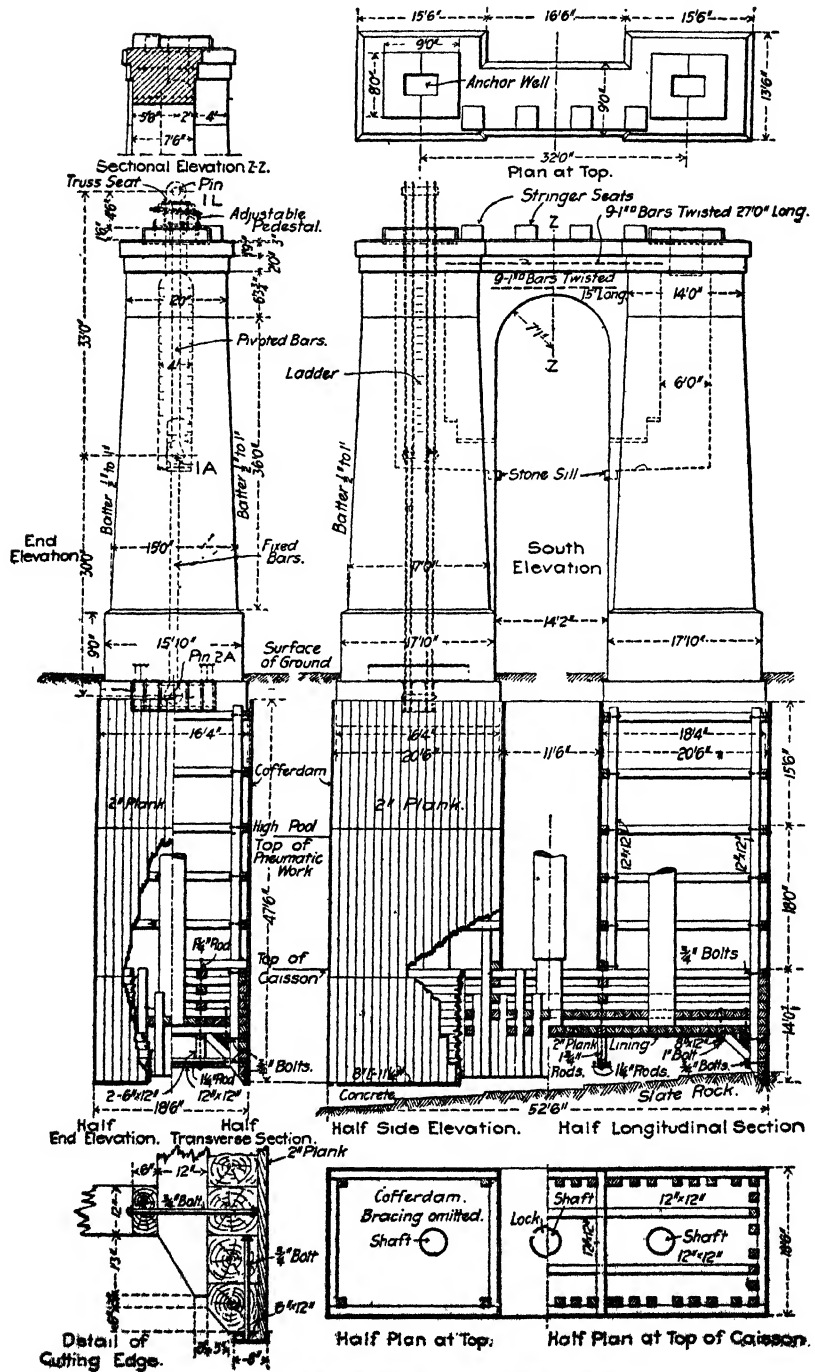

FIG. 22.—Anchor pier, Monongahela Bridge.

built-up rockers, 5 ft. long, connecting the anchor arm to the anchorage bearing.

The total computed expansion due to temperature and strain is about 7 in and the 100,000-lb. longitudinal thrust due to the maximum inclina-

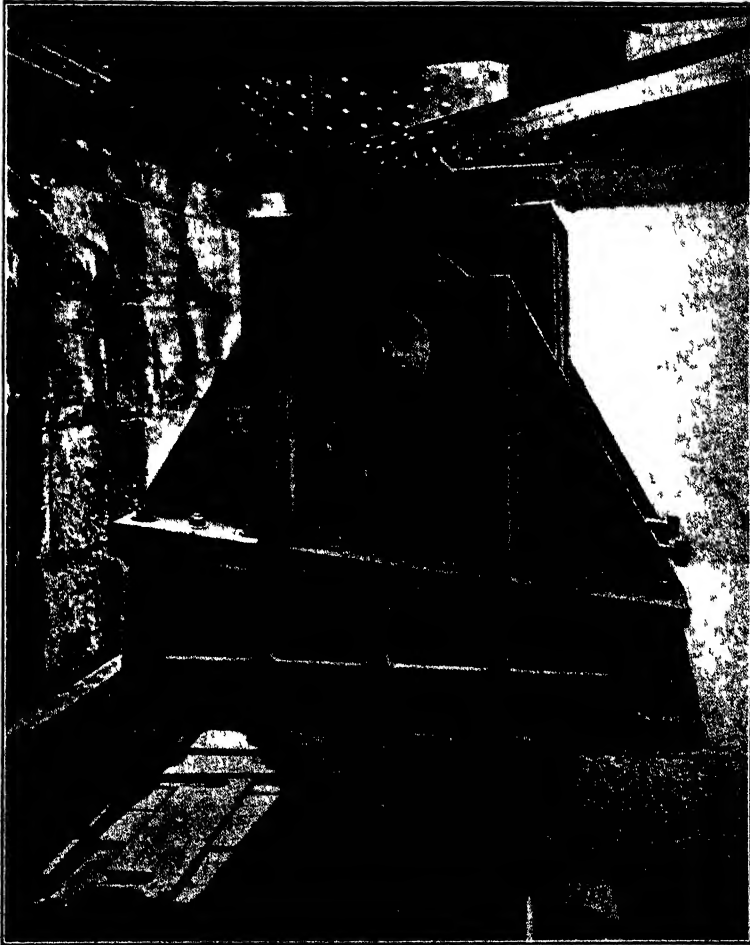

FIG 23 — One of the anchorage bearings of the Beaver Bridge

With crosshead block at upper end of anchorage eyebars, wedge adjustment under block to hold eyebars in maximum tension, and rocker connection from block to end pin of bridge. The bearing takes no wind reaction, this being carried to a special wind abutment at middle of end floor beam.

tion of the rockers is taken up within the shoe itself and prevented from affecting the anchorage eyebars by shaping the ends of the eyebar blocks as slides fitted into guide jaws formed by the outer webs of the shoes.

In the Sewickley Bridge, Pittsburgh, the anchorage arrangement is similar to that of the Beaver Bridge, except that adjustment for stretch

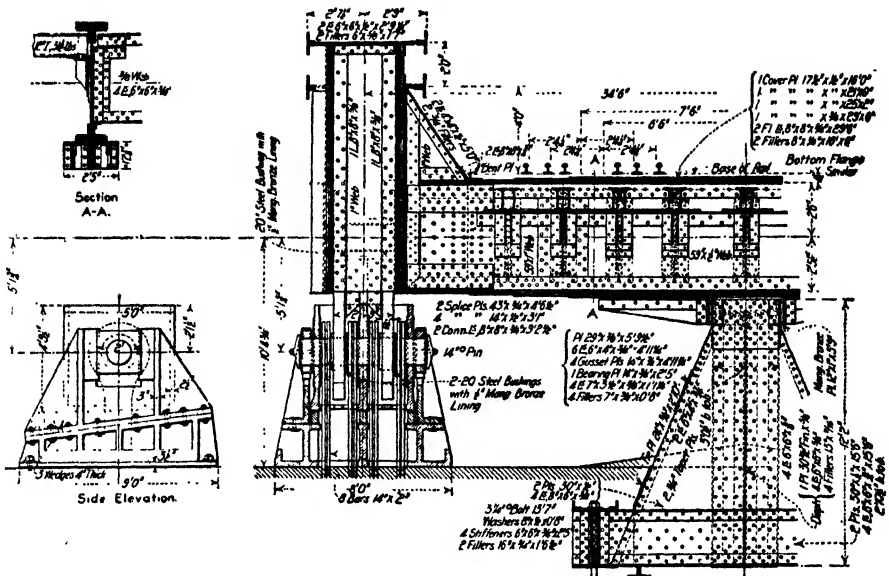

FIG. 24.—Anchorage bearing and wind abutment of Beaver Bridge.

Longitudinal expansion movement of the bridge is allowed for in the anchorage bearing by means of the rocker connecting the pin LO to the crosshead block, and at the wind abutment by a sliding joint lined with manganese bronze bearing plates.

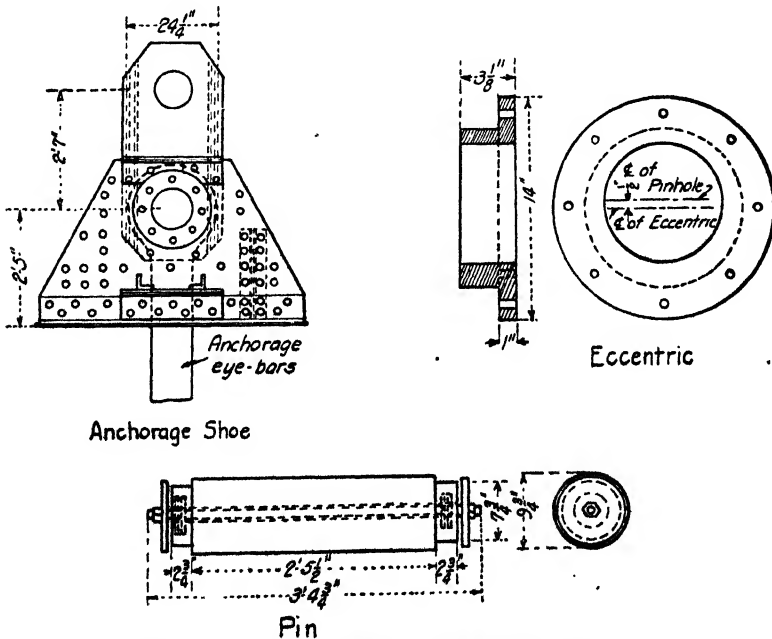

FIG. 25.—Anchorage adjustment, Sewickley Bridge.

in the anchor eyebars is made by means of an eccentric instead of by wedges. The $9\frac{3}{4}$ -in. pins taking the lower ends of the short rockers are turned to $7\frac{3}{4}$ in. at the webs of the shoes and pass through flanged steel sleeves seated on the webs of the shoes. The $7\frac{3}{4}$ -in. pin holes in the sleeves are $\frac{1}{2}$ in. eccentric with the outer circumference of the sleeves, and, by turning the sleeves, 1-in. adjustment of the pin is obtainable (Fig. 25). Final adjustment was made under maximum strain in the eyebars.

9c. Lateral Systems.—The top lateral system of the suspended span may end at portals between the end posts, and the wind loads transferred to the bottom lateral system of the cantilever arm; or the top lateral loads may be transferred to the top lateral system of the cantilever arm and carried through this system to portals between the long diagonals corresponding to *D8-10* and *D20-22* of Fig. 15 and thence to the piers. In the former case, there are no laterals in the end panels (12-13 and 17-18 of Fig. 15) of the suspended span. In the latter case special details are required to transfer the wind loads past the sliding joints in the adjusting top chord members in the end panels of the suspended span (*U12-13* and *U17-18* of Fig. 15). Likewise, special details are required to transfer the bottom lateral loads past the sliding joints in the adjusting bottom chord members in the last panels of the cantilever arms (*L18-19* of Fig. 15).

Figure 26 shows the bottom lateral transfer of the Thebes Bridge. The cantilever span lateral system ends at the floor beam (which is the lateral strut of the system) near the sliding joint and the suspended span lateral system ends at the other side of the joint; there being an independent strut to hold the two chords in position, which was placed after the erection of the superstructure. The sliding joint is made with a clearance of $\frac{1}{32}$ in., but the link arrangement (devised by Ralph Modjeski) transmits wind shearing forces without developing bearing in the joint itself.

In this bridge the top lateral system of the suspended span ends at portals between the end posts which transfers the load to the bottom lateral systems of the cantilever arm. The top chord member in the end panel of the suspended span is therefore a dead member after erection and the joint is simply an oblong pin hole.

In the Inter-provincial Bridge over the Ottawa River, Ottawa, Can., the top lateral loads of the suspended span are transferred to the top lateral system of the cantilever arm; and the end sections of the top chords of the suspended span to which the suspended span laterals are riveted, are fitted to slide longitudinally with finished bearings between the jaws of the members corresponding to *U12-13* and *U17-18* of Fig. 15. The transverse struts and diagonals of the cantilever arm lateral system extending toward the piers are riveted to these members.

The wind transfer details of the Beaver Bridge are shown in Figs. 27 and 24. In this bridge both the top and bottom lateral loads of the suspended span are transferred respectively to the top and bottom lateral systems of the cantilever arm, without preventing free longitudinal motion between the suspended span and the cantilever arm and all lateral loads are transferred to the end abutments by means of wind pedestals which engage the end floor beams at their centers by means of

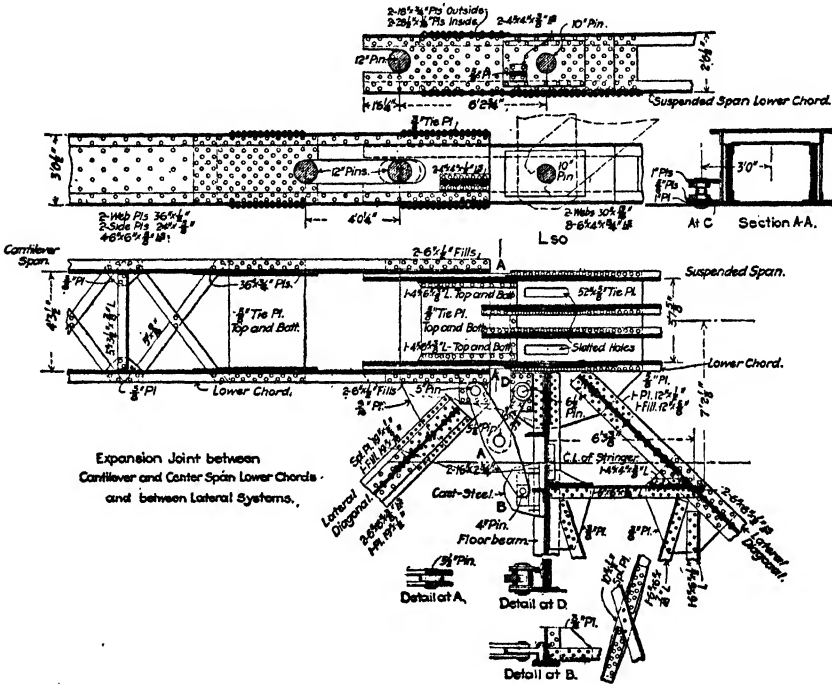

Fig. 26.—Expansion joints in main span of Thebes Bridge.

longitudinally sliding joints lined with manganese bronze. The suspended span top lateral system ends at the hip joint with a transverse strut. The top lateral system of the cantilever arm ends at the middle of this strut and is provided with a longitudinally sliding joint between guide jaws on the strut, the jaws being lined with manganese bronze. The eyebars comprising the top chord corresponding to U12-13 and U17-18 of Fig. 15 which were used as erection members are laed together to form stiff members of the lateral system.

9d. **Stringer Expansion Bearings.**—The stringers require expansion bearings at one end in the last panel of the cantilever arm. They are usually made by allowing one end of the stringer to slide in pockets, as seen in Fig. 27.

The tower pier bearing for the Beaver Bridge is shown in Fig. 28. The center of the bed of rollers is on the bottom chord center line and thus permits rotation of the joint and eliminates secondary bending stresses due to truss deformation. The bearing is not an expansion bearing properly so-called.

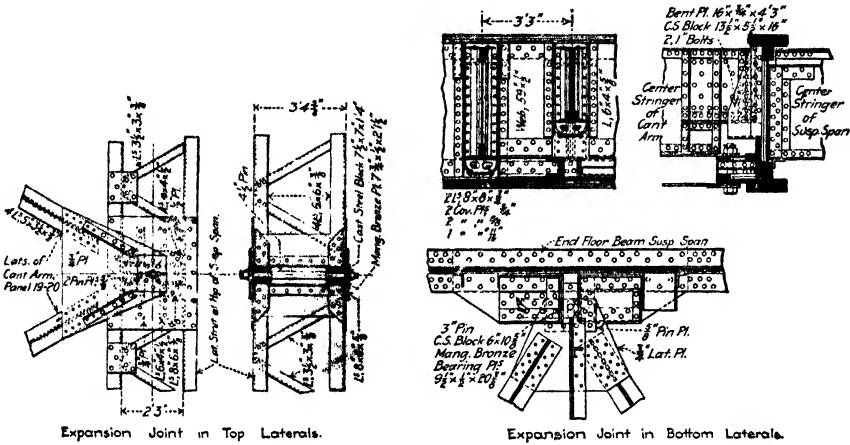

FIG. 27.—Wind-transfer details at end of suspended span, Beaver Bridge.

10. Economy.—Theoretical discussions have been advanced purporting to show that, aside from the question of falsework costs, the cantilever bridge has in general no economic advantage over a bridge of the same size consisting of simple spans, if the conditions are such that the piers may be located with equal economy in any position. But the elements entering into the problem are too many to be expressed in a formula and the deductions from such theoretical discussions are likely to be erroneous. The economic advantage of the cantilever design in a particular case is, however, partly offset as a result of the practice of increasing the sectional areas of members subject to reversal of stress under live load, on account of such reversal. The practice referred to is a relic of the now obsolete practice of reducing the allowable unit stresses in members subject to change of stress even of like kind (the reduction being a function of the maximum and minimum stresses) and should be discarded. It is entirely reasonable to design members for the maximum stress of either kind without reduction of unit stresses on account of reversal.

The cantilever principle has been used to advantage even for small bridges where simple spans would ordinarily be used. One instance will be cited, namely the cantilever girder bridge at Salamanca, N. Y., details of which are shown in Fig. 17.

	Cantilever bridge	Simple span bridge
Girders 455,000 lb. at 3¾ cts.....	\$17,100
Girders 355,000 lb. at 3¾ cts.....	\$13,300	
4 piers at \$3,800 each	15,200
4 piers at \$3,500 each	14,000	
	<u>\$27,300</u>	<u>\$32,300</u>

The foregoing comparison is based on very low contract prices; at ordinary prices the economic advantage of the cantilever would be greater. The total cost of this structure was about \$80,000.

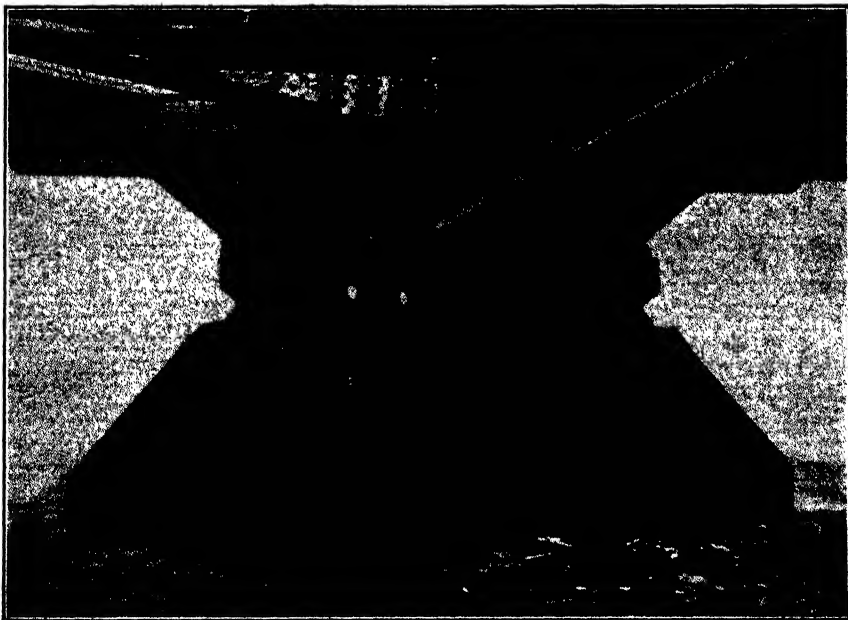

FIG. 28A.—Tower pier bearing, Beaver Bridge.

11. Relative Rigidity.—The simple span structure possesses a theoretical advantage over the cantilever in point of rigidity. Actual cantilever bridges show, however, no lack in this regard under all conditions of traffic and the designer should not hesitate to take advantage of any economy shown by comparative designs.

12. Economical Ratios of Span Lengths.—In cases where the location of the piers is not more or less fixed by the ground contour or other restrictions, the relative lengths of the anchor arm or intermediate

span, the cantilever arm, and the suspended span necessary to obtain maximum economy, must be decided. The economic ratios of lengths will differ for different ratios between dead and live load. For any particular case it may be assumed, in making a first approximation, that the material in the trusses or girders is proportional to the areas of the moment diagrams. Having selected a few arrangements that look reasonable, the curves of total moment for the assumed dead and live loads should be plotted. That arrangement which has the least total moment area may be selected as the basis of making preliminary designs and estimates to determine the correct ratios of lengths.

It will sometimes be of advantage to increase the lengths of the anchor arms and decrease those of the cantilever arms in order to avoid using anchorages.

13. Miscellaneous Data.—The following table gives the span lengths of several bridges which are all of the type of the Beaver and Monongahela Bridges:

	Each of 2 anchor arms	Each of 2 cantilever arms	Suspended span	Total length main spans only
Monongahela.....	346	226	360.0	1,504.0
Beaver.....	320	242	285.0	1,409.0
Sewickley.....	300	200	350.0	1,350.0
Mingo Junction.....	298	195	310.5	1,296.5
Cincinnati-Newport.....	250	156	208.0	1,020.0
Burlington, Iowa.....	260	132	216.0	1,000.0

The following data of quantities (structural steel only) in the main spans, omitting approach spans, gives an idea of the magnitude of typical cantilevers:

Beaver.—Two-track railroad bridge 34 ft. 6 in. center to center of trusses.

Anchor and cantilever arms, 1,124 ft.

Trusses, bracing, bearings, anchorages..... 21,000,000

Floor..... 3,500,000

24,500,000 lb.

Suspended span, 285 ft.

Trusses and bracing..... 2,220,000

Floor..... 875,000

3,095,000 lb.

Sewickley.—Highway and electric railroad bridge, 32 ft. center to center of trusses.

Anchorage.....	93,000 lb.
Anchorage arms including tower posts.....	4,430,000 lb.
Cantilever arms.....	2,545,000 lb.
Suspended span.....	1,805,000 lb.

Memphis.—One-track railroad and highway bridge, 30 ft. center to center of trusses.

Anchor span, 226 ft.....	1,607,000 lb.
Cantilever span, 169 ft.....	1,252,000 lb.
East suspended span, 452 ft.....	2,330,000 lb.
Cantilever arm, 169 ft.....	1,285,000 lb.
Intermediate span, 621 ft.....	5,122,000 lb.
Cantilever arm, 169 ft.....	1,260,000 lb.
West suspended span, 452 ft.....	2,328,000 lb.

The steel in the main spans of Thebes Bridge weighed about 28,000,000 lb.

The steel in the Monongahela Bridge weighed about 14,000,000 lb.

The steel in Mingo Junction Bridge weighed about 12,000,000 lb.

The diagram, Fig. 29, shows the comparative lengths (main spans only) of typical large American cantilever bridges.

Note the various types of web systems. The "K" system, used in the Quebec Bridge, or the double Warren system used in the Memphis Bridge (also Cernavoda Bridge, Fig. 36), gives less distortion and smaller secondary stresses than the usual subdivided Pratt system.

14. Arched Cantilever Bridges.—Strained attempts to disguise the true character of a structure should never be made. Most attempts at disguise end in failure and show poor judgment and bad taste. Such bridges as the Quebec (Fig. 29), Cernavoda¹ (Fig. 36), Monongahela (Fig. 29) and Red Rock (Fig. 33) are pleasing structures, because their true nature is expressed. The Jubilee Bridge,² Calcutta, India, on the other hand, is not a success esthetically because the camel-back truss supported at intermediate points does not carry out the cantilever idea suggested by the relationship between substructure and superstructure (Fig. 31). Cantilever bridges can, however, be built on arch outlines with good effect and at the same time conform to structural requirements. The cantilever principle gives a correct solution in cases where arches suit the topography but where proper foundations for true arches are secured with difficulty.

The Arroya Del Chico railroad bridge Mexico (Fig. 30) is a deck truss bridge built over a deep gorge and consists of two anchor arms of 105 ft. each, two cantilever arms of 135 ft. each, and a suspended span of 120 ft. The top chord is horizontal. The bottom chords of the anchor arms are circular segments and the bottom chords of the cantilever arms and

¹ See *Eng. News*, Aug. 27, 1896 and *R. R. Gazette*, Nov. 29, 1895.

² See *Eng. Record*, Oct. 4, 25, 1890.

suspended span form a circular segment. The depth at the piers between anchor arms and cantilever arms is 63 ft. The structure as a whole presents the appearance of a spandrel braced arch with two semi-arch approach spans.

The gorge is through solid rock and a better solution would have been to make the center span a true arch which could have been erected by the

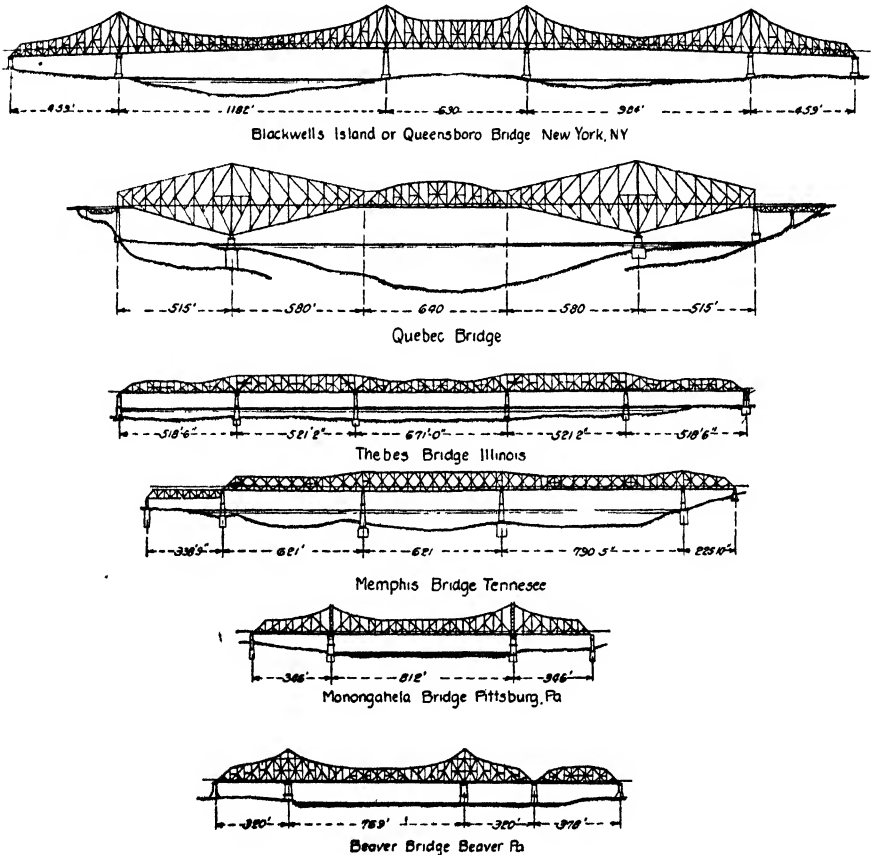

FIG. 29.—Outlines of large American cantilever bridges.

cantilever method, and, after joining at the center, have supported live loads by arch action. Or, the suspended span could have been omitted and the cantilever arms extended and connected by a sliding joint, the structure being partially continuous. Several so-called balanced cantilevers, both steel and reinforced concrete girders, have been built on the latter principle to give the appearance of arches when the foundations were not suitable to support true arched bridges.

Davis Avenue Bridge, Allegheny, Pa., is another example of a cantilever built on the lines of a spandrel braced arch. The bridge is over a deep ravine and consists of two anchor arms, 95 ft. each, two pier panels 25 ft.

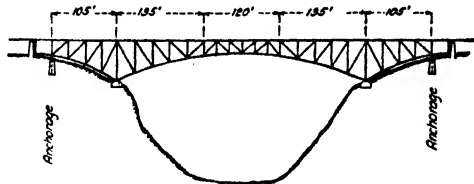

FIG. 30.—Arroya Del Chico Bridge, Mexico.

each, two cantilever arms 39 ft. each and a 78-ft. suspended span. The depth over the piers is 55 ft. The top chord is horizontal (the bridge being a deck structure) and the bottom chords form circular segments as in the Arroya Del Chico Bridge.

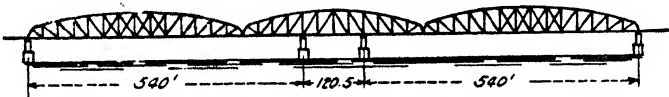

FIG. 31.—Jubilee Bridge over Hooghly River, Calcutta, India.

Riverside Drive viaduct over 96th Street, New York City, is a cantilever built on the lines of an arch with suspended span omitted. This is a deck steel structure supported on steel columns at the curbs with masonry anchor piers beyond the sidewalks. The anchor arms, about 20 ft. each,



FIG. 32.—Pont de Frans, sur la Saône a Ville-franche, France.

span the sidewalks and the cantilever arms about 35 ft. each, join over the center line of the street. The cantilever design was adopted because the cost of foundations suitable for a masonry arch would have been excessive.

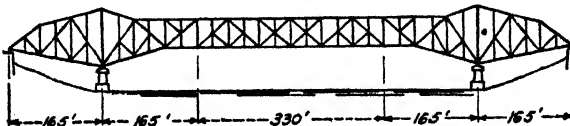

FIG. 33.—Red Rock Bridge, California.

The Passy Bridge over the Seine River, France, is a beautiful structure, comprising anchor, cantilever and suspended spans, and resembles a series of flat arches with semi-arch approach spans. The narrow portions between chords have solid webs with arched spandrel openings.

15. Some Esthetic Considerations.—The Pont de Frans¹ over the Saone River, France, is one of the most beautiful examples of a cantilever structure, exhibiting extreme grace of outline while conforming to structural requirements (Fig. 32). In contrast to this is the Jubilee Bridge (Fig. 31) which is, taken as a whole, discordant, although the trusses have graceful outlines. The Red Rock cantilever (Fig. 33) lacks the graceful

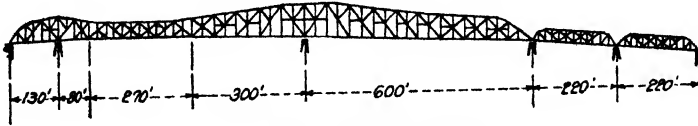

FIG. 34.—Marietta Bridge.

curves of the Pont de Frans, but is nevertheless, a beautiful structure in the same sense that the modern automobile, in comparison with the early "horseless carriage," is a beautiful object. Combining excellence of proportion with complete adaptation to conditions, it is a perfect expression of fitness. The Marietta and Winona bridges (Figs. 34 and 35) are, compared with the Pont de Frans and the Red Rock cantilever, at the

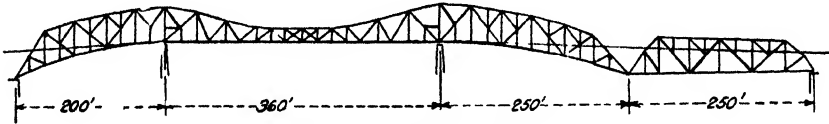

FIG. 35.—Winona Bridge.

other extreme of the scale. Lacking symmetry and graceful outlines and proportions—in fact, disregarding almost every requirement of beauty—they are almost fascinating for ugliness.

If any criticism may be made of the Forth Bridge, Scotland, it is that the suspended spans are not in proportion to the massive cantilevers.

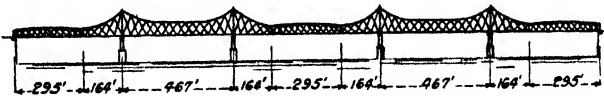

FIG. 36.—Bridge over Danube River, Cernavoda, Rumania.

The Quebec Bridge, although consisting of straight lines instead of curves, is in the main structure excellently proportioned and impressive, but the comparatively insignificant deck approach spans detract from its effectiveness as a whole. The good effect of the Beaver Bridge is partly offset by an unsymmetrical arrangement of approach spans.

¹ See *Genie Civil*, Oct. 31, 1903; "Annals de Pont et Chaussees," 1 Trimestre, 1903.

16. San Francisco-Oakland Bay Bridge, East Bay Crossing.—Of the many excellent examples of steel cantilever bridges which have been constructed since 1923, that of the East Bay Crossing of the San Francisco-Oakland Bay Bridge is outstanding in many respects. It is not only a major part of the largest bridge in the world, but it is the longest and heaviest in the United States. Only two other cantilever bridges in the world have longer spans, the Firth of Forth Bridge, Scotland, with a span of 1,700 ft., and the Quebec Bridge, Canada, with a span of 1,800 ft. The East Bay cantilever has a main span of 1,400 ft., side spans of 508 ft. each, and a vertical clearance above mean high water of 185 ft. (Fig. 37).

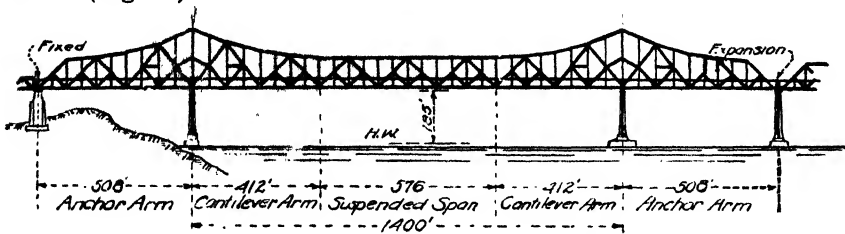

Fig. 37.—Cantilever span, San Francisco-Oakland Bay Bridge. (Courtesy of the American Bridge Co.)

This bridge is also noteworthy because of the large amounts of high-strength steels used in its construction. Of the total 22,500 tons of steel required, there were 3,600 tons of nickel steel, 9,600 tons of silicon steel, and 3,000 tons of high tensile strength eyebars. These eyebars are arranged in two tiers, one over the other, so that all members made up of such bars have a depth comparable to that of the built-up members. This arrangement adds considerably to the appearance of the bridge.

The superstructure at the west end is anchored in a fixed position to a concrete pier, which also provides a seat for a flanking span. The other three supports consist of steel towers or bents about 150 ft. high, resting on masonry piers. No expansion joints are provided in the floor except at the extreme easterly end. Expansion of the main trusses is permitted by flexure of the steel towers or bents. Because of this arrangement the main diagonal web members extend in a continuous fashion from one end of the structure to the other, without interruption by vertical hangers at the ends of the suspended span.

SECTION 6

SUSPENSION BRIDGES¹

COPYRIGHT, 1923, 1943, BY D. B. STEINMAN

STRESSES IN SUSPENSION BRIDGES

1. The Cable.

1a. Form of the Cable for Any Loading.—A cable suspended between two points will assume the outline corresponding to the equilibrium polygon of the applied loads (Fig. 1a).

The end reactions (T_1 and T_2) will be inclined and will have horizontal components H . If all the loads are vertical, H will be the same for both end reactions, and will also equal the horizontal component of the tension at any point. H is called the horizontal tension of the cable.

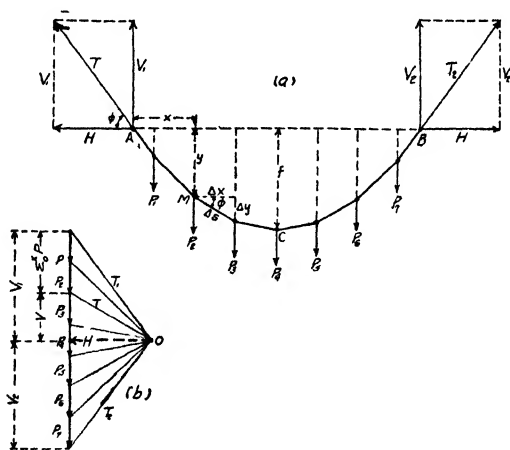

FIG. 1.—The cable as a funicular polygon.

If M' is the bending moment produced at any point of the span by the vertical loads and reactions, calculated as for a simple beam, the ordinate of the cable curve at that point (measured from the closing chord) will be

$$y = \frac{M'}{H} \quad (1)$$

¹ See also Steinman's "Suspension Bridges, Their Design, Construction, and Erection," John Wiley & Sons, New York, 1922.

Since H is constant, the curve is simply the bending moment diagram for the applied loads, drawn to the proper scale. If f is the sag of the cable, or ordinate to the lowest point C , and if M_c is the simple-beam bending moment at the same point, then H is determined by

$$H = \frac{M_c}{f} \quad (2)$$

To obtain the cable curve graphically, simply draw the equilibrium polygon for the applied loads, as indicated in Fig. 1a, b. The pole distance H must be found by trial or computation so as to make the polygon pass through the three specified points, A , B and C . The tension T at any point of the cable is given by the length of the corresponding ray of the pole diagram. H , the horizontal component of all cable tensions, is constant. If φ is the inclination of the cable to the horizontal at any point,

$$T = H \sec \varphi \quad (3)$$

It should be noted that the tensions T in the successive members of the polygon increase toward the points of support and attain their maximum values in the first and last members of the system.

If V is the vertical shear at any section of the cable, the slope at that point will be

$$\tan \varphi = \frac{V}{H} \quad (4)$$

1b. The Parabolic Cable.—If a cable carries a uniform distributed load (w per horizontal linear unit), the resulting equilibrium curve is a parabola. The horizontal tension is

$$H = \frac{wl^2}{8f} \quad (5)$$

With the origin of coordinates at the crown, the equation of the curve is

$$y = 4f \frac{x^2}{l^2} \quad (6)$$

If the origin is taken at one of the supports (as A , Fig. 1), the equation becomes

$$y = \frac{4fx}{l^2}(l - x) \quad (7)$$

The maximum tension in the cable, occurring at either support, will be

$$T_1 = \sqrt{H^2 + (\frac{1}{2}wl)^2} \quad (8)$$

or

$$T_1 = \frac{wl^2}{8f} \sqrt{1 + 16n^2} \quad (9)$$

where n denotes the ratio of the sag f to the span l .

$$n = \frac{f}{l} \quad (10)$$

The inclination of the parabolic cable at the support is given by

$$\tan \varphi_1 = \frac{4f}{l} = 4n \tag{11}$$

The exact length of the parabola between two ends at equal elevation is given by

$$L = \frac{l}{2}(1 + 16n^2)^{\frac{1}{2}} + \frac{l}{8n} \log_e \left[4n + (1 + 16n^2)^{\frac{1}{2}} \right] \tag{12}$$

When a good table of hyperbolic functions is available, a more expeditious solution is given by the equation

$$L = \frac{l}{16n}(2u + \sinh 2u) \tag{13}$$

where u is defined by $\sinh u = 4n$.

An approximate formula for the length of curve is

$$L = l(1 + \frac{8}{3}n^2 - \frac{32}{5}n^4) \tag{14}$$

where n is defined by Eq. (10). For small values of the sag-ratio n , it will be sufficiently accurate to write

$$L = l(1 + \frac{8}{3}n^2) \quad \checkmark \tag{15}$$

for the length of a parabolic cable in terms of its chord l .

The following table gives the values of L as computed by the exact and approximate formulas, respectively.

Sag-ratio $n = \frac{f}{l}$	Length ratio = $\frac{L}{l}$	
	Exact (Eq. (12) or (13))	Approx. (Eq. (14))
0.05	1.00662	1.00663
0.075	1.01475	1.01480
0.1	1.02603	1.02603
0.125	1.04019	1.04010
0.15	1.05693	1.05676
0.175	1.07647	1.07566
0.2	1.09822	1.09643

1c. Unsymmetrical Spans.—If the two ends of a cable span are not at the same elevation, the ordinates y should be measured vertically from the inclined closing chord AB (Fig. 2). If that is done, all of the principles derived above will remain applicable, and Eqs. (1) to (7), inclusive, may be kept unchanged.

For a load uniform along the horizontal, the curve will be a parabola, and its equation, referred to the origin A and to the axis AB , will be as before

$$y = \frac{4fx}{l^2}(l - x) \tag{7}$$

If it is desired to refer the curve to the horizontal line AD , with which the closing chord makes an angle α , the equation becomes

$$y' = \frac{4fx}{l^2}(l - x) + x \tan \alpha \tag{16}$$

The lowest point of the curve, V , is located by the abscissa

$$x_v = \frac{l}{2} \left(1 + \frac{l}{4f} \tan \alpha \right) \tag{17}$$

To find the exact length of the curve, apply Eq. (12) or (13) to the segments VA and VB (Fig. 2), treating each of these segments as one-half of a complete parabola, and add the results.

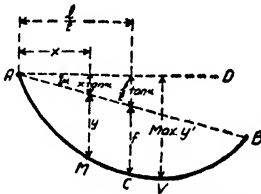

FIG. 2.—Unsymmetrical parabolic cable.

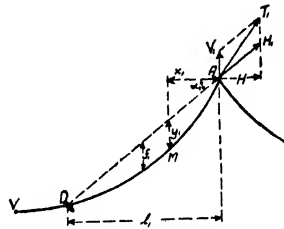

FIG. 3.—Parabolic cable in side span.

An extreme case of the unsymmetrical parabolic curve occurs in the side-span cables of suspension bridges. Using the notation shown in Fig. 3, the equation of the curve may be written, similar to Eq. (7),

$$y_1 = \frac{4f_1x_1}{l_1^2}(l_1 - x_1) \tag{18}$$

Here, again, y_1 and f_1 are measured vertically from the closing chord, and x_1 and l_1 are measured horizontally.

The true vertex of the curve or lowest point V will generally be found, by an equation similar to Eq. (17), to be outside point D (Fig. 3). The exact length of curve will be VA minus VD , or the difference between two semi-parabolas each of which may be calculated by Eq. (12) or (13).

An approximate value of the cable length in a side span is given by

$$L_1 = l_1 \left(\sec \alpha_1 + \frac{8}{3} \frac{n_1^2}{\sec^3 \alpha_1} \right) \checkmark \tag{19}$$

where

$$n_1 = \frac{f_1}{l_1} \tag{20}$$

Similar to Eq. (1), the side span cable ordinates are given by

$$y_1 = \frac{M'}{H} \tag{21}$$

and, similar to Eq. (5), we have

$$H = \frac{w_1 l_1^3}{8f_1} \tag{22}$$

In order that the main and side spans shall have equal values of H , the necessary relation between the sags is

$$\frac{f_1}{f} = \frac{w_1 l_1^2}{w l^2} \quad (23)$$

The stress at any point of the cable is given by Eq. (3) or by

$$T = H(1 + \tan^2 \varphi)^{1/2} \quad (24)$$

At the center of the side span, where $x_1 = \frac{l_1}{2}$, and the inclination is equal to α_1 ,

$$T = H(1 + \tan^2 \alpha_1)^{1/2} \quad (25)$$

At the support, where $x_1 = 0$, the inclination of the cable is given by

$$\tan \varphi_1 = \tan \alpha_1 + \frac{4f_1}{l_1} \quad (26)$$

and the maximum stress in the cable is

$$T_1 = H \sec \varphi_1 \quad (27)$$

1d. The Catenary.—If the load w is not constant per horizontal unit, but per unit length of the curve, as is the case when the load on the cable is due to its own weight, the cable curve is a catenary with the equation

$$y = \frac{1}{2c} (e^{cx} + e^{-cx} - 2) \quad (28)$$

where

$$c = \frac{w}{H}$$

Using hyperbolic functions, Eq. (28) may be written

$$y = \frac{1}{c} (\cosh cx - 1) \quad (29)$$

The total length of the catenary (between two ends at equal elevation) is given by

$$L = \frac{1}{c} (e^{c\frac{l}{2}} - e^{-c\frac{l}{2}}) \quad (30)$$

or, expressed in hyperbolic functions,

$$L = \frac{2}{c} \sinh \frac{cl}{2} \quad (31)$$

Equations (29) and (31) are useful in computations for the guide wires employed for the regulation of the strands in cable erection. If the length L is known, Eq. (31) may be solved for the parameter c , using a method of successive approximations, and the ordinates then obtained from Eq. (29). Good tables of hyperbolic functions will expedite the solution.

The length from the vertex to any point of the catenary is also given by

$$L = \frac{1}{c} \sqrt{2cy + c^2 y^2} \quad (32)$$

which may be used for unsymmetrical catenaries.

The stress at any point will be

$$T = \frac{w}{2c} (e^{cx} + e^{-cx}) \quad (33)$$

or, in hyperbolic functions,

$$T = H \cosh cx. \quad (34)$$

The last equation may also be written in the convenient form

$$T = wy + H \quad (35)$$

At the span center, where $y = 0$, this gives $T = H$; and at the supports where $y = f$, we have

$$T_1 = wf + H \quad (36)$$

If the sag-ratio ($n = \frac{f}{l}$) is small, all of the formulas for the catenary may be replaced, with sufficient accuracy, by the formulas for parabolic cables.

1e. Deformations of the Cable.—As a result of elastic elongation, slipping in the saddles, or temperature changes, the length of cable between supports may alter by an amount ΔL ; as a result of tower deflection or saddle displacement, the span may alter by an amount Δl . The resulting center deflections, or changes in cable-sag, are then given by

$$\Delta f = + \frac{15}{16n(5 - 24n^2)} \Delta L \quad (37)$$

and

$$\Delta f = - \frac{15 - 40n^2 + 288n^4}{16n(5 - 24n^2)} \Delta l \quad (38)$$

For a change in temperature of t degrees, coefficient of expansion ω , the change in cable length will be

$$\Delta L = \omega t L \quad (39)$$

For any loading which produces a horizontal tension H , the elastic elongation will be, very closely,

$$\Delta L = \frac{L}{l} \cdot \frac{HL}{EA} \quad (40)$$

where E is the coefficient of elasticity and A is the area of cross-section of the cable. Another expression for the elastic elongation is

$$\Delta L = \frac{HL}{EA} \left(1 + \frac{16}{3} n^2 \right) \quad (41)$$

2. Unstiffened Suspension Bridges.

Unstiffened Suspension Bridges.—The unstiffened suspension bridge is not used for important structures. The usual form, as indicated in Fig. 4, consists of a cable passing over two towers and anchored by backstays to a firm foundation. The roadway is suspended from the cable by means of hangers or suspenders. As there is no stiffening truss, the cable is free to assume the equilibrium curve of the applied loading.

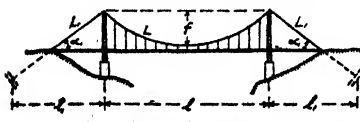

FIG. 4.—Unstiffened suspension bridge.

2a. Stresses in the Cables and Towers.—If built-up chains are used, as in the early suspension bridges, the cross-section may be varied in proportion to the stresses under maximum loading. In a wire cable, the cross-section is uniform throughout.

As the cable and hangers are light in comparison with the roadway, the combined weight of the three may be considered as uniformly distributed along the horizontal. Let this total dead load be w lb. per lin. ft. The cable will then assume a parabolic curve; and all of the relations represented by Eqs. (5) to (15) will apply.

For a uniform live load of p lb. per lin. ft., the maximum cable stress will occur when the load covers the whole span, and will have a value

$$T_p = \frac{pl^2}{8f} (1 + 16n^2)^{\frac{1}{2}} \tag{42}$$

Adding the dead load stress, we obtain the total stress in the cable at the towers:

$$T_{(w+p)} = \frac{(w+p)l^2}{8f} (1 + 16n^2)^{\frac{1}{2}} \tag{43}$$

If α_1 is the inclination of the backstay to the horizontal (Fig. 4), the stress in the backstay will be

$$T_1 = H \sec \alpha_1 \tag{44}$$

If cable and backstay have equal inclinations at the tower, their stresses, represented by Eqs. (43) and (44), will be equal.

The vertical reaction of the main cable at the tower is $(w+p) \frac{l}{2}$. If the backstay has the same inclination as the cable, it will also have the same vertical reaction, so that the total stress in the tower will be

$$T = (w+p)l \tag{45}$$

2b. Deformations under Central Loading.—Under partial loading, the unstiffened cable will be distorted from its initial parabolic curve. It is required to find the deflections produced by the change of curve, disregarding for the present any stretching of the cable or any displacement of the saddles.

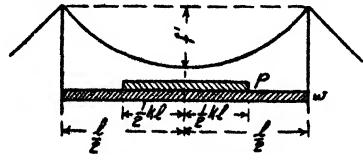

Fig. 5.—Loading for maximum vertical deflection.

The maximum vertical deflection at the center of the cable will occur when a certain central portion of length kl is covered with live load p , in addition to the dead load w covering the whole span (Fig. 5).

For different values of the load ratio $\frac{p}{w}$, we obtain the following values for the maximum crown deflection Δf :

For $\frac{p}{w} = 0$	$\frac{1}{4}$	$\frac{1}{3}$	$\frac{1}{2}$	1	2	3
$k = 1.0$	0.64	0.30	0.28	0.25	0.23	0.21
$\Delta f = 0$	0.013	0.022	0.028	0.045	0.067	0.080 <i>f</i>

From this table we obtain the following empirical values, sufficiently accurate between the limits $q = \frac{p}{w} = \frac{1}{4}$ to 4:

$$\left. \begin{aligned} k &= 0.20 + \frac{0.05}{q} \\ \Delta f &= (0.007 + 0.046q - 0.0075q^2)f \end{aligned} \right\} \quad (46)$$

2c. Deformations under Unsymmetrical Loading.—The greatest distortion of the cable from symmetry, represented by the

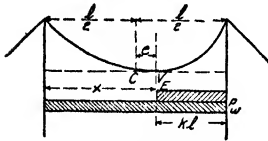

FIG. 6.—Maximum horizontal displacement of the crown.

maximum horizontal displacement of the low point or vertex, *V*, will be produced by a continuous uniform load extending for some distance *kl* from the end of the span (Fig. 6). The maximum deviation *e* of the crown *V* from the center of the span *C* will then occur when the head of the moving load reaches the low point *V*, and is given by

$$\frac{e}{l} = \frac{1}{2} + \frac{w}{p} - \sqrt{\frac{w}{p} + \frac{w^2}{p^2}} \quad (47)$$

The uplift of the cable at the center of the span will then amount to

$$\Delta f = \left(\frac{2e}{l + 2e} \right)^2 f \quad (48)$$

We thus obtain the following values:

For $\frac{p}{w} = \frac{1}{4}$	$\frac{1}{3}$	$\frac{1}{2}$	1	$\frac{3}{2}$	2	3	4
$e = 0.028$	0.036	0.051	0.086	0.105	0.134	0.167	0.191 <i>l</i>
$\Delta f = 0.003$	0.004	0.008	0.021	0.030	0.045	0.062	0.076 <i>f</i>

2d. Deflections Due to Elongation of Cable.—The total length of cable including the backstays is

$$L + 2L_1 = l \left(1 + \frac{3}{8} n^2 - \frac{3}{8} n^4 \right) + 2l_1 \sec \alpha_1 \quad (49)$$

For a change in temperature of t degrees, the total elongation of cable will be

$$\Delta L = \omega t(L + 2L_1) \quad (50)$$

For the elongation of the cable due to elastic strain, we may write

$$\Delta L = \frac{H}{EA} \left[l \left(1 + \frac{16}{3} n^2 \right) + 2l_1 \sec^2 \alpha_1 \right] \quad (51)$$

In addition there may be a contribution to ΔL from yielding of the anchorages.

If the cable is capable of slipping over the fixed saddles, the resulting deflection Δf is obtained by substituting the above values of ΔL in Eq. (37).

If, however, a displacement of the saddles will occur before the cable will slip, any elongation of the backstays will alter the span l but not the length L of the cable in the main span. In that case, the combined effects of temperature and elastic strain will give:

$$\Delta L = \omega tL + \frac{Hl}{EA} \left(1 + \frac{16}{3} n^2 \right) \quad (52)$$

and

$$\Delta l = -2 \sec \alpha_1 \left(\omega t l_1 \sec \alpha_1 + \frac{Hl_1}{EA_1} \sec^2 \alpha_1 \right) \quad (53)$$

The resulting deflection Δf of the main cable will be:

$$\Delta f = \frac{15}{16(5n - 24n^3)} \Delta L - \frac{15 - 40n^2 + 288n^4}{16(5n - 24n^3)} \Delta l \quad (54)$$

3. Stiffened Suspension Bridges.—In order to restrict the static distortions of the flexible cable discussed in the preceding pages, there is introduced a stiffening truss connected to the cable by hangers (Figs. 7, 13). The side spans may likewise be suspended from the cable (Figs. 10, 14), or they may be independently supported; in the latter case the backstays will be straight (Figs. 13, 16). The main span truss may be simply supported at the towers (Figs. 10, 13), or it may be built continuous with the side spans (Figs. 14, 16). A hinge may be introduced at the center of the stiffening truss in order to make the structure statically determinate (Fig. 8), or to reduce the degree of indeterminateness.

Another form of stiffened suspension bridge is the "braced-chain" or "suspension truss" type. Instead of using a straight stiffening truss suspended from a cable, the suspension system itself is made rigid enough to resist distortion by building it in the form of an inverted arch (Figs. 17, 18, 19, 20).

For ease of designation, it will be convenient to adopt the following symbolic classification of stiffened suspension bridges based on the number of hinges in the main span of the truss:

Stiffened suspension bridges	}	Stiffening truss	<i>Continuous</i>	Side span free = 0F (Fig. 16)	
				Side span suspended = 0S (Fig. 14)	
			<i>One-hinged</i>	Side span free = 1F	
				Side span suspended = 1S	
			<i>Two-hinged</i>	Side span free = 2F (Fig. 13)	
				Side span suspended = 2S (Fig. 10)	
		Braced chain	}	<i>Three-hinged</i>	Side span free = 3F (Fig. 8)
					Side span suspended = 3S
				<i>Hingeless</i> = 0B (Fig. 20)	
				<i>One-hinged</i> = 1B	
		<i>Two-hinged</i> = 2B (Fig. 19)			
		<i>Three-hinged</i> = 3B (Figs. 17, 18)			

In Types 2F and 3F, the side spans are not related to the main elements of the structure and may therefore be omitted from consideration. Hence these types are called "single-span bridges."

The suspension bridges with straight stiffening trusses will be presented first.

3a. Assumptions Used.—In the theory that follows, we adopt the assumption that the truss is sufficiently stiff to render the deformations of the cable due to moving load practically negligible; in other words, we assume, as in all other rigid structures, that the lever arms of the applied forces are not altered by the deformations of the system. The resulting theory is the one ordinarily employed, and is sufficiently accurate for all practical purposes; any errors are generally small and on the side of safety.

If the stiffening truss is not very stiff, or if the span is long, the deflections of truss and cable may be too large to neglect. To provide for such cases, there has been developed an exact method of calculation which takes into account the deformations of the system. For lack of space, this "Exact Theory" will not be presented here, but the interested reader is referred instead to other works on the subject.¹

¹ MELAN-STEINMAN, "Theory of Arches and Suspension Bridges," pp. 76 to 86, McGraw-Hill Book Co., 1913.

JOHNSON, BRYAN AND TURNEAURE, "Modern Framed Structures," Part II, pp. 276 to 318, John Wiley & Sons, 1911.

BURR, "Suspension Bridges," pp. 212 to 247, John Wiley & Sons, 1913.

The common theory developed in the following pages for the analysis of suspension bridges with stiffening trusses is based on five assumptions, which are very near the actual conditions:

- (1) The cable is supposed perfectly flexible, freely assuming the form of the equilibrium polygon of the suspender forces.
- (2) The truss is considered a beam, initially straight and horizontal, of constant moment of inertia and tied to the cable throughout its length.
- (3) The dead load of truss and cable is assumed uniform per lineal unit, so that the initial curve of the cable is a parabola.
- (4) The form and ordinates of the cable curve are assumed to remain unaltered upon application of loading.
- (5) The dead load is carried wholly by the cable and causes no stress in the stiffening truss. The truss is stressed only by live load and by changes of temperature.

The last assumption is based on erection adjustments, involving regulation of the hangers and riveting-up of the trusses when assumed conditions of dead load and temperature are realized.

3b. Fundamental Relations.—Since the cable in the stiffened suspension bridge is assumed to be parabolic, the loads acting on it must always be uniform per horizontal unit of length. All of the relations established for a uniformly loaded cable (Eqs. (5) to (27)) will apply in this case.

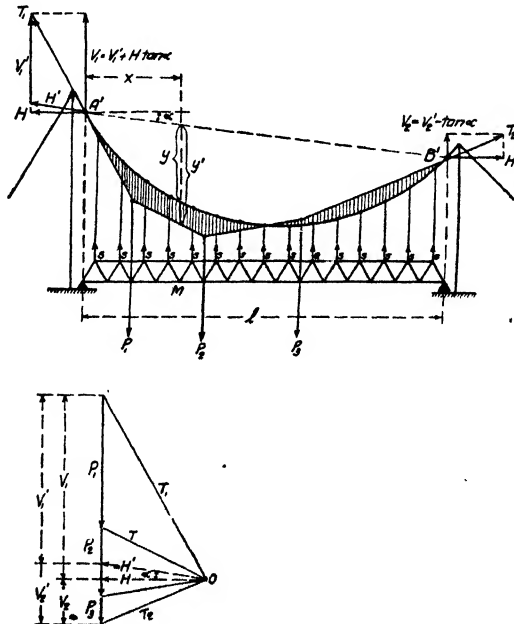

FIG. 7.—Forces acting on the stiffening truss.

If the panel points are uniformly spaced (horizontally), the suspender forces must be uniform throughout (Fig. 7). These suspender forces are loads acting downward on the cable, and upward on the stiffening

truss. It is the function of the stiffening truss to take any live load that may be arbitrarily placed upon it and distribute it uniformly to the hangers.

The cable maintains equilibrium between the horizontal tension H (resisted by the anchorages) and the downward acting suspender forces. If these suspender forces per horizontal linear unit are denoted by s , they are given by

$$s = H \cdot \frac{8f}{l^2} \quad (55)$$

The truss (Fig. 7) must remain in equilibrium under the arbitrarily applied loads acting downward and the uniformly distributed suspender forces acting upward. If we imagine the last forces removed, then the bending moment M' and shear V' at any section of the truss may be determined exactly as for an ordinary beam (simple or continuous as the truss rests on two or more supports).

If the stiffening truss is a simple beam (hinged at the towers), the bending moment at any section due to the suspender forces is

$$M_s = Hy \quad (56)$$

and the total moment at the section will be

$$M = M' - Hy \quad (57)$$

where y is the ordinate to the cable curve measured from the straight line joining A' and B' , the points of the cable directly above the ends of the truss (Fig. 7).

If φ is the inclination of the cable at the section considered, the shear produced by the hanger forces is given by

$$V_s = H(\tan \varphi - \tan \alpha) \quad (58)$$

and the total shear will be

$$V = V' - H(\tan \varphi - \tan \alpha) \quad (59)$$

where α is the inclination of the closing line $A'B'$ below the horizontal (generally zero).

In Eqs. (57) and (59), the last term represents the relief of bending moment or shear by the cable tension H .

Representing M' by the ordinates y' of an equilibrium polygon or curve constructed for the applied loading with a pole distance = H , Eq. (57) takes the form

$$M = H(y' - y) \quad (60)$$

Hence the bending moment at any section of the stiffening truss is represented by the vertical intercept between the axis of the cable and the equilibrium polygon for the applied loads drawn through the points $A'B'$ (Fig. 7).

If the stiffening truss is continuous over several spans, the relations represented by Eqs. (56) to (60), inclusive, must be modified to take into account the continuity at the towers. The corresponding formulas will be developed in the section on continuous stiffening trusses.

3c. Influence Lines.—To facilitate the study and determination of suspension bridge stresses for various loadings, influence diagrams are most convenient.

The base for all influence diagrams is the H -curve or H -influence line. This is obtained by plotting the equations giving the values of H for varying positions of a unit concentration. In the case of three-hinged suspension bridges, the H -influence line is a triangle (Figs. 8 and 9). In the case of two-hinged stiffening trusses, the H -lines (Figs. 10, 12) are similar to the deflection curves of simple beams under uniformly distributed load. In the case of continuous stiffening trusses, the H -line (Fig. 14) is similar to the deflection curve of a three-span continuous beam covered with uniform load in the suspended spans.

To obtain the influence diagrams for bending moments and shears, all that is necessary is to superimpose on the H -curve, as a base, appropriately scaled influence lines for moments and shears in straight beams.

For this purpose, the general expression for bending moments at any section (Eq. (57)) is written in the form

$$M = y \left(\frac{M'}{y} - H \right) \quad (61)$$

(excepting that in the case of continuous stiffening trusses, y is to be replaced by $y - ef$; see Eq. (158)). For a moving concentration, $\frac{M'}{y}$ represents the moment influence line of a straight beam, simple or continuous as the case may be, constructed with the pole distance y . If this influence line is superimposed upon the H -influence line (Figs. 8b, 10b, 10c, 14b), the intercepts between them, multiplied by y , will give the desired bending moments M . In the case of stiffening trusses with hinges at the towers, M' is the same as the simple-beam bending moment, and its influence line is simply a triangle whose altitude at the given section is

$$\frac{M'}{y} = \frac{l}{4f} \quad (62)$$

The $\frac{M'}{y}$ triangles for all sections will have the same altitudes (Figs. 8b, 10b). The corresponding altitude for sections in the side spans is $\frac{l_1}{4f_1}$ (Fig. 10c). The area intercepted between the H -line and the $\frac{M'}{y}$ triangles, multiplied by py , give the maximum and minimum bending moments at the given section x of the stiffening truss. Areas below the

H -line represent positive moments, and those above represent negative moments (Figs. 8, 10, 14). Where the two superimposed lines intersect, we have a point K , which may be called the zero point, since a concentration placed at K produces zero bending stress at x . K is also called the critical point, since it determines the limit of loading for maximum positive or negative moment at x . Load to one side of K yields plus bending, and load to the other side produces negative bending.

The expression for shear at any section of the stiffening truss, (Eq. (59)), is written in the form:

$$V = \left[\frac{V'}{\tan \varphi - \tan \alpha} - H \right] (\tan \varphi - \tan \alpha) \quad (63)$$

where α , the inclination of the closing chord, is generally zero. For any given section x , the slope of the cable is constant and is given by

$$\tan \varphi - \tan \alpha = \frac{4f}{l} \left(1 - \frac{2x}{l} \right) \quad (64)$$

The values assumed by the bracketed expression in Eq. (63) for different positions of a concentrated load may be represented as the difference between the ordinates of the H -line and those of the influence line for V' , the latter being reduced in the ratio $\frac{1}{\tan \varphi - \tan \alpha}$. The latter influence line is obtained by drawing two parallel lines as and bt (Figs. 9a, 9b, 12a), their direction being fixed by the end intercepts

$$am = bn = \frac{1}{\tan \varphi - \tan \alpha} \quad (65)$$

The vertices s and t lie on the vertical passing through the given section x . The maximum shears produced by a uniformly distributed load are determined by the areas included between the H and V' influence lines; all areas below the H -line are to be considered positive, and all above negative. These areas must be multiplied by $p(\tan \varphi - \tan \alpha)$ to obtain the greatest shear V at the section; and V must be multiplied by the secant of inclination to get the greatest stress in the web members cut by the section.

Three-hinged Stiffening Trusses.

4a. Analysis.—This is the only type of stiffened suspension bridge that is statically determinate. The condition of zero bending moment at the central hinge enables H to be directly determined. The value of H for any loading is equal to the simple-beam bending moment (M_0') at the center hinge divided by the sag f :

$$H = \frac{M_0'}{f} \quad (66)$$

The cable will receive its maximum stress when the full span is covered with the live load p . In that case

$$H = \frac{pl^2}{8f} \quad (67)$$

and

$$s = p \quad (68)$$

Hence, under full live load, the conditions are similar to those for dead load, the cable carrying all the load and the trusses having no stress. At any section, $M = 0$ and $V = 0$.

For a single load P at a distance kl from the near end of the span, the value H will be

$$H = \frac{Pkl}{2f} \quad (69)$$

This value of H will be a maximum for $k = \frac{1}{2}$, yielding

$$\text{Max. } H = \frac{Pl}{4f} \quad (70)$$

The influence line for H is a triangle defined by Eq. (69), and its altitude (at the center of the span) is given by Eq. (70) as $\frac{l}{4f}$. Figures 8b and 9a show the H -line constructed in this manner.

If the truss is uniformly loaded for a distance kl from one end, the value of H will be:

$$\text{for } k < \frac{1}{2}, H = \frac{pl^2}{4f}(k^2) \quad (71)$$

$$\text{for } k > \frac{1}{2}, H = \frac{pl^2}{8f}(4k - 2k^2 - 1) \quad (72)$$

For the half-span loaded, we find

$$H = \frac{pl^2}{16f} \quad (73)$$

and

$$s = \frac{1}{2}p \quad (74)$$

One-half of the span is thus subjected to an unbalanced upward load, $s = \frac{1}{2}p$, per lineal foot, and the other half sustains an equal downward load, $p - s = \frac{1}{2}p$. The maximum moments for this loading, occurring at the quarter points ($x = \frac{1}{4}l$, $x = \frac{3}{4}l$), will be

$$\text{Max. } M = \pm \frac{1}{64}pl^2 = \pm 0.01562pl^2 \quad (75)$$

4b. Moments in the Stiffening Truss.—The influence diagram for bending moments at any section x is constructed by superimposing the $\frac{M'}{y}$ triangle upon the H -influence triangle, as shown in Fig. 8b.

The two influence triangles intersect a short distance to the left of the center, giving the zero point or critical point *K*.

Since the two superimposed triangles have the same base and equal altitudes, the plus and minus intercepted areas will be equal. Hence, if the whole span is loaded, the resultant bending moment at any section *x* will be zero.

If either of the shaded areas is multiplied by *py*, it will give the maximum value of the bending moment at *x*.

The distance *kl* to the critical point *K* (Fig. 8*b*) is defined by

$$k = \frac{l}{3l - 2x} \tag{76}$$

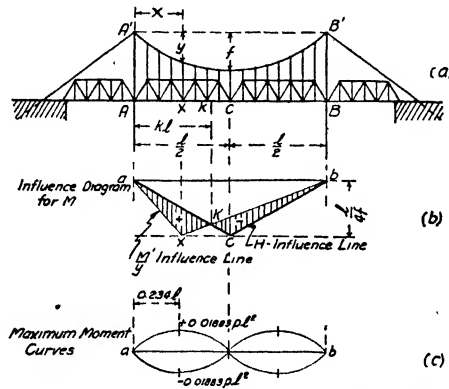

FIG. 8.—Three-hinged stiffening truss (Type 3*F*)—Moment diagrams.

With this distance loaded, we obtain the maximum value of *M* for any value of *x*.

$$\text{Max. } M = \frac{px(l - x)(l - 2x)}{2(3l - 2x)} \tag{77}$$

The absolute maximum *M* occurs at $x = 0.234l$ when $k = 0.395$, and amounts to

$$\text{Abs. Max. } M = +0.01883pl^2 \tag{78}$$

or about $\frac{1}{53}pl^2$.

After the maximum moments at the different sections along the span are evaluated from the influence lines or from Eq. (77), they may be plotted in the form of curves as shown in Fig. 8*c*. For the three-hinged stiffening truss, these maximum moment curves are symmetrical about the horizontal axis. They serve as a guide for proportioning the chord sections of the stiffening truss.

4c. Shears in the Stiffening Truss.—The shears produced in the stiffening truss by any loading are given by Eq. (59); but the maximum values at the different sections are most conveniently determined with the aid of influence lines (Fig. 9).

The influence line for H is a triangle with altitude $= \frac{l}{4f}$ at the center of the span. Upon this is superimposed the influence line for shears in a simple beam, reduced in the ratio $1: \tan \phi$. The resulting influence diagram for shear V at a given section $x < \frac{l}{4}$ is shown in Fig. 9a. There are two zero points or critical points at x and at kl . The latter point K is given by

$$k = \frac{1}{3 - 4 \frac{x}{l}} \tag{79}$$

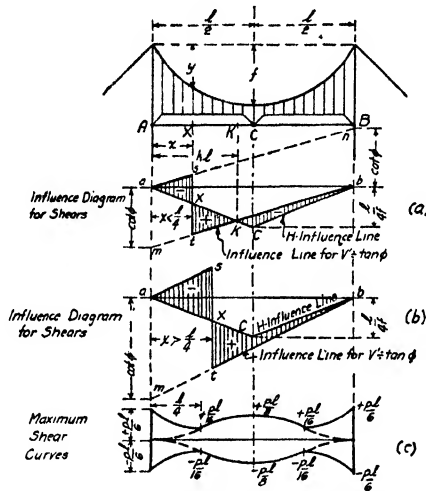

FIG. 9.—Shear diagrams for three-hinged stiffening truss (Type 3F).

With the load covering the length from x to kl , we obtain the maximum positive shear at x :

$$\text{Max. } V = \frac{pl}{2} \frac{\left(1 - 3 \frac{x}{l} + 4 \frac{x^2}{l^2}\right)^2}{3 - 4 \frac{x}{l}} \tag{80}$$

When $x = 0$, or for end-shear, $k = \frac{1}{3}$, and we obtain:

$$\text{Abs. Max. } V = \frac{pl}{6} \tag{81}$$

When $x = \frac{1}{4}$, we find $k = \frac{1}{2}$, and

$$\text{Max. } V = \frac{pl}{16} \tag{82}$$

For $x > \frac{1}{4}$, the influence diagram takes the form shown in Fig. 9b. There is only one zero point, namely at the section x . Loading all of the span beyond x , we obtain the maximum positive shear:

$$\text{Max. } V = \frac{px^2}{2l} \left(3 - 4 \frac{x}{l}\right) \tag{83}$$

This has its greatest value for $x = \frac{1}{2}l$, or at the center, where it becomes

$$\text{Max. } V = \frac{pl}{8} \tag{84}$$

The maximum negative shears throughout the span have values identical with Eqs. (80) to (84), but with opposite signs.

Figure 9c gives curves showing the variation of maximum positive and negative shears from end to end of the span. The curves are a guide for proportioning the web members of the stiffening truss.

If the two ends of the cable are at unequal elevations, the foregoing results for shear (Eqs. (79) to (84), inclusive) must be modified on account of the necessary substitution throughout of $(\tan \varphi - \tan \alpha)$ for $\tan \varphi$ as required by Eq. (59).

5. Two-hinged Stiffening Trusses.

5a. Determination of the Horizontal Tension H .—In these bridge systems, the horizontal tension H is statically indeterminate. The equation for the determination of H is therefore deduced from the elastic deformations of the system.

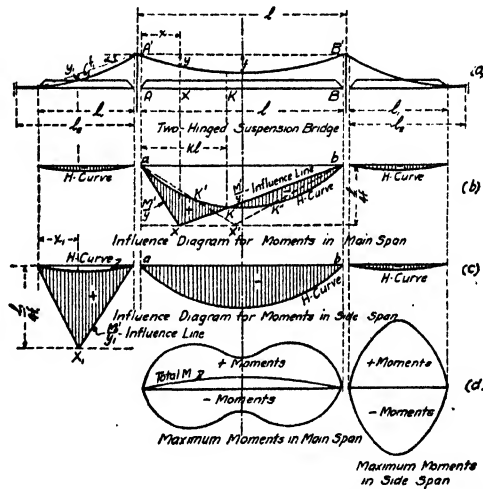

FIG. 10.—Moment diagrams for two-hinged stiffening truss (Type 2S).

The expression for H consists of a fraction whose numerator depends upon the loading and whose denominator (N) depends upon the constants of the structure. This denominator, for a two-hinged stiffening truss, is given by

$$N = \frac{8}{5}(1 + 2irv^2) + \frac{3I}{Af^2} \cdot \frac{E}{E_0} \cdot \frac{l}{l} (1 + 8n^2 + \frac{3}{2} \tan^2 \alpha) + \frac{6I}{Af^2} \cdot \frac{E}{E_0} \cdot \frac{l_2}{l} \sec^2 \alpha_1 (1 + 8n_1^2) \tag{85}$$

where (see Fig. 10a):

l = length of main span of stiffening truss.

l_1 = length of side span of stiffening truss.

f = vertical sag of cable in main span (l).

f_1 = vertical sag of cable in side span (l_1).

$$n = \frac{f}{l}, n_1 = \frac{f_1}{l_1}$$

I = average moment of inertia of truss in main span.

I_1 = average moment of inertia of truss in side span.

$$i = \frac{I}{I_1}, r = \frac{l_1}{l}, v = \frac{f_1}{f}$$

A = cable section in main span.

A_1 = cable section in side span (generally equal to A).

E = coefficient of elasticity of material of truss.

E_c = coefficient of elasticity of material of cable.

l' = span of cable, center to center of towers
(which may be somewhat greater than l).

l_2 = horizontal distance from tower to anchorage
(which may be somewhat greater than l_1).

α = inclination of cable chord in main span.

α_1 = inclination of cable chord in side span.

In the expression for N , (Eq. (85)), the first term is derived from the bending of the stiffening truss, and the other two terms from the stretching of the cable in main and side spans, respectively. The truss term contributes about 95 per cent, and the cable terms only about 5 per cent of the total. Hence certain approximations are permissible in evaluating the cable terms. Terms for the towers and hangers have been omitted as their contribution to the value of N would be only a small decimal of 1 per cent.

For a concentration P at a distance kl from either end of the main span, the value of the horizontal tension will be

$$H = \frac{1}{Nn} \cdot B(k) \cdot P \quad (86)$$

where N is given by Eq. (85), and the function

$$B(k) = k(1 - 2k^2 + k^3) \quad (87)$$

and may be obtained directly from Table 1 or from the graph in Fig. 11. The above value of H is a maximum when the load P is at the middle of the span; then $k = \frac{1}{2}$, and Eq. (86) yields

$$\text{Max. } H = \frac{5}{16} \cdot \frac{1}{Nn} \cdot P \quad (88)$$

Similarly, for a concentration P in either side span, at a distance $k_1 l_1$ from either end,

$$H = \frac{1}{Nn} \cdot ir^2v \cdot B(k_1) \cdot P \quad (89)$$

where $B(k_1)$ is the same function as defined by Eq. (87). This value of H is a maximum when the load P is at the middle of the side span; then $k_1 = \frac{1}{2}$, and Eq. (89) yields

$$\text{Max. } H = \frac{5}{16} \cdot \frac{1}{Nn} \cdot ir^2v \cdot P \quad (90)$$

TABLE 1.—FUNCTIONS OCCURRING IN SUSPENSION BRIDGE FORMULAS

k	H -influence line	Critical points	Minimum moments	H for uniform loads	Shears	k
	$B(k)$	$C(k)$	$D(k)$	$F(k)$	$G(k)$	
	$k(1-2k^2+k^3)$	$k+k^2-k^3$	$(2-k-4k^2+3k^3)(1-k)^2$	$\frac{5}{2}k^2-\frac{5}{2}k^3+k^5$	$\frac{3}{2}(1-k)^3-(1-k)^2+1$	
0	0	0	2.0000	0	0.4000	0
0.05	0.0498	0.0524	1.7511	0.0062	0.4404	0.05
0.10	0.0981	0.1090	1.5090	0.0248	0.4816	0.10
0.15	0.1438	0.1691	1.2790	0.0550	0.5232	0.15
0.20	0.1856	0.2320	1.0650	0.0963	0.5648	0.20
0.25	0.2227	0.2969	0.8704	0.1474	0.6062	0.25
0.30	0.2541	0.3630	0.6962	0.2072	0.6472	0.30
0.35	0.2793	0.4296	0.5445	0.2740	0.6874	0.35
0.40	0.2976	0.4960	0.4147	0.3462	0.7264	0.40
0.45	0.3088	0.5614	0.3065	0.4222	0.7640	0.45
0.50	0.3125	0.6250	0.2188	0.5000	0.8000	0.50
0.55	0.3088	0.6861	0.1497	0.5778	0.8340	0.55
0.60	0.2976	0.7440	0.0973	0.6538	0.8656	0.60
0.65	0.2793	0.7979	0.0593	0.7260	0.8946	0.65
0.70	0.2541	0.8470	0.0332	0.7928	0.9208	0.70
0.75	0.2227	0.8906	0.0166	0.8526	0.9438	0.75
0.80	0.1856	0.9280	0.0070	0.9037	0.9632	0.80
0.85	0.1438	0.9584	0.0023	0.9450	0.9788	0.85
0.90	0.0981	0.9810	0.0005	0.9752	0.9904	0.90
0.95	0.0498	0.9951	0.0003	0.9938	0.9976	0.95
1.00	0	1.0000	0	1.0000	1.0000	1.00

By plotting Eqs. (86) and (89) for different values of k and k_1 , we obtain the H -curves or influence lines for H (Figs. 10, 12). The maximum ordinates of these curves are given by Eqs. (88) and (90).

For a uniform load of p lb. per ft., extending a distance kl from either end of the main span, we find

$$H = \frac{1}{5Nn} \cdot F(k) \cdot pl \quad (91)$$

where the function

$$Fk = \frac{5}{2}(k)^2 - \frac{5}{2}k^3 + k^5 \quad (92)$$

and may be obtained directly from Table 1 or from the graph in Fig. 11. For $k = 1$, $F(k) = 1$.

For similar conditions in either side span, we find, for a loaded length k_1l ,

$$H = \frac{1}{5Nn} \cdot ir^2v \cdot F(k_1) \cdot p_1l \quad (93)$$

where $F(k_1)$ is the same function as defined by Eq. (92).

The horizontal component of the cable tension will be a maximum when all spans are fully loaded ($k = 1$ and $k_1 = 1$), giving

$$\text{Total } H = \frac{1}{5Nn}(1 + 2ir^2v)pl \tag{94}$$

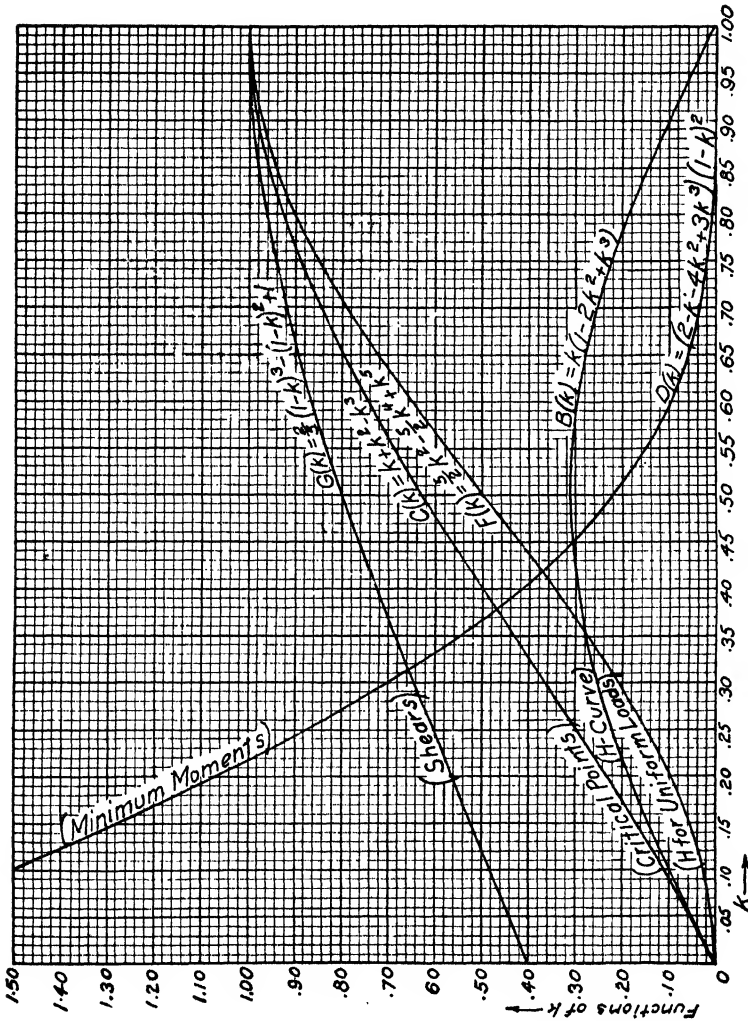

Fig. 11.—Graphs for the solution of suspension bridge formulas.

For a live load covering a portion JK of the main span, from $x = jl$ to $x = kl$,

$$H = \frac{1}{5Nn} [F(k) - F(j)]pl \tag{95}$$

The graph of $F(k)$ in Fig. 11 shows the proportional increase in the value of H as a uniform load comes on and fills the main span (or either side span).

5b. Moments in the Stiffening Truss.—With all three spans loaded, the bending moment at any section of the main span will be

$$\text{Total } M = \frac{1}{2} px(l-x) \left[1 - \frac{8}{5N} (1 + 2ir^3v) \right] \quad (96)$$

and, at any section of the side spans,

$$\text{Total } M_1 = \frac{1}{2} px_1(l_1 - x_1) \left[1 - \frac{8}{5N} (1 + 2ir^3v) \frac{v}{r^2} \right] \quad (97)$$

The influence diagrams for bending moment are constructed, in accordance with Eq. (61), by superimposing the influence triangle for $\frac{M'}{y}$ on the H -influence curve: The H -curve is plotted with ordinates given by Eqs. (86) and (89); the $\frac{M'}{y}$ triangles have a constant height, $\frac{l}{4f}$ in the main span and $\frac{l_1}{4f_1}$ in the side spans. The resulting influence diagrams are shown in Figs. 10b and 10c. The intercepted areas, multiplied by py , give the desired bending moments; areas below the H -curve represent positive or maximum moments, and those above represent negative or minimum moments.

For any section in the main span there is a zero point or critical point K (Fig. 10b), represented by the intersection of the superimposed influence lines. The distance kl to this critical point is given by the relation

$$C(k) = k + k^2 - k^3 = Nn \frac{x}{y} \quad (98)$$

Values of the function $C(k)$ are listed in Table 1 and plotted in a graph in Fig. 11, to facilitate the solution of Eq. (98) for k .

The maximum negative moment at any section of the main span is obtained by loading the length $l - kl$ in that span and completely loading both side spans; this yields

$$\text{Min. } M = - \frac{2px(l-x)}{5N} [D(k) + 4ir^3v] \quad (99)$$

where the function

$$D(k) = (2 - k - 4k^2 + 3k^3)(1 - k)^2 \quad (100)$$

and is given, for different values of k , by Table 1 and by the graph in Fig. 11. The value of k obtained from Eq. (98) is to be used.

For the sections near the center of the span, from $x' = \frac{N}{4} \cdot l$ to $l - x'$, there are two critical points (see dotted diagram, Fig. 10b); it is necessary to bring on some load also from the left end of the span; consequently for these sections there must be added in Eq. (99) to $D(k)$ corresponding to the given section x the value of $D(k)$ corresponding to the symmetrically located section $(l - x)$.

The maximum positive moments are given by the relation

$$\text{Max. } M = \text{Total } M - \text{Min. } M \quad (101)$$

The loading corresponding to this moment is indicated in Fig. 10b; only a portion of the main span is loaded, the side spans being without load.

There are no critical points in the side spans. For the greatest negative moment at any section x_1 in one of the side spans, load the other two spans (Fig. 10c), giving

$$\text{Min. } M_1 = -y_1 \cdot \frac{1 + ir^3v}{5Nn} \cdot pl \tag{102}$$

Loading the span itself produces the greatest positive moments, which are obtained by the relation

$$\text{Max. } M_1 = \text{Total } M_1 - \text{Min. } M_1 \tag{103}$$

The maximum and minimum moments for the various sections of a stiffening truss (Type 2S), as calculated from Eqs. (99), (101), (102), (103), are plotted in Fig. 10d, to serve as a guide in proportioning the chord members.

5c. Shears in the Stiffening Truss.—With the three spans completely loaded, the shear at any section x in the main span will be,

$$\text{Total } V = \frac{1}{2} p(l - 2x) \left[1 - \frac{8}{5N} (1 + 2ir^3v) \right] \tag{104}$$

and, in the side spans,

$$\text{Total } V_1 = \frac{1}{2} p(l_1 - 2x_1) \left[1 - \frac{8}{5N} \cdot \frac{v}{r^2} \cdot (1 + 2ir^3v) \right] \tag{105}$$

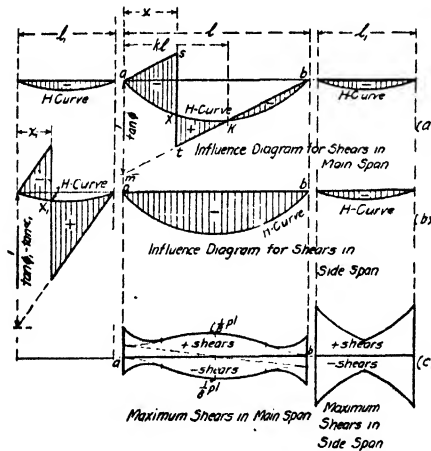

FIG. 12.—Shear diagrams for two-hinged stiffening truss (Type 2S).

The influence diagram for shear at any section is constructed according to Eq. (63) by superimposing on the H -curve (Eqs. (86) and (89))

the influence lines for $\frac{V'}{\tan \varphi}$. The latter will have end intercepts = $\cot \varphi$ where φ is the slope of the cable at the given section. The resulting influence diagram is shown in Fig. 12a. The intercepted areas multiplied

by $p \tan \varphi$, give the desired vertical shears V . Areas below the H -curve represent positive or maximum shears, and areas above represent negative or minimum shears.

Loading the main span from the given section x to the end of the span, we obtain the maximum positive shears by the formula:

$$\text{Max. } V = \frac{1}{2} pl \left(1 - \frac{x}{l}\right)^2 \left[1 - \frac{8}{N} \left(\frac{1}{2} - \frac{x}{l}\right) \cdot G\left(\frac{x}{l}\right)\right] \quad (106)$$

where the function

$$G\left(\frac{x}{l}\right) = \frac{2}{5} \left(1 - \frac{x}{l}\right)^3 - \left(1 - \frac{x}{l}\right)^2 + 1 \quad (107)$$

and is given by Table 1 and the graph in Fig. 11.

For the sections near the ends of the span, from $x = 0$ to $x = \frac{l}{2} \left(1 - \frac{N}{4}\right)$, the loads

must not extend to the end of the span to produce the maximum positive shears, but must extend only to a point K (Fig. 12a) whose abscissa $x = kl$ is determined by the following equation:

$$C(k) = k + k^2 - k^3 = \frac{N}{4} \cdot \frac{l}{l - 2x} \quad (108)$$

For these sections, the positive shears given by Eq. (106) must be increased by an amount:

$$\text{Add. } V = \frac{1}{2} pl(1 - k)^2 \cdot \left[\frac{8}{N} \left(\frac{1}{2} - \frac{x}{l}\right) \cdot G(k) - 1\right] \quad (109)$$

where the function

$$G(k) = \frac{2}{5} (1 - k)^3 - (1 - k)^2 + 1 \quad (110)$$

and, like the same function in Eq. (107) is given by Table 1 and the graph in Fig. 11.

Equation (108) for the critical section is also solved with the aid of Table 1 or the graph in Fig. 11.

There are no critical points for shear in the side spans. The influence diagram Fig. 12b shows the conditions of loading. For maximum shear at any section x_1 , the load extends from the section to the tower, giving

$$\text{Max. } V_1 = \frac{1}{2} pl_1 \left(1 - \frac{x_1}{l_1}\right)^2 \left[1 - \frac{8}{N} \left(\frac{1}{2} - \frac{x_1}{l_1}\right) \cdot G\left(\frac{x_1}{l_1}\right)\right] \quad (111)$$

where $G\left(\frac{x_1}{l_1}\right)$ is the same function as defined by Eqs. (107) and (110).

The maximum negative shears in main and side spans are given by the relations

$$\text{Min. } V = \text{Total } V - \text{Max. } V \quad (112)$$

and

$$\text{Min. } V_1 = \text{Total } V_1 - \text{Max. } V_1 \quad (113)$$

The maximum positive and negative shears for different sections of the main and side spans, as given by Eqs. (106), (109), (111), (112) and (113), are plotted for a typical suspension bridge, in Fig. 12c, to serve as a guide in proportioning the web members.

5d. Temperature Stresses.—The total length of cable between anchorages is, by Eqs. (15) and (19),

$$L = l \left(1 + \frac{8}{3} n^2 \right) + 2l_1 \left(\sec \alpha_1 + \frac{8}{3} \frac{n_1^2}{\sec^3 \alpha_1} \right) \quad (114)$$

Corrections should be added to this value of L for any portions of the cable not included in the spans l or l_1 .

Under the influence of a rise in temperature, the total increase in length between anchorages will be

$$\Delta = \omega t L \quad (115)$$

and the resulting cable tension will be

$$H_t = - \frac{3EI \cdot \omega t L}{f^2 N l} \quad (116)$$

where N is given by Eq. (85) and L by Eq. (114). (For an extreme variation of $t = \pm 60^\circ \text{ F.}$, $E\omega t = 11,720$.)

The resulting bending moment at any section of the truss is given by

$$M_t = -H_t y \quad (117)$$

and the vertical shear by

$$V_t = -H_t (\tan \varphi - \tan \alpha) \quad (118)$$

where φ is the inclination of the cable at the given section, and α is the inclination of the cable chord (see Eq. (64)).

5e. Deflections of the Stiffening Truss.—For any specified loading, the deflections of the stiffening truss may be computed as the difference between the downward deflections produced by the applied loads and the upward deflections produced by the suspender forces, the stiffening truss being treated as a simple beam (for Types 2F and 2S). The suspender forces are equivalent to an upward acting load, uniformly distributed over the entire span, and amounting to

$$s = \frac{8f}{l^2} \cdot H \quad (119)$$

For a uniform load p covering the main span, the resultant effective load acting on the stiffening truss will be

$$p - s = p \left(1 - \frac{8}{5N} \right) \quad (119)$$

and the resulting deflection at mid-span will be

$$d = \frac{5}{384} \left(1 - \frac{8}{5N} \right) \frac{pl^4}{EI} \quad (120)$$

For any loading, the upward deflection at any section x due to the suspender forces will be

$$d'' = \frac{fl^3}{3EI} \cdot B \left(\frac{x}{l} \right) \cdot H \quad (121)$$

where the function $B\left(\frac{x}{l}\right)$ is defined by Eq. (87). If d' is the downward deflection at the same section due to the applied loads, the resultant deflection will be

$$d = d' - d'' \quad (122)$$

If merely the half-span is loaded with p per unit length, the deflection at the quarter point will be, in the loaded half,

$$d = \frac{1}{6,144} \left(31 - \frac{57}{2} \cdot \frac{8}{5N} \right) \frac{pl^4}{EI} \quad (123)$$

and, in the unloaded half,

$$d = -\frac{1}{6,144} \left(\frac{57}{2} \cdot \frac{8}{5N} - 26 \right) \frac{pl^4}{EI} \quad (124)$$

Whatever the value of the structural constant N , the relative deflection of the two-quarter points will be, for this loading,

$$d = \frac{5}{384} \cdot \frac{p}{EI} \left(\frac{l}{2} \right)^4 \quad (125)$$

The deflections produced by temperature effects or by a yielding of the anchorages are given by

$$d'' = B\left(\frac{x}{l}\right) \cdot \frac{\Delta L}{Nn} \quad (126)$$

where the function $B\left(\frac{x}{l}\right)$ is defined by Eq. (87) and is given by Table 1 and the graph in Fig. 11.

5f. Straight Backstays (Type 2F).—If the stiffening truss is built independent of the cables in the side spans (Fig. 13), the backstays

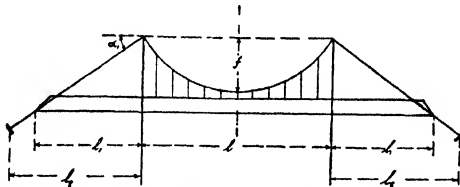

FIG. 13.—Two-hinged stiffening truss with straight backstays (Type 2F).

will be straight and $f_1 = 0$. Consequently all terms containing f_1 , y_1 , $n_1 = \frac{f_1}{l_1}$, or $v = \frac{f_1}{f}$ will vanish in Eqs. (85) to (126), inclusive.

The side spans will then act as simple beams, unaffected by any loads in the other spans; and the main span and cable stresses will be unaffected by any loads in the side spans.

The denominator of the expression for H (Eq. 85) will then reduce to

$$N = \frac{8}{5} + \frac{3I}{Af^2} \cdot \frac{E}{E_c} \cdot \frac{l^3}{l} \cdot (1 + 8n^2) + \frac{6I}{A_1f^2} \cdot \frac{E}{E_c} \cdot \frac{l_2}{l} \cdot \sec^2 \alpha_1 \quad (127)$$

Equations (89), (93), and (102) will vanish.

The maximum value of H will be produced by a uniform load p covering the main span, and will be, by Eq. (94),

$$\text{Total } H = \frac{pl}{5Nn} \quad (128)$$

The bending moment at any section x of the main span will then be, by Eq. (96),

$$\text{Total } M = \frac{1}{2} px(l-x) \left(1 - \frac{8}{5N}\right) \quad (129)$$

The greatest negative bending moment will be, by Eq. (99),

$$\text{Min. } M = -\frac{2px(l-x)}{5N} \cdot D(k) \quad (130)$$

The greatest positive moment is then given by

$$\text{Max. } M = \text{Total } M - \text{Min. } M \quad (101)$$

In the side spans, there will be no negative moments. The greatest positive moments will be

$$\text{Max. } M_1 = \text{Total } M_1 = \frac{1}{2} p_1 x_1 (l_1 - x_1) \quad (131)$$

With load covering the entire span, the shears in the main span will be, by Eq. (104),

$$\text{Total } V = \frac{1}{2} p(l-2x) \left(1 - \frac{8}{5N}\right) \quad (132)$$

and, in the side spans, by Eq. (105),

$$\text{Total } V_1 = \frac{1}{2} p_1 (l_1 - 2x_1) \quad (133)$$

The maximum shears in the main span will be given by Eqs. (106), (108) and (109). In the side span, the maximum shears will be, by Eq. (111),

$$\text{Max. } V_1 = \frac{1}{2} p_1 l_1 \left(1 - \frac{x_1}{l_1}\right)^2 \quad (134)$$

exactly as in a simple beam.

The total length of cable will be, by Eq. (114),

$$L = l' \left(1 + \frac{8}{3} n^2\right) + 2l_2 \cdot \sec \alpha_1 \quad (135)$$

and the temperature stresses are then given by Eqs. (116), (117) and (118).

6. Hingeless Stiffening Trusses (*Types 0F and 0S*).

6a. Fundamental Relations.—Hingeless stiffening trusses are continuous at the towers; hence there will be bending moments in the truss at the towers (Fig. 14a).

For any loading, the resultant bending moments in the main span will be given by (Fig. 15):

$$M = M_0 + \frac{l-x}{l} M_1 + \frac{x}{l} M_2 - H(y-ef) \quad (136)$$

and, in the side spans, by:

$$M = M_0 + \frac{x_1}{l_1} M_{1,2} - H\left(y_1 - \frac{x_1}{l_1} \cdot ef\right) \quad (137)$$

where:

M_0 = the simple-beam bending moment at the section x , due to the downward loads.

M_1, M_2 = the bending moments at the towers, due to the downward loads.

e = a constant of continuity defined by

$$e = \frac{2 + 2irv}{3 + 2ir} \tag{138}$$

The ratio-constants i, r , and v are defined under Eq. (85). The abscissa x_1 is measured from the free end of the span and y_1 is the vertical ordinate of the side cable below the connecting chord $D'A'$ (Fig. 14a).

If any span is without load, M_0 for that span will vanish.

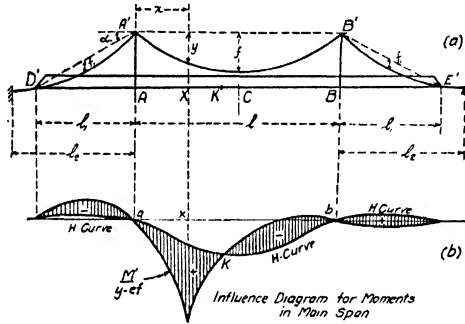

FIG. 14.—Moment diagram for continuous stiffening truss (Type OS).

The term containing H in Eq. (136) or (137) represents the moments M_s produced by the upward-acting suspender forces. The other terms give the moment M' due to the downward-acting loads ($M = M' - M_s$).

For any loading, the resultant shears in the main span will be given by:

$$V = V_0 + \frac{M_2 - M_1}{l} - H(\tan \varphi - \tan \alpha) \tag{139}$$

and, in the side spans, by:

$$V = V_0 \pm \frac{M_{1,2}}{l_1} - H\left(\tan \varphi_1 - \tan \alpha_1 - \frac{ef}{l_1}\right) \tag{140}$$

where:

V_0 = the simple beam shear at the section, due to the downward loads and the other symbols are as defined above.

If any span is without load, V_0 for that span will vanish. If the two towers are of equal height, then, in the main span, $\alpha = 0$.

6b. Moments at the Tower (Types OF and OS).—The values of the end moments M_1 and M_2 , used in Eqs. (136) to (140), may be determined for any given loading, by the Theorem of Three Moments.

For a concentration P in the main span, at a distance kl from the left tower, we thus obtain,

$$M_1 = -Pl \cdot k(1-k) \frac{(3+2ir)(1-k) + 2ir}{(3+2ir)(1+2ir)} \quad (141)$$

$$M_2 = -Pl \cdot k(1-k) \frac{(3+2ir)k + 2ir}{(3+2ir)(1+2ir)} \quad (142)$$

For a concentration P in the left side span, at a distance kl_1 from the outer end,

$$M_1 = -Pl \frac{2ir^2(1+ir)(k-k^3)}{(3+2ir)(1+2ir)} \quad (143)$$

$$M_2 = +Pl \frac{ir^2(k-k^3)}{(3+2ir)(1+2ir)} \quad (144)$$

For a uniform load covering the main span, we obtain

$$M_1 = M_2 = -\frac{pl^2}{4(3+2ir)} \quad (145)$$

For a uniform load covering the left-side span, we obtain

$$M_1 = -\frac{p_1 l^2}{4} \cdot \frac{2ir^3(1+ir)}{(3+2ir)(1+2ir)} \quad (146)$$

$$M_2 = +\frac{p_1 l^2}{4} \cdot \frac{ir^3}{(3+2ir)(1+2ir)} \quad (147)$$

For a uniform load covering all three spans, we obtain

$$M_1 = M_2 = -\frac{pl^2}{4} \cdot \frac{1+ir^3}{3+2ir} \quad (148)$$

6c. The Horizontal Tension H .—For the continuous type of suspension bridge, the denominator of the expression for H will be (in place of Eq. (85)):

$$N = \frac{8}{5} - 4e + 3e^2 + 2ir \left(\frac{8}{5}v^2 + e^2 - 2ev \right) + \frac{E}{E_c} \cdot \frac{3I}{Af^2} \cdot \frac{l'}{l} (1 + 8n^2) \\ + \frac{E}{E_c} \cdot \frac{6I}{A_1 f^2} \cdot \frac{l_2}{l} \cdot \sec^2 \alpha_1 (1 + 8n_1^2) \quad (149)$$

(If hinges are inserted at the towers, the coefficient of continuity e , defined by Eq. (138), will be zero, and Eq. (149) will reduce to Eq. (85).)

For a single load P at a distance kl from either end of the main span, the horizontal tension will be

$$H = \frac{1}{Nn} \left[B(k) - \frac{3}{2}e(k-k^2) \right] P \quad (150)$$

where N is defined by Eq. (149); and the function $B(k)$ is defined by Eq. (87) and is given by Table 1 and Fig. 11.

Similarly, for a concentration P_1 in either side span, at a distance $k_1 l_1$ from the free end, we obtain

$$H = \frac{ir^2}{Nn} \left[vB(k_1) - \frac{e}{2}(k_1 - k_1^3) \right] P_1 \quad (151)$$

Plotting Eqs. (150) and (151), we obtain the H -influence line, Fig. 14b.

If the main span is completely loaded, we obtain:

$$H = \frac{1}{Nn} \left(\frac{1}{5} - \frac{e}{4} \right) pl \quad (152)$$

If both side spans are completely loaded, we obtain:

$$H = \frac{2ir^3}{Nn} \left(\frac{v}{5} - \frac{e}{8} \right) p_1 l \quad (153)$$

If the main span is loaded for a distance kl from either tower, we obtain:

$$H = \frac{1}{5Nn} \left[F(k) - \frac{5e}{4} (3 - 2k)k^2 \right] pl \quad (154)$$

where $F(k)$ is defined by Eq. (92) and is given by Table 1 and Fig. 11.

If either side span is loaded for a distance $k_1 l_1$ from the free end, we obtain:

$$H = \frac{1}{5Nn} \cdot ir^3 \left[vF(k_1) - \frac{5}{8} e (2 - k_1)^2 k_1^2 \right] p_1 l \quad (155)$$

where $F(k_1)$ is the same function as defined by Eq. (92).

In the foregoing equations, N is given by Eq. (149).

If the stiffening truss is interrupted at the towers, the factor of continuity $e = 0$, and the above formulas reduce to the corresponding Eqs. (85) to (95) for the two-hinged stiffening truss.

6d. Moments in the Stiffening Truss.—With all three spans loaded, the bending moment at any section of the main span is given very closely, by Eqs. (136) and (148), as

$$\text{Total } M = \left(\frac{1}{2} p - H \frac{4f}{l^2} \right) x(l - x) - e \left(\frac{1}{8} pl^2 - Hf \right) \quad (156)$$

and, at any section of the side span distant x_1 from the free end, by Eqs. (137) and (148), as

$$\text{Total } M = \left(\frac{1}{2} p - H \frac{4f_1}{l_1^2} \right) x_1(l_1 - x_1) - e \left(\frac{1}{8} p l_1^2 - Hf \right) \frac{x_1}{l_1} \quad (157)$$

where e is defined by Eq. (138) and H is given by the combination of Eqs. (152) and (153).

The moments for other loadings must be calculated by the general Eqs. (136) and (137), with the values of H given by Eqs. (150) to (155), and the values of M_1 and M_2 given by Eqs. (141) to (148).

Influence lines for moments may be drawn as in the previous cases. For moments in the main span, Eq. (136) is written in the form

$$M = \left[\frac{M_0 + M_1 \frac{l-x}{l} + M_2 \frac{x}{l}}{y - ef} - H \right] (y - ef) \quad (158)$$

thus giving the bending moments as $(y - ef)$ times the intercepts obtained by superimposing the influence line for $\frac{M'}{y - ef}$ upon the influence line for H . This construction

is indicated in Fig. 14b. For moments in the side spans, the corresponding influence line equation is obtained from Eq. (137):

$$M = \left[\frac{M_0 + \frac{x_1}{l_1} M_{1,2}}{y_1 - \frac{x_1}{l_1} ef} - H \right] (y_1 - \frac{x_1}{l_1} ef) \tag{159}$$

For the continuous stiffening truss, the influence line method just outlined is not very convenient, as the M' influence line (Fig. 14b) is a curve for which there is no simple, direct method of plotting.

A more convenient method is that of the equilibrium polygon constructed with pole-distance H , corresponding to Eq. (60) and Fig. 7. For the continuous stiffening truss, this construction is modified as follows (Fig. 15): At a distance ef below the closing chord $A'B'$, a base line AB is drawn, so that the cable ordinates measured from this base line will be $y - ef$ and will therefore represent the suspender moments M_s . The

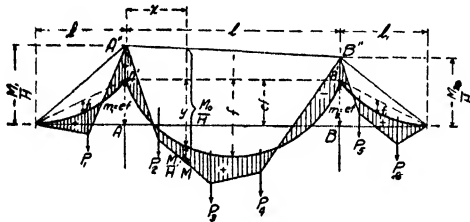

FIG. 15.—Equilibrium polygon for continuous stiffening truss (Type OS).

equilibrium polygon $A''MB''$ for any given loads is then constructed upon the same base line, with the same pole-distance H ; the height AA'' represents $-M_1$, the height BB'' represents $-M_2$, and the polygon ordinates below $A''B''$ represent M_0 ; hence, the ordinates measured below the base line AB represent the moments M' due to the downward-acting loads. Then, by Eq. (136), the intercept between the cable curve and the superimposed equilibrium polygon, multiplied by H , will give the resultant bending moment M at any section.

For a single concentrated load P , the equilibrium polygon $A''MB''$ is a triangle, and the M intercepts can easily be scaled or figured. By moving a unit load P to successive panel points, we thus obtain a set of influence values of M for all sections.

The corresponding construction in the side spans is also indicated in Fig. 15.

6e. Temperature Stresses.—The horizontal tension produced by a rise in temperature of t deg. is given by

$$H_t = -\frac{3EI\alpha tL}{f^2NI} \tag{160}$$

where N is defined by Eq. (149), and L is given by Eq. (114).

The resulting moments in the stiffening truss will be

$$M_t = -H_t(y - ef) \quad (161)$$

for the main span, and

$$M_t = -H_t\left(y_1 - \frac{x_1}{l_1}ef\right) \quad (162)$$

for the side spans.

The vertical shears are given by

$$V_t = -H_t(\tan \varphi - \tan \alpha) \quad (163)$$

for the main span, and

$$V_t = -H_t\left(\tan \varphi_1 - \tan \alpha_1 - \frac{ef}{l_1}\right) \quad (164)$$

for the side spans.

6f. Straight Backstays (Type 0F).—If the stiffening truss in the side spans is built independent of the cable (Fig. 16), the backstays will be straight and $f_1 = 0$. Consequently all terms containing f_1 , y_1 , $n_1 = \frac{f_1}{l_1}$, or $v = \frac{f_1}{f}$, will vanish in Eqs. (136) to (164), inclusive.

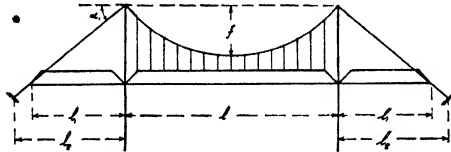

FIG. 16.—Continuous stiffening truss with straight backstays (Type 0F).

On account of the continuity of the trusses, however, each span will be affected by loads in the other spans.

The denominator of the expression for H , Eq. (149), will become

$$N = \frac{8}{5} - 2e + \frac{3I}{Af^2} \cdot \frac{E}{E_c} \cdot \frac{l'}{l} (1 + 8n^2) + \frac{6I}{A_1 f^2} \cdot \frac{E}{E_c} \cdot \frac{l_2}{l} \cdot \sec^3 \alpha_1 \quad (165)$$

where e , the factor of continuity, now has the value

$$e = \frac{2}{3 + 2ir} \quad (166)$$

Equation (137), for bending moments in the side spans, will become

$$M = M_0 + \frac{x_1}{l_1} \cdot M_{1,2} + H \cdot \frac{x_1}{l_1} \cdot ef \quad (167)$$

and Eq. (140), for shears in the side spans, will become

$$V = V_0 \pm \frac{M_{1,2}}{l_1} + H \cdot \frac{ef}{l_1} \quad (168)$$

For a concentration P_1 in either side span, Eq. (151) becomes

$$H = -\frac{1}{2Nn} \cdot ir^2 e (k_1 - k_1^3) \cdot P_1 \quad (169)$$

For a uniform load covering both side spans, Eq. (153) becomes

$$H = -\frac{ir^3e}{4Nn} \cdot p_1l \tag{170}$$

For a uniform load in either side span, covering a length k_1l_1 from the free end, Eq. (155) becomes

$$H = -\frac{ir^3e}{8Nn}(2 - k_1^2) k_1^2 \cdot p_1l \tag{171}$$

For a uniform load covering all three spans, Eq. (157) becomes

$$\text{Total } M = \frac{1}{2} px_1(l_1 - x_1) - \frac{ex_1}{l_1}(\frac{1}{8}pl^2 - Hf) \tag{172}$$

Equation (162), for temperature moments in the side spans becomes,

$$M_t = +H_t \cdot \frac{x_1}{l_1} \cdot ef \tag{173}$$

and Eq. (164), for shears, becomes

$$V_t = +H_t \cdot \frac{ef}{l_1} \tag{174}$$

7. Braced-chain Suspension Bridges.

7a. Three-hinged Type 3B.—The three-hinged type of braced-chain suspension bridge is statically determinate. The suspension system in the main span is simply an inverted three-hinged arch. The equilibrium polygon for any applied loading will always pass through the three hinges. The H -influence line for vertical loads reduces to a triangle whose altitude, if the crown-hinge is at the middle of the span and if the corresponding sag is denoted by f , is

$$H = \frac{l}{4f} \tag{175}$$

The determination of the stresses is made, either analytically or graphically, exactly as for a three-hinged arch.

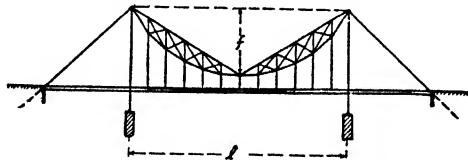

FIG. 17.—Three-hinged braced chain with straight backstays (Type 3BF).

Figure 17 shows the single-span type, in which the backstays are straight (Type 3BF). If the lower chord is made to coincide with the equilibrium polygon for dead load or full live load, the stresses in the top chord and the web members will be zero for such loading conditions. These members will then be stressed only by partial or non-uniform loading. Under partial loading, the equilibrium polygon will be displaced from coincidence with the lower chord: where it passes between the two chords, both will be in tension; where it passes below the bottom chord,

this member will be in tension and the top chord will be in compression. If the curve of the bottom chord is made such that the equilibrium polygon will fall near the center of the truss or between the two chords under all conditions of loading, the stresses in both chords will always be tension.

Figure 18 shows the three-hinged braced-chain type of suspension bridge provided with side spans (Type 3BS). The stresses in the main span trusses are not affected by the presence of the side spans, and are found as outlined above. The stresses in the side spans are found as for simple truss spans of the same length, excepting that there must be

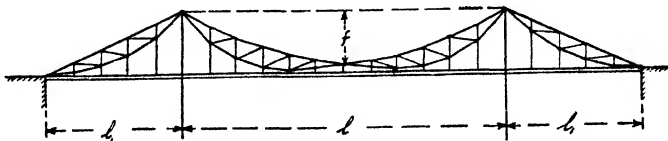

FIG. 18.—Three-hinged braced chain with side spans (Type 3BS).

added the stresses due to the top chord acting as a backstay for the main span. This top chord receives its greatest compression when the span in question is fully loaded; and its greatest tension when the main span is fully loaded.

Temperature stresses and deflection stresses in three-hinged structures are generally neglected.

7b. **Two-hinged Type 2B.**—This system (Fig. 19) is statically of single indeterminacy with reference to the external forces, so that the elastic deformations must be considered in determining the unknown reaction.



FIG. 19.—Two-hinged braced chain with side spans (Type 2BS).

The structure is virtually a series of three inverted two-hinged arch trusses, having a common horizontal tension H resisted by the anchorage.

The general equation for H takes the form:

$$H = - \frac{\sum \frac{Zul}{EA}}{\sum \frac{u^2 l}{EA}} \quad (176)$$

where Z denotes the stresses in the members for any external loading when $H = 0$ (i.e., when the system is cut at the anchorages); u denotes the stresses produced under zero loading when $H = 1$; l denotes the lengths of the respective members and A their cross-sections. The

summations embrace all the members in the entire system between anchorages.

The stress in any member is given by adding to Z the stress produced by H , or

$$S = Z + Hu \tag{177}$$

For a rise in temperature, the elastic elongations $\frac{Zl}{EA}$ are replaced by thermal elongations ωtl , and Eq. (176) becomes

$$H_t = - \frac{\sum \omega t u l}{\sum \frac{u^2 l}{EA}} \tag{178}$$

For uniform temperature rise in all the members, Eq. (178) may be written

$$H_t = - \frac{\omega t L}{\sum \frac{u^2 l}{EA}} \tag{179}$$

where L is the total horizontal length between anchorages.

A graphic method of determining H is to find the vertical deflections at all the panel points produced by a unit horizontal force ($H = 1$) applied at the ends of the system. The resulting deflection curve will be the influence line for H . If the ordinates of this curve are divided by the constant $\sum \frac{u^2 l}{EA}$ (= the horizontal displacement of the ends of the system produced by the same force, $H = 1$), they will give directly the values of H produced by a unit vertical load moving over the spans.

7c. Hingeless Type 0B.—This type of suspension bridge (Fig. 20) is three-fold statically indeterminate, the redundant unknowns



FIG. 20.—Hingeless braced cable suspension bridge (Type 0B).

being the horizontal tension H and the moments at the towers. Instead, the stresses in any three members, such as the members at the tops of the towers and one at the center of the main span, may be chosen as redundants. Let the stresses in the three redundant members, under any given loading, be denoted by X_1, X_2, X_3 . When these three members are cut, the structure is a simple three-hinged arch; in this condition, let Z denote the stresses produced by the external loads, and let u_1, u_2 , and u_3 denote the stresses produced by applying internal forces $X_1 = 1, X_2 = 1$, and $X_3 = 1$. Then, when the three redundants are restored, the stress in any member will be

$$S = Z + X_1 u_1 + X_2 u_2 + X_3 u_3 \tag{180}$$

The restoration of the redundant members must satisfy the three conditions

$$\left. \begin{aligned} \sum \frac{Zu_1l}{EA} + X_1 \sum \frac{u_1^2l}{EA} + X_2 \sum \frac{u_1u_2l}{EA} + X_3 \sum \frac{u_1u_3l}{EA} &= 0 \\ \sum \frac{Zu_2l}{EA} + X_1 \sum \frac{u_1u_2l}{EA} + X_2 \sum \frac{u_2^2l}{EA} + X_3 \sum \frac{u_2u_3l}{EA} &= 0 \\ \sum \frac{Zu_3l}{EA} + X_1 \sum \frac{u_1u_3l}{EA} + X_2 \sum \frac{u_2u_3l}{EA} + X_3 \sum \frac{u_3^2l}{EA} &= 0 \end{aligned} \right\} \quad (181)$$

The redundant members are to be included in these summations.

The solution of these three simultaneous equations will yield the three unknowns X_1 , X_2 and X_3 and their substitution in Eq. (180) will give the stresses throughout the structure.

DESIGN OF SUSPENSION BRIDGES—CONSTRUCTION FEATURES

The superior economy of the suspension type for long-span bridges is due fundamentally to the following causes:

- (1) The very direct stress-paths from the points of loading to the points of support.
- (2) The predominance of tensile stress.
- (3) The highly increased ultimate resistance of steel in the form of cable wire.

For heavy railway bridges, the suspension bridge will be more economical than any other type for spans exceeding about 1,500 ft. As the live load becomes lighter in proportion to the dead load, the suspension bridge becomes increasingly economical in comparison with other types. For light highway structures, the suspension type can be used with economic justification for spans as low as 400 ft.

Besides the economic considerations, the suspension bridge has many other points of superiority. It is light, esthetic, graceful; it provides a roadway at low elevation, and it has a low center of wind pressure; it dispenses with falsework, and is easily constructed, using materials that are easily transported; there is no danger of failure during erection; and after completion, it is the safest structure known to engineers.

The principal carrying member is the cable, and this has a vast reserve of strength. In other structures, the failure of a single truss member will precipitate a collapse; in a suspension bridge, the rest of the structure will be unaffected.

8. Types of Suspension Bridges.—There are two systems to be considered:

- (1) Suspension bridges with suspended stiffening truss (Figs. 21 to 26 inclusive).
- (2) Suspension trusses, or braced chain bridges (Fig. 27).

The main carrying member of a suspension system is generally of wire cable (Figs. 21 to 25 inclusive), sometimes of eyebar chain (Figs. 26, 27), and, in a few instances, of riveted construction (*e.g.*, Breslau).

The backstays of the cable or chain (extending from tower to anchorage) may be straight (Figs. 22, 25); or the side spans may be suspended, giving curved backstays (Figs. 21, 23, 26, 27).

The suspended stiffening truss may be made continuous over main and side spans (Fig. 26); the resulting structure is three-fold statically indeterminate. The indeterminateness may be relieved by the insertion of

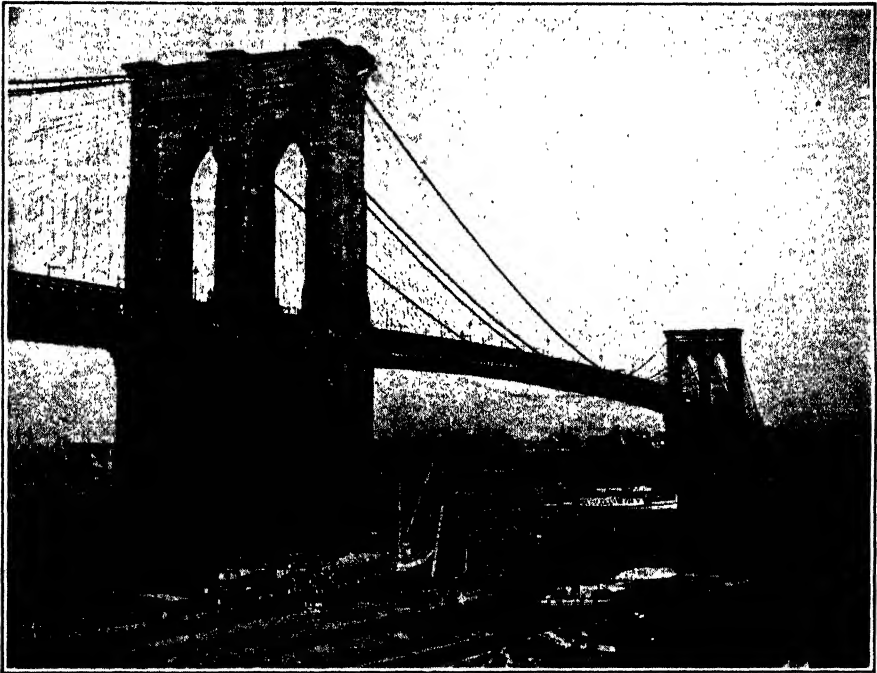

FIG. 21.—Brooklyn Bridge, East River, New York. Completed, 1883—Span 1,595½ ft.—Type 3S.

hinges or slip-joints. Usually two hinges are used, one at each tower (Figs. 22, 23, 25), producing a singly indeterminate structure. By adding a third hinge at mid-span (Figs. 21, 27), a statically determinate structure is obtained.

The suspension truss (Fig. 27) is thus far chiefly of historical or speculative interest, as modern suspension bridge construction is principally confined to the suspended stiffening truss type. An example of the suspension truss type is the Point Bridge at Pittsburgh (1877, span 800 ft.).

The use of chains instead of cables is a characteristic of European practice. Recent chain bridges are the Elizabeth Bridge at Budapest

(1903, span 951 ft.), the bridge over the Oder at Breslau (1911, span 415 ft.), and the bridge over the Rhine at Cologne (Fig. 26, 1917, span 605 ft.). With present materials and prices, chain construction generally becomes more expensive than wire cables at about 1,000-ft. span.

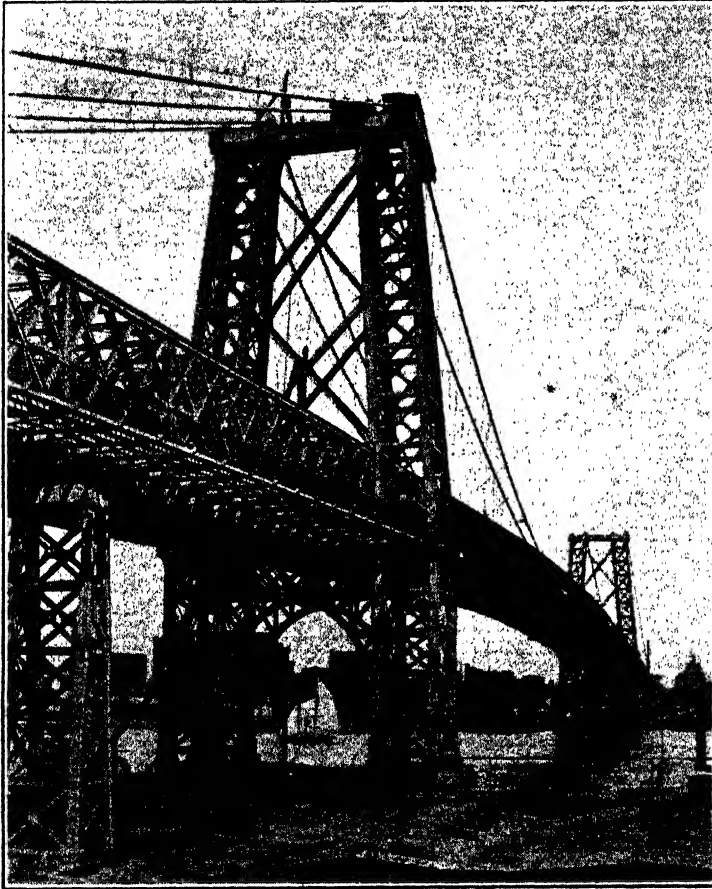

FIG. 22.—Williamsburgh Bridge, East River, New York. Completed, 1903—Span 1,600 ft.
—Type 2*F*.

9. Economic Proportions.—The economic sag-ratio for cables has been established by some authorities at 1:6, but such large sags are exceedingly uncommon. Ratios between 1:8 and 1:10 are preferable as they produce more pleasing lines and, in addition, help to increase lateral and vertical rigidity. In past practice, the ratios have, as a rule, ranged between 1:9 and 1:12. The total cost will not be materially affected.

The function of the stiffening truss is to distribute any applied load uniformly to the suspenders. If the truss is too shallow, the deformations will be excessive; if too deep, the truss will carry too great a proportion

of the load at a sacrifice of economy. The economic depth-ratio has been established by some authorities at 1:40 for 1,000-ft. spans and 1:45 for 2,000-ft. spans. The Williamsburgh Bridge (Fig. 22) has a ratio of 1:40. In the Manhattan Bridge, which has a substantial double deck floor construction contributing to the stiffness, a ratio of only 1:60 was used. The choice of depth-ratio is also affected by the character of the cross-bracing. In general, the proper ratio to use will be between 1:40 and 1:60.

For adequate lateral stiffness, the width center to center of outer stiffening trusses should not be less than about one-twenty-fourth of the span.

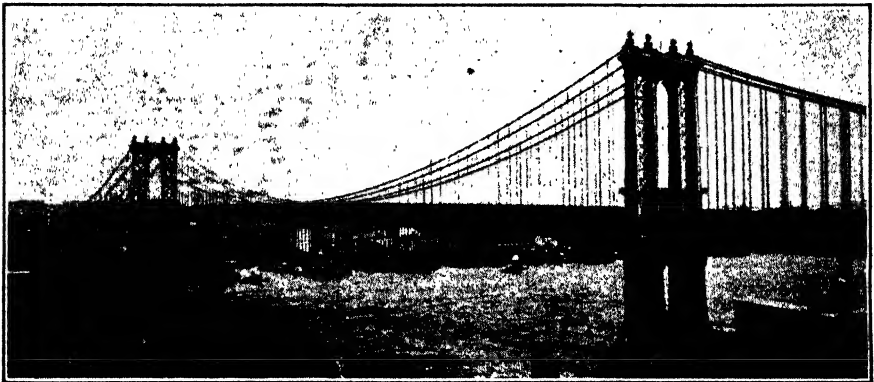

FIG. 23.—Manhattan Bridge, East River, New York. Completed, 1909—Span 1,470 ft.—Type 2S.

10. Chain Construction.—The construction of a suspension chain is similar to that of a pin-connected truss chord built of eyebars. The material is structural steel or, in recent designs, nickel steel (Figs. 26, 27). Nickel steel used in eyebar chains and in stiffening trusses has been allowed a working stress of 40,000 lb. per sq. in., the ultimate strength being 90,000 and the elastic limit 60,000 lb. per sq. in. The substitution of nickel steel for structural steel affords a saving of 10 to 15 per cent in the cost of a chain or stiffening truss. The allowable working stress is one-half to two-thirds of the elastic limit.

The eyebars are generally made by forging (upsetting and boring, Fig. 27). In Europe, eyebars are made by boring out of a full flat (Fig. 26), an extravagant procedure.

Chains made of horizontal flats superimposed and riveted together (as in the bridge at Breslau) are not to be recommended, on account of the difficulty of preventing rust between the plates. Moreover, such chains do not appear sufficiently massive in side view, and they are subject to high secondary stresses from bending.

A disadvantage of chain construction is unequal stressing of the individual bars between two pins.

11. Parallel Wire Cables.—A cable consists either of parallel wires (Figs. 21, 22, 23, 24) or of twisted wire ropes (Fig. 25).

The steel wire is reduced by repeated drawing to a diameter of 0.15 to 0.25 in. A common size is No. 6, 0.192 in. The ultimate strength is 200,000 to 225,000 lb. per sq. in., and the yield point is 140,000 to 150,000 lb. per sq. in.; the usual working stresses being 60,000 to 75,000 lb. per sq. in.

A higher yield point, up to 80 or 90 per cent of the ultimate, is obtainable by using harder wire, but such wire is too stiff for easy handling.

The proportional elastic limit of the wire is about 45 to 50 per cent. of the ultimate strength. The elongation in 20 in. is 2.5 to 4 per cent.

For protection against the weather, the wires are generally galvanized. In addition, the wires are coated with linseed oil at the mill. The finished cable is slushed with oil and wrapped with impregnated duck (Fig. 22), or preferably with wire wrapping (Figs. 21, 23).

Parallel wire cables, principally used in this country, have been made in diameters up to 21 in. (Fig. 23).

In erecting parallel wire cables, the individual wires are strung in place between the anchorages and, when the desired number is reached, bundled together in a strand; when all the strands are completed, they are compacted, clamped and finally wrapped into a cylindrical cable. The division into strands facilitates operations and makes the work systematic. The cable consists of 7, 19 or 37 strands, depending upon the size of the cable.

The following table gives data on the wire cables of the East River suspension bridges.

	Brooklyn (Fig. 21)	Williamsburgh (Fig. 22)	Manhattan (Fig. 23)
Date.....	1876-1883	1898-1903	1903-1909
Main span.....	1,595.5 ft.	1,600 ft.	1,470 ft.
Cable sag.....	128 ft.	177 ft.	160 ft.
Total load, per lin. ft.....	35,500 lb.	75,000 lb.	104,000 lb.
Number of cables.....	4	4	4
Strands per cable.....	19	37	37
Wires per strand.....	278	208	256
Wire diameter.....	0.165 in.	0.192 in.	0.195 in.
Total cross-section.....	533 sq. in.	888 sq. in.	1,092 sq. in.
Cable diameter.....	15¼ in.	18½ in.	21¼ in.
Size of wrapping wire.....	0.135 in.	0.148 in.
Maximum stress in cables.....	47,500 lb. per sq. in.	50,300 lb. per sq. in.	73,000 lb. per sq. in.
Ultimate strength of cables.....	160,000 lb. per sq. in.	200,000 lb. per sq. in.	210,000 lb. per sq. in.

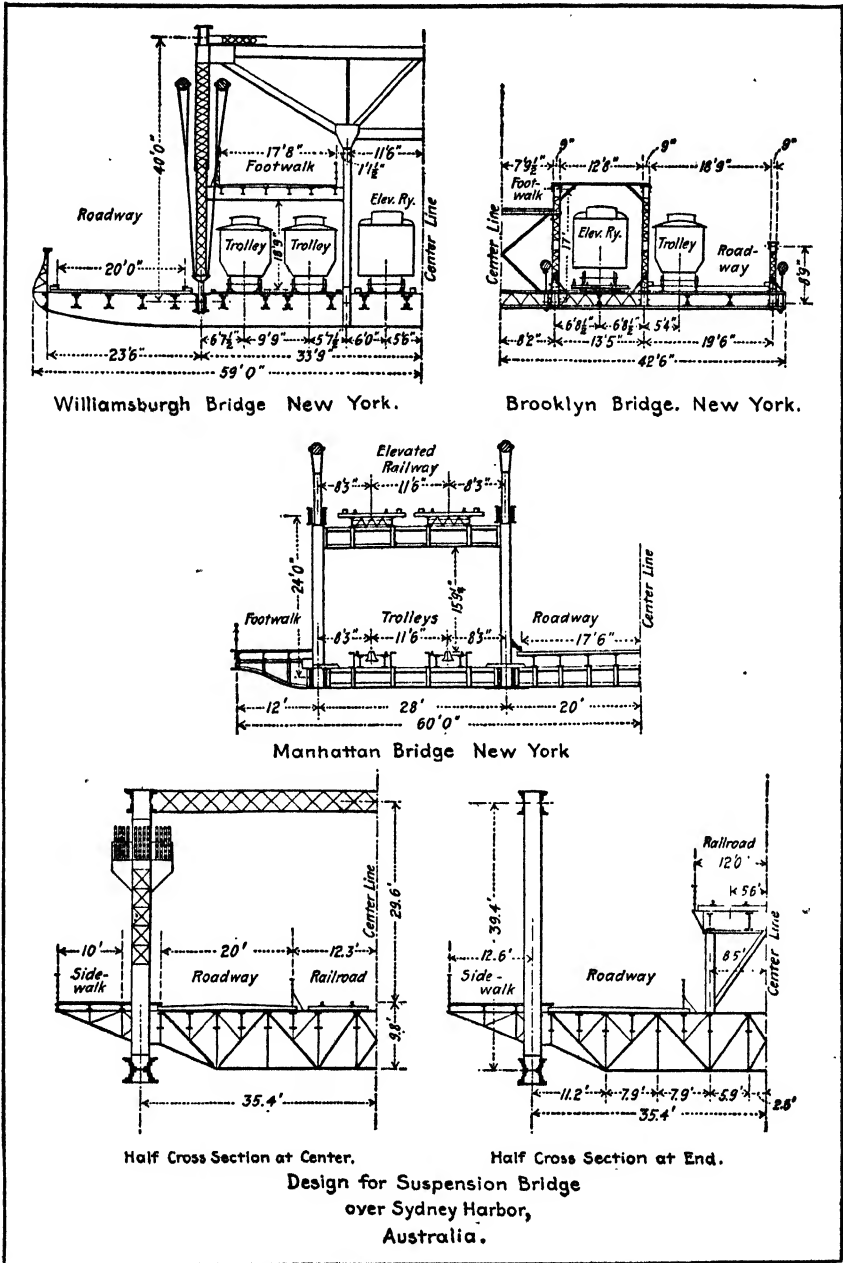

FIG. 24.—Cross-sections of suspension bridges.

At the anchorage, the cable is separated into its component strands; the latter diverge slightly to make room for the "strand shoes" which are grooved castings of horseshoe shape around which the respective strands are looped. The shoes are pin-connected to the anchorage eyebars which are prepared in advance of the cable spinning.

When the cables are compacted, the "cable bands" are affixed for connection of the suspenders. The bands are steel castings, made in two halves, with outstanding flanges for bolting together so as to secure the necessary frictional resistance to sliding. Flanged grooves around the bands receive the suspender ropes. The cable between the bands is later given its protective wrapping.

12. Twisted Wire Ropes.—For smaller spans, up to 600 or 700 ft., twisted wire ropes will generally be preferable to parallel wire cables (*e.g.* Fig. 25). Such ropes are prepared at the mill and shipped on drums. They are hauled across the span (by means of lighter temporary carrier cables) and secured at the anchorages; each rope end is expanded and fixed in a steel socket which may be threaded for adjusting the rope to exact position. Shim pieces between sockets and anchor plate may also be used to regulate the rope lengths.

Twisted wire ropes are also used for suspenders (Figs. 21, 22, 23).

The ropes are made up to $2\frac{1}{2}$ in. diameter of round wire in spiral lay. For larger diameters, a twisted wire cable is formed by laying six twisted wire strands spirally around a central strand. Ordinarily the twist of the wires into strands is opposite in direction to the twist of the strands into rope.

Twisted wire ropes possess considerable flexibility, particularly when successive layers of wires have alternate directions of twist.

Patent "locked wire ropes" are now made in which the core wires are surrounded by wires of trapezoidal section, and these in turn by wires having a special interlocking section. This construction gives compactness, protection against entrance of moisture and against loosening of the outer wires. A good coat of paint affords ample rust protection.

In twisted wire rope, on account of the spiral lay of the wires surrounding the core, the coefficient of elasticity E is less than in straight wires by 15 to 30 per cent if made up of round wires, and by 10 to 15 per cent if composed of patent locked wires.

The combined tensile strength of the wires is also reduced by the twisting into rope. For a single strand rope, the reduction of strength is 15 per cent figured on net metallic section, and 25 per cent figured on gross circular section. For a seven strand rope, the reduction of strength is 18 per cent on net metallic section and 48 per cent on gross circular section. For ropes of patent locked wire, the corresponding reductions are 7, 11, 15 and 35 per cent.

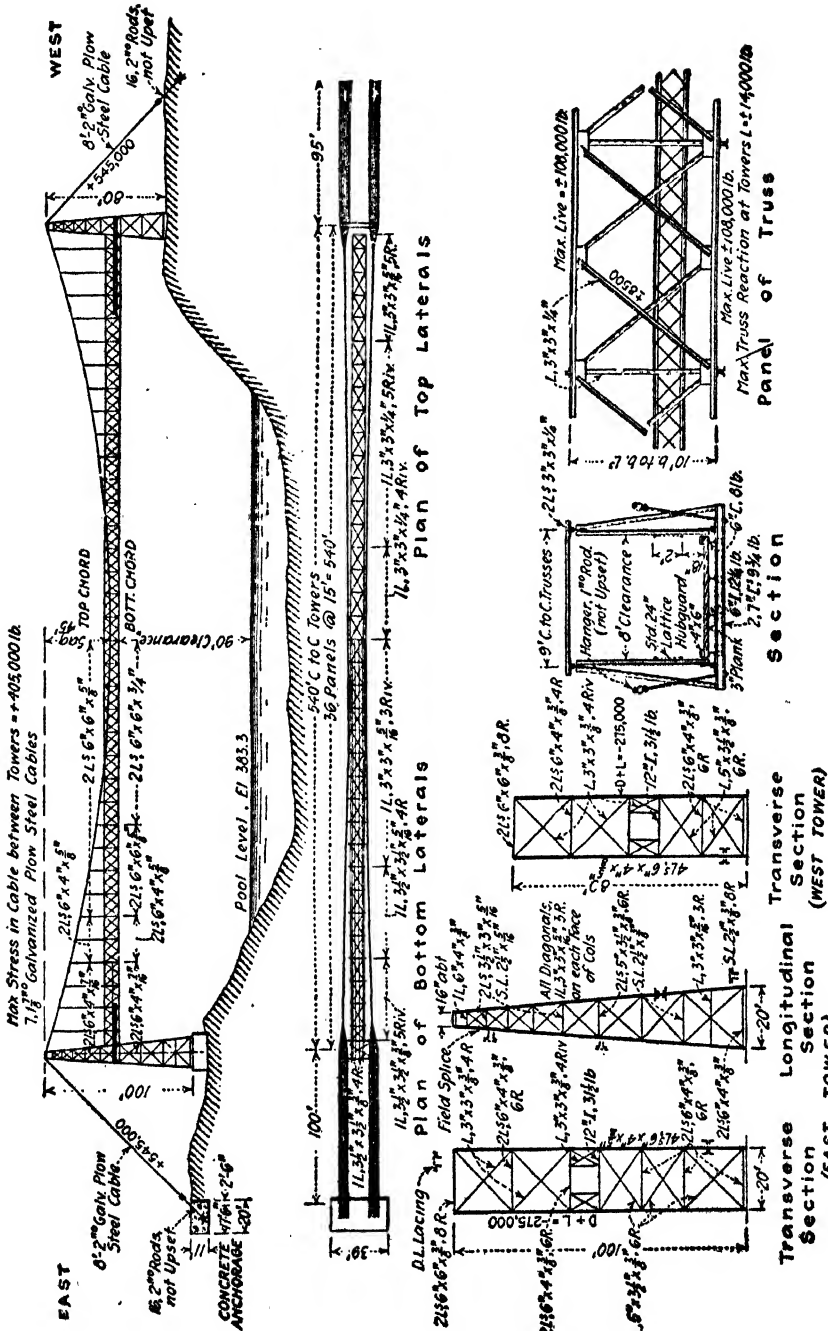

FIG. 25.—General dimensions and sections of 540-foot suspension bridge over Cumberland River.

Galvanized steel suspension bridge rope (used for suspenders and for small cables) has a tested ultimate strength (pounds) given by $80,000 \times (\text{diameter})^2$. The weight of the rope, in pounds per lineal foot, is given by $1.68 \times (\text{diameter})^2$.

13. Towers.—The design of the tower depends upon the material employed. This is either masonry or, more generally, steel. If masonry is used, the tower may consist of shafts springing from a common base beneath the roadway and connected together at the top with gothic arches (Fig. 21). If steel is used, the tower consists of a column or tower leg for each suspension system (Figs. 22, 23, 25, 26, 27). For lateral stability, the tower legs are braced together by means of cross-girders and cross-bracing (Figs. 22, 23, 25, 27), or by arched portals

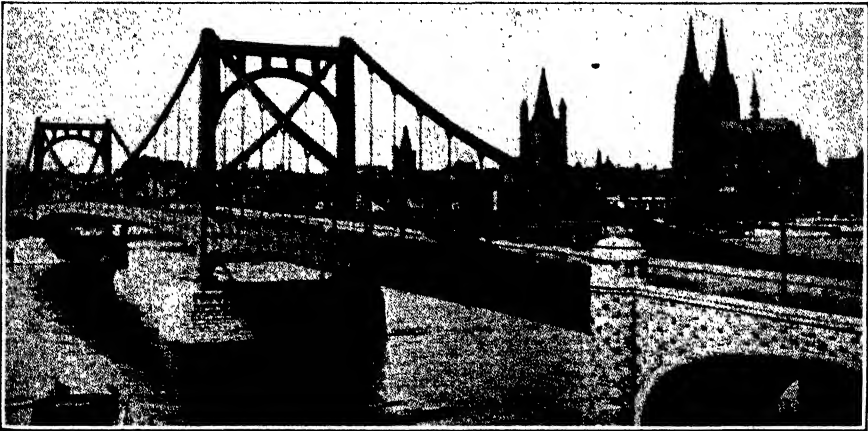

Fig. 26.—Cologne Chain Bridge—1915—Span 605 ft.—Type OS.

(Fig. 26). The sway and portal bracing are necessary to brace the columns against buckling, to take care of lateral components from cradled cables or chains, and to carry wind stresses down to the piers.

Steel tower columns (Fig. 23) are made up of plates and angles to form either open or closed cross-sections; horizontal diaphragms at proper intervals stiffen the section. The cross-section enlarges toward the base which is anchored to resist the horizontal forces.

For high towers, the individual legs may be made of braced tower construction, each leg consisting of four columns spreading apart toward the base and connected with cross-bracing (Fig. 22).

Instead of anchoring the base, a rocker-tower construction may be secured by providing hinge-action at the base (Fig. 26). This may be accomplished by use of a pin-bearing, a segmental base, or a concave roller nest.

14. Saddles.—On the tower top, the cable rests in a special casting called a saddle. This may rest on rollers to permit longitudinal move-

ment from changes in cable length, or it may be bolted to the towers. In the latter case, the tower has to take up the movement—by bending if fixed at the base, and by pivoting if hinged at the base.

The radius of curvature of the cable in the saddle should be large in order to avoid excessive bending stresses in the wires and strands.

If the cables are "cradled" (hung off the vertical), the saddles must be inclined accordingly; and the cable laying should be conducted so as to avoid torsional effects.

At points where cable or chain changes direction at the anchorage, a saddle or knuckle support is required, with provision for movement by rocker hinge, rollers, or sliding.

The tower saddles in long span bridges have generally been provided with rollers (*e.g.*, Brooklyn, Williamsburgh). For the Manhattan Bridge (1909) fixed saddles were adopted, despite the fact that large bending stresses are thereby caused in the tower. The objections to movable saddles are uncertainty of operation of the rollers, liability to clog or rust, and necessity for scrupulous maintenance under conditions conducive to neglect. Rocker or pin-bearing towers (Fig. 26) appear to afford the most economical and scientific solution of the problem.

Where chains are used instead of wire cables, the saddle support is generally of the rocker type—the entire tower acting as a rocker (Fig. 26), or else anchored and carrying a smaller rocker on its top (Fig. 27). The latter rocker is pin-connected at its lower end to the tower and at its upper end to the eyebar chains.

15. Anchorages.—At the anchorage the cable strands loop around their respective shoes which are pin-connected to the anchor chains. The latter extend in straight, broken or curved lines, as the case may be, to their final pin-connection to anchor plate, girders, or grillage bearing against the masonry (Fig. 27).

Cables of twisted wire rope may be anchored directly without the use of eyebar chains. The rope ends are secured in sockets which bear against the anchor girders.

The anchorage masonry serves the function of taking up the pull of the cable or chain and transmitting it to the foundation. By graphic composition of the external applied forces with the weights of the sections of masonry, the resultant lines of pressure are determined and followed through to the foundation. First class masonry is provided where the stresses demand it, and the remainder of the mass may be made up of lean concrete or other filling material serving only to provide weight.

In designing, a factor of safety of two is generally adopted against uplift, sliding or tilting of the anchorage. For important structures, the foundation should be on sound rock. The coefficient of friction is taken as 0.5 to 0.6.

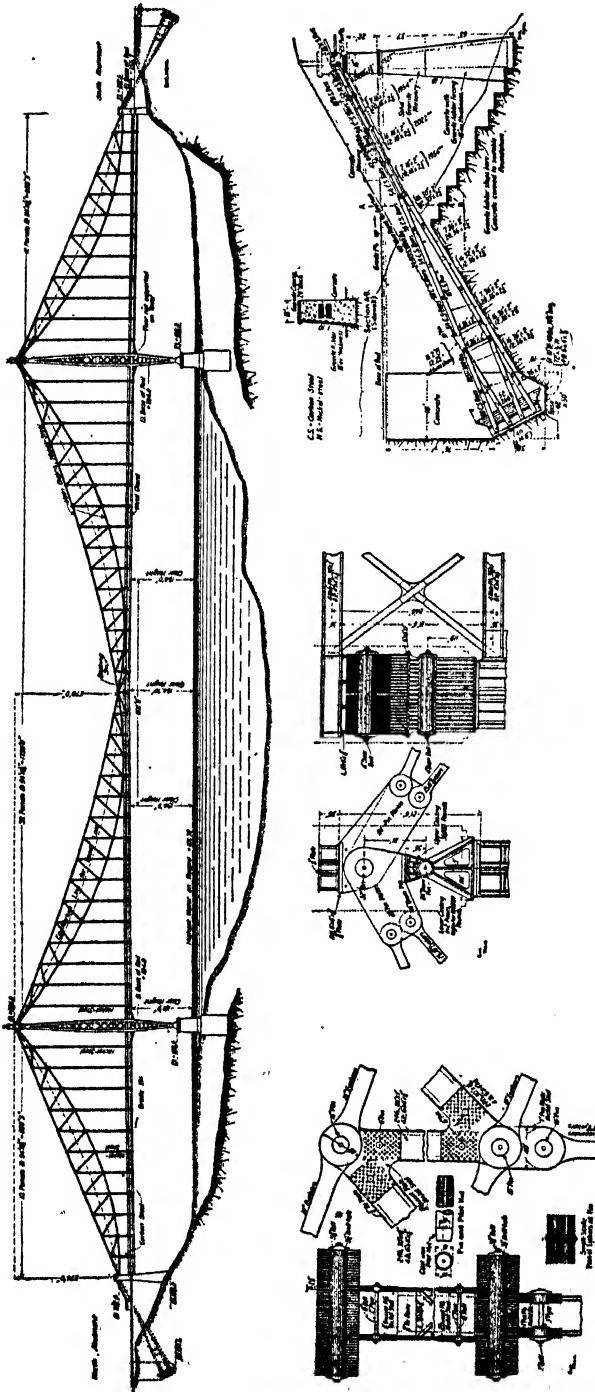

FIG. 27.—Design for Quebec Bridge—1910—Span 1,758 ft.—Type 3BS.

Consideration should be given in the design of the anchorage to protection against rust, accessibility for inspection and maintenance, and possibility of replacement of parts. French practice lays great stress on ease of replacement: The cables are composed of a number of twisted wire ropes which are individually renewable, all rope ends are socketed, endless ropes are eliminated, and all steel in the anchorage is accessible. American practice emphasizes protection (and permanence) rather than replaceability: Parallel wire cables prevail, the cables are covered with moisture proof wrapping, the only exposed portions being at the loop ends where, however, individual wires can be inspected and cleaned. The danger point for rust is in the anchorage, and there we generally substitute chain for cable. The steel in the anchorage pit is generally surrounded with concrete or other waterproofing material in order to exclude water.

DESIGN CALCULATIONS FOR TWO-HINGED SUSPENSION BRIDGE WITH SUSPENDED SIDE SPANS (TYPE 2S)

16. Dimensions.—The following dimensions are given:

l = main span = 1,080 ft.	$(l' = l)$	
l_1 = side span = 360 ft.		$r = \frac{l_1}{l} = \frac{1}{3}$
f = cable sag in main span = 108 ft.		$n = \frac{f}{l} = \frac{1}{10}$
f_1 = cable sag in side span = 12 ft.		$n_1 = \frac{f_1}{l_1} = \frac{1}{30}$
l_2 = distance, tower to anchorage = 400 ft		$v = \frac{f_1}{f} = \frac{1}{9}$
d = depth of stiffening truss = 22.5 ft.		

Mean chord section (gross): Main span, top = 83, bottom = 137 sq. in.
 Side spans, top = 52, bottom = 52 sq. in.

I (Main span) = $83(14)^2 + 137(8.5)^2 = 26,200 \text{ in.}^2 \text{ ft.}^2$
 I_1 (Side spans) = $(2)(52)(11.25)^2 = 13,100 \text{ in.}^2 \text{ ft.}^2$
 $i = \frac{I}{I_1} = 2.0$

Width, center to center of trusses or cables = 42.5 ft.

A = cable section = 78 sq. in. per cable ($A_1 = A$)

$\tan \alpha$ = slope of cable chord in main span = 0

$\tan \alpha_1$ = slope of cable chord in side span = $4(n - n_1) = 0.267$

$\sec \alpha_1 = 1.034$

$\tan \varphi_1 = 4n = 0.4 \quad \sec \varphi_1 = 1.08$

17. Stresses in Cable.—(All values given per cable.)

Given: w = dead load (including cable) = 2,385 lb. per lin. ft.

p' = live load = 860 lb. per lin. ft.

t = temperature variation = $\pm 60^\circ \text{ F.}$ ($Ewt = 11,720 \text{ lb. per sq. in.}$)

For dead load, by Eq. (5), p. 290, the horizontal component of cable stress is

$$H = \frac{wl^2}{8f} = \frac{10}{8}wl = 3,220 \text{ kips (1 kip = 1,000 lb.)}$$

For live load, by Eq. (85), the denominator of the H -equation is

$$N = \frac{8}{5}(1 + 2irv^2) + \frac{3I}{Af^2} \cdot \frac{l'}{l}(1 + 8n^2) + \frac{6I}{A_1f^2} \cdot \frac{l_2}{l} \cdot \sec^3 \alpha_1(1 + 8n_1^2) = 1.626 + 0.093 + 0.071 = 1.790$$

By Eq. (94), the horizontal tension produced by live load covering all three spans will be

$$H = \frac{1}{5Nn}(1 + 2ir^3v)p'l = \frac{2}{1.790}(1.0164)(9,300) = 1,050 \text{ kips}$$

The total length of cable between anchorages is given by Eq. (114):

$$\frac{L}{l} = \left(1 + \frac{8}{3}n^2\right) + 2\frac{l_2}{l} \left(\sec \alpha_1 + \frac{8}{3} \frac{n_1^2}{\sec^3 \alpha_1}\right) = 1.027 + 0.767 = 1.794$$

Then, for temperature, by Eq. (116),

$$H_t = - \frac{3EI\omega tL}{f^2Nl} = \frac{3(11,720)(26,200)(1.794)}{(108)^2(1.790)} = \mp 80 \text{ kips}$$

Adding the values found for H :

D.L.....	3,220 kips
L.L.....	1,050
Temp.....	80
	4,350

we obtain, Total H = 4,350 kips per cable.

The maximum tension in the cable is, by Eq. (3),

$$T_1 = H \cdot \sec \varphi_1 = H(1.08) = 4,700 \text{ kips}$$

At 60,000 lb. per sq. in., the cable section required is:

$$4,700 \div 60 = 78 \text{ sq. in. per cable (as given).}$$

18. Moments in Stiffening Truss. Main Span.

Live load = p = 1,600 lb. per lin. ft.

(All values given and calculated are per truss)

With the three spans completely loaded, the bending moment at any section x of the main span is given by Eq. (96):

$$\text{Total } M = \frac{1}{2}px(l - x) \left[1 - \frac{8}{5N}(1 + 2ir^3v)\right] = \frac{1}{2}px(l - x)[0.091]$$

Hence only 9.1 per cent of the full live load is carried by the stiffening truss. Accordingly, at the center,

$$\text{Total } M = 0.091 \frac{pl^2}{8} = + 21,200 \text{ ft.-kips}$$

At other points, the values of M are proportional to the ordinates of a parabola. They are obtained as follows:

SECTION	PARABOLIC COEFFICIENT	TOTAL M
$\frac{x}{l} = 0$	$(4)(0)(1.0) = 0$	0
0.1	$(4)(0.1)(0.9) = 0.36$	+ 7,600
0.2	$(4)(0.2)(0.8) = 0.64$	+13,600
0.3	$(4)(0.3)(0.7) = 0.84$	+17,800
0.4	$(4)(0.4)(0.6) = 0.96$	+20,400
0.45	$(4)(0.45)(0.55) = 0.99$	+21,000
0.5	$(4)(0.5)(0.5) = 1.00$	+21,200 ft.-kips

For maximum and minimum moments, the critical points are found by solving Eq. (98):

$$C(k) = N \cdot n \cdot \frac{x}{y} = 0.179 \frac{x}{y}$$

with the aid of Table 1 or Fig. 11:

$\frac{x}{l}$	$\frac{y}{l}$	$\frac{x}{y}$	$C(k)$	k	$D(k)$
0	0	(2.50)	(0.448)	(0.364)	(0.508)
0.1	0.036	2.78	0.498	0.402	0.411
0.2	0.064	3.12	0.559	0.448	0.310
0.3	0.084	3.57	0.640	0.512	0.202
0.4	0.096	4.17	0.747	0.603	0.095
0.45	0.099	4.55	0.815	0.667	0.050 + 0.000
0.5	0.100	5.00	0.895	0.755	0.016 + 0.016
0.55	0.099	5.55	0.995	0.950	0.000 + 0.050

The values of $D(k)$, found from Table 1 or Fig. 11, are recorded in the above tabulation. For all sections from $x = \frac{N}{4} \cdot l = 0.447l$ to $x = 0.553l$ there are double values of $D(k)$ explained under Eq. (100).

The values of the minimum moments are then given by Eq.(99):

$$\text{Min. } M = -\frac{2px(l-x)}{5N} [D(k) + 4ir^3v] = -417,000 \frac{x}{l} \left(1 - \frac{x}{l}\right) [D(k) + 0.033]$$

and the maximum moments are then given by Eq. (101):

$$\text{Max. } M = \text{Total } M - \text{Min. } M$$

SECTION	$\frac{x}{l} \left(1 - \frac{x}{l}\right)$	$[D(k) + 0.033]$	MIN. M	MAX. M
$\frac{x}{l} = 0$	0	(0.541)	0	0
0.1	0.09	0.444	- 16,700	+ 24,300
0.2	0.16	0.343	- 22,900	+ 36,500
0.3	0.21	0.235	- 20,600	+ 38,400
0.4	0.24	0.128	- 12,800	+ 33,200
0.45	0.248	0.083	- 8,600	+ 29,600
0.5	0.25	0.065	- 6,800	+ 28,000 ft.-kips

Dividing the maximum and minimum moments by the truss depth ($d = 22.5$), we obtain the respective chord stresses. Adding the temperature and wind stresses, and dividing by the specified unit stresses, the required chord sections will be obtained.

19. Bending Moments in Side Spans.

$$(p = 1,600 \text{ lb. per lin. ft. per truss})$$

With all three spans completely loaded, the bending moment at any section x_1 of the side span is given by Eq. (97):

$$\text{Total } M_1 = \frac{1}{2}px_1(l_1 - x_1) \left[1 - \frac{8}{5N} (1 + 2ir^3v) \frac{v}{r^2} \right] = \frac{1}{2} px_1(l_1 - x_1)[0.091]$$

Accordingly, at the center,

$$\text{Total } M_1 = 0.091 \frac{pl_1^2}{8} = +2,300 \text{ ft.-kips}$$

There are no critical points for moments in the side spans. The minimum moments are given by Eq. (102):

$$\text{Min. } M_1 = -y_1 \cdot \frac{1 + ir^3v}{5Nn} \cdot pl = -y_1(1.124)pl$$

Accordingly, at the center,

$$\text{Min. } M_1 = -12(1.124)(1,730) = -23,400 \text{ ft.-kips}$$

The maximum moments are given by Eq. (103):

$$\text{Max. } M_1 = \text{Total } M_1 - \text{Min. } M_1$$

Accordingly, at the center,

$$\text{Max. } M_1 = +2,300 + 23,400 = +25,700 \text{ ft.-kips}$$

At other sections, the moments are proportional to the ordinates of a parabola:

	SECTION	PARABOLIC COEFFICIENT	TOTAL M_1	MIN. M_1	MAX. M_1
$\frac{x_1}{l}$ =	0	0	0	0	0
	0.1	0.36	+ 800	- 8,400	+ 9,200
	0.2	0.64	+1,500	-15,000	+16,500
	0.3	0.84	+1,900	-19,600	+21,500
	0.4	0.96	+2,200	-22,400	+24,600
	0.5	1	+2,300	-23,400	+25,700 ft.-kips

20. Shears in Stiffening Truss—Main Span.

$$(p = 1,600 \text{ lb. per lin. ft.})$$

With the three spans completely loaded, the shear at any section x of the main span is given by Eq. (104):

$$\text{Total } V = \frac{1}{2}pl(l - 2x) \left[1 - \frac{8}{5N} (1 + 2ir^3v) \right] = \frac{1}{2}p(l - 2x)[0.091]$$

The shears will be the same as would be produced by loading the span with 9.1 per cent of the actual load, or with $0.091pl = 157$ kips. Total $V = 157 \left(\frac{1}{2} - \frac{x}{l} \right)$:

SECTION	$\frac{1}{2} - \frac{x}{l}$	TOTAL V
$\frac{x}{l} = 0$	0.5	+79 kips
0.1	0.4	+63
0.2	0.3	+47
0.3	0.2	+31
0.4	0.1	+16
0.5	0	0

The maximum shears are given by Eq. (106):

$$\text{Max. } V = \frac{1}{2}pl \left(1 - \frac{x}{l} \right)^2 \left[1 - \frac{8}{N} \left(\frac{1}{2} - \frac{x}{l} \right) \cdot G \left(\frac{x}{l} \right) \right]$$

where the values of $G \left(\frac{x}{l} \right)$ are taken from Table 1 or Fig. 11. The shears are obtained as follows:

$$\left(\frac{1}{2}pl = 864 \text{ kips} \right)$$

SECTION	$\frac{8}{N} \left(\frac{1}{2} - \frac{x}{l} \right)$	$G \left(\frac{x}{l} \right)$	—	$\left(1 - \frac{x}{l} \right)^2$	MAX. V
$\frac{x}{l} = 0$	2.23	0.400	0.107	1	+ 92 + 194
0.1	1.79	0.482	0.136	0.81	+ 95 + 96
0.2	1.34	0.565	0.243	0.64	+134 + 22
0.3	0.89	0.647	0.424	0.49	+179
0.4	0.45	0.726	0.673	0.36	+210
0.5	0	0.800	1.000	0.25	+216 kips

For all sections $x < \frac{l}{2} \left(1 - \frac{N}{4} \right) = 0.277l$, the loading for maximum shear extends from the given section x to a critical point kl defined by Eq. (108):

$$C(k) = \frac{N}{4} \cdot \frac{l}{l - 2x} = \frac{0.446}{1 - \frac{2x}{l}}$$

The values $C(k)$ are solved for k with the aid of Fig. 11:

SECTION	$1 - \frac{2x}{l}$	$C(k)$	k
0	1	0.446	0.362
0.1	0.8	0.558	0.448
0.2	0.6	0.744	0.600

For these sections, a correction is to be added to the values of Max. V found above. This additional shear is given by Eq. (109):

$$\text{Add. } V = \frac{1}{2}pl(1 - k)^2 \cdot \left[\frac{8}{N} \left(\frac{1}{2} - \frac{x}{l} \right) \cdot G(k) - 1 \right]$$

SECTION	k	$(1 - k)^2$	$\frac{8}{N} \left(\frac{1}{2} - \frac{x}{l} \right)$	$G(k)$	[—]	Add. V
$\frac{x}{l} = 0$	0.362	0.407	2.23	0.696	0.552	+ 194
0.1	0.448	0.305	1.79	0.762	0.365	+ 96
0.2	0.600	0.160	1.34	0.866	0.160	+ 22 kips

The minimum shears are then given by Eq. (112):

$$\text{Min. } V = \text{Total } V - \text{Max. } V.$$

SECTION	TOTAL V	MAX. V	MIN. V
$\frac{x}{l} = 0$	+ 79	+ 286	- 207
0.1	+ 63	+ 191	- 128
0.2	+ 47	+ 156	- 109
0.3	+ 31	+ 179	- 148
0.4	+ 16	+ 210	- 194
0.5	0	+ 216 kips	- 216 kips

21. Shears in Side Spans.

$$(p = 1,600 \text{ lb. per lin. ft., } l_1 = 360 \text{ ft.})$$

With the three spans completely loaded, the shear at any section x_1 in the side spans will be, by Eq. (105):

$$\text{Total } V_1 = \frac{1}{2}p(l_1 - 2x_1) \left[1 - \frac{8}{5N} \frac{v}{r^2} (1 + 2ir^3v) \right] = pl_1 \left(\frac{1}{2} - \frac{x_1}{l_1} \right) [0.091]$$

Since $l_1 = \frac{1}{3}l$, these shears will be one-third of the corresponding values in the main span:

SECTION	TOTAL V_1
$\frac{x_1}{l_1} = 0$	+ 26 kips
0.1	+21
0.2	+16
0.3	+10
0.4	+ 5
0.5	0

There are no critical points for shear in the side spans. The maximum shear at any section x_1 is given by Eq. (111):

$$\text{Max. } V_1 = \frac{1}{2}pl_1 \left(1 - \frac{x_1}{l_1}\right)^2 \left[1 - \frac{8}{N}ivv^2 \left(\frac{1}{2} - \frac{x_1}{l_1}\right) \cdot G\left(\frac{x_1}{l_1}\right)\right]$$

SECTION	$\frac{8}{N}ivv^2 \left(\frac{1}{2} - \frac{x_1}{l_1}\right)$	$G\left(\frac{x_1}{l_1}\right)$	[—]	$\left(1 - \frac{x_1}{l_1}\right)^2$	MAX. V_1
$\frac{x_1}{l_1} = 0$	0.0183	0.400	0.993	1	+286 kips
0.1	0.0147	0.482	0.993	0.81	+232
0.2	0.0110	0.565	0.994	0.64	+183
0.3	0.0073	0.647	0.995	0.49	+140
0.4	0.0037	0.726	0.997	0.36	+103
0.5	0	0.800	1.000	0.25	+ 72

The minimum shears in the side spans are given by Eq. (113):

$$\text{Min. } V_1 = \text{Total } V_1 - \text{Max. } V_1$$

SECTION	MIN. V_1
$\frac{x_1}{l_1} = 0$	-260 kips
0.1	-211
0.2	-167
0.3	-130
0.4	- 98
0.5	- 72

22. Temperature Stresses.

$$(H_t = \mp 80 \text{ kips})$$

The stresses in the main span from temperature variation are figured with the aid of Eqs. (117) and (118):

$$M_t = -H_t \cdot y$$

$$V_t = -H_t(\tan \varphi - \tan \alpha). \quad (\text{Here, } \tan \alpha = 0)$$

The temperature moments in the side spans are given by the formula:

$$M_t = -H_t \cdot y_1$$

and will therefore be v ($= \frac{1}{9}$) times the corresponding main span values.

SECTION	PARABOLIC COEFFICIENT	M_t
$\frac{x_1}{l_1} = 0$	0	0
0.1	0.36	± 350
0.2	0.64	± 610
0.3	0.84	± 810
0.4	0.96	± 920
0.5	1	$\pm 960 \text{ ft.-kips}$

The temperature shears in the side spans are given by the formula:

$$V_t = -H_t \cdot (\tan \varphi_t - \tan \alpha_1). \quad (\text{Here, } \tan \alpha_1 = 0.267.)$$

They will be $\frac{n}{n_1}$ ($= \frac{1}{3}$) times the corresponding main span values:

SECTION	Tan $\varphi_t - \tan \alpha_1$	V_t
$\frac{x_1}{l_1} = 0$	$4n_1 = 0.133$	± 11 kips
0.1	0.106	± 8
0.2	0.080	± 6
0.3	0.053	± 4
0.4	0.027	± 2
0.5	0	0

23. Wind Stresses in Bottom Chords.—

(Assumed wind load = $p = 400$ lb. per lin. ft.)

If the lateral bracing is in the plane of the bottom chords, these will act as the chords of a wind truss. The applied wind pressure p is partly counteracted by a force of restitution r due to the horizontal displacement of the weight of the stiffening truss w . The resulting reduction in the effective horizontal load is given with sufficient accuracy by the formula

$$r = \frac{0.013 \frac{wl^4}{vEI}}{1 + 0.013 \frac{wl^4}{vEI}}$$

In this case, $w =$ total dead load, both trusses, = 4,770 lb. per lin. ft.; $v =$ vertical height from cable chord to center of gravity of the dead load = 130 ft.; $I =$ moment of inertia of wind truss = $\frac{1}{2}(137)(42.5)^2 = 124,000$ in.² ft.² Substituting these values, we obtain

$$\frac{r}{p} = \frac{0.173}{1 + 0.173} = 0.147$$

Hence the force of restitution r (due to the obliquity of suspension after horizontal deflection) amounts, in this case to 14.7 per cent of the applied wind load p at the center of the span. The force r diminishes to zero at the ends of the span, and the equivalent uniform value of r may be taken as five-sixths of the mid-span value. The resultant horizontal load on the span is

$$p - \frac{5}{6}r = 400 - \frac{5}{6}(59) = 351 \text{ lb. per lin. ft.}$$

Treating this value as a uniform load, the bending moment at the center is

$$M_w = \frac{351l^2}{8} = \pm 51,000 \text{ ft.-kips}$$

¹ For the derivation of this formula, see STEINMAN, "Suspension Bridges and Cantilevers," p. 76, D. Van Nostrand Co., 1913.

Dividing by the truss width 42.5 ft., we obtain the chord stress = $\pm 1,200$ kips at mid-span. The wind stresses at other sections will be proportional to parabolic ordinates, being zero at the ends of the span.

The shears in the lateral system may also be calculated for the resultant uniform load of 351 lb. per lin. ft. The end shears will be

$$V_w = \frac{351l}{2} = \pm 190 \text{ kips}$$

In the side spans, unless they exceed 1,000 ft. in span length, the reduction in effective wind pressure may be neglected. (In this example, $\frac{r}{p}$ would amount to only 1 per cent.) Hence, the moments and shears are calculated for the full specified wind load of 400 lb. per lin. ft., acting on simple spans 360 ft. in length.

24. Design of Tower.—Each tower of this bridge consists of two columns of box section, stiffened with internal diaphragms, and rigidly tied together with transverse bracing in a vertical plane. Each tower column is 225 ft. high and is made of a double box section, 42.5 in. wide. The other dimension d , parallel to the stiffening truss, is 4 ft. at the top, increasing to 9 ft. at the base. The walls are $1\frac{1}{4}$ in. thick (made up of $\frac{5}{8}$ -in. plates and corner angles) and the vertical transverse diaphragm is $\frac{5}{8}$ in. thick. Splices are provided at such intervals as to keep the individual sections within specified limitations of length or weight for shipment. Horizontal diaphragms are provided at splices and, in general, at 10-ft. intervals.

The tower columns are battered so as to clear the trusses. They are 42.5 ft. center to center at the top and 53.5 ft. center to center at the base.

25. Movement of Top of Tower.—The towers are assumed fixed at the base, and the cable saddles immovable with respect to the tower.

The maximum fiber stress in the tower columns will occur when the live load covers the main span and the farther side span at maximum temperature. Under this condition of loading, the top of the tower will be deflected toward the main span as a result of the following deformations:

- (1) The upward deflection (Δf_1) at the center of the unloaded side span.
- (2) The elongation of the cable between the anchorage and the tower due to the elastic strain produced by the applied loads.
- (3) The elongation of the cable due to thermal expansion. These deformations are computed as follows:

$$\text{(Live load} = p' = 860 \text{ lb. per lin. ft. } H = 1,040 \text{ kips)}$$

- (1) The upward deflection Δf_1 is found by considering the unloaded

side span as a simple beam subjected to an upward loading equal to the live load suspender tensions (Eq. (55)):

$$s = \frac{8f}{l^2} \cdot H = \frac{8}{10} \cdot \frac{1,040}{1,080} = 770 \text{ lb. per lin. ft. per truss}$$

$$\Delta f_1 = \frac{5}{384} \cdot \frac{s l_1^4}{EI_1} = 0.428 \text{ ft.}$$

(2) The elastic elongation of the cable in the side span is, by Eq. (51),

$$\Delta L_1 = \frac{H l_2}{EA} \left(1 + \frac{16}{3} n_1^2 + \tan^2 \alpha_1 \right) = 0.178 (1.077) = 0.192 \text{ ft.}$$

(3) The temperature expansion of the cable in the side span is, by Eqs. (50) and (19),

$$\Delta L_1 = \omega l_2 \left(\sec \alpha_1 + \frac{8}{3} \cdot \frac{n_1^2}{\sec^3 \alpha_1} \right) = 0.156(1.037) = 0.162 \text{ ft.}$$

We also have,

$$\frac{\Delta L_1}{\Delta l_1} = \sec \alpha_1 + \frac{8}{3} \cdot \frac{n_1^2}{\sec^3 \alpha_1} = 1.037$$

$$\frac{\Delta L_1}{\Delta f_1} = \frac{16}{3} \cdot \frac{n_1}{\sec^3 \alpha_1} = 0.160$$

The deflection of the top of the tower is then given by

$$y_0 = \Delta l_1 = \frac{\Delta l_1}{\Delta L_1} \cdot \frac{\Delta L_1}{\Delta f_1} \cdot \Delta f_1 + \frac{\Delta l_1}{\Delta L_1} \cdot \Sigma (\Delta L_1)$$

Substituting the values just calculated, we obtain the maximum tower deflection:

$$y_0 = \frac{0.160}{1.037} (0.428) + \frac{1}{1.037} (0.192 + 0.162) = 0.408 \text{ ft.}$$

26. Forces Acting on Tower.—Considering the above deflection y_0 as produced by an unbalanced horizontal force P applied at the top of the tower, this force may be calculated, if the sectional dimensions of the tower are known, by the formula

$$y_0 = \frac{P}{E} \cdot \Sigma \left(\frac{x^2}{I} \cdot \Delta x \right)$$

In the present case, we find $\Sigma \frac{x^2}{I} \cdot \Delta x = 1,740$. Hence,

$$P = y_0 \frac{E}{1,740} = 17,200 y_0 = 7,000 \text{ lb. per column.}$$

The other loads acting on the tower are the vertical reaction V at the saddles, and the end-shears V_1 at the points of support of the stiffening truss. The saddle reaction is given by the formula:

$$V = 2H \tan \varphi = (2)(4,340)(0.4) = +3,470 \text{ kips per column}$$

The truss reaction, with all spans loaded and maximum temperature rise, is

$$V_1 = (42 + 32) + (14 + 11) = +99 \text{ kips per column}$$

With one side span unloaded, as assumed above,

$$V_1 = (45 + 32) + (11 - 140) = -52 \text{ kips per column}$$

It will be on the safe side to neglect this uplift V_1 ; so that the column need be figured only for the horizontal load P and the vertical load V .

At any section x of the tower (measured downward), the horizontal deflection y from the initial vertical position of the axis is given with sufficient accuracy by the equation for the elastic curve of the cantilever:

$$y = y_0 \left[1 - \frac{3}{2} \left(\frac{x}{h} \right) + \frac{1}{2} \left(\frac{x}{h} \right)^3 \right]$$

27. Calculation of Stresses in Tower.—The resulting extreme fiber stresses at any section of the tower will be:

$$\text{Combined stress} = \frac{V}{A} + \frac{Pxc}{I} + \frac{V(y_0 - y)c}{I}$$

The computations may be arranged as follows, the stresses being figured for convenience at 25-ft. intervals:

Joint	x (ft.)	$y_0 - y$ (ft.)	$d = 2c$ (ft.)	A (sq. in.)	I (in. ² ft ² .)	$\frac{x^2}{I}$	$\frac{V}{A}$	$\frac{Pxc}{I}$	$\frac{V(y_0 - y)c}{I}$	Combined stress (lb. per sq. in.)
0	0	0	4.0	280	560	0	12,400	0	0	12,400
1	25	0.068	4.5	295	730	0.86	11,800	500	700	13,000
2	50	0.134	5.0	310	940	2.66	11,200	900	1,100	13,200
3	75	0.197	5.5	325	1,170	6.40	10,700	1,200	1,600	13,500
4	100	0.254	6.0	340	1,440	6.94	10,200	1,500	1,800	13,500
5	125	0.305	6.5	355	1,740	8.98	9,800	1,600	2,000	13,400
6	150	0.348	7.0	370	2,080	10.80	9,400	1,800	2,000	13,200
7	175	0.380	7.5	385	2,460	12.42	9,000	1,900	2,000	12,900
8	200	0.400	8.0	400	2,880	13.88	8,700	1,900	1,900	12,500
9	225	0.408	9.0	430	3,850	13.20	8,100	1,800	1,700	11,600
						$\Sigma = 69.54$				

28. Wind Stresses in Tower.—To the above tower stresses produced by live load and temperature, must be added the stresses due to wind loads.

The truss wind load of 400 lb. per lin. ft. produces a horizontal reaction at each tower of

$$360 \frac{l}{2} + 400 \frac{l_1}{2} = 266 \text{ kips}$$

This acts at Joint 4 ($x = 100$).

The deflection of suspended truss under wind load produces at the top of each tower a horizontal reaction of $40 \frac{l}{2}$; and the wind on the surface of the cables produces an addition to this reaction amounting to $10 \left(\frac{l}{4} + \frac{l_1}{2} \right)$; hence the total reaction at the tower top = 26 kips.

The wind acting directly on the tower is assumed at 25 lb. per sq. ft. of vertical elevation. This produces, at each joint, an equivalent concentrated load of $25 \times (25d)$.

Joint	x (ft.)	d (ft.)	Wind load (kips)	Shear (kips)	Moment (ft.-kips)	Column distance (ft.)	A (sq. in.)	Stress from W.L. (lb. per sq. in.)	Stress from L.L. + tem- perature (lb. per sq. in.)	Total stress (lb. per sq. in.)
0	0	4.0	27	0	0	42.5	280	0	12,400	12,400
1	25	4.5	3	27	675	43.5	295	100	13,000	13,100
2	50	5.0	3	30	1,425	44.5	310	100	13,200	13,300
3	75	5.5	3	33	2,250	46.5	325	100	13,500	13,600
4	100	6.0	270	36	3,150	48.5	340	200	13,500	13,700
5	125	6.5	4	306	10,800	49.5	355	600	13,400	14,000
6	150	7.0	4	310	18,550	50.5	370	1,000	13,200	14,200
7	175	7.5	5	314	26,400	51.5	385	1,300	12,900	14,200
8	200	8.0	5	319	34,375	52.5	400	1,600	12,500	14,100
9	225	9.0	3	324	42,475	53.5	430	1,800	11,600	13,400

In the above table, the bending moments divided by the column distance gave the column stresses, and these divided by the areas gave the unit stresses from wind load.

The transverse bracing of the tower is proportioned to resist the shears tabulated above.

29. Calculation of Cable Wire.—The total length of each cable is given by Eq. (114):

$$L = l \left(1 + \frac{8}{3} n^2 \right) + 2l_1 \left(\sec \alpha_1 + \frac{8}{3} \frac{n_1^2}{\sec^3 \alpha_1} \right)$$

$$= 1,080(1.027) + 720(1.034 + 0.003) = 1,110 + 746 = 1,856 \text{ ft.}$$

To this must be added 43 ft. of cable at each end, between end of truss span and anchorage eyebars (scaled from drawing); hence,

$$\text{Total } L = 1,856 + 86 = 1,942 \text{ ft. per cable}$$

No. 6 galvanized cable wire will be used = 0.192 in. diameter = 0.029 sq. in. area. Each cable consists of seven strands of 386 wires each = 2,702 wires at 0.29 sq. in. = 78 sq. in. (as required).

Weight of No. 6 galvanized wire = 0.1 lb. per ft.

Total cable wire = $2 \times 2,702$ wires at 1,942 ft. = 10,500,000 lin. ft.

Total weight of cable wire = 10,500,000 ft. at 0.1 lb. = 1,050,000 lb.

30. Calculation of Cable Diameter.—The area of a strand will be 10 per cent greater than the aggregate section of the wires composing it. In this case the area of each strand will be

$$(110 \text{ per cent}) \left(\frac{78}{7} \right) = 12.3 \text{ sq. in.}$$

The corresponding diameter is 3.96 in. The cable diameter will be three strand diameters = 11.9 in. (Adding the thickness of wrapping, the finished cable will be 12.2 in. in diameter.)

31. Calculation of Wrapping Wire.—The wrapping consists of No. 9 galvanized wrapping wire (soft, annealed), weighing 0.06 lb. per ft. Deducting lengths of cable bands, etc., there will be 3,250 ft. of cable to be wrapped. Since the wrapping wire is 0.15-in. diameter, it will make 80 turns per lin. ft. The diameter of the cable is 11.9 in., hence the length of each turn will be 3.16 ft.

Length of wrapping wire = 80 turns at 3.16 ft. =
253 ft. per lin. ft. of cable.

Weight of wrapping wire = 253 ft. at 0.06 lb. =
15.2 lb. per lin. ft. of cable.

Total wrapping wire = 3,250 ft. of cable at 15.2 lb. = 50,000 lb.

32. Estimate of Rope Strand Cables.—Instead of building the cable of individual wires, manufactured rope strands may be used. In the case at hand, with a factor of safety of 3, there would be required 61 $1\frac{3}{4}$ -in. strands per cable.

Cable stress per strand = 4,700 kips \div 61 = 77 kips.

Allowable stress per $1\frac{3}{4}$ -in. strand = 248 kips \div 3 = 82 kips.

(Allowable stress per $1\frac{5}{8}$ -in. strand = 212 kips \div 3 = 70 kips.)

These galvanized steel ropes weigh 5.10 lb. per ft., hence, the total weight in the cables would be

$2 \times 1,942$ ft. \times 61 strands at 5.10 lb. = 1,210,000 lb. or 15 per cent heavier than the parallel wire cables.

The diameter of the resulting cable would be $7 \times 1\frac{3}{4}$ in. = 12.25 in. plus the wrapping.

(If rope strands are used, it should be remembered that their modulus of elasticity E is less than 20,000,000, as compared with about 30,000,000 for parallel wire cables.)

ERECTION OF SUSPENSION BRIDGES

The erection of suspension bridges is free from the hazards attending other types of long span construction.

The normal order of erection is: Substructure, towers and anchorages, foot bridges, cables, suspenders, stiffening truss and floor system, roadways, cable wrapping.

The cables are the only members requiring specialized knowledge for their erection. The other elements of the bridge, for the most part, are erected in accordance with the usual field methods for the corresponding elements of other structures.

33. Erection of the Towers.—The erection of the towers may proceed simultaneously with the construction of the anchorages.

For the Manhattan Tower of the Williamsburgh Bridge, a stationary derrick on the approach falsework was used to erect the steel up to roadway level; the erection was then completed by two stiff-leg derricks

mounted on a timber tower built up on the cross-girder between the two tower legs.

In the case of the Manhattan Bridge, the tower (Fig. 29) consists of four columns supported on cast steel pedestals resting on base plates set directly on the masonry pier. The tower columns were erected by the use of ingenious derrick platforms (one for each pair of columns) adapted to travel vertically up the tower as the erection proceeded. Each platform projected out from the face of the tower on the shore side and was supported by two bracket struts below. The tipping moment was resisted by sets of rollers or wheels engaging the edges of the columns, and the vertical support was furnished by hooks engaging the projecting gusset plates of the bracing system. With a 45-ft. stiff-leg derrick

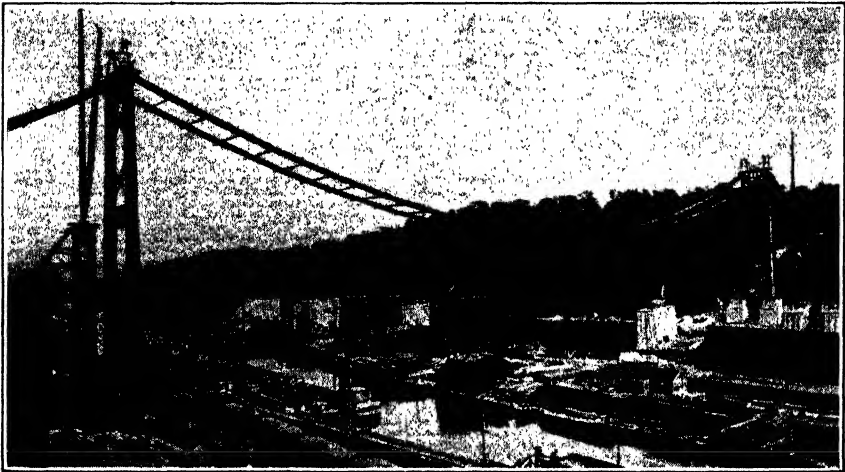

FIG. 28.—Kingston Bridge—Towers and footbridges. (1921—Span 705 ft.)

mounted on each platform, the sections of the tower were lifted from the top of the pier and set in place. When a full section had been added to the tower, blocks were fastened to the top and falls attached to the derrick platform by which it then lifted itself to the next level.

In addition to the two traveling derricks, there were required, for the erection of each tower: two hoisting engines and one stiff-leg derrick on the pier; two storage scows moored to the pier; a power plant with air compressor on shore; 30 pneumatic riveting hammers; and 6 forges. The force at each tower consisted of 100 men including 6 riveting gangs. The erection record was 2,000 tons of steel at one tower in 16 working days.

For smaller bridges, the towers may be erected by gin-pole or by stationary derrick alongside. For the suspension bridge at Kingston, N. Y. (Fig. 28), a guyed derrick with 95-ft. steel boom was set up on a

square timber tower 80 ft. high for the erection of each steel tower; the same derricks later erected the adjoining panels of the stiffening truss.

34. Stringing the Footbridge Cables.—The general method consists in taking one or more ropes across the river by means of a boat, and then raising to position.

For the Manhattan Bridge (Fig. 29), sixteen $1\frac{3}{4}$ -in. wire ropes were swung between the towers in four groups of four, each group to make a single footbridge cable. The four reels were mounted on a scow brought alongside one of the towers, *A*. The end of each rope was unreeled, hauled over a roller saddle on top of the tower, and secured to the anchorage *A*. Then the scow was towed across the river, laying the ropes along the bottom, to the opposite tower *B*. The remainder of each rope was

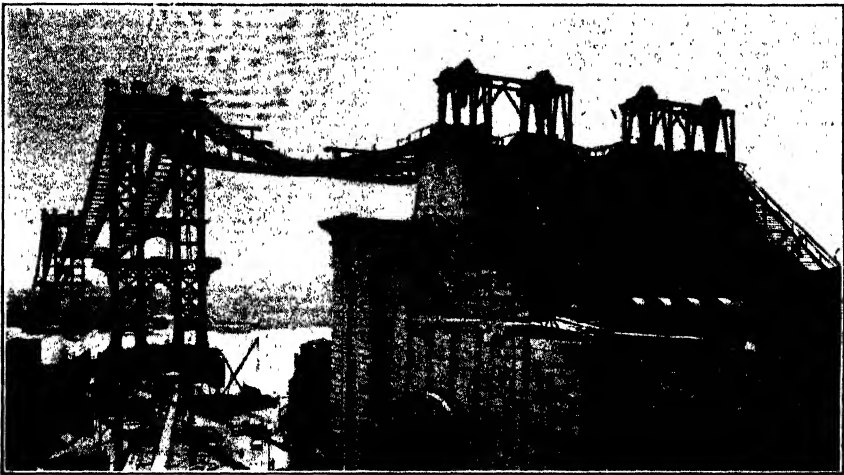

FIG. 29.—Manhattan Bridge—Cable spinning. (1909—Span 1,470 ft.)

then unreeled and coiled on the deck of the scow. Then, while river traffic was stopped for a few minutes, the free end of each rope was hauled up by a line over the top of tower *B* to the anchorage *B*, the middle of the rope or bight rising out of the water during this operation. The ropes were then socketed and adjusted to the precise deflection desired as determined by levels.

35. Erection of Footbridges.—The next step is the construction for each cable of a footbridge or working platform which permits the wires to be observed and regulated throughout their length, and greatly facilitates the entire work on the cables (Figs. 28, 29, 32).

For the Manhattan Bridge (Figs. 29, 32), four platforms were constructed, 8 ft. wide, placed concentric with the main cables and 30 in. (clear) below them. The timber floor beams were secured to the upper

side of the footbridge cables by U-bolt clamps. Upon the outer portions of the floorbeams were dapped the stringers, and on these were spiked the floorboards. Each platform carried "hauling towers" (Fig. 29), about 250 ft. apart, to support the sheaves of the hauling ropes used for placing the strand wires. The platforms were braced and guyed by backstays from each tower, and by inverted storm cables connected to them at 54-ft. intervals (Fig. 29); and were provided with wire rope hand rails.

For the Brooklyn Bridge, the timber staging consisted of one longitudinal footbridge and five transverse platforms, called "cradles," from which the wires were handled and regulated-during cable-spinning.

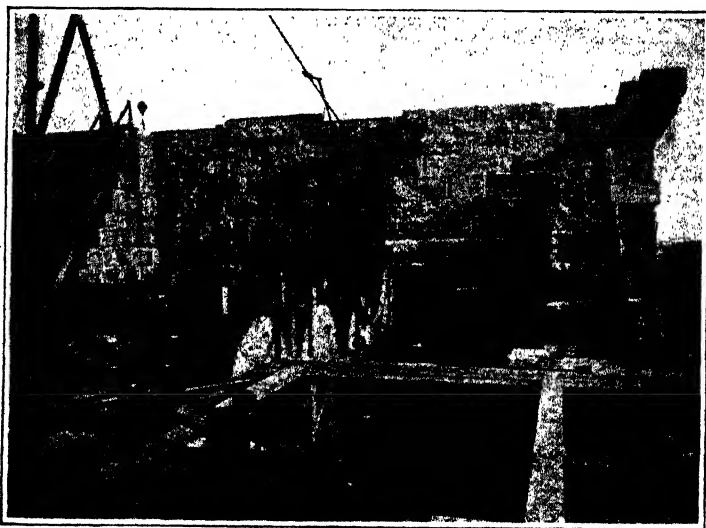

FIG. 30.—Williamsburgh Bridge—Traveling wheel for cable spinning. (1903—Span 1,600 ft.)

36. Initial Erection Adjustments.—It has become general practice to use the method introduced by Roebling of spinning the desired number of parallel wires in place and then combining them into a cable.

Guide wires are used as a means of adjusting the individual wires to equal length.

Special computations have to be made for the location of the guide wires, for setting the saddles on top of the towers, and for the length of the strand legs.

Knowing the desired final position of the cable under full dead load, its length is carefully computed from center to center of shoe pins at the anchorage. Applying corrections for elastic elongation (due to suspended load) and for difference of temperature from the assumed mean,

the length of unloaded cable is determined. This gives the length of the guide wire between the same points.

Assuming no slipping of the strands in the saddles, the initial position of the saddles is computed so as to balance tensions between the main and side span catenaries. This gives the distance the saddles must be set back (toward shore) from their final position on the tops of the towers.

Since the strands will be spun above their final position, the initial position of the strand shoes will be a short distance forward or back of their final position. This distance is carefully computed and gives the



FIG. 31.—Williamsburgh Bridge—Strand shoes in position during cable spinning. (1903—Span 1,600 ft.)

required length of the strand legs (Fig. 31). The distance may also be determined or checked by actual trial with the guide wire.

Taking into consideration the previously calculated and corrected total length of cable between strand shoes, the initial raised position of the strands above the tower saddles, and the length of strand legs shifting the initial position of the strand shoes, the ordinates of the initial catenaries in main and side spans are carefully computed. These ordinates are used for setting the guide wires with the aid of transit and level stationed at towers and anchorages.

The initial erection adjustments for the Brooklyn, Williamsburgh, Manhattan, and Kingston Bridges are summarized and compared in the following table:

INITIAL POSITION OF CABLE STRANDS
With Reference to Final Position

	Height above crown, feet	Height above saddle, feet	Distance saddle set back, feet	Distance shoe set back, feet
Brooklyn.....	57.0	2.1	0.1	+12.0
Williamsburgh.....	15.0	2.0	2.75	+ 3.0
Manhattan.....	2.0	2.0	0.0	- 1.83
Kingston.....	1.25	1.25	0.5	- 0.25

37. Spinning of Cables.—The operation of cable spinning requires an endless wire rope or “traveling rope” (Figs. 29, 30) suspended across the river and driven back and forth by machinery for the purpose of drawing the individual wires for the cable from one anchorage to the other. There is also suspended a “guide wire” which is established by computations and regulated by instrumental observations so as to give the desired deflection of the cable wires.

Large reels upon which the wires are wound are placed at the ends of the bridge alongside the anchor chains (Figs. 29, 30). The free end of a wire is fastened around a grooved casting of horseshoe shape called a “shoe” (Fig. 31), and the loop thus formed is hung around a light grooved wheel (Fig. 30) which is fastened to the traveling rope. The traveling rope with its attached wheel, moving toward the other end of the bridge, thus draws two wires simultaneously across from one anchorage to the other; one of these wires, having its end fixed to the shoe, is called the “standing wire”; while the other, having its end on the reel, is called the “running wire” and moves forward with twice the speed of the traveling rope. Arriving at the other end, the wire loop is taken off the wheel and laid around the shoe at that end. The two wires are then adjusted so as to be accurately parallel to the guide wire, the operation of adjustment being controlled by signals from men stationed along the footbridge. The wire is then temporarily secured around the shoe, and a new loop hung on the traveling wheel for its second trip. After 200 or more wires have thus been drawn across the river and accurately set, they are tied together at intervals to form a cable strand.

For the Manhattan Bridge, the wires (drawn in 3,000-ft. lengths) were spliced to make a continuous length of 80,000 ft. (4 tons) wound on a wooden reel. On each anchorage were set eight reel stands, each with a capacity of four reels (Fig. 29). Supported above the footbridges were eight endless $\frac{3}{4}$ -in. steel “traveling ropes” passing around 6-ft. horizontal

sheaves at the anchorages. Attached to each endless rope at two equidistant points were deeply grooved 4-ft. carrier sheaves ("traveling wheels") in goose-neck frames (Figs. 29, 30). The "strand shoe" (Fig. 29) was held 22 in. in front of final position by a special steel construction called a "strand leg" attached to the pin between two anchorage eyebars. (In the case of the Williamsburgh Bridge, Fig. 31, the strand-leg construction was reversed, the shoe being held 3 ft. *back* of final position.) The bights of wire were placed around the traveling wheels and pulled across, taking about 7 min. for a trip of 3,223 ft. from anchorage to anchorage. As each part of the wire became dead, it was taken by an automatic Buffalo grip and adjusted to the guide wire. After each strand (256 wires) was completed, the wires were compacted with curved-jaw tongs and seized with a few turns of wire every 10 ft. Then, with a "strand bridle" attached to a 35-ton hydraulic jack, the shoe was pulled toward shore, releasing the strand leg and the eyebar pin. The strand shoe was then revolved 90 deg. to a vertical position and pulled back to position on the eyebar pin. The strand was then lifted from the temporary sheaves in which it was laid at the anchorages and the towers, and lowered into the permanent saddles; a 20-ton chain hoist and steel "balance beam" being used for this operation. The strand was then adjusted to the exact position desired by means of shims in the strand shoe. After the seven center strands of a cable were completed, they were bunched together with powerful hydraulic squeezers to make a cylinder about $9\frac{1}{4}$ in. in diameter. Then the remaining strands were completed and compacted in two successive layers around the core. Then the cable was coated with red lead paste, and the permanent cable bands and suspenders were attached. The foot bridges were hung to the completed cables to be later used for the work of cable wrapping, and the temporary foot bridge cables were cut up for use as suspenders.

38. Erection of Trusses and Floor System.—The suspension from the cables permits the steelwork to be erected without falsework.

In the Manhattan Bridge, the truss is supported at each panel point by four parts of $1\frac{3}{4}$ -in. steel rope suspenders with their bights engaging the main cables and having at the lower end nut bearings on horizontal plates across the bottom flanges of the lower chord.

All members were shipped separately, the chord members in two-panel-length pieces weighing 26,000 to 30,000 lb. each.

The erection proceeded at four points simultaneously, working in both directions from each tower (Fig. 32). Traveler derricks of 25-ton capacity were used, with 34-ft. mast and 50-ft. boom, provided with bull-wheel. At each point of erection there were two of these large derricks, also one jennywink derrick with 30-ft. boom and 7-ton capacity. In addition to these twelve movable derricks, there were four stationary steel-boom derricks at the towers.

Starting at the towers, the lower chords and floor system were assembled two panels in advance of the travelers, making temporary connections to the suspenders (Fig. 32), until the anchorages and mid-span were reached. Then the travelers returned to the towers to commence their second trip.

The material was hoisted by the tower derricks and loaded on service cars which delivered it to the traveler derricks.

On the first trip, the lower chords, lower deck and verticals were erected; on the second trip, the truss diagonals were erected; and on the return (Fig. 33), the upper deck and transverse bracing were put up, thus completing the structure.

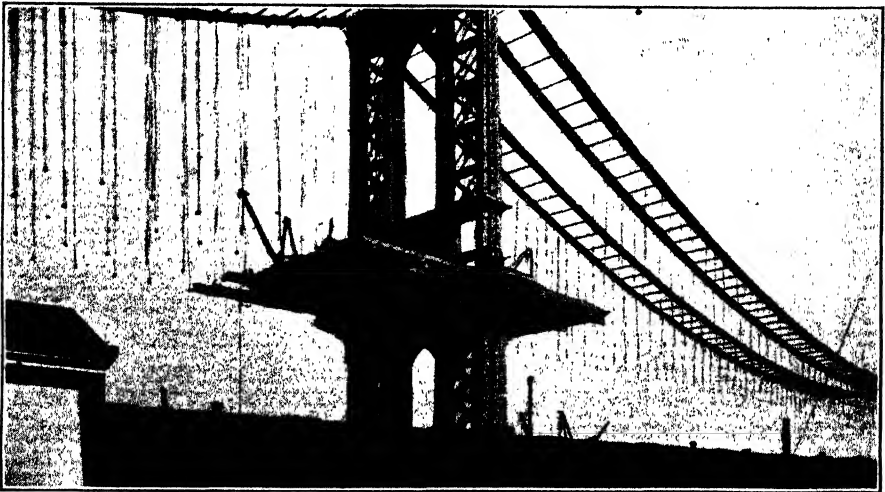

FIG. 32.—Manhattan Bridge—Erection of lower chords and floor system. (1909—Span 1,470 ft.)

A force of 300 men was employed on this work, and their record was 300 tons of steel erected in a day.

The first few panels of the main span are generally erected by the stationary derricks at the tower as far as their booms can reach. Additional panels may be erected by drifting or outhauling from the cable; or by the use of "runners," that is, block and falls suspended from the advance cable band and operated by the hoisting engine at the tower. At Kingston, the latter method was adopted, dispensing with the use of travelers.

39. Final Erection Adjustments.—The elevations and camber of the roadway are checked with levels and corrected where necessary by adjusting the lengths of the suspenders.

In completing the stiffening truss, the closing chord members should be inserted after all the dead load is on the structure, the connecting holes at one end being drilled in the field.

If the closure of the stiffening truss has to be made before full dead load is on the structure or at other than mean temperature, the vertical deflections are computed for these variations from assumed normal conditions and the suspenders adjusted accordingly before connecting the closing members. In adjusting the suspenders, the center hanger is shortened or lengthened the calculated amount, and the other hangers are corrected by amounts varying as the ordinates to a parabola.

If the trusses are assembled on the ground before erection, the exact camber ordinates can be measured and reproduced (by suspender adjustment) so as to secure zero stress under full dead load at mean temperature.

An ideal method of checking the final adjustments is by means of an extensometer, which should check zero stresses throughout the stiffening

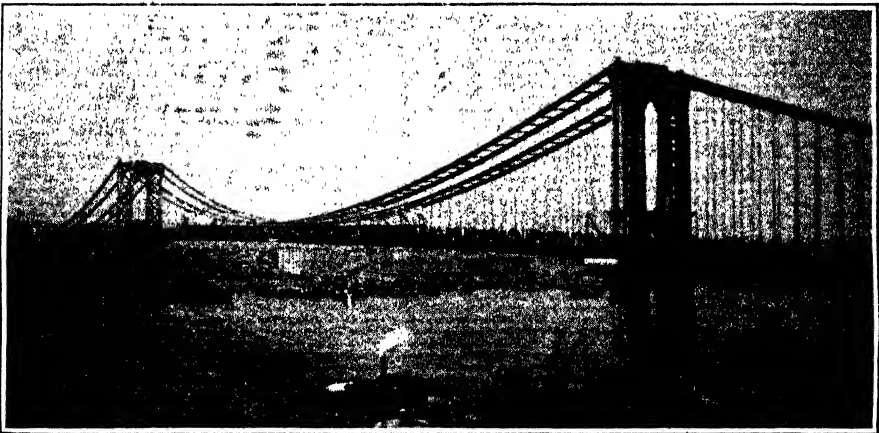

FIG. 33.—Manhattan Bridge—Erection of upper chords of stiffening truss. (1909—Span 1,476 ft.)

truss when normal conditions are attained, or calculated stresses for any variation from assumed normal conditions.

40. Cable Wrapping.—Close wire wrapping has proved to be the most effective protection for cables.

For the Manhattan Bridge, No. 9 galvanized soft steel wire (0.148 in. in diameter) was used. This was rapidly wound around the cable by a simple and ingenious machine operated by an electric motor. This machine, designed by H. D. Robinson, is illustrated in Fig. 34.

In advance of the machine, the temporary seizings are removed and the cable painted with a stiff coat of red lead paste. The end of the wrapping wire is fastened in a groove at the end of the cable band. The machine, carrying the wire on two bobbins or spools, travels around the cable and applies the wire under a constant tension. The machine presses the wire against the preceding coil and at the same time pushes itself along at a rate of about 18 ft. per hr.

The machine weighs 1,000 lb. and is operated by a $1\frac{1}{2}$ -h.p. motor at a speed of 13 rev. per min. It is handled by a force of six men.

41. Erection of Wire Rope Cables.—The individual wire ropes composing a cable of this type may be towed across the river in the same manner as the temporary footbridge ropes of a parallel wire cable (see p. 349); or they may be strung across by means of a single working cable stretched from tower to tower.

The latter method was used for a footbridge of 540-ft. span built over the Cumberland River by the American Bridge Company (Fig. 25). Each cable consisted of seven ropes of $1\frac{7}{8}$ in. in diameter. A working cable of 1-in. wire rope was first stretched across between the towers for each of the main cables. The main ropes were unwound from the reels back of one

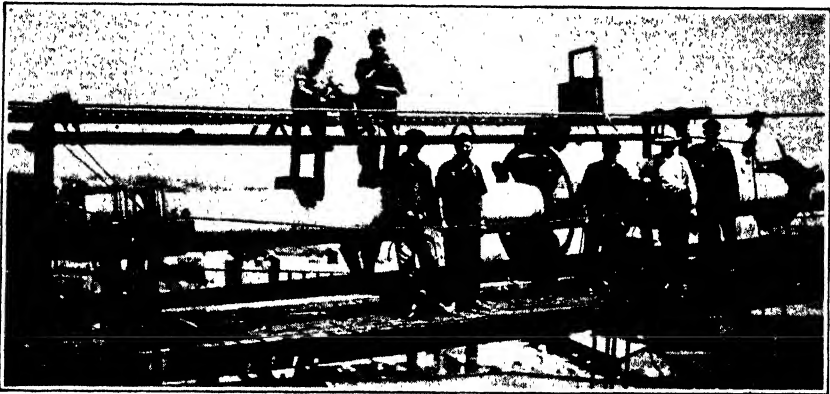

FIG. 34.—Cable wrapping machine in working position on Manhattan Bridge.

tower. One end of a rope was lifted to the top of the tower and hauled across the river to the top of the opposite tower, the rope being supported from the 1-in. working cable by blocks attached at intervals of about 60 ft., thus preventing too much sag. The rope was then lowered to approximately correct position, and the sockets attached to the tower shoes. The remaining ropes were then stretched in the same manner, and all were then adjusted by nuts at the ends until they touched a level straight edge held on the fixed line of sag determined by a transit in the tower. The cable clamps and suspenders were then placed by men on a movable working platform hung from the cables, beginning in the center and working toward each end. The floor system was also erected by men on the working platform, in this case working from both ends toward the center. The platform was then removed, and the trusses were erected from the ends toward the center by workmen on the floor system, using the two working cables (shifted to the center of the bridge) as a trolley cable for

transporting the truss sections to position. Adding the top lateral bracing, railings, and wood floor, the structure was completed.

42. Erection of Eyebar Chain Bridges.—Chain suspension bridges have, as a rule, been erected upon falsework.

For the Elizabeth Bridge at Budapest (1902, span 951 ft.), the falsework consisted of huge scaffoldings built on piles and protected from floating ice by ice breakers. Four openings of 160 ft. were left for vessels, and these openings were spanned by temporary timber bridges floated into place on pontoons. After the falsework was completed, the main chains were erected in 12 weeks. The falsework was then taken down and the steelwork completed.

A different scheme, eliminating heavy falsework, was used for the Clifton Bridge (1864, span 702 ft.). Under each set of three chains, a suspension foot bridge was constructed, using wire ropes. Above this staging, another rope was suspended to carry the trolley frames for transporting the links. The chains were commenced simultaneously at the two anchor plates; the lowest of the three chains being laid first. Commencing at the anchorage, there were inserted the whole of the links, namely 12, then 11, 10, 9, 8 and so on until the chain was diminished to one link; then the chain was continued with one and two links, alternately, until the two-halves met at mid-span. The suspended foot bridge was strong enough to carry the weight of this chain until the center connection was made; the chain was then made to take its own weight by removing the blocking under it. The next operation was to add the remaining links of the chain on the pins already in place. The process was repeated for the upper chains, and then the roadway was suspended.

43. Time Required for Erection.—The time schedule for the Manhattan Bridge (1,470-ft. span) was as follows:

First substructure contracts let.....	1901
Pier foundations commenced.....	May, 1901
Work commenced on final (revised) design.....	March, 1904
Steel towers commenced.....	July, 1907
Towers completed (12,500 tons).....	July, 1908
Temporary cables strung.....	June 15-20, 1908
Foot bridges constructed.....	July 7-13, 1908
Spinning of main cables commenced (4 cables).....	Aug. 10, 1908
Last wire strung (37,888 wires).....	Dec. 10, 1908
Erection of suspended steel commenced.....	Feb. 23, 1909
Suspended steel completed (24,000 tons).....	June 1, 1909
Approaches completed and bridge formally opened...	Dec. 31, 1909

The steel erection, amounting to 42,000 tons of steel between anchorages and including towers, cables, trusses and decks, was accomplished in two and one-half years.

The Kingston Suspension Bridge (705-ft. span) was completed in one year (1920-1921), although several months were lost waiting for steel delivery. The bridge contains 1,600 tons of structural steel and 250 tons of cables.

The 400-ft. span suspension bridge at Massena, N. Y., containing 400 tons of steel, was erected complete in six months.

44. Suspension Bridges, 1923-1943.—As the methods of design outlined in the previous articles are still valid, attention will be focused on the improvements in design and erection details. Many of these improvements have been brought about by the construction of heavy and extremely long spans. In the following articles, therefore, consideration will be given principally to erection features.

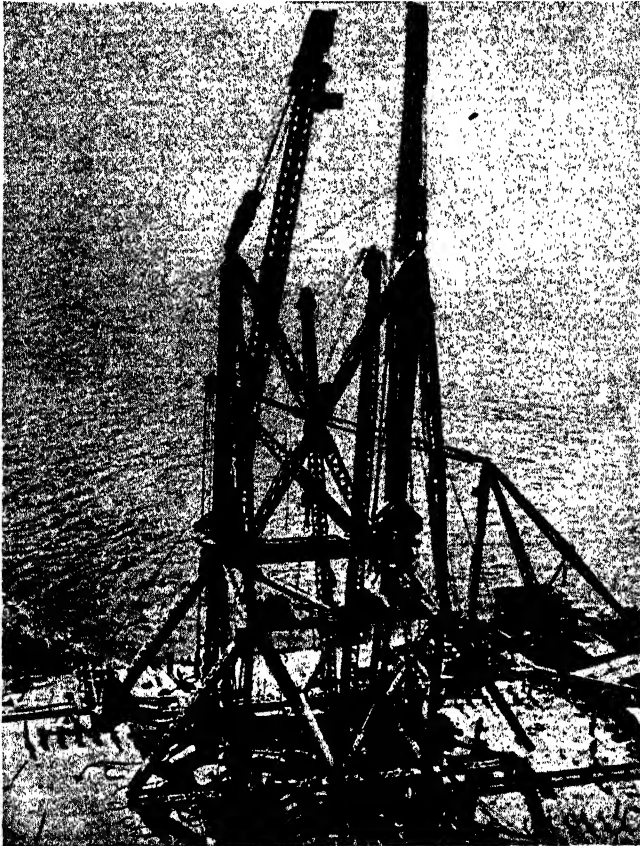

FIG. 35.—Erection traveler Golden Gate Bridge. (Courtesy of the Bethlehem Steel Co.)

45. Erection of Towers.—The erection of the towers of the George Washington and Golden Gate Bridges was made by means of a traveler, consisting of two stiff-leg derricks mounted on a steel framework between

the tower columns (Fig. 35). As the traveler moved up the tower in stages limited to the reach of the derrick booms, each derrick erected one column and a part of the cross bracing connecting the columns.

The bottom sections of the tower columns of the suspension spans of the San Francisco Bay Bridge were erected by a stiff-leg derrick, which was placed on the masonry piers between the tower columns.

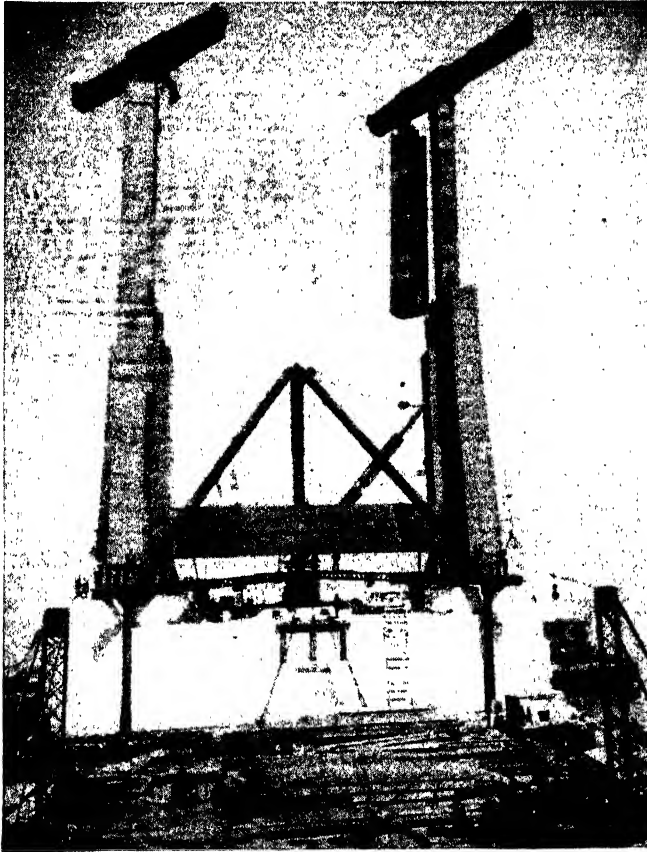

FIG. 36.—Hammerhead cranes, San Francisco Bay Bridge. (Courtesy of the American Bridge Co.)

The derrick was also used to erect two hammerhead cranes and to lift the remaining tower sections and cross bracing from the barges to the pier top within reach of the cranes. One hammerhead crane was placed in the inner well of each tower column (see Fig. 36). The main mast of each crane consisted of a box girder type column, 5 ft. square in cross-section and 108 ft. long. The lower end was tapered to permit keeping the mast plumb as the inner well of the tower column is slightly inclined. Within the upper end of the main mast there was mounted another

column 3.5 ft. square and 24.5 ft. long. To the upper end of this column a cross-arm was rigidly attached. This unit was so designed that it could be rotated about its vertical axis. A traveling car with the upper block of the lifting falls attached to it was mounted on a track on the forward side of the cross-arm. A concrete counterweight was attached to the other side, in such a manner as to permit it to be lowered to the masonry pier when not required. It was necessary to use the counterweight only when the car with load was more than 10 ft. from the mast to keep the bending moment in the mast within the design limits. As it was always possible to keep the car, when loaded, within 10 ft. or less of the mast whenever it was necessary to rotate the hammerhead, the counterweight was lowered to the pier during this operation. After each 50-ft. section of a tower column was erected, the cranes were raised and the process repeated until the erection of the columns together with their cross bracing was completed. The cranes were then used to raise the saddles and erect a guy derrick on the tower top. This derrick was used to dismantle the cranes, place diaphragms in the central wells, place the cap plates, and aid in subsequent operations.

46. Stringing Footbridge Cables.—On the San Francisco Bay Bridge the footbridge cables were kept in sufficient tension, when being hauled from one tower to the other, so that they were always clear of the water. This was very desirable, as the water of the bay is salt and its bottom is covered with a mud that has very penetrating finely divided particles. Furthermore these cables were cut up and used as suspenders in the finished bridge after the main cables had been erected and the footbridges attached to them with wire rope slings. Before shipment the footbridge cables were prestressed which reduced their mechanical stretch, furnished data necessary for calculating their modulus of elasticity, and also permitted the accurate control of the sags in the footbridges.

On the Golden Gate Bridge, contrary to usual practice, the footbridge cables were not intended for use as suspenders in the finished bridge. Several advantages are secured by this arrangement. The use of material which is to be used in the finished bridge is not required for a temporary service in which it might be damaged. Cables satisfactory for supporting the footbridge only, weighed 5 lb. per ft. whereas the suspender cables weighed 12.5 lb. per ft. Not only were the lighter cables easier to erect, but after they were in place, it was not necessary to disturb them until they were no longer needed. This method reduces the field operations and permits complete fabrication of the suspenders at the shop before shipment.

47. Erection of Footbridges.—The footbridges of the Golden Gate Bridge differed in several respects from those usually employed. Instead of wooden stringers the cables were used for these members. This was done by spreading out 12 lines for one footbridge and 13 for the other.

This reduced the weight and saved some time in erection. The conventional bents or towers that carry the cable spinning tramways and are erected on the footbridges were not used on this bridge. Instead, the sheaves carrying the tramway cables were attached to cables suspended from the main bridge towers. These cables were also tied into the storm-bracing system of the footbridges. This scheme reduces weight, provides cushioning to the impact of the spinning carriages on the supporting sheaves, and adds stability to the footbridges and storm system.

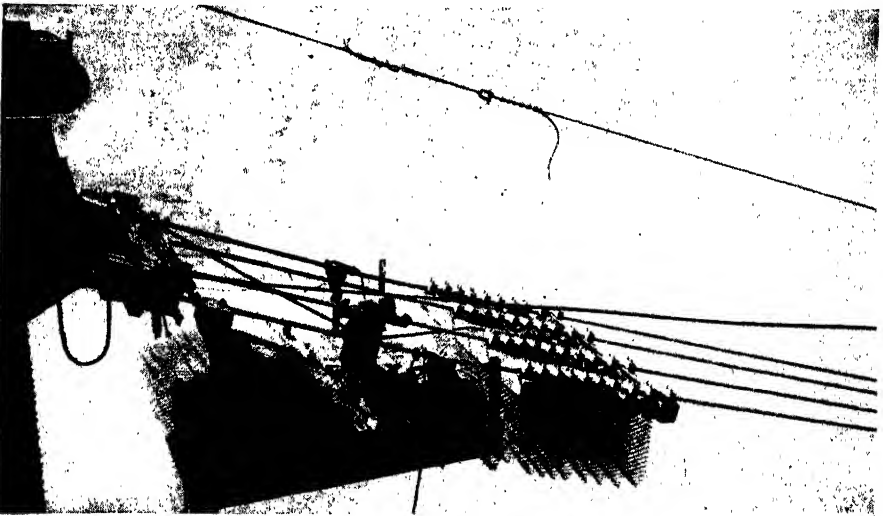

FIG. 37.—Footbridge erection, San Francisco Bay Bridge. (Courtesy of the American Bridge Co.)

The footbridges for the San Francisco Bay Bridge were also unusual in several respects. Their floor system consisted of wood floor beams to which three strips of chain link fencing were stapled, giving a width of 10 ft. The floor was fabricated on shore in units 100 ft. long. After the units were fabricated, they were telescoped into compact bundles and shipped to the piers by barge. At that point they were hoisted one at a time to the tower tops. They were then attached to the four footbridge cables, spliced together, and allowed to slide down the cables (Fig. 37). After all the units had been placed, the mesh was stretched until it formed a flat walk. The fencing had a 2-in. mesh which was somewhat too coarse for a footwalk surface. It was covered with a wire hardware cloth of finer mesh that gave good footing and prevented the loss of tools and other small objects. Some of the advantages of this type of footbridge are reduced fire hazard, less weight, less exposed area to wind action, and greater ease of fabrication, erection, and dismantling.

48. Initial Erection Adjustments.—The initial adjustments outlined in Art. 36 have been the usual practice on suspension bridges having parallel wire cables. On the San Francisco Bay Bridge, however, the strands were spun in place in the tower saddles and strand shoes with the exception of three strands in each cable which had to be moved a short distance. This method eliminated the use of balance beams at the towers and also the moving and placing of the strand shoes over the pins in the anchorage eyebars after each strand was completed.

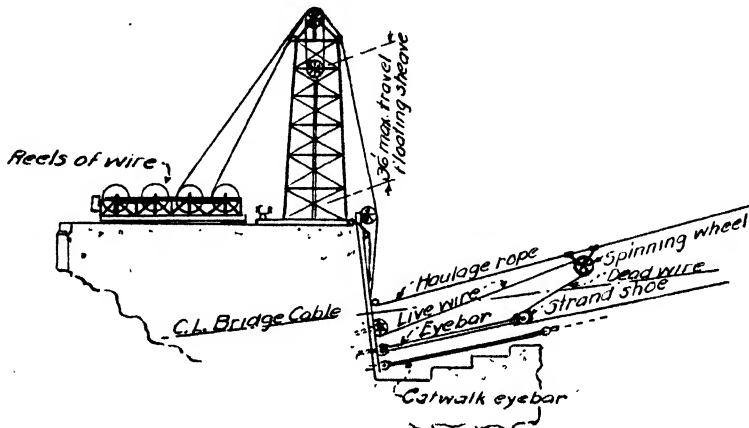

FIG. 38.—Compensation tower and spinning equipment, San Francisco Bay Bridge. (Courtesy of Engineering News-Record.)

49. Spinning of Cables.—Although the basic methods of spinning parallel wire cables have not changed, there has been a definite improvement in the art during the last twenty years. This has been due to the desire to produce better cables and to reduce the time required for spinning the wire.

Prior to the construction of the George Washington Bridge, the reels on which the wire was mounted for spinning were controlled by brakes only. The rotation of the reels was started and maintained by the pull of the spinning carriages. Any variation of the carriage speed caused the "live" or "running" wire to whip and surge about. This action is very marked when the reels are full of wire and slows up the spinning time materially. This undesirable action was virtually eliminated on the George Washington Bridge by the use of power-driven reels and compensation towers. The compensation tower contained several sheaves, one of which was floating and acted as a counterweight. The wire from the reels was reeved through the several sheaves before passing around the spinning wheels, and the dead ends made fast.

The floating sheave tends to hold the wire under uniform tension. The operator of the motor driving the reels varied their circumferential

speed so that it conformed closely to that of the spinning carriages. This was done by keeping the floating sheave as near one position as possible during the movement of the spinning carriages. Similar methods were used on both the Golden Gate and San Francisco Bay Bridges (Fig. 38).

Improvements in carriage design with more positive control of the reels and tension in the wire have permitted the spinning to be increased approximately 70 per cent, or in excess of 600 ft. per min. On the Golden

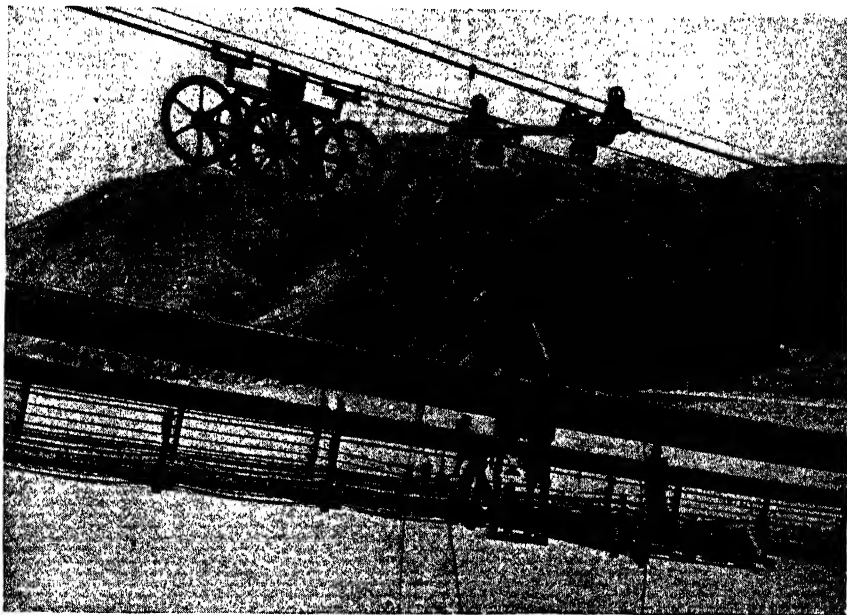

FIG. 39.—Spinning carriage, Golden Gate Bridge. (Courtesy of the Bethlehem Steel Co.)

Gate Bridge the speed of placing the wire was further increased by the use of a two-wheel carriage. This type of carriage had been previously tried with success on the last strands of the George Washington Bridge. Before the spinning operations on the Golden Gate Bridge were completed, a third wheel was added to the carriage (Fig. 39). The tramways that supported these carriages were also unusual in that they did not extend from anchorage to anchorage. They were so designed that a carriage passed from an anchorage to a transfer station at the center of the main span. At this point the wires from each carriage were transferred to the other, so that when the carriages returned to the anchorages, each set of wires had been hauled from one anchorage to the other. As a split tramway was used on both sides of each main cable, a total of 24 wires was placed for each complete cycle of the three-wheel carriages and 16 wires for the two-wheel carriages. Because of the large number of

wires to be adjusted at one time, it was necessary to adopt some means of distinguishing the wires. Therefore, the wire from one of the two reels feeding a carriage was sprayed with a distinctive color. Both the color and the original placing of the wires in their proper guides at the control points enabled the adjusters to keep the wires identified.



FIG. 40.—Strand shoes and spinning carriage, San Francisco Bay Bridge. (Courtesy of the American Bridge Co.)

On the San Francisco Bay Bridge the carriages were equipped with a single spinning wheel that had two grooves, each of which carried four parts of wire. The tramways extended as usual from anchorage to anchorage. The two main cables of each suspension section were spun at the same time. After the cables in one section were completed, the spinning equipment was dismantled and reerected and the cables in the other section spun. A carriage was mounted on the tramway at each anchorage so that a total of eight wires was placed by each passage of

the carriages from one anchorage to the other. The strand shoes were placed in pairs on each side of a group of anchorage eyebars (Fig. 40). The tower saddles were stepped, instead of grooved, with the strands of square cross-section at this point (Fig. 41). This design eliminated the use of fillers between strands and gave a very compact section at the saddles. All these details permitted the spinning of the wire in place, which materially speeded up the cable construction.

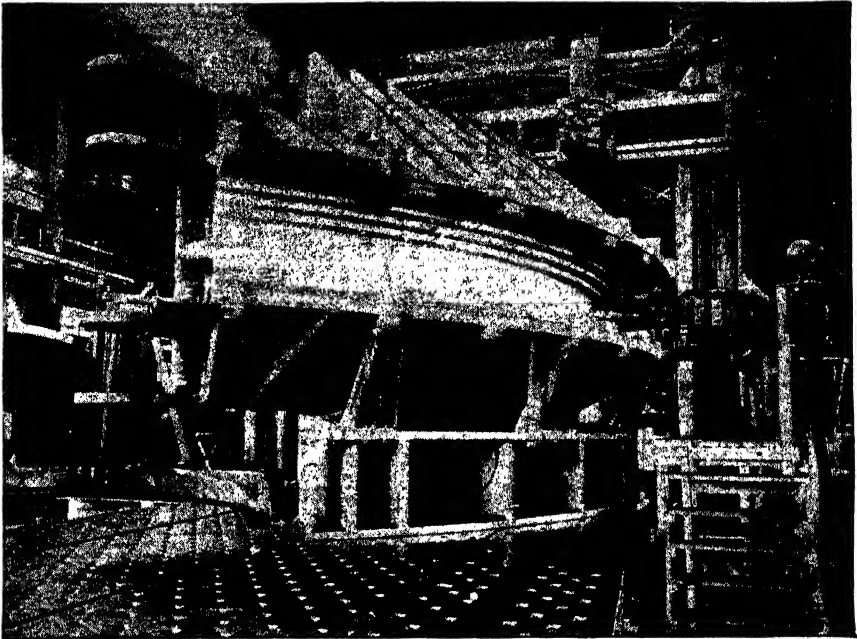

FIG. 41.—Tower saddle, San Francisco Bay Bridge. (Courtesy of the American Bridge Co.)

It was found advisable on the George Washington Bridge to use power in adjusting the wires, as a force of about 600 lb. was necessary to pull a wire into its proper position. To accomplish this, several endless power-driven cables were mounted along the footwalks. The "come along" grips were attached to one end of a pennant line, the other end of which was attached to the power-driven cable. The cable drive was reversible and could be controlled by the man operating the "come along," or the adjuster. This device used in conjunction with a signal system of lights has proved satisfactory on long suspension spans.

The cross-section of a parallel wire cable tends to assume an elliptical form, with the longer axis normal to a vertical plane through the cable axis. The most desirable form of cross-section for the cable is circular. A very close approximation to this form was secured on both the Golden Gate and San Francisco Bay Bridges by two quite different methods.

On the Golden Gate Bridge the strands were laid up in vertical tiers rather than in the customary horizontal layers. The number of wires in the different strands was varied depending on the position of the strand in the cable. Before compaction the cross-section of the cable was hexagonal, with straight sides, placing the outside top and bottom strands in planes at 30 deg. with the horizontal, which tended to increase their stability. Previous practice placed the strands in horizontal layers, producing a hexagonal cross-section before compaction but with the outside strands at the top and bottom lying in the sides of the hexagon (Fig. 42). The new design produced a cross-section very close to the circular form after completion, with considerably less force required for compaction. On the San Francisco Bay Bridge the circular form was secured by the use of a

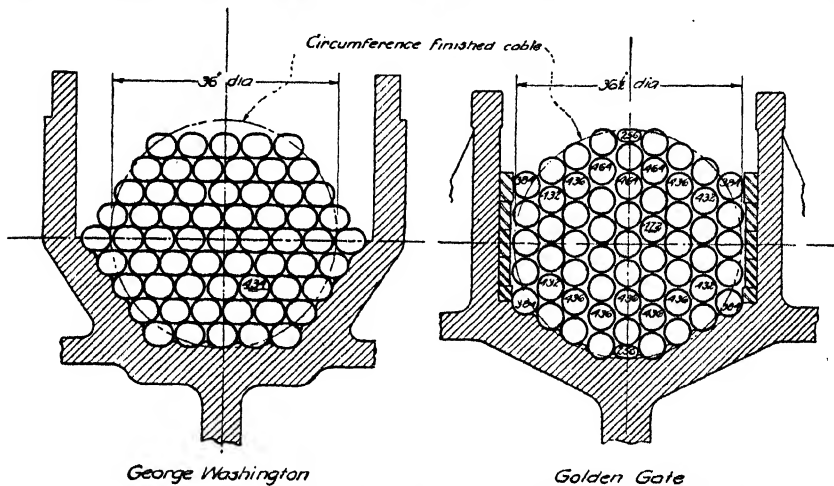

FIG. 42.—Cross sections of cables at tower saddles. (Courtesy of *Engineering News-Record*.)

new type of compacting machine. The usual type of compacting machine is equipped with hydraulic jacks mounted on a steel frame in such a manner that the jacks advance toward a common center. These jacks may be connected so that they act either simultaneously or in groups as desired. Their movement is dependent on the pressure applied to them and to the resistance they encounter. Unless particular care is taken in the design of the cable before compaction, as was done on the Golden Gate Bridge, it is virtually impossible to produce a compacted circular cross-section. To eliminate this action, the engineers on the San Francisco Bay Bridge designed a compacting machine equipped with chain-driven screw jacks. Each screw jack advances an equal amount, as its movement is dependent on the mechanical drive, which is independent of the resistance encountered.

The advance in the art of cable spinning is measured in part by the daily tonnage of wire placed. On the Manhattan Bridge (1908-1909)

the wires were placed at an average daily rate of 33 tons per cable. The wires in the Delaware River Bridge cables (1924-1925) were placed at about the same rate. On the George Washington Bridge (1929-1930)

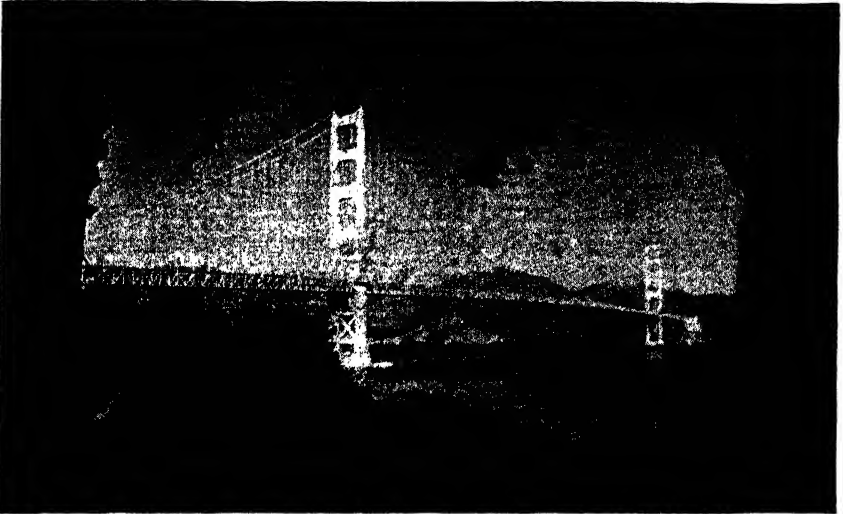

FIG. 43.—Golden Gate Bridge, San Francisco. (*Courtesy of American Institute of Steel Construction.*)

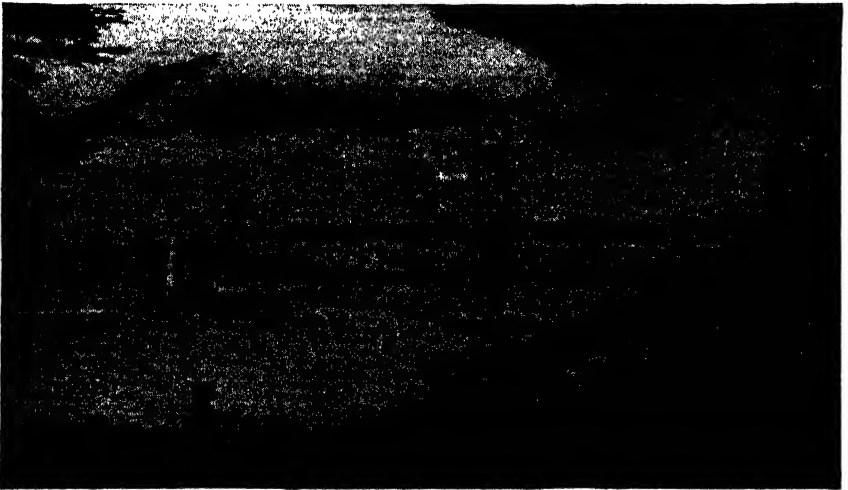

FIG. 44.—Suspension spans, San Francisco-Oakland Bay Bridge. (*Courtesy of American Institute of Steel Construction.*)

the rate was increased to 61 tons and on the East suspension span of the San Francisco Bay Bridge (1935-1936) to 64 tons. The average rate on the Golden Gate Bridge (1936) was approximately 173 tons per day.

50. Erection of Trusses and Floor System.—The trusses and floor system of the San Francisco Bay Bridge were assembled in units at a storage yard. The units consisted in general of two panels of trusses, two floor beams with intervening panel of lateral bracing, and one or two upper floor beams. These units were loaded on a barge and towed to the proper position beneath the bridge. The units were lifted into place by means of four sets of falls. The lower block on each set of falls was attached to the units near the upper end of the truss verticals. The upper blocks were attached to the main bridge cables by wire rope slings.

Floating towers have also been used to erect the trusses and floor system on some suspension bridges.

51. Some Features of the World's Largest Suspension Bridges.—A comparison of the span lengths and tower heights of some of the largest suspension bridges is interesting. They are shown in the accompanying tabulation:

Bridge	Year completed	Clear span (ft.)	Height of tower above water (ft.)
Golden Gate.....	1937	4,200	746
George Washington.....	1932	3,200	595
San Francisco-Oakland Bay.....	1936	2,310	515
Ambassador.....	1929	1,850	378
Delaware River.....	1926	1,750	375
Bear Mountain.....	1924	1,632	350
Williamsburgh.....	1903	1,600	333
Brooklyn.....	1883	1,596	273

The Golden Gate Bridge has the distinction of having the longest span of any bridge in the world (Fig. 43). The West Bay structure of the San Francisco-Oakland Bay Bridge is a twin suspension bridge with an anchorage at each end and a common anchorage at the center (Fig. 44).

SECTION 7

STEEL ARCH BRIDGES—GENERAL

1. **Classification and Types of Steel Arch Bridges.**—The steel arch structure is distinguished from the truss or girder in that the reactions at the supports are *inclined* rather than *vertical*. Figure 1a illustrates a typical steel truss structure. One support is derived from the fixed pin at *b* and the other from a pin resting at *a* on a roller nest, or other

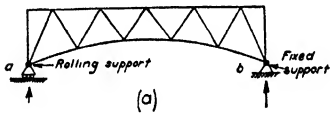

(a)

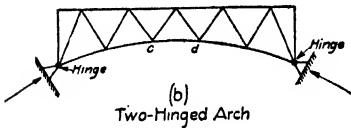

(b)
Two-Hinged Arch

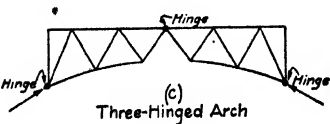

(c)
Three-Hinged Arch

FIG. 1.



FIG. 2.—Fixed arch



FIG. 3.—Single-hinged arch.

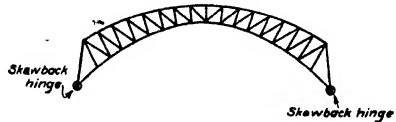

FIG. 4.—Two-hinged arch.

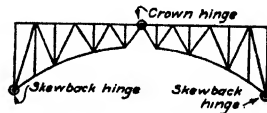

FIG. 5.—Three-hinged arch.

type of support so arranged as to provide for free lateral movement. From the figure, it is at once observed that both abutment reactions will be vertical in direction. If the roller at *a* be replaced by a fixed pin, as shown in Fig. 1b, the structure at once becomes a two-hinged arch. If member *c-d* were to be removed, the structure would become a three-hinged arch (see Fig. 1c).

Classified according to the method in which the stresses are distributed throughout the superstructure, arches may be grouped under four main headings as follows:

- (1) Hingeless or fixed arches as shown in Fig. 2.
- (2) Single-hinged arches as shown in Fig. 3.
- (3) Two-hinged arches as shown in Fig. 4.
- (4) Three-hinged arches as shown in Fig. 5.

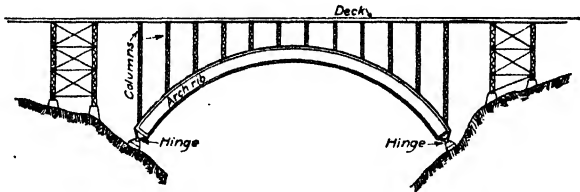

FIG. 6.—Parallel curve rib arch (deck span).

Classified in accordance with the method in which the rib is fabricated and the deck carried by the rib, arch bridges may be grouped under the following headings:

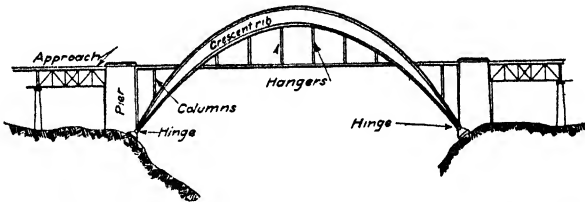

FIG. 7.—Half through arch, two-hinged crescent type (rib arch).

(1) *Solid Rib Arches*.—Arches of this character may be either fixed or with one, two or three hinges. The two-hinged type may be either *parallel curved* as shown in Fig. 6, or of the *crescent* type as shown in Fig.

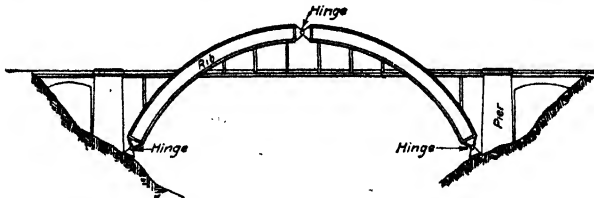

FIG. 8.—Parallel curve three-hinged arch rib.

7. The three-hinged type may be either *parallel curved* as shown in Fig. 8, or *lenticular* in section as shown in Fig. 9. The most commonly used form of "plate girder" or solid webbed arch rib is that of a *parallel curved* rib of constant depth throughout its length.

(2) *Braced Rib Arches*.—This type differs from the above type in that the solid web of the former is replaced by a system of diagonal bracing. Either a single or a double intersection web system may be used, as shown

in Fig. 10. The single intersection type avoids considerable ambiguity in analysis. The double type on the other hand is said to result in lower secondary stresses.

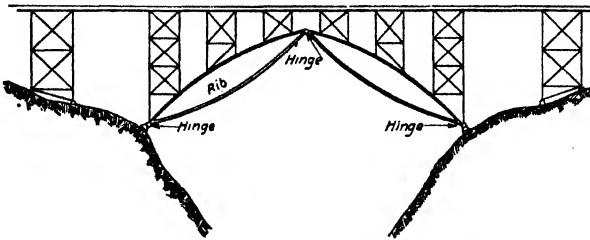
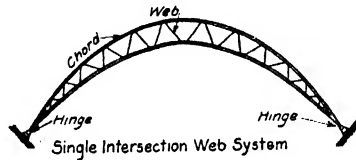
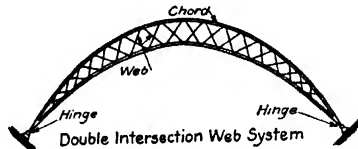

FIG. 9.—Lenticular rib arch (three-hinged).

(3) *Spandrel Braced Arches*.—Arches of this type are generally constructed with two or three hinges on account of the difficulty encountered



Single Intersection Web System



Double Intersection Web System

FIG. 10.—Braced rib crescent type two-hinged arch.

adequately anchoring the skewbacks to produce a condition of fixity at the abutments. This type of construction generally consists of

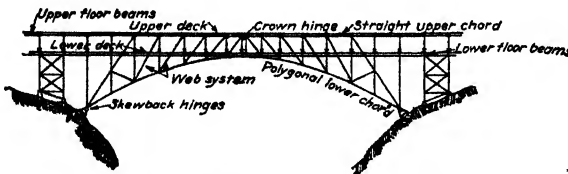

FIG. 11.—Double deck spandrel braced arch.

horizontal top chord, a curved or arched bottom chord, and a system of diagonal bracing connecting the two. Figure 5 illustrates this type of arch structure.

Arches may be further classified as through arches, half through-arches or deck arches in accordance with the method by which the roadway is supported by the arch proper. Through and half-through arches are nearly always of the rib type; although it is possible to construct a double deck spandrel-braced arch wherein the lower deck passes through the arch frames as shown in Fig. 11.

2. Relative Merits of Various Types of Arch Construction.

2a. Fixed or Hingeless Type.—The principal advantage claimed for this type of construction is its rigidity. Its principal disadvantage lies in the fact that a lateral yielding of the foundations will induce very heavy stresses in the superstructure. Other conditions being equal, this type will probably show a slight saving in metal over either of the hinged types of construction. One of the disadvantages charged against this type of construction is the labor involved in making the calculations. This, however, should not be considered a serious objection for fixed arch analysis has now been standardized to a point where the labor involved is not so great as formerly, and, moreover, the expense of even the most laborious calculation is very small in comparison with what may be saved on a large superstructure by refinements in design.

2b. Single Hinge Type.—This type of construction is very rarely used and possesses no distinct advantages. One of the most notable designs of this type was one proposed by Chas. Worthington for spanning the St. Lawrence River at Quebec, this design contemplating a structure of some 1,800-ft. clear span. This type of structure is undoubtedly less rigid than the fixed type and possesses only one distinct advantage, namely, that of definitely locating the line of thrust at the crown.¹

2c. Two-hinged Type.—Undoubtedly not as rigid as the fixed type, but involves somewhat less labor in the making of calculations. This type presents the advantage of definitely locating the thrust line at both skewbacks, which is a distinct advantage for certain foundation conditions.

2d. Three-hinged Type.—The principal disadvantage of this type lies in its lack of rigidity. Its principal advantage lies in its freedom from temperature stresses and in the fact that vertical or lateral movements of the supports, unless they be of considerable magnitude, will not induce any material stress in the superstructure.

The three-hinged arch will probably require more metal than the fixed arch of corresponding dimension. No definite relationship has ever

¹ It will be shown in Art. 5, p. 368, that wherever a hinge is used, the line of thrust for the arch rib must pass through such hinge for every position of the loading, otherwise the structure would rotate about the hinge in question. Thus every hinge introduced provides one point of *definite location* for the otherwise unknown thrust line.

been established or data presented as to the relative economy of these two types of construction.

2e. Various Types in General.—In regard to the above types in general, it may be stated that the three-hinged type has been by far the most extensively used type of structure in America, but that the fixed arch is becoming more and more popular with American engineers. Where sufficient head room is provided so that the arch may be constructed with a generous rise, temperature stresses in this last type of structure do not assume very great importance. Flat fixed arches on the other hand may develop temperature stresses amounting to a large percentage of the total stress in the rib.

Arches in general are especially to be commended for their beauty of line and have been used in Europe to a much greater extent than in this country probably for the above reason. This type of construction is most adaptable to deep, rocky ravines where ample head room can be secured, and where natural foundations of the best are encountered. It is probably not the part of wisdom to place arch structures on pile foundations except perhaps arches having three hinges. It is true that some fixed arches have been constructed on foundations of this character apparently with satisfactory results; however, the cost of abutments of a size sufficient to distribute the eccentric arch thrust in such a manner as to provide safe bearing values on the foundation material or on the piling, will generally be so great as to eliminate this type of construction from competition for foundation conditions of this character.

3. Loadings on Arch Bridges.—The loadings for which an arch structure should be designed are as follows: (1) Dead load; (2) live load; (3) impact; (4) wind load; and (5) temperature and rib shortening.

Stresses resulting from dead load, live load and impact should be carried by the metal at the usual allowable unit stresses. It is permissible, however, to increase these stresses when considering the above loads in combination with wind or temperature; and to increase them still further when considering both wind and temperature stresses acting simultaneously. It is general practice to increase ordinary unit stresses of from 25 to 30 per cent for dead, live and impact loadings plus either wind or temperature. It is also customary to allow these original unit stresses to be

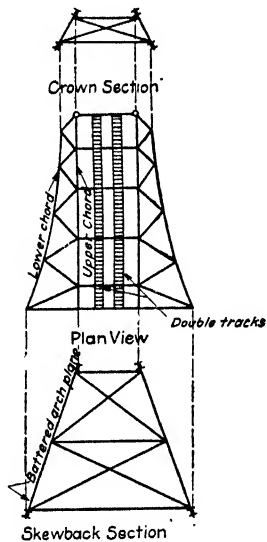

FIG. 12.—Showing method of inclining the planes of the arch frames to provide greater lateral stability at skewbacks.

increased up to 40 per cent when considering the above stresses together with wind and temperature acting simultaneously.

Steel arch bridges must be thoroughly investigated for wind stresses both as affecting the bracing and as affecting the trusses themselves. In many cases arch trusses have been erected in an inclined or battered plane, as shown in Fig. 12, so that the lower chord spread increases from crown to skewback. In this manner a greater stability against wind or other lateral forces can obviously be secured.

4. Erection of Arch Bridges.—The principal advantages in the span-drel-braced arch lies in the fact that it can many times be erected as a cantilever, thereby dispensing with false work and saving considerable in the cost of erection. It is also possible many times to so erect an arch bridge as to cause it to act as a three-hinged arch under dead load, or a portion of the dead load, afterwards fixing one or more of the hinges, thus causing the arch to act as a two-hinged or fixed arch under live load and impact. Figures 13 and 14 are construction views of a fixed rib arch structure that was erected across the Willamette River.

This structure was erected piece by piece from a scow derrick and the sections held in place by means of stay-cables running from old timber suspension bridge towers, as shown in Fig. 13. Figure 14 shows the structure connected up at the center. It will be noted that the central portion was not supported by stay-cables, but by bents resting on steel cables which had formerly been used to support the suspension bridge which crossed the river at this point. This structure as shown in Fig. 14 acts as a three-hinged arch. The hinges are detailed inside the rib and are not visible in the photograph. Figure 15 is a close-up showing the crown hinge which is placed inside the rib at the crown as shown. Figure 16 shows the skewback hinges and Fig. 17 the grillage upon which they set. At a certain point in the erection program, a milled plate was inserted at the crown to fill the key gap shown in Fig. 15, and a cover plate riveted over this, thus completely fixing the crown. The skewback hinges were then concreted in. (These hinges set back some 8 or 10 ft. into solid rock and the entire cavern was filled with concrete, thus completely fixing the ends of the rib.)

Comparative calculations were made for the total stresses resulting when the rib was assumed as being fixed at different stages of the erection, and it was found that a great deal of economy could be effected by allowing the rib to remain as a three-hinged arch until after the concrete floor was placed upon the structure because of the fact that some of the stresses induced when the structure was carrying load as a three-hinged arch were in a direction such as to counteract the stresses at the same point due to additional loading on a fixed arch. This fact, therefore, made it possible by properly combining the two actions, to decrease the

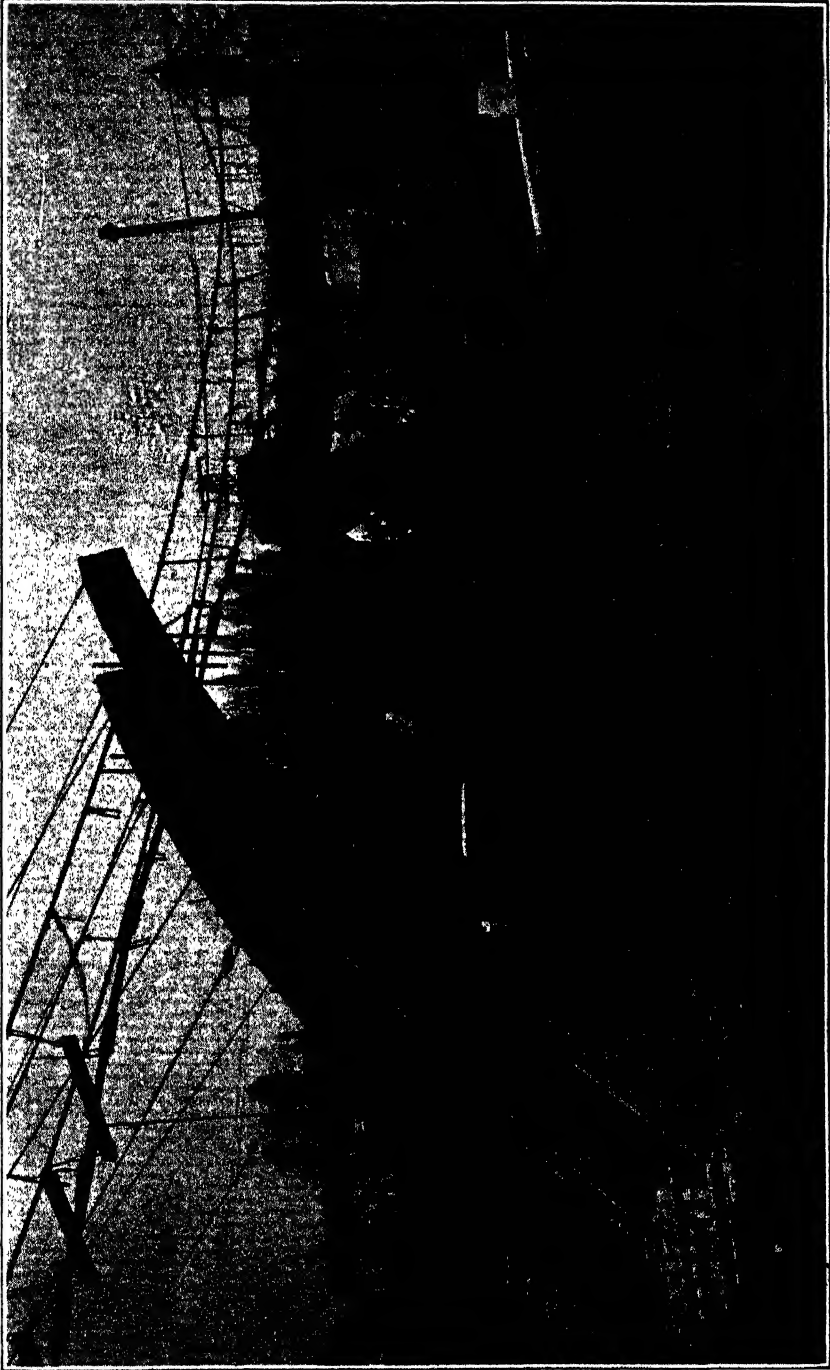

Fig. 13.—Erection of steel arch by means of radial stay cables.

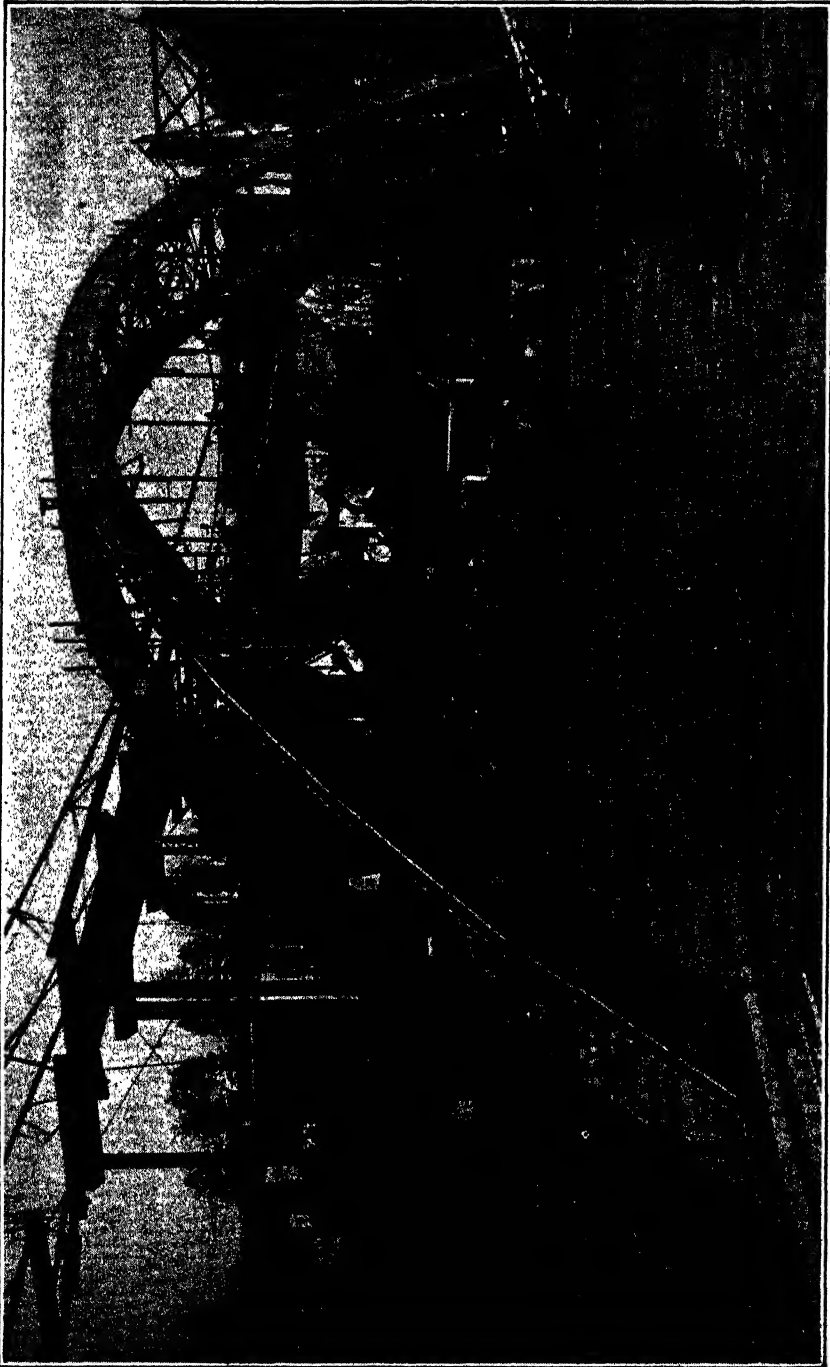

FIG. 14.—Arch shown in Fig. 13 completely swung.



FIG. 15.

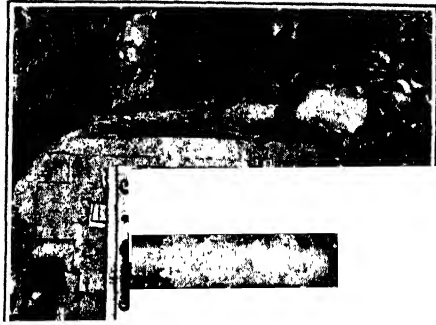

FIG. 16.

FIG. 15.—Oregon City Bridge. Temporary 7½-in. pin at crown. Used during erection. Splice plate driven into tapered gap and riveted after floor load was placed, thereby relieving hinge of further action.

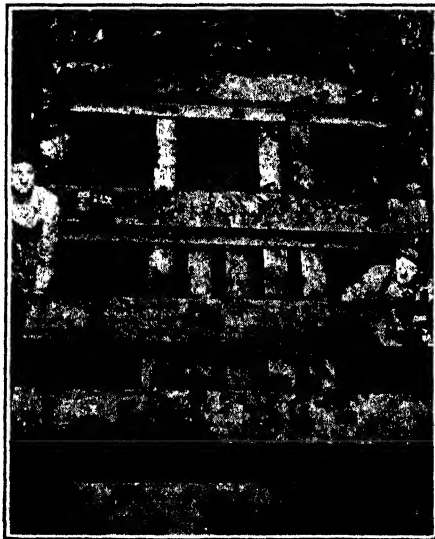

FIG. 17.

total dead load stress from the value it would assume if the arch were to be fixed either earlier or later in the erection program. A study of this kind, especially for this type of construction, will doubtless be found worth while in every case.

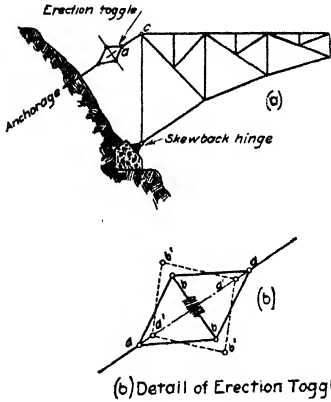

FIG. 18.—Cantilever method for erecting an arch frame.

Figure 18 illustrates a device sometimes employed for the erection of spandrel braced arches by the cantilever method. The erection member ac is pin connected to the upper chord end panel point and anchored back into the solid rock, or by means of “dead men.” Inserted in this tie member is a “toggle joint” or eyebar parallelogram as shown in Fig. 18b. By means of the toggle, points b are moved in or out, thus controlling the length of the tension member, and hence, the elevation of the cantilevered arm. This adjustment is necessary in order to

enable the arch to close at the crown. Either two- or three-hinged arches may be erected in this manner. When two-hinged spans are thus erected, the center panel must be made to close at a certain predetermined temperature—otherwise, temperature strains, other than those for which the structure was designed, are introduced.

5. General Design Features.

5a. Shape of Arch.—It will be clear from a consideration of the laws of graphic statics and from the discussion of Sec. 8 that the

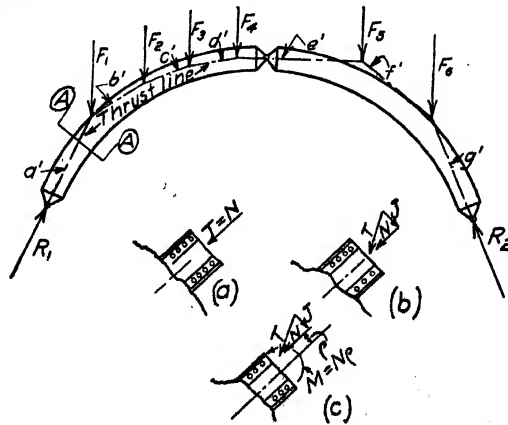

FIG. 19.

external forces and corresponding support reactions on any arch structure may be resolved into an “equilibrium polygon” or “thrust line” passing

through the rib or frame at or near its center. Thus in Fig. 19, the forces F_1 - F_6 inclusive together with the corresponding support reactions R_1 and R_2 may be completely replaced by the thrust line $R_1 - a'-b'-c' - R_2$.

If the three-hinged arch of Fig. 19 is loaded with the system F_1 - F_6 , such load, deflecting slightly, causes the arch to rotate about each hinge until it attains a deflected shape such that the thrust line passes through such hinge after which there can be no further movement. For any arch, therefore, under any load condition whatsoever, the thrust line (for equilibrium) must pass through every hinge.

If this same arch (Fig. 19) were to be fixed at crown and skewbacks, as shown in Fig. 20, it is clear that the rib would have a different deflection under the same load system (F_1 - F_6) and the corresponding thrust line

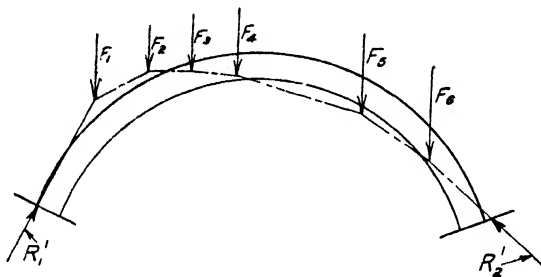

FIG. 20.

would not have the same position relative to the rib, but would have a position such as shown (greatly exaggerated) in Fig. 20. The support reactions R_1' and R_2' would be eccentric and would be of different magnitude and inclination from R_1 and R_2 of the three-hinged arch.

Referring back to Fig. 19 it will readily be observed that wherever the thrust line is normal to the rib and coincident with the neutral axis of the same, the stress consists of an axial thrust only. Wherever the thrust line is not normal but passes through the neutral axis (as shown in Fig. 19b), the rib stresses at that point consist of an axial thrust N and a shearing stress J . Whenever the thrust line fails to pass through the neutral axis of the arch rib, there is developed in addition to the above stresses a bending moment M equal to $N\rho$ (see Fig. 19c).

It is therefore seen that the introduction of a hinge at any point definitely locates the thrust line and reduces the bending moment to zero at this point. It should also be clear that the use of such hinge operates to cause the structure to deflect more readily under load. A hinged arch, as pointed out in a former paragraph, is therefore, less rigid than a fixed arch of the same dimension, but presents the advantage of definitely fixing the pressure line and causing it to pass through the same point for any load condition. The pressure line, of course, will move up or down between hinges with a change in load, but not at the hinges.

When the arch is fixed at the skewbacks, the pressure line acting against the foundations will shift under live load, causing a certain amount of "churning," or rocking tendency. A hinge at this point will fix the point of application of this thrust, although its direction will shift somewhat under moving live load. For foundations where rocking is particularly undesirable, such as pile foundations, a skewback hinge is thus seen to afford a distinct advantage even at the expense of decreased rigidity.

From the foregoing it should be apparent that arch ribs so designed as to keep the line of pressure at or near the neutral axis of the rib at all points, present the advantage of eliminating or reducing bending stresses and thus effecting a saving in metal. It is, of course, impossible to do this for moving live loads as these vary from time to time, thus shifting the pressure line, but for dead loads the pressure line may be made to pass very nearly through the neutral axis by a proper selection of the rib.

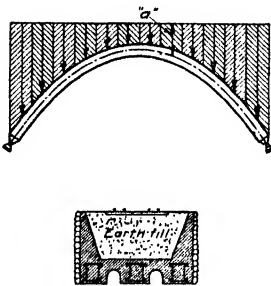

FIG. 21.—Method of loading which produces a "Catenarian" thrust line.

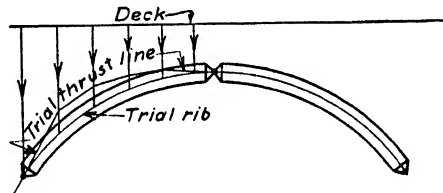

FIG. 22.—Method of selecting arch curve to coincide with the dead load thrust line.

For certain arrangements of dead load, the pressure line assumes certain definite curves which fact is often made use of in the preliminary selection of a curve for the neutral axis of an arch rib.

If the dead load varies as the distance a measured from the axis of the rib to a horizontal line, as shown in Fig. 21, the thrust line for the rib will take the shape of a transformed catenary. It will be seen that for a series of ribs covered with a slab and with walls at the faces retaining a filling of earth, this type of dead loading would be closely approximated. The arch rib in this case, therefore, should be made in the form of a catenary. Arches of steel with stone facing and solid stone spandrel walls exemplify this type of construction, as shown in Fig. 21.

If the dead load concentrations are equal and spaced equidistantly along the rib, the resulting thrust line will be a parabola with its vertex at the crown and its major axis vertical. Figure 6 is a rib design of this character.

Under other conditions of loading, the pressure line may take the form of a circle, an ellipse, or of what is known as the "geostatic curve" of Rankine. This last curve, however, is rarely used.

The most practical method of determining and selecting the most advantageous curve for the arch rib is probably the method of trial pressure lines as follows (see Fig. 22):

(a) Select a trial curve as near as possible to what the true thrust line will likely be and sketch in an assumed arch rib and spandrel posts.

(b) Compute the dead load weights including rib, columns or hangers, and deck.

(c) With these loads pass an equilibrium polygon or thrust line through the center of section at crown and at both skewbacks.

(d) This equilibrium polygon is the true thrust line for the loads assumed in the case of the three-hinged arch and a very close approximation in the case of the fixed or two-hinged arch.

(e) The arch rib axis is now corrected to correspond with the above thrust line, and the dead loads rechecked. The new dead loads will generally be so nearly identical with those first assumed as to make further calculation unnecessary. Should these loads differ from the original assumed loads by any considerable amounts, a new thrust line should be constructed and the rib axis again corrected to correspond therewith, and so on until the rib axis corresponds with the line of thrust for the dead loads used. Generally, the first trial will be sufficiently close, particularly in view of the fact that the rib is not yet designed and any dead load assumption may be somewhat in error. After the final design is made, the dead loads are recalculated, and if found to differ by more than 10 or 15 per cent, the arch axis may be corrected for the true dead loadings.

The above method is used for fixed as well as hinged arches, for, in any case, it is desirable to have the arch axis correspond in general with a dead load thrust line passed through the crown and skewback centers.

It is sometimes desirable to make the arch curve coincident with the thrust line for full dead plus live load so that the minimum eccentricity of pressure comes at the same time as the maximum value of thrust. Whether such a procedure will result in lower total stresses depends, of course, on the relative values of dead and live loadings, the shape of the rib, etc. For highway loadings, the dead load is by far the larger portion of the total load, and if the arch is designed for low bending under dead load, the live load bending will be relatively small. For railway loadings, this is not apt to be the case.

Spandrel-braced arches generally are designed with the lower chord panel points lying on, or nearly on, a parabola, although in some cases the catenary, the circle, the ellipse, and the hyperbola have been used.

5b. Temperature Stresses.—As the arch rib expands or contracts with varying thermal conditions, it will move upward or down-

ward at the crown to accommodate its position to the changed length of the rib or frame. The rib is forced to do this because unlike a truss span on rollers or rockers, the skewbacks cannot move laterally. If the arch is a three-hinged structure, the rib or frame will revolve about each hinge and no temperature stresses will result. If, however, one or more of the hinges are removed, the rib in moving up or down must bend somewhat, thus inducing what are termed *temperature stresses*.

A lowering of temperature will cause tension at the under side (*intrados*) of the arch at the crown and compression at the upper side (or *extrados*).

The magnitude of these temperature stresses is, of course, a linear function of the assumed variation in the internal temperature of the metal, which in turn varies greatly with varying conditions. In the *Annales d pont, et claus* (1893) will be found an account of some experiments on steel arches at Lyons, France. These tests disclosed an average temperature in the steel of $+115^{\circ}$ F. when the air temperature was $+90^{\circ}$ in the shade and $+95^{\circ}$ F. in the sun. Parts of the structure exposed to direct sunshine had a temperature of $+130^{\circ}$ F. The coldest winter temperature recorded was -15° F., giving a maximum range of 130° F. Assuming the arch fixed at mean temperature ($+50^{\circ}$ F.) a variation of 65° F. each way from the normal would seem a logical assumption. Where air temperature variations are less or where shade conditions operate to modify the temperature effects, a lower temperature range may safely be assumed.

5c. Location of Crown Hinge.—For rib arches, the crown hinge, when used, is generally located at the center of the rib. For spandrel-braced arches, the hinge may be placed either in the upper chord (as shown in Fig. 1), in the lower chord (as shown in Fig. 3) or mid-way between the two.

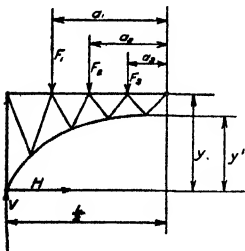

FIG. 23.

Taking moments about the center hinge (see Fig. 23) and considering the left half of the arch frame as a "free body in equilibrium," the expression for the horizontal thrust at the left skewback is:

$$H = \left[\frac{VL}{2} - \Sigma Fa \right] \div y$$

If the crown hinge be placed in the lower chord, the horizontal thrust becomes:

$$H' = \left[\frac{VL}{2} - \Sigma Fa \right] \div y'$$

It is thus seen that lowering the rise of an arch frame operates to increase the horizontal skewback component.

This generally results in increased stresses in the frame though not always. It is probable that the stresses throughout the frame will be less when the crown hinge is placed in the upper chord.

In general the greater the rise in any arch structure, hinged or fixed, the less the horizontal thrust. Temperature stresses will also be less for arches with high rise.

For a spandrel-braced arch having a crown hinge in the lower chord, the thrust line for dead load may be made to follow the lower chord line, thus reducing to zero the dead load stresses in upper chord and web system. For example, an arch such as shown in Fig. 1 of the next section having a parabolic lower chord will develop no dead load stress in the upper chord members, since the lower chord must carry the entire thrust. Since the dead load upper chord stresses are zero, the web system can carry no dead load stress except that induced by the transmission of the deck loads to the lower chord. When there are vertical web members, this simply means that each one will carry a dead load stress in compression equal to the dead load concentration above it. Under live load, however, both upper chord and web system will be called into action.

5d. Tied Arches.—It will be noted that in every case the reaction at the skewback of an arch bridge is inclined; that where skewback hinges are used, the direction of

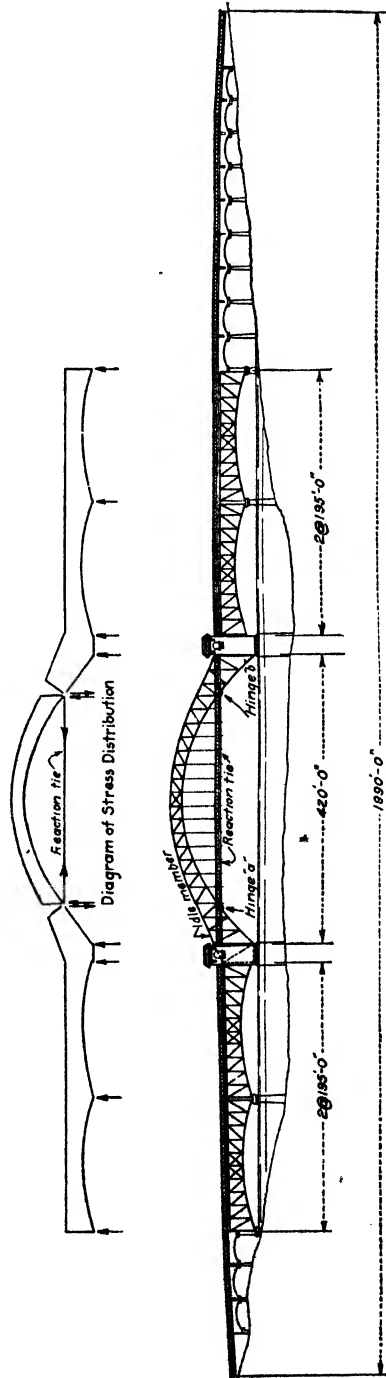

Fig. 24.—Diagram of "tied arch" bridge (vertical pier reactions).

the thrust is shifting under moving load, and that for fixed skewbacks, both the direction and point of application are shifting. These conditions all operate to increase the duty of the foundations and to create a tendency toward lateral as well as vertical settlement. It is sometimes possible to relieve this condition by inserting a horizontal tie between skewback hinges to absorb the horizontal thrust component, thus resulting in vertical and fixed abutment reactions. Such an arch is termed a *tied* arch and is illustrated in Fig. 24, the same being a preliminary sketch prepared in 1921 for a bridge structure at Sellwood, a suburb of Portland, Ore.

It is noted that the arch proper extends from *a* to *b* only, the balance of the steelwork being a cantilever or *umbrella* rigidly anchored to the pier

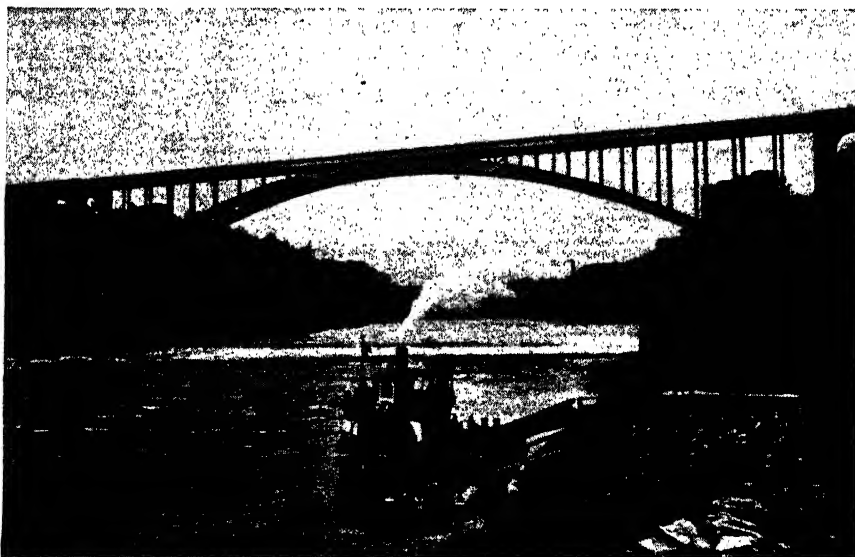

Fig. 25.—Rainbow Bridge, Niagara Falls. (Courtesy of Shortridge Hardesty.)

masonry and the adjacent approach spans which are designed as continuous trusses. The foundation conditions (boulder gravel and hard pan) indicated the necessity for vertical pier reactions. The truss continuity on the approach spans made the umbrella cantilever feasible, and the tied arch design results in the use of very little metal over and above that necessitated by the adoption of a simple truss span. The general outline of the structure, which is a boulevard bridge, is much more pleasing than that of a simple truss. Arches of this type have been constructed in Europe in several instances, notably the Rhine Bridge at Mainz. This bridge consists of a series of through tied arches of 306- to 384-ft. span. This structure was finished in 1904 and carries a double-track railway.

The great improvement in appearance of this type of construction over the simple truss span may make it a more popular type than formerly, particularly in view of the growing tendency on the part of municipalities at the present time to demand architectural as well as structural excellence in bridge design.

6. The Rainbow Bridge, Niagara Falls.—This bridge is not only an excellent example of fixed steel arch design but is also the longest of its type in the world (Fig. 25). It replaces a bridge that was destroyed by an ice jam early in 1938. To prevent the destruction of the new bridge under similar conditions, the spring line was raised some 30 ft. and the span increased to 950 ft. between skewbacks, with the rise of the arch ribs 150 ft. The deck is of reinforced concrete and has a total width of 60 ft. It has two 22-ft. roadways separated by a 4-ft. dividing strip and one 10-ft. sidewalk.

The ribs were erected by the cantilever method from each abutment. Each portion of a rib was held in position by a series of steel tiebacks until closure was made at mid-span. The erection of both ribs and bracing was carried on at the same time.

Approximately 3,300 tons of silicon steel and 2,200 tons of carbon steel were used in the arch span. The cost of the bridge was about \$3,000,000, and it was opened to traffic in the latter part of 1941.

7. Chesterfield and Orford Bridges, over the Connecticut River.—These highway bridges span the Connecticut River between the states of New Hampshire and Vermont (Figs. 26 and 27). They have been selected as representative of two-hinged and tied-arch construction. Each was designed under the same specifications and for the same loadings. Both have the same span and the same type of deck, and construction was started on both in the same year, 1936.

The Chesterfield-Brattleboro Bridge is a two-hinged arch and the Orford-Fairlee a tied arch. Both bridges have box girder type ribs, having a span of 425 ft. pin to pin and a rise of 85 ft. Each has a clear roadway of 24 ft. The Chesterfield bridge has a 2.5-ft. emergency walk on each side of the roadway inside the hangers, with the ribs 34.5 ft. on centers. The Orford bridge has a 2.5-ft. emergency walk on one side of the roadway inside of the hangers and a 5-ft. sidewalk on the other side outside the hangers, with the ribs 30.5 ft. on centers. The hangers of both bridges had a single-pin connection at their upper ends and a two-pin connection at their lower ends. The latter connection eliminated bending in the hangers from floor or deck loads.

At the Chesterfield site the Vermont abutment was carried to solid rock. The New Hampshire abutment was carried on a series of steel H-piles driven 55 ft. through compact gravel. The piles were used as insurance against possible erosion at the face of the abutment in the event the riprap should be dislodged by severe flood conditions.

Since sand and fine gravel existed for considerable depths at the Orford site, both abutments were carried on steel H-piles driven to depths of 60 to 70 ft. below the river bed. Because of the foundation

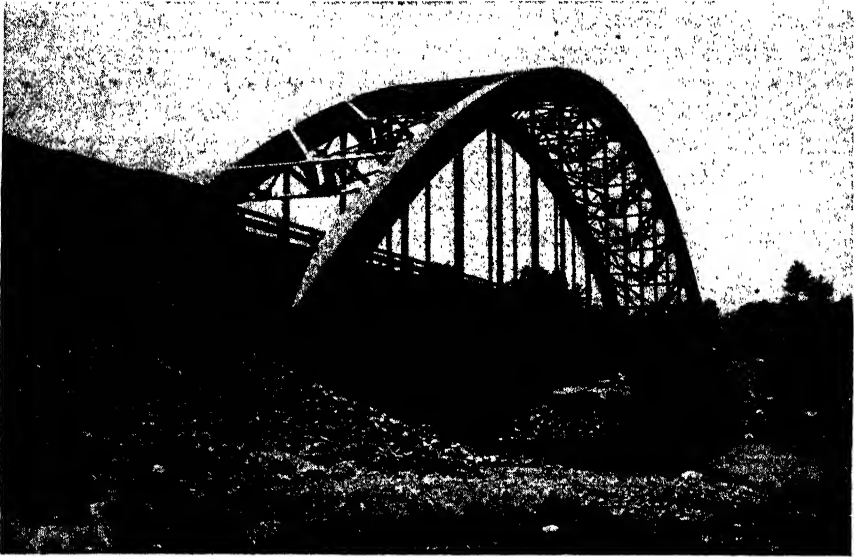

FIG. 26.—Chesterfield-Brattleboro Bridge, over Connecticut River.



FIG. 27.—Orford-Fairlee Bridge, over Connecticut River.

conditions a tied arch was adopted. The abutments were so designed that they were subjected to very little earth pressure; thus the piling carried principally vertical loads.

Erection conditions at the Chesterfield site were difficult, owing to the ledge on the Vermont side which lay on a steep slope with no overburden into which piles could be driven. This condition existed until near mid-span, at which point the water was about 50 ft. deep. An attempt to drive steel H-piles into the ledge was not successful. A diver, however, succeeded in preparing proper seats for the piles. In order to eliminate as many falsework bents as possible, the erector erected only the end portions of the span on falsework, cantilevering the ribs a short distance beyond the last falsework bents. The center portion of each rib, which was about 100 ft. long, was erected by means of two guy derricks placed on the floor system over the outer falsework bents. The balance of the erection was made in the usual manner.

The Orford arch was erected on falsework carried on timber bents. The falsework extended the entire length of the bridge. The average depth of water was about 10 ft., and the material of the river bottom proved very satisfactory for driving timber piles.

The following tabulation shows that the tied arch is considerably more expensive than the two-hinged type:

Bridge	Total cost of bridge	Cost of superstructure	No. of tons of steel
Chesterfield.....	\$202,000	\$135,000	750
Orford.....	\$231,200	\$153,100	970

It is believed that these figures give as accurate a comparison between the two types as can be secured. It is reasonable to conclude that the tied arch will cost at least 15 per cent more than a two-hinged or fixed arch.

SECTION 8

ANALYSIS OF THREE-HINGED ARCH BRIDGES

1. **Equilibrium Polygons.**—Figure 1 represents a common type of spandrel-braced three-hinged bridge arch under the action of a load system $\Sigma F = F_1 - F_9$, and in equilibrium under the action of these forces and the two skewback or support reactions R_1 and R_2 . Let it be required to determine the stress in each member of the arch due to this system of forces.

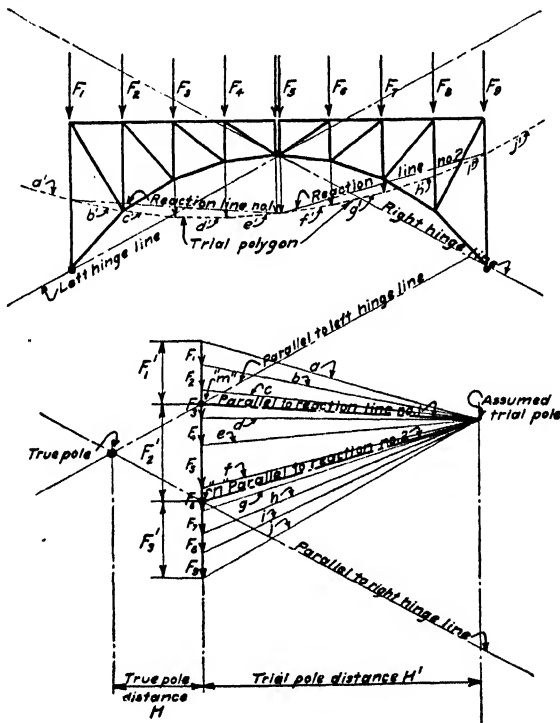

FIG. 1.

From the fundamental laws of graphic statics, the equilibrium polygon or thrust line must pass through the center of each hinge for, were this not the case, the eccentricity of such thrust line would induce a bending moment and the structure would rotate about the hinge in

question. Since it does not rotate, we must conclude that this thrust or pressure line acts through the center of each hinge.

To determine the shape of this equilibrium polygon, the forces F_1 to F_9 , inclusive are laid off on a vertical load line (vertical forces alone are here considered; inclined forces could obviously be treated in exactly the same manner), and an arbitrary trial pole assumed.

With this trial pole a ray diagram is constructed and from it a trial equilibrium polygon $a'b'c' \dots j'$ constructed. At the points where this trial equilibrium polygon intersects verticals through the hinges, two closing lines are drawn, these being designated "Reaction Line No. 1" and "Reaction Line No. 2," on the drawing (Fig. 1). If, through the assumed pole o , parallels be drawn to these reaction lines, it follows from the laws of graphic statics that such parallels divide the load line into the resultant load components F_1' , F_2' , and F_3' , which are transferred to the three respective hinges by each half of the arch frame acting as a simple beam.

It is obvious that the values of F_1' , F_2' and F_3' are entirely independent of the position chosen for the pole o and therefore, the reaction lines for any chosen pole including the true pole, will pass through these three points on the load line.

It is furthermore apparent that if the equilibrium polygon is to pass through the hinges, the closing line or reaction line in each case must be parallel to straight lines passing through these hinges designated "hinge lines" in Fig. 1.

Therefore a parallel to the left hinge line through point m , and a parallel to the right hinge line through point n intersect to locate the true pole o (see Fig. 1).

With this true pole and the given load line, a new ray diagram is now constructed and, from such ray diagram, a new equilibrium polygon drawn, as shown in Fig. 2. If this polygon be started through the left hinge, it will evidently pass through each hinge (if the work is correctly done), and thus define the true thrust or pressure line induced by the forces $F_1 \dots F_9$.

Bearing in mind the fact that this equilibrium polygon ($a'b'c' \dots j'$, Fig. 2) represents the resultant of the forces $F_1 \dots F_9$ and the corresponding support reactions, the stress in any member of the frame can be readily calculated as follows:

Stress in Chord Member U2-U3.—This stress is obviously the moment of the forces acting about $L3$ divided by the lever arm $L3-U3$ and may be found in several ways as follows:

(A) *Algebraically.*—The value of the left reaction R_1 which is equal in magnitude and direction to segment a of the ray diagram is readily determined. Then from Fig. 2a:

$$s \text{ (the stress in } U2-U3) = (R_1d - F_2a_2 - F_1a_1) \div p$$

(B) *From the Thrust Line.*—Bearing in mind that the resultant of R_1 , F_1 and F_2 is given in direction and magnitude by ray c of the equilibrium polygon (Fig. 2b).

$$s = (\text{ray } c') (r) \div \rho$$

(C) *From the Pole Distance H.*—Resolving the ray c' into vertical and horizontal components, as shown in Fig. 2c, the moment of the vertical component V about L_3 vanishes and

$$s = Hh \div \rho$$

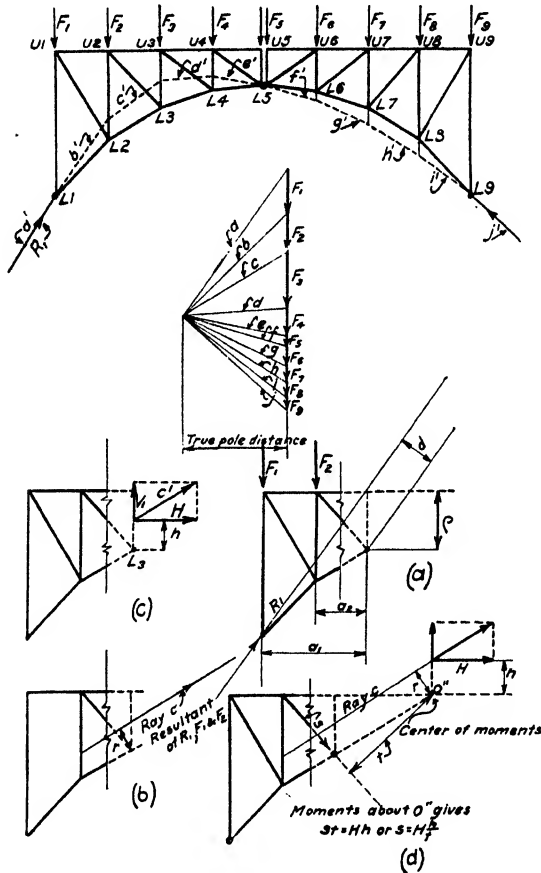

FIG. 2.

Stress in Web Member U_2 - L_3 .—Simply produce the chords to intersect at o'' which is obviously the moment center for the web member in question. With the left portion of the structure as a "free body in equilibrium" we have at once

$$s = \frac{Hh}{t} \text{ (see Fig. 2d)}$$

In this manner, the stresses in any member of the frame may be readily found and the analysis of stresses for the given load system quickly

completed. For dead loads or for fixed live loads, the above method answers every purpose; but for moving loads, the method of influence lines is much to be preferred. This method is described in Art. 4.

2. Algebraic Calculation of Reactions.—As a check on the accuracy of the graphical work outlined in the foregoing article, the horizontal and vertical reaction components may be computed by the formula given in Fig. 3. It will be observed that the vertical reaction components are identical with those for the same load system on a simple beam of span L . Removing the roller at one end and inserting the crown hinge thus transforming the frame from a truss to an arch has simply had the effect of introducing the horizontal thrust H .

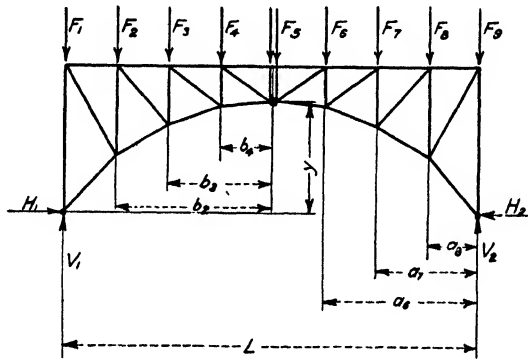

$$V_1 = \frac{\Sigma F a}{L}$$

$$V_2 = \Sigma F - V_1$$

Taking moments about crown hinge

$$H = \left[\frac{V_1 L}{2} - \frac{F_1 L}{2} - F_2 b_2 - F_3 b_3 - F_4 b_4 \right] \div h$$

$$H_2 = H_1$$

FIG. 3.

3. Stresses Due to Moving Loads (Method of Reaction Lines).—

Consider this same structure under the action of a single load F as shown in Fig. 4. The thrust lines must pass through the three hinges and the reaction components must be as shown, since three forces in equilibrium must intersect in a point. These reaction components may be checked by algebraic formulas, as shown in Fig. 4.

With the above in mind, let us now consider the chord $U2-U3$ (Fig. 5) and derive a method of determining what positions of a moving load will cause compression in this chord member and what positions will cause tension.

The stress in $U2-U3$ is a direct linear function of the moment about $L3$ and will therefore become zero or change sign when this moment does the same.

Through the left hinge $L1$ and the moment center $L3$ (Fig. 5), draw a straight line intersecting the right hinge line in the point c .

Clearly then, a vertical load passing through c will induce zero stress in chord member $U2-U3$.

For any load to the right of point c , the left thrust line passes below the moment center $L3$ and there is tension induced in the chord in question (see Fig. 5a).

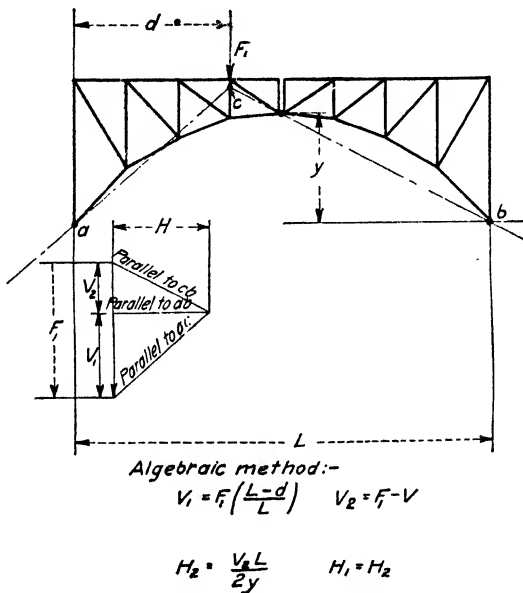

FIG. 4.—Reaction components for single unit load.

For any point between c and $U3$, the left thrust line passes above $L3$ and there is compression in the chord $U2-U3$ (see Fig. 5b).

For loads between $U2$ and the left end of the span, the above method does not hold for the reaction is no longer the only force acting on the left of section $m-m$. However, if the right-hand portion of the structure be taken as a free body in equilibrium (Fig. 5c), it is at once seen that the stress in chord $U2-U3$ is again compression.

In the above manner, the critical load positions for maximum stress of either sign can be determined for each chord member in the frame, thus enabling the designer to place his moving loads in such position as to determine the maximum stresses.

When the chords intersect within the limits of the drawing, the procedure for web members is much the same as indicated in Fig. 6. In this case, the chord members on either side of the web member in question are produced to intersect, locating the required moment center o' . A straight line drawn through the left hinge and point o' intersects the right reaction line at point p' , which is a point of zero stress in the diagonal in question. Figure 6 fully illustrates the entire procedure in determining the direction of stress for various load points.

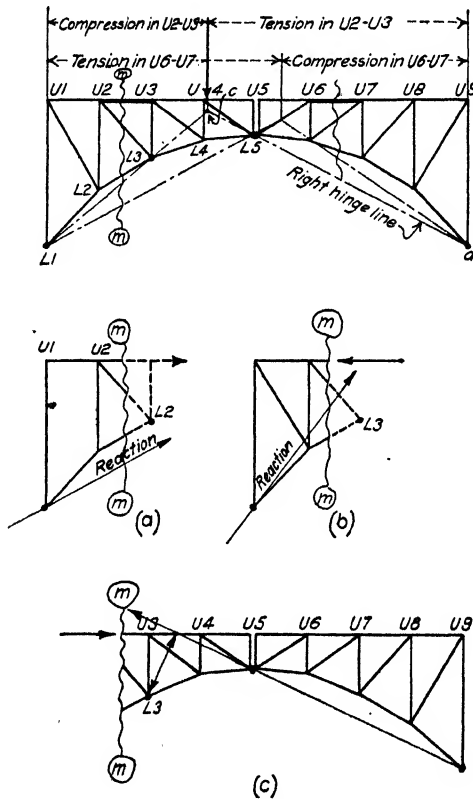

FIG. 5.

For the parallel curve arch shown in Fig. 7, the line through the left hinge is drawn parallel to the chords $U2-U3$ and $L2-L3$, intersecting the right reaction line in the point p' . Figure 7 illustrates the procedure from here on, which is analogous to that already explained. It is observed that, for a load at p' , the thrust line is parallel to the chords $U2-U3$ and $L2-L3$, and therefore there must be zero stress in the diagonal $U2-L3$. For a load to the right of p' , the left reaction has a downward component which must be balanced by compression in this diagonal (see Fig. 7b).

For a load between U2 and the left end of the span (taking the right-hand portion of the arch as a free body), there is an upward component of the right reaction that must be balanced by a compressive stress in the diagonal, and so on. Figure 7 should make the procedure entirely clear.

4. Influence Lines for Three-hinged Arches.—By taking moments about either hinge, the vertical reactions are seen to be identical with

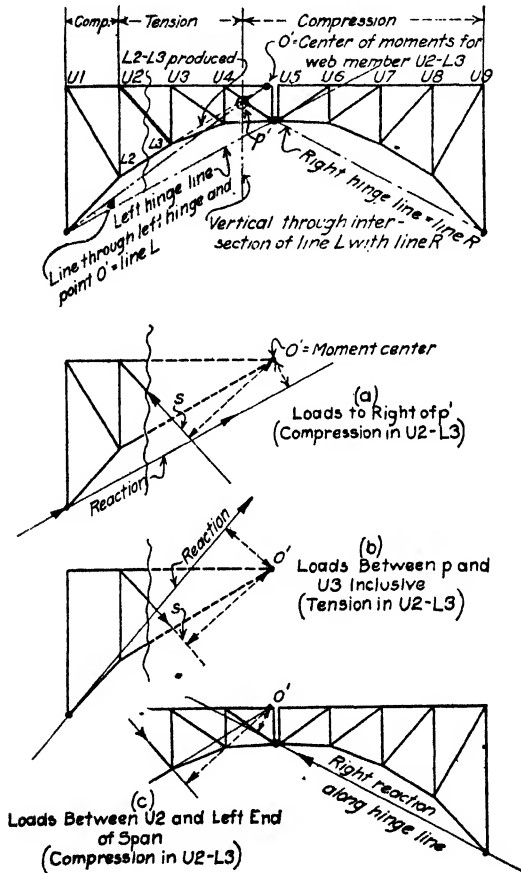

FIG. 6.

those for a simple truss of equivalent span, and are thus easily determined. Figure 8a is the influence line for the vertical component of the left reaction.

The horizontal reaction component is obtained by taking moments about the center hinge and is given by the expression

$$H = \frac{VL}{2y}$$

where y is the vertical distance between crown and skewback hinges. The influence line for the horizontal thrust is therefore plotted as shown in Fig. 8b. It is seen that this influence line is symmetrical about the vertical through the center hinge.

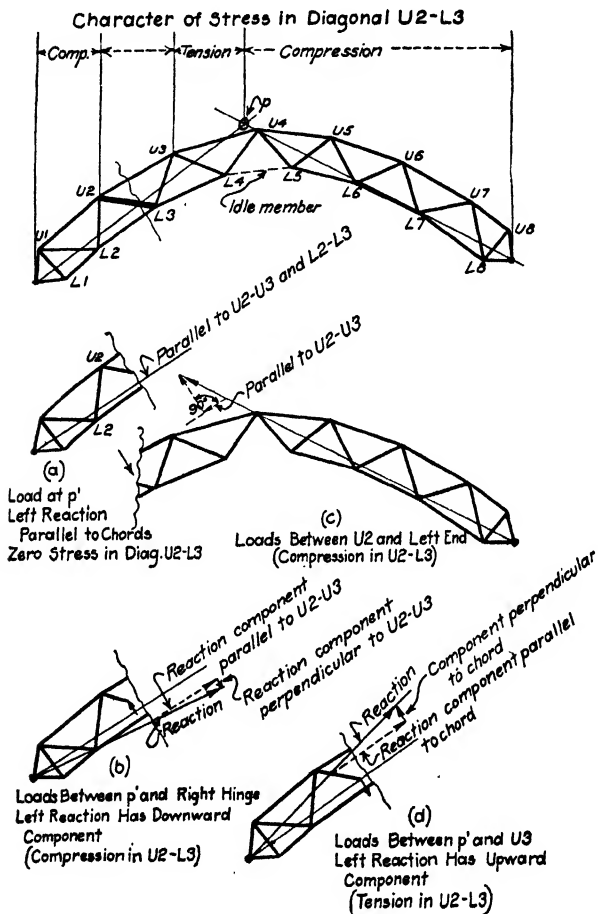

FIG. 7.

The influence line for the moment at point o (which will determine the influence line for the stress in chord $U2-U3$) is developed as follows (see Fig. 9):

The influence lines of the vertical reactions plot up in exactly the same manner as for a simple truss; thus the moment for a unit load at o is given by the expression

$$M_o' = \frac{ab}{L}$$

The moment induced by the horizontal thrust is given by the term

$$M_0'' = Hc = \frac{bc}{2y}$$

At the center $a = \frac{L}{2}$ and $M_0'' = \frac{Lc}{4y}$ (see Figs. 8 and 9).

Obviously the total moment $M_0 = M_0' - M_0''$ and the difference between the superimposed influence lines is the influence line for the true arch moment at $L3$.

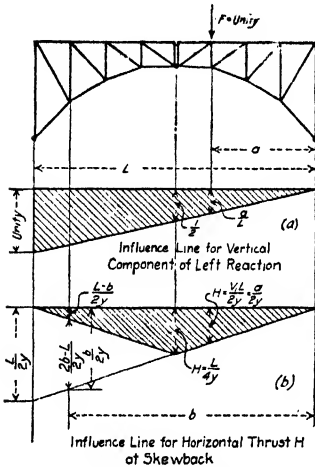

FIG. 8.—Influence lines for vertical and horizontal reaction components.

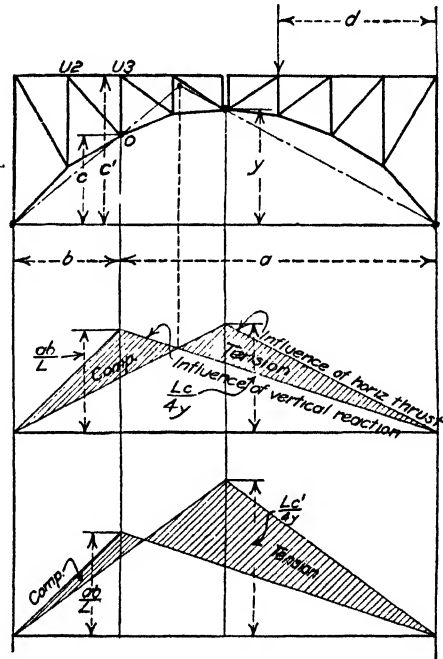

FIG. 9.

Figure 9 also shows the influence line for the moment at $U3$ (this will determine the influence line for the stress in $L3-L4$). It is noted that the only difference lies in the effect of the horizontal thrust which difference is represented by the difference in the values of c and c' .

Figure 10 illustrates the method used in developing an influence line for one of the web members.

The effect of the horizontal thrust is given by the expression $\frac{Hb}{t}$ and this portion of the influence line is readily plotted. For loads to the right of $U2$ (up to and including $U3$), the effect of the vertical reaction component at the left hinge upon the web member in question is given

by the term $\frac{Va}{t}$. For loads to the left of U3, the effect of the vertical reaction component (in this case, the right reaction component must be taken), is given by the expression $V(L - a) \div t$.

The influence line for the web member in question is therefore fully determined as follows:

- (a) Lay off the distance $\frac{Hb}{t} = \frac{Lb}{4yt}$ at the center, determining the point c.
- (b) Lay off the distance $\frac{a}{t}$ on a vertical through the left support, thus determining the point d.

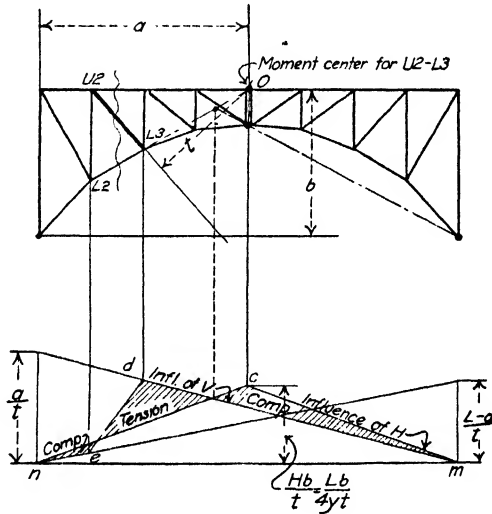

FIG. 10.

- (c) Lay off the distance $\left(\frac{L - a}{t}\right)$ on a vertical through the right support, thus determining the point e.

The area *mdencm* is clearly the influence area for the web member U2-L3.

For parallel chord construction, web stress influence lines are plotted in a slightly different manner (shown in Fig. 11) as follows:

Place a unit load at the center hinge and compute the stress in the web member in question due to the horizontal force *H*, neglecting the effect of the vertical reaction components *V*₁ and *V*₂. This determines the point *c*.

Next, considering the beam as a simple span, place a unit load successively at the panel points each side of the web member in question and

compute the stresses in such web member, ignoring in this case the effect of the horizontal thrust. This determines the points *d* and *e*.

Clearly, as in the former case, area *mcned* is the influence area for the stress in web member *U3-L3*.

The stresses in the above web member due to the various unit loads above mentioned, may be computed either algebraically or by graphics as may be found the more expeditious.

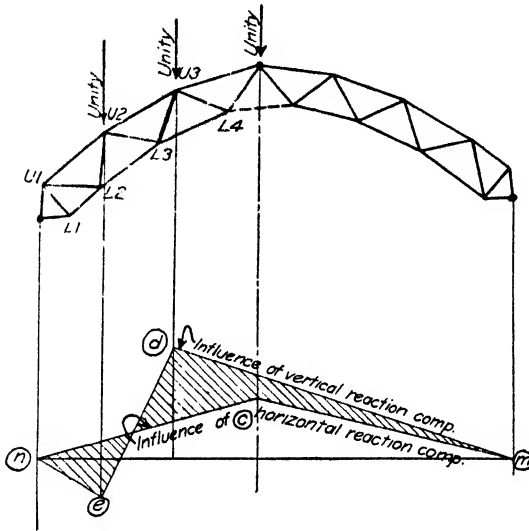

FIG. 11.—Influence line for stress in *L3-U3*.

5. Fiber Stresses in Solid Ribbed Arch Spans.—Consider the solid webbed or plate girder arch shown in section in Fig. 12.

The following formulas may be derived at once from statics:

$$\begin{aligned}
 M_g(\text{the moment at point } g) &= R'd \\
 &\text{or } N'c \\
 &\text{or } F_1a + H_1b - V_1a_1 \\
 N'(\text{the normal thrust}) &= R' \cos \phi \\
 J'(\text{the shear on section } AA) &= R' \sin \phi
 \end{aligned}$$

The moment thrust and shear at any section of the arch rib can be readily computed algebraically, once the reaction components for any given load condition are determined. These may also be determined from the equilibrium polygon constructed for the given load system.

Suppose the equilibrium polygon for a certain given load system to be constructed as shown in Fig. 12.

For any given point g

$$M_g = N'c$$

$$f'(\text{the fiber stress due to } M_g) = \frac{M_g e}{I}$$

$$f''(\text{the fiber stress due to the normal thrust } N') = \frac{N'}{A}$$

Whence f (the total fiber stress) = $f'' + f'$ (for the extreme upper fiber)
and $f'' - f'$ (for the extreme lower fiber)

Considering first the extreme upper fiber

$$\begin{aligned} f &= (f'' + f') = \frac{N'}{A} + \frac{M_g e_e}{I} \\ &= \frac{N'}{I} (r^2 + c e_e) \\ &= N \left(\frac{r^2}{e_e} + c \right) \frac{e_e}{I} \end{aligned}$$

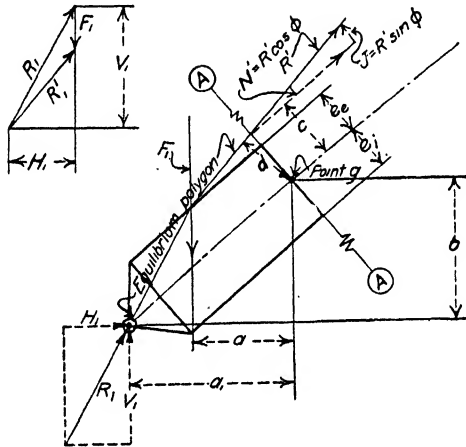

FIG. 12.

In a similar manner, the stress in the extreme lower fiber is given by the expression

$$f = N \left(\frac{r^2}{e_i} - c \right) \left(\frac{e_i}{I} \right)$$

where I = the moment of inertia of the rib section at the given point,
 e_e and e_i = the distances to the extreme upper and lower fibers respectively.

$$r = \text{the radius of gyration of the section} = \sqrt{\frac{I}{A}}$$

If the points k_1 and k_2 are so located on the arch rib section in question, that the distance of point k_1 below the neutral axis is equal to $\frac{r^2}{e_e}$ and the

distance of point k_2 above the neutral axis is $\frac{r^2}{e_i}$ these points (known as *kernal* points) are of considerable value in evaluating the fiber stresses in the rib during the passage of a moving load (see Fig. 13).

The maximum compression in the extreme upper fiber of the rib at section $a-a$ is given by the expression

$$f = N\left(\frac{r^2}{e_e} + c\right)\frac{e_e}{I} = (Nc')\frac{e_e}{I}$$

The maximum tension in the extreme lower fiber of the rib at this section is given by the expression

$$f = -\left[N\left(\frac{r^2}{e_i} - c\right)\frac{e_i}{I}\right] = (Nc'')\frac{e_i}{I}$$

where $c' = \frac{r^2}{e_e} + c$ and $c'' = -\left(\frac{r^2}{e_i} - c\right)$ (see Fig. 13).

It must now be clear that, if the kernal points for each section of the arch rib are plotted, the equilibrium polygon may be measured directly from these kernal points, giving moments Nc' and Nc'' , which are direct linear functions of the fiber stresses at the extreme upper and lower fibers of the section.

The "extradosal" kernal point k_1 is always plotted below the neutral axis and is used for scaling the ordinate c' which controls the stress in the extreme "extradosal," or upper fiber. When the thrust line lies *above* this kernal point, this stress is *compression*; when the thrust line lies below it, the *extradosal* fiber stress is *tension*.

The "intradosal" kernal point k_2 is always plotted above the neutral axis and is used for scaling the ordinate c'' which controls the stress in the extreme "intradosal," or lower fiber. When the thrust line lies *below* this kernal point, this stress is *compression*; when the thrust line lies *above* it, the *intradosal* fiber stress is *tension*.

It must therefore be apparent that whenever the thrust line passes between the kernal points, the entire section of the rib is in compression.

It is apparent that the influence line for the moment of the thrust line about the neutral axis of the rib would not be the same in form as that for the fiber stress on either extreme fiber, owing to the effect of the direct thrust N . However, moment influence lines for moments about the kernal points as above described, are exactly identical in form with influence lines for extreme fiber stresses and may be used to determine the position of loads for such maximum fiber stresses. The use of kernal

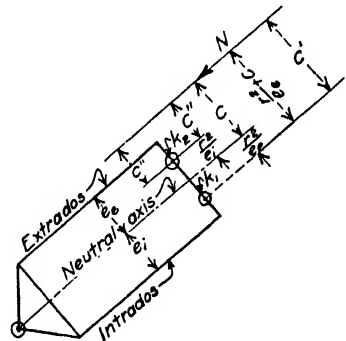

FIG. 13.

points is exceedingly valuable in studying the characteristics of any arch rib under moving loads.

6. Graphical Analysis of Stresses.—If considered more convenient, the stresses in any arch frame due to any fixed load condition, may be determined by graphics in the ordinary manner. It is, of course, first necessary to determine the horizontal and vertical reaction components at either skewback hinge, after which each joint of the frame is analyzed in succession as in the case of a simple truss or frame. The detail involved in this process is treated in any of the standard texts on graphical analysis.

7. Wind Stresses in Spandrel-braced Arch Spans.—Consider the three-hinged spandrel-braced arch in Fig. 14 under the action of the wind loadings shown. The upper panel points are under the action of certain wind load concentrations designated by the letter W (usually assumed at a certain value per lineal foot of chord) and the lower panel points under the action of similar loads W_1 .

When the hinge is placed in the plane of the lower chord at the crown, the upper lateral system cannot be made continuous from end to end of the structure, but must be interrupted at the crown to permit freedom of hinge movement.

The upper lateral system, therefore, can only transmit wind forces to the abutment hinge by virtue of its stiffness as a cantilever. A portion of these stresses is doubtless transmitted in this way from the central portion of the span back to panel point Uo and thence down the vertical cross frame to the hinge at LO . By far the greater portion of these forces, however, is transmitted vertically at each panel point to the lower lateral system by virtue of the cross frames or vertical sway bracing at such panel point.

The upper lateral system, therefore, may be considered to transmit a certain percentage of the total wind loadings active against its panel points, but, for the sake of rigidity, should doubtless be designed to withstand the entire wind pressure. For example, the upper lateral No. 3 should be designed for a stress equal to $2\frac{1}{2}(W + W') \sec \theta_s$ (see Fig. 14), although the actual stress is doubtless much less.

The upper lateral forces W are in a large measure transmitted to the lower system through the panel point cross frames (shown in Fig. 14) and thus exert an overturning moment on the rib. For example, the upper panel point wind concentrations at $U5$ on each side of the hinge amount to $\frac{W}{2}$ on the leeward truss and $\frac{W'}{2}$ on the windward truss.

We may assume that all of this force is transmitted through the vertical sway frames to $L5$ and $L5'$, and that the horizontal component of these forces is equally divided between $L5$ and $L5'$ which latter assumption is probably as near the truth as the limits of accuracy in the analysis

necessitate, providing the sway bracing is stiff. (If this bracing were to be composed only of tension members, the entire horizontal force $\frac{W}{2} + \frac{W'}{2}$ would be transmitted to one lower panel point.) The lower panel points at $L5$ and $L5'$ are, therefore, under the action of the horizontal forces W_1 and W_1' , and also the horizontal force $\frac{1}{2}\left(\frac{W}{2} + \frac{W'}{2}\right)$ transmitted thereto from the upper panel points at $U5$ and $U5'$.

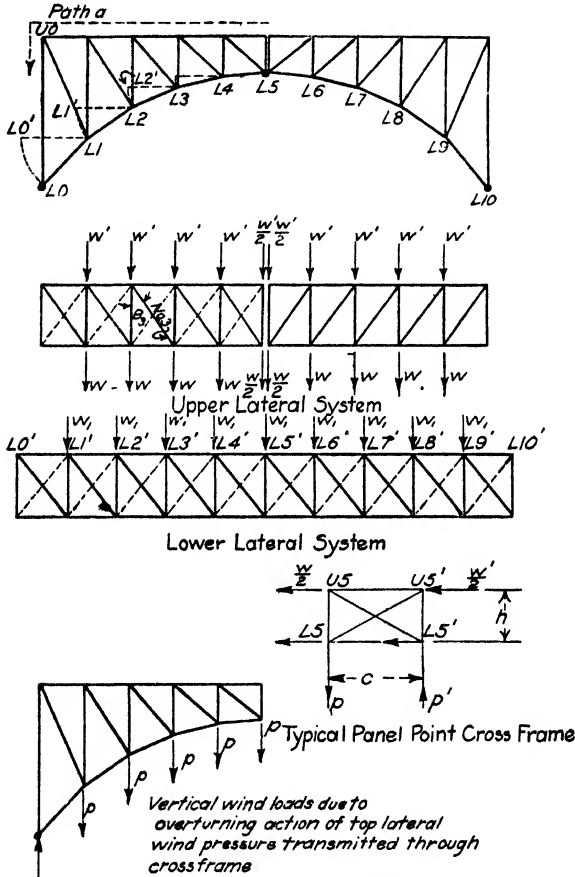

FIG. 14.

In addition to these horizontal forces, the overturning action induces a vertical downward force $p = \left(\frac{W}{2} + \frac{W'}{2}\right)\left(\frac{h}{c}\right)$ on the leeward side of the truss and an equivalent upward force p' on the windward side. These last forces induce stresses not in the lateral system, but in the main arch frame itself, in exactly the same manner as for any other vertical load system.

For this type of construction, therefore, the upper lateral system may be first assumed to transmit the entire wind forces active thereon through path *a*, Fig. 14, and this system together with the end cross frame designed accordingly.

The lower lateral system may next be designed, assuming it to carry horizontal loads due not only to its own wind concentration W_1 , but also to the full value of the upper panel point wind concentrations transmitted directly through each vertical cross frame and equally divided between the two trusses at each lower chord point. Before the analysis is made, it is, of course, necessary to develop the lower lateral system into a plane, as shown in Fig. 14, after which it may be treated as a simple truss span whose panel lengths are the actual developed lengths of the inclined chord members.

The main truss may next be analyzed for the vertical wind components due to the overturning action as above described. The leeward truss is under the action of the vertical downward loads $p = (W + W')\frac{h}{c}$, where W and W' are the upper panel wind loads, h = the height of the truss at the panel point in question, and c = the distance center to center of trusses.

The windward truss has exactly equivalent wind stresses, but opposite in sign.

It will be observed that the plane of the lower lateral system is not horizontal and, therefore, the diagonal members intersecting at each panel point have vertical components which must be carried by the arch system itself. An arrangement such as this results, therefore, in an additional system of vertical loads acting downward at the leeward panel points and upward at the windward panel points. The value of such wind components may be determined as follows:

Consider the arch shown in Fig. 15 and let $W_1 \dots W_5 \dots W_1$ represent the total wind load active against one lower chord, including the load transferred to the lower chord panel points through the vertical cross frames. $W_1' \dots W_5' \dots W_1'$ are equal forces applied to the other arch frame.

These forces applied at the lower chord panel points exert an overturning moment at each panel point which must be resisted by stresses in the arch frame itself.

Consider the lower lateral frame as a cantilever free at the crown and let Fig. 15*a* be a vertical projection of the same. Cutting the section at *a-a* just above panel point *L2*, the moment tending to overturn the frame about *L1* as a pivot (and thus causing motion as represented by the dotted arrow) is given by the expression

$$M = (\text{shear at } L2) (h_2)$$

The overturning effect must be resisted by the strength of the arch frame itself. Therefore, the arch must develop two equal and opposite vertical reactions at panel point L_2 whose value p is given by the expression

$$p = (\text{shear at } L_2) \frac{h_2}{c}$$

where c is the distance center to center of arch frames.

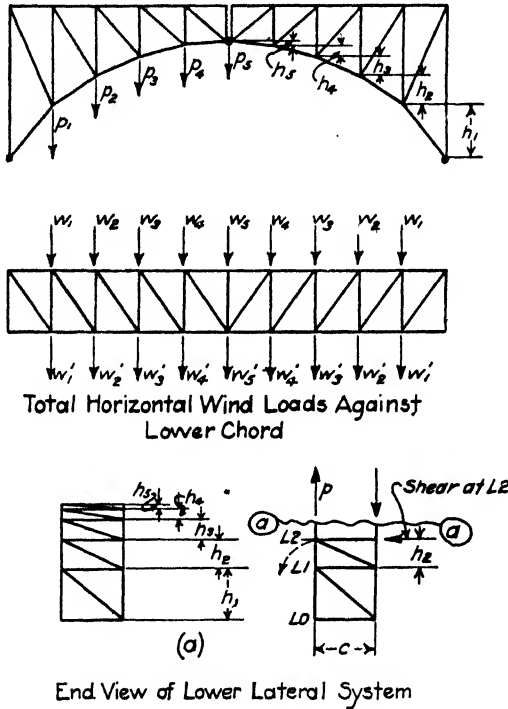

Fig. 15.—Overturning due to wind pressure on inclined lower chord.

In this manner all the vertical panel point wind reactions from this cause may be readily calculated thus:

$$p_1 = (\text{shear at } L_1) \frac{h_1}{c} = \left[\begin{matrix} w_1 + w_2 + w_3 + w_4 + \frac{1}{2}w_5 \\ + w_1' + w_2' + w_3' + w_4' + \frac{1}{2}w_5' \end{matrix} \right] \frac{h_1}{c}$$

$$p_2 = \left[\begin{matrix} w_2 + w_3 + w_4 + \frac{1}{2}w_5 \\ + w_2' + w_3' + w_4' + \frac{1}{2}w_5' \end{matrix} \right] \frac{h_2}{c}$$

$$p_3 = (w_3 + w_4 + \frac{1}{2}w_5 + w_3' + w_4' + \frac{1}{2}w_5') \frac{h_3}{c}$$

$$p_4 = (w_4 + \frac{1}{2}w_5 + w_4' + \frac{1}{2}w_5') \frac{h_4}{c}$$

$$p_5 = \frac{1}{2}(w_5 + w_5') h_5$$

The forces on the windward side act in a direction opposite to those on the leeward side. It is necessary, therefore, only to assume these forces as acting downward and compute the stresses for one truss. The stresses for the other truss are obviously of equal magnitude, but opposite in sign.

The above discussion should be sufficient to give a very clear idea of the general method pursued in the computation of wind stresses in three-hinged arch bridges where the crown hinge lies in the lower chord. For other hinge arrangements, the method will, of course, differ in detail, but will be the same in principle. For railway bridge structures, it is usually customary to consider in addition to the above loads, the effect of a wind load applied against a moving train. These loads are horizontal

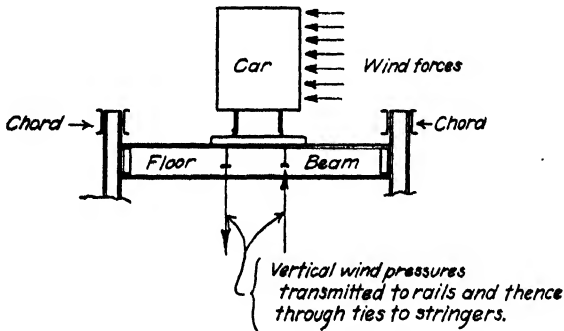

FIG. 16.—Vertical wind forces due to overturning action of wind against train.

and are transferred to the upper lateral system by means of the stringers and floor beams. From the upper lateral system, these loads are carried either to the end cross frame and down, or else vertically down through the cross frames at each panel point and thence via the lower lateral system to the skewbacks, as in the case already discussed. It will be noted that the wind forces acting against the side of the train induce an overturning moment which is resisted by vertical pressures from the rails, as shown in Fig. 16. These forces which act downwardly on the leeward side of the arch must also be taken into consideration in a complete analysis of wind stresses.

Space will not permit of further discussion of the many problems involved in the calculation of wind stresses. However, it may be said that no new theory need be developed other than that already discussed in this connection and in connection with the design of wind and portal bracing for simple structures.

SECTION 9

ANALYSIS OF FIXED ARCHES

FUNDAMENTAL THEOREMS RELATING TO INTERNAL WORK IN RIBS AND FRAMES

The analysis of the fixed arch is based upon what is generally known as the mathematical theory of elasticity. The fundamental elastic equations which form the basis of this theory may be derived from a consideration of any one of several basic mathematical concepts, for example:

- (1) From a consideration of Castigliano's theorem regarding the partial derivatives of the internal work.
- (2) From a consideration of the law of mutual elastic equilibrium or virtual work.
- (3) From the laws governing elastic displacements in ribs and frames.

Any one of the above methods yields a series of elastic equations practically identical in form. The last named method of derivation, namely, that based upon a consideration of elastic displacements—has been chosen for this discussion because of its comparative simplicity.

In order that the application of this theory of analysis may be thoroughly understood, it is necessary to preface the treatment of arch analysis proper by a brief consideration of the fundamental laws of internal work in ribs and frames. This consideration forms the subject matter of the present chapter.

1. The Laws of Internal Work in Structural Frames.—The structural frame, which as hereinafter treated may be made to include the solid web structure as well (see Art. 4), may be regarded as a machine in motion. The motion is intermittent, occurring only when the equilibrium of the system is disturbed, as when loads are added, altered, or removed from the structure.

Consider any elastic framed structure under zero loading and having zero stress in each of its members. As external loadings are gradually applied, a slight change in form takes place, the points of application of the external loads execute small displacements, and the internal stresses, which are now set up in the various members, are moved through small distances equal in each case to the distortion in the member. At

the instant of application both external loads and internal stresses have zero values from which they increase gradually and simultaneously, reaching their maximum values at the same instant.

If, at any instant, the value of any external force is F , its average value during the period of application is obviously $(F + 0) \div 2$, or $\frac{1}{2}F$. If the displacement of the point of application of this force parallel to its line of direction be represented by the symbol Δ , it follows from the laws of mechanics that the work done by the force thus far may be represented by the expression $\frac{1}{2}F\Delta$.

The total work performed thus far by all the external forces of the system is obtained by simply summing the terms $\frac{1}{2}F\Delta$ for each external force acting, thus

$$W_E = \frac{1}{2}\Sigma F\Delta \quad (1)$$

As the loading has progressed each of the members has been required to change length, by a certain small amount λ , in order to accommodate itself to the new distorted shape of the frame. This linear distortion has in turn induced a stress in each member whose value at this instant is S and whose average value during the period of loading is obviously $(S + 0) \div 2$, or $\frac{1}{2}S$. The internal work performed by each member in resisting distortion is therefore

$$\frac{1}{2}S\lambda$$

and for all the members of the frame, we may write

$$W_I = \frac{1}{2}\Sigma S\lambda \quad (2)$$

At the instant of application of loading the structure is at rest, the *kinetic energy* or *energy of motion* is zero, and the condition is one of *static equilibrium*.

The application of the load *disturbs the balance* and the machine is set in motion. The term $\frac{1}{2}\Sigma F\Delta$ at any instant represents the *externally applied work*. The term $\frac{1}{2}\Sigma S\lambda$ represents the work of resistance or the work which must be overcome by the external work. Obviously, the difference between these two values represents the amount of external work available for imparting kinetic energy or energy of motion to the structure, so that we may write for any instant during the motion

$$\frac{1}{2}\Sigma F\Delta - \frac{1}{2}\Sigma S\lambda = \text{Kinetic energy imparted to structure}$$

As the loading progresses, more and more of the kinetic energy is absorbed by the internal members until a point is reached where the internal and external work just balance. We then have

$$\text{Kinetic energy} = \frac{1}{2}\Sigma F\Delta - \frac{1}{2}\Sigma S\lambda = 0 \quad (3)$$

and the structure again comes to a point of rest.

This second rest point may be termed a condition of *elastic equilibrium*, whose fundamental law may be stated thus:

$$W_I = W_E \quad (4)$$

This equality furnishes the basis for the determination of stresses in all structures not susceptible of analysis from the laws of pure statics.

Whenever a force and the displacement of its point of application act in the same direction, the sign of the work is positive. When the direction of the force is opposite to that of the displacement, the sign of the work is negative.

In general, the external forces representing loads are displaced in the same direction in which the force acts though this is not always true. The internal work, however, is *negative* as the displacements of the extremities of the members are *opposite* in direction to the tendency of the stress.

To illustrate, a tensile stress in any member operates to pull the pin points at its extremities together, while the actual displacement is a movement in the opposite direction (a lengthening of the member).

The internal work may also be regarded as negative in the sense that it represents the stored-up energy of resistance, the resilient energy of the structure. As the loads are gradually released, it is this energy that operates to bring the structure back to its normal position, and, in changing from a *negative* value to *zero*, it performs positive work.

From Hooke's law of stress and strain proportionality, it follows that the term λ in Eq. (2) may be replaced by the expression $\frac{Sl}{AE}$ where S represents the stress in the member, l its length under zero stress, A its cross-sectional area, and E the modulus of elasticity of the material of which it is composed. We may therefore write, for bodies in elastic equilibrium

$$\frac{1}{2} \Sigma F \Delta = \frac{1}{2} \Sigma \frac{S^2 l}{AE} \tag{5}$$

which is, in certain cases, a more convenient form for practical use.

For a uniform change in temperature of t degrees, the internal stress in each member of the frame increases gradually from the value S to the value $(S + S_t)$, the average value during the change being $(S + \frac{1}{2}S_t)$. During this time the strain or distortion is represented by the expression $\lambda_t = c t l$, where c is the coefficient of expansion and l represents the length of the member. The total internal work is therefore given by the expression

$$W_{i,t} = \Sigma S c t l + \frac{1}{2} \Sigma S_t c t l$$

The external work, since the forces F remain at a constant value, is obviously

$$W_{E,t} = \Sigma F \Delta_t$$

where Δ_t represents the displacement of the point of application of each force due to internal temperature strains.

Equating these two, we may write

$$\Sigma F\Delta_i = \Sigma Sct_l + \frac{1}{2}\Sigma S_i c_t l \quad (6)$$

for any structural frame at rest and in elastic equilibrium.

In general the term S_i is zero for simple spans and cantilevers. In other words the frame, being free to move, simply adjusts itself to the new lengths of its members and is therefore unstressed under temperature changes.

If any of the supports are elastic, the corresponding reactions are moved through certain displacements Δ , and thus perform *negative* work (negative because the force and its displacement act in opposite directions). We may then write Eq. (5)

$$\frac{1}{2}\Sigma F\Delta - \frac{1}{2}\Sigma R\Delta_r = \frac{1}{2}\Sigma \frac{S^2 l}{AE} \quad (7)$$

In other words, a portion of the externally applied work $\frac{1}{2}\Sigma F\Delta$ must be consumed in overcoming the *elastic resistance* of the supports and consequently the work $\frac{1}{2}\Sigma \frac{S^2 l}{AE}$ absorbed by the internal system will be less by that amount.

The complete work equation, including the effect of temperature changes and reaction displacements may be written

$$\frac{1}{2}\Sigma F\Delta + \Sigma F\Delta_i - \frac{1}{2}\Sigma R\Delta_r = \frac{1}{2}\Sigma \frac{S^2 l}{AE} + \Sigma Sct_l + \frac{1}{2}\Sigma S_i c_t l \quad (8)$$

The term Δ as herein used does not refer to the actual movement of the point of application of a force, but to the component of this movement parallel to the line of direction of the force, otherwise the above equality does not hold. Unless otherwise specifically defined, the terms Δ and δ are used in this sense through the discussion.

In the application and derivation of the theorems which form the subject matter of this and subsequent chapters, it will be understood that:

- (1) All deformations are within the elastic limit of the material.
- (2) Any change in form, either of a beam or a frame is slight. (This is in accordance with observation of ordinary engineering structures under loads within the elastic limit.)
- (3) Tensile stresses and strains of elongation are considered as positive; compressive stresses and strains are considered as negative.

2. Deflections and Panel Point Displacements in Frames.—Consider the curved cantilever frame, shown in Fig. 1, at rest and under zero loading. If any load F_b , acting in any direction, and applied at any panel point b , is imposed upon the frame, the same will cause a distortion of the members and a deflection of the frame.

Let it be required to find the *vertical* deflection of panel point *c*, due to this load F_b , applied at panel *b*.

- Let S = stress in any member of the frame due to the load F_b .
- λ = distortion in such member due to the stress S .
- Δ_{bb} = displacement of panel point *b* (measured parallel to the line of action of F_b) due to the force F_b .
- Δ_{bc} = desired *vertical* deflection of panel point *c* due to this same load.

From the equality of internal and external work stated in Eq. (5), we may write (for the load F_b alone)

$$\frac{1}{2}F_b \Delta_{bb} = \frac{1}{2} \sum \frac{S^2 l}{AE} \tag{9}$$

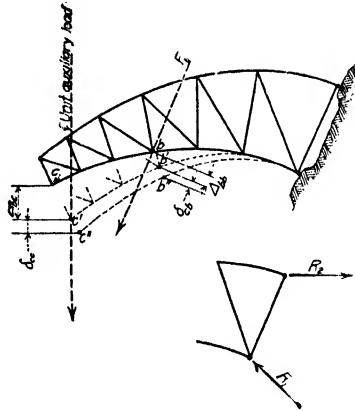

FIG. 1.

Now let us apply an auxiliary load equal to unity at panel point *c*, acting in the direction in which it is desired to determine the deflection (in this case *vertically*).

- Let s_c = stress in any member of the frame due to this unit load.
- δ_{cc} = vertical displacement at panel point *c* due to this unit load.
- δ_{cb} = displacement at panel point *b* due to this unit load measured along the line of action of the force F_b .

The addition of this unit load has increased both the internal and external work as follows:

$$\text{Additional internal work} = \sum (S + \frac{1}{2}s_c) \frac{s_c l}{AE}$$

$$\text{Additional external work} = \frac{1}{2}(\text{Unity})\delta_{cc} + F_b \delta_{cb}$$

These two according to the preceding article must be equal, therefore

$$\frac{1}{2}\delta_{cc} + F_b \delta_{cb} = \sum \frac{S s_c l}{AE} + \frac{1}{2} \sum \frac{(s_c)^2 l}{AE} \tag{10}$$

If the above two loads were to be applied simultaneously, equating the internal work to the external work would yield the following expression:

$$\frac{1}{2}F_b(\Delta_{bb} + \delta_{cb}) + \frac{1}{2}(\text{unity})(\Delta_{bc} + \delta_{cc}) = \frac{1}{2}\Sigma(S + s_c)^2 \frac{l}{AE}$$

or

$$\frac{1}{2}F_b\Delta_{bb} + \frac{1}{2}F_b\delta_{cb} + \frac{1}{2}\Delta_{bc} + \frac{1}{2}\delta_{cc} = \frac{1}{2}\Sigma \frac{S^2 l}{AE} + \Sigma \frac{Ss_c l}{AE} + \frac{1}{2}\Sigma \frac{(s_c)^2 l}{AE} \quad (11)$$

If all loads were released and the unit load alone applied to the structure, equating the internal and external work would yield the following expression:

$$\frac{1}{2}(\text{Unity}) \delta_{cc} = \frac{1}{2}\Sigma \frac{(s_c)^2 l}{AE} \quad (12)$$

Substituting from Eqs. (9) and (12) in Eq. (11) and cancelling like terms we have

$$\frac{1}{2}F_b\delta_{cb} + \frac{1}{2}\Delta_{bc} = \frac{\Sigma Ss_c l}{AE} \quad (13)$$

Substituting from Eq. (12) in Eq. (10) and cancelling like terms, we have

$$F_b\delta_{cb} = \frac{\Sigma Ss_c l}{AE}$$

or

$$\frac{1}{2}F_b\delta_{cb} = \frac{1}{2}\Sigma Ss_c l \quad (14)$$

Substituting for $\frac{1}{2}F_b\delta_{cb}$ in Eq. (13), cancelling and multiplying by two on each side, we have

$$\Delta_{bc} = \frac{\Sigma Ss_c l}{AE} \quad (15)$$

This is the expression for the desired deflection Δ_{bc} and may be expressed by this important rule:

To find the displacement or deflection of any point in a structural frame in any given direction and under any given set of load conditions, proceed as follows:

(1) Place an auxiliary unit load at the panel point at which the deflection is desired. This auxiliary load is to be assumed as acting in the direction along which the deflection is desired.

(2) Compute the stresses in the given frame due to the given loadings, calling these stresses S .

(3) Compute stresses in each member of the frame due to the auxiliary unit load, calling these stresses s .

(4) Compute for each member of the frame the length l and the cross-sectional area A .

(5) The desired deflection Δ is then given by the expression

$$\Delta = \frac{\Sigma Ss_l}{AE} \quad (16)$$

the summation being for each member of the frame.

The above law is entirely general and can be applied to *any frame* for *any load or set of loads* and for the calculation of deflections in *any direction*. For example, if the unit auxiliary load shown in Fig. 1 had been taken as horizontal the values of s_c would have been entirely different and the result would have expressed the *horizontal* displacement of panel point c .

If the result comes out negative, it simply indicates that the true movement is opposite in direction to that assumed for the unit load in computing the values of s .

Temperature Displacements.—If, instead of the load F_b of the preceding discussion the vertical deflection at panel point, c , due to a change in temperature were desired, we have only to reason as follows:

The deflection Δ_{bc} was caused by the linear distortion in the various members due to the load F_b , which linear distortion was represented by the expression $\frac{Sl}{AE}$. A change in temperature of t degrees will, obviously, distort each member an amount $\lambda_i = ctl$, where c is the coefficient of thermal expansion, and l is the length of the member. If this distortion is substituted for the distortion $\frac{Sl}{AE}$ due to the load F_b , we may at once write the expression for temperature deflection at panel point c as follows:

$$\Delta_{tc} = \Sigma s_c(ctl) \quad (17)$$

Δ_{tc} represents the displacement of panel point c due solely to a uniform change in temperature of t degrees in the various members of the frame and is measured in the *direction assumed for the auxiliary load* (in this case vertical).

Effect of Reaction Displacements.—Throughout the foregoing the supports have been considered as inelastic, in which event the work done by the reactions is zero. If, however, these supports do yield under load, the work done by the reactions is not zero and must be considered.

Consider, as an illustration, the case shown in Fig. 1. The effect of the rigid anchorage at the right-hand end of the cantilever beam may be represented by two reactions R_1 and R_2 , whose numerical value and direction of action may be easily determined from statics.

If each of these reactions is supplied by supports which are *elastic or yielding*, it is apparent that the movement of the same will have an effect upon the deflection Δ_{bc} , as determined above.

If these two elastic supports were to be removed and *elastic frame members* (resting in turn upon rigid supports) inserted in their stead (as shown in Fig. 2) it is at once apparent that the deflection at any point such as Δ_{bc} remains unaltered—*provided, the movement of these new frame members is the same as that of the yielding supports.*

Let

Δ_r represent the movement of any elastic support under the given loading.

r_c represent the reaction at this same support induced by a *unit auxiliary load at point c.*

Applying Eq. (15) to this new frame we have

$$\Delta_{bc} = \frac{\Sigma S s_c l}{AE} + \frac{\Sigma S' s'_c l'}{A'E'} \tag{18}$$

where S', s'_c, l' , etc. refer to the *two new frame members.*

Since from the original hypothesis these two new frame members exactly reproduce the movement of the original elastic supports, we may write, for each support

$$\Delta_r = \frac{S'l'}{A'E'} \tag{19}$$

Also, from inspection

$$r_c = s_c \tag{20}$$

Therefore

$$\Delta_{bc} = \frac{\Sigma S s_c l}{AE} + \Sigma r_c \Delta_r \tag{21}$$

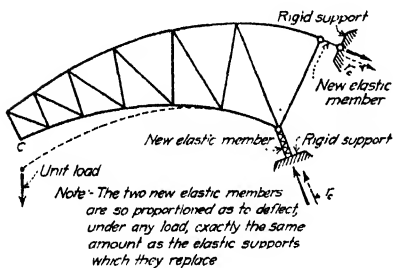

FIG. 2.

The effect of support displacements, in general, is very slight in well-designed arch construction and ordinarily is not considered in the analysis. For particular cases, however, it becomes necessary to consider the elastic movement of the abutments and piers, in which event the above equation becomes of value.

The general equation including the effect of temperature changes and reaction displacements may be written

$$\Delta + \Delta_t - \Sigma r_c \Delta_r = \Sigma \frac{S s l}{AE} + \Sigma s c l \tag{22}$$

If the desired displacement Δ , is an *angular rotation* instead of a translatory movement as above, the law stated in Eq. (22) holds, the only difference being that the auxiliary unit load employed must, in this case, be a *unit moment couple*, and the stresses s must be taken as the stresses resulting from the application of this unit moment couple. (This may be easily proved from the general principles above developed; the detailed demonstration need not be given here.)

3. Work Expressions for Solid Web Beams and Cantilevers.—The fundamental principles, the demonstration of which forms the subject

matter of the foregoing articles, are based upon a consideration of framed structures. Let us now consider the case of the homogeneous beam or solid webbed structure.

Consider the structure shown in Fig. 3, a homogeneous, solid curved beam, hinged at one end and freely supported at the other, under the action of a certain system of external loading ΣF . The structure is at rest and in elastic equilibrium (see Art. 1) hence we may write

$$W_I = W_E \text{ (as in Eq. (4))}$$

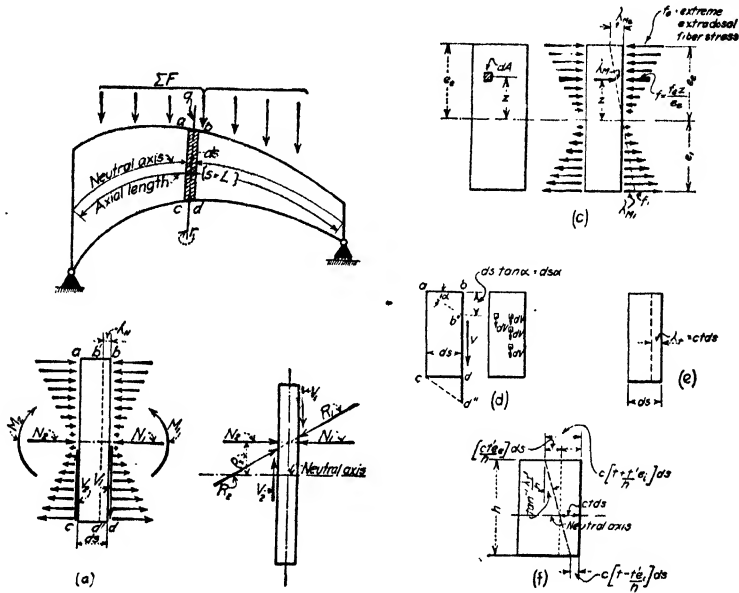

FIG. 3.

The external work is obviously represented by the expression $\frac{1}{2} \Sigma F \Delta - \frac{1}{2} \Sigma R \Delta_r$ (see Eq. (7)). The internal work corresponding to the expression $\frac{1}{2} \Sigma \frac{S^2 l}{AE}$ of Eq. (7) will now be evaluated.

Consider any lamina, $abcd$, of the beam included between two consecutive cross-sections whose distance apart is represented by the term ds (Fig. 3a).

The stresses induced in this lamina by the gradual application of the external load system ΣF may, obviously, all be resolved into two components, viz.; R_1 representing the resultant of all stresses transmitted to the lamina from that portion of the beam on the right, and R_2 representing the resultant of all those forces transmitted to the lamina from the left. Each of these forces being unknown both in direction, amount, and point of application may be represented by a normal force N applied

at the neutral axis of the section, a tangential or shearing force V , and a system of graded forces f (increasing from zero at the neutral axis to a maximum value at the extreme fibers) representing the stress couple

$$M = N\rho$$

Figure 3b shows the lamina $abcd$ as a "free body" under the action of the two resultant forces R_1 and R_2 and Fig. 3a shows these two forces resolved into the six unknown elements M_1 , M_2 , N_1 , N_2 , V_1 and V_2 .

From the figure it is apparent that

$$N_1 = N_2 \quad (23)$$

$$V_1 = V_2 \quad (24)$$

$$M_1 = M_2 + V_2 ds \quad (25)$$

Each of the three forces N , M and V cause a certain distortion of the lamina and hence the total internal work will comprise:

- (1) The work of the normal force N .
- (2) The work of the bending moment M .
- (3) The work of the shearing force V .

The derivation of the expressions for the above work elements is given in complete detail in Art. 3a. Following are the results of such derivation:

$$W_{IN} \text{ (the work of the normal force } N) = \frac{1}{2} \frac{N^2 ds}{AE} \quad (26)$$

$$W_{IM} \text{ (the work of the bending moment } M) = \frac{1}{2} \frac{M^2 ds}{EI} \quad (27)$$

$$W_{IV} \text{ (the work of the shearing forces } V) = \frac{1}{2} \frac{CV^2 ds}{E_s A} \quad (28)$$

In the above expressions:

N , V and M are as above defined.

ds is the length of the lamina of rib included between the two cross-sections $a-c$ and $b-d$.

A is the cross-sectional area of the beam.

I is the moment of inertia of the cross-section about the neutral axis (see Fig. 3).

E is the modulus of elasticity of the material in flexure.

E_s is the modulus of elasticity of the material in shear.

C is a constant depending upon the shape of the beam cross-section.

For rectangular cross-sections $C = \frac{9}{8}$

For circular cross-sections $C = \frac{10}{9}$

For I-beams and riveted plate girders C is generally taken equal to $(A_T \div A_w)$ where A_T is the total cross-section, and A_w the area of the web.

Work Due to a Uniform Change in Temperature.—For a uniform change in temperature, the only movement is a direct shortening of the lamina ds , and therefore the only force which does any work is the axial pressure N , the forces M and V doing no internal work. The total work due to a uniform temperature change is therefore

$$W_{T_1} = Nctds \quad (\text{see Art. 3a}) \quad (29)$$

Work Due to a Variable Change in Temperature.—If the upper fibers of the beam are raised or lowered to a *different* temperature than those of the lower fibers, each lamina will undergo a slight angular distortion and the moment M will undergo a certain displacement. The work of both the axial thrust N and the shearing force V are obviously zero in this case and the entire work done on the lamina is given by the expression

$$W_{T'} = \frac{Mdsct'}{h} \quad (30)$$

where t' is the difference in temperature between the upper and lower fibers of the beam and h is the total depth of the lamina.

The total work done on the lamina $abcd$ by *all* the forces active is, therefore, represented by the expression

$$W_I = \frac{N^2ds}{2AE} + \frac{M^2ds}{2EI} + \frac{CV^2ds}{2E_sA} + Nctds + \frac{Mct'ds}{h} \quad (31)$$

The entire internal work for the beam is very clearly the summation of that for each lamina.

Thus for the entire beam:

$$W_I = \frac{1}{2} \sum \frac{N^2ds}{AE} + \frac{1}{2} \sum \frac{M^2ds}{EI} + \frac{1}{2} \sum \frac{CV^2ds}{2E_sA} + \sum Nctds + \sum \frac{Mct'ds}{h} \quad (32)$$

This is the fundamental expression for the internal work in any solid homogeneous beam including temperature effects and is entirely general, holding for straight as well as for curved beams under any loading and for any method of support.

The complete work equation may therefore be written

$$\begin{aligned} \frac{1}{2} \sum F\Delta + \sum F\Delta_t + \sum F\Delta_t - \frac{1}{2} R\Delta_r &= \frac{1}{2} \sum \frac{N^2ds}{AE} + \\ &\frac{1}{2} \sum \frac{M^2ds}{EI} + \frac{1}{2} \sum \frac{CV^2ds}{2E_sA} + \sum Nctds + \sum \frac{Mct'ds}{h} \end{aligned} \quad (33)$$

This corresponds to Eq. (8) of Art. 1, except that for framed structures the effect of a variable temperature change was not considered separately.

The complete derivation of the above work formulas is given here for reference:

3a. Derivation of Expressions for Internal Work in Ribs and Beams.—

Work Due to the Axial Force N .—The effect of this force is clearly to cause the linear distortion $\lambda_N = \frac{Nds}{AE}$, where A represents the cross-sectional area of the lamina perpendicular to the line of action of the force N . If W_{IN} represents the work due to this axial force, then we may at once write

$$W_{IN} = \frac{1}{2} N \lambda_N = \frac{\frac{1}{2} N^2 ds}{AE} \quad (A)$$

Work Done by Moment Couple M .—The effect of this force is clearly, to shorten the fibers on one side of the neutral axis and lengthen them on the other, producing the distortion shown in Fig. 3c. The graded fiber stresses on the right hand face of the lamina do not exactly equal those on the left-hand face inasmuch as the two moments differ by the quantity Vds . However, by taking ds sufficiently small the average value $M = \frac{1}{2} (M_1 + M_2) = M_2 + \frac{Vds}{2}$ may be substituted for M_1 or M_2 without material error.

This average value of M represents very closely the moment along the center line $q-r$ of the lamina in question and will be designated by the letter M without subscript.

Consider any element of area dA whose distance from the neutral axis is represented by the term z (Fig. 3c).

From ordinary mechanics of flexure the stress on this element is represented by the expression

$$f dA = \frac{f_i z dA}{e_i} \quad \text{or} \quad \frac{f_i z dA}{e_i} \quad (\text{see Fig. 3c})$$

The distortion of this fiber is represented by the expression

$$\lambda_M = f \left(\frac{ds}{E} \right) = \left[\left(\frac{f_i z}{e_i} \right) \left(\frac{ds}{E} \right) \right] = \left[\left(\frac{f_i z}{e_i} \right) \left(\frac{ds}{E} \right) \right] \quad (B)$$

and the internal work resisted by this elementary area dA is represented by the expression

$$dW_{IM} = \left(\frac{1}{2} f dA \right) (\lambda_M) = \frac{\frac{1}{2} f_i^2 z^2 dA ds}{e_i^2 E} \quad (C)$$

The upper surface of a beam or arch rib is hereinafter termed the extrados and the distance to the extreme upper fiber measured from the neutral axis will be designated by the term e_s ; the extreme unit fiber stress (due to bending stresses only) will be represented by the term f_s and the corresponding extreme fiber distortion by the term λ_{Ms} . The lower surface of a beam or arch rib is hereinafter termed the intrados and the corresponding quantities will be designated by the terms e_i , f_i , λ_{Mi} , etc.

From the fundamental theory of flexure (plane sections maintained during bending) and from Hooke's law of stress and strain proportionality, it follows that, for homogenous beams and ribs

$$f_s : e_s :: f_i : e_i$$

The internal work resisted by the entire lamina is obviously given by integrating the above expression, whence

$$W_{IM} = \int_{z=-e_i}^{z=+e_s} dW_{IM} = \frac{f_s^2 ds}{2Ee_s^3} \int_{z=-e_i}^{z=+e_s} z^2 dA = \frac{f_s^2 ds I}{2Ee_s^3} \quad (D)$$

where I represents the moment of inertia of the cross-section about the neutral axis.

From the theory of flexure $\frac{f_s I}{e_s} = M$, substituting which we have

$$W_{IM} = \frac{M^2 ds}{2EI} \quad (E)$$

for the internal work overcome by the average bending moment M active on the lamina $abcd$.

Work Done by the Shearing Forces.—The effect of the shearing stress V is shown in Fig. 3d. The total shear may be considered as made up of elementary forces dV , each active on an element of area dA . The displacement of the point of application of any one of these elementary forces is, from Fig. 3d, equal to bb'' or $ds \tan \alpha$, or, since α is very small, equal to $ds \alpha$. The work resisted by each elementary force dV is therefore represented by the expression

$$dW_{IV} = \frac{1}{2}dV dA ds \alpha \tag{F}$$

But from the definition of E_s (the shearing modulus of elasticity,) $\alpha = \frac{V}{AE_s}$, whence

$$dW_{IV} = \frac{1}{2} \left(\frac{VdVdA ds}{AE_s} \right) \tag{G}$$

and the work done by the total shear V active over the entire section is represented by the expression

$$W_{IV} = \int dW_{IV} = \frac{V ds}{2AE_s} \int dV dA \tag{H}$$

If the shear were entirely vertical and uniformly distributed over the cross-section, dV would be constant and equal to $\frac{V}{A}$, whence

$$W_{IV} = \frac{V^2 ds}{2A^2 E_s} \int dA = \frac{V^2 ds}{2E_s A} \tag{I}$$

The shear is *not* uniformly distributed over the cross-section and furthermore is not exactly vertical since lateral distortions developed by the axial stresses induce small shearing stresses at right angles to the plane of the load system. Consequently the above expression must be multiplied by a distribution coefficient C which may be determined for any particular section and we may write

$$W_{IV} = \frac{CV^2 ds}{2E_s A} \tag{J}$$

The distribution coefficient is a function of the size and shape of the particular cross-section under consideration and is derived from a theoretical consideration of the distribution and direction of the elementary shearing forces active on any section. The following values of C will suffice for the solution of the problems ordinarily encountered.

For rectangular cross-sections, $C = \frac{9}{8}$.

For circular cross-sections, $C = 1\frac{1}{8}$.

For I-beams and riveted plate girders no material error will result if C is taken as

$$\frac{A_I}{A_w} = \text{total area of cross-section} \div \text{area of the web alone.}$$

Work Due to Uniform Change in Temperature.—If the lamina $abcd$ be subjected to a uniform change in temperature of t' , the force N will be displaced through a distance equal to $\lambda_t = ctds$, and the resulting work will be represented by the expression

$$W_t = Nctds \text{ (see Fig. 3e)} \tag{K}$$

The forces M and V do not in this case contribute to the internal work.

Work Due to a Variable Change in Temperature.—Assume that the temperature at the extreme lower fiber of the lamina $abcd$ exceeds that of the upper fiber by t''° and that the variation from lower to upper fiber is uniform.

In addition to the direct axial distortion (taken care of by the work expression $W_t = Nctds$ (see Eq. (K)) the lamina will distort as shown in Fig. 3f. The work at any elementary area dA whose distance from the neutral axis is z is represented by the expression

$$dW_{t'} = \left(\frac{f_s dA}{e_s} \right) \left(\frac{c' dsz}{h} \right) = \frac{f_s dsc' z^2 dA}{e_s h} \tag{L}$$

and the entire work of the lamina $abcd$ is represented by the expression

$$W_{Ii}' = \frac{f_c d s c t'}{e_c h} \int_z^{-i}^{+e} z^2 dA = \frac{f_c I d s c t'}{e_c h} = \frac{M d s c t'}{h} \quad (M)$$

Total Work on Any Lamina.—The total work done on the lamina $abcd$ by all the various forces active is represented by the expression

$$W_I = W_{IN} + W_{IM} + W_{IV} + W_{Ii} + W_{Ii}' = \frac{N^2 ds}{2AE} + \frac{M^2 ds}{2EI} + \frac{CV^2 ds}{2E_s A} + N c t ds + \frac{M c t' ds}{h} \quad (N)$$

Entire internal work for the beam is very clearly the summation of the expression given in Eq. (N) for every lamina in the beam which is obtained by integration between the limits $s = 0$ and $s = l$. Thus for the entire beam

$$W_I = \int_{s=0}^{s=l} \frac{N^2 ds}{2AE} + \int_{s=0}^{s=l} \frac{M^2 ds}{2EI} + \int_{s=0}^{s=l} \frac{CV^2 ds}{2E_s A} + \int_{s=0}^{s=l} N c t ds + \int_{s=0}^{s=l} \frac{M c t' ds}{h} \quad (O)$$

4. Displacements and Deflections in Beams and Ribs.—Proceeding exactly as in the case of the framed structure (Art. 2) we may now derive an expression for the displacement or deflection of any point in a solid beam or rib under any condition of loading.

The method of derivation is practically identical with that employed in deriving Eq. (15) of Art. 2, and need not be repeated here. The resulting equation corresponding to Eq. (15) of Art. 2 is as follows:

$$\Delta_{bc} = \sum \frac{N n_c ds}{AE} + \sum \frac{M m_c ds}{EI} + \sum \frac{CV v_c ds}{E_s A} \quad (34)$$

Where n_c , m_c and v_c represent, respectively, the axial thrust, bending moment and shear due solely to the action of a *unit auxiliary load* applied at c , acting in the direction along which the deflection Δ_{bc} is desired.

The expressions $\frac{N n_c ds}{AE}$, $\frac{M m_c ds}{EI}$ and $\frac{CV v_c ds}{E_s A}$ for any lamina will be positive when N and n_c , M and m_c , etc. have the same sign, and *vice versa*.

A positive result for the term Δ_{bc} indicates that the deflection is in the same direction as that chosen for the unit load, a negative value indicates motion in the reverse direction.

In general the displacements due to shearing strains are very small and may be neglected, whence Eq. (34) may be written

$$\Delta_{bc} = \sum \frac{N n_c ds}{AE} + \sum \frac{M m_c ds}{EI} \quad (35)$$

Throughout the remainder of this and subsequent discussions the effect of shearing distortions in ribs will be entirely ignored.

Uniform Temperature Effect.—The expression for the displacement due to a uniform change in temperature (corresponding to Eq. (17) of Art. 2) may be written

$$\Delta_{ts} = \sum n_c c t ds + \sum m_c c t ds \quad (36)$$

It is apparent from Fig. 3, that the distortion $ctds$ is an axial distortion only, the angular movement being zero. The product $(m_e)(ctds)$ is therefore zero and we may write

$$\Delta_{te} = \Sigma n_e ctds \tag{37}$$

Variable Changes in Temperature.—It is sometimes necessary to consider a condition wherein the upper and lower fibers of a beam or rib are changed to different temperatures. This condition undoubtedly obtains in masonry arches and to an even greater extent in steel ribs.

For a variable temperature change whose average value at the neutral axis is t° and whose maximum and minimum values are $t + \frac{t'e_s}{h}$ and $t - \frac{t'e_s}{h}$, Eq. (37) may be written

$$\Delta_{te} + \Delta_{t'e} = \Sigma n_e ctds + \Sigma \frac{m_e ct'ds}{h} \tag{38}$$

Where n_e acts in a direction such as to produce a strain in the same direction as $ctds$, the term $n_e ctds$ will be positive and *vice versa*. Where the moment acts in a direction such as to produce a fiber strain of the same direction as is produced by the variable temperature change t' , the term $\frac{m_e ct'ds}{h}$ will be positive and *vice versa*.

The complete equation for the displacement of any point including the effect of both variable and uniform temperature changes may now be written as follows:

$$\Delta + \Delta_t + \Delta_{t'} - \Sigma r\Delta_r = \Sigma \frac{Nnds}{AE} + \Sigma \frac{Mmds}{EI} + \Sigma n_e ctds + \Sigma \frac{m_e ct'ds}{h} \tag{39}$$

DEVELOPMENT OF THE GENERAL ELASTIC EQUATIONS FOR ARCH FRAMES OR TRUSSES

Space will not permit of a complete treatment of every problem that may arise under the general designation of fixed framed arch spans, for which reason it is doubtless well to develop first the general basic elastic equations; thereafter restricting and modifying such equations for application to the most frequently encountered problems.

The subject matter of this chapter will be devoted to a derivation of the fundamental elastic equations as follows:

General Case.—The basic elastic equation for any fixed framed arch under any load condition and for any condition of supports.

Case I.—Special case—rigid supports—temperature effects neglected.

Case II.—Special case—rigid supports—temperature effects alone considered.

Case III.—Special case—one or both arch supports elastic or yielding.

With these elastic equations developed the problem then becomes one of simplifying the same and adapting them for use under any par-

ticular set of conditions. This feature of the work forms the subject matter of succeeding chapters.

5. Redundant Forces in a Fixed Framed Arch.—Before proceeding with the derivation of the general elastic equations let us consider briefly the nature of the unknown forces present in a fixed framed arch span under any given loading.

Figure 4 is a sketch of a frame of this type, the span being taken as unsymmetrical in order to make the case perfectly general.

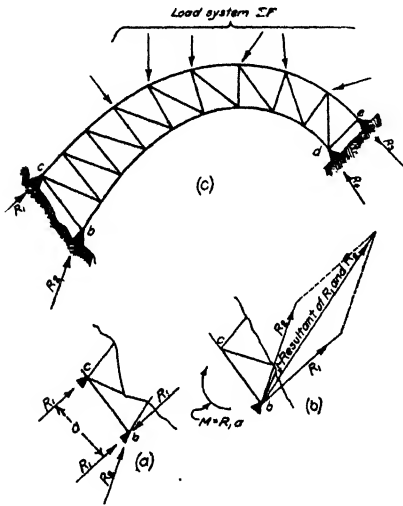

FIG. 4.

The effect of the supports may obviously be represented by four reactions R_1, R_2, R_3 and R_4 as shown, these reactions being as yet unknown both in direction and amount.

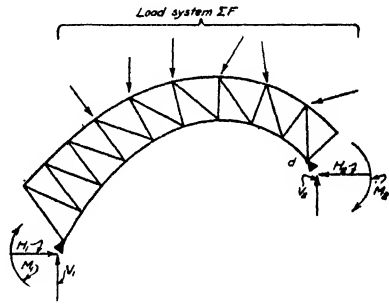

FIG. 5.

By introducing at point b (Fig. 4a) two opposing forces each equal and parallel to R_1 (which may obviously be done without disturbing the equilibrium), we may resolve R_1 and R_2 into a moment couple $M = R_1 a$ and a single inclined force (the resultant of R_1 and R_2 (Fig. 4b) both applied at point b).

Resolving this last inclined force into horizontal and vertical components and treating the right-hand abutment in a similar manner, we observe that the arch is in equilibrium under the action of the external load system and *six unknown reaction components* as follows:

At each abutment (see Fig. 5):

- (1) A horizontal force H .
- (2) A vertical force V .
- (3) A moment couple M .

There are three basic equations of static equilibrium which may be used for the determination of reaction components as follows:

$$\begin{aligned} \Sigma(\text{Horizontal forces or components}) &= 0 \\ \Sigma(\text{Vertical forces or components}) &= 0 \\ \Sigma(\text{Moments about any point}) &= 0 \end{aligned}$$

These equations suffice for the determination of three of the above six reaction components, leaving three unknown forces which cannot be evaluated by statics.

These forces are known as "statically indeterminate" forces or reaction components and must be determined by means of the elastic equations hereinafter developed.

These forces are also sometimes termed "redundant" forces the name being derived from the fact that such forces are not necessary to the stability of the structure.

To illustrate this last point the three forces H , V and M , at the left support could be entirely removed and the structure would still be stable as a cantilever and if properly designed would still carry a load (see Fig. 6). If, in addition, however, either of the forces R_3 or R_4 (or what amounts to the same thing either of the forces H_2 , V_2 or M_2) were to be removed, the structure would immediately collapse regardless of the size of the members.

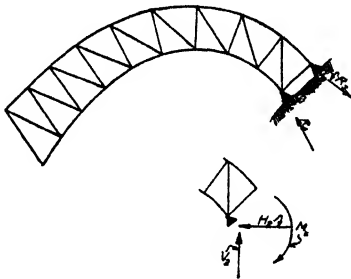

FIG. 6.

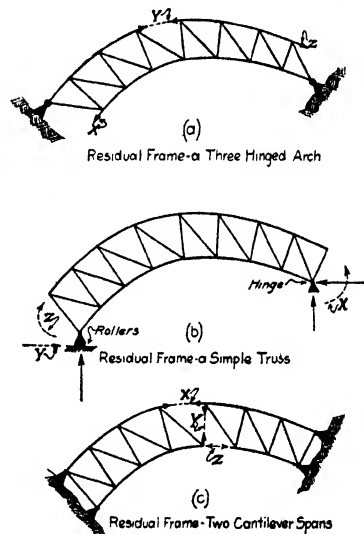

FIG. 7.

Statically indeterminate forces or reaction components are always redundant in the above sense. Such reactions are supplied for economy and rigidity but not necessarily for stability.

6. Residual Frames.—From the foregoing it is apparent that the statically indeterminate forces or reaction components can always be removed, leaving a statically determinate frame which is stable under load but of greatly decreased strength.

The frame resulting from the removal of such redundant forces will be designated the "residual frame."

Residual frames for framed arch construction may be developed in several different ways. For example:

(1) The three reactions at either support may be removed, developing a cantilever residual frame (Fig. 6).

(2) The three members as shown in Fig. 7a may be removed and the residual frame becomes a three-hinged arch.

(3) One horizontal reaction component and both reaction moment couples may be removed and the residual frame becomes a simple truss span (Fig. 7b).

(4) Three members near the crown may be removed leaving the residual frame as two cantilever spans (Fig. 7c).

The first method apparently results in a residual frame which is simple and easy to analyze and will be the method used hereinafter.

In general the redundants should be chosen so as to develop the simplest residual frame. For arch analysis the removal of the three reaction components at either end is the procedure generally followed although some methods of analysis are based upon the removal of three members at the crown, leaving the residual frame as two simple cantilevers. This last method has some advantages in the case of symmetrical arches.

7. Properties of the Residual Frame.—Consider the fixed arch span of Fig. 8. If the support at point b were to be removed, the structure would

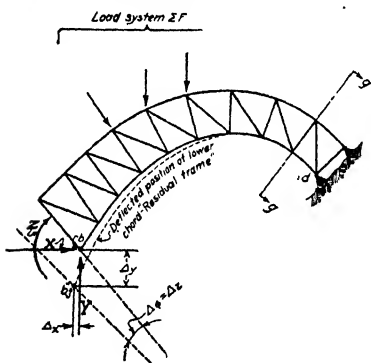

FIG. 8.

be at once transformed into a cantilever span fixed at the right support. It is apparent that the removal of this support greatly modifies the values of the internal stresses, the remaining support reactions and the deflection of the span, for any given loading ΣF . If, however, at this left support there be inserted three unknown forces as follows:

X = the unknown horizontal component
 Y = the unknown vertical component
 Z = an unknown moment couple

and if these three forces be given such value (as yet unknown) that the same will *exactly reproduce the effect of the removed support*, then the original stresses, support reactions, etc., remain unchanged. In other words, the stresses in any member of the original arch, under the given loading ΣF , is equal to the stress in this same member of the residual cantilever under the action of the given loading, plus three forces X , Y and Z , having some certain value as yet unknown and applied as shown (see Fig. 8). (This is in accordance with the law stated in elementary mechanics that any member of a frame may be removed without disturbing the equilibrium, *provided a force or forces representing the complete action of this member or the rest of the structure be inserted in its place.*)

It is also observed that the unknown redundant forces must be such as to hold the residual cantilever *in exactly the same position under any given load system as that which the original arch would take*, since the

stresses and consequently the distortions remain unchanged. In other words, the removal of the left support would cause the point b (for example) of the residual cantilever, to deflect to some point b'' , but the three forces X , Y , and Z are, by hypothesis, just sufficient to bring the frame back to its original position.

Let:

S = total stress in any member of the original arch, due to whatever cause.

S_o = stress in any member of the residual cantilever resulting from the given external loadings only (all redundant conditions removed).

S_x = stress in any member of the residual cantilever due solely to the redundant condition X (all other loads being removed).

S_y = stress in any member of the residual cantilever due solely to the redundant condition Y (all other loads being removed).

S_z = stress in any member of the residual cantilever due solely to the redundant condition Z (all other loads being removed).

s_x = stress in any member of the residual cantilever due solely to a unit load applied at b and acting along the line of action of the redundant X (all other loads being removed).

s_y = similar stress due solely to a unit load applied at b but acting along the line of action of the redundant Y (all other loads being removed).

s_z = similar stress due solely to the action of a unit moment couple applied at b and in the direction assumed for Z (all other loads being removed).

All tensile stresses are considered positive in sign; all compressive stresses negative.

From the foregoing discussion, it is apparent that we may at once write:

$$S = S_o + S_x + S_y + S_z \tag{40}$$

Also, since the stress in any member of the residual frame is a linear function of its inducing load,

$$\left. \begin{aligned} S_x &= Xs_x \\ S_y &= Ys_y \\ S_z &= Zs_z \end{aligned} \right\} \tag{41}$$

Whence

$$S = S_o + Xs_x + Ys_y + Zs_z \tag{42}$$

As before stated, the stresses in the residual frame are not altered by the removal of the supports at b , and the insertion of the equivalent unknown forces X and Y and Z , from which it is apparent that the deflection of any point in the original structure may be determined by applying Eq. (22) to the residual frame, using the values

$$S = S_o + Xs_x + Ys_y + Zs_z$$

8. Development of the General Elastic Equations.—Substituting for S from Eq. (42), we may write Eq. (22) for the arch span shown in Fig. 8 as follows:

$$\Delta_x + \Delta_{tx} - \Sigma r_x \Delta_r = \Sigma (S_o + X s_x + Y s_y + Z s_z) \frac{s_x l}{AE} + \Sigma s_x c t l$$

which represents the total displacement of the redundant X .

Writing a similar expression for the displacement of the redundants Y and Z , we derive the following three basic equations:

$$\Delta_x + \Delta_{tx} - \Sigma r_x \Delta_r = \Sigma \frac{S_o s_x l}{AE} + X \Sigma \frac{s_x^2 l}{AE} + Y \Sigma \frac{s_x s_y l}{AE} + Z \Sigma \frac{s_x s_z l}{AE} + \Sigma s_x c t l. \quad (43)$$

$$\Delta_y + \Delta_{ty} - \Sigma r_y \Delta_r = \Sigma \frac{S_o s_y l}{AE} + X \Sigma \frac{s_x s_y l}{AE} + Y \Sigma \frac{s_y^2 l}{AE} + Z \Sigma \frac{s_y s_z l}{AE} + \Sigma s_y c t l. \quad (44)$$

$$\Delta_z + \Delta_{tz} - \Sigma r_z \Delta_r = \Sigma \frac{S_o s_z l}{AE} + X \Sigma \frac{s_x s_z l}{AE} + Y \Sigma \frac{s_y s_z l}{AE} + Z \Sigma \frac{s_z^2 l}{AE} + \Sigma s_z c t l. \quad (45)$$

In the above equations the following definition of terms and signs must be observed:

Δ_x, Δ_y , etc. are the displacements of the point of application of the given redundant force measured in the direction in which such force is assumed to act with respect to the rest of the frame.

Δ_{tx}, Δ_{ty} , etc. represent similar displacements but refer to temperature effects. This displacement must also be measured in the direction of action assumed for the redundant forces X, Y , etc.

$-\Sigma r_x \Delta_r, -\Sigma r_y \Delta_r$, etc. represent summations extending over the residual frame not the original structure. The terms Δ_r are measured in the direction opposite that of the corresponding reactions r_x or r_y .

The minus sign before the above summation sign indicates that the work of an elastic support is always negative.

The individual terms $S_o s_x, s_y s_x, s_z s_x$, etc. under the various summation signs are positive or negative according as the two terms carry like or unlike signs. For a rise in temperature the individual terms $s_x c t l$ are positive for tensile stresses, and negative for compressive stresses and *vice versa*.

The above equations are applicable to any fixed framed arch span under any condition of loading and any condition as regards rigidity of

supports. They are, however, more or less unwieldy and can be somewhat simplified for use in certain particular cases as follows:

Case I—Rigid Supports, Temperature Changes Neglected.—In this case, since the supports on the residual frame are rigid

$$\left. \begin{aligned} \sum r_x \Delta_r &= 0 \\ \sum r_y \Delta_r &= 0 \\ \sum r_z \Delta_r &= 0 \end{aligned} \right\} \quad (46)$$

Since the supports on the arch span at the left end are also assumed as rigid, the displacement of the redundant forces must also be zero, that is to say:

$$\left. \begin{aligned} \Delta_x &= 0 \\ \Delta_y &= 0 \\ \Delta_z &= 0 \end{aligned} \right\} \quad (47)$$

Therefore neglecting temperature terms we may write

$$\sum \frac{S_o s_x l}{AE} + X \sum \frac{s_x^2 l}{AE} + Y \sum \frac{s_x s_y l}{AE} + Z \sum \frac{s_x s_z l}{AE} = 0 \quad (48)$$

$$\sum \frac{S_o s_y l}{AE} + X \sum \frac{s_x s_y l}{AE} + Y \sum \frac{s_y^2 l}{AE} + Z \sum \frac{s_y s_z l}{AE} = 0 \quad (49)$$

$$\sum \frac{S_o s_z l}{AE} + X \sum \frac{s_x s_z l}{AE} + Y \sum \frac{s_y s_z l}{AE} + Z \sum \frac{s_z^2 l}{AE} = 0 \quad (50)$$

All the terms in the above three equations, except X , Y and Z , are easily found, being stresses, lengths, etc. for the residual cantilever which is statically determinate.

After these terms are computed, the three equations can easily be solved for X , Y and Z .

Having X , Y and Z , the stresses "S" in the arch frame are obtained from Eq. (42).

The value of any support reaction at the right-hand support, such for example as H , is obviously given by the equation

$$H = H_o + Xh_x + Yh_y + Zh_z \quad (51)$$

where H_o is the value of the horizontal thrust at point d for the residual cantilever under the given load system, and h_x , h_y , and h_z , are values of this horizontal thrust due solely to unit loads applied at b along the line of action of X , Y , and Z respectively (these thrusts being obviously computed for the residual cantilever).

In a similar manner M_{g-g} , the bending moment in the arch frame about any line $g-g$, is given by the expression

$$M = M_o + Xm_x + Ym_y + Zm_z \quad (52)$$

Particular attention must be paid to the signs of H_o , M_o , m_x , m_y , X , Y , etc.

Case II—Temperature Stresses (Rigid Supports).—The effect of temperature stresses alone may be readily obtained by writing Eqs. (43), (44)

and (45) with the stress S_0 placed equal to zero. Also as in Case I since the supports are rigid and unyielding the entire left-hand member of each of the above equations may also be made to vanish, whence we have:

$$X \sum \frac{s_x^2 l}{AE} + Y \sum \frac{s_x s_y l}{AE} + Z \sum \frac{s_x s_z l}{AE} + \Sigma s_x c t l = 0 \tag{53}$$

$$X \sum \frac{s_x s_y l}{AE} + Y \sum \frac{s_y^2 l}{AE} + Z \sum \frac{s_y s_z l}{AE} + \Sigma s_y c t l = 0 \tag{54}$$

$$X \sum \frac{s_x s_z l}{AE} + Y \sum \frac{s_y s_z l}{AE} + Z \sum \frac{s_z^2 l}{AE} + \Sigma s_z c t l = 0 \tag{55}$$

The individual terms $s_x c t l$, $s_y c t l$ and $s_z c t l$ under the summation sign will be positive or negative according as s and $c t l$ are of equal or opposite direction. For a rise in temperature $c t l$ will carry the same sign as a tensile stress and *vice versa*.

Case III—One or Both Supports Elastic or Yielding.—This is a condition which rarely occurs in practice, particularly in the case of framed arches which are chosen in general only for long spans and for locations where natural foundations are of the best. The equations for this case are of course adapted from the general elastic equations [Eqs. (43), (44) and (45)] but the process is rather long and the discussion more or less involved.

For the foregoing reasons the entire question of elastic and yielding supports will be reserved for discussion elsewhere.

ELASTIC INFLUENCE LINES FOR FIXED FRAMED ARCHES

Having developed, in the preceding chapter, the fundamental elastic equations for the analysis of stresses in this type of structure, the present chapter will be devoted to a consideration of methods whereby these formulas may be simplified for more ready application to the analysis proper.

9. Simplification of Elastic Equations.—Consider the arch span of Fig. 9, under the action of any external load system ΣF . It has been shown in the preceding chapter that the removal of the left support and the insertion of three redundant reaction components (two linear forces and one moment couple) at point b , so proportioned as to reproduce the action of the removed support does not disturb the equilibrium nor modify the stresses in the arch frame. Let us carry this one step further

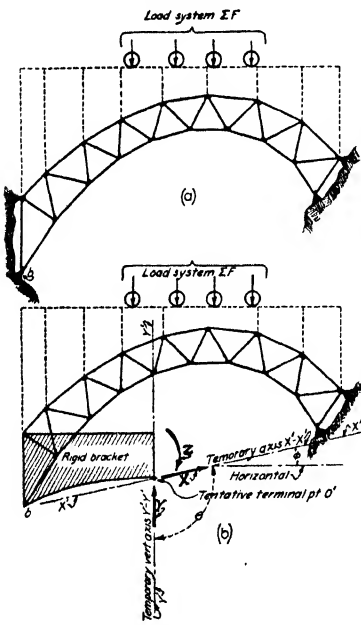

FIG. 9.

and replace the left support by a rigid bracket as shown in Fig. 9b, terminating at some point O' .

If this rigid bracket is acted upon by two linear forces X and Y and a moment couple Z , it is apparent that these new redundant forces may be so proportioned as to exactly reproduce the effect of the first three redundants (applied at point b). We may therefore solve, for the forces X , Y and Z applied at the terminal point of the rigid bracket, by means of Eqs. (48) to (50) and (53 to 55) *exactly as before*. The results will not be identical with values obtained by placing the redundants at point b , but their combined effect will be identical as regards the stress in any member of the frame.

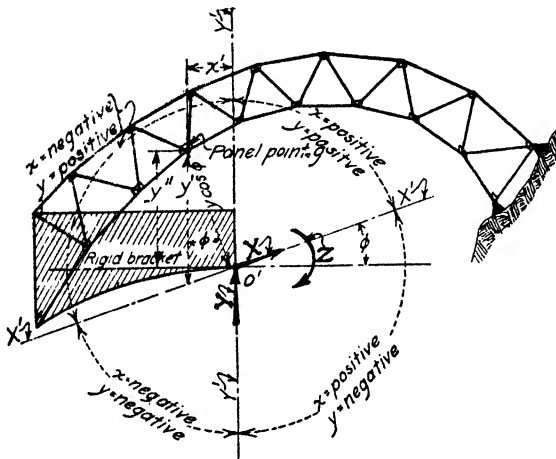

FIG. 10.

It will now be shown that by properly locating the terminal point O of the above bracket and by properly selecting the angle θ between the lines of action of the two redundants X and Y , the resulting elastic equations may be very much simplified.

Referring again to Fig. 9, let us assume the redundant Y to act vertically upward, the redundant X to act upward and to the right making some angle θ with the line of action of Y and an angle of $\phi = (\theta - 90 \text{ deg.})$ with the horizontal. The direction of the redundant moment Z will be assumed as shown in the figure. (As has already been pointed out the direction of action of the redundant forces may always be arbitrarily assumed. If these directions are reversed under any given loading the values of the redundants under such loading will simply come out negative.)

Through the assumed terminal point O' construct two temporary coordinate axes $X'X'$ parallel to the line of action of the redundant X , and $Y'Y'$ parallel to the line of action of the redundant Y .

Let x' represent the abscissa of any panel point (or moment center, such as g Fig. 10) measured *horizontally* from the axes $Y'Y'$.

Let y' represent the ordinate of any panel point (or moment center) measured *vertically* from the axes $X'X'$.

For each member of the frame compute the term $G = \left[\frac{s_z l}{AE\rho} \right]$, where

s_z = the stress in this member of the residual cantilever due solely to the unit auxiliary load (moment couple) $Z = \text{unity}$.

l , A and E = as previously defined.

ρ = the perpendicular dropped on the member in question from the center of moments for that member (see Fig. 11).

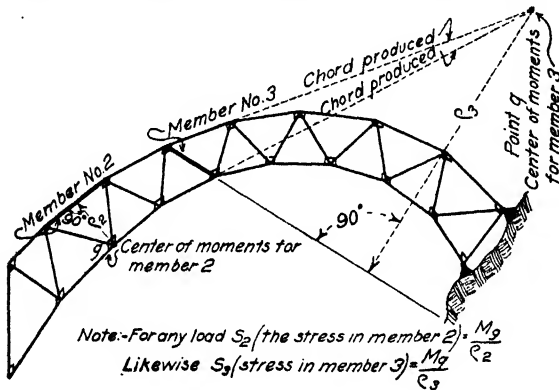

FIG. 11.

The values G will be termed the *elastic weights* of the members in question and are hereinafter considered as loads.

Also let:

m_x = the moment at any panel point (or moment center) due to an auxiliary unit load applied at O' along the line of action of the redundant X and acting in the same direction.

m_y = the moment at any panel point (or moment center) due solely to an auxiliary unit load applied at O' along the line of action of Y and acting in the same direction.

m_z = the moment at any panel point (or moment center) due solely to an auxiliary unit moment couple applied at O' and acting in the direction assumed for Z . The moments m_x , m_z and m_y obviously refer to the residual cantilever not the fixed arch.

(Moments which produce compressive stresses in the top chord of the residual cantilever will be designated as positive and *vice versa*. The coordinate x' will be designated as positive to the right and negative to the left of the $Y'Y'$ axis, the coordinate y' as positive above and negative below the axis $X'X'$.)

Then from the above and from Fig. 11 (paying due attention to the sign designations and to the direction assumed for the redundant forces)

$$m_x = 1.0 \tag{56}$$

$$m_x = -y' \cos \phi = -(y'' - x \tan \phi) \cos \phi \tag{57}$$

where y'' is the vertical ordinate measured from a horizontal axis through the origin O'

$$m_y = x' \tag{58}$$

$$s_x = \frac{1}{\rho} \tag{59}$$

$$s_x = -\frac{y' \cos \phi}{\rho} \tag{60}$$

$$s_y = \frac{x'}{\rho} \tag{61}$$

Therefore (since $G = \frac{s_x l}{AE\rho} = \frac{l}{AE\rho^2}$)

$$\sum \frac{s_x s_x l}{AE} = -\Sigma G y' \cos \phi = -\cos \phi \Sigma G y' \tag{62}$$

$$\sum \frac{s_x s_y l}{AE} = \Sigma G x' \tag{63}$$

Now if the center of gravity of the "elastic load" system ΣG be determined and the terminal point of the rigid bracket be shifted to such point, we may, at once, write

$$\Sigma G y' = 0 \tag{64}$$

$$\Sigma G x' = 0 \tag{65}$$

whence $\sum \frac{s_x s_x l}{AE}$ and $\sum \frac{s_x s_y l}{AE}$ both vanish from the elastic equations.

The above required center of gravity (which will hereinafter be termed the "elastic center" of the arch system) is obviously located either by means of graphics or algebraically, as shown in Fig. 12, in exactly the same manner as for any ordinary load system.

For example, in Fig. 12 the "elastic weights" have been applied

(1) Vertically, whence $\bar{x} = \frac{\Sigma G x'}{\Sigma G}$

(2) Horizontally, whence $\bar{y}'' = \frac{\Sigma G y''}{\Sigma G}$

(3) (as a check) Parallel to $X-X$, whence $\overline{y \cos \phi} = \frac{\Sigma G y' \cos \phi}{\Sigma G}$

If the work is done correctly, the three "elastic resultants" will intersect in a point which is the required "elastic center."

The terminal point for the rigid bracket is now shifted to the true elastic center, whence (see Fig. 12)

$$x = x' - \bar{x} \tag{66}$$

$$y = y' - \bar{y} \tag{67}$$

Thus far the angle ϕ has not been determined and our next step is the evaluation of this angle, such that

$$\sum \frac{s_x s_y l}{AE} = 0$$

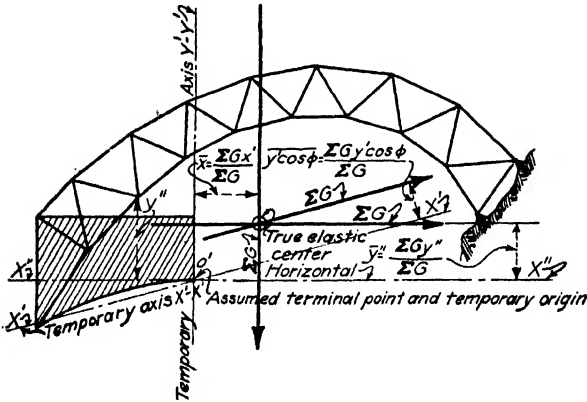

FIG. 12.

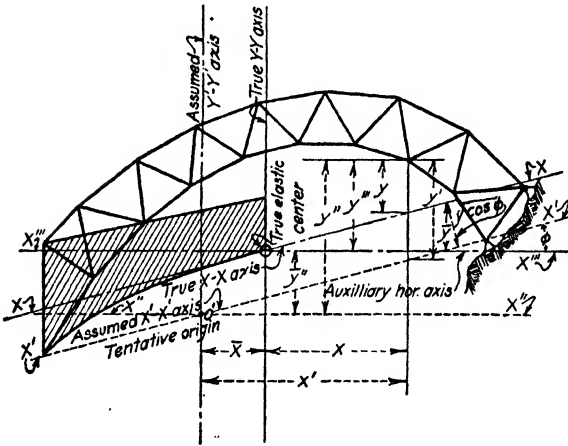

FIG. 13.

To do this proceed as follows: Through the true elastic center as above located construct an auxiliary *horizontal* coordinate axis $X'''-X'''$, and determine the *vertical* ordinates y''' for each panel point or moment center (see Fig. 13). Obviously

$$\begin{aligned} y &= y''' - x \tan \phi \\ &= (y'' - \bar{y}') - (x' - \bar{x}) \tan \phi \end{aligned} \tag{68}$$

Also

$$s_x = -\frac{1}{\rho}(y \cos \phi) = -\frac{1}{\rho} \cos \phi [(y'' - \bar{y}'') - (x' - \bar{x}) \tan \phi] \quad (69)$$

$$s_y = \frac{1}{\rho}(x) = \frac{1}{\rho}(x' - \bar{x}) \quad (70)$$

Placing $\sum \frac{s_x s_y l}{AE} = 0$ gives the following:

$$-\sum \frac{l}{AE \rho^2} \cos \phi [(y'' - \bar{y}'')(x' - \bar{x}) - (x' - \bar{x})^2 \tan \phi] = 0 \quad (71)$$

or

$$\Sigma G x y'' \cos \phi - \Sigma G x' \bar{y}'' \cos \phi - \Sigma G \bar{x} y'' \cos \phi + \Sigma G \bar{x} \bar{y}'' \cos \phi - \Sigma G (x' - \bar{x})^2 \sin \phi = 0 \quad (72)$$

or

$$\tan \phi = \frac{\Sigma G x' y'' - \Sigma G x' \bar{y}'' - \Sigma G \bar{x} y'' + \Sigma G \bar{x} \bar{y}''}{\Sigma G (x' - \bar{x})^2} \quad (73)$$

From the above equation the angle ϕ is readily found.

With the redundant X making the above determined angle ϕ with the horizontal and with the rigid bracket terminating at the elastic center, it has been shown that

$$\left. \begin{aligned} \sum \frac{s_x s_y l}{AE} \\ \sum \frac{s_x s_x l}{AE} \\ \sum \frac{s_y s_x l}{AE} \end{aligned} \right\} \text{all vanish}$$

Whence Eqs. (48) to (50) may be written:

$$X = - \left[\frac{\sum \frac{S_o s_x l}{AE}}{\sum \frac{(s_x)^2 l}{AE}} \right] \quad (74)$$

$$Y = - \left[\frac{\sum \frac{S_o s_y l}{AE}}{\sum \frac{(s_y)^2 l}{AE}} \right] \quad (75)$$

$$Z = - \left[\frac{\sum \frac{S_o s_x l}{AE}}{\sum \frac{(s_x)^2 l}{AE}} \right] \quad (76)$$

Also, for temperature stresses, Eqs. (53) to (55) become

$$X_t = - \frac{\left[\frac{\sum s_x c t l}{\sum \frac{(s_x)^2 l}{A E}} \right]}{\quad} \quad (77)$$

$$Y_t = - \frac{\left[\frac{\sum s_y c t l}{\sum \frac{(s_y)^2 l}{A E}} \right]}{\quad} \quad (78)$$

$$Z_t = - \frac{\left[\frac{\sum s_z c t l}{\sum \frac{(s_z)^2 l}{A E}} \right]}{\quad} \quad (79)$$

10. Application of Above Simplified Formulas.—Equations (74) to (76) may be solved algebraically for any given condition of external loading but this process is rather laborious inasmuch as it requires a substitution in the formulas for every different possible combination of live and dead loads.

A much more expeditious method of analysis may be developed by the construction of influence lines for the three redundants X , Y and Z .

The method and underlying theory is as follows: The effect of the web distortions in framed arch structures is very slight. Moreover the inclusion of web strains, in general, results in a large number of elastic weights and rather complex graphical diagrams. For this reason it is general practice to ignore the web system when developing the influence lines for the redundant reaction components. This will be done in this case, the method wherein web strains are included being considered in the appendix which follows this chapter.

Gravity Loadings.—For a unit load at any point, say point g (Fig. 14), S_o becomes s_{og} and Eqs. (74) to (76) may be written:

$$X_g = - \frac{\left[\frac{\sum \frac{s_{og} s_x l}{A E}}{\sum \frac{(s_x)^2 l}{A E}} \right]}{\quad} \quad (80)$$

$$Y_g = - \frac{\left[\frac{\sum \frac{s_{og} s_y l}{A E}}{\sum \frac{(s_y)^2 l}{A E}} \right]}{\quad} \quad (81)$$

$$Z_g = - \frac{\left[\frac{\sum \frac{s_{og} s_z l}{A E}}{\sum \frac{(s_z)^2 l}{A E}} \right]}{\quad} \quad (82)$$

With these unit load formulas we may proceed as follows:

- (1) Reverse the supports on the residual cantilever thus considering it as fixed at the left support and free at the right (see Fig. 14).
- (2) Construct a load line with the elastic weights G applied at their corresponding panel points.
- (3) With a pole distance equal to ΣG construct a ray diagram and equilibrium polygon for the cantilever fixed at the left support.

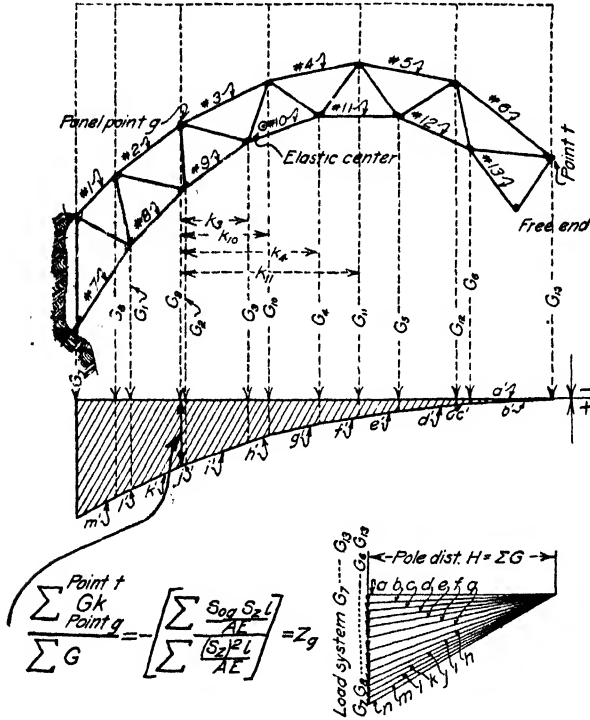

"Reversed" Cantilever

FIG. 14.—Influence line for redundant Z .

Result:

This equilibrium polygon is the influence line for the redundant Z .

Proof:

Any intercept through any panel point, as for example panel point g (see Fig. 14), measures the term

$$\sum_{Point a}^{\text{Point } t} \frac{Gk}{H} = \frac{\sum_a^t Gk}{\sum G} = \frac{\sum \left(\frac{s_z l}{AE} \right) \left(\frac{k}{\rho} \right)}{\sum \frac{(s_z)^2 l}{AE}} \tag{83}$$

From Fig. 15 we at once observe that

$$s_{og} = -\frac{k}{\rho}$$

Whence

$$-\sum \frac{k}{\rho} = \sum s_{og} \tag{84}$$

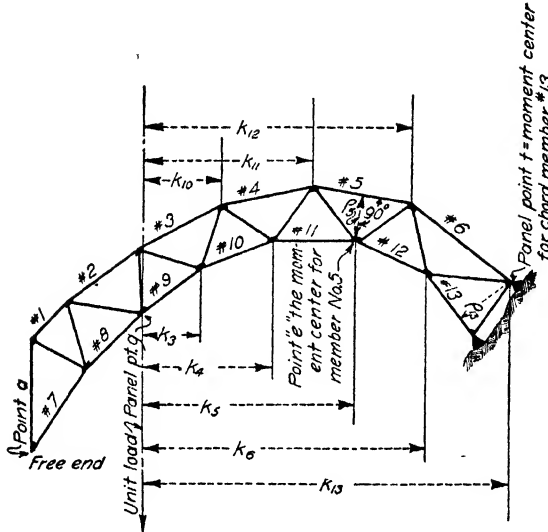

Note:- For cantilever as shown (fixed at right end) s_{og} (the stress in any member due to a unit load at g) is equal to m_{og}/ρ (the moment at the center of moments for this member due to the same loading divided by ρ the perpendicular dropped onto the member from said moment center).

Therefore for a unit load at g $m_{og} = -k$
 $s_{og} = -k/\rho$
 and $\sum s_{og} = -\sum_{\text{Point } g}^{Point t} \frac{k}{\rho} + \sum_{\text{Point } a}^{Point o} \frac{k}{\rho}$

FIG. 15.

Therefore this intercept measures the term

$$-\left[\frac{\sum \frac{s_{og} s_z l}{AE}}{\sum \frac{(s_z)^2 l}{AE}} \right] = Z_o \tag{85}$$

¹The negative sign is used because the moment $\frac{k}{\rho}$ produces tension in the top chord members of the residual cantilever.

In a similar manner if the load system ΣGx be employed and an equilibrium polygon constructed, using a pole distance $H = \Sigma Gx^2$, the intercept vertically through any panel point g measures the value

$$\sum_0^t \frac{Gxk}{H} = \frac{\sum_0^t Gxk}{\sum Gx^2} = \frac{\sum_0^t \left(\frac{k}{\rho}\right) \left(\frac{x}{\rho}\right) \frac{l}{AE}}{\sum \left(\frac{x}{\rho}\right)^2 \frac{l}{AE}} \tag{86}$$

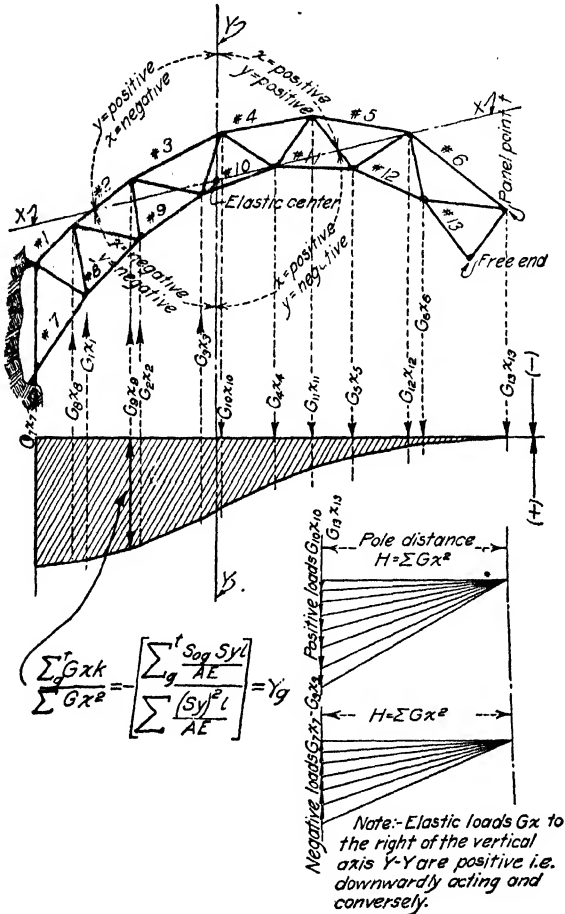

FIG. 16.

As before

$$-\frac{k}{\rho} = s_{00} \tag{87}$$

$$\frac{x}{\rho} = s_y \tag{88}$$

Therefore this ordinate measures the term

$$-\left[\frac{\sum \frac{s_{og} s_y l}{AE}}{\sum \frac{(s_y)^2 l}{AE}} \right] = Y_o \tag{89}$$

This equilibrium polygon is therefore the influence line for the redundant Y (see Fig. 16).

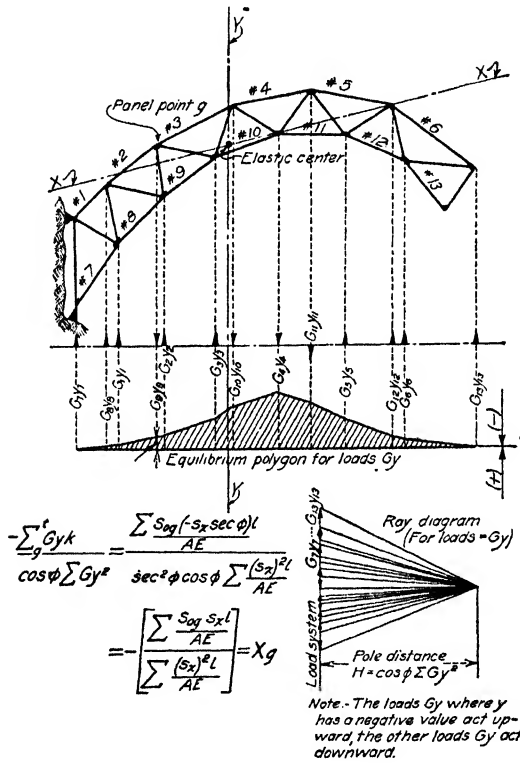

FIG. 17.

The influence line for the redundant X is constructed in a similar manner. In this case:

Load system = ΣG_y

Pole distance = $\Sigma G_y^2 \cos \phi = \cos \phi \Sigma G_y^2$

Obviously the vertical intercept through panel point g measures the term

$$\frac{-\sum_o^i G_y k}{H} = \frac{-\sum_o^i G_y k}{\cos \phi \sum G_y^2} = -\left[\frac{\sum_o^i \left(\frac{k}{\rho}\right) \left(\frac{l}{AE}\right) \left(\frac{y}{\rho}\right)}{\cos \phi \sum \frac{l}{AE} \left(\frac{y}{\rho}\right)^2} \right] \tag{90}$$

As before

$$\frac{-k}{\rho} = s_{og} \tag{91}$$

Also

$$\frac{y}{\rho} = -s_x(\sec \phi) \tag{92}$$

Whence this intercept may be written (see Fig. 17)

$$\frac{-(\sec \phi) \sum \frac{s_{og}s_x l}{AE}}{(\sec \phi)^2(\cos \phi) \sum \frac{(s_x)^2 l}{AE}} = - \left[\frac{\sum \frac{s_{og}s_x l}{AE}}{\sum \frac{(s_x)^2 l}{AE}} \right] = X_g \tag{93}$$

Having the above influence lines determined, the redundant reaction components are readily obtained for any given system of external loading (dead or live) and, having these redundants, the stresses, reactions, displacements, etc., for any point or member of the arch frame are readily determined from statics (see next chapter).

Temperature Stresses (Uniform Change).—The value of the redundant reaction components induced by a uniform change in temperature may be determined directly from Eqs. (77) to (79) as follows:

For a uniform change of t° in each member of the span

$$X_t = - \left[\frac{\sum s_x c t l}{(\cos \phi)^2 \sum G y^2} \right] = \frac{\sum \left(\frac{y}{\rho} \right) c t l}{\cos \phi \sum G y^2} \tag{94}$$

$$Y_t = - \left[\frac{s_y c t l}{\sum G x^2} \right] = - \frac{\sum \left(\frac{x}{\rho} \right) c t l}{\sum G x^2} \tag{95}$$

$$Z_t = - \left[\frac{s_z c t l}{\sum G} \right] = - \frac{\sum \left(\frac{1}{\rho} \right) c t l}{\sum G} \tag{96}$$

The individual terms under the summation sign will be positive for a temperature rise and negative for a temperature drop, when s_x , s_y and s_z represent *tensile* stresses and *vice versa*.

Stresses Due to a Variable Change in Temperature.—If the change in internal temperature is different for different members of the span, the above formulas may still be used, the only difference being that the value of t will be different for the different members occurring in the summations $\sum s_x c t l$, $\sum s_y c t l$, etc.

11. Horizontal and Inclined Loads.—Equations (74) to (76) hold for stresses produced by any system of external loading—horizontal, vertical or inclined. The influence lines developed in Art. 10, however, are based upon the consideration of a moving unit *vertical* load. If the effect of a system of inclined loads is desired, it is quite possible to develop a system of influence lines for the same, but whether this method of procedure has anything to recommend it over the direct solution of Eqs. (74) to (76) depends wholly upon the conditions of the problem. The utility of a series of influence lines constructed for a unit horizontal moving load is not such as to warrant discussion at this point.

12. Direction of the Redundant Forces.—The result of the demonstration which forms the subject matter of Arts. 9 and 10 indicates that the redundant forces X , Y and Z each act in the direction first assumed (see Fig. 9a) for any position of the moving vertical load. If the assumed direction of one or more of these forces were to be reversed, the signs of the corresponding terms m_x , m_y or m_z , as the case may be, would be immediately reversed and the expression for the redundants in question would come out negative indicating a direction of action as first assumed.

Effect of Web Distortions.—As stated hereinabove the effect of web distortions in this type of structure is relatively slight and is usually neglected in the determination of influence lines for the redundant reaction components.

The effect of these distortions corresponds in a general way to that of the shearing strains in a solid homogeneous beam, although the former are rather more pronounced because of the smaller relative area of the web system.

It is generally possible (except for parallel chord arch frames) to include the effect of web strains by employing, for each web member, a single elastic load applied at the center of moments (intersection of chords) for such web member (see Fig. 11). These loads are, however, inconvenient to handle, oftentimes falling entirely outside the limits of the drawing. The following method, using for each web member a pair of loads, opposite in direction, is much more convenient. The demonstration is as follows:

Elastic Loads for Web Strains.—Consider the elastic load $G_3 = \left(\frac{s_3 l}{AE\rho_3} \right)$ applied at the center of moments for web member No. 3 (Fig. 18). It is possible to exactly reproduce the effect of this elastic load (applied at O_3) by two elastic loads

$$G_3'' = G_3 \left(\frac{a+d}{d} \right) \text{ applied at point } f$$

and

$$G_3' = -G_3 \left(\frac{a}{d} \right) \text{ applied at point } e$$

as shown in Fig. 18. These two elastic loads applied at points f and e may therefore be substituted for the original load G_3 applied at O_3 .

Plotting a ray diagram with pole distance $H = \Sigma G$ and a corresponding equilibrium polygon for these *substitute elastic loads*, applied to the *reversed cantilever* (fixed at left support), the vertical intercept under point f obviously measures the term

$$\frac{G_3' d}{\Sigma G} = \frac{-G_3 a}{\Sigma G}$$

The intercept under point d is measured by the term

$$\frac{G_3 d \left(\frac{b}{a}\right)}{\Sigma G} = \frac{-G_3 b}{\Sigma G}$$

Now from Eq. (76) the effect of this web member on the Z influence line is represented by the term

$$dZ_3 = - \left[\frac{\frac{s_{o3}s_{e3}d}{AE}}{\sum \frac{(s_x)^2 l}{AE}} \right] = \frac{-s_{o3}G_3 \rho}{\Sigma G}$$

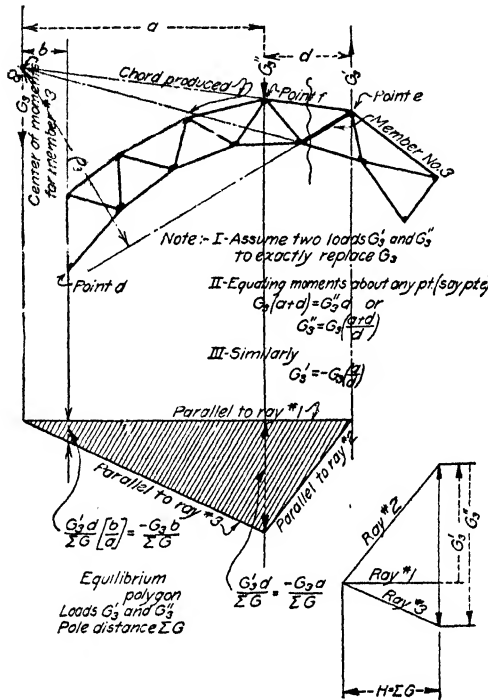

FIG. 18.

For a unit load at point f

$$s_{o3} = \frac{a}{\rho}$$

and by substitution

$$dZ_3 = \frac{-G_3 a}{\Sigma G}$$

Similarly for a load at point d

$$s_{o3} = \frac{b}{\rho}$$

and

$$dZ_3 = \frac{-G_3 b}{\Sigma G}$$

The equilibrium polygon for the two elastic loads G_3' and G_3'' applied to the "reversed cantilever" using a pole distance $H = \Sigma G$ is therefore identical with the influence line representing the effect of the web member No. 3 on the redundant Z . We have only, therefore, to add the two elastic loads G_3' and G_3'' (acting as shown) to the elastic load line of Fig. 14 in order to include the effect of this web member.

In a manner similar to the above the two loads G_3' and G_3'' may be shown to exactly replace the single load G_3 when using the load system G_x or G_y . The above identity may also be proved for any web member.

When the chords are parallel, the lever arms a and b of Fig. 18 become infinite and the expressions representing the value dZ involve the indeterminates $(0 \cdot \infty)$.

Some other method of evaluating the same must therefore be devised. This may be accomplished as follows: Suppose the two chords whose intersection determines the moment center O_3 for web member No. 3 (Fig. 18) to be parallel. The position of O_3 therefore recedes to infinity and rays No. 1 and No. 3 become parallel (see Fig. 19).

The two elastic loads G_3' and G_3'' must therefore be equal and opposite and may be evaluated as follows: Place a single unit load at point f and determine the resulting stress s_{f3} in web member No. 3 (either algebraically or by graphics).

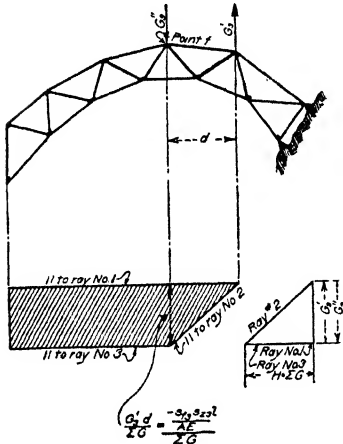

FIG. 19.

In order that the load system G_3' and G_3'' may reproduce the effect of this web strain on the influence line for the Z redundant,

$$-\left[\frac{s_{f3}s_{z3}l}{AE} \right] \text{ must equal } \frac{G_3'd}{\Sigma G}$$

Whence

$$G_3' = - \left[\left(\frac{s_{z3}l}{AE} \right) \left(\frac{s_{f3}}{d} \right) \right]$$

In the above manner the elastic loads G' and G'' and also $G'x$, $G'y$, $G''x$ and $G''y$ for each web member in the frame may be evaluated and the same added to the elastic load lines of Figs. 14, 16 and 17.

One of the two elastic loads G' or G'' for each web member acts downward, the other acting in the opposite direction. To determine which is which, recourse may be had to the following line of reasoning:

For every chord member in the frame the term $\frac{s_{og}g_l}{AE}$ is obviously negative (with the Z redundant acting as assumed).

For any web member therefore if the term $\frac{s_{og}g_l}{AE}$ for a unit load at this same point g , be negative, the elastic loads representing the effect of such web member will have a direction such as to increase the influence ordinate at point g when added to the elastic load line. If, on the other hand, the term $\frac{s_{og}g_l}{AE}$ be positive these loads will have a direction such as to decrease this influence ordinate. In this manner the particular load G' or G'' which acts downward can be readily determined for each web member in the frame.

THE ANALYSIS OF FIXED FRAMED ARCHES

(Symmetrical and Unsymmetrical Spans)

13. Unsymmetrical Spans.—The following method of analysis is simply the application of the formulas derived and demonstrated in the preceding chapter and is applicable to *any* fixed framed arch, either symmetrical, or unsymmetrical, under any system of loading, provided the supports are *rigid* and *unyielding*. The special case of elastic supports will be considered elsewhere.

Let it be required to design the fixed framed arch span shown in Fig. 20, the same being supported on solid rock abutments and having a span length of 275 ft. as shown. The span is taken as unsymmetrical in order to make the problem entirely general. The special case of symmetrical spans will be discussed later.

The procedure is as follows:

Operation No. 1.—Assume tentative dimensions for the depth of frame at skewback and at crown and also tentative values for the cross-sectional areas of the chord members. These dimension and area assumptions are generally based upon previous experience or published data regarding spans of like length and designed for similar load conditions. After the analysis is complete these assumptions will be corrected in accordance with the results obtained and the analysis re-run using the new values of l , A , etc. If these second results are such as to necessitate a considerable modification of the last assumed values of l and A , a third analysis must be made, etc. Generally two or three trials will prove sufficient.

There have been several approximate methods and formulas devised and announced from time to time for determining the approximate size of the arch frame members to guide preliminary assumptions. It is rather doubtful whether this procedure has anything to recommend it over an out and out assumption tempered by judgment and experience. Most certainly it takes more time and generally yields results but very little closer to the final values than those which may be assumed outright by an experienced designer.

Operation No. 2.—Lay out the frame to an adequate scale, assume a *temporary* origin of coordinates (see Fig. 20) and construct two temporary coordinate axes, one vertical and one horizontal through such point.

Operation No. 3.—For each member of the frame (web members are generally neglected their effect being very slight) determine the length l (in feet), the cross-sectional area A (in square feet), the perpendicular distance ρ dropped upon each member from its moment center, and also the coordinates x' and y'' for each of these moment centers measured from the *temporary* origin.

Operation No. 4.—Collect and tabulate the values of l , A , ρ , ρ^2 , $G = \frac{l}{AE\rho^2}$, x' , y'' , Gx' and Gy'' (see Table 1 for the arch under consideration). The term E (29,000,000 \times 144 for steel when pound and foot units are used) occurs in both numerator and denominator of the terms representing the redundants (see Eqs. (74) to (76) inclusive). To avoid long decimals, therefore, E has been taken as 29 in computing the terms G in Table 1, this obviously having no effect on the resulting redundant values.

TABLE 1.—CALCULATION FOR ELASTIC LOADS G AND LOCATION OF THE ELASTIC CENTER O

Member	l (feet)	A (sq. ft.)	ρ (feet)	ρ^2	$G = \frac{l}{AE\rho^2}$	Point of application	x'	y''	Gx'	Gy''
U1-U2	26.85	0.34	29.3	858.49	0.00317	L1	-130.0	16.8	-0.412	0.054
U2-U3	26.75	0.34	25.0	625.00	0.00434	L2	-105.0	30.7	-0.456	0.133
U3-U4	26.02	0.30	23.0	529.00	0.00565	L3	- 82.0	40.3	-0.463	0.228
U4-U5	25.55	0.30	21.8	475.24	0.00618	L4	- 60.0	47.3	-0.371	0.292
U5-U6	25.12	0.30	20.8	432.64	0.00667	L5	- 37.5	52.0	-0.250	0.347
U6-U7	25.02	0.30	20.3	412.09	0.00698	L6	- 12.5	54.6	-0.087	0.381
U7-U8	25.02	0.30	20.3	412.09	0.00698	L7	+ 12.5	54.6	+0.087	0.381
U8-U9	25.12	0.30	20.8	432.64	0.00667	L8	+ 37.5	52.0	+0.250	0.347
U9-U10	25.55	0.30	21.8	475.24	0.00618	L9	+ 60.0	47.3	+0.371	0.292
U10-U11	26.02	0.30	23.0	529.00	0.00565	L10	+ 82.0	40.6	+0.463	0.229
U11-U12	26.07	0.34	26.3	691.69	0.00382	L11	+105.6	30.6	+0.403	0.117
L0-L1	26.00	0.36	31.1	967.21	0.00257	U1	-150.0	40.7	-0.386	0.105
L1-L2	28.71	0.35	26.2	686.44	0.00412	U2	-125.0	49.2	-0.515	0.203
L2-L3	25.10	0.35	24.1	580.81	0.00426	U3	-100.0	59.2	-0.426	0.252
L3-L4	22.92	0.32	22.6	510.76	0.00484	U4	- 75.0	66.7	-0.363	0.323
L4-L5	22.96	0.30	21.5	462.25	0.00571	U5	- 50.0	71.6	-0.286	0.409
L5-L6	25.17	0.30	20.8	432.64	0.00669	U6	- 25.0	74.6	-0.167	0.499
L6-L7	25.00	0.30	20.6	424.36	0.00677	U7	0.0	75.5	0.000	0.511
L7-L8	25.17	0.30	20.8	432.64	0.00669	U8	+ 25.0	74.6	+0.167	0.499
L8-L9	22.96	0.30	21.5	462.25	0.00571	U9	+ 50.0	71.6	+0.286	0.409
L9-L10	22.92	0.32	22.6	510.76	0.00484	U10	+ 75.0	66.7	+0.363	0.323
L10-L11	25.55	0.35	24.5	600.25	0.00419	U11	+100.0	59.2	+0.419	0.248
L11-L12	14.90	0.35	29.0	841.00	0.00175	U12	+125.0	52.1	+0.219	0.091
Σ					1.2043				-1.154	6.673

Operation No. 5.—Locate the position of the center of gravity of the elastic load system ΣG by means of the formulas

$$\bar{x} = \frac{\Sigma Gx'}{\Sigma G}$$

$$\bar{y}'' = \frac{\Sigma Gy''}{\Sigma G}$$

From Table 1

$$\bar{x} = \frac{-1.154}{1.2043} = -9.58 \text{ ft.}$$

$$\bar{y}'' = \frac{6.673}{1.2043} = 55.41 \text{ ft.}$$

It is well to check the position of the "elastic center" (as above determined) graphically, as shown in Fig. 21.

Any two directions for the elastic load system ΣG may be assumed. The two resultants in any case will intersect at the elastic center if the work is correctly done. The directions should be chosen so as to intersect at a well defined angle (as near 90 deg. as possible).

Operation No. 6.—Determine the angle ϕ such that the term

$$\sum \frac{s_x s_y l}{AE} = 0$$

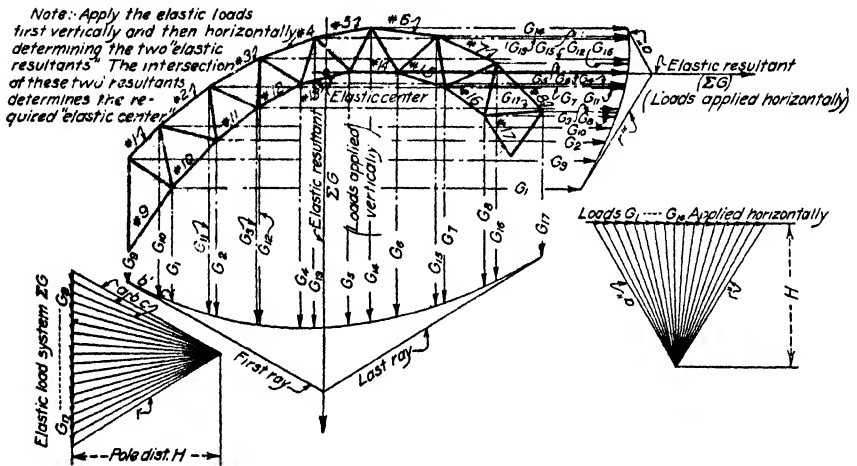

Fig. 21.—Graphical method for determining the "elastic center" of an arch system.

This is done by means of Eq. (73) of the last chapter, the work being as follows:

From Fig. 20

$$x = x' + \bar{x} = x' + 9.58 \text{ ft.}$$

$$y = y'' - \bar{y}'' - x \tan \phi = y'' - 55.41 - (x' + 9.58) \tan \phi$$

Substituting in Eq. (73)

$$\tan \phi = \frac{\Sigma Gx'y'' - 55.41 \Sigma Gx' + 9.58 \Sigma Gy'' - (9.58)(55.41) \Sigma G}{\Sigma G(x')^2 + 2(9.58) \Sigma Gx' + (9.58)^2 \Sigma G}$$

The terms $\Sigma Gx'$ and $\Sigma Gy''$ have already been computed (see Table 1). Table 2 below, contains a tabulation of the terms $\Sigma Gx'y''$ and $\Sigma G(x')^2$ for the problem at hand.

TABLE 2

Member	$Gx'y''$		$G(x')^2$	Member	$Gx'y''$		$G(x')^2$
	(+)	(-)			(+)	(-)	
U1-U2	6.92	53.57	L2-L3	25.22	42.60
U2-U3	14.00	47.85	L3-L4	24.21	27.22
U3-U4	18.66	37.99	L4-L5	20.48	14.28
U4-U5	17.55	22.25	L5-L6	12.46	4.18
U5-U6	13.00	9.38	L6-L7	0.00	0.00	0.00
U6-U7	4.75	1.09	L7-L8	12.46	4.18
U7-U8	4.75	1.09	L8-L9	20.48	14.28
U8-U9	13.00	9.38	L9-L10	24.21	27.22
U9-U10	17.55	22.25	L10-L11	24.80	41.90
U10-U11	18.80	37.99	L11-L12	11.40	27.34
U11-U12	12.33	42.60				
L0-L1	15.71	57.83	Total.....	159.78	198.30	
L1-L2	25.34	64.38				
				Σ	38.52	610.85

Substituting from the above table and from Table 1

Tan ϕ =

$$\frac{-38.52 - (55.41)(-1.154) + (9.58)(6.673) - (9.58)(55.41)(0.1204)}{610.85 - 2(9.58)(1.154) + (9.58)(9.58)(0.1204)} = 0.043$$

Operation No. 7.—Construct two new coordinate axes through the “true elastic center” as found above as follows:

Axis Y-Y vertical

Axis X-X making the angle ϕ with the horizontal.

Compute or scale for each chord member the new coordinates x and y .

x measured *horizontally* from the new axis Y-Y.

y measured *vertically* from the new axis X-X.

x will be taken as positive to the right of the axis Y-Y and negative to the left.

y will be taken as positive above and negative below the axis X-X.

Next compute the terms Gx , Gy , Gx^2 , Gy^2 and the summations ΣG , ΣGx^2 and ΣGy^2 for every chord member of the frame.

This work is tabulated in Table 3 for the arch under discussion.

Operation No. 8.—Considering the frame as a cantilever fixed at the left support (this is the reverse of the condition under which the residual

frame was developed), construct the following three equilibrium polygons:

$$\begin{aligned}
 \text{Polygon } A & \begin{cases} \text{Elastic load system } G \\ \text{Pole distance } H = \Sigma G \end{cases} \\
 \text{Polygon } B & \begin{cases} \text{Elastic load system } Gx \\ \text{Pole distance } H = \Sigma Gx^2 \end{cases} \\
 \text{Polygon } C & \begin{cases} \text{Elastic load system } Gy \\ \text{Pole distance } H = \cos \phi \Sigma Gy^2 \end{cases}
 \end{aligned}$$

From the considerations and demonstrations of the preceding chapter:

Polygon *A* = the influence line for the redundant *Z* (a moment couple) applied at the end of a rigid bracket fastened to the left support and terminating at the elastic center *O*.

TABLE 3

Member	Number	Moment center	<i>G</i>	<i>x</i>	<i>y</i>	<i>Gx</i>	<i>Gy</i>	<i>Gx</i> ²	<i>Gy</i> ²
L0-L1	1	U1	0.00257	-140.42	- 8.67	0.361	0.022	50.69	0.19
U1-U2	2	L1	0.00317	-120.42	-33.43	0.382	0.106	46.00	3.54
L1-L2	3	U2	0.00412	-115.42	- 1.25	0.476	0.005	54.94	0.01
U2-U3	4	L2	0.00434	- 95.42	-20.61	0.414	0.089	39.50	1.83
L2-L3	5	U3	0.00426	- 90.42	+ 7.68	0.385	0.033	34.81	0.25
U3-U4	6	L3	0.00565	- 72.42	-12.00	0.409	0.068	29.61	0.82
L3-L4	7	U4	0.00484	- 65.42	+14.10	0.317	0.068	20.74	0.96
U4-U5	8	L4	0.00618	- 50.42	- 5.94	0.312	0.037	15.73	0.22
L4-L5	9	U5	0.00571	- 40.42	+17.93	0.231	0.102	9.34	1.83
U5-U6	10	L5	0.00667	- 27.92	- 2.21	0.186	0.015	5.19	0.03
L5-L6	11	U6	0.00669	- 15.42	+19.85	0.103	0.133	1.59	2.64
U6-U7	12	L6	0.00698	- 2.92	- 0.68	0.020	0.005	0.06	0.00
L6-L7	13	U7	0.00677	+ 9.58	+19.68	0.065	0.133	0.62	2.62
U7-U8	14	L7	0.00698	+ 22.08	- 1.76	0.152	0.012	3.36	0.02
L7-L8	15	U8	0.00669	+ 34.58	+17.70	0.231	0.118	7.99	2.09
U8-U9	16	L8	0.00667	+ 47.08	- 5.43	0.314	0.037	14.78	0.20
L8-L9	17	U9	0.00571	+ 59.58	+13.63	0.340	0.078	19.92	1.06
U9-U10	18	L9	0.00618	+ 69.58	-11.10	0.430	0.069	29.92	0.77
L9-L10	19	U10	0.00484	+ 84.58	+ 7.65	0.409	0.037	34.59	0.28
U10-U11	20	L10	0.00565	+ 91.58	+19.29	0.517	0.109	47.35	2.10
L10-L11	21	U11	0.00419	+109.58	- 0.92	0.459	0.004	50.30	0.00
U11-U12	22	L11	0.00382	+115.18	-29.78	0.440	0.110	50.68	3.28
L11-L12	23	U12	0.00175	+134.58	- 9.10	0.236	0.016	31.76	0.09
Σ	0.12043	599.47	24.83

Polygon *B* = the influence line for the redundant *Y* applied at the same point and acting vertically upward.

Polygon *C* = the influence line for the redundant *X* applied at the same point and acting to the right along the axis *X-X* (making an angle ϕ with the horizontal).

Referring to Fig. 20, wherein the above influence lines have been constructed, it is observed:

(1) That for polygon *A* the pole distance, for convenience, has been taken as $2.5 \Sigma G$ (in order to plot up at a better scale). The intercepts on this influence line therefore measure to the same scale as the frame layout the term $Z \div 2.5$.

(2) That in a similar manner polygon *B* measures the term $100Y$ and polygon *C* the term $20X$. These constants are merely used to afford a good scale for plotting.

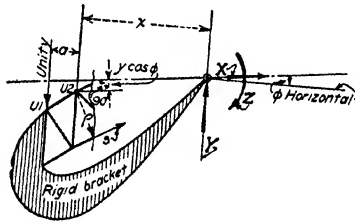
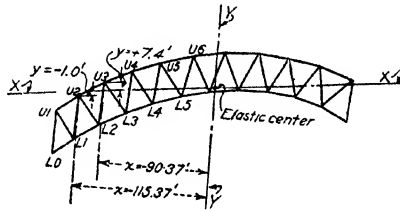

Formulas for influence line Member L1-L2

A For a unit load to the left of panel U2

$$s_0 = \frac{Z}{P}$$

$$s_x = \frac{(-y \cos \phi) - y \cos \phi}{P}$$

$$s_y = \frac{Z}{P}$$

$$s_z = \frac{Z}{P}$$

$$\therefore s = \frac{1}{P} [-\sigma + X y \cos \phi - Y x + Z]$$

B For a unit load to the right of U2

$$s_0 = 0$$

$$\therefore s = \frac{1}{P} [X y \cos \phi - Y x + Z]$$

FIG. 22.

(3) The elastic loads Gx are negative for all points to the left of the elastic center (since x is negative for these points). To take care of this and to avoid confusing the diagram, the pole for the negative loads for polygon *B* is simply thrown to the opposite side of the load line and all loads plotted downward.

Operation No. 9—Stress Influence Lines.—With the influence lines for the redundants once determined as per the above, the stress

influence line for any member of the frame may be very readily determined.

Thus for a *unit* vertical load at any panel point (as for example point *g*) the stress in any frame member becomes

$$s_g = s_{g0} + X_g s_x + Y_g s_y + Z_g s_z$$

due attention being paid to the signs or direction of action of the various forces.

From this equation the *chord stress* influence lines may readily be constructed.

The influence lines for the web members may be readily plotted from the influence lines for the two adjacent lower chord members simply by analyzing the lower joint for each position of the unit load, as shown in Fig. 24. The method of computing the influence lines for both chord and web members is given in complete detail in Tables 4 and 5 and in Figs. 22, 23, 24 and 25.

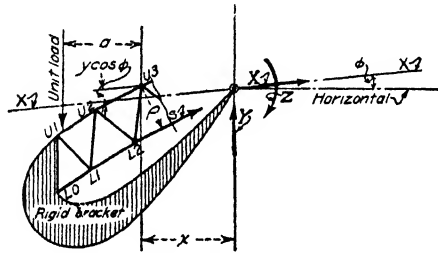

For a unit load to the left of panel point *U3*
 $s = \frac{1}{2} [-a - X_2 \cos \phi - Y_2 x + Z_2]$

For a unit load to the right of panel point *U3*
 $s = \frac{1}{2} [-X_2 \cos \phi - Y_2 x + Z_2]$

FIG. 23.

Operation No. 10—Temperature Stresses, Uniform Temperature Change.—The values of the redundants due to a uniform change in the internal temperature of the frame members are given directly by Eqs. (94) to (96) inclusive of the preceding chapter as follows:

$$X_t = - \frac{\sum s_x c t l}{\cos \phi^2 \sum G y^2}$$

$$Y_t = - \frac{\sum s_y c t l}{\sum G x^2}$$

$$Z_t = - \frac{\sum s_z c t l}{\sum G}$$

TABLE 4.—INFLUENCE LINE DATA FOR MEMBER L1-L2.

Load point	X	Y	Z	α	$Xy \cos \phi$	Yx	S
1	0.000	1.000	140.42	25.0	0.000	115.42	0.000
2	0.055	0.838	116.20		0.069	96.72	0.746
3	0.230	0.738	94.00		0.288	85.18	0.348
4	0.470	0.666	73.00		0.588	76.87	0.125
5	0.700	0.572	54.50		0.875	66.02	0.413
6	0.850	0.457	38.80		1.063	52.75	0.492
7	0.950	0.346	25.50		1.113	39.94	0.509
8	0.750	0.233	15.00		0.938	26.89	0.418
9	0.500	0.134	7.75		0.625	15.47	0.271
10	0.245	0.058	2.50		0.306	6.69	0.043
11	0.060	0.012	1.25		0.075	1.39	0.002
12	0.000	0.000	0.00		0.000	0.00	0.000

$x = -115.42$

$y = -1.25$

$P = 1.00$

$\cos \phi = 0.999$

$\rho = 26.2$

(+) = Tension

(-) = Compression

$$S = \frac{1}{\rho} (Z + Xy \cos \phi - Yx - Pa)$$

TABLE 5.—INFLUENCE LINE DATA FOR MEMBER L2-L3.

Load point	X	Y	Z	α	$Xy \cos \phi$	Yx	S
1	0.000	1.000	140.42	50.0	0.00	90.42	0.000
2	0.055	0.838	116.20	25.0	0.42	75.77	+0.623
3	0.230	0.738	94.00		1.76	66.73	+1.059
4	0.470	0.666	73.00		3.60	60.22	+0.381
5	0.700	0.572	54.50		5.37	51.72	-0.107
6	0.850	0.457	38.80		6.52	41.32	-0.375
7	0.890	0.346	25.50		6.83	31.29	-0.524
8	0.750	0.233	15.00		5.75	21.07	-0.490
9	0.500	0.134	7.75		3.84	12.12	-0.341
10	0.245	0.058	2.50		1.88	5.24	-0.192
11	0.060	0.012	1.25		0.46	1.08	-0.012
12	0.000	0.000	0.00		0.00	0.00	0.000

$x = -90.42$

$y = +7.68$

$P = 1.00$

$\cos \phi = 0.999$

$\rho = 24.1$

(+) = Tension

(-) = Compression

$$S = \frac{1}{\rho} (Z - Xy \cos \phi - Yx - Pa)$$

TABLE 6.—VALUES OF REDUNDANTS
FOR
A UNIFORM TEMPERATURE RISE OF 40° F.

(+) = { Extension
Tension

(-) = { Compression
Shortening

Member	ctl 40° rise (+)	$\frac{s_x}{\cos \phi} = \frac{-y}{\rho}$	$s_y = \frac{x}{\rho}$	$s_z = \frac{1}{\rho}$	$\frac{s_x \text{ctl}}{\cos \phi}$		$s_y \text{ctl}$		$s_z \text{ctl}$	
					+	-	+	-	+	-
U1-U2	0.00645	-1.141	+4.11	-0.0341	0.00736	0.0265			0.000220	
U2-U3	0.00642	-0.824	+3.82	-0.0400	0.00529	0.0245			0.000257	
U3-U4	0.00625	-0.522	+3.15	-0.0435	0.00326	0.0197			0.000272	
U4-U5	0.00613	-0.273	+2.31	-0.0459	0.00167	0.0142			0.000281	
U5-U6	0.00604	-0.106	+1.34	-0.0481	0.00064	0.0081			0.000290	
U6-U7	0.00601	-0.033	+0.14	-0.0493	0.00020	0.0009			0.000296	
U7-U8	0.00601	-0.087	-1.09	-0.0493	0.00052		0.0065		0.000206	
U8-U9	0.00604	-0.268	-2.32	-0.0493	0.00162		0.0140		0.000298	
U9-U10	0.00613	-0.509	-3.19	-0.0459	0.00312		0.0196		0.000281	
U10-U11	0.00625	-0.839	-3.98	-0.0435	0.00524		0.0249		0.000272	
U11-U12	0.00625	-0.132	-4.38	-0.0380	0.00708		0.0274		0.000238	
L0-L1	0.00625	+0.279	-4.52	+0.0322	0.00174		0.0282	0.000201		
L1-L2	0.00689	+0.048	-4.41	+0.0382	0.00033		0.0304	0.000263		
L2-L3	0.00604	-0.319	-3.75	+0.0415	0.00192		0.0227	0.000251		
L3-L4	0.00551	-0.624	-2.80	+0.0442	0.00344		0.0160	0.000244		
L4-L5	0.00552	-0.834	-1.88	+0.0465	0.00460		0.0104	0.000257		
L5-L6	0.00604	-0.954	-0.74	+0.0481	0.00576		0.0045	0.000290		
L6-L7	0.00600	-0.955	+0.47	+0.0485	0.00573	0.0028		0.000291		
L7-L8	0.00604	-0.851	+1.66	+0.0481	0.00514	0.0100		0.000291		
L8-L9	0.00552	-0.634	+2.77	+0.0465	0.00350	0.0153		0.000257		
L9-L10	0.00551	-0.339	+3.74	+0.0442	0.00187	0.0206		0.000244		
L10-L11	0.00614	+0.038	+4.47	+0.0408	0.00023	0.0275		0.000250		
L11-L12	0.00357	+0.314	+4.64	+0.0345	0.00112	0.0166		0.000123		
Σ (+)					0.00342	0.1887		0.002962		
Σ (-)					0.06796	0.2046		0.003001		
Σ	Net total				0.06454	0.0179	0.000039			

For a uniform rise in temperature of 40° F. the values of the numerators for the above equations have been computed and tabulated in Table 6 as follows:

$$\begin{aligned} \sum \frac{s_x \text{ctl}}{\cos \phi} &= -0.06454 \\ \sum s_x \text{ctl} &= -0.06454 (\cos \phi) = -0.06448 \\ \sum s_y \text{ctl} &= -0.0179 \\ \sum s_z \text{ctl} &= -0.000039 \\ \cos \phi &= (\text{approx.}) 0.999 \end{aligned}$$

In Table 3 the values ΣG , ΣGx^2 , ΣGy^2 , etc. were computed using the value $E = 29$. This assumption made no difference in the values of the redundants due to gravity loadings inasmuch as the term E occurred in both numerator and denominator of the expressions for the redundant forces (see Eqs. (74) to (76) inclusive). For temperature stresses, on the other hand, the term E occurs only in the denominator (see Eqs. (77) to (79), inclusive).

The true value of E is generally taken as 29,000,000 lb. per sq. in. or (29,000,000)(144) lb. per sq. ft.,

The values in Table 3 must therefore be divided by 144,000,000 for use in the above formulas.

Using these values we therefore write

$$X_t = - \left[\frac{(-0.06448)(144,000,000)}{(0.999)^2(24.83)} \right] = 375,000 \text{ lb.}$$

$$Y_t = - \left[\frac{(-0.0179)(144,000,000)}{599.47} \right] = 4,300 \text{ lb.}$$

$$Z_t = - \left[\frac{(-0.000039)(144,000,000)}{1.2043} \right] = 46,600 \text{ ft.-lb.}$$

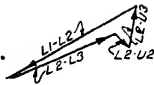
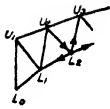

Analysis of Joint L2

Method of plotting web stress influence lines from those for lower chord members. Joint L2 is analyzed for each position of the unit load, thus determining the stress in L2-U2 and L2-U3 for such loading

FIG. 24.

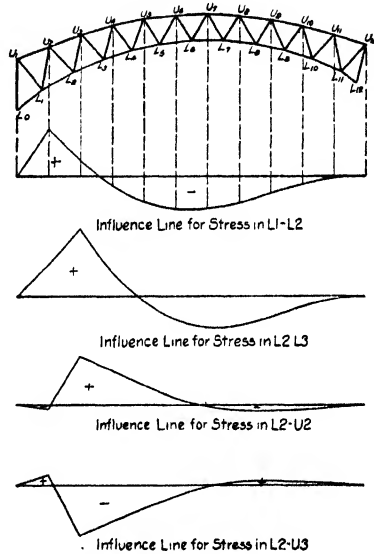

FIG. 25.

The redundant moment Z_t due to a uniform change in internal temperature is practically negligible. In fact this moment would be exactly zero if the top and bottom arch chords were of exactly the same length, since in this case there would be no angular distortion resulting from expansion or contraction of the frame.

We may therefore neglect the term Z_t in calculating the temperature stress in any frame member.

With the temperature redundants determined as above, the stress in any frame member is obviously given by the formula

$$S_t = S_{ot} + X_t s_x + Y_t s_y + Z_t s_z$$

or

$$X_t s_x + Y_t s_y + Z_t s_z$$

since S_{ot} (the temperature stress in any member of the statically determinate residual cantilever) will always be zero.

In the above

Z_t may be taken as zero without material error.

Also

$$s_x = \frac{-y \cos \phi}{\rho} \text{ and } s_y = \frac{x}{\rho}$$

Whence

$$S_t = (-X_t y \cos \phi + Y_t x) \div \rho$$

For example the temperature stress in chord member L2-L3 is

$$\frac{-375,000 \text{ lb. (7.68 in.)(0.999) + 4,300 lb. (-90.42 in.)}{24.1 \text{ ft.}} = -135,500 \text{ lb.}$$

Note that this is a compressive stress in the lower chord. For a drop in temperature the signs of c/l in Table 6 would be reversed and the redundants would all have reversed directions. The above stress S_t would then become +135,500 lb. or a tension in the lower chord member L2-L3.

In the above manner the temperature stresses in each member of the frame may be readily calculated.

Operation No. 11—Stresses Due to a Variable Temperature Change.—It is sometimes desirable to know the stresses which would result from a non-uniform change in temperature throughout the various members of the frame. For example it is quite probable that during the hottest summer weather the upper chord members assume a temperature considerably higher than those of that portion of the lower chord which is more or less shaded by the deck.

These stresses for any given or desired assumption as to temperature distribution may be calculated exactly as has been done above for the uniform temperature change by varying the value of t in column two of Table 6 in accordance with the assumed facts.

In this case it is well to observe that the term Z_t is no longer negligible.

14. Symmetrical Spans.—For symmetrical spans the elastic center will obviously lie on a vertical through the center of the span and may therefore be completely located by applying the elastic load system horizontally thus locating the vertical position of said elastic center.

For coordinates measured from the true elastic center as above determined, the terms \bar{y} and \bar{x} of Eq. (73) both vanish and thus equation may be written

$$\tan \phi = \frac{\Sigma Gx'y''}{\Sigma G(x')^2}$$

Since the span is symmetrical, for every value of y'' there are two equal and opposite values of x' , therefore the term $\Sigma Gx'y''$ also vanishes and we have

$$\tan \phi = 0$$

For symmetrical spans, therefore, the two redundants are "conjugated" when they are at right angles to each other, one horizontal and one vertical.

The above represents the only difference in procedure, in all other respects the analysis of symmetrical arch frames will be as hereinabove described for unsymmetrical spans.

Temperature Effects.—If the span is symmetrical, the term Y_t becomes zero. That this is true may be seen from the following:

For every positive value of x there is a corresponding panel point having an equal negative value, therefore

$$\sum s_v c t l = \sum_{\rho}^x c t l = 0$$

and

$$Y_t = 0$$

The temperature stress in any member may then be expressed (neglecting the term Z_t as before)

$$S_t = X_t s_x$$

The above holds true for uniform temperature effects only. That it cannot hold for variable temperature effects is, of course, self-evident.

DEVELOPMENT OF GENERAL ELASTIC EQUATIONS FOR RIB ARCHES

15. Development of Formulas.—Let Fig. 26 represent any fixed arch rib at rest and in equilibrium under the action of any system of external loads ΣF and the rigid anchorage at each abutment. If the two abutments were to be removed, it is clearly seen that the action of each abutment could be exactly reproduced by the introduction at each support of a moment couple M , an axial thrust N , and a tangential or shearing force V (Fig. 26*b*). It is also apparent that, if the value of these six forces under any given load condition, can be determined, the stress in the rib at any point may very easily be found.

There are three fundamental static equations of equilibrium which may be written for any structure, as follows:

$$\begin{aligned} \Sigma(\text{Horizontal forces, or components}) &= 0 \\ \Sigma(\text{Vertical forces, or components}) &= 0 \\ \Sigma(\text{Moments about any point}) &= 0 \end{aligned}$$

These three equations, therefore, suffice for the determination of three of the six above unknown reaction components, leaving three others which must be determined.

If, therefore, either support (say the left support) be removed and the three forces N , V , and M , be inserted to reproduce the action of this same support as shown in Fig. 27*a*, the problem at once resolves itself into that

of evaluating these three unknown forces. Once these are determined, the other three reaction components and the stress in the rib at any point are easily determined from the above static equations.

Carrying the reasoning a step further, let us replace the three forces N , V , and M , by a rigid bracket or arm fastened to the rib at the left support and terminating at some point O . At the end of this bracket let us apply three new unknown forces as shown in Fig. 27b, as follows:

- X = the unknown lateral component at point O .
- Y = the unknown vertical component at point O .
- Z = the unknown moment couple at point O .

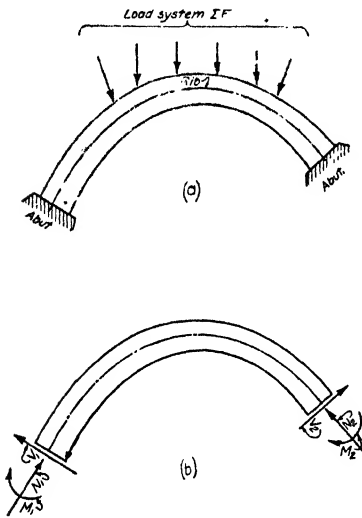

FIG. 26.

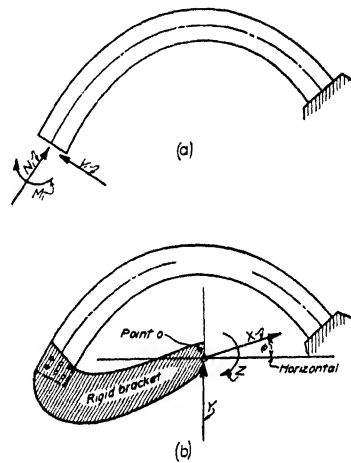

FIG. 27.

It is apparent that these forces may be given a value such that they will exactly reproduce the action of the forces N , V , and M , at the left abutment and will consequently hold the structure in equilibrium.

It is also apparent that, if these three new unknown forces can be determined, the original reaction components N , V , and M , can easily be obtained and consequently the other reaction components (and the rib stresses as well) may be readily evaluated from statics.

This last step (the employment of the rigid bracket idea) simply replaces three unknown forces applied at the left abutment with three other unknowns applied at point O . This may seem entirely unnecessary. However, such is not the case, for by properly choosing the location for point O , the terminal point of the rigid bracket, the equations involving the unknowns X , Y and Z (to be derived hereinafter) become very greatly simplified.

If the three forces X , Y and Z were to be entirely removed, the resulting structure would become a cantilever. In any statically indeterminate structure there are always one or more unknown forces or reaction components which may be removed to produce a statically determinate structure (see p. 408). The structure resulting from the removal of these forces is generally termed the "residual frame" and the forces themselves

are termed "redundants." In this case X , Y , and Z are the "redundants" and the "residual frame" is a cantilever (compare with Art. 6, p. 409).

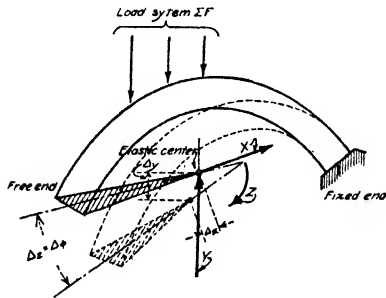

FIG. 28.

Consider the residual frame (a cantilever rib) shown in Fig. 28 under the action of any given system of external loading, together with the resultant redundant forces X , Y and Z . Under the action of these loads the terminal point O of

the rigid bracket undergoes certain elastic displacements both angular and linear as shown.

Let

Δ_y = the displacement of point O along the line of action of the redundant Y .

Δ_x = the displacement of point O along the line of action of the redundant X .

Δ_z = the angular displacement of the bracket in the direction chosen for the redundant Z .

Referring back to Art. 4, p. 406, we find these displacements to be given by the following expressions (neglecting the effect of shearing distortions, see Eq. (39)):

$$\Delta_x + \Delta_{t_x} + \Delta_{t'_x} - \Sigma r_x \Delta_r = \Sigma \frac{N n_x ds}{AE} + \Sigma \frac{M m_x ds}{EI} + \Sigma n_x c t ds + \Sigma \frac{m_x c t' ds}{h} \quad (97)$$

$$\Delta_y + \Delta_{t_y} + \Delta_{t'_y} - \Sigma r_y \Delta_r = \Sigma \frac{N n_y ds}{AE} + \Sigma \frac{M m_y ds}{EI} + \Sigma n_y c t ds + \Sigma \frac{m_y c t' ds}{h} \quad (98)$$

$$\Delta_z + \Delta_{t_z} + \Delta_{t'_z} - \Sigma r_z \Delta_r = \Sigma \frac{N n_z ds}{AE} + \Sigma \frac{M m_z ds}{EI} + \Sigma n_z c t ds + \Sigma \frac{m_z c t' ds}{h} \quad (99)$$

In the above equations the various terms have the following significance:

Δ_x = the displacement as previously defined caused by the load system ΣF applied as shown, in combination with the unknown forces X , Y , and Z resulting therefrom. This displacement is measured along the line of action of the redundant X .

Δ_y and Δ_z = similar displacements due to the same loading, but measured along the line of action of the redundants Y and Z (Δ_z is therefore an angular displacement).

Δ_{t_x} , Δ_{t_y} and Δ_{t_z} = displacements measured as above caused by a uniform change in temperature of t° .

$\Delta_{t'_x}$, $\Delta_{t'_y}$ and $\Delta_{t'_z}$ = similar displacements caused by a variable change in temperature of t'° between the upper and lower fibers of the rib.

The terms r_x , r_y , r_z , $\Sigma r_x \Delta r$,

$\Sigma r_y \Delta r$, etc. = as defined in Art. 2, p. 400.

M_o = the moment on the residual cantilever at any point due solely to the load system ΣF .

m_x = the moment at any point on the residual cantilever due solely to a unit load applied at O and acting along the line of action of the redundant X .

m_y = the moment at any point on the residual cantilever due solely to a unit load as above but acting along the line of action of the redundant Y .

m_z = the moment at any point on the residual cantilever due solely to a unit moment couple applied at point O and acting in the direction assumed for the redundant Z .

N_o , n_x , n_y , n_z , etc. are defined as above but refer to axial thrusts in place of moments.

ds , E , I , cl , A , t' , and h as previously defined (Arts. 3 and 4, pp. 402 and 406).

Now it is observed that the unknown redundants X , Y and Z applied at O completely replace and reproduce the action of the left arch abutment. For any point therefore:

The $\left\{ \begin{array}{l} \text{stress} \\ \text{reaction} \\ \text{displacement} \\ \text{deflection} \end{array} \right\}$ on the given arch rib due to any given loading

is always equal to the corresponding $\left\{ \begin{array}{l} \text{stress} \\ \text{reaction} \\ \text{displacement} \\ \text{deflection} \end{array} \right\}$ on the residual

cantilever due to this same loading plus the effect of the redundant forces X , Y , and Z caused by such loading (compare with Art. 7, p. 410).

If therefore:

M = the bending moment at any point in the arch rib due to any given loading.

M_o = the bending moment at the same point in the residual cantilever due to this same loading.

Then:

$$\begin{aligned} M &= M_o + M_x + M_y + M_z \\ &= M_o + X m_x + Y m_y + Z m_z \end{aligned} \quad (100)$$

In a similar manner

$$N = N_o + X n_x + Y n_y + Z n_z \quad (101)$$

We may now write Eqs. (97) to (99) as follows:

$$\begin{aligned} \Delta_x + \Delta_{tx} + \Delta_{t'x} - \Sigma r_x \Delta_r &= \Sigma \frac{N_o n_x ds}{AE} + \Sigma \frac{M_o m_x ds}{EI} + \\ &X \left[\Sigma \frac{(n_x)^2 ds}{AE} + \Sigma \frac{(m_x)^2 ds}{EI} \right] + Y \left[\Sigma \frac{n_x n_y ds}{AE} + \Sigma \frac{m_x m_y ds}{EI} \right] + \\ &Z \left[\Sigma \frac{n_x n_z ds}{AE} + \Sigma \frac{m_x m_z ds}{EI} \right] + \Sigma n_x c t ds + \Sigma \frac{m_x c t' ds}{h} \end{aligned} \quad (102)$$

$$\begin{aligned} \Delta_y + \Delta_{ty} + \Delta_{t'y} - \Sigma r_y \Delta_r &= \Sigma \frac{N_o n_y ds}{AE} + \Sigma \frac{M_o m_y ds}{EI} + \\ &X \left[\Sigma \frac{n_x n_y ds}{AE} + \Sigma \frac{m_x m_y ds}{EI} \right] + Y \left[\Sigma \frac{(n_y)^2 ds}{AE} + \Sigma \frac{(m_y)^2 ds}{EI} \right] + \\ &Z \left[\Sigma \frac{n_y n_z ds}{AE} + \Sigma \frac{m_y m_z ds}{EI} \right] + \Sigma n_y c t ds + \Sigma \frac{m_y c t' ds}{h} \end{aligned} \quad (103)$$

$$\begin{aligned} \Delta_z + \Delta_{tz} + \Delta_{t'z} - \Sigma r_z \Delta_r &= \Sigma \frac{N_o n_z ds}{AE} + \Sigma \frac{M_o m_z ds}{EI} + \\ &X \left[\Sigma \frac{n_x n_z ds}{AE} + \Sigma \frac{m_x m_z ds}{EI} \right] + Y \left[\Sigma \frac{n_y n_z ds}{AE} + \Sigma \frac{m_y m_z ds}{EI} \right] + \\ &Z \left[\Sigma \frac{(n_z)^2 ds}{AE} + \Sigma \frac{(m_z)^2 ds}{EI} \right] + \Sigma n_z c t ds + \Sigma \frac{m_z c t' ds}{h} \end{aligned} \quad (104)$$

These are the *general elastic equations* applicable to the analysis of any fixed rib arch and correspond in general to Eqs. (43), (44) and (45) written for fixed framed arches.

The terms $\frac{n_x ds}{AE}$, $\frac{n_x n_y ds}{AE}$, $\frac{(n_y)^2 ds}{AE}$ etc. are relatively very small, representing the distortions due to unit axial stresses. Except for very flat arches, these terms may be disregarded without material error. This will be done hereinafter except in considering the effect of axial stress or "rib shortening" as discussed later on.

Case I—Rigid Supports—Temperature Effects Neglected.—If the supports are rigid and inelastic, the above equations may be very much

simplified, inasmuch as the entire left-hand member of each equation becomes zero for such a condition.

Ignoring temperature effects, and disregarding the terms $\frac{(n_x)^2 ds}{AE}$, $\frac{n_x n_y ds}{AE}$ etc. as above set forth, these equations may be written as follows:

$$X \sum \frac{(m_x) ds}{EI} + Y \sum \frac{m_x m_y ds}{EI} + Z \sum \frac{m_x m_z ds}{EI} = - \sum \frac{N_o n_x ds}{AE} - \sum \frac{M_o m_x ds}{EI} \tag{105}$$

$$X \sum \frac{m_x m_y ds}{EI} + Y \sum \frac{(m_y)^2 ds}{EI} + Z \sum \frac{m_y m_z ds}{EI} = - \sum \frac{N_o n_y ds}{AE} - \sum \frac{M_o m_y ds}{EI} \tag{106}$$

$$X \sum \frac{m_x m_z ds}{EI} + Y \sum \frac{m_y m_z ds}{EI} + Z \sum \frac{(m_z)^2 ds}{EI} = - \sum \frac{N_o n_z ds}{AE} - \sum \frac{M_o m_z ds}{EI} \tag{107}$$

Case II—Effect of a Uniform Change in Temperature (Rigid Supports).—The elastic equations for this condition may be readily written from Eqs. (102) to (104) inclusive by placing the left-hand member of each equation equal to zero, as in Case I, and also placing the terms M_o , N_o and t' each equal to zero, whence we write (ignoring the terms $\frac{(n_x)^2 ds}{AE}$, $\frac{n_x n_y ds}{AE}$ etc. as set forth above):

$$X \sum \frac{(m_x)^2 ds}{EI} + Y \sum \frac{m_x m_y ds}{EI} + Z \sum \frac{m_x m_z ds}{EI} = - \Sigma n_x c t ds \tag{108}$$

$$X \sum \frac{m_x m_y ds}{EI} + Y \sum \frac{(m_y)^2 ds}{EI} + Z \sum \frac{m_y m_z ds}{EI} = - \Sigma n_y c t ds \tag{109}$$

$$X \sum \frac{m_x m_z ds}{EI} + Y \sum \frac{m_y m_z ds}{EI} + Z \sum \frac{(m_z)^2 ds}{EI} = - \Sigma n_z c t ds \tag{110}$$

Case III—Effect of a Variable Change in Temperature.—In a manner exactly analogous to the above these equations become:

$$X \sum \frac{(m_x)^2 ds}{EI} + Y \sum \frac{m_x m_y ds}{EI} + Z \sum \frac{m_x m_z ds}{EI} = - \frac{\Sigma m_x c t' ds}{h} \tag{111}$$

$$X \sum \frac{m_x m_y ds}{EI} + Y \sum \frac{(m_y)^2 ds}{EI} + Z \sum \frac{m_y m_z ds}{EI} = - \frac{\Sigma m_y c t' ds}{h} \tag{112}$$

$$X \sum \frac{m_x m_z ds}{EI} + Y \sum \frac{m_y m_z ds}{EI} + Z \sum \frac{(m_z)^2 ds}{EI} = - \frac{\Sigma m_z c t' ds}{h} \tag{113}$$

The individual terms $n_x c t ds$, $n_y c t ds$, $\frac{m_x c t' ds}{h}$, $\frac{m_y c t' ds}{h}$, etc. carry positive signs when the distortions due to the unit thrusts and moments n_x , n_y , m_x , m_y , etc., are in the same direction as those produced by the temperature change, and *vice versa*.

DEVELOPMENT OF ELASTIC INFLUENCE LINES FOR RIB ARCHES

16. **Development of Formulas.**—Consider the fixed arch rib shown in Fig. 29, which, in order to make the problem entirely general, has been taken as unsymmetrical. Through the terminal point *O* of the assumed rigid bracket, construct two coordinate axes as follows:

Y-Y vertical

X-X acting along the line of action assumed for the redundant *X* and thus making some angle ϕ (as yet unknown) with the horizontal.

Let us measure the abscissas (*x*) horizontally, calling the signs positive to the right of the Y-Y axis, and let us measure the *Y* ordinates vertically, calling the signs positive above the X-X axis.

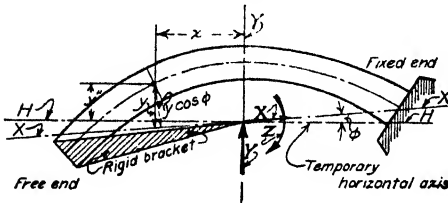

FIG. 29.

Assume the three redundant forces to act as shown in Fig. 29. (These redundants may be arbitrarily assumed to act in either direction. If the true direction is opposite to that assumed, the signs will simply come out negative.)

Moments causing compressive stresses in the upper fiber of the residual cantilever will be assumed as positive, and conversely.

From inspection of the figure

$$m_x = -y \cos \phi \tag{114}$$

$$m_y = x \tag{115}$$

$$m_z = 1.0 \tag{116}$$

Divide the arch ring into small equal segments, as shown in Fig. 30, and compute for each segment the term $\frac{m_x ds}{I} = \frac{ds}{I}$, where *ds* is the length of the segment and *I* is the moment of inertia of the rib at the center of said segment. The term $\frac{ds}{I}$ is sometimes called the “elastic weight” of each voussoir or arch block and will hereinafter be designated by the term *G*.

We may now write Eqs. (105) to (107) inclusive (after multiplying them by the term *E*) as follows:

$$X \cos \phi^2 \Sigma G y^2 - Y \cos \phi \Sigma G x y - Z \cos \phi \Sigma G y = - \sum \frac{N_x n_x ds}{A} + \cos \phi \Sigma M_x G y \tag{117}$$

$$-X \cos \phi \Sigma G x y + Y \Sigma G x^2 + Z \Sigma G x = - \sum \frac{N_x n_y ds}{A} - \Sigma M_x G x \tag{118}$$

$$-X \cos \phi \Sigma G y + Y \Sigma G x + Z \Sigma G = - \sum \frac{N_x n_z ds}{A} - \Sigma M_x G \tag{119}$$

Now if the terms $G = \frac{ds}{I}$ are considered as weights applied at the center of each voussoir or arch block, and the terminal point O made coincident with the center of gravity of such "elastic" system, we observe at once that

$$\begin{aligned} \Sigma Gx &= 0 \\ \Sigma Gy &= 0 \end{aligned}$$

Proceeding a step further it is also observed that the angle ϕ may be so taken as to make the term $\Sigma Gxy \cos \phi$ vanish also. This last procedure is as follows:

Through the origin O construct a temporary horizontal axis $H-H$ and let y'' represent the vertical ordinate to the center of each ds segment scaled from such axis.

$$\text{Then } \begin{cases} y = y'' - x \tan \phi & (120) \\ \Sigma Gxy = \Sigma Gxy'' - \Sigma Gx^2 \tan \phi & (121) \end{cases}$$

Placing this last expression equal to zero and solving for the angle ϕ we have

$$\phi = \tan^{-1} \frac{\Sigma Gxy''}{\Sigma Gx^2} \tag{122}$$

from which equation the value of ϕ may be readily determined.

Two axes $X-X$ and $Y-Y$, so located that ΣGxy vanishes, are termed "conjugate" axes and the operation above described is termed "conjugating the redundants."

Applying the redundants X and Y along the conjugate axes above determined and locating the terminal point O at the center of gravity of the "elastic load system," which point will be hereinafter termed the "elastic center," we may write Eqs. (117),(118) and (119) as follows:

$$X = - \left[\frac{\Sigma \frac{N_o n_x ds}{A} - \cos \phi \Sigma M_o Gy}{\cos \phi^2 \Sigma Gy^2} \right] \tag{123}$$

$$Y = - \left[\frac{\Sigma \frac{N_o n_y ds}{A} + \Sigma M_o Gx}{\Sigma Gx^2} \right] \tag{124}$$

$$Z = - \left[\frac{\Sigma \frac{N_o n_z ds}{A} + \Sigma M_o G}{\Sigma G} \right] \tag{125}$$

The first term in the numerator of each of the above expressions represents the effect of the axial thrust and may be disposed of in the same

manner as is done with uniform temperature effects. Neglecting this term for the present, therefore, the above expressions may be written

$$X = \frac{\Sigma M_o G y}{\cos \phi \Sigma G y^2} \tag{126}$$

$$Y = - \frac{\Sigma M_o G x}{\Sigma G x^2} \tag{127}$$

$$Z = - \frac{\Sigma M G_o}{\Sigma G} \tag{128}$$

By means of the above equations the values of the redundant forces

X , Y , and Z may be evaluated for any given condition of loading.

It will be observed, however, that this method necessitates the solution of each equation for every possible position of the dead and live loads and is therefore somewhat lengthy. A much easier and simpler method is to assume a unit load at any given point, compute the value of the term M_o for such load and solve for the redundants X , Y , and Z induced by such unit load. Then

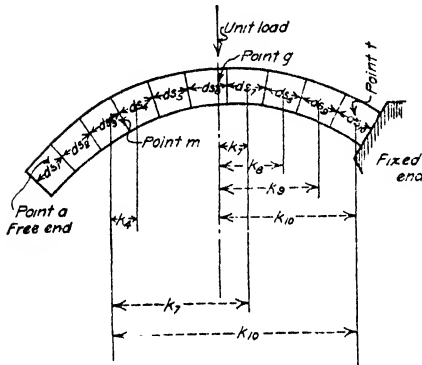

FIG. 30.

by moving this unit load across the span, values of the redundants may be obtained for each position of the unit load and an influence line constructed for each of the redundant forces.

Placing a unit load at any point g (see Fig. 30) we may at once write

$$M_o = - 0 \text{ (for any point between } a \text{ and } g)$$

$$M_o = - k \text{ (for any point between } g \text{ and } t)$$

$$\Sigma M_o G = \sum_a^g G(0) + \sum_g^t G(-k) = - \sum_g^t Gk \tag{129}$$

Whence Eqs. (126) to (128) inclusive above, become

$$X_g = \frac{- \sum_a^t k G y}{\cos \phi \Sigma G y^2} \tag{130}$$

$$Y_g = - \frac{\sum_a^t k G x}{\Sigma G x^2} \tag{131}$$

$$Z_g = - \frac{\sum_a^t k G}{\Sigma G} \tag{132}$$

(The minus sign is used before the term k because it represents a moment which causes tension in the upper fibers of the residual cantilever.)

Placing a unit load at any other point m and proceeding in an exactly similar manner we find

$$X_m = \frac{-\sum_m^t kGy}{\cos \phi \Sigma Gy^2} \tag{133}$$

$$Y_m = \frac{\sum_m^t kGx}{\Sigma Gx^2} \tag{134}$$

$$Z_m = \frac{\sum_m^t kG}{\Sigma G} \tag{135}$$

By means of the above equations it is possible to plot an influence line for the redundant reaction components X , Y , and Z for any arch ring having rigid supports. With these influence lines plotted, the value of the redundants can be easily determined for any given set of load conditions and from these the stress in the rib at any point may be easily computed.

17. Graphical Solution for Redundant Influence Diagrams.—The foregoing method of calculating the influence line ordinates for the redundants X , Y , and Z involves the summation of the terms given in the numerator once for every position of the moving unit load and is therefore somewhat laborious. An easier and more rapid method may be developed graphically as follows:

Consider the given arch rib as a cantilever fixed at the *left* support and free at the *right* support (note that this is the reverse of the condition under which the redundants X , Y , and Z were first developed). Load each ds segment at its center with the corresponding elastic load $G = \frac{ds}{I}$.

With pole distance ΣG construct a ray diagram for these loads and an equilibrium polygon (polygon A , Fig. 31). The intercept on this polygon by a vertical through any point (as point g) is obviously measured by the term

$$\frac{\sum_g^t kG}{\Sigma G} = Z_g \tag{136}$$

Polygon A is therefore the influence line for the redundant Z.

Now load the rib with the load system Gy and construct an equilibrium polygon (polygon B , Fig. 31) with pole distance $\Sigma Gy^2 \cos \phi$. The intercept on this polygon by a vertical through any point (as point g) is obviously measured by the term

$$\frac{-\sum_g^t kGy}{\Sigma Gy^2 \cos \phi} = X_g \tag{137}$$

Polygon B is therefore the influence diagram for the redundant X.

In a similar manner polygon *C* (Fig. 31), using the load line Gx and a pole distance $H = \Sigma Gx^2$, becomes the influence line for the redundant *Y*.

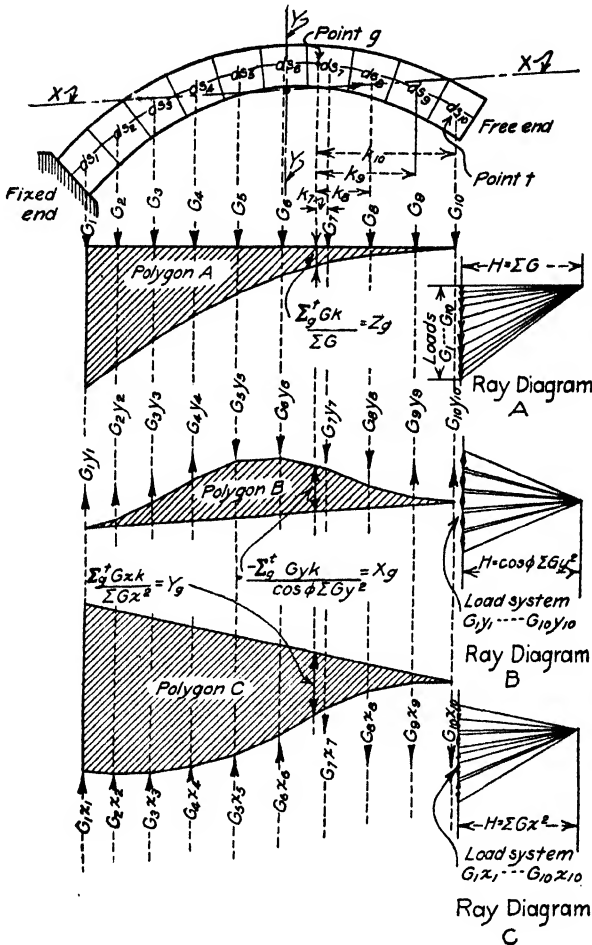

FIG. 31.—Reversed cantilever.

Having these influence lines plotted the determination of stresses at any point in the rib becomes a problem involving ordinary statics. This phase of the work is discussed in the next chapter.

18. Stresses Due to Uniform Temperature Changes.—With the terminal point of the rigid bracket located at the “elastic center” and with the redundants *X* and *Y* properly “conjugated” the following simplifi-

ations for Eqs. (108), (109), and (110) (see Case II, p. 445) may be written:

$$\sum \frac{(m_x)^2 ds}{EI} = \frac{\cos \phi^2}{E} \Sigma G y^2 \tag{138}$$

$$\sum \frac{m_x m_y ds}{EI} = \frac{-\cos \phi}{E} (\Sigma G x y) = 0 \tag{139}$$

$$\sum \frac{m_x m_z ds}{EI} = \frac{-\cos \phi}{E} (\Sigma G y) = 0 \tag{140}$$

$$\sum \frac{(m_y)^2 ds}{EI} = \frac{1}{E} \Sigma G x^2 \tag{141}$$

$$\sum \frac{m_y m_z ds}{EI} = \frac{1}{E} (\Sigma G x) = 0 \tag{142}$$

$$\sum \frac{(m_z)^2 ds}{EI} = \frac{1}{E} \Sigma G \tag{143}$$

Also from Fig. 32:

$$n_x = \cos \theta \tag{144}$$

$$n_y = \sin (\theta + \phi) \tag{145}$$

$$n_z = 0 \tag{146}$$

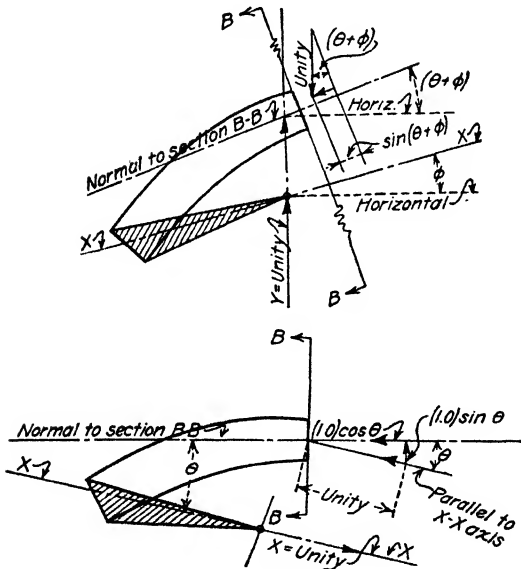

FIG. 32.

The axial fiber distortion caused by the loading $X = \text{unity}$ acting as assumed is a compression or *shortening* of the rib. Therefore, the individual products $\cos \theta ctds$ will be *positive* for a temperature drop and *negative* for a temperature rise. The sign before the individual products $\sin (\theta + \phi) ctds$ will obviously be *positive* for a temperature drop when $(\theta + \phi)$ is positive and *negative* when $(\theta + \phi)$ is negative.

Applying these formulæ

$$X_t = \frac{-E \Sigma \pm \cos \theta ctds}{\cos \phi^2 \Sigma G y^2} \quad (147)$$

Similarly

$$Y_t = \frac{-E \Sigma \pm \sin (\theta + \phi) ctds}{\Sigma G x^2} \quad (148)$$

$$Z_t = 0 \quad (149)$$

From Fig. 33

$$\Sigma \cos \theta ds = L' \quad (150)$$

$$\Sigma \sin (\theta + \phi) ds = L'' \quad (151)$$

Whence

$$X_t = \pm \left[\frac{EctL'}{\cos \phi^2 \Sigma G y^2} \right] \quad (152)$$

$$Y_t = \pm \left[\frac{EctL''}{\Sigma G x^2} \right] \quad (153)$$

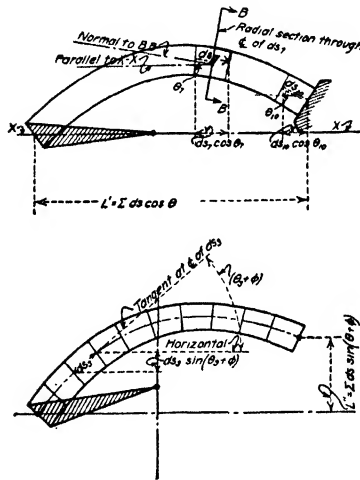

FIG. 33.

Obviously the plus signs are to be used for a temperature rise and the minus signs for a temperature drop.

19. Stresses Due to a Variable Temperature Change.—Using the simplification identities listed in Art. 18, above Eqs. (111), (112), and (113) of Case III, p. 445, may be written

$$X_r = \pm \left[\frac{ct' E \Sigma y ds / h}{\cos \phi \Sigma G y^2} \right] \quad (154)$$

$$Y_r = \pm \left[\frac{ct' E \Sigma x ds / h}{\Sigma G x^2} \right] \quad (155)$$

$$Z_r = \pm \left[\frac{ct' E \Sigma ds / h}{\Sigma G} \right] \quad (156)$$

These equations express the values of the redundants due to a difference in temperature between the upper and lower fibers of the arch rib.

When the upper fibers are at a higher temperature, the distortion of the residual cantilever will obviously be in the same direction as that induced by a vertical loading. Hence the redundant forces will act in the same direction as for vertical loading. When the upper fibers are at a lower temperature than that of the lower fibers, the reverse is true.

20. Stresses Due to Rib Shortening or Axial Thrust.—In Art. 15, p. 445, the terms $\frac{n_x ds}{AE}$, $\frac{n_x n_y ds}{AE}$, etc. were dropped from the elastic equations (see Eqs. (105) to (107) inclusive). While this is perfectly permissible when considering the effect of gravity loadings and of temperature, it involves large errors when considering the effect of axial distortions. We must therefore develop the expressions for the redundants due to axial thrust directly from Eqs. (102) to (104) inclusive.

With the terminal point of the rigid bracket system located at the elastic center and with the redundant axes properly “conjugated”

$$\left. \begin{aligned} \sum \frac{m_x m_y ds}{EI} \\ \sum \frac{m_x m_x ds}{EI} \\ \sum \frac{m_y m_x ds}{EI} \end{aligned} \right\} = 0$$

For rigid supports, and neglecting all temperature terms and terms involving the moments M_o (since the effect of the thrusts N alone is now desired), we may write Eq. (102) as follows:

$$\sum \frac{N_o n_x ds}{AE} = - \left[X \sum \frac{(m_x)^2 ds}{EI} + X \sum \frac{(n_x)^2 ds}{AE} + Y \sum \frac{n_x n_y ds}{AE} + Z \sum \frac{n_x n_x ds}{AE} \right] = - \left[X \sum \frac{(m_x)^2 ds}{EI} + \sum (X n_x + Y n_y + Z n_z) \left(\frac{n_x ds}{AE} \right) \right] \quad (157)$$

$$X = \frac{-\Sigma(N_o + X n_x + Y n_y + Z n_z) \frac{n_x ds}{AE}}{\sum \frac{(m_x)^2 ds}{EI}} \quad (158)$$

But from Eq. (101)

$$N_o + X n_x + Y n_y + Z n_z = N \quad (159)$$

Whence

$$X_N = \frac{-E \sum \frac{N n_x ds}{AE}}{\cos \phi^2 \Sigma G y^2} \quad (160)$$

In a similar manner

$$Y_N = \frac{E \sum \frac{N n_y ds}{AE}}{\Sigma G x^2} \quad (161)$$

$$Z_N = \frac{E \sum \frac{N n_z ds}{AE}}{\Sigma G} = 0 \text{ (since } n_z = 0) \quad (162)$$

It will be noted that these equations are in exactly the same form as those representing the effect of a uniform change in temperature if we substitute $\frac{N}{A}$ for Ect . In other words, the stresses due to the effect of the axial thrust are equal to those produced by a temperature drop of t'' degrees where

$$t'' = \frac{N}{AEc} \tag{163}$$

In this manner the axial effects may be regarded in the light of an "equivalent temperature drop" and solved from the temperature stresses by direct proportion. These stresses are generally designated by the term "rib shortening" stresses.

21. Symmetrical Arch Ribs.—If the arch rib is symmetrical about the center line of the span, it is obvious that the "elastic center" will fall on a vertical through this center line. It is only necessary therefore to

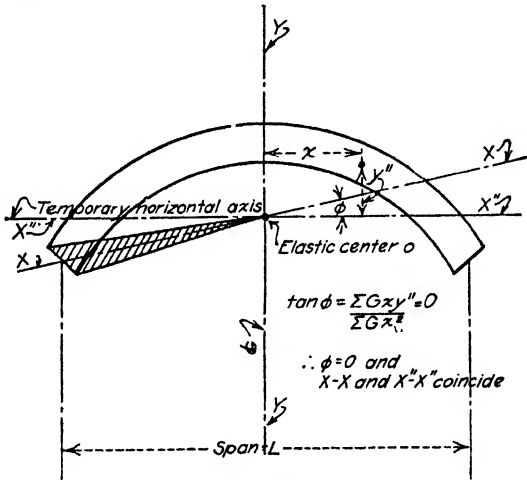

FIG. 34.

locate the vertical position of the elastic center on this center line, which may be done by applying the elastic weights horizontally as discussed in the next chapter.

Consider the symmetrical arch span shown in Fig. 34, with the elastic center O determined as above. Through this elastic center construct the vertical redundant axis $Y-Y$ and a temporary horizontal axis $X''-X''$.

The true conjugate axis $X-X$ (from Eq. (122)) makes some angle ϕ with the axis $X''-X''$ such that

$$\tan \phi = \frac{\sum Gxy''}{\sum Gx^2} \tag{164}$$

But, since the arch is symmetrical, $\sum Gxy''$ must equal zero, whence $\tan \phi = 0$, $\phi = 0$, and the axes $X''-X''$ and $X-X$ coincide. For symmetrical

arch ribs, therefore, the conjugate axes are at right angles, which simplifies the equations for determination of the redundants.

We may therefore rewrite the redundant equations in the foregoing articles to apply to symmetrical arches as follows:

Case I—Unit Load at Any Point g (see Eqs. (130) to (132) inclusive).

$$X_o = - \frac{\Sigma'_j kGy}{\Sigma Gy^2} \quad (165)$$

$$Y_o = \frac{\Sigma'_j kGx}{\Sigma Gx^2} \quad (166)$$

$$Z_o = \frac{\Sigma'_j kG}{\Sigma G} \quad (167)$$

Case II—Uniform Change in Temperature.—(Note that for a symmetrical rib $L' = L$ and $L'' = 0$.)

$$X_t = \pm \left[\frac{EctL}{\Sigma Gy^2} \right] \quad (168)$$

$$Y_t \text{ and } Z_t = 0 \quad (169)$$

Case III—Effect of Variable Temperature Change.

$$X_v = \pm \left[\frac{ct'E \Sigma yds/h}{\Sigma Gy^2} \right] \quad (170)$$

$$Y_v = \pm \left[\frac{ct'E \Sigma xds/h}{\Sigma Gx^2} \right] \quad (171)$$

$$Z_v = \pm \left[\frac{ct'E \Sigma ds/h}{\Sigma G} \right] \quad (172)$$

COMPLETE ANALYSIS OF A 350-FT. FIXED STEEL ARCH RIB

The calculations given below are taken from the preliminary analysis of the 350-ft. encased steel arch rib designed to span the Willamette River at Oregon City, Ore.

Figure 35 indicates the general dimensions and make-up of the structural ribs as first assumed, the span being a "half through" type consisting of two box girder arch ribs of 350-ft. center line span and 100-ft. rise. The structure is encased in concrete and supports a reinforced concrete deck carrying a 20-ft. roadway and two 5-ft. sidewalks. The arch rib is fixed at the skewbacks and sprung from solid basalt cliffs.

The analysis considers only the structural steel rib, the concrete encasement being considered merely as a protective covering. The procedure is as follows:

OPERATION I

The arch rib was first sketched in with roughly assumed dimensions, the dead loads at each panel point were calculated and an equilibrium polygon for such loading passed through the center line at crown and at

both skewbacks. The axial curve for the arch was then corrected to closely approximate this "trial polygon" and again sketched in. "Rough in" or preliminary stress calculations were then made and the assumptions as to the "make-up" of the rib at various points corrected accord-

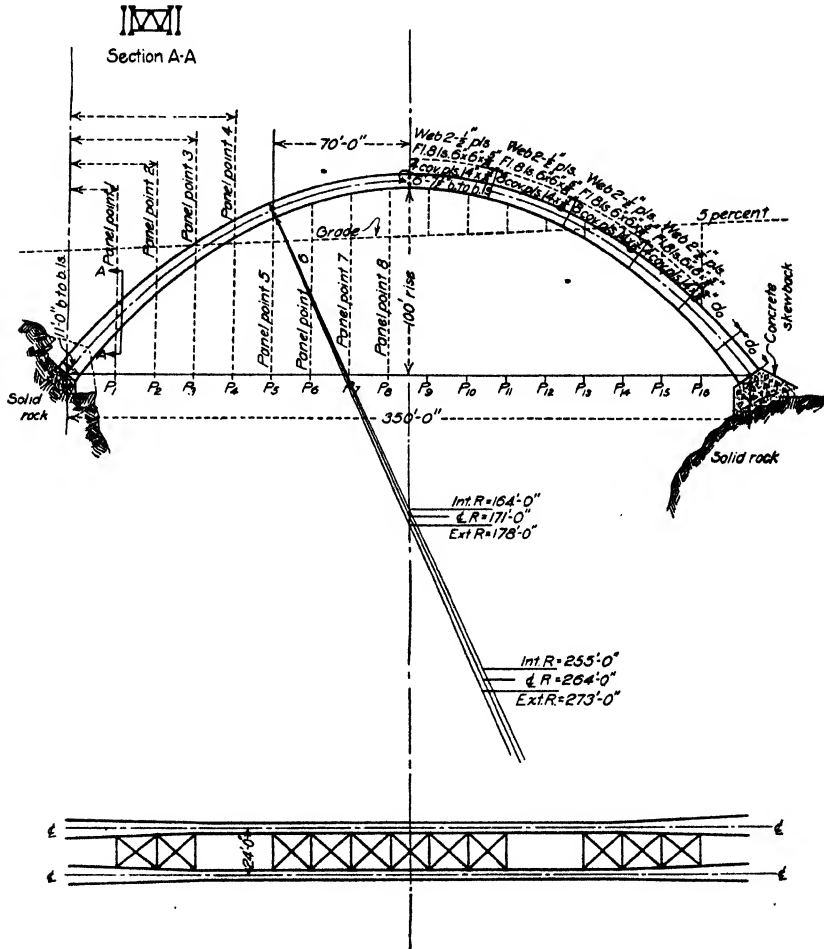

FIG. 35.

ingly. Figure 35 illustrates the dimensions and make-up of the rib at this stage of the work.

OPERATION II

The half rib was next divided into 16 equal linear increments ds (ds in this case = 156.4 in.) and the moment of inertia of the rib section at the center of each of these increments or "voussoirs" then computed. The calculations for this operation are given in Table 7.

OPERATION III

The elastic weights $G = \frac{m_z \tilde{d}s}{I} = \frac{ds}{I}$ (since $m_z = \text{unity}$) were next computed and the center of gravity of such elastic load system determined, thus locating the "elastic center" of the system. (Since the span is symmetrical this elastic center must lie on a vertical through the center line of the span.) The calculations for this operation are given in Table 8.

OPERATION IV

Next, for each section, or "voussoir," the terms $y, y^2, Gy, Gy^2, x, x^2, Gx$ and Gx^2 , also the summations $\Sigma G, \Sigma Gx^2$, and ΣGy^2 were computed (see Table 9). With these terms the equilibrium polygons for the load lines $\Sigma G, \Sigma Gx$ and ΣGy , were next constructed, thus determining the influence diagrams for the redundants X, Y , and Z , acting at the elastic center of the system (see Fig. 36A). The values of these redundants for a unit moving load were scaled from these influence diagrams and are tabulated for use in Table 10. It will be noted that for ease in plotting the pole distances have been taken as follows:

- For redundant Z , pole distance = $2\Sigma G$
- For redundant X , pole distance = $\Sigma Gy^2 \div 500$
- For redundant Y , pole distance = $\Sigma Gx^2 \div 1,000$

The influence line ordinates therefore measure to the scale of the drawing the values $\frac{1}{2}Z, 500X$ and $1,000Y$.

OPERATION V

With the X, Y and Z influence lines plotted, it now becomes necessary to plot influence lines for the moment M , and axial thrust T at any point. The calculations for this work are given in Tables 11 to 19 inclusive and the influence diagrams in Fig. 36B. Moment and thrust influence lines being calculated for nine different points on the rib as shown.

OPERATION VI

The thrust X_t due to a temperature variation of 30 deg. each way from normal is next computed. (The structure, being located in the Willamette Valley, is not subjected to any large variation in external temperature, the winter seasons being very mild). Thirty degrees variation was, therefore, considered sufficient.

$$X_t = \pm \frac{EctL}{\Sigma Gy^2} = \pm \frac{(30,000,000)(0.000006)(30)(4,200)}{2,191}$$

$$M_t = \pm X_t y$$

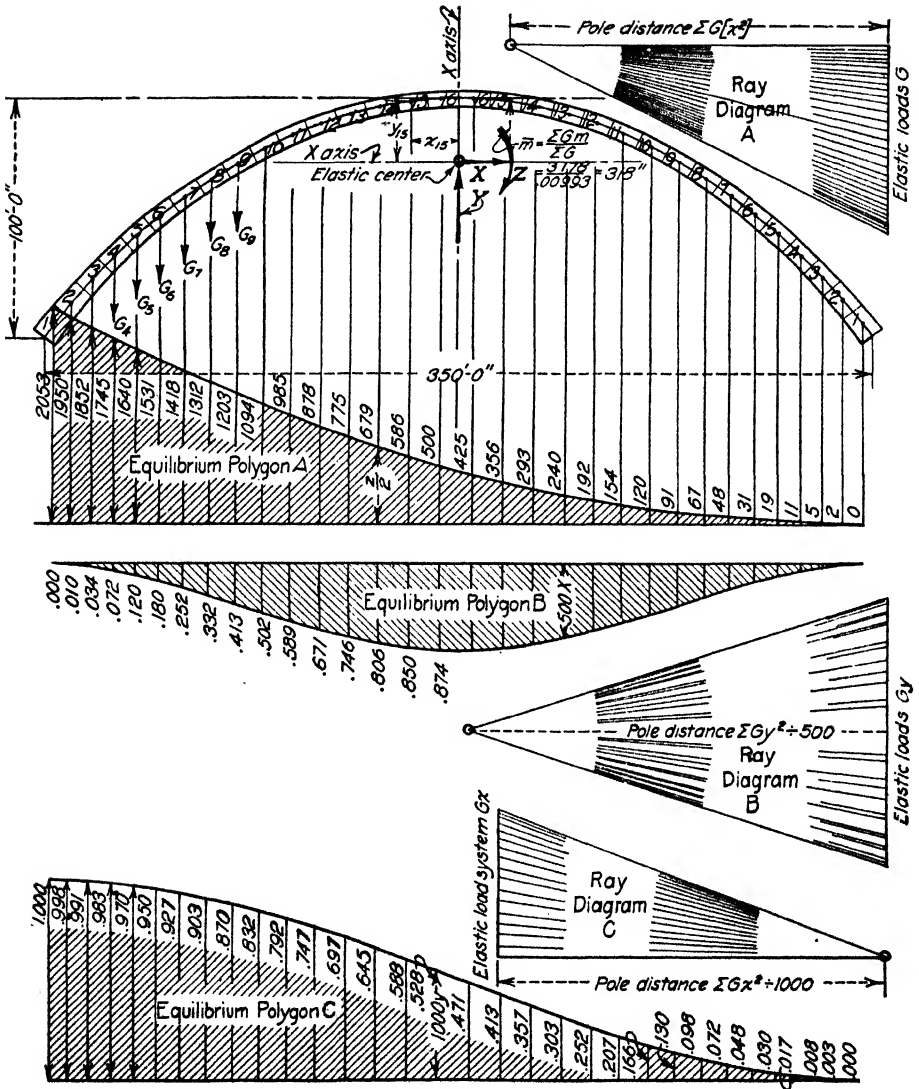

Influence Lines for Moment and Thrust

FIG. 36A.

ANALYSIS OF FIXED ARCHES

OPERATION VII

The dead and live load panel point concentrations are next computed. The detail calculations for dead loadings are not given here the results are readily computed as follows:

For the truck in the position shown the concentrations are: 18,800 lb. at A, 38,400 lb. at B, 18,800 lb. at C, and 20,000 lb. at D. In addition

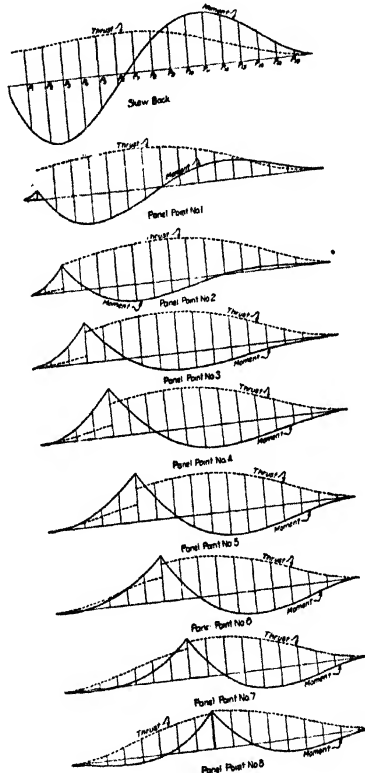

FIG. 36B.

to this live loading the concentrations from live load on the sidewalks amount to 10,800 lb. per panel for panels No. 3 to No. 13 inclusive. For the other panels the sidewalk is not so wide and the live loading amounts to but 6,000 lb. per panel.

OPERATION VIII

Having the live and dead load concentrations computed, the same are now applied to the influence diagram and the resulting moments and

thrusts calculated therefrom. With these moments and thrusts the stresses in the material are calculated by the ordinary formulas. The detail work for this last operation is given in Tables 20 to 28 inclusive. This completes the principal features of the preliminary analysis. It will be noted that the stresses at every point except the skewback are within the usual allowable limits indicating that the skewback section should be increased for the final analysis.

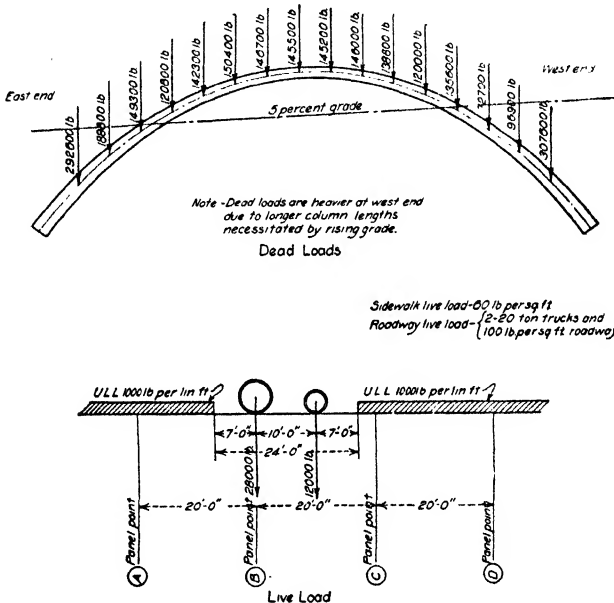

FIG. 37.

OPERATION IX

The only other stresses remaining to be determined are the "rib shortening" stresses and those resulting from a variable change in internal temperature. The former stresses are obtained from the temperature stresses simply by direct proportion as was discussed in the preceding chapter. The effect of a variable temperature change may be determined from the application of the formulas discussed in Art. 21, p. 454 (see Eqs. (170) to (172) inclusive). Neither of these conditions was considered in the preliminary design hereinabove described. The method of obtaining them for the final analysis having been explained in a former chapter, is not given here.

In addition to the above stresses, there will, of course, be certain wind stresses in the rib, but these, being calculated by the ordinary static formulas, need not be discussed in this connection.

TABLE 7.—CALCULATIONS FOR MOMENT OF INERTIA OF RIB SECTION

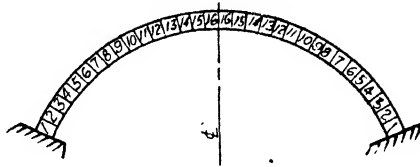

Section	Depth "d" b.f.fl. is	Make up	Moment of inertia (Big. inches)
1	129"	Web 2 PIs 1/2" x 129" Flange { 8 Ls 6" x 6" x 5/8" 4 Cov. PIs 14" x 3/8"	$129^3 \div 12 = 178800$ $(77.9)(63.3)^2 + 200 = 312000$ <u>490800</u>
2	124"	Web 2 PIs 1/2" x 124" Flange { 8 Ls 6" x 6" x 5/8" 4 Cov. PIs 14" x 3/8"	$124^3 \div 12 = 158900$ $77.9 \div 0.8^2 + 200 = 288400$ <u>447300</u>
3	119"	Web 2 PIs 1/2" x 119" Flange { 8 Ls 6" x 6" x 5/8" 4 Cov. PIs 14" x 3/8"	$119^3 \div 12 = 140400$ $(77.9)(58.3)^2 + 200 = 265100$ <u>405500</u>
4	114"	Web 2 PIs 1/2" x 114" Flange { 8 Ls 6" x 6" x 5/8" 4 Cov. PIs 14" x 3/8"	$114^3 \div 12 = 123400$ $(77.9)(55.8)^2 + 200 = 242600$ <u>366000</u>
5	109"	Web 2 PIs 1/2" x 109" Flange { 8 Ls 6" x 6" x 5/8" 4 Cov. PIs 14" x 3/8"	$109^3 \div 12 = 107900$ $(77.9)(53.3)^2 + 200 = 221500$ <u>329400</u>
6	105"	Web 2 PIs 1/2" x 105" Flange { 8 Ls 6" x 6" x 5/8" 4 Cov. PIs 14" x 3/8"	$105^3 \div 12 = 96400$ $(77.9)(51.3)^2 + 200 = 205100$ <u>301500</u>
7	101"	Web 2 PIs 1/2" x 101" Flange { 8 Ls 6" x 6" x 5/8" 4 Cov. PIs 14" x 3/8"	$101^3 \div 12 = 85900$ $(77.9)(49.3)^2 + 200 = 189500$ <u>275400</u>
8	97"	Web 2 PIs 1/2" x 97" Flange { 8 Ls 6" x 6" x 5/8" 4 Cov. PIs 14" x 3/8"	$97^3 \div 12 = 76000$ $(77.9)(47.3)^2 + 200 = 174800$ $(21.0)(49.1)^2 = 50700$ <u>301500</u>
9	93"	Web 2 PIs 1/2" x 93" Flange { 8 Ls 6" x 6" x 5/8" 4 Cov. PIs 14" x 3/8"	$93^3 \div 12 = 67000$ $(77.9)(45.3)^2 + 200 = 159000$ $(21.0)(47.1)^2 = 46700$ <u>272700</u>
10	90"	Web 2 PIs 1/2" x 90" Flange { 8 Ls 6" x 6" x 5/8" 4 Cov. PIs 14" x 3/8"	$90^3 \div 12 = 60800$ $(77.9)(43.8)^2 + 200 = 149800$ $(21.0)(45.6)^2 = 41700$ <u>254300</u>
11	87"	Web 2 PIs 1/2" x 87" Flange { 8 Ls 6" x 6" x 5/8" 4 Cov. PIs 14" x 3/8"	$87^3 \div 12 = 55000$ $(77.9)(42.3)^2 + 200 = 139700$ $(21.0)(44.7)^2 = 40800$ <u>235500</u>
12	84"	Web 2 PIs 1/2" x 84" Flange { 8 Ls 6" x 6" x 5/8" 4 Cov. PIs 14" x 3/8"	$84^3 \div 12 = 49400$ $(77.9)(40.8)^2 + 200 = 129800$ $(21.0)(42.6)^2 = 38100$ <u>217300</u>
13	82"	Web 2 PIs 1/2" x 82" Flange { 8 Ls 6" x 6" x 5/8" 4 Cov. PIs 14" x 3/8"	$82^3 \div 12 = 45900$ $(77.9)(39.8)^2 + 200 = 123500$ <u>169400</u>
14	81"	Web 2 PIs 1/2" x 81" Flange { 8 Ls 6" x 6" x 5/8" 4 Cov. PIs 14" x 3/8"	$81^3 \div 12 = 44200$ $(77.9)(39.3)^2 + 200 = 120400$ <u>164600</u>
15	80"	Web 2 PIs 1/2" x 80" Flange { 8 Ls 6" x 6" x 5/8" 4 Cov. PIs 14" x 3/8"	$80^3 \div 12 = 42700$ $(77.9)(38.8)^2 + 200 = 117400$ <u>160100</u>
16	79"	Web 2 PIs 1/2" x 79" Flange { 8 Ls 6" x 6" x 5/8" 4 Cov. PIs 14" x 3/8"	$79^3 \div 12 = 41100$ $(77.9)(38.3)^2 + 200 = 114300$ <u>155400</u>

TABLE 8.—CALCULATIONS FOR POSITION OF "ELASTIC CENTER" OF ARCH SYSTEM

Section Voussoir No.	I (Big. inches)	$G = \frac{ds}{I}$	m (inches)	mG
1	490800	0.000319	1138	0.363
2	447300	.000349	1016	.354
3	405500	.000386	900	.347
4	366000	.000428	789	.338
5	329400	.000475	684	.325
6	301500	.000519	584	.303
7	275400	.000568	490	.278
8	301500	.000519	402	.209
9	272700	.000574	321	.184
10	254300	.000615	247	.152
11	235500	.000665	179	.119
12	217300	.000720	121	.087
13	169400	.000924	73	.067
14	164600	.000950	38	.036
15	160100	.000977	14	.014
16	155400	.001005	2	.002
Σ		.009993		3.178

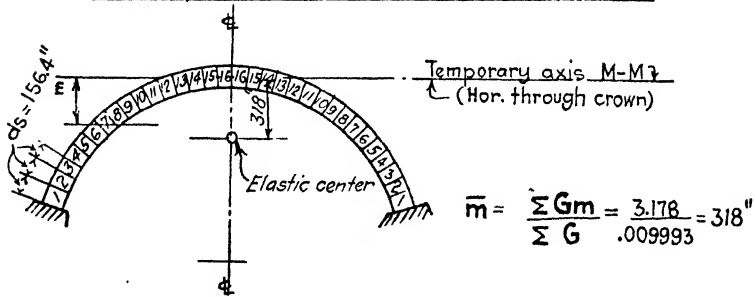

$$\bar{m} = \frac{\sum Gm}{\sum G} = \frac{3.178}{.009993} = 318"$$

TABLE 9.—CALCULATIONS FOR FACTORS EVALUATING REDUNDANTS

Section of Vessel No.	y (inches)	y ²	Gy	Gy ²	x (inches)	x ²	Gx	Gx ²
1	- 820	672400	- .2613	214.8	2053	4 200 000	0.654	1340
2	- 698	487204	- .2433	170.0	1954	3 820 000	.681	1333
3	- 582	339724	- .2246	130.8	1850	3 420 000	.714	1320
4	- 471	221841	- .2016	94.9	1740	3 030 000	.745	1297
5	- 366	133956	- .1738	63.3	1624	2 640 000	.771	1254
6	- 266	70756	- .1380	36.7	1503	2 260 000	.780	1174
7	- 172	29584	- .0876	16.8	1378	1 895 000	.782	1078
8	- 84	7056	- .0436	3.7	1248	1 560 000	.646	809
9	- 3	9	- .0017	0.1	1115	1 240 000	.640	712
10	+ 71	5041	+ .0436	3.1	977	954 529	.601	587
11	+ 139	19321	+ .0925	12.9	835	697 225	.555	463
12	+ 197	38809	+ .1420	27.9	690	476 100	.497	343
13	+ 245	60025	+ .2264	55.5	541	292 681	.500	271
14	+ 280	78400	+ .2660	74.5	389	151 321	.370	144
15	+ 304	92416	+ .2970	90.3	234	54 756	.229	53
16	+ 316	99856	+ .3180	100.3	78	6 084	.078	6
Σ			.0000	1095.6			9.243	12184

TABLE 10.—VALUES OF INFLUENCE LINE ORDINATES (SCALED FROM FIG. 36)

Unit load at Section No.	X (lb.)	Y (lb.)	Z (in. lb.)
1	0.000	1.000	2053
2	.010	0.998	1950
3	.034	.991	1852
4	.072	.983	1745
5	.120	.970	1640
6	.180	.950	1531
7	.252	.929	1418
8	.332	.903	1312
9	.413	.870	1203
10	.502	.832	1094
11	.589	.792	985
12	.671	.747	878
13	.746	.697	775
14	.806	.645	679
15	.850	.588	586
16	.874	.528	500
16	.874	.471	425
15	.850	.413	356
14	.806	.357	293
13	.746	.303	240
12	.671	.252	192
11	.589	.207	154
10	.502	.166	120
9	.413	.130	91
8	.332	.098	67
7	.252	.072	48
6	.180	.048	31
5	.120	.030	19
4	.072	.017	11
3	.034	.008	5
2	.010	.003	2
1	.000	.000	0

TABLE 11.—INFLUENCE LINE ORDINATES FOR MOMENT THRUST (SKEW BACK)

Section or Voussoir	Moment (in. lb)				Thrust (lb.)		
	Xy	Yx	Z	M	Xcosθ	Ysinθ	T
1	0.0	2100	2053	-47	0.000	0.807	0.807
2	8.8	2095	1950	-136	.006	.805	.811
3	30.0	2080	1852	-198	.020	.800	.820
4	63.5	2065	1745	-256	.043	.793	.836
5	106.0	2036	1640	-290	.071	.782	.853
6	159.0	1995	1531	-305	.106	.766	.872
7	222.0	1950	1418	-310	.149	.749	.898
8	293.0	1896	1312	-291	.196	.728	.924
9	364.0	1827	1203	-260	.244	.701	.945
10	443.0	1747	1094	-210	.296	.671	.967
11	519.0	1664	985	-160	.348	.639	.987
12	592.0	1568	878	-98	.396	.602	.998
13	658.0	1463	775	-30	.440	.562	1.002
14	711.0	1354	679	+36	.476	.520	.996
15	750.0	1235	585	+101	.502	.474	.976
16	770.0	1110	500	+160	.515	.426	.941
16	770.0	990	425	+205	.515	.380	.895
15	750.0	866	356	+240	.502	.333	.835
14	711.0	750	293	+254	.476	.288	.763
13	658.0	636	240	+262	.440	.244	.684
12	592.0	529	192	+255	.396	.203	.599
11	519.0	435	154	+238	.348	.167	.515
10	443.0	349	120	+214	.296	.134	.430
9	364.0	273	91	+182	.244	.105	.349
8	293.0	206	67	+154	.196	.079	.275
7	222.0	151	48	+119	.149	.058	.207
6	159.0	101	31	+89	.106	.039	.145
5	106.0	63	19	+62	.071	.024	.095
4	63.5	35.7	11	+39	.043	.014	.067
3	30.0	17	5	+18	.020	.007	.027
2	8.8	6.3	2	+4	.006	.002	.008
1	0.0	0.0	0	0	.000	.000	.000

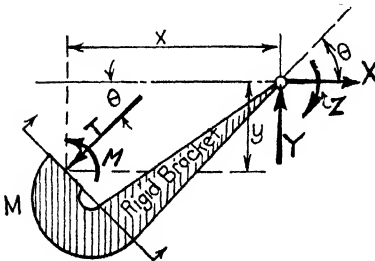

$y = 882''$
 $x = 2100''$
 $\cos \theta = 0.590$
 $\sin \theta = 0.807$

$M = Xy + Z - Yx$
 $T = X \cos \theta + Y \sin \theta$

TABLE 12.—INFLUENCE LINE ORDINATES FOR MOMENT AND THRUST (PANEL POINT No. 1)

Section or Voussoir No.	Moment (in:lb.)					Thrust (lb)			
	P _a	Xy	Y _x	Z	M	Xcosθ	Ysinθ	Psinθ	T
1	253	0	1800	2053	0	0.000	0.715	0.715	0.000
2	154	5	1796	1950	+ 5	.007	.714	.715	.006
3	50	18	1784	1852	+36	.024	.709	.715	.018
4		38	1768	1745	+ 15	.051	.702		.753
5		63	1746	1640	-43	.084	.693		.777
6		95	1710	1531	-84	.126	.679		.805
7		133	1670	1418	-119	.176	.664		.840
8		176	1624	1312	-136	.232	.645		.877
9		219	1565	1203	-143	.289	.622		.911
10		265	1497	1094	-138	.351	.595		.946
11		311	1424	985	-128	.412	.566		.978
12		355	1344	878	-111	.470	.534		1.004
13		395	1254	775	-84	.522	.498		1.020
14		427	1160	679	-54	.564	.461		1.025
15		450	1059	586	-23	.594	.420		1.014
16		462	950	500	+12	.611	.378		.989
16		462	848	425	+39	.611	.337		.948
15		450	744	356	+62	.594	.295		.894
14		427	642	293	+78	.564	.255		.819
13		395	545	240	+90	.522	.216		.738
12		355	453	192	+94	.470	.180		.650
11		311	373	154	+92	.412	.148		.560
10		265	299	120	+86	.351	.119		.470
9		219	234	91	+76	.289	.093		.382
8		176	176	67	+67	.232	.070		.302
7		133	130	48	+51	.176	.052		.228
6		95	86	31	+40	.126	.034		.160
5		63	54	19	+28	.084	.021		.105
4		38	31	11	+18	.051	.012		.063
3		18	14	5	+9	.024	.006		.030
2		5	5	2	+2	.007	.002		.009
1		0	0	0	0	.000	.000		.000

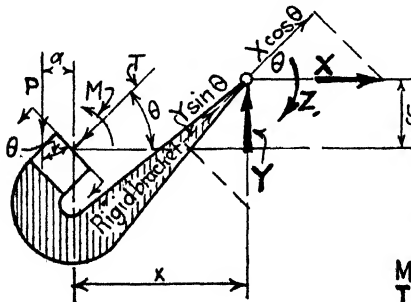

$x = 1800''$
 $y = 529''$
 $\cos \theta = 0.699$
 $\sin \theta = 0.715$
 $P = 1.0$
 $M = Xy + Z - Yx - P_a$
 $T = X \cos \theta + Y \sin \theta - P \sin \theta$

TABLE 13.—INFLUENCE LINE ORDINATES FOR MOMENT AND THRUST (PANEL POINT No. 2)

Section or Voussoir No.	Moment (in.-lb.)					Thrust (lb.)			
	Pa	Xy	Yx	Z	M	Xcosθ	Ysinθ	Psinθ	T
1	493	0	1560	2053	+ 0	0.000	0.635	0.635	0.000
2	394	3	1558	1950	+ 1	.008	.634	.635	.007
3	290	11	1546	1852	+ 27	.026	.630	.635	.021
4	180	22	1533	1745	+ 54	.056	.624	.635	.045
5	64	37	1513	1640	+ 100	.093	.616	.635	.074
6		56	1481	1531	+ 106	.139	.603		.742
7		78	1448	1418	+ 48	.195	.590		.785
8		103	1410	1312	+ 5	.257	.573		.830
9		128	1369	1203	- 28	.319	.552		.871
10		155	1298	1094	- 49	.388	.528		.916
11		183	1236	985	- 68	.455	.503		.958
12		208	1165	878	- 79	.519	.474		.992
13		231	1087	775	- 81	.577	.442		1.019
14		250	1006	679	- 77	.623	.410		1.033
15		263	917	586	- 68	.657	.374		1.031
16		271	824	500	- 53	.675	.335		1.010
16		271	735	425	- 33	.675	.299		.974
15		263	645	356	- 26	.657	.262		.919
14		250	557	293	- 14	.623	.227		.850
13		231	472	240	- 1	.577	.192		.769
12		208	393	192	+ 7	.519	.160		.679
11		183	323	154	+ 14	.455	.131		.586
10		155	259	120	+ 16	.388	.106		.494
9		128	203	91	+ 16	.319	.083		.402
8		103	153	67	+ 17	.257	.062		.319
7		78	112	48	+ 14	.195	.046		.241
6		56	75	31	+ 12	.139	.031		.170
5		37	47	19	+ 9	.093	.019		.112
4		22	27	11	+ 6	.056	.011		.067
3		11	12	5	+ 3	.026	.005		.031
2		3	5	2	0	.008	.002		.010
1		0	0	0	0	.000	.000		.000

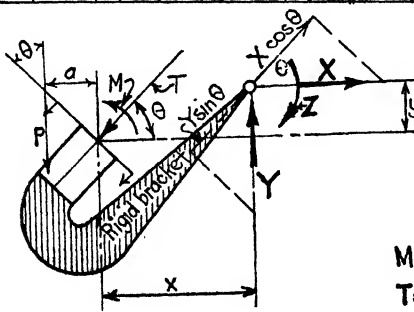

x = 1500"
 y = 310"
 cos θ = 0.773
 sin θ = 0.635
 P = W

$$M = Xy + Z - Yx - Pa$$

$$T = X \cos \theta + Y \sin \theta - P \sin \theta$$

TABLE 14.—INFLUENCE LINE ORDINATES FOR MOMENT AND THRUST (PANEL POINT No. 3)

Section or. No. or. No.	Moment (in.-lb.)					Thrust (lb.)			
	Pa	Xy	Yx	Z	M	Xcosθ	Ysinθ	Psinθ	T
1	733	0	1320	2053	0	.000	.562	.562	.000
2	634	1.3	1318	1950	-0.7	.008	.560	.562	.006
3	530	4.4	1309	1852	+17.4	.028	.557	.562	.023
4	420	9.3	1296	1745	+38.3	.060	.552	.562	.050
5	304	15.5	1280	1640	+71.5	.107	.545	.562	.080
6	183	23.2	1252	1531	+119.2	.149	.533	.562	.120
7	58	32.5	1224	1418	+168.5	.208	.521	.562	.167
8		42.8	1191	1312	+163.8	.275	.507		.782
9		53.3	1148	1203	+108.3	.341	.489		.830
10		64.7	1098	1094	+60.7	.415	.468		.883
11		76.0	1045	985	+16.0	.487	.445		.932
12		86.6	985	878	-20.4	.555	.420		.975
13		96.3	920	775	-48.7	.617	.392		1.009
14		104.0	851	679	-68.0	.667	.362		1.029
15		109.6	776	586	-80.4	.703	.330		1.033
16		112.6	696	500	-83.4	.722	.297		1.019
16		112.6	621	425	-83.4	.722	.265		.987
15		109.6	545	356	-78.4	.703	.232		.935
14		104.0	471	293	-74.0	.667	.201		.868
13		96.3	400	240	-63.7	.617	.170		.787
12		86.6	333	192	-54.4	.555	.142		.697
11		76.0	273	154	-43.0	.487	.116		.605
10		64.7	219	120	-34.3	.415	.093		.508
9		53.3	171	91	-26.7	.341	.073		.414
8		42.8	129	67	-19.2	.275	.055		.330
7		32.5	95	48	-15.5	.208	.040		.248
6		23.2	63	31	-8.8	.149	.027		.176
5		15.5	40	19	-5.5	.107	.017		.124
4		9.3	22	"	-1.7	.060	.010		.070
3		4.4	11	5	-1.6	.028	.004		.032
2		1.3	4	2	-0.7	.008	.002		.010
1		0.0	0	0	0.0	.000	.000		.000

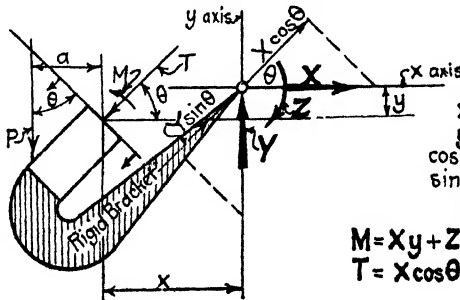

x = 1320"
 y = 129"
 cos θ = 0.827
 sin θ = 0.562
 P = 1.0

$$M = Xy + Z - Yx - Pa$$

$$T = X\cos\theta + Y\sin\theta - P\sin\theta$$

TABLE 15.—INFLUENCE LINE ORDINATES FOR MOMENT AND THRUST (PANEL POINT No. 4)

Section or Voussoir No.	Moment (in-lb)					Thrust (lb)			
	Pa	Xy	Yx	Z	M	Xcosθ	Ysinθ	Psinθ	T
1	973	0	1080	2053	0	0.000	0.485	0.485	0.000
2	874	0.2	1078	1850	-2.2	.009	.484	.485	.008
3	770	0.6	1071	1852	+10.4	.030	.481	.485	.026
4	660	1.3	1061	1745	+22.7	.063	.477	.485	.055
5	544	2.2	1047	1640	+46.8	.105	.470	.485	.090
6	423	3.2	1025	1531	+79.8	.158	.461	.485	.134
7	298	4.5	1003	1418	+112.5	.220	.451	.485	.186
8	168	6.0	975	1312	+163.0	.290	.438	.485	.243
9	35	7.4	940	1203	+220.6	.362	.422	.485	.299
10		9.0	898	1094	+187.0	.439	.403		.842
11		10.6	855	985	+119.4	.515	.384		.899
12		12.1	806	878	+59.9	.587	.362		.949
13		13.4	752	775	+9.6	.653	.338		.991
14		14.5	696	679	-31.5	.705	.313		1.018
15		15.3	635	586	-64.3	.744	.287		1.031
16		15.7	570	500	-85.7	.765	.256		1.021
16		15.7	508	425	-98.1	.765	.228		.993
15		15.3	447	356	-106.3	.744	.200		.944
14		14.5	386	293	-107.5	.705	.173		.878
13		13.4	327	240	-100.4	.653	.147		.800
12		12.1	272	192	-92.1	.587	.122		.709
11		10.6	224	154	-80.6	.515	.101		.616
10		9.0	179	120	-68.0	.439	.081		.520
9		7.4	140.6	91	-57.0	.362	.063		.425
8		6.0	106.0	67	-45.0	.290	.048		.338
7		4.5	77.7	48	-34.2	.220	.035		.255
6		3.2	51.8	31	-24.0	.158	.023		.181
5		2.2	32.4	19	-15.6	.105	.015		.120
4		1.3	18.3	11	-8.6	.063	.008		.071
3		0.6	8.6	5	-4.2	.030	.004		.034
2		0.2	3.2	2	-1.4	.009	.001		.010
1		0.0	0.0	0	0.0	.000	.000		.000

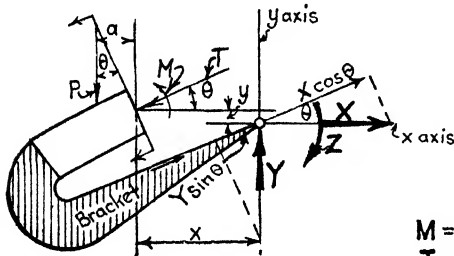

$x = 1080''$
 $y = 18''$
 $\cos \theta = 0.875$
 $\sin \theta = 0.485$
 $P = 1.0$

$M = Z - Xy - Yx - Pa$
 $T = X\cos\theta + Y\sin\theta - P\sin\theta$

TABLE 16.—INFLUENCE LINE ORDINATES FOR MOMENT AND THRUST (PANEL POINT No. 5)

Section or Voussoir	Moment (in.-lb.)					Thrust (lb.)			
	Pa	Xy	Yx	Z	M	Xcosθ	Ysinθ	Psinθ	T
1	1213	0.0	840	2053	0	0.000	0.409	0.409	0.000
2	1114	1.4	838	1950	-3.4	.009	.408	.409	.008
3	1010	4.7	834	1852	+3.3	.031	.406	.409	.028
4	900	9.9	826	1745	+9.1	.066	.402	.409	.059
5	784	16.6	815	1640	+24.4	.109	.397	.409	.097
6	653	24.9	799	1531	+44.1	.164	.389	.409	.144
7	538	34.8	780	1418	+65.2	.230	.380	.409	.201
8	408	45.8	758	1312	+100.2	.302	.369	.409	.262
9	275	57.0	731	1203	+140.0	.376	.356	.409	.323
10	137	69.2	698	1094	+189.8	.457	.340	.409	.398
11		81.2	666	985	+237.8	.536	.324		.860
12		92.6	628	878	+287.4	.612	.306		.918
13		103.0	586	775	+338.0	.680	.283		.963
14		111.0	542	679	+389.0	.735	.264		.999
15		117.0	494	586	-25.0	.775	.241		1.016
16		120.0	444	500	-64.0	.795	.216		1.011
16		120.0	396	425	-91.0	.795	.193		.988
15		117.0	347	356	-108.0	.775	.169		.944
14		111.0	300	293	-118.0	.735	.146		.881
13		103.0	255	240	-118.0	.680	.124		.804
12		92.6	222	192	-112.6	.612	.103		.715
11		81.2	174	154	-101.2	.536	.085		.621
10		69.2	140	120	-89.2	.457	.068		.525
9		57.0	109	91	-75.0	.376	.053		.429
8		45.8	82.3	67	-61.1	.302	.040		.342
7		34.8	60.5	48	-47.3	.230	.029		.259
6		24.9	40.4	31	-34.3	.164	.020		.184
5		16.6	25.2	19	-22.8	.109	.012		.121
4		9.9	14.3	11	-12.3	.066	.007		.073
3		4.7	6.7	5	-6.4	.031	.003		.034
2		1.4	2.5	2	-1.9	.009	.001		.010
1		0.0	0.0	0	0.0	.000	.000		.000

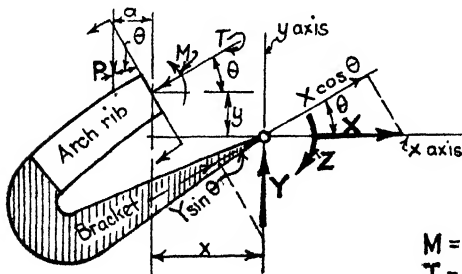

x = 840"
 y = 138"
 cos θ = 0.912
 sin θ = 0.409
 P = 1.0

$$M = Z - Xy - Yx - Pa$$

$$T = Xcosθ + Ysinθ - Psinθ$$

TABLE 17.—INFLUENCE LINE ORDINATES FOR MOMENT AND THRUST (PANEL POINT No. 6)

Section of Voussoir No.	Moment (in.-lb)					Thrust (lb)			
	Pa	Xy	Yx	Z	M	Xcosθ	Ysinθ	Psinθ	T
1	1453	0	600	2053	0	0.000	0.292	0.292	0.000
2	1354	2.3	599	1950	-5.3	.010	.291	.292	.009
3	1250	7.8	595	1852	-0.8	.033	.289	.292	.030
4	1140	16.5	590	1745	-1.5	.069	.287	.292	.064
5	1024	27.5	582	1640	+6.5	.115	.283	.292	.106
6	903	41.2	570	1531	+16.8	.172	.277	.292	.157
7	778	57.7	558	1418	+24.3	.241	.271	.292	.220
8	648	76.6	542	1312	+46.0	.318	.263	.292	.289
9	515	94.5	522	1203	+71.5	.395	.254	.292	.357
10	377	115.0	499	1094	+103.0	.480	.243	.292	.431
11	239	135.0	476	985	+135.0	.563	.231	.292	.502
12	90	156.0	448	878	+184.0	.642	.218	.292	.568
13		171.0	4.8	775	+186.0	.714	.203		.917
14		185.0	3.97	679	+107.0	.771	.188		.959
15		195.0	3.53	586	+38.0	.813	.172		.985
16		200.0	3.17	500	-17.0	.835	.154		.989
16		200.0	2.83	425	-58.0	.835	.137		.972
15		195.0	2.48	356	-87.0	.813	.121		.934
14		185.0	2.14	293	-106.0	.771	.104		.875
13		171.0	1.82	240	-113.0	.714	.089		.803
12		156.0	1.51	192	-115.0	.642	.074		.716
11		135.0	1.24	154	-105.0	.563	.060		.623
10		115.0	99.6	120	-94.6	.380	.049		.529
9		94.5	78.0	91	-81.5	.395	.038		.433
8		76.0	58.8	67	-67.8	.318	.029		.347
7		57.7	43.2	48	-57.9	.241	.021		.262
6		41.2	28.8	31	-39.0	.172	.014		.186
5		27.5	18.0	19	-26.5	.115	.009		.124
4		16.5	10.2	11	-15.7	.069	.005		.074
3		7.8	4.8	5	-7.6	.033	.002		.035
2		2.3	1.8	2	-2.1	.010	.001		.011
1		0.0	0.0	0	0.0	.000	.000		.000

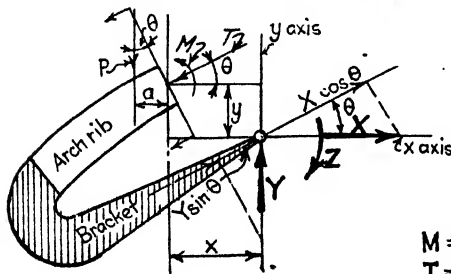

$x = 600''$
 $y = 229''$
 $\cos \theta = 0.956$
 $\sin \theta = 0.292$
 $P = 1.0$

$M = Z - Xy - Yx - Pa$
 $T = X \cos \theta + Y \sin \theta - P \sin \theta$

TABLE 18.—INFLUENCE LINE ORDINATES FOR MOMENT AND THRUST (PANEL POINT No. 7)

Section or Voussoir No.	Moment (in.-lb)					Thrust (lb)			
	Pa	Xy	Yx	Z	M	Xcosθ	Ysinθ	Psinθ	T
1	1693	0	360	2053	0	0.000	0.175	0.175	0.000
2	1594	2.9	349	1950	-5.9	.010	.175	.175	.010
3	1490	9.8	357	1852	-4.8	.033	.174	.175	.032
4	1380	20.7	354	1745	-9.7	.071	.172	.175	.068
5	1264	34.6	34.9	1640	-7.6	.118	.170	.175	.113
6	1143	51.9	342	1531	-5.9	.177	.166	.175	.168
7	1018	72.6	334	1418	-6.6	.248	.162	.175	.235
8	888	95.5	325	1312	+3.5	.327	.158	.175	.310
9	755	119.0	313	1203	+16.0	.406	.152	.175	.383
10	617	145.0	300	1094	+32.0	.494	.146	.175	.465
11	475	170.0	285	985	+55.0	.580	.139	.175	.544
12	330	193.0	269	878	+86.0	.660	.131	.175	.616
13	181	215.0	251	775	+128.0	.735	.122	.175	.682
14	29	232.0	232	679	+186.0	.794	.113	.175	.732
15		245.0	211	586	+130.0	.836	.103		.939
16		251.0	190	500	+59.0	.860	.092		.952
16		251.0	170	425	+4.0	.860	.082		.942
15		245.0	149	356	-38.0	.836	.072		.908
14		232.0	128.5	293	-67.5	.794	.068		.862
13		215.0	109.0	240	-84.0	.735	.053		.788
12		193.0	90.6	192	-81.6	.660	.044		.704
11		170.0	74.5	154	-90.5	.580	.036		.616
10		145.0	59.8	120	-84.8	.494	.029		.523
9		119.0	46.8	91	-74.8	.406	.023		.429
8		95.5	35.3	67	-63.8	.327	.017		.344
7		72.6	25.9	48	-52.5	.248	.013		.261
6		51.9	17.3	31	-38.2	.177	.008		.185
5		34.6	10.8	19	-26.4	.118	.005		.123
4		20.7	6.1	11	-15.8	.071	.003		.074
3		9.8	2.9	5	-7.7	.033	.001		.034
2		2.9	1.1	2	-2.0	.010	.000		.010
1		0.0	0.0	0	0.0	.000	.000		.000

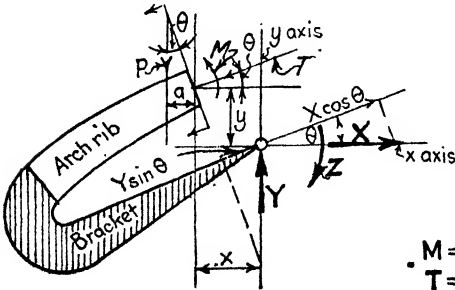

$x = 360'$
 $y = 288'$
 $\cos \theta = 0.984$
 $\sin \theta = 0.175$
 $P = 1.0$

$M = Z - Xy - Yx - Pa$
 $T = X \cos \theta + Y \sin \theta - P \sin \theta$

TABLE 19.—INFLUENCE LINE ORDINATES FOR MOMENT AND THRUST (PANEL POINT No. 8)

Section Noussair No	Moment (in.-lb.)					Thrust (lb)			
	Pa	Xy'	Yx	Z	M	Xcosθ	Ysinθ	Psinθ	T
1	1933	0	120.0	2053	0.0	0.000	0.058	0.058	0.000
2	1834	3.2	119.8	1950	-7.0	.010	.058	.058	.010
3	1730	10.7	119.0	1852	-7.7	.034	.058	.058	.034
4	1620	22.7	118.0	1745	-15.7	.072	.057	.058	.071
5	1504	37.8	116.4	1640	-18.2	.120	.056	.058	.118
6	1383	56.7	114.0	1531	-22.7	.180	.055	.058	.177
7	1258	79.5	111.3	1418	-30.8	.251	.054	.058	.247
8	1128	104.6	108.3	1312	-28.7	.331	.052	.058	.325
9	995	130.0	104.4	1203	-26.4	.412	.050	.058	.404
10	857	158.0	100.0	1094	-21.0	.501	.048	.058	.497
11	715	185.5	95.0	985	-10.5	.587	.046	.058	.575
12	570	211.0	89.6	878	+7.4	.669	.043	.058	.654
13	421	235.0	83.5	775	+35.5	.744	.040	.058	.726
14	269	254.0	77.4	679	+78.6	.804	.037	.058	.783
15	114	268.0	70.5	586	+133.5	.848	.034	.058	.824
16		275.0	63.4	500	+161.6	.872	.031		.903
16		275.0	56.5	425	+23.5	.872	.027		.899
15		268.0	49.6	356	+38.4	.848	.024		.872
14		254.0	42.8	293	-3.8	.804	.021		.825
13		235.0	36.4	240	-31.4	.744	.018		.762
12		211.0	30.2	192	-49.2	.669	.015		.684
11		185.5	24.8	154	-56.3	.587	.012		.599
10		158.0	19.9	120	-57.9	.501	.010		.511
9		130.0	15.6	91	-54.6	.412	.008		.420
8		104.6	11.8	67	-49.4	.331	.006		.337
7		79.5	8.6	48	-40.1	.251	.004		.255
6		56.7	5.8	31	-31.5	.180	.003		.183
5		37.8	3.6	19	-22.4	.120	.002		.122
4		22.7	2.0	11	-13.7	.072	.001		.073
3		10.7	1.0	5	-6.7	.034	.000		.034
2		3.2	0.4	2	-1.6	.010	.000		.010
1		0.0	0.0	0	0.0	.000	.000		.000

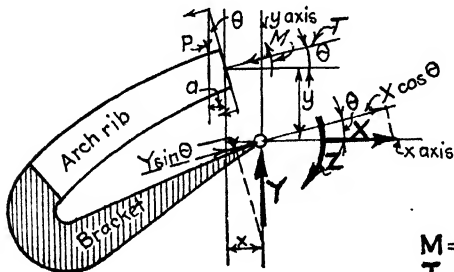

x = 120°
 y = 315°
 cos θ = 0.998
 sin θ = 0.058
 p = 1.0

$$M = Z \cdot Xy - Yx - Pa$$

$$T = X \cos \theta + Y \sin \theta - P \sin \theta$$

TABLE 20.—MOMENTS AND THRUSTS AT SKEW BACK

St. No.	Ordinates		Dead load concentrations (thousands lb.)	Live load concentrations (thousands lb.)	Maximum positive moment (thousands of in.-lb.)		Maximum negative moment (thousands of in.-lb.)		Thrust (thousands of lb.)		
	+	-			+	-	+	-	Ord.	For + Mom.	For - Mom.
1		228	292.6	26.0		65700		72600	.827	242.0	263.5
2		301	188.8	24.8		56800		64300	.866	163.4	185.0
3		302	149.3	49.2		45700		60000	.910	136.0	180.8
4		249	120.8	29.6		30100		37400	.948	114.4	142.4
5		161	142.3	30.8		22900		27900	.984	140.0	170.0
6		56	150.4	30.8		8400		10200	1.000	150.4	181.2
7	57		146.7	30.8	9100		7500		.990	175.7	145.0
8	147		145.5	30.8	25900		21400		.955	168.0	139.0
9	217		145.2	30.8	38200		31500		.877	154.4	127.4
10	256		146.0	29.6	45000		37400		.770	135.0	112.5
11	259		138.8	49.2	48700		35900		.646	121.4	89.6
12	234		120.0	29.6	35000		28100		.508	76.0	61.0
13	191		135.6	30.8	31800		25900		.370	61.5	50.2
14	134		172.7	26.0	26600		22100		.235	46.7	40.6
15	77		196.9	26.0	16400		15100		.120	25.6	23.6
16	27		307.6	26.0	9000		8300		.040	13.4	12.3
Total					285700	230000	233200	272400		1923.9	1924.1

Summary { Max. positive moment (285700 - 230000)(1000) = 55,700,000 # (Dead plus live)
 Thrust occurring for max. positive mom. condition 1,923,900 # (" " ")
 Max. negative moment (272400 - 233200)(1000) = 39,200,000 # (" " ")
 Thrust occurring for max. negative mom. condition 1,924,100 # (" " ")

For this section A = 210 ft.⁴
 I = 518970
 e = 66"

$$f_s = \frac{19239000 \pm 55700000 \times 66}{66} = 16260 \#/\text{in}^2 \text{ (Dead+live)}$$

Temperature stresses Moment = 103.50 # x 882" = 9,120,000 #
 Thrust = 103.50 # x 590 = 6,100 #
 $f_s = -\frac{9100}{210} \pm \frac{9,120,000 \times 66}{518970} = 1190 \#/\text{in}^2 \text{ (Temp)}$
 Total stress DL + LL + Temp = 17450 #/in²

TABLE 21.—MOMENTS AND THRUSTS AT PANEL POINT 1

Panel Point	Ordinates		Dead load concentration (thousands lb.)	Live load concentrations (thousands lb.)	Maximum positive moment (thousands of in.-lb.)		Maximum negative moment (thousands of in.-lb.)		Thrust (thousands of lb.)			
	+	-			+	-	+	-	Ord.	For + Mom.	For - Mom.	
1	42.0		292.6	26.0	13,500		12,250		.740	238.0	216.0	
2	64.0		188.8	26.0	12,100		13,760		.790	449.0	170.0	
3	127.5		149.3	29.6	13,000		22,800		.850	127.0	152.0	
4	142.0		120.8	49.2	17,200		24,200		.920	111.0	156.0	
5	130.0		142.3	29.6	18,500		22,400		.915	138.5	167.5	
6	94.0		150.4	30.8	14,130		17,000		1.015	153.0	184.0	
7	49.0		146.7	30.8	7,200		8,700		1.022	150.0	181.4	
8	0		145.5	30.8					.996	175.6	175.6	
9	45.0		145.2	30.8	7,920		6,530		.980	163.6	135.0	
10	76.0		146.0	29.6	13,340		11,100		.832	146.0	121.5	
11	92.0		138.8	49.2	17,300		12,800		.703	132.0	97.5	
12	91.5		120.0	29.6	13,680		11,000		.560	83.7	67.2	
13	78.0		135.6	30.8	12,970		10,570		.403	67.0	34.7	
14	57.0		172.7	26.0	11,320		9,840		.260	57.6	45.0	
15	34.0		196.9	26.0	7,570		6,700		.130	29.0	25.6	
16	13.5		307.6	26.0	4,500		4,150		.040	13.4	12.3	
Total					102,100	88,130	84,940	108,960			19,28.4	19,61.3

Summary { Max. positive moment (102,100 - 88,130) (1000) = 13,970,000" # (Dead plus live)
 Thrust occurring for max. positive mom. condition = 1,928,400 #
 Max. negative moment (108,860 - 84,940) (1000) = 23,920,000" #
 Thrust occurring for max. negative mom. condition = 1,961,300 #
 For this section A = 194" #
 I = 385,000" #
 e = 58.5"

Temperature stresses
 Moment = 10350 x 529" = 5,480,000" # f_s = -1240 ± 5,480,000 x 58.5 = 796 #/in (Temp)
 Thrust = 10350 x .699 = 7,240 # Total D.L.+L.L.+Temp = 14536 #/in

For this section A = 194" #
 I = 385,000" #
 e = 58.5"
 Thrust = 10350 x .699 = 7,240 #
 Moment = 10350 x 529" = 5,480,000" #
 f_s = -1240 ± 5,480,000 x 58.5 = 796 #/in (Temp)
 Total D.L.+L.L.+Temp = 14536 #/in

TABLE 22.—MOMENTS AND THRUSTS AT PANEL POINT 2

St. No.	Ordinates		Dead load concentration (thousands lb.)	Live load concentrations (thousands lb.) + Mom. - Mom.	Maximum positive moment (thousands of in.-lb.)	Maximum negative moment (thousands of in.-lb.)	Thrust (thousands of lb.)	For + Mom.	For - Mom.
	+	-							
1	41.8	-	292.6	24.8	732.0	12200	0.30	9.5	8.8
2	85.0	-	188.8	44.1	31500	25500	.720	168.0	136.0
3	27.0	-	149.3	29.6	4830	4030	.805	144.0	120.0
4	33.4	33.4	120.8	30.8	4030	5060	.882	106.4	133.7
5	65.6	65.6	142.3	29.6	9430	11270	.953	135.4	163.5
6	80.8	80.8	150.4	49.2	12150	16100	1.008	151.5	201.0
7	75.6	75.6	146.7	30.8	11100	13400	1.030	151.0	183.0
8	57.5	57.5	145.5	30.8	8360	10120	1.020	148.5	180.0
9	35.6	35.6	145.2	30.8	5170	6270	.960	139.4	169.0
10	15.0	15.0	146.0	30.8	2190	2650	.663	126.0	151.5
11	2.0	2.0	138.8	30.8	340	280	.734	124.0	101.8
12	13.8	13.8	120.0	30.8	2080	1660	.580	87.5	69.6
13	17.0	17.0	135.6	30.8	2830	2310	.426	70.9	57.8
14	15.3	15.3	172.7	26.0	5040	2640	.278	55.2	48.0
15	10.7	10.7	196.9	26.0	2390	2110	.104	23.2	20.5
16	4.2	4.2	307.6	26.0	1400	1290	.047	15.7	14.4
					61670	52430		1656.2	1758.6

Summary { Max. Positive moment (61670 - 52430)(1000) = 9240,000 # (Dead plus live)
 Thrust occurring for max. positive mom. condition (" " ")
 Max. negative moment (64870 - 52020)(1000) = 12,850,000 # (" " ")
 Thrust occurring for max. negative mom. condition (" " ")

For this section A = 1850^{1/4} f_s = 1758600 + 12850000 x 53.5 = 11680 #/a² (Dead+live)
 I = 315000⁴
 e = 53.5"

Temperature stresses Moment = 10350 # x 310" = 3210000 # f_s = -8000 + 3210000 / 315000 = 500 #/a² (Temp)
 Thrust = 10350 # x .775 = 8000 # Total D.L. + L.L. + Temp = 12180 #/a²

TABLE 23.—MOMENTS AND THRUSTS AT PANEL POINT 3

Panel	Ordinates		Dead load concentrations (thousands lb.)	Live load concentrations (thousands lb.)	Maximum positive moment (thousands of in.-lb.)		Maximum negative moment (thousands of in.-lb.)		Thrust (thousands of lb.)		
	+	-			+	-	+	-	Ord.	For +Mom.	For -Mom.
1	29.0	-	292.6	26.0	8940	-	8480	.040	12.3	11.7	
2	96.0	186.8	186.8	24.8	20500	-	18100	.100	21.4	18.9	
3	190.0	149.3	149.3	49.2	37800	-	28400	.756	150.0	113.0	
4	96.2	120.8	120.8	29.6	14480	-	11600	.844	127.0	101.8	
5	18.0	142.3	142.3	30.8	3120	-	2560	.930	161.0	132.0	
6	37.7	150.4	150.4	30.8	5670	-	6830	.997	150.0	181.0	
7	70.0	146.7	146.7	30.8	10280	-	12400	1.033	157.2	183.4	
8	82.6	145.5	145.5	29.6	12020	-	14480	1.023	149.0	179.2	
9	83.0	145.2	145.2	49.2	12050	-	16100	.970	141.0	188.0	
10	75.0	146.0	146.0	29.6	10940	-	13200	.864	126.0	151.7	
11	61.0	153.8	153.8	30.8	6460	-	10340	.748	103.8	126.8	
12	43.2	120.0	120.0	30.8	5180	-	6570	.600	72.0	90.5	
13	28.0	135.6	135.6	30.8	3800	-	4650	.437	59.2	72.6	
14	15.8	172.7	172.7	26.0	2730	-	3130	.285	49.2	56.6	
15	7.0	196.9	196.9	26.0	1380	-	1560	.150	29.5	33.4	
16	2.0	307.6	307.6	26.0	610	-	670	.050	15.4	16.7	
Total					84840		73120	69140	89870	1578.3	1657.3

Summary { Max. positive moment (84840 + 73120) (1000) = 11,200,000# (Dead plus live)
 Thrust occurring for max. positive mom. condition = 1,518,300# (" " ")
 Max. negative moment (89870 - 69140) (1000) = 20,730,000# (" " ")
 Thrust occurring for max. negative mom. condition = 1,657,300# (" " ")

For this section
 $A = 199 \text{ ft}^2$
 $I = 246300 \text{ ft}^4$
 $e = 50"$

Temperature stresses
 $\text{Moment} = 10350 \# \times 129" = 13409000 \#$
 $\text{Thrust} = 10350 \# \times .827 = 8560 \#$
 $f_s = \frac{1657300 \pm 20730000 \times 50}{246300} = 12520 \#/\text{ft}^2$ (Dead+live)
 $f_s = \frac{-8560 \pm 13409000 \times 50}{199} = 447 \#/\text{ft}^2$ (Temp)
 Total D.L. + L.L. + Temp = -12967#/\text{ft}^2

TABLE 24.—MOMENTS AND THRUSTS AT PANEL POINT 4

Panel	Ordinates		Dead load concentrations (thousands lb.)	Live load concentrations (thousands lb.) + Mom. - Mom.	Minimum positive moment (thousands of in.-lb.)		Maximum negative moment (thousands of in.-lb.)		Thrust (thousands of lb.)		
	+	-			+	-	+	-	Ord.	For + Mom.	For - Mom.
1	16.0		292.6	26.0	5700		4670		.040	12.7	11.7
2	63.5		188.8	26.0	13620		11940		.010	23.6	20.7
3	137.0		149.3	29.6	24500		20400		.210	37.6	31.3
4	238.0		120.8	49.2	40500		28700		.805	137.0	97.0
5	121.0		142.3	29.6	20800		17200		.900	154.5	128.0
6	271.0		150.4	30.8	4890		4060		.980	177.5	147.5
7	40.0		146.7	30.8	5870		7100		1.025	150.5	182.0
8	81.0		145.5	30.8	11800		14280		1.027	149.5	181.0
9	102.0		145.2	29.6	14800		17800		.980	142.3	171.0
10	106.7		146.0	49.2	15570		20800		.890	130.0	178.8
11	98.0		138.8	29.6	13600		16500		.762	105.7	128.0
12	80.0		120.0	30.8	9600		12050		.670	73.2	92.0
13	59.0		135.6	30.8	8000		9800		.448	60.7	74.5
14	38.7		172.7	26.0	6690		7680		.290	50.1	67.8
15	20.0		196.9	26.0	3940		4460		.150	29.6	33.5
16	6.0		307.6	26.0	1840		2000		.050	15.3	16.7
Total					109410		86970			1449.8	1551.5

Summary } Max. positive moment (109410 - 91710)(1000) = 17,700,000" # (Dead plus live)
 Thrust occurring for max. positive mom. condition = 1,449,800 # (" ")
 Max. negative moment (112470 - 86970)(1000) = 25,500,000" # (" ")
 Thrust occurring for max. negative mom. condition = 1,551,500 # (" ")

for this section } A = 192" #
 I = 26,6700" #
 e = 47" } f_s = 155,1500 / 192 ± 25500000 # 47 / 266700 = 12600 # / " # (Dead +
 temperature stresses } Moment = 10350 # x 18" = 186000 # # f_s = -3050 / 192 ± 186000 # 47 / 266700 = 80 # / " # (Temp)
 Thrust = 10350 # x .875 = 9050 # Total D.L. + L.L. + Temp = 12680 # / " #

TABLE 25.—MOMENTS AND THRUSTS AT PANEL POINT 5

Panel	Ordinates		Dead load concentrations (thousands lb.)	Live load concentrations (thousands lb.) ± Mom.	Maximum positive moment (thousands of in.-lb.)		Maximum negative moment (thousands of in.-lb.)		Thrust (thousands of lb.)			
	+	-			+	-	+	-	Ord.	For + Mom. For- Mom.		
1	5.0		297.6	26.0	1590		1460		.045	14.3	13.1	
2	33.0		188.8	26.0	7060		6230		.123	26.3	23.2	
3	82.2		149.3	30.8	14800		12260		.228	41.0	34.0	
4	154.0		120.8	29.6	23200		18600		.348	52.4	42.0	
5	238.0		142.3	49.2	45600		33800		.860	164.7	122.0	
6	111.5		150.4	29.6	20000		16800		.950	171.0	143.0	
7	16.0		146.7	30.8	2840		2350		1.005	178.4	147.4	
8	54.5		145.5	30.8	7930		9600		1.010	147.0	178.0	
9	97.0		145.2	29.6	14100		16950		.975	141.5	170.5	
10	116.2		146.0	49.2	17000		22700		.894	130.4	174.3	
11	109.0		138.8	29.6	16120		19550		.770	107.0	129.5	
12	78.0		130.0	30.8	12000		15080		.620	74.4	93.5	
13	78.0		135.6	30.8	10580		13000		.450	61.0	75.0	
14	53.0		172.7	26.0	9150		10520		.290	50.0	57.6	
15	28.0		196.9	26.0	5500		6250		.150	29.5	33.4	
16	8.5		307.6	26.0	2670		2830		.050	15.4	16.7	
Total					115190		94990		91500	116480	1404.3	1453.2

Summary (Max. positive moment (115190 - 94990) (1000) = 20,200,000 # (Dead plus live)
 Thrust occurring for max. positive mom. condition = 1,404,300 # (" " "
 Max. negative moment (116480 - 91500) (1000) = 24,980,000 # (" " "
 Thrust occurring for max. negative mom. condition = 1,453,200 # (" " "

For this section $A = 186 \text{ in}^2$
 $I = 235500 \text{ in}^4$
 $e = 44 \text{ in}$

Temperature stresses
 Moment = $10350 \# \times 138 \text{ in} = 1400000 \# \text{ in}$
 Thrust = $10350 \# \times .912 = 9450 \#$

$f_s = \frac{1453200 \pm 24980000 \times 44}{186} = 12480 \text{ #/in}^2 \text{ (dead+live)}$
 $f_s = \frac{20200000 \# (1000)}{235500} = 85.8 \text{ #/in}^2$
 $f_s = \frac{1404300 \#}{186} \pm \frac{14000000 \times 44}{235500} = 300 \text{ #/in}^2 \text{ (Temp)}$
 Total D.L. + L.L. + Temp = 12180 #/in^2

TABLE 26.—MOMENTS AND THRUSTS AT PANEL POINT 6

Station	Ordinates		Dead load concentrations (thousands lb.)		Live load concentrations (thousands lb.)		Maximum positive moment (thousands of in.-lb.)		Maximum negative moment (thousands of in.-lb.)		Thrust (thousands of lb.)	
	+	-	+	-	+	-	+	-	+	-	Ord.	For + Mom.
1	4.6		292.6		26.0		1330		1460		.050	14.6
2	11.5		188.8		26.0		2470		2170		.137	29.4
3	37.6		149.3		30.8		6770		5610		.230	45.0
4	78.7		120.8		30.8		11930		9500		.377	57.1
5	138.4		142.3		29.6		23800		19700		.502	66.1
6	220.0		150.4		49.2		43900		33700		.900	119.4
7	92.0		146.7		29.6		16200		13500		.964	170.0
8	7.0		145.5		15.0		1020		1120		.990	144.0
9	67.7		145.2		30.8		9830		11900		.962	139.8
10	101.5		146.0		29.6		14800		17800		.880	128.5
11	113.0		138.8		49.2		15700		21200		.765	106.0
12	105.0		120.0		29.6		12600		15700		.620	74.3
13	86.0		135.6		30.8		11680		14300		.463	62.8
14	58.8		172.7		26.0		10150		11690		.295	57.0
15	31.8		196.9		26.0		6250		7090		.150	29.5
16	11.0		307.6		26.0		3380		3670		.050	15.3
Total			105070		86740		83580		105930			1332.8

Summary { Max. positive moment (105070 - 86740) (1000) = 20,330,000 #
 Thrust occurring for max. positive mom. condition = 1,332,800 #
 Max. negative moment (105930 - 83580) (1000) = 22,350,000 #
 Thrust occurring for max. negative mom. condition = 1,376,800 #

For this section A = 183.5 ft⁴
 I = 217300
 e = 42.8 in

f_s = 13,76800 ± 22,350,000 x 42.8 = 11920 #/in² (head + live)
 183 217300

Temperature stresses Moment = 10350 # x 229 in = 2,370,000 # f_s = -9900 ± 2,370,000 x 42.8 = 530 #/in² (Temp)
 Thrusts = 10350 # x .956 = 9900 # Total D.L. + L.L. + Temp. = 12450 #/in²

TABLE 27.—MOMENTS AND THRUSTS AT PANEL POINT 7

Panel	Ordinates		Dead load concentrations (thousands lb.)	Live load concentrations (thousands lb.)	Maximum positive moment (thousands of in.-lb.)		Maximum negative moment (thousands of in.-lb.)		Thrust† (Thousands of lb.)		
	+	-			+	-	+	-	Ord.	For+ Mom.	For- Mom.
1		8.4	292.6		26.0			2680	.050	14.6	15.9
2		6.0	188.8		26.0			1710	.146	27.6	31.2
3	0	0	149.3	30.8	30.8				.270	48.6	48.6
4	13.0		120.8	30.8		2880			.406	61.5	49.0
5	53.8		142.3	30.8		9320	2300		.540	93.5	76.8
6	110.0		150.4	29.6		19800	7650		.660	118.0	99.2
7	190.0		146.7	49.2		37200	16540		.910	178.0	138.6
8	71.5		145.5	29.6		13560	27900		.948	166.0	138.0
9		11.0	145.2		16.0		11300	1770	.934	155.4	150.0
10		62.4	146.0		30.8		9100	11100	.864	126.0	152.6
11		87.6	138.8		29.6		12150	14750	.754	104.4	127.0
12		90.0	120.0		49.2		10800	15200	.616	74.0	104.0
13		78.0	135.6		29.6		10600	12900	.450	61.0	74.3
14		56.3	172.7		26.0		9710	11200	.290	50.0	57.7
15		32.0	196.9		26.0		6300	7120	.155	30.5	34.5
16		11.0	307.6		26.0		3380	3660	.055	16.9	18.3
Total						82760	67600	65690		1306.0	1311.1

Summary { Max. positive moment (82760 - 67600)(1000) = 15,160,000 # (Dead plus live)
 Thrust occurring for max. positive mom. condition = 1,306,000 # (" " ")
 Max. negative moment (82090 - 65690)(1000) = 16,400,000 # (" " ")
 Thrust occurring for max. negative mom. condition = 1,311,100 # (" " ")

For this section A = 159 #² I = 164600 #⁴ e = 40.7"
 $f_s = \frac{1311000 \pm 16400000 \times 40.7}{159} = 12300 \text{ } / \text{ } e \text{ (dead+live)}$
 $f_s = \frac{2,980,000 \text{ } \times 288}{10350 \text{ } \times .984} = 10200 \text{ } \#$
 Temperature stresses Moment = 10350 # x 288" = 2,980,000 # f_s = -10200 ± $\frac{2980000 \times 40.7}{164600}$ = 800 #/e (Temp)
 Thrust = 10350 # x .984 = 10200 # Total D.L. + L.L. + Temp. = 13100 #/e

TABLE 28.—MOMENTS AND THRUSTS AT PANEL POINT 8

Panel	Ordinates		Live load concentrations (thousands lb.)		Maximum positive moment (thousands of in. lb.)		Maximum neg. moment (thousands of in. lb.)		Thrust (thousands of lb.)	
	+	-	+ Mom.	- Mom.	+	-	+	-	For + Mom.	For - Mom.
1	10.2	292.6	26.0		2980		3250		.052	15.2
2	21.5	188.8	26.0		4060		4670		.150	28.3
3	27.6	149.3	30.8		4120		4970		.283	42.2
4	25.6	120.8	30.8		3090		3880		.428	51.7
5	10.7	142.3	30.8		1520		1850		.570	31.0
6	23.0	150.4	30.8		4170		3460		.700	127.0
7	83.8	146.7	29.5		15100		12600		.792	139.5
8	181.6	145.5	49.2		35300		26400		.900	175.0
9	78.0	145.2	29.5		13620		11330		.892	155.8
10	3.5	146.0	16.0		570		510		.837	135.5
11	39.0	138.8		29.5		5410		6560	.731	101.5
12	56.0	120.0		49.2		6720		9460	.595	71.4
13	35.0	135.6		29.5		7450		9080	.445	60.3
14	44.0	172.7		26.0		7580		8700	.292	50.3
15	27.0	196.9		26.0		5370		6020	.155	30.5
16	11.0	307.6		26.0		3380		3670	.055	16.9
						+68760	-51620	+54300		1282.1
								-62050		1275.0

Summary { Max. positive moment (68760 - 51620)(1000) = 17,140,000" # (Dead plus live)
 Thrust occurring for max. positive mom. condition (" " ")
 Max. negative moment (62050 - 54300)(1000) = 7,750,000" # (" " ")
 Thrust occurring for max. negative mom. condition (" " ")
 For this section A = 158ⁱⁿ x 4^{ft} f_s = 1282,100 ± 17,140,000 x 40 = 12440 #/in² (D & L)
 I = 160100ⁱⁿ f_s = -10320 ± 3,260,000 x 40 = 74.5 #/in² (Temp)
 e = 40 Moment = 10350" x 315" = 3,260,000" # f_s = 13185 #/in²
 Thrust = .998 x 10350 = 10320" # Total stress DL+LL+Temp = 13185 #/in²

SECTION 10

ANALYSIS OF TWO-HINGED ARCHES

The method of analysis described in Section 9 applies to two-hinged arches. Consider the two-hinged rib arch span shown in Fig. 1 on folding page. To simplify the analysis, the rib has been considered as having a constant moment of inertia from end to end. It is apparent that a like method of analysis would suffice were the rib section of varying dimension.

From Fig. 1, it is seen that there will be one redundant reaction component which for convenience, we will assume as being the horizontal component at the left skewback.

Equation (102) of p. 444 may be written for this redundant as follows:

$$\Delta_x + \Delta_{tx} + \Delta_{t'x} - \Sigma r_x \Delta_r = \Sigma \frac{N_o n_x ds}{AE} + \Sigma \frac{M_o m_x ds}{EI} + X \left[\frac{\Sigma (n_x)^2 ds}{AE} + \frac{\Sigma (m_x)^2 ds}{EI} \right] + \Sigma n_x ct ds + \Sigma \frac{m_x}{h} (ct' ds)$$

It will be noted that the residual span is not a cantilever as in the case of the fixed arch span, but a simple beam.

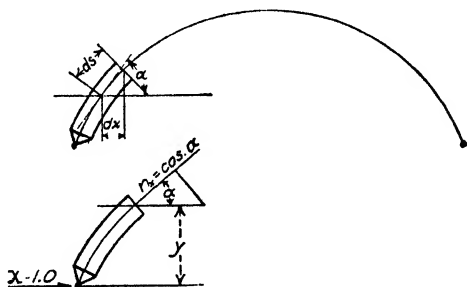

FIG. 2.

If we assume the hinges to be supported on rigid and unyielding shoes, which is nearly always the case in construction of this kind, the entire left-hand member of the above equation vanishes and we can greatly simplify the analysis.

From Fig. 2, it is at once observed that

$$\begin{aligned} n_x &= \cos \alpha \\ m_x &= y \\ ds \cos \alpha &= dx \end{aligned}$$

The expression in the brackets in the above general equation may then be written

$$\left[\sum \frac{dx \cos \alpha}{AE} + \sum \frac{y^2 ds}{EI} \right]$$

Designating the above term for the present by the letter D , we may write an expression for the redundant X (separating the effects of gravity loadings, temperature, etc.) as follows:

For gravity loading

$$X = \frac{\sum \frac{N_o dx}{AE} + \sum \frac{M_o y ds}{EI}}{D}$$

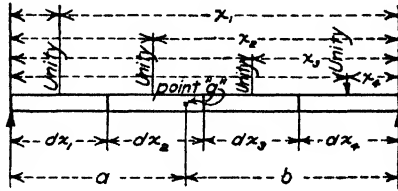

$$\begin{aligned} M_g & \text{ [Moment at point } g \text{ due to unit loads shown]} \\ & = [x_1 + x_2 + x_3 + x_4] \frac{a}{L} - (x_1 - b) - (x_2 - b) \\ \Sigma m_g & \text{ [the summation of moments at the above load} \\ & \text{ points due to a unit load at point } g] \\ & = \frac{a}{L} (x_1 + x_2) + \left[\frac{a}{L} \right] x_2 - (x_2 - b) + \left[\frac{a}{L} \right] x_3 - (x_3 - b) \\ & = \frac{a}{L} (x_1 + x_2 + x_3 + x_4) - (x_1 - b) - (x_2 - b) \\ \therefore M_g & = \Sigma m_g \end{aligned}$$

FIG. 3.

Except for very flat arches, we may neglect the term $\sum \frac{N_o dx}{AE}$ without material error. This will be done in this case. Also we may write for a unit load at any point g

$$M_o = m_o$$

Whence, for a unit load at any point g

$$X_o = \frac{\Sigma m_o y \frac{ds}{EI}}{D}$$

Before going further, it is necessary to demonstrate a simple relationship governing loads on any simple beam as follows:

Consider the simple beam shown in Fig. 3 and let the same be divided into any given number of linear increments dx .

Let M_o represent the moment at any point g due to a series of unit loads one at the center of each dx division.

Let Σm_o represent the summation of the moments at the center of each dx division caused by a unit load applied at point g .

From Fig. 3, it is easily seen that

$$\Sigma m_o = M_o$$

It should now be clear that $\Sigma m_g \cdot \frac{y ds}{EI}$ represents the moment at the given point g caused by the application of a system of loads $Gy = \frac{y ds}{EI}$ at the center of each ds division of the arch rib.

It is therefore apparent that if the loads $Gy = \frac{y ds}{EI}$ be laid off on a vertical load line with pole distance $D = \left[\Sigma \frac{dx \cos \alpha}{AE} + \Sigma \frac{y^2 ds}{EI} \right]$ the equilibrium polygon plotted therefrom will be the influence line for the redundant X .

Pursuant to the above, the arch rib is now divided into equal linear elements ds (in this case $ds = 120$ in. except for the spring line elements which are 156 in. in length). The elastic loads $G = \frac{ds}{EI}$ are next computed and also the terms $C_j = \frac{y ds}{EI}$. These loads are now laid off on a vertical load line, as shown in Fig. 1.

The pole distance D is next calculated, the work being tabulated below as follows:

CALCULATION OF ELASTIC LOADS AND POLE DISTANCE D
(E Assumed = 29)

Division number	y	$Gy = \frac{y ds}{EI}$	Gy^2	$dx \cos \alpha^1$
1	54	0.0041	0.22	0.72
2	144	0.0083	1.20	0.70
3	221	0.0127	2.81	0.76
4	286	0.0164	4.68	0.84
5	348	0.0200	6.96	0.92
6	398	0.0229	9.12	0.98
7	443	0.0254	11.20	1.04
8	476	0.0274	13.00	1.10
9	503	0.0288	14.50	1.14
10	522	0.0300	15.70	1.16
11	530	0.0305	16.20	1.18
Total.....	95.59	10.44
Σ	(For entire span)		191.18	20.88

¹ This term may also be determined graphically as shown in Fig. 1b, on folding page.

The area A for the arch rib in question (see Fig. 1) is 63 sq. in. The pole distance D is therefore

$$191.18 + \frac{20.88}{(29)(63)} = 192.75$$

With this pole distance (divided by 500 for convenience in plotting), the equilibrium polygon is constructed for the loads Gy . The ordinate

to this polygon intercepted by the vertical through any point g measures to the scale of the rib diagram the term

$$\frac{\sum m_o y ds}{EI} = 500X_o$$

The area included between this equilibrium polygon and its closing line is, therefore, the influence line for the redundant X with a factor of 500.

The influence line for the redundant X thus determined, it now remains to construct influence lines for the moments, thrusts, shears and fiber stresses at the various points along the rib.

As discussed in the section on three-hinged arch design, the fiber stress at the extreme intradosal, or extreme extradosal fiber is not a linear function of the moment at the neutral axis, on account of the effect of the direct axial thrust. This fiber stress is, however, a direct linear function of the moment about the "kernal" point corresponding to the fiber stress in question.

Proceeding therefore, as in the case of the three-hinged rib arch, we may lay off the point k_1 whose distance *below* the neutral axis is equal to the quantity $\frac{r^2}{e_e}$, and also the kernal point k_2 whose distance *above* the neutral axis is equal to the quantity $\frac{r^2}{e_i}$. In the above, the term r represents the radius of gyration $\left(\sqrt{\frac{I}{A}}\right)$ of the rib section, e_e the distance from the neutral axis to the extreme extradosal fiber, and e_i that to the extreme intradosal fiber.

As in the chapter on three-hinged arches, we may at once prove that

$$f_e = M_{k_1} \left(\frac{e_e}{I} \right)$$

and

$$f_i = M_{k_2} \left(\frac{e_i}{I} \right)$$

It is only necessary, therefore, to plot influence lines for moments about the two "kernal" points on any given section, as these are obviously identical in form with the influence lines for fiber stress at the section in question.

Consider first the section $b-b$ (Fig. 1*d*) and let k_1 and k_2 be the two "kernal" points.

Considering first the intradosal kernal point k_2 whose ordinate measured from the horizontal through X is equal to y_2 .

The total moment M_{k_2} at this point is given by the expression

$$M_{k_2} = M_0 - Xy_2 = y_2 \left(\frac{M_0}{y_2} - X \right)$$

In an exactly similar manner, the moment about the kernal point k_1 is given by the expression

$$M_{k_1} = M_0 - Xy_1 = y_1 \left(\frac{M_0}{y_1} - X \right)$$

Therefore, if the moment lines $\frac{M_0}{y_2}$ and $\frac{M_0}{y_1}$ are simply superimposed upon the X influence line, the area representing the difference between these two areas (the shaded area Fig. 1) is the influence line for the desired moment at the kernal point.

For example, in Fig. 1c, the X line is replotted from Fig. 1c and (to the same scale) the influence line $\frac{M_0}{y_2}$ is superimposed thereon.

$\frac{M_0}{y_2}$ is proportional to the moment on a simple beam of span L and is fully determined by plotting the distance $b'b'''$ equal to $\frac{(L - x_2)(x_2)}{(L)(y_2)}$ and drawing the lines $a'b'''$ and $b''d'$.

The shaded area, therefore, measures to the scale of the arch drawing the term

$$\frac{M_0}{y_2} - X = \frac{M_{k_2}}{y_2} = f_i \left(\frac{I}{e_i y_2} \right) = f_i \text{ [a constant]}$$

In an exactly similar manner $b''b''v$ is laid off equal to $\frac{(L - x_1)(x_1)}{(L)(y_1)}$ and the line $\frac{M_0}{y_1}$ plotted.

The area between this line and the X line measures the term

$$\left(\frac{M_0}{y_1} - X \right) = \frac{M_{k_1}}{y_1} = f_o \left(\frac{I}{e_o y_1} \right) = f_o \text{ [a constant]}$$

It is apparent that the X line, once it is plotted, may be used as a base upon which to superimpose the $\frac{M_0}{y}$ lines for any section of the rib, and thus determine influence lines for fiber stresses at every point desired.

In this case, the kernal points for every point on the rib will lie on two curves parallel to the neutral axis, since $\frac{r^2}{e}$ is constant for every section. Should the depth or the moment of inertia vary from point to point, the kernal points must be located for each section investigated.

The above influence lines completely cover the effect of both bending moment and axial thrust; it only remains to investigate the effect of shearing forces on the rib.

These stresses are generally of comparatively slight importance as the axial stresses are very nearly normal to the rib.

If desired, however, the shear influence line for any section (as for example section *b-b*) may be plotted as follows:

If we designate the total tangential force or shear on this section by the term J , and if J_0 represents the corresponding shear at this same section considering only the residual simple span, we may at once write

$$J = J_0 + X \sin \alpha = \left[\frac{J_0}{\sin \alpha} + X \right] \sin \alpha$$

where α is the angle made by the arch axis at section *b-b* with the horizontal.

Noting that J_0 is negative for loads to the left of section *b-b*, the shear line may be plotted at once, as shown in Fig. 1*f*.

It will be observed that for a load just to the right of section *b-b*, $J_0 = (\text{left reaction}) \cos \alpha = \left(\frac{L-x}{L} \right) \cos \alpha$ and $\frac{J_0}{\sin \alpha} = \left(\frac{L-x}{L} \right) \cot \alpha$. For a load just to the left of this section, the beam shear J_0 is equal to $-\left(\frac{x}{L} \cos \alpha \right)$, and the term $\frac{J_0}{\sin \alpha} = -\left(\frac{x}{L} \cot \alpha \right)$. The lines $a''a'''$ and $d'''d''v$ are therefore made, to scale, equal to the quantity $\cot \alpha$, as shown in the figure.

This completes the analysis of stresses at section *b-b*; any other section can obviously be investigated in like manner.

Temperature Effects.—The horizontal thrust X_t due to temperature effects only, may be written at once from the general equation as follows:

For uniform temperature changes

$$X_t = \frac{\Sigma n_x c t d s}{D} = \frac{c t \Sigma d x}{D} = \frac{c t L}{D}$$

Also for any section, as section *b-b*

$$\begin{aligned} M_t &= X_t y \\ J_t &= X_t \sin \alpha \end{aligned}$$

In this manner, all the stresses due to a uniform temperature change may be readily evaluated for any given section.

For a variable temperature change, wherein the upper and lower fibers of the rib section differ in temperature by t' degrees,

$$\begin{aligned} X_t' &= \Sigma \frac{y}{h} c t' d s \\ M_t' &= X_t' y \\ J_t' &= X_t' \sin \alpha \end{aligned}$$

These last stresses may therefore, be evaluated in much the same manner as for a uniform temperature change.

The effect of the axial compression "rib shortening" may be taken care of as an equivalent temperature drop exactly as explained for the fixed arch.

INDEX

A

Allegheny, Pa., Davis Avenue bridge, 287
American Bridge Co., 356
Analysis, of fixed arches, 393-482
 application of formulas, 420-426
 calculations of 350-ft. fixed steel arch rib, 455-482
 deflections and panel point displacements in frames, 396-400
 derivation of expressions for internal work in ribs and beams, 404
 development of general elastic equations, 407-414
 direction of redundant forces, 426-428
 displacements and deflections in beams and ribs, 406
 elastic influence lines, for fixed framed arches, 414-428
 for rib arches, 446-455
 equations for rib arches, development of, 440-445
 fixed framed arches, analysis of, 429-440
 horizontal and inclined loads, 426
 influence diagrams, graphical solution for, 449
 laws of internal work in structural frames, 393-396
 redundant forces in a fixed framed arch, 408
 residual frames, 409-411
 simplification of elastic equations, 414-420
 stresses due to rib shortening or axial thrust, 453
 symmetrical arch ribs, 454
 spans, analysis of, 439
 temperature changes in rib arches, 450
 theorems relating to internal work in ribs and frames, 393-407

Analysis, of fixed arches, unsymmetrical spans, analysis of, 429-439
 work expressions for solid-web beams and cantilevers, 400-406
 of three-hinged arch bridges, 375-392
 of two-hinged arches, 483-488
Anchor arm lateral system, 78
 columns on bascule piers, 65
Anchorages for cantilever bridges, 275
 for suspension bridges, 335
Arch bridges, 359-374c
 three-hinged, 375-392
Arch frames, elastic equations for, 407-414
Arched cantilever bridges, 285
Arches, fixed, analysis of, 393-482

B

Balance requirements of bascule bridges, 39-43
Balancing span of bascule bridge, 104
Bascule bridges, 1-157d
 designs and types, 1-29
 foundations for spans, 58-73
 operating machinery, 124-157
 selection of type, 29-38
 structural design complete, 73-123
 superstructure design and erection problems, 38-58
Bascule superstructure design and erection problems, 38-58
 balance requirements, 39-43
 counterweights, 51
 dead-load stresses, 46-47
 design specifications, 57
 erection features to be considered in design, 49
 floor design, 48
 live-load stresses, 43-46
 wind-load stresses, 47
Beams, solid web, work expressions for, 400-406

- Bearings for pinion shaft on bascule bridge, 152
 for vertical-lift bridges, 178
 Beaver, Pa., bridge, 262, 274, 275, 277, 280, 281, 284
 Braced-chain suspension bridges, 321
 Brakes, hand, on bascule bridge, 154
 Breslau, Oder river bridge, 326, 327
 Bridges, bascule, 1-157*d*
 cantilever, 256-288*a*
 cited (*see* name of city, country, or river)
 continuous, 199-255*g*
 1923-1942, 255
 steel arch, general, 359-374*c*
 suspension, 289-358*j*
 swing, 180-198
 three-hinged arch, 375-392
 vertical lift, 158-179*c*
 British Columbia, C.N.P. railway bridge, 171
 Brown bascule, 27
 Budapest, Elizabeth bridge, 325, 357
 Buffer blocks, 78
 Buffers, in bascule piers, 65
 for vertical-lift bridges, 174
 Bushings for vertical-lift bridges, 178
 Buzzard's Bay bridge, Cape Cod Canal, 179
- C
- Cable, for suspension bridges, 289-294
 Cable-lift bascules, 8-15
 curved track and rolling counterweight, 13
 sectional counterweights, 13
 spiral counterweight drums, 10
 Cable spinning, for suspension bridges, 352, 358*d*
 Cables for vertical-lift bridges, 174, 178
 California, Red Rock bridge, 274, 288
 Cantilever bridges, 256-288*a*
 anchorage, 275
 arched type, 285
 compared with continuous bridges, 256
 computation for moments and shears, 262-269
 conditions of statical determination, 257
 economical ratio of span lengths, 283
 economy, 281
 Cantilever bridges, erection adjustments 270
 esthetic considerations, 288
 examples, 261
 lateral systems, 279
 quantities in spans, 284
 reactions for indeterminate type, 269
 relative rigidity, 283
 San Francisco-Oakland Bay bridge.
 East Bay crossing, 288*a*
 span lengths, 284
 statically determinate type, 257
 stringer expansion bearings, 280
 Cantilever walks for vertical lift bridges, 174
 Catenary of suspension bridges, 293
 Center of gravity of bascule bridge, 106
 Center-bearing swing bridges, 180-196
 lock mechanism, 144
 shafting, for bascule bridge, 149
 Chesterfield bridge, Connecticut River, 374*a*
 Chicago Bascule Bridge Co., 73
 Chicago, Belmont Avenue bridge, 23
 Clybourn Avenue bridge, 21
 Pennsylvania Railroad bridge, 168
 South Halstead Street bridge, 158, 159, 163
 Van Buren Street bridge, 1
 Chicago type of trunnion bascule, 20-24, 30, 38, 58
 Cincinnati, C. N. O. Railway bridge, 202, 217
 Newport bridge, 272
 Clifton bridge, 357
 Cologne, Rhine River bridge, 326
 Columns on main girder of bascule highway bridge, 100
 Concrete, amounts needed to balance bascules, 56
 Continuous bridges, 199-255*g*
 advantages, 199
 Allegheny River bridge, 211-214
 C. and O. Railroad bridge, Cincinnati, 255*a*
 C. N. O. bridge at Cincinnati, 202, 217
 comparison of elastic curves for different assumptions, 234
 with cantilever bridges, 256
 conditions favorable for, 201
 dead-load stresses, 237
 design and erection, 199

Continuous bridges, economic comparisons with simple spans, 199
 economy of, 200
 elastic curve, 218
 for a continuous truss, 230
 for three-span bridge, 237
 for variable I, 226
 fixed points in continuous spans, 250
 Hancock bridge, 255*e*
 history of, 202
 influence diagram for bending moments, 220
 for continuous trusses, 236
 Lake Champlain bridge, 255*b*
 Licking Creek bridge, 255*e*
 for shears, 222
 for three-span type, 244
 live-load stresses, 236
 loading placement, rules for, 252
 Ludlow Ferry bridge, 255*d*
 method of double influence lines, 246
 moments and shears for two unequal spans, 225
 multiple-span continuous girders, 249
 Nelson River bridge, 214-217
 number of spans, 201
 prejudices against, 200
 proportions, economic, 201
 reactions for two continuous spans, 225
 Sagamore bridge, Cape Cod Canal, 255*c*
 Sagamore Creek bridge, New Hampshire, 255*e*
 settlement of supports, 253
 stresses, 218
 symmetrical three-span continuous girders, 241
 three-span, 237, 249
 triangular variation of I, 227
 two equal spans, 223
 unequal spans, 223
 (*See also* Sciotoville bridge)

Cost of bascule and swing bridges, 5-8
 Counterweight calculations for a bascule highway bridge, 104
 Counterweight pits, 64
 Counterweights for vertical lift bridges, 173
 in bascules, 51

Cowing bascule, 27

Crib vs. sheet piling, 69
 Cumberland river bridge, 356

Curved track and rolling counterweight type of bascule, 13

D

Dead-load stresses in counterweight arm, on bascule bridge, 86
 on bascule bridges, 46-47, 91
 Dead loads, calculation for bascule highway bridge, 83
 on bascule foundations, 59
 Deck span vs. through bascules, 33-37
 Deflection sheaves for vertical-lift bridges, 178
 Deflections, in beams and ribs, 406
 in structural frames, 396-400
 Design, recent developments affecting, 157-157*d*
 Designs and types of bascule bridges, 1-29
 adaptability to wide roadways, 3
 advantages, 1
 Brown bascule, 27
 cable-lift type, 8-15
 Chicago type, 20-24, 30, 38, 58
 collisions with river craft, 5
 comparison with vertical lift, 5
 Cowing type, 27
 duration of opening, 2
 early types, 1
 economy, compared with swing type, 5-8
 Page and Schnabel type, 27
 patented types, 28-29
 pier considerations, 2
 rapidity of operation, 1
 roller-lift type, 15
 safety to land traffic, 4
 semi-lift bascule spans, 25
 Strauss type, 24
 trunnion type, 19
 Waddell and Harrington type, 27
 Displacements, in beams and ribs, 406
 in structural frames, 396-400
 Double-leaf bascule vs. single, 30-33
 Drums for operating vertical-lift bridges, 178

E

Economy of bascule bridges vs. swing type, 5-8

- Elastic curve in continuous bridges, 218
 equations for arch frames or trusses, 407-414
- Elongation of cable in suspension bridges, 296
- England, Britannia bridge, 202
 Bryne bridge, 202
 Forksey bridge, 202
- Equalizers for vertical-lift bridges, 174
- Equations for arch frames or trusses, 407-414
- Erection adjustments of cantilever bridges, 270
 features in design of bascules, 49
 problems in bascule bridges, 38-58
- Ericson, J., 21
- F
- Fenders on bascule piers, 71
- Fixed arches, analysis of, 393-482
 framed arches, analysis of, 429-440
 elastic influence lines for, 414-428
- Floor design of bascule bridges, 48
- Floors, light, effect of, 157*b*
- Floor slab of bascule highway bridge, 99
- Floor system for a bascule highway bridge, 79
- Footbridges of suspension bridges, 349
 cables, stringing, 358*b*
 erection of, 358*b*
- Foot Bros. Gear & Machinery Company, 148
- Foundations for bascule spans, 58-73
 action of loads, 59
 anchor columns, 65
 buffers, 65
 conditions peculiar to, 58
 counterweight pits, 64
 fenders, 71
 operator's houses, 69
 pier, description of, 63
 sheet pile vs. crib, 69
 tremie seal, 66
 watertight counterweight pits, 61
- France, Fades viaduct, 202
 Passy bridge, 287
 Pont de Trans, 288
- Friction on trunnions of bascule bridge, 125
- G
- Gage on vertical-lift bridges, 175
- Gates for vertical-lift bridges, 174
- Gear design for bascule bridge, 129, 135
 for center lock drive, 150
- Gears for vertical-lift bridges, 178
- Grillage braces on a bascule highway bridge, 103
- Guides for vertical-lift bridges, 173
- H
- Hand brakes, on bascule bridge, 154
 operating mechanism for bascule bridge, 143
- Heel trunnion type of bascule, 25
- Highway bridge, structural design of, 73-123
- Horizontal girder for bascule highway bridge, 81
- I
- Impact stresses on a bascule bridge, 92
- India, Jubilee bridge at Calcutta, 285, 288
- Interstate toll bridge, Portsmouth, N.H., 179*b*
- K
- Kansas City, Mo., Fratt bridge, 167
- Kettle Rapids, Canada, Hudson Bay R.R. bridge, 202, 216
- Kingston, N.Y., bridge, 352, 354, 358
- L
- Lake Champlain bridge, 255*b*
- Lateral system, for a bascule bridge, 93
 of cantilever bridges, 279
- Lewis, W., formula for gear teeth, 130
- Licking Creek bridge, Maryland, 255*e*
- Live-load stress diagrams, for bascule bridge, 88
 loads, on bascule foundations, 59
 stresses on bascule bridges, 43-46
- Lindenthal, G., 211
- Loads of bascule highway bridge, 75
- Locking apparatus for vertical-lift bridges, 174
- Ludlow Ferry bridge, 255*d*

M

- Machine design for bascule bridges, 124-157
- Machinery equipment for vertical-lift bridges, 177
 - house for vertical-lift bridges, 175
 - layout for bascule bridge, 133
- Maxwell's theorem, 196
- Memphis bridge, 285
- Mexico, Arroya del Chico railroad bridge, 285, 287
- Mississippi river, Thebes bridge, 279, 285
- Moments, computation for, in cantilever bridges, 262-269
 - in swing bridges, 191
- Montreal, Laclue bridge, 202
- Motor power for center lock, on bascule bridge, 145
- Murray, S., comment on economy of bascule and swing bridges, 7
 - originator of type of bascule, 10

N

- Negative shear, in swing bridges, 187
- Nelson river continuous bridge, 214-217
- New Brunswick, Can., St. John and Quebec railway bridge, 172
- New York City, Brooklyn bridge, 328, 333, 350, 352
 - Manhattan bridge, 327, 328, 333, 348, 349, 352, 353, 355, 357
 - Queensboro bridge, 261
 - Riverside Drive viaduct, 287
 - Williamburgh bridge, 327, 328, 333, 347, 352, 353

O

- Operating machinery of bascule bridges, 124-157
 - bearings for main pinion shaft, 152
 - center lock mechanism, 144
 - shafting, 149
 - data for problem, 124
 - friction on trunnions, 125
 - frictional resistance, 127
 - gear design, 129, 135
 - gearing for center lock drive, 150
 - hand brakes, 154
 - operating mechanism, 143

- Operating machinery, inertia of moving mass, 126
 - keys for shaft, 143
 - machinery layout, 133
 - main trunnions, 152
 - motor power for center lock, 145
 - pin in crank, 149
 - rack and main drive pinion, 128
 - shafting, design of, 140
 - starting force at rack circle, 126
 - tangential force at rock circle, 128
 - wind pressure, 125
 - resistance, 127
- Operating machinery on vertical-lift bridges, 175
- Operation of swing span and bascule bridges, 1
- Operator's houses, 69, 175
- Oregon City, Ore., Willamette River bridge, 364, 368, 455
- Orford bridge, Connecticut River, 374a
- Ottawa, Inter-provincial bridge, 279
- Overhead counterweight type of bascule, 24

P

- Page bascule bridge piers, 37
- Peterson, I. C., comment on Chicago bascule, 21
- Pier considerations for swing span and bascule bridges, 2
 - fenders, 71
- Piers for bascule bridges, 37, 63
- Pihlfeldt, T. G., 21
- Pin in crank of bascule bridge, 149
- Pinions for vertical-lift bridges, 178
- Pits, counterweight, for bascule bridges, 64
- Pittsburgh, Allegheny River bridge, 202, 211, 214
 - Highland Park bridge, 270
 - Monongahela bridge, 274, 275, 284
 - Point bridge, 325
 - Sewickley bridge, 274, 277, 285
- Portland, Ore., Hawthorne Avenue bridge, 163
 - O. W. R. and N. Co.'s bridge, 167
- Positive moment, in swing bridges, 186
- Positive shear, in swing bridges, 184
- Power for vertical-lift bridges, 175, 177

R

- Rack of bascule bridge, 128
 - plates on a bascule bridge, 98
- Railway traffic, adaptability of bascule bridges to, 3
- Rainbow bridge, Niagara Falls, 374a
- Rail rolling lift, 30
 - type of bascule, 17, 37, 38, 53, 59
 - of vertical-lift span, 26, 53
- Rapp, F. A., comment on cost of bascule and swing bridges, 7
 - on duration of opening of draw bridges, 2
- Reaction displacements in structural frames, 399
- Redundant forces in a fixed framed arch, 408
- Residual frames, 409
- Rhine River bridge, Mainz, 374
- Rib arches, elastic influence lines for, 446-455
 - equations for, 440-445
- Rim-bearing swing bridges, 196-198
- Robinson, H. D., 355
- Roller-lift bascules, 15-19
 - Rall type, 17
 - Scherzer type, 15
- Rope-strand cables, 347
- Roumania, Danube River bridge at Cernavoda, 285
- Russia, Don River bridge, Rostoff, 172

S

- Salamanca, N. Y., cantilever bridge, 281
- Sagamore bridge, Cape Cod Canal, 255c
- Sagamore Creek bridge, 255e
- San Francisco-Oakland Bay bridge, East Bay crossing, 288a
- Scherzer rolling bascule bridge, 1, 30, 37, 38, 59
 - Rolling Lift Bridge Company, 15
- Sciotoville bridge, 200, 201, 202-211, 232, 234, 236, 237, 252-255
- Scotland, Forth bridge, 259, 260, 288
- Seattle, Eastlake Avenue bridge, 61
- Sectional counterweight type of bascule, 13
- Selection of type of bascule bridges, 29-38
 - arrangement of piers, 37
 - Selection of type of bascule bridges, relative merits, 38
 - single vs. double leaf, 29-33
 - through vs. deck spans, 33-37
- Sellwood, Ore., bridge, 374
- Semi-lift bascule spans, 25
- Shafting for bascule bridges, 140
- Shear in panels, of swing bridges, 188
 - lock stresses on a bascule bridge, 89
- Shears, computation for, in cantilever bridges, 262-269
- Sheaves for vertical-lift bridges, 174
- Sheet pile vs. crib, 69
- Single-leaf bascule vs. double, 29-33
- Specifications for design of bascules, 57
- Spiral counterweight drums, 10
- Steel arch bridges, 359-374c
 - braced-rib arches, 360
 - classification and types, 359
 - erection, 364
 - fixed or hingeless type, 362
 - loadings, 363
 - location of crown hinge, 372
 - merits of types, 362
 - shape of arch, 368
 - single-hinge type, 362
 - solid-rib arches, 360
 - spandrel-braced arches, 361
 - temperature stresses, 371
 - three-hinged type, 362
 - tied arches, 373
 - two-hinged type, 362
- Steel, volume of, in bascule bridge, 106
- Steinman, D. B., on Continuous bridges, 199-255
 - on Suspension bridges, 289-358
- Strauss Bascule Bridge Company, 20, 23, 24, 27
 - type of bascule, 24-25, 30, 37, 38, 53, 58
 - vertical lift, 30
- Stresses, on bascule highway bridge, 76
 - in continuous bridges, 218
 - in a swing span, 182
- Stringer expansion bearings, 280
- Stringers and floor beams for bascule highway bridge, 79, 99
- Strobel Steel Construction Company, 15, 17, 26
- Structural design of bascule highway bridge, 73-123
 - anchor arm lateral system, 78

- Structural design of bascule highway
 bridge, balancing span, 104
 brackets, 98
 buffer blocks, 78
 calculation of dead loads, 83
 center of gravity of entire leaf, 106
 columns on main girder, 100
 counterweight calculations, 104
 counterweights, 78
 dead-load stresses, 91
 in counterweight arm, 86
 description of problem, 73
 dimensions, 75
 floor slab, 99
 system, 79
 grillage braces, 103
 impact, 75
 impact stresses, 92
 lateral system, 93
 live-load stress diagrams, 88
 loads, 75
 main trunnion girder, 101
 truss members, 81
 rack plates, 98
 shear at center, 76
 lock stresses, 89
 shoe, 98
 stresses, permissible, 76
 stringers, 99
 volume occupied by structural steel,
 106
 wind-load stresses, 92
- Structural frames, displacements in, 396-
 400
 laws of internal work in, 393-396
- Superstructure design of bascule bridges,
 38-58
- Suspension bridges, 289-358j
 1923-1943, 358
 anchorages, design of, 333
 bending moments in side spans, 338
 braced chain type, 321
 cable, 289-294
 diameter, calculation of, 346
 spinning of, 358d
 wire, calculation of, 346
 wrapping, 355
 calculations, of stresses in tower, 345
 for two-hinged type, 335
 catenary, 293
 chain construction, 327
 construction features, 324
- Suspension bridges, deflections due to
 elongation of cable, 296
 deformations, in unstiffened cable, 295
 of cable, 294
 under unsymmetrical loading, 296
 design of, 324-335
 dimensions, 335
 economic proportions, 326
 erection of, 347-358
 eyebar-chain type, erection of, 357
 floor system, erection of, 353, 358j
 footbridges, erection of, 349, 358b
 forces acting on tower, 344
 hingeless stiffening trusses, 315
 influence lines for stresses, 301
 initial erection adjustments, 358d
 moments in stiffening truss, for two-
 hinged type, 336
 movement of top of tower, 343
 parallel-wire cables, 328
 rope-strand cables, estimate of, 347
 saddles, 332
 shears in side spans, 340
 in stiffening truss, 338
 spinning of cables, 352
 stiffened, 297-302
 straight backstays, 314
 stresses, 289
 in cable, for two-hinged type, 335
 in cables and towers, 295
 permissible unit, in concrete, 157a
 in reinforcing steel, 157a
 in structural steel, 157a
 in tower, calculation of, 345
 stringing the footbridge cables, 349,
 358b
 temperature stresses, 341
 in two-hinged trusses, 313
 three-hinged stiffening trusses, 302-306
 time required for erection, 357
 towers, design of, 332, 343
 erection of, 347, 358
 trusses, erection of, 353, 358j
 twisted-wire ropes, 330
 two-hinged stiffening trusses, 306-315
 types of, 324
 unstiffened, 294
 wind stresses in bottom chords, 342
 in tower, 345
 wire-rope cables, erection of, 356
 world's largest, features of, 358j
 wrapping wire, calculation of, 347

- Swing bridges, 180-198
 center bearing, 180-196
 combinations, 194
 compared with bascule, 1
 conditions of loading, 180
 dead load, bridge open, 194
 ends raised, 194
 general considerations, 180
 moments, 191, 194
 negative shear, 187, 193
 positive moment, 186
 shear in panel, 184
 reactions from Williot diagram, 194
 rim-bearing, 196-198
 general considerations, 196
 partial continuity, 197
 shear in panels, 188
 stresses in a swing span, 182
 with broken loads, 192
 with continuous loads, 193
- Symmetrical arch ribs, 454
 spans, analysis of, 439
- T
- Tacoma, Wash., City Waterway bridge, 168
- Temperature changes in beams and ribs, 406
 displacements in structural frames, 399
 in rib arches, 450
 work due to, 403
- Three-hinged arch bridges, 375-392
 algebraic calculation of reactions, 378
 equilibrium polygons, 375
 fiber stresses in solid ribbed arch spans, 385
 graphical analysis of stresses, 388
 influence lines for, 381
 stresses due to moving loads, 378
 wind stresses in spandrel-braced arch spans, 388
- Three-span continuous bridges, 237
- Through vs. deck span bascules, 33-37
- Towers of suspension bridges, 332
 of vertical-lift bridges, 172
- Traffic, safety to, over bascule bridges, 4
- Tremie seal, 66
- Triborough bridge, New York City, 179b
- Trunnion girder on bascule highway bridge, 101
- Trunnion-type bascules, 19
 heel-trunnion type, 25
 overhead-counterweight type, 24
 simple or Chicago type, 20-24
 Strauss type, 24-25
- Trunnions of bascule bridge, 152
- Truss members for a bascule highway bridge, 82
- Two-hinged arches, analysis of, 483-48
- U
- Unsymmetrical spans, analysis of, 42
 439
- V
- Vertical-lift bridges, 158-179c
 adaptability of types, 161
 advantages, 158
 bearings and bushings, 178
 buffers, 174
 cantilever walks and roadways, 174
 classification, 160
 compared with bascule, 5
 counterweight cables and balancing chains, 174
 counterweights, 173
 deflection sheaves, 178
 descriptions, 163
 equalizers, 174
 gage, 175
 gates, 174
 gears, 178
 general design, 172
 guides and centering blocks, 173
 locking apparatus, 174
 machinery equipment, 177
 house, 175
 operating cables, 178
 drums, 178
 machinery, 175
 operator's house, 175
 pinions, 178
 power equipment, 177
 required, 175
 sheaves, 174
 towers, 172
 truss of the lift span, 172
- Vertical-lift spans, recent, 179
- Volume of structural steel in bascule bridge, 106
- Von Babo, A., 23

W

- Waddell and Harrington bascule, 27
Waddell Company, 163
Waddell, J. A. L., 27, 158
Watertight counterweight pits, 61, 64
Williot diagram, 194
Willman, E., 21
Wind-load stresses on bascule bridges,
47, 60, 92
- Work expressions for solid-web beams and
cantilevers, 400-406
Worthington, C., 362
Wrapping wire, for suspension bridges,
347

Y

Young, H. E., 21

