

# Birla Central Library

PILANI (Jaipur State)

Engg. College Branch

R

Class No. 690.2

Book No. S331D v.3

Accession No. 32551



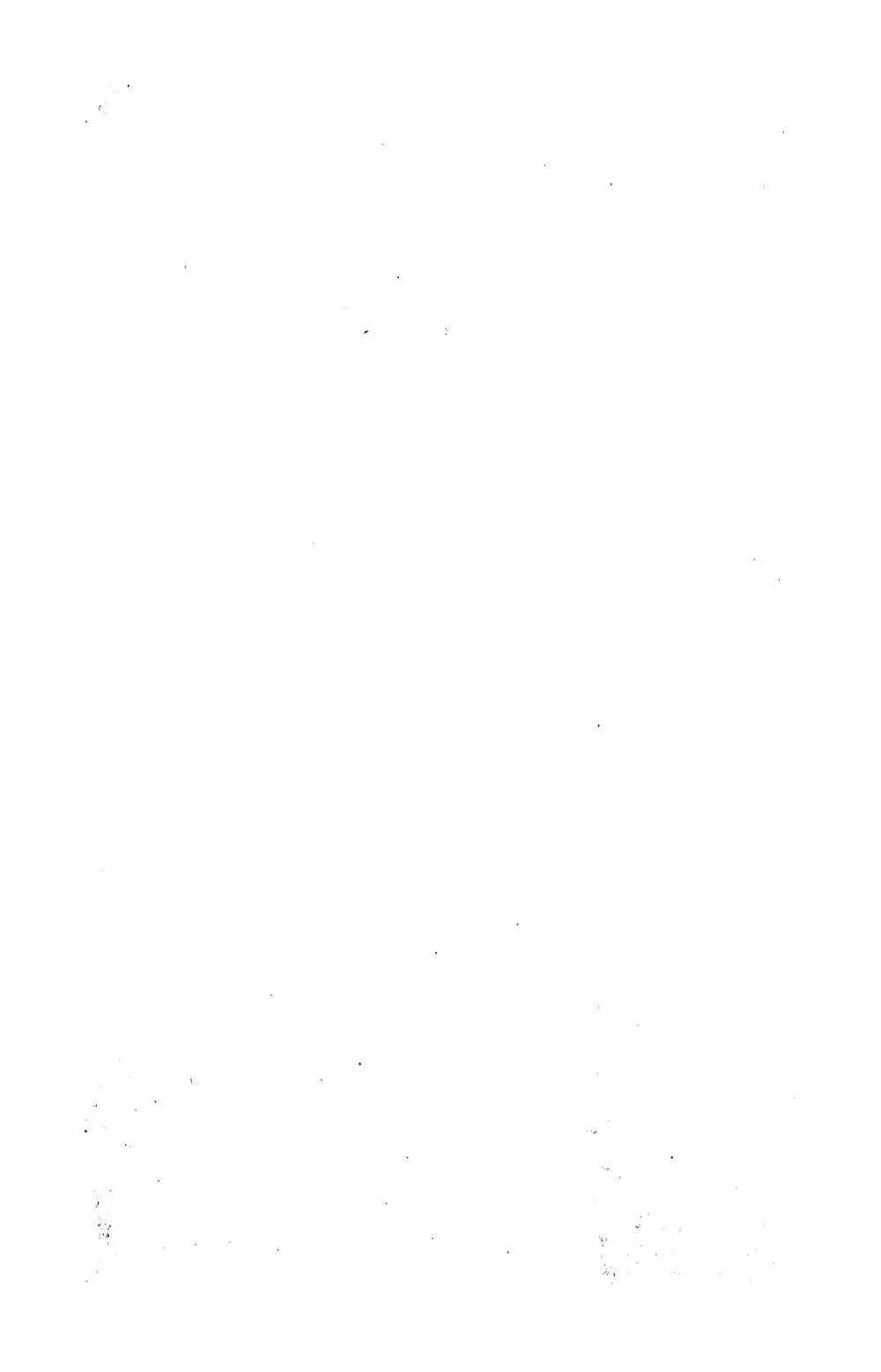

# FIELD PRACTICE

DATA BOOK for  
CIVIL ENGINEERS

By ELWYN E. SEELYE

VOLUME ONE — DESIGN. 417 pages.  
Illustrated.  $9\frac{3}{8} \times 11\frac{3}{4}$ . Cloth.

VOLUME TWO — SPECIFICATIONS AND  
COSTS. 325 pages. Illustrated.  $9\frac{1}{4} \times 11\frac{1}{2}$ . Cloth.

VOLUME THREE — FIELD PRACTICE.  
306 pages. Illustrated.  $4\frac{7}{8} \times 8$ . Cloth.

DATA BOOK FOR CIVIL ENGINEERS

---

# FIELD PRACTICE

ELWYN E. SEELYE

---

---

New York • JOHN WILEY & SONS, Inc.  
London • CHAPMAN & HALL, Limited

COPYRIGHT, 1947  
BY  
ELWYN E. SEELYE

---

*All Rights Reserved*

*This book or any part thereof must not  
be reproduced in any form without  
the written permission of the publisher.*

PRINTED IN THE UNITED STATES OF AMERICA

## PREFACE

Field practice embraces the inspection and sometimes supervision of construction of engineering works by a field man who may have the background of an inspector, a designer, a clerk-of-the-works, a contractor's superintendent, or a surveyor. If the inspection and supervision are performed in accordance with modern practice, the field man merits the dignity that is implied by the title of engineer.

Modern practice for field engineers comprises extensive technological advances, many of them made within the past decade. The purpose of this volume is to enable the inspector or field engineer to brief himself as to the essentials in the inspection and supervision of the work which he is to undertake. Its purpose is also to enable him to bring to the field the basic data which he will require.

For example, sampling of material for laboratory tests should be done in accordance with certain rules. The method of taking a concrete sample for a compression or flexure test is rigidly prescribed. Any deviation from the rules will detract from the validity of the test. Hence "Rules for Sampling" are included in this book.

Certain field tests, such as the concrete slump test, the penetration of asphalt test, and soil tests, are required to control the quality of construction. These tests should be performed according to certain rules; hence, "Instructions for Field Tests."

Field engineering includes the checking of material so that size, quality, and other properties are in accordance with plans and specifications. Therefore, tables such as the detailed dimensions of steel beams and of culvert pipe are included herein to enable an inspector to identify the exact size of a steel beam or the classification of a reinforced-concrete pipe.

A whole series of special tests have been developed in connection with the science of soil mechanics. A field engineer may be required to make these tests and to furnish information concerning them. In order that he may do so, detailed information is given to determine density, grain size, Atterberg limits, optimum moisture, field shear tests, C.B.R. values, and related data.

What items should be checked by an inspector? A check list for inspectors is included for such work as concrete, bituminous paving, steel, welding, and timber. Complete information for inspecting pile driving is also given. In addition, report forms are presented so arranged that the report becomes not only a progress report but also an inspector's



checking list. This is illustrated by the steel inspector's reports, of which Part I is a list of items to be checked off by the inspector and Part II is a progress report.

The importance of surveying to field engineering has been recognized, and a section of this volume provides the data a construction surveyor requires. Under "Surveying" are stadia reduction tables, stakeout problems, curve data, railroad turnout data, earthwork tables, transit and level problems, azimuth determination, isogonic chart, instrument adjustments, tape data, plotting problems, mapping symbols, and tables of measure, trigonometric formulas, and trigonometric functions.

The identification of common building stone and timber is assisted by photographs of different types or species placed in juxtaposition to emphasize points of difference.

A few words on job power together with cuts of construction machinery are given to assist the field engineer in talking to the contractor in his own language.

ELWYN E. SEELYE

## ACKNOWLEDGMENTS

In addition to the sources listed in the text, the author wishes to thank the following for their aid.

Dr. Arthur S. Tuttle, for his help and advice and for making available to the author his wide contacts for the collection of information.

Dean S. C. Hollister, of the College of Engineering, Cornell University, who has given the author advice and encouragement, particularly in regard to the general scope of the book.

Mr. Frank H. Alcott, of National Lumber Manufacturers Association.

Mr. L. E. Andrews, Regional Highway Engineer, Portland Cement Association.

Mr. Clinton L. Bogert.

Gilbert D. Fish.

Mr. E. M. Fleming, District Manager, Portland Cement Association.

Mr. Elliott Haller, of Haller Engineering Associates, Inc.

Mr. Prevost Hubbard and Mr. Bernard E. Gray, of The Asphalt Institute.

Mr. John Hoffine.

Mr. Elson T. Killam.

Mr. Ralph H. Mann, of American Wood-Preservers Association.

Mr. Edward A. Robinson, of Haller Engineering Associates, Inc.

Mr. John M. Stratton.

Mr. Russell Wise, C.E.

The author wishes to make special mention of the assistance received from the following members of his organization.

Mr. J. U. Wiesendanger for his work on general editing.

Colonel Burnside R. Value and Mr. A. L. Stevenson for general advice and counsel.

Messrs. E. G. Whitten, W. D. Bailey, V. J. Pacello, C. M. Throop, Patrick H. Murphy, A. H. Jorgensen, Laurence Vought, and S. D. Teetor.

Miss Jean M. Luckett for her assistance in editing.



# CONTENTS

## PART I

### INSPECTION

	PAGE
Typical Heavy Construction Equipment . . . . .	3
<b>Concrete</b>	
Field Sampling . . . . .	10
Field Testing . . . . .	12
Check List for Inspectors, Concrete—General . . . . .	13
Check List for Inspectors, Concrete—Paving . . . . .	19
Rules for Concrete Floors . . . . .	21
Approximate Data on Concrete Mixes . . . . .	23
Concrete Batching . . . . .	24
Quantities for Concrete Mixes . . . . .	25
Concrete Batching Computations . . . . .	34
Concrete Reinforcement . . . . .	39
Load Tests . . . . .	42
Report on Concrete Structures—Field Inspection (Short Form) . . . . .	43
Report on Concrete Structures—Field Inspection (Long Form) . . . . .	44
Report on Concrete Test Specimens . . . . .	45
Report on Concrete Test Beams . . . . .	46
Report on Cement Analyses . . . . .	47
Cement Shipping Report . . . . .	48
<b>Masonry</b>	
Check List for Inspectors . . . . .	49
Lime for Mortar and Masonry . . . . .	49
Identification of Building Stone . . . . .	50
<b>Structural Steel</b>	
Check List for Inspectors . . . . .	53
Structural Steel Sections . . . . .	55
Wire and Sheet Metal Gages . . . . .	58
Report on Structural Steel—Riveted or Bolted, Field Inspection . . . . .	60
Report on Structural Steel—Riveted or Bolted, Shop Inspection, Part I . . . . .	61
Report on Structural Steel—Shop Inspection, Part II (For both riveted and welded steel) . . . . .	62
Steel Mill Report . . . . .	63
<b>Welding</b>	
Common Welding Processes . . . . .	64
Welders' Qualification Test . . . . .	65
Welding Positions . . . . .	66

	PAGE
Weld Characteristics . . . . .	66
Illustrations of Acceptable and Defective Welds . . . . .	67
Fillet Weld Gages . . . . .	67
Weld Penetration and Arc Crater . . . . .	68
Electrodes and Their Uses . . . . .	68
Check List for Inspectors . . . . .	70
Identification of Iron and Steel . . . . .	71
Report on Structural Steel—Welded, Field Inspection . . . . .	72
Report on Structural Steel—Welded, Shop Inspection, Part I . . . . .	74
<b>Bridges</b>	
Field Data Required for Rating Existing Bridges . . . . .	75
Inspection of Existing Bridges . . . . .	75
Field Data for New Small Bridges . . . . .	78
Existing Bridge Inspection Report . . . . .	78
Field Data for New Structure . . . . .	80
<b>Painting</b>	
Check List for Inspectors . . . . .	81
<b>Foundations on Soil</b>	
Method of Conducting a Load Test . . . . .	82
Presumptive Bearing Capacity of Soils . . . . .	82
Check List for Inspectors . . . . .	84
<b>Pile Driving</b>	
Check List for Inspectors and Data . . . . .	84
Bearing Power of Piles . . . . .	86
Values of $E$ for McKiernan-Terry Pile Hammers . . . . .	86
Load Tests . . . . .	87
Report on Pile Driving . . . . .	88
<b>Timber</b>	
Wood Joists—Net Section . . . . .	89
Identification of Timber . . . . .	90
Check List for Inspectors . . . . .	94
Report on Wood Preservation . . . . .	96
<b>Ropes and Cable—Strengths</b> . . . . .	97
<b>Varieties of Knots</b> . . . . .	98
<b>Soils</b>	
Surveying and Sampling Methods . . . . .	99
Spacing and Depth of Borings and Test Pits or Test Holes . . . . .	100
Size of Samples . . . . .	100
Testing Equipment . . . . .	101
Typical Soil Profile Map . . . . .	105
Plan and Log of Test Pits for Airfield . . . . .	106
Boring Log . . . . .	107
Identification of Principal Types . . . . .	108
Identification by Mechanical Grain Size Analyses . . . . .	109
Classification of Soils by Horizons . . . . .	109
P.R.A. Classification . . . . .	110
Classification of Soil Mixtures . . . . .	112
Classification of Soils by Origin . . . . .	112

## CONTENTS

xi

	PAGE
Atterberg Limit Tests . . . . .	113
Moisture Determination . . . . .	115
Maximum Density, Optimum Moisture, Proctor Needle Plasticity Test . . . . .	117
California Bearing Ratio . . . . .	120
Field Density (Unit Weight) Test . . . . .	120
Bearing Values vs. Percentage of Compaction . . . . .	123
Mechanical Analysis (Grain Size) . . . . .	124
Effective Size and Uniformity Coefficient . . . . .	125
Optimum Moisture—Maximum Density Report . . . . .	126
Report on Density Determination . . . . .	127
Report on Soil Studies . . . . .	128
Report on Soils Classification . . . . .	129
California Bearing Ratio Report . . . . .	130
Boring Log . . . . .	131
Grain Size Classification Report . . . . .	133
 <b>Aggregates</b>	
Field Testing . . . . .	134
Sieve Analysis . . . . .	134
Approximate Absorption of Water by Aggregates . . . . .	136
Sieve Analysis Report . . . . .	137
 <b>Grading</b>	
Check List for Inspectors . . . . .	138
 <b>Bituminous Paving</b>	
Field Sampling . . . . .	139
Field or Plant Tests . . . . .	140
Check List for Inspectors, Bituminous Paving—General . . . . .	141
Check List for Inspectors, Plant-Mix Bituminous Paving . . . . .	146
Use of Bituminous Materials . . . . .	150
Quantities Required . . . . .	152
Quantities Per Unit . . . . .	155
Application Rate . . . . .	157
Standard Abridged Volume Correction Table . . . . .	158
Amounts of Material Per Square Yard . . . . .	159
Daily Bituminous Report for Macadam, Bituminous Treatments, Mix-in-Place . . . . .	160
Plant-Mix Bituminous Inspection—Daily Paving Report . . . . .	161
Plant-Mix Bituminous Inspection—Daily Plant Report . . . . .	162
Bituminous Paving Analyses Report . . . . .	163
Asphalt Report . . . . .	164
 <b>Sanitary Construction</b>	
Check List for Inspectors . . . . .	165
 <b>Pipe Laying</b>	
Cement-Asbestos Sewer Pipe (Transite) . . . . .	166
Clay Pipe, Standard Strength . . . . .	167
Clay Pipe, Extra Strength . . . . .	168
Corrugated Metal Culvert Pipe . . . . .	169
Non-Reinforced-Concrete Sewer Pipe . . . . .	170
Reinforced-Concrete Sewer Pipe . . . . .	171

	PAGE
Standard Strength Reinforced-Concrete Culvert Pipe . . . . .	172
Extra-Strength Reinforced-Concrete Culvert Pipe . . . . .	173
Concrete Pipe, Weights and Laying Lengths . . . . .	174
American Water Works Association Standard Cast-Iron Pipe . . . . .	175
Federal Specifications, WW-P-421 Standard . . . . .	175
Standard Thicknesses and Weights of Cast-Iron Pit Cast Pipe . . . . .	176
Approximate Quantities of Materials Used per Joint for Water Service . . . . .	177
Steel Pipe, A.S.T.M. A53-44, Weights and Dimensions . . . . .	178
Cement-Asbestos Water Pipe (Transite) . . . . .	179
Check List for Inspectors . . . . .	179
Report on Pipe Laying . . . . .	181
<b>Miscellaneous</b>	
Inspector's Time Record . . . . .	182
Payroll and Expense Record . . . . .	183
Report on Airfield Runways . . . . .	184
Inspector's Daily Report—General Construction . . . . .	186
General Contractor's Daily Report . . . . .	188
Job Power . . . . .	189
<b>PART II</b>	
<b>SURVEYING</b>	
<b>Topographic Survey</b> . . . . .	193
Sample Notes . . . . .	193
Stadia Tables . . . . .	195
<b>Construction Stakeouts</b>	
Stakeout for Structures . . . . .	197
Highway Construction Stakeout . . . . .	198
Railroad Construction Stakeout . . . . .	199
Airfield Construction Stakeout . . . . .	200
Pipeline Stakeout . . . . .	201
<b>Circular Curves</b>	
Arc Definition . . . . .	202
Deflections . . . . .	203
Externals . . . . .	203
Minimum Curvature . . . . .	204
Maximum Curvature . . . . .	204
Tangent Offsets . . . . .	204
Chord Definition . . . . .	204
Radii, Deflections, Offsets, Ordinates, Chords and Arcs—100' Chords . . . . .	206
Minutes in Decimals of a Degree, Seconds in Decimals of a Minute . . . . .	207
Functions of 1° Curve . . . . .	208
Corrections for Tangents and Externals . . . . .	209
Deflections and Chord Lengths for Circular Curves . . . . .	210
Lengths of Circular Arcs for Unit Radius . . . . .	211
Metric Curves . . . . .	212
Short-Radius Curves . . . . .	213
Deflections ( $d$ ) and Middle Ordinates ( $m$ ) for Subchords . . . . .	215
Formulas for Areas . . . . .	216

CONTENTS

xiii  
PAGE

<b>Transition Curves</b>	
Circular Curves with Spiral Transitions . . . . .	217
Spiral Layout . . . . .	218
Minimum Transition Lengths . . . . .	219
General Problems . . . . .	220
Properties of Spiral . . . . .	221
Layout of Control Points . . . . .	223
Functions of Transition for $L_s = 1$ . . . . .	224
Functions of Curves Transitional Throughout—Tangents and Ex- ternals for $L_s = 1$ . . . . .	225
Spiral Layout by Offsets or Deflections . . . . .	226
<b>Vertical Curves</b>	
Vertical Summit Curve . . . . .	227
Vertical Sag Curve . . . . .	228
Symmetrical Vertical Curves . . . . .	228
Unsymmetrical Vertical Curves . . . . .	229
Parabolic Crown Ordinates . . . . .	229
<b>Railroad Turnouts and Crossovers</b> . . . . .	233
<b>Earthwork Computations</b>	
Methods of Finding Areas . . . . .	234
Methods of Finding Volumes . . . . .	234
Double End Area Volumes . . . . .	236
Prismoidal Corrections for $L = 100'$ Stations . . . . .	240
<b>Leveling</b>	
Sample Notes . . . . .	242
<b>Transit Problems</b>	
Determination of Distance to Inaccessible Point . . . . .	243
Angles by Repetition . . . . .	243
Laying off Angles by Repetition . . . . .	244
Area by Double Meridian Distance . . . . .	244
Omitted Side . . . . .	247
Prolongation of a Line by Double Sighting with Transit (Double Centering) . . . . .	248
Establishing a Line by Balancing-in with Transit (Bucking-in) . . . . .	248
Layout of Circular Curve . . . . .	249
Sample Notes . . . . .	250
<b>Allowable Errors</b>	
Leveling . . . . .	250
Distances . . . . .	251
Transit and Tape Traverses . . . . .	251
<b>Determination of True North</b>	
Observation on Polaris . . . . .	252
Isogonic Chart . . . . .	254
<b>Instruments and Their Adjustments</b>	
Parts of Gurley Precise Transits . . . . .	256
Parts for Gurley Dumpy Levels . . . . .	257



	PAGE
Parts for Gurley Wye Levels . . . . .	258
Hints on Adjustments . . . . .	259
Transit Adjustments . . . . .	260
Adjustments of Wye and Dumpy Levels . . . . .	268
<b>Taping</b> . . . . .	<b>276</b>
<b>Mapping</b>	
Plotting Traverses . . . . .	277
Plotting Topography . . . . .	279
Mapping Symbols . . . . .	280
<b>General Tables and Information</b>	
Land Measure . . . . .	283
Trigonometric Formulas . . . . .	283
Natural Trigonometric Functions . . . . .	289
Logarithmic Trigonometric Functions . . . . .	292
Minutes into Decimals of a Degree . . . . .	293
Logarithms of Numbers . . . . .	294
Decimal Equivalents of Common Fractions . . . . .	296
Surveying Signals . . . . .	297
<b>Index</b> . . . . .	<b>299</b>

**PART I**  
**INSPECTION**



# TYPICAL HEAVY CONSTRUCTION EQUIPMENT

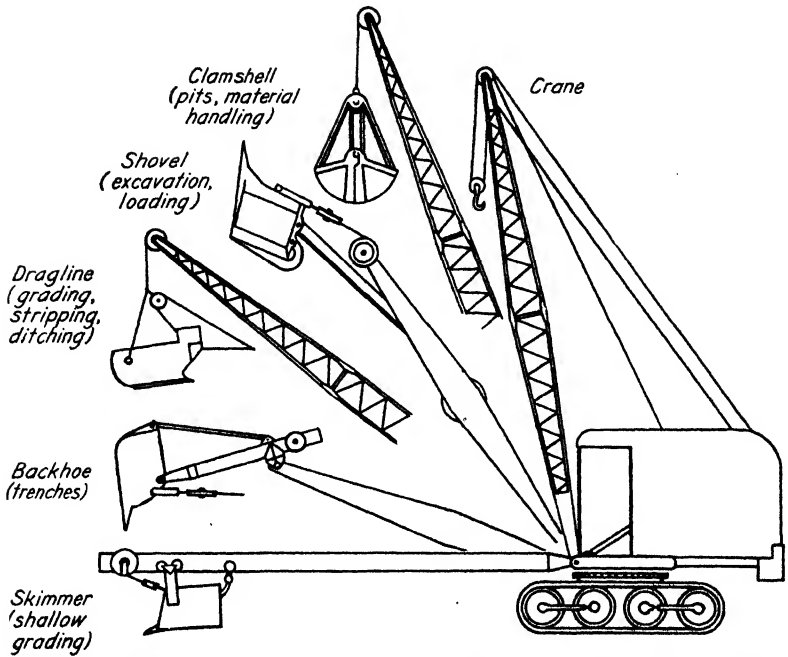

FIG. 1. Lorain crane with attachments. *Courtesy of the Thew Shovel Company.*

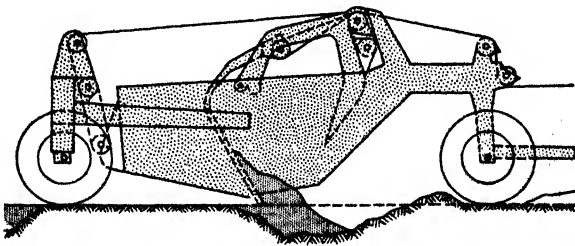

FIG. 2. Four-wheel scraper. (Earth-moving, grading, excavation.) *Courtesy of Bucyrus-Erie Company.*

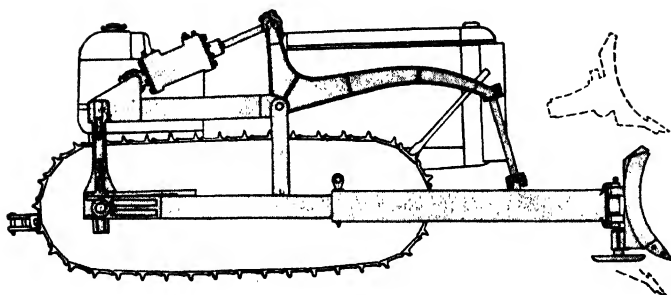

FIG. 3. Bulldozer. (Clearing, stripping, grading, earth-moving.) *Courtesy of Bucyrus-Erie Company.*

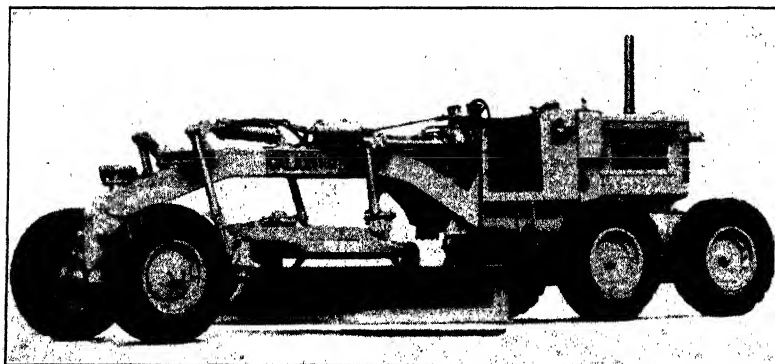

FIG. 4. Motor grader "motor patrol." (Shaping subgrades and surfaces, soil mixing.) *Courtesy of the Galion Iron Works and Manufacturing Company.*

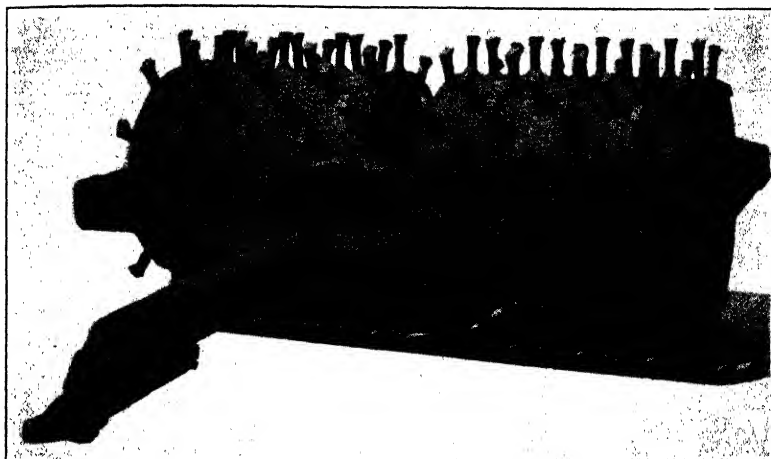

FIG. 5. Tamping roller "sheepsfoot." (Compacting fills.) *Courtesy of the Baker Manufacturing Company.*

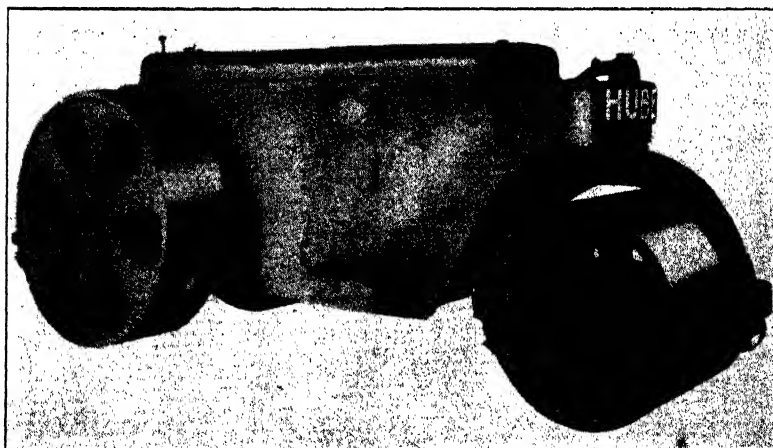

FIG. 6. Eight-ton three-wheel roller. *Courtesy of Huber Manufacturing Company.*

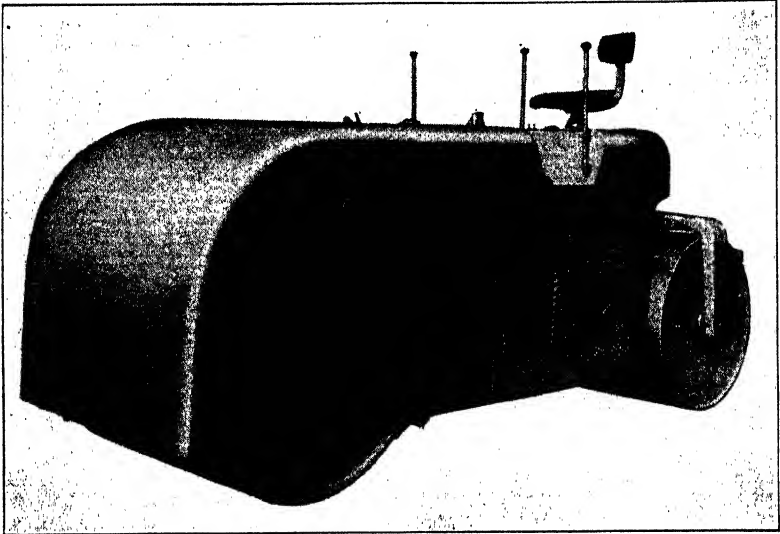

FIG. 7. Five- to eight-ton tandem roller. *Courtesy of Huber Manufacturing Company.*

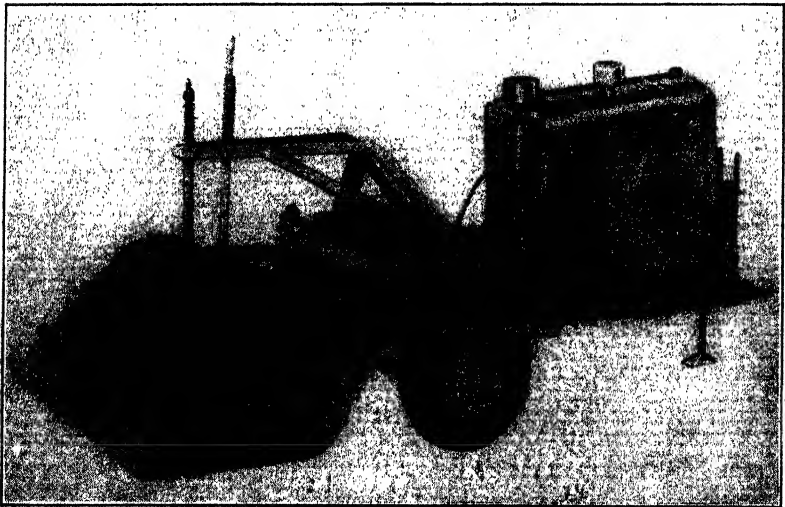

FIG. 8. Pulvi-Mix. (Mixing earth and stabilising agents—pulverizing.) *Courtesy of Seaman Motors.*



FIG. 9. Trencher. (Trench excavation in earth.) *Courtesy of the Parsons Company.*

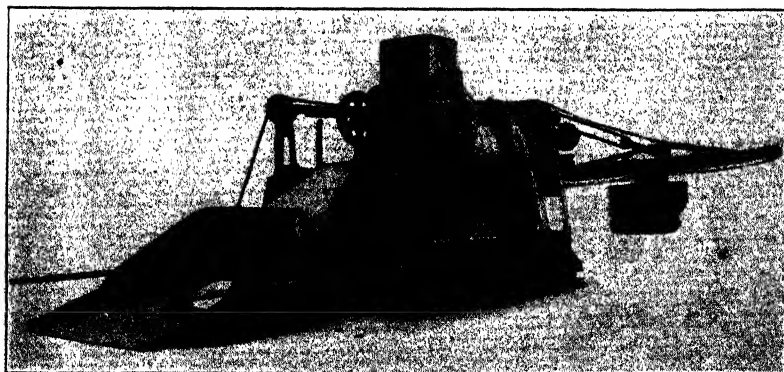

FIG. 10. Concrete paver. *Courtesy of Ransome Machinery Company.*



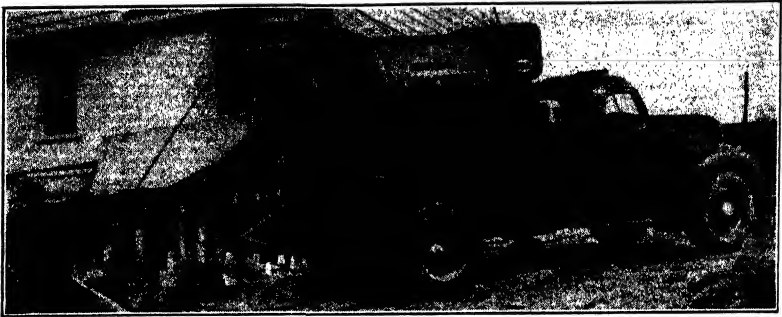

FIG. 11. Rex transit-mix truck. *Courtesy of Chain Bell Company.*

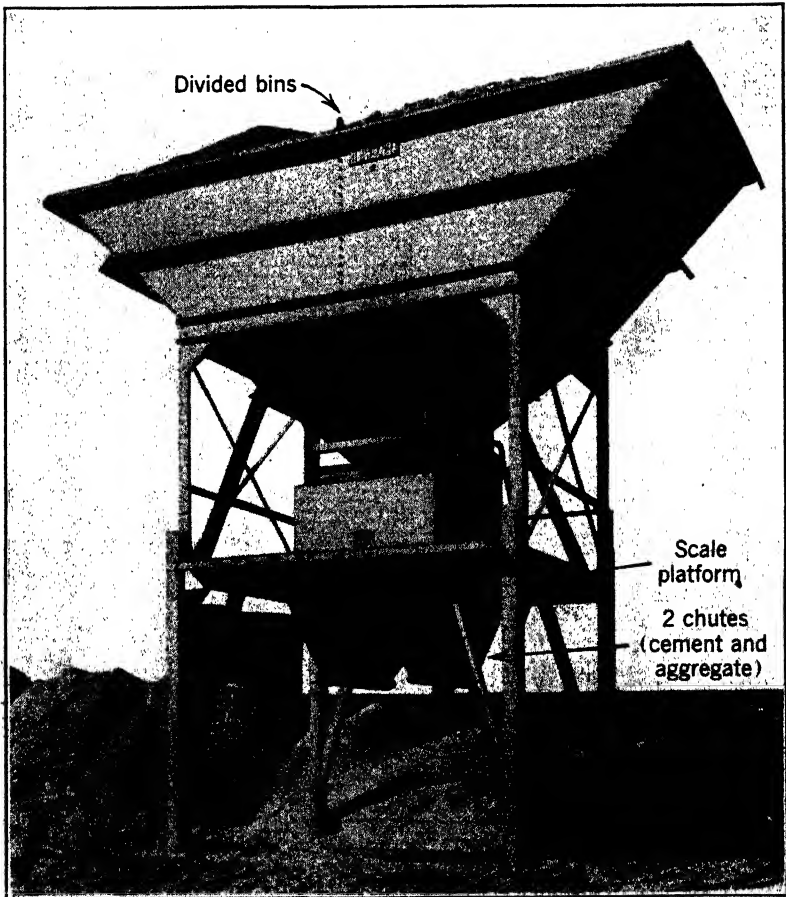

FIG. 12. Aggregate batching plant. *Courtesy of Blaw-Knox Company.*



FIG. 13. Finishing machine for roads and airports. *Courtesy of Blaw-Knox Company.*

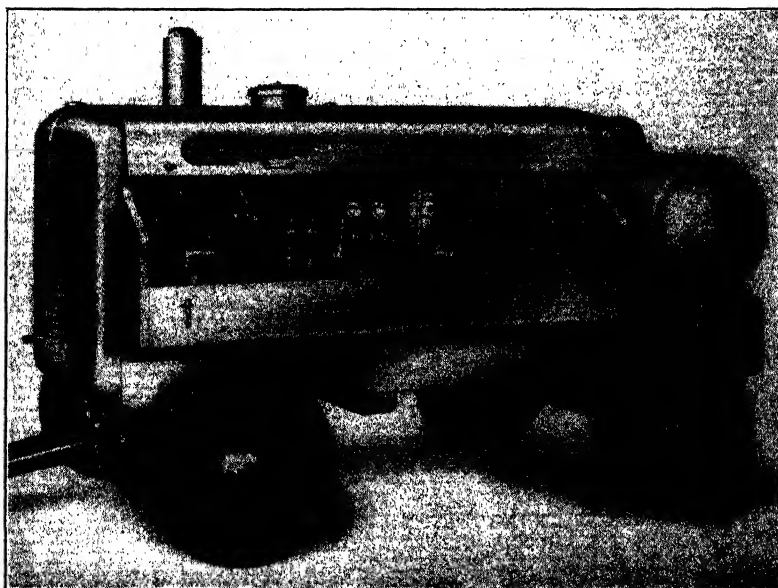

FIG. 14. Compressor. *Courtesy of the Jaeger Machine Company.*

**CONCRETE  
FIELD SAMPLING**

Material and Method	When Sampled	Size of Sample	Instructions
Cement, A.S.T.M. C-77	Each 1600 sacks or 400 bbl.	8 lb. min.	Sacked cement: compose sample from portions taken from 1 sack in 40. Bulk cement: sample from different locations with small scoop. Ship in container sealed airtight with paraffin.
Aggregates, A.S.T.M. D-75	Each source First shipment and if any change	Sand, 30 lb. Stone and slag, 100 lb. Gravel, 100 lb. over 1/2-in. size	Quarter aggregates by placing on canvas square or clean surface. Mix thoroughly. Form into conical pile. Flatten pile. Cut into 4 pie-shape parts. Discard 2 opposite quarters including dust. Remainder. Repeat till desired size, but not less than twice. Ship in strong, tight bag or box.
Steel Reinforcement, A.S.T.M. A-15, 16, or 160	Each 10 tons Each lot or shipment	3 pieces of each size, 18 in. long min.	Wire pieces together and wrap in burlap.
Bar or rod mats, A.S.T.M. A-184	Each order or each 500 mats	2 ft. by 2 ft.	Cut sample from 2 mats in each order. Ship crated.
Wire fabric, A.S.T.M. A-185 and A-82	Each order or each 75,000 sq. ft.	2 ft. by 2 ft.	If heavy edge wire type include edge in square. Ship crated.
Expansion joint filler, A.S.T.M. D-545	Each 1000 sq. ft.	3 ft. long min. by full depth	Ship crated. Seal cork type in waterproof paper.
Joint sealer, A.A.S.H.O. M-18	Each lot or shipment	1 qt. min.	Place in friction lid can. Ship crated or boxed.
Curing liquids, A.S.T.M. C-156	Each lot or shipment	1 qt. min.	Ship in small-mouth can with cork-lined screw top.

Concrete test cylinders, A.S.T.M. C-31	As specified, or 4 for each 250 cu. yd. or 2000 sq. yd. of slabs	6 in. dia. by 12 in. high for aggregate 2 in. and under; 8 in. dia. by 16 in. high for aggregate over 2 in.	Use paraffined cardboard or metal mold. Place sample in mold in 3 equal layers, rodding each layer 25 strokes with $\frac{3}{8}$ in. by 24 in. bullet pointed rod. Strike off top with trowel. Cover and keep moist at 60°-80° F. Do not move for 24 hr., then remove molds and paint identification on cylinder. Cure laboratory control cylinder moist at 70° F. till tested. Cure field control cylinders same as corresponding concrete. Pack in wet sawdust or burlap, and ship in strong box.
Concrete test beams, A.S.T.M. C-78	3 or 4 beams for every 2000 sq. yd. of pavement or slab	6 in. by 6 in. by 30 in. or 36 in.	Use rigid wood or metal form (6-in. channels) lightly oiled or paraffined. Place concrete in 2 equal layers, each layer rodded 50 times per sq. ft. Spade sides and edges with trowel, and strike off top. Finish with cork float. Cover at once with damp burlap. After 24 hr. remove forms and cure moist at 60° to 75° F. for laboratory control. Paint identifying marks or symbols. Cure field control beams same as corresponding concrete. Pack in wet sawdust or burlap, and ship in strong box.
Calcium chloride, A.S.T.M. D-98	Each lot or shipment	1 qt. min.	Ship in airtight container.
Water, A.A.S.H.O. T-26	Each source	2 qt.	Ship in crated glass jar with glass stopper.

## MARKING SAMPLES—ALL MATERIALS

Place one tag inside container, and attach one tag firmly outside. Record all shipments and data in field book. Mark tags with name and address of laboratory; date; project; contractor; engineer; sampler; quantity represented; any special test desired if other than routine; vendor's or manufacturer's name and brand name if any; location or part of structure affected; sample number; address to send report; any other pertinent information. See Fig. 17 for sample tag.

**Cement.** Railroad car number; sacked or bulk; type; mill.

**Aggregates.** Kind; quantity in source; name of plant pit or quarry, and location.

**Reinforcing.** Lot number; markings on rods.

**Test Cylinders and Beams.** Date molded; station or location in structure; mix proportions;  $W/C$  ratio, gallons per sack; cement, sacks per cubic yard; slump; unit weight, pounds per cubic foot; cement brand, type, mill, and car number; type and source of aggregate, by whom made.

*Note.* Use envelope-style tags with name and address of laboratory and shipper on envelope and complete data on tag or card inside envelope tag.

## FIELD TESTING

**Slump Test for Consistency, A.S.T.M. C-143.** Use a standard slump cone made of No. 16 gage galvanized metal in the form of a frustum of a cone with the base 8 in. in diameter, the top 4 in. in diameter, and the altitude 12 in. Provide mold with foot pieces and handles.

Take 5 samples of concrete, and thoroughly mix to form test specimen. Sample from discharge stream of mixer, starting at beginning of discharge and repeating until batch is discharged. For paving concrete, samples may be taken from the batch deposited on the subgrade. Before placing concrete, dampen the cone and place on a flat, moist, non-absorbent surface. In placing each scoopful of concrete move the scoop around the top edge of the cone as the concrete slides from it, in order to insure symmetrical distribution of concrete within the cone. Fill the mold in 3 equal layers, rodding each layer with 25 strokes of a  $\frac{5}{8}$ -in.  $\phi$  rod 24 in. in length, bullet pointed at the lower end. Distribute the strokes in a uniform manner over the cross section of the cone and penetrate into the underlying layer. Rod the bottom layer throughout its depth. After the top layer has been rodded strike off the surface of the concrete with a trowel or board so that the cone is exactly filled. Immediately remove the cone from the concrete by raising it carefully in a vertical direction. Then measure the slump immediately by laying the 24-in. rod across the top of the cone and measuring down to the top of the sample. This is known as the slump, which is equal to 12 in. minus the height in inches, after subsidence, of the concrete specimen. The slump test should be made frequently, at least 3 or 4 times a day.

**Unit Weight of Plastic Concrete, A.S.T.M. C-138.** Use a calibrated bucket of minimum No. 11 gage metal, a  $\frac{5}{8}$ -in. by 24-in. bullet-pointed rod, and a scale accurate to 0.5% of total weight tested. Capacity of bucket should be  $\frac{1}{10}$  cu. ft. for  $\frac{1}{2}$ -in. maximum aggregate;  $\frac{1}{2}$  or  $\frac{1}{3}$  cu. ft. for 2-in. maximum aggregate, and 1 cu. ft. for 4-in. maximum aggregate. Place a representative sample (selected as described for slump test above) in the bucket in 3 equal layers, rodding each layer 25 strokes as described for slump test. Vibrated concrete shall be compacted in the measure by vibration. Strike off surface, taking care that measure is just level full. Weigh to nearest 0.1 lb., subtract weight of bucket, and compute net weight of concrete in pounds per cubic foot.

*Note.* It is suggested that the inspector carefully sample about 1 cu. ft. or more of concrete and run slump test, unit weight test, and mold cylinders and beams in one sequence of operations. Complete data will then be obtained.



COPYRIGHT, 1942  
AMERICAN SOCIETY FOR TESTING MATERIALS  
1916 RACE ST., PHILADELPHIA 3, PA.

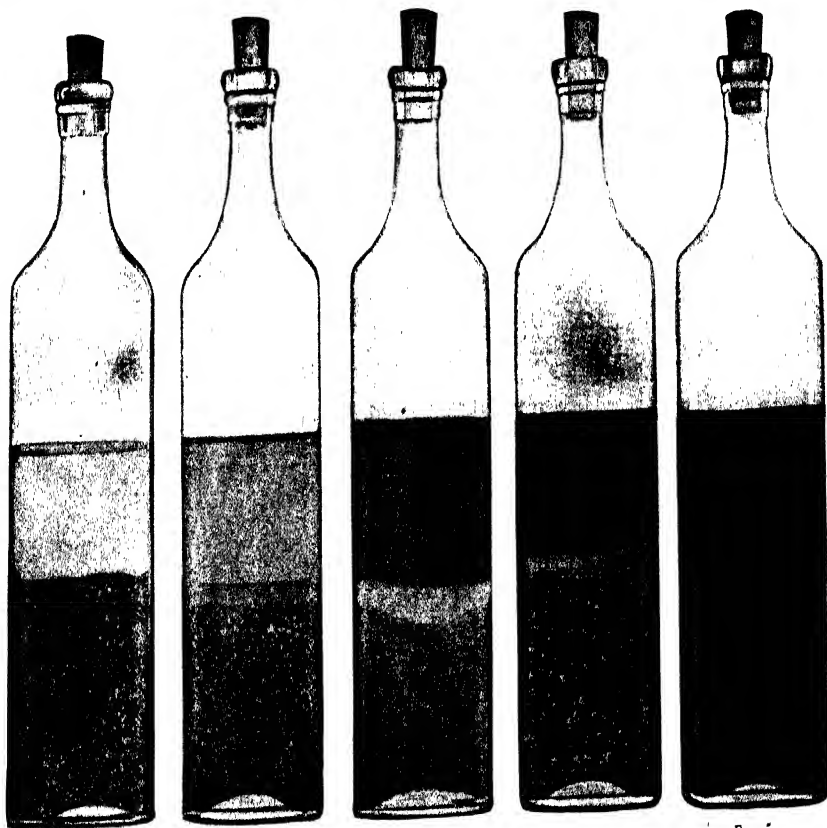

FIG. 1

FIG. 2

FIG. 3

FIG. 4

FIG. 5

Sands suitable for use  
in high-grade concrete.

Sands which may be  
used in unimportant  
concrete work.

Sands which should  
never be used in  
concrete.

An unusually bad  
sand, soil, or loam.

FIG. 15. Colors of Treated Sands with Suggested Ranges of Application.



**Correct**  
Methods which place material in the pile in individual units not larger than a truck load and which do not permit the aggregate to run down the slopes at the edge of the pile.



**Incorrect**  
Methods which permit the aggregate to roll down the slopes as it is added to the pile.

### STOCKPILING OF SCREENED AGGREGATE (WHEN PERMITTED)

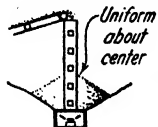

Openings provided as required to discharge materials at various elevations on the pile.

**Correct**  
Chimney surrounding material falling from end of conveyor belt to prevent wind from separating fine and coarse materials.

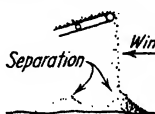

**Incorrect**  
Free fall of material from high end of stacker permitting wind to separate fine from coarse material.

### UNFINISHED OR FINE AGGREGATE STORAGE (DRY MATERIALS)

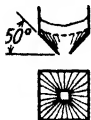

**Correct**  
Full bottom sloping 50° from horizontal in all directions to outlet with corners of bin properly rounded.

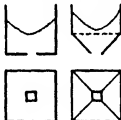

**Incorrect**  
Flat-bottom bins or those with any arrangement of slopes having corners or areas such that all material in bins will not flow readily through outlet without shoveling.

### SLOPE OF AGGREGATE BIN BOTTOMS



**Correct**  
Material drops vertically into bin directly over the discharge opening permitting discharge of more generally uniform material.



**Incorrect**  
Chuting material into bin on an angle. Material falling other than directly over opening not always uniform as discharged.

### FILLING OF AGGREGATE BINS

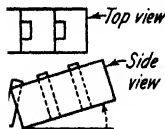

**Correct**  
Provides separate compartments of suitable size and depth, attached to and operating with each batch release gate.

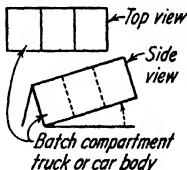

**Incorrect**  
Cement dumped on or within aggregate may be blown away, partially prehydrated, or may slide into another batch in dumping.

### PROVISION FOR CEMENT IN DRY-BATCH COMPARTMENTS

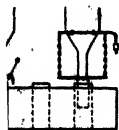

**Correct**  
Fall of cement controlled by enclosing in kinked canvas drop chute or telescopic flexible hose tremie.

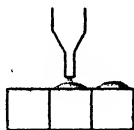

**Incorrect**  
Free fall of cement into batch car or truck causes waste, and overlap of batches is common.

### LOADING CEMENT FROM BATCHER

## CHECK LIST FOR INSPECTORS

### CONCRETE—GENERAL

#### Inspectors' Equipment

Complete set of plans and specifications and approved set of reinforced-concrete working drawings.

Supply of required forms, sample tags, bags and boxes for samples.

Balance, capacity 2 kg., sensitive to 0.1 gram.

Set of square-mesh sieves of specified aggregate sizes and cleaning brush.

Fruit jar pycnometer, Chapman flask or hot plate and pan for moisture content of aggregates.

12-oz. graduate bottle and 1 lb. of sodium hydroxide (caustic soda) for colorimetric test.

Pint milk bottle for silt and clay test.

6 in. by 12 in. metal or paraffined cardboard molds for concrete test cylinders and shipping boxes for same.

Slump cone,  $\frac{5}{8}$  in. by 24 in. tamping rod, and mason's trowel.

$\frac{1}{3}$  or  $\frac{1}{2}$  cu. ft. calibrated bucket and scale for unit weight tests, when specified.

Thermometer similar to Weston All-Metal type, 0 to 180° F. for cold-weather concreting.

6-ft. rule and 50-ft. steel tape.

Plumb bob and marking keel.

Field book and pencils for records and diary.

JOB.....	DATE.....	BEAM CYL. NO.
CONC. FOR.....		1 OF.....
TEMP. ....	WEATHER.....	
BATCH NO. ....	SLUMP.....	
MIX.....	UNIT WT. ....	W/C.....
REMARKS.....		
ENGINEER.....	TAKEN BY.....	

FIG. 17. Cloth tag for attaching to concrete test beams or cylinders.



### Procedure in Inspection

**Tested and Approved Materials.** Cement, aggregates, reinforcing steel, and water tested and source approved before use.

Schedule of required field tests adhered to.

Prompt shipment of samples of materials delivered at site.

Prompt reporting of field tests.

Accurate and complete daily reports and records.

Removal of rejected materials from site of work.

**Storage and Handling of Materials.** Aggregates stockpiled in 2-ft. to 4-ft. layers on mats or planking.

Aggregate segregation avoided; see Fig. 16.

Cement protected from moisture and weather.

Cement handled to avoid loss by blowing or leakage, see Fig. 16.

Reinforcing steel protected from rusting, bending, or distortion and kept free from oil or grease.

### Batch Plant Inspection

**Batching Plant.** Inspected and approved before use.

Daily check of weighing scales, accurate to tolerance of 0.004.

Use ten 50-lb. weights, check in 500-lb. increments to greatest batch weight or have scales checked and sealed by certified scale master.

Adequate visibility of weighing and batching.

Telltale dial or balance indicator for correct quantities in hoppers.

Positive shut-off for bulk cement.

Prompt removal of excess material in hoppers.

Protection for weighing equipment from dust or damage.

Oscillating beams normally horizontal with equal play.

Beam scale for each aggregate usually required.

**Control of Concrete.** Determine percentage of surface moisture in aggregates.

Check at least 3 times daily, or more often when slump of concrete or condition of aggregate changes.

Translate the design into batch weights, see p. 34.

Run trial batch to check on slump and unit weight of mixture.

Check on cement factor during operations to detect bulking due to voids, air entrainment, or batching inaccuracies.

Adjust batch weights to produce required cement content per cubic yard and yield of concrete per batch.

Check actual amount of cement used to concrete laid each day as check on dimensions of concrete and accuracy of batching.

*Note. The inspector should not vary the mix furnished by the laboratory without authority from the project or resident engineer.*

**Transporting Materials.** Record of batch weights and number of batches dispatched; check with mixer inspector daily.

Tight truck partitions high enough to prevent intermingling of aggregates and loss of cement. Separate cement partitions, when specified.

Required amount of cement placed in batch partitions.

Covers for batch trucks provided.

Cement carried in sacks if specified.

### Field Inspection

**Forms.** Correct alignment and elevation.

Centering true and rigid with horizontal and diagonal bracing.

Tight enough to prevent mortar leakage.

Columns plumb, true, and cross braced.

Floor and beam centering crowned  $\frac{1}{4}$  in. per 16 ft. of span.

Beveled chamfer strips at angles and corners.

Inside of forms oiled or wetted. Oil applied before placing of reinforcing.

Check installation of bolts, sleeves, inserts, and embedded items against plan details.

Check cleaning and removal of debris through temporary openings.

Check slab depths, beam and column sizes.

**Removal of Forms and Shoring.** Record of date forms poured and date forms removed.

Forms not removed until concrete is set, should ring under a hammer blow; follow job specifications.

Reshores placed after forms removed.

Forms removed carefully, damage to green concrete avoided.

Inspect surface at once after form removal. Notify superior of serious defects.

**Reinforcing Steel.** Clean and free of scale, oil, and defects. Can be rubbed down with burlap sacks or wire brushes.

Accurately fabricated to plan dimensions.

Supports rigid, metal preferable; do not allow use of rocks, brickbats, old concrete fragments, etc., to support steel.

Check minimum clear spacing between bars;  $1\frac{1}{2}$  diameters for round bars and 2 times side dimension for square bars.

2-in. cover for steel in exposed exterior surfaces or as specified or detailed.

Check, from working drawings, the quantity, size, placing, bending, splicing, and location of reinforcing.

Check prebent steel against bending schedule upon delivery.

**Mixing Concrete.** Mixer in good condition and kept clean of hardened concrete.

Mixer blades not worn, and drum watertight.

Check drum speed, usually 200 to 225 peripheral feet per minute.

Check mixing time frequently; should be 1 to 1½ minutes minimum.

No retempering of concrete. Mixer completely emptied before starting new batch.

Adherence to specified water content. Amount of mix water based on moisture content of aggregates obtained from batch plant inspector and correct amount added at mixer.

Check consistency; make slump test at least 2 or 3 times daily.

Check for full cement content in each batch if cement is batched at mixer.

**Ready-Mixed Concrete, Transit Mixers.** Strict adherence to job specifications.

Calibration of water-discharge mechanism plainly marked.

Error in water measurement should not exceed 1%.

Leakage in valves; should be tight when closed.

Drums should be watertight. Check specified revolutions, usually 50 to 150 allowed for mixing.

Number, arrangement, and dimensions of mixer blades checked against manufacturer's statement. Blades not worn more than 15% of stated width.

Main water tank provided against loss by leakage or surging. To discharge full volume for mixing in not more than 5 minutes.

Volume of concrete mixed not more than 58% gross volume of drum. (If concrete is central mixed and only transported in truck mixers, 80% of volume is usually allowed.)

All truck mixers inspected and approved.

Complete removal of wash water or remaining concrete after each mixer discharge.

Wash water transported in auxiliary tank with gage and watertight valve.

Adherence to specified mixing time and any restrictions on mixing en route.

Drum to be revolved during transfer of water into drum.

Adherence to correct amount of water. Inspector should approve adding additional water. If necessary to add water to discharge, dry cement should be added at required *W/C* ratio.

Concrete containing air-entraining agent not to be mixed en route.

For transit trucks the time of mixing should be from 5 minutes to 15 minutes or more, increasing with the volume of the truck and depending on the condition of the blades and whether or not it is a high dump truck.

**Placing of Concrete.** Forms inspected and approved before concreting.

Steel reinforcing in place and inspected.

Earth under footings to be undisturbed, original soil.

Rock or ledge should be well cleaned off, washed, and with no dirt or loose rock fragments.

Footings shall be free from standing water.

Avoid segregation, rehandling or flowing.

Place each unit continuously, if possible, till completed.

Spading and vibrating to maximum subsidence without segregation and next to forms and joints.

Reinforcing bars shaken to insure bond with concrete.

Accumulated water removed; concrete not placed therein.

Avoid excessive vibration and manipulation.

In thin high sections avoid having concrete stick and harden on steel and forms above placing level.

Mold required number of test cylinders each day. See p. 11.

See that wood form spreaders are knocked out and not buried as concrete is placed.

Concrete placed as close to final position as possible in continuous horizontal layers.

Concrete not placed in or under water unless as specially specified or directed by engineer.

**Construction Joints.** Avoid if possible, or place as detailed on plans.

If necessary at end of day's pour, install plumb, at right angles to plane of stress and in area of minimum shear.

Check on placing of dowels, keys, waterstops, and other details as shown on plans.

**Floors.** Check and remove laitance when concrete reaches required level. If excessive, cut down on mix water or overworking of concrete.

Finish floor as specified.

**Pumping and Conveying.** Only if approved or specified.

Equipment cleaned before and after pouring.

Continuous flow of concrete; no segregation.

**Exposed Surfaces.** Retain original surface film and form marks; do not rub.

Fins and projections removed.

Small voids filled with 1:2 mortar.

Construction joints only as detailed on plans.

Metal ties, chairs and spacers covered with 1½ in. of concrete.

**Curing Concrete.** Kept moist for 1 week minimum or sprayed with approved preparation.

Continuous saturation by sprays or wet fabric is preferred to intermittent sprinkling by hand. On vertical surfaces see that wet fabric is kept in contact with concrete.

Prompt application of curing materials as soon as possible after finishing concrete.

**Cold-Weather Concreting.** Do not heat cement. Aggregates and/or water heated to not over 175° F. No snow or frozen lumps in aggregate.

Check temperature of concrete as placed, not less than 60° F. or more than 100° F. Use immersion thermometer inserted in concrete near forms or surface.

Ice and snow removed from forms, place of deposit and reinforcement before placing concrete.

**Frost Protection.** Provided by full enclosure of concrete and temperature of not less than 60° F. maintained for 7 days or as specified. Keep humidity high in enclosure.

*Or*, by consent of engineer, provided by protecting surface with straw, hay, or fabric for 7 days. In buildings enclose story below and heat to 50° F. for 7 days.

Temperature protection gradually removed to prevent sudden freezing of concrete.

**Accelerating Admixtures** (Calcium Chloride). Use only if specified. Tested before use.

Delivered in moisture-proof bags or airtight drums.

Quantity used not over 2 lb. per sack of cement.

Dissolve 1 lb. per quart of water, and add not more than 2 qt. per sack of cement to mixing water. Subtract amount of solution from normal quantity of mixing water.

Dry calcium chloride not to be added to aggregate in mixer skip or placed in contact with dry cement.

For cold-weather placing and curing, provide same precautions as for plain cement.

**High-Early-Strength Cement.** Use only if specified. Mixing and placing same as standard cement.

Prompt finishing (delay will ruin finish).

Curing temperature maintained as specified (usually 70° F. for 2 days or 60° F. for 3 days).

**Load Tests.** May be required for faulty workmanship, violation of specification, or concrete suspected of having been frozen.

Notify superiors if necessary.

### **Pay Items**

Accurate record kept of all pay items in contract, such as:

Volume of concrete placed and batches wasted.

Volume of openings or embedded structures if payment for such is not made.

Amount of reinforcing steel in pounds or tons actually placed.

Number and length of extra dowels and dowel holes drilled.

Embedded items or structures.

Any other contract pay items.

## CHECK LIST FOR INSPECTORS

### CONCRETE—PAVING

#### Procedure in Inspection

It is assumed that batching has been performed and inspected; see p. 14. For transit-mix concrete, see p. 16.

#### Field Inspection

**Subgrade.** Drainage, stability, compaction. Wet down ahead of placing. Moist, not muddy.

Grade and cross section. Full depth of pavement at all points.

Check ordinates to subgrade templates and scratch boards.

**Forms.** Approved type with true face, top, and base.

Connections rigid and true.

Alignment and grade.

Staked solidly with adequate base support.

Cleaned and oiled each time used.

**Reinforcing and Joint Assemblies.** Tested and approved reinforcing steel placed to secure final position shown on drawings.

Transverse joint assemblies at correct locations staked solidly. Accurate to line and perpendicular to subgrade. Joint material tight against forms or adjacent joint.

Approved dowels, painted and greased, held rigidly parallel to surface and axis of pavement. Correctly spaced. Approved expansion caps in place.

Correctly aligned longitudinal joints with correctly spaced tie bars held securely in place, normal to joint and parallel to surface.

**Mixing and Placing Concrete.** Full cement content of batch. Empty bags and count at end of each run to check cement factor. Provide against loss of bulk cement by blowing away.

Approved mixer with accurate timing and bell. Provision to lock discharge lever until mixing time is complete. Mixer drum not loaded more than 10% above rated capacity (29.7 cu. ft. for 27-E paver).\*

Full mixing time for each batch after all ingredients are in drum. Check time frequently. Allow 1 minute minimum unless otherwise specified. Check specified revolutions of drum, usually 14 to 20 r.p.m., and peripheral speed.\*

\* Does not apply to transit-mix concrete.

Specified slump concrete, not too harsh or too wet. Concrete workable and plastic consistency. If not specified use following slumps: ordinary batch mixer, 1½ in. to 3 in.; if vibrated, 1 in. to 1½ in.; transit mixers, 2½ in. to 3 in. Use stiffest concrete that can be molded into forms and around reinforcing bars.

Thorough compaction of concrete. Spade or vibrate against forms and existing concrete. Do not vibrate or manipulate too much.

Daily check of cement content, yield, water cement ratio, adherence to design mix, aggregates, and cement used. Check of slump and unit weight, several tests daily.

Adequate protection at hand (burlap, cotton mats, tarpaulins, etc.), for sudden rain or drop in temperature. Assembled construction joint ready to install for stoppage over 30 minutes.

Uniform amount of concrete carried ahead of strike-off. Workmen to avoid walking on soft concrete or reinforcement assemblies. Deposit concrete in final position. Do not dump on joint assemblies.

**Finishing and Curing.** Surface finished at proper time with approved tools and appliances. Systematic checking with tested straightedge.

Ordinates checked to all screeds. For parabolic ordinates, see p. 229.

Overfinishing avoided, may produce scaling. High or low spots corrected.

Good workmanship on tooling of joints and edges; specified edge rounding radius and width of tooling.

Prompt application of approved curing agents. Curing for full period specified.

Care in removing forms and bending tie bars. Do not pry against green concrete.

Ample protection from traffic until cured.

**Sealing Joints, Opening to Traffic.** Careful cleaning and sealing of joints and cracks.

Final check for surface roughness, high joints, fractured slabs, flush sealing of joints. Correction and repair as directed.

Temporary shoulder for edge protection before traffic is allowed.

Adequate structural strength (usually flexural strength of 500 to 550 p.s.i. before opening). Test beams cured same as slab and broken by cantilever, center or ¼ point loading. (The latter is recommended.)

**Air-Entraining Cement.** Check for minimum and maximum air content; see specification. (Usually 3 to 6% of weight of a theoretical air-free mix.) Check with standard unit weight test using ¼ or ½ cu. ft. calibrated bucket; see p. 12. Excessive loss of weight may be due to following:

Overmixing of concrete. Check ready-mix and transit mix particularly.

High sand-aggregate ratio.

High water-cement ratio.

Air pressure in mixing drum of transit mixers. Leave discharge door partly opened and vent end of drum with four  $\frac{5}{8}$  in. diameter holes kept open at all times. Report excessive air content to engineer.

**Cold-Weather Concrete**

Concrete not placed on frozen subgrade.

Aggregate and water heated to produce temperature of concrete, at placing, of 70° F. minimum and 100° F. maximum or as specified.

Curing temperature of 50° to 100° F. maintained for specified period.

No admixtures or extra cement used unless specified.

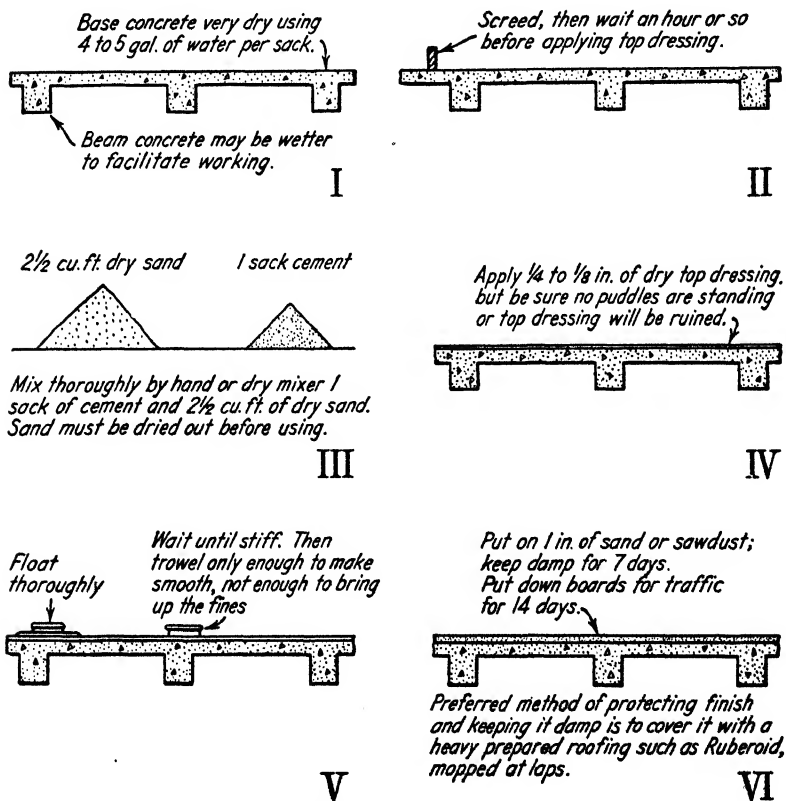
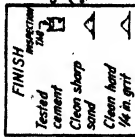
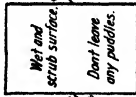
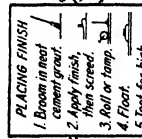
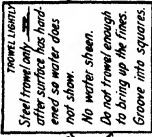
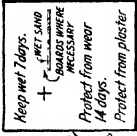
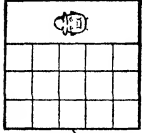
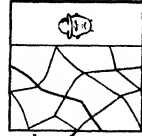
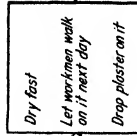
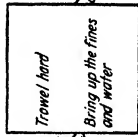
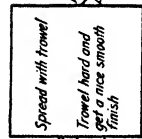
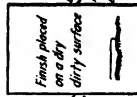
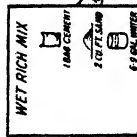
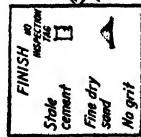
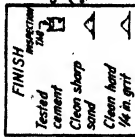
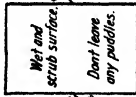
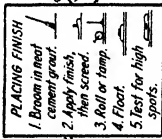
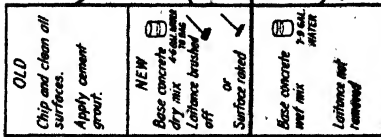

FIG. 18. Rules for construction of monolithic floor.



HOW TO DO IT



+ Preferred method of protecting finish and keeping it damp is to cover it with a heavy prepared roofing such as Ruberoid, same to be mopped at top.

2 to 3 gal. of water depending on amount of water in slab below.

HOW NOT TO DO IT

Fig. 19. Rules for construction of bonded cement finish floor.

## APPROXIMATE DATA ON CONCRETE MIXES

**TABLE 1. WATER-CEMENT RATIO (W/C) FOR VARIOUS STRENGTHS**

WATER CONTENT <i>Gallons per Sack of Cement</i>	CONTENT <i>W/C by Vol. Cu. Ft. per Sack</i>	W/C RATIO		STRENGTH OF CONCRETE	
		BY ABSOLUTE VOLUME	BY WEIGHT	AT 28 DAYS	
				<i>Compressive</i>	<i>Flexural</i>
5 max.	0.668	1.38	0.444	5000 p.s.i.	750 p.s.i.
6 max.	0.802	1.66	0.533	4000 p.s.i.	600 p.s.i.
7 max.	0.936	1.93	0.621	3200 p.s.i.	500 p.s.i.
8 max.	1.069	2.21	0.710	2500 p.s.i.	450 p.s.i.

*Note:* Strengths should be determined by trial mixes (when practicable) based on fixed W/C. To allow for field conditions the strength values shown in table should be reduced by about 20%.

**TABLE 2. RECOMMENDED CONSISTENCY OR SLUMP OF CONCRETE**

TYPE OF STRUCTURE	SLUMP IN INCHES	
	<i>Max.</i>	<i>Min.</i>
Reinforced foundation walls and footings	5	2
Plain footings and substructure walls	4	1
Slabs, beams, columns, and reinforced walls	6	3
Pavement and mass concrete	3	1

**TABLE 3. EXPOSED CONCRETE—MAXIMUM WATER CONTENT IN GALLONS PER SACK**

TYPE OR LOCATION OF CONCRETE	SEVERE AND MODERATE CLIMATE		MILD CLIMATE
At waterline (intermittent saturation)			
Sea water	5½		5½
Fresh water	6		6
Not at waterline but frequent wetting			
Sea water	6		6½
Fresh water	6½		7
Ordinary exposed structures	6½		7
Completely submerged			
Sea water	6½		6½
Fresh water	7		7
Concrete deposited through water	5½		5½
Pavement slabs on ground			
Wearing slabs	5½		6
Base slabs	6½		7

**TABLE 4. RECOMMENDED PER CENT OF SAND TO TOTAL AGGREGATE**

Crushed stone, max. 1½-in. size	38 to 42
Crushed stone, max. ¾-in. size	43 to 49
Gravel, max. 1½-in. size	36 to 40
Gravel, max. ¾-in. size	39 to 44

**Sand-Aggregate Ratio** or percentage by weight or volume of sand to total aggregate in mix should be from 33 to 45%, with extreme limits of 28 and 49%. The most economical mix will be that with lowest sand-aggregate ratio producing the desired plasticity, workability, and consistency.

### CONCRETE BATCHING

#### Quantities of Materials by Fuller's Rule

##### Batching by Volume—Aggregates Measured Damp and Loose.

$$\text{Cement factor or } C = \frac{42}{1 + s + g}$$

where  $C$  = sacks cement per cubic yard of concrete.

$s$  = cubic feet of sand per sack of cement.

$g$  = cubic feet of gravel or stone per sack of cement.

$$\begin{array}{l} \text{Volume of sand required per cubic yard of con-} \\ \text{crete, or } S \end{array} = 0.037Cs$$

$$\begin{array}{l} \text{Volume of gravel or stone required per cubic} \\ \text{yard of concrete, or } G \end{array} = 0.037Cg$$

$$\begin{array}{l} \text{Quantity of cement required per cubic yard} \\ \text{of concrete, in barrels} \end{array} = \frac{10.5}{1 + s + g}$$

**EXAMPLE.** Given: 1:2:4 mix by volume.

Required:  $C$ ,  $S$ , and  $G$ .

Solution:

$$C = \frac{42}{1 + 2 + 4} = \frac{42}{7} = 6 \text{ sacks cement required per cubic yard of concrete}$$

$$s = 0.037 \times 6 \times 2 = 0.44 \text{ cu. yd. of sand required per cubic yard of concrete}$$

$$G = 0.037 \times 6 \times 4 = 0.89 \text{ cu. yd. of stone or gravel required per cubic yard of concrete}$$

QUANTITIES FOR CONCRETE MIXES \*  
TABLE 5. 1-IN. GRAVEL USING NORMAL LEHIGH PORTLAND CEMENT

Sacks Cement per Cu. Yd.	Concrete Con- sistency	W/C Ratio, Gal. per Sack	Materials per Cubic Yard												Estimated Strength, Lb. per Sq. In.	
			By Weight						By Volume							
			Sand, Lb.	Gravel, Lb.	Water, Lb.	Added Water, Lb.	Sand, Cu. Ft.	Gravel, Cu. Ft.	Water, Gal.	Added Water, Gal.	7 Days	28 Days				
4	Wet	9.75	1520	1840	253	253	17.1	18.6	30.4	1200	2000					
4	Med.	9.00	1550	1880	226	226	17.4	19.0	27.1	1400	2300					
4	Stiff	8.25	1580	1920	200	200	17.8	19.3	24.0	1700	2700					
5	Wet	7.80	1420	1860	258	258	15.9	18.8	31.0	1900	2800					
5	Med.	7.20	1440	1900	231	231	16.2	19.2	27.7	2200	3200					
5	Stiff	6.60	1470	1940	205	205	16.6	19.6	24.6	2500	3600					
6	Wet	6.50	1320	1880	262	262	14.8	19.0	31.4	2500	3700					
6	Med.	6.00	1340	1920	236	236	15.1	19.4	28.3	2800	4000					
6	Stiff	5.50	1370	1960	210	210	15.4	19.8	25.2	3200	4400					
7	Wet	5.57	1220	1890	267	267	13.7	19.1	32.0	3100	4400					
7	Med.	5.14	1240	1930	241	241	14.0	19.5	28.9	3400	4800					
7	Stiff	4.71	1270	1970	215	215	14.3	19.9	25.8	3700	5200					

Based on Portland Cement Association Test Data. These figures are for moist curing at 70° F. For data on concrete for lower temperatures, see Table 13.

\* From Lehigh Portland Cement Company.

TABLE 6. 1-IN. GRAVEL USING LEHIGH EARLY-STRENGTH PORTLAND CEMENT

Sacks Cement per Cu. Yd.	Concrete Con- sistency	W/C Ratio, Gal. per Sack	Materials per Cubic Yard										Estimated Strength, Lb. per Sq. In.			
			By Weight					By Volume					1 Day	3 Days	7 Days	28 Days
			Sand, Lb.	Gravel, Lb.	Added Water, Lb.	Sand, Cu. Ft.	Gravel, Cu. Ft.	Added Water, Gal.								
4	Wet	9.75	1450	1910	256	16.3	19.3	30.7	500	1300	2000	2600				
4	Med.	9.00	1480	1940	230	16.6	19.6	27.6	650	1600	2300	2900				
4	Stiff	8.25	1510	1980	203	17.0	20.0	24.4	800	1900	2700	3300				
5	Wet	7.80	1350	1920	261	15.1	19.4	31.3	1000	2100	2800	3600				
5	Med.	7.20	1380	1960	234	15.5	19.8	28.1	1200	2400	3200	4100				
5	Stiff	6.60	1400	2000	208	15.8	20.3	25.0	1400	2800	3600	4500				
6	Wet	6.50	1250	1940	266	14.0	19.6	31.9	1500	2800	3700	4600				
6	Med.	6.00	1280	1980	239	14.3	20.0	28.7	1700	3100	4000	5000				
6	Stiff	5.50	1300	2020	213	14.6	20.4	25.6	1900	3400	4400	5500				
7	Wet	5.57	1150	1950	270	13.0	19.7	32.4	1800	3400	4400	5400				
7	Med.	5.14	1180	2000	244	13.2	20.2	29.3	2100	3700	4800	5800				
7	Stiff	4.71	1200	2040	218	13.5	20.6	26.2	2400	4000	5200	6200				

Based on Portland Cement Association Test Data. These figures are for moist curing at 70° F. For data on concrete for lower temperatures, see Table 13.

TABLE 7. 1-IN. STONE USING NORMAL LEHIGH PORTLAND CEMENT

Sacks Cement per Cu. Yd.	Concrete Con- sistency	W/C Ratio, Gal. per Sack	Materials per Cubic Yard						Estimated Strength,	
			By Weight			By Volume			7 Days	28 Days
			Sand, Lb.	Stone, Lb.	Added Water, Lb.	Sand, Cu. Ft.	Stone, Cu. Ft.	Added Water, Gal.		
4	Wet	9.75	1760	1610	241	19.8	16.3	28.9	1200	2000
4	Med.	9.00	1800	1640	214	20.2	16.6	25.7	1400	2300
4	Stiff	8.25	1830	1680	188	20.6	16.9	22.6	1700	2700
5	Wet	7.80	1650	1640	246	18.6	16.5	29.5	1900	2800
5	Med.	7.20	1680	1670	220	18.9	16.9	26.4	2200	3200
5	Stiff	6.60	1720	1700	193	19.3	17.2	23.2	2500	3600
6	Wet	6.50	1540	1660	251	17.3	16.8	30.1	2500	3700
6	Med.	6.00	1580	1690	225	17.7	17.1	27.0	2800	4000
6	Stiff	5.50	1610	1730	198	18.1	17.5	23.8	3200	4400
7	Wet	5.57	1440	1680	256	16.2	16.9	30.7	3100	4400
7	Med.	5.14	1470	1710	230	16.6	17.3	27.6	3400	4800
7	Stiff	4.71	1500	1750	203	16.9	17.7	24.4	3700	5200

Based on Portland Cement Association Test Data. These figures are for moist curing at 70° F. For data on concrete for lower temperatures, see Table 13.

TABLE 8. 1-IN. STONE USING LEHIGH EARLY-STRENGTH PORTLAND CEMENT

Sacks Cement per Cu. Yd.	Concrete Con- sistency	W/C Ratio, Gal. per Sack	Materials per Cubic Yard						Estimated Strength, Lb. per Sq. In.		
			By Weight			By Volume			1 Day	3 Days	7 Days
			Sand, Lb.	Stone, Lb.	Added Water, Lb.	Sand, Cu. Ft.	Stone, Cu. Ft.	Added Water, Gal.			
4	Wet	9.75	1690	1680	244	19.0	16.9	29.3	500	1300	2000
4	Med.	9.00	1730	1710	218	19.4	17.3	26.2	650	1600	2300
4	Stiff	8.25	1760	1740	191	19.8	17.6	22.9	800	1900	2700
5	Wet	7.80	1580	1700	250	17.8	17.2	30.0	1000	2100	2800
5	Med.	7.20	1620	1740	223	18.2	17.5	26.8	1200	2400	3200
5	Stiff	6.60	1650	1770	196	18.5	17.9	23.5	1400	2800	3600
6	Wet	6.50	1480	1720	255	16.6	17.4	30.6	1500	2800	3700
6	Med.	6.00	1510	1760	228	17.0	17.8	27.4	1700	3100	4000
6	Stiff	5.50	1540	1800	202	17.3	18.1	24.2	1900	3400	4400
7	Wet	5.57	1380	1740	259	15.5	17.6	31.1	1800	3400	4400
7	Med.	5.14	1410	1780	233	15.8	17.9	28.0	2100	3700	4800
7	Stiff	4.71	1440	1810	207	16.1	18.3	24.8	2400	4000	5200

Based on Portland Cement Association Test Data. These figures are for moist curing at 70° F. For data on concrete for lower temperatures, see Table 13.

TABLE 9. 2-IN. GRAVEL USING NORMAL LEHIGH PORTLAND CEMENT

Sacks Cement per Cu. Yd.	Concrete Con- sistency	W/C Ratio, Gal. per Sack	Materials per Cubic Yard										Estimated Strength, Lb. per Sq. In.	
			By Weight					By Volume						
			Sand, Lb.	Gravel, Lb.	Water, Lb.	Sand, Cu. Ft.	Gravel, Cu. Ft.	Water, Gal.	7 Days	28 Days				
4	Wet	9.00	1410	2010	233	15.8	20.3	28.0	1400	2300				
4	Med.	8.25	1440	2050	207	16.1	20.7	24.8	1700	2700				
4	Stiff	7.50	1460	2090	180	16.4	21.1	21.6	2000	3000				
5	Wet	7.20	1310	2030	238	14.7	20.5	28.6	2200	3200				
5	Med.	6.60	1330	2070	211	15.0	20.9	25.3	2500	3600				
5	Stiff	6.00	1360	2110	185	15.3	21.3	22.2	2800	4000				
6	Wet	6.00	1210	2040	242	13.6	20.6	29.0	2800	4000				
6	Med.	5.50	1230	2090	216	13.9	21.1	25.9	3200	4400				
6	Stiff	5.00	1260	2130	190	14.1	21.5	22.8	3500	4900				
7	Wet	5.14	1110	2060	247	12.5	20.8	29.6	3400	4800				
7	Med.	4.71	1140	2100	221	12.8	21.2	26.5	3700	5200				
7	Stiff	4.29	1160	2140	195	13.0	21.7	23.4	3900	5500				

Based on Portland Cement Association Test Data. These figures are for moist curing at 70° F. For data on concrete for lower temperatures, see Table 13.



TABLE 10. 2-IN. GRAVEL USING LEHIGH EARLY-STRENGTH PORTLAND CEMENT

Sacks Cement per Cu. Yd.	Concrete Con- sistency	W/C Ratio, Gal. per Sack	Materials per Cubic Yard						Estimated Strength, Lb. per Sq. In.		
			By Weight			By Volume			1 Day	3 Days	7 Days
			Sand, Lb.	Gravel, Lb.	Added Water, Lb.	Sand, Cu. Ft.	Gravel, Cu. Ft.	Added Water, Gal.			
4	Wet	9.00	1340	2080	236	15.0	21.0	28.3	650	1600	2300
4	Med.	8.25	1360	2120	210	15.3	21.4	25.2	800	1900	2700
4	Stiff	7.50	1390	2160	184	15.6	21.8	22.1	1100	2200	3000
5	Wet	7.20	1240	2100	241	13.9	21.2	28.9	1200	2400	3200
5	Med.	6.60	1260	2140	215	14.2	21.6	25.8	1400	2800	3600
5	Stiff	6.00	1290	2180	189	14.5	22.0	22.7	1700	3100	4000
6	Wet	6.00	1140	2110	246	12.8	21.3	29.5	1700	3100	4000
6	Med.	5.50	1160	2150	220	13.1	21.8	26.4	1900	3400	4400
6	Stiff	5.00	1190	2200	193	13.3	22.2	23.2	2200	3800	4900
7	Wet	5.14	1050	2120	250	11.8	21.4	30.0	2100	3700	4800
7	Med.	4.71	1070	2160	224	12.0	21.8	26.9	2400	4000	5200
7	Stiff	4.29	1090	2210	198	12.3	22.3	23.8	2600	4300	5500

Based on Portland Cement Association Test Data. These figures are for moist curing at 70° F. For data on concrete for lower temperatures, see Table 13.

TABLE 11. 2-IN. STONE USING NORMAL LEHIGH PORTLAND CEMENT

Sacks Cement per Cu. Yd.	Concrete Con- sistency	W/C Ratio, Gal. per Sack	Materials per Cubic Yard										Estimated Strength, Lb. per Sq. In.	
			By Weight					By Volume						
			Sand, Lb.	Stone, Lb.	Added Water, Lb.	Sand, Cu. Ft.	Stone, Cu. Ft.	Added Water, Gal.	7 Days	28 Days				
4	Wet	9.00	1660	1780	221	18.6	18.0	26.5	1400	2300				
4	Med.	8.25	1690	1810	195	19.0	18.3	23.4	1700	2700				
4	Stiff	7.50	1720	1850	168	19.3	18.7	20.2	2000	3000				
5	Wet	7.20	1550	1800	226	17.4	18.2	27.1	2200	3200				
5	Med.	6.60	1580	1840	200	17.7	18.6	24.0	2500	3600				
5	Stiff	6.00	1610	1870	173	18.1	18.9	20.8	2800	4000				
6	Wet	6.00	1440	1820	231	16.2	18.4	27.7	2800	4000				
6	Med.	5.50	1470	1860	205	16.6	18.8	24.6	3200	4400				
6	Stiff	5.00	1500	1900	178	16.9	19.2	21.4	3500	4900				
7	Wet	5.14	1340	1840	236	15.1	18.6	28.3	3400	4800				
7	Med.	4.71	1370	1880	210	15.4	19.0	25.2	3700	5200				
7	Stiff	4.29	1400	1920	183	15.7	19.4	22.0	3900	5500				

Based on Portland Cement Association Test Data. These figures are for moist curing at 70° F. For data on concrete for lower temperatures, see Table 13.

TABLE 12. 2-IN. STONE USING LEHIGH EARLY-STRENGTH PORTLAND CEMENT

Sacks per Cu. Yd.	Concrete Con- sistency	W/C Ratio, Gal. per Sack	Materials per Cubic Yard										Estimated Strength, Lb. per Sq. In.			
			By Weight					By Volume					1 Day	3 Days	7 Days	28 Days
			Sand, Lb.	Stone, Lb.	Added Water, Lb.	Sand, Cu. Ft.	Stone, Cu. Ft.	Added Water, Gal.	Sand, Cu. Ft.	Stone, Cu. Ft.	Added Water, Gal.					
4	Wet	9.00	1590	1840	224	17.8	18.6	26.9	17.0	18.9	27.6	650	1600	2300	2900	
4	Med.	8.25	1620	1880	198	18.2	19.0	23.8	17.0	19.2	24.4	800	1900	2700	3300	
4	Stiff	7.50	1650	1920	171	18.5	19.4	20.5	17.3	19.6	21.2	1100	2200	3000	3800	
5	Wet	7.20	1480	1870	230	16.6	18.9	27.6	16.6	18.9	27.6	1200	2400	3200	4100	
5	Med.	6.60	1510	1900	203	17.0	19.2	24.4	17.0	19.2	24.4	1400	2800	3600	4500	
5	Stiff	6.00	1540	1940	177	17.3	19.6	21.2	17.3	19.6	21.2	1700	3100	4000	5000	
6	Wet	6.00	1380	1890	234	15.5	19.0	28.1	15.5	19.0	28.1	1700	3100	4000	5000	
6	Med.	5.50	1400	1920	208	15.8	19.4	25.0	15.8	19.4	25.0	1900	3400	4400	5500	
6	Stiff	5.00	1430	1960	182	16.1	19.8	21.8	16.1	19.8	21.8	2200	3800	4900	5800	
7	Wet	5.14	1280	1900	239	14.3	19.2	28.7	14.3	19.2	28.7	2100	3700	4800	5800	
7	Med.	4.71	1300	1940	213	14.6	19.6	25.6	14.6	19.6	25.6	2400	4000	5200	6200	
7	Stiff	4.29	1330	1980	187	14.9	20.0	22.4	14.9	20.0	22.4	2600	4300	5500	6600	

Based on Portland Cement Association Test Data. These figures are for moist curing at 70° F. For data on concrete for lower temperatures, see Table 13.

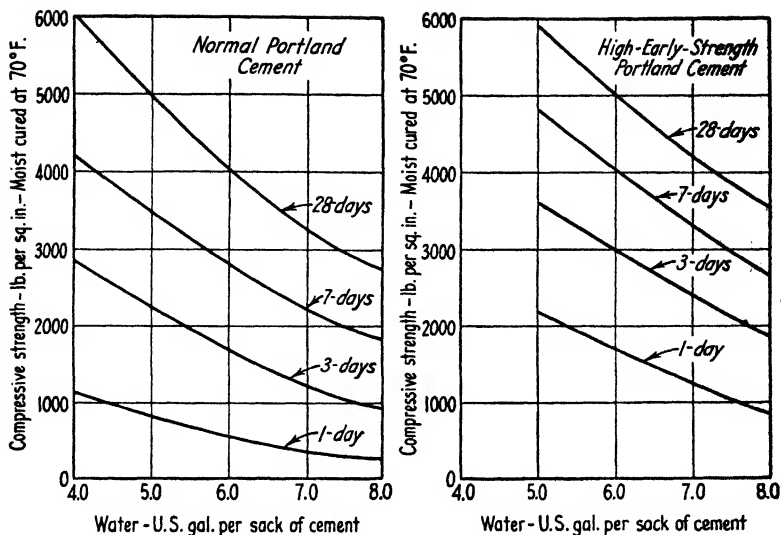

FIG. 20. Age-strength relation for normal and high-early-strength portland cements. The strengths indicated should be obtained on average construction projects where all materials, including the water, are controlled. On important work, tests should be made with the materials to be used on the project to establish job curves and fix design values.

#### APPROXIMATE QUANTITY OF SURFACE WATER CARRIED BY AVERAGE AGGREGATES \* †

Very wet sand	$\frac{3}{4}$ to 1 gal. per cu. ft.
Moderately wet sand	about $\frac{1}{2}$ gal. per cu. ft.
Moist sand	about $\frac{1}{4}$ gal. per cu. ft.
Moist gravel or crushed rock	about $\frac{1}{4}$ gal. per cu. ft.

#### APPROXIMATE ABSORPTION OF AGGREGATES \*

Average sand	1.0 per cent by weight
Pebbles and crushed limestone	1.0 per cent by weight
Trap rock and granite	0.5 per cent by weight
Porous sandstone	7.0 per cent by weight
Very light and porous aggregate may be as high as	25 per cent by weight

\* From Portland Cement Association.

† The coarser the aggregate, the less free water it will carry.

## MISCELLANEOUS DATA

TABLE 13. % OF 70° MOIST-CURED COMPRESSIVE STRENGTH  
NORMAL PORTLAND CEMENT

Placed and Cured at	4½ Gal. per Sack				6 Gal. per Sack				9 Gal. per Sack			
	1 d.	3 d.	7 d.	28 d.	1 d.	3 d.	7 d.	28 d.	1 d.	3 d.	7 d.	28 d.
60° F.	68%	78%	82%	83%	65%	74%	79%	82%	61%	71%	78%	78%
50° F.	28%	50%	60%	61%	22%	43%	52%	59%	14%	36%	51%	51%

% OF 70° MOIST-CURED COMPRESSIVE STRENGTH *EARLY-*  
*STRENGTH* PORTLAND CEMENT

60° F.	72%	88%	94%	94%	70%	78%	88%	93%	70%	85%	88%	94%
50° F.	38%	72%	80%	88%	34%	64%	75%	84%	32%	66%	73%	85%

Based on "Temperature Effects on Compressive Strengths of Concrete," Timms and Withey, A. C. I. Journal, Vol. VI, No. 2.

## CONCRETE BATCHING COMPUTATIONS

## Translating Design Mix into Batch Weights, Example

Given by laboratory:

Design mix by proportional weights (saturated surface dry aggregates):

	PARTS BY WEIGHT
Cement	1
Sand	1.84
Stone (fine)	2.00
Stone (coarse)	1.80
Water ( <i>W/C</i> ratio by weight) (4.8 gal. per sack)	0.426
Mix parts, total	7.066
Apparent (absolute) specific gravity of sand (without voids) saturated surface dry	2.63
Apparent (absolute) specific gravity of stone (without voids) saturated surface dry	2.63
Apparent (absolute) specific gravity of cement (without voids) saturated surface dry	3.10
Required slump	2 in. to 2½ in.
Determined by field test:	
Surface moisture in sand by weight	4%
Surface moisture in stone by weight	1%

## Constants:

Weight of cement per sack	94 lb.
Loose volume of cement per sack	1 cu. ft.
Weight of water per gallon	8.345 lb.
Volume of water per gallon	7.5 cu. ft.
Weight of water per cubic foot	62.5 lb.

## Computation of weight of each material required per sack of cement:

	POUNDS
Cement	$1 \times 94 = 94.00$
Sand	$1.84 \times 94 = 172.96$
Fine stone	$2.00 \times 94 = 188.00$
Coarse stone	$1.80 \times 94 = 169.20$
Water	$4.8 \times 8.345$ or $.426 \times 94 = 40.00$
Total weight of materials per sack of cement	$= 664.16$

## Computation of yield of concrete per sack of cement:

		SOLID VOLUME, CU. FT.
Cement	$\frac{94.00}{3.10 \times 62.5} =$	0.49
Sand	$\frac{172.96}{2.63 \times 62.5} =$	1.05
Fine stone	$\frac{188.00}{2.63 \times 62.5} =$	1.14
Coarse stone	$\frac{169.20}{2.63 \times 62.5} =$	1.03
Water	$\frac{40.00}{1 \times 62.5} =$	0.64
Theoretical yield of concrete per sack of cement	$=$	<u>4.35</u>
Theoretical unit weight of concrete per cubic foot	$= \frac{664.16}{4.35} =$	152.7 lb.
Theoretical cement content per cubic yard or cement factor	$= \frac{27}{4.35} =$	6.2 sacks

Assuming that sacked cement is being used, batch weights are computed to utilize an even number of sacks as illustrated for a 6-sack batch. *Note.* Volume of concrete is usually not allowed to exceed 10% of rated capacity of mixer, and so a 6-sack batch in this case is selected for a 27-E paving mixer as theoretical yield for 6-sack cement =  $4.35 \times 6 = 26.1$  cu. ft. of concrete. See Table 14 for batch weights.

TABLE 14. COMPUTATION OF BATCH WEIGHTS FOR A 6-SACK BATCH

MATERIAL	PARTS BY WEIGHT SPECIFIED	PERCENTAGE OF EACH AGGREGATE TO TOTAL AGGREGATE	BATCH WEIGHTS SURFACE DRY AGGREGATES 6-BAG BATCH, LB.		SURFACE MOISTURE BY TEST		BATCH WEIGHTS INCLUDING SURFACE MOISTURE 6-BAG BATCH, LB.
			%	Lb.	%	Lb.	
Cement	1		$94 \times 6 = 564$				564
Sand	1.84	32.6	$564 \times 1.84 = 1038$	4	$0.04 \times 1038 = 42$		$1038 + 42 = 1080$
Stone, fine	2.00	35.5	$564 \times 2.00 = 1128$	1	$0.01 \times 1128 = 11$		$1128 + 11 = 1139$
Stone, coarse	1.80	31.9	$564 \times 1.80 = 1015$	1	$0.01 \times 1015 = 10$		$1015 + 10 = 1025$
Water	0.426		$564 \times 0.426 = 240$		Total = 63		$240 - 63 = 177$
Total batch weights							<u>3985</u>

$177 \div 8.345 = 21.2$  gal. of water to be added at mixer

Resulting batch weights in last column should be posted at scales.

Adjust to required slump if necessary, but do not increase water/cement ratio.

**Check of Cement Factor during Operations, Example.***Given:*

Total weight of materials per sack of cement = 664.16 lb.

Actual weight of 1 cu. ft. of concrete by

unit weight test of freshly mixed sample = 152.5 lb.

*Computations:*Weight of 1-sack batch  $\frac{664.16}{152.5} = 4.35$  cu. ft. yield per sack.

Unit weight of concrete 152.5

Actual cement factor =  $27 \div 4.35 = 6.2$  sacks per cu. yd.

As the yield and cement factor check theoretically, no adjustment is necessary. (The air content of freshly mixed concrete made with normal portland cement is usually 0.5 to 1.0% and does not usually affect cement factor or yield enough to warrant adjustment.)

This check with normal portland-cement concrete is made to determine actual yield and cement factor when the cement factor may be running off as determined by the daily check of sacks used.

Actual sacks of cement used each day should be checked against theoretical quantity as follows: The volume of concrete is computed by dimensions. Required quantity of cement in sacks = theoretical cement factor  $\times$  cubic yards of concrete. **EXAMPLE.** *Given:* 1000 cu. yd. of concrete and cement factor = 6.2; cement used should be 6200 sacks. Overrun of 1½% usually allowed. Underrun usually due to one or more of the following:

1. Concrete laid deficient in width and depth; check and correct.
2. Excess of water or aggregate; check and correct.
3. Errors in batching or proportioning; check and correct.
4. Volume of concrete increased by voids; check and correct.

*Air-Entraining Cement*

When air-entraining portland cement is used, the volume of concrete is increased by the void content resulting from entrainment of air in the mix. The total yield must be determined in order to check with specification requirements.

It is desirable, and usually required, that the amount of entrained air shall be not less than 3% nor more than 6% by volume. For example, a normal portland cement mix producing a yield of 27.0 cu. ft. and requiring 6.2 bags of cement would, if air-entraining portland cement is substituted without further changes, increase the yield to approximately 28.1 cu. ft. if 4% air is entrained, in which case the cement factor would be reduced to 5.95 bags per cu. yd.

Specifications generally require that the same cement factor (yield of concrete) be maintained as for normal cement use. It is therefore necessary that other ingredients, usually sand and water, be reduced by such



amount that the same yield is secured. Other reasons for such adjustment are to maintain proper consistency, workability and freedom from excess mortar not required.

The amount of air-entrainment may be determined by comparing the actual weight of the fresh concrete with its air-free weight. Then the percentage of air (gravimetric method) is:

$$\left( \frac{\text{Diff. in wt.}}{\text{Air-free wt.}} \right) 100 = \% \text{ air}$$

If, in the above case, the actual unit weight in field is 144.0 and the air-free weight is 150.0 lb., then the percentage of air by above formula is:

$$\frac{(150 - 144)}{150} 100 = 4\%$$

In order to maintain correct yield the total batch weight for use with air-entraining portland cement is adjusted for trial purposes as follows:

Reduce sand by an amount equal to 3% of the total weight of all aggregates.

Reduce water by  $\frac{1}{4}$  gal. per bag of cement.

Measure unit weight of fresh concrete and divide into total batch weight for determining yield, air-entrainment, and cement factor.

The air-entrainment should be within the range of 3 to 6% in order to secure best results. Make any further adjustment necessary in water and sand and also in coarse aggregate, if desirable, to keep entrained air within this range and maintain desired cement factor.

Use following computation (from batch given above):

		ABSOLUTE VOLUME, CU. FT.
Cement	$\frac{94}{3.10 \times 62.5} =$	0.49
Sand	$\frac{172.96 - .03(530.16)}{2.63 \times 62.5} =$	0.957
Fine stone	$\frac{188}{2.63 \times 62.5} =$	1.14
Coarse stone	$\frac{169.2}{2.63 \times 62.5} =$	1.03
Water	$\frac{40 - 2.09}{62.5} =$	0.606
Air (if adjustments in aggregate and water are correct)	-	0.127
Yield	-	4.35

Batch weight, 1 sack  $\frac{646.17}{148.6^*} = 4.35$  cu. ft. yield per bag of cement.  
 Unit weight by test  $\frac{646.17}{148.6^*} = 4.35$  cu. ft. yield per bag of cement.  
 Cement factor =  $27 \div 4.35 = 6.2$  bags per cu. yd.  
 Sand-aggregate ratio  $100(0.957) \div (3.127) = 30.6\%$ .

CONCRETE REINFORCEMENT

TABLE 15. STANDARD STYLES OF AMERICAN ELECTRICALLY WELDED MESH

SPACING OF WIRES IN INCHES		AMERICAN STEEL & WIRE CO. GAGE NO.		SECT. AREA PER FOOT OF FABRIC (Sq. IN.)	
<i>Long.</i>	<i>Trans.</i>	<i>Long.</i>	<i>Trans.</i>	<i>Long.</i>	<i>Trans.</i>
2	16	1	7	0.377	0.018
2	16	2	8	.325	.015
2	16	3	8	.280	.015
2	16	4	9	.239	.013
3	16	2	8	.216	.016
2	16	5	10	.202	.011
3	16	3	8	.187	.015
2	16	6	10	.174	.011
3	16	4	9	.159	.013
2	16	7	11	.148	.009
4	16	3	8	.140	.015
3	16	5	10	.135	.011
4	16	4	9	.120	.013
3	16	6	10	.116	.011
4	16	5	10	.101	.011
3	16	7	11	.098	.009
4	16	6	10	.087	.011
3	16	8	12	.082	.007
4	16	7	11	.074	.009
4	12	8	12	.062	.009
4	12	9	12	.052	.009
4	12	10	12	.043	.009
4	12	12	12	.026	.009
6	6	7	7	.049	.049
4	4	4	4	.120	.120
4	4	6	6	.087	.087

See pp. 58 and 59 for gage data.

\* This is an assumed unit weight for purpose of this example. Actually, the unit weight may be higher or lower than this, in which event further adjustments of water or sand or also coarse aggregate must be made in order to maintain the desired cement factor and at the same time secure the necessary weight loss to insure proper air-entrainment.

**TABLE 16. PROPERTIES OF REINFORCING BARS AND HOOK DIMENSIONS**

Method of hooking bars as recommended by A.C.I.

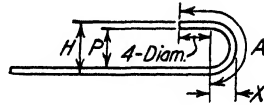

SIZE	AREA	PERIMETER	WT. PER LIN. FT.	P	H	X	A
1/4" φ	0.05	0.79	0.167	1 1/4"	1 3/4"	7/8"	3 3/8"
3/8" φ	0.11	1.18	0.376	1 7/8"	2 5/8"	1 3/8"	5"
1/2" φ	0.20	1.57	0.668	2 1/2"	3 1/2"	1 3/4"	6 3/4"
1/2" □	0.25	2.00	0.850	2 1/2"	3 1/2"	1 3/4"	6 3/4"
5/8" φ	0.31	1.96	1.043	3 1/8"	4 3/8"	2 1/8"	8 3/8"
3/4" φ	0.44	2.36	1.502	3 3/4"	5 1/4"	2 5/8"	10"
7/8" φ	0.60	2.75	2.044	4 3/8"	6 1/8"	3"	11 3/4"
1" φ	0.79	3.14	2.670	5"	7"	3 1/2"	1' 1 3/8"
1" □	1.00	4.00	3.400	5"	7"	3 1/2"	1' 1 3/8"
1 1/8" □	1.27	4.50	4.303	5 5/8"	7 7/8"	3 7/8"	1' 3 1/8"
1 1/4" □	1.56	5.00	5.313	6 1/4"	8 3/4"	4 3/8"	1' 4 3/4"

**TABLE 17. MINIMUM BEAM WIDTHS IN INCHES \***



SIZE OF BAR	NO. OF BARS IN SINGLE LAYER OF REINFORCEMENT							ADD FOR EACH ADDI- TIONAL BAR
	2	3	4	5	6	7	8	
1/2" φ	6"	7 1/2"	9"					1 1/2"
1/2" □	6 1/2"	8"	10"					1 3/4"
5/8" φ	6"	8"	9 1/2"	11"	12 1/2"			1 5/8"
3/4" φ	6 1/2"	8 1/2"	10 1/2"	12"	14"			1 7/8"
7/8" φ	7"	9"	11 1/2"	13 1/2"	16"	18"	20"	2 3/16"
1" φ	7 1/2"	10"	12 1/2"	15"	17 1/2"	20"	22 1/2"	2 1/2"
1" □	8"	11"	14"	17"	20"	23"	26"	3"
1 1/8" □	8 1/2"	12"	15"	18 1/2"	22"	25 1/2"	28 1/2"	3 3/8"
1 1/4" □	9"	12 1/2"	16 1/2"	20"	24"	27"	31 1/2"	3 3/4"

\* Where specially anchored bars are used, haunch width may be narrowed.

TABLE 18. AREA OF STEEL PER FOOT OF WIDTH

BAR SIZE	SPACING OF BARS																
	4"	4½"	5"	5½"	6"	6½"	7"	7½"	8"	8½"	9"	9½"	10"	10½"	11"	11½"	12"
¼"φ	0.15	0.13	0.12	0.11	0.10	0.09	0.08	0.08	0.07	0.07	0.07	0.06	0.06	0.06	0.05	0.05	0.05
⅜"φ	0.33	0.29	0.26	0.24	0.22	0.20	0.19	0.18	0.17	0.16	0.15	0.14	0.13	0.13	0.12	0.11	0.11
½"φ	0.59	0.52	0.47	0.43	0.39	0.36	0.34	0.31	0.29	0.28	0.26	0.25	0.23	0.22	0.21	0.20	0.20
½"□	0.75	0.67	0.60	0.55	0.50	0.46	0.43	0.40	0.37	0.35	0.33	0.32	0.30	0.29	0.27	0.26	0.25
⅝"φ	0.92	0.82	0.74	0.67	0.61	0.57	0.53	0.49	0.46	0.43	0.41	0.39	0.37	0.35	0.33	0.32	0.31
¾"φ	1.33	1.18	1.06	0.96	0.88	0.82	0.76	0.71	0.66	0.62	0.59	0.56	0.53	0.51	0.48	0.46	0.44
⅞"φ	1.80	1.60	1.44	1.31	1.20	1.11	1.03	0.96	0.90	0.85	0.80	0.76	0.72	0.69	0.66	0.62	0.60
1"φ	2.36	2.09	1.88	1.71	1.57	1.45	1.35	1.26	1.18	1.11	1.05	0.99	0.94	0.90	0.86	0.82	0.78
1"□	3.00	2.67	2.40	2.18	2.00	1.85	1.71	1.60	1.50	1.41	1.33	1.26	1.20	1.14	1.09	1.04	1.00
1½"□	3.80	3.37	3.04	2.76	2.53	2.34	2.17	2.02	1.90	1.79	1.69	1.60	1.52	1.45	1.38	1.32	1.27
1¾"□	4.69	4.17	3.75	3.41	3.13	2.89	2.68	2.50	2.34	2.21	2.08	1.97	1.87	1.79	1.70	1.63	1.56

## LOAD TESTS

*Permanent measurable deflections are a sign of weakness.*

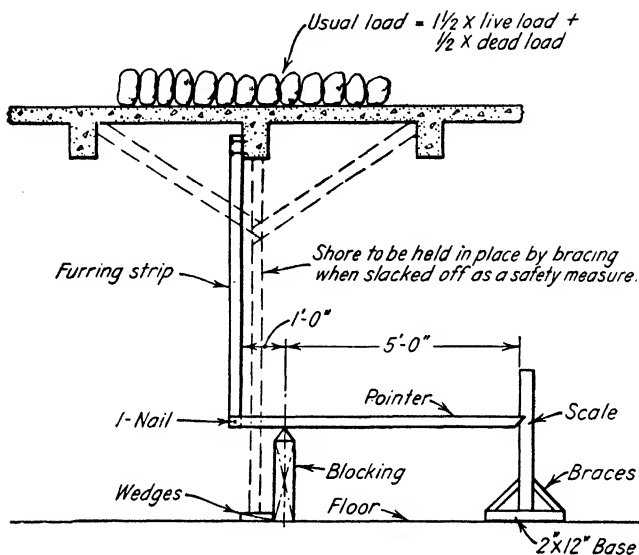

FIG. 21. Standard deflection magnifier for load tests.

*Note.* When the expense of safety shoring is too great, men conducting a load test may be protected by using a roller as a test load, the roller being towed from some safe distance. Level shots to measure deflection can be taken.

---

 Engineer

## REPORT ON CONCRETE STRUCTURES

FIELD INSPECTION

*(Short Form)*

---

 Report No. \_\_\_\_\_ Date \_\_\_\_\_

Job \_\_\_\_\_ Temp. \_\_\_\_\_

 Reported to \_\_\_\_\_
 

---

## WORK INSPECTED

	Location or Station	Reinforcement and Forms	Concrete
Footings			
Columns			
Beams			
Slabs			
Walls			

Aggregate inspected \_\_\_\_\_

Slump tests made \_\_\_\_\_

Test cylinders made \_\_\_\_\_

Frost protection checked \_\_\_\_\_

---

 Inspector

## CONCRETE

---

 Engineer

 REPORT ON CONCRETE STRUCTURES  
 FIELD INSPECTION  
 (Long Form)

Report No. \_\_\_\_\_ Date \_\_\_\_\_

Job \_\_\_\_\_ Temp. \_\_\_\_\_

Reported to \_\_\_\_\_

---

 WORK INSPECTED

	Location or Station	Reinforcement and Forms	Concrete	Yardage	
				Today	Total to date incl.
Footings					
Columns					
Beams					
Slabs					
Walls					

Cement: tested and sealed \_\_\_\_\_

Coarse aggregate: size, appearance, cleanliness, soundness \_\_\_\_\_

Fine aggregate: grading, silt content by bottle sediment test \_\_\_\_\_

Forms: dimensions, oil, cleanliness, tightness \_\_\_\_\_

Reinforcement: inserts, recesses, concrete coverage for protection \_\_\_\_\_

Slump tests: cylinders and/or test beams \_\_\_\_\_

Construction joints \_\_\_\_\_

Mixing: proportioning, water content, time of mixing \_\_\_\_\_

Concrete placing, vibration or rodding \_\_\_\_\_

Finishing \_\_\_\_\_

Protection vs. frost \_\_\_\_\_

Curing \_\_\_\_\_

Form stripping and reshoring \_\_\_\_\_

---

 Inspector

Engineer

REPORT ON CONCRETE TEST SPECIMENS \*

FIELD DATA					
<i>To be filled in by maker of specimens</i>					
Project, name and symbol:				District:	
No. specimens in shipment:		Type of specimens: <input type="checkbox"/> Cylinders: <input type="checkbox"/> Cores: <input type="checkbox"/> Beams: <input type="checkbox"/> Diameter, in.		Symbols:	
Date placed:	Date extracted (cores):	Date shipped:		Monolith extracted from:	
Cubic yards represented:	Mixture (by weight):	Slump, in.:	Sand. Total aggregate ratio % by vol.		
Theoretical unit wt.:	Actual Unit Weight:	Calculated air content:	Net actual W/C:		
lb./cu. ft.	lb./cu. ft.	%	gal./bag		
Admixture type and amount:		<i>Cement Factor</i>			
%		Theoretical:	Actual:		
		bags/cu. yd.	bags/cu. yd.		
<i>Cement</i>					
Cement Spec. SS-C-		Type:	Brand:		
Mill name and location:			Car number:		
<i>Type and Source of Aggregate</i>					
Fine aggregate:			Coarse aggregate:		
<i>By Whom Prepared (Inspector)</i>					
LABORATORY DATA					
<i>To be filled in by laboratory</i>					
Specimen No.	Date Tested:	<input type="checkbox"/> Flexural Strength, p.s.i.			
		<input type="checkbox"/> Compressive Strength, p.s.i.			
		7-Day	14-Day	28-Day	90-Day
Date specimens received:			Temperature of specimens when received:		
			°F.		
Remarks:					

\* From War Department Corps of Engineers, North Atlantic Division.



---

Engineer

REPORT ON CONCRETE TEST BEAMS

No.	Date Cast	Loca- tion	Date Shipped	Flexural Strength		Remarks		
				7-day	28-day	Slump	Den- sity	Percentage of Air Voids

---

Inspector

\_\_\_\_\_  
Engineer

REPORT ON CEMENT ANALYSES \*

Date \_\_\_\_\_

Client \_\_\_\_\_ Report \_\_\_\_\_

Project \_\_\_\_\_

Mill \_\_\_\_\_

Specific Surface	Time of Set		Soundness	Tensile Strength 1-3				Ignition Loss	Insoluble Residue	Magnesia	Sulfuric Anhydride
	Initial	Final		1	3	7	28				

Reported to:

The above tests <sup>do</sup> fulfill A.S.T.M. Spec. \_\_\_\_\_ Type \_\_\_\_\_  
<sub>do not</sub>

\_\_\_\_\_  
Inspector

\* Adapted from Haller Engineering Associates, Inc.

---

 Engineer

 CEMENT SHIPPING REPORT \*
 

---

Gentlemen:

Shipments of portland cement indicated have been mill inspected and sealed for your account.

Car Number	Seal	Contents Bbl.	Bin	Brand	Destination

Reported to:

---

 Inspector

\* Adapted from Haller Engineering Associates, Inc.

# MASONRY

## CHECK LIST FOR INSPECTORS

### MASONRY

#### Inspectors' Equipment

Complete set of plans, specifications, approved samples and shop drawings.

Set of sieves of specified sand sizes.

Plumb bob and line.

6-foot rule.

#### Procedure in Inspection

Prepare and ship samples of brick, concrete block, clay tile, sand lime bricks, cement, and sand lime to laboratory for test.

Perform sieve tests on sand for mortar at site.

Inspect brick. Discard underburned brick (sometimes called salmon brick), which is pale in color if a red brick. Compare brick with specifications. Face brick can best be checked from approved sample.

See that joints are according to specification.

If the engineer has built up a sample of wall, see that this is followed.

Check thickness of joints, type of pointing, and mortar against specifications.

Check lime against lime memorandum on pp. 49 and 50, particularly as to length of time after slaking.

Do not permit laying of brick in weather cold enough to freeze mortar. See specifications.

Check bonding of brickwork.

In warm weather, dry brick to be wetted.

All beds and vertical joints to be full without voids.

No voids permitted in interior of wall.

Check wall for plumbness and level courses.

All flashings, weep holes, and sills built in as required by plans and specifications.

Lift brick up that are laid. There should be sufficient suction to lift mortar with them.

### LIME FOR MORTAR AND MASONRY

Lime is produced in two forms as follows:

1. High-calcium quicklime, which is sent to the job in powdered form of two different kinds: pulverized or granular, labeled as quicklime. One has no particular advantage over the other.

This lime is slaked by adding water similar to the method of preparing lump lime, and must be allowed to age 3 to 7 days.

One ton of quicklime will produce approximately 80 cu. ft. of stiff lime putty.

2. Hydrated lime, which is lime containing water in chemical combination. It is a calcium hydroxide and comes on the job labeled hydrated masons' lime. This lime also comes in two different kinds: (a) Ordinary hydrated lime. This product should be soaked in water for not less than 24 hours before using. (b) Pressure hydrated lime. This lime can safely be put in the mixer without any treatment whatever. It is used exactly the same as cement.

### IDENTIFICATION OF BUILDING STONE

Granite is a coarse-grained, hard, igneous rock in which the different minerals give a speckled appearance.

True granite contains the following elements:

Quartz—a clear, hard crystal.

Feldspar, which looks like a yellowish tooth.

Hornblende—hard, black, shiny.

Mica—thin, flaky, transparent.

Pyrite, which looks like a yellowish metal.

Bastard granite contains some but not all of these crystals.

Both granites are excellent building materials although too much pyrite might cause stain and a possible breaking down of the stone by weathering.

Gneiss may be either sedimentary or igneous rock which has been metamorphosed, that is, compressed and worked under sufficient pressure and heat so that the structural changes were by plastic flow rather than by cracking.

In gneiss, the interlocking minerals are for the most part visible to the naked eye. The gneisses are banded. Gneiss is a satisfactory building material.

Gneisses merge into schists as the texture becomes finer.

Schists with a large percentage of mica are known as mica schists. As a building material they are subject to cleavage.

Trap rock is heavy, dark, and igneous. The origin of its name is steps as it tends to break into steplike blocks. Trap rock is an excellent building material.

Basalt is a dark igneous rock ranging from dark gray to black. Its texture is very fine. Basalt is an excellent building material.

Marble is a metamorphosed limestone and in its broken state shows shiny, smooth, crystalline surfaces. It is vulnerable to dissolving in certain atmospheres or water. Its hardness is medium. Marble may be made from either calcitic or dolomitic limestone. The dolomitic limestone does not effervesce with dilute acid. Marble has excellent durability and workability for buildings.

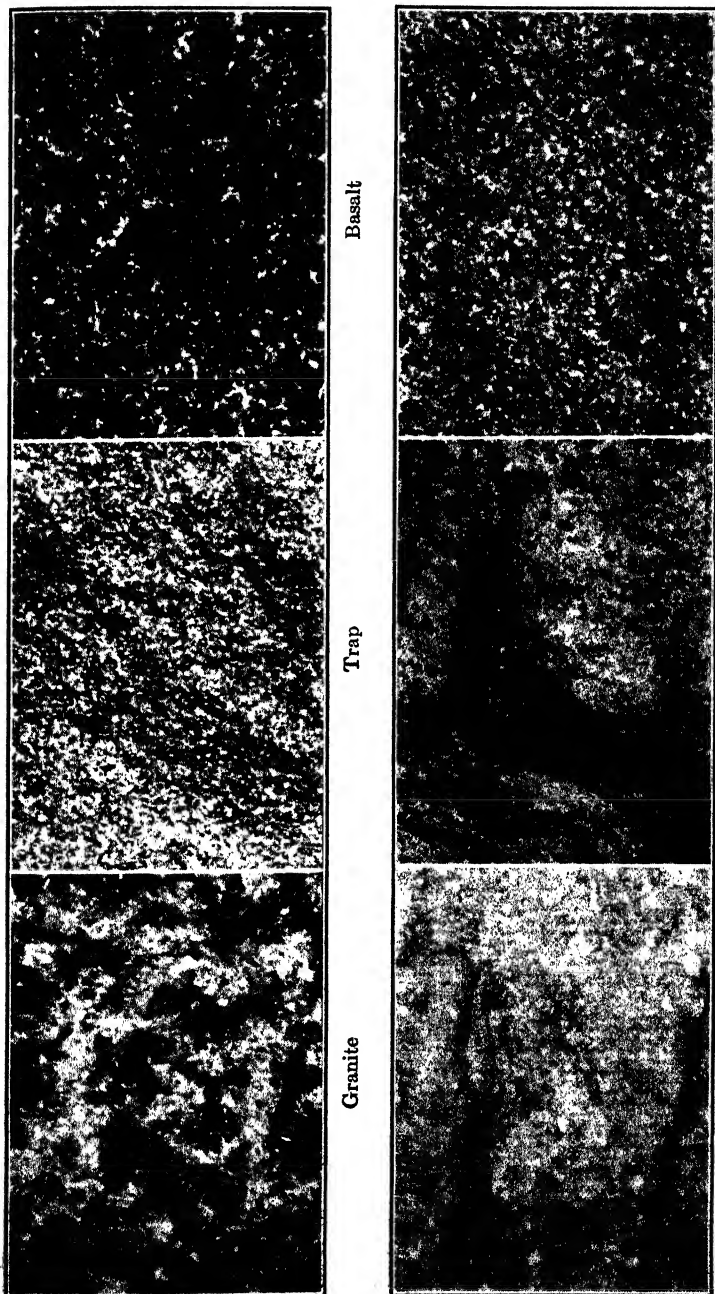

Basalt

Trap

Granite

Sandstone

Limestone  
FIG. 21A.

White Marble



Schist

Gneiss

FIG. 21B.

Limestone is calcium carbonate rock of sedimentary origin. It is somewhat vulnerable and may be distinguished from magnesium carbonate limestone by the fact that it effervesces under a dilute solution of acid, which is not the case with the dolomite. Individual grains cannot be distinguished. Limestone is soft, easily worked, and a reasonably good building stone but vulnerable.

Sandstone, as its name implies, is made up of sand cemented with silica or lime. In general, the grains are distinguishable. Its reliability as a building material can be ascertained only after investigation; for instance, brownstone is a sandstone which has not always proved reliable.

Slates are metamorphosed shale and have cleavage planes along which the stone is split for commercial purposes. These cleavage planes occur at an angle to the bed planes. Slates are a satisfactory building material, particularly for roofs.

Shale comes from silt and clay and occurs in beds which tend to "shale" off. It is softer than limestone and unreliable as a building material.

Caution: Sedimentary stone should be laid on natural beds.

Definition: Porphyritic texture means a texture in which the larger minerals appear to be embedded in a matrix.

# STRUCTURAL STEEL

## CHECK LIST FOR INSPECTORS

### STRUCTURAL STEEL

*The following is based on the assumption that steel has been inspected in shop. If this has not been done, steel should be completely checked against shop details and for correct sections.*

#### Inspectors' Equipment

Complete set of erection plans and specifications.

Details should not be necessary unless shop inspection was not made or unless necessary to show special field connections.

Steel tape.

6-ft. rule.

Plumb bob.

Rivet-testing hammer.

Steel handbook.

Necessary coveralls, helmet, gloves, etc.

Calipers, gages, etc.

#### Procedure in Inspection

Members should be checked for damage in shipment, such as bent plates, connection angles or members themselves, and condition of paint. This checking should be done before erection so that damaged pieces may be rejected or rectified by straightening or reinforcing.

Anchor bolts should be checked as to size, location, elevation, and plumbing.

Base plates and grillages should be checked for correct work, level, and proper grouting. In general, they should be leveled up so as to carry load direct to foundations or walls.

Columns resting on base plates, grillages, or girders and column splices should be checked for proper bearing of milled surfaces. Where column sections change in nominal section and milled fillers are used, they should be carefully inspected.

Minor corrections may be made with steel shims.

Plumbing of columns should be checked to specified tolerance before any riveting or permanent bolting of floors is done.

As erection proceeds, inspector should match pieces against erection plans to see that proper piece is in correct position. Usually material is properly marked, but where there is any doubt, section of member should be checked.

The inspector should make sure that rivets or turned bolts are used where called for on erection plans or specifications. If there is any question



as to what connection is to be used, inspector should check with engineer's office.

Rivets should be checked for size and tightness. The alignment of holes should be checked before driving. Where they are not true, holes should be reamed and larger rivets driven. If rivet is tight and has full head, it should be passed.

In no case should the following be allowed:

Burning of holes with torch.

Gouging of holes with drift pins.

Tightening of rivet by calking of head.

Rivets should be tested with small hammer. Strike rivet head with several good blows of hammer to see if it can be "floated" or moved up and down. Defective rivets should be marked with chalk. When a loose rivet is removed, it may loosen adjoining rivets. In small groups, it may be necessary to remove all the rivets in group. However, as a rivet shrinks in cooling, a slight vibration is not cause for condemning a rivet. Sufficient temporary bolts should be used to hold pieces tight together while riveting.

Bolted connections should be reasonably tight but should not be turned up so as to strip thread. Where washer, lock washer, lock nuts, etc., are called for, they should be checked.

Beams on walls should be checked for proper wall bearing and anchorage.

Inspector should cooperate with the erector in safeguarding structure from accidents during erection. He should see that derrick base is secured from horizontal thrust of boom in any direction. Steel carrying derricks should be strong enough and have sufficient connections for erection stresses involved. The erectors should be warned against such dangerous practices as lifting too heavy a load for the strength of counter ties of derrick, booming out too far and splicing of boom. Guying and bracing of steel in process of erection against wind pressure are important. Shrinkage of a wet rope should be allowed for.

Painting should be done according to specifications. Where shop paint has been removed during shipment, repainting should be done before erection. Field paint should be of different color from shop paint. All steel should be free from rust and scale and should be dry. Painting should not be permitted in freezing weather.

Inspector should be familiar with design of building if possible. In any event, he should confer with the engineer to see whether there are any special connections which should be watched. If, in the opinion of inspector, any part of the structure does not appear structurally sound, he should notify engineer.

TABLE 19. STRUCTURAL STEEL SECTIONS

Amer. Std. Channel Sect.

D	Wt	S	t	d	b	D	Wt	S	t	d	b	D	Wt	S	t	d	b	D	Wt	S	t	d	b
18	58	74.5	.70	18	4 1/4	12	30	26.9	.51	12	3 1/2	9	20	13.5	.45	9	2 3/4	6	13.0	5.8	.44	6	2 3/4
I	51.9	69.1	.60	18	4 1/4	I	25	23.9	.39	12	3	I	15	11.3	.28	9	2 3/4	I	10.5	5.0	.31	6	2
	42.7	61.0	.45	18	4		20.7	21.4	.28	12	3		13.4	10.5	.23	9	2 3/4		8.2	4.3	.20	6	1 1/2
15	50	53.6	.72	15	3 3/4	10	30	20.6	.67	10	3	8	18.75	10.9	.49	8	2 3/4	5	9.0	3.5	.32	5	1 3/4
I	40	46.2	.62	15	3 1/2	I	25	18.1	.53	10	2 3/4	I	13.75	9.0	.30	8	2 3/4	I	6.7	3.0	.19	5	1 3/4
	33.9	41.7	.40	15	3 3/4		20	15.7	.38	10	2 3/4		11.5	8.1	.22	8	2 3/4		7.25	2.3	.32	4	1 3/4
13	50	48.1	.79	13	4 3/4	I	15.3	13.4	.24	10	2 3/4	7	14.75	7.7	.42	7	2 3/4	4	5.4	1.9	.18	4	1 3/4
I	40	41.7	.56	13	4 1/4		20	15.7	.38	10	2 3/4	I	12.25	6.9	.31	7	2 3/4	I	6.0	1.4	.36	3	1 3/4
	35	38.6	.45	13	4 1/4		15.3	13.4	.24	10	2 3/4		9.8	6.0	.21	7	2 3/4		5.0	1.2	.26	3	1 1/4
	31.8	36.5	.38	13	4														4.1	1.1	.17	3	1 3/4

Amer. Std. Beam Sect.

D	Wt	S	t	d	b	D	Wt	S	t	d	b	D	Wt	S	t	d	b	D	Wt	S	t	d	b
24	120	250.9	.80	24	8	18	70	101.9	.71	18	6 1/4	10	35	29.2	.59	10	5	5	14.75	6.0	.49	5	3 1/4
I	105.9	234.3	.62	24	7 1/4	I	64.7	88.4	.46	18	6	I	25.4	24.4	.31	10	4 5/8	I	10.0	4.8	.21	5	3
	100	197.6	.75	24	7 1/4		50	64.2	.55	15	5 5/8	I	18.4	16.0	.44	8	4 1/8		9.5	3.3	.33	4	2 3/4
	79.9	185.8	.62	24	7 1/4	I	42.9	58.9	.41	15	5 1/2	8	23.0	14.2	.27	8	4	4	7.7	3.0	.19	4	2 3/4
	79.9	173.9	.50	24	7		15	50	58.9	.41	15	5 1/2	8	18.4	.27	8	4						
20	95	160.0	.85	20	7 1/4	7	50	50.3	.69	12	5 1/2	7	20.0	12.0	.45	7	3 3/4	4	9.5	3.3	.33	4	2 3/4
I	85	150.2	.65	20	7	I	40.8	44.8	.46	12	5 1/4	I	15.3	10.4	.25	7	3 3/8	I	7.7	3.0	.19	4	2 3/4
	75	136.3	.64	20	6 3/4		35	37.8	.43	12	5 1/4	6	17.25	8.7	.47	6	3 5/8	3	7.5	1.9	.35	3	2 1/4
	65.4	116.9	.50	20	6 1/4	I	31.8	36.0	.35	12	5	I	12.5	7.3	.23	6	3 3/8	I	5.7	1.7	.17	3	2 3/4

NOMENCLATURE

D = nominal depth in inches.  
 Wt = weight per foot in pounds.  
 S = Section modulus.  
 t = web thickness in inches.  
 d = actual depth in inches.  
 b = flange width in inches.

I = American Standard Section.



	649.9	77.30	4.15	114	220.1	59	18 3/4	11 3/4	138	216.0	.66	14 3/4	14 3/4	112	126.3	.75	11 1/4	10 3/4	
210	586.1	71.30	4.15	105	202.2	55	18 3/4	11 3/4	127	202.0	.61	14 3/4	14 3/4	100	112.4	.68	11 1/4	10 3/4	
190	528.2	65.20	4.15	96	184.4	51	18 1/2	11 1/2	119	189.4	.57	14 1/2	14 1/2	89	99.7	.61	10 3/4	10 1/4	
172	379.7	61.30	4.15	85	158.1	53	18 3/4	8 3/4	111	176.3	.54	14 3/4	14 3/4	77	86.1	.53	10 3/4	10 1/4	
30	354.6	58.30	4.15	77	141.7	47	18 1/2	8 3/4	103	163.6	.49	14 3/4	14 3/4	72	80.1	.51	10 1/2	10 1/4	
182	327.9	56.30	4.15	70	128.2	44	18	8 3/4	WF	150.6	.46	14 3/4	14 3/4	WF	66	73.7	.46	10 3/4	10 3/4
116	299.2	54.20	4.15	64	117.0	40	17 3/4	8 3/4	95	150.6	.46	14 3/4	14 3/4	60	67.1	.41	10 1/4	10 3/4	
108	277.9	52.30	4.15	60	107.8	42	18 1/4	7 3/4	87	138.1	.42	14 1/4	14 1/4	54	60.4	.37	10 1/4	10 3/4	
				55	98.2	39	18 1/4	7 3/4						49	54.6	.34	10	10	
				50	89.0	36	18	7 3/4											
									84	130.9	.45	14 3/4	12						
									78	121.1	.43	14	12	45	49.1	.35	10 3/4	8	
									74	112.3	.45	14 1/4	10 3/4	39	42.2	.32	10	8	
									68	103.0	.42	14	10	33	35.0	.29	9 3/4	8	
									61	92.2	.38	13 3/4	10	29	30.8	.29	10 1/4	5 3/4	
									53	77.8	.37	14	8	10	26.4	.25	10 3/4	5 3/4	
									48	70.2	.34	13 3/4	8	WF	21	21.5	.24	9 3/4	5 3/4
27	402.8	73.27	4.14	71	115.9	49	16 1/2	8 3/4	43	62.7	.31	13 3/4	8	19	18.8	.25	10 1/4	4	
160	444.5	66.27	4.14	64	104.2	44	16	8 3/4	38	54.6	.31	14 1/4	6 3/4	17	16.2	.24	10 1/4	4	
177	402.9	60.20	4.14	58	94.1	41	15 3/4	8 3/4	34	48.5	.29	14	6 3/4	15	13.8	.23	10	4	
18	289.2	57.27	4.10	50	80.7	38	16 1/4	7 3/4	30	41.8	.27	13 3/4	6 3/4	11.5	10.5	.18	9 3/4	4	
102	266.3	52.27	4.10	45	72.4	35	16 1/4	7 3/4											
94	242.8	49.26	4.10	40	64.4	31	16	7 3/4											
				36	56.3	30	15 3/4	7 3/4											

3-12  
1-4-7  
2-13

PROPERTIES OF ANGLES

NOMENCLATURE			PROPERTIES OF ANGLES															
	Size	S 1-1	Area	r 1-1	r 3-3	Size	S 1-1	S 2-2	Area	r 1-1	r 2-2	r 3-3	D					
													Wt	Wf	S			
	2 1/2 x 2 1/2 x 1/4	.39	1.19	.77	.49	2 1/2 x 2 x 1/4	.38	.25	1.06									
	3 x 3 x 1/4	.58	1.44	.93	.59	3 x 2 1/2 x 1/4	.56	.40	1.31	.78	.59							
	3 x 3 x 5/16	.71	1.78	.92	.59	3 1/2 x 3 x 1/4	.78	.59	1.56	1.11	.91							
	3 1/2 x 3 1/2 x 1/4	.98	2.09	1.00	.69	4 x 3 x 1/4	1.0	.73	2.09	1.28	.90							
	3 1/2 x 3 1/2 x 5/16	1.13	2.40	1.08	.69	4 x 3 x 5/16	1.2	1.0	2.56	1.27	.89							
	4 x 4 x 1/4	1.3	2.40	1.24	.80	5 x 3 1/2 x 3/16	1.9	1.2	3.05	1.61	1.02							
	4 x 4 x 5/16	2.4	3.61	1.56	.80	5 x 3 1/2 x 1/4	2.3	1.4	3.53	1.59	1.01							
	5 x 5 x 1/4	3.3	4.36	1.88	.99	6 x 4 x 3/16	3.3	1.6	4.18	1.92	1.16							
	5 x 5 x 5/16	4.1	5.06	1.87	.99	6 x 4 x 1/4	3.8	1.9	4.75	1.91	1.15							
	6 x 6 x 1/4	4.0	5.75	1.86	1.18	6 x 4 x 1/2	4.3	2.1										
	6 x 6 x 5/16	4.6																

D = nominal depth in inches.  
 Wf = weight per foot in pounds.  
 S = section modulus.  
 t = web thickness in inches.  
 d = actual depth in inches.  
 b = flange width in inches.  
 B = Bethlehem Steel Co. Section.  
 C = U. S. Steel Corp. Section.

TABLE 20. WIRE AND SHEET METAL GAGES IN DECIMALS OF AN INCH \*

Name of Gage	United States Standard Gage †		American Steel & Wire Co., ‡ and John A. Roebling Sons Co.	American or Brown & Sharpe Wire Gage	New Birmingham Standard Sheet and Hoop Gage	British Imperial or English Legal Standard Wire Gage	Birmingham or Stubs Iron Wire Gage	Name of Gage
Principal Use	Uncoated steel sheets and light plates		Steel wire except music wire	Non-ferrous sheets and wire	Iron and steel sheets and hoops	Wire	Strips, bands, hoops, and wire	Principal Use
Gage No.	Weight, lb. per sq. ft.	Approx. Thickness, inches	Thickness, inches					Gage No.
			7/0's	20.00	0.4902	0.4900		
6/0's	18.75	.4596	.4615	0.5800	.625	.464		6/0's
5/0's	17.50	.4289	.4305	.5165	.5883	.432	0.500	5/0's
4/0's	16.25	.3983	.3938	.4600	.5416	.400	.454	4/0's
3/0's	15.00	.3676	.3625	.4096	.500	.372	.425	3/0's
2/0's	13.75	.3370	.3310	.3648	.4452	.348	.380	2/0's
0	12.50	.3064	.3065	.3249	.3964	.324	.340	0
1	11.25	.2757	.2830	.2893	.3532	.300	.300	1
2	10.625	.2604	.2625	.2576	.3147	.276	.284	2
3	10.00	.2451	.2437	.2294	.2804	.252	.259	3
4	9.375	.2298	.2253	.2043	.250	.232	.238	4
5	8.75	.2145	.2070	.1819	.2225	.212	.220	5
6	8.125	.1991	.1920	.1620	.1981	.192	.203	6
7	7.50	.1838	.1770	.1443	.1764	.176	.180	7
8	6.875	.1685	.1620	.1285	.1570	.160	.165	8
9	6.25	.1532	.1483	.1144	.1398	.144	.148	9
10	5.625	.1379	.1350	.1019	.1250	.128	.134	10
11	5.00	.1225	.1205	.0907	.1113	.116	.120	11
12	4.375	.1072	.1055	.0808	.0991	.104	.106	12
13	3.75	.0919	.0915	.0720	.0882	.092	.095	13
14	3.125	.0766	.0800	.0641	.0785	.080	.083	14
15	2.8125	.0689	.0720	.0571	.0699	.072	.072	15
16	2.50	.0613	.0625	.0508	.0625	.064	.065	16
17	2.25	.0551	.0540	.0453	.0556	.056	.058	17
18	2.00	.0490	.0475	.0403	.0495	.048	.049	18
19	1.75	.0429	.0410	.0359	.0440	.040	.042	19
20	1.50	.0368	.0348	.0320	.0392	.036	.035	20

TABLE 20. WIRE AND SHEET METAL GAGES IN DECIMALS OF AN INCH (Continued) \*

Name of Gage	United States Standard Gage †		American Steel & Wire Co., ‡ and John A. Roebbling Sons Co.	American or Brown & Sharpe Wire Gage	New Birmingham Standard Sheet and Hoop Gage	British Imperial or English Legal Standard Wire Gage	Birmingham or Stubs Iron Wire Gage	Name of Gage
Principal Use	Uncoated steel sheets and light plates		Steel wire except music wire	Non-ferrous sheets and wire	Iron and steel sheets and hoops	Wire	Strips, bands, hoops, and wire	Principal Use
Gage No.	Weight, lb. per sq. ft.	Approx. Thickness, inches	Thickness, inches					Gage No.
21	1.375	.0337	.0318	.0285	.0349	.032	.032	21
22	1.25	.0306	.0286	.0253	.0313	.028	.028	22
23	1.125	.0276	.0258	.0226	.0278	.024	.025	23
24	1.00	.0245	.0230	.0201	.0248	.022	.022	24
25	.875	.0214	.0204	.0179	.0220	.020	.020	25
26	.75	.0184	.0181	.0159	.0196	.018	.018	26
27	.6875	.0169	.0173	.0142	.0175	.0164	.016	27
28	.625	.0153	.0162	.0126	.0156	.0148	.014	28
29	.5625	.0138	.0150	.0113	.0139	.0136	.013	29
30	.50	.0123	.0140	.0100	.0123	.0124	.012	30
31	.4375	.0107	.0132	.0089	.0110	.0116	.010	31
32	.4062	.0100	.0128	.0080	.0098	.0108	.009	32
33	.375	.0092	.0118	.0071	.0087	.0100	.008	33
34	.3438	.0084	.0104	.0063	.0077	.0092	.007	34
35	.3125	.0077	.0095	.0056	.0069	.0084	.005	35
36	.2812	.0069	.0090	.0050	.0061	.0076	.004	36
37	.2656	.0065	.0085	.0045	.0054	.0068		37
38	.25	.0061	.0080	.0040	.0048	.0060		38
39	.2344	.0057	.0075	.0035	.0043	.0052		39
40	.2188	.0054	.0070	.0031	.0039	.0048		40

\* From American Institute of Steel Construction.

† U.S. Standard Gage is officially a weight gage (in ounces per square foot) based on wrought iron at 480 lb. per cu. ft. The values tabulated above give the thickness of steel (at 489.6 lb. per cu. ft.) that will approximate the respective weights. The other gages are officially thickness gages.

Plates, over 6 in. to 48 in. wide,  $\frac{1}{4}$  in. and thicker; over 48 in. wide,  $\frac{3}{16}$  in. and thicker.

Sheets, 24 in. to 48 in. wide, under  $\frac{1}{4}$  in. thick; over 48 in. wide, under  $\frac{3}{16}$  in. thick.

Strip, 28  $\frac{1}{16}$  in. and narrower, under  $\frac{1}{4}$  in. thick.

‡ Formerly Washburn & Moen.

---

 Engineer
 

---

 REPORT ON STRUCTURAL STEEL—RIVETED OR BOLTED  
 FIELD INSPECTION
 

---

Report No. \_\_\_\_\_

Job \_\_\_\_\_ Date \_\_\_\_\_

Reported to \_\_\_\_\_ Temp. \_\_\_\_\_

	Erected during this period	Erected to date	Plumbed	Riveted	Accepted
Columns					
Beams					

Worked from approved erection plans and specifications \_\_\_\_\_

The fact that shop inspection has been made has been verified \_\_\_\_\_

All steel accepted has been inspected and approved as follows with special attention to the following:

All members have been checked against plans for piece mark and location

Column bases, leveled and grouted \_\_\_\_\_

Columns plumbed \_\_\_\_\_

Riveting where called for on plans \_\_\_\_\_ Quality \_\_\_\_\_

Bolting quality \_\_\_\_\_

Painting \_\_\_\_\_

Every column splice has been inspected for true bearing \_\_\_\_\_

Ends of beams on seat connections are within  $1\frac{1}{16}$  in. maximum of face of supporting members \_\_\_\_\_

Remarks (rejections, corrections, etc.) \_\_\_\_\_

---

 Inspector
 

---

---

 Engineer
 

---

## REPORT ON STRUCTURAL STEEL—RIVETED OR BOLTED

## SHOP INSPECTION, PART I

Report No. \_\_\_\_\_

Job \_\_\_\_\_ Date \_\_\_\_\_

Reported to \_\_\_\_\_ Where Inspected \_\_\_\_\_

---

 Approved drawings used for inspection, shop drawings, erection plan,  
 joint details \_\_\_\_\_
 

---

Steel inspected for:

Surface defects, folds, twists, straightness \_\_\_\_\_

All sections called for on plans \_\_\_\_\_

Connections agree with details and for correct location \_\_\_\_\_

All members requiring bearing ends have full square-milled bearing \_\_\_\_\_

---

 Stiffeners are full in contact at both ends for plate girders and at the ends  
 shown in contact for seats and rolled sections \_\_\_\_\_
 

---

All skewed connecting angles and plates have been bent hot \_\_\_\_\_

---

 Rivets are tight and of correct diameter \_\_\_\_\_
 

---

The ends of beams bearing on seat connections will be not more than  $1\frac{1}{16}$  in.  
 maximum from the face of column or supporting member \_\_\_\_\_Not more than 2 of the rivets are punched more than  $\frac{1}{16}$  in. off for any  
 connections and not more than  $\frac{1}{4}$  in. in any case \_\_\_\_\_

Material has been properly cleaned before painting \_\_\_\_\_

Painting is according to specifications or drawings \_\_\_\_\_

Sample of shop coat paint has been taken for analysis \_\_\_\_\_

Inspector has marked every member after accepting same \_\_\_\_\_

No member has been shipped without inspector's mark except \_\_\_\_\_

Inspector has marked on plans and column schedule all members accepted \_\_\_\_\_

---

 Members have been assembled to insure proper alignment and fit, and free-  
 dom from twists, bends, and open joints between the component parts \_\_\_\_\_
 

---

Inspector will be able to state in final report that every member has been  
 covered \_\_\_\_\_

Special requests have been attended to \_\_\_\_\_

Remarks (rejections, corrections, attention to warning notes, etc.) \_\_\_\_\_

---

 Inspector
 

---



## STRUCTURAL STEEL

---

 Engineer

## REPORT ON STRUCTURAL STEEL

 SHOP INSPECTION, PART II  
 (For both riveted and welded steel)

Report No. \_\_\_\_\_

Job \_\_\_\_\_ Date \_\_\_\_\_

Reported to \_\_\_\_\_ Where Inspected \_\_\_\_\_

Material	Required	Being Fabricated	Finished	Shipments			Weights
				Date	R.R.	Car No.	

Remarks \_\_\_\_\_

Shipped this report \_\_\_\_\_

Previous \_\_\_\_\_

Total to date \_\_\_\_\_

---

 Inspector

# MILL REPORT

Mill _____ Client _____ Project _____	_____ Engineer	Date _____ Report _____ Sheet _____ of _____ Specification _____
<b>STEEL MILL REPORT *</b>		

**Requirements**

Quantity	Description of Material	Weight	Heat Number	Yield Pt. Per Sq. In.	Ultimate per Sq. In.	% Elongation In.	% Reduction Area	Bend	Chemical Tests			
									Car.	Man. Phos.	Sul.	

Total this report \_\_\_\_\_  
 Previous \_\_\_\_\_  
 Total to date \_\_\_\_\_

The above tests do \_\_\_\_\_ fulfil A.S.T.M. Spec. \_\_\_\_\_, \_\_\_\_\_ Grade  
 do not \_\_\_\_\_

\* Adapted from Haller Engineering Associates, Inc. \_\_\_\_\_ Inspector

# WELDING

## COMMON WELDING PROCESSES

Figures 22 and 23 indicate common welding processes and the action of the shielded arc electrode. In the electric arc welding process a metal electrode is melted and fuses with contiguous metal surfaces to be joined. The welding heat is obtained from the electric arc formed between the electrode and the parts to be welded. The temperature of the arc is approximately 10,000° F.

In the metal arc process if the direction of flow of current is through ground lead, into work, into electrode, and back to machine, the circuit is known as electrode negative (straight polarity). With the electrode positive (reverse polarity) the direction of the flow of current is reversed. In alternating-current welding the direct-current generator is replaced by a transformer. Direct current with electrode positive (reverse polarity) is used for structural work except where deep penetration is required. The type of electrodes affects the polarity, as electrodes can be used only as shown in Table 21, p. 68, on account of the material of the covering.

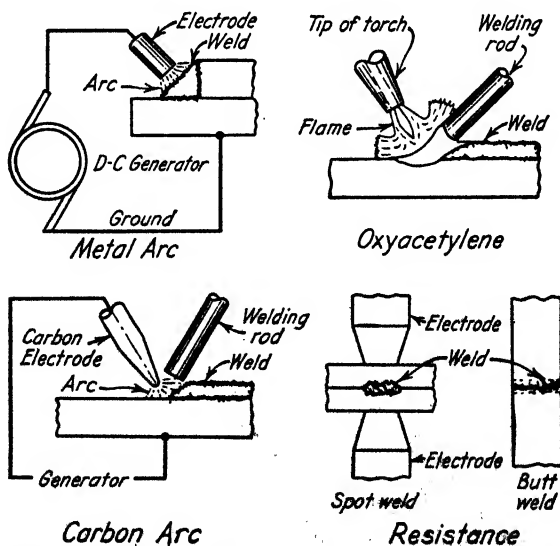

FIG. 22. Welding processes. From H. Malcolm Priest, *Practical Design of Welded Steel Structures*, American Welding Society.

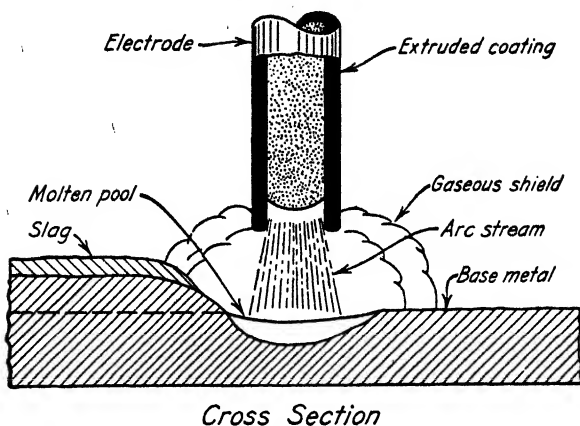

FIG. 23. Shielded arc electrode. From H. Malcolm Priest, *Practical Design of Welded Steel Structures*, American Welding Society.

### WELDERS' QUALIFICATION TEST USING FILLET WELDS

Take two bars 5 in. by  $\frac{1}{2}$  in. by 4 in., and weld as indicated in Fig. 24 in the desired position, that is, flat, horizontal, vertical, or overhead. Turn plates over and break with a blow by a sledge hammer. The weld should break cleanly along the center line, showing a clean cross section of weld material. Visual inspection of the weld and its fracture readily reveals any improper fusion between the weld and base metal or any lack of soundness.

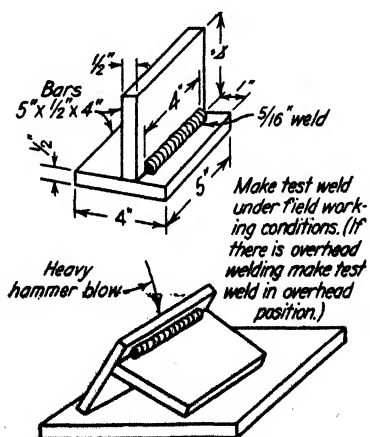

FIG. 24. Test for weld soundness.

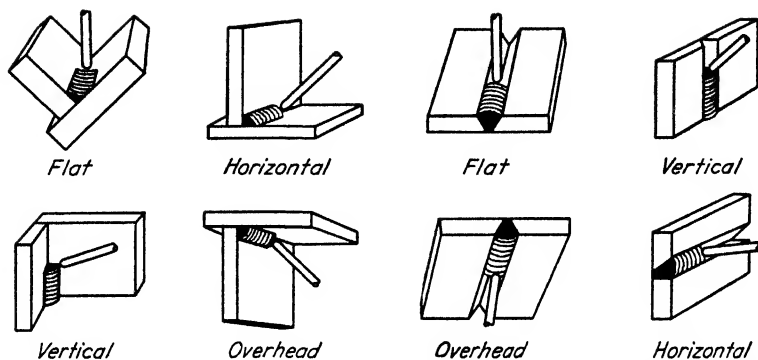

FIG. 25. Welding positions. From H. Malcolm Priest, *Practical Design of Welded Steel Structures*, American Welding Society.

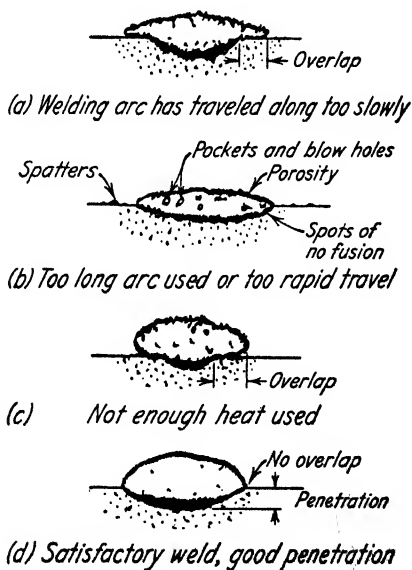
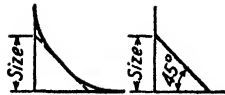
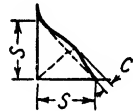

FIG. 26. Weld characteristics under certain conditions. From Gilbert D. Fish, *Arc-Welded Steel Frame Structures*, McGraw-Hill Book Company.



Desirable fillet weld profiles



Convexity, *C*, shall not exceed  $0.1S + 0.03$  inch.

Acceptable fillet weld profile

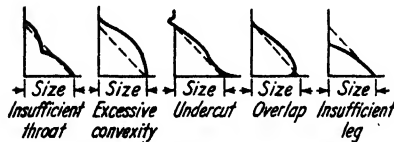

Defective fillet weld profiles

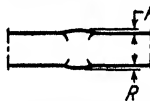

Reinforcement, *R*, shall not exceed  $\frac{1}{8}$  inch.

Acceptable butt weld profile



Defective butt weld profiles

FIG. 27. Illustrations of acceptable and defective welds as contained in A.W.S. Code. From Specifications for Design, Fabrication and Erection of Structural Steel for Buildings by Arc and Gas Welding, 1942, American Institute of Steel Construction.

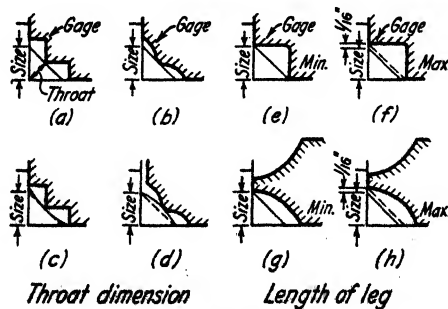

FIG. 28. Fillet weld gages. From H. Malcolm Priest, Practical Design of Welded Steel Structures, American Welding Society.

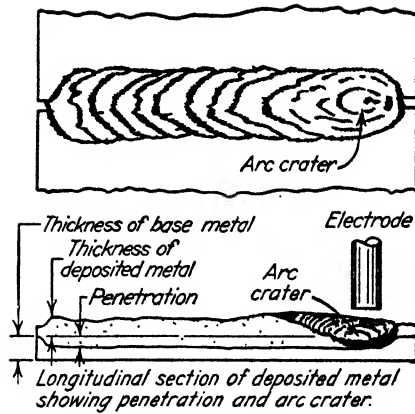

FIG. 29. Weld penetration and arc crater. From Gilbert D. Fish, *Arc-Welded Steel Frame Structures*, McGraw-Hill Book Company.

TABLE 21. ELECTRODES AND THEIR USES (A.W.S. SPEC.)

ELECTRODE CLASSIFI- CATION NUMBER	CAPABLE OF PRODUCING SATISFACTORY WELDS IN POSITIONS SHOWN	GENERAL DESCRIPTION	REMARKS
E6010	<i>F, V, OH, H</i> *	Heavy covering, useful with direct current, electrode positive (reverse polarity) only.	These electrodes, called slow electrodes, are used in both shop and field. They produce a slower weld than E6020 and E6030.
E6011	<i>F, V, OH, H</i>	Heavy covering, useful with alternating current only.	The weld pool can be controlled in all positions. E6010 is used for root pass of flat welds.
E6012	<i>F, V, OH, H</i>	Heavy covering, usually used with electrode negative (straight polarity), direct or alternating current.	
E6013	<i>F, V, OH, H</i>	Heavy covering, usually used with alternating current.	

ELECTRODE CLASSIFI- CATION NUMBER	CAPABLE OF PRODUCING SATISFACTORY WELDS IN POSITIONS SHOWN		GENERAL DESCRIPION	REMARKS
E6020	<i>F, H</i>	fillets	Heavy covering, usu- ally used with elec- trode negative (straight polarity) or alternating cur- rent for fillets; and electrode positive (reverse polarity) or alternating current for flat welding.	These electrodes, called fast electrodes, are usually used in shop and only in posi- tions indicated as weld pool has to be con- trolled by fast welding.
E6030	<i>F</i>		Heavy covering, usu- ally used with elec- trode positive (re- verse polarity) on direct current, or with alternating cur- rent.	

\* *F* = flat; *V* = vertical; *OH* = overhead; *H* = horizontal.

TABLE 22. MAXIMUM SIZE OF ELECTRODES

TYPE	POSITION				<i>Note:</i> Maximum size of fillet weld in one pass is $\frac{5}{16}$ in., ex- cept that vertical welds can be $\frac{1}{2}$ in.
	Flat	Horizontal	Vertical	Overhead	
Fillet	$\frac{1}{4}$ in.	$\frac{5}{16}$ in.	$\frac{3}{16}$ in.	$\frac{3}{16}$ in.	
Butt	$\frac{1}{4}$ in.	$\frac{3}{16}$ in.	$\frac{3}{16}$ in.	$\frac{3}{16}$ in.	

Electrodes for a single pass fillet weld and for root pass of a multilayer weld shall be of proper size to insure thorough fusion and penetration with freedom from slag incursions, but shall not exceed  $\frac{5}{32}$  in. diameter for butt welds, vertical and overhead fillet welds.

Read off electrode container recommended current. Check vs. current being used.

To find current being used, time rate of electrode burn-off, find current from chart on following page.

**EXAMPLE.** Given  $\frac{5}{32}$  electrode and burn-off rate of 12 in. in 70 seconds.  
Enter chart at 70 seconds, proceed across to intersection with  $\frac{5}{32}$  in. curve, drop vertical to ampere scale, read 150 amperes.



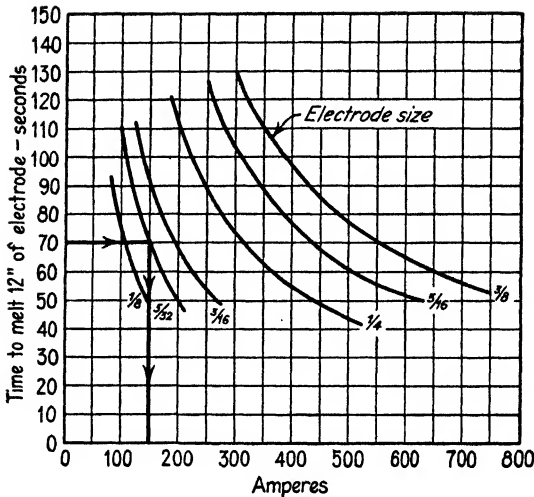

Chart to determine welding current by rate of electrode melt-off. From *Procedure Handbook of Arc Welding—Design and Practice*, The Lincoln Electric Company.

## CHECK LIST FOR INSPECTORS

### WELDING

See also "Check List for Inspectors, Structural Steel," p. 53.

#### Extra Equipment for Structural Welded Job

- Welding gage.
- Chipping hammer.
- Wire brush.
- Protective shield.

#### Procedure in Inspection

Qualifications of welder. If there is any question as to his qualifications, he should be required to make test pieces for inspector.

Conformity of electrodes to specifications or correct usage. See p. 68. For current actually used, see above chart.

Condition and capacity of welding equipment.

Quality of welds for overlap, color, porosity, slag inclusions, undercutting, uniformity, and workmanlike appearance.

Fitting up of members for tightness. In fillet welds when the gap exceeds  $\frac{1}{16}$  in., size of weld should be increased.

Sequence of welding in order to minimize residual stresses.

Condition of any tack welds which are to be fused with final welds. If any of these are not satisfactory, they should be removed.

Cleanliness of work, as good welds cannot be made on dirt, rust, or slag. In a multiple pass weld, slag must be chipped and wire brushed to shiny surface before next pass is made.

Weather conditions, as welding should not be done in temperature less than 0° F., or when surfaces are wet from condensation, rain, snow, or ice. Welder should be properly protected from wind. At temperatures between 0° F. and 32° F., surfaces must be heated. Material 1½ in. thick or over should be 70° F. minimum.

Conformity to approved plans for the following details:

Cross-sectional size, length, location, and omission. They should not be increased arbitrarily as longer welds sometimes introduce more restraint than calculated.

Operator at work at frequent intervals. If welding is not being properly done, he should be corrected. An experienced welder knows when he is making a good weld. He also knows whether equipment is working properly and will tell you.

#### IDENTIFICATION OF IRON AND STEEL

	WHITE CAST IRON *	GRAY CAST IRON	MALLEABLE † IRON
Fracture	Very fine silvery white silky crystalline formation	Dark gray	Dark gray
Unfinished surface	Evidence of sand mold; dull gray	Evidence of sand mold; very dull gray	Evidence of sand mold; dull gray
Newly machined	Rarely machined	Fairly smooth; light gray	Smooth surface; light gray
	WROUGHT IRON	LOW-CARBON STEEL AND CAST STEEL	HIGH-CARBON STEEL
Fracture	Bright gray	Bright gray	Very light gray
Unfinished surface	Light gray smooth	Dark gray; forging marks may be noticeable; cast—evidences of mold	Dark gray; rolling or forging lines may be noticeable
Newly machined	Very smooth surface; light gray	Very smooth; bright gray	Very smooth; bright gray

\* Very seldom used commercially.

† Malleable iron should always be bronze-welded.

---

 Engineer
 

---

 REPORT ON STRUCTURAL STEEL—WELDED  
 FIELD INSPECTION
 

---

 Project \_\_\_\_\_ Date \_\_\_\_\_  
 Welding permit No. \_\_\_\_\_ Report No. \_\_\_\_\_  
 Welding contractor \_\_\_\_\_  
 Description of work \_\_\_\_\_
 

---

	Erected during this Period	Erected to Date	Plumbed	Welded	Accepted
Columns					
Beams					

 Shop welded or riveted \_\_\_\_\_  
 Weather and temperature \_\_\_\_\_  
 Checked against approved typical details and erection plans \_\_\_\_\_
 

---

 Machines \_\_\_\_\_
 

---

 Electrodes \* \_\_\_\_\_ Sizes \_\_\_\_\_ Polarity \_\_\_\_\_
 

---

 Weld sizes \_\_\_\_\_ No. of layers or beads \_\_\_\_\_ Symbol \_\_\_\_\_
 

---

 Positions employed: horizontal \_\_\_\_\_ flat \_\_\_\_\_ vertical \_\_\_\_\_
 

---

 overhead \_\_\_\_\_
 

---

 All welders' qualifications checked \_\_\_\_\_ Authority \_\_\_\_\_
 

---

 Has every welder marked joint with index number? \_\_\_\_\_
 

---

 Has inspector kept complete record of welding? \_\_\_\_\_
 

---

 Has every weld been checked for size? \_\_\_\_\_ Length? \_\_\_\_\_
 

---

 Location? \_\_\_\_\_ Quality? \_\_\_\_\_ Workmanship? \_\_\_\_\_
 

---

 Number of individual welds made: \_\_\_\_\_ Accepted: \_\_\_\_\_
 

---

 Rewelded: \_\_\_\_\_
 

---

 Reasons for rejections and rewelding, method of correction of defective welds, and name and index numbers of welders making such defective welds:
 

---

 \_\_\_\_\_
 

---

 \_\_\_\_\_
 

---

\* See p. 68.

Inspector has marked on plans all joints accepted including column splices using separate prints where plans cover two or more tiers \_\_\_\_\_

Before welding was the steel properly cleaned, and free from corrosion, water, oil, scale, dirt, paint, etc.? \_\_\_\_\_

Were proper methods employed when setting up the work to insure tight fit without displacement of component parts after welding, together with full penetration of the weld metal to the root of the joints? \_\_\_\_\_

Was inspector in full attendance at all times while welds or fusion was being made in the passing of metal from the electrode to the base metal? \_\_\_\_\_

Was each completed weld carefully examined for defects and irregularities such as: undercutting, overlaps, lack of fusion at edges, lack of penetration, place cracks adjacent to or behind weld, water cracks and cracks in weld metal, slag inclusions? \_\_\_\_\_

Remarks \_\_\_\_\_

Joints welded and accepted \_\_\_\_\_

Inspector has marked every weld group after accepting them. \_\_\_\_\_

\_\_\_\_\_  
Inspector

---

 Engineer
 

---

REPORT ON STRUCTURAL STEEL—WELDED  
 SHOP INSPECTION, PART I  
 (See p. 62 for Part II.)

---

 Report No. \_\_\_\_\_  
 Job \_\_\_\_\_ Date \_\_\_\_\_  
 Reported to \_\_\_\_\_ Where inspected \_\_\_\_\_
 

---

Approved drawings used for inspection, shop drawings, erection plan,  
 joint details \_\_\_\_\_

Steel inspected for surface defects, fold, twists, straightness \_\_\_\_\_

All sections are as called for on plans \_\_\_\_\_

Connections agree with details and for correct locations \_\_\_\_\_

All members requiring bearing ends have full square-milled bearing \_\_\_\_\_

---

Stiffeners are full in contact at both ends for plate girders and at the ends  
 shown in contact for seats and rolled sections \_\_\_\_\_

All skewed connecting angles and plates have been bent hot \_\_\_\_\_

---

The ends of beams bearing on seat connections will be not more than  $1\frac{1}{16}$   
 in. maximum from the face of column or supporting member \_\_\_\_\_

---

Material has been properly cleaned before painting \_\_\_\_\_

Painting is according to specifications or drawings \_\_\_\_\_

Sample of shop coat paint taken for analysis \_\_\_\_\_

Inspector has marked every member after accepting same \_\_\_\_\_

No member has been shipped without inspector's mark except \_\_\_\_\_

---

Inspector has marked on plans and column schedule all members accepted

---

Inspector will be able to state in final report that every member has been  
 covered \_\_\_\_\_

Every weld inspected for size \_\_\_\_\_ length \_\_\_\_\_  
 location \_\_\_\_\_ and quality \_\_\_\_\_

Every welder has marked every weld group for identification \_\_\_\_\_

All welders' qualifications checked \_\_\_\_\_ Authority \_\_\_\_\_

Number of welders \_\_\_\_\_ Names \_\_\_\_\_

---

Make and capacity of machines \_\_\_\_\_

Kind of current \_\_\_\_\_

Make, grade, style No., and size of electrodes \_\_\_\_\_

---

Special requests have been attended to \_\_\_\_\_

Remarks (rejections, corrections, etc.) \_\_\_\_\_

---

 Inspector
 

---

## BRIDGES

### Reports When under Construction

Structural steel	see pp. 60 to 63.
Concrete	see pp. 43 to 48.
Piles	see p. 88.
Timber	see p. 96.
Other items	

### Field Data Required for Rating Existing Bridges if Plans Not Available

Sizes of all members.

All span and panel point dimensions.

Sketches of all joints including dimensions and sizes of bolts, rivets, pins, connection angles, washers, etc.

Data for dead-load computations such as material and thickness of floor construction.

Live loads from using railroad or proper highway department.

### INSPECTION OF EXISTING BRIDGES \*

**Waterway.** First show the area of the structure in square feet in the space provided.

Conditions in the streambed should be noted as to (1) adequacy of channel afforded by the existing structure; (2) probability of scour that may endanger the footings; and (3) presence of obstructions, such as drift logs, stumps, or old piers, that may be diverting the current so as to cause undermining of the footings. Also note any undergrowth or obstructions that can be removed to increase the adequacy of the waterway or to lessen the fire hazard of timber structures. Lastly, note whether stream-bank protection is necessary to keep the channel properly confined and thus to avoid endangering the bridge foundations or the end fills. Also note if there are any indications of unusual corrosiveness at the site.

**Piers and Abutments.** The type and material used should be listed.

**Timber Piles.** Piles supporting timber bridges should be inspected carefully at the ground line, where decay first sets in. A  $\frac{3}{4}$ -in. hexagonal steel bar about 4 ft. long, with one end sharpened to a long tapering point and the other end provided with a chisel face, is a very useful tool in such examinations. It can be jabbed into a pile to disclose deterioration not apparent on the surface and to determine the extent of sap rot. Piles in which the diameter of sound material has been reduced to 6 in. or less should be marked with yellow keel for replacement.

\* From *Toncan Culvert Manuf. Assoc.*

**Steel Tubular Piers.** Steel tubular piers should be carefully examined for corrosion in rivets or bolt heads connecting the cylindrical sections. (The filling material in such steel cylinders is usually inferior and without strength in itself.) Also note whether there has been appreciable movement of the tubes due to impact of heavy loads on the structure; if so, additional footings or bracing may be needed. Note whether the steel tubes are out of plumb and if so whether this is due to undermining, to lack of proper bracing, or to inadequate support below. Examine base of tubes for exposed piling caused by scour.

**Concrete Substructures.** The pier shafts should be examined for damage from drift or ice. Examine exposed footings for rock pockets due to improper placement of concrete. Note extent of any undermining. Look for cracks, and note whether they are caused by unequal settlement, contraction, or fill pressure. Check abutments and adequacy of wing walls. Recommend placement of riprap and rock slope protection where necessary.

### Concrete Structures

**Culverts.** Examine barrel and wing walls of culverts to find any harmful cracks due to settlement that should be grouted to prevent deterioration of the reinforcing steel. Also examine floor of barrel to note any upheaval which may cause failure of side walls due to excessive fill pressure; especially note this in culverts under high fills.

**Beam-and-Slab Spans.** Note condition of railing for damage by collision; sight alignment of railing for indication of settlement of the structure. On heavily traveled roads, the handrail should be kept clean in order to provide proper visibility for night driving and, if conditions warrant, should be painted with a cement wash coat. Examine beams for cracks that may be due to clogged expansion joints, settlement, or fill pressure at either end of bridge. Note any surface checking in deck, railing, curbs, or sidewalks that may allow water to seep in and cause disintegration by freezing action.

### Steel Structures

On steel trusses note first the general alignment of the span to see whether the end posts and top chords are straight and in line. Any buckling indicates that the structure has been overloaded. Especially note this for light construction. Kinks in any one member may have been caused by damage in shipment, in erection, or by collision; the inspector should satisfy himself that any such kinks are not due to overstress.

For all pin-connected trusses, note whether eyebars in the same member are taking equal tension. Overloading or lack of proper camber adjustment may cause one eyebar to take all the stress, leaving the others loose on the pin. Especially note this for the diagonal and hip vertical mem-

bers. Observe the structure under heavy loading, and note whether there is any excessive deflection or bowing in or out of the diagonal eyebar members which would indicate lack of proper counterbracing. Note condition of end shoes and rollers to see whether proper expansion is being provided for and whether the rollers are free to move.

### Timber Structures

**Timber Trusses.** In inspecting a timber truss, first see if it has any noticeable sag. If sag is present note whether it is due to failure of splices, improper adjustment of vertical rods, or crushing of diagonal members. Examine all splices for splitting or cracking of the shear tables. Sound the rods with a hammer to note whether each is carrying the same amount of tension, and examine condition of caps and ends of diagonal members for signs of crushing. If the structure is very old, it will be advisable to use a  $\frac{3}{8}$ -in. auger bit to test out the center of the top and bottom chord members for heart rot at all panel points and splices; the floor beams at contact with bottom chords should also be bored. Decay will be found first at contact points and where rods go through timber members.

Other points to check on covered trusses will be the condition of the roof and housing. Be sure to examine truss bearings over the pier caps and the condition of caps over pier piling for crushing, and bore with auger bit where there is any doubt as to their soundness. Note whether all bolts through splices, packing blocks, and cross bracing are tight and in good order. The substructure of timber trestles should be examined as directed under "Piers and Abutments." Caps should be examined for any crushing over the posts or piling. Decay will always be found first at bearing contacts, and a testing bar or auger bit should be used on all doubtful timbers. A thorough boring test must be made on all timbers that have been in place more than 6 years.

Note condition of bulkheads at each end of the bridge for decay, height, and proper retention of approach fill. Check sway and longitudinal bracing to note whether any members are broken or decayed and whether additional bracing is required. In examining the superstructure, first go under the bridge, examine each span, and note (1) whether stringers are crushing, cracking, or splitting, (2) whether they have full bearing over the caps, and (3) whether bridging between stringers is in place. Note condition of under side of decking, and see whether all bolts are properly tightened or have become loose due to shrinkage of timbers.

Second, examine deck and handrail from roadway. Especially on high bridges, sound handrail posts with testing bar at contact with felloe guard, stringers, and railing to see that members are not badly decayed. Handrail should be kept painted for protection against decay and to provide visibility for night traffic; all decayed members must be replaced. Timber handrails require repainting about every 3 years.



## FIELD DATA FOR NEW SMALL BRIDGES

The following bridge inspection report on p. 80 is devoted to data that should be gathered in the field for the replacement of an existing small bridge with a new structure. All data requested in the heading is self-explanatory; however, it should be emphasized that, if the existing structure is noticeably too small or too large, then the area to be drained, expressed as drainage area in acres, should be as accurate as possible. Likewise, the correct value for  $c$  should be shown for use in the Talbot formula.

Fill in the data requested for the respective type; however, if a decision as to proper selection has not been made, it is advisable to list the data for both pipe and arches since very little extra time will be required to develop the additional information.

It is important that the profile of the stream bed and road and location sketch be as accurate as possible. Be sure to indicate on the location sketch any suggested desired change in location for the new structure.

## EXISTING BRIDGE INSPECTION REPORT \*

Bridge No. \_\_\_\_\_ Route No. \_\_\_\_\_ Miles from \_\_\_\_\_ Toward \_\_\_\_\_  
 Bridge over \_\_\_\_\_ Type \_\_\_\_\_ Date built \_\_\_\_\_  
 Overall length \_\_\_\_\_ Width between rail's \_\_\_\_\_ Vertical clearance \_\_\_\_\_  
 Load capacity \_\_\_\_\_ Approach(es) \_\_\_\_\_ Date inspected \_\_\_\_\_  
 H-10, H-15, or H-20  
 H 20-S16 or H 15-S:2

## OBSERVATIONS

Waterway Area _____ sq. ft.	Piers and Abutments Type _____	Concrete Structures and Floors	Steel Construction Type _____	Timber Spans and Floors
Adequacy _____	Undermining _____	Cracking _____	Condition of paint _____	Condition of paint _____
Scour _____	Settlement _____	Scaling _____	Corrosion _____	Decay _____
Obstructions _____	Cracking _____	Scour _____	Joints _____	Wear (floors) _____
Undergrowth _____	Disintegration _____	Settlement _____	Loose rivets _____	Structural defects? _____
Channel shifting _____	Decay (lumber) _____	Disintegration _____	Camber _____	Crushing at joints _____
Revetments _____	Corrosion (steel) _____	Waterproofing _____	End shoes _____	Splices _____
Other features _____	Other defects _____	Other defects _____	Other defects _____	Camber _____
	Piling foundations? _____		Wear _____	Other defects _____

Make above observations for each part of structure, and note with (✓) mark to indicate "OK" or "None." For items needing explanation mark with circle with a number inserted to refer to corresponding remark listed below. Amplify remarks with sketches on second sheet when necessary.

## REMARKS

(Use second sheet when space below is not sufficient; also, list causes of all defects such as cracking and scaling of concrete whenever possible.)

---



---



---

# INSPECTION REPORT

79

## RECOMMENDATIONS

(Furnish data on p. 80 when total replacement is recommended)

Item	Estimated Cost	
	Maintenance	Improvements

*Note.* List under maintenance and "Recommendations" all necessary channel clearing, revetments, bank protection, channel changes, stream-bed pavements, riprap work, underpinning or other foundation protection shoulder and slope protection, repairs to concrete work, painting, waterproofing, preservative treatments, repairs to roadway surfaces, repairs and renewals to timber and piling, and all other maintenance and repair work of whatever nature.

\_\_\_\_\_  
Inspector

\* From Toncan Culvert Manuf. Assoc.

† Under "Structural defects" note any tendency to warp, split, crack, etc.

## FIELD DATA FOR NEW STRUCTURE \*

Location \_\_\_\_\_ Width of roadway between outside of rails  
Same—New  
 or shoulders \_\_\_\_\_  
 Drainage area \_\_\_\_\_ Acres Talbot formula factor  $c =$  \_\_\_\_\_  
 Distance between stream bed and roadway \_\_\_\_\_  
 Slope of embankment \_\_\_\_\_ Type recommended \_\_\_\_\_  
Pipe—Arch

### ADDITIONAL DATA FOR PIPE STRUCTURE

Waterway area required \_\_\_\_\_ sq. ft. Live load \_\_\_\_\_  
 Cover over pipe \_\_\_\_\_ No. of pipes \_\_\_\_\_ Diameter \_\_\_\_\_  
 Slope or skew \_\_\_\_\_ Center line length \_\_\_\_\_  
 Headwalls or riprap \_\_\_\_\_ Type of material in stream bed \_\_\_\_\_  
 \_\_\_\_\_ Slope of stream \_\_\_\_\_ %

### ADDITIONAL DATA FOR ARCH STRUCTURE

Waterway area required \_\_\_\_\_ sq. ft. Live load \_\_\_\_\_  
 Cover over arch \_\_\_\_\_ No. of arches \_\_\_\_\_ Span \_\_\_\_\_  
 Rise \_\_\_\_\_ Slope or skew \_\_\_\_\_  
 Center-line length \_\_\_\_\_ Head walls or riprap \_\_\_\_\_  
 Bearing power of soil \_\_\_\_\_ Type of material in stream bed \_\_\_\_\_  
 Recommended material for abutments, piers, and walls \_\_\_\_\_  
 Depth of abutments and piers below stream bed \_\_\_\_\_  
 Slope of stream \_\_\_\_\_ %

Profile of stream and road.	
Note. Indicate normal and flood level of stream.	
Location sketch	
Show angle of skew of structure with centerline of roadway.	

\_\_\_\_\_  
Inspector

\* From *Toncan Culvert Manuf. Assoc.*

# PAINING

## CHECK LIST FOR INSPECTORS

### TREATMENT OF SURFACES FOR PAINTING

#### General Conditions

All surfaces to be painted shall be thoroughly dry.

No exterior painting to be done in rainy, damp, or frosty weather.

Permit no interior painting until surfaces have become thoroughly dry. (By artificial heating if necessary.)

Allow no painting on metal surfaces to be welded. If such surfaces have been painted, paint is to be removed.

All surfaces must be of material in compliance with specifications. Surfaces must be checked for shop coat where called for in specifications.

#### Surface Preparation

**Metal Surfaces.** Remove dirt and mud by brushing and/or washing.

Remove grease and oil with benzine, naphtha, or turpentine.

Rust and scale to be removed with wire brush, steel scraper, or sand blasting.

Mill scale to be removed by burning.

Old paint to be removed by burning, scraping or paint remover.

Before painting over prime coat, check and reprime where necessary.

Before priming new galvanized metal wash with copper sulfate solution to remove grease and chemicals.

Before hot asphaltic applications, heat metal.

Where phosphoric acid treatment is specified, immerse material in caustic soda solution at 200° F. to remove grease and oils; rinse in hot water; immerse in 5% sulfuric acid pickle, then rinse in hot water.

**Wood Surfaces.** Remove dirt and dust with brush and rag.

Stop out all knots and sap streaks with shellac.

Putty nail holes, cracks, and other depressions after primer coat has thoroughly dried. Tint putty to match finish.

Old paint to be removed by sanding, wire brushing, scraping, or burning.

Floors to be sanded or scraped.

Open-grained woods to be varnished to be given first an application of wood paste filler thinned with turpentine.

**Masonry Surfaces.** Dust, dirt, and excess material to be removed with stiff bristle or wire brush.

Remove salts from brickwork with zinc sulfate water solution, and brush off surface when dry.

All masonry surfaces to be allowed thorough period for curing.

Porous block to be primed with casein paste or resin sealer.

Cement floors to be prepared by acid etching with muriatic acid to

improve adhesion; acid to be washed off and floor dried before painting.

Stucco and concrete to be cleaned with stiff fiber brush; traces of oil to be removed with abrasive stone or, if general, by light sand blasting. Sealer to be added to the paint.

Smooth dense concrete surfaces to be roughened by light sand blasting, muriatic acid etching, or rubbing with abrasive stone to improve adhesion.

Where cement paints are used on exterior concrete the surface to be dampened before application.

**Plaster Surfaces.** Allow 30 days for drying before painting.

Apply prime coat of sealer to clean dry surface.

Check prime coat for fading caused by hot spots (incomplete mixing of hydrated lime) and suction spots (thin spots and inadequate troweling).

## FOUNDATIONS ON SOIL

*Method of conducting a load test, N. Y. City code. See also Fig. 30, p. 83.*

**Procedure.** Apply sufficient load uniformly on platform to produce a center load of four times the proposed "design load per square foot."

Center load equals load of platform times  $\frac{b}{a + b}$ .

Read settlement every 24 hours until no settlement occurs in 24 hours.

Add 50% more load and read settlement every 24 hours until no settlement occurs in 24 hours.

Settlement under proposed load should not show more than  $\frac{3}{4}$  in., or increment of settlement under 50% overload should not exceed 60% of settlement under proposed load.

If the above limitations are not met, repeat test with reduced load.

**TABLE 23. PRESUMPTIVE BEARING CAPACITY OF SOILS**

MATERIAL	CAPACITY IN TONS PER SQ. FT.
Hard sound rock	40
Medium hard rock	25
Hard pan overlaying rock	10
Soft rock	8
Gravel	6
Coarse sand	4
Fine dry sand	3
Hard dry sand	3
Sand and clay, mixed or in layers	2
Firm clay	2
Fine and wet sand (confined)	2
Soft clay	1

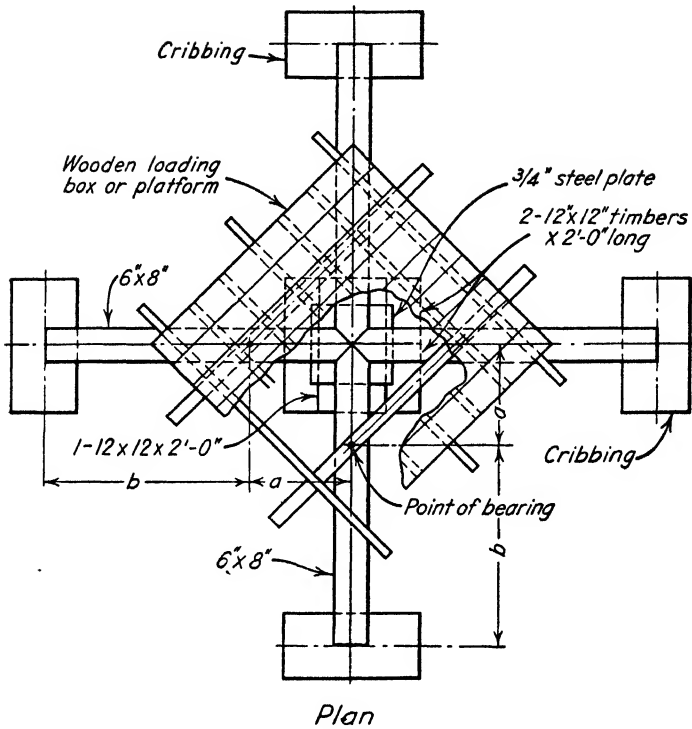

*Note: This distance determined by necessity of getting sight on bench mark with level.*

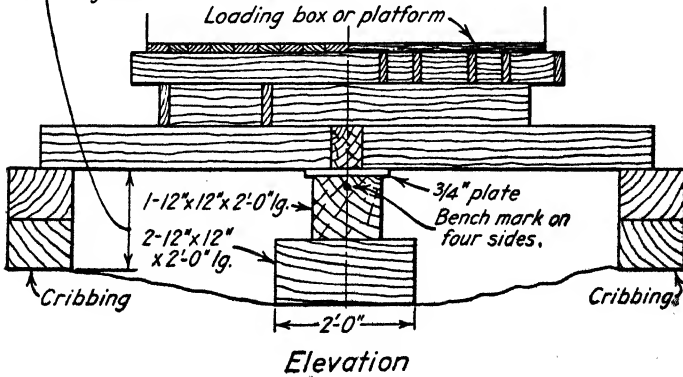

FIG. 30. Load test on soil.

**CHECK LIST FOR INSPECTORS****FOUNDATIONS**

Inspector should determine from plans the type of soil on which the foundation design is based and check against actual conditions.

Shallow pipe borings under each footing should be made if there is a question about the underlying soils.

If there is any question in regard to soil bearing capacity, inspector should notify engineer, who may according to his judgment revise size of footings or require footings to be carried deeper. Soil test may be required.

Keep footings clear of water when concrete is poured.

Soil to be original strata and below loam or vegetation.

Bottom elevation of footing to be at least the elevation called for on plan. If necessary, owing to soil condition, elevation may be lowered for suitable bearing.

Keep record of actual elevation of footings installed.

Check slope between footings when elevations differ from plans or when determined in field. This slope should not be more than 2 horizontal to 1 vertical for compact soils but should be fixed by the engineer.

Conditions which may require sheeting where impossible to keep minimum slope should be watched.

Possible undermining of existing foundations should be checked.

Footings should be of size shown on plans.

Concrete for footing. See "Instructions to Inspectors, Concrete."

**PILE DRIVING****CHECK LIST FOR INSPECTORS AND DATA****PILE DRIVING****Procedure in Inspection**

Inspector should first determine from specifications the type of pile to be used, should familiarize himself with specifications, and should have approved drawings for his use in field.

Condition of pile or pile shells before driving.

Type of pile driver and size. Weight of striking part or ram and stroke.

Plumbing of pile or mandrel before driving.

Lateral tolerance of pile. Limit 3 in. from horizontal location.

Plumbness of pile. Limit 2% of pile length.

Pile shell just before concrete is poured with light for: buckling of shell, puncture of shell, water, ice, and snow.

Buckling of cast-in-place pile when another pile is being driven close. This can be detected by watching the concrete rise in shell. If concrete rises to any extent, pile should be replaced.

Heaving of pile when another pile is being driven close. This can be noticed by watching to see if the shell is being lifted out of ground. Condition may be relieved by driving an occasional open-end pipe pile.

Check concrete mix from specifications or drawings.

Protection of concrete against freezing.

Pile caps not laid on frozen ground.

Proper cutoff.

Injury to wood piles. Crushing or brooming of pile head or, in precast concrete piles, the cracking or disintegrating of concrete makes it impossible to drive piles properly as this dissipates the energy of the blow of hammer.

Possible telescoping or crushing of the middle of wooden piles as indicated by sudden loss of resistance.

Possible deflection of the foot of pile. This happens when pile hits a slanting surface of rock and then drives easier as result of the splitting or sliding of the bottom.

**Driving Control.** Check length of piles and blows per inch. Calculate required safe load on each pile as follows:

For drop hammer  $P = \frac{2WH}{S + 1}$ ; for single-acting steam hammer,  $P =$

$\frac{2WH}{S + 0.1}$ . The reason for the difference in the formulas is the extra speed

of the steam hammer, which affects consolidation time between blows. Both are gravity-type hammers.

$P$  = safe load in pounds;  $W$  = weight of striking part in pounds;  $H$  = height of fall in feet or stroke in feet;  $S$  = average penetration in inches under last 5 blows.

**EXAMPLES.** Given  $W = 2000$  lb.,  $H = 15$  ft. 0 in.,  $S = 0.5$  in. Required  $P$  using drop hammer

$$P = \frac{2 \times 2000 \times 15}{0.5 + 1} = 40,000 \text{ lb.}$$

Given  $W = 5000$  lb.,  $H = 3$  ft. 0 in.,  $S = 0.4$  in. Required  $P$  using single-acting steam hammer

$$P = \frac{2 \times 5000 \times 3}{0.4 + 0.1} = 60,000 \text{ lb.}$$



**TABLE 24. BEARING POWER OF PILES IN THOUSANDS OF POUNDS DRIVEN WITH SINGLE-ACTING STEAM PILE HAMMERS AS PER FORMULA GIVEN IN TEXT**

SIZE OF HAMMER	WEIGHT OF STRIKING PART IN POUNDS	LENGTH OF STROKE IN FEET	PENETRATION PER BLOW IN INCHES									
			0.1	0.2	0.3	0.4	0.5	0.6	0.7	0.8	0.9	1.0
2	3000	2.42	73	48	36	29	24	20	18	16	14	13
1	5000	3.00	150	100	75	60	50	43	37	33	30	27
0	7500	3.25	244	162	122	97	81	69	60	54	48	44
OR	9300	3.25	302	202	152	121	101	86	75	67	60	55

Safe load for piles driven by double-acting steam pile hammer though usually prohibited in specifications for friction piles may be checked by the following manufacturer's data:

**Bearing Power of Piles Driven with McKiernan-Terry Pile Hammers.**

By the *Engineering News* formula,  $P = \frac{2E}{S + 0.1}$ , where  $P$  = safe load in pounds;  $E$  = energy or foot-pounds per blow (see Table 25);  $S$  = average penetration in inches for last 5 blows. The assumed safety factor of this formula is 6.  $E$  is computed from indicator diagram tests rather than from steam pressure.

**TABLE 25. VALUES OF  $E$  FOR MCKIERNAN-TERRY PILE HAMMERS**

SIZE OF HAMMER	FT-LB. BLOW AT GIVEN STROKES PER MINUTE		SIZE OF HAMMER	FT-LB. BLOW AT GIVEN STROKES PER MINUTE	
	Strokes per Min.	Ft-Lb. per Blow = $E$		Strokes per Min.	Ft-Lb. per Blow = $E$
7	225	4,150	9B2	100	3,700
	195	3,720		105	4,200
	170	3,280		110	4,750
9B3				115	5,350
	145	8,750	120	5,940	
	140	8,100	130	7,000	
	135	7,500	140	8,200	
10B3	130	6,800	10B2	100	10,700
	105	13,100		105	12,000
	100	12,000		110	13,500
	95	10,900		115	15,000
	90	9,550			
11B3			11B2	100	15,600
	95	19,150		105	17,250
	90	18,300		110	18,900
	85	17,500		115	20,500
			120	22,000	

**TABLE 26. BEARING POWER OF PILES IN THOUSANDS OF POUNDS USING MAXIMUM E**

PENETRATION PER BLOW IN INCHES	SIZE OF HAMMER						
	7	9B3	10B3	11B3	9B2	10B2	11B2
0.1	41.5	87.5	131.0	191.5	82.0	150.0	220.8
0.2	27.6	58.3	87.3	127.6	54.6	100.0	147.2
0.3	20.7	43.7	65.5	95.7	41.0	75.0	110.4
0.4	16.6	35.0	52.4	76.6	32.8	60.0	88.3
0.5	13.8	29.1	43.6	63.8	27.3	50.0	73.6
0.6	11.8	25.0	37.4	54.7	23.4	42.9	63.2
0.7	10.3	21.8	32.7	47.8	20.5	37.5	55.3
0.8	9.2	19.4	29.1	42.5	18.2	33.3	49.1
0.9	8.3	17.5	26.2	38.3	16.4	30.0	44.1
1.0	7.5	15.9	23.8	34.8	14.9	27.3	40.1

Comments. The field engineer's checking criterion is the number of strokes per minute, rather than the steam pressure, and also penetration. If steam pressure falls off, the number of blows per minute cannot be delivered and the penetration falls off.

### Load Tests

Conduct as follows. A suitable balanced platform shall be built on top of pile which has been in place for at least 2 days. If it is a concrete pile, the concrete should be thoroughly hardened. Place initial load equal to the proposed pile load using heavy material such as pig iron. Increase this load 25% after 12 hours, and 25% after 24 hours, thus the total load is 150% of proposed load.

Allow final load to remain at least 48 hours. Take readings before and after placing of each load and 12 and 24 hours after placing final load.

The total net settlement deducting rebound after removing load should not be more than 0.01 in. per ton of total test load.

\_\_\_\_\_  
Engineer

REPORT ON PILE DRIVING

FIELD INSPECTION

Report No. \_\_\_\_\_

Job \_\_\_\_\_ Date \_\_\_\_\_

Reported to \_\_\_\_\_

Hammer data \_\_\_\_\_

Foot- ing No.	Pile No.	Pene- tration	No. Blows Last In.	No. Strokes per Min.	Bearing Capacity	Ap- proved	Re- jected	Re- marks

See field drawing No. \_\_\_\_\_ for field location of piles in this report \_\_\_\_\_

\_\_\_\_\_  
Inspector

**TIMBER**  
**WOOD JOISTS—NET SECTION**  
**TABLE 27. SECTION MODULI =  $bd^2/6$**

Nom. Size	Actual Size	$S$	Nom. Size	Actual Size	$S$	Nom. Size	Actual Size	$S$	Nom. Size	Actual Size	$S$	Nom. Size	Actual Size	$S$
2 X 4	1 $\frac{1}{2}$ X 3 $\frac{3}{4}$	3.56	3 X 4	2 $\frac{1}{2}$ X 3 $\frac{3}{4}$	5.75	4 X 4	3 $\frac{3}{4}$ X 3 $\frac{3}{4}$	7.94	6 X 6	5 $\frac{1}{2}$ X 5 $\frac{1}{2}$	27.78	8 X 8	7 $\frac{1}{2}$ X 7 $\frac{1}{2}$	70.3
2 X 6	1 $\frac{1}{2}$ X 5 $\frac{1}{2}$	8.57	3 X 6	2 $\frac{1}{2}$ X 5 $\frac{1}{2}$	13.8	4 X 6	3 $\frac{3}{4}$ X 5 $\frac{1}{2}$	19.1	6 X 8	5 $\frac{1}{2}$ X 7 $\frac{1}{2}$	51.68	10 X 10	9 $\frac{1}{2}$ X 11 $\frac{1}{2}$	209
2 X 8	1 $\frac{1}{2}$ X 7 $\frac{1}{2}$	15.3	3 X 8	2 $\frac{1}{2}$ X 7 $\frac{1}{2}$	24.6	4 X 8	3 $\frac{3}{4}$ X 7 $\frac{1}{2}$	34.0	6 X 10	5 $\frac{1}{2}$ X 9 $\frac{1}{2}$	82.78	10 X 14	9 $\frac{1}{2}$ X 13 $\frac{1}{2}$	289
2 X 10	1 $\frac{1}{2}$ X 9 $\frac{1}{2}$	24.4	3 X 10	2 $\frac{1}{2}$ X 9 $\frac{1}{2}$	39.5	4 X 10	3 $\frac{3}{4}$ X 9 $\frac{1}{2}$	54.5	6 X 12	5 $\frac{1}{2}$ X 11 $\frac{1}{2}$	121	10 X 16	9 $\frac{1}{2}$ X 15 $\frac{1}{2}$	380
2 X 12	1 $\frac{1}{2}$ X 11 $\frac{1}{2}$	35.8	3 X 12	2 $\frac{1}{2}$ X 11 $\frac{1}{2}$	57.9	4 X 12	3 $\frac{3}{4}$ X 11 $\frac{1}{2}$	79.9	6 X 14	5 $\frac{1}{2}$ X 13 $\frac{1}{2}$	167	10 X 18	9 $\frac{1}{2}$ X 17 $\frac{1}{2}$	485
2 X 14	1 $\frac{1}{2}$ X 13 $\frac{1}{2}$	49.4	3 X 14	2 $\frac{1}{2}$ X 13 $\frac{1}{2}$	79.7	4 X 14	3 $\frac{3}{4}$ X 13 $\frac{1}{2}$	110.0	6 X 16	5 $\frac{1}{2}$ X 15 $\frac{1}{2}$	220	10 X 20	9 $\frac{1}{2}$ X 19 $\frac{1}{2}$	602

## HARDWOODS—RED OAK

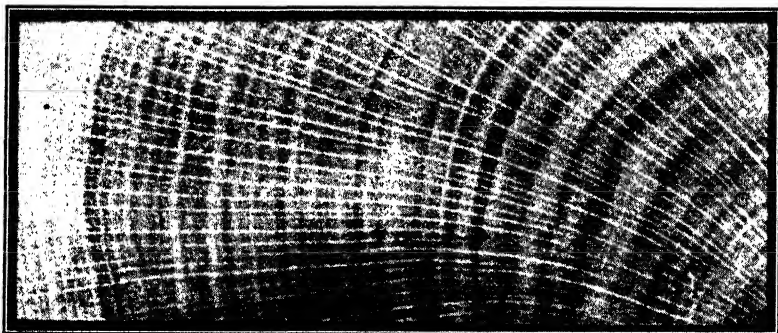

Transverse Section

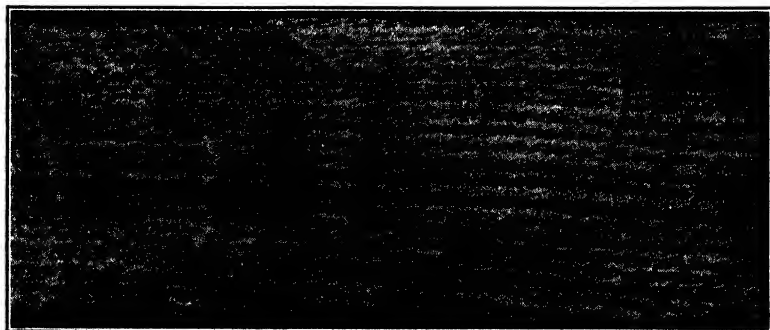

Radial Section

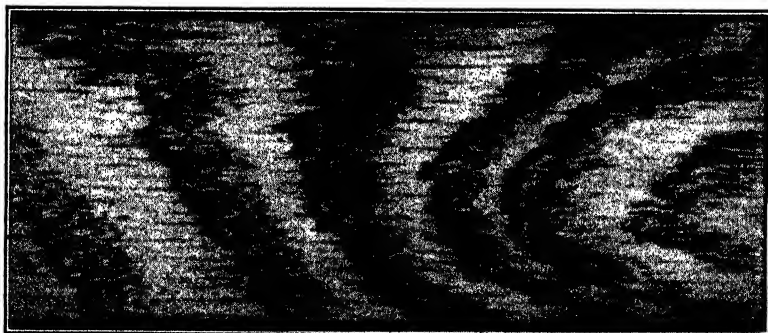

Tangential Section

This illustration is representative of the oaks, which are all very strong and suitable for the manufacture of anything from piles to furniture. The wood is very heavy, the white oak is the most resistant to decay.



- Tidewater Red Cypress { light with dark stain, decay resistant.
- Eastern Hemlock { light, brush, not easily dressed, slightly yellowish brown color.
- Eastern Spruce { whitish gray, soft texture, light and strong.
- Larch { fine-grained, light wood coming into wider use.
- Douglas Fir { the western counterpart of Long Leaf Yellow Pine, heavy for soft wood, distinctly reddish in color. Summer wood dark red, very hard. Splits easily but has good resistance against decay. One of the strongest soft woods.
- Short Leaf Yellow Pine { distinctly yellowish in color. Summer wood same color as spring wood. Coarse graining gives ornamental appearance when cut on tangential plane.
- Long Leaf Yellow Pine { counterpart of western fir except that it is yellow with a reddish cast. Summer rings dark colored, very dense. Wood gets its great strength from this feature. Used for wood trusses and high-class timber construction.
- Eastern White Pine { very soft, whittling wood with pungent odor, excellent for timber, color white to a slight pinkish.
- Greenheart { heavy, tough with distinct greenish tint; resistant to *Limnoria*, used for piling and dock work.

Identification of Common Soft Woods by Comparison



HARDWOODS—MAPLE

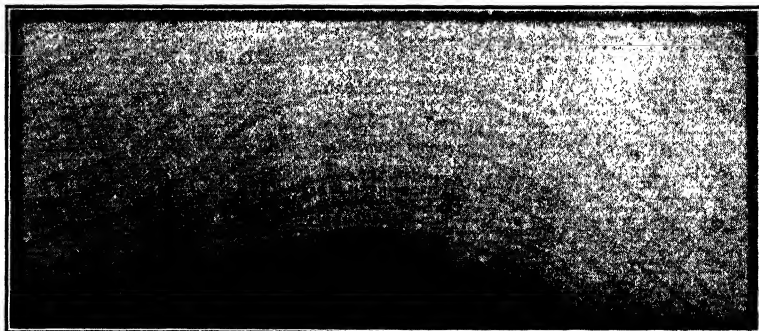

Transverse Section

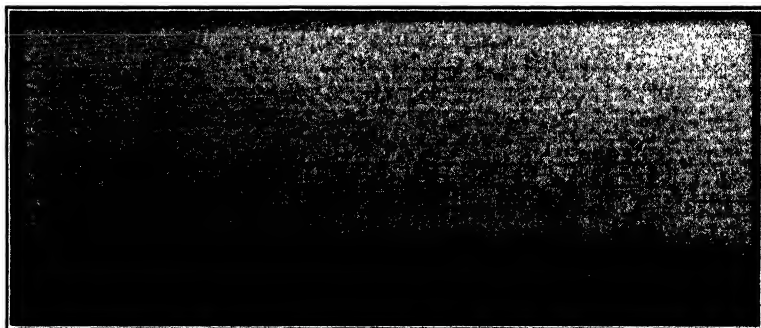

Radial Section

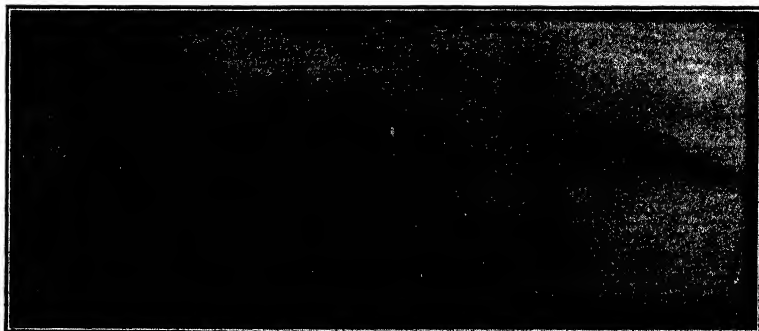

Tangential Section

This illustration is representative of the maples, an excellent flooring and furniture material but not used very much as structural timber.



**CHECK LIST FOR INSPECTORS****WOOD AND TIMBER CONSTRUCTION****Inspectors' Equipment**

Complete set of final structural plans, specifications, and approved shop details.

Copy of rules for stress grade of lumber.

6-foot rule.

Plumb bob.

Moisture meter.

**Procedure in Inspection**

Grade of lumber checked. Material should be stamped with grade shown on plans or called for in specifications. The inspector should familiarize himself with rules for grading of lumber to be used so that he may check grading if from appearance it looks incorrect.

Selection of already graded lumber checked. Select beams so as to avoid slope of grain in lower third of beam steeper than 1:20. Slope of grain in tension member of truss not to be steeper than 1:20. Avoid knots in lower edge of beams. By utilizing elsewhere or inverting pieces which do not conform, these results should be attained without waste.

Imperfections that may have occurred after grading, such as broken fibers due to transportation, decay, and moisture content, which should not be more than 20%, to be checked. Moisture content may be checked with moisture meter if available; otherwise inspector will have to accept manufacturer's certificate of moisture at time of grading plus visual inspection.

Increased checks, loose knots, and warping due to unsatisfactory seasoning watched.

Sizes, lengths and spacing of all members checked.

Bearing and anchorage of beam, girder, or joists on masonry checked.

Plumbing, base, cap, and splice details of columns, especially checking bearing at ends, checked.

All special details shown on plans carefully followed.

Correct fabrication of built-up member such as laminated members and trusses. All members with bolts and ring connectors should be fabricated with standard tools and strictly according to instructions furnished by manufacturer of same.

Drilling and grooving of ring connector members. Any material that is incorrectly drilled or grooved must be rejected as it is impossible to correct it.

Tightness of bolts in bolted or connected work. These should be tightened up so hard that washer makes a slight impression in wood surface but not so as to tear fibers. After construction until seasoning, bolts should be given a periodical inspection for tightness and at the same time timber should be inspected for further checking. This particularly applies to ring connectors or keyed work as ring or key tends to rotate as bolts loosen.

Alignment, bearing, or connection of trusses after erection. They should be straight and in a vertical position, and bearing or connection in accordance with plans.

Gluing of glued laminated members. This is usually done in a shop with proper facilities. Inspector should check to see that specifications are followed exactly with special attention to the following: type and quality of glue, mixing of glue, amount of glue used, method of applying, moisture content of lumber, curing of members, and temperatures of manufacturing space. In field watch for tendency of laminations to separate.

Retouching of cut, preserved members, see specifications.

---

 Engineer

 REPORT ON WOOD PRESERVATION \*  
 PLANT INSPECTION

Report for \_\_\_\_\_  
 Material \_\_\_\_\_  
 Project \_\_\_\_\_  
 Producer \_\_\_\_\_  
 Contractor \_\_\_\_\_ Specs. \_\_\_\_\_  
 Treatment No. \_\_\_\_\_ Report No. \_\_\_\_\_ Date \_\_\_\_\_  
 Charge No. \_\_\_\_\_ Preservative \_\_\_\_\_  
 Board feet \_\_\_\_\_ Treatment specified \_\_\_\_\_ Process \_\_\_\_\_  
 Lineal feet \_\_\_\_\_ Net retention \_\_\_\_\_  
 Cubic feet \_\_\_\_\_ Condition of \_\_\_\_\_  
 Steam \_\_\_\_\_ hours at \_\_\_\_\_ pounds maximum pressure \_\_\_\_\_ °F. maximum temperature  
 Vacuum \_\_\_\_\_ hours at \_\_\_\_\_ inches maximum pressure \_\_\_\_\_ °F. minimum temperature  
 Air \_\_\_\_\_ hours at \_\_\_\_\_ pounds maximum pressure \_\_\_\_\_  
 Preservative \_\_\_\_\_ hours at \_\_\_\_\_ pounds maximum pressure \_\_\_\_\_ °F. average temperature  
 Vacuum \_\_\_\_\_ hours at \_\_\_\_\_ inches maximum mercury \_\_\_\_\_ °F. minimum temperature  
 Special operation \_\_\_\_\_  
 Penetration \_\_\_\_\_ Specific gravity or preservative \_\_\_\_\_

---

No. Pieces	Size	Length	Total Treated	Total to Date
------------	------	--------	---------------	---------------

Remarks:

The above preservative and treatment fulfills the specification.

---

 Inspector

\* Adapted from Haller Engineering Associates, Inc.

## ROPES AND CABLE—STRENGTHS

## WEIGHT AND STRENGTH OF MANILA AND SISAL ROPE \*

Diameter, in.	Circumference, in.	Approx. Feet per Lb.	Ultimate Breaking Strength of Manila Rope (Min. Government Allowance), lb.	Safe Working Strains, lb.	Ultimate Breaking Strength of Sisal Rope (Min. Government Allowance), lb.	Safe Working Strains, lb.
1/4	3/4	50.0	600	120	480	96
3/8	1 1/8	24.4	1,350	270	1,080	216
1/2	1 1/2	13.3	2,650	530	2,120	424
3/4	2 1/4	6.00	5,400	1,080	4,320	864
1	3	3.71	9,000	1,800	7,200	1,440
1 1/2	4 1/2	1.67	18,500	3,700	14,800	2,960
2	6	.930	31,000	6,200	24,800	4,960

\* Adapted from American Manufacturing Company.

## WIRE ROPE 6 x 19 STANDARD HOISTING—PLOW STEEL \*

Diameter, in.	2 3/4	2 1/4	2	1 7/8	1 3/4	1 5/8	1 1/2	1 3/8	1 1/4	1 1/8	1	7/8	3/4	5/8	9/16	1/2	7/16	3/8
Breaking strength, tons of 2000 lb.	254.0	174.0	139.0	123.0	108.0	93.4	80.0	67.5	56.2	45.7	36.4	28.0	20.7	14.5	11.8	9.35	7.19	5.31

\* From John A. Roebling's Sons Company.

## VARIETIES OF KNOTS

A great number of knots have been devised, of which only a few are illustrated, but those selected are the most frequently used. See Fig. 31.

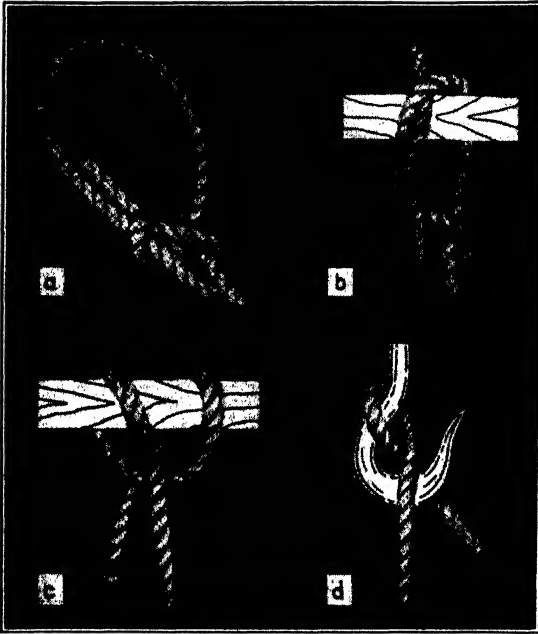

FIG. 31. *From American Manufacturing Company.*

- a. Bowline. Makes a slip-proof loop. Popular because it is easy to untie.
- b. Timber hitch. For securing a line to logs or planks. For lifting or dragging.
- c. Clove hitch. For attaching rope to a fixed object, or small rope to a larger one.
- d. Blackwall hitch. A temporary hook tie. More secure with two turns around hook.

**SOILS**  
**SURVEYING AND SAMPLING METHODS**  
**TABLE 28. EXPLORATION AND SAMPLING METHODS \***

Method	Material in Which Used	Penetration Method	Sampling Method	Type of Sample	Purpose or Value
Rod sounding or jet probing	All soils except hardpan or boulders	Driving 1 in. steel rod or $\frac{3}{4}$ in. jet pipe with hand pump	No sample		To obtain depth of muck or soft strata. Location ledge or boulders. Otherwise valueless.
Wash borings		Washing inside 2½ in. driven casing with chopping bit on end of 1 in. extra heavy pipe	Sample recovered from sediment in wash water	Disturbed-sedimentary, coarse grains only	Depth to ledge or boulders; otherwise valueless. Results deceptive and dangerous.
Dry sample boring			Open-end pipe or split spoon sampler driven into soil	Disturbed but not separated	Density data from penetration of spoon. Fairly reliable and inexpensive.
Special sampling devices	Cohesive soils	Driven casing or auger boring	By special sampling spoon or device	Undisturbed	To obtain samples for laboratory study
Auger boring	Cohesive soils. Cohesionless soils above ground water	Soil, wood or post hole; auger coated by hand or machine and withdrawn	Sample recovered from soil brought up by auger	Disturbed but better than wash samples	To locate soil strata and ground water. Roads, airfields, canals, and railroads. Samples for visual inspection and soil profile.
Well or churn drilling	All soils including boulders, rock, and gravel	Churn drilling by power	Bailed sample of churned material or use of "clay socket"	"Clay socket" or "dry"	Occasionally used for foundations. "Bailed" samples worthless.
Rotary drilling		Rotating bit	From circulating liquid	Fluid	Samples worthless
Core drill borings	Large boulders and solid rock	Diamond, shot, or saw-tooth cutters	Cores cut and recovered	Rock cores $\frac{3}{8}$ in. and over in diameter	Best method to obtain type and condition of rock
Test pits and caissons	All soils; below ground water use pneumatic caisson or tower water table	Excavate by hand or power; pit over 6 ft. sheeted or lagged	Bulk sample by hand; undisturbed sample with spoon, tube, or special device	Disturbed or undisturbed	Most satisfactory method; should supplement others. To obtain undisturbed sample cohesionless soil. Soil can be inspected in natural condition.
Geophysical, seismic, electric resistance, electric potential	No samples. Continuous vibrations. Mostly patented methods.	Continuous vibration or impulse from dynamite explosion.	Device to register		Primary exploration will indicate earth, loose rock, or solid rock. Interpretation uncertain.

\* Adapted from "Low Dams" by Natural Resources Comm., based on Harvard Grad. Eng. School Pub. 208 by H. A. Mohr.

## SPACING AND DEPTH OF BORINGS AND TEST PITS OR TEST HOLES

**Highways.\*** At 100 ft. stations plus additional necessary at culverts, bridges, weak zones, wide cuts and fills, muck deposits, borrow pits, and sources of base material. Depth not less than 3 ft. below subgrade. Locate ground water table, seepage sources, and direction of flow.

**Airfields.†** At 100-ft. to 1000-ft. spacing on center line, edge of pavement and edge of shoulders. Depth not less than 4 to 6 ft. below subgrade in cut or ground surface in fill. Not less than twice diameter of tire contact area nor less than frost penetration. Locate ground water table and seepage data. Make field load-bearing tests at time of survey (from 5 to 10 usual for each airfield).

**Bridges, Dams, and Piers.‡** Borings spaced as needed to bedrock or well below foundation level. Make borings at least 20 ft. into solid rock. Make 1 or more borings at each pier 50 ft. minimum into solid rock. Use open-pit exploration on land and in shallow water. Make soil bearing tests and pile loading tests.

**Building Foundations, Towers, Chimneys, etc.‡** Borings spaced not over 50 ft. center to center. Depth 15 ft. to 20 ft. minimum below foundation level. Initial borings to depth =  $2 \times$  width loaded area.

Core borings into rock greater than minimum design depth of rock required. Supplement borings with test pits, load tests, and test piles.

TABLE 29. SIZE OF SAMPLES

Visual inspection and record, 1 qt. mason jar.
California bearing ratio, 125 lb.
Soil stabilization, 125 lb.
Physical constants and mech. analysis, 5-15 lb.
Aggregates for construction (concrete), 35 lb.
Moisture-density (Proctor tests), 10-35 lb.
Undisturbed sample, 12" to 2' long x 3" to 5" diam.
Rock core, usually $\frac{3}{8}$ " to $1\frac{1}{2}$ " diam.

*Note.* Seal undisturbed samples in tube with paraffin so structure and moisture content are not disturbed. Place bulk (disturbed) samples in bag or container tight enough so fines will not be lost.

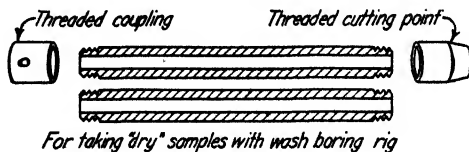

FIG. 32. Split spoon sampler.

\* A.S.T.M. D-420, C.A.A. Specs.

‡ Man. Eng. Practice 8, A.S.C.E.

† P.R.A., U.S.E.D., A.A.F., C.A.A.

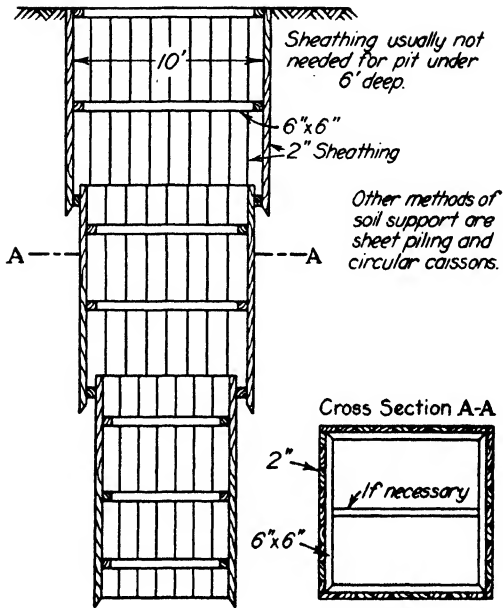
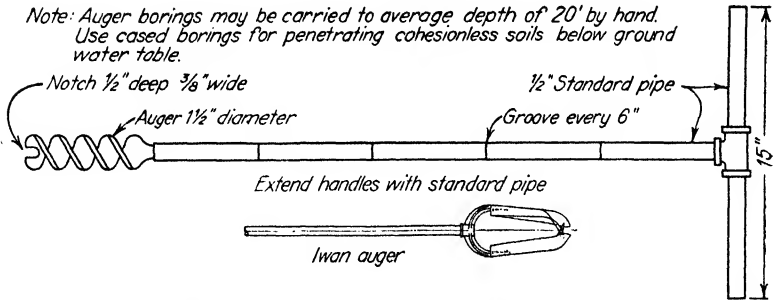

FIG. 33. Test pit (sheathed and braced). Krynine, *Soil Mechanics*, McGraw-Hill Book Company.



Other types used are 3" to 8" post hole augers for sands.  
 2" to 3" spiral auger for clay soils and muck.  
 Wood augers for hard soils, glacial till, etc.  
 10" to 20" power driven augers for gravel, etc.

Soil Augers

FIG. 34. Soil auger.



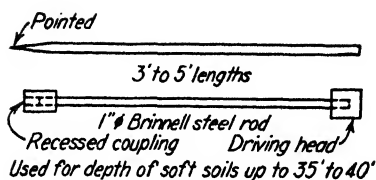

FIG. 35. Sounding rod.

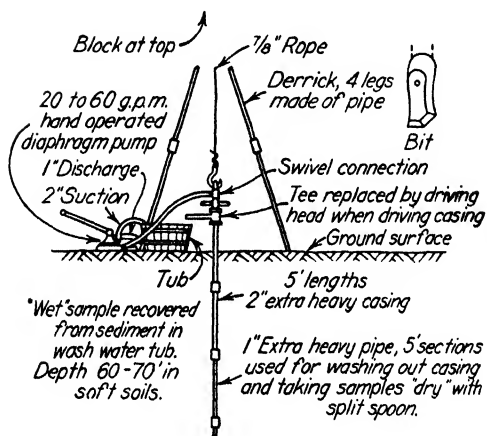

FIG. 36. Wash boring rig. After Mohr.

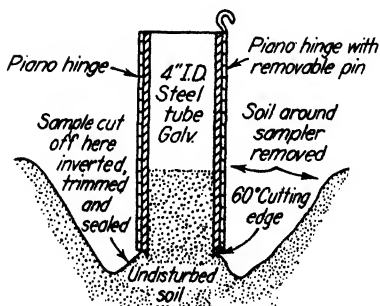
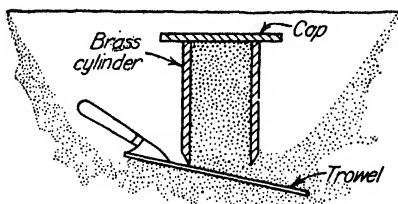
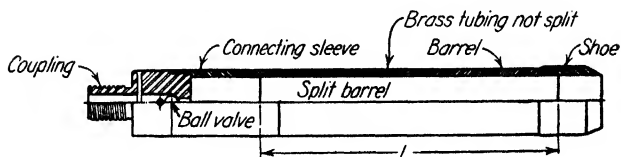

FIG. 37. Shallow sampler for cohesive soil. After Taylor.



Cylinder is worked into soil by hand.  
Sample is reversed, excess soil  
trimmed and sample sealed.

FIG. 38. Shallow sampling, cohesionless soil (sand). *Krymine, Soil Mechanics, McGraw-Hill Book Company.*



$L=12''$  For samplers less than 3" I.D.      Assembly  
 $L=16''$  For samplers 3" I.D. or greater

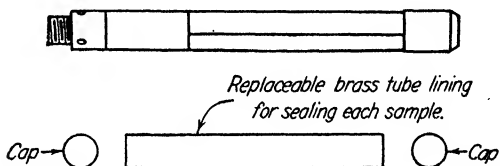

Moran and Proctor Sampler

FIG. 39. Deep sampler, cohesive soils.

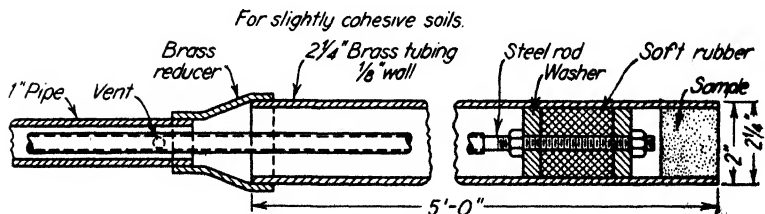

Fort Peck Sampler, U.S. Eng.

Note: A suggested sampler is the one used by Providence U.S.E.D., "Clay Sampler Type C" - consists of 4 1/4" diameter brass tube 1/16" thick plus a piston.

FIG. 40. Piston-type sampler, cohesive soils.

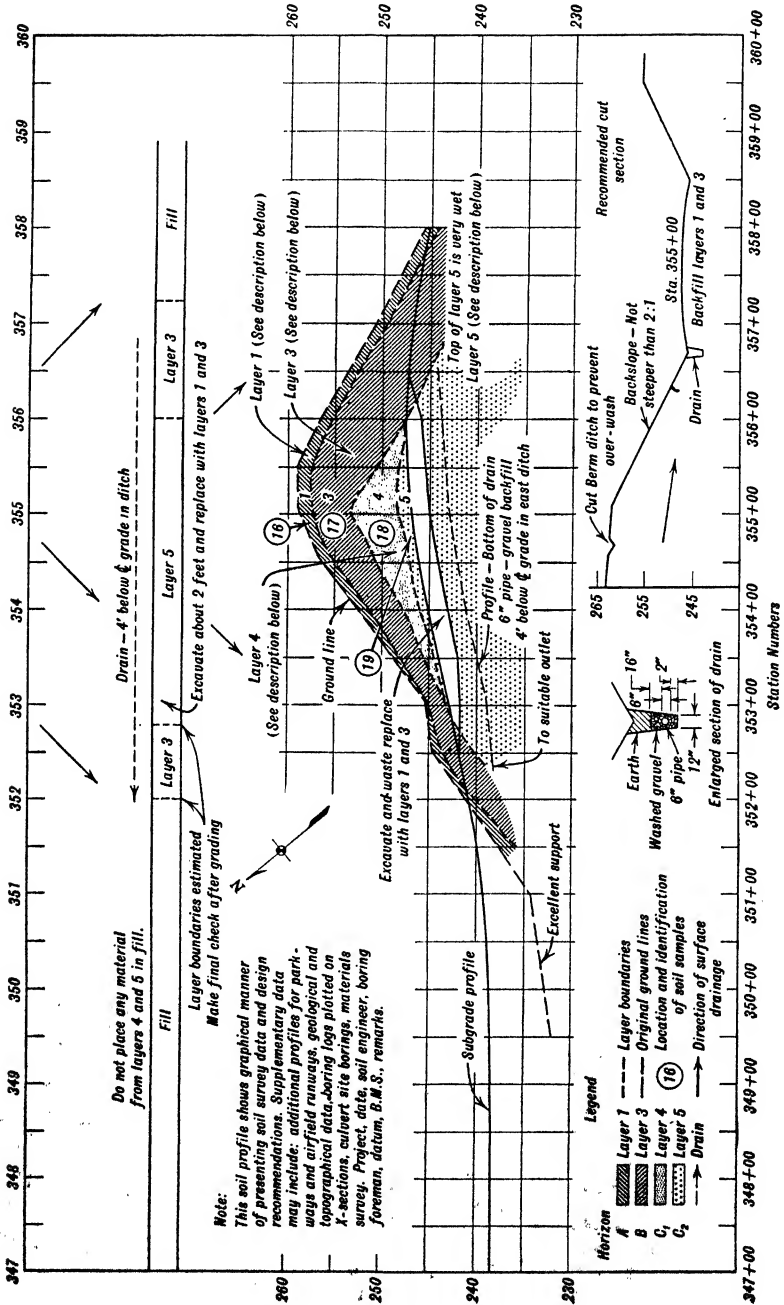

Results of Soil Tests

Identifi- cation Number	Layer	Mechanical Analysis							Plastic Index	Lower Liquid Limit	Shrinkage Ratio	Moisture Equivalent		Group	Textural Class	
		Per cent of particles having diameters smaller than										Field Juge	Centri- fuge			Group
		2 mm.	0.5 mm.	0.25 mm.	0.05 mm.	0.005 mm.	0.001 mm.	Group								
16	1	100	100	98	90	28	18									
17	3	100	98	96	85	19	14									
18	4	53	49	44	42	19	13									
19	5	100	98	96	99	73	50									
Physical properties of particles passing the 0.5 mm. sieve																
16	1	38	16	23	1.7	29	31								Silt loam	
17	3	27	18	18	1.7	36	22								Silty clay loam	
18	4	53	34	11	2.0	53*	33								Clay and gravel	
19	5	101	71	14	1.9	93 <sup>5</sup>	58								Plastic clay	

\* Waterlogged

Sample number 18 - Layer 4 contains coarse gravel. See description.

General Notes and Recommendations

- Drainage is across the road from east to west
- Original ground gives excellent support for fill
- Layers 1 and 3 are excellent subgrade materials
- Construct drain as shown on plan, profile, and cross section
- Cut and waste layer 5 material to a depth of about 2 feet below grade
- and backfill with layers 1 and 3. See plan, profile, and cross section
- Cut Berm ditch as shown in cross section
- Cut backlopes not steeper than 2:1
- Waste all material excavated from layers 4 and 5
- Pavement design should include longitudinal and transverse crack control

Description of Layers

Layer 1:  
Reddish brown mellow silt loam. Friable when dry but of  
pasty consistency when wet.

Layer 3:  
Grayish brown or mottled gray and rusty brown silty  
clay loam or silty clay of moderately compact structure.  
Compaction increases with depth. Friable when dry but  
plastic when wet. The compact nature of this layer does  
not seem to retard percolation to any degree.

Layer 4:  
Similar to layer 5 but contains a very large quantity  
of gravel varying in size from 1/4" to 2" with the largest  
percentage between 3/4" and 1 1/2". The presence of gravel  
apparently does not affect the structure particles or their  
behaviour. On drying, shrinkage cracks develop and soil  
shrinks away from gravel. This layer also includes a brown  
or grayish brown compact clay which is a transition between  
layers 3 and 5, and shrinks considerably on drying.

Layer 5:  
Mottled bluish gray and rusty brown plastic, sticky,  
and tenacious clay composed of angular structure particles  
which have a wet, shiny and slick surface. The particles  
are irregular in shape, easily crushed and when molded  
take on the appearance and consistency of putty. Upper  
3 feet of layer is very wet. It blends gradually into a  
dense, plastic, cloddy structured bluish gray clay which  
retards the downward movement of water but does not  
stop it, since the water can penetrate between the cleavage  
planes which are well defined. White concretions, black  
rusty brown and blood red stains are found throughout the  
layer. This material shrinks considerably on drying, leaving  
wide shrinkage cracks and an exposure the larger clods  
slake down to the smaller sized particles. This layer  
contains a high percentage of lime.

Fig. 41. Typical soil profile map as made for design and construction of road, runways, railroads, and canals. Adapted from *Surveying and Sampling Soils for Highway Subgrades, A.S.T.M.*

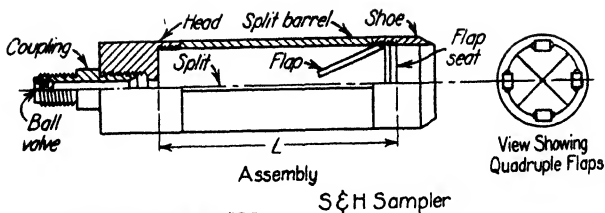

$L = 12"$  for less than 3" I.D.  
 $L = 16"$  for 3" I.D. or greater

*This sampler disturbs soil. Freezing and core drilling have been used with success for undisturbed samples.*

FIG. 42. Deep sampler, cohesionless soil. *Krymire, Soil Mechanics, McGraw-Hill Book Company.*

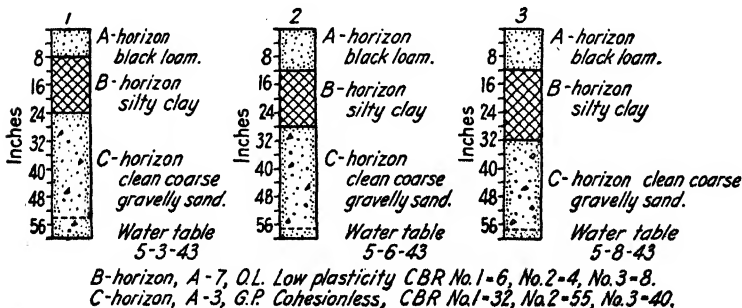
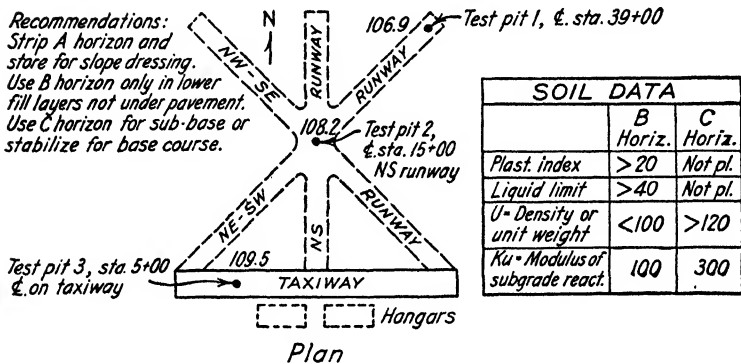

FIG. 43. Plan and log of test pits for airfield.

## BORING LOG † (TYPICAL STRUCTURES)

Location AntiguaStructure Hangar (See key plan) Sheet No. 1 of 2Boring No. 1 DatumBoring Inspector Smith Date 1-3-41

Stratification			Description of Materials (Type, Color, & Consistency)	Casing		Sample or Spoon		Sample No. *	Miscellaneous Data
Elevation	Depth	Legend		Blows	Penetration	Blows	Penetration		
73.7	0		Surface						Length of hole 26'-0"
			Brown sandy loam						Rock 5'-0"
			Trace of gravel			6	12"	1D	Weight of hammer 300 lbs
71.2	2'-6"								Aver. fall of hammer 30"
				8	12"	32	18"	2D	El. of ground water +68.4
			Fine brown sand	10	12"				Remarks**
66'	6W		Trace of gravel	16	12"				Few roots
				16	12"	28	12"	3D	Dry and friable
64.7	9'-0"								Fairly firm
			Firm, hard, yellow, silty clay.						Cohesionless
62.2	11'-6"			18	12"	20	18"	4D	Resistance
									increases with depth.
			Compact gravel, silt, and sand "hardpan"	380	12"	60	3"	5D	Becomes plastic when worked.
52.7	21'-0"								Chips of black slate embedded in silt.
			Buff-colored limestone.					6C	Casing and rods refused at 21'-0"
			Hard 80% core						Bottom of hole
47.7	26'-0"		recovery.						at 26'-0."

Note: Additional data may include: Key plan with contours, stations coordinates, and building outline; Benchmarks, date, drilling rig, casing dia.; length and diameter of sampler, Atterberg Limits, Mech. Analysis, density, water content.

\* Write sample number at corresponding depth, designate dry samples by D, wash samples by W, undisturbed samples by U, and rock cores by C.

\*\* When drilling cores in rock record the percentage of recovery in each foot of penetration.

FIG. 44.

† Caribbean Architect-Engineer.

## IDENTIFICATION OF PRINCIPAL TYPES

### TABLE 30. MAJOR DIVISIONS OF SOILS

Coarse-Grained (Granular)		Fine-Grained		Organic	
Gravel	Sand	Silt	Clay	Muck	Peat

### IDENTIFICATION—VISUAL AND BY TEXTURE

#### GRAVEL

Rounded or water-worn pebbles or bulk rock grains. No cohesion. No plasticity. Gritty and granular. Crunchy under foot. As a soil, over  $\frac{1}{10}$  in. in size. As an aggregate, over  $\frac{1}{4}$  in. in size.

#### SAND

Granular, gritty, loose grains, passing No. 10 and retained on No. 270 sieve. Individual grains readily seen and felt. No plasticity or cohesion. When dry, a cast formed in the hands will fall apart. When moist, a cast will crumble when touched. The coarse grains are rounded; the fine grains are visible and angular. As an aggregate for construction sand consists of mineral grains between  $\frac{1}{4}$  and  $\frac{1}{200}$  in.

#### SILT

Fine, barely visible grains, passing No. 270 sieve and over 0.005 mm. in size. Little or no plasticity. No cohesion. A dried cast is easily crushed in the hands. Permeable; movement of water through voids occurs easily and is visible. When mixed with water the grains will settle in from 30 minutes to 1 hour. Feels gritty when bitten. Will not form a ribbon. Care must be used to distinguish fine sand from silt and fine silt from clay.

#### CLAY

Invisible particles under 0.005 mm. (or 0.002 mm. in M.I.T. scale) in size. Cohesive. Highly plastic when moist. When pinched between the fingers will form a long, thin, flexible ribbon. Can be rolled into a thread to a pin point. When bitten with the teeth will not feel gritty. Will form hard lumps or clods when dry, difficult or impossible to crush in hands. Impermeable; no movement of water apparent through voids. Will remain suspended in water from 3 hours to indefinitely.

#### MUCK AND ORGANIC SILT

Thoroughly decomposed organic material with considerable mineral soil material. Usually black, with a few fibrous remains. Odorous when dried and burnt. Found as deposits in swamps, peat bogs, and muskeg. Easily identified. May contain some sand or silt.

PEAT

Partly decayed plant material. Mostly organic. Highly fibrous with visible plant remains.

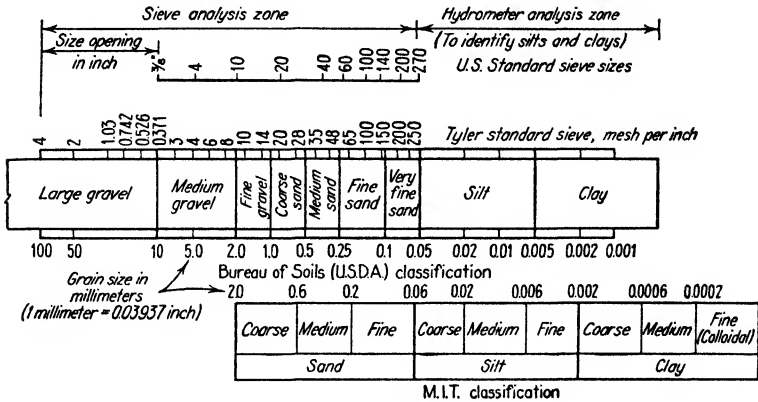

FIG. 45. Identification by mechanical grain size analyses.

Notes. Mechanical analysis is necessary to identify soils into the various divisions and into PRA and Casagrande systems. In general, the value of soils as a foundation for structures and as a material of construction is determined by the grain sizes and the gradation of the soil mixture. Other widely used grain-size classifications are International, M.I.T., Natl. Pk. Serv., A.S.T.M.

CLASSIFICATION OF SOILS BY HORIZONS

Soil Profile: A vertical cross section of the soil layers from the surface downwards.

The upper layer, surface soil or top soil. The upper part is designated A<sub>0</sub> and is humus or organic debris. Indices are used for subdivision into transition zones as shown for A<sub>1</sub>, A<sub>2</sub>, etc. May range to 24 in. in depth.

The heavier-textured underlayer or subsoil. May range from 6 in. to 8 ft. in depth. May be subdivided into transition zones B<sub>1</sub>, B<sub>2</sub>, etc., as shown. The products of the leaching or eluviation of the A horizon may be deposited in horizon B.

The unweathered or incompletely weathered parent material.

The underlying stratum such as hard rock, hard pan, sand, or clay.

Notes. Structures or pavements are not usually placed on A horizon soils. Also the organic content of these soils may adversely affect stabilization. In cuts the C horizon soil does not usually have as good bearing value as the more weathered B horizon. Foundations for heavy structures are preferably founded on the D horizon where it is bedrock or unyielding.

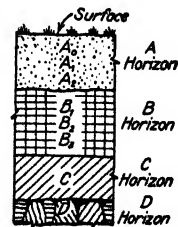

FIG. 46.



## P.R.A. CLASSIFICATION

TABLE 31. CHARACTERISTICS FOR IDENTIFYING P.R.A. SOIL GROUPS \*

Established by Public Roads Administration and Highway Research Board. Classification as shown is latest modification. Extensively used by engineers for highways, airfields, and dams.

Group	A-1		A-2		A-3	A-4 and A-4-7 †	A-5 and A-5-7 †	A-6	A-7	A-8
	Non-Plastic	Plastic	Non-Plastic	Plastic						
Textural Class	Uniformly Graded Granular Coarse to Fine		Poorly Graded Granular, Coarse, and Fine		Clean Sand or Gravel	Silt or Silt Loam	Silt or Silt Loam	Plastic Clay	Plastic Clay Loam	Muck and Peat
Internal friction	High	High	High	High	High	Variable	Variable	Low	Low	Low
Cohesion	High	High	Low	High	None	Variable	Low	High	High	Low
Shrinkage	Not detrimental		Not significant	Detrimental if poorly graded	Not significant	Variable	Variable	Detrimental	Detrimental	Detrimental
Expansion	None		None	Some	Slight	Variable	High	High	Detrimental	Detrimental
Capillarity	None		None	Some		Detrimental	High	High	High	Detrimental
Elasticity	None		None	Some	None	Variable	Detrimental	None	High	Detrimental
Capillary rise	Low	High	36" max.	Over 36"	6" max.	High	High	High	High	Detrimental
Liquid limit	25 max.	35 max.	35 max.	40 max.	Non-plastic	40 max.	Over 40	35 min.	35 min.	35-400
Plasticity index	6 max.	4-9	Non-plastic	15 max.	Non-plastic	0-15	0-60	18 min.	12 min.	0-60
Shrinkage limit	14-20		15-25	25 max.	Not essential	20-30	30-120	6-14	10-30	30-120

Soil Constants

Atterberg Limits

Field moisture equivalent	Not essential	Not essential	Not essential	Not essential	30 max.	30-120	50 max.	30-100	30-400
Centrifuge moisture equivalent	15 max.	12-25	25 max.	12 max.	Not essential	Not essential	Not essential	Not essential	Not essential
Shrinkage ratio	1.7-1.9	1.7-1.9	1.7-1.9	Not essential	1.5-1.7	0.7-1.5	1.7-2.0	1.7-2.0	0.3-1.4
Volume change	0-10	0-6	0-6	None	0-16	0-16	17 min.	17 min.	4-200
Lineal shrinkage	0-3	0-2	0-4	None	0-4	0-4	5 min.	5 min.	1-30
% Sand	70-85	55-80	55-80	75-100	55 max.	55 max.	55 max.	55 max.	55 max.
% Silt	10-20	0-45	0-45		High	Medium	Medium	Medium	Not significant
% Clay	5-10	0-45	0-45		Low	Low	30 min.	30 min.	
% Passing No. 10	20-100								
% Passing No. 40	10-70								
% Passing No. 200	3-25	Less than 35	Less than 35	0-10					
Grading (Grain Size)									

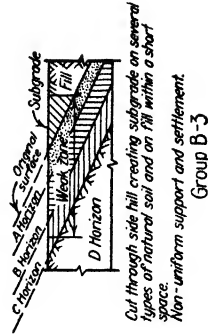

Cut through side hill creating subgrade on several types of natural soil and on fill within a short space.  
Non-uniform support and settlement.  
Group B-3

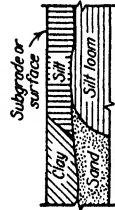

Adjacent parts of fill constructed of widely differing soil types, as where roadway is from different sources.  
Non-uniform support and settlement.  
Group B-2

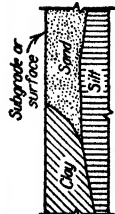

Rapid succession of soil types, pockets of different soil types. Changes in soil profile or changes in soil structure.  
Non-uniform support.  
Group B-1

Fig. 47. Classification of non-uniform subgrade soils.

\* Adapted from Public Roads Administration and Highway Research Board Publications.  
† A-4 or A-6 soil with A-7 characteristics.

## CLASSIFICATION

**TABLE 32. CLASSIFICATION OF SOIL MIXTURES \***

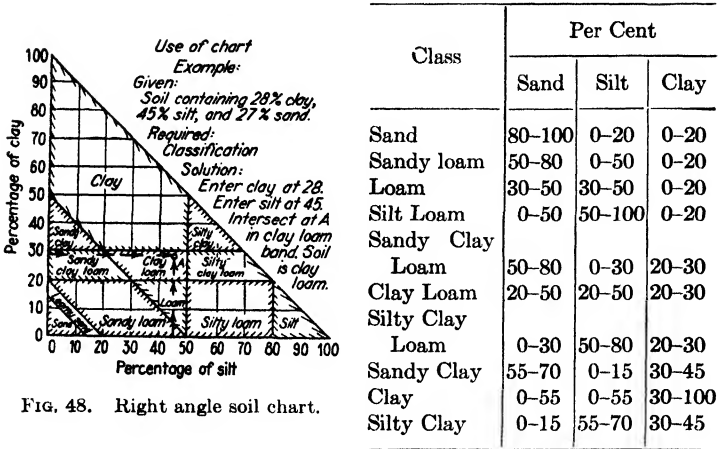

FIG. 48. Right angle soil chart.

\* Adapted from *Soil Cement Laboratory Handbook*, Portland Cement Assoc.

*Note.* Determine proportions of sand, silt and clay by sieve analysis or inspection.

(Natural soils seldom exist separately as gravel, sand, silt, clay, but are found as mixtures.)

**TABLE 33. CLASSIFICATION OF SOILS BY ORIGIN**

Residual:	Rock weathered in place—Wacke, laterite, podzols, residual sands, clays and gravels.												
Cumulose	Organic accumulations—peat, muck, swamp soils, muskeg, humus, bog soils.												
Transported	<table border="0" style="width: 100%;"> <tr> <td style="width: 15%; padding: 5px;">Glacial</td> <td style="padding: 5px;">Moraines, eskers, drumlins, kames—till, drift, boulder clay, glacial sands and gravels.</td> </tr> <tr> <td style="padding: 5px;">Alluvial</td> <td style="padding: 5px;">Flood planes, deltas, bars—sedimentary clays and silts, alluvial sands and gravels.</td> </tr> <tr> <td style="padding: 5px;">Aeolian</td> <td style="padding: 5px;">Wind-borne deposits—blow sands, dune sands, loess, adobe.</td> </tr> <tr> <td style="padding: 5px;">Colluvial</td> <td style="padding: 5px;">Gravity deposits—cliff debris, talus, avalanches, masses of rock waste.</td> </tr> <tr> <td style="padding: 5px;">Volcanic</td> <td style="padding: 5px;">Volcanic deposits—Dakota bentonite, volclay, volcanic ash, lava.</td> </tr> <tr> <td style="padding: 5px;">Fill</td> <td style="padding: 5px;">Man-made deposits—may range from waste and rubbish to carefully built embankments.</td> </tr> </table>	Glacial	Moraines, eskers, drumlins, kames—till, drift, boulder clay, glacial sands and gravels.	Alluvial	Flood planes, deltas, bars—sedimentary clays and silts, alluvial sands and gravels.	Aeolian	Wind-borne deposits—blow sands, dune sands, loess, adobe.	Colluvial	Gravity deposits—cliff debris, talus, avalanches, masses of rock waste.	Volcanic	Volcanic deposits—Dakota bentonite, volclay, volcanic ash, lava.	Fill	Man-made deposits—may range from waste and rubbish to carefully built embankments.
Glacial	Moraines, eskers, drumlins, kames—till, drift, boulder clay, glacial sands and gravels.												
Alluvial	Flood planes, deltas, bars—sedimentary clays and silts, alluvial sands and gravels.												
Aeolian	Wind-borne deposits—blow sands, dune sands, loess, adobe.												
Colluvial	Gravity deposits—cliff debris, talus, avalanches, masses of rock waste.												
Volcanic	Volcanic deposits—Dakota bentonite, volclay, volcanic ash, lava.												
Fill	Man-made deposits—may range from waste and rubbish to carefully built embankments.												

*Note.* In general, residual or glacial deposits are preferable for heavy foundations. Important in soil surveys and engineering reports.

## ATTERBERG LIMIT TESTS

**Purpose.** 1. To classify soils into P.R.A. or Casagrande Groups. 2. To assign soils a value as a foundation or construction material. 3. Construction control and laboratory reports. High values of L.L. and P.I. indicate high compressibility and low bearing capacity. High shrinkage values indicate excessive volume change.

The liquid limit (L.L.) of a soil is the water content at which the groove formed in a soil sample with a standard grooving tool will just meet when the dish is held in one hand and tapped lightly 10 blows with the heel of the other hand. In the machine method the L.L. is the water-content when the soil sample flows together for  $\frac{1}{2}$ " along the groove with 25 shakes of the machine at 2 drops per sec.

Diameter of brass cup or evaporating dish about  $4\frac{1}{2}$  in.

Size of sample: By hand 30 grams; by machine 100 grams.

Several trials are made, the moisture content being gradually increased. Blows are plotted against water content and the liquid limit is picked off from the curve as shown, or

$$\text{L.L.} = \frac{\text{Weight of water}}{\text{Weight of oven-dried soil}} \times 100$$

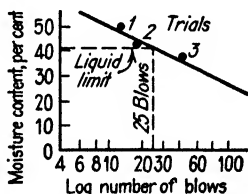

*Adapted from Krynine, Soil Mechanics, McGraw-Hill Book Company.*

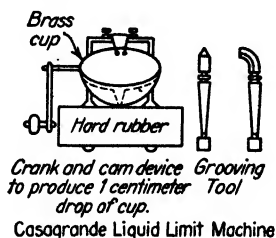

*Adapted from Hogentogler, Engineering Properties of Soil, McGraw-Hill Book Company.*

FIG. 49. Liquid limit (L.L.), A.S.T.M. 0423, A.A.S.H.O. T-89.

The plastic limit (P.L.) is the lowest water-content at which a thread of the soil can be just rolled to a diam. of  $\frac{1}{8}$  in. without cracking, crumbling, or breaking into pieces.

$$\text{P.L.} = \frac{\text{Weight of water}}{\text{Wt. of oven-dried soil}} \times 100$$

Size of soil sample is 15 grams.

Soil which cannot be rolled into a thread is recorded as non-plastic (N.P.).

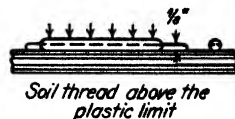

FIG. 50. Plastic limit (P.L.), A.S.T.M. D424, A.A.S.H.O. T-90.

**TABLE 34. LIMITING VALUES**

Base Course	Subgrade	Sub-base	Stab. Surf.	Soil Cement	Cem. Treated Base
No Shrinkage L.L. = 25 P.I. = 6 max.	Lineal Shrinkage 3% to 5%	L.L. = 35 P.I. = 15 max.	P.I. = 4 to 9	L.L. = 40 P.I. = 18 max.	L.L. = 25 P.I. = 6 to 9

The water content or moisture content is expressed as a percentage of the oven-dried weight of the soil sample. These soil constants are determined from the soil fraction passing the No. 40 (420-micron) sieve.

*Plasticity Index (P.I.):* A.A.S.H.O., T-91. Numerical difference between liquid limit (L.L.) and plastic limit (P.L.) or P.I. = L.L. - P.L. Example: Given L.L. = 28, P.L. = 24, P.I. = 4. Cohesionless soils are reported as non-plastic (N.P.). When plastic limit is equal to or greater than liquid limit the P.I. is reported as 0, see Table 31.

*Shrinkage Ratio (R):* = bulk specific gravity of the dried soil pat used in obtaining shrinkage limit.

$$R = \frac{\text{Weight of oven-dried soil pat in grams}}{\text{Volume of oven-dried soil pat in cc.}} \quad \text{or} \quad \frac{W_0}{V_0}$$

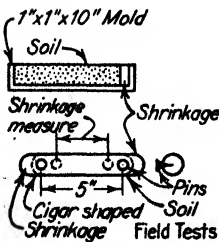
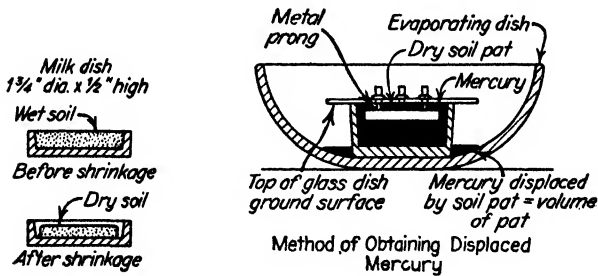

*Shrinkage Limit(s):* A.S.T.M., A.A.S.H.O., T-92. Water content at which there is no further decrease in volume with additional drying of the soil but at which an increase in water content will cause an increase in volume.

$$S = \left( \frac{1}{\text{Shrinkage ratio}} - \frac{1}{\text{Spec. gravity}} \right) \times 100.$$

Size of sample 30 grams.

*Lineal Shrinkage* is the decrease in one dimension of the soil mass when the water content is reduced to the shrinkage limit or the % change in length occurring when a moist sample has dried out.

**MOISTURE DETERMINATION**

**Purpose:** 1. To determine moisture content for optimum moisture and maximum density relations. 2. To determine the amount of water in aggregates for concrete, bituminous, and other mixtures.

*Gravelly soils:* Use pycnometer method, Fig. 51, or heat method described below.

*Sandy soils:* Use Chapman flask, Fig. 52, or heat method described below.

*Silts and clays:* Use heat method described below.

**Heat Method:** For total moisture content or surface moisture content.

1. Obtain a representative sample. If a metric scale is available the sample should not be smaller than 100 grams. If an avoirdupois scale graduated by  $\frac{1}{2}$  ounces is used, the sample should contain at least 50 ounces.

2. Weigh sample and record weight.

3. Place sample in pan and spread to permit uniform drying. Set pan in oven or on top of stove in a second pan to prevent burning of soil.

4. Dry to constant weight when total moisture is to be found; dry until surface moisture disappears when surface moisture content is desired. Temperature should not exceed 105° C. (221° F.). Stir constantly to prevent burning.

5. After the sample has been dried to constant weight, remove from oven and allow to cool sufficiently to permit absorption of hygroscopic moisture. Weigh dried sample and record weight.

6. Compute the moisture content as follows:

$$\text{Per cent moisture} = \frac{\text{weight of wet soil} - \text{weight of dry soil}}{\text{weight of dry soil}} \times 100$$

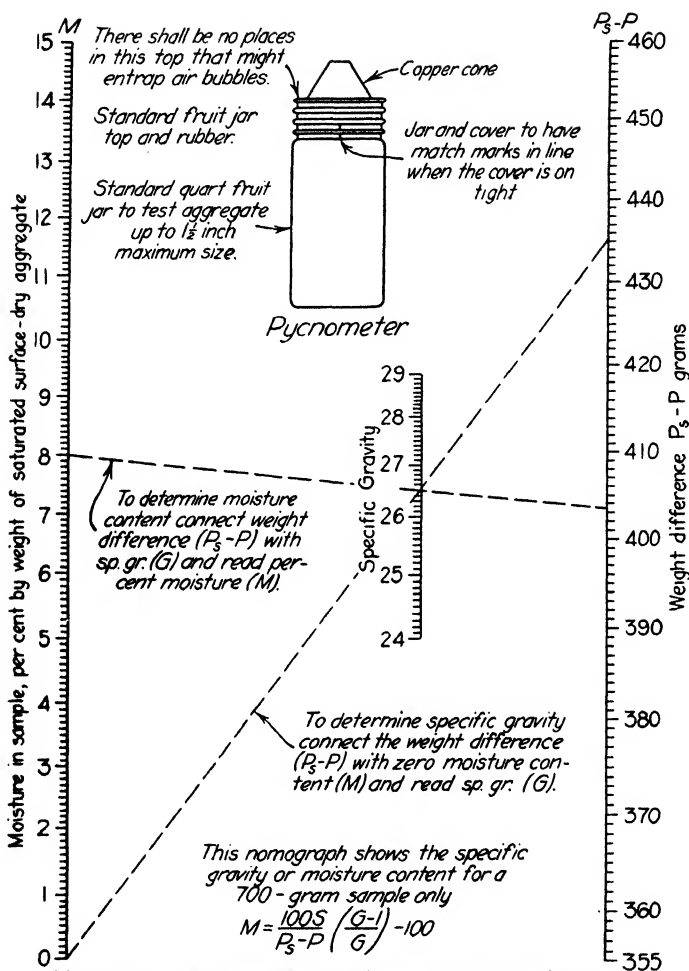

$M$ , moisture in sample, per cent by weight of saturated, surface-dry aggregate.

$S$ , weight of moist-sand sample = 700 grams for use with this nomograph.

$P$ , weight of the pycnometer full of water, grams.

$P_3$ , weight of the pycnometer containing the sample and filled with water, grams.

$G$ , specific gravity of the aggregate, saturated and surface-dry.

FIG. 51. Specific gravity and surface moisture content of aggregate, pycnometer method.

*Use of the Chapman Flask:*

Fill to the 200-ml. mark on the lower neck with water. Add 500 grams of moist soil and read the combined volume =  $V$  on upper scale.  $M$  = approximate percentage of surface moisture.

$$M = \frac{V - \frac{500}{\text{sp. gr.}} - 200}{200 + 500 - V} \times 100$$

Sp. gr. = the bulk specific gravity of the surface dry aggregate found by the equation  $500 \div (V' - 200)$ .

$V'$  differs from  $V$  in that 500 grams of dry sample is added instead of 500 grams of a moist sample as in the case of  $V$ . This method is only practical for the surface moisture of relatively sandy soils.

Use stirring rod to eliminate air.

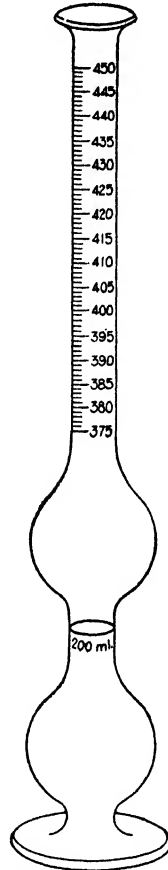

*Volume of lower chamber to mark on lower neck = 200 ml.*

*Combined volume of lower and upper chambers to lower end of graduated scale on upper neck = 375 ml.*

*Scale graduated in 1 ml. divisions from 375 ml. to 450 ml.*

*Diameter of opening in lower neck approximately 7/8 in.*

*Diameter of bore of graduated upper neck, approximately 3/4 in.*

Chapman Flask \*

*Note: Use with caution on account of absorbed air present.*

FIG. 52. Specific gravity and surface moisture content of aggregate, Chapman flask method.

**MAXIMUM DENSITY, OPTIMUM MOISTURE, PROCTOR NEEDLE PLASTICITY TEST**

**Purpose** of maximum density-optimum moisture test is to determine the percentage of moisture at which the maximum density can be obtained when soil is compacted in fill, earth dams, embankments, etc.

After the maximum density curve has been obtained, these samples may be subjected to the Proctor needle for resistance to penetration.

\* From A.S.T.M. Specifications.



Then subjecting soil at the site to the Proctor needle, the amount of compaction of soil at the site may be obtained. See Fig. 55(a).

**Maximum Density, Optimum Moisture, as per A.S.T.M.-D698-A.A.S.H.O.-D: T-99.**

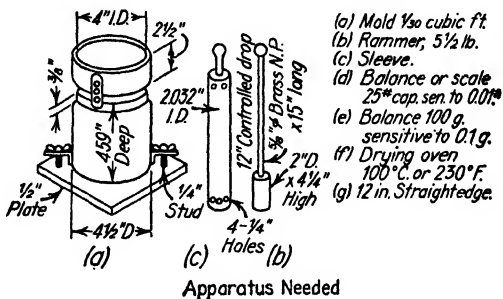

FIG. 53.

**Testing Procedure.** 6 lb.  $\pm$  (3000 grams) of air-dried soil slightly damp and passing the No. 4 sieve is mixed thoroughly, then compacted in the mold in 3 equal layers, each layer receiving 25 blows from the rammer with a controlled drop of 1 ft. The collar is removed, the soil struck off level and the mold weighed.

$$\begin{aligned} & (\text{Wt. of soil plus mold} - \text{wt. of mold}) \times 30 \\ & = \text{wet weight per cubic foot or wet density} \end{aligned}$$

A 100-g. sample from the center of the mold is weighed, then dried at 230° F., and the moisture content is determined.

Pulverize 6-lb. sample, add about 1% water, and repeat test. Repeat until soil becomes saturated (about 5 times). Plot wet-density curve. See Fig. 54. Compute dry density by formula and plot curve:

$$\text{Dry density} = \frac{\text{Wet wt., lb. per cu. ft.}}{\% \text{ moisture} + 100} \times 100$$

In Fig. 54 enter at top of dry density curve and read optimum moisture and maximum weight of soil 20.2% and 103.5 lb.

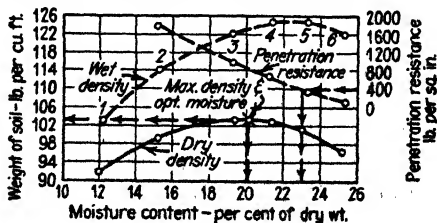

FIG. 54.

**Modified A.A.S.H.O. Method.\***

Same as above except:

1. Rammer to weigh 10 lb.
2. Rammer to have controlled drop of 18 in.
3. Soil compacted in mold in 5 equal layers, 25 blows to each layer.

The highest dry density is recorded as laboratory unit weight.

**Note.** Modern air field compaction equipment can secure greater densities than can be obtained by the standard Proctor or A.A.S.H.O. Test. If field compaction or vibration will give greater densities on any job than the test, the higher density should be used to control compaction.

**Proctor Needle Plasticity Test †**

Five pounds of dry soil passing a No. 10 sieve is mixed thoroughly with just enough water to make it slightly damp, then compacted in the mold in 3 layers. Each layer is given 25 blows with the rammer dropped 1 ft. The soil is then struck off level with the cylinder, weighed, and the stability determined with the plasticity needle by measuring the force required to press it into the soil at the rate of  $\frac{1}{2}$  in. per sec. A small portion of the soil is oven-dried to determine the moisture content. This procedure is repeated 3 to 6 or more times, each time adding about 1% more water until the soil becomes very wet. The density and plasticity needle readings are plotted against moisture content. See Fig. 54. Thus in Fig. 54 a needle reading of 400 gives a moisture content of 23%.

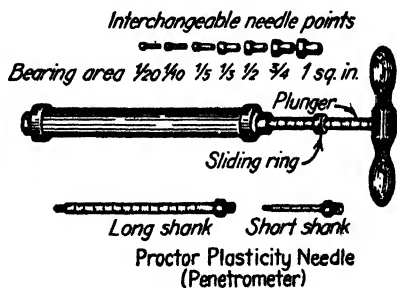

FIG. 55(a).

\* *Engineering Manual, O.C.E., War Dept.*

† *Engineering News-Record, Aug. 31 to Sept. 28, 1933, R. R. Proctor.*

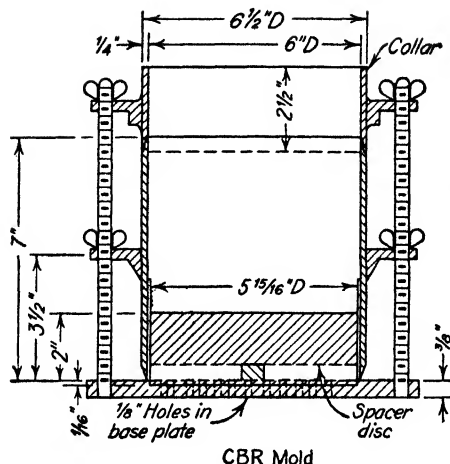

FIG. 55(b). Apparatus.

### California Bearing Ratio

**Purpose** is to obtain relative resistance of a soil in place or soil to be placed and compacted to a specified degree to a standard broken stone layer. The resistance of the standard layer is given in the last column of the report form for California bearing ratio on p. 130.

For soil in place apply a 3 sq in. end area piston at a constant rate of penetration of 0.05 in. per minute to a total penetration of 0.5 in. The penetration force required per square inch at the values in the left-hand column of the report form for California bearing ratio on p. 130 is recorded and stated as a ratio of the corresponding values in the right-hand column of the report; usually the values for 0.1-in. deflection are used.

Laboratory determination is made by remolding the samples of the soil until it has the specified density using the A.S.T.M. or A.A.S.H.O. methods given above, except that 55 blows of the rammer are used instead of 25 and material is passed through a  $\frac{3}{4}$ -in. sieve instead of a No. 4 sieve. These samples are then loaded by means of the same piston and recorded as given above for the field test.

For the purpose of determining the effect of saturating conditions on the soil, tests may be made on soaked samples.

### FIELD DENSITY (UNIT WEIGHT) TEST \*

**Purpose.** 1. To obtain the natural density of soil in place (a) as an indication of its stability or bearing value as foundation, (b) to compute

\* Adapted from *Public Roads*, Vol. 22, No. 12 by Harold Allen, Public Roads Administration.

the shrinkage or swell when the soil is removed and placed in embankment at a higher or lower density. 2. To determine the per cent of compaction being obtained to check against requirements of specifications.

### **Method of Determining Weight per Cubic Foot of Soil in Place. Calibrated Sand Method**

The density of a soil layer may be determined by finding the weight of a disturbed sample and measuring the volume of the space occupied by the sample prior to removal. This volume may be measured by filling the space with a weighed quantity of a medium of predetermined weight per unit volume. Sand, heavy lubricating oil, or water in a thin rubber sack may be used.

1. Determine the weight per cubic foot of the dry sand by filling a measure of known volume. The height and diameter of the measure should be approximately equal, and its volume should be not less than 0.1 cu. ft. The sand should be deposited in the measure by pouring through a funnel or from a measure with a funnel spout from a fixed height. The measure is filled until the sand overflows and the excess is struck off with a straightedge. The weight of the sand in the measure is determined, and the weight per cubic foot computed and recorded.

2. Remove all loose soil from an area large enough to place a box similar to the one shown in Fig. 57 and cut a plane surface for bedding the box firmly. A dish pan with a circular hole in the bottom may be used.

3. With a soil auger or other cutting tools bore a hole the full depth of the compacted lift.

4. Place in pans all soil removed, including any spillage caught in the box. Remove all loose particles from the hole with a small can or spoon. Extreme care should be taken not to lose any soil.

5. Weigh all soil taken from the hole, and record weight.

6. Mix sample thoroughly, and take sample for water determination.

7. Weigh a volume of sand in excess of that required to fill the test hole, and record weight.

8. Deposit sand in test hole by means of a funnel or from a measure as illustrated in Fig. 57 by exactly the same procedure as was used in the determination of unit weight of sand until the hole is filled almost flush with original ground surface. Bring the sand to the level of the base course by adding the last increments with a small can or trowel and testing with a straightedge.

9. Weigh remaining sand, and record weight.

10. Determine the moisture content of soil samples in percentage of dry weight of sample.

11. Compute dry density from the following formulas:

$$\text{Vol. soil} = \frac{\text{Wt. of sand to replace soil}}{\text{Wt. per cu. ft. of sand}}$$

$$\% \text{ moisture} = \frac{\text{Wt. of moist. soil} - \text{Wt. of dry soil}}{\text{Wt. of dry soil}} \times 100$$

$$\text{Moist density} = \frac{\text{Weight of soil}}{\text{Volume of soil}}$$

$$\text{Dry density} = \frac{\text{Moist density}}{1 + \frac{\% \text{ of moisture}}{100}}$$

$$\% \text{ compaction} = \frac{\text{Dry density}}{\text{Maximum density}} \times 100$$

EXAMPLE. Given:

Wt. per cubic foot of sand = 100 lb.

Wt. of moist soil from hole = 5.7 lb.

Moisture content of soil = 15%

Wt. of sand to fill hole = 4.5 lb.

Required: Density and per cent compaction.

Solution: Vol. soil =  $\frac{4.5}{100} = 0.045$  cu. ft.

Moist density =  $\frac{5.7}{0.045} = 126.7$  lb.

Dry density =  $\frac{126.7}{1 + 15/100} = 110.0$  lb.

Given maximum density = 115 lb. (from density test).

$\% \text{ compaction} = \frac{110}{115} \times 100 = 95.7\%$

Note. In gravel soils material over  $\frac{1}{4}$  in. is screened out and correction made.

*Chunk Sample Method.* 1. Cut sample 4"-5" in diameter full depth of layer. 2. Determine per cent moisture. 3. Trim sample and weigh to  $\frac{1}{2}$  oz. 4. Immerse sample in hot paraffin, remove, cool, and weigh again. 5. Compute volume of paraffin using 55 lb. per cu. ft. 6. Compute volume of sample by weighing in water (correcting for volume of paraffin). 7. Compute density data by formulas above.

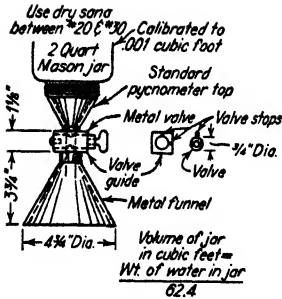

FIG. 56. Field density determination apparatus, dry sand method.

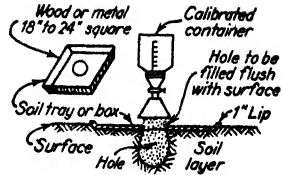

FIG. 57. Field density test.

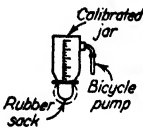

FIG. 58. Rubber sack inflated to fill hole with known volume of water.

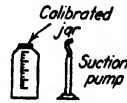

FIG. 59. Pump and jar to fill hole with known volume of oil. S.A.E.-40.

TABLE 35. BEARING VALUES AND PER CENT COMPACTION REQUIRED

Max. Dry Density	Soil Rating	Recommended Compaction
90 lb. and less	No good	
90 lb.-100 lb.	Very poor	95-100%
100-110 lb.	Poor to very poor	95-100%
110-120 lb.	Poor to fair	90-95%
120-130 lb.	Good	90-95%
130 lb. and over	Excellent	90-95%

Note. Density or  $\frac{Wt.}{Vol.}$  may be expressed as pound per cubic foot or grams per cubic centimeter. Density in grams per cubic centimeter = bulk specific gravity.

## MECHANICAL ANALYSIS (GRAIN SIZE)

**Purpose.** 1. To identify homogeneous soils in the major divisions. See pp. 108 and 109. 2. To classify soil mixtures occurring in a natural state, Table 32 & Fig. 46. 3. To classify soil into the P.R.A. or Casagrande groups. See pp. 110 and 111, also Vol. I, p. 3-06. 4. To design or control stabilized soil mixtures. 5. To determine frost heaving potentialities. 6. To determine effective size ( $D_{10}$ ) and uniformity coefficient ( $C_u$ ) for the design and control of filters and subdrainage backfill.

### Sieve Analysis

Size of sample to be 400 to 750 grams—the coarser the material the larger the sample required.

Take sample by quartering or with sample splitter.

MM.	No.	Inches	Equipment:
0.84	20	0.0331	Balance sensitive to 0.1 gram.
0.42	40	0.0165	Mortar and rubber-covered pestle.
0.25	60	0.0098	Sieves—See left. In addition it is desirable to have #4, #10, #20, and #40 for coarse-grain soil.
0.105	140	0.0041	
0.074	200	0.0029	
0.053	270	0.0021	

6" Frames, brass  
Sieves

Dry surface moisture by heating the quartered sample at less than 212° F., or boiling point of water at high altitudes, in open pan until surface water disappears and sample is apparently dry and will not lose more weight with additional heating.

Break up cakes with mortar and pestle.

Record dry weight of sample.

Proceed to pass material through screens by placing sample in a stack of sieves, largest size on top, and shake vigorously with horizontal rotating motion balancing on bumper or pad until no more material will pass through each screen.

Weigh amount retained on each sieve, compute per cent of total weight of sample, and plot curve.

Washing is recommended for No. 200 sieves and smaller.

Partly immerse the largest sieve in a pan of water and agitate.

Take material and water from pan and repeat for next smaller size sieve. Agitate smallest sieve in several water baths until water remains clear. Air-dry portions retained in sieves, weigh, and plot curve.

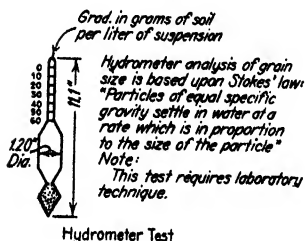

FIG. 60. Mechanical analysis of soils.

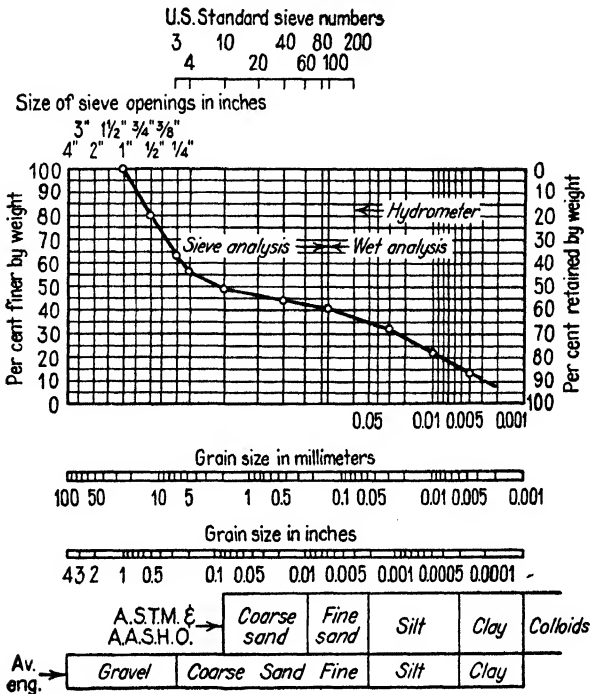

FIG. 61. Typical grain size curve.

**Effective size ( $D_{10}$ )** of a soil is the particle size that is coarser than 10% (by weight) of the soil; that is, 10% of the soil consists of particles smaller than the effective size ( $D_{10}$ ) and 90% consists of larger particles. *Example.* In Fig 62, effective size ( $D_{10}$ ) is 0.02 mm.

**Uniformity coefficient ( $C_u$ )** is computed by first determining the size that is coarser than 60% of the soil and dividing that size by the effective size ( $D_{10}$ ), i.e.,  $C_u = \frac{60\% \text{ size}}{10\% \text{ size}}$ .

*Example.* In chart,  $C_u = \frac{0.5}{0.02} = 25$ .

*Note.* The  $C_u$  of filter backfill should not be over 20. The  $D_{10}$  of non-frost heaving uniform soil is 0.02 mm. minimum.

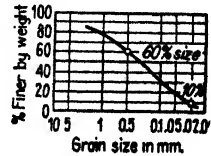

FIG. 62. Effective size ( $D_{10}$ ) and uniformity coefficient ( $C_u$ ).



---

 Engineer \_\_\_\_\_

## OPTIMUM MOISTURE—MAXIMUM DENSITY

## LABORATORY TEST

Location \_\_\_\_\_

Soil sampler \_\_\_\_\_

Date \_\_\_\_\_

Soil tester \_\_\_\_\_

Control soil # \_\_\_\_\_

Item	Run 1	Run 2	Run 3	Run 4	Run 5	Run 6
Weight of cylinder + wet soil						
Weight of cylinder						
Weight of wet soil						
Weight of wet sample + pan						
Weight of pan						
Weight of wet sample						
Weight of dry sample + pan						
Weight of pan						
Weight of dry sample						
Weight of moisture						
% of moisture						
Wet density						
Dry density						

Optimum moisture =

Maximum density =

---

 Engineer

## TUTTLE, SEELYE, PLACE &amp; RAYMOND

*Report on Density Determination*

Test No. _____	Date _____
Location _____	Depth _____
Soil sampler _____	Density of standard sand _____ lb. per sq. ft.

## FIELD TEST

Weight of sand and container	_____ lb.
Weight of sand and container (remaining)	_____ lb.
Weight of sand to fill hole and funnel	_____ lb.

Volume of field sample =

$$\frac{\text{weight of sand to fill hole and funnel}}{\text{density of standard sand}} - \text{volume of sand in funnel} \quad \text{_____ cu. ft.}$$

Weight of field sample (moist) and container	_____ lb.
Weight of container	_____ lb.
Weight of field sample (moist)	_____ lb.

## LABORATORY TEST

<i>Soil Tester</i>	<i>Date</i>
Weight of laboratory sample (moist) and container	_____ g.
Weight of container	_____ g.
Weight of laboratory sample (moist)	_____ g.
Weight of laboratory sample (dry) and container	_____ g.
Weight of container	_____ g.
Weight of laboratory sample (dry)	_____ g.
Weight of moisture in laboratory sample	_____ g.

$$\% \text{ moisture} = \frac{\text{weight of moisture in lab. sample}}{\text{weight of lab. sample (dry)}} \times 100 = \text{_____ } \%$$

$$\text{Field density} = \frac{\text{weight of field sample (moist)}}{\text{volume of field sample (1 + \% moisture)}} = \text{_____ lb. per cu. ft.}$$

$$\% \text{ compaction} = \frac{\text{field density}}{\text{maximum density}} \times 100 = \text{_____ } \%$$

Computed by \_\_\_\_\_ Checked by \_\_\_\_\_

---

 Engineer
 

---

## SOIL STUDIES \*

 Report for \_\_\_\_\_ Date \_\_\_\_\_  
 Material \_\_\_\_\_ Report No. \_\_\_\_\_  
 Project \_\_\_\_\_
 

---

Sample identification						Location of Samples		
Classification								
Hygroscopic moisture								
Gradation <i>Pass.</i> <i>Ret.</i> 1"            ¾" ¾"            ½" ½"            4 mesh 4              10 10             20 20             40 40             60 60             100 100            200 200 (wash)								
Hydrometer test % Finer #10 #200 0.005 mm. 0.001 mm.						Remarks:		
Liquid limit								
Plastic limit								
Plastic Index								
Specific gravity								
Absorption and Stability Tests of Materials Used	Opt. Mois.	Density Wt./cu. ft.	% Blended Soil	% Water	% Binder	7-day Absorp. %	7-day Stab. (lb.) Bottom ½-in.	

Inspector

\* From Haller Engineering Associates, Inc.

Engineer \_\_\_\_\_

SOILS CLASSIFICATION \*

Client \_\_\_\_\_ Date \_\_\_\_\_  
 Report No. \_\_\_\_\_

Site				
Sample No.				
Location				

SOIL TYPE

Size (mm.)	%	%	%	
Gravel 2.0 +				
Sand 2.0 - 0.05				
Silt 0.05 - 0.005				
Clay 0.005 -				

SIEVE ANALYSIS

Sieve Size	Diameter (mm.)	% Passing	% Passing	% Passing	% Passing
2"	50.80				
1½"					
1"	26.67				
¾"	18.85				
⅜"	9.423				
No. 4	4.699				
No. 10	1.981				
No. 40	0.417				
No. 60	0.248				
No. 100	0.147				
No. 200	0.074				

HYDROMETER ANALYSIS

Size of Particle	% Smaller than	% Smaller than	% Smaller than	% Smaller than
0.05 mm.				
0.005 mm.				
0.001 mm.				

Inspector \_\_\_\_\_

\* From Haller Engineering Associates, Inc.

---

 Engineer
 

---

## CALIFORNIA BEARING RATIO \*

 Client \_\_\_\_\_ Date \_\_\_\_\_  
 Report No. \_\_\_\_\_
 

---

Site \_\_\_\_\_

Sample No.				
Location				

## MAXIMUM DENSITY, OPTIMUM MOISTURE

Optimum water content (percentage of dry weight)				
Maximum density (pounds per cu. ft.)				

## CALIFORNIA BEARING TEST DATA

Condition of Sample							Standard
	Penetration (inches)	Lb. per Sq. In.	C/B Ratio	Lb. per Sq. In.	C/B Ratio	Lb. per Sq. In.	
0.025							
0.050							
0.075							
0.10							1000
0.20							1500
0.30							
0.40							
0.50							
Unit dry weight (pounds per cu. ft.)							
Expansion %							

## WATER CONTENTS—PERCENTAGE OF DRY WEIGHT

Unsoaked				
Soaked—Top 1 in.				
Soaked—Total				

---

 Inspector

\* Adopted from Haller Engineering Associates, Inc.

BORING LOG *									
Location _____			Structure _____		Sheet No. ___ of ___				
Boring No. ___		Datum _____		Boring inspector _____		Date _____			
Stratification			Description of Materials (Type, Color, and Consistency)	Casing		Sampler or Spoon		Sample No. †	Remarks ‡
Elevation	Depth	Legend		Blows	Penetration	Blows	Penetration		

† Write sample number at corresponding depth. Designate dry samples by *D*, wash samples by *W*, undisturbed samples by *U*, rock cores by *C*.

‡ When drilling cores in rock, record the percentage of recovery in each foot of penetration.

\* From Caribbean Architect-Engineer.

## BORING LOG (Continued)

Location of project \_\_\_\_\_

Location of boring \_\_\_\_\_

Coordinates \_\_\_\_\_ and \_\_\_\_\_

Drill No. \_\_\_\_\_

Boring foreman \_\_\_\_\_

Size and weight of casing \_\_\_\_\_ Depth \_\_\_\_\_

Length of hole \_\_\_\_\_ Earth \_\_\_\_\_ Rock \_\_\_\_\_

Type of rock drill used \_\_\_\_\_

Weight of hammer \_\_\_\_\_

Average fall of hammer \_\_\_\_\_

Elevation of ground water surface \_\_\_\_\_

## Record of Work

Date							
Start							
Finish							
Hours							
Total Depth							
Weather							
Temperature							

Boring inspector \_\_\_\_\_

Remarks \_\_\_\_\_

*Note.* Mark samples with name of base, name of structure, hole number, sample number, depth, and material.

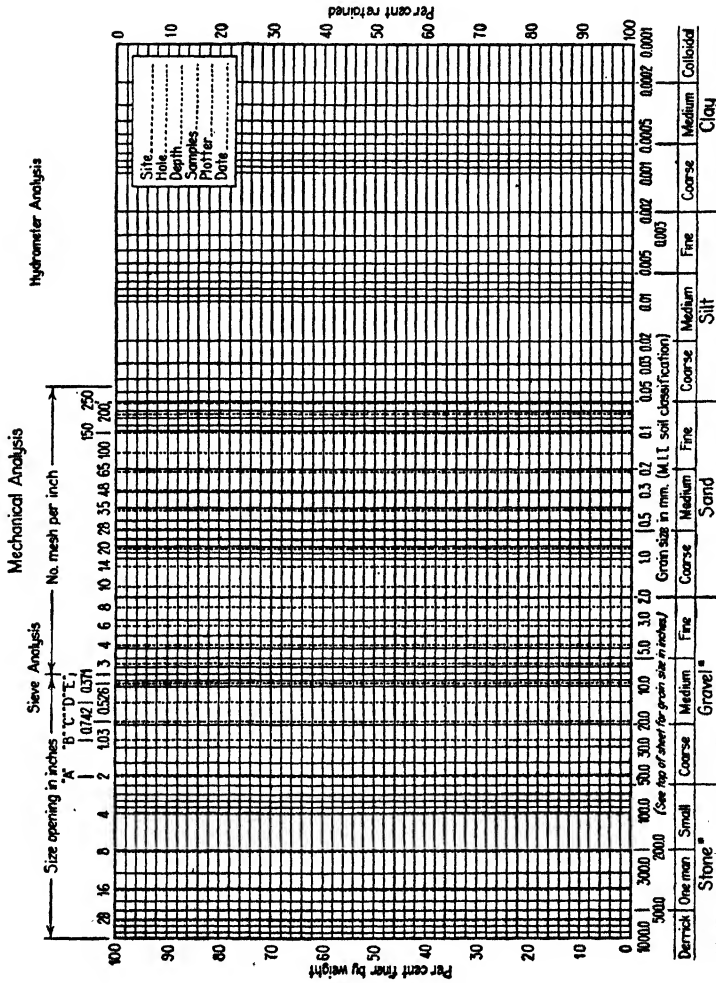

Purpose: to classify soil and to check conformance with specification

\* These sizes not included in original M.I.T. classification

From the Haller Engineering Associates, Inc.



# AGGREGATES

## FIELD TESTING

### Specific Gravity and Surface Moisture

Use fruit jar (see Fig. 51) and 2-kilo. (5-lb.) balance accurate to  $\frac{1}{10}$  gram.

**Specific Gravity.** Weigh jar full of water. Empty jar, place therein 700 grams surface-dry sample. Fill jar with water and weigh. Determine specific gravity from nomograph. See Fig. 51.

**Surface Moisture.** Same procedure except 700-gram sample is moist aggregate to be tested.

**Precautions.** Roll submerged sample to remove air. Jar must be dry outside when weighed. Use eye-dropper to insure completely filling with water. Remove foam.

**Surface Moisture, Heat Method.** Heat a weighed sample at 212° F., in open pan until surface water disappears (3 to 10 minutes). Weigh again. The difference between the original and the final weight is calculated as per cent of surface moisture.

**Total Moisture Content.** Heat weighed sample in open pan above 212° F. for 30 minutes or to constant weight. The difference between the original and the final weights is calculated as per cent of total moisture.

TABLE 36. APPROXIMATE SURFACE MOISTURE

(Use only when testing is impracticable)

CONDITION OF AGGREGATE	PER CENT BY WEIGHT
Very wet sand	6 to 8
Average stock pile sand, drained	3½ to 4
Moist sand	2
Moist gravel or crushed rock	2

### Tests of Gradation. Sieve Analysis, A.S.T.M. C-136

Quarter sample until sufficient material remains to give a dry sample as follows: sand under No. 10, 100 grams (0.2 lb.); sand under No. 4, 500 grams (1.1 lb.); coarse sand, 1000 grams (2.2 lb.); coarse aggregate under 1 in. maximum, 10 kg. (22 lb.); 2 in. maximum, 20 kg. (44 lb.); 3 in. maximum, 30 kg. (66 lb.). Use square- or round-aperture sieves as specified and of the sizes specified. If not specified, use square-mesh sieves as follows: bituminous aggregates, Nos. 200, 80, 40, 10, 4,  $\frac{3}{8}$  in.,  $\frac{1}{2}$  in.,  $\frac{3}{4}$  in., 1 in., 1½ in., 1½ in.; concrete aggregates, Nos. 100, 50, 30, 16, 8, 4,  $\frac{3}{8}$  in.,  $\frac{1}{2}$  in., 1½ in., 3 in. Use 8-in.-diameter sieves for samples of 5 kg. (11 lb.) or less and 16-in.-diameter sieves for larger samples. Use

balance or scale sensitive to 0.1% of sample weight. Set sieves in sequence with smallest size on bottom. Weighed sample is set on top sieve, and sieves are vibrated by lateral and vertical motion with jarring action. Weigh amount retained on each sieve and in pan, and compute percentage.

### Fineness Modulus

Add cumulative per cent retained on each of U. S. Standard Sieves listed above for concrete. Divide sum by 100; result equals fineness modulus.

### Material Finer than No. 200 Sieve—Silt and Clay in Fine Aggregate, A.S.T.M. C-117

Use two sieves, No. 200 and No. 16, and a vessel large enough to contain the sample covered with water, and permit agitation. Select a moist sample large enough to weigh 500 grams (1.1 lb.) when dry. The sample after being dried to constant weight is placed in the container and covered with water. The contents of the container are agitated vigorously and the wash water is poured over the nested sieves, the No. 16 being on top. The operation is repeated until the wash water is clear. The washed aggregate is dried to constant weight and weighed to nearest 0.02%.

% of minus No. 200 material

$$= \frac{\text{original dry weight} - \text{dry weight after washing}}{\text{original dry weight}} \times 100$$

### Approximate Amount of Silt and Clay

Place fine aggregate in a pint bottle to a height of 4 in.; then add water until the bottle is nearly full. Shake thoroughly, and allow to settle for 1 hr. or until the water is clear. Silt and clay will settle on top. The thickness of this layer should not be over  $\frac{1}{8}$  in. Alternative: Place 5 oz. of sand in 12-oz. graduated bottle and add water until the mixture equals 10 oz. after shaking. Allow to settle as above. If silt and clay content is more than 3% or as specified, sand should be washed or additional laboratory tests made.

### Organic Impurities in Fine Aggregate (Colorimetric Test), A.S.T.M. C-40

Fill a 12-oz. graduated prescription bottle to the  $4\frac{1}{2}$ -oz. mark with the sample to be tested. Add a 3% solution of caustic soda, known as sodium

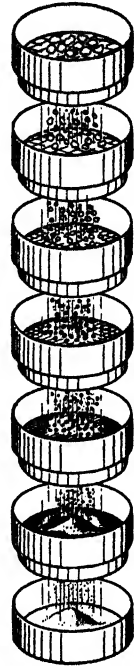

FIG. 63. Sieves.

hydroxide, until the volume of sand and solution after shaking reaches the 7-oz. mark. Let the bottle stand for 24 hr., then observe the color of the liquid above the sand. If colorless or light amber color, the sand may be considered satisfactory. If it is light brown or darker, the sand should be sent to laboratory for additional tests.

#### Unit Weight of Aggregate, Dry Rodded Method, A.S.T.M. C-29

Use a calibrated bucket of minimum No. 11 gage metal, a  $\frac{5}{8}$ -in. by 24-in. bullet-pointed tamping rod, and a scale accurate to 0.5%. The capacity of the bucket in cubic feet should be as follows:  $\frac{1}{2}$ -in. maximum aggregate size use  $\frac{1}{10}$  cu. ft.; 2-in. maximum aggregate size use  $\frac{1}{3}$  or  $\frac{1}{2}$  cu. ft.; 4-in. maximum aggregate size use 1 cu. ft. Aggregate should be room dry and thoroughly mixed. Fill the measure in 3 equal layers, rodding each layer 25 times. Strike off top layer and determine net weight. Calculate weight per cubic foot (unit weight). *Note.* In rodding use only enough force to penetrate the layer being rodded. The rod should not strike the bottom of the bucket.

#### Voids in Aggregate, A.S.T.M. C-30

$$\% \text{ of voids} = \frac{(\text{specific gravity of aggregate} \times 62.4) - \text{weight}}{(\text{specific gravity of aggregate} \times 62.4)} \times 100$$

where weight equals the weight in pounds per cubic foot of the aggregate as determined by the unit weight test above (A.S.T.M. C-29). Specific gravity is determined by nomograph, p. 116, or by laboratory.

#### Absorption of Aggregates

The following table may be used as a guide for the field where A.S.T.M. Tests C-127 and C-128 are not practicable.

TABLE 37. APPROXIMATE ABSORPTION OF WATER BY AGGREGATES

	PER CENT BY WEIGHT
Average sand	1.0
Calcareous pebbles and crushed limestone	1.0
Trap rock and granite	0.5
Porous sandstone	7.0

# SIEVE ANALYSIS REPORT

137

TUTTLE, SEELYE, PLACE AND RAYMOND  
ARCHITECT-ENGINEER  
FORT DIX NEW JERSEY

Contract No. _____	Date of test _____
Contractor _____	Type construction _____
Source of material _____	Plant _____
Sampled at _____	Used at station or building _____
Specification _____	Material _____

## REPORT ON AGGREGATES—SIEVE ANALYSIS

Screen or Sieve Size	Round or Square Shape	Weight Retained	Weight Passing	% Passing	% Spec. Reqmts.	
					<i>Min. Max.</i>	<b>WEIGHTS OF SAMPLE</b>
3"						Total weight _____
2½"						Dry weight _____
2¼"						Difference ___ % moisture
2"						After washing _____
1½"						% gravel (over ¼") _____
1¼"						Clay, etc. ___ % _____
1"						Material retained on _____
¾"						_____ Sieve _____ %
½"						Fineness modulus = sum cumulative % retained on each of Nos. 100, 50, 30, 16, 8, and 4, ¾-in., ¾-in., 1½-in., and 3-in. sizes + 100 =
⅜"						
¼"						
No. 4						
No. 8						Remarks:
No. 16						
No. 30						
No. 50						
No. 100						
No. 200						
Pan						

Remarks:

Tested by: \_\_\_\_\_

Approved \_\_\_\_\_

Disapproved \_\_\_\_\_

Inspector

Engineer

# GRADING

## CHECK LIST FOR INSPECTORS

### GRADING

#### Inspectors' Equipment

- Complete set of approved plans and specifications.
- Surveying instruments if required.
- 100-ft. tape and 6-ft. rule.
- Line level and line.
- Equipment for sampling and testing soils as required.

#### Procedure in Inspection

**Preparation of Site.** Check against specifications for:

- Stripping.
- Storage of topsoil.
- Removal of obstructions.
- Clearing and grubbing.
- Protection of trees.
- Removal of peat, muck, humus, sod.
- Removal or resetting of poles.
- Resetting or installation of culverts.
- Drains, sewers, water pipes, utilities.
- Cavities and trenches to be backfilled and tamped.
- Stake grades and slopes.
- Cross-section borrow pits.
- Cross-section rock as exposed before excavating.

**Selection of Material.** Follow specifications in selecting material such as placing granular material under paved areas.

- Broken rocks on slopes and in marshy foundations.
- Wasting peat, muck, frozen clods, organic matter.

**Soil Compaction.** Check specification requirements such as:

Weight of equipment and number of passes. Eight to twelve passes with sheepsfoot roller are customary. Three-wheel roller, 8 to 12 tons for final rolling of each layer and on the subgrade beneath base course. Caterpillar tractors may be used for granular soils when sheepsfoot or three-wheel rollers are not effective.

Thicknesses of layers rolled (usually 4 in. to 12 in.).

- Harrows, rotary tillers, reduction of moisture and soil mixture.
- Provision of water distribution in dry weather.
- Provision of uniform travel for construction equipment.

Do not permit end dumping over face of high fills.

Stable slopes may be obtained by filling beyond final grade and subsequently excavating to that grade.

Protection of pipes from injury by equipment during construction.

## BITUMINOUS PAVING FIELD SAMPLING

Material and Method	When Sampled	Size of Sample	Instructions
Asphalt, cement, crude asphalt, refined asphalt, bituminous materials, A.S.T.M. D-140	From each source in advance of work and from each carrier as delivered	1 qt. min. Asphalt emulsion or cut-back 2 qt. min.	Draw sample from top, bottom, and middle of tank by lowering bottle or can fitted with a stopper or lid lifted by attached wire, or sample may be taken from drain cock after initial draining. Solid or semi-solid asphalt sampled with clean hatchet or putty knife. Place liquids in small-mouth cans with cork-lined screw top. Place semi-solid material in friction lid cans. Ship crated or boxed. Mark cans.
Asphalt, A.S.T.M. D-290	Daily, for penetration test	3 oz. min.	Draw sample into can from valve over asphalt bucket on plant. Mix and pour into tin or glass container.
Asphalt sand, screenings, crushed stone and gravel, mineral fillers, A.S.T.M. D-75	Each source First shipment and if any change for laboratory tests Daily from piles or bins for plant tests	Fine aggregates 5 lb. min.; coarse aggregates 20 lb.	Quarter samples to size required. Sample from pits by channeling open face or from test hole. Sample from stock piles in various places avoiding base of pile. From cars, sample from top, middle, and bottom. Ship in strong, tight bags or boxes. At plant, sample separate sizes and composite mixture for daily sieve tests.
Heated and dried aggregates, A.S.T.M. D-290	Daily from bins	Fine, 5 lb.; coarse, 20 lb.	Pass shovel or pan quickly through stream of hot material as it flows from bin for daily sieve tests.
Bituminous mixtures (sheet asphalt, bituminous concrete, road mix, sand asphalt, plant mixes), A.A.S.H.O.T-41, A.S.T.M. D-290	Daily, or as specified or directed	Sheet asphalt, 1 lb. min.; bituminous concrete, 5 lb. min.; cold mixes, 15 lb. min.; compressed mixture, 6 to 12 in. sq. by full depth	At plant, take small portions from a number of batches during day, mix, and quarter to size. At paving site, composite sample from top, bottom, front, and back of load. Road mixes, shovel from course full depth, mix, and quarter. Ship samples in clean, tight box, carton, or friction lid can. Compressed samples, select location where mix is representative, before seal coat and after final rolling. Cut exact square to full depth of course.

### MARKING SAMPLES—ALL MATERIALS

**General.** Same as for concrete field sampling, p. 11.

**Bituminous Material.** Railroad car number, refinery, type, grade, proposed use.

**Aggregates.** Kind, source, where sampled, separated size or combined mixture.

**Bituminous Mixtures.** Type, plant, date, specified mix, station or location placed.

## FIELD OR PLANT TESTS

*May be used when full-scale laboratory tests are not practicable*

**Penetration of Asphalt (A.S.T.M. D-5)** is the distance, measured in units of  $\frac{1}{10}$  mm., that a standard blunt-point needle will penetrate a sample of asphalt at 77° F. when the needle is loaded with 100 grams applied for 5 seconds. Sample selected per p. 139, melted, stirred, and poured into container, 2.17 in. diameter by 1.38 in. Place in water for 1 hour at 77° F. to a depth of 4 in. and 2 in. off bottom of vessel. Sample is penetrated in at least 3 places, and average penetration is reported.

*Notes.* Sample must be maintained at 77° F. during the test by placing in a transfer dish filled with water and by returning the sample to the water bath after each test. The needle must be wiped after each test. Metal "ointment box" of above dimensions may be obtained at drug store. The inspector should have orders as to action to take if penetration is not as specified.

## NORMAL PENETRATION LIMITS

(77° F., 100 g., 5 sec.)

25-30	50-60	85-100
30-40	60-70	100-120
40-50	70-85	120-150
		150-200

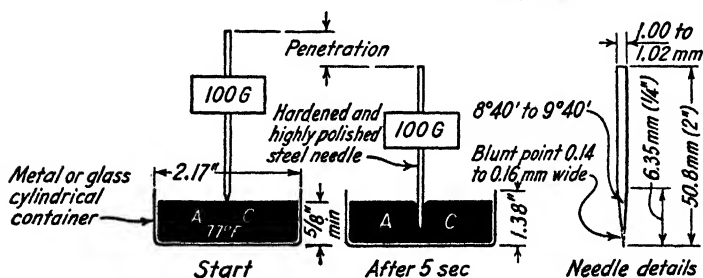

FIG. 64. Penetration test.

**Pat Test of Sheet Asphalt.** Select small sample of hot mix and note the temperature. Place at once upon a sheet of unglazed manila paper, resting upon a flat board. Fold the paper over the sample and press heavily with the flat of a wood paddle 6 in. long by 4 in. wide. Strike the paper a sharp blow with the paddle, open the paper, and remove the sample. If the stain is medium dark, bitumen content is about right. If it is very dark or sloppy, bitumen is excessive. If it is light and dry, bitumen is insufficient. If only the imprint of single sand grains appears, the amount of filler is deficient. If the space between sand grains is filled in, aggregate grading is good.

**Percentage of Bitumen and Mechanical Analysis of Mixtures.** The following method is for routine control where A.A.S.H.O. Tests T-58 and T-30 are not practicable. Dissolve and wash all the bitumen from a weighed sample of the mix with carbon tetrachloride, gasoline, or other solvent such as benzol, xylene, or chloroform, and weigh the recovered aggregate.

% of bitumen

$$= \frac{\text{weight of original sample} - \text{weight of recovered aggregate}}{\text{weight of original sample}} \times 100$$

*Note.* Wash aggregate clean. Avoid loss of any aggregate. If the percentage of bitumen varies from that specified, check the plant scales and the weighing operation. For sieve analysis of dried recovered aggregate (A.S.T.M. C-136 and C-117), see pp. 134 and 135, Aggregate Field Testing.

**Field Density of Compressed Mixture.** Immerse the weighed sample in hot paraffin, remove, cool, and weigh again. Weight gain is weight of paraffin. Volume of paraffin coat is calculated using 55 lb. per cu. ft. as weight of paraffin. Weigh the coated sample in water, record weight, and calculate the volume of the sample or measure the volume of the displaced water by an overflow device (weight water = 62.4 lb. per cu. ft.). Deduct the volume of the paraffin coat. Field density (lb. per cu. ft.) = net weight of sample in pounds ÷ volume of sample in cubic feet. The percentage of compaction = field density ÷ theoretical maximum density (from laboratory).

$$\% \text{ of voids} = \frac{\text{maximum density} - \text{field density}}{\text{maximum density}} \times 100$$

*Note.* Compaction to 94-96% of maximum density is usually specified.

## CHECK LIST FOR INSPECTORS

### BITUMINOUS PAVING—GENERAL

#### Inspectors' Equipment

Complete set of latest approved plans and specifications.

Penetrometer with extra needles and 3-oz. tins (optional; needed only when asphalt penetration is checked on job).

Supply of report forms, sample tags, cartons, cans, and sacks for shipping samples.

Metal dipper, pans, shovels, pails, etc., for sampling.

Armored thermometers of specified temperature range for both plant and field.



Set of screens or sieves of specified aggregate sizes.

Wire brush for cleaning sieves.

1 balance of 500-gram capacity.

1 scale or balance of 10- to 25-lb. capacity.

Supply of carbon tetrachloride or other solvent such as benzol, carbon disulfide, chloroform, or gasoline.

Putty knife for checking pavement depth.

6-ft. folding rule and 50-ft. steel tape.

10-ft. straightedge, 3-ft. straightedge, and template cut to required crown.

Grade line and string level.

Field books, pencils, keel or crayon.

Fruit jar, Chapman flask, or hot plate and pan for moisture content (not necessary for mixes with hot, dry aggregates).

### Procedure in Inspection

#### Bituminous Treatments

**Prime Coat.** Applied to receptive surfaces; should soak in.

**Subgrade or Base.** Compacted to specified density; should not shove, creep, or weave under a moving road roller.

Width, elevation, and cross section.

Condition to receive prime; excess loose material removed but surface not so tightly bound as to be impervious; slightly moist surface better for cutbacks and tars than dry and dusty; surface may be quite damp for asphalt emulsions.

**Application.** Bituminous material tested, approved, and of specified type.

Distributor truck calibrated and volume of material in load determined.

Distance each load should cover, at the width spread and at the gallonage per square yard specified, measured off and marked conspicuously. Amount of bitumen used is usually 0.20 to 0.45 gal. per sq. yd. for tight surfaces and 0.4 to 0.6 for open surfaces.

Distributor checked for specified requirements, usually: mechanical circulator, dual tires, pressure gage, range of application rates, positive shut-off, thermometer, spray bar width, measuring stick, tachometer, application pressure, wheel load or tire pressure, clean apertures or jets, load calibration and capacity.

Specified temperature of application adhered to.

Net gallonage computed by applying temperature conversion factor to gallonage measured at application temperature, see p. 158.

Provision to prevent overlap at beginning and end of application strip; usually building paper is laid down to insure a clear-cut joint.

**Cover Material.** May or may not be specified. If not specified, a light

cover in spots may be necessary to prevent migration of bitumen on steep grades and banked curves.

If specified, check following: gradation, type, moisture content, rate and uniformity of application, dragging, rolling, brooming and sweeping.

**Curing Period.** As specified, should elapse before subsequent applications or pavement courses.

**Tack Coat.** Usually applied to hard, dense impervious surfaces, without soaking in.

**Surface.** Cleaned or swept, dry but not dusty, patched, brought to line, grade and cross section as specified.

**Application.** Same as for prime coat except for following precautions:

As application is very light (0.08 to 0.15 gal. per sq. yd.) distributor must travel at very high speed; tachometer is a necessity.

All distributor bar apertures or jets must be open and functioning.

Uniformity can be obtained by use of burlap drag behind distributor.

Great care must be exercised to prevent overlapping at sides and ends of strips; resulting fat spots will seriously affect pavement.

Surface must be kept tacky or sticky till pavement is laid, not allowed to be covered with dust or dirt; traffic must be kept off.

**Seal Coat.** Surface. Prepared as per specifications.

**Application.** Same as for prime coat with same precautions as for tack coat except bitumen is usually immediately covered with aggregate. Leave an 8-in. strip of bitumen uncovered for lapping adjacent strips.

**Cover Material.** May or may not be specified. If specified, check type, gradation, moisture content, rate and uniformity of application.

Applied at once after bitumen is spread so particles can be embedded. Material should be spread out ahead in piles or windrows or spreader trucks should be on job before bitumen is applied.

Specified method of uniformly distributing cover material followed.

Rolling, if specified, began at once and continued until aggregate is embedded. Excessive rolling, causing crushing of particles, avoided.

Broom or wire mesh dragging carried on simultaneously with rolling unless otherwise specified.

Excess cover material swept off after rolling if specified.

Back spotting of bleeding areas with cover material for several days.

### **Mix-in-Place (Road Mix)**

**Subgrade or Base.** Compacted to specified requirements and shaped to correct width, grade and cross section.

**Prime Coat.** May or may not be specified. Same as for bituminous treatments.

**Aggregates for Mix.** Source approved and laboratory testing verified. Gradation checked before use and continuously during operations.

Aggregate may be bank run or artificially mixed as specified; in either

case the aggregate, before mixing with bitumen, should conform to specified gradation.

Continuous check on any special requirements such as liquid limit, plasticity index, percentage of silt and clay, either by sending samples to laboratory or by field testing as directed by superiors.

Preparation of Aggregate. Loose aggregate spread flat or in windrows in such volume and to such depth as to produce specified thickness when compacted.

Coarse or fine material mixed into aggregates to produce specified gradation if necessary.

Mixed aggregate brought to specified moisture content by pulverizing and aeration if wet or by sprinkling if dry. If not specified otherwise, usually maximum 2% moisture for cutback asphalts and tars, and 4 to 5% moisture for emulsions. Sprinkling necessary only when aggregate is very dry and dusty.

As contractor will demand quick moisture readings, use of fruit jar pycnometer is recommended; see p. 134.

Application of Bituminous Material. (a) By Set Quantity per Square Yard. Same as for bituminous treatments, prime coat. Follow job specification for increments and sequence of application. If not specified, best practice is to apply in increments of 0.5 to 0.6 gal. per sq. yd. with partial mixing between increments. For dense graded mixes, 0.5 to 0.6 gal. per sq. yd. per inch of depth of finished mix should suffice.

(b) Quantity Varied per Aggregate Gradation. Inspector must make continual screen analysis and compute required quantity of bitumen by formula or method as specified or directed. Screen analysis made either at pit, plant, or on the site, preferably on the site. Bitumen usually 4 to 7% by weight.

Mixing. (a) By Blade Graders. Graders to cut clear down to base (but not to cut into or tear up the base) and make complete turnover. Mixture to roll over in front of grader blade. Mixing to begin at once behind bituminous application to prevent migration of bitumen. Graders to manipulate mixture back and forth across entire width of road or strip being placed. Mix in as long strips as possible keeping turnarounds to minimum. Mixing to continue until all aggregate particles are coated; usually 12 to 15 complete turnovers are necessary.

Areas deficient in bitumen, i.e., dry, brownish color, powdery, no cohesion, large particles uncoated, should receive additional bitumen and remixing.

Areas with excess bitumen, i.e., greasy, fat, sloppy, unstable, free bitumen in evidence, corrected by adding more aggregate and remixing.

(b) By Rotary Tillers (Pulvi-Mixers, Roto-Tillers, etc.). Same general procedure as for blade graders except:

Aggregate is usually spread flat and mixed flat.

Aggregate is not manipulated back and forth.

Bitumen applied in 0.4 to 0.6 gal. per sq. yd. increments with partial mixing between applications is best practice.

Watch for balling up of aggregate, i.e., lumps of uncoated aggregates.

If road or area is wide enough, transverse, diagonal or figure-8 travel of the Rotary-Tiller is recommended.

Mixing continued till all aggregates are coated for full depth.

*Note.* Rotary tillers and blade graders are sometimes operated in combination. Blade grader throws up windrow directly in front of rotary tiller, which mixes and spreads out flat; 10 to 12 repetitions of this process will usually produce uniform mixture.

(c) By Travel Plant Methods. Check calibration of measuring devices on machine.

Control of moisture content of aggregates by constant checking.

Gradation of material in windrows; continual screen analysis.

Accurate windrowing of aggregates ahead of travel plant to produce required finished thickness and width of pavement.

Mixed material as it leaves plant to have all aggregates coated, well mixed, and uniform in gradation and bitumen content.

Bituminous material introduced within specified temperature range.

Mixture may be spread with blade graders or paving machine; follow job specifications.

Curing. As specified.

Rolling. Equipment and methods as specified, to continue until mix is compacted to specified density, is smooth, and shaped to specified cross section and elevations.

Seal Coat. Same as for Bituminous Treatments.

### **Penetration Macadam**

Subgrade or Base. Compacted to specified requirements and shaped to correct width, grade, and cross section.

Aggregates. Coarse stone, choke stone, and chips tested and approved for gradation and quality before use.

Inspection of gradation primarily visual, but screen analysis should be made once a day.

Avoid an excess of stone under 1¼-in. size, dust, and screenings, which will form mats that bitumen cannot penetrate.

Placing Aggregates. May be spread by hand, spreader boxes, machines, or blade graders.

Avoid segregation of coarse and fine stone.

Spread in layers as specified; 3½ in. to 4 in. is about the maximum thickness one layer can be built.

Depressions removed by working coarse stone into low areas; do not fill depressions with fine stone.

Pockets or areas of fine stone or choked with dust removed and replaced with properly graded stone.

Surface true, "spotted" to grade and cross section and without areas of excess fine or coarse stone before rolling begins.

**Initial Rolling.** Begin at sides and progress to center, overlapping shoulder and each previous wheel mark.

Rolling to continue until all stone keyed together.

Depressions developing during rolling corrected.

Rolling not to continue if stones are being crushed. Check stone soundness; if okay, add keystone or use lighter roller. (Some emulsified asphalt specifications require keystone to be spread during initial rolling; check.)

Roll in as long strips as possible to avoid reversing roller.

Rollers to operate in straight, not wavy, lines, and reverse motion smoothly, not in jerks.

Bituminous Application. Do not begin until surface is dry (except for emulsions), not dusty or excessively choked, and uniformly compacted.

Application is same as for prime coat, Bituminous Treatments.

Choke Stone (applied after bituminous material). Spread uniformly, just sufficient to fill voids in stone.

Rolled and broom dragged simultaneously until surface is thoroughly consolidated and free from large voids.

In hot weather or with asphalt emulsions this rolling and brooming may be postponed until day following bituminous application.

Continue rolling and broom dragging until all roller creases and marks are removed and surface does not creep or shove under roller wheels. Additional small amounts of keystone may be added during this process.

*Note.* Follow job specifications for quantity of bitumen and increments of application. Practice varies from applying bitumen in one heavy application with one choking and rolling to applying bitumen in two or three increments with choking and rolling after each.

Seal Coat. Same as for seal coat, Bituminous Treatments.

Pay Items. Accurate record of all pay items in contract.

Gallons of bituminous material placed (corrected for temperature).

Tons, square yards, or cubic yards of aggregates or completed pavement as specified.

Extra applications of bitumen and aggregates.

## CHECK LIST FOR INSPECTORS

### PLANT-MIX BITUMINOUS PAVING

#### Procedure in Inspection

#### Plant Inspection

**Tested and Approved Materials.** Bituminous material, aggregates, and fillers tested and approved before use.

Samples of aggregates, bitumen, and mixture shipped to laboratory at least once a week.

Daily screen analysis of aggregates and completed mixture.

**Storage and Handling of Materials.** Aggregates stock piled to avoid segregation and intermingling.

Mineral filler stored in dry place.

**Plant.** Plant equipment to meet specifications.

Weighing devices to work properly. Check scales with standard weights.

Tare weight of asphalt bucket checked twice daily. Tare weight is weight of empty bucket including residue and adhering bitumen.

Bucket kept clean or correction made for adhering bitumen.

Weigh box large enough to prevent spilling, with tight gates and in good condition.

No segregation or intermingling of aggregates before mixing.

Screens of specified size to completely separate various sizes required.

Asphalt thermometers checked for correct reading.

Weighing facilities for mineral fillers.

Correction of aggregate grading if variation occurs.

Scales for aggregate and bitumen set to produce specified mixture.

No change in basic mix proportions without approval from engineer.

**Mixing Operations.** Specified moisture content of aggregates adhered to for cold aggregate mixes.

All aggregates coated with bitumen and mix of uniform color and consistency.

Bitumen bucket completely emptied or drained.

Mixing time as specified and sufficient to coat aggregate thoroughly.

On sheet-asphalt jobs sand gradation checked hourly.

Weekly check of aggregate scales or more often if variation occurs.

Net weight of truck loads to equal total batch weights; check once a week.

Aggregates and bitumen heated to specified or approved temperatures; keep daily record.

Aggregates or bitumen never to be heated above the specified limits.

Mixture leaves plant at specified or approved temperature.

Proportions of mixture checked daily by dissolving the bitumen of a representative sample and making screen analysis of aggregates.

**Transporting Mixture.** All trucks covered with canvas or tarpaulin.

Trucks cleaned and sprayed with light oil or soap emulsion before mixture is placed therein; avoid excess.

Insulated truck bodies preferable if available.

No loads sent out if weather will hinder proper laying; cooperate with field inspector and contractor in this respect.

### **Field Inspection**

**Subgrade or Base.** Compacted and shaped according to plans and specifications.

Prime or tack coats, if specified, properly applied and curing time elapsed.

Holes and depressions repaired and rolled in advance of paving.

Base dry before mix is placed.

*Note.* Proper compaction and contour of base and subgrade are essential to a smooth and satisfactory pavement.

**Forms.** If specified, must be rigidly supported and accurately set to line and grade.

**Placing.** Paving machines and rollers inspected and approved before use for conformance with specified requirements.

Screeds on paver checked for crown ordinates. See p. 229 for crown offsets.

Screeds cleaned at noon and night shutdowns with fuel oil and scrapers.

Contact surfaces of paving equipment lightly oiled.

Avoid excessive hand raking behind paver. Paver should be so adjusted that only occasional touching behind will be necessary by hand.

Notify plant to shut down if rain begins. Loads in transit are customarily allowed to be placed if they are covered and temperature is sufficiently high.

Mixture delivered at proper temperature and not too rich or too lean.

*Note.* Excessive bitumen in mix will flush to surface during rolling and mix will be fat, greasy, and soupy. Deficient bitumen is indicated by cracking under roller, pushing into lumps, and dull, lusterless appearance. Either condition must be reported immediately to plant inspector.

Check temperature frequently by use of immersion armored thermometer of Weston type or equal.

An overheated or burnt-up batch will usually give off a cloud of acrid, white smoke when dumped.

If bitumen drains off or migrates to bottom of truck and aggregate on top is uncoated, the plant inspector should be notified immediately.

Check thickness of course as follows: (1) Compute number of square yards a load will cover, and make a mark on the base to which a load should spread. (2) After initial rolling make small hole with putty knife in mixture and check depth with rule. (3) Check square yards laid against tons hauled at noon and at end of day. For dense bituminous concrete mixes, the yield should be about 1 sq. yd. for 1 in. in depth for every 110 lb. of mix.

Mixture spread to a loose depth that will produce specified finished thickness; loose depth must be determined by experiment.

**Hand Spreading.** Each shovelful turned over as placed and load so dumped that entire batch is shoveled into place.

Workmen not to walk in loose mixture.

Avoid excessive raking that pulls coarse stone to surface.

Control depth with spreading blocks of correct height.

Shovels, rakes, and tampers kept hot and clean.

**Rolling.** Rollers of type and weight specified, and equipped with water spray and scrapers on wheels.

Begin rolling as soon after spreading as mixture will bear the roller without shoving or hair cracking.

When specified, check square yards rolled per hour per roller.

Begin rolling at sides and proceed toward center, overlapping one-half width of roller on successive passes.

If not specified otherwise, use tandem rollers for initial rolling and keep 3-wheel rollers off until mix is somewhat cooled.

Rollers to reverse motion smoothly, not in jerks.

Length of roller passes to be staggered.

Surface checked immediately after initial rolling with straightedge and template. This must be done before mix cools so corrections can be made. Tolerance usually  $\frac{1}{8}$  in. to  $\frac{1}{4}$  in. in 10 ft. Try to correct surface before mix hardens to avoid unsightly skin patches later.

Rollers and trucks not to park on pavement while it is still plastic.

Excessive rolling avoided; it will cause crushing of aggregate and displacement of mix.

Rolling diagonally and at right angles very desirable if width of street or road is sufficient.

Rolling continued until all roller creases are removed and specified density is attained.

**Joints.** At shutdowns and end of day's work, transverse joints are formed by rolling over edge and then cutting back a vertical joint at full depth.

All cold joints painted with liquid bitumen and fresh mixture rolled firmly against the joint face.

**Seal Coat.** If specified, check gallons per square yard, temperature, and type of material.

**Final Inspection.** Depressions and bumps over specified tolerance corrected by concentrated rolling or skin patches.

Oil spots and fat spots cut out and refilled and tamped.

Disintegrated spots where mixture is raveling cut out to full depth with vertical faces and refilled with fresh mixture thoroughly tamped and rolled.

**Opening to Traffic.** Edges protected from traffic runover before opening pavement, usually after final rolling when mix has cooled off and hardened or from 4 to 12 hr. after placing.

**Pay Items.** Accurate record kept of all contract pay items, such as:

Tons, square yards, or cubic yards (as specified) of mixture laid.

Volume of embedded structures if deducted from unit price.

Gallons or square yards of any prime, tack, or seal coats applied.

Record of batches condemned or wasted.

Any other contract pay items.



TABLE 38. USE OF BITUMINOUS MATERIALS

MATERIAL	ROAD TAR (RT)												ROAD OIL, SLOW CURING ASPHALTIC (SC)									
	CUTBACK ROAD TAR (RTCB)						ROAD TAR (RT)						ROAD OIL, SLOW CURING ASPHALTIC (SC)									
Commercial grade	RT-1	RT-2	RT-3	RT-4	RT-5	RT-6	RT-7	RT-8	RT-9	RT-10	RT-11	RT-12	RTCB-5	RTCB-6	SC-0	SC-1	SC-2	SC-3	SC-4	SC-5	SC-6	
Application temperature, °F	60	125	80	80	150	80	150	225	150	175	250	175	250	60	120	120	120	160	250	175	225	400
Penetration macadam, hot																						
Penetration macadam, cold																						
Plant-mix, open-graded mixes																						
Mix-in-place, open graded (crushed stone)																						
Plant-mix, dense-graded mixes																						
Mix-in-place, dense-graded mixes (gravel mulch)																						
Bituminous concrete																						
Surfaces treatment																						
Seal coats (fog, flush, or sand cover)																						
Seal coats (carpet, stone, or armor coat)																						
Track coats																						
Prime coats (dense or tight bases)																						
Prime coats (porous or open bases)																						
Soil stabilization																						
Dust palliative																						
Patching mixtures (cold patch)																						
Seed mix																						
plant mix																						
road mix																						
Crack and joint filler																						

\* Cool weather work (spring and fall). † Hot weather work (summer).

Note. For both tars and road oils, the higher the number the more viscous the material. Thus an RT-1, RT-2, and SC-0 are non-viscous liquids at ordinary temperatures suited for soaking into a highly bound base like clay-gravel. RT-4 to RT-7 and SC-2 to SC-4 will remain semi-liquid and are suited for mixing in place. RT-10 to RT-12 and SC-5 or SC-6 become solid or semi-solid at air temperatures and are suited for hot plant mixes, sealing, and macadam.

References. F. R. A., Koppers Co., Barrett Co., A.S.C.E., Barber-Greene Co.

TABLE 38. USE OF BITUMINOUS MATERIALS, Continued

MATERIAL	MEDIUM CURING CUTBACK ASPHALT (MC)					RAPID-CURING CUTBACK ASPHALT (RC)					ASPHALT EMULSION (AE)					ASPHALT CEMENT (AC) PENETRATION								
	MC-0	MC-1	MC-2	MC-3	MC-4	MC-5	RC-0	RC-1	RC-2	RC-3	RC-4	RC-5	RS-1 & 2	MS-1	MS-2 & 3	HS-1	275	350	45	70	85	150	200	
Commercial grade																								
Application Temperature, °F.	150	175	200	225	250	275	60	125	150	175	200	225	250	120	120	120	135	275	350	45	70	85	150	200
Penetration macadam hot																								
Plant-mix, open-graded																								
Mix-in-place, open-graded (crushed stone)																								
Plant-mix, dense-graded																								
Mix-in-place, dense-graded (mulch)																								
Bituminous (asphaltic) concrete																								
Sheet asphalt																								
Sand asphalt plant-mix																								
Sand asphalt mix-in-place (road mix)																								
Surface treatment																								
Seal coats (fog, flush, or sand cover)																								
Seal coats (carpet, stone, or armor coat)																								
Track coats																								
Prime coats, dense or tight bases																								
Prime coats, open or porous bases																								
Soil stabilization																								
Dust palliative																								
Patch mixtures (cold patch)																								
Joint filler, brick																								
Crack and joint filler																								

\* Cool weather work (spring and fall). † Hot weather work (summer).

Note. For cutback asphalts, the higher the number the more viscous the material. For asphalt cements, the higher the penetration number the softer the asphalt; thus for heavy traffic in hot weather a stiff grade such as 45 to 70 or 70 to 85 is used and for cool weather or light traffic softer grades are used. For asphalt emulsions, SS = slow setting; MS = medium setting; RS = rapid setting.

References. F.R.A., Asphalt Institute, A.S.C.F., Barber-Greene Co., Texas Co.

## BITUMINOUS PAVING

TABLE 39. GALLONS ASPHALTIC MATERIALS REQUIRED AT VARIOUS RATES OF APPLICATION \*

## GALLONS PER 100 LINEAR FEET

Width, ft.	9	12	15	16	20
Gal. per Sq. Yd.					
0.10	10.	13.3	16.7	17.8	22.2
0.15	15.	20.0	25.0	26.7	33.3
0.20	20.	26.7	33.3	35.6	44.4
0.25	25.	33.3	41.7	44.5	55.5
0.30	30.	40.0	50.0	53.4	66.6
0.35	35.	46.7	58.3	62.3	77.7
0.40	40.	53.3	66.7	71.2	88.8
0.45	45.	60.0	75.0	80.1	99.9
0.50	50.	66.7	83.4	89.0	111.1
1.25	125.	166.3	208.4	222.3	277.7
2.00	200.	266.7	333.4	355.6	444.4

## GALLONS PER MILE

Width, ft.	9	12	15	16	20
Gal. per Sq. Yd.					
0.10	530	700	880	940	1,170
0.15	790	1,050	1,320	1,410	1,760
0.20	1,050	1,410	1,760	1,880	2,350
0.25	1,320	1,760	2,200	2,350	2,930
0.30	1,580	2,110	2,640	2,820	3,520
0.35	1,840	2,460	3,080	3,290	4,110
0.40	2,110	2,820	3,520	3,750	4,690
0.45	2,330	3,170	3,960	4,220	5,280
0.50	2,640	3,520	4,400	4,690	5,870
1.25	6,600	8,800	11,000	11,730	14,670
2.00	10,560	14,080	17,600	18,770	23,470

\* From Pocket Reference for Highway Engineers, Asphalt Institute.

TABLE 40. TONS MINERAL AGGREGATE REQUIRED AT VARIOUS RATES OF APPLICATION \*

TONS PER 100 LINEAR FEET

Width, ft.	9	12	15	16	20
Lb. per Sq. Yd.					
10	.5	.67	.84	.89	1.11
15	.75	1.0	1.25	1.33	1.67
20	1.0	1.33	1.67	1.77	2.22
25	1.25	1.67	2.08	2.22	2.78
30	1.5	2.0	2.50	2.67	3.33
35	1.75	2.33	2.92	3.11	3.89
40	2.0	2.67	3.33	3.56	4.44
45	2.25	3.0	3.75	4.0	5.0
50	2.5	3.33	4.16	4.44	5.55

TONS PER MILE

Width, ft.	9	12	15	16	20
Lb. per Sq. Yd.					
10	27	35	44	47	59
15	40	53	66	71	88
20	53	71	88	94	117
25	66	88	110	118	147
30	80	106	133	141	176
35	93	124	155	165	205
40	106	141	177	188	234
45	119	159	199	212	264
50	133	177	221	236	293

\* From Pocket Reference for Highway Engineers, Asphalt Institute.

**TABLE 41. CUBIC YARDS OF AGGREGATE REQUIRED PER 100 LINEAR FEET AND PER MILE FOR VARIOUS LOOSE DEPTHS ON ROADS OF VARIOUS WIDTHS \***

Width of Road	Area		Cubic Yards for Various Loose Depths								
	Per	Sq. Yards	1"	1½"	2"	2½"	3"	3½"	4"	5"	6"
6'	100'	66.6	1.9	2.8	3.7	4.6	5.6	6.5	7.4	9.3	11.1
	Mile	3520.0	97.8	146.7	195.6	244.4	293.3	342.2	391.1	488.9	586.7
7'	100'	77.7	2.2	3.2	4.3	5.4	6.5	7.6	8.6	10.8	13.0
	Mile	4106.6	114.1	171.1	228.1	285.2	342.2	399.3	456.3	570.4	684.4
8'	100'	88.8	2.5	3.7	4.9	6.2	7.4	8.6	9.9	12.3	14.8
	Mile	4693.3	130.4	195.6	260.7	325.9	391.1	456.3	521.5	651.9	782.2
9'	100'	100.0	2.8	4.2	5.6	6.9	8.3	9.7	11.1	13.9	16.7
	Mile	5280.0	146.7	220.0	293.3	366.7	440.0	513.3	586.7	733.3	880.0
10'	100'	111.1	3.1	4.6	6.2	7.7	9.3	10.8	12.3	15.4	18.5
	Mile	5866.6	163.0	244.4	325.9	407.4	488.9	570.4	651.9	814.8	977.8
12'	100'	133.3	3.7	5.6	7.4	9.3	11.1	13.0	14.8	18.5	22.2
	Mile	7040.0	195.6	293.3	391.1	488.9	586.7	684.4	782.2	977.8	1173.3
14'	100'	155.5	4.3	6.5	8.6	10.8	13.0	15.1	17.3	21.6	25.9
	Mile	8213.3	228.1	342.2	456.3	570.4	684.4	798.5	912.6	1140.7	1368.9
16'	100'	177.7	4.9	7.4	9.9	12.3	14.8	17.3	19.8	24.7	29.6
	Mile	9386.6	260.7	391.1	521.5	651.9	782.2	912.6	1043.0	1303.7	1564.4
18'	100'	200.0	5.6	8.3	11.1	13.9	16.7	19.4	22.2	27.8	33.3
	Mile	10560.0	293.3	440.0	586.7	733.3	880.0	1026.7	1173.3	1466.7	1760.0
20'	100'	222.2	6.2	9.3	12.3	15.4	18.5	21.6	24.7	30.9	37.0
	Mile	11733.3	325.9	488.9	651.9	814.8	977.8	1140.7	1303.7	1629.6	1955.6
21'	100'	233.3	6.5	9.7	13.0	16.2	19.4	22.7	25.9	32.4	38.9
	Mile	12320.0	342.2	513.3	684.4	855.6	1026.7	1197.8	1368.9	1711.1	2053.3
23'	100'	255.5	7.1	10.6	14.2	17.7	21.3	24.8	28.4	35.5	42.6
	Mile	13493.3	374.8	562.2	749.6	937.0	1124.4	1311.9	1499.3	1874.1	2248.9
24'	100'	266.6	7.4	11.1	14.8	18.5	22.2	25.9	29.6	37.0	44.4
	Mile	14080.0	391.1	586.7	782.2	977.8	1173.3	1368.9	1564.4	1955.6	2346.7

Rolling compacts crushed aggregate base course approximately 20% and wearing course approximately 25%.

Ordinary bank gravel compacts approximately 33½%.

For road 5' wide take half of 10' quantity.

For road 22' wide add quantities for 10' and 12' widths.

For road 26' wide add quantities for 20' and 6' widths.

For road 28' wide take twice quantity for 14' width.

For road 30' wide take three times quantity for 10' width.

\* From Tarmac Handbook, Koppers Co.

TABLE 42. AREAS OF PAVEMENT SURFACES \*

WIDTH IN FEET	SQUARE FEET PER MILE	SQUARE YARDS PER MILE	SQUARE YARDS PER LINEAR FOOT
1	5,280	587	0.1111
8	42,240	4,693	0.8888
9	47,520	5,280	1.0000
10	52,800	5,867	1.1111
11	58,080	6,453	1.2222
12	63,360	7,040	1.3333
15	79,200	8,800	1.6667
16	84,480	9,387	1.7778
18	95,040	10,560	2.0000
20	105,600	11,733	2.2222
22	116,160	12,906	2.4444
24	126,720	14,080	2.6667
26	137,280	15,253	2.8888
28	147,840	16,426	3.1110
30	158,400	17,600	3.3333
32	168,960	18,773	3.5555
36	190,080	21,120	4.0000
40	211,200	23,467	4.4444
50	264,000	29,333	5.5556

\* From *Bitumuls Handbook*, American Bitumuls Co.

TABLE 43. LINEAR FEET COVERED BY 1 TON OF AGGREGATE AT VARIOUS RATES OF APPLICATION \*

Width, ft.	9	12	15	16	20
Lb. per Sq. Yd.					
10	200	150	120	113	90
15	133	100	80	75	60
20	100	75	60	56	45
25	80	60	48	45	36
30	67	50	40	38	30
35	57	43	34	32	26
40	50	38	30	28	23
45	44	33	27	25	20
50	40	30	24	23	18 <sup>¢</sup>

\* From *Pocket Reference for Highway Engineers*, Asphalt Institute.

**TABLE 44. WEIGHT AND VOLUME RELATIONS MINERAL AGGREGATES \***

BROKEN STONE

*Pounds per Cubic Yard*

Kind	Sp. Gr.	Loose Spread	Compacted
		45% Voids	30% Voids
Trap	2.8	2590	3300
	2.9	2680	3420
	3.0	2770	3540
	3.1	2870	3650
Granite	2.6	2400	3060
	2.7	2500	3180
	2.8	2590	3300
Limestone	2.6	2400	3060
	2.7	2500	3180
	2.8	2590	3300
Sandstone	2.4	2220	2830
	2.5	2310	2940
	2.6	2400	3060
	2.7	2500	3180

GRAVEL AND SAND

*Approximate Number of Pounds per Cubic Yard*

Voids	Weight	Voids	Weight
50%	2240	35%	2910
45%	2460	30%	3130
40%	2680	25%	3350

\* From *Pocket Reference for Highway Engineers*, Asphalt Institute.

**TABLE 45. WEIGHT AND VOLUME RELATIONS OF ASPHALTIC MATERIALS AT 60° F. \***

Specific Gravity	Pounds per Gallon	Gallons per Ton	Specific Gravity	Pounds per Gallon	Gallons per Ton	Specific Gravity	Pounds per Gallon	Gallons per Ton
0.930	7.745	258.2	0.980	8.162	245.0	1.030	8.578	233.2
0.935	7.786	256.8	0.985	8.203	243.8	1.035	8.620	232.0
0.940	7.828	255.6	0.990	8.245	242.6	1.040	8.662	230.8
0.945	7.870	254.2	0.995	8.287	241.4	1.045	8.704	229.8
0.950	7.911	252.8	1.000	8.328	240.2	1.050	8.745	228.6
0.955	7.953	251.4	1.005	8.370	239.0	1.055	8.787	227.6
0.960	7.995	250.2	1.010	8.412	237.8	1.10	9.161	218.3
0.965	8.036	248.8	1.015	8.453	236.6	1.20	9.994	200.1
0.970	8.078	247.6	1.020	8.495	235.4	1.30	10.826	184.8
0.975	8.120	246.4	1.025	8.537	234.2	1.40	11.659	171.6

\* From *Principles of Highway Construction*, Public Roads Administration.

TABLE 46. DISTANCE IN LINEAL FEET COVERED BY A 1000-GALLON DISTRIBUTOR TANK LOAD \*

Application Rate, gallons per square yard	Width of Spread, feet									
	2	3	4	5	6	7	8	9	10	11
0.1	45,000	30,000	22,500	18,000	15,000	12,857	11,250	10,000	9000	8182
0.15	30,000	20,000	15,000	12,000	10,000	8,571	7,500	6,667	6000	5455
0.2	22,500	15,000	11,250	9,000	7,500	6,429	5,625	5,000	4500	4091
0.25	18,000	12,000	9,000	7,200	6,000	5,143	4,500	4,000	3000	3273
0.3	15,000	10,000	7,500	6,000	5,000	4,286	3,750	3,333	3000	2727
0.333	13,500	9,000	6,750	5,400	4,500	3,857	3,375	3,000	2700	2455
0.35	12,857	8,571	6,429	5,143	4,286	3,673	3,214	2,857	2571	2338
0.4	11,250	7,500	5,625	4,500	3,750	3,214	2,813	2,500	2250	2045
0.45	10,000	6,667	5,000	4,000	3,333	2,857	2,500	2,222	2000	1818
0.5	9,000	6,000	4,500	3,600	3,000	2,571	2,250	2,000	1800	1636
0.6	7,500	5,000	3,750	3,000	2,500	2,143	1,875	1,667	1500	1364
0.667	6,750	4,500	3,375	2,700	2,250	1,929	1,688	1,500	1350	1227
0.7	6,429	4,286	3,214	2,571	2,143	1,837	1,607	1,429	1286	1169
0.75	6,000	4,000	3,000	2,400	2,000	1,714	1,500	1,333	1200	1091
0.8	5,625	3,750	2,813	2,250	1,875	1,607	1,406	1,250	1125	1023
0.9	5,000	3,333	2,500	2,000	1,667	1,429	1,250	1,111	1000	909
1.0	4,500	3,000	2,250	1,800	1,500	1,286	1,125	1,000	900	818
1.25	3,600	2,400	1,800	1,440	1,200	1,029	900	800	720	655
1.5	3,000	2,000	1,500	1,200	1,000	857	750	667	600	545
1.75	2,571	1,714	1,286	1,029	857	735	643	571	514	468
2.0	2,250	1,500	1,125	900	750	643	563	500	450	409
2.25	2,000	1,333	1,000	800	667	571	500	444	400	364
2.5	1,800	1,200	900	720	600	514	450	400	360	327

Application Rate, gallons per square yard	Width of Spread, feet								
	12	13	14	15	16	17	18	19	20
0.1	7500	6923	6429	6000	5625	5294	5000	4737	4500
0.15	5000	4615	4286	4000	3750	3529	3333	3158	3000
0.2	3750	3462	3214	3000	2813	2647	2500	2368	2250
0.25	3000	2769	2571	2400	2250	2118	2000	1895	1800
0.3	2500	2308	2143	2000	1875	1765	1667	1579	1500
0.333	2250	2077	1929	1800	1688	1588	1500	1421	1350
0.35	2143	1978	1837	1714	1607	1513	1429	1353	1286
0.4	1875	1731	1607	1500	1406	1324	1250	1184	1125
0.45	1667	1538	1429	1333	1250	1176	1111	1053	1000
0.5	1500	1385	1286	1200	1125	1059	1000	947	900
0.6	1250	1154	1071	1000	938	882	833	789	750
0.667	1125	1038	964	900	844	794	750	711	675
0.7	1071	989	918	857	804	756	714	677	643
0.75	1000	923	857	800	750	706	667	632	600
0.8	938	865	804	750	703	662	625	592	563
0.9	833	769	714	667	625	588	556	526	500
1.0	750	692	643	600	563	529	500	474	450
1.25	600	554	514	480	450	424	400	379	360
1.5	500	462	429	400	375	353	333	316	300
1.75	429	396	367	343	321	303	286	271	257
2.0	375	346	321	300	281	265	250	237	225
2.25	333	308	286	267	250	235	222	211	200
2.5	300	277	257	240	225	212	200	189	180

\* From Principles of Highway Construction, Public Roads Administration.



**TABLE 47. STANDARD ABRIDGED VOLUME CORRECTION TABLE FOR BITUMINOUS MATERIALS \***

[Volume at 60° F. occupied by unit volume at indicated temperature;  $t$  = observed temperature °F.;  $M$  = multiplier to reduce volume to 60° F.]

GROUP 0. SPECIFIC GRAVITY AT 60° F., ABOVE 0.966							
$t$	$M$	$t$	$M$	$t$	$M$	$t$	$M$
60	1.0000	145	0.9707	230	0.9425	315	0.9154
65	.9982	150	.9691	235	.9409	320	.9138
70	.9965	155	.9674	240	.9392	325	.9123
75	.9948	160	.9657	245	.9376	330	.9107
80	.9931	165	.9640	250	.9360	335	.9092
85	.9914	170	.9623	255	.9344	340	.9076
90	.9896	175	.9606	260	.9328	345	.9061
95	.9879	180	.9590	265	.9312	350	.9045
100	.9862	185	.9573	270	.9296	355	.9030
105	.9844	190	.9556	275	.9280	360	.9014
110	.9827	195	.9539	280	.9264	365	.8999
115	.9809	200	.9523	285	.9248	370	.8984
120	.9792	205	.9507	290	.9233	375	.8969
125	.9775	210	.9490	295	.9217	380	.8953
130	.9758	215	.9474	300	.9201	385	.8938
135	.9741	220	.9458	305	.9185	390	.8923
140	.9724	225	.9441	310	.9169	395	.8908
						400	.8893
GROUP 1. SPECIFIC GRAVITY AT 60° F., 0.850 TO 0.966							
$t$	$M$	$t$	$M$	$t$	$M$	$t$	$M$
60	1.0000	145	0.9667	230	0.9345	315	0.9034
65	.9980	150	.9647	235	.9326	320	.9016
70	.9960	155	.9628	240	.9307	325	.8998
75	.9940	160	.9608	245	.9289	330	.8980
80	.9921	165	.9590	250	.9270	335	.8962
85	.9901	170	.9570	255	.9252	340	.8945
90	.9881	175	.9551	260	.9234	345	.8927
95	.9861	180	.9532	265	.9215	350	.8909
100	.9841	185	.9513	270	.9197	355	.8892
105	.9822	190	.9494	275	.9179	360	.8874
110	.9803	195	.9476	280	.9160	365	.8856
115	.9783	200	.9457	285	.9142	370	.8839
120	.9763	205	.9438	290	.9124	375	.8821
125	.9744	210	.9419	295	.9106	380	.8804
130	.9724	215	.9401	300	.9088	385	.8786
135	.9705	220	.9382	305	.9070	390	.8769
140	.9686	225	.9363	310	.9052	395	.8752
						400	.8734

**GROUP 00. TAR PRODUCTS, A.A.S.H.O. GRADES RT-5, RT-6, RT-7, RT-8, RT-9, RT-10, RT-11, RT-12, RTCB-5, RTCB-6**

$t$	$M$	$t$	$M$	$t$	$M$	$t$	$M$
60	1.0000	105	0.9867	155	0.9723	205	0.9583
65	.9985	110	.9852	160	.9709	210	.9569
70	.9970	115	.9838	165	.9695	215	.9556
75	.9955	120	.9823	170	.9681	220	.9542
80	.9940	125	.9809	175	.9667	225	.9528
85	.9926	130	.9794	180	.9653	230	.9515
90	.9911	135	.9780	185	.9639	235	.9501
95	.9896	140	.9766	190	.9625	240	.9488
100	.9881	145	.9751	195	.9611	245	.9474
		150	.9737	200	.9597	250	.9461

\* From Principles of Highway Construction, Public Roads Administration.

TABLE 48. AMOUNTS OF MATERIAL PER SQUARE YARD FOR A TYPICAL PENETRATION MACADAM SURFACE \*

	BASE		SURFACE	
	Size	Amount	Size	Amount
Coarse stone	3 to 2 in.	285 lb.	2½ to 1½ in.	270 lb.
Bitumen		1.85 gal.		1.5 gal.
Medium stone	1 to ¾ in.	30 lb.	¾ in. to No. 4	30 lb.
Bitumen		0.3 gal.		0.5 gal.
Fine stone	1 to ¾ in.	25 lb.	¾ in. to No. 4	25 lb.
Bitumen				0.3 gal.
Stone chips	½ in. to No. 4	10 lb.	¾ in. to No. 8	15 lb.
Do			¾ in. to No. 8	10 lb.
Total aggregate		350 lb.		350 lb.
Total bitumen		2.15 gal.		2.3 gal.

\* From Principles of Highway Construction, Public Roads Administration.

## BITUMINOUS PAVING

Date June 10 194 0Report No. 12

Engineer \_\_\_\_\_

S. P. No. 2006-05F. A. P. No. 174

**DAILY BITUMINOUS REPORT (CONSTRUCTION) \***  
**FOR MACADAM, BITUM. TREATMENTS, MIX-IN-PLACE**

T. H. No. 56 From West Concord To Jct. T.H. 14  
 Inspector A. C. Johnson Contractor Pioneer Co.

Course	Station		Aggregate Lb. per Sq. Yd.	Bituminous Material		Applica- tion Temper- ature	Width of Material
	From	To		Gal. per Sq. Yd.	Per cent of Mix		
Base prime	326 + 00	356 + 00		0.22		110°	26'
Wearing	256 + 00	308 + 00	150	0.88	4.6	200°	24'
Wearing	308 + 00	326 + 00	100	0.60	4.7	200°	24'
Tack	308 + 00	326 + 00		0.07		200°	24'
Seal	0 + 00	56 + 00	18	0.30		220°	24'

## AGGREGATE GRADING

Course	Pit No. or Station	Total Per Cent Passing							
		¾	¾	¾	10	20	40	100	200
Wearing	506	100	98	80	47		18		3.1
Wearing	506	100	97	80	51		19		3.4
Seal	Doe Gravel Co.			100	5.0	2.0			

## BITUMINOUS MATERIALS USED

Course	Kind and Grade	Gallons Applied		
		Today	Prev.	To Date
Base prime	MC - 1	1,700	10,100	11,800
Tack	MC - 3	350	1,200	1,550
Wearing	MC - 3	25,300	101,000	126,300
Seal	RT - 9	4,450	15,000	19,450
Weather Temperature	A.M. clear 8 A.M. 67	P.M. clear 12 N. 85	5 P.M. 78	

## EQUIPMENT

Description	No. Units	Hours Worked
Traveling plant	1	15
Distributor	1	8
Trucks	5	40
Blade graders	3	24
Roller	1	10
Chip spreader	1	3
Sweeper	1	5
Drag broom	1	3
Transfer tank	1	15

## OPERATING TIME AND DELAYS

Time start 4:00 A.M. Time stop 7:30 P.M. Gross time 15½ Time delayed ½ Net operating time 15

Delays due to	<u>Lunch ½ hr.</u>
---------------	--------------------

Remarks: Aggregate mixed and coated very well.

Signed by \_\_\_\_\_

J. M. Smith

Project Engineer

\* From Minnesota State Highway Department.

# PAVING REPORT

161

Date \_\_\_\_\_ Engineer \_\_\_\_\_ Report No. \_\_\_\_\_  
 Type of pavement \_\_\_\_\_ PLANT-MIX BITUMINOUS INSPECTION S. P. No. \_\_\_\_\_  
 Width \_\_\_\_\_ DAILY PAVING REPORT \* F. A. P. No. \_\_\_\_\_  
 T. H. No. \_\_\_\_\_ From \_\_\_\_\_ To \_\_\_\_\_ Length \_\_\_\_\_  
 Engineer \_\_\_\_\_ Contractor \_\_\_\_\_  
 Street inspector \_\_\_\_\_ Plant inspector \_\_\_\_\_

Course	Station		Tons Mixture Placed	Area in Sq. Yd.	Yield Lb. per Sq. Yd.	Temperature When Laid
	From	To				
<b>Total</b>						

### EQUIPMENT

Spreading Machine			Total Hours Worked
Make and type	No.	Width	
Rollers			
Make and type	No.	Wt.	
Other Equipment			
Description	No.		

### PLACING AND FINISHING

	Good	Fair	Poor	Remarks
Workability				
Temperature				
Spreading				
Shoveling				
Raking				
Rolling				
Finished surface				

### HAUL DATA

Average round-trip time \_\_\_\_\_ Min.  
 Average length of haul \_\_\_\_\_ Miles

### WEATHER AND TEMPERATURE

Weather: A.M. \_\_\_\_\_ P.M. \_\_\_\_\_  
 Temperature: 7:00 A.M. \_\_\_\_\_ 10:00 A.M. \_\_\_\_\_  
 2:00 P.M. \_\_\_\_\_ 5:00 P.M. \_\_\_\_\_

### TIME DISTRIBUTION AND DELAYS

Time start \_\_\_\_\_ Time stop \_\_\_\_\_ Gross time \_\_\_\_\_ Time delayed \_\_\_\_\_ Net paving time \_\_\_\_\_

Moving	Weather	Non wk. days	Rock	Sand	Filler	Bit. cement	Chips
<b>Paver</b>	<b>Plant</b>	<b>Switching</b>	<b>Haul road</b>	<b>Trucks</b>	<b>Rollers</b>	<b>Base</b>	

Remarks \_\_\_\_\_

Signed by \_\_\_\_\_ Project Engineer

\* From Minnesota State Highway Department.

BITUMINOUS PAVING

\_\_\_\_\_  
Engineer

Date \_\_\_\_\_ Report No. \_\_\_\_\_  
 Type of \_\_\_\_\_ PLANT-MIX BITUMINOUS INSPECTION S. P. No. \_\_\_\_\_  
 Pavement \_\_\_\_\_ F. A. P. No. \_\_\_\_\_

**DAILY PLANT REPORT\***

T. H. No. \_\_\_\_\_ From \_\_\_\_\_ To \_\_\_\_\_ Length \_\_\_\_\_

Contractor \_\_\_\_\_ Location of plant \_\_\_\_\_ Type of plant \_\_\_\_\_  
 Engineer \_\_\_\_\_ Plant inspector \_\_\_\_\_ Street inspector \_\_\_\_\_

BATCH PROPORTIONS

	Wearing Course				Binder Course			
	Lb.	Per Cent	Lb.	Per Cent	Lb.	Per Cent	Lb.	Per Cent
Sand _____								
Filler _____								
Bit. cem. _____								
Batch totals _____								
Tons Mixed _____								

AGGREGATE GRADINGS

	Separate Bins				Composite Grading		
			Sand	Filler	Wearing C.		Binder C.
Total % _____							
Passing _____							
" 1½ _____							
" 1¼ _____							
" 1 _____							
" ¾ _____							
" ½ _____							
" ¼ _____							
" 4 _____							
" 10 _____							
" 20 _____							
" 40 _____							
" 80 _____							
" 100 _____							
" 200 _____							

MATERIALS USED

	Source	Tons Today	Tons Prev.	Tons to Date
Coarse agg. _____				
Fine agg. _____				
Filler _____				
Bit. cement _____				
Totals _____				

TEMPERATURES

	Max.	Min.	Aver.
C. Agg. _____			
Fine agg. _____			
Bit. cement _____			
Wear. course _____			
Binder course _____			

MIXING TIME

Mixing time _____	Sec.
Spec. req. min. _____	Sec.

Time start \_\_\_\_\_ Time stop \_\_\_\_\_ Gross time \_\_\_\_\_ Time delayed \_\_\_\_\_ Net operating time \_\_\_\_\_

Remarks: \_\_\_\_\_

Signed by \_\_\_\_\_

Project engineer

\* From Minnesota State Highway Department.

\_\_\_\_\_  
Engineer

BITUMINOUS PAVING ANALYSES \*

\_\_\_\_\_ 194

Client \_\_\_\_\_

Project \_\_\_\_\_

Material \_\_\_\_\_

Report No.				
Job sample No.				
Date laid				
Sampled by				
Taken at				
SCREENS AND SIEVES USED	ANALYSES		REQUIRED	
			Min. %	Max. %
Passing 200 Mesh Filler				
Bitumen content				

Remarks:

\_\_\_\_\_  
Inspector

\* From Haller Engineering Associates, Inc.

---

 Engineer
 

---

## ASPHALT REPORT \*

 Report for \_\_\_\_\_  
 Material \_\_\_\_\_  
 Project \_\_\_\_\_  
 Producer \_\_\_\_\_  
 Contractor \_\_\_\_\_ Quantity \_\_\_\_\_  
 Shipped via \_\_\_\_\_ Report No. \_\_\_\_\_ Date \_\_\_\_\_

Specific gravity @ 25° C.				
Flash point degrees F. (open cup)				
Asphalt content @ 100 pen.				
Furol viscosity @ ° C.				
Penetration 25° C. 100 g. 5 sec.				
Ductility, centimeters @ 25° C.				
Loss on evaporation 163° C. 5 hr.				
Penetration of residue from evaporation 25° C. 100 g. 5 sec.				
Total distillate % by volume to 320° F. (160° C.)				
Total distillate % by volume to 374° F. (190° C.)				
Total distillate % by volume to 437° F. (225° C.)				
Total distillate % by volume to 600° F. (315° C.)				
Total distillate % by volume to 680° F. (360° C.)				
Penetration residue from Distillation 25° C. 100 g. 5 sec.				
Ductility residue from Distillation cm. @ 25° C.				
Total bitumen (soluble in CS <sub>2</sub> )				

Remarks:

The above fulfills the specification requirements.

---

 Inspector

\* From Haller Engineering Associates, Inc.

# SANITARY CONSTRUCTION

## CHECK LIST FOR INSPECTORS

### SANITARY CONSTRUCTION

#### Inspectors' Equipment

Complete working drawings with accurate dimensions covering anchor bolts, sleeves, flexible couplings, expansion loops, etc., with adequate clearances for erection.

#### Procedure in Inspection

Anchor-bolt locations and wall castings should be checked for accuracy; make sure bolt threads are clean and not damaged.

Sufficient flexible couplings, sleeves, expansion loops, and similar fittings should be provided to reduce vibration and facilitate erection and dismantling of equipment and piping.

Base plates of machines should be set accurately and blocked, not grouted in until assembly of machine is complete. Adjust to level again and grout into position.

Check lubrication of all machines before operating. If equipment has stood around for a period, flushing oil should be used to remove sediment.

Flush out pipe lines, particularly sludge lines from clarifiers. Make sure there are no blocks of lumber, bits of concrete, or other debris in these lines to obstruct a clear passage.

Capacity tests should be run on centrifugal pumps by using a tank (clarifier, wet well, etc.).

Check weirs, making sure they are level.

Review erection instructions of equipment manufacturer, and check to see they have been followed.

Make sure motors are rotating in right direction for the equipment.

Where possible rotate motor and reducer by hand to make sure bearings are free.

Check seal in distributor to see that mercury has been placed properly.

Check gas-utilization equipment to make sure that drainage traps are correctly installed and valves prevent gas escape; that meters are not filled with water; that counterweights in relief devices are correct in size and function freely; that entire hook-up is installed correctly.

In high-rate filter plants, check size, grading, and cleanliness of rock. Dirt and undersized particles should not be allowed.

**Pipe Laying.** See p. 180.

**Filter sands** should be carefully controlled to fit the requirements of the specifications.

Take and send frequent samples to the laboratory for test for effective size and uniformity coefficient, or make these tests in the field; see p. 125.

Samples of sand should be taken by the quartering method; see p. 10.

See sections on Concrete, Structural Steel, Timber, Masonry, Welding, etc., for those particular phases of the work.



**PIPE LAYING  
PIPE**

**TABLE 49. CEMENT-ASBESTOS SEWER PIPE (TRANSITE)**

Pipe Size (inside diameter), inches	Class 1			Class 2			Class 3			Class 4		
	Shell Thick- ness, inches	Weight per Lin. Ft., lb.	Ultimate Strength 3-edge Bearing, lb. per lin. ft.	Shell Thick- ness, inches	Weight per Lin. Ft., lb.	Ultimate Strength 3-edge Bearing, lb. per lin. ft.	Shell Thick- ness, inches	Weight per Lin. Ft., lb.	Ultimate Strength 3-edge Bearing, lb. per lin. ft.	Shell Thick- ness, inches	Weight per Lin. Ft., lb.	Ultimate Strength 3-Edge Bearing, lb. per lin. ft.
4	0.39	4.9	4,125									
6	0.42	7.9	2,880									
8	0.48	11.9	3,100									
10	0.50	15.3	2,580	0.56	17.7	3,090	0.65	21.0	4,920			
12	0.54	19.9	2,370	0.64	23.6	3,850	0.74	28.6	5,100			
14	0.58	24.6	2,200	0.73	31.0	3,920	0.84	37.0	5,150			
16	0.62	30.2	2,120	0.82	40.6	4,050	0.94	47.8	5,280			
18	0.65	35.5	2,030	0.90	51.0	4,140	1.03	58.0	5,360	1.12	66.0	6,340
20	0.69	41.7	2,290	0.94	57.5	4,280	1.13	70.0	5,850	1.25	84.0	7,100
24	0.75	54.3	2,340	1.06	77.6	4,550	1.31	100.0	7,050	1.45	110.0	8,600
30	0.96	86.8	2,980	1.24	113.2	5,000	1.64	155.0	8,180	1.85	175.0	10,450
36	1.15	124.8	3,500	1.41	154.3	5,400	1.93	215.0	9,700	2.18	248.0	12,300

Standard laying length, 13 ft.  
Furnished only in straight lengths.  
Cast-iron fittings recommended for branch connections.

Ultimate strengths determined by tests made in accordance with procedure of  
A.S.T.M.  
All data furnished by Johns-Manville Corp.

TABLE 50. CLAY PIPE, STANDARD STRENGTH, A.S.T.M. SPEC. C-13

Size, in.	Laying Length		Maximum Difference in Length of Two Opposite Sides, in.	Outside Diameter of Barrel, in.		Inside Diameter of Socket at 1/2 in. above Base, in.		Depth of Socket, in.		Thickness of Barrel, in.		Thickness of Socket at 1/2 in. from Outer End, in.		Average Strength Requirements, min., lb. per lin. ft.		Weight per foot of Pipe *
	Nominal, ft.	Limit of Minus Variation, <sup>a</sup> in. per ft. of length		Min.	Max.	Min.	Max.	Nominal	Min.	Nominal	Min.	Nominal	Min.	Three-Edge-Bearing Method	Sand-Bearing Method	
4	2, 2 1/2, 3	3/4	3/16	4 7/8	5 3/8	5 3/4	6 1/4	1 3/4	1 1/2	1 1/2	3/8	3/8	1000	1430	9.0	
6	2, 2 1/2, 3	3/4	3/8	7 1/8	7 7/8	8 1/8	8 5/8	2 1/4	2	5/8	3/8	1/2	1000	1430	15.5	
8	2, 2 1/2, 3	3/4	7/16	9 1/4	9 3/4	10 1/2	11	2 1/2	2 1/4	3/4	1 1/8	1/2	1000	1430	23.8	
10	2, 2 1/2, 3	3/4	7/16	11 1/2	12	12 3/4	13 1/4	2 5/8	2 3/4	7/8	1 1/8	5/8	1100	1570	33.8	
12	2, 2 1/2, 3	3/4	7/16	13 3/4	14 5/8	15 3/4	15 3/4	2 3/2	2 1/2	1	1 1/8	3/4	1200	1710	46.8	
15	3, 4	3/4	3/2	17 3/8	17 3/8	18 3/8	19 1/4	2 3/8	2 3/8	1 1/4	1 1/8	5/8	1400	2000	67.7	
18	3, 4	3/4	3/2	20 5/8	21 7/8	22 1/2	23	3	2 3/4	1 1/2	1 3/8	1 1/8	1700	2480	97.7	
21	3, 4	3/4	3/2	24 1/8	25	25 3/8	26 3/4	3 1/2	3	1 3/4	1 5/8	1 3/8	2000	2860	139	
24	3, 4	3/4	3/2	27 1/2	28 1/2	29 3/8	30 3/8	3 3/4	3 1/8	2	1 7/8	1 3/8	2400	3430	180	
27	3, 4	3/4	3/2	31	32 1/8	33	34 1/8	3 1/2	3 1/4	2 1/4	2 1/8	1 1/2	2750	3980	277	
30	3, 4	3/4	3/2	34 3/8	35 3/8	36 1/2	37 1/4	3 5/8	3 3/8	2 3/8	2 3/8	1 3/4	3200	4570	382	
33	3, 4	3/4	3/2	37 5/8	38 1/2	39 1/2	41 1/4	3 3/4	3 1/2	2 3/2	2 1/2	2	3500	5000	500	
36	3, 4	3/4	3/2	40 3/4	42 1/4	43 1/4	44 3/4	4	3 3/4	2 3/4	2 5/8	2 1/8	3900	5570	632	

<sup>a</sup> There is no limit for plus variation.  
 \* From Robinson Clay Products Co.

TABLE 51. CLAY PIPE, EXTRA STRENGTH, A.S.T.M. SPEC. C-200

Nominal Size, in.	Laying Length		Maximum Difference in Length of Two Opposite Sides, in.	Outside Diameter of Barrel, <sup>b</sup> in.		Inside Diameter of Socket at 1/2 in. above Base, in.		Depth of Socket, in.		Thickness of Barrel, in.		Thickness of Socket at 1/2 in. from Outer End, in.		Average Strength Requirements, lb. per lin. ft.		Weight per Foot of Pipe *
	Nominal, ft.	Limit of Minus Variation, <sup>a</sup> in. per ft. of length		Min.	Max.	Min.	Max.	Nominal	Min.	Nominal	Min.	Nominal	Min.	Three-Edge-Bearing Method	Sand-Bearing Method	
6	2, 2 1/2, 3	3/4	3/8	7 1/2	8 3/8	8 3/8	8 3/8	2 1/4	1 1/2	9 1/2	1/2	7/16	2000	2850	16	
8	3	3/4	7/16	9 3/4	10 1/2	11	11	2 1/2	1 1/2	9 1/2	3/4	3/4	2000	2850	26	
10	3	3/4	7/16	12	12 3/4	13 1/4	13 1/4	2 3/8	1 3/8	1	7/8	9/16	2000	2850	38	
12	3	3/4	7/16	13 3/4	14 3/8	15 1/8	15 3/8	2 3/4	1 3/8	1 1/2	1 1/2	1 1/8	2250	3200	54	
15	3, 4	3/4	7/8	17 3/4	18 3/8	19 1/4	19 1/4	2 3/8	1 3/4	1 3/4	1 3/4	7/8	2750	3925	78	
18	3, 4	3/4	1	20 5/8	21 1/8	22 1/4	23	3	2 3/4	1 7/8	1 3/4	1 1/2	3300	4700	124	
21	3, 4	3/4	9/16	24 7/8	25 7/8	26 3/4	26 3/4	3 1/4	3	2 1/2	2	1 3/4	3850	5500	170	
24	3, 4	3/8	9/16	27 1/2	28 1/2	29 3/8	30 3/8	3 3/8	3 1/8	2 3/4	2 1/4	1 3/8	4400	6300	214	
30	3, 4	3/8	5/8	34 3/8	35 5/8	36 1/2	37 1/4	3 5/8	3 3/8	3	2 3/4	1 3/4	5000	7100	323	
36	3, 4	3/8	1 1/16	40 3/4	42 1/4	43 1/4	44 3/4	4	3 3/4	3 1/2	3 1/2	1 7/8	6000	8575	444	

<sup>a</sup> There is no limit for plus variation.

<sup>b</sup> The average actual inside diameters of pipe having the nominal thickness of barrel shown in Table 53 may be smaller than the nominal sizes.

\* From Robinson Clay Products Co.

TABLE 52. CORRUGATED METAL CULVERT PIPE

Inside Pipe Diam- eter, in.	Weight per Linear Foot, lb.				
	16 Gage	14 Gage	12 Gage	10 Gage	8 Gage
4					
6					
8	7.6	9.3			
10	9.3	11.4			
12	10.8	13.3	18.5		
15	13.3	16.4	22.7		
18	15.8	19.5	27.0		
21	18.3	22.5	31.2	39.7	
24	21.0	26.0	35.9	45.7	
30		31.7	43.9	55.9	
36		37.9	52.4	66.7	81.1
42		44.4	61.5	78.3	95.1
48		50.5	70.0	89.1	108.3
54		57.8	80.1	102.0	123.9
60			88.2	112.3	136.4
66			96.6	123.1	149.5
72			105.1	133.9	162.6
84				156.6	190.3

Furnished in any length in multiples of 2 ft.

Data furnished for Armeo Pipe by Shelt Co., Elmira, N. Y.

TABLE 53. NON-REINFORCED-CONCRETE SEWER PIPE, A.S.T.M. C-14-41

Internal Diameter, $D$ , in.	Laying Length, $L$ , ft.	Inside Diameter at Mouth of Socket, $D_s$ , in. <sup>a</sup>	Depth of Socket, $L_s$ , in.	Minimum Taper of Socket, $H$	Thickness of Barrel, $T$ , in.	Thickness of Socket, $T_s$	Average Strength, lb. per lin. ft.		Maximum Absorption, %	Limits of Permissible Variation in:			
							Three-Edge-Bearing Method	Sand-Bearing Method		Length, in. per ft. (-) <sup>b</sup>	Internal Diameter, in.		Depth of Socket, in. (-) <sup>b</sup>
										Spigot ( $\pm$ ) <sup>b</sup>	Socket, ( $\pm$ ) <sup>b</sup>		
4	2, 2½, 3	6	1½	1:20	9/16	The thickness of the socket ¼ in. from its outer end shall be not less than ¾ of the thickness of the barrel of the pipe.	1000	1500	8	¾	¾	¾	¾
6	2, 2½, 3	8¾	2	1:20	5/8		1100	1650	8	¾	¾	¾	¾
8	2, 2½, 3, 4	10¾	2½	1:20	¾		1300	1950	8	¾	¾	¾	¾
10	2, 2½, 3, 4	13	2½	1:20	7/8		1400	2100	8	¾	¾	¾	¾
12	2, 2½, 3, 4	15¾	2½	1:20	1		1500	2250	8	¾	¾	¾	¾
15	2, 2½, 3, 4	18¾	2½	1:20	1¼		1750	2620	8	¾	¾	¾	¾
18	2, 2½, 3, 4	22¼	2¾	1:20	1½		2000	3000	8	¾	¾	¾	¾
21	2, 2½, 3, 4	26	2¾	1:20	1¾		2200	3300	8	¾	¾	¾	¾
24	2, 2½, 3, 4	29½	3	1:20	2		2400	3600	8	¾	¾	¾	¾

<sup>a</sup> When pipes are furnished having an increase in thickness over that given in last column, then the diameter of socket shall be increased by an amount equal to twice the increase of thickness of barrel.

<sup>b</sup> The minus sign (-) alone indicates that the plus variation is not limited; the plus-and-minus sign ( $\pm$ ) indicates variation in both excess and deficiency in dimension.

Note. For weights and laying lengths, see Table 57.

TABLE 54. REINFORCED-CONCRETE SEWER PIPE, A.S.T.M. SPEC. C-76-41

Internal Diameter, in.	Strength Test Requirements, lb. per lin. ft.		Minimum Design Requirements <sup>a</sup>					
	Three-Edge-Bearing Method		Concrete, 3000 psi.		Concrete, 3500 psi.		Concrete, 4000 psi.	
	Load to Produce a 0.01-in. Crack	Ultimate Load	Shell Thickness, in.	Total Steel Area, sq. in. per lin. ft.	Shell Thickness, in.	Total Steel Area, sq. in. per lin. ft.	Shell Thickness, in.	Total Steel Area, sq. in. per lin. ft.
12	1,800	2,700	2	1 line	1 3/4	1 line	0.07	...
15	2,000	3,000	2 1/4	1 line	2	1 line	0.07	...
18	2,200	3,300	2 1/2	1 line	...	...	...	1 line
21	2,400	3,600	2 3/4	1 line	...	...	...	1 line
24	2,400	3,600	3	1 line	...	...	...	1 line
27	2,550	3,800	3	1 line	2 3/4	1 line	0.10	1 line
30	2,700	4,050	3 1/2	1 line	3	1 line	0.12	1 line
33	2,850	4,300	3 3/4	1 line	3 1/4	1 line	0.12	1 line
36	3,000	4,500	4	2 lines	3 1/2	1 line	0.14	1 line
42	3,200	4,800	4 1/2	2 lines	3 3/4	2 lines	0.20	2 lines
48	3,400	5,100	5	2 lines	3 3/4	2 lines	0.23	2 lines
54	3,700	5,550	5 1/2	2 lines	4 1/4	2 lines	0.27	2 lines
60	4,000	6,000	6	2 lines	4 1/2	2 lines	0.32	2 lines
66	4,250	6,350	6 1/2	2 lines	5	2 lines	0.38	2 lines
72	4,500	6,750	7	2 lines	5 1/2	2 lines	0.44	2 lines
78	.....	.....	7 1/2	2 lines	5 3/4	2 lines	0.47	2 lines
84	.....	.....	8	2 lines	.....	.....	0.47	.....
90	.....	.....	8	2 lines	.....	.....	.....	.....
96	.....	.....	8 1/2	2 lines	.....	.....	.....	.....
108	.....	.....	9	2 lines	.....	.....	.....	.....

<sup>a</sup> The distances from the center line of the reinforcement to the nearest surface of the concrete has been assumed in the design tables as 1 in.  
<sup>b</sup> Where two lines of steel are specified, a single line placed elliptically may be used, and the area of this shall be at least 50% of the total steel area specified in the design table. *Note.* For weights and laying lengths, see Table 57.

TABLE 56. STANDARD STRENGTH REINFORCED-CONCRETE CULVERT PIPE, A.S.T.M. SPEC. C-76-41

Internal Diameter of Pipe, in.	Concrete, 3,500 psi.			Concrete, 4,500 psi.			Strength Test Requirements, lb. per lin. ft. of pipe
	Minimum Shell Thickness, in.	Minimum Reinforcement, <sup>a</sup> sq. in. per lin. ft. of pipe barrel <sup>b</sup>		Minimum Shell Thickness, in.	Minimum Reinforcement, <sup>a</sup> sq. in. per lin. ft. of pipe barrel <sup>b</sup>		
		Circular Reinforcement in Circular Pipe	Elliptical Reinforcement in Circular Pipe and Circular Reinforcement in Elliptical Pipe		Circular Reinforcement in Circular Pipe	Elliptical Reinforcement in Circular Pipe and Circular Reinforcement in Elliptical Pipe	
12	2	1 line	0.07	88	1 line	0.08	2,250
15	2 1/4	1 line	0.09	125	1 line	0.11	2,625
18	2 1/2	1 line	0.12	160	1 line	0.14	3,000
24	3	1 line	0.17	260	1 line	0.20	3,000
30	3 1/2	1 line	0.22	370	1 line	0.28	3,375
36	4	2 lines, each 0.18	0.18	520	2 lines, each 0.22	0.25	4,050
42	4 1/2	2 lines, each 0.21	0.21	680	2 lines, each 0.31	0.31	4,725
48	5	2 lines, each 0.25	0.25	850	2 lines, each 0.37	0.37	5,400
54	5 1/2	2 lines, each 0.30	0.30	1,050	2 lines, each 0.41	0.41	5,850
60	6	2 lines, each 0.33	0.33	1,280	2 lines, each 0.45	0.45	6,000
66	6 1/2	2 lines, each 0.37	0.37	1,480	2 lines, each 0.48	0.48	6,300
72	7	2 lines, each 0.40	0.40	1,835	2 lines, each 0.51	0.51	6,600
78	7 1/2	2 lines, each 0.43	0.43	2,150	2 lines, each 0.54	0.54	6,600
84	8	2 lines, each 0.46	0.46	2,300	2 lines, each 0.54	0.54	6,600
90	8	2 lines, each 0.56	0.56	2,600	2 lines, each 0.54	0.54	6,600
96	8 1/2	2 lines, each 0.60	0.60	2,750	2 lines, each 0.54	0.54	6,600
102	8 1/2	2 lines, each 0.72	0.72	3,050	2 lines, each 0.54	0.54	6,600
108	9	2 lines, each 0.78	0.78	3,450	2 lines, each 0.54	0.54	6,600

<sup>a</sup> The distance from the center line of the reinforcement to the nearest surface of the concrete has been assumed in the design tables as 1 1/4 in. for pipe with a shell 2 1/4 in. or more in thickness.

<sup>b</sup> For 2 lines or elliptical reinforcement, provide 1-in. cover.

<sup>c</sup> From *Universal Concrete Pipe Co. for angles and grooves pipe.*

<sup>d</sup> Test loads for sand-bearing tests shall be 1 1/2 times those specified in this table for the three-edge-bearing tests.

**TABLE 56. EXTRA-STRENGTH REINFORCED-CONCRETE CULVERT PIPE, A.S.T.M. SPEC. C-76-41**

Internal Diameter of Pipe, in.	Concrete, 4500 psi.			Strength Test Requirements, lb. per lin. ft. of pipe		Weight per Lin. Ft. in Lb. <sup>d</sup>
	Minimum Shell Thickness, in.	Minimum Reinforcement, <sup>a</sup> sq. in. per lin. ft. of pipe barrel <sup>b</sup>		Three-Edge-Bearing Method <sup>c</sup>		
		Circular Reinforcement in Circular Pipe	Elliptical Reinforcement in Circular Pipe and Circular Reinforcement in Elliptical Pipe	Load to Produce a 0.01-in. Crack	Ultimate Load	
24	3	1 line 0.26	1 line 0.20	4,000	6,000	260
30	3½	1 line 0.31	1 line 0.24	5,000	7,500	370
36	4	2 lines, each 0.28	1 line 0.28	6,000	9,000	520
42	4½	2 lines, each 0.33	1 line 0.33	7,000	10,500	680
48	5	2 lines, each 0.38	1 line 0.38	8,000	12,000	850
54	5½	2 lines, each 0.44	1 line 0.44	9,000	13,500	1,050
60	6	2 lines, each 0.50	1 line 0.50	9,000	15,000	1,280
66	6½	2 lines, each 0.56	1 line 0.56	9,500	16,500	1,480
72	7	2 lines, each 0.60	1 line 0.60	9,900	18,000	1,835
78	7½	2 lines, each 0.65	1 line 0.65	.....	.....	2,150
84	8	2 lines, each 0.72	1 line 0.72	.....	.....	2,300
90	8	2 lines, each 0.84	1 line 0.84	.....	.....	2,600
96	8½	2 lines, each 0.90	1 line 0.90	.....	.....	2,750
102	8½	2 lines, each 1.08	1 line 1.08	.....	.....	3,050
108	9	2 lines, each 1.17	1 line 1.17	.....	.....	3,450

<sup>a</sup> The distance from the center line of the reinforcement to the nearest surface of the concrete has been assumed in the design tables as 1½ in. for pipe with a shell 2½ in. or more in thickness.

<sup>b</sup> For 2 lines or elliptical reinforcement provide 1-in. cover.

<sup>c</sup> Test loads for sand-bearing tests shall be 1½ times those specified in this table for the three-edge-bearing tests.

<sup>d</sup> From Universal Concrete Pipe Co. for tongue and groove pipe.



TABLE 57. CONCRETE PIPE, WEIGHTS AND LAYING LENGTHS \*

NON-REINFORCED SEWER PIPE A.S.T.M. C-14-41				BELL-END EXTRA-STRENGTH CULVERT PIPE C-76-41			
Inside Diameter, in.	Length, ft.	Wall Thick- ness, in.	Weight per Lineal Foot, lb.	Inside Diameter, in.	Length, ft.	Wall Thick- ness, in.	Weight per Lineal Foot, lb.
6	3	1	25	12	4	2	100
8	3	1	35	15	4	2 $\frac{1}{4}$	150
10	3	1 $\frac{1}{8}$	48	18	4	2 $\frac{1}{2}$	205
12	4	1 $\frac{1}{4}$	60	21	4	2 $\frac{3}{4}$	255
15	4	1 $\frac{1}{2}$	90	24	4	3	320
18	4	1 $\frac{3}{4}$	120	30	4	3 $\frac{1}{2}$	470
21	4	2	190	36	4	4	600
24	4	2 $\frac{1}{4}$	225	42	4	4 $\frac{1}{2}$	750
24	4	2 $\frac{5}{8}$	255	48	4	5	1000

MACHINE BELL AND SPIGOT REINFORCED-CONCRETE PIPE C-75-41 AND C-76-41				TONGUE AND GROOVE REINFORCED-CONCRETE PIPE C-75-41 3000 psi Concrete C-76-41 Table 55 3500 psi Concrete C-76-41 Table 56 4500 psi Concrete			
12	4	1 $\frac{3}{4}$	90	6	3	1 $\frac{3}{4}$	48
15	4	2	125	8	4	2	65
18	4	2 $\frac{1}{4}$	160	10	4	2	80
21	4	2 $\frac{3}{8}$	205	12	4	2	88
24	4	2 $\frac{5}{8}$	260	15	4	2 $\frac{1}{4}$	125
27	4	2 $\frac{3}{4}$	300	18	4	2 $\frac{1}{2}$	160
30	4	3	370	21	4	2 $\frac{3}{4}$	205
36	4	3 $\frac{1}{2}$	510	24	4	3	260
42	4	3 $\frac{3}{4}$	660	27	4	3 $\frac{1}{4}$	310
48	4	4 $\frac{1}{4}$	835	30	4	3 $\frac{1}{2}$	370
				33	4	3 $\frac{3}{4}$	450
				36	4	4	520
				39	4	4 $\frac{1}{4}$	600
				42	4	4 $\frac{1}{2}$	680
				45	4	4 $\frac{3}{4}$	760
				48	4	5	850
				54	4	5 $\frac{1}{2}$	1050
				60	4	6	1280
				66	4', 5', 6'	6 $\frac{1}{2}$	1480
				72	4', 5', 6'	7	1835
				78	4', 5', 6'	7 $\frac{1}{2}$	2150
				84	4', 5', 6'	8	2300
				90	4', 5', 6'	8	2600
				96	4', 5', 6'	8 $\frac{1}{2}$	2750
				102	4', 5', 6'	8 $\frac{1}{2}$	3050
				108	4', 5', 6'	9	3450

TONGUE AND GROOVE REINFORCED- CONCRETE PIPE C-75-41 3500 psi Concrete C-76-41 Table 55 4500 psi Concrete			
12	4	1 $\frac{3}{4}$	75
15	4	2	110
18	4	2 $\frac{1}{4}$	140
24	4	2 $\frac{5}{8}$	225
30	4	3	315
36	4	3 $\frac{1}{2}$	450
42	4	3 $\frac{3}{4}$	560
48	4	4 $\frac{1}{4}$	720
54	4	4 $\frac{3}{8}$	880
60	4	5	1060

\* From Universal Concrete Pipe Co.

**TABLE 58. AMERICAN WATER WORKS ASSOCIATION STANDARD CAST-IRON PIPE \***

Nominal Inside Diameter, in.	Class A 100-Ft. Head 43 Lb. Pressure		Class B 200-Ft. Head 86 Lb. Pressure		Class C 300-Ft. Head 130 Lb. Pressure		Class D 400-Ft. Head 173 Lb. Pressure	
	Thick-ness, in.	Approximate Weight per Ft., lb.	Thick-ness, in.	Approximate Weight per Ft., lb.	Thick-ness, in.	Approximate Weight per Ft., lb.	Thick-ness, in.	Approximate Weight per Ft., lb.
3	0.39	14.5	0.42	16.2	0.45	17.1	0.48	18.0
4	0.42	20.0	0.45	21.7	0.48	23.3	0.52	25.0
6	0.44	30.8	0.48	33.3	0.51	35.8	0.55	38.3
8	0.46	42.9	0.51	47.5	0.56	52.1	0.60	55.8
10	0.50	57.1	0.57	63.8	0.62	70.8	0.68	76.7
12	0.54	72.5	0.62	82.1	0.68	91.7	0.75	100.0
14	0.57	89.6	0.66	102.5	0.74	116.7	0.82	129.2
16	0.60	108.3	0.70	125.0	0.80	143.8	0.89	158.3
18	0.64	129.2	0.75	150.0	0.87	175.0	0.96	191.7
20	0.67	150.0	0.80	175.0	0.92	208.3	1.03	229.2
24	0.76	204.2	0.89	233.3	1.04	279.2	1.16	306.7
30	0.88	291.7	1.03	333.3	1.20	400.0	1.37	450.0
36	0.99	391.7	1.15	454.2	1.36	545.8	1.58	625.0
42	1.10	512.5	1.28	591.7	1.54	716.7	1.78	825.0

\* From Handbook of Cast Iron Pipe by C. I. Pipe Research Assn.

Water hammer of ordinary intensity allowed for in the above table. Weights based on 12-ft. length.

**TABLE 59. FEDERAL SPECIFICATIONS, WW-P-421 STANDARD**

Nominal Inside Diameter, in.	100-lb. Class † or Max. Working Pressure		150-lb. Class ‡ or Max. Working Pressure		200-lb. Class † or Max. Working Pressure		250-lb. Class † or Max. Working Pressure	
	Thick-ness, in.	Approximate Weight per Ft., lb.	Thick-ness, in.	Approximate Weight per Ft., lb.	Thick-ness, in.	Approximate Weight per Ft., lb.	Thick-ness, in.	Approximate Weight per Ft., lb.
3			0.33	12.5			0.36	13.8
4			0.34	16.1			0.38	18.1
6			0.37	25.7			0.43	28.7
8			0.42	38.6	0.46	41.6	0.50	44.6
10			0.47	52.2	0.52	57.2	0.57	62.3
12			0.50	66.1	0.57	74.1	0.62	81.1
14	0.48	74.9	0.55	86.9	0.62	97.0	0.69	108.0
16	0.52	92.1	0.60	108.1	0.68	121.6	0.75	133.6
18	0.56	111.4	0.65	130.4	0.74	147.9	0.83	164.9
20	0.58	129.0	0.68	152.0	0.78	173.6	0.88	193.6
24	0.64	169.9	0.76	202.9	0.88	233.1	1.00	262.1

† From American Cast Iron Pipe Co.

‡ From Federal Specifications WW-P-421.

Water hammer of ordinary intensity allowed for in the above table. Weights based on 16-ft. length. 100 lb. Class—weights for Class B fittings; 150 lb., 200 lb., 250 lb. Classes—weights for Class D fittings.

TABLE 60. STANDARD THICKNESSES AND WEIGHTS OF CAST-IRON PIT CAST PIPE \*

Size Inches	Class 50			Class 100			Class 150			Class 200			Class 250			Class 300			Class 350		
	50 Lb. Pressure			100 Lb. Pressure			150 Lb. Pressure			200 Lb. Pressure			250 Lb. Pressure			300 Lb. Pressure			350 Lb. Pressure		
	115 Feet Head			231 Feet Head			346 Feet Head			462 Feet Head			577 Feet Head			693 Feet Head			808 Feet Head		
	Thick-ness, inches	Wt. Based on 12 Ft. Lgh.†	Per Foot	Thick-ness, inches	Wt. Based on 12 Ft. Lgh.†	Per Foot	Thick-ness, inches	Wt. Based on 12 Ft. Lgh.†	Per Foot	Thick-ness, inches	Wt. Based on 12 Ft. Lgh.†	Per Foot	Thick-ness, inches	Wt. Based on 12 Ft. Lgh.†	Per Foot	Thick-ness, inches	Wt. Based on 12 Ft. Lgh.†	Per Foot	Thick-ness, inches	Wt. Based on 12 Ft. Lgh.†	Per Foot
3	.37	14.2	170	.37	170	170	.37	14.2	170	.37	14.2	170	.37	14.2	170	.37	14.2	170	.37	14.2	170
4	.40	19.2	230	.40	19.2	230	.40	19.2	230	.40	19.2	230	.40	19.2	230	.40	19.2	230	.40	19.2	230
6	.43	30.0	360	.43	30.0	360	.43	30.0	360	.43	30.0	360	.43	30.0	360	.43	30.0	360	.43	30.0	360
8	.46	42.9	515	.46	42.9	515	.46	42.9	515	.46	42.9	515	.46	42.9	515	.46	42.9	515	.46	42.9	515
10	.50	57.1	685	.50	57.1	685	.50	57.1	685	.50	57.1	685	.50	57.1	685	.50	57.1	685	.50	57.1	685
12	.54	73.2	880	.54	73.2	880	.54	73.2	880	.54	73.2	880	.54	73.2	880	.54	73.2	880	.54	73.2	880
14	.58	85.4	1,025	.58	85.4	1,025	.58	85.4	1,025	.58	85.4	1,025	.58	85.4	1,025	.58	85.4	1,025	.58	85.4	1,025
16	.63	105.4	1,265	.63	105.4	1,265	.63	105.4	1,265	.63	105.4	1,265	.63	105.4	1,265	.63	105.4	1,265	.63	105.4	1,265
18	.68	127.3	1,535	.68	127.3	1,535	.68	127.3	1,535	.68	127.3	1,535	.68	127.3	1,535	.68	127.3	1,535	.68	127.3	1,535
20	.66	148.8	1,785	.71	168.8	1,905	.73	188.8	2,265	.83	252.5	2,450	.92	322.5	2,665	.97	352.5	2,865	1.05	382.5	3,065
24	.74	198.8	2,385	.80	212.9	2,555	.83	232.5	3,030	1.00	269.2	3,230	1.08	288.3	3,460	1.15	307.1	3,690	1.22	326.2	3,920
26	.77	228.2	2,460	.84	241.3	2,630	.87	261.3	3,080	1.10	281.3	3,280	1.19	301.3	3,530	1.22	321.3	3,780	1.28	341.3	4,030
30	.87	324.2	3,610	1.05	420.8	3,690	1.22	491.3	4,805	1.43	578.3	6,940	1.54	667.1	7,405	1.61	716.2	8,160	1.68	765.3	9,220
36	1.07	497.3	5,970	1.25	637.9	6,950	1.35	737.9	7,655	1.53	749.2	8,990	1.71	862.9	9,635	1.77	912.0	10,780	1.83	967.1	11,925
48	1.18	638.8	7,510	1.37	726.3	8,715	1.46	799.6	9,595	1.73	940.0	11,280	2.02	1,077.1	12,925	2.02	1,077.1	12,925	2.02	1,077.1	12,925
54	1.30	777.1	9,325	1.51	906.3	10,875	1.63	997.1	11,965	1.90	1,168.8	14,025	2.21	1,333.8	16,005	2.21	1,333.8	16,005	2.21	1,333.8	16,005
60	1.39	922.5	11,070	1.63	1,077.1	12,925	1.89	1,270.9	15,250	2.20	1,488.3	17,860	2.38	1,594.6	19,135	2.38	1,594.6	19,135	2.38	1,594.6	19,135

\* From American Standard Assn., Spec. A51.8-1939.

† Including bell and spigot head. Calculated weight of pipe rounded off to nearest 5 pounds.

Note. These weights are for pipe laid without blocks, on flat bottom trench, with tamped backfill, under 5 feet of cover.

**TABLE 61. APPROXIMATE QUANTITIES OF MATERIALS USED PER JOINT FOR WATER SERVICE \***

Nominal Diameter, In.	Pounds of Joint Compound 2½" Joint Depth †	Pounds of Hemp per Joint	Pounds of Lead in Joint 2" Deep	Pounds of Lead in Joint 2¼" Deep	Pounds of Lead in Joint 2½" Deep
3		0.18	6.00	6.50	7.00
4	2.00	0.21	7.50	8.00	8.75
6	3.00	0.31	10.25	11.25	12.25
8	4.00	0.44	13.25	14.50	15.75
10	5.00	0.53	16.00	17.50	19.00
12	6.00	0.61	19.00	20.50	22.50
14	7.00	0.81	22.00	24.00	26.00
16	8.25	0.94	30.00	33.00	35.75
18	9.25	1.00	33.80	36.90	40.00
20	10.50	1.25	37.00	40.50	44.00
24	13.00	1.50	44.00	48.00	52.50

\* Adapted from U. S. Pipe and Foundry Co.

† Approximate only; will vary with kind of material used.

Note. Weight of lead is based on std. wt. = 0.41 lb. per cu. in. This weight may vary 15% depending on purity.

TABLE 62. STEEL PIPE, A.S.T.M. A53-44, WEIGHTS AND DIMENSIONS

Pipe Diameter Nominal Sizes, in.	Outside Diameter, in.	Number of Threads per inch	Standard-Weight Pipe				Extra-Strong Pipe				Double Extra-Strong Pipe	
			Schedule 30		Schedule 40		Schedule 60		Schedule 80		Thickness, in.	Weight of Pipe, lb. per ft., Plain Ends
			Thickness, in.	Wt. of Pipe, lb. per ft., Threaded and with Couplings	Thickness, in.	Wt. of Pipe, lb. per ft., Threaded and with Couplings	Thickness, in.	Weight of Pipe, lb. per ft., Plain Ends	Thickness, in.	Weight of Pipe, lb. per ft., Plain Ends		
2	2.375	11½		0.154	3.68	0.218	5.02	0.436	9.03			
4	4.500	8		0.237	10.89	0.337	14.98	0.674	27.54			
6	6.625	8		0.280	19.18	0.432	28.57	0.864	53.16			
8	8.625	8	0.277	25.00	28.81	0.500	43.39	0.875	72.42			
10	10.750	8	0.307	35.00	41.13	0.500	54.74					
12	12.750	8	0.330	45.00	50.71	0.500	65.41					

Sizes larger than 12 in. are specified by their outside diameter, O.D., and thickness. These larger sizes are furnished with plain ends, unless otherwise specified. The weights for O.D. pipe are given by manufacturers' published standards although it is possible to calculate the theoretical weights for any given size and wall thickness on the basis of 1 cu. in. of steel weighing 0.2833 lb.

The table does not give complete list of sizes less than 6 in.

**TABLE 63. CEMENT-ASBESTOS WATER PIPE (TRANSITE)**

Pipe Size,* in.	Class 50		Class 100		Class 150		Class 200	
	Shell Thick-ness, in.	Weight per Lin. Ft., lb.	Shell Thick-ness, in.	Weight per Lin. Ft., lb.	Shell Thick-ness, in.	Weight per Lin. Ft., lb.	Shell Thick-ness, in.	Weight per Lin. Ft., lb.
3	0.33	3.6	0.35	3.8	0.44	4.6	0.60	6.6
3½	0.33	4.2	0.35	4.4	0.45	5.4	0.60	7.5
4	0.33	4.7	0.35	5.0	0.45	6.0	0.60	8.4
4½	0.34	5.4	0.36	5.6	0.48	7.3	0.64	10.0
5	0.35	6.2	0.37	6.4	0.51	8.6	0.68	11.8
6	0.36	7.6	0.38	7.8	0.55	10.7	0.75	15.4
7	0.38	9.3	0.41	9.8	0.61	14.1	0.82	19.5
8	0.42	11.7	0.44	11.9	0.65	16.8	0.88	23.7
10	0.44	15.2	0.59	19.8	0.85	28.0	1.10	37.0
12	0.48	19.8	0.68	27.6	0.98	38.6	1.24	49.6
14	0.52	24.8	0.78	36.6	1.13	51.6	1.44	67.0
16	0.56	30.6	0.88	47.0	1.25	65.0	1.65	87.8
18	0.59	35.9	0.97	58.2	1.39	81.2	1.87	112.0
20	0.63	42.5	1.07	71.2	1.53	99.5	2.09	139.5
24	0.69	55.5	1.25	99.3	1.82	141.5	2.48	199.0
30	0.90	89.2	1.54	150.6	2.29	221.0	3.12	310.0
36	1.09	126.3	1.83	211.0	2.80	318.0	3.74	435.0

\* Pipe size is inside diameter except sizes 4, 6, and 8 in. in Class 150 which are 3.95, 5.85, and 7.85 in., respectively.

Class of pipe is same as allowable working pressure in pounds per square inch. Furnished in straight lengths only, standard length = 13 ft.

## CHECK LIST FOR INSPECTORS

### PIPE LAYING

#### Inspectors' Equipment

Complete set of plans, specifications, and approved shop drawings.

Calipers.

6-ft. rule, 50-ft. tape and mason's level.

Plumb bob and line.

**Procedure in Inspection**

Check all pipe delivered for conformity with specification requirements of size, thickness, and reinforcement. Check pipe thickness with calipers and compare with tables, pp. 166-179.

Check all pipe and fittings for cracks or other defects before laying.

When concrete pipe is not inspected at the plant, have contractor cut into 5% of pipe delivered to job in order to check size and number of lines of reinforcing for verification of specification requirements.

Accept no elliptically reinforced pipe unless top is properly marked on outside of pipe. When installing such pipe, require exact centering of each piece.

Report to superior any unsatisfactory subgrade condition which may require special treatment such as removal of unsatisfactory material, consolidation of subgrade with stone or gravel, blocking, reinforced-concrete cradle, or pile support.

Permit no variation from type of bedding called for by plans or specifications except as directed. Remember that such change may require heavier pipe.

Where rock occurs, be sure earth, sand or gravel cushion is provided.

When laying bell and spigot or tongue and groove pipe, require spigot or tongue to be inserted to proper depth and center.

Always require asbestos-cement pipe to be laid with proper space between ends at each joint. See that bells are laid upgrade and excavation is carried on upgrade.

Require mechanical joints to be uniformly bolted, and welded joints to be thoroughly cleaned before welding begins.

Insist upon removal of water from trench where jointing is in progress, and require joints to be clean before lead or compound is poured.

Check each length as laid for size, strength, line, and grade.

Wherever bends or tees occur and in back of hydrants, require proper backing with concrete to prevent joints from opening under pressure.

Do not allow backfill to be placed over joints until pressure test has been made. If covered, require joint to be uncovered during test.

Require backfill to be placed exactly as specified.

Where pipe lines must pass through a fill as is common in the construction of treatment plants, see that pipes are supported by piers (or by other methods) resting on undisturbed soil.

Conduct tests for leakage in water mains and infiltration in sewer lines; see specifications.

Disinfection of pipes and tanks.

Do not place material under or around pipes which will have the effect of making a subdrain of trench.

# REPORT ON PIPE LAYING

181

\_\_\_\_\_  
Engineer

## REPORT ON CLAY AND CONCRETE PIPE \* SHOP INSPECTION

Material \_\_\_\_\_  
 Project \_\_\_\_\_  
 Producer \_\_\_\_\_  
 Contractor \_\_\_\_\_ Date \_\_\_\_\_

Sample taken from					Reported to
Quantity represented					
Marks on sample					
Sampled by					
Date taken					
Date rec'd at lab.					
Job sample No.					
Laboratory report No.					

	Required	
	Min.	Max.
Internal diameter of pipe, in.		
External diameter of pipe, in.		
Thickness of pipe, in.		
Internal diameter of bell, in.		
External diameter of bell, in.		
Thickness of bell, in.		
Total length of pipe, ft.		
Total length of bearing, ft.		
Load applied at first crack, lb.		
Load per lineal foot at first crack, lb.		
Maximum load applied, lb.		
Maximum load per lineal foot, lb.		

### ABSORPTION TEST

Weight after immersion, grams					
Weight after drying, grams					
Loss of weight					
Absorption, %					

### REINFORCEMENT

Number of lines of reinforcing					
Area of circular reinforcing per ft. of pipe, sq. in.					
Number of longitudinals					
Total area of longitudinals, sq. in.					

Remarks:  
 The above tests do fulfill A.S.T.M. Spec. \_\_\_\_\_  
 do not \_\_\_\_\_

\_\_\_\_\_  
Inspector

\* From Haller Engineering Associates, Inc.



# MISCELLANEOUS

## INSPECTOR'S TIME RECORD

TUTTLE, SEELYE, PLACE & RAYMOND

Week ending _____ 194____ Name <u>Smith</u>		Breakdown of Hours Worked on Each Job							Total Hours	Holidays, Vacation, and Sick Leave Allowed
Date	Description of Work Performed									
12/1	Adm.	6						6		
2		8						8		
3		10						10		
4		10						10		
5										
6		5						5		
7		15						15		
<b>Total Hours</b>		54						54		
<b>Total Credit Hours</b> <u>61</u>										

Breakdown in Hours Worked	
Job	Credit Hr
<b>Holidays, Vacation, Sick Leave</b>	
<b>Total</b>	

Employee \_\_\_\_\_

Approved \_\_\_\_\_



## REPORT ON AIRFIELD RUNWAYS

## INSPECTOR'S DAILY REPORT

## AIRFIELD RUNWAYS

TUTTLE, SEELYE, PLACE & RAYMOND  
 ARCHITECT—ENGINEER  
 FORT DIX, NEW JERSEY

Directive No. \_\_\_\_\_ Contract No. \_\_\_\_\_ Report No. \_\_\_\_\_  
 Prime contractor \_\_\_\_\_ Date \_\_\_\_\_  
 Subcontractor \_\_\_\_\_  
 Weather \_\_\_\_\_ Temp. 8 A.M. \_\_\_\_\_ 1 P.M. \_\_\_\_\_ 5 P.M. \_\_\_\_\_

Items	Kind	Quantity				Location
		Units	Lin. Ft.	Sq. Yd.	Cu. Yd.	
<i>Roads</i>						
Excavation						
Borrow						
Fine grading						
Base						
Top						
Seal coat						
Shoulders						
Ditching						
Culverts and drains						
Foundation material						
Water mains						
Valves						
Hydrants						
Specials						
Sanitary sewer mains						
Manholes						
Specials						
Storm sewer mains						
Manholes						
Inlets						
Head walls						







## CONTRACTOR'S DAILY REPORT

## GENERAL CONTRACTOR'S DAILY REPORT

Date 10-4-45Weather Clear

Job \_\_\_\_\_

Temperature \_\_\_\_\_

	Mechanics		Laborers		Foreman		
	No.	Time	No.	Time	No.	Time	
Superintendent	1						
Watchman							
Timekeepers	1						
Excavation							
Engineer	1	7					Hoisting materials and taking down rubbish, etc.
Forms							
Laborers			17	119	1	8	Handling materials for ovens—7th floor Chipping and cutting cols. and beams.
Concrete							Cleaning and taking down rubbish, etc. from 7th, 8th, and 9th floors.
Cem. finish							Loading truck with rubbish. Helping carpenters.
Rein. steel							
Masonry							
Carpentry	11	77					Shoring for center line for ovens. Making up benches for lathers. Building forms for cols. Running power-saw and filing saws. Framing haunches. Shoring forms over ovens.

Equipment Truck; hauling rubbish away.

Subcontractors Kalman. Watering Floors.

Excavation  
Struct. steel  
Misc. & orn. iron  
Cut stone  
Plumbing  
Heating  
Electric  
Waterproofing  
Hollow metal  
Kalamein  
Rfg. & sheet metal

Steel sash  
Calking  
Lathing  
Plastering  
Marble and tile  
Floor covering  
Weatherstripping  
Metal equipment  
Painting  
Glazing

Remarks Wreckers—Cutting arches on 9th floor. Cutting wood floor. 7th floor. Removing rubbish, etc., from 9th floor.

Visitors \_\_\_\_\_

Signed \_\_\_\_\_

Supt. \_\_\_\_\_

Sheet No. \_\_\_\_\_

## JOB POWER

In order to give the field engineer a general perspective of job power, the following is submitted.

Air compressors used in construction are of various types and sizes.

The most common type for the usual construction job is the portable type mounted on wheels for easy moving.

Compressor should be placed in a safe location to avoid injury but as close to operations as possible in order to avoid expensive labor and material in pipe lines, and to avoid decreased efficiency due to line losses, leaky joints, and actual breakage of line resulting from accident or carelessness.

Compressor capacity is rated on the actual cubic feet of air delivered at a designated pressure, usually 100 p.s.i.

The usual capacities for portable compressors are 105 cu. ft., 210 cu. ft., 315 cu. ft., 365 cu. ft., and 500 cu. ft.

There are many air tools for use with compressors; some of the more common are listed below:

Drills, jackhammers, wagon drills, drifters—for drilling holes in rock for use with explosives.

Breakers or busters—for breaking and chipping rock or loosening hard compact earth.

Air riveters (guns)—for driving rivets in steel bridge and building construction.

Plug drills—for plug and feather work, used generally in quarries for dimension stone such as granite, sandstone, and marble.

Air augers—for drilling holes in wood, in use on wooden piers, cofferdams, roof trusses, etc.

Bolt runners—for tightening bolts.

Tampers—to consolidate backfill.

Hoists, single and multiple drum—for use with derricks, mine scrapers, car haulage in industrial plants, etc.

Sheathing hammers—in trenches or cofferdams to drive wood sheathing, usually up to about 3 in. thick.

Air spades—for digging hard clay or other compact material.

Air vibrators—for concrete.

Pile hammers—for driving any type of pile.

Air saws, air clamps, etc.

The above tools use a varying amount of air, depending on size, mechanical condition of tool, etc.

For tools in general use on a construction job, such as a drill, breaker, tamper, and spades, a figure of 50 cu. ft. can be taken to estimate the compressor capacity required.

For example, a 210 cu. ft. compressor will operate four average size



drills, breakers, spades, or tampers, assuming that these tools are in fair mechanical condition.

The above figure is for practical field conditions.

Two or more compressors may be coupled together to increase the available amount of air. If this is done, the compressors should discharge into an air receiver or reservoir. This will increase efficiency, decrease wear on compressors, and insure an even flow of power to tools.

On any job it is good practice to have one spare tool for every four tools in use to avoid costly delays caused by mechanical failure.

Tools are expensive and should be well cared for; carelessness is an item that should not be on any report sheet.

Some attempts have been made to operate percussion tools (breakers) by gasoline or electricity, but this type of tool is not in general use as yet in the construction field.

Careful consideration should be given to weight of tool selected for various operations. For instance, a man can use a heavier, more powerful drill or breaker if he is drilling a down hole, i.e., a hole either vertical or on a slant away from him. But a much lighter tool should be provided for drilling or chipping a horizontal hole (breast hole), to avoid excessive fatigue. There is, however, a third leg or jack on the market which can be clamped to the drill or breaker which will relieve the operator of much of the weight of the tool and which adds considerably to the efficiency of the tool.

An air tool in operation is always cold owing to the expansion of the air out of the exhaust valve; hence, care must be taken to use a good grade of air oil for lubrication. One of the best of many ways to oil an air tool is by a line oiler. This is an oil reservoir holding about a pint of oil and can be set to provide oil drop by drop into the air line which is carried to the tool.

For several years manufacturers have provided a drill rod threaded on one end to receive a jack bit. This eliminates hand sharpening of steel on the job as the jack bit can be used until dull or until the gage is worn down, then it is simply unscrewed from the rod and replaced.

The gage of a bit is its width. As the drill rotates, the bit is worn down by the rock and gradually the bit becomes narrower until finally, in construction parlance, "the gage is gone."

The gage of a bit is of great importance. Drill rods usually provide for a depth of hole up to 10 ft. to 12 ft. or more by 2-ft. stages.

**EXAMPLE.**

**GAGE**

No. 1 or starter drill rod 2 ft.—Bit 2 in.

No. 2 drill rod 4 ft.—Bit 1¾ in.

No. 3 drill rod 6 ft.—Bit 1½ in.

Note that, on No. 1 bit, the gage is 2 in.

As the bit is worn or loses its gage, it is evident that No. 2 bit will not follow; that is, it will not seat at the bottom of the hole already drilled by No. 1. As a result, bit 2 will become fast in the hole resulting in loss of steel and time. The above bit sizes are arbitrary, but note that the gage for any following bit is  $\frac{1}{4}$  in. smaller always.

Bits may be resharpened by special tools but always to a smaller gage; for example a 2-in. bit becomes  $1\frac{3}{4}$  in., etc.

Bits are various shapes: X bits, cross bits + or six point or rose bits . The cross bit and six point are the more common. Although each shape has its strong supporters among rock men, in general it can be said that, in hard dense rock, the cross bit is superior, while in loosely stratified rock, the six point is superior. The six point bit is especially desirable in drilling concrete for demolition.

The use of goggles to protect the eyes is a wise precaution for men operating drills or breakers, and in enclosed places a simple dust mask can be provided to keep the nose and throat as free from dust as possible.

Electric tools such as saws, pumps, wood augers, vibrators, bolt runners, and drill presses have a place in construction. For many tools, electricity is more advantageous in that the primary power feeder is a distant power house and, after the feeder lines are run, power is available at the turn of a switch.

Gasoline- and diesel-fuel-driven motors are widely used as the primary power unit on all sizes of tools from the small compressor, table saws, pumps, vibrators, chain saws, electric generators, etc., to the giant locomotive.



# PART II

## SURVEYING

### TOPOGRAPHIC SURVEY

Traverse points should be selected with a view to economy of setups; e.g., so located that a maximum area can be seen by the instrument man. For accuracy the traverse should be run separately from the topography shots. For economy, where refined accuracy is not necessary, the traverse and the topography can be run simultaneously; i.e., the topography shots are taken as each traverse point is occupied.

Since stadia topography is normally plotted with a protractor, refinements greater than 15 minutes in the horizontal angle are not warranted. Considerable speed is attained when the horizontal angles are estimated to the nearest quarter degree and the vertical angles to the nearest minute.

#### SAMPLE NOTES

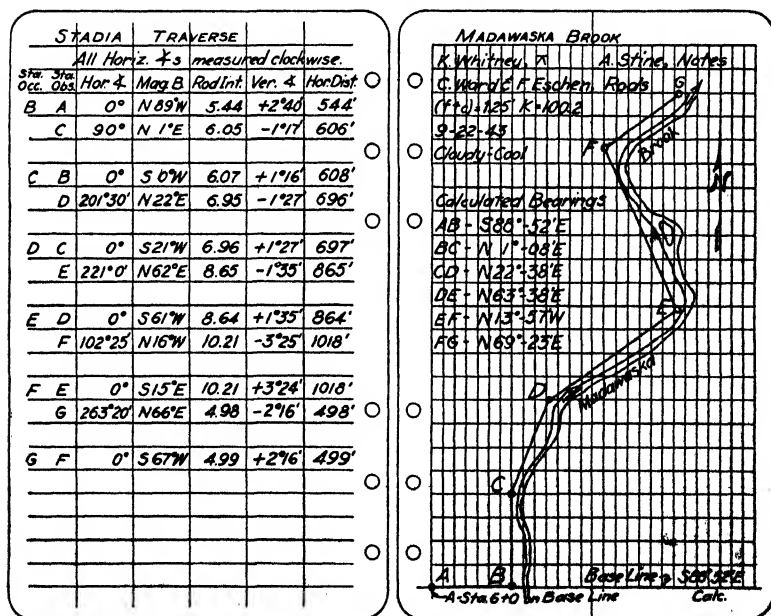

Fig. 1.

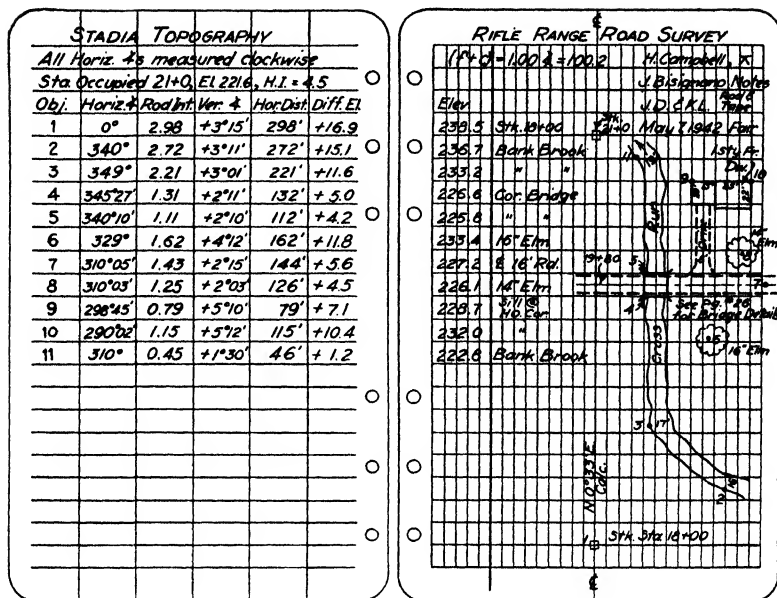

Fig. 2.

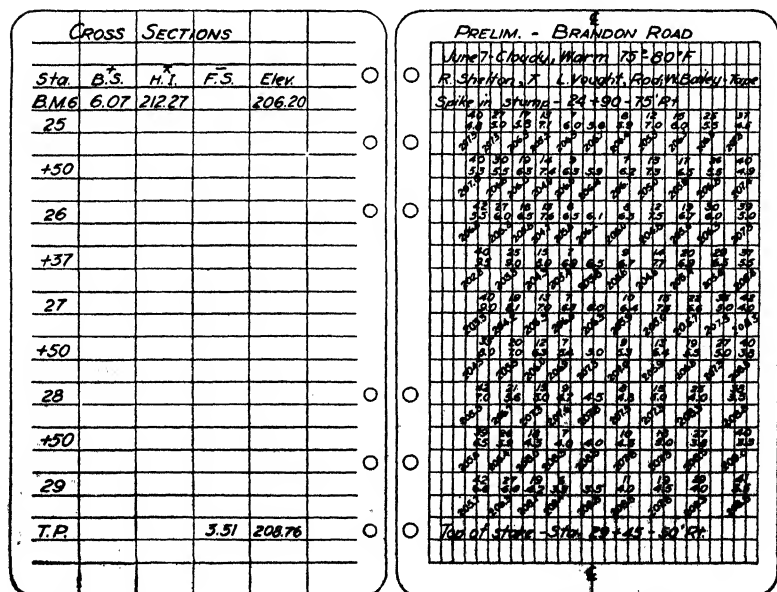

Fig. 3.

## STADIA TABLES

### Table 1. Stadia Reductions \*

Differences in Elevation for 100 ft. Inclined Distance

Min- utes	0°	1°	2°	3°	4°	5°	6°	7°	8°	9°	10°	11°	12°
0	0.00	1.74	3.49	5.23	6.96	8.68	10.40	12.10	13.78	15.45	17.10	18.73	20.34
2	0.06	1.80	3.55	5.28	7.02	8.74	10.45	12.15	13.84	15.51	17.16	18.78	20.39
4	0.12	1.86	3.60	5.34	7.07	8.80	10.51	12.21	13.89	15.56	17.21	18.84	20.44
6	0.17	1.92	3.66	5.40	7.13	8.85	10.57	12.26	13.95	15.62	17.26	18.89	20.50
8	0.23	1.98	3.72	5.46	7.19	8.91	10.62	12.32	14.01	15.67	17.32	18.95	20.55
10	0.29	2.04	3.78	5.52	7.25	8.97	10.68	12.38	14.06	15.73	17.37	19.00	20.60
12	0.35	2.09	3.84	5.57	7.30	9.03	10.74	12.43	14.12	15.78	17.43	19.05	20.66
14	0.41	2.15	3.90	5.63	7.36	9.08	10.79	12.49	14.17	15.84	17.48	19.11	20.71
16	0.47	2.21	3.95	5.69	7.42	9.14	10.85	12.55	14.23	15.89	17.54	19.16	20.76
18	0.52	2.27	4.01	5.75	7.48	9.20	10.91	12.60	14.28	15.95	17.59	19.21	20.81
20	0.58	2.33	4.07	5.80	7.53	9.25	10.96	12.66	14.34	16.00	17.65	19.27	20.87
22	0.64	2.38	4.13	5.86	7.59	9.31	11.02	12.72	14.40	16.06	17.70	19.32	20.92
24	0.70	2.44	4.18	5.92	7.65	9.37	11.08	12.77	14.45	16.11	17.76	19.38	20.97
26	0.76	2.50	4.24	5.98	7.71	9.43	11.13	12.83	14.51	16.17	17.81	19.43	21.03
28	0.81	2.56	4.30	6.04	7.76	9.48	11.19	12.88	14.56	16.22	17.86	19.48	21.08
30	0.87	2.62	4.36	6.09	7.82	9.54	11.25	12.94	14.62	16.28	17.92	19.54	21.13
32	0.93	2.67	4.42	6.15	7.88	9.60	11.30	13.00	14.67	16.33	17.97	19.59	21.18
34	0.99	2.73	4.48	6.21	7.94	9.65	11.36	13.05	14.73	16.39	18.03	19.64	21.24
36	1.05	2.79	4.53	6.27	7.99	9.71	11.42	13.11	14.79	16.44	18.08	19.70	21.29
38	1.11	2.85	4.59	6.33	8.05	9.77	11.47	13.17	14.84	16.50	18.14	19.75	21.34
40	1.16	2.91	4.65	6.38	8.11	9.83	11.53	13.22	14.90	16.55	18.19	19.80	21.39
42	1.22	2.97	4.71	6.44	8.17	9.88	11.59	13.28	14.95	16.61	18.24	19.86	21.45
44	1.28	3.02	4.76	6.50	8.22	9.94	11.64	13.33	15.01	16.66	18.30	19.91	21.50
46	1.34	3.08	4.82	6.56	8.28	10.00	11.70	13.39	15.06	16.72	18.35	19.96	21.55
48	1.40	3.14	4.88	6.61	8.34	10.05	11.76	13.45	15.12	16.77	18.41	20.02	21.60
50	1.45	3.20	4.94	6.67	8.40	10.11	11.81	13.50	15.17	16.83	18.46	20.07	21.66
52	1.51	3.26	4.99	6.73	8.45	10.17	11.87	13.56	15.23	16.88	18.51	20.12	21.71
54	1.57	3.31	5.05	6.79	8.51	10.22	11.93	13.61	15.28	16.94	18.57	20.18	21.76
56	1.63	3.37	5.11	6.84	8.57	10.28	11.98	13.67	15.34	16.99	18.62	20.23	21.81
58	1.69	3.43	5.17	6.90	8.63	10.34	12.04	13.73	15.40	17.05	18.68	20.28	21.87
60	1.74	3.49	5.23	6.96	8.68	10.40	12.10	13.78	15.45	17.10	18.73	20.34	21.92
<i>f + c</i>													
0.75	0.01	0.02	0.03	0.05	0.06	0.07	0.08	0.10	0.11	0.12	0.14	0.15	0.16
1.00	0.01	0.03	0.04	0.06	0.08	0.09	0.11	0.13	0.15	0.16	0.18	0.20	0.22
1.25	0.02	0.03	0.05	0.08	0.10	0.11	0.14	0.16	0.18	0.21	0.23	0.25	0.27

### Corrections to Horizontal Distances

Min- utes	0°	1°	2°	3°	4°	5°	6°	7°	8°	9°	10°	11°	12°
0	.....	0.03	0.12	0.27	0.49	0.76	1.09	1.49	1.94	2.45	3.02	3.64	4.32
10	.....	0.04	0.14	0.31	0.53	0.81	1.15	1.56	2.02	2.54	3.12	3.75	4.44
20	.....	0.05	0.17	0.34	0.57	0.86	1.22	1.63	2.10	2.63	3.22	3.86	4.56
30	0.01	0.07	0.19	0.37	0.62	0.92	1.28	1.70	2.18	2.72	3.32	3.97	4.68
40	0.01	0.08	0.22	0.41	0.66	0.98	1.35	1.78	2.27	2.82	3.42	4.09	4.81
50	0.02	0.10	0.24	0.45	0.71	1.03	1.42	1.86	2.36	2.92	3.53	4.21	4.93

Table 1. Stadia Reductions (Continued) \*

Differences in Elevation for 100 ft. Inclined Distance

Minutes	13°	14°	15°	16°	17°	18°	19°	20°	21°	22°	23°	24°	25°
0	21.92	23.47	25.00	26.50	27.96	29.39	30.78	32.14	33.46	34.73	35.97	37.16	38.30
2	21.97	23.52	25.05	26.55	28.01	29.44	30.83	32.18	33.50	34.77	36.01	37.20	38.34
4	22.02	23.58	25.10	26.59	28.06	29.48	30.87	32.23	33.54	34.82	36.05	37.23	38.38
6	22.08	23.63	25.15	26.64	28.10	29.53	30.92	32.27	33.59	34.86	36.09	37.27	38.41
8	22.13	23.68	25.20	26.69	28.15	29.58	30.97	32.32	33.63	34.90	36.13	37.31	38.45
10	22.18	23.73	25.25	26.74	28.20	29.62	31.01	32.36	33.67	34.94	36.17	37.35	38.49
12	22.23	23.78	25.30	26.79	28.25	29.67	31.06	32.41	33.72	34.98	36.21	37.39	38.53
14	22.28	23.83	25.35	26.84	28.30	29.72	31.10	32.45	33.76	35.02	36.25	37.43	38.56
16	22.34	23.88	25.40	26.89	28.34	29.76	31.15	32.49	33.80	35.07	36.29	37.47	38.60
18	22.39	23.93	25.45	26.94	28.39	29.81	31.19	32.54	33.84	35.11	36.33	37.51	38.64
20	22.44	23.99	25.50	26.99	28.44	29.86	31.24	32.58	33.89	35.15	36.37	37.54	38.67
22	22.49	24.04	25.55	27.04	28.49	29.90	31.28	32.63	33.93	35.19	36.41	37.58	38.71
24	22.54	24.09	25.60	27.09	28.54	29.95	31.33	32.67	33.97	35.23	36.45	37.62	38.75
26	22.60	24.14	25.65	27.13	28.58	30.00	31.38	32.72	34.01	35.27	36.49	37.66	38.78
28	22.65	24.19	25.70	27.18	28.63	30.04	31.42	32.76	34.06	35.31	36.53	37.70	38.82
30	22.70	24.24	25.75	27.23	28.68	30.09	31.47	32.80	34.10	35.36	36.57	37.74	38.86
32	22.75	24.29	25.80	27.28	28.73	30.14	31.51	32.85	34.14	35.40	36.61	37.77	38.89
34	22.80	24.34	25.85	27.33	28.77	30.19	31.56	32.89	34.18	35.44	36.65	37.81	38.93
36	22.85	24.39	25.90	27.38	28.82	30.23	31.60	32.93	34.23	35.48	36.69	37.85	38.97
38	22.91	24.44	25.95	27.43	28.87	30.28	31.65	32.98	34.27	35.52	36.73	37.89	39.00
40	22.96	24.49	26.00	27.48	28.92	30.32	31.69	33.02	34.31	35.56	36.77	37.93	39.04
42	23.01	24.55	26.05	27.52	28.96	30.37	31.74	33.07	34.35	35.60	36.80	37.96	39.08
44	23.06	24.60	26.10	27.57	29.01	30.41	31.78	33.11	34.40	35.64	36.84	38.00	39.11
46	23.11	24.65	26.15	27.62	29.06	30.46	31.83	33.15	34.44	35.68	36.88	38.04	39.15
48	23.16	24.70	26.20	27.67	29.11	30.51	31.87	33.20	34.48	35.72	36.92	38.08	39.18
50	23.22	24.75	26.25	27.72	29.15	30.55	31.92	33.24	34.52	35.76	36.96	38.11	39.22
52	23.27	24.80	26.30	27.77	29.20	30.60	31.96	33.28	34.57	35.80	37.00	38.15	39.26
54	23.32	24.85	26.35	27.81	29.25	30.65	32.01	33.33	34.61	35.85	37.04	38.19	39.29
56	23.37	24.90	26.40	27.86	29.30	30.69	32.05	33.37	34.65	35.89	37.08	38.23	39.33
58	23.42	24.95	26.45	27.91	29.34	30.74	32.09	33.41	34.69	35.93	37.12	38.26	39.36
60	23.47	25.00	26.50	27.96	29.39	30.78	32.14	33.46	34.73	35.97	37.16	38.30	39.40
$f+c$													
.75	0.17	0.19	0.20	0.21	0.23	0.24	0.25	0.26	0.27	0.29	0.30	0.31	0.32
1.00	0.23	0.25	0.27	0.28	0.30	0.32	0.33	0.35	0.37	0.38	0.40	0.41	0.43
1.25	0.29	0.31	0.34	0.36	0.38	0.40	0.42	0.44	0.46	0.48	0.50	0.52	0.54

## Corrections to Horizontal Distances

Minutes	13°	14°	15°	16°	17°	18°	19°	20°	21°	22°	23°	24°	25°
0	5.06	5.85	6.70	7.60	8.55	9.55	10.60	11.70	12.84	14.03	15.27	16.54	17.86
10	5.19	5.99	6.84	7.75	8.71	9.72	10.78	11.89	13.04	14.24	15.48	16.76	18.08
20	5.32	6.13	6.99	7.91	8.88	9.89	10.96	12.07	13.23	14.44	15.69	16.98	18.31
30	5.45	6.27	7.14	8.07	9.04	10.07	11.14	12.26	13.43	14.64	15.90	17.20	18.53
40	5.58	6.41	7.29	8.23	9.21	10.24	11.33	12.46	13.63	14.85	16.11	17.42	18.76
50	5.72	6.55	7.44	8.39	9.38	10.42	11.51	12.65	13.83	15.06	16.33	17.64	18.99

\* From Eshbach, *Handbook of Engineering Fundamentals*, John Wiley & Sons, 1936.

## CONSTRUCTION STAKEOUTS

### STAKEOUT FOR STRUCTURES

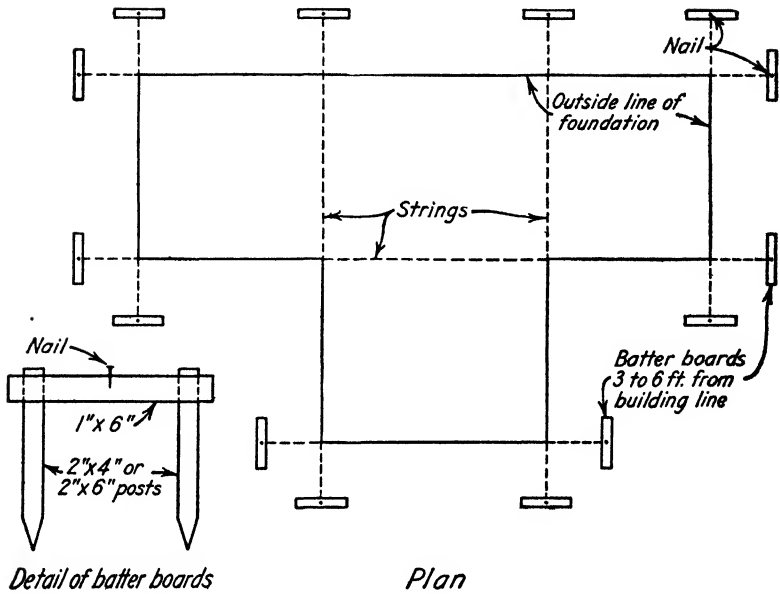

FIG. 4. Batter boards for structures.

Batter boards as illustrated are set on, or parallel to, the building or structure lines either before or after the rough excavation is completed. When set before excavating, the batter boards should be checked upon completion of the rough excavation. Points on the batter boards may be set on the outside foundation line or sometimes on the center line of columns. It is preferable to set the top of each batter board to some definite grade, such as the first-floor elevation or else some even foot above or below a working grade.

Before setting the batter boards a base line should be established and referenced in with ties. Targets may also be set on the base line projected. Angles turned from the base line should be established by the method of repetition (see p. 244) as an error of 1 minute in 300 ft. will throw the building line off 1 in.

From time to time during construction, the batter boards should be checked for disturbance or movement.



## HIGHWAY CONSTRUCTION STAKEOUT

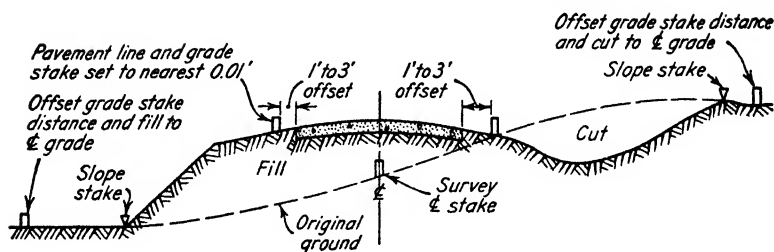

FIG. 5. Highway construction stakeout.

Before work begins, the construction centerline is staked out, usually on 50-ft. stations. Hubs are set at P.C.'s, P.T.'s, P.I.'s, and transit points. These hubs are tied in or offset, and the ties are recorded in the field book.

Offset grade stakes are set on 50-ft. stations far enough out to escape disturbance during operations where possible. Elevations of these stake tops are taken with a level, and the cut or fill to finish center-line grade is computed and marked on each stake. The distance to the toe or top of slope is marked on the offset grade stake or else the actual location of the toe or top of slope is marked with a slope stake. The station and the distance from the offset stake to center line are marked on the face of the offset stake. The superelevation plus or minus to edge of pavement and any pavement widening or curves are also marked on the offset stakes.

After rough grading is completed, blue tops or fine grade stakes are set every 50 ft. minimum. Blue tops are stakes set to fine grade and the top marked blue. Allowance for settlement or subsidence is sometimes made in setting these grades, or it may be made the contractor's responsibility, the engineer in the latter case setting the stakes to the grades shown on plan.

For concrete pavement, stakes are set usually every 50 ft. on tangents and straight grades and every 25 ft. on horizontal and vertical curves. These stakes are carefully aligned with a transit and tacks set on line. Either the tops are set to exact grade or the cut or fill is marked to finish grade.

Pavement stakes are set with a sufficient offset to allow room for the flanged bases of the forms, the offset usually being about 18 in. or 2 ft. from the edge of pavement. After the initial lane is placed, additional stakes may be set for other lanes or the forms may be set by leveling over with a line level.

For asphaltic pavements stakes are usually not set when the base has been constructed true to grade as the paving machines can be set for the required thickness. If the base is variable, steel pins for line and grade are usually set at 50- or 25-ft. intervals and offset enough to allow the machines to work. A 1-ft. offset is usually sufficient.

The amount of stakeout done for highway construction depends on the value and importance of the work, and judgment is required. For example, on cheap tertiary road construction only center-line stakes might be set at 100-ft. stations and a list of cuts and fill given to the foreman. The line and grade may then be transferred by the foreman, using a tape and hand level, to convenient trees, offset stakes, etc.

Through wooded country, stakes or marks are usually set at the clearing and grubbing limits. Trees to be saved are indicated by markings or signs.

In addition to line and grade stakes, right-of-way stakes may be necessary, also project markers and stakes set at intersection of right-of-way and adjoining property lines.

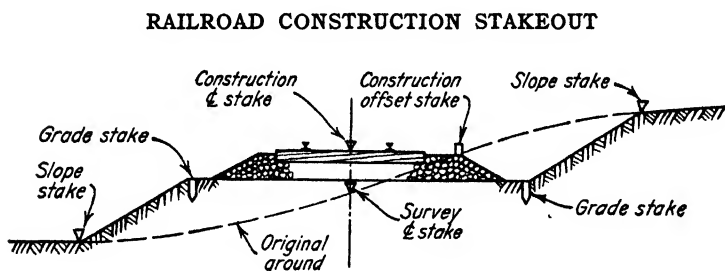

FIG. 6. Railroad construction stakeout.

Stakeout for the grading work is similar to highway stakeout.

After grading is finished, and the ballast, ties, and rails are being installed, stakes for exact alignment and grade of rails are set. These stakes are tacked for line and may be set on center line or offset about 2 ft. from one rail. The grade marked is usually finish grade to the near rail, super-elevation being set for the other rail by using a track level.

## AIRFIELD CONSTRUCTION STAKEOUT

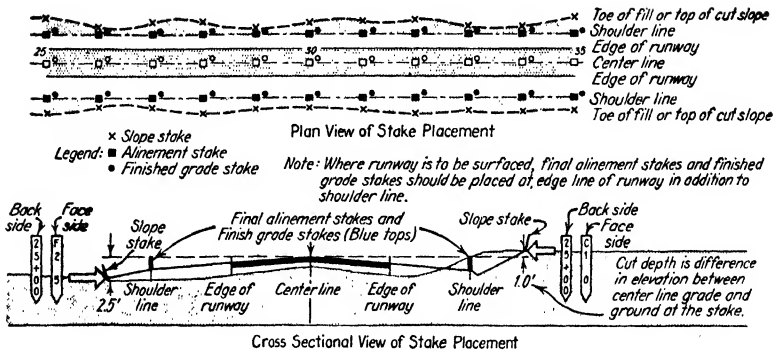

FIG. 7. Airport stakeout.

The stakeout required differs from highway work in that the widths of runways and taxiways, together with their shoulders and graded areas, are so great that it is not practicable to set offset stakes to serve during construction.

The construction center line is staked out at 50-ft. stations and well referenced and tied in, and targets are set on the line extended. During grading operations stakes are set continually day by day, at least one party usually being required at all times for each runway under construction.

For rough grading stakes at 50-ft. intervals both longitudinally and transversely are sufficient, but for fine grading stakes should be set at 25-ft. intervals.

Concrete pavement stakes are set exactly the same as for highways, but owing to the widths of runways and aprons it is not desirable to depend on a string level to transfer the grades for more than 2 or 3 lanes. Additional stake lines should be run in at intervals of 25 or 30 ft. transversely.

Stakeout for asphaltic pavements is the same as for highways.

Stakes for grading interior areas are usually set on 50- to 100-ft. grids and marked for cut and fill.

## PIPELINE STAKEOUT \*

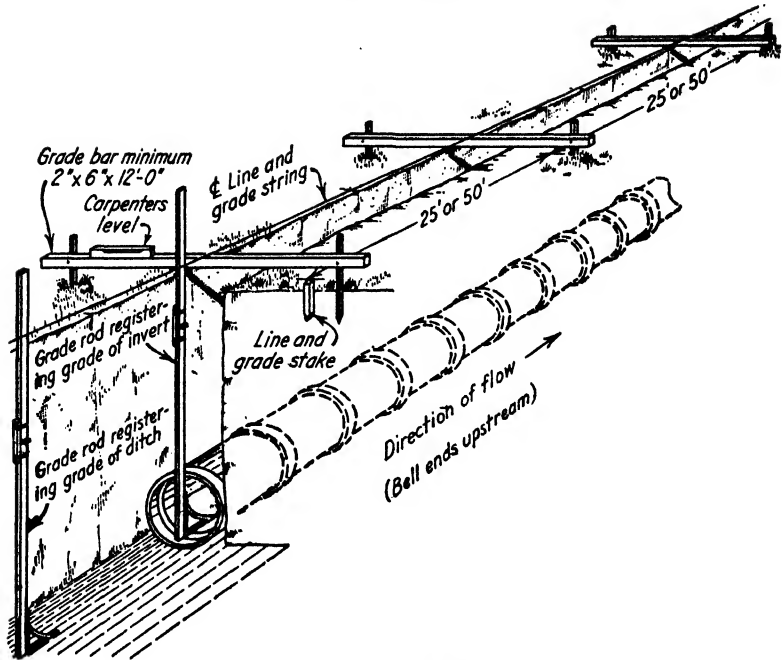

FIG. 8. Pipeline stakeout.

Before beginning excavation, stakes should be set 25 or 50 ft. apart parallel to and offset from the center line of the drain on the side opposite to that on which earth will be thrown. Elevations of tops of stakes should be taken with a level and depth of cut marked on each. These stakes will serve as guides for the rough excavation.

Excavation should be begun at the outlet.

After the excavation is approximately to grade, batter boards should be placed across the trench opposite each stake with the top of each board at the same distance above the grade of the flow line. About 6.5 or 7 ft. above grade is good practice. The center line is then marked on the batter boards, and a string connecting these points will be directly above and parallel to the grade line. The center line at any point may then be obtained by dropping a plumb bob from the string, and the grade determined by measuring down from the string with a pole of proper length.

Laying of pipe should begin at the outlet and proceed upstream.

\* *From Principles of Highway Construction Applied to Airports, Flight Strips and other Landing Areas for Aircraft, Public Roads Administration.*

## CIRCULAR CURVES

### ARC DEFINITION

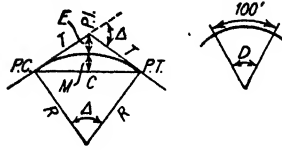

#### FORMULAS

$$R = \frac{5729.58}{D}$$

$$T = R \tan \frac{\Delta}{2}; \quad T = \frac{\tan 1^\circ \text{ curve for } \Delta}{D}$$

$$L = \text{length} = \frac{100\Delta}{D}$$

$$M = R(1 - \cos \frac{1}{2}\Delta)$$

$$E = R \left( \frac{1}{\cos \frac{1}{2}\Delta} - 1 \right); \quad E = \frac{\text{ext. } 1^\circ \text{ curve for } \Delta}{D}$$

$$C = 2R \sin \frac{\Delta}{2}$$

#### DEFINITIONS

$L$  = Length of circular curve.

P.I. = point of intersection.

P.C. = point of curvature.

P.T. = point of tangency.

**EXAMPLE.** Given.  $\Delta = 54^\circ 20'$ ;  $D = 7^\circ 40'$ ; P.I. = Sta. 125 + 39.88.

**Required.**  $R$ ;  $T$ ;  $L$  and Sta. of P.C. and P.T.

**Solution.**

$$R = \frac{5729.58}{7^\circ 40'} = 747.34'$$

$$T = 747.34 (\tan 27^\circ 10') = 747.34(0.513195) = 383.53'$$

Also, from p. 208 (funct.  $1^\circ$  curve) by interpolation,  $\tan 1^\circ$  curve for  $\Delta 54^\circ 20' = 2940.41$ .

$$\therefore T = \frac{2940.41}{7^\circ 40'} = 383.53'$$

$$\text{P.C.} = \text{Sta. } 125 + 39.88 - 383.53 = \text{Sta. } 121 + 56.35.$$

$$L = \frac{100\Delta}{D} = \frac{100(54^\circ 20')}{7^\circ 40'} = 708.70'$$

$$\text{P.T.} = \text{Sta. } 121 + 56.35 + 708.70 = \text{Sta. } 128 + 65.05.$$

## DEFLECTIONS

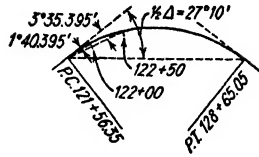

### FORMULAS

Deflection angle =  $\frac{D}{2}$  for 100';  $\frac{D}{4}$  for 50', etc.

For  $c$  feet (in minutes) =  $0.3 cD$ .

Deflection angle (in minutes) from P.C. to P.T. =  $0.3LD$ .

Also, deflection angle (in degrees) from P.C. to P.T. =  $\frac{\Delta}{2}$ .

**EXAMPLE.** Given.  $\Delta = 54^\circ 20'$ ;  $D = 7^\circ 40'$ ;  $L = 708.70$ ; P.C. = Sta. 121 + 56.35; P.T. = Sta. 128 + 65.05.

**Required.** Deflection angle from P.C. to Sta. 122 + 00; Sta. 122 + 50 and P.T. Sta. 128 + 65.05.

**Solution.**

Sta. 122 + 00 - P.C. Sta. 121 + 56.35 = 43.65'.

$\therefore$  Deflection angle to Sta. 122 + 00 =  $0.3 \times 43.65 \times 7^\circ 40' = 100.395'$   
 =  $1^\circ 40.395'$ .

Deflection angle to Sta. 122 + 50 =  $1^\circ 40.395' + \frac{7^\circ 40'}{4} = 1^\circ 40.395'$   
 +  $1^\circ 55' = 3^\circ 35.395'$ .

Deflection angle to P.T. Sta. 128 + 65.05 =  $0.3 \times 708.70 \times 7^\circ 40'$   
 =  $27^\circ 10'$ .

Also, deflection angle to P.T. Sta. 128 + 65.05 =  $\frac{\Delta}{2} = \frac{54^\circ 20'}{2}$   
 =  $27^\circ 10'$ .

## EXTERNALS



**EXAMPLE.** Given.  $\Delta = 54^\circ 20'$ ;  $D = 7^\circ 40'$ ;  $R = 747.34'$ .

**Required.** External "E".

**Solution.**

$$E = 747.34 \left( \frac{1}{.8896822} - 1 \right) = 92.67'.$$

Also, from p. 208 (func.  $1^\circ$  curve) by interpolation, external  $1^\circ$  curve for  $\Delta 54^\circ 20' = 710.48$ .

$$\therefore E = \frac{710.48}{7^\circ 40'} = 92.67'.$$

## MINIMUM CURVATURE \*

The curve should be at least 500 ft. long for  $\Delta = 5$  degrees and increase 100 ft. in length for each decrease of 1 degree in the  $\Delta$ .

Where topography permits, use simple  $0^\circ 20'$  to  $1^\circ 00'$  curves without superelevation or widening.

## MAXIMUM CURVATURE \*

ASSUMED DESIGN SPEED, M.P.H.	DEGREE OF CURVE	
	DESIRABLE MAXIMUM	ABSOLUTE MAXIMUM
30	20	25
40	11	14
50	7	9
60	5	6
70	3	4

## TANGENT OFFSETS

The approximate offset from the tangent to the curve at any distance from the P.C. =  $\frac{\text{distance}^2}{2R}$ .

## CHORD DEFINITION (R. R. CURVE)

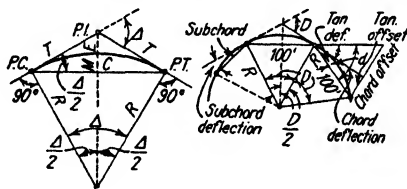

$D$  (in degrees) subtends 100' chord.

$$D = 100 \Delta / L$$

$$D = \frac{\tan 1^\circ \text{ curve}}{T} \text{ (approx.)}$$

$$D = \frac{\text{ext. } 1^\circ \text{ curve}}{E} \text{ (approx.)}$$

$$\text{Tan offset} = \frac{\text{chord}^2}{2R} = \text{chord} \cdot \sin \text{ def.} = \left( \frac{\text{chord}^2}{100} \right) \text{tan offset, Table 3.}$$

$$\text{Chord offset} = 2 \text{tan deflection for } 100' \text{ chord} = 100 \sin D^\circ.$$

\* From Geometric Design Standards by A.A.S.H.O.

Tan def. =  $\frac{1}{2}D \frac{\text{chord}}{100}$ ; for  $c$  feet =  $0.3D \times c = \text{def. for } 1' \text{ in Table 2}$

$\times c.$

Chord def. =  $2 \tan \text{def.} = D$  for 100' chord.

FORMULAS

$$R = \frac{50}{\sin D/2}; \quad R = T \cdot \cotan \frac{\Delta}{2}; \quad R = \frac{E}{\text{exsec } \Delta/2}; \quad T = R \cdot \tan \frac{\Delta}{2};$$

$$T = \frac{50 \tan \Delta/2}{\sin \Delta/2}; \quad T = \frac{\tan 1^\circ \text{ curve}}{D} + \text{corr.}^* \quad L = 100 \frac{\Delta}{D}; \quad \Delta = \frac{DL}{100};$$

$$M = R \left( 1 - \cos \frac{\Delta}{2} \right); \quad M = R \text{ vers } \frac{\Delta}{2}; \quad E = T \cdot \tan \frac{\Delta}{4};$$

$$E = \frac{R}{\cos \Delta/2} - R; \quad E = R \cdot \text{exsec } \frac{\Delta}{2}. \quad C = 2R \cdot \sin \frac{\Delta}{2};$$

$$E = \frac{\text{ext. } 1^\circ \text{ curve}}{D} + \text{correction.}^* \quad \sin \frac{D}{2} = \frac{50}{R}; \quad \sin \frac{D}{2} = \frac{50 \tan \Delta/2}{T}$$

EXAMPLE. Given.  $\Delta = 54^\circ 20'$ ;  $D = 7^\circ 40'$ , P.I. Sta. 125 + 39.88.

Required.  $R, T, L, \text{P.C.},$  and  $\text{P.T.}$

Solution.

$$R = 50 \div \sin 3^\circ 50' = 747.89.$$

$$T = 747.89 (\tan 27^\circ 10') = 383.81.$$

$$L = 100\Delta \div D = 100 (54^\circ 20') \div 7^\circ 40' = 708.70.$$

$$\text{P.C.} = \text{P.I. Sta. } 125 + 39.88 - 383.81 = \text{Sta. } 121 + 56.07.$$

$$\text{P.T.} = \text{Sta. } 121 + 56.07 + 708.70 = \text{Sta. } 128 + 64.77.$$

\* See p. 209.



CIRCULAR CURVES

TABLE 2. RADII, DEFLECTIONS, OFFSETS, ORDINATES, CHORDS AND ARCS—100' CHORDS \*

D	Radius	Def. for 1 Ft.	Tan Off-set	Mid Ord.	For Subchords Add				Actual Arc per 100' Sta.	Long Chords				D
					10'	20'	25'	50'		2 Sta.	3 Sta.	4 Sta.	5 Sta.	
30'	11,459.2	0.15	0.436	0.109				100.000	200.000	299.99	399.98	499.96	30'	
1°	5,729.65	0.30	0.873	0.218				100.001	199.99	299.97	399.92	499.85	1°	
30'	3,819.83	0.45	1.309	0.327				100.003	199.98	299.93	399.83	499.66	30'	
2°	2,864.93	0.60	1.745	0.436				100.005	199.97	299.88	399.70	499.39	2°	
30'	2,292.01	0.75	2.181	0.545				100.008	199.95	299.81	399.52	499.05	30'	
3°	1,910.08	0.90	2.618	0.654				100.011	199.93	299.73	399.32	498.63	3°	
30'	1,637.28	1.05	3.054	0.764				100.015	199.91	299.63	399.07	498.14	30'	
4°	1,432.69	1.20	3.490	0.872			0.01	100.020	199.88	299.51	398.78	497.57	4°	
30'	1,273.57	1.35	3.926	0.982			0.01	100.026	199.85	299.38	398.46	496.92	30'	
5°	1,146.28	1.50	4.362	1.091			0.01	100.032	199.81	299.24	398.10	496.20	5°	
30'	1,042.14	1.65	4.798	1.200			0.01	100.038	199.77	299.08	397.70	495.41	30'	
6°	955.37	1.80	5.234	1.309		0.01	0.01	100.046	199.73	298.90	397.26	494.53	6°	
30'	881.95	1.95	5.669	1.418		0.01	0.01	100.054	199.68	298.71	396.79	493.59	30'	
7°	819.02	2.10	6.105	1.528		0.01	0.01	100.062	199.63	298.51	396.28	492.57	7°	
8°	716.78	2.40	6.976	1.746		0.01	0.02	100.081	199.51	298.05	395.14	490.31	8°	
10°	573.69	3.00	8.716	2.183		0.01	0.02	100.127	199.24	296.96	392.42	484.90	10°	
12°	478.34	3.60	10.45	2.620		0.02	0.04	100.183	198.90	295.63	389.12	478.34	12°	
14°	410.28	4.20	12.18	3.058		0.02	0.05	100.249	198.51	294.06	385.23	470.65	14°	
16°	359.27	4.80	13.92	3.496		0.03	0.06	100.326	198.05	292.25	380.76	461.86	16°	
18°	319.62	5.40	15.64	3.935		0.04	0.08	100.412	197.54	290.21	375.74	452.02	18°	
20°	287.94	6.00	17.37	4.374		0.05	0.10	100.510	196.96	287.94	370.17	441.15	20°	
22°	262.04	6.60	19.08	4.814		0.06	0.12	100.617	196.33	285.44	364.06	429.31	22°	
24°	240.49	7.20	20.79	5.255		0.07	0.14	100.735	195.63	282.71	357.43	416.54	24°	
30°	193.18	9.00	25.88	6.583		0.11	0.22	101.152	193.19	273.21	334.61	373.21	30°	

\* Adapted from Railroad Curve Tables by Eugene Dietzgen Co.

**TABLE 3. MINUTES IN DECIMALS OF A DEGREE,  
SECONDS IN DECIMALS OF A MINUTE \***

1	0.0167	11	0.1833	21	0.3500	31	0.5167	41	0.6833	51	0.8500
2	0.0333	12	0.2000	22	0.3667	32	0.5333	42	0.7000	52	0.8667
3	0.0500	13	0.2167	23	0.3833	33	0.5500	43	0.7167	53	0.8833
4	0.0667	14	0.2333	24	0.4000	34	0.5667	44	0.7333	54	0.9000
5	0.0833	15	0.2500	25	0.4167	35	0.5833	45	0.7500	55	0.9167
6	0.1000	16	0.2667	26	0.4333	36	0.6000	46	0.7667	56	0.9333
7	0.1167	17	0.2833	27	0.4500	37	0.6167	47	0.7833	57	0.9500
8	0.1333	18	0.3000	28	0.4667	38	0.6333	48	0.8000	58	0.9667
9	0.1500	19	0.3167	29	0.4833	39	0.6500	49	0.8167	59	0.9833
10	0.1667	20	0.3333	30	0.5000	40	0.6667	50	0.8333	60	1.0000

Proportional Part for 1" = 0.000278 of 1°

USE OF TABLES 2 AND 3

Given	Required	Solution	
$D = 2^\circ 30'$	Deflection for 35 ft.	$= 0.75 \times 35 = 26.25$	$= 26' 15''$
$D = 4^\circ$	Tan offset for 125 ft.	$= 3.49(1.25/100)^2$	$= 5.45$ ft.
$D = 10^\circ$	Mid ord. for 30 ft. chord	$= 0.0001 \times 30^2 \times 2.183$	$= 0.196$ ft.
$D = 14^\circ$	Length of nominal 20 ft. sub chord	$= 20 + 0.05$	$= 20.05$ ft.
$D = 20^\circ$	Actual length of arc for $L = 600$ ft. (6 Sta.)	$= 100.51 \times 6$	$= 603.06$ ft.
$D = 3^\circ$	Long chord for 3 Sta.	$=$ From Table 2	$= 299.73$ ft.
$\Delta = 27^\circ 05' 11''$	$\Delta$ in decimals of °	$=$ From Table 3 $= 27 + 0.0833 + 11 \times 0.000278$	$= 27.086^\circ$

\* Adapted from Railroad Curve Tables by Eugene Dietzgen Co.

TABLE 4. FUNCTIONS OF 1° CURVE

See pp. 202, 203, 204 for use of table.

Central Angle	Tan- gent	Ex- ternal	Central Angle	Tan- gent	Ex- ternal	Central Angle	Tan- gent	Ex- ternal	Central Angle	Tan- gent	Ex- ternal
1°	50.00	0.22	31°	1588.95	216.25	61°	3374.98	920.1	91°	5830.46	2444.9
30'	75.00	0.49	30'	1615.91	223.51	30'	3408.74	937.3	30'	5881.58	2481.5
2°	100.01	0.87	32°	1642.93	230.90	62°	3442.68	954.8	92°	5933.15	2518.5
30'	125.02	1.36	30'	1670.02	238.43	30'	3476.79	972.4	30'	5985.20	2556.0
3°	150.03	1.96	33°	1697.18	246.08	63°	3511.09	990.2	93°	6037.72	2594.0
30'	175.05	2.67	30'	1724.41	253.87	30'	3545.57	1008.3	30'	6090.72	2632.6
4°	200.08	3.49	34°	1751.71	261.80	64°	3580.24	1026.6	94°	6144.22	2671.6
30'	225.12	4.42	30'	1779.08	269.86	30'	3615.09	1045.2	30'	6198.22	2711.2
5°	250.16	5.46	35°	1806.53	278.05	65°	3650.14	1063.9	95°	6252.74	2751.3
30'	275.21	6.61	30'	1834.05	286.39	30'	3685.39	1082.9	30'	6307.77	2792.0
6°	300.27	7.86	36°	1861.65	294.86	66°	3720.83	1102.2	96°	6363.34	2833.2
30'	325.35	9.23	30'	1889.33	303.47	30'	3756.48	1121.7	30'	6419.45	2875.0
7°	350.44	10.71	37°	1917.09	312.22	67°	3792.33	1141.4	97°	6476.11	2917.3
30'	375.54	12.29	30'	1944.93	321.11	30'	3828.38	1161.3	30'	6533.33	2960.3
8°	400.65	13.99	38°	1972.85	330.15	68°	3864.65	1181.6	98°	6591.13	3003.8
30'	425.78	15.80	30'	2000.86	339.32	30'	3901.13	1202.0	30'	6649.50	3047.9
9°	450.93	17.72	39°	2028.95	348.64	69°	3937.83	1222.7	99°	6708.47	3092.7
30'	476.09	19.75	30'	2057.13	358.11	30'	3974.75	1243.7	30'	6768.05	3138.1
10°	501.27	21.89	40°	2085.40	367.72	70°	4011.89	1265.0	100°	6828.25	3184.1
30'	526.47	24.14	30'	2113.75	377.47	30'	4049.27	1286.5	30'	6889.07	3230.8
11°	551.70	26.50	41°	2142.20	387.38	71°	4086.87	1308.2	101°	6950.53	3278.1
30'	576.94	28.97	30'	2170.74	397.43	30'	4124.71	1330.3	30'	7012.65	3326.1
12°	602.20	31.56	42°	2199.38	407.64	72°	4162.78	1352.6	102°	7075.44	3374.9
30'	627.49	34.26	30'	2228.11	417.99	30'	4201.10	1375.2	30'	7138.91	3424.4
13°	652.80	37.07	43°	2256.94	428.50	73°	4239.66	1398.0	103°	7203.07	3474.3
30'	678.14	39.99	30'	2285.87	439.16	30'	4278.48	1421.2	30'	7267.94	3525.2
14°	703.50	43.03	44°	2314.90	449.98	74°	4317.55	1444.6	104°	7333.53	3576.8
30'	728.89	46.18	30'	2344.03	460.95	30'	4356.87	1468.4	30'	7399.85	3629.2
15°	754.31	49.44	45°	2373.27	472.08	75°	4396.46	1492.4	105°	7466.93	3682.3
30'	779.76	52.82	30'	2402.61	483.37	30'	4436.31	1516.7	30'	7534.78	3736.2
16°	805.24	56.31	46°	2432.06	494.82	76°	4476.44	1541.4	106°	7603.41	3791.0
30'	830.75	59.91	30'	2461.62	506.42	30'	4516.83	1566.3	30'	7672.84	3846.5
17°	856.29	63.63	47°	2491.29	518.20	77°	4557.51	1591.6	107°	7743.08	3902.9
30'	881.87	67.47	30'	2521.07	530.13	30'	4598.47	1617.1	30'	7814.16	3960.1
18°	907.48	71.42	48°	2550.97	542.23	78°	4639.72	1643.0	108°	7886.09	4018.2
30'	933.12	75.49	30'	2580.99	554.50	30'	4681.26	1669.2	30'	7958.89	4077.2
19°	958.80	79.67	49°	2611.12	566.94	79°	4723.10	1695.8	109°	8032.57	4137.1
30'	984.52	83.97	30'	2641.37	579.54	30'	4765.24	1722.7	30'	8107.17	4197.9
20°	1010.28	88.39	50°	2671.75	592.32	80°	4807.69	1749.9	110°	8182.69	4259.7
30'	1036.08	92.92	30'	2702.24	605.27	30'	4850.45	1777.4	30'	8259.15	4322.4
21°	1061.91	97.58	51°	2732.87	618.39	81°	4893.52	1805.3	111°	8336.59	4386.1
30'	1087.79	102.35	30'	2763.62	631.69	30'	4936.92	1833.6	30'	8415.01	4450.9
22°	1113.72	107.24	52°	2794.50	645.17	82°	4980.65	1862.2	112°	8494.45	4516.6
30'	1139.68	112.25	30'	2825.52	658.83	30'	5024.71	1891.2	30'	8574.92	4583.4
23°	1165.70	117.38	53°	2856.66	672.66	83°	5069.10	1920.5	113°	8656.45	4651.3
30'	1191.75	122.63	30'	2887.95	686.68	30'	5113.84	1950.3	30'	8739.06	4720.3
24°	1217.86	128.00	54°	2919.37	700.89	84°	5158.93	1980.4	114°	8822.78	4790.4
30'	1244.01	133.50	30'	2950.93	715.28	30'	5204.38	2010.8	30'	8907.63	4861.7
25°	1270.22	139.11	55°	2982.63	729.85	85°	5250.19	2041.7	115°	8993.64	4934.1
30'	1296.47	144.85	30'	3014.48	744.62	30'	5296.37	2073.0	30'	9080.83	5007.8
26°	1322.78	150.71	56°	3046.47	759.58	86°	5342.92	2104.7	116°	9169.24	5082.7
30'	1349.14	156.70	30'	3078.61	774.73	30'	5389.85	2136.7	30'	9258.89	5158.8
27°	1375.55	162.81	57°	3110.91	790.08	87°	5437.17	2169.2	117°	9349.82	5236.2
30'	1402.02	169.04	30'	3143.35	805.62	30'	5484.88	2202.2	30'	9442.05	5315.0
28°	1428.54	175.41	58°	3175.96	821.37	88°	5532.99	2235.5	118°	9535.62	5395.1
30'	1455.13	181.89	59°	3208.72	837.31	30'	5581.51	2269.3	30'	9630.55	5476.5
29°	1481.77	188.51	60°	3241.64	853.46	89°	5630.44	2303.5	119°	9726.89	5559.4
30'	1508.47	195.25	30'	3274.72	869.82	30'	5679.79	2338.2	30'	9824.67	5643.8
30°	1535.24	202.12	60°	3307.97	886.38	90°	5729.58	2373.3	120°	9923.92	5729.7
30'	1562.06	209.12	30'	3341.39	903.15	30'	5779.80	2408.9	30'	10,024.68	5817.0

**TABLE 5. CORRECTIONS FOR TANGENTS AND EXTERNALS**

For railroad and highway curves laid out by the chord definition these corrections are to be added to the values found, using table on p. 208, in order to obtain the corrected tangents and external distances.

For Tangents Add \*

Central Angle	Degree of Curve													
	5°	10°	15°	20°	25°	30°	35°	40°	45°	50°	55°	60°	65°	70°
10°	.03	.06	.09	.13	.16	.19	.22	.25	.28	.31	.34	.38	.42	.46
15°	.04	.10	.14	.19	.24	.29	.34	.39	.45	.51	.53	.58	.63	.68
20°	.06	.13	.19	.26	.32	.39	.45	.51	.58	.65	.72	.79	.84	.90
25°	.08	.16	.24	.36	.40	.49	.58	.67	.75	.83	.90	.99	1.06	1.14
30°	.10	.19	.29	.39	.49	.59	.69	.79	.89	.99	1.09	1.20	1.29	1.39
35°	.11	.22	.34	.47	.58	.69	.79	.81	.92	1.04	1.29	1.42	1.54	1.66
40°	.13	.26	.40	.53	.67	.80	.93	1.06	1.20	1.34	1.49	1.64	1.79	1.94
45°	.15	.30	.44	.60	.76	.91	1.06	1.21	1.37	1.52	1.70	1.87	2.04	2.21
50°	.17	.34	.51	.68	.85	1.02	1.19	1.36	1.54	1.72	1.91	2.10	2.29	2.48
55°	.19	.38	.57	.76	.95	1.14	1.32	1.52	1.72	1.92	2.14	2.35	2.56	2.77
60°	.21	.42	.63	.84	1.05	1.27	1.49	1.71	1.94	2.17	2.38	2.60	2.83	3.07
65°	.23	.46	.69	.93	1.16	1.40	1.64	1.88	2.13	2.38	2.63	2.88	3.13	3.39
70°	.25	.51	.76	1.02	1.28	1.54	1.80	2.06	2.33	2.60	2.88	3.16	3.44	3.72
75°	.27	.56	.83	1.12	1.40	1.69	1.98	2.27	2.57	2.87	3.16	3.47	3.78	4.09
80°	.30	.61	.91	1.22	1.53	1.84	2.15	2.46	2.78	3.10	3.44	3.78	4.12	4.46
85°	.33	.66	1.00	1.33	1.68	2.02	2.36	2.70	3.05	3.40	3.77	4.14	4.55	4.89
90°	.36	.72	1.09	1.45	1.83	2.20	2.57	2.94	3.32	3.70	4.10	4.50	4.91	5.32
95°	.39	.79	1.19	1.55	2.00	2.40	2.80	3.20	3.61	4.02	4.40	4.98	5.38	5.83
100°	.43	.86	1.30	1.74	2.18	2.62	3.06	3.50	3.95	4.40	4.88	5.37	5.85	6.34
110°	.51	1.03	1.56	2.08	2.61	3.14	3.67	4.21	4.76	5.31	5.86	6.43	7.01	7.60
120°	.62	1.25	1.93	2.52	3.16	3.81	4.45	5.11	5.77	6.44	7.12	7.80	8.50	9.22

For External Add \*

Central Angle	Degree of Curve													
	5°	10°	15°	20°	25°	30°	35°	40°	45°	50°	55°	60°	65°	70°
10°	.001	.003	.004	.006	.007	.008	.009	.011	.012	.014	.015	.017	.018	.020
15°	.003	.007	.010	.014	.018	.023	.027	.029	.032	.035	.039	.043	.047	.051
20°	.006	.011	.017	.022	.028	.034	.038	.045	.051	.057	.063	.070	.076	.083
25°	.009	.018	.027	.036	.046	.056	.065	.074	.083	.093	.106	.120	.127	.135
30°	.013	.025	.038	.051	.065	.078	.090	.103	.116	.129	.149	.170	.179	.188
35°	.018	.035	.054	.072	.086	.109	.131	.153	.175	.197	.213	.230	.247	.264
40°	.023	.046	.070	.093	.117	.141	.172	.203	.234	.265	.277	.290	.315	.341
45°	.030	.060	.093	.119	.153	.184	.216	.254	.289	.325	.351	.378	.411	.445
50°	.037	.075	.116	.151	.189	.227	.266	.305	.345	.384	.425	.467	.508	.550
55°	.046	.093	.142	.188	.236	.283	.332	.381	.420	.479	.530	.582	.641	.700
60°	.056	.112	.168	.225	.283	.340	.398	.457	.516	.575	.636	.697	.774	.851
65°	.067	.135	.204	.273	.343	.412	.483	.554	.625	.697	.711	.845	.922	1.01
70°	.080	.159	.240	.321	.403	.485	.568	.652	.735	.819	.906	.994	1.08	1.17
75°	.095	.182	.266	.353	.440	.528	.618	.707	.797	.877	1.07	1.18	1.29	1.39
80°	.110	.220	.332	.445	.558	.671	.787	.903	1.02	1.13	1.25	1.38	1.50	1.62
85°	.128	.259	.391	.525	.657	.790	.926	1.06	1.20	1.34	1.47	1.62	1.76	1.91
90°	.149	.299	.450	.603	.756	.910	1.07	1.22	1.38	1.54	1.70	1.87	2.03	2.20
95°	.174	.350	.522	.706	.895	1.06	1.25	1.43	1.62	1.80	1.99	2.18	2.38	2.58
100°	.200	.401	.604	.809	1.01	1.22	1.43	1.64	1.85	2.06	2.28	2.50	2.73	2.96
110°	.268	.536	.806	1.08	1.35	1.63	1.91	2.20	2.48	2.76	3.05	3.35	3.66	3.96
120°	.360	.721	1.08	1.45	1.82	2.19	2.57	2.95	3.33	3.72	4.11	4.50	4.91	5.32

\* Adapted from Dietzgen's Railroad Curve Tables by Eugene Dietzgen Co.

TABLE 6. DEFLECTIONS AND CHORD LENGTHS FOR CIRCULAR CURVES

For Laying Out Arc Definition Curves By Measured Chords

Degree of Curve	Radius	Deflection for Arc Length				Chord for Arc Length		
		Deflection = arc length (0.3° of curve)				Chord = 2R sin def.		
		1'	25'	50'	100'	25'	50'	100'
0° 30'	11,459.16	0° 00.15'	0° 03.75'	0° 07.50'	0° 15.00'	25.00'	50.00'	100.00'
1°	5,729.58	0° 00.30'	0° 07.50'	0° 15.00'	0° 30.00'	25.00'	50.00'	100.00'
1° 30'	3,819.72	0° 00.45'	0° 11.25'	0° 22.50'	0° 45.00'	25.00'	50.00'	100.00'
2°	2,864.79	0° 00.60'	0° 15.00'	0° 30.00'	1° 00.00'	25.00'	50.00'	100.00'
2° 30'	2,291.83	0° 00.75'	0° 18.75'	0° 37.50'	1° 15.00'	25.00'	50.00'	99.99'
3°	1,909.86	0° 00.90'	0° 22.50'	0° 45.00'	1° 30.00'	25.00'	50.00'	99.99'
3° 30'	1,637.02	0° 01.05'	0° 26.25'	0° 52.50'	1° 45.00'	25.00'	50.00'	99.98'
4°	1,432.40	0° 01.20'	0° 30.00'	1° 00.00'	2° 00.00'	25.00'	50.00'	99.98'
4° 30'	1,273.24	0° 01.35'	0° 33.75'	1° 07.50'	2° 15.00'	25.00'	50.00'	99.97'
5°	1,145.92	0° 01.50'	0° 37.50'	1° 15.00'	2° 30.00'	25.00'	50.00'	99.97'
5° 30'	1,041.74	0° 01.65'	0° 41.25'	1° 22.50'	2° 45.00'	25.00'	50.00'	99.96'
6°	954.93	0° 01.80'	0° 45.00'	1° 30.00'	3° 00.00'	25.00'	50.00'	99.95'
6° 30'	881.47	0° 01.95'	0° 48.75'	1° 37.50'	3° 15.00'	25.00'	50.00'	99.95'
7°	818.51	0° 02.10'	0° 52.50'	1° 45.00'	3° 30.00'	25.00'	50.00'	99.94'
7° 30'	763.94	0° 02.25'	0° 56.25'	1° 52.50'	3° 45.00'	25.00'	49.99'	99.93'
8°	716.20	0° 02.40'	1° 00.00'	2° 00.00'	4° 00.00'	25.00'	49.99'	99.92'
8° 30'	674.07	0° 02.55'	1° 03.75'	2° 07.50'	4° 15.00'	25.00'	49.99'	99.91'
9°	636.62	0° 02.70'	1° 07.50'	2° 15.00'	4° 30.00'	25.00'	49.99'	99.90'
9° 30'	603.11	0° 02.85'	1° 11.25'	2° 22.50'	4° 45.00'	25.00'	49.99'	99.89'
10°	572.96	0° 03.00'	1° 15.00'	2° 30.00'	5° 00.00'	25.00'	49.98'	99.87'
11°	520.87	0° 03.30'	1° 22.50'	2° 45.00'	5° 30.00'	25.00'	49.98'	99.85'
12°	477.46	0° 03.60'	1° 30.00'	3° 00.00'	6° 00.00'	25.00'	49.98'	99.82'
13°	440.74	0° 03.90'	1° 37.50'	3° 15.00'	6° 30.00'	25.00'	49.97'	99.79'
14°	409.26	0° 04.20'	1° 45.00'	3° 30.00'	7° 00.00'	25.00'	49.97'	99.75'
15°	381.97	0° 04.50'	1° 52.50'	3° 45.00'	7° 30.00'	25.00'	49.96'	99.72'
16°	358.10	0° 04.80'	2° 00.00'	4° 00.00'	8° 00.00'	25.00'	49.96'	99.68'
17°	337.03	0° 05.10'	2° 07.50'	4° 15.00'	8° 30.00'	25.00'	49.95'	99.63'
18°	318.31	0° 05.40'	2° 15.00'	4° 30.00'	9° 00.00'	24.99'	49.95'	99.59'
19°	301.56	0° 05.70'	2° 22.50'	4° 45.00'	9° 30.00'	24.99'	49.94'	99.54'
20°	286.48	0° 06.00'	2° 30.00'	5° 00.00'	10° 00.00'	24.99'	49.94'	99.49'
21°	272.84	0° 06.30'	2° 37.50'	5° 15.00'	10° 30.00'	24.99'	49.93'	99.44'
22°	260.44	0° 06.60'	2° 45.00'	5° 30.00'	11° 00.00'	24.99'	49.92'	99.39'
23°	249.11	0° 06.90'	2° 52.50'	5° 45.00'	11° 30.00'	24.99'	49.92'	99.33'
24°	238.73	0° 07.20'	3° 00.00'	6° 00.00'	12° 00.00'	24.99'	49.91'	99.27'
38° 12'	150	0° 11.45'	4° 46.48'	9° 32.96'	19° 05.92'	24.97'	49.77'	98.16'
28° 39'	200	0° 08.59'	3° 34.86'	7° 09.72'	14° 19.44'	24.98'	49.87'	98.96'
25° 28'	225	0° 07.64'	3° 10.99'	6° 21.97'	12° 43.94'	24.99'	49.90'	99.18'
22° 55'	250	0° 06.88'	2° 51.89'	5° 43.78'	11° 27.55'	24.99'	49.92'	99.34'
20° 50'	275	0° 06.25'	2° 36.26'	5° 12.52'	10° 25.04'	24.99'	49.93'	99.45'
19° 06'	300	0° 05.73'	2° 23.24'	4° 46.48'	9° 32.96'	24.99'	49.94'	99.54'
17° 38'	325	0° 05.29'	2° 12.22'	4° 24.44'	8° 48.88'	24.99'	49.95'	99.61'
16° 22'	350	0° 04.91'	2° 02.78'	4° 05.55'	8° 11.11'	25.00'	49.96'	99.66'
15° 17'	375	0° 04.58'	1° 54.59'	3° 49.18'	7° 38.37'	25.00'	49.96'	99.70'
14° 19'	400	0° 04.30'	1° 47.43'	3° 34.86'	7° 09.72'	25.00'	49.97'	99.74'
12° 44'	450	0° 03.82'	1° 35.49'	3° 10.99'	6° 21.97'	25.00'	49.97'	99.79'
11° 28'	500	0° 03.44'	1° 25.04'	2° 51.89'	5° 43.77'	25.00'	49.98'	99.83'
10° 25'	550	0° 03.13'	1° 18.13'	2° 36.26'	5° 12.52'	25.00'	49.98'	99.86'
9° 33'	600	0° 02.86'	1° 11.62'	2° 23.24'	4° 46.48'	25.00'	49.99'	99.89'
8° 50'	650	0° 02.64'	1° 06.11'	2° 12.22'	4° 24.44'	25.00'	49.99'	99.90'
8° 11'	700	0° 02.46'	1° 01.39'	2° 02.78'	4° 05.55'	25.00'	49.99'	99.92'
7° 88'	750	0° 02.29'	0° 57.30'	1° 54.59'	3° 49.18'	25.00'	50.00'	99.93'
7° 10'	800	0° 02.15'	0° 53.71'	1° 47.43'	3° 34.86'	25.00'	50.00'	99.93'
6° 44'	850	0° 02.02'	0° 50.56'	1° 41.11'	3° 22.22'	25.00'	50.00'	99.94'
6° 22'	900	0° 01.91'	0° 47.75'	1° 35.49'	3° 10.99'	25.00'	50.00'	99.95'
6° 02'	950	0° 01.81'	0° 45.23'	1° 30.47'	3° 00.98'	25.00'	50.00'	99.95'
5° 44'	1000	0° 01.72'	0° 42.97'	1° 25.94'	2° 51.89'	25.00'	50.00'	99.96'

Deflection for curves of even radii =  $\frac{1718.873}{R}$  arc length.

**TABLE 7. LENGTHS OF CIRCULAR ARCS FOR UNIT RADIUS \***

By the use of this table, the length of any arc may be found if the length of the radius and the angle of the segment are known. *EXAMPLE.* Required: The length of arc of segment of 32° 15' 27" with radius of 24 ft. 3 in.

From table: Length of arc (radius 1) for 32° = 0.5585054  
 15' = 0.0043633  
 27" = 0.0001309

0.5629996

0.5629996 × 24.25 (length of radius) = 13.65 ft.

Degrees				Minutes				Seconds			
°	'	"	Length	°	'	"	Length	°	'	"	Length
0				1				1			
1	.017 4533	61	1.064 6508	121	2.111 8484	1	.000 2909	1	.000 0048		
2	.034 9006	62	1.082 1041	122	2.129 3017	2	.000 5818	2	.000 0097		
3	.052 3599	63	1.099 5574	123	2.146 7550	3	.000 8727	3	.000 0145		
4	.069 8132	64	1.117 0107	124	2.164 2083	4	.001 1636	4	.000 0194		
5	.087 2665	65	1.134 4640	125	2.181 6616	5	.001 4544	5	.000 0242		
6	.104 7198	66	1.151 9173	126	2.199 1149	6	.001 7453	6	.000 0291		
7	.122 1730	67	1.169 3706	127	2.216 5682	7	.002 0362	7	.000 0339		
8	.139 6263	68	1.186 8239	128	2.234 0214	8	.002 3271	8	.000 0388		
9	.157 0796	69	1.204 2772	129	2.251 4747	9	.002 6180	9	.000 0436		
10	.174 5329	70	1.221 7305	130	2.268 9280	10	.002 9089	10	.000 0485		
11	.191 9862	71	1.239 1838	131	2.286 3813	11	.003 1998	11	.000 0533		
12	.209 4395	72	1.256 6371	132	2.303 8346	12	.003 4907	12	.000 0582		
13	.226 8928	73	1.274 0904	133	2.321 2879	13	.003 7815	13	.000 0630		
14	.244 3461	74	1.291 5436	134	2.338 7412	14	.004 0724	14	.000 0679		
15	.261 7994	75	1.308 9969	135	2.356 1945	15	.004 3633	15	.000 0727		
16	.279 2527	76	1.326 4502	136	2.373 6478	16	.004 6542	16	.000 0776		
17	.296 7060	77	1.343 9035	137	2.391 1011	17	.004 9451	17	.000 0824		
18	.314 1593	78	1.361 3568	138	2.408 5544	18	.005 2360	18	.000 0873		
19	.331 6126	79	1.378 8101	139	2.426 0077	19	.005 5269	19	.000 0921		
20	.349 0659	80	1.396 2634	140	2.443 4610	20	.005 8178	20	.000 0970		
21	.366 5191	81	1.413 7167	141	2.460 9142	21	.006 1087	21	.000 1018		
22	.383 9724	82	1.431 1700	142	2.478 3675	22	.006 3995	22	.000 1067		
23	.401 4257	83	1.448 6233	143	2.495 8208	23	.006 6904	23	.000 1115		
24	.418 8790	84	1.466 0766	144	2.513 2741	24	.006 9812	24	.000 1164		
25	.436 3323	85	1.483 5299	145	2.530 7274	25	.007 2722	25	.000 1212		
26	.453 7856	86	1.500 9832	146	2.548 1807	26	.007 5631	26	.000 1261		
27	.471 2389	87	1.518 4364	147	2.565 6340	27	.007 8540	27	.000 1309		
28	.488 6922	88	1.535 8897	148	2.583 0873	28	.008 1449	28	.000 1357		
29	.506 1455	89	1.553 3430	149	2.600 5406	29	.008 4358	29	.000 1405		
30	.523 5988	90	1.570 7963	150	2.617 9939	30	.008 7266	30	.000 1454		
31	.541 0521	91	1.588 2496	151	2.635 4472	31	.009 0175	31	.000 1503		
32	.558 5054	92	1.605 7029	152	2.652 9005	32	.009 3084	32	.000 1551		
33	.575 9587	93	1.623 1562	153	2.670 3538	33	.009 5993	33	.000 1600		
34	.593 4119	94	1.640 6095	154	2.687 8071	34	.009 8902	34	.000 1648		
35	.610 8652	95	1.658 0628	155	2.705 2604	35	.010 1811	35	.000 1697		
36	.628 3185	96	1.675 5161	156	2.722 7136	36	.010 4720	36	.000 1745		
37	.645 7718	97	1.692 9694	157	2.740 1669	37	.010 7629	37	.000 1794		
38	.663 2251	98	1.710 4227	158	2.757 6202	38	.011 0538	38	.000 1842		
39	.680 6784	99	1.727 8760	159	2.775 0735	39	.011 3446	39	.000 1891		
40	.698 1317	100	1.745 3293	160	2.792 5268	40	.011 6355	40	.000 1939		
41	.715 5850	101	1.762 7825	161	2.809 9801	41	.011 9264	41	.000 1988		
42	.733 0383	102	1.780 2358	162	2.827 4334	42	.012 2173	42	.000 2036		
43	.750 4916	103	1.797 6891	163	2.844 8867	43	.012 5082	43	.000 2085		
44	.767 9449	104	1.815 1424	164	2.862 3400	44	.012 7991	44	.000 2133		
45	.785 3982	105	1.832 5957	165	2.879 7933	45	.013 0900	45	.000 2182		
46	.802 8515	106	1.850 0490	166	2.897 2466	46	.013 3809	46	.000 2230		
47	.820 3047	107	1.867 5023	167	2.914 6999	47	.013 6717	47	.000 2279		
48	.837 7580	108	1.884 9556	168	2.932 1531	48	.013 9626	48	.000 2327		
49	.855 2113	109	1.902 4089	169	2.949 6064	49	.014 2535	49	.000 2376		
50	.872 6646	110	1.919 8622	170	2.967 0597	50	.014 5444	50	.000 2424		
51	.890 1179	111	1.937 3155	171	2.984 5130	51	.014 8353	51	.000 2473		
52	.907 5712	112	1.954 7688	172	3.001 9663	52	.015 1262	52	.000 2521		
53	.925 0245	113	1.972 2221	173	3.019 4196	53	.015 4171	53	.000 2570		
54	.942 4778	114	1.989 6753	174	3.036 8729	54	.015 7080	54	.000 2618		
55	.959 9311	115	2.007 1286	175	3.054 3262	55	.015 9989	55	.000 2666		
56	.977 3844	116	2.024 5819	176	3.071 7795	56	.016 2897	56	.000 2715		
57	.994 8377	117	2.042 0352	177	3.089 2328	57	.016 5806	57	.000 2763		
58	1.012 2910	118	2.059 4885	178	3.106 6861	58	.016 8715	58	.000 2812		
59	1.029 7443	119	2.076 9418	179	3.124 1394	59	.017 1624	59	.000 2860		
60	1.047 1976	120	2.094 3951	180	3.141 5927	60	.017 4533	60	.000 2909		

\* From War Department, Surveying Tables.

TABLE 8. METRIC CURVES

Deflection Angle 20-m. Chord	Radius in Meters	Log of Radius	Mid. Ordinate	Tangent Offset	Degree of Equivalent U. S. Curve	Deflection Angle 20-m. Chord
0° 10'	3437.75	3.536274	.015	0.058	0° 30'	0° 10'
20	1718.89	3.235246	.029	0.116	1 01	20
30	1145.93	3.059158	.044	0.175	1 31	30
40	859.46	2.934224	.058	0.233	2 02	40
50	687.57	2.837319	.073	0.291	2 32	50
1 00	572.99	2.758145	.087	0.349	3 03	1 00
10	491.14	2.691206	.102	0.407	3 33	10
20	429.76	2.633223	.116	0.465	4 04	20
30	382.02	2.582081	.131	0.524	4 34	30
40	343.82	2.536335	.145	0.582	5 05	40
50	312.58	2.494955	.160	0.640	5 35	50
2 00	286.54	2.457181	.175	0.698	6 06	2 00
10	264.51	2.422434	.189	0.756	6 36	10
20	245.62	2.390266	.204	0.814	7 07	20
30	229.26	2.360320	.218	0.872	7 37	30
40	214.94	2.332311	.233	0.931	8 08	40
50	202.30	2.306002	.247	0.989	8 38	50
3 00	191.07	2.281200	.262	1.047	9 09	3 00
10	181.03	2.257741	.276	1.105	9 40	10
20	171.98	2.235489	.291	1.163	10 10	20
30	163.80	2.214325	.306	1.221	10 41	30
40	156.37	2.194148	.320	1.279	11 11	40
50	149.58	2.174870	.335	1.337	11 42	50
4 00	143.36	2.156416	.349	1.395	12 12	4 00
10	137.63	2.138717	.364	1.453	12 43	10
20	132.35	2.121715	.378	1.511	13 13	20
30	127.45	2.105357	.393	1.569	13 44	30
40	122.91	2.089596	.407	1.627	14 15	40
50	118.68	2.074391	.422	1.685	14 45	50
5 00	114.737	2.059704	.437	1.743	15 16	5 00
10	111.045	2.045501	.451	1.801	15 47	10
20	107.585	2.031751	.466	1.859	16 17	20
30	104.334	2.018427	.480	1.917	16 48	30
40	101.275	2.005503	.495	1.975	17 19	40
50	98.391	1.992956	.509	2.033	17 49	50
6 00	95.668	1.980765	.524	2.091	18 20	6 00
10	93.092	1.968911	.539	2.148	18 51	10
20	90.652	1.957375	.553	2.206	19 21	20
30	88.337	1.946141	.568	2.264	19 52	30
40	86.138	1.935194	.582	2.322	20 23	40
50	84.047	1.924520	.597	2.380	20 54	50
7 00	82.055	1.914105	.612	2.437	21 24	7 00
10	80.156	1.903938	.626	2.495	21 55	10
20	78.344	1.894008	.641	2.553	22 26	20
30	76.613	1.884302	.655	2.611	22 57	30
40	74.957	1.874813	.670	2.668	23 28	40
50	73.372	1.865530	.685	2.726	23 59	50
8 00	71.853	1.856445	.699	2.783	24 29	8 00
10	70.396	1.847549	.714	2.841	25 00	10
20	68.998	1.838836	.729	2.899	25 31	20
30	67.655	1.830298	.743	2.956	26 02	30
40	66.363	1.821928	.758	3.014	26 33	40
50	65.121	1.813720	.772	3.071	27 04	50
9 00	63.925	1.805668	.787	3.129	27 35	9 00
10	62.772	1.797766	.802	3.186	28 06	10
20	61.661	1.790008	.816	3.244	28 37	20
30	60.589	1.782391	.831	3.301	29 08	30
40	59.554	1.774908	.846	3.358	29 39	40
50	58.554	1.767556	.860	3.416	30 10	50
10° 00'	57.588	1.760330	.875	3.473	30 41	10° 00'

## SHORT-RADIUS CURVES

*Note.* The degree of curve is not usually used for the curves involved in street intersections, curbs, road intersections, runway and taxiway fillets, and turnarounds, traffic circles, rotaries, cloverleaves, etc. These curves are defined by the radius  $R$ , and central angle,  $\Delta$  or  $\theta$ .

### NOTATION

$T$  = tangent length P.C. or P.T. to P.I.

$L$  = arc length P.C. to P.T.

$l$  = arc length for any subchord

$C$  = long chord P.C. to P.T.

$c$  = any subchord.

$d$  = deflection to any point.

$\Delta$  = central angle in degrees.

$\theta$  = central angle in radians.

$$\begin{aligned} \text{One radian} &= \frac{360^\circ}{2\pi} = \frac{180^\circ}{\pi} \\ &= 57.2958^\circ \\ &= 57^\circ 17' 44.8'' \end{aligned}$$

$\pi = 3.14159$ .

$M$  = mid. ordinate;  $m$  for subchords.

$E$  = external;  $e$  for subchords.

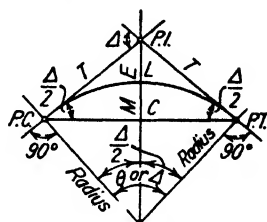

Short-radius Curve

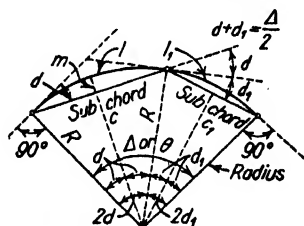

Subchords and Deflections

$$R = \frac{L}{\theta} = \frac{L \cdot 180/\Delta}{\pi} = \frac{L}{\Delta} 57.2958 = T \cdot \cot \frac{\Delta}{2} = \frac{C}{2 \sin \Delta/2}$$

$$\frac{4M^2 + C^2}{8M} = \frac{M^2 + (C/2)^2}{2M}$$

$$L = R\theta = \frac{\Delta R \pi}{180} = 0.017453 \Delta R = \text{circum.} \cdot \frac{\Delta}{360}$$

$$T = R \cdot \tan \frac{\Delta}{2} = E \cdot \cot \frac{\Delta}{4} = \frac{C}{2 \cos \Delta/2}$$

$$C = 2R \cdot \sin \frac{\Delta}{2} = 2T \cdot \cos \frac{\Delta}{2} = 2\sqrt{M(2R - M)}$$

$$M = R \cdot \text{vers} \frac{\Delta}{2} = E \cdot \cos \frac{\Delta}{2} = R \left( 1 - \cos \frac{\Delta}{2} \right)$$

$$E = R \cdot \text{exsec} \frac{\Delta}{2} = T \cdot \tan \frac{\Delta}{4} = \frac{R}{\cos \Delta/2} - R$$

$$\Delta = \frac{180L}{\pi R} = 57.2958 \frac{L}{R} = \theta \cdot 57.2958$$



$$\theta = \frac{L}{R} = \frac{\Delta\pi}{180} = \Delta \cdot 0.017453.$$

$$\sin \frac{\Delta}{2} = \frac{C}{2R}; \quad \cos \frac{\Delta}{2} = \frac{R - M}{R} = \frac{C}{2T}; \quad \tan \frac{\Delta}{2} = \frac{T}{R}$$

$$\text{Subcord} = 2R \cdot \sin d = 2(R - M) \cdot \tan d.$$

$$d(\text{in minutes}) = 1718.873 \frac{l}{R}. \quad \text{Radius} = \frac{C}{2 \sin d}.$$

$$\text{Length} = \frac{\pi R d}{90} = 0.034906 R d (d \text{ in degrees}).$$

$$\text{Mid. ordinate} = R(1 - \cos d) = 2R \cdot \sin^2 \frac{d}{2}$$

$$\tan d = \frac{\frac{1}{2}C}{R - m}; \quad \sin d = \frac{\frac{1}{2}C}{R}$$

$$\text{Excess of } l \text{ over } c = l - c = l - 2R \cdot \sin d.$$

$$\text{Sum of deflection angles, } d_1 + d_2 + \dots + d_n = \frac{\Delta}{2}$$

Concentric Curves

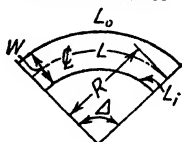

$$L_0 = \frac{R + W/2}{R} L$$

$$L_i = \frac{R - W/2}{R} L$$

$$L_0 - L_i = 0.017453 W \cdot \Delta$$

$$= W \cdot L/R$$

$$\text{Area} = L \cdot W$$

**EXAMPLE.** Given.  $R = 50'$ ;  $\Delta = 110^\circ$  ( $\theta = 1.9195$ );  $l = 50'$ .

**Required.**  $L$ ,  $l_1$ ,  $d$ ,  $d_1$ ,  $c$ , and  $c_1$ .

**Solution.**

$$L = 50 \times 1.9195 = 95.98'; \quad l_1 = 95.98 - 50 = 45.98'.$$

$$d = 1718.873 \times 50/50 = 28^\circ 39'.$$

$$d_1 = 1718.873 \times \frac{45.98}{50} = 26^\circ 21'.$$

$$c = 2R \sin 28^\circ 39' = 47.946'.$$

$$c_1 = 2R \sin 26^\circ 21' = 44.385'.$$

TABLE 9. DEFLECTIONS (d) AND MIDDLE ORDINATES (m) FOR SUBCHORDS \*

X	Radius		10'	12'	15'	18'	20'	25'	30'	35'	40'	45'	50'	60'	70'	80'	90'	100'	120'	150'
	Deflection	Chord	14° 29'	12° 01'	9° 36'	7° 59'	7° 11'	5° 44'	4° 47'	4° 06'	3° 35'	3° 11'	2° 52'	2° 23'	2° 03'	1° 47'	1° 35'	1° 26'	1° 12'	0° 57'
M.	5'	10'	30° 00'	24° 37'	19° 28'	16° 08'	14° 29'	11° 32'	9° 36'	8° 13'	7° 11'	6° 23'	5° 44'	4° 47'	4° 06'	3° 35'	3° 11'	2° 52'	2° 23'	1° 55'
	10'	20'	56° 26'	56° 27'	41° 49'	33° 45'	30° 00'	23° 35'	19° 28'	16° 36'	14° 29'	12° 50'	11° 32'	9° 36'	8° 13'	7° 11'	6° 23'	5° 44'	4° 47'	3° 49'
	20'	35'	43° 59'	43° 59'	20° 55'	18° 13'	16° 08'	14° 29'	12° 50'	11° 32'	10° 17'	9° 36'	8° 13'	7° 11'	6° 23'	5° 44'	4° 47'	3° 49'	2° 52'	1° 55'
	35'	50'	38° 41'	38° 41'	24° 37'	20° 55'	18° 13'	16° 08'	14° 29'	12° 50'	11° 32'	10° 17'	9° 36'	8° 13'	7° 11'	6° 23'	5° 44'	4° 47'	3° 49'	2° 52'
	50'	100'	33° 45'	33° 45'	24° 37'	20° 55'	18° 13'	16° 08'	14° 29'	12° 50'	11° 32'	10° 17'	9° 36'	8° 13'	7° 11'	6° 23'	5° 44'	4° 47'	3° 49'	2° 52'
M.	10'	20'	1.34	1.09	0.86	0.71	0.64	0.51	0.42	0.36	0.31	0.28	0.25	0.21	0.18	0.16	0.14	0.13	0.10	0.08
			5.37	3.82	3.03	2.68	2.09	1.72	1.46	1.27	1.12	1.01	0.84	0.72	0.63	0.56	0.50	0.42	0.33	0.25

\* Adapted from *Lefax Society, Inc., Philadelphia, Pa.*

Circle



$$\text{Area} = \pi R^2 = \frac{\pi D^2}{4}$$

$$\text{Circumference} = 2\pi R = \pi D.$$

$$R = \frac{\text{Cir.}}{2\pi} = \frac{D}{2} = \sqrt{\frac{\text{Area}}{\pi}}$$

$$D = 2R = \text{cir.}/\pi$$

Sector of Circle

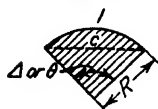

$$\begin{aligned} \text{Area} &= 0.008727R^2\Delta \\ &= \frac{l}{2} \cdot R = \pi R^2 \frac{\Delta}{360} \end{aligned}$$

$$= R^2 \cdot \frac{\theta}{2}$$

when

$$\Delta = 90^\circ: A = 0.3927C^2; 0.7854R^2$$

Segment of Circle

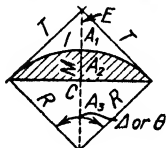

$$A_1 = R^2 \left( \tan \frac{\Delta}{2} - \frac{\Delta\pi}{360} \right) = R \left( T - \frac{l}{2} \right).$$

$$A_2 = \frac{lR - c(R - M)}{2} = \left( \pi R^2 \frac{\Delta}{360} \right) - \left[ \left( R \sin \frac{\Delta}{2} \right) \left( R \cos \frac{\Delta}{2} \right) \right].$$

$$A_2 = \left( \pi R^2 \frac{\Delta}{360} \right) - \frac{1}{2}c(R - M)$$

$$A_2 = \frac{2}{3}Mc \begin{cases} \text{Correct for parabolic segment, approximate} \\ \text{for circular segment.} \end{cases}$$

$$A_2 = \frac{1}{2}R^2(\theta - \sin \Delta) = \frac{2}{3}Mc + \frac{M^3}{2c}$$

$$A_3 = \frac{1}{2}R^2 \sin \Delta = \frac{1}{2}c(R - M) = \left( R \sin \frac{\Delta}{2} \right) \left( R \cos \frac{\Delta}{2} \right).$$

$$\text{When } \Delta = 90^\circ: A_1 = 0.2146R^2$$

$$= 1.2594E^2$$

FIG. 9. Formulas for areas.

## TRANSITION CURVES \*

### FORMULAS

$$T_s = (R_c + p) \tan \frac{\Delta}{2} + k.$$

$$E_s = (R_c + p) \operatorname{exsec} \frac{\Delta}{2} + p = \frac{R_c + p}{\cos \frac{\Delta}{2}} - R_c.$$

$$P = y_c - R_c(1 - \cos \theta_s) = \frac{y_c}{4} \text{ (approx.)}.$$

$$k = x_c - R_c \sin \theta_s = \frac{L_s}{2} \text{ (approx.)}.$$

$$\theta_s = \frac{L_s D_c}{200}; \theta = \left(\frac{L}{L_s}\right)^2 \theta_s.$$

$$\theta = \frac{L^2 D_c}{200 L_s}.$$

$$L_c = \frac{100 \Delta_c}{D_c}; \text{L.C.} = \frac{X_c}{\cos \phi_c}.$$

$$\Delta_c = \Delta - \frac{L_s D_c}{100}.$$

$$D = \frac{L}{L_s} D_c.$$

$$D_c = \frac{200 \theta_s}{L_s}.$$

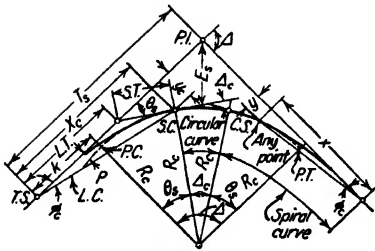

Note. At the P.C. the spiral approximately bisects  $P$ .

#### OFFSETS TO $x$ AND $y$

$$y = \frac{L^3}{L_s} y_c = L(y \text{ for } L_s = 1).$$

$$y_c = L_s(y \text{ for } L_s = 1).$$

$$x = L(x \text{ for } L_s = 1);$$

$$x_c = L_s(x \text{ for } L_s = 1).$$

#### OFFSETS TO $\frac{1}{4}$ POINTS

$$y \text{ at } \frac{1}{4} \text{ point} = y_c/4^3$$

$$y \text{ at } \frac{1}{2} \text{ point} = y_c/2^3 = P/2 \text{ (approx.)}$$

$$y \text{ at } \frac{3}{4} \text{ point} = y_c/(\frac{1}{8})^3$$

#### TOTAL LENGTH OF CURVE

$$T_s \text{ to S.T.} = 2L_s + 100 \frac{\Delta_c}{D_c}$$

$$\phi_c = \theta/3 - c; \phi = (L/L_s)^2 \phi_c.$$

FIG. 10. Circular curves with spiral transitions.

\* Adapted from *Transition Curves for Highways* by Joseph Barnett, P.R.A.

*Notes for Fig. 10.* With  $L_s$  given or selected from Table 11 below,  $p$ ,  $k$ ,  $x$ ,  $y$ , L.T., S.T., and L.C. may be computed for any spiral by multiplying functions for  $L_s = 1$  in Table 12, p. 224, by  $L_s$  or  $L$  in feet. Interpolate for values of  $\theta$  or  $\theta_s$  between even degrees. For circular curve layout see pp. 202, 203, 204.

Circular curve may be omitted and curve made transitional throughout in which case S.C. and C.S. coincide at S.C.S.,  $\theta = \Delta/2$ ,  $\Delta_c = 0$ , and  $T_s$  and  $E_s$  are computed from Table 13, p. 225.

#### NOTATION

- $R_c$  = radius of the circular curve.  
 $P$  = offset distance from tangent to the P.C. of the circular curve produced.  
 $k$  = distance from T.S. to P.C. along tangent.  
 $T_s$  = tangent distance.  
 $E_s$  = external distance.  
 $x_c, y_c$  = coordinates from T.S. to S.C. and S.T. to C.S.  
 $\theta$  = spiral angle at any point on spiral.  
 $\theta_s$  = spiral angle at S.C. or C.S.  
 $L$  = length of spiral, T.S. to any point on spiral.  
 $L_s$  = length of spiral, T.S. to S.C. or S.T. to C.S.  
 $D_c$  = degree of circular curve (arc definition).  
 $D$  = degree of curve at any point on spiral.  
 $x, y$  = coordinates from T.S. or S.T. to any point on spiral.  
 $\phi_c$  = deflection from tangent at T.S. to S.C.  
 $\phi$  = deflection from tangent at T.S., S.T. or any point on spiral to any other point on spiral.  
L.T., S.T. = long tangent, short tangent.  
L.C. = long chord of spiral transition.  
 $\Delta$  = intersection and central angle of entire curve.  
 $\Delta_c$  = intersection and central angle of circular curve.  
 $L_c$  = length of circular curve, S.C. to C.S.

*Note.* The degree of curvature varies directly as the length, from zero curvature at T.S. to the maximum of  $D_c$  at the S.C. The spiral departs from the circular curve at the same rate as from the tangent.

SPIRAL LAYOUT (See pp. 221, 222, 223 also.)

Method I: Deflections to even stations by formula  $\phi = \theta/3 = 1/3\theta_s(L/L_s)^2$ . Correct  $\phi$  for  $c$  when  $\theta > 20^\circ$ .

TABLE 10. C IN FORMULA,  $\phi = \theta/3 - C$

(For curves with  $\theta$  over  $20^\circ$ )

$\theta$ in degrees	20	25	30	35	40	45	50
c in minutes	0.4	0.8	1.4	2.2	3.4	4.8	5.6

Method II: Offsets from tangent. Establish by measuring  $x$  distances from T.S. and  $y$  distances from tangent. Compute  $\theta$  for each point and then compute  $x$  and  $y$  coordinates from Table 12, p. 224, or use  $\frac{1}{4}$  point formulas above.

Method III: Deflection angle from T.S. or S.T. to any point on spiral with coordinates  $x$  and  $y$  is the angle whose tangent =  $y/x$ .

Method IV: Deflection angles from T.S. to points of 10 equal divisions (10 chord spiral) are:  $0.01\phi_c$ ;  $0.04\phi_c$ ;  $0.16\phi_c$ ;  $0.25\phi_c$ ;  $0.36\phi_c$ ;  $0.49\phi_c$ ;  $0.64\phi_c$ ;  $0.81\phi_c$  and  $\phi_c$ .

TABLE 11. MINIMUM TRANSITION LENGTHS

$D_c$	30	40	50	60	70	$D_c$
	M.P.H.	M.P.H.	M.P.H.	M.P.H.	M.P.H.	
	$L_s$	$L_s$	$L_s$	$L_s$	$L_s$	
$1^\circ 30'$	150'	150'	150'	150'	150'	$1^\circ 30'$
$2^\circ$	150'	150'	150'	150'	200'	$2^\circ$
$2^\circ 30'$	150'	150'	150'	150'	250'	$2^\circ 30'$
$3^\circ$	150'	150'	150'	150'	300'	$3^\circ$
$3^\circ 30'$	150'	150'	150'	200'	350'	$3^\circ 30'$
$4^\circ$	150'	150'	150'	250'	400'	$4^\circ$
$5^\circ$	150'	150'	150'	300'		
$6^\circ$	150'	150'	200'	350'		
$7^\circ$	150'	150'	250'			
$8^\circ-9^\circ$	150'	150'	300'			
$10^\circ-12^\circ$	150'	200'				
$13^\circ-14^\circ$	150'	250'				
$15^\circ-23^\circ$	150'					
$24^\circ$	200'					

Based on  

$$L_s = \frac{1.6V^3}{R_c}$$
 Where:  $V = 0.75$  design speed in M.P.H.  
 Min.  $L_s = 150$  ft.

INSERTION OF SPIRALS INTO EXISTING ALIGNMENT OF CIRCULAR CURVES

$L_s$  = Length of spiral select from table 11, page 219

$\theta_s$  = Spiral angle =  $\frac{L_s D_c}{200}$ , where  $D_c$  = Degree of curvature (arc definition).

$P$  = Offset of curve at P.C. to permit spiral introduction from table, page 224 knowing  $\theta_s$ .

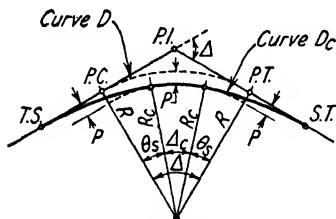

CASE I - Radius of original circular curve reduced by value of "P" to provide space to insert spiral transition.

1st trial : Assume  $D_c = D$ , find trial "P" as above.  
2nd trial : Compute  $D_c = \frac{5727.58}{R_c}$ , find correct "P"

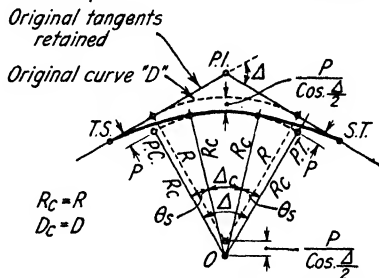

CASE II - Radius of original curve retained and curve center "O" shifted inward.

Note : Degree of curve retained.

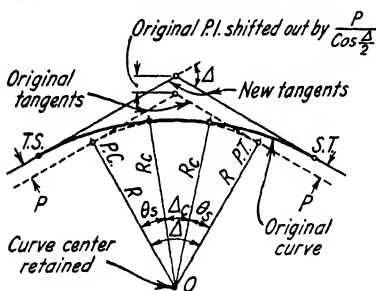

CASE III - Original circular curve location retained and tangents shifted outward to insert spiral.

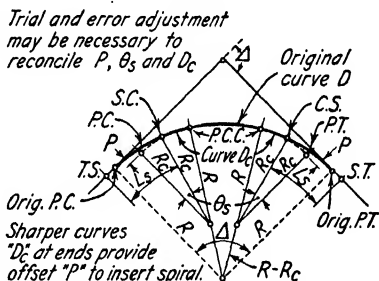

CASE IV - Original alignment retained as closely as possible by compounding circular curve at both ends.

$\theta_a$  = Equivalent spiral angle. Use in table on page 224 to find "P<sub>a</sub>".

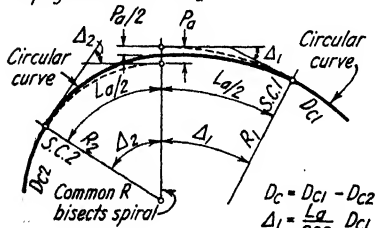

CASE V - To insert a spiral in a compound curve.

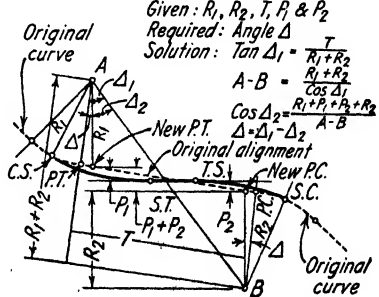

CASE VI - To insert spirals between simple reverse curves separated by a tangent.

PROPERTIES AND EXAMPLES \*

PROPERTIES OF SPIRAL

1. Offsets,  $y$ , vary as the cube of  $L$ , or length of spiral.  $\therefore y$  at any point =  $(L/L_s)^3 y_c$ . See Fig. 11.
2. Spiral angle  $\theta$  varies as  $L^2$ .  $\therefore \theta$  at any point on spiral =  $(L/L_s)^2 \theta_s$ .
3. Deflection angle  $\phi$  varies as  $L^2$ .  $\therefore \phi = (L/L_s)^2 \phi_c$ .  $\phi_c = \frac{1}{3} \theta_s - c$ ,  $c$  being a constant; see Table 10, p. 219. (May be neglected for ordinary problems.)
4.  $D$ , or degree of curve of spiral at any point, varies directly as  $L$ .  $\therefore D = L/L_s D_c$ .
5. Spiral bisects  $P$  very nearly and  $k$  approximately =  $\frac{1}{2} L_s$ .  $\therefore$  Offset from circular curve or tangent to midpoint of spiral is  $\frac{1}{2} P$  very nearly.
6. Spiral departs from the circular curve between S.C. and P.C. at the same rate as from the tangent.  $\therefore$  Radial offsets from circular curve between S.C. and P.C. to the spiral are the same as perpendicular offsets from the tangent between T.S. and P.C.

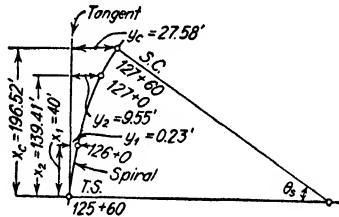

Given. Spiral  $L_s = 200'$ ;  $\theta_s = 24^\circ$ ; T.S. at Sta.  $125 + 60$ .

Required. Offsets to even stations.

Solution. Compute  $\theta$  and read  $x$  and  $y$  for  $L_s = 1$  from table on 224.

Sta.	$L$	$\theta$	$x, L_s = 1$	$y, L_s = 1$	$x$	$y$
126 + 0	40	$0^\circ 58'$	0.99997	0.00559	40.0	0.22
127 + 0	140	$11^\circ 46'$	0.99578	0.06821	139.41	9.55
127 + 60	200	$24^\circ 0'$	0.98260	0.13789	196.52	28.58

FIG. 11. Offsets to even stations.

\* Reference Transition Curves for Highways by Joseph Barnett, P.R.A.



## TRANSITION CURVES

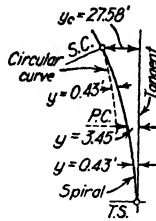

Given. Spiral,  $L_s = 200'$ ;  $\theta_s = 24^\circ$ .

Required. Offsets to  $\frac{1}{4}$  points.

Solution. From Fig. 11,  $y_c = 27.58'$ . By formula,  $y$  at any point =  $(L/L_s)^2 y_c$

At  $\frac{1}{4}$  points,  $y = 27.58 \times \frac{1}{64} = 0.43'$ .

At  $\frac{1}{2}$  points,  $y = 27.58 \times \frac{1}{8} = 3.45'$ .

FIG. 12. Offsets to  $\frac{1}{4}$  points.

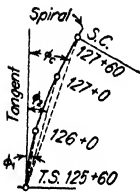

Given. Spiral with  $L_s = 200'$  and  $\theta_s = 24^\circ$ .

Required. Deflection angles  $\phi$ , to Sta. 126 + 0;  $\phi_2$  to Sta. 127 + 0;  $\phi_c$  to Sta. 127 + 60.

Solution. By formulas,  $\phi_c = \theta_s/3 - c$  and  $\phi = \frac{1}{3}(L/L_s)^2 \theta_s - c$ .

Sta. 127 + 60:  $\phi_c = 24/3 - 0.8 = 7.9866^\circ = 7^\circ 59.2'$

Sta. 126 + 00:  $\phi_1 = (L/L_s)^2 \phi_c = (40/200)^2 \times 7.9866$   
 $= 0.3195^\circ = 0^\circ 19'$

Sta. 127 + 00:  $\phi_2 = (L/L_s)^2 \phi_c = (140/200)^2 \times 7.9866$   
 $= 3.9134^\circ = 3^\circ 55'$

Layout. With transit at T.S., foresight along tangent with vernier at  $0^\circ$ . Turn  $\phi_1$  and measure 40 ft. to Sta. 126 + 0. Turn  $\phi_2$  and measure 100 ft. from Sta. 126 + 0 to Sta. 127 + 0. Turn  $\phi_c$  and measure 60' from Sta. 127 + 0 to S.C.

FIG. 13. Deflections to even stations.

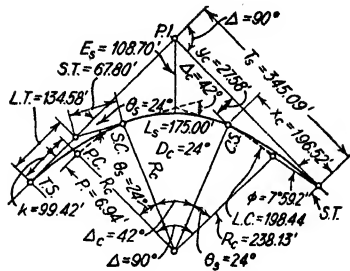

Given.  $\Delta = 90^\circ$ ;  $D_c = 24'$ ;  $L_s = 200'$ . Formulas from p. 217. Functions of spiral for  $L_s = .1$  from p. 224.  
 For layout of circular curve, see pp. 202, 203, 204.

LAYOUT OF CONTROL POINTS \*

Establish T.S. by measuring  $k$  from P.O.T. normal to P.C. or by  $T_s$  from P.I. Establish S.C. by L.T.,  $\theta_s$ , and S.T. or by  $x_c$  and  $y_c$  from T.S., or by  $\phi_c$  and L.C. from T.S.

Note. Figures 11-13 give all dimensions usually necessary to plot or locate the spiral. The following example is a curve fully worked out.

Required	Formula	Solution
$\theta_s$	$L_s D_c \div 200$	$\theta_s = 24^\circ$
$\Delta_c$	$\Delta - (L_s D_c \div 100)$	$\Delta_c = 42^\circ$
$L_c$	$100 \Delta_c \div D_c$	$L_c = 175.00$
$\phi_c$	$\frac{1}{3} \theta_s - c$	$\phi_c = 7^\circ 59.2'$
$y_c$	$(y \text{ for } L_s = 1) \cdot L_s$	$y_c = 27.58'$
$x_c$	$(x \text{ for } L_s = 1) \cdot L_s$	$x_c = 196.52'$
$P$	$y_c - R_c(1 - \cos \theta_s)$	$P = 6.94'$
$k$	$x_c - R_c \sin \theta_s$	$k = 99.42'$
$E_s$	$(R_c + P) \operatorname{exsec} \Delta/2 + P$	$E_s = 108.70'$
$T_s$	$(R_c + P) \tan \Delta/2 + k$	$T_s = 345.09'$
L.T.	$(L.T. \text{ for } L_s = 1)L_s; \theta = 24^\circ$	L.T. = 134.58'
S.T.	$(S.T. \text{ for } L_s = 1)L_s; \theta = 24^\circ$	S.T. = 67.80'
L.C.	$(L.C. \text{ for } L_s = 1)L_s; \theta = 24^\circ$	L.C. = 198.44

FIG. 14. Computations for spiral transitions to circular curves.

\* Adapted from O'Rourke, *General Engineering Handbook*, McGraw-Hill.

TABLE 12. FUNCTIONS OF TRANSITION FOR  $L_s = 1^*$ 

Enter table with value of  $\theta$  or  $\theta_s$ , and multiply function by  $L$  or  $L_s$ . See pp. 218-223 for use of table.

$\theta$	$p$	$k$	$x$	$y$	L.T.	S.T.	L.C.	$\theta$
0°	.00000	.50000	1.00000	.00000	.66667	.33333	1.00000	0°
1°	.00146	.49999	.99997	.00582	.66668	.33334	.99999	1°
2°	.00291	.49998	.99988	.01163	.66671	.33337	.99995	2°
3°	.00435	.49995	.99973	.01745	.66676	.33342	.99988	3°
4°	.00581	.49992	.99951	.02326	.66684	.33349	.99978	4°
5°	.00727	.49987	.99924	.02907	.66693	.33358	.99966	5°
6°	.00872	.49982	.99890	.03488	.66705	.33368	.99951	6°
7°	.01018	.49975	.99851	.04068	.66719	.33381	.99934	7°
8°	.01163	.49967	.99805	.04648	.66735	.33395	.99913	8°
9°	.01308	.49959	.99754	.05227	.66753	.33412	.99890	9°
10°	.01453	.49949	.99696	.05805	.66773	.33430	.99865	10°
11°	.01598	.49939	.99632	.06383	.66796	.33451	.99836	11°
12°	.01743	.49927	.99562	.06959	.66821	.33473	.99805	12°
13°	.01887	.49914	.99486	.07535	.66847	.33498	.99771	13°
14°	.02032	.49901	.99405	.08110	.66877	.33524	.99735	14°
15°	.02176	.49886	.99317	.08684	.66908	.33553	.99696	15°
16°	.02320	.49870	.99223	.09257	.66941	.33583	.99654	16°
17°	.02465	.49854	.99123	.09828	.66977	.33615	.99609	17°
18°	.02608	.49836	.99018	.10398	.67015	.33650	.99562	18°
19°	.02752	.49817	.98906	.10967	.67055	.33687	.99512	19°
20°	.02896	.49798	.98788	.11535	.67097	.33725	.99460	20°
21°	.03040	.49777	.98665	.12101	.67142	.33766	.99404	21°
22°	.03183	.49755	.98536	.12665	.67189	.33809	.99346	22°
23°	.03326	.49733	.98401	.13228	.67238	.33854	.99286	23°
24°	.03469	.49709	.98260	.13789	.67290	.33901	.99222	24°
25°	.03611	.49684	.98113	.14348	.67344	.33950	.99157	25°
26°	.03753	.49658	.97960	.14905	.67400	.34001	.99088	26°
27°	.03896	.49632	.97802	.15461	.67459	.34055	.99017	27°
28°	.04037	.49605	.97638	.16014	.67520	.34111	.98943	28°
29°	.04179	.49576	.97469	.16565	.67584	.34169	.98866	29°
30°	.04321	.49546	.97293	.17114	.67650	.34229	.98787	30°
31°	.04462	.49516	.97112	.17661	.67719	.34292	.98705	31°
32°	.04602	.49484	.96926	.18206	.67790	.34356	.98621	32°
33°	.04743	.49452	.96733	.18748	.67863	.34424	.98534	33°
34°	.04883	.49419	.96536	.19288	.67939	.34493	.98444	34°
35°	.05023	.49385	.96332	.19826	.68018	.34565	.98351	35°
36°	.05163	.49349	.96124	.20361	.68100	.34640	.98257	36°
37°	.05301	.49313	.95910	.20893	.68184	.34717	.98159	37°
38°	.05441	.49276	.95690	.21423	.68271	.34796	.98059	38°
39°	.05579	.49238	.95466	.21949	.68360	.34878	.97956	39°
40°	.05718	.49199	.95235	.22473	.68452	.34962	.97851	40°
41°	.05855	.49159	.95000	.22994	.68547	.35049	.97743	41°
42°	.05993	.49118	.94759	.23513	.68645	.35139	.97632	42°
43°	.06130	.49075	.94513	.24028	.68746	.35232	.97519	43°
44°	.06267	.49032	.94262	.24540	.68850	.35327	.97404	44°
45°	.06403	.48990	.94005	.25049	.68957	.35424	.97285	45°
46°	.06538	.48945	.93744	.25555	.69066	.35525	.97165	46°
47°	.06674	.48900	.93477	.26057	.69179	.35629	.97041	47°
48°	.06809	.48855	.93206	.26556	.69295	.35735	.96916	48°
49°	.06944	.48805	.92930	.27052	.69414	.35844	.96787	49°
50°	.07078	.48757	.92649	.27544	.69536	.35957	.96656	50°

\* Adapted from *Transition Curves for Highways* by Joseph Barnett, P.R.A.

TABLE 13. FUNCTIONS OF CURVES TRANSITIONAL THROUGHOUT  
TANGENTS AND EXTERNALS FOR  $L_s = 1^*$

$\Delta^\circ$	$T_s$	$E_s$	$\Delta^\circ$	$T_s$	$E_s$	$\Delta^\circ$	$T_s$	$E_s$
6°	1.00064	0.01747	38°	1.02682	0.11599	70°	1.10214	0.24203
7	1.00087	0.02040	39	1.02832	0.11936	71	1.10561	0.24681
8	1.00114	0.02332	40	1.02987	0.12275	72	1.10917	0.25167
9	1.00144	0.02625	41	1.03146	0.12617	73	1.11281	0.25660
10	1.00178	0.02918	42	1.03310	0.12962	74	1.11654	0.26161
11	1.00216	0.03213	43	1.03479	0.13309	75	1.12036	0.26669
12	1.00257	0.03507	44	1.03653	0.13660	76	1.12427	0.27186
13	1.00302	0.03802	45	1.03831	0.14012	77	1.12828	0.27710
14	1.00350	0.04098	46	1.04015	0.14370	78	1.13240	0.28244
15	1.00402	0.04396	47	1.04204	0.14730	79	1.13661	0.28786
16	1.00458	0.04693	48	1.04399	0.15094	80	1.14092	0.29337
17	1.00518	0.04992	49	1.04598	0.15460	81	1.14535	0.29898
18	1.00581	0.05292	50	1.04804	0.15831	82	1.14988	0.30468
19	1.00648	0.05593	51	1.05014	0.16206	83	1.15453	0.31048
20	1.00719	0.05895	52	1.05230	0.16584	84	1.15930	0.31639
21	1.00794	0.06198	53	1.05452	0.16966	85	1.16418	0.32241
22	1.00873	0.06502	54	1.05680	0.17352	86	1.16919	0.32854
23	1.00955	0.06808	55	1.05913	0.17742	87	1.17433	0.33478
24	1.01042	0.07115	56	1.06153	0.18137	88	1.17960	0.34115
25	1.01132	0.07424	57	1.06399	0.18536	89	1.18500	0.34763
26	1.01226	0.07734	58	1.06651	0.18940	90	1.19054	0.35425
27	1.01324	0.08045	59	1.06909	0.19348	91	1.19623	0.36099
28	1.01427	0.08358	60	1.07174	0.19762	92	1.20207	0.36788
29	1.01533	0.08674	61	1.07446	0.20181	93	1.20806	0.37490
30	1.01644	0.08990	62	1.07724	0.20604	94	1.21421	0.38207
31	1.01758	0.09309	63	1.08010	0.21034	95	1.22052	0.38940
32	1.01877	0.09630	64	1.08302	0.21468	96	1.22700	0.39688
33	1.02000	0.09952	65	1.08602	0.21908	97	1.23366	0.40453
34	1.02128	0.10277	66	1.08909	0.22355	98	1.24050	0.41234
35	1.02260	0.10604	67	1.09228	0.22807	99	1.24753	0.42034
36	1.02396	0.10933	68	1.09546	0.23266	100	1.25475	0.42852
37	1.02537	0.11265	69	1.09876	0.23731			

\* Adapted from *Transition Curves for Highways* by Joseph Barnett, P.R.A.

*Case VII.* Given  $\Delta$  and an external or tangent distance; to determine a curve transitional throughout.

Enter Table 13 at known  $\Delta$  and read  $T_s$  and  $E_s$  values. Then  $L_s = E_s/E_s$  value and  $T_s = L_s \cdot$  tangent value, or  $L_s = T_s/T_s$  value and  $E_s = L_s \cdot$  external value.

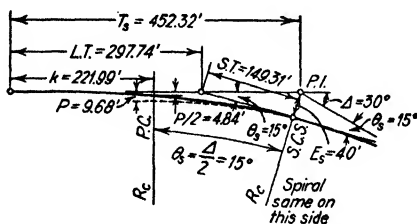

**EXAMPLE.** Given.  $\Delta = 30^\circ$  and  $E_s = 40'$ .

*Required.*  $L_s$ ,  $T_s$ ,  $\theta_s$ , L.T., S.T.,  $D_c$ ,  $P$ , and  $k$ .

*Solution.*  $L_s = 40 \div 0.08990 = 444.9$ , say  $445'$ .  $T_s = 1.01644 \times 445 = 452.32'$ .  $\theta_s = \frac{\Delta}{2} = 15^\circ$ .  $D_c = \frac{200\theta_s}{L_s} = 6.47'$ . L.T. =  $0.66908 \times 445 = 297.74'$ . S.T. =  $0.33553 \times 445 = 149.31'$ .  $p = 0.02176 \times 445 = 9.68'$ .  $k = 498.86 \times 445 = 221.99'$ .

FIG. 15. Spiral layout by offsets or deflections (same as for spiral transitions to a circular curve).

VERTICAL CURVES (Parabolic)

FORMULAS

$A$  = algebraic difference of grades =  $+g_1\% - (-g_2\%)$ .

$e = AL/8$ .

$d = l^2A/2L$ ;  $d = 4e (l/L)^2$ .

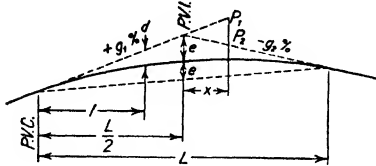

VERTICAL SUMMIT CURVE

Length of vertical summit curves should provide required sight distance. See Vol. I, p. 3-60.

Note. All horizontal distances shown on this page— $L, l, l_1, l_2, x, x_1, x_2$ —are expressed in 100 ft. stations.

Where  $L$ , length of vertical curve, is not determined by sight distance criteria, the minimum value for comfort is

$$L = \frac{AV^2}{10,000} *$$

EXAMPLE. Given.  $g_1\% = +3.00\%$ ;  $g_2\% = -2.00\%$ ;  $L = 3.00$ ;  $l = 0.50$ .

Required.  $A, e$ , and  $d$ .

Solution.

$$A = 3.00 - (-2.00) = 5.00$$

$$e = \frac{5.00 \times 3.00}{8} = 1.875'$$

$$d = \frac{0.50^2 \times 5.00}{2 \times 3.00} = 0.208'$$

Also,

$$d = 4(1.875) \left( \frac{0.50}{3.00} \right)^2 = 0.208'$$

To find Sta. of P.V.I. when elevations of  $P_1$  and  $P_2$  are known.

FORMULA

$$x = \frac{\text{elev. } P_1 - \text{elev. } P_2}{A}$$

EXAMPLE. Given. Elev.  $P_1 = 154.50$ ; elev.  $P_2 = 150.00$ ;  $A = 5.00$ .

Required.  $x$  = distance in 100' stations from known point to P.V.I.

\* From O'Rourke, *General Engineering Handbook*, McGraw-Hill.

*Solution.*

$$x = \frac{154.50 - 150.00}{5.00} = 0.90(100' \text{ stations})$$

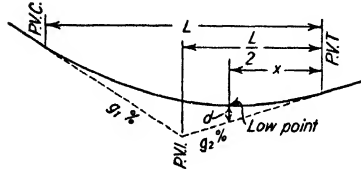

*To find low point on sag curve.*

#### VERTICAL SAG CURVE

Length of vertical sag curve should provide headlight illumination for a safe stopping distance. See Vol. I, p. 3-62.

#### FORMULAS

$$x = g(\text{lesser gradient}) L/A.$$

$$d(\text{at low point}) = x^2 A/2L.$$

**EXAMPLE.** *Given.*  $g_1\%$  =  $-3.00\%$ ;  $g_2\%$  =  $+2.00\%$ ;  $L$  = 3.00;  $A$  = 5.00.

*Required.*  $x$  and  $d$ .

*Solution.*

$$x = 2.00 \times \frac{3.00}{5.00} = 1.20'$$

$$d = \frac{1.20^2 \times 5.00}{2 \times 3.00} = 1.20'$$

*Note.* High point on summit curve can be found by same method.

FIG. 16. Symmetrical vertical curves.

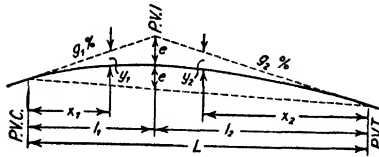

FORMULAS

$$e = \frac{l_1 l_2}{2(l_1 + l_2)} (g_1 - g_2); y_1 = e \left( \frac{x_1}{l_1} \right)^2; y_2 = e \left( \frac{x_2}{l_2} \right)^2$$

EXAMPLE. Given.  $g_1 = 3.00\%$ ;  $g_2 = 2.00\%$ ;  $L = 4.00$ ;  $l_1 = 1.50$ ;  $l_2 = 2.50$ ;  $x_1 = 0.50$ ;  $x_2 = 1.00$ .

Required.  $e$ ,  $y_1$ , and  $y_2$ .

Solution.

$$e = \frac{1.50 \times 2.50}{2(1.50 + 2.50)} (3.00 + 2.00) = 2.35'$$

$$y_1 = 2.35 \left( \frac{0.50}{1.50} \right)^2 = 0.26'$$

$$y_2 = 2.35 \left( \frac{1.00}{2.50} \right)^2 = 0.38'$$

FIG. 17. Unsymmetrical vertical curves used to fit unusual conditions.

PARABOLIC CROWN ORDINATES

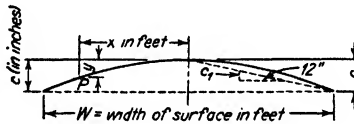

FORMULAS

SYMMETRICAL CROWN

Used for roads and for streets where gutters are same elevation.

$$c = c_1 \left( \frac{W}{2} \right); y = 4c \left( \frac{x}{W} \right)^2.$$

EXAMPLE. Given.  $c_1 = \frac{1}{8}''$ ;  $W = 22'$ ; and  $x = 6'$ .

Required.  $c$ ;  $y$  (at any point  $P$ ).

Solution.

$$c = \frac{1}{8} \times 22\frac{1}{2} = 1.375'' = 1\frac{3}{8}''$$

$$y = 4 \times 1.375 \left( \frac{6}{22} \right)^2 = 0.409'' = 13\frac{1}{2}''$$



ORDINATES—ANY PARABOLIC CURVE

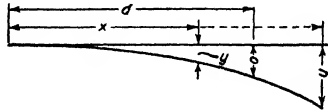

UNSYMMETRICAL CROWN

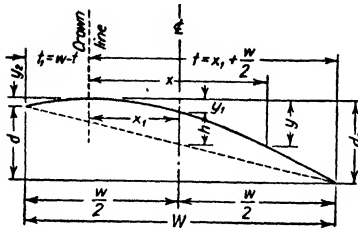

Used for city streets where conditions necessitate different gutter elevations. If slope per foot is over 1/2 in., a stepped curb or retaining wall should be used on uphill side of street.

Also used for off-center crowns on three-lane roads to provide symmetrical crown for future four lanes.

Also used for transition onto superelevated curves.

Offsets from tangent to curve vary directly as the squares of the tangent distances.

FORMULA

$$d^2 : x^2 = o : y. \therefore y = \frac{ox^2}{d^2}.$$

EXAMPLE. Given.  $d = 10'$ ;  $o = 6''$ ; and  $x = 5'$ .

Required.  $y$ .

Solution.

$$y = \frac{6 \times 5^2}{10^2} = 1.50'' = 1\frac{1}{2}''$$

ALTERNATIVE METHOD

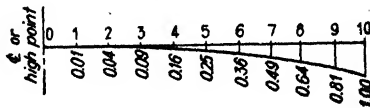

Divide the distance from center line or high point to edge of pavement into 10 equal spaces. Multiply figures in chart by total crown to get ordinates from crown elevation to pavement surface for points shown.

EXAMPLE. *Given.* Total crown = 6".

*Required.* Ordinates at fifth and eighth points.

*Solution.*

Ordinate at fifth point =  $0.25 \times 6 = 1.50'' = 1\frac{1}{2}''$ .

Ordinate at eighth point =  $0.64 \times 6 = 3.84'' = 3\frac{13}{16}''$ .

#### FORMULAS

$$x_1 = \frac{dw}{8h}; y_1 = \frac{d^2}{16h}; d_1 = \frac{d}{2} + h + y_1; y = \frac{d_1 x^2}{t^2}$$

$$y_2 = d_1 - d; t = x_1 + \frac{w}{2}; t_1 = W - t$$

EXAMPLE. *Given.*  $h = 0.5'$ ;  $w = 40'$ ;  $d = 0.5'$ ;  $x = 10'$ .

*Required.*  $x_1$ ;  $y_1$ ;  $d_1$ ;  $y_2$ ;  $y$ ;  $t$  and  $t_1$ .

*Solution.*

$$x_1 = \frac{0.5 \times 40}{8 \times 0.5} = 5.0'$$

$$y_1 = \frac{0.5^2}{16 \times 0.5} = 0.0312' = 0.375'' = \frac{3}{8}''$$

$$d_1 = \frac{0.5}{2} + 0.5 + 0.0312 = 0.7812' = 9.375'' = 9\frac{3}{8}''$$

$$y_2 = 0.7812 - 0.5 = 0.2812' = 3.375'' = 3\frac{3}{8}''$$

$$t = 5.0 + \frac{40}{2} = 25.0'$$

$$y = \frac{0.7812 \times 10^2}{25^2} = 0.125'' = 1\frac{1}{2}''$$

$$t_1 = 40 - 25 = 15'$$

VERTICAL CURVES

TABLE 14. PARABOLIC CROWN ORDINATES  
 ORDINATES FROM GRADE TANGENT TO SURFACE FOR EACH FOOT OF WIDTH  
 SURFACE WIDTH OF STREET OR ROAD

20'		22'		34'		40'		44'		60'	
3/8":1' Crown		3/8":1' Crown		3/8":1' Crown		3/8":1' Crown		3/8":1' Crown		3/8":1' Crown	
1	.004	.003	.003	0"	.000	0"	.000	0"	.000	0"	.000
2	3/16"	3/16"	.005	1/16"	3/16"	1/16"	3/16"	1/16"	3/16"	1/16"	3/16"
3	3/16"	.011	.005	3/16"	.011	3/16"	.011	3/16"	.011	3/16"	.011
4	3/16"	.026	.011	3/8"	.026	3/8"	.026	3/8"	.026	3/8"	.026
5	3/16"	.045	.020	1/2"	.045	1/2"	.045	1/2"	.045	1/2"	.045
6	3/16"	.067	.031	5/8"	.067	5/8"	.067	5/8"	.067	5/8"	.067
7	3/16"	.094	.044	1"	.094	1"	.094	1"	.094	1"	.094
8	3/16"	.126	.060	1 1/8"	.126	1 1/8"	.126	1 1/8"	.126	1 1/8"	.126
9	3/16"	.164	.078	1 1/4"	.164	1 1/4"	.164	1 1/4"	.164	1 1/4"	.164
10	3/16"	.204	.099	1 1/2"	.204	1 1/2"	.204	1 1/2"	.204	1 1/2"	.204
11	3/16"	.247	.123	1 3/4"	.247	1 3/4"	.247	1 3/4"	.247	1 3/4"	.247
12	3/16"	.294	.148	2"	.294	2"	.294	2"	.294	2"	.294
13	3/16"	.344	.176	2 1/8"	.344	2 1/8"	.344	2 1/8"	.344	2 1/8"	.344
14	3/16"	.397	.207	2 1/4"	.397	2 1/4"	.397	2 1/4"	.397	2 1/4"	.397
15	3/16"	.454	.241	2 1/2"	.454	2 1/2"	.454	2 1/2"	.454	2 1/2"	.454
16	3/16"	.514	.279	2 3/4"	.514	2 3/4"	.514	2 3/4"	.514	2 3/4"	.514
17	3/16"	.577	.321	3"	.577	3"	.577	3"	.577	3"	.577
18	3/16"	.643	.354	3 1/8"	.643	3 1/8"	.643	3 1/8"	.643	3 1/8"	.643
19	3/16"	.712	.393	3 1/4"	.712	3 1/4"	.712	3 1/4"	.712	3 1/4"	.712
20	3/16"	.784	.437	3 1/2"	.784	3 1/2"	.784	3 1/2"	.784	3 1/2"	.784
21	3/16"	.858	.485	3 3/4"	.858	3 3/4"	.858	3 3/4"	.858	3 3/4"	.858
22	3/16"	.934	.537	4"	.934	4"	.934	4"	.934	4"	.934
23	3/16"	1.012	.593	4 1/8"	1.012	4 1/8"	1.012	4 1/8"	1.012	4 1/8"	1.012
24	3/16"	1.092	.653	4 1/4"	1.092	4 1/4"	1.092	4 1/4"	1.092	4 1/4"	1.092
25	3/16"	1.174	.717	4 1/2"	1.174	4 1/2"	1.174	4 1/2"	1.174	4 1/2"	1.174
26	3/16"	1.258	.784	4 3/4"	1.258	4 3/4"	1.258	4 3/4"	1.258	4 3/4"	1.258
27	3/16"	1.344	.854	5"	1.344	5"	1.344	5"	1.344	5"	1.344
28	3/16"	1.432	.927	5 1/8"	1.432	5 1/8"	1.432	5 1/8"	1.432	5 1/8"	1.432
29	3/16"	1.522	1.002	5 1/4"	1.522	5 1/4"	1.522	5 1/4"	1.522	5 1/4"	1.522
30	3/16"	1.614	1.079	5 1/2"	1.614	5 1/2"	1.614	5 1/2"	1.614	5 1/2"	1.614
31	3/16"	1.708	1.159	5 3/4"	1.708	5 3/4"	1.708	5 3/4"	1.708	5 3/4"	1.708
32	3/16"	1.804	1.241	6"	1.804	6"	1.804	6"	1.804	6"	1.804
33	3/16"	1.902	1.325	6 1/8"	1.902	6 1/8"	1.902	6 1/8"	1.902	6 1/8"	1.902
34	3/16"	2.002	1.411	6 1/4"	2.002	6 1/4"	2.002	6 1/4"	2.002	6 1/4"	2.002
35	3/16"	2.104	1.499	6 1/2"	2.104	6 1/2"	2.104	6 1/2"	2.104	6 1/2"	2.104
36	3/16"	2.208	1.589	6 3/4"	2.208	6 3/4"	2.208	6 3/4"	2.208	6 3/4"	2.208
37	3/16"	2.314	1.681	7"	2.314	7"	2.314	7"	2.314	7"	2.314
38	3/16"	2.422	1.775	7 1/8"	2.422	7 1/8"	2.422	7 1/8"	2.422	7 1/8"	2.422
39	3/16"	2.532	1.871	7 1/4"	2.532	7 1/4"	2.532	7 1/4"	2.532	7 1/4"	2.532
40	3/16"	2.644	1.969	7 1/2"	2.644	7 1/2"	2.644	7 1/2"	2.644	7 1/2"	2.644
41	3/16"	2.758	2.069	7 3/4"	2.758	7 3/4"	2.758	7 3/4"	2.758	7 3/4"	2.758
42	3/16"	2.874	2.171	8"	2.874	8"	2.874	8"	2.874	8"	2.874
43	3/16"	2.992	2.275	8 1/8"	2.992	8 1/8"	2.992	8 1/8"	2.992	8 1/8"	2.992
44	3/16"	3.112	2.381	8 1/4"	3.112	8 1/4"	3.112	8 1/4"	3.112	8 1/4"	3.112
45	3/16"	3.234	2.489	8 1/2"	3.234	8 1/2"	3.234	8 1/2"	3.234	8 1/2"	3.234
46	3/16"	3.358	2.599	8 3/4"	3.358	8 3/4"	3.358	8 3/4"	3.358	8 3/4"	3.358
47	3/16"	3.484	2.711	9"	3.484	9"	3.484	9"	3.484	9"	3.484
48	3/16"	3.612	2.825	9 1/8"	3.612	9 1/8"	3.612	9 1/8"	3.612	9 1/8"	3.612
49	3/16"	3.742	2.941	9 1/4"	3.742	9 1/4"	3.742	9 1/4"	3.742	9 1/4"	3.742
50	3/16"	3.874	3.059	9 1/2"	3.874	9 1/2"	3.874	9 1/2"	3.874	9 1/2"	3.874
51	3/16"	4.008	3.179	9 3/4"	4.008	9 3/4"	4.008	9 3/4"	4.008	9 3/4"	4.008
52	3/16"	4.144	3.299	10"	4.144	10"	4.144	10"	4.144	10"	4.144
53	3/16"	4.282	3.421	10 1/8"	4.282	10 1/8"	4.282	10 1/8"	4.282	10 1/8"	4.282
54	3/16"	4.422	3.545	10 1/4"	4.422	10 1/4"	4.422	10 1/4"	4.422	10 1/4"	4.422
55	3/16"	4.564	3.671	10 1/2"	4.564	10 1/2"	4.564	10 1/2"	4.564	10 1/2"	4.564
56	3/16"	4.708	3.799	10 3/4"	4.708	10 3/4"	4.708	10 3/4"	4.708	10 3/4"	4.708
57	3/16"	4.854	3.929	11"	4.854	11"	4.854	11"	4.854	11"	4.854
58	3/16"	4.992	4.059	11 1/8"	4.992	11 1/8"	4.992	11 1/8"	4.992	11 1/8"	4.992
59	3/16"	5.132	4.191	11 1/4"	5.132	11 1/4"	5.132	11 1/4"	5.132	11 1/4"	5.132
60	3/16"	5.274	4.325	11 1/2"	5.274	11 1/2"	5.274	11 1/2"	5.274	11 1/2"	5.274
61	3/16"	5.418	4.461	11 3/4"	5.418	11 3/4"	5.418	11 3/4"	5.418	11 3/4"	5.418
62	3/16"	5.564	4.599	12"	5.564	12"	5.564	12"	5.564	12"	5.564
63	3/16"	5.712	4.739	12 1/8"	5.712	12 1/8"	5.712	12 1/8"	5.712	12 1/8"	5.712
64	3/16"	5.862	4.881	12 1/4"	5.862	12 1/4"	5.862	12 1/4"	5.862	12 1/4"	5.862
65	3/16"	6.014	5.025	12 1/2"	6.014	12 1/2"	6.014	12 1/2"	6.014	12 1/2"	6.014
66	3/16"	6.168	5.171	12 3/4"	6.168	12 3/4"	6.168	12 3/4"	6.168	12 3/4"	6.168
67	3/16"	6.324	5.319	13"	6.324	13"	6.324	13"	6.324	13"	6.324
68	3/16"	6.482	5.469	13 1/8"	6.482	13 1/8"	6.482	13 1/8"	6.482	13 1/8"	6.482
69	3/16"	6.642	5.621	13 1/4"	6.642	13 1/4"	6.642	13 1/4"	6.642	13 1/4"	6.642
70	3/16"	6.804	5.775	13 1/2"	6.804	13 1/2"	6.804	13 1/2"	6.804	13 1/2"	6.804
71	3/16"	6.968	5.931	13 3/4"	6.968	13 3/4"	6.968	13 3/4"	6.968	13 3/4"	6.968
72	3/16"	7.134	6.089	14"	7.134	14"	7.134	14"	7.134	14"	7.134
73	3/16"	7.302	6.249	14 1/8"	7.302	14 1/8"	7.302	14 1/8"	7.302	14 1/8"	7.302
74	3/16"	7.472	6.411	14 1/4"	7.472	14 1/4"	7.472	14 1/4"	7.472	14 1/4"	7.472
75	3/16"	7.644	6.575	14 1/2"	7.644	14 1/2"	7.644	14 1/2"	7.644	14 1/2"	7.644
76	3/16"	7.818	6.741	14 3/4"	7.818	14 3/4"	7.818	14 3/4"	7.818	14 3/4"	7.818
77	3/16"	7.994	6.909	15"	7.994	15"	7.994	15"	7.994	15"	7.994
78	3/16"	8.172	7.079	15 1/8"	8.172	15 1/8"	8.172	15 1/8"	8.172	15 1/8"	8.172
79	3/16"	8.352	7.251	15 1/4"	8.352	15 1/4"	8.352	15 1/4"	8.352	15 1/4"	8.352
80	3/16"	8.534	7.425	15 1/2"	8.534	15 1/2"	8.534	15 1/2"	8.534	15 1/2"	8.534
81	3/16"	8.718	7.599	15 3/4"	8.718	15 3/4"	8.718	15 3/4"	8.718	15 3/4"	8.718
82	3/16"	8.904	7.775	16"	8.904	16"	8.904	16"	8.904	16"	8.904
83	3/16"	9.092	7.953	16 1/8"	9.092	16 1/8"	9.092	16 1/8"	9.092	16 1/8"	9.092
84	3/16"	9.282	8.133	16 1/4"	9.282	16 1/4"	9.282	16 1/4"	9.282	16 1/4"	9.282
85	3/16"	9.474	8.315	16 1/2"	9.474	16 1/2"	9.474	16 1/2"	9.474	16 1/2"	9.474
86	3/16"	9.668	8.499	16 3/4"	9.668	16 3/4"	9.668	16 3/4"	9.668	16 3/4"	9.668
87	3/16"	9.864	8.685	17"	9.864	17"	9.864	17"	9.864	17"	9.864
88	3/16"	10.062	8.873	17 1/8"	10.062	17 1/8"	10.062	17 1/8"	10.062	17 1/8"	10.062
89	3/16"	10.262	9.063	17 1/4"	10.262	17 1/4"	10.262	17 1/4"	10.262	17 1/4"	10.262
90	3/16"	10.464	9.255	17 1/2"	10.464	17 1/2"	10.464	17 1/2"	10.464	17 1/2"	10.464
91	3/16"	10.668	9.449	17 3/4"	10.668	17 3/4"	10.668	17 3/4"	10.668	17 3/4"	10.668
92	3/16"	10.874	9.645	18"	10.874	18"	10.874	18"	10.874	18"	10.874
93	3/16"	11.082	9.843	18 1/8"	11.082	18 1/8"	11.082	18 1			

# RAILROAD TURNOUTS AND CROSSOVERS

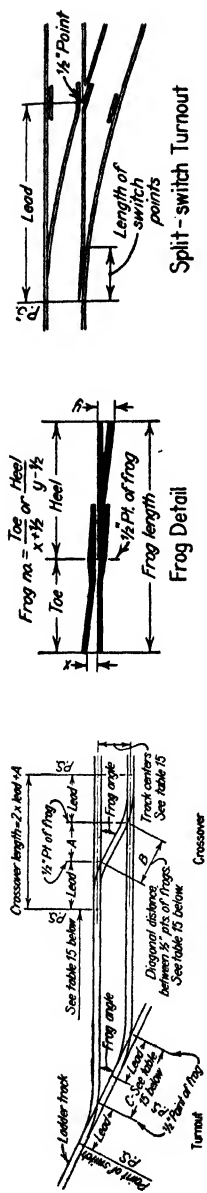

**TABLE 15. FROGS, SWITCHES, TURNOUTS, AND CROSSOVERS**

Frog Angle	Frog Length	Length of Switch Points	Switches	Turnouts and Crossovers																	
				Distance in Feet between Center Lines of Tracks. Gauge—4'-8 1/2"																	
				12'-0"			13'-0"			14'-0"			16'-0"			18'-0"					
A	B	C	A	B	C	A	B	C	A	B	C	A	B	C							
6 9°-31'-38"	11'-4 1/2"	11'-0"	Lead Distance from Pt. of Switch to 1/2" Pt. of Frog	48.19	14.50	16.23	72.50	20.46	22.07	78.54	26.42	28.00	84.58	38.33	39.96	96.07	50.24	51.97	108.75	.596	.604
7 8°-10'-16"	14'-7 1/2"	16'-8"		61.28	17.07	18.37	84.43	24.04	25.43	91.47	31.00	32.36	98.50	44.93	46.33	112.57	58.85	60.33	126.14	.696	.704
8 7°-09'-10"	15'-5"	16'-6"		67.14	19.63	20.83	96.37	27.60	28.82	104.40	35.57	36.76	112.44	51.51	52.73	128.50	67.45	68.75	144.56	.707	.804
9 6°-21'-35"	16'-3"	16'-6"		72.73	22.17	23.34	108.33	31.14	32.21	117.36	40.12	41.18	126.39	58.07	59.16	144.44	76.02	77.17	162.50	.898	.903
10 5°-43'-29"	17'-10 1/2"	16'-8"		77.61	24.71	25.76	120.30	34.68	35.65	130.33	44.66	45.61	140.35	64.61	65.59	160.40	84.56	85.60	180.45	.998	1.003
12 4°-46'-19"	20'-4"	16'-8"		97.25	29.76	30.84	144.25	41.73	42.64	156.27	53.71	54.51	168.29	77.67	78.49	192.33	101.62	102.49	216.37	1.198	1.202
14 4°-06'-27"	26'-7"	22'-0"		107.33	34.80	35.54	168.21	48.78	49.49	182.23	62.76	63.44	196.25	90.73	91.43	224.28	118.69	119.43	252.32	1.398	1.402
16 3°-34'-47"	26'-0"	30'-0"		131.36	39.82	40.87	192.19	55.81	56.42	208.21	71.79	72.39	224.23	103.76	104.37	256.26	135.73	136.38	288.29	1.598	1.602
18 3°-10'-56"	29'-3"	30'-0"		141.14	44.85	45.44	216.17	62.84	63.38	234.19	80.82	81.36	252.20	116.79	117.33	288.23	152.76	153.34	324.26	1.798	1.802

33  
33  
Frog No.

Columns A and C below amounts to tabular figures for every 0.1 ft. increase in distance between tracks.

## EARTHWORK COMPUTATIONS

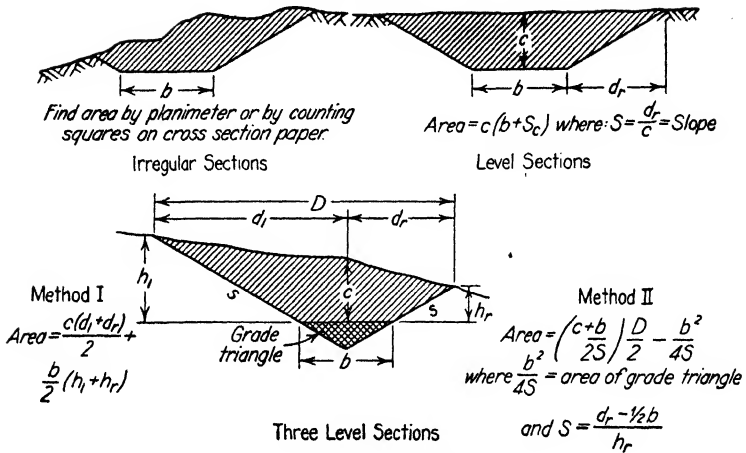

FIG. 18. Methods of finding areas.

1. By average end areas: \* Volume in cubic yards =  $\frac{A_0 + A_1}{2} \cdot \frac{l}{27}$ , where  $l$  = distance in feet between section  $A_0$  and  $A_1$ . Compute end areas as indicated in Fig. 18. Use Tables 16 and 17; also see example on p. 235.
2. By prismoidal formula: Volume in cubic yards =  $\frac{A_0 + 4M + A_1}{6} \cdot \frac{l}{27}$ , where  $l$  = distance in feet between sections  $A_0$  and  $A_1$ ,  $M$  = area at section midway between section  $A_0$  and  $A_1$ .
3. Using prismoidal corrections: Subtract volume in Table 18, p. 240, from volume found using average end areas method.
4. To find volume of excavation on curves use average end area method with  $l$  between sections as indicated below. Fill volumes can be computed similarly.

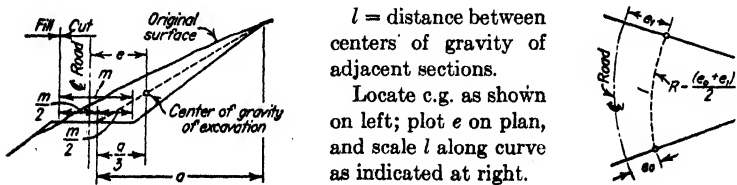
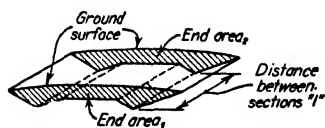

FIG. 19. Methods of finding volumes.

\* Used by most state highway departments and Public Roads Administration. Recommended for roads and airports.



EXAMPLE 1. *Given.* End area<sub>1</sub> = 97 sq. ft.; end area<sub>2</sub> = 120 sq. ft.;  
 $l = 50'$ .

*Required.* Cubic yards between sections.

*Solution.* D.A. =  $97 + 120 = 217$  sq. ft. Enter D.A. column, and to right of 217 find C.Y. = 201 in C.Y. column.

Use Table 17 for D.A. of from 500 to 1000 cu. yd.

EXAMPLE 2. *Given.* D.A. = 2751 sq. ft.;  $l = 50'$ .

*Required.* Cubic yards between stations.

*Solution.* D.A. of 2000 = 1852 cu. yd. Find at bottom of Table 16; D.A. of 751 sq. ft. = 695 cu. yd. Therefore cubic yards for D.A. of 2751 sq. ft. =  $1852 + 695 = 2547$  cu. yd.

EXAMPLE 3. When  $l$  is less than  $50'$ .

*Given.* D.A. = 217 sq. ft.;  $l = 37'$ .

*Required.* C.Y. between sections.

*Solution.* Enter column "Distance between Sections" and to right of 37 find "Constant" .6852. Then  $.6852 \times 217 = 149$  C.Y.

DOUBLE END AREA VOLUMES  
 TABLE 16. CUBIC YARDS FOR SUM OF END AREAS FOR DISTANCE BETWEEN STATIONS OF 50 FT. \*

		D.A. = sum of end areas in square feet.																Dis- tance between Sections	Con- stant		
D.A.	C.Y.	D.A.	C.Y.	D.A.	C.Y.	D.A.	C.Y.	D.A.	C.Y.	D.A.	C.Y.	D.A.	C.Y.	D.A.	C.Y.	D.A.	C.Y.				
0	0	50	46	100	93	150	139	200	185	250	231	300	278	350	324	400	370	450	417	0'	.0000
1	1	51	47	101	94	151	140	201	186	251	232	301	279	351	325	401	371	451	418	1'	.0185
2	2	52	48	102	94	152	141	202	187	252	233	302	280	352	326	402	372	452	419	2'	.0370
3	3	53	49	103	95	153	142	203	188	253	234	303	281	353	327	403	373	453	419	3'	.0556
4	4	54	50	104	96	154	143	204	189	254	235	304	281	354	328	404	374	454	420	4'	.0741
5	5	55	51	105	97	155	144	205	190	255	236	305	282	355	329	405	375	455	421	5'	.0926
6	6	56	52	106	98	156	144	206	191	256	237	306	283	356	330	406	376	456	422	6'	.1111
7	7	57	53	107	99	157	145	207	192	257	238	307	284	357	331	407	377	457	423	7'	.1296
8	8	58	54	108	100	158	146	208	193	258	239	308	285	358	331	408	378	458	424	8'	.1482
9	9	59	55	109	101	159	147	209	194	259	240	309	286	359	332	409	379	459	425	9'	.1667
10	10	60	56	110	102	160	148	210	194	260	241	310	287	360	333	410	380	460	426	10'	.1852
11	11	61	56	111	103	161	149	211	195	261	242	311	288	361	334	411	381	461	427	11'	.2037
12	12	62	57	112	104	162	150	212	196	262	243	312	289	362	335	412	381	462	428	12'	.2222
13	13	63	58	113	105	163	151	213	197	263	244	313	290	363	336	413	382	463	429	13'	.2407
14	14	64	59	114	106	164	152	214	198	264	244	314	291	364	337	414	383	464	430	14'	.2593
15	15	65	60	115	106	165	153	215	199	265	245	315	292	365	338	415	384	465	431	15'	.2778
16	16	66	61	116	107	166	154	216	200	266	246	316	293	366	339	416	385	466	431	16'	.2963
17	17	67	62	117	108	167	155	217	201	267	247	317	294	367	340	417	386	467	432	17'	.3148
18	18	68	63	118	109	168	156	218	202	268	248	318	294	368	341	418	387	468	433	18'	.3333
19	19	69	64	119	110	169	156	219	203	269	249	319	295	369	342	419	388	469	434	19'	.3519
20	20	70	65	120	111	170	157	220	204	270	250	320	296	370	343	420	389	470	435	20'	.3704
21	21	71	66	121	112	171	158	221	205	271	251	321	297	371	344	421	390	471	436	21'	.3889
22	22	72	67	122	113	172	159	222	206	272	252	322	298	372	344	422	391	472	437	22'	.4074

DOUBLE END AREA VOLUMES

23	123	114	173	160	223	206	273	253	323	299	373	345	423	392	473	438	23'
24	124	115	174	161	224	207	274	254	324	300	374	346	424	393	474	439	24'
25	125	116	175	162	225	208	275	255	325	301	375	347	425	394	475	440	25'
26	126	117	176	163	226	209	276	256	326	302	376	348	426	394	476	441	26'
27	127	118	177	164	227	210	277	257	327	303	377	349	427	395	477	442	27'
28	128	119	178	165	228	211	278	257	328	304	378	350	428	396	478	443	28'
29	129	119	179	166	229	211	279	258	329	305	379	351	429	397	479	444	29'
30	130	120	180	167	230	213	280	259	330	306	380	352	430	398	480	444	30'
31	131	121	181	168	231	214	281	260	331	307	381	353	431	399	481	445	31'
32	132	122	182	169	232	215	282	261	332	307	382	354	432	400	482	446	32'
33	133	123	183	169	233	216	283	262	333	308	383	355	433	401	483	447	33'
34	134	124	184	170	234	217	284	263	334	309	384	356	434	402	484	448	34'
35	135	125	185	171	235	218	285	264	335	310	385	356	435	403	485	449	35'
36	136	126	186	172	236	219	286	265	336	311	386	357	436	404	486	450	36'
37	137	127	187	173	237	219	287	266	337	312	387	358	437	405	487	451	37'
38	138	128	188	174	238	220	288	267	338	313	388	359	438	406	488	452	38'
39	139	129	189	175	239	221	289	268	339	314	389	360	439	406	489	453	39'
40	140	130	190	176	240	222	290	269	340	315	390	361	440	407	490	454	40'
41	141	131	191	177	241	223	291	269	341	316	391	362	441	408	491	455	41'
42	142	131	192	178	242	224	292	270	342	317	392	363	442	409	492	456	42'
43	143	132	193	179	243	225	293	271	343	318	393	364	443	410	493	456	43'
44	144	133	194	180	244	226	294	272	344	319	394	365	444	411	494	457	44'
45	145	134	195	181	245	227	295	273	345	319	395	366	445	412	495	458	45'
46	146	135	196	181	246	228	296	274	346	320	396	367	446	413	496	459	46'
47	147	136	197	182	247	229	297	275	347	321	397	368	447	414	497	460	47'
48	148	137	198	183	248	230	298	276	348	322	398	369	448	415	498	461	48'
49	149	138	199	184	249	231	299	277	349	323	399	369	449	416	499	462	49'
50																	50'

1000 = 926

2000 = 1852

3000 = 2778

4000 = 3704

5000 = 4630

\* Based on average end area formula. Not as accurate as prismoidal formula, but as accurate as usual field measurements warrant. Specified for payment quantities by most state highway departments.



EARTHWORK COMPUTATIONS

TABLE 17. CUBIC YARDS FOR SUM OF END AREAS FOR DISTANCE BETWEEN STATIONS OF 50 FT.\*

		D.A. = sum of end areas in square feet (double end areas).																Distance between Sections	Con-stant		
D.A.	C.Y.	D.A.	C.Y.	D.A.	C.Y.	D.A.	C.Y.	D.A.	C.Y.	D.A.	C.Y.	D.A.	C.Y.	D.A.	C.Y.	D.A.	C.Y.	D.A.	C.Y.	D.A.	C.Y.
500	463	550	509	600	556	650	602	700	648	750	694	800	741	850	787	900	833	950	880	0.0185	
501	464	551	510	601	556	651	603	701	649	751	695	801	742	851	788	901	834	951	881	0.0370	
502	465	552	511	602	557	652	604	702	650	752	696	802	743	852	789	902	835	952	881	0.0556	
503	466	553	512	603	558	653	605	703	651	753	697	803	744	853	790	903	836	953	882	0.0741	
504	467	554	513	604	559	654	606	704	652	754	698	804	744	854	791	904	837	954	883	0.0926	
505	468	555	514	605	560	655	606	705	653	755	699	805	745	855	792	905	838	955	884	0.1111	
506	469	556	515	606	561	656	607	706	654	756	700	806	746	856	793	906	839	956	885	0.1296	
507	469	557	516	607	562	657	608	707	655	757	701	807	747	857	794	907	840	957	886	0.1482	
508	470	558	517	608	563	658	609	708	656	758	702	808	748	858	794	908	841	958	887	0.1667	
509	471	559	518	609	564	659	610	709	656	759	703	809	749	859	795	909	842	959	888	0.1852	
510	472	560	519	610	565	660	611	710	657	760	704	810	750	860	796	910	843	960	889	0.2037	
511	473	561	519	611	566	661	612	711	658	761	705	811	751	861	797	911	844	961	890	0.2222	
512	474	562	520	612	567	662	613	712	659	762	706	812	752	862	798	912	844	962	891	0.2407	
513	475	563	521	613	568	663	614	713	660	763	706	813	753	863	799	913	845	963	892	0.2593	
514	476	564	522	614	569	664	615	714	661	764	707	814	754	864	800	914	846	964	893	0.2778	
515	477	565	523	615	569	665	616	715	662	765	708	815	755	865	801	915	847	965	894	0.2963	
516	478	566	524	616	570	666	617	716	663	766	709	816	756	866	802	916	848	966	894	0.3148	
517	479	567	525	617	571	667	618	717	664	767	710	817	756	867	803	917	849	967	895	0.3333	
518	480	568	526	618	572	668	619	718	665	768	711	818	757	868	804	918	850	968	896	0.3519	
519	481	569	527	619	573	669	619	719	666	769	712	819	758	869	805	919	851	969	897	0.3704	
520	481	570	528	620	574	670	620	720	667	770	713	820	759	870	806	920	852	970	898	0.3889	
521	482	571	529	621	575	671	621	721	668	771	714	821	760	871	806	921	853	971	899	0.4074	
522	483	572	530	622	576	672	622	722	669	772	715	822	761	872	807	922	854	972	900	0.4259	
523	484	573	531	623	577	673	623	723	669	773	716	823	762	873	808	923	855	973	901	0.4445	

SUM OF END AREAS

524	485	574	531	624	724	670	774	717	824	763	874	809	924	856	974	902	25	0.4630
525	486	575	532	625	725	671	775	718	825	764	875	810	925	856	975	903	26	0.4815
526	487	576	533	626	726	672	776	719	826	765	876	811	926	857	976	904	27	0.5000
527	488	577	534	627	727	673	777	719	827	766	877	812	927	858	977	905	28	0.5185
528	489	578	535	628	728	674	778	720	828	767	878	813	928	859	978	906	29	0.5370
529	490	579	536	629	729	675	779	721	829	768	879	814	929	860	979	906	30	0.5556
530	491	580	537	630	730	676	780	722	830	769	880	815	930	861	980	907	31	0.5741
531	492	581	538	631	731	677	781	723	831	769	881	816	931	862	981	908	32	0.5926
532	493	582	539	632	732	678	782	724	832	770	882	817	932	863	982	909	33	0.6111
533	494	583	540	633	733	679	783	725	833	771	883	818	933	864	983	910	34	0.6296
534	494	584	541	634	734	680	784	726	834	772	884	819	934	865	984	911	35	0.6482
535	495	585	542	635	735	681	785	727	835	773	885	819	935	866	985	912	36	0.6667
536	496	586	543	636	736	681	786	728	836	774	886	820	936	867	986	913	37	0.6852
537	497	587	544	637	737	682	787	729	837	775	887	821	937	868	987	914	38	0.7037
538	498	588	544	638	738	683	788	730	838	776	888	822	938	869	988	915	39	0.7222
539	499	589	545	639	739	684	789	731	839	777	889	823	939	869	989	916	40	0.7408
540	500	590	546	640	740	685	790	731	840	778	890	824	940	870	990	917	41	0.7593
541	501	591	547	641	741	686	791	732	841	779	891	825	941	871	991	918	42	0.7778
542	502	592	548	642	742	687	792	733	842	780	892	826	942	872	992	919	43	0.7963
543	503	593	549	643	743	688	793	734	843	781	893	827	943	873	993	919	44	0.8148
544	504	594	550	644	744	689	794	735	844	781	894	828	944	874	994	920	45	0.8333
545	505	595	551	645	745	690	795	736	845	782	895	829	945	875	995	921	46	0.8519
546	506	596	552	646	746	691	796	737	846	783	896	830	946	876	996	922	47	0.8704
547	506	597	553	647	747	692	797	738	847	784	897	831	947	877	997	923	48	0.8889
548	507	598	554	648	748	693	798	739	848	785	898	831	948	878	998	924	49	0.9074
549	508	599	555	649	749	694	799	740	849	786	899	832	949	879	999	925	50	0.9259
1000 = 926	2000 = 1852	3000 = 2778	4000 = 3704	5000 = 4630	6000 = 5556	7000 = 6481	8000 = 7407											

\* Based on average end area formula. Not as accurate as prismoidal, but as accurate as usual field measurements warrant. Specified for payment quantities by most state highway departments.  
For examples illustrating use of table see p. 235.

TABLE 18. PRISMOIDAL CORRECTIONS FOR L = 100' STATIONS \*

$c_1 - c_2 =$	1	2	3	4	5	6	7	8	9
$D_1 - D_2$									
0.1	0.03	0.06	0.09	0.12	0.15	0.19	0.22	0.25	0.28
0.2	0.06	0.12	0.19	0.25	0.31	0.37	0.43	0.49	0.56
0.3	0.09	0.19	0.28	0.37	0.46	0.56	0.65	0.74	0.83
0.4	0.12	0.25	0.37	0.49	0.62	0.74	0.86	0.99	1.11
0.5	0.15	0.31	0.46	0.62	0.77	0.93	1.08	1.23	1.39
0.6	0.19	0.37	0.56	0.74	0.93	1.11	1.30	1.48	1.67
0.7	0.22	0.43	0.65	0.86	1.08	1.30	1.51	1.73	1.94
0.8	0.25	0.49	0.74	0.99	1.23	1.48	1.73	1.98	2.22
0.9	0.28	0.56	0.83	1.11	1.39	1.67	1.94	2.22	2.50
1.0	0.31	0.62	0.93	1.23	1.54	1.85	2.16	2.47	2.78
1.1	0.34	0.68	1.02	1.36	1.70	2.04	2.38	2.72	3.06
1.2	0.37	0.74	1.11	1.48	1.85	2.22	2.59	2.96	3.33
1.3	0.40	0.80	1.20	1.60	2.01	2.41	2.81	3.21	3.61
1.4	0.43	0.86	1.30	1.73	2.16	2.59	3.02	3.46	3.89
1.5	0.46	0.93	1.39	1.85	2.31	2.78	3.24	3.70	4.17
1.6	0.49	0.99	1.48	1.98	2.47	2.96	3.46	3.95	4.44
1.7	0.52	1.05	1.57	2.10	2.62	3.15	3.67	4.20	4.72
1.8	0.56	1.11	1.67	2.22	2.78	3.33	3.89	4.44	5.00
1.9	0.59	1.17	1.76	2.35	2.93	3.52	4.10	4.69	5.28
2.0	0.62	1.23	1.85	2.47	3.09	3.70	4.32	4.94	5.56
2.1	0.65	1.30	1.94	2.59	3.24	3.89	4.54	5.19	5.83
2.2	0.68	1.36	2.04	2.72	3.40	4.07	4.75	5.43	6.11
2.3	0.71	1.42	2.13	2.84	3.55	4.26	4.97	5.68	6.39
2.4	0.74	1.48	2.22	2.96	3.70	4.44	5.19	5.93	6.67
2.5	0.77	1.54	2.31	3.09	3.86	4.63	5.40	6.17	6.94
2.6	0.80	1.60	2.41	3.21	4.01	4.81	5.62	6.42	7.22
2.7	0.83	1.67	2.50	3.33	4.17	5.00	5.83	6.67	7.50
2.8	0.86	1.73	2.59	3.46	4.32	5.19	6.05	6.91	7.78
2.9	0.90	1.79	2.69	3.58	4.48	5.37	6.27	7.16	8.06
3.0	0.93	1.85	2.78	3.70	4.63	5.56	6.48	7.41	8.33
3.1	0.96	1.91	2.87	3.83	4.78	5.74	6.70	7.65	8.61
3.2	0.99	1.98	2.96	3.95	4.94	5.93	6.91	7.90	8.89
3.3	1.02	2.04	3.06	4.07	5.09	6.11	7.13	8.15	9.17
3.4	1.05	2.10	3.15	4.20	5.25	6.30	7.35	8.40	9.44
3.5	1.08	2.16	3.24	4.32	5.40	6.48	7.56	8.64	9.72
3.6	1.11	2.22	3.33	4.44	5.56	6.67	7.78	8.89	10.00
3.7	1.14	2.28	3.43	4.57	5.71	6.85	7.99	9.14	10.28
3.8	1.17	2.35	3.52	4.69	5.86	7.04	8.21	9.38	10.56
3.9	1.20	2.41	3.61	4.81	6.02	7.22	8.43	9.63	10.83
4.0	1.23	2.47	3.70	4.94	6.17	7.41	8.64	9.88	11.11
4.1	1.27	2.53	3.80	5.06	6.33	7.59	8.86	10.12	11.39
4.2	1.30	2.59	3.89	5.19	6.48	7.78	9.07	10.37	11.67
4.3	1.33	2.65	3.98	5.31	6.64	7.96	9.29	10.62	11.94
4.4	1.36	2.72	4.07	5.43	6.79	8.15	9.51	10.86	12.22
4.5	1.39	2.78	4.17	5.56	6.94	8.33	9.72	11.11	12.50
4.6	1.42	2.84	4.26	5.68	7.10	8.52	9.94	11.36	12.78
4.7	1.45	2.90	4.35	5.80	7.25	8.70	10.15	11.60	13.06
4.8	1.48	2.96	4.44	5.93	7.41	8.89	10.37	11.85	13.33
4.9	1.51	3.02	4.54	6.05	7.56	9.07	10.50	12.10	13.61
5.0	1.54	3.09	4.63	6.17	7.72	9.26	10.80	12.35	13.89
$c_1 - c_2 =$	1	2	3	4	5	6	7	8	9

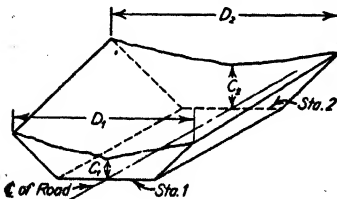

EXAMPLE. Given.  $c_1 = 4'$ ,  $D_1 = 130'$ ,  $c_2 = 8'$ ,  $D_2 = 138'$ .  
 Required. Prismoidal correction value.

Solution.  $c_1 - c_2 = 4$ ;  $D_1 - D_2 = 8$ . Enter table at 8.0; read correction = 9.88 cu. yd.  $(c_2 - c_1)(D_2 - D_1) = (8 - 4)(138 - 130) = +$ . Subtract correction from volume by average end area method. See p. 234.

TABLE 18. PRISMOIDAL CORRECTIONS FOR L = 100' STATIONS,\*  
Continued

$c_1 - c_2 =$	1	2	3	4	5	6	7	8	9
$D_1 - D_2$									
5.1	1.57	3.15	4.72	6.30	7.87	9.44	11.02	12.59	14.17
5.2	1.60	3.21	4.81	6.42	8.02	9.63	11.23	12.84	14.44
5.3	1.64	3.27	4.91	6.54	8.18	9.81	11.45	13.09	14.72
5.4	1.67	3.33	5.00	6.67	8.33	10.00	11.67	13.33	15.00
5.5	1.70	3.40	5.09	6.79	8.49	10.19	11.88	13.58	15.28
5.6	1.73	3.46	5.19	6.91	8.64	10.37	12.10	13.83	15.56
5.7	1.76	3.52	5.28	7.04	8.80	10.56	12.31	14.07	15.83
5.8	1.79	3.58	5.37	7.16	8.95	10.74	12.53	14.32	16.11
5.9	1.82	3.64	5.46	7.28	9.10	10.93	12.75	14.57	16.39
6.0	1.85	3.70	5.56	7.41	9.26	11.11	12.96	14.81	16.67
6.1	1.88	3.77	5.65	7.53	9.41	11.30	13.18	15.06	16.94
6.2	1.91	3.83	5.74	7.65	9.57	11.48	13.40	15.31	17.22
6.3	1.94	3.89	5.83	7.78	9.72	11.67	13.61	15.56	17.50
6.4	1.98	3.95	5.93	7.90	9.88	11.85	13.83	15.80	17.78
6.5	2.01	4.01	6.02	8.02	10.03	12.04	14.04	16.05	18.06
6.6	2.04	4.07	6.11	8.15	10.19	12.22	14.26	16.30	18.33
6.7	2.07	4.14	6.20	8.27	10.34	12.41	14.48	16.54	18.61
6.8	2.10	4.20	6.30	8.40	10.49	12.59	14.69	16.79	18.89
6.9	2.13	4.26	6.39	8.52	10.65	12.78	14.91	17.04	19.17
7.0	2.16	4.32	6.48	8.64	10.80	12.96	15.12	17.28	19.44
7.1	2.19	4.38	6.57	8.77	10.96	13.15	15.34	17.53	19.72
7.2	2.22	4.44	6.67	8.89	11.11	13.33	15.56	17.78	20.00
7.3	2.25	4.51	6.76	9.01	11.27	13.52	15.77	18.02	20.28
7.4	2.28	4.57	6.85	9.14	11.42	13.70	15.99	18.27	20.56
7.5	2.31	4.63	6.94	9.26	11.57	13.89	16.20	18.52	20.83
7.6	2.35	4.69	7.04	9.38	11.73	14.07	16.42	18.77	21.11
7.7	2.38	4.75	7.13	9.51	11.88	14.26	16.64	19.01	21.39
7.8	2.41	4.81	7.22	9.63	12.04	14.44	16.85	19.26	21.67
7.9	2.44	4.88	7.31	9.75	12.19	14.63	17.07	19.51	21.94
8.0	2.47	4.94	7.41	9.88	12.35	14.81	17.28	19.75	22.22
8.1	2.50	5.00	7.50	10.00	12.50	15.00	17.50	20.00	22.50
8.2	2.53	5.06	7.59	10.12	12.65	15.19	17.72	20.25	22.78
8.3	2.56	5.12	7.69	10.25	12.81	15.37	17.93	20.49	23.06
8.4	2.59	5.19	7.78	10.37	12.96	15.56	18.15	20.74	23.33
8.5	2.62	5.25	7.87	10.49	13.12	15.74	18.36	20.99	23.61
8.6	2.65	5.31	7.96	10.62	13.27	15.93	18.58	21.23	23.89
8.7	2.69	5.37	8.06	10.74	13.43	16.11	18.80	21.48	24.17
8.8	2.72	5.43	8.15	10.86	13.58	16.30	19.01	21.73	24.44
8.9	2.75	5.49	8.24	10.99	13.73	16.48	19.23	21.97	24.72
9.0	2.78	5.56	8.33	11.11	13.89	16.67	19.44	22.22	25.00
9.1	2.81	5.62	8.43	11.23	14.04	16.85	19.66	22.47	25.28
9.2	2.84	5.68	8.52	11.36	14.20	17.04	19.88	22.72	25.56
9.3	2.87	5.74	8.61	11.48	14.35	17.22	20.09	22.96	25.83
9.4	2.90	5.80	8.70	11.60	14.51	17.41	20.31	23.21	26.11
9.5	2.93	5.86	8.80	11.73	14.66	17.59	20.52	23.46	26.39
9.6	2.96	5.93	8.89	11.85	14.81	17.78	20.74	23.70	26.67
9.7	2.99	5.99	8.98	11.98	14.97	17.96	20.96	23.95	26.94
9.8	3.02	6.05	9.07	12.10	15.12	18.15	21.17	24.20	27.22
9.9	3.06	6.11	9.17	12.22	15.28	18.33	21.39	24.44	27.50
10.0	3.09	6.17	9.26	12.35	15.43	18.52	21.60	24.69	27.78
$c_1 - c_2 =$	1	2	3	4	5	6	7	8	9

$c_1$ ,  $c_2$ ,  $D_1$ , and  $D_2$  are shown for a three-level section. Volume by average end area  $\pm$  prismatic correction = volume by prismatic formula.

When  $(c_2 - c_1)(D_2 - D_1)$  is +, subtract correction.

When  $(c_2 - c_1)(D_2 - D_1)$  is -, add correction.

Irregular sections are generally treated the same as three-level sections.

\*From *American Civil Engineers Handbook* by Merriman and Wiggin.

# LEVELING

## SAMPLE NOTES

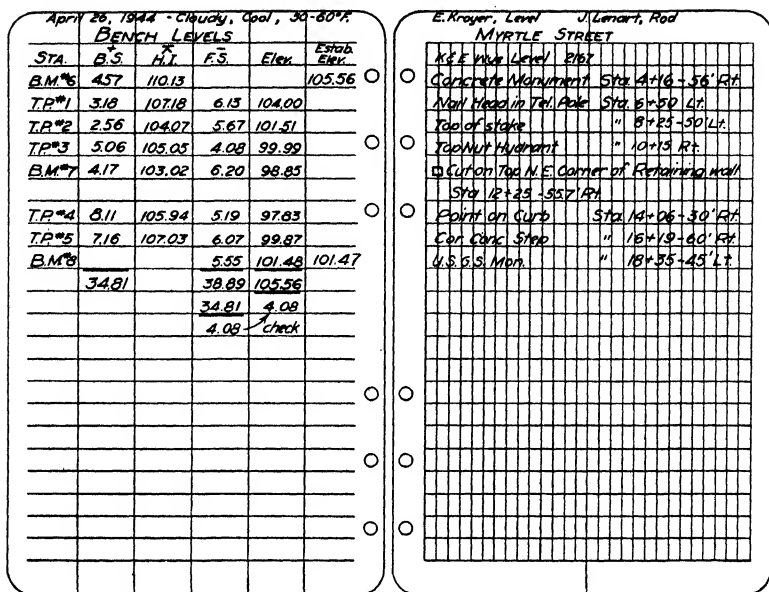

FIG. 20.

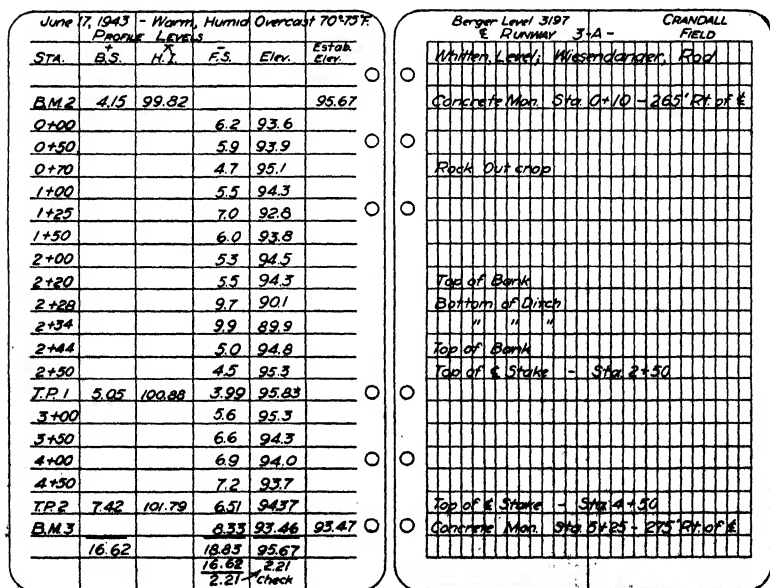
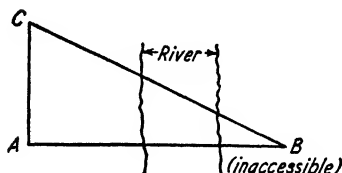

FIG. 21.

TRANSIT PROBLEMS

1. Determination of Distance to Inaccessible Point



**Required.**  $AB$ .

**Procedure.** Set transit at  $A$ , sight on  $B$ . Turn  $90^\circ$  and set  $C$  at a point at least equal to  $\frac{1}{2}AB$ . Measure length  $AC$ . Set up at  $C$  and measure angle  $ACB$ .  $AB = AC \times \text{tangent } ACB$ .

2. Angles by Repetition \*

**Required.** A more accurate determination of an angle than possible by a single measurement.

**Procedure.** (1) Set the transit very carefully over the point. (2) Set the  $A$  vernier at zero, read the  $B$  vernier, and record the readings. (3) With the telescope in its normal position, measure one of the angles in a clockwise direction, and record both vernier readings to the smallest reading of the vernier. (4) Leaving the upper motion clamped, again set on the first point and again measure the angle in a clockwise direction (thus doubling the angle). (5) Continue until six repetitions have been secured. Record both vernier readings and the total angle turned. (6) In a like manner, setting the  $B$  vernier at zero, measure the complement of the angle in a counterclockwise direction with the bubble down, but read the horizontal circle as though the angle itself had been measured clockwise. (7) Go through the same process for all other angles about the point. (8) Compute the value of each of the angles for each direction turned, and compare with the single measurement. (9) Find the mean of these sets of single angles. For a transit reading to single minutes the total error should not exceed  $10''\sqrt{n}$ , in which  $n$  is the number of observations. (10) Adjust the angles so that their sum shall equal  $360^\circ$  by distributing the error equally among the mean values.

**Hints and Precautions.** (1) Level the transit very carefully before each repetition, but do not disturb the leveling screws while a measurement is being made. (2) The mean of each set of single angles should furnish a value free from instrumental errors. The station adjustment is an attempt to distribute the accidental errors so that the condition that there are  $360^\circ$  about a point shall be fulfilled. (3) Do not become

\* Adapted from Davis, *Manual of Surveying*, McGraw-Hill.

confused when calculating the total angle turned. Observe how the horizontal limb is graduated, and do not omit  $360^\circ$ . (4) The instrument should be handled very carefully. When turning on the lower motion the hands should be in contact with the lower plate (not the alidade), and when making an exact setting on a point the last movement of the tangent screw should be clockwise or against the opposing spring. (5) After each repetition the instrument should be turned on its lower motion in a direction opposite to that of the measurement. (6) The single measurement is taken as a check on the number of repetitions. It should agree closely with the mean value.

**Practical Applications.** This method is used in triangulation work to measure any angle accurately. The number of sets of readings and the number of repetitions in each set observed depend upon the desired accuracy.

### 3. Laying off Angles by Repetition \*

**Required.** To lay off a given horizontal angle more accurately than by a single setting of the vernier.

**Procedure.** (1) Set the transit carefully over the point and lay off the angle. (2) Set a stake on the line of sight, preferably at least 500 ft. from the instrument, and carefully set a tack. (3) By repetition measure the angle laid off, as in the previous problem, making six repetitions in each direction. (4) Find the angular discrepancy between the angle laid off and the required angle. Move the tack perpendicular to the line of sight, a distance equal to the sine of the angular discrepancy times the measured distance between the stakes. (5) Set the tack accordingly.

**Practical Applications.** This method is of use in laying out large buildings, valuable city lots or right of ways, important highway work such as viaducts and bridges, and airport runway center lines. With a transit vernier reading to 1 minute, an error of 30 in. in a single reading might easily occur; in 300 ft. this would amount to approximately  $\frac{1}{2}$  in.

### 4. Area by Double Meridian Distance \*

**Required.** Area of a closed traverse.

**Rules.**

Latitude = distance times cosine bearing angle.

Departure = distance times sine bearing angle.

Latitudes and departures are positive or negative according as they are north and east or south and west.

In any closed traverse the algebraic sum of the latitudes (or departures) must equal zero.

Compass rule for balancing. The correction to be applied to the lati-

\* Adapted from Davis, *Manual of Surveying*, McGraw-Hill.

tude (or departure) of any course is to the total error in latitude (or departure) as the length of the course is to the perimeter of the field.

**Transit rule for balancing.** The correction to be applied to the latitude (or departure) of any course is to the total error in latitude (or departure) as the latitude (or departure) of that course is to the arithmetical sum of all the latitudes (or departures).

**Rules for double meridian distances.** (1) The D.M.D. of the first course equals the departure of that course.

(2) The D.M.D. of any other course equals the D.M.D. of the preceding course plus the departure of the preceding course plus the departure of the course itself.

(3) The D.M.D. of the last course is numerically equal to the departure of that course, but with opposite sign.

**Procedure.** (1) Transcribe necessary data from the field book into a form similar to that shown below. Check the copy.

(2) Calculate the latitude and departure of each course, using logarithms as shown in sample computations or more quickly and accurately with natural functions and a calculating machine if one is available. Check results with the slide rule.

(3) Determine the total error in latitude and in departure, and compute the error of closure.

(4) Determine the latitude and departure corrections by one of the preceding rules for balancing.

(5) Apply these corrections, and check by taking the algebraic sum of the corrected latitudes and the algebraic sum of the corrected departures. Each of these sums should equal zero.

(6) From the corrected departures compute the D.M.D.'s, applying the preceding rules and starting from the most westerly point in the survey. If the last D.M.D. is not numerically equal to the last corrected departure, it will indicate that a mistake in addition has been made.

(7) Compute double areas by the preceding rule paying special attention to signs. Check computations.

(8) Sum up the double areas, divide by 2, and transform into acres.

**Hints and Precautions.** (1) Use tables of logarithms or natural functions with number of places consistent with the precision of the field measurements. If the bearings have been determined with the surveyor's compass, four places will be sufficient; if angles have been taken to the nearest minute (in error less than 30 seconds) with the transit, five-place tables should be used.

(2) Checks should be applied after each of the steps in the computations. An absolute check on the work can, of course, be had only by recomputation, by methods that will give as many significant figures in the final result as the original computations gave. However, the slide rule will furnish an approximate check, which is very desirable.



(3) If, after having calculated the latitudes and departures and after having checked them against large errors, the error of closure is found to be larger than that allowable, the computer may frequently locate the mistake, whether it be in computations or field work, through the relation of total error in latitudes and total error in departures. Thus, if the mistake is in the length of one line and there are no other large errors, the ratio of the total error in departures to the total error in latitudes will approximately express the tangent of the bearing angle of that line, or if a mistake has been made in the latitude of a line the departures may nearly close. The computer should, therefore, conduct a critical examination of results and should then recompute those values that seem most likely to contain the mistake. If the mistake is not brought to light when all latitudes and departures have been rechecked, then, and only then, may he be warranted in concluding that the mistake occurred in the field.

(4) The compass rule or transit rule will be used for balancing latitudes and departures according as the error is assumed to be as much in angles as in distances or as the error is assumed to be mostly due to erroneous lengths.

(5) When the error of closure is small, the latitudes and departures may usually be balanced by inspection without computing the corrections by either of the preceding rules. When the computer knows the conditions surrounding the field work, he may often distribute the error according to his own judgment rather than by any fixed rule.

(6) Often neither calculated nor magnetic bearings of lines are shown in the transit notes. If deflection or interior angles were taken, it will be convenient to assume one of the lines in the traverse as the meridian and calculate the bearings of other lines accordingly. If magnetic bearings are recorded in the field notes, they should not be confused with calculated bearings and used as the basis of computations, for their precision will not warrant such use.

(7) Corrections for erroneous length of chain or tape should not be overlooked. Constant errors of this sort will have no effect on the error of closure.

(8) By starting with the most westerly point in the survey all the D.M.D.'s become positive; it is not necessary for the solution of the problem that this point be chosen, but it is customary.

**Practical Applications.** The double meridian distance method of calculating the area within a closed traverse is universally followed in preference to subdividing into triangles. It is generally agreed that it takes less time, is more systematic, and offers more easy checks; through the use of latitudes and departures, the error of closure is readily determined.

Some surveyors favor the method of double parallel distances, which is the same in principle as the preceding method, the only difference being that in double parallel distances (D.P.D.'s) the bases of trapezoids are

Line	Cal. Bear.	Dist. 66' Ch.	Latitudes		Departures		Corrected		D.M.Ds.	Double Areas	
			N	S	E	W	Lats.	Depts.		+	-
A-B	S 80°29'W	34.464		5.694		33.991	- 5.693	- 33.990	61.812		351.89
B-C	S 33°04' W	25.493		21.384		13.911	- 21.381	- 13.911	13.911		297.15
C-D	S 33°46' E	33.934		28.205	18.867		- 28.201	+ 18.867	18.867		532.06
D-E	N 87°59½' E	28.625	1.013		28.607		+ 1.013	+ 28.608		67.21	
E-A	N 0°27' E	54.235	54.234		0.426		+ 54.242	+ 0.426	95.376	5172.51	
		176.775	55.247	55.263	47.900	47.902	ΣL=0	ΣD=0		5240.72	1181.10
				55.247		47.900				1181.10	
				.016		.002				2 4058.62	
<p>E. of C. = <math>\frac{016}{176.751} = \frac{1}{11,000}</math>      <math>E = \sqrt{.016^2 + .002^2} = 0.016</math> Chains.</p>											
Line	A-B	B-C	C-D	D-E	E-A						
Lat.	5.694	21.384	28.205	1.013	54.234						
Log. Lat.	0.75542	1.32968	1.45032	0.00584	1.73427						
Log. Cos.	9.21805	9.92326	9.91969	8.54899	9.99999						
Log. Dist.	1.53737	1.40642	1.53063	1.45674	1.73428						
Log. Sin.	9.99399	9.73689	9.74509	9.99973	7.89535						
Log. Dep.	1.53136	1.14331	2.27572	1.45847	9.62964						
Dep.	33.991	13.911	18.867	28.607	0.426						
Log. Cor. Lat.	0.75534	1.32962	1.45026	0.00584	1.73434						
Log. D.M.D.	1.79107	1.14336	1.27570	1.82179	1.97944						
Log. D.A.	2.54641	2.47298	2.72596	1.82763	3.71378						
Double Area	351.89	297.15	532.06	67.21	5173.51						

Note:  
Survey Balanced  
by Transit Rule.

FIG. 22.

along a line perpendicular to the meridian, whereas in double meridian distances they lie on the meridian itself. Thus, the rules for finding D.M.D.'s may be changed to rules for D.P.D.'s by substituting the word "latitude" for "departure"; and the rule for finding double areas will then be as follows: The double area of any trapezoid equals the product of its D.P.D. and its corrected departure.

5. Omitted Side \*

**Required.** Length and bearing of one side of a traverse, this side not accessible in field. (It is assumed that errors in measured sides are negligible; all errors are thrown into computed side.)

**Procedure.** (1) Calculate the latitudes and departures of the known lines as in the previous problem, and find their totals. (2) On the preceding assumption, and since the algebraic sum of latitudes and of departures for any closed traverse is zero, it follows that the latitude and departure of the unknown line are numerically equal to the sums of corresponding quantities for the known lines, but with opposite sign. Therefore, determine the bearing and length of the unknown line by the equations:

$$\text{Tan bearing angle} = \frac{\text{departure of line}}{\text{latitude of line}}$$

and

\* Adapted from Davis, *Manual of Surveying*, McGraw-Hill.

$$\begin{aligned} \text{Length of line} &= \sqrt{\text{latitude}^2 + \text{departure}^2} \\ &= \frac{\text{latitude of line}}{\cos \text{bearing angle}} = \frac{\text{departure of line}}{\sin \text{bearing angle}} \end{aligned}$$

**Precaution.** Plot known sides, and graphically check omitted side and bearing.

### 6. Prolongation of a Line by Double Sighting with Transit \* (Double Centering)

**Required.** To produce a straight line with precision.

**Procedure.** (1) Set the instrument carefully over the forward point on the line with the telescope normal and backsight on line. Use the lower horizontal motion, the upper motion being clamped. (2) Plunge the telescope, and set a stake on the line in advance. Mark a point on the stake exactly on line. (3) Take a second backsight on line in the same manner as before, with the telescope inverted. Plunge the telescope again, and mark a second point on the advance stake. (4) If this point is not coincident with the first point set, a point midway between them is on the line. (5) Set the transit over this point, and advance by the same process, backsighting upon the next point in the rear. Continue in this way for the desired distance.

**Hints and Precautions.** (1) Be sure that one backsight from each station is taken with the *telescope inverted* and one with the *telescope direct*. (2) Tacks should be set in all stakes, and after being set should be checked. A finely divided scale should be used for bisecting the distances. (3) Whenever an opportunity arises, take backsights as far back on a line as possible to check the line.

**Practical Applications.** The method of double sighting is used when it is desired to set a point in advance accurately on line. The process of double sighting eliminates instrumental errors. It is used in prolonging lines of a considerable length or setting points accurately ahead on line. Frequently a line prolonged by simply plunging the telescope with a transit supposed to be in perfect adjustment has later been found to be not a straight line but a curve of large radius. The same method should be used when setting transit points ahead on a curve.

### 7. Establishing a Line by Balancing-in with Transit (Bucking-in)

**Required.** To establish an intermediate transit point on a line when the two ends of the line are not intervisible.

**Procedure.** (1) Set up the transit where the intermediate point is required, and as near as can be estimated, on the line. (2) Backsight with telescope normal on the point marking one end of the line, and plunge

\* Adapted from Davis, *Manual of Surveying*, McGraw-Hill.

the telescope. (3) Move the transit a proportionate amount of the distance by which the line of sight fails to strike the point at the opposite end of the line. (4) Repeat the procedure until the line of sight is coincident with the line. (5) Establish the point by lowering the plumb bob of the transit. (6) Repeat the process with the telescope inverted as in double centering. If the instrument is not in adjustment a second point will be found; the correct point is set midway between the two.

**Hints and Precautions.** The final movement of the transit can usually be made with the shifting head. Until near the correct point, it is unnecessary to level the transit carefully. Additional points on the line can be set by direct sighting.

### 8. Layout of Circular Curve

**Required.** To establish the P.C. and P.T. of a simple curve and set points at intervals along the curve.

**Procedure.** (1) Lay off both tangents from the P.I., thus locating the P.C. and P.T. (2) Set up the transit over the P.C.; set vernier at zero and foresight on P.I. Unclamp the upper motion and sight at the P.T. if visible; the deflection angle of the long chord should equal  $\frac{1}{2}$  the external angle  $\Delta$ . (3) From the previously computed list of deflections, lay out the points on the curve using the proper deflection angle and subchord or full chord as required.

**Hints and Precautions.** (1) If the back tangent has been stationed the P.C. may be set from the nearest station. (2) When the survey is to be carried ahead the transit may be set up over the P.T. and the curve laid out from it, thus saving a set-up. (3) When setting a transit point or an accurate point on the curve (P.O.C.), the backsight should be checked and the deflection turned with the telescope plunged in both the inverted and direct positions, the point being set as in double centering for a straight line.

**Set-up on Curve.** When all the stations of a curve are not visible from either the P.C. or P.T., a transit point must be set at some point on the curve (P.O.C.) and the transit moved up to it. (1) Locate the P.O.C. (2) Set up over the P.O.C. backsight on the P.C. with a zero reading on the vernier. (3) Plunge the telescope, and turn the telescope inward until the vernier reading (deflection) for the P.O.C. is reached. The line of sight will then be tangent to the curve. (4) Lay off the deflections for the points to be set as computed in the original list.

**Note.** Any other station than the P.C. may be sighted provided the proper deflection is used. The following rules apply:

**Rule I.** When the transit is set on any point on a curve, an auxiliary tangent to the curve at that point may be found by sighting at any station on the curve with the deflection of the station sighted laid off on the proper side of zero and turning the upper motion until the vernier reading (deflection) for the point occupied is reached.

Rule II. When the transit is set on any point on a curve (including the P.C. or P.T.), any other point on the curve may be set by sighting at any point on the curve with the deflection for the point sighted laid off on the proper side of the vernier and turning the upper motion in the proper direction until the vernier reading (deflection) for the point to be set is reached.

## SAMPLE NOTES

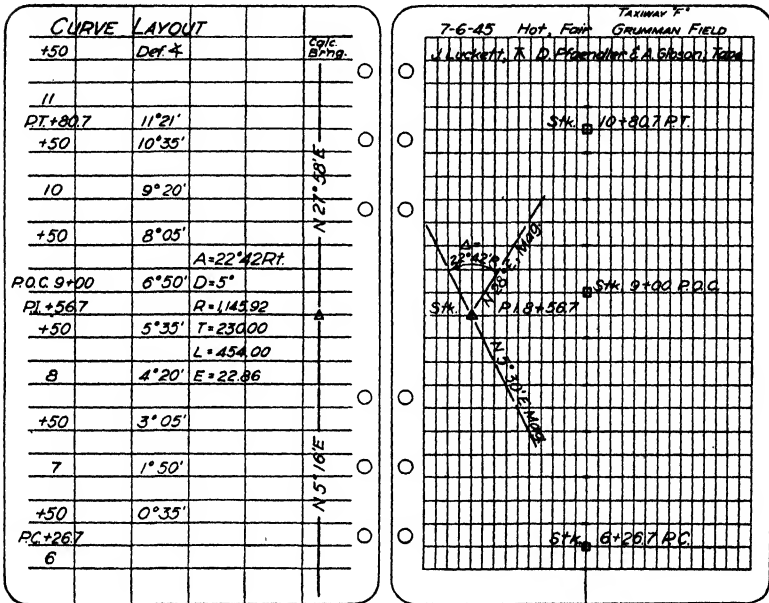

FIG. 23.

## ALLOWABLE ERRORS

## Leveling \*

*Rough leveling* for rapid reconnaissance or preliminary work; sights made up to 1000 ft.; rod readings to tenths; no attention paid to balancing backsights and foresights.

Suggested maximum error in feet =  $\pm 0.4\sqrt{\text{distance in miles}}$ .

Ordinary leveling as required for most engineering works; maximum sights 500 ft.; rod readings to hundredths; backsights and foresights roughly balance for both length of shots and uphill and downhill work; turning points on reasonably solid objects.

Suggested maximum error in feet =  $\pm 0.1\sqrt{\text{distance in miles}}$ .

\* Adapted from Urquhart, *Civil Engineering Handbook*, McGraw-Hill.

Accurate leveling, for principal bench marks; maximum sights 300 ft.; rod readings to thousandths; backsights and foresights paced and balanced; rod waved; bubble centered for each sight; turning points on very solid objects; level set very firmly.

Maximum error in feet =  $\pm 0.05\sqrt{\text{distance in miles}}$ .

This error is the same as allowed for third-order leveling, Corps of Engineers, U. S. Army.

### Distances

By stadia, 1:750 maximum allowable error.

By tape, 1:5000 maximum allowable error for ordinary work.

### Transit and Tape Traverses

Linear error of closure =  $\sqrt{(\text{sum of latitudes})^2 + (\text{sum of departures})^2}$ .

The precision of transit traverses is affected by both linear and angular errors of measurement. Many factors affect the precision, and it can be expressed only in very general terms. The following specifications give approximately the *maximum* linear and angular errors to be expected when the methods stated are followed. If the surveys are executed by well-trained men, with instruments in good adjustment, and under average field conditions, in general the error of closure should not exceed *half* the specified amount. The specifications apply to traverses of considerable length. It is assumed that a standardized tape is used.

Class 1. Precision sufficient for many preliminary surveys, for horizontal control of surveys plotted to intermediate scale, and for land surveys where the value of the land is low.

Transit angles read to the nearest minute. Sights taken on a range pole plumbed by eye. Distances measured with a 100-ft. steel tape. Pins or stakes set within 0.1 ft. of end of tape. Slopes under 3% disregarded. On slopes over 3%, distances either measured on the slope and corrections roughly applied, or measured with the tape held level and with an estimated standard pull.

Angular error of closure not to exceed  $1' 30''\sqrt{n}$ , in which  $n$  is the number of observations. Total linear error of closure not to exceed 1/1000.

Class 2. Precision sufficient for most land surveys and for location of highways, railroads, etc. By far the greater number of transit traverses fall in this class.

Transit angles read carefully to the nearest minute. Sights taken on a range pole carefully plumbed. Pins or stakes set within 0.05 ft. of end of tape. Temperature corrections applied to the linear measurements if the temperature of air differs more than 15° F. from standard. Slopes under 2% disregarded. On slopes over 2%, distances either measured on the slope and corrections roughly applied, or measured with the tape held level and with a carefully estimated standard pull.

Angular error of closure not to exceed  $1'\sqrt{n}$ . Total linear error of closure not to exceed 1/3000.

**Class 3.** Precision sufficient for much of the work of city surveying, for surveys of important boundaries, and for the control of extensive topographic surveys.

Transit angles read twice with the instrument plunged between observations. Sights taken on a plumb line or on a range pole carefully plumbed. Pins set within 0.05 ft. of end of tape. Temperature of air determined within  $10^{\circ}$  F., and corrections applied to the linear measurements. Slopes determined within 2%, and corrections applied. Tape held level, the pull kept within 5 lb. of standard, and corrections for sag applied.

Angular error of closure not to exceed  $30''\sqrt{n}$ . Total linear error of closure not to exceed 1/5000.

**Class 4.** Precision sufficient for accurate city surveying and for other especially important surveys.

Transit angles read twice with the instrument plunged between readings, each reading being taken as the mean of both *A* and *B* vernier readings. Verniers reading to  $30''$ . Instrument in excellent adjustment. Sights taken with special care. Pins set within 0.02 ft. of end of tape. Temperature of tape determined within  $5^{\circ}$  F., and corrections applied. Slopes determined within 1%, and corrections applied. Tape held level, the pull kept within 3 lb. of standard, and corrections for sag applied.

Angular error of closure not to exceed  $15''\sqrt{n}$ . Total linear error of closure not to exceed 1/10,000.\*

### DETERMINATION OF TRUE NORTH

#### OBSERVATION ON POLARIS

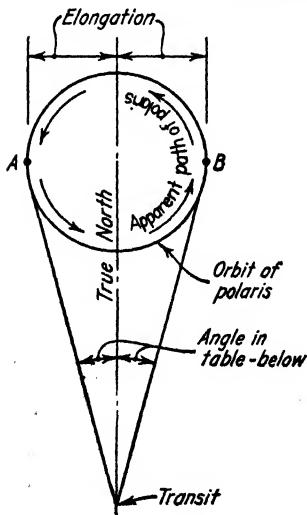

FIG. 24.

**Procedure.** Set up transit over a point. Observe Polaris at *A* or *B*, when the elongation remains constant—a 20-minute period during which Polaris appears to move vertically and actually varies not more than 0.1 minute from the elongation. Depress telescope and set a point ahead. Turn off the angle in Table 19 to give the true north.

\* L. C. Urquhart, *Civil Engineering Handbook*, McGraw-Hill.

TABLE 19. AZIMUTHS OF POLARIS AT ELONGATION, FOR THE BEGINNING OF YEARS 1940-1950 \*  
(Computed by the U. S. Naval Observatory)

Latitude °	1940		1941		1942		1943		1944		1945		1946		1947		1948		1949		1950		
	°	'	°	'	°	'	°	'	°	'	°	'	°	'	°	'	°	'	°	'	°	'	
25	1	7.6	1	7.3	1	7.0	1	6.7	1	6.4	1	6.1	1	5.7	1	5.3	1	5.0	1	4.6	1	4.2	
26		8.2		7.9		7.6		7.3		7.0		6.6		6.3		5.9		5.5		5.1		4.8	
27		8.8		8.5		8.2		7.9		7.5		7.2		6.8		6.5		6.1		5.7		5.3	
28		9.4		9.1		8.8		8.5		8.2		7.8		7.4		7.1		6.7		6.3		5.9	
29		10.1		9.8		9.5		9.2		8.8		8.5		8.1		7.7		7.3		6.9		6.5	
30		10.8		10.5		10.2		9.8		9.5		9.1		8.8		8.4		8.0		7.6		7.2	
31		11.5		11.2		10.9		10.6		10.2		9.9		9.5		9.1		8.7		8.3		7.9	
32		12.3		12.0		11.7		11.3		11.0		10.6		10.2		9.8		9.4		9.0		8.6	
33		13.1		12.8		12.5		12.1		11.8		11.4		11.0		10.6		10.2		9.8		9.4	
34		13.9		13.6		13.3		13.0		12.6		12.2		11.8		11.4		11.0		10.6		10.2	
35		14.8		14.5		14.2		13.8		13.5		13.1		12.7		12.3		11.9		11.5		11.1	
36		15.8		15.4		15.1		14.8		14.4		14.0		13.6		13.2		12.8		12.4		11.9	
37		16.8		16.4		16.1		15.7		15.4		15.0		14.6		14.1		13.7		13.3		12.9	
38		17.8		17.5		17.1		16.8		16.4		16.0		15.6		15.1		14.7		14.3		13.9	
39		18.9		18.5		18.2		17.8		17.4		17.0		16.6		16.2		15.8		15.3		14.9	
40		20.0		19.7		19.3		19.0		18.6		18.2		17.7		17.3		16.9		16.4		16.0	
41		21.2		20.9		20.5		20.1		19.7		19.3		18.9		18.5		18.0		17.6		17.1	
42		22.5		22.1		21.8		21.4		21.0		20.6		20.1		19.7		19.2		18.8		18.3	
43		23.8		23.5		23.1		22.7		22.3		21.9		21.4		21.0		20.5		20.0		19.6	
44		25.2		24.9		24.5		24.1		23.7		23.2		22.8		22.3		21.9		21.4		20.9	
45		26.7		26.3		25.9		25.5		25.1		24.7		24.2		23.7		23.3		22.8		22.3	
46		28.2		27.9		27.5		27.1		26.6		26.2		25.7		25.2		24.8		24.3		23.8	
47		29.9		29.5		29.1		28.7		28.3		27.8		27.3		26.8		26.3		25.8		25.3	
48		31.6		31.2		30.8		30.4		30.0		29.5		29.0		28.5		28.0		27.5		27.0	
49		33.4		33.0		32.6		32.2		31.7		31.3		30.8		30.3		29.8		29.2		28.7	
50		1	35.4	1	35.0	1	34.5	1	34.1	1	33.6	1	33.2	1	32.6	1	32.1	1	31.6	1	31.1	1	30.6

These data may be secured annually from the current *Nautical Ephemeris* or similar source.

\* From War Department, *Surveying Tables*.

Corrections for  
middle of  
months

For  
middle  
of—

Jan.  
Feb.  
Mar.  
Apr.  
May  
June  
July  
Aug.  
Sept.  
Oct.  
Nov.  
Dec.

Correc-  
tion

'  
-0.5  
-0.4  
-0.3  
-0.1  
+0.1  
+0.2  
+0.1  
-0.1  
-0.3  
-0.6  
-0.8



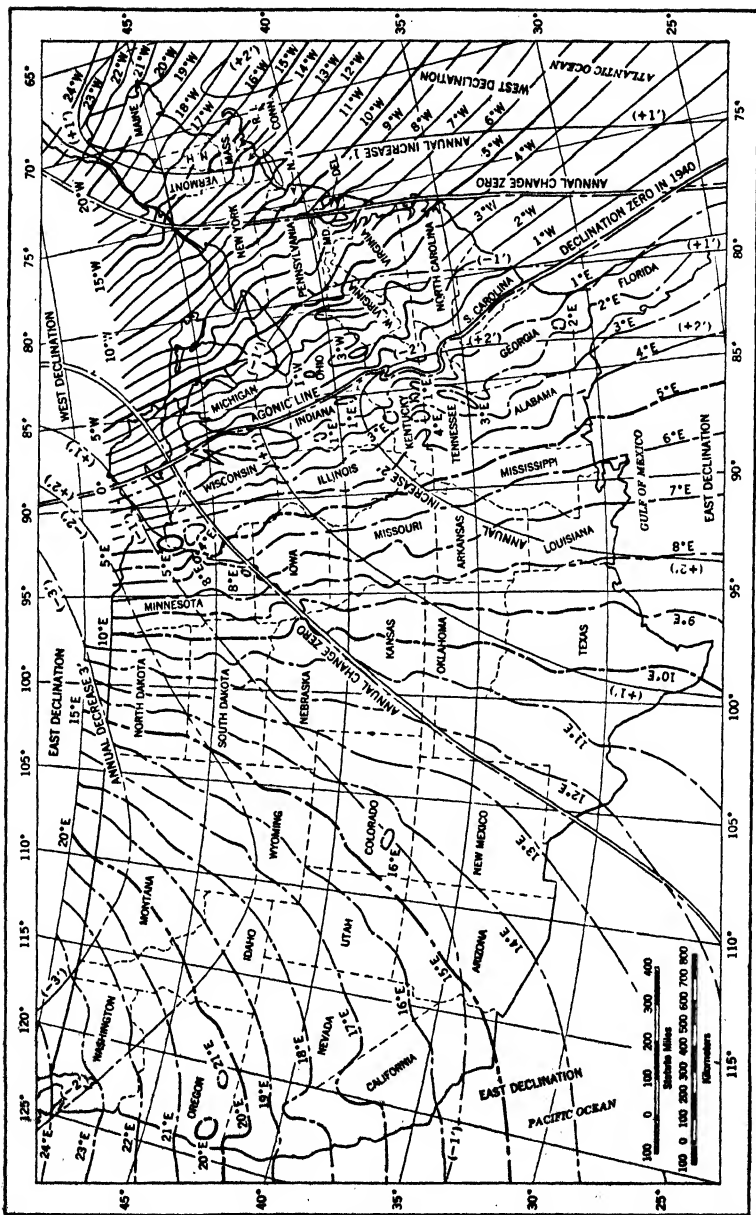

Fig. 25. Isogonic chart of the United States for 1940. From Tracy, Plane Surtceyting, by permission of the author and I. I. I. I. I.

There are two sets of lines on the isogonic chart, Fig. 25, which may be distinguished in two ways: (1) the isoporic lines are much smoother than the isogonic lines; (2) the isoporic lines are numbered in minutes and the isogonic lines in degrees.

The isogonic lines or lines of equal declination (also called "lines of equal variation of the compass") are drawn for January 1940. East of the agonic line, the lines are solid, signifying that the north end of the compass needle points west of true north; west of the agonic line they are dashed, and the compass points east of true north. The lines are drawn to show a smoothed distribution; in the more disturbed regions, the sinuosities of the lines must be regarded as an indication of irregularity rather than as a close representation of the declination.

Magnetic declination is subject to gradual change, the rate of which depends upon time and place. The annual rate of change prevailing from about 1934 to 1940 may be estimated from the isoporic lines. These lines are solid in regions where the prevailing declination was increasing, and dashed in regions in which the declination was decreasing. Note that, when an isoporic line crosses the agonic line, its sign changes.

### Vernier

Accurate readings on scales will fall somewhere between rather than on the subdivision marks on a scale. The vernier is a supplementary scale designed to aid in evaluating these fractional overages.

It is an adjacent scale against which slides the main scale as illustrated in the figure at the right. The zero of the vernier scale becomes the point from which the reading on the main scale is taken. The divisions of the vernier are a little smaller than those on the main scale. Thus 10 subdivisions on the vernier scale equal 9 subdivisions on the main scale.

The refinement is given by reading to the nearest subdivision on the main scale opposite the zero on the vernier and looking along the scale until the point is reached where the subdivisions of the vernier scale and the main scale appear coincident. For instance, in the two scales illustrated, if the major subdivisions on the main scales are tenths of a foot, the reading of the scale marked *E* would be 0.345 ft. The reading of the scale marked *F* would be 0.407 ft.

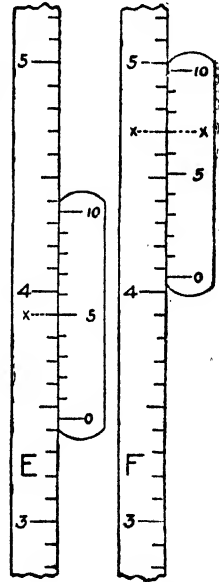

*From Tracy, Surveying: Theory and Practice, by permission of the author and John Wiley & Sons.*

# INSTRUMENTS AND THEIR ADJUSTMENTS \*

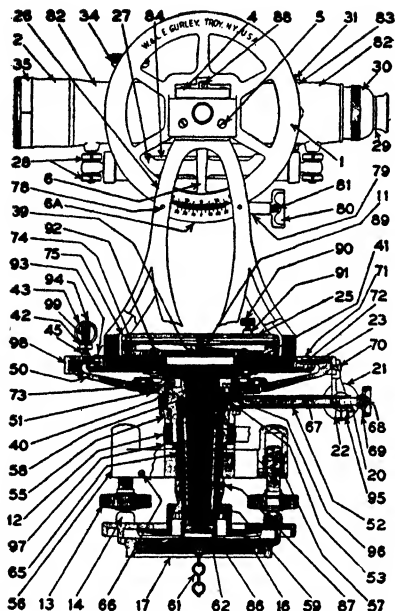

Cross section of Gurley transit.

## Parts of Gurley Precise Transits

1. Vertical circle guard.
2. Dust shield, protecting objective slide.
3. Detachable sunshade. (Not illus.)
4. Cap screws to standard.
5. Screws—guard to standard.
6. Vertical circle.
- 6A. Vertical circle vernier.
7. Side plate level.
9. North (or transverse) plate level.
11. Compass needle.
12. Lower (or leveling head) clamp.
13. Leveling screw.
14. Leveling screw cup.
15. Lower tangent screw. (Not illus.)
16. Shifting center.
17. Bottom plate.
18. Lower clamp screw. (Not illus.)
20. Upper (or limb) clamp screw.
21. Upper (or limb) tangent screw.
22. Upper (or plate) tangent hanger.
23. "A" vernier.
24. Needle lifter.
25. Compass glass cover in metal bezel ring.
26. One piece truss standard.
27. Telescope level.
28. Adjusting nuts for telescope level.
29. Eyepiece cap.
30. Knurled ring for eyepiece focusing.
31. Capstan screw for adjusting cross-wires.
32. Clamp screw for telescope axle.
33. Objective slide adjusting screw.
34. Objective focusing pinion.
35. Objective cap.
36. Side (or longitudinal) level vial.
39. Center pin.
40. Limb centering screws.
41. Screw—plate to spindle.
42. Capstan nut—north (or transverse) vial.
44. Spring guard to north vial.
45. Plate level post.
46. Top plate.
47. Screw—plate to standard.
49. Index pointer for magnetic declination.
50. Limb.
51. Socket.
52. Limb clamp.
53. Screw—clamp sleeve to socket.
54. Clamp sleeve.
55. Clamp collar.
56. Spider, or four-arm piece.
57. Leveling screw nut.
58. Spindle.
59. Half-ball.
61. Jack or plummet chain.
62. Bottom cap.
64. Washer—end of spindle.
65. Shell.
66. Keeper screw.
67. Limb clamp plunger.
68. Locking screw—head to stem of clamp screw.
69. Clamp screw head.
70. Screw—tangent hanger to plate.
71. Vernier glass.
72. Screw—vernier to plate.
73. Screw—limb to socket.
74. Needle circle.
75. Bezel ring.
78. Screw—v.c. vernier to standard.
79. Axis tangent screw stem.
80. Head, axis tangent screw.
81. Locking screw—head to stem of axis tangent screw.
82. Telescope.
83. Collet, for cross-wire adjusting.
84. Telescope level vial.
86. Nut—end of spindle.
87. Half-ball set screw.
88. Capstan adjusting screw in standard cap.
90. Needle lifter screw.
91. Needle lifter housing.
92. Screw—compass to plate.
93. Screw—cover ring to standard base.
94. Nut—top of plate level post.
95. Take-up screw to limb tangent.
96. Gib—leveling head clamp.
97. Spacer ring.
98. Cover ring.
99. Plate level adjusting spring.

\* From *Surveying Instrument Manual*, W. & L. E. Gurley, Troy, N. Y.

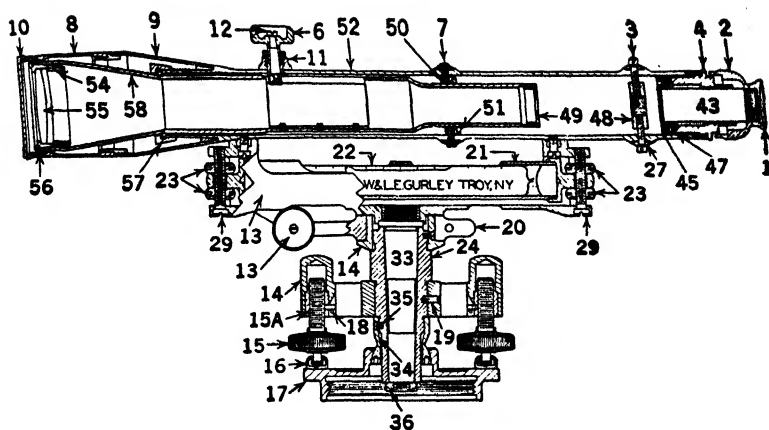

Cross section of Gurley dumpy level.

**Parts for Gurley Dumpy Levels**

- |   |  |
|---|--|
| 1. Eyepiece cap.                            | 22. Telescope level vial.                            |
| 2. Eyepiece focusing ring.                  | 23. Capstan adjusting nuts for telescope level vial. |
| 3. Capstan screw for adjusting cross wires. | 24. Shell or outer bearing.                          |
| 4. Eyepiece body.                           | 27. Collet for cross-wire adjusting screws.          |
| 6. Objective focusing pinion.               | 29. Post for adjusting telescope level.              |
| 7. Objective slide centering screw.         | 33. Spindle.   |
| 8. Dust shield.                             | 34. Half ball.                                       |
| 9. Main tube head.                          | 35. Screw for half ball.                             |
| 10. Objective cap.                          | 36. Nut, end of spindle.                             |
| 11. Objective pinion body.                  | 45. Eyepiece centering ring.                         |
| 12. Objective pinion screw.                 | 47. Eyepiece centering screw.                        |
| 13. Bar.                                    | 48. Cross-wire reticule.                             |
| 14. Leveling head.                          | 49. Diaphragm in slide.                              |
| 15. Leveling screw.                         | 50. Objective slide centering ring.                  |
| 15A. Leveling screw bushing.                | 51. Babbit, slide centering ring.                    |
| 16. Leveling screw cup.                     | 52. Main tube.                                       |
| 17. Bottom plate.                           | 54. Inner ring, objective setting.                   |
| 18. Leveling screw keeper screw.            | 55. Objective lens.                                  |
| 19. Shell set screw.                        | 56. Outer ring, objective setting.                   |
| 20. Leveling head clamp.                    | 57. Babbit, for objective end.                       |
| 21. Telescope level.                        | 58. Objective slide.                                 |

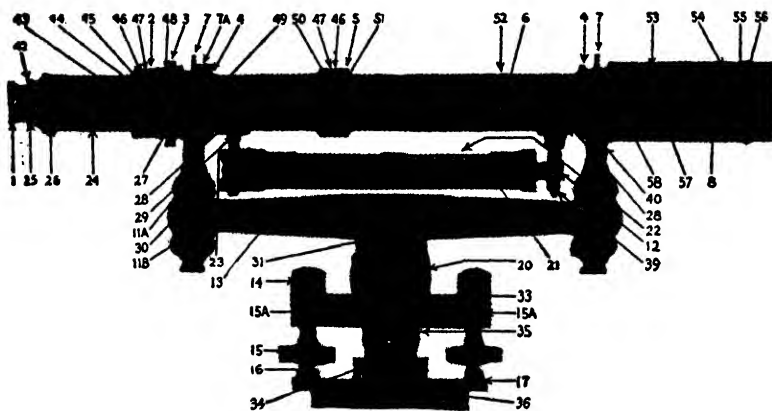

Quarter section of Gurley wye level.

## Parts for Gurley Wye Levels

- |   |   |
|---|---|
| 1. Eyepiece cap.  | 27. Collet, for cross-wire centering screws.    |
| 2. Cover ring, covering eyepiece centering screws.        | 28. Screws for telescope level hanger and post. |
| 3. Capstan screw, for adjusting cross wires.              | 29. Telescope level post.                       |
| 4. Wye rings.   | 30. Spline.                                     |
| 5. Cover ring, covering objective slide adjusting screws. | 31. Spindle head.                               |
| 6. Objective focusing pinion.                             | 33. Spindle.                                    |
| 7. Wye pin.   | 34. Half ball.                                  |
| 7A. Wye clip stop pin.                                    | 35. Screw for half ball.                        |
| 8. Dust shield.   | 39. Hanger for telescope level.                 |
| 9. Sunshade.*   | 40. Wye complete.                               |
| 11A. Wye capstan nuts (upper).                            | 42. Babbit ring, in sleeve for eyepiece.        |
| 11B. Wye capstan nuts (lower).                            | 43. Eyepiece.                                   |
| 12. Level lateral adjusting screw.                        | 44. Babbit, in eyepiece centering ring.         |
| 13. Wye bar.  | 45. Eyepiece centering ring.                    |
| 14. Leveling head.  | 46. Collet, for eyepiece centering screw.       |
| 15. Leveling screw.                                       | 47. Eyepiece centering screw.                   |
| 16. Leveling screw cup.                                   | 48. Cross-wire reticule.                        |
| 17. Bottom plate.   | 49. Diaphragm in slide.                         |
| 20. Leveling head clamp.                                  | 50. Slide centering ring.                       |
| 21. Telescope level complete.                             | 51. Babbit, slide centering ring.               |
| 22. Telescope level vial.                                 | 52. Main tube.                                  |
| 23. Vertical adjusting capstan nuts for telescope level.  | 53. Binding ring.                               |
| 24. Eyepiece focusing pinion.                             | 54. Inner ring, objective setting.              |
| 25. Sleeve for eyepiece.                                  | 55. Objective lens.                             |
| 26. Eye end ring.   | 56. Outer ring, objective setting.              |
|   | 57. Babbit, for objective end.                  |
|   | 58. Objective slide.                            |
|   | 59. Objective cap.*                             |

\* Not illustrated.

## Hints on Adjustments

Before proceeding with any adjustment, read the following suggestions carefully.

**Making the Adjustments.** Do not attempt to perfect each adjustment the first time as succeeding adjustments may disturb those already made. It is better to keep repeating the entire series until a final check shows each adjustment to be perfect.

**Inspection of Instrument.** Before adjusting any instrument, clean it thoroughly. Dirt in bearings will not permit a true adjustment. If adjusting screws or nuts are dirty they will not hold adjustment very long. Damaged or worn screws should be replaced by new factory parts as soon as possible. Damaged or worn bearings or damaged structural parts should be repaired and refitted at the factory. Clamps, tangent screws, and tangent springs should be clean and the clamp arm should be examined to make sure there is no indentation where the tangent screw presses. Be sure that the instrument is correctly assembled and that the holding screws are set up solidly but not overstrained. The telescope should be clean, the lenses showing objects sharply and without astigmatism. Be sure that the object lens is tight in its setting and that the setting is screwed tightly in its tube. All axis bearing caps should be screwed up to the proper tension. The proper fit of the telescope axle and the elimination of "walk" is very important. Check the level vials to see that they are firm in their cases. Examine the shoes on the tripod to make sure they are tight.

**Select a Suitable Location.** Established offices should provide a substantial pier or wall bracket wherewith to support the instrument when adjusting. Targets and scales should be set at convenient distances and elevations. In a limited space, particularly indoors, telescopes focused at infinity should be set up for use as collimators. On construction work an adjusting site should be selected, targets erected and a stake driven to define the instrument position if a tripod and not a permanent support is used. In selecting such sites, avoid places where the line of sight would pass over a railroad track or paved highway, near a heated building, or through successive areas of light and shadow. Protect the instrument from wind and direct rays of the sun, particularly when they strike only one side of the instrument at a time.

**Setting up the Instrument.** Select a spot where the ground is firm and dry so that moving around the instrument will not disturb it. If the instrument is set on a floor of concrete, brick or stone, make sure that there are no loose sections. Chip holes in a smooth floor to prevent the tripod points from slipping. After screwing the instrument to the tripod, loosen the tripod bolts, then tighten them, in order to remove all residual torque in the tripod head. This helps hold the transit on line. Tighten the leveling screws firmly, but do not force them.

## Transits

The adjustments of transits are as follows:

1. Parallax.
2. Rectify cross wires.
3. Collimation at distant focus.
4. Collimation at minimum focus.
5. Telescope axis.
6. Telescope level.
7. Plate levels.
8. Vertical circle vernier.
9. Center eyepiece.
10. Balance compass needle.
11. Straighten needle
12. Center pivot.

### Description of Transit

The transit, as generally constructed today, serves to measure angles in azimuth and in altitude. It, therefore, consists of two divided circles or limbs, one of which rotates about a vertical axis and the other about a horizontal axis. Each graduated surface is made perpendicular to its axis of rotation. The pointer of the instrument is a telescope, supported by standards and plate, the plate carrying the indices or verniers. The spindle, carrying the plate and standards, and the socket, carrying the horizontal limb, constitute the "centers" which rotate about each other and within the bearing of the leveling head.

The "centers" or vertical axis is made plumb by two spirit levels mounted on the plate. These levels are adjustable, and they can be readily checked by reversal about the centers.

The telescope is mounted with an axle which rides in bearings on top of the standards. For the axle to form a horizontal axis it must be at right angles to the vertical axis, and adjustment is provided for raising or lowering one end of the axle.

The pointer of the telescope is an optical line of sight passing through the optical center of the objective lens and the intersection of the cross wires. This is commonly called the line of collimation. The cross-wire ring is made adjustable so that the line of collimation can be adjusted at right angles to the horizontal axis or telescope axle.

In order to provide a datum for altitude angles, a spirit level is attached to the telescope so that its axis can be adjusted parallel to the line of collimation.

A clear understanding of the relationship between the various axes of a transit is helpful in performing adjustments. Those outlined can be performed by the instrument man; detailed instructions are given on succeeding pages. Errors of eccentricity should be corrected at the factory. Errors of parallax are due to improper manipulation.

**1. Parallax.** *Parallax is eliminated by correct focusing of the objective lens on the cross wires.*

*Owing to differences in eyesight among individual users, it is necessary also to focus the eyepiece on the cross wires. Strictly speaking, this is not an adjustment but rather a manipulation that should be performed each time an accurate pointing is desired. Since incorrect focusing will affect other adjustments involving the use of the telescope, it is listed herein as the first adjustment, and it is important that every detail be followed carefully.*

(a) Sight through telescope and make preliminary focus of eyepiece on cross wires. Turn knurled ring at eye end of telescope, until wires appear black and sharp. (On some transits turn eyepiece cap or possibly an eyepiece pinion on side of telescope.)

*Eye should be relaxed and time of setting should be brief, otherwise the eye may accommodate itself to the telescope rather than the telescope become adjusted to the eye. If both eyes can be left open, a better focus will be obtained.*

(b) Focus the objective lens on a clearly defined, well-lighted target about 300 ft. away. Turn the objective focusing pinion slowly backward and forward of the position of focus, at the same time wagging the head. Observe for apparent lateral movement between target image and cross wires. Stop focusing at the point where no lateral displacement appears. Disregard sharpness of image and of cross wires. It is this objective focusing which is important in the elimination of parallax.

(c) If necessary to sharpen the image, refocus the eyepiece slightly. It will be found that the cross wires also will be more distinct.

(d) Further focusing of the eyepiece will not be necessary unless the eye tires or a different observer uses the instrument, in which event paragraphs b and c should be repeated.

(e) On surveys of a high order, paragraph b should be followed on all pointings if the observer wishes surely to eliminate parallax error due to focusing.

*It may be pointed out that a young man has more trouble than an old man in getting an eyepiece properly focused. This is due to the greater "accommodation" of the younger eye. The above procedure tends to produce a relaxed and normal condition of the eye when setting the final focus of the eyepiece. Furthermore, greater difficulty is experienced with low magnification and with the simple eyepiece of the inverting telescope.*

**2. Rectify Cross Wires.** *To make the vertical cross wire perpendicular to the telescope axis.*

(a) Sight through telescope and set one end of the vertical cross wire on a sharply defined point A, Fig. 26.

(b) Elevate or depress telescope so that vertical wire traces over point. If wire coincides with point throughout its length, its position is correct.

(c) If not, slightly loosen all four capstan screws, located on eyepiece end of telescope.



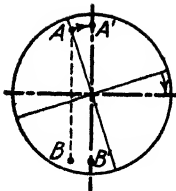

FIG. 26.

(d) Move cross-wire ring around, in proper direction, until test shows that vertical wire exactly traces point. Hold screw driver against each of the collets and tap lightly against it.

(e) Tighten capstan screws and check.

**3. Collimation at Distant Focus.** *To make the collimation plane of the vertical cross wire perpendicular to the telescope axis.*

(a) Set up and sight vertical wire on a sharply defined point *A* (see Fig. 27), 200 or 300 ft. away.

(b) Transit the telescope and set a point *B* at approximately the same elevation and distance as *A*.

(c) Leave the telescope reversed, rotate the transit plate a half turn, and again sight on *A*.

(d) Again transit the telescope (bring it to its normal position), and set point *C*.

(e) Mark a new point *E*, one-quarter the distance from *C* to *B*.

(f) By turning the horizontal capstan screws shift the vertical cross wire until it is set on point *E*.

(g) Again set on *A* and repeat until instrument will make both points, *B* and *C*, coincide at *D*.

(h) Check rectification of vertical wire (refer to section 2).

**4. Collimation at Minimum Focus.** *In most Gurley transits the objective slide rear bearing is adjustable, so that the slide can be made to move parallel to the line of collimation and make it accurate for sighting at all distances. This adjustment is carefully made in the factory and, barring accident to the transit, should require no changing. With Gurley transits having inner-slide focusing any correction necessary can be made in the field; others should be returned to their makers. With internal focusing telescopes this construction is not permitted.*

(a) Set up and sight vertical wire on a sharply defined point, 200 or 300 ft. away.

(b) Place a horizontal scale or rod about 6 ft. in front of telescope (not nearer than point of minimum clear focus), and so that it appears just under the horizontal cross wire in the field of view, without moving the telescope.

(c) Focus on scale and read vertical wire intersection.

(d) Turn transit plate a half turn, transit telescope, and again set vertical wire on distant point.

(e) Without moving telescope, focus on nearby scale and read vertical wire intersection.

(f) If second reading (e) coincides with first reading (c), the objective slide is in adjustment with the vertical wire.

(g) Turn nearby scale or rod to vertical position in field of view and repeat readings using horizontal wire intersection. If two readings coincide, the objective slide is parallel to the horizontal wire.

(h) If not, correct for half the error by moving the rear bearing ring of the objective slide up or down or to the right or left as required. Turn slotted screws near or in telescope axis, using screw driver. Turning screw clockwise draws ring towards screw. Loosen opposite screw first. With an erecting telescope, actual movement should be opposite to apparent movement. With many telescopes, screws are on a  $45^\circ$  angle with respect to the cross wires; hence they are to be turned in pairs in order to move the bearing ring as required.

(i) Repeat sections 3 and 4 until the conditions of both are satisfied.

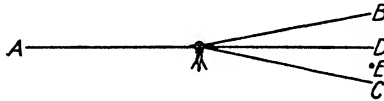

FIG. 27.

**5. Telescope Axis.** *To make the telescope axis perpendicular to the vertical axis or spindle.*

- (a) Set up transit.
- (b) Sight on a high point *A* (see Fig. 28).
- (c) Depress telescope and set point *B* on ground, in front of instrument.
- (d) Rotate instrument  $180^\circ$  and transit telescope.
- (e) With telescope in reversed position, again sight on point *B*.
- (f) Elevate telescope and note point *C*.
- (g) Note a new point *D* halfway between *B* and *C*.
- (h) Raise or lower the right end of the telescope axle until the vertical cross wire intersects the halfway point *D*, when elevating telescope from point *B*.

To raise or lower the telescope axle turn the right-hand threaded capstan headed screw which is to be found under the standard cap on the right-hand side. Turn clockwise to raise, counterclockwise to lower.

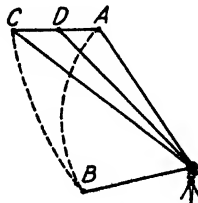

FIG. 28.

Before raising:

*On old-model Gurley Transits:* Loosen cap screws.

*On late-model Gurley Transits:* Loosen capstan screw on top of standard.

After adjusting:

*On old-model Gurley Transits:* Tighten the two cap screws equally until there is sufficient friction on the axle bearing to keep the telescope end from dropping under its own weight. On some models, laminated shims have been placed under the standard cap. In such cases the cap screws should be set up solidly. If the telescope transits too freely, remove laminations from the shims until the proper braking action is arrived at. Check and adjust the cap screws on the left-hand standard so that these provide equal braking power on both ends of telescope axle.

*On late-model Gurley Transits:* Tighten the two capstan screws on top of standards. Adjust both screws equally until there is sufficient braking action on the axle to keep the telescope end from dropping. Check and adjust the capstan screws on the left-hand standard so that they provide equal braking power on both ends of telescope axle.

(i) Check and repeat until transit will make points *A* and *C* coincide.

**6. Telescope Level.** To make the axis of the bubble parallel to the line of sight when the latter is horizontal.

#### The "Four Peg" Method

For the "Two Peg" method, see p. 274

(a) Drive four stakes, *A*, *B*, *C*, and *D*, in line and exactly equidistant, from 50 to 100 ft. apart (see Fig. 29).

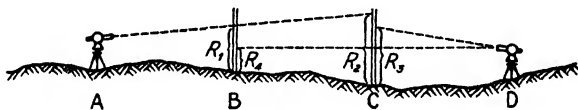

FIG. 29.

- (b) Set up the transit at *A*.  
 (c) Bring the bubble to the center of the telescope level.  
 (d) Read the elevation of the line of sight on a rod held at both *B* and *C*, calling the first reading  $R_1$  and the second  $R_2$ .  
 (e) Set up the transit at *D*.  
 (f) With the bubble in the center of the telescope level, read the rod on *C*, calling it  $R_3$ .  
 (g) Add  $R_1$  to  $R_3$ , subtract  $R_2$ , and set target on rod to this result.

$$R_4 = (R_1 + R_3 - R_2)$$

(h) Hold rod on *B*.

(i) By means of the axis tangent motion, incline the telescope until the horizontal wire intersects the target.

(j) Raise or lower one end of the bubble tube, by turning the capstan nuts, until the bubble returns to the center.

*Reversion Vial: A procedure simpler than the peg method can be employed if the telescope level vial is of the reversion type.*

(a) Set up transit, sight on level rod about 100 ft. distant, and center bubble.

(b) Read level rod (middle horizontal wire).

(c) Rotate instrument  $180^\circ$  in azimuth, transit telescope, again sight on rod, and center bubble.

(d) Read level rod.

(e) Average readings *b* and *d*. Set horizontal wire to average reading on rod. Center bubble by capstan adjusting nuts.

**7. Plate Levels.** *To make the bubble tube axes perpendicular to the vertical axis or spindle.*

(a) Set up transit on tripod.

(b) Rotate transit plate so that each bubble is in line with a pair of opposite leveling screws.

(c) Bring plate level bubbles to the center in both tubes.

(d) Turn the plate through  $180^\circ$  in azimuth.

(e) Note the amount that the bubbles move from the center.

(f) Raise or lower one end of each bubble tube as required to bring the bubbles back one half the amount they moved off.

*To raise or lower one end of the bubble tube:* On transits having capstan nuts above and below level tube, use adjusting pin to raise or lower both nuts as required. Do not force together so as to spring bubble tube.

On transits having a slotted screw at top of adjusting post, use adjusting pin to raise or lower only the capstan nut, underneath the tube. Coiled spring inside tube supplies proper tension. Adjust end of tube which will keep slotted screw about flush with top of tube.

(g) Level up and repeat the above until both bubbles remain in the center when rotating them  $180^\circ$ . *Check and correct the bubbles alternately.*

**8. Vertical Circle Vernier.** *To make the vertical circle (or arc) read zero when the line of collimation is horizontal.*

(a) Level up transit carefully, using telescope level.

(b) Center bubble of telescope level, using axis tangent motion. Check bubble adjustment, section 6.

(c) Inspect vernier and vertical circle to see if zeros of each coincide.

(d) If not, slightly loosen screws which hold vernier to standard.

(e) Shift vernier until zeros coincide.

(f) Tighten vernier screws and check.

*Two-Vernier Vertical Circle. To make the vertical circle read zero when the line of collimation is horizontal.*

- (a) Level up transit carefully, using telescope level.
- (b) Center bubble of telescope level, using axis tangent motion.
- (c) Turn capstan headed screw until zeros of one vernier and vertical circle coincide.

*To make zeros of verniers read  $180^\circ$  apart.*

- (a) Make line of collimation horizontal and also one vernier read zero as described above.
- (b) If opposite vernier does not read zero, slightly loosen the screws which hold that vernier to the vernier frame.
- (c) Shift vernier until zeros coincide.
- (d) Adjust spacing between vernier and circle until end graduations on vernier match with limb.
- (e) Tighten vernier screws and check.

*Beam Stadia Arc Indices. To make indices read zero when vernier reads zero.*

- (a) Set vernier to read zero on limb.
- (b) If indices  $H$  and  $V$  do not read zero, slightly loosen index screws.
- (c) Shift indices until they both read zero.
- (d) Tighten index screws.

**9. Center Eyepiece.** *To make the cross wires appear in the center of the field of view. This adjustment is not an essential to accuracy but is of convenience to the observer.*

- (a) After the cross wires have been adjusted, observe whether they appear in the center of the field.
- (b) If not, unscrew the entire eyepiece from the telescope, turning raised rim ahead of knurled ring.
- (c) Move the eyepiece slide in proper direction (opposite to apparent direction) by means of opposing flat headed screws in eyepiece. Estimate the amount of movement necessary.
- (d) Replace the eyepiece in telescope and, if necessary, repeat until the eyepiece is properly centered.

**10. Balance Compass Needle.** *The compass needle is balanced horizontally, as near as possible, for the locality to which it is sent. The metal spring or bright coiled wire on the south end of the needle slides along the needle to enable the instrument man to do exact balancing in the field. The needle should be tested for balance when the instrument is moved from one locality to another. Balancing at the office, particularly in a large building, will probably not give satisfactory results.*

- (a) Level up the instrument.
- (b) Release the needle on its pivot.
- (c) Remove the compass glass by pressing the palm of the hand flat on the glass and turning counterclockwise.

Some transits have a set screw in the bezel ring, which should be removed before turning ring. This is located in either the NW or SE quadrants. If glass is tight, tap around bezel ring with handle of screw driver to loosen threads. The compass glass cannot be removed from between the standards on some Gurley transits without first detaching the vertical axis tangent bar which is held to the standard by two screws. However, it is unnecessary to remove the compass glass entirely when making adjustments.

(d) Note the dip of the needle, raise one side of the compass glass, and carefully remove the needle. Slide the counterbalance along the needle toward the high end.

(e) Lower the needle on its pivot point as gently as possible.

(f) Repeat until the needle balances.

(g) Replace the compass glass, taking care not to cross the threads. Finish turning with index pointer at *N* position. Replace locating set screw.

(h) Raise the needle from its pivot until ready to use.

**11. Straighten Needle.** *To make both ends of the needle read 180° apart in one position. This makes both ends and the center of the needle lie in the same vertical plane.*

(a) Set up compass, lower needle gently on the center pin, and remove the cover glass.

(b) With a small splinter of wood, bring the north end of the needle exactly opposite the north zero mark of the circle.

(c) Read the south end of the needle.

(d) Rotate the needle a half turn and bring the south end exactly opposite the north zero.

(e) Read the north end of the needle.

(f) If the two readings agree (paragraphs *c* and *e*) the needle is straight.

(g) If not, correct for half the error by bending the needle.

(h) Repeat the test until the needle is straight.

**12. Center Pivot.** *To make both ends of the needle read 180° apart in all positions. This brings the pivot point exactly in the center of the compass circle.*

(a) After straightening needle, bring north end of needle exactly opposite the north zero mark of the circle.

(b) Note whether south end of needle reads zero.

(c) If not, correct for the whole error by bending the center pin in a direction at right angles to the needle. Use wrench, carried in spare parts kit, to bend center pin.

(d) Rotate the needle a quarter turn, bring the north end opposite a 90° mark, and note whether the south end of the needle reads 90°.

(e) If not, correct for the whole error by bending the center pin in a direction at right angles to the needle.

(f) Repeat the above, reading first at the zero and then at the 90° marks, until both ends of the needle read alike in both positions.

## Levels

### Adjustments of Wye Levels

The adjustments of Gurley wye levels are as follows:

1. Parallax.
2. Rectify cross wires.
3. Collimation at distant focus.
4. Collimation at minimum focus.
5. Telescope level vial.
6. Wyes.
7. Center eyepiece.

### Adjustments of Dumpy Levels

The adjustments of Gurley dumpy levels are as follows:

1. Parallax.
2. Telescope level vial.
3. Rectify cross wires.
4. Collimation at distant focus.
5. Collimation at minimum focus.
6. Center eyepiece.

A level is an instrument used to determine the position of all points in a horizontal plane. It consists of a collimated line of sight adjusted parallel to the axis of a spirit bubble. This fundamental description should be kept in mind when adjusting and using a level of any type.

The type of level is determined from the structural arrangement of the parts necessary to adjust the axis of the bubble parallel to the line of sight and the convenience of keeping the bubble centered when taking a reading.

With the wye level, the telescope is provided with two accurately machined bearing rings, truly circular and of equal diameter, separated by about half the length of the telescope. These rest in wye bearings which are adjustable in the wye bar, which is permanently fixed at right angles to the vertical spindle. Two level posts attached to the telescope (usually underneath) carry the level vial, the position being fixed by adjusting nuts, usually at both ends.

With the dumpy level, the telescope, bar, and spindle are assembled as one unit, the workmanship being such that the axis of the telescope is closely perpendicular to the vertical axis of rotation or spindle. Level posts may be attached either to the bar or to the telescope, these carrying the level vial with adjusting nuts at both ends.

This difference in construction between the wye and dumpy level determines a difference in adjustment procedure. Thus, with the wye level, the collimated line of sight is made concentric with the wye rings by rotating the telescope in the wyes and adjusting the reticule carrying the cross wires. By reversing the telescope rings and for end in the wye bearings, and by adjusting the level vial in the level posts until the bubble

holds its central position in both positions of the telescope, the bubble axis is made parallel with the wye rings and thereby parallel with the collimated line of sight. As long as this parallelism holds, it is possible to do accurate leveling with a wye level, provided the level bubble is made central by the leveling screws each time a reading is taken. For convenience in keeping the bubble centered when pointing the telescope in a new direction, the wye adjustment is provided, which, by reversing the telescope about its spindle and by adjusting the wye nuts, makes the bubble axis, also the collimated line of sight, perpendicular to the spindle, or axis of rotation. When making the latter adjustment, the telescope slide should be moved by the focusing screw until the objective end of the telescope balances the eyepiece end. This position of the slide should be noted and the slide brought back to it when subsequently leveling up the instrument. Any movement of the slide from this position changes the balance of the instrument and may cause the bubble to run. This condition does not indicate a change in adjustment, since nothing has been done to change the parallelism between the bubble axis and the collimated line of sight. Therefore such a run of the bubble should be corrected by the leveling screws.

In adjusting the dumpy level, the construction necessitates a different procedure. The level bubble axis is first made perpendicular to the spindle or axis of rotation by reversing the telescope end for end about the spindle, centering the bubble by the level post adjusting nut. The collimated line of sight is then brought parallel to the bubble axis by the peg method of adjustment, the details of which are given on p. 274. For careful adjustment the objective slide should be at the position of balance, and any subsequent run of the bubble should be compensated for by the leveling screws, as explained under the wye level paragraph above.

When using a level, the adjustment or parallelism between bubble axis and collimated line of sight is important but it is equally important to make sure that the bubble is centered each time a reading is taken. To assist in this purpose, various devices from a simple mirror to a complicated prism system are used to enable the observer to see the position of the bubble at the time he reads on the rod.

The tilting type of level has been devised to assist the observer in keeping the bubble centered without recourse to the leveling screws. In addition to the change in balance caused by focusing on rods at different distances, there are other factors which cause a bubble to run without disturbing the fundamental parallelism between bubble axis and line of sight, especially so if a sensitive bubble is used.

The tilting level (used for precise leveling) has a double bar, one part attached parallel to the telescope, the other part at right angles to the spindle. The two bars are arranged to pivot one on the other, being separated by a slow-motion screw with opposing spring. A circular or bull's-



eye level on the bar or leveling head serves to plumb the spindle. Final leveling with each reading is done by centering the bubble by the slow-motion screw. Such levels are generally provided with a reflecting device so that both bubble and rod image are visible at the same time.

Tilting levels may be either of the dumpy or of the wye type. In the dumpy type, the parallelism between the bubble axis is established by the peg method of adjustment. In the wye type, the telescope is made with wye rings and with a reversion type of level attached to the side. The advantage of the wye or reversible type of tilting level is the ease of adjusting the line of collimation and the level bubble.

The relative advantages of the wye and dumpy levels boil down to a matter of individual preference. The dumpy level with fewer parts is supposed to remain in adjustment over a longer period of time. However, its adjustment is dependent upon a well-fitted spindle and socket.

The advantage claimed for the wye level is that the adjustments can be checked readily by one person (the dumpy level requires the assistance of a rodman in making the peg adjustment). The principal objection is that the adjustments are dependent upon the wye bearing rings being truly circular and equal in diameter. Since the rings are exposed to wear and to possible damage, some engineers feel that they cannot be sure of the adjustment unless the peg method is used anyway.

For construction engineering the compact solidarity of either the wye or the dumpy level gives these types the preference. However, for accuracy and speed on long lines of differential levels the tilting type is superior.

**1. Parallax.** See *parallax adjustment for transit*, p. 261.

**2. Rectify Cross Wires.** *To make the horizontal cross wire perpendicular to the vertical axis or spindle. The vertical wire is set perpendicular to the horizontal wire by the maker.*

(a) Set up a level on tripod. Set one end of horizontal wire on a sharply defined point *A*, Fig. 30.

(b) Turn level slowly about its spindle, so that horizontal wire traces over the point. Wire should coincide with point throughout its length.

(c) If point appears to trace dotted line *AB*, Fig. 30, slightly release pressure on capstan screws. Turn all four capstan screws only slightly and by equal amounts.

(d) Gently tap capstan screws in direction to close angle between horizontal wire and dotted line *AB*, Fig. 30. Rotate cross-wire ring (test, paragraph *b* above) until horizontal wire exactly traces point from *A'* to *B'*, Fig. 30.

(e) Tighten capstan screws (all four equally), and check.

**3. Collimation at Distant Focus.** *To make the line of sight (collimation) pass through the axis of the wye rings.*

(a) Set up level on tripod, remove wye pins from clips, and raise clips so that telescope is free to rotate.

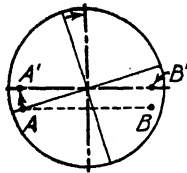

FIG. 30.

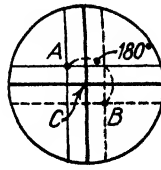

FIG. 31.

(b) Set intersection of cross wires on a well-defined point (*A*, Fig. 31), about 300 ft. distant.

(c) Carefully rotate the telescope halfway around in its wyes, and note whether the intersection of the cross wires still covers the point.

(d) If not, move the telescope by leveling and tangent screws until the error seems to be one-half corrected.

(e) Move the cross-wire ring, using each pair of opposite capstan screws successively, until the error is entirely corrected and the cross-wire intersection now covers the point (*C*, Fig. 31).

(f) Repeat the rectification (2) and collimation (3) of the cross wires until both adjustments are correct.

**4. Collimation at Minimum Focus.** *To make the objective slide move parallel to the line of collimation when racked in or out for focusing on distant or near targets.*

*This adjustment may be checked on any telescope but can be corrected only on Gurley inner-slide focusing telescopes. It is not on internal focusing telescopes or on the external focusing telescopes of other makes. It is primarily a factory adjustment and, barring accident, should need no correction in the field.*

(a) Set up level on tripod, remove wye pins from clips, and raise clips so that telescope is free to rotate.

(b) Check adjustment of the line of collimation (3) for a remote target.

(c) Unscrew the cover ring in center of telescope, exposing the flat-headed screws for adjusting the rear bearing of the objective slide.

(d) Set intersection of cross wires on a well-defined point about 15 ft. distant.

(e) Carefully rotate telescope halfway round in its wyes, and note whether the intersection of the cross wires still covers the point.

(f) If not, move the telescope by leveling and tangent screws until the error seems to be one-half corrected.

(g) Correct the remainder of the error by turning the flat-headed screws with a screw driver until the cross wires intersect on the point. Adjust first one pair of screws and then the other. Loosen one screw and tighten the other.

(h) Repeat sections 3 and 4 until the conditions of both are satisfied.

(i) Replace cover ring.

**5. Telescope Level Vial.** *To make the axis of the bubble parallel to and in the same vertical plane with the axis of the wye rings. As long as this adjustment and section 3 are correct, accurate leveling can be done with the instrument.*

(a) Hold level sideways with spindle horizontal, and turn focusing screw until level balances. Then set up on tripod, clamp telescope over two diagonally opposite leveling screws.

(b) Remove wye pins and raise wye clips.

(c) Bring bubble to center of tube (see Fig. 32).

(d) Lift telescope out of wyes, turn end for end, and replace in wyes. Note whether bubble remains in center of tube (see Fig. 33).

(e) If not, bring bubble halfway back to center by the leveling screws.

(f) Correct balance of error by turning the capstan nuts at eyepiece end of bubble tube until bubble returns to center (see Fig. 34).

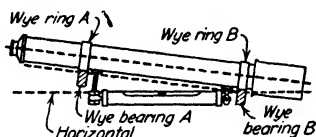

FIG. 32.

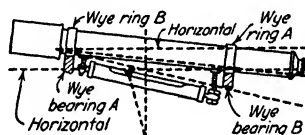

FIG. 33.

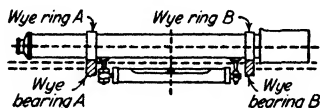

FIG. 34.

(g) Rotate telescope in its wyes, about  $30^\circ$  either side of the vertical, and note whether bubble remains in center of tube.

(h) If not, bring bubble all the way back to center by turning the lateral capstan screws on each side of the bubble tube post at the objective end of the level.

(i) Repeat the vertical adjustment, as given under section 5, paragraphs c, d, e, and f above.

(j) Check alternately until both the lateral adjustment and the vertical adjustment of the vial are correct.

*Note: Bubble will run if balance is changed, by running objective slide in or out. This does not indicate adjustment is out. See p. 269.*

**6. Wyes.** *To make the axis of the wyes perpendicular to the vertical axis or spindle.*

*This adjustment is made as a convenience, rather than as a necessity. Accurate leveling can be done if the bubble is in adjustment, and is centered by the leveling screws before each rod reading.*

(a) Set up level, rotate about spindle until telescope is over two diagonally opposite leveling screws, and bring bubble to the center of tube (see Fig. 35). Check telescope bubble adjustment, section 5, very carefully. Telescope slide must be in position of balance.

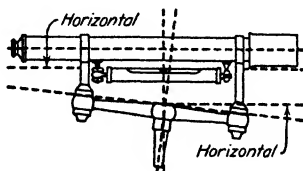

FIG. 35.

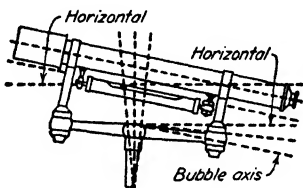

FIG. 36.

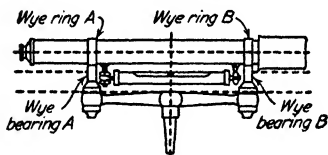

FIG. 37.

(b) Rotate level about spindle  $180^\circ$ , and note whether bubble remains in center of tube (see Fig. 36).

(c) If not, bring bubble halfway back to the center by the leveling screws. Raise or lower one end of the wye bar, until the bubble returns to the center, by turning a pair of capstan nuts at either end of the wye bar.

(d) Repeat until the bubble remains in center of tube when rotated about spindle (see Fig. 37).

**7. Center Eyepiece.** *To make cross wires appear in center of field.*

*This is not essential to the accuracy of the work, but it is a convenience to the observer to have the cross wires appear in the center of the field.*

(a) Set up level, and observe whether cross wires appear in center of field.

(b) If not, unscrew cover ring between cross wires and eye end of telescope.

(c) Turn the flat-headed screws with a screw driver until the cross wires appear in the center of the field.

*Adjust first one pair of screws, and then the other. Loosen one screw and tighten the opposite one. Correct in a direction opposite to the apparent error.*

(d) Replace cover ring.

### Adjustments of Dumpy Levels

**1. Parallax.** *See parallax adjustment for transit, p. 261.*

**2. Telescope Level Vial.** *To make the axis of the bubble perpendicular to the vertical axis or spindle.*

(a) Set up level on tripod, rotate about spindle until telescope is over two diagonally opposite leveling screws, and bring bubble to center of tube.

(b) Rotate level about spindle  $180^\circ$ , and note whether bubble remains in center of tube.

(c) If not, bring the bubble halfway back to the center by the leveling screws.

(d) Correct balance of error by turning capstan nuts at either end of bubble tube, until bubble returns to center.

(e) Alternate over both pairs of leveling screws until the bubble remains in center of tube when rotated about spindle.

**3. Rectify Cross Wires.** *To make the horizontal cross wire perpendicular to the vertical axis or spindle. Vertical wires are set by the maker at right angles to the horizontal wire.*

(a) Set up level on tripod, and set one end of horizontal cross wire on a sharply defined point ( $A$ , Fig. 30).

(b) Turn level slowly about its spindle, so that horizontal wire traces over the point. If wire coincides with point throughout its length, its position is correct.

(c) If not, slightly loosen all four capstan screws located on eyepiece end of telescope.

(d) Move cross-wire ring around, in proper direction, until test shows that horizontal wire exactly traces point ( $A' B'$ , Fig. 30).

(e) Tighten capstan screws and check.

**4. Collimation at Distant Focus.** *To make the line of sight parallel to the axis of the bubble.*

#### *The "Two Peg" Method*

*For the "Four Peg" method, see p. 264.*

(a) Set up level at some convenient point  $A$ , Fig. 38, holding rod at  $C$ , distant at least 100 ft. With instrument carefully leveled and bubble in center of telescope level, read rod on  $C$ , calling the reading  $R_c$ .

(b) Locate point  $B$  directly behind instrument and so that distance  $AB$  equals  $AC$ .

(c) Point telescope toward  $B$ , bring bubble to center of telescope tube, and take rod reading  $R_b$ .

(d) Set up level beside point *B*, so that eyepiece of telescope is directly over point. Level up carefully, bringing bubble to center of telescope tube.

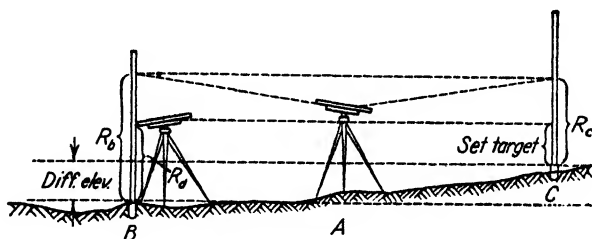

FIG. 38.

(e) Point eyepiece of telescope toward rod at *B*, and read through objective end of telescope, calling this reading  $R_a$ . If more convenient, measure along the outside center line of telescope.

(f) Add to  $R_a$  the difference between the first readings ( $R_c - R_b$ ).

(g) Set rod target to this result, and hold the rod on point *C*.

(h) Move the cross-wire ring up or down until the horizontal wire cuts the target, by turning the vertical pair of opposite capstan screws.

(i) Check by again reading rod on *B*, computing rod reading for *C*, and observing whether horizontal wire cuts the target.

**5. Collimation at Minimum Focus.** To make the objective slide move parallel to the line of collimation when racked in or out for focusing on distant or near targets.

This adjustment may be checked on any telescope but can be corrected only on Gurley inner-slide focusing telescopes. It is not on internal focusing telescopes or on the external focusing telescopes of other makes. It is primarily a factory adjustment and, barring accident, should need no correction in the field.

(a) After doing section 4, set up level about 15 ft. from *B* (Fig. 38) toward *C*, which is the same distance away.

(b) On old-model Gurley dumpy levels unscrew the cover ring in center of telescope, exposing the flat-headed screws for adjusting the rear bearing of the objective slide.

(c) Level carefully and read rod *C*.

(d) Rotate level and focus on rod *B*. Moving objective slide out will probably cause the bubble to run, owing to the change in balance. Bring the bubble to the center by turning the leveling screws.

(e) Set target on rod *B* to proper reading to give true difference in elevation ( $R_c - R_b$ ) as determined in section 4. Cross wires should bisect target at this setting.

(f) If not, turn the flat-headed screws, moving the rear bearing up or down, until the horizontal wire cuts the target.

(g) Check sections 4 and 5 alternately, until both are correct.

**6. Center Eyepiece.** *To make the cross wires appear in the center of the field of view. This adjustment is not an essential to accuracy but is of convenience to the observer.*

(a) After the cross wires have been adjusted, observe whether they appear in the center of the field.

(b) If not, unscrew the entire eyepiece from the telescope, turning raised rim ahead of knurled ring.

(c) Move the eyepiece slide in proper direction (opposite to apparent direction) by means of opposing flat-headed screws in eyepiece. Estimate the amount of movement necessary.

(d) Replace the eyepiece in telescope, and, if necessary, repeat until the eyepiece is properly centered.

### Taping

#### Changes in Temperature

Correction in feet =  $C \times L(T - T_s)$ .

$C = 0.0000065$  for steel tape.

$C = 0.0000056$  for invar. tape.

$L =$  length of tape in feet.

$T =$  temperature in degrees Fahrenheit at which tape is used.

$T_s =$  temperature at which tape was standardized ( $62^\circ$  F. or  $68^\circ$  F.).

#### Variation in Tension

Correction in feet =  $\frac{(P - P_s)L}{AE}$ .

$P =$  tension applied.

$P_s =$  standard tension (10 to 15 lb.).

$L =$  length of tape in feet.

$A =$  cross section area of tape in square inches (light steel tape =  $0.0025 \pm$ ; heavy steel tape =  $0.01 \pm$ ).

$E =$  modulus of elasticity in pounds per square inch (30,000,000 for steel tapes).

#### Sag

Correction in feet between points of support =  $\frac{W^2L}{24P^2}$ .

$W =$  weight of tape in pounds between supports (a light tape =  $1.0 \pm$  lb. per 100 ft.; a heavy tape =  $3.0 \pm$  per 100 ft.).

$L =$  length in feet between supports.

$P =$  tension used in pounds.

# MAPPING

## PLOTting TRAVERSES

### 1. Plotting by Protractor

**Procedure.** Fix position of first line, and lay off its length  $AB$  by

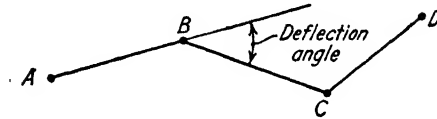

scaling. Orient the protractor at the forward point  $B$ ; lay off the deflection angle to the succeeding line, and draw a light line of indefinite length. Scale off the given distance  $BC$  to the next traverse point  $C$ , etc.

**Hints and Precautions.** Orient the position of the first line so that the succeeding lines will not run off the paper. Carefully check the deflection angles as to their direction right or left. Calculated bearings should check reasonably with observed magnetic bearings. When azimuths or calculated bearings are used, a meridian line may be drawn through each station and the direction of the succeeding line laid off from the meridian.

### 2. Plotting by Tangents

**Procedure.** Fix position of first line, and lay off its length  $AB$  by

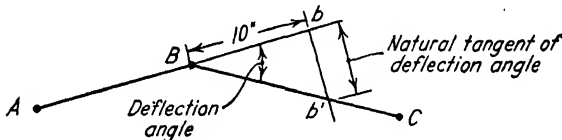

scaling. Prolong the line  $AB$  some convenient distance, to form a base line  $Bb$ . Erect a perpendicular  $bb'$  of sufficient length. Scale off the distance  $bb'$  equal to the length of the base line  $Bb$  multiplied by the natural tangent of the deflection angle. Draw a line from  $B$  through  $b'$  to define the direction of  $BC$ , etc.

**Hints and Precautions.** Time and accuracy can be gained by laying off the base line  $Bb$  10 in. in length and scaling off the natural tangent along the perpendicular with an engineer's scale. Because the 50 scale has more graduations than the 10 scale, it is customary to scale off one-half the natural tangent with the 50 scale. Scale all distances and erect all perpendiculars carefully. Where the deflection angle is greater than  $90^\circ$  the perpendicular is erected by measuring the base line back on the course from the last point and scaling off the tangent for  $180^\circ$ —the deflection angle. When the deflection angle is greater than  $45^\circ$ , erect a perpendicular from the last point set, scale off a 10-in. base line, and erect a line parallel to the last course, along which scale off the cotangent of the deflection angle. Check all plotted angles with a protractor. For in-



creased accuracy the base lines may be made 20 in. and the tangents scaled direct with the 50 scale. For checking the erected perpendiculars the diagonal distance on the hypotenuse of the 10-in. sides should scale 14.14 in.

### 3. Plotting by Chords

**Procedure.** Proceed the same as in plotting by tangents except that, instead of erecting a perpendicular at the end of the 10-in. base line, describe an arc of 10-in. radius. Scale the chord distance  $bb'$ . Draw a

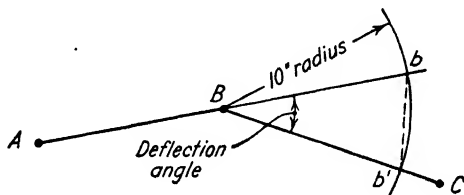

line through  $Bb'$ , and plot the distance  $BC$ . The length of the chord  $bb'$  is equal to  $20 \cdot \sin \frac{1}{2}$ , the deflection angle.

**Hints and Precautions.** In swinging the 10-in. arc use a beam compass or improvise one by inserting a needle point and a pencil point exactly 10 in. apart in a thin strip of wood. If a table of chords is available no computations are necessary. Check the plotted angles with a protractor.

### 4. Plotting by Rectangular Coordinates—Latitudes and Departures

**Procedure.** (1) Transpose the survey data to a computation book as shown in the sample form on p. 247. (2) Compute the latitudes and departures of the courses, and, if a closed traverse, balance the survey. Assume one of the traverse points as the origin of coordinates, calculate total latitudes and departures, and check the computations. (3) Determine the size of the enclosing rectangle, the four sides of which pass through the eastern, western, northern, and southern points of the traverse. (4) Plot the enclosing rectangle to required scale on drawing paper, estimating its position on the sheet by means of a small-scale sketch. Place the traverse symmetrical with the sheet (the sides of the rectangle may or may not be parallel to the edges of the paper). (5) Test the accuracy of the plotting by scaling the length of diagonals. Plot the reference meridian, and plot and check the reference parallel. (6) Construct coordinate lines (other meridians and parallels) so that the area will be divided in squares with sides less than the length of the scale to be used. Number each of these lines with its distance from the reference meridian or parallel. (7) Locate each traverse point by plotting its lati-

tude and departure. (8) Check the length of the traverse lines connecting the points by scaling, and check the angles with the protractor.

**Hints and Precautions.** Accurately construct the meridians and parallels. After the enclosing triangle has been constructed and adjusted by trial the other lines should be plotted entirely by scaling. Do not use a T-square and triangles in the usual way but use straightedges only. The best way to lay out the rectangle and coordinates is with a beam compass and steel straightedge, checking all rectangles by diagonals. If the southwest corner of the enclosing rectangle is taken as the origin of coordinates, all the total latitudes and departures will be positive.

**Practical Applications.** Plotting by coordinates is the best method for plotting most traverses. When the area of a closed traverse is to be computed the latitudes and departures are necessary. The size and shape of the drawing can be determined before plotting. Errors of plotting are not cumulative. The method of checking is simple, and in closed traverses the survey is balanced before plotting.

## PLOTTING TOPOGRAPHY

### 1. Stadia Topography by Protractor

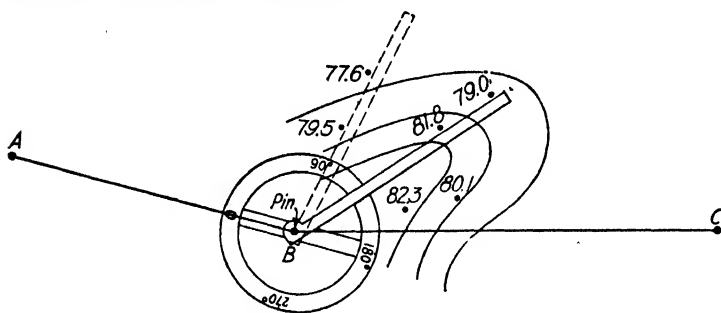

**Procedure.** First lay out the traverse from which topography was taken. To facilitate plotting use a full circle protractor and a scale that can be pinned at the center. Orient the zero of the protractor on the line to the point on which the transit was sighted in the field. Move the scale to the horizontal angle desired and lay off the horizontal distance.

**Hints and Precautions.** One way of marking points as they are plotted is to note the elevation; another is to note the number of the point. Points which are to be connected should be connected before beginning a new station, i.e., points along a road, corners of a building, etc. When each traverse point occupied requires the plotting of a considerable number of points, speed and accuracy will be attained by two persons working as a team, one reading the notes and the other plotting the points.

# MAPPING SYMBOLS \*

FENCES AND WALLS	BOUNDARY LINES
<p>In General <span style="float: right;">(State type)</span> _____</p> <p>Woven Wire <span style="float: right;"></span></p> <p>Barbed Wire <span style="float: right;"></span></p> <p>Board Fence <span style="float: right;"></span></p> <p>Picket Fence <span style="float: right;"></span></p> <p>Rail Fence <span style="float: right;"></span></p> <p>Stone Wall <span style="float: right;"></span></p> <p>Retaining Wall <span style="float: right;"></span></p> <p>Hedge <span style="float: right;"></span></p>	<p>In General <span style="float: right;">(State type)</span> _____</p> <p>Property Line <span style="float: right;"></span></p> <p>Street Line <span style="float: right;"></span></p> <p>Curb Line <span style="float: right;"></span></p> <p>Easement Line <span style="float: right;"></span></p> <p>National, State <span style="float: right;"></span></p> <p>County <span style="float: right;"></span></p> <p>City or Town <span style="float: right;"></span></p>
<p><b>STRUCTURES</b></p> <p>Buildings (Large Scale) <span style="float: right;"></span></p> <p>Buildings (Small scale) <span style="float: right;"></span></p> <p>Barn or Garage <span style="float: right;"></span></p> <p>Bridge <span style="float: right;"></span></p> <p>Dam <span style="float: right;"></span></p> <p>Tunnel <span style="float: right;"></span></p>	<p style="text-align: center;"><b>SURVEY SYMBOLS</b></p> <p>Transit Station <span style="float: right;"></span></p> <p>Stadia Station <span style="float: right;"></span></p> <p>Triangulation Station <span style="float: right;"></span></p> <p>Bench Mark <span style="float: right;"><math>\frac{B.M.}{x}</math> or 481 x B.M.</span></p>
<p style="text-align: center;"><b>ROADS AND RAILROADS</b></p> <p>Path of trail <span style="float: right;"></span></p> <p>Secondary Road <span style="float: right;"></span></p> <p>Improved Road <span style="float: right;"></span></p> <p>Single Track R.R. <span style="float: right;"></span></p> <p>Double Track R.R. <span style="float: right;"></span></p>	<p style="text-align: center;"><b>MISCELLANEOUS</b></p> <p>Stone Bound <span style="float: right;"></span></p> <p>Monument <span style="float: right;"></span></p> <p>Tree (State size and species) <span style="float: right;"></span></p> <p>Edge of Woods <span style="float: right;"></span></p> <p>Ledge <span style="float: right;"></span></p> <p>Stream <span style="float: right;"></span></p> <p>Wire Line <span style="float: right;"></span></p> <p>Power Line <span style="float: right;"></span></p>

\* From Tracy, *Surveying Theory and Practice*, John Wiley & Sons.

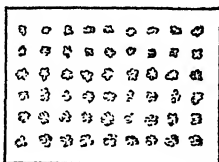

Orchard

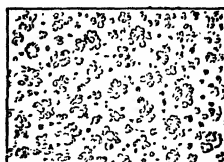

Deciduous Trees

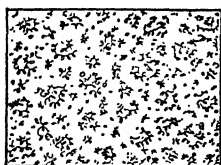

Oak Trees

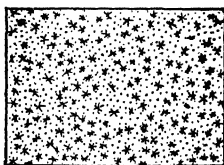

Pine Trees

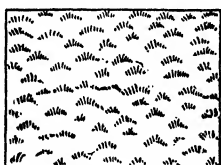

Meadow Land



Fresh Marsh and Pond



Wooded Marsh

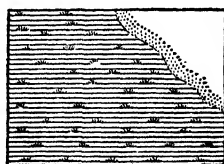

Salt Marsh

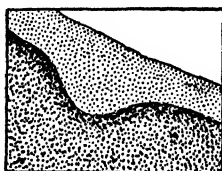

Sand-High and Low Water

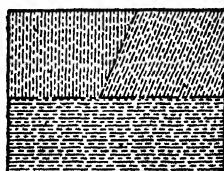

Cultivated Land

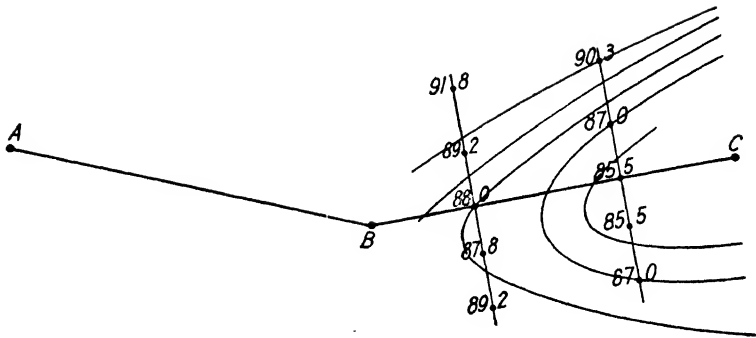

## 2. Topography from Cross Sections

**Procedure.** Indicate the line of cross sections by drawing a light line on the map. Scale off the distance right or left from the base line and mark the elevation.

**Hints and Precautions.** Orient the base line so that right on the map corresponds to right in the notes.

## GENERAL TABLES AND INFORMATION

### LAND MEASURE \*

A rod is  $16\frac{1}{2}$  feet.  
 A chain is 66 feet or 4 rods.  
 A mile is 320 rods, 80 chains, or 5280 feet.  
 A square rod is  $272\frac{1}{4}$  square feet.  
 An acre contains 43,560 square feet.  
 An acre contains 160 square rods  
 An acre is about  $208\frac{3}{4}$  feet square.

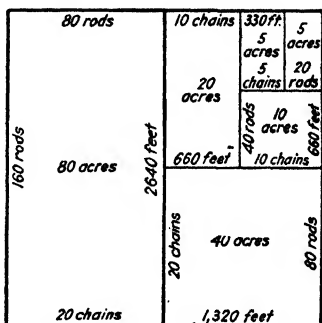

\* From *Water Works & Sewerage*, Vol. 91, No. 6, June 1944.

### TRIGONOMETRIC FORMULAS \*

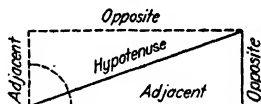

Functions of Angle	Opposite	Adjacent	Hyp
$\sin = \text{Op} \div \text{Hyp}$ $\cos = \text{Ad} \div \text{Hyp}$ $\tan = \text{Op} \div \text{Ad}$ $\cot = \text{Ad} \div \text{Op}$ $\sec = \text{Hyp} \div \text{Ad}$ $\text{cosec} = \text{Hyp} \div \text{Op}$	$\text{Hyp} \times \sin$  $\text{Ad} \times \tan$ $\text{Ad} \div \cot$  $\text{Hyp} \div \text{cosec}$	$\text{Hyp} \times \cos$ $\text{Op} \div \tan$ $\text{Op} \times \cot$ $\text{Hyp} \div \sec$	$\text{Op} \div \sin$ $\text{Ad} \div \cos$  $\text{Ad} \times \sec$ $\text{Op} \times \text{cosec}$

\* Data by American Bridge Co., from *Manual of Structural Design* by Singleton.

## TRIGONOMETRIC FORMULAS

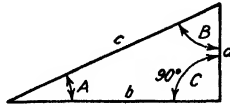

Given	To Find	Formula
$ab$	$A$	$\tan = a \div b$ $\cot = b \div a$
$ab$	$B$	$\cot = a \div b$ $\tan = b \div a$
$ac$	$A$	$\sin = a \div c$ $\operatorname{cosec} = c \div a$
$ac$	$B$	$\cos = a \div c$ $\sec = c \div a$
$bc$	$A$	$\sec = c \div b$ $\cos = b \div c$
$bc$	$B$	$\operatorname{cosec} = c \div b$ $\sin = b \div c$
$Aa$	$b$	$a \cot A$ $a \div \tan A$
$Aa$	$c$	$a \operatorname{cosec} A$ $a \div \sin A$
$Ab$	$a$	$b \tan A$ $b \div \cot A$
$Ab$	$c$	$b \sec A$ $b \div \cos A$
$Ac$	$a$	$c \sin A$ $c \div \operatorname{cosec} A$
$Ac$	$b$	$c \cos A$ $c \div \sec A$

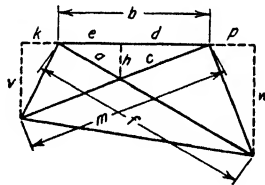

Given	To Find	Formula
$bpw$	$f$	$\sqrt{(b+p)^2 + w^2}$
$bkw$	$m$	$\sqrt{(b+k)^2 + v^2}$
$bkp$	$d$	$bw(b+k) \div [v(b+p) + w(b+k)]$
$vw$	$e$	$bv(b+p) \div [v(b+p) + w(b+k)]$
$bfk$ } $pvw$ }	$a$	$fbv \div [v(b+p) + w(b+k)]$
$bkm$ } $pvw$ }	$c$	$bmw \div [v(b+p) + w(b+k)]$
$bkpvw$	$h$	$bvw \div [v(b+p) + w(b+k)]$
$afw$	$h$	$aw \div f$
$cmv$	$h$	$cv \div m$

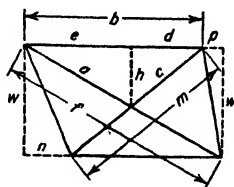

Given	To Find	Formula
$bpw$	$f$	$\sqrt{(b+p)^2 + w^2}$
$bnw$	$m$	$\sqrt{(b-n)^2 + w^2}$
$bnp$	$d$	$b(b-n) \div (2b+p-n)$
$bnp$	$e$	$b(b+p) \div (2b+p-n)$
$bfnp$	$a$	$bf \div (2b+p-n)$
$bmnp$	$c$	$bm \div (2b+p-n)$
$bnpw$	$h$	$bw \div (2b+p-n)$
$afw$	$h$	$aw \div f$
$cmw$	$h$	$cw \div m$

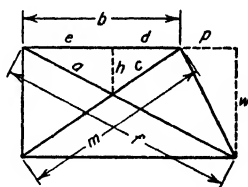

Given	To Find	Formula
$bpw$	$f$	$\sqrt{(b+p)^2 + w^2}$
$bw$	$m$	$\sqrt{b^2 + w^2}$
$bp$	$d$	$b^2 \div (2b+p)$
$bp$	$e$	$b(b+p) \div (2b+p)$
$bf p$	$a$	$bf \div (2b+p)$
$bm p$	$c$	$bm \div (2b+p)$
$bpw$	$h$	$bw \div (2b+p)$
$afw$	$h$	$aw \div f$
$cmw$	$h$	$cw \div m$



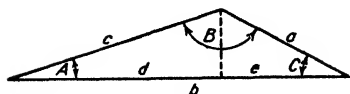

$$s = \frac{a + b + c}{2}$$

Given	To Find	Formula
<i>ABa</i>	<i>b</i>	$a \sin B \div \sin A$
<i>ABa</i>	<i>c</i>	$a \sin (A + B) \div \sin A$
<i>ABb</i>	<i>a</i>	$b \sin A \div \sin B$
<i>ABb</i>	<i>c</i>	$b \sin (A + B) \div \sin B$
<i>ABc</i>	<i>a</i>	$c \sin A \div \sin (A + B)$
<i>ABc</i>	<i>b</i>	$c \sin B \div \sin (A + B)$
<i>ACa</i>	<i>b</i>	$a \sin (A + C) \div \sin A$
<i>ACa</i>	<i>c</i>	$a \sin C \div \sin A$
<i>ACb</i>	<i>a</i>	$b \sin A \div \sin (A + C)$
<i>ACb</i>	<i>c</i>	$b \sin C \div \sin (A + C)$
<i>ACc</i>	<i>a</i>	$c \sin A \div \sin C$
<i>ACc</i>	<i>b</i>	$c \sin (A + C) \div \sin C$
<i>BCa</i>	<i>b</i>	$a \sin B \div \sin (B + C)$
<i>BCa</i>	<i>c</i>	$a \sin C \div \sin (B + C)$
<i>BCb</i>	<i>a</i>	$b \sin (B + C) \div \sin B$
<i>BCb</i>	<i>c</i>	$b \sin C \div \sin B$
<i>BCc</i>	<i>a</i>	$c \sin (B + C) \div \sin C$
<i>BCc</i>	<i>b</i>	$c \sin B \div \sin C$
<i>abc</i>	<i>S</i>	$(a + b + c) \div 2$
<i>abc</i>	<i>A</i>	$\sin \frac{1}{2}A = \sqrt{\frac{(s-b)(s-c) \div bc}{s}}$
<i>abc</i>	<i>A</i>	$\cos \frac{1}{2}A = \sqrt{\frac{s(s-a) \div bc}{s}}$
<i>abc</i>	<i>A</i>	$\tan \frac{1}{2}A = \sqrt{\frac{(s-b)(s-c) \div s(s-a)}{s}}$
<i>abc</i>	<i>B</i>	$\sin \frac{1}{2}B = \sqrt{\frac{(s-a)(s-c) \div ac}{s}}$
<i>abc</i>	<i>B</i>	$\cos \frac{1}{2}B = \sqrt{\frac{s(s-b) \div ac}{s}}$
<i>abc</i>	<i>B</i>	$\tan \frac{1}{2}B = \sqrt{\frac{(s-a)(s-c) \div s(s-b)}{s}}$
<i>abc</i>	<i>C</i>	$\sin \frac{1}{2}C = \sqrt{\frac{(s-a)(s-b) \div ab}{s}}$
<i>abc</i>	<i>C</i>	$\cos \frac{1}{2}C = \sqrt{\frac{s(s-c) \div ab}{s}}$
<i>abc</i>	<i>C</i>	$\tan \frac{1}{2}C = \sqrt{\frac{(s-a)(s-b) \div s(s-c)}{s}}$
<i>abc</i>	<i>d</i>	$(b^2 + c^2 - a^2) \div 2b$
<i>abc</i>	<i>e</i>	$(a^2 + b^2 - c^2) \div 2b$
<i>Aab</i>	<i>B</i>	$\sin = b \sin A \div a$
<i>Aac</i>	<i>C</i>	$\sin = c \sin A \div a$
<i>Bab</i>	<i>A</i>	$\sin = a \sin B \div b$
<i>Bbc</i>	<i>C</i>	$\sin = c \sin B \div b$
<i>Cac</i>	<i>A</i>	$\sin = a \sin C \div c$
<i>Cbc</i>	<i>B</i>	$\sin = b \sin C \div c$
<i>Abc</i>	$\frac{1}{2}(B + C)$	$90^\circ - \frac{1}{2}A$

Given	To Find	Formula
<i>Abc</i>	$\frac{1}{2}(B - C)$	$\tan = [(b - c) \tan (90^\circ - \frac{1}{2}A)] \div (b + c)$
<i>Abc</i>	<i>B</i>	$\frac{1}{2}(B + C) + \frac{1}{2}(B - C)$
<i>Abc</i>	<i>C</i>	$\frac{1}{2}(B + C) - \frac{1}{2}(B - C)$
<i>Abc</i>	<i>a</i>	$\sqrt{b^2 + c^2 - 2bc \cos A}$
<i>Bac</i>	$\frac{1}{2}(A + C)$	$90^\circ - \frac{1}{2}B$
<i>Bac</i>	$\frac{1}{2}(A - C)$	$\tan = [(a - c) \tan (90^\circ - \frac{1}{2}B)] \div (a + c)$
<i>Bac</i>	<i>A</i>	$\frac{1}{2}(A + C) + \frac{1}{2}(A - C)$
<i>Bac</i>	<i>C</i>	$\frac{1}{2}(A + C) - \frac{1}{2}(A - C)$
<i>Bac</i>	<i>b</i>	$\sqrt{a^2 + c^2 - 2ac \cos B}$
<i>Cab</i>	$\frac{1}{2}(A + B)$	$90^\circ - \frac{1}{2}C$
<i>Cab</i>	$\frac{1}{2}(A - B)$	$\tan = [(a - b) \tan (90^\circ - \frac{1}{2}C)] \div (a + b)$
<i>Cab</i>	<i>A</i>	$\frac{1}{2}(A + B) + \frac{1}{2}(A - B)$
<i>Cab</i>	<i>B</i>	$\frac{1}{2}(A + B) - \frac{1}{2}(A - B)$
<i>Cab</i>	<i>c</i>	$\sqrt{a^2 + b^2 - 2ab \cos C}$

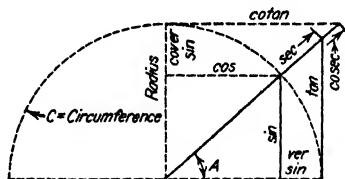
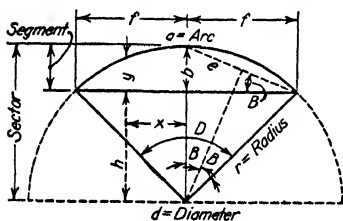

Given	To Find	Formula
<i>drB</i>	<i>b</i>	$d \sin^2 B$
<i>drB</i>	<i>f</i>	$r \sin 2B$
<i>drB</i>	<i>e</i>	$d \sin B$
<i>drb</i>	Ang <i>B</i>	$\sin B = \frac{\sqrt{b + d}}{d}$
<i>drb</i>	<i>f</i>	$\sqrt{b(d - b)}$
<i>drb</i>	<i>e</i>	$\sqrt{db}$
<i>dre</i>	Ang <i>B</i>	$\sin B = \frac{e + d}{d}$
<i>dre</i>	<i>b</i>	$e^2 \div d$
<i>dre</i>	<i>f</i>	$e\sqrt{d^2 - e^2} \div d$
<i>bB</i>	<i>r</i>	$\frac{1}{2}b + \sin^2 B$
<i>eB</i>	<i>r</i>	$\frac{1}{2}e + \sin B$
<i>bf</i>	Ang <i>B</i>	$\tan B = b \div f$

Given	To Find	Formula
$bf$	$r$	$(f^2 + b^2) \div 2b$
$fe$	Ang $B$	$\sin B = \sqrt{e^2 - f^2} \div e$
$fe$	$r$	$\frac{1}{2}e^2 \div \sqrt{e^2 - f^2}$
$be$	Ang $B$	$\sin B = b \div e$
$be$	$r$	$\frac{1}{2}e^2 \div b$
$rx y$	Ang $B$	$\cos 2B = (\sqrt{r^2 - x^2} - y) \div r$
$rx y$	$b$	$r + y - \sqrt{r^2 - x^2}$
$bx$	$y$	$b + \sqrt{r^2 - x^2} - r$
$bry$	$x$	$\sqrt{r^2 - (r + y - b)^2}$
$bry$	$r$	$[x^2 + (b - y)^2] \div (2b - 2y)$
$r$	Circ	$6.2832r$
$rD$	Arc $a$	$.0174533rD^\circ$
$rD$	Arc $a$	$.0002909 rD'$
$rD$	Arc $a$	$.00000485 rD''$
$r$	Area	Circle = $3.1416 r^2$
$d$	Area	Circle = $0.7854 d^2$
$c$	Area	Circle = $0.0796 c^2$
$ar$	Area	Sector = $0.5 ar$
$arfh$	Area	Segment = $0.5 ar - fh$

TABLE 20. NATURAL TRIGONOMETRIC FUNCTIONS \*

Deg.	Min.	Sine	Covers	Cosec	Tan	Cotan	Secant	Versein	Cosine	Deg.	Min.
0	0	0.0000	1.0000	Infinite	0.0000	Infinite	1.0000	0.0000	1.0000	90	0
15		.00436	.99564	229.18	.00436	229.18	1.0000	.00001	.99999		45
30		.00873	.99127	114.59	.00873	114.59	1.0000	.00004	.99996		30
45		.01309	.98691	76.397	.01309	76.390	1.0001	.00009	.99991		15
1	0	.01745	.98255	57.299	.01745	57.290	1.0001	.00015	.99985	89	0
15		.02181	.97819	45.840	.02182	45.829	1.0002	.00024	.99976		45
30		.02618	.97382	38.202	.02618	38.188	1.0003	.00034	.99966		30
45		.03054	.96946	32.746	.03055	32.730	1.0005	.00047	.99953		15
2	0	.03490	.96510	28.654	.03492	28.636	1.0006	.00061	.99939	88	0
15		.03926	.96074	25.471	.03929	25.452	1.0008	.00077	.99923		45
30		.04362	.95638	22.926	.04366	22.904	1.0009	.00095	.99905		30
45		.04798	.95202	20.843	.04803	20.819	1.0011	.00115	.99885		15
3	0	.05234	.94766	18.107	.05241	18.081	1.0014	.00137	.99863	87	0
15		.05669	.94331	17.639	.05678	17.611	1.0016	.00161	.99839		45
30		.06105	.93895	16.380	.06116	16.350	1.0019	.00187	.99813		30
45		.06540	.93460	15.290	.06554	15.257	1.0021	.00214	.99786		15
4	0	.06976	.93024	14.336	.06993	14.301	1.0024	.00244	.99756	86	0
15		.07411	.92589	13.494	.07431	13.457	1.0028	.00275	.99725		45
30		.07846	.92154	12.745	.07870	12.706	1.0031	.00308	.99692		30
45		.08281	.91719	12.076	.08309	12.035	1.0034	.00343	.99656		15
5	0	.08716	.91284	11.474	.08749	11.430	1.0038	.00381	.99619	85	0
15		.09150	.90850	10.929	.09189	10.883	1.0042	.00420	.99580		45
30		.09585	.90415	10.433	.09629	10.385	1.0046	.00466	.99540		30
45		.10019	.89981	9.9812	.10069	9.9310	1.0051	.00503	.99497		15
6	0	.10453	.89547	9.5668	.10510	9.5144	1.0055	.00548	.99452	84	0
15		.10887	.89113	9.1855	.10952	9.1309	1.0060	.00594	.99406		45
30		.11320	.88680	8.8337	.11393	8.7769	1.0065	.00643	.99357		30
45		.11754	.88246	8.5079	.11836	8.4490	1.0070	.00693	.99307		15
7	0	.12187	.87813	8.2055	.12278	8.1443	1.0075	.00745	.99255	83	0
15		.12620	.87380	7.9240	.12722	7.8606	1.0081	.00800	.99200		45
30		.13053	.86947	7.6613	.13165	7.5958	1.0086	.00856	.99144		30
45		.13485	.86515	7.4156	.13609	7.3479	1.0092	.00913	.99086		15
8	0	.13917	.86083	7.1853	.14054	7.1154	1.0098	.00973	.99027	82	0
15		.14349	.85651	6.9690	.14499	6.8969	1.0105	.01035	.98965		45
30		.14781	.85219	6.7655	.14945	6.6912	1.0111	.01098	.98902		30
45		.15212	.84788	6.5736	.15391	6.4971	1.0118	.01164	.98836		15
9	0	.15643	.84357	6.3924	.15838	6.3138	1.0123	.01231	.98769	81	0
15		.16074	.83926	6.2211	.16286	6.1402	1.0132	.01300	.98700		45
30		.16505	.83495	6.0589	.16734	5.9758	1.0139	.01371	.98629		30
45		.16935	.83065	5.9049	.17183	5.8197	1.0147	.01444	.98556		15
10	0	.17365	.82635	5.7588	.17633	5.6713	1.0154	.01519	.98481	80	0
15		.17794	.82206	5.6198	.18083	5.5301	1.0162	.01596	.98404		45
30		.18224	.81776	5.4874	.18534	5.3955	1.0170	.01675	.98325		30
45		.18652	.81348	5.3612	.18986	5.2672	1.0179	.01755	.98245		15
11	0	.19081	.80919	5.2408	.19438	5.1446	1.0187	.01837	.98163	79	0
15		.19509	.80491	5.1258	.19891	5.0273	1.0196	.01921	.98079		45
30		.19937	.80063	5.0158	.20345	4.9152	1.0205	.02008	.97992		30
45		.20364	.79636	4.9106	.20800	4.8077	1.0214	.02095	.97905		15
12	0	.20791	.79209	4.8097	.21256	4.7046	1.0223	.02185	.97815	78	0
15		.21218	.78782	4.7130	.21712	4.6057	1.0233	.02277	.97723		45
30		.21644	.78356	4.6202	.22169	4.5107	1.0243	.02370	.97630		30
45		.22070	.77930	4.5311	.22628	4.4194	1.0253	.02466	.97534		15
13	0	.22495	.77505	4.4454	.23087	4.3315	1.0263	.02563	.97437	77	0
15		.22920	.77080	4.3630	.23547	4.2468	1.0273	.02662	.97338		45
30		.23345	.76655	4.2837	.24008	4.1653	1.0284	.02763	.97237		30
45		.23769	.76231	4.2072	.24470	4.0867	1.0295	.02866	.97134		15
14	0	.24192	.75808	4.1336	.24933	4.0108	1.0306	.02970	.97030	76	0
15		.24615	.75385	4.0625	.25397	3.9375	1.0317	.03077	.96923		45
30		.25038	.74962	3.9939	.25862	3.8667	1.0329	.03185	.96815		30
45		.25460	.74540	3.9277	.26328	3.7983	1.0341	.03295	.96705		15
15	0	.25882	.74118	3.8637	.26795	3.7320	1.0353	.03407	.96593	75	0

From 75° to 90° read from bottom of table upwards.

\* From Pelee, Mining Engineers' Handbook, John Wiley & Sons.

TABLE 20. NATURAL TRIGONOMETRIC FUNCTIONS—Continued

Deg.	Min.	Sine	Covers	Cosec	Tan	Cotan	Secant	Versin	Cosine	Deg.	Min.
16	0	0.26882	0.74118	3.8637	0.26795	3.7320	1.0853	0.03407	0.96593	75	0
	15	.26303	.73697	3.8018	.27263	3.6680	1.0365	.03521	.96479		45
	30	.26724	.73276	3.7420	.27732	3.6059	1.0377	.03637	.96363		30
	45	.27144	.72856	3.6840	.28203	3.5457	1.0390	.03754	.96246		15
16	0	0.27564	0.72436	3.6280	0.28674	3.4874	1.0403	0.03874	0.96126	74	0
	15	.27983	.72017	3.5736	.29147	3.4308	1.0416	.03995	.96005		45
	30	.28402	.71598	3.5209	.29621	3.3759	1.0429	.04118	.95882		30
	45	.28820	.71180	3.4699	.30096	3.3226	1.0443	.04243	.95757		15
17	0	0.29237	0.70763	3.4203	0.30573	3.2709	1.0457	0.04370	0.95630	73	0
	15	.29654	.70346	3.3722	.31051	3.2205	1.0471	.04498	.95502		45
	30	.30070	.69929	3.3255	.31530	3.1716	1.0485	.04628	.95372		30
	45	.30486	.69514	3.2801	.32019	3.1240	1.0500	.04760	.95240		15
18	0	0.30902	0.69098	3.2361	0.32492	3.0777	1.0515	0.04894	0.95106	72	0
	15	.31316	.68684	3.1932	.32975	3.0326	1.0530	.05030	.94970		45
	30	.31730	.68270	3.1515	.33459	2.9887	1.0545	.05168	.94832		30
	45	.32144	.67856	3.1110	.33945	2.9459	1.0560	.05307	.94693		15
19	0	0.32557	0.67443	3.0715	0.34433	2.9042	1.0576	0.05448	0.94552	71	0
	15	.32969	.67031	3.0331	.34921	2.8636	1.0592	.05591	.94409		45
	30	.33381	.66619	2.9957	.35412	2.8239	1.0608	.05736	.94264		30
	45	.33792	.66208	2.9593	.35904	2.7852	1.0625	.05882	.94118		15
20	0	0.34202	0.65798	2.9238	0.36397	2.7475	1.0642	0.06031	0.93969	70	0
	15	.34612	.65388	2.8892	.36892	2.7106	1.0659	.06181	.93819		45
	30	.35021	.64979	2.8554	.37388	2.6746	1.0676	.06333	.93667		30
	45	.35429	.64571	2.8225	.37887	2.6395	1.0694	.06486	.93514		15
21	0	0.35837	0.64163	2.7904	0.38388	2.6051	1.0711	0.06642	0.93358	69	0
	15	.36244	.63756	2.7591	.38888	2.5715	1.0729	.06799	.93201		45
	30	.36650	.63350	2.7285	.39391	2.5386	1.0748	.06958	.93042		30
	45	.37056	.62944	2.6986	.39896	2.5065	1.0766	.07119	.92881		15
22	0	0.37461	0.62559	2.6695	0.40403	2.4751	1.0785	0.07282	0.92718	68	0
	15	.37865	.62155	2.6410	.40911	2.4443	1.0804	.07446	.92554		45
	30	.38268	.61752	2.6131	.41421	2.4142	1.0824	.07612	.92388		30
	45	.38671	.61350	2.5859	.41933	2.3847	1.0844	.07780	.92220		15
23	0	0.39073	0.60927	2.5593	0.42447	2.3559	1.0864	0.07950	0.92050	67	0
	15	.39474	.60526	2.5333	.42963	2.3276	1.0884	.08121	.91879		45
	30	.39875	.60125	2.5078	.43481	2.2998	1.0904	.08294	.91706		30
	45	.40275	.59725	2.4829	.44001	2.2727	1.0925	.08469	.91531		15
24	0	0.40674	0.59326	2.4586	0.44523	2.2460	1.0946	0.08645	0.91355	66	0
	15	.41072	.58928	2.4348	.45047	2.2199	1.0968	.08824	.91176		45
	30	.41469	.58531	2.4114	.45573	2.1943	1.0989	.09004	.90996		30
	45	.41866	.58134	2.3886	.46101	2.1692	1.1011	.09186	.90814		15
25	0	0.42262	0.57738	2.3662	0.46631	2.1445	1.1034	0.09369	0.90631	65	0
	15	.42657	.57343	2.3443	.47163	2.1203	1.1056	.09554	.90446		45
	30	.43051	.56949	2.3228	.47697	2.0965	1.1079	.09741	.90259		30
	45	.43445	.56555	2.3018	.48234	2.0732	1.1102	.09930	.90070		15
26	0	0.43837	0.56163	2.2812	0.48773	2.0503	1.1126	0.10121	0.89879	64	0
	15	.44229	.55771	2.2610	.49314	2.0278	1.1150	.10313	.89687		45
	30	.44620	.55380	2.2412	.49858	2.0057	1.1174	.10507	.89493		30
	45	.45010	.54990	2.2217	.50404	1.9840	1.1198	.10702	.89298		15
27	0	0.45399	0.54601	2.2027	0.50952	1.9626	1.1223	0.10899	0.89101	63	0
	15	.45787	.54213	2.1840	.51503	1.9416	1.1248	.11098	.88902		45
	30	.46175	.53825	2.1657	.52057	1.9210	1.1274	.11299	.88701		30
	45	.46561	.53439	2.1477	.52612	1.9007	1.1300	.11501	.88499		15
28	0	0.46947	0.53053	2.1300	0.53171	1.8807	1.1326	0.11705	0.88295	62	0
	15	.47332	.52668	2.1127	.53732	1.8611	1.1352	.11911	.88089		45
	30	.47716	.52284	2.0957	.54295	1.8418	1.1379	.12118	.87882		30
	45	.48099	.51901	2.0790	.54862	1.8228	1.1406	.12327	.87673		15
29	0	0.48481	0.51519	2.0627	0.55431	1.8040	1.1433	0.12538	0.87462	61	0
	15	.48862	.51138	2.0466	.56003	1.7856	1.1461	.12750	.87250		45
	30	.49242	.50758	2.0308	.56577	1.7675	1.1490	.12964	.87036		30
	45	.49622	.50378	2.0152	.57155	1.7496	1.1518	.13180	.86820		15
30	0	0.50000	0.50000	2.0000	0.57735	1.7320	1.1547	0.13397	0.86603	60	0
		Cosine	Versin	Secant	Cotan	Tan	Cosec	Covers	Sine	Deg.	Min.

From 60° to 75° read from bottom of table upwards.

TABLE 20. NATURAL TRIGONOMETRIC FUNCTIONS—*Concluded*

Deg.	Min.	Sine	Covers	Cosec	Tan	Cotan	Secant	Versin	Cosine		
20	0	0.80000	0.80000	2.0000	0.87735	1.7320	1.1547	0.13397	0.86603	80	0
	15	.50377	.49623	1.9850	.58318	1.7147	1.1576	.13616	.86384		45
	30	.50754	.49246	1.9703	.58904	1.6977	1.1606	.13837	.86163		30
	45	.51129	.48871	1.9558	.59494	1.6808	1.1636	.14059	.85941		15
31	0	0.81604	.48496	1.8416	.60086	1.6643	1.1666	.14283	.85717	59	0
	15	.51877	.48123	1.9276	.60681	1.6479	1.1697	.14509	.85491		45
	30	.52250	.47750	1.9139	.61280	1.6319	1.1728	.14736	.85264		30
	45	.52621	.47379	1.9004	.61882	1.6160	1.1760	.14965	.85035		15
33	0	0.82992	.47008	1.8871	.63487	1.6003	1.1792	.15195	.84808	58	0
	15	.53361	.46639	1.8740	.63095	1.5849	1.1824	.15427	.84573		45
	30	.53730	.46270	1.8612	.63707	1.5697	1.1857	.15661	.84339		30
	45	.54097	.45903	1.8485	.64322	1.5547	1.1890	.15896	.84104		15
33	0	0.84464	.46536	1.8861	.64941	1.5399	1.1924	.16133	.83867	57	0
	15	.54829	.45171	1.8238	.65563	1.5253	1.1958	.16371	.83629		45
	30	.55194	.44806	1.8118	.66188	1.5108	1.1992	.16611	.83389		30
	45	.55557	.44443	1.7999	.66818	1.4966	1.2027	.16853	.83147		15
34	0	0.85919	.44081	1.7883	.67451	1.4826	1.2062	.17096	.82904	56	0
	15	.56280	.43720	1.7768	.68087	1.4687	1.2098	.17341	.82659		45
	30	.56641	.43359	1.7655	.68728	1.4550	1.2134	.17587	.82413		30
	45	.57000	.43000	1.7544	.69372	1.4415	1.2171	.17835	.82165		15
35	0	0.87358	.42642	1.7434	.70021	1.4281	1.2208	.18085	.81915	55	0
	15	.57715	.42285	1.7327	.70673	1.4150	1.2245	.18336	.81664		45
	30	.58070	.41930	1.7220	.71329	1.4019	1.2283	.18588	.81412		30
	45	.58425	.41575	1.7116	.71990	1.3891	1.2322	.18843	.81157		15
36	0	0.88779	.41221	1.7013	.72654	1.3764	1.2361	.19098	.80902	54	0
	15	.59131	.40869	1.6912	.73323	1.3638	1.2400	.19356	.80644		45
	30	.59482	.40518	1.6812	.73996	1.3514	1.2440	.19614	.80386		30
	45	.59832	.40168	1.6713	.74673	1.3392	1.2480	.19875	.80125		15
37	0	0.90181	.39819	1.6616	.75355	1.3270	1.2521	.20136	.79864	53	0
	15	.60529	.39471	1.6521	.76042	1.3151	1.2563	.20400	.79600		45
	30	.60876	.39124	1.6427	.76733	1.3032	1.2605	.20665	.79335		30
	45	.61222	.38778	1.6334	.77428	1.2915	1.2647	.20931	.79069		15
38	0	0.91566	.38434	1.6243	.78129	1.2799	1.2690	.21199	.78801	52	0
	15	.61909	.38091	1.6153	.78834	1.2685	1.2734	.21468	.78532		45
	30	.62251	.37749	1.6064	.79543	1.2572	1.2778	.21739	.78261		30
	45	.62592	.37408	1.5976	.80258	1.2460	1.2822	.22012	.77988		15
39	0	0.92932	.37068	1.5890	.80978	1.2349	1.2865	.22285	.77715	51	0
	15	.63271	.36729	1.5805	.81703	1.2239	1.2913	.22561	.77439		45
	30	.63608	.36392	1.5721	.82434	1.2131	1.2960	.22838	.77162		30
	45	.63944	.36056	1.5639	.83169	1.2024	1.3007	.23116	.76884		15
40	0	0.94279	.35721	1.5557	.83910	1.1918	1.3054	.23396	.76604	50	0
	15	.64612	.35388	1.5477	.84656	1.1812	1.3102	.23677	.76323		45
	30	.64945	.35055	1.5398	.85408	1.1708	1.3151	.23959	.76041		30
	45	.65276	.34724	1.5320	.86165	1.1606	1.3200	.24244	.75756		15
41	0	0.95606	.34394	1.5242	.86929	1.1504	1.3250	.24529	.75471	49	0
	15	.65935	.34065	1.5166	.87698	1.1403	1.3301	.24816	.75184		45
	30	.66262	.33738	1.5092	.88472	1.1303	1.3352	.25104	.74896		30
	45	.66588	.33412	1.5018	.89253	1.1204	1.3404	.25394	.74606		15
42	0	0.96918	.33087	1.4945	.90040	1.1106	1.3456	.25686	.74314	48	0
	15	.67237	.32763	1.4873	.90834	1.1009	1.3509	.25978	.74022		45
	30	.67559	.32441	1.4802	.91633	1.0913	1.3563	.26272	.73728		30
	45	.67880	.32120	1.4732	.92439	1.0818	1.3618	.26568	.73432		15
43	0	0.98200	.31800	1.4663	.93251	1.0724	1.3673	.26865	.73135	47	0
	15	.68518	.31482	1.4595	.94071	1.0630	1.3729	.27163	.72837		45
	30	.68835	.31165	1.4527	.94896	1.0538	1.3786	.27463	.72537		30
	45	.69151	.30849	1.4461	.95729	1.0446	1.3843	.27764	.72236		15
44	0	0.99466	.30534	1.4395	.96569	1.0355	1.3902	.28066	.71934	46	0
	15	.69779	.30221	1.4331	.97416	1.0265	1.3961	.28370	.71630		45
	30	.70091	.29909	1.4267	.98270	1.0176	1.4020	.28675	.71325		30
	45	.70401	.29599	1.4204	.99131	1.0088	1.4081	.28981	.71019		15
45	0	.70711	.29289	1.4143	1.0000	1.0000	1.4143	.29289	.70711	45	0

From 45° to 60° read from bottom of table upwards.

TABLE 21. LOGARITHMIC TRIGONOMETRIC FUNCTIONS \*

Deg.	Sine	Cosec	Versin	Tangent	Cotan	Covers	Secant	Cosine	Deg
0	—	+∞	—	—	+∞	10. 00000	10. 00000	10. 00000	90
1	8. 24186	11. 75814	6. 18271	8. 24192	11. 75808	9. 99235	10. 00007	9. 99993	89
2	8. 54282	11. 45718	6. 78474	8. 54308	11. 45692	9. 98457	10. 00026	9. 99974	88
3	8. 71880	11. 28120	7. 13687	8. 71940	11. 28060	9. 97665	10. 00060	9. 99940	87
4	8. 84358	11. 15642	7. 38667	8. 84464	11. 15536	9. 96860	10. 00106	9. 99894	86
5	8. 94030	11. 05970	7. 58039	8. 94195	11. 05805	9. 96040	10. 00166	9. 99834	85
6	9. 01923	10. 98077	7. 73863	9. 02162	10. 97838	9. 95205	10. 00239	9. 99761	84
7	9. 08589	10. 91411	7. 87238	9. 08914	10. 91086	9. 94356	10. 00325	9. 99675	83
8	9. 14356	10. 85644	7. 98820	9. 14780	10. 85220	9. 93492	10. 00425	9. 99575	82
9	9. 19433	10. 80567	8. 09032	9. 19971	10. 80029	9. 92612	10. 00538	9. 99462	81
10	9. 23967	10. 76033	8. 18162	9. 24632	10. 75368	9. 91717	10. 00665	9. 99335	80
11	9. 28060	10. 71940	8. 26418	9. 28665	10. 71135	9. 90805	10. 00805	9. 99195	79
12	9. 31788	10. 68212	8. 33950	9. 32747	10. 67253	9. 89877	10. 00960	9. 99040	78
13	9. 35209	10. 64791	8. 40875	9. 36336	10. 63664	9. 88933	10. 01128	9. 98872	77
14	9. 38568	10. 61632	8. 47282	9. 39677	10. 60323	9. 87971	10. 01310	9. 98690	76
15	9. 41300	10. 58700	8. 53243	9. 42805	10. 57195	9. 86992	10. 01506	9. 98494	75
16	9. 44034	10. 55966	8. 58814	9. 45750	10. 54250	9. 85996	10. 01716	9. 98284	74
17	9. 46594	10. 53406	8. 64043	9. 48534	10. 51466	9. 84981	10. 01940	9. 98060	73
18	9. 48998	10. 51002	8. 68969	9. 51178	10. 48822	9. 83947	10. 02179	9. 97821	72
19	9. 51264	10. 48736	8. 73625	9. 53697	10. 46303	9. 82894	10. 02433	9. 97567	71
20	9. 53405	10. 46595	8. 78037	9. 56107	10. 43893	9. 81821	10. 02701	9. 97299	70
21	9. 55433	10. 44567	8. 82230	9. 58418	10. 41582	9. 80729	10. 02985	9. 97015	69
22	9. 57358	10. 42642	8. 86223	9. 60641	10. 39359	9. 79615	10. 03283	9. 96717	68
23	9. 59188	10. 40812	8. 90034	9. 62785	10. 37215	9. 78481	10. 03597	9. 96403	67
24	9. 60931	10. 39069	8. 93679	9. 64858	10. 35142	9. 77325	10. 03927	9. 96073	66
25	9. 62595	10. 37405	8. 97170	9. 66867	10. 33133	9. 76146	10. 04272	9. 95728	65
26	9. 64184	10. 35816	9. 00521	9. 68818	10. 31182	9. 74945	10. 04634	9. 95366	64
27	9. 65705	10. 34295	9. 03740	9. 70717	10. 29283	9. 73720	10. 05012	9. 94988	63
28	9. 67161	10. 32839	9. 06838	9. 72567	10. 27433	9. 72471	10. 05407	9. 94593	62
29	9. 68557	10. 31443	9. 09823	9. 74375	10. 25625	9. 71197	10. 05818	9. 94182	61
30	9. 69897	10. 30103	9. 12702	9. 76144	10. 23856	9. 69897	10. 06247	9. 93753	60
31	9. 71184	10. 28816	9. 15483	9. 77877	10. 22123	9. 68571	10. 06693	9. 93307	59
32	9. 72421	10. 27579	9. 18171	9. 79579	10. 20421	9. 67217	10. 07158	9. 92842	58
33	9. 73611	10. 26389	9. 20771	9. 81252	10. 18748	9. 65836	10. 07641	9. 92359	57
34	9. 74756	10. 25244	9. 23290	9. 82899	10. 17101	9. 64425	10. 08143	9. 91857	56
35	9. 75859	10. 24141	9. 25731	9. 84523	10. 15477	9. 62984	10. 08664	9. 91336	55
36	9. 76922	10. 23078	9. 28099	9. 86126	10. 13874	9. 61512	10. 09204	9. 90796	54
37	9. 77946	10. 22054	9. 30398	9. 87711	10. 12289	9. 60008	10. 09765	9. 90235	53
38	9. 78934	10. 21066	9. 32631	9. 89281	10. 10719	9. 58471	10. 10347	9. 89653	52
39	9. 79887	10. 20113	9. 34802	9. 90837	10. 09163	9. 56900	10. 10950	9. 89050	51
40	9. 80807	10. 19193	9. 36913	9. 92381	10. 07619	9. 55293	10. 11575	9. 88425	50
41	9. 81694	10. 18306	9. 38968	9. 93916	10. 06084	9. 53648	10. 12222	9. 87778	49
42	9. 82551	10. 17449	9. 40969	9. 95444	10. 04556	9. 51966	10. 12893	9. 87107	48
43	9. 83378	10. 16622	9. 42918	9. 96966	10. 03034	9. 50243	10. 13587	9. 86413	47
44	9. 84177	10. 15823	9. 44818	9. 98484	10. 01516	9. 48479	10. 14307	9. 85693	46
45	9. 84949	10. 15052	9. 46671	10. 00000	10. 00000	9. 46671	10. 15052	9. 84949	45
	Cosine	Secant	Covers	Cotan	Tangent	Versin	Cosec	Sine	

From 45° to 90° read from bottom of table upwards.

\* From Kent, *Mechanical Engineers' Handbook, Power Volume, John Wiley & Sons.*

TABLE 22. MINUTES INTO DECIMALS OF A DEGREE \*

'	0°	10°	15°	20°	30°	40°	45°	50°	'
0	.00000	.00278	.00417	.00556	.00833	.01111	.01250	.01389	0
1	.01667	.01944	.02083	.02222	.02500	.02778	.02917	.03056	1
2	.03333	.03611	.03750	.03889	.04167	.04444	.04583	.04722	2
3	.05000	.05278	.05417	.05556	.05833	.06111	.06250	.06389	3
4	.06667	.06944	.07083	.07222	.07500	.07778	.07917	.08056	4
5	.08333	.08611	.08750	.08889	.09167	.09444	.09583	.09722	5
6	.10000	.10278	.10417	.10556	.10833	.11111	.11250	.11389	6
7	.11667	.11944	.12083	.12222	.12500	.12778	.12917	.13056	7
8	.13333	.13611	.13750	.13889	.14167	.14444	.14583	.14722	8
9	.15000	.15278	.15417	.15556	.15833	.16111	.16250	.16389	9
10	.16667	.16944	.17083	.17222	.17500	.17778	.17917	.18056	10
11	.18333	.18611	.18750	.18889	.19167	.19444	.19583	.19722	11
12	.20000	.20278	.20417	.20556	.20833	.21111	.21250	.21389	12
13	.21667	.21944	.22083	.22222	.22500	.22778	.22917	.23056	13
14	.23333	.23611	.23750	.23889	.24167	.24444	.24583	.24722	14
15	.25000	.25278	.25417	.25556	.25833	.26111	.26250	.26389	15
16	.26667	.26944	.27083	.27222	.27500	.27778	.27917	.28056	16
17	.28333	.28611	.28750	.28889	.29167	.29444	.29583	.29722	17
18	.30000	.30278	.30417	.30556	.30833	.31111	.31250	.31389	18
19	.31667	.31944	.32083	.32222	.32500	.32778	.32917	.33056	19
20	.33333	.33611	.33750	.33889	.34167	.34444	.34583	.34722	20
21	.35000	.35278	.35417	.35556	.35833	.36111	.36250	.36389	21
22	.36667	.36944	.37083	.37222	.37500	.37778	.37917	.38056	22
23	.38333	.38611	.38750	.38889	.39167	.39444	.39583	.39722	23
24	.40000	.40278	.40417	.40556	.40833	.41111	.41250	.41389	24
25	.41667	.41944	.42083	.42222	.42500	.42778	.42917	.43056	25
26	.43333	.43611	.43750	.43889	.44167	.44444	.44583	.44722	26
27	.45000	.45278	.45417	.45556	.45833	.46111	.46250	.46389	27
28	.46667	.46944	.47083	.47222	.47500	.47778	.47917	.48056	28
29	.48333	.48611	.48750	.48889	.49167	.49444	.49583	.49722	29
30	.50000	.50278	.50417	.50556	.50833	.51111	.51250	.51389	30
31	.51667	.51944	.52083	.52222	.52500	.52778	.52917	.53056	31
32	.53333	.53611	.53750	.53889	.54167	.54444	.54583	.54722	32
33	.55000	.55278	.55417	.55556	.55833	.56111	.56250	.56389	33
34	.56667	.56944	.57083	.57222	.57500	.57778	.57917	.58056	34
35	.58333	.58611	.58750	.58889	.59167	.59444	.59583	.59722	35
36	.60000	.60278	.60417	.60556	.60833	.61111	.61250	.61389	36
37	.61667	.61944	.62083	.62222	.62500	.62778	.62917	.63056	37
38	.63333	.63611	.63750	.63889	.64167	.64444	.64583	.64722	38
39	.65000	.65278	.65417	.65556	.65833	.66111	.66250	.66389	39
40	.66667	.66944	.67083	.67222	.67500	.67778	.67917	.68056	40
41	.68333	.68611	.68750	.68889	.69167	.69444	.69583	.69722	41
42	.70000	.70278	.70417	.70556	.70833	.71111	.71250	.71389	42
43	.71667	.71944	.72083	.72222	.72500	.72778	.72917	.73056	43
44	.73333	.73611	.73750	.73889	.74167	.74444	.74583	.74722	44
45	.75000	.75278	.75417	.75556	.75833	.76111	.76250	.76389	45
46	.76667	.76944	.77083	.77222	.77500	.77778	.77917	.78056	46
47	.78333	.78611	.78750	.78889	.79167	.79444	.79583	.79722	47
48	.80000	.80278	.80417	.80556	.80833	.81111	.81250	.81389	48
49	.81667	.81944	.82083	.82222	.82500	.82778	.82917	.83056	49
50	.83333	.83611	.83750	.83889	.84167	.84444	.84583	.84722	50
51	.85000	.85278	.85417	.85556	.85833	.86111	.86250	.86389	51
52	.86667	.86944	.87083	.87222	.87500	.87778	.87917	.88056	52
53	.88333	.88611	.88750	.88889	.89167	.89444	.89583	.89722	53
54	.90000	.90278	.90417	.90556	.90833	.91111	.91250	.91389	54
55	.91667	.91944	.92083	.92222	.92500	.92778	.92917	.93056	55
56	.93333	.93611	.93750	.93889	.94167	.94444	.94583	.94722	56
57	.95000	.95278	.95417	.95556	.95833	.96111	.96250	.96389	57
58	.96667	.96944	.97083	.97222	.97500	.97778	.97917	.98056	58
59	.98333	.98611	.98750	.98889	.99167	.99444	.99583	.99722	59

\* From Ives, *Seven Place Natural Trigonometric Functions*, John Wiley & Sons.



**TABLE 23. LOGARITHMS OF NUMBERS \***

n	0	1	2	3	4	5	6	7	8	9
10	00000	00432	00860	01284	01703	02119	02531	02938	03342	03743
11	04139	04532	04922	05308	05690	06070	06446	06819	07188	07555
12	07918	08279	08636	08991	09342	09691	10037	10380	10721	11059
13	11394	11727	12057	12385	12710	13033	13354	13672	13988	14301
14	14613	14922	15229	15534	15836	16137	16435	16732	17026	17319
15	17609	17898	18184	18469	18752	19033	19312	19590	19866	20140
16	20412	20683	20952	21219	21484	21748	22011	22272	22531	22789
17	23045	23300	23553	23805	24055	24304	24551	24797	25042	25285
18	25527	25768	26007	26245	26482	26717	26951	27184	27416	27646
19	27875	28103	28330	28556	28780	29003	29226	29447	29667	29885
20	30103	30320	30535	30750	30963	31175	31387	31597	31806	32015
21	32222	32428	32634	32838	33041	33244	33445	33646	33846	34044
22	34242	34439	34635	34830	35025	35218	35411	35603	35793	35984
23	36173	36361	36549	36736	36922	37107	37291	37475	37658	37840
24	38021	38202	38382	38561	38739	38917	39094	39270	39445	39620
25	39794	39967	40140	40312	40483	40654	40824	40993	41162	41330
26	41497	41664	41830	41996	42160	42325	42488	42651	42813	42975
27	43136	43297	43457	43616	43775	43933	44091	44248	44404	44560
28	44716	44871	45025	45179	45332	45484	45637	45788	45939	46090
29	46240	46389	46538	46687	46835	46982	47129	47276	47422	47567
30	47712	47857	48001	48144	48287	48430	48572	48714	48855	48996
31	49136	49276	49415	49554	49693	49831	49969	50106	50243	50379
32	50515	50651	50786	50920	51055	51188	51322	51455	51587	51720
33	51851	51983	52114	52244	52375	52504	52634	52763	52892	53020
34	53148	53275	53403	53529	53656	53782	53908	54033	54158	54283
35	54407	54531	54654	54777	54900	55023	55145	55267	55388	55509
36	55630	55751	55871	55991	56110	56229	56348	56467	56585	56703
37	56820	56937	57054	57171	57287	57403	57519	57634	57749	57864
38	57978	58092	58206	58320	58433	58546	58659	58771	58883	58995
39	59106	59218	59329	59439	59550	59660	59770	59879	59988	60097
40	60206	60314	60423	60531	60638	60746	60853	60959	61066	61172
41	61278	61384	61490	61595	61700	61805	61909	62014	62118	62221
42	62325	62428	62531	62634	62737	62839	62941	63043	63144	63246
43	63347	63448	63548	63649	63749	63849	63949	64048	64147	64246
44	64345	64444	64542	64640	64738	64836	64933	65031	65128	65225
45	65321	65418	65514	65610	65706	65801	65896	65992	66087	66181
46	66276	66370	66464	66558	66652	66745	66839	66932	67025	67117
47	67210	67302	67394	67486	67578	67669	67761	67852	67943	68034
48	68124	68215	68305	68395	68485	68574	68664	68753	68842	68931
49	69020	69108	69197	69285	69373	69461	69548	69636	69723	69810
50	69897	69984	70070	70157	70243	70329	70415	70501	70586	70672
51	70757	70842	70927	71012	71096	71181	71265	71349	71433	71517
52	71600	71684	71767	71850	71933	72016	72099	72181	72263	72346
53	72428	72509	72591	72673	72754	72835	72916	72997	73078	73159
54	73239	73320	73400	73480	73560	73640	73719	73799	73878	73957

\* From American Civil Engineers' Handbook by Merriam and Wiggin, John Wiley & Sons.

TABLE 23. LOGARITHMS OF NUMBERS (Continued)

n	0	1	2	3	4	5	6	7	8	9
55	74036	74115	74194	74273	74351	74429	74507	74586	74663	74741
56	74819	74896	74974	75051	75128	75205	75282	75358	75435	75511
57	75587	75664	75740	75815	75891	75967	76042	76118	76193	76268
58	76343	76418	76492	76567	76641	76716	76790	76864	76938	77012
59	77085	77159	77232	77305	77379	77452	77525	77597	77670	77743
60	77815	77887	77960	78032	78104	78176	78247	78319	78390	78462
61	78533	78604	78675	78746	78817	78888	78958	79029	79099	79169
62	79239	79309	79379	79449	79518	79588	79657	79727	79796	79865
63	79934	80003	80072	80140	80209	80277	80346	80414	80482	80550
64	80618	80686	80754	80821	80889	80956	81023	81090	81158	81224
65	81291	81358	81425	81491	81558	81624	81690	81757	81823	81889
66	81954	82020	82086	82151	82217	82282	82347	82413	82478	82543
67	82607	82672	82737	82802	82866	82930	82995	83059	83123	83187
68	83251	83315	83378	83442	83506	83569	83632	83696	83759	83822
69	83885	83948	84011	84073	84136	84198	84261	84323	84386	84448
70	84510	84572	84634	84696	84757	84819	84880	84942	85003	85065
71	85126	85187	85248	85309	85370	85431	85491	85552	85612	85673
72	85733	85794	85854	85914	85974	86034	86094	86153	86213	86273
73	86332	86392	86451	86510	86570	86629	86688	86747	86806	86864
74	86923	86982	87040	87099	87157	87216	87274	87332	87390	87448
75	87506	87564	87622	87679	87737	87795	87852	87910	87967	88024
76	88081	88138	88195	88252	88309	88366	88423	88480	88536	88593
77	88649	88705	88762	88818	88874	88930	88986	89042	89098	89154
78	89209	89265	89321	89376	89432	89487	89542	89597	89653	89708
79	89763	89818	89873	89927	89982	90037	90091	90146	90200	90255
80	90309	90363	90417	90472	90526	90580	90634	90687	90741	90795
81	90849	90902	90956	91009	91062	91116	91169	91222	91275	91328
82	91381	91434	91487	91540	91593	91645	91698	91751	91803	91855
83	91908	91960	92012	92065	92117	92169	92221	92273	92324	92376
84	92428	92480	92531	92583	92634	92686	92737	92788	92840	92891
85	92942	92993	93044	93095	93146	93197	93247	93298	93349	93399
86	93450	93500	93551	93601	93651	93702	93752	93802	93852	93902
87	93952	94002	94052	94101	94151	94201	94250	94300	94349	94399
88	94448	94498	94547	94596	94645	94694	94743	94792	94841	94890
89	94939	94988	95036	95085	95134	95182	95231	95279	95328	95376
90	95424	95472	95521	95569	95617	95665	95713	95761	95809	95856
91	95904	95952	95999	96047	96095	96142	96190	96237	96284	96332
92	96379	96426	96473	96520	96567	96614	96661	96708	96755	96802
93	96848	96895	96942	96988	97035	97081	97128	97174	97220	97267
94	97313	97359	97405	97451	97497	97543	97589	97635	97681	97727
95	97772	97818	97864	97909	97955	98000	98046	98091	98137	98182
96	98227	98272	98318	98363	98408	98453	98498	98543	98588	98632
97	98677	98722	98767	98811	98856	98900	98945	98989	99034	99078
98	99123	99167	99211	99255	99300	99344	99388	99432	99476	99520
99	99564	99607	99651	99695	99739	99782	99826	99870	99913	99957

**TABLE 24. DECIMAL EQUIVALENTS OF COMMON FRACTIONS \***

The given decimals are the parts of inches corresponding to fraction of inches in first column; also, the parts of feet for the fraction of inches in third column.

	0.0052	1/16		0.2552	3 1/16		0.5052	6 1/16		0.7552	9 1/16
	0.0104	1/8		0.2604	3 1/8		0.5104	6 1/8		0.7604	9 1/8
1/64	0.015625	3/16	17/64	0.265625	3 3/16	33/64	0.515625	6 3/16	49/64	0.765625	9 3/16
	0.0208	1/4		0.2708	3 1/4		0.5208	6 1/4		0.7708	9 1/4
	0.0260	5/16		0.2760	3 5/16		0.5260	6 5/16		0.7760	9 5/16
1/32	0.03125	3/8	9/32	0.28125	3 3/8	17/32	0.53125	6 3/8	25/32	0.78125	9 3/8
	0.0364	7/16		0.2865	3 7/16		0.5364	6 7/16		0.7865	9 7/16
	0.0417	1/2		0.2917	3 1/2		0.5417	6 1/2		0.7917	9 1/2
3/64	0.046875	9/16	19/64	0.296875	3 9/16	35/64	0.546875	6 9/16	51/64	0.796875	9 9/16
	0.0521	5/8		0.3021	3 5/8		0.5521	6 5/8		0.8021	9 5/8
	0.0573	11/16		0.3073	3 11/16		0.5573	6 11/16		0.8073	9 11/16
1/16	0.0625	3/4	5/16	0.3125	3 3/4	9/16	0.5625	6 3/4	13/16	0.8125	9 3/4
	0.0677	13/16		0.3177	3 13/16		0.5677	6 13/16		0.8177	9 13/16
	0.0729	7/8		0.3229	3 7/8		0.5729	6 7/8		0.8229	9 7/8
5/64	0.078125	15/16	21/64	0.328125	3 15/16	37/64	0.578125	6 15/16	53/64	0.828125	9 15/16
	0.0833	1		0.3333	4		0.5833	7		0.8333	10
	0.0885	1 1/16		0.3385	4 1/16		0.5885	7 1/16		0.8385	10 1/16
3/32	0.09375	1 1/8	11/32	0.34375	4 1/8	19/32	0.59375	7 1/8	27/32	0.84375	10 1/8
	0.0990	1 3/16		0.3490	4 3/16		0.5990	7 3/16		0.8490	10 3/16
	0.1042	1 1/4		0.3542	4 1/4		0.6042	7 1/4		0.8542	10 1/4
7/64	0.109375	1 5/16	23/64	0.359375	4 5/16	39/64	0.609375	7 5/16	55/64	0.859375	10 5/16
	0.1146	1 3/8		0.3646	4 3/8		0.6146	7 3/8		0.8646	10 3/8
	0.1198	1 7/16		0.3698	4 7/16		0.6198	7 7/16		0.8698	10 7/16
1/8	0.1250	1 1/2	3/8	0.3750	4 1/2	5/8	0.6250	7 1/2	7/8	0.8750	10 1/2
	0.1302	1 9/16		0.3802	4 9/16		0.6302	7 9/16		0.8802	10 9/16
	0.1354	1 5/8		0.3854	4 5/8		0.6354	7 5/8		0.8854	10 5/8
9/64	0.140625	1 11/16	25/64	0.390625	4 11/16	41/64	0.640625	7 11/16	57/64	0.890625	10 11/16
	0.1458	1 3/4		0.3958	4 3/4		0.6458	7 3/4		0.8958	10 3/4
	0.1510	1 13/16		0.4010	4 13/16		0.6510	7 13/16		0.9010	10 13/16
5/32	0.15625	1 7/8	13/32	0.40625	4 7/8	21/32	0.65625	7 7/8	29/32	0.90625	10 7/8
	0.1615	1 15/16		0.4114	4 15/16		0.6615	7 15/16		0.9115	10 15/16
	0.1667	2		0.4167	5		0.6667	8		0.9167	11
11/64	0.171875	2 1/16	27/64	0.421875	5 1/16	43/64	0.671875	8 1/16	59/64	0.921875	11 1/16
	0.1771	2 1/8		0.4271	5 1/8		0.6771	8 1/8		0.9271	11 1/8
	0.1823	2 3/16		0.4323	5 3/16		0.6823	8 3/16		0.9323	11 3/16
1/16	0.1875	2 1/4	7/16	0.4375	5 1/4	11/16	0.6875	8 1/4	15/16	0.9375	11 1/4
	0.1927	2 5/16		0.4427	5 5/16		0.6927	8 5/16		0.9427	11 5/16
	0.1979	2 3/8		0.4479	5 3/8		0.6979	8 3/8		0.9479	11 3/8
13/64	0.203125	2 7/16	29/64	0.453125	5 7/16	45/64	0.703125	8 7/16	61/64	0.953125	11 7/16
	0.2083	2 1/2		0.4583	5 1/2		0.7083	8 1/2		0.9583	11 1/2
	0.2135	2 9/16		0.4635	5 9/16		0.7135	8 9/16		0.9635	11 9/16
7/32	0.21875	2 5/8	15/32	0.46875	5 5/8	23/32	0.71875	8 5/8	31/32	0.96875	11 5/8
	0.2240	2 11/16		0.4740	5 11/16		0.7240	8 11/16		0.9740	11 11/16
	0.2292	2 3/4		0.4792	5 3/4		0.7292	8 3/4		0.9792	11 3/4
15/64	0.234375	2 13/16	31/64	0.484375	5 13/16	47/64	0.734375	8 13/16	63/64	0.984375	11 13/16
	0.2395	2 7/8		0.4896	5 7/8		0.7396	8 7/8		0.9896	11 7/8
	0.2448	2 15/16		0.4948	5 15/16		0.7448	8 15/16		0.9948	11 15/16
1/4	0.2500	3	1/2	0.5000	6	3/4	0.7500	9	1	1.0000	12

\* From Peele, *Mining Engineers' Handbook*, John Wiley & Sons.

## SURVEYING SIGNALS \*

Except for short distances a good system of hand signals between different members of the party makes an efficient means of communication. The number of signals necessary will depend upon the kind of work and the nature of the country. A few of the more common are given below:

**"Right" or "Left."** The arm is extended in the direction of the desired movement, the right arm being extended for a movement to the right and the left arm for a movement to the left. A long, slow, sweeping motion of the hand indicates a long movement; a short, quick motion indicates a short movement. This signal may be given by the transitman in directing the chainman on line, by the leveler in directing the rodman for a turning point, by the chief of the party to any member, or by one chainman to another chainman.

**"All Right."** Both arms are extended horizontally and the forearms waved vertically. The signal may be given by any member of any party.

**"Plumb the Flag" or "Plumb the Rod."** The arm is held vertically and moved in the direction that the flag or rod is to be plumbed. It is given by the transitman or leveler.

**"Give a Foresight."** The instrumentman holds one arm vertically above his head.

**"Establish a Turning Point" or "Set a Hub."** The instrumentman holds one arm above his head and waves it in a circle.

**"Give Line."** The flagman holds the flag horizontally in both hands above his head and brings it down and turns it to a vertical position. If he desires to set a hub, he waves the flag with one end in the ground from side to side.

**"Turning Point" or "Bench Mark."** In profile leveling the rodman holds the rod horizontally above his head and then brings it down on the point.

**"Wave the Rod."** The leveler holds one arm above his head and moves it from side to side.

**"Pick up the Instrument."** Both arms are extended downward and outward, then inward and up, as one would do in grasping the legs of the tripod and shouldering the instrument. It is given by the chief of the party or by the head chainman when the transit is to be moved.

Care should be taken to make the signals so clear that they may be readily understood. Where long sights are taken or where the peculiar color of the background renders hand signals indistinct, colored flags similar to those of railroad trainmen may be used to good advantage. Of course the color should be in contrast with that of the background. Red can be seen very well against snow, and white can be distinguished clearly against the dark green of the forest.

\* From Raymond E. Davis, *Manual of Surveying for Field and Office*, 1915.



## INDEX

### A

- A soils, 110, 111
- Absorption of aggregates, 33, 136
- Adjustments, levels, 259, 268-276
  - transits, 259-267
- Admixtures, concrete, calcium chloride, 18
- Age-strength relation, concrete, 33
- Aggregate, 134-137
  - batching plant, 8
  - cement finishing, 21, 22
  - colorimetric test, Fig. 17
  - field testing, 134-137
  - fineness modulus, 135
  - mechanical analysis, 134, 135, 141
  - quantity in concrete, 24-39
  - report form, 137
  - sampling for bituminous paving, 139
    - concrete, 10
  - sieve analysis, 134, 135, 141
  - silt and clay in, 135
  - storage and handling, Fig. 16
  - surface water, 33
  - tables, bituminous paving, 153-156, 159
  - voids in, 136
  - water absorption, 33, 136
- Air-entraining cement, 20, 37
  - unit weight test, 12
- Airports, borings for, 100, 106
  - reports, inspectors, 184, 185
  - stakeout, 200
- Analysis, aggregate, sieve, 134, 135
  - bituminous paving, 141
  - soils, by origin, 112
    - mechanical, 124, 125, 133
    - right-angle soil chart, 112
- Angles by repetition, 243, 244
- Arc definition curves, 202, 203
  - length for unit radius, 211
  - welding, 64-71
- Area, average end, 234
  - double end, volumes, 235-239
  - double meridian distance, 244-247
  - formulas, 216, 283, 288
  - pavement surfaces, 155
  - reinforcement per foot of width, 41
- Asphalt, reports, 164
  - sampling, 139

- Asphalt, tables, 152-159
  - tests, 140, 141
  - use of, 150, 151
- Atterberg limits, soils, 110, 113, 114
- Augers, 99, 101
- Average end areas, 234
- A.W.W.A. pipe, cast-iron, 175

### B

- Backhoe, 3
- Basalt, 50, 51
- Batch plant inspection, concrete, 14
- Batching computations, 24, 34-39
  - plant, 8
- Batterboards, structures, 197
- Beams, American Standard Steel, 55
  - concrete, minimum width, 40
- Bearing capacity, piles, 85-87
  - soils, 82
- Bituminous paving, aggregate tables, 153-156, 159
  - areas of surfaces, 155
  - asphalt at 60° F., 156
    - use of, 151
  - bitumen required for, 152
  - bituminous material, use of, 150, 151
  - check list for inspectors, 141
  - correction table, bitumens, 158
  - distributor tables, 157
  - equipment for inspectors, 141
  - field density, 141
  - linear feet per ton of aggregate, 155
  - mechanical analysis, 141
  - mix-in-place, 143
  - pat test, 140
  - pay items, 146, 149
  - penetration, Macadam, 145
    - test, 140
  - percentage of bitumen, 141
  - plant mix, 146-149
  - prime coats, 142
  - reports, 160-164
  - road mix, 143
  - road oil, use of, 150
  - sampling, 139
  - seal coats, 143
  - tables, 150-159

**Bituminous paving**, tack coats, 143  
 tar, use of, 150  
 tests, 141, 150  
 weight of aggregate, 156  
**Borings**, 99-107  
 log, 107, 131, 132  
**Bridges**, 75-80  
 borings for, 100  
**Brownstone**, 52  
**Bucking-in with transit**, 248  
**Bulldozer**, 4  
**Butt welds**, 66, 67

## C

**Calcium chloride**, sampling for concrete, 11  
**California bearing ratio**, 120, 130  
**Cast iron**, identification, 71  
 pipe, 175-177  
**C.B.R.**, 120, 130  
**Cement**, air-entraining, 20, 37  
 -asbestos pipe, 166, 179  
 -factor, 37  
 finishes, 21, 22  
 high-early-strength, 18  
 in concrete mixes, 24-39  
 report forms, 47, 48  
 sampling, 10  
 storage and handling, 14, Fig. 16  
 water ratio, 23  
**Center eyepiece adjustment**, levels, 273, 276  
 transit, 266  
**Centrifuge moisture equivalent**, soils, 111  
**Channels**, structural steel, 55  
**Chapman flask**, 117  
**Check lists**, bituminous paving, 141-149  
 concrete, 13-21  
 foundations, 84  
 grading, 138  
 masonry, 49  
 painting, 81, 82  
 pile driving, 84  
 sanitary construction, 165  
 steel, structural, 53, 54  
 welding, 70-71  
 wood and timber, 94, 95  
**Chord** definition curves, 204, 205  
 lengths, circular curves, 206, 210  
 plotting by, 278  
**Circular curves**, 202-216  
 arcs, length for unit radius, 211  
**Clamshell bucket**, 3  
**Classification of soils**, 108-125  
 report on, 129, 133  
**Clay**, definition, 108  
 identification, 108, 109

**Clay**, in aggregate, 135  
 pipe, 167, 168  
 report, 181  
**Cold-weather concrete**, 17, 18  
**Collimation adjustment**, levels, 270, 274, 275  
 transits, 262  
**Colorimetric tests**, Fig. 17  
**Compaction of soils**, 123  
 calculation, 127  
 inspection, 138  
**Compass needle adjustment**, 266, 267  
**Compressor**, 9, 189  
**Concrete**, 10-48  
 accelerating admixtures, 18  
 age-strength relation, 33  
 aggregate batching plant, 8, Fig. 16  
 absorption, 33  
 surface water, 33  
 air-entraining cement, 20  
 batch plant inspection, 14, Fig. 16  
 batching computations, 24, 34-38  
 cement factor, 37  
 check list for inspectors, 13  
 cold weather, 17, 18, 21  
 construction joints, 17  
 curing, 17  
 equipment for inspection, 13  
 exposed surfaces, 17  
 field inspection, 15, 19  
 field sampling, 10  
 field testing, 12  
 finishing floors, 21, 22  
 machine, 9  
 pavements, 20  
 form inspection, 15, 19  
 frost protection, 18  
 high-early-strength cement, 18  
 load tests, 18, 42  
 material, inspection, 14  
 transporting, 15  
 mixes, 23-38  
 mixing, 15, 19  
 paver, 7  
 paving, 19  
 pay items, 18  
 pipe, 170-174  
 report, 181  
 placing inspection, 16, 19  
 ready mixed, 16  
 reinforcement, 15, 19  
 inspection, 39-41  
 reports, 43-48  
 sand-aggregate ratio, 24  
 sand colorimetric tests, Fig. 17  
 slump, recommended, 23  
 test, 12  
 subgrade, 19  
 tag for samples, 13  
 transit mix, 8, 15

**Concrete**, unit weight test, 12  
 water content, 23  
**Construction**, equipment, 3-9  
 joints, concrete, 17  
 stakeout, 197-201  
**Contractor's daily report**, 188  
**Correction**, table, bituminous materials, 158  
 prismoidal, 240, 241  
 tangents and externals, 209  
 taping, 276  
**Corrugated metal culverts**, 169  
**Crane**, 3  
**Cross wire adjustment**, level, 270, 274  
 transit, 261  
**Crossovers**, 233  
**Cubic yards**, aggregate required, paving, 154  
**Culverts**, inspection of existing, 76  
 pipe, 169, 172-174  
**Curing**, age-strength relation, 33  
 concrete, 17  
 less than 70°, 34  
 liquids, samples of, 10  
**Current**, welding, 70  
**Curves**, 202-232  
 arc definition, 202, 203  
 areas, 216  
 chord definition, 204, 205  
 circular, 202-212  
 layout, circular, 249, 250  
 transition, 217-226  
 vertical, 227-232  
 maximum curvature, roads, 204  
 metric, 212  
 minimum curvature, roads, 204  
 parabolic, 227-232  
 railroad, 204  
 short-radius, 213-215  
 spiral, 217-226  
 transition, 217-226  
 vertical, 227-232  
**Cypress**, Tidewater Red, 90, 91

## D

**Decimal equivalent of common fraction**, 296  
**Deflections**, curves, 203, 206, 210, 215  
**Density**, bituminous paving, 141  
 calculations, 126, 127  
 of soils, 117-123  
**Departures**, latitudes and, 244-247  
 plotting, 278, 279  
**Double-end area volumes**, 235-239  
 centering, 248  
 meridian distance, 244-247  
**Drag line**, 3  
**Dumpy level**, 257  
 adjustments, 268-270, 274-276

## E

**Earthwork computations**, 234-241  
**Effective size**, soils, 125  
**Electrodes**, welding, 68, 69  
**Elongation of Polaris**, 252, 253  
**Equipment**, bituminous-paving inspectors, 141, 142  
 concrete inspectors, 13  
 construction, 3-9, 189-191  
 grading inspectors, 138  
 masonry inspectors, 49  
 pipe-laying inspectors, 179  
 sanitary inspectors, 165  
 structural-steel inspectors, 53  
 welding inspectors, 70  
 wood inspectors, 94  
**Errors**, allowable for surveys, 250-252  
**Expansion joint filler**, sampling, 10  
**Expense record**, 183  
**Externals**, for circular curves, 202-213  
 for transition curves, 217-226  
 for vertical curves, 227-232

## F

**Field moisture equivalent**, density  
 test, 120-123  
 soils, 111  
**Fillet welds**, 65-67  
**Fineness modulus**, 135  
**Finish**, concrete floors, 17, 21, 22  
 pavement machine, 9  
**Fir**, Douglas, 90, 91  
**Floor finishes**, concrete, 21, 22  
 load tests, 18, 42  
**Forms**, concrete, 15, 19  
 removal of, 15  
**Fort Peck sampler**, 103  
**Foundations on soil**, 82-84  
 borings for, 100  
 piles, 84-88  
**Frogs**, 233  
**Frost protection**, concrete, 18  
**Fuller's rule**, 24  
**Functions**, of 1° circular curve, 208  
 of transition curves, 224, 225  
 trigonometric, 289-292

## G

**Gage**, wire and sheet metal, 58, 59  
 wire mesh, 39  
**Gallons**, bitumen required, paving, 152  
**Gneiss**, 50, 52  
**Grader**, motor patrol, 4  
**Grading**, 138  
**Granite**, 50, 51  
**Gravel**, definition, 108



**Gravel**, identification, 108, 109  
**Greenheart**, 90, 91

## H

**Hardwoods**, 92, 93  
**Hemlock**, Eastern, 90, 91  
**Highways**, *see* Roads  
**Hooks** for reinforcement, 40  
**Horizons** of soils, 109

## I

**Inspection**, bituminous paving, 139-164  
 bridges, 75-80  
 concrete, 10-48  
 grading, 138  
 masonry, 49-52  
 painting, 81, 82  
 pile driving, 84-88  
 pipe laying, 179, 180  
 soils, 99, 133  
 steel, structural, 53-63  
 timber, 89-96  
 welding, 64, 74  
 wood, 89-96  
**Inspectors' check lists**, bituminous paving, 141-149  
 concrete, 13-21  
 foundations, 84  
 grading, 138  
 masonry, 49  
 painting, 81, 82  
 pile driving, 84, 85  
 pipe laying, 179, 180  
 sanitary, 165  
 structural steel, 53, 54  
 welding, 70, 71  
 wood and timber, 94, 95  
**Inspectors' report forms**, airport runways, 184, 185  
 bituminous paving, 160-164  
 bridges, existing, 78, 79  
 concrete, 43-48  
 general construction, 186, 187  
 pile driving, 88  
 pipe laying, 181  
 soils, 126-133  
 structural steel, 60-63  
 welding, 62, 63, 72-74  
 wood preservation, 96  
**Inspectors' time record**, 182  
**Invar tape**, 276  
**Iron**, identification, 71  
**Isogonic chart**, 254, 255

## J

**Job power**, 189-191  
**Joint assemblies**, concrete pavements, 19

**Joint filler**, sampling, 10  
 sealer sampling, 10

## K

**Knots**, rope, 98

## L

**Land measure**, 283  
**Larch**, 90, 91  
**Latitudes and departures**, 244-247  
 plotting, 278, 279  
**Layout**, circular curves, 249, 250  
 construction, 197-201  
 transition curves, 217-226  
 vertical curves, 227-232  
**Length**, transition curves, 219  
**Level**, adjustments, 268-276  
 allowable errors, 250, 251  
 dumpy, 257  
 notes, 194, 242  
 wye, 258  
**Lime** for mortar and masonry, 49  
**Limestone**, 51, 52  
**Lineal shrinkage**, soils, 111, 114  
**Linear feet covered**, paving, 155, 157  
**Liquid limit**, soils, 110, 113  
**Load tests**, concrete, 18, 42  
 piles, 87  
 soil, 82, 83  
**Logarithms**, numbers, 294, 295  
 trigonometric functions, 292

## M

**Macadam**, 145  
 material required, 159  
**Manila rope**, 97  
**Maple**, 93  
**Mapping**, 277-282  
**Marble**, 50, 51  
**Marking concrete samples**, 11, 13  
**Masonry**, equipment for inspector, 49  
 identification of stone, 50-52  
 mortar for, 49, 50  
 preparation for painting, 81, 82  
**Maximum density**, soils, 117-119  
**McKiernan-Terry pile hammers**, 86  
*Engineering News* formula, 85, 86  
**Mechanical analysis**, aggregates, 134, 135  
 bituminous paving, 141  
 soils, 124, 125, 133  
**Mesh reinforcement**, 39  
**Metric curves**, 212  
**Minutes in decimals of a degree**, 207, 293  
**M.I.T. soil classification**, 109  
**Mixer**, concrete, 7, 8

**Mixes, concrete, 23-39**  
**Mixing concrete, 15, 16**  
 ready-mixed, 16  
**Mix-in-place, bituminous, 143**  
**Moisture determination, calculations,**  
 126, 127  
 soils, 115-123  
**Moran and Proctor sampler 103**  
**Mortar for masonry, 49**  
**Muck, 108**

## N

**Natural trigonometric functions, 289-**  
 291  
**North, determination of, 252**  
**Notes, surveying, 193, 194, 242, 250**  
**Numbers, logarithms of, 294, 295**

## O

**Oak, 92**  
**Omitted side problem, 247, 248**  
**Optimum moisture, soils, 117-119**

## P

**Painting, 81, 82**  
**Parabolic, curves, 227-232**  
**Parallax adjustment, 261**  
**Pat test, sheet asphalt, 140**  
**Pavement, bituminous, inspection of,**  
 139-164  
 concrete, inspection of, 19  
 concrete paver, 7  
 finishing machine, 9  
 reports, 46-48, 160-164  
**Pay items, bituminous paving, 146,**  
 149  
 concrete, 18  
**Payroll record, 183**  
**Peat, 109**  
**Penetration macadam, 145**  
 material required, 159  
**Penetration test, asphalt, 140**  
**Piles, driving, 84-88**  
 inspection of existing, 75, 76  
**Pine, Eastern white, 90, 91**  
 long leaf yellow, 90, 91  
 short leaf yellow, 90, 91  
**Pipe, cast-iron, 175, 176**  
 cement-asbestos, sewer, 166  
 water, 179  
 check list for inspectors, 179, 180  
 clay, 167, 168  
 concrete, 170-174  
 corrugated metal, 169  
 joint materials, water, 177  
 laying, 179, 180  
 reports, 181

**Pipe, stakeout of, 201**  
 steel, 178  
**Pipe line, stakeout, 201**  
**Piston samplers, 103**  
**Placing concrete, 16**  
**Plant mix, bituminous, 146-149**  
**Plaster, preparation for painting, 82**  
**Plasticity index, soils, 110, 114**  
**Plate adjustment, transits, 265**  
**Plotting, topography, 279-282**  
 traverses, 277-279  
**Polaris, elongation, 253**  
 observation of, 252  
**Power shovel, 3**  
**P.R.A. soil classification, 110, 111**  
**Preservation, wood, report, 96**  
**Prime coats, bituminous, 142**  
**Prismoidal corrections, 240, 241**  
**Proctor needle plasticity test, 117-119**  
**Profile map, soils, 104, 105**  
**Protractor plotting, 277, 279**  
**Pulvi-mix, 6**  
**Pumping, concrete, 17**  
**Pycnometer, 116**

## Q

**Qualification test, welders, 65**  
**Quicklime, 49**

## R

**Radius, circular curves, 202-206, 210-**  
 215  
 transition curves, 217-226  
**Railroad, crossovers, 233**  
 curves, 204, 205  
 frogs, 233  
 stakeout, 199  
 switches, 233  
 turnouts, 233  
**Ready-mixed concrete, 16**  
**Reinforcement, area per foot, 41**  
 beam widths for, 40  
 hook dimensions, 40  
 inspection of, 15, 19  
 mesh, 39  
 sampling, 10  
 sizes of, 40  
**Report forms, aggregate analysis, 137**  
 airport runways, 184, 185  
 bituminous paving, 160-164  
 bridges, existing, 78, 79  
 concrete, 43-48  
 contractors, daily, 188  
 expense record, 183  
 general construction, 186, 187  
 payroll, 183  
 pile driving, 88  
 pipe laying, 181

**Report forms, soils, 126-133**  
 steel, structural, 60-63  
 time sheet, inspector's, 182  
 welding, 62, 63, 72-74  
 wood preservation, 96

**Road mix, bituminous, 143**

**Roads, borings for, 100, 104**  
 stakeout, 198

**Roller, sheepsfoot, 5**  
 tandem, 6  
 three-wheel, 5

**Rope, knots, 98**  
 strengths, 97  
 wire, 97

**S**

**Sag curve, 228**  
 in taping, 276

**Sampling, bituminous paving, 139**  
 concrete, 10, 11  
 soils, 99-107

**Sand, colorimetric test, Fig. 17**  
 definition, 108  
 for concrete, Fig. 17  
 identification, 108, 109  
 sampling of, 10  
 storage and handling, Fig. 16

**Sand-aggregate ratio, 24**

**Sandstone, 51, 52**

**Sanitary construction, 165**  
 pipe, 166-181

**Schist, 50, 52**

**Seal coat, bituminous, 143**

**Seconds in decimals of a minute, 207**

**Section modulus, steel, 55-57**  
 wood, 89

**Sewer pipe, cement-asbestos, 166**  
 clay, 167, 168  
 concrete, 170, 171, 174  
 laying, 179, 180

**Shale, 52**

**Sheet asphalt, pat test, 140**  
 sampling, 139

**Short-radius curves, 213-215**

**Shovel, 3**

**Shrinkage limit, soils, 110, 114**

**Shrinkage ratio, soils, 111, 114**

**Sieve analysis, aggregate, 134, 135**  
 soils, 124, 125

**Signals for surveyors, 297**

**Silt, definition, 108**  
 identification, 108, 109  
 in aggregate, 135

**Sisal rope, 97**

**Skimmer, 3**

**Slate, 52**

**Slump test, 12**  
 recommended, 23

**Soft woods, 90, 91**

**Soils, 99-133**  
 airport test pits, 106  
 analysis of, 108-125  
 Atterberg limits, 110, 113  
 augers, 99, 101  
 bearing capacity, N.Y. City code, 82  
 borings, 99, 100, 107  
 C.B.R., 120  
 centrifuge moisture equivalent, 111  
 Chapman flask, 117  
 classification, 108-125  
 compaction recommended, 123  
 inspection, 138  
 effective size, 125  
 exploration, 99-107  
 field density test, 120-123  
 field moisture equivalent, 111  
 foundation inspection, 82-84  
 horizons, 109  
 hydrometer analysis zone, 109  
 identification of principal types, 108, 109  
 lineal shrinkage, 111, 114  
 liquid limit, 110, 113, 114  
 load tests on, 82, 83  
 mechanical analysis, 124, 125  
 M.I.T. classification, 109  
 mixtures, 112  
 moisture-density relations, 115-119, 123  
 moisture determination, 115, 116, 117  
 optimum moisture, 117-119  
 origin of, 112  
 plastic limit, 113, 114  
 plasticity index, 110, 114  
 P.R.A. classification, 110, 111  
 Proctor needle, 117-119  
 profile map, 104, 105  
 pycnometer, 116  
 reports, 126-133  
 right-angle soil chart, 112  
 samplers, 100, 102  
 sampling, 99-107  
 shrinkage limits, 110, 114  
 shrinkage ratio, 111, 114  
 sieve analysis, 124, 125  
 size of samples, 100  
 sounding rod, 99, 102  
 specific gravity, 116, 117  
 subgrade, 111  
 test pits, 99-101, 106  
 uniformity coefficient, 125  
 unit weight test, 120-123  
 U.S. Bureau of Soils, grain sizes, 109  
 wash borings, 99, 102

**Sounding rod, 99, 102**

- Specific-gravity determination**, aggregate, 134  
soils, 115-117
- Spiral curves**, 217-226
- Spruce**, Eastern, 90, 91
- Stadia notes**, 193, 194  
tables, 195, 196
- Stakeout**, circular curves, 249, 250  
construction, 197-201  
transition curves, 217-226  
vertical curves, 227-232
- Standard beams**, structural steel, 55
- Steel**, bridges, existing, 76  
gages, 58, 59  
identification, 71  
pipe, 178  
reinforcement, area per foot, 41  
beam widths for, 40  
hook dimensions, 40  
inspection of, 15, 19  
mesh, 39  
sampling, 10  
sizes of, 40  
structural, 53-63  
check list for inspectors, 53, 54  
equipment for inspectors, 53  
reports, 60-63, 72-74  
sections, 55-57  
tape, 276
- Storage**, concrete aggregates, Fig. 16
- Structures**, stakeout, 197
- Subgrade**, classification of, 111  
for concrete pavement, 19
- Summit curve**, 227
- Surface**, exposed concrete, 17  
for painting, 81, 82  
water on aggregates, 33, 134
- Surveying**, adjustments, 256-276  
airfield stakeout, 200  
angles by repetition, 243  
areas, double end, 235-239  
double meridian distance, 244-247  
bucking-in, 248, 249  
building stakeout, 197  
curves, 202-232  
arc definition, 202, 203  
areas, 216  
chord definition, 204, 205  
circular, 202-212  
layout of, 249, 250  
maximum curvature, roads, 204  
metric, 212  
minimum curvature, roads, 204  
parabolic, 227-232  
railroad, 204  
short-radius, 213-215  
spiral, 217-226  
transition, 217-226  
vertical, 227-232
- Surveying**, decimal equivalent, common fractions, 296  
double centering, 248  
double end area volumes, 235-239  
double meridian distance, 244-247  
earth work, 234-241  
elongation of Polaris, 252, 253  
errors, allowable, 250-252  
highway stakeout, 198  
instruments, 256-276  
isogonic charts, 254, 255  
land measure, 283  
layout, 197-201, 249, 250  
level, adjustments, 268-276  
notes, 194, 242  
logarithms, numbers, 294, 295  
trigonometric functions, 292  
mapping, 277-282  
minutes in decimals of a degree, 293  
north, determination of, 252, 253  
notes, 193, 194, 242, 250  
pipe line stakeout, 201  
Polaris, 252, 253  
prismoidal corrections, 240, 241  
railroad stakeout, 199  
railroad turnouts and crossovers, 233  
signals, 297  
stadia tables, 195, 196  
stakeouts, 197-201, 249, 250  
taping, 276  
three level sections, 234  
topographic, 193, 194  
transit, adjustments, 260-267  
notes, 193, 194, 250  
problems, 243-252  
stakeout with, 197-201  
traverse, areas, 244-247  
plotting, 277-279  
trigonometric formulas, 283-288  
trigonometric functions, 289-292  
vernier, 255
- Switches**, 233
- Symbols**, mapping, 280, 281

## T

- Tack coats**, bituminous, 143
- Tag**, beam and cylinder, 13
- Tangents**, for circular curves, 202-213  
for transition curves, 217-226  
for vertical curves, 227-232  
plotting by, 277, 278
- Taping**, 276
- Tar**, sampling, 139  
tables, 152-159  
tests, 141  
use of, 150
- Telescope adjustments**, levels, 272, 274  
transit, 263-265

- Tension for taping**, 276  
**Test pits**, 99-101, 106  
**Tests**, beams, concrete, 11  
     bituminous paving, 140, 141  
     colorimetric, Fig. 17  
     concrete, reports on, 45-48  
     cylinders, concrete, 11  
     load, on piles, 87  
         on soil, 82, 83  
     of soils, 113-123  
     slump, concrete, 12  
     unit weight, concrete, 12  
     welding, 65  
**Three level sections**, 234  
**Timber**, 89-96  
**Time sheet**, inspector's, 182  
**Tons**, aggregate required, paving, 153  
**Topography**, mapping, 277-282  
     notes, 193, 194  
     plotting, 279, 282  
     stadia tables, 195, 196  
     surveys, 193  
     symbols, 280, 281  
**Transit**, adjustments, 260-267  
     allowable errors, 251, 252  
     notes, 193, 194, 250  
     problems, 243-252  
     stakeout with, 197-201  
**Transit mixers**, 8, 16  
**Transite pipe**, 166, 179  
**Transition curves**, 217-226  
**Trap rock**, 50, 51  
**Traverses**, double meridian distance,  
     244-247  
     errors, allowable, 251, 252  
     notes for, 193, 194  
     omitted side, 247, 248  
     plotting, 277-279  
**Trencher**, 7  
**Trigonometric formulas**, 283-288  
     functions, 289-292  
**Turnouts**, 233
- U*
- Uniformity coefficient**, soils, 125  
**Unit weight test**, aggregate, 136  
     concrete, 12  
     soils 120-123
- U.S. Bureau of Soils**, classification  
     109
- V*
- Vernier**, 255  
**Vertical curves**, 227-232  
     circle adjustment, transit, 265  
**Volume**, bituminous materials, 156,  
     158  
     double end area, 235-239  
     paving aggregates, 156
- W*
- Wash borings**, 99, 102  
**Water**, absorption by aggregates, 33,  
     136  
     maximum for concrete, 23  
     sampling for concrete, 11  
     surface, on aggregates, 33, 134  
**Water-cement ratio**, 23, 25-32  
**Weight**, bituminous materials, 156  
     paving aggregates, 156  
     pipe, 166-179  
**Welding**, 64-74  
     acceptable profiles, 67  
     current, 70  
     defective profiles, 67  
     electrodes, 68, 69  
     equipment for inspection, 70  
     fillet weld gages, 67  
     positions, 66  
     processes, 64, 65  
     qualifications of welder, 65  
     reports, 62, 63, 72-74  
     weld characteristics, 66  
**Wire gages**, 58, 59  
     mesh, 39  
     rope, 97  
     sampling, 10  
**Wood**, 89-96  
**Wye level**, 258  
     adjustments, 268-274
- Y*
- Yield of concrete**, 34-39





