

Birla Central Library

PILANI (Jaipur State) ,
Engg College Branch

Class No :- 697

Book No :- T 896H

Accession No :- 32392-

Acc. No. 32392

ISSUE LABEL

Not later than the latest date stamped below.

--	--	--

HEATING AND AIR CONDITIONING
EQUIPMENT FOR BUILDINGS

**MODERN AIR CONDITIONING,
HEATING AND VENTILATING**

By WILLIS H. CARRIER, REALTO E. CHERNE,
and WALTER A. GRANT. **25s.** net.

FLATS

Design and Equipment

By H. INGHAM ASHWORTH, B.A., A.R.I.B.A.
25s. net.

ARCHITECTURAL HYGIENE

Or Sanitary Science as Applied to Buildings

By SIR BANISTER FLETCHER, F.S.I., and H.
PHILLIPS FLETCHER, D.S.O., F.R.I.B.A., F.S.I.
15s. net.

BRICKWORK

By E. LINDSAY BRALEY, M.R.San.I., F.R.S.A.,
M.R.S.T. **45s.** net.

**A CONCISE
BUILDING ENCYCLOPAEDIA**

Illustrated

By T. CORKHILL, M.I.Struct.E. **8s. 6d.** net.

**Published by
PITMAN**

HEATING & AIR CONDITIONING EQUIPMENT FOR BUILDINGS

BY
F. BURLACE TURPIN
M.I.H.V.E., M.INST.F.

WITH A FOREWORD BY
A. LEONARD ROBERTS
FELLOW, HON. SECRETARY, AND PAST VICE-PRESIDENT OF THE
ROYAL INSTITUTE OF BRITISH ARCHITECTS



LONDON
SIR ISAAC PITMAN & SONS, LTD.

1948

First Published 1948

SIR ISAAC PITMAN & SONS, LTD.
PITMAN HOUSE, PARKER STREET, KINGSWAY, LONDON, W.C.2
THE PITMAN PRESS, BATH
PITMAN HOUSE, LITTLE COLLINS STREET, MELBOURNE
27 BECKETTS BUILDINGS, PRESIDENT STREET, JOHANNESBURG

ASSOCIATED COMPANIES

PITMAN PUBLISHING CORPORATION
2 WEST 45TH STREET, NEW YORK
205 WEST MONROE STREET, CHICAGO

SIR ISAAC PITMAN & SONS (CANADA), LTD.
(INCORPORATING THE COMMERCIAL TEXT BOOK COMPANY)
PITMAN HOUSE, 381-383 CHURCH STREET, TORONTO



**THIS BOOK IS PRODUCED IN
COMPLETE CONFORMITY WITH THE
AUTHORIZED ECONOMY STANDARDS**

MADE IN GREAT BRITAIN AT THE PITMAN PRESS, BATH
D8—(P.417)

FOREWORD

IN this country it is widely appreciated that the housing conditions under which our people live are important contributory factors to good health, and I am convinced, as I feel sure all the readers of this book will be, that not only the plan of a building and its construction and design, but also the warming, cooling, ventilation, cleansing, humidifying and de-humidifying of the atmosphere within it are details of vital importance to the general health of the community. and should be efficiently provided in the buildings we design and erect for various uses by human beings. To contribute in this way to their good health is to add also to their personal comfort and happiness.

It is with pleasure that I recall hearing Mr. F. Burlace Turpin talk about these matters in the year 1938, and how impressed I was in all he said so clearly about them.

Since Mr. Turpin has decided to publish his knowledge and experience in a simple form for the aid of architects and architectural students especially, I can but hope that the benefits which this book should help to bring about may be available well before the preliminary work which must precede the great building programme now before us is complete.

The importance of avoiding methods of heating that lead to the extravagant use of fuel and power needs no emphasis. To refer to Mr. Turpin's past connection with the Coal Utilization Council is sufficient to assure his readers that due regard is paid to the practice of economy of the national fuel reserves by the use of appropriate methods and appliances for the efficient production and utilization of heat.

In my opinion the book will serve an extremely useful purpose in aiding those for whom it has been specially written.

A. LEONARD ROBERTS

*Fellow, Hon. Secretary, and Past Vice-President
of The Royal Institute
of British Architects*

PREFACE

THE information contained in the following pages is based upon a number of lectures which I was privileged to deliver some years ago to numerous Architectural Societies and Associations, Technical Colleges, and other organizations throughout the British Isles. I have completely rewritten and revised the lecture notes and considerably extended the treatment of the various aspects of the subject, but its substance remains unaltered.

The discussions that followed these lectures made it evident that the need was felt for a fuller exposition of the subject consequent on the increasing complexity of this branch of the mechanical equipment of buildings. It is this reason that has prompted me to supply information of especial interest to those responsible for the planning and construction of buildings and therefore primarily concerned with the selection, installation, and use of such equipment.

To-day the subject of efficient heat utilization is one of very great importance not only because of the shortage and increasing cost of fuel, but in order to be able to provide the better conditions of comfort and hygiene now expected in modern buildings. The provision of needs such as these under present circumstances, together with the urgent necessity to conserve the fuel resources of the country, demands a high economic standard in the use of equipment for its consumption. Only by this means is it possible to utilize the sources of heat to the fullest advantage, and thereby increase its availability to a community whose welfare is so largely dependent upon its use.

I should like to take this opportunity to express my appreciation of the willing co-operation of the many organizations and firms in making available information and providing blocks for illustrations.

F. BURLACE TURPIN

DORSET CHAMBERS
N.W.1

CONTENTS

CHAP.	PAGE
FOREWORD	v
PREFACE	vi

PART I

GENERAL AND TECHNICAL INTRODUCTION

I. GENERAL INTRODUCTION	1
1. Object of the Text	1
2. Problems Encountered	4
II. ATMOSPHERIC CONDITIONS FOR COMFORT and INDUSTRY	7
1. Factors Involved	7
2. Temperature	11
3. Humidity	14
4. Cleanliness	16
III. SIGNIFICANCE OF METHODS USED	20
1. General Considerations	20
2. Radiator Warming	25
3. Ventilating	28
4. Air Conditioning	32

PART II

CONSTRUCTION, FUNCTIONS, AND APPLICATION OF APPARATUS

IV. SPACE WARMING APPLIANCES	36
1. Alternative Types	36
2. Heaters	38
3. Radiators	44
4. Radiant Panels	46
V. HEAT CIRCULATING SYSTEMS	54
1. Alternative Methods	54
2. Water Systems	57
3. Steam Systems	60
4. Air Systems	64

CHAP.	PAGE
VI. VENTILATING APPARATUS	68
1. Alternative Methods	68
2. Extract Systems	70
3. Fresh Air Supply Systems	74
4. Combined Systems	78
VII. COOLING, HUMIDIFYING, DE-HUMIDIFYING, AND COMPLETE CONDITIONING APPARATUS	81
1. Alternative Methods	81
2. Independent Cooling, Humidifying, and De- humidifying Apparatus	83
3. Complete Conditioning Apparatus	87
VIII. CENTRAL PLANT	93
1. Boiler House	93
2. General Arrangement of Plant	97
3. Boilers	99
4. Mechanical Firing Equipment	106
5. Operational Instruments	112
IX. AUTOMATIC TEMPERATURE CONTROL APPLIANCES	117
1. Reasons for their Use	117
2. Alternative Methods	121

PART III

**FUELS, THERMAL INSULATION, DISTRICT HEATING, HOT
WATER SUPPLY, LOCAL HEATING APPLIANCES, PLANS,
SPECIFICATIONS. AND TENDERS**

X. FUELS	127
1. General Considerations	127
2. Alternative Fuels	129
3. Fuel Economy	134
XI. THERMAL INSULATION	139
1. Value of Insulation	139
2. Insulation of Buildings	143
3. Insulation of Apparatus	147
XII. DISTRICT HEATING	152
1. General Considerations	152
2. Distribution Systems	156

CONTENTS

ix

CHAP.

PAGE

XIII.	HOT WATER SUPPLY APPARATUS	160
	1. General Requirements	160
	2. Alternative Systems	163
	3. Subsidiary Apparatus	167
XIV.	LOCAL HEATING APPLIANCES	170
	1. Alternative Methods	170
	2. Solid Fuel Appliances	174
	3. Gas Appliances	180
	4. Electrical Appliances	186
XV.	PLANS, SPECIFICATIONS AND TENDERS	193
	1. Extent of Requirements	193
	2. Submission of Tenders	196
	3. Award of Contract	197

PART IV

INSTALLATION OF APPARATUS

XVI.	SPACE WARMING APPLIANCES	203
	1. Heaters	203
	2. Radiators	209
	3. Radiant Panels	211
XVII.	CIRCULATING APPARATUS	217
	1. Pipes and Fittings	217
	2. Ducts and Registers	222
XVIII.	VENTILATING AND AIR CONDITIONING APPARATUS	226
	1. Heaters, Air Cleaners and Fans	226
	2. Coolers, Humidifiers, and Unit Conditioners	229
XIX.	CENTRAL BOILER PLANT	232
	1. Boiler House Equipment	232
	2. Flues and Fuel Stores	237
XX.	INCIDENTAL BUILDERS' WORK	245
	1. General Requirements	245
	2. Summary of Items	246

CHAP.	PAGE
XXI. THE COMPLETED INSTALLATION	249
1. Verification of Performance	249
2. Functional Defects	251
3. Avoidance of Faults	254
 GLOSSARY	 257
 APPENDICES	 261
A. Heat Transmittance Coefficients	262
B. Air Change and Temperature Rise	264
C. Thermal Conductivity and Resistivity of Build- ing Materials	267
D. Insulation for Impact Sound	269
E. Atmospheric Pollution	270
F. Fuels	272
G. British Degree Days	274
H. Fuel Cost Charts	275
 INDEX	 279

PART I

GENERAL AND TECHNICAL INTRODUCTION

CHAPTER I

GENERAL INTRODUCTION

1. Object of the Text. It is the aim of these chapters to endeavour to contribute to the solution of the many problems that confront those who are ultimately responsible for the selection and installation of warming, ventilating, and air conditioning apparatus. The subject has been approached from a special point of view—one that is not to be found in orthodox textbooks, which are normally published for the benefit of the engineering student and practitioner, and are of necessity full of technicalities.

The treatment of the subject has been undertaken from the viewpoint of the purchaser, and those acting on his behalf, who require information of a different character. They are usually not concerned with technical details of design and the scientific *modus operandi* of apparatus, but seek to know how best to utilize the material at their disposal in order to provide, efficaciously and economically, particular atmospheric conditions. Information is therefore given upon two specific aspects of the subject—the extent of the different types of equipment available and their various functions and applications—so that discrimination may be exercised in their use.

Increasing complexity in heating and air conditioning methods, together with greater variety of appliances, renders more difficult the task of making a right choice, and makes it necessary to keep in touch with modern progress.

Planning should aim at providing modern standards of comfort and service from a plant which will not soon become obsolete. This can only be achieved by sound methods and proper standards of hygiene and economy, applied with due regard to æsthetic considerations.

It is now being realized that the construction of a building of whatever class cannot be regarded as complete unless it is provided with some form of central warming or air conditioning apparatus. To render this modern complement of architecture fully effective it is necessary both for its utilitarian value to be apparent and for a fuller understanding of its wider applications to be promoted.

This necessity has become the more apparent during recent years,

owing to the extensive progress made in methods of atmospheric conditioning.

There is to-day, in regard to the class of equipment to be described, a tendency for scientific progress to outstrip the ability to apply it to the best advantage, such as occurred in the last century in regard to appliances in general. During this period innovations accumulated to the confusion of those who were concerned with their utilization because they possessed insufficient engineering knowledge to enable the inventions to be used intelligently. In much the same way to-day the full interests of the owner of a new building are sometimes neglected, not so much because of any intention to deprive him of benefits to be derived from the use of more appropriate methods or apparatus, as because of a lack of appreciation of the general applications of the equipment. This is evidenced by the want of balance exhibited between architectural and utilitarian values in the planning of some present-day buildings.

It is nowadays, of course, necessary because of shortage and increasing cost to curtail the amount of fuel used for space heating, ventilating, and hot-water supply, in order to conserve resources. Therefore, the aim in the following text is to encourage the use of those appliances and methods that combine maximum economy with the most efficient production and utilization of heat. Only by a careful selection of the means available will future installations and buildings give the highest standard of comfort and convenience combined with the greatest possible economy.

Throughout, an attempt has been made to explain the motives underlying the use of different equipment, according to the prevailing circumstances, and in correspondence with the facts. There has been no attempt to describe the mechanical principles of the various systems and appliances, or the materials and methods used in their manufacture, nor to give precise details of their design. It is considered that information of this character would serve little useful purpose in a text of this description, and would tend to confuse the the real issues. The object has rather been to facilitate the selection and installation of apparatus for the benefit of the purchaser by omitting all irrelevant matters.

There has also been no attempt to deal with every item of apparatus involved in the provision of the atmospheric conditions required in a building, since the aim is to present information affecting architectural considerations in particular in preference to those of an engineering character.

The importance of giving the whole subject every consideration cannot be over-emphasized if a building, on completion, is to be an acknowledged success in all its aspects. To many concerned with the design and construction of buildings the necessity of making provision for their warming, ventilating, or air conditioning is often the cause of some anxiety, lest deficiencies in the installation of apparatus prejudices the merit of an otherwise creditable building achievement. That this feeling is sometimes justified is apparent from instances to be seen in some buildings to-day, where the installation of such apparatus has not only seriously detracted from the aesthetic features of a building, but has been the cause of criticism on practical grounds, due to circumstances which, in many cases, could have been foreseen and avoided. Difficulties of one kind and another must, of course, arise from time to time in any undertaking, but they can be minimized if due regard is given to known requirements in the initial and all subsequent stages of planning.

It is upon the early and close collaboration of those concerned with architecture and the mechanical equipment entailed that the success of a building largely depends; and of no less importance is the necessity for this co-operation to continue during the course of construction if completion is to be entirely satisfactory. Without collaboration of this nature difficulty must be experienced in securing the economic and other standards essential for the proper installation of equipment and its subsequent operation.

Failure to select equipment when a building is first being designed may subsequently increase costs, as the apparatus will have to be considered at a later stage. By carefully co-ordinating appliance installation requirements with structural design, both functional and economic requirements are satisfied, and later complications avoided.

The information given is thus intended for the benefit of those who, being uncertain of the best procedure to adopt to fulfil their own particular requirements and wishing to avoid the errors that can be made in any new undertaking, are also anxious at the same time to improve the general internal condition of buildings. From the text of the book many of the precautions necessary for avoiding the pitfalls known to exist should become apparent.

The method adopted in the presentation of the work will, it is hoped, be found helpful, and serve to clarify a subject which to some may have become confusing owing to the increasing variation that is occurring in the modern applications and installation of

apparatus. The considerations embraced by the subject have been classified and sectionalized, and under each heading is included a summary of the appliances, systems, methods, materials or general procedure applicable in their respective categories. This arrangement has also been adopted to facilitate prompt reference to any particular item required which, by nature of the text, cannot be adequately covered by the general index. It has not been possible to avoid the use of a certain number of technical terms in order to deal both conclusively and concisely with the various subjects included, and for the purpose of reference a glossary of such terms is given at the end of the book.

2. Problems Encountered. The planning and construction of a modern building, whether it be for private or commercial use, involves many problems in addition to those of an architectural or structural character. Because of the varied forms of construction and methods of application of mechanical equipment, those concerned with its use may sometimes feel in doubt as to how their requirements may best be met.

Uncertainty often arises even in the minds of those familiar with these matters, when called upon to choose between alternatives of apparently equal merit. To others, less familiar with the subject, difficulties of a more diverse character present themselves, such as the extent of the treatment to be given to the atmosphere, the practicability of installing one particular type of system in preference to another, or the advisability of using certain forms of invisible warming panels in preference to the orthodox radiator. Other problems may involve the choice of electrical, liquid, gaseous or solid fuels, the application of thermal insulation, the choice of contractor and the method of allocation of the contract.

An important factor in considering these problems is that of cost—both the initial cost of the installation and its operating cost, which has now become of greater significance owing to the increased cost of installation and fuel. The task of selecting appropriate apparatus is considerably simplified if cost is not a prime consideration. Unfortunately, however, more often than not cost is the limiting factor in the construction of a building, necessitating strict economy in the purchase of equipment. Where this is so, vigilance must be exercised to ensure that not only is the correct type of equipment installed to provide the service required, but that adequate service is provided under all conditions and is maintained for a minimum outlay.

Considerations of economy must, of course, be taken into account in purchasing mechanical apparatus in general, but when attempting to apply them to the purchase of equipment of the class in question, many variable factors are involved.

The initial or installation cost of apparatus, as distinct from its operating cost, being governed chiefly by capacity or output and the type of equipment used, requires special attention. Extravagance in the selection of the atmospheric conditions to be provided must therefore be avoided. Equally important is the saving to be made by selecting apparatus which is economical in both the material and labour required for its provision.

The operating cost of an installation is of greater significance than may be at first apparent since it is a continuous expenditure. This should, therefore, be considered in conjunction with the initial cost of apparatus, since the latter must necessarily react upon the former. The cost of operation, being mainly dependent upon the purchase price of the class of fuel consumed and the amount of labour entailed in its consumption, together with the efficiency and quantity of heat produced, and method of distribution used, should receive close investigation. Circumstances such as these require that appropriate classes of fuel, correct types of space heating appliances and boiler plant, and sound methods of heat conservation are utilized. Incidental to these precautions other difficulties may at the same time be overcome, such as the overheating of a building by the provision of improved conditions of warmth.

The submission of tenders for the execution of the contract has also been known to create doubts on the part of the recipient, not only on account of the conflicting proposals submitted and diversity in estimated costs, but for other reasons. For example, tenders sometimes include a number of "optional" extra costs, which have been quoted for alternative, or additional, items of equipment.

Some items of this nature may be superfluous and some necessary for the satisfactory performance of the installation, and their significance must therefore be appreciated in order that a wise decision may be made as to which should be included and which omitted. Keen competition in the submission of tenders sometimes also results in the provision of something less than the bare minimum of equipment necessary for satisfactory service, and these deficiencies can be detected only by acquiring a knowledge of the real requirements.

It may be said that the choice of suitable systems and apparatus might conveniently be left entirely to the discretion of the vendor, but experience has shown that this is not always a wise procedure for numerous reasons. Owing to strong competition in the submission of tenders, a tendency exists to install stereotyped systems and forms of apparatus, in order to minimize the costs of the installation, regardless of the other considerations. Alternatively, it may be that a contractor's experience of the design and installation of systems and apparatus is limited to the provision of certain particular types, and he is consequently reluctant to jeopardize his position by proposing more suitable installations of which he has little experience. It is also feasible that the use of patented systems may be proposed by monopolistic firms, in the desire to eliminate competition for the contract.

Considerations such as those already mentioned, and others of a different character, to which reference is made later, suggest the need for the purchaser to acquaint himself with the various classes of installation available, so that he may, at least, be in a position to inquire into the use of alternative arrangements. Such a precaution should provide, in some measure, an assurance against the possibility of installing inappropriate equipment, and the unnecessary expenditure of large sums of money.

ATMOSPHERIC CONDITIONS FOR COMFORT
AND INDUSTRY

1. Factors Involved. Before considering the various systems and apparatus available for the provision of warmth, coolness, and fresh air in a building, it is as well to reflect upon what constitutes a satisfactory atmospheric environment and the factors involved in its production. This aspect of the subject is not only of importance in its effect upon the general service to be provided by the apparatus, but is of significance in relation to its cost and that of the fuel consumed, as these will be mainly dependent upon the atmospheric conditions selected.

To maintain itself in a state of physical comfort and mental activity, the human body must be able to dissipate to the atmosphere heat, moisture and gas in quantities proportional to its activities, and upon this free exchange of thermal, aqueous and gaseous matter depends the well-being of the individual. The body, for instance, when at rest under normal temperature conditions is capable of giving off from its surface, and by respiration, approximately 400 British Thermal Units of heat, 770 grains of moisture, and 1,000 cu. in. of carbon dioxide every hour, and the state of the atmosphere, therefore, should be capable of absorbing and dispersing these elements if physical discomfort and ill-health are to be avoided.

That is why it is important for the ambient atmosphere to be maintained in a condition appropriate for the transference of these human organic functional products, although it is now recognized that carbon dioxide is the least harmful vitiative element in its general effect upon the individual. In addition, concentrations of solid impurities in the air should not exceed certain limits if the general health of the individual is not to be impaired. Finally, adequate movement of the air around the individual should be maintained to give full effect to these requirements as a whole.

Bodily emission of heat, which occurs in the form of evaporation, convection and radiation, is governed by the temperature of surrounding surfaces, and of the air, its humidity and movement, and on these will depend the body's rate of thermal transmission and the conditions of comfort provided.

The greater proportion of heat lost by a body is by convection and radiation, and when the relative losses by these two means vary, so will the feeling of comfort alter. This is one of the factors that influences the choice of a method to provide warmth in a building, since transmission of heat either primarily by convection or radiation from a system will effect the conditions of comfort obtained. If, for instance, body radiation heat losses are reduced by radiant heat from an appliance, then the temperature of the air should be reduced or its rate of movement accelerated in order to increase convection loss from the body and so maintain thermal equilibrium. Thus the feeling of comfort remains unaltered.

Air temperature by itself, even when maintained at a constant level, does not provide ideal conditions of comfort. The co-ordination of air and environmental surface temperatures, humidity and air movement, is, therefore, necessary before a specific degree of each of these ensures desired conditions, which will be further influenced by unidirectional radiation and air movement, and air temperature gradient. As an indication of how these variable factors may be defined to produce a particular environment, the following example is given of the conditions that may be required—

Air temperature	65° F.
Mean radiant temperature	68° F.
Relative humidity	50 %
Air velocity	30 ft. min.
Air temperature gradient, max.	10° F.
Overhead radiant temperature, max.	100° F.

The relationship between temperature and humidity with specific air movement which produces the same sensation of temperature is known as “effective” temperature, a scale of which has been compiled from research and experiment, to establish a recognized zone of comfort which can be verified by the use of testing instruments. The chart shown in Fig. 1. serves to illustrate the manner in which these variable factors affect the conditions produced as recorded in the United States. In this country the zones would be a few degrees cooler to conform with the different standard of comfort required. The effect of air temperature and movement, together with radiation from surrounding surfaces known as “equivalent” temperature, may also be assessed by suitable measuring instruments, but until some simple method is available to determine the optimum effect of all these factors such as is indicated by the “corrected” effective temperature, reliance must continue to be placed upon the ordinary

thermometer, suitably shielded, as a means of ascertaining if a building is sufficiently heated.

If a more exacting index is required of the conditions provided in a building by the heating installation and the form of building

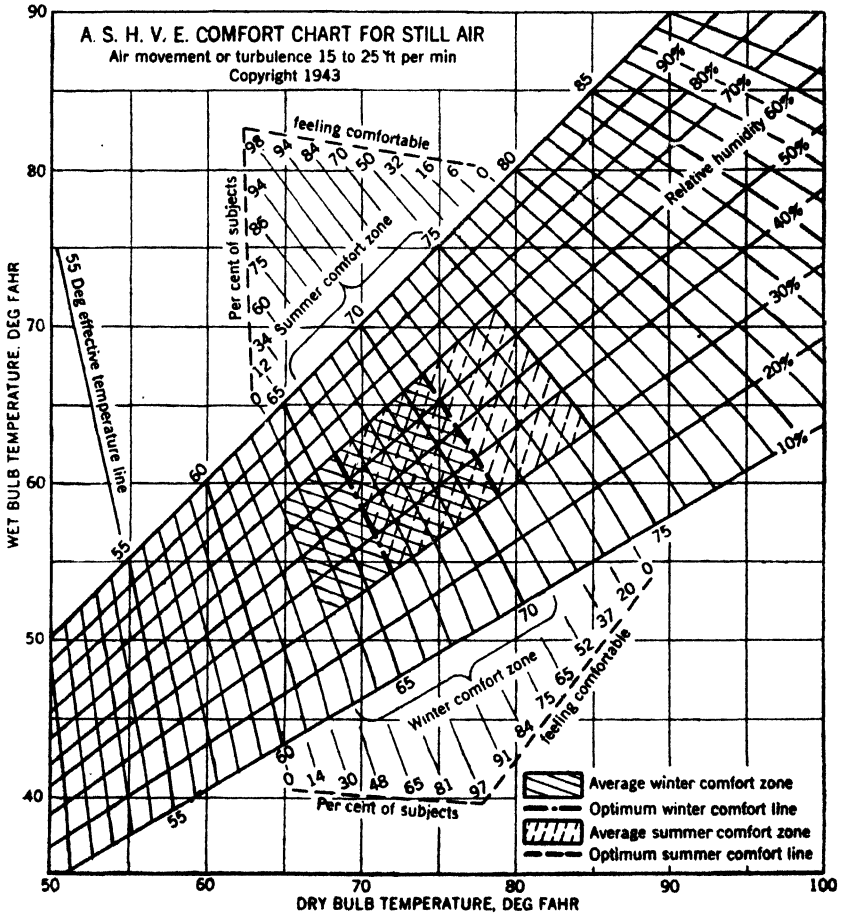

FIG. 1. COMFORT CHART FOR STILL AIR

Note. Both summer and winter comfort zones apply to inhabitants of the United States only. Application of winter comfort line is further limited to rooms heated by central station systems of the convection type. The line does not apply to rooms heated by radiant methods. Application of summer comfort line is limited to homes, offices, and the like, where the occupants become fully adapted to the artificial air conditions. The line does not apply to theatres, department stores, and the like where the exposure is less than three hours. The optimum summer comfort line shown pertains to Pittsburgh and to other cities in the northern portion of the United States and Southern Canada, and at elevations not in excess of 1000 ft. above sea-level. An increase of 1° E.T. should be made approximately per 5° reduction in north latitude.

(Reprinted from *Heating, Ventilating, Air Conditioning Guide*, 1945, Chap. 2.)

construction used, a portable apparatus (referred to in Chapter XXI) may be used to determine the equivalent temperature.

The necessity of securing and maintaining exact conditions in the state of an atmosphere becomes essential if it is desired to provide perfect comfort. This is evidenced by recent investigations which show that a variation of between two and three degrees of effective temperature is sufficient to alter the average persons' feeling of ideal comfort.

Maintaining a constant percentage of relative humidity in the atmosphere at the appropriate temperature not only produces a favourable reaction upon the individual, but, irrespective of temperature, produces significant changes in the state of materials and goods of a hygroscopic nature. For this latter reason the control of the moisture content of the atmosphere becomes important, as this facilitates manufacturing processes undertaken in connection with such materials as textiles, paper, celluloid, ink, timber, and tobacco. In the case of food processing, production is not only simplified but is carried out under more hygienic conditions.

The scientific progress made in the treatment of air for improvement of the atmosphere within a building has enabled its condition to be mechanically regulated to produce changes of a diverse character. Thus it is now practicable to control the state of an atmosphere, within accurately defined limits, in order to provide the environment required under different circumstances. When air is being conditioned it undergoes many changes in physical composition. It may, for example, be warmed or cooled and saturated or dried, and also washed or dry cleaned in addition to being ionized, ozonized, and deodorized.

Chemical sterilization of the atmosphere for the control of airborne infection is also a process receiving careful consideration. This is because investigation has shown that the air of enclosed spaces is mainly responsible for the dissemination of respiratory disease.

The constitution of properly mechanically conditioned air is analogous to that prevailing in a state of ideal climatic conditions, and it will be seen that the functions of the various mechanical systems to be described do not all reproduce these conditions or the variations required for industry.

Conditioning of the atmosphere consists of partial or complete treatment according to the process to which it is subjected. Air that is only partially conditioned may be merely changed in temperature as with some form of heating or cooling appliance functioning in

the space to be treated, or only be cleansed by filtration before distribution throughout a building. Alternatively it may be heated or cooled without being humidified or de-humidified in any way. In each case the air will remain incompletely conditioned since it has undergone only partial treatment.

Air to be fully conditioned must undergo treatment that will effect whatever changes are necessary in the state of its temperature, humidity and cleanliness to provide an atmosphere in conformity with particular requirements. Due regard, therefore, must be given to these three factors in the course of its treatment, together with adequate movement of air throughout a building. On this account the term "air conditioning," when applied to an apparatus, may prove misleading unless further qualified, since certain types of apparatus are intended to condition air only to a limited extent.

Such factors as those described prevail in the general conditioning of air, and by the use of aerodynamics, thermometry, psychrometry, and chemical screen and other tests, certain standards have been set up for its temperature, humidity, purity and velocity according to individual requirements. By this criterion is assessed the extent of the service to be provided by the apparatus, and its design is formulated accordingly.

The extent of warming and cooling of the air admitted to a building must depend upon individual requirements of temperature and humidity. According to meteorological records, to maintain air at a temperature of 65 deg. F. and 50 per cent relative humidity, for example—an atmospheric state which may be regarded as generally satisfactory for comfortable conditions—it may be necessary in this country to provide heating and cooling for over 200 days annually. The period within the year when both heating and cooling are coincident occurs when de-humidification is necessary if the relative humidity is to remain at 50 per cent in the treated atmosphere.

2. Temperature. It will be seen from the conditions governing the provision of warmth that the amount to be provided depends mainly upon the occupational use made of a building, either as a whole or in its several parts. The activities of the occupants, therefore, will generally govern the temperature to be provided since physical exertion is a means in itself of maintaining bodily warmth. Other factors, however, such as the effect produced by certain manufacturing processes, thermal insulation, and the method of warming used will influence the temperature required.

Air temperature alone, it has been noted, cannot be expected to

provide entirely satisfactory conditions since discomfort must be felt in an environment where everything is cold except the atmosphere. It is therefore desirable to provide a reasonable degree of thermal insulation in the building structure so that the temperature of walls and ceilings will not remain excessively low. This is further countered when radiant heat is also employed in these surfaces or from an independent source.

The mean radiant temperature of surrounding surfaces must therefore play an important part in the provision of a satisfactory environment since thermal radiation, in either positive or negative form, is one of the four factors governing bodily heat exchanges. Recent tests have confirmed that comfort can be produced in an air temperature of about 55 deg. F., provided there is an adequate supply of radiant heat of appropriate wavelength.

The comfort level for an individual is about 30 in. above floor level, as this is found to be a more accurate index of the temperature affecting comfort than at breathing level. A particular degree of temperature, however, will not be acceptable to every individual as the optimum comfort temperature and those in the minority whose requirements differ in this respect should vary their clothing accordingly as it is often impossible to please everyone sharing the same environment. Owing to the differences in dress of the two sexes and also their constitution a difference of about 4 deg. F. in the temperature of the air appears to be necessary to produce the same feeling of comfort.

The examples of air temperatures¹ given in Table I are typical of those required according to usage of the space warmed and as measured by an ordinary thermometer. Their actual effect as has been seen, will be influenced to some extent by the proportion of any radiant heat that may be provided with the convective heat together with an air movement, which combine to produce an equivalent temperature.

In the living rooms of residences where the body is usually at rest and giving off a normal quantity of heat, an air temperature in the region of 60 to 65 deg. F. (about 65 deg. F. equivalent temperature) is considered satisfactory, a slightly higher degree being preferable for elderly people and those of sub-normal vitality. A similar temperature for workers engaged in sedentary forms of occupation, such as in offices, is advocated, as for all other classes of buildings where the physical exertions of the occupants is similar.

¹ See Appendix B for detailed Table.

Bedrooms in residences or hotels are generally maintained at an air temperature of 5–15 deg. below that recommended for living rooms. It is considered that a higher temperature should be avoided for health reasons and because the body is generally covered with bedclothes, and so suffers no discomfort from a lower temperature. But individual requirements in this respect will differ widely, and for this reason appropriate conditions can be obtained only by the personal pre-selection of temperature such as is possible with automatic temperature control.

TABLE I
AIR TEMPERATURE REQUIRED IN BUILDINGS

Room or Building	Air Temperature F.
Residences: Living Rooms	60–65
Bedrooms	50–60
Halls and Corridors	50–60
Offices	65
Hospitals: Wards and Staff Rooms	65
Operating Theatres	80
Restaurants	60–65
Churches and Museums	50–60
Warehouses	50–55
Cinemas and Theatres	55–60
Factories: Heavy work	55
Light work	60
Sedentary work	65
Schools	60–65
Hot-houses	75–80

The degree of warmth to be provided in entrance halls, vestibules and corridors should be intermediate to that of the general temperature within the building and that of the average temperature without, so that the contrast upon entering or leaving the building will not be too severe.

The temperature to be maintained in factories and other classes of industrial buildings depends upon the nature of the work undertaken by the operatives, and varies both according to whether the effort called for is strenuous or otherwise and the extent of radiant heat provided by machinery and other plant. When the operatives are employed as machinists, or on small assembly or other light work, a substantial portion of which is done sitting and does not involve serious physical effort, a temperature of at least 60 deg. F. is required after the first hour.

In lofty buildings, such as churches and assembly halls, it is sometimes advantageous to compromise in the provision of temperature by localizing the warmth to be provided. By this means it is unnecessary to raise in temperature the entire volume of air in a building if the warmth is concentrated where actually required, as can be effected by the use of local radiant heating. In this way, the mean temperature of the atmosphere throughout the building is much reduced, and the temperature of the air surrounding the occupants can also be less due to the effect of radiation. This latter effect, however, is more pronounced with high temperature radiation.

The temperature provided when the air in a building is cooled should be maintained in accordance with the prevailing external temperature. The difference between the two atmospheres should not exceed 10–15 deg. F., otherwise the contrast is likely to cause shock to the human system when individuals are entering or leaving the building.

The various air temperatures recommended for warming purposes are those provided when the outside temperature does not fall below freezing point. In view of the infrequency of temperatures occurring below this point, and their brief duration, any increase necessary for reserve purposes in the maximum air temperature rise allowed, other than that normally provided, would not in general justify the larger capacity of apparatus required, and the consequent additional cost entailed.

3. Humidity. For the provision of conditions for bodily comfort, as distinct from industrial requirements, the amount of moisture desirable in the atmosphere is, as already mentioned, dependent to some extent upon its temperature, but unlike temperature it is unnecessary to maintain the relative humidity of the air within the same close limits to ensure similar conditions of comfort. If the percentage of relative humidity is to vary extensively it is better for it to diminish rather than increase with the higher extremes of temperature, as is apparent when experienced under natural climatic conditions. An instance of this is the "sirocco," a hot, moist, oppressive air experienced in parts of the Mediterranean which sometimes causes a variation in relative humidity exceeding 50 per cent over a period of a few hours.

A relative humidity between 50 and 60 per cent is the ideal to be attained at average indoor temperatures for individuals of normal health. For others who suffer from certain disorders of the respiratory system, a lower percentage is often found to be more beneficial.

In hospital operating theatres a comparatively high percentage is desirable to minimize the risk of anæsthetic explosions due to the discharge of static electricity.

The condition of the building structure itself may also be affected internally according to the quantity of moisture in the air. This is sometimes found to be a contributory cause of condensation on the surface of walls, ceilings, fixtures and furniture, the moisture having been deposited because the dew point temperature of the air is above that of these surfaces.

The humidity required for commercial or industrial purposes depends upon the nature of the processes undertaken and the character of the materials used in manufacture, and on this account, as indicated in Table II, it varies to some considerable extent. Artificial humidification in textile factories is, however, restricted under certain conditions by regulations.

To season timber, for example, the air used should possess a high moisture absorption capacity after initial drying and must, therefore, be of low relative humidity. In the textile industry the weaving of cotton and manufacture of artificial silk necessitates a specific relative humidity to prevent the material from becoming difficult to handle during processing. A high humidity reduces electrification as the electrical resistance of textile fibres decreases rapidly with increased humidity.

In the printing trade it is necessary to provide a comparatively high humidity to prevent excessive evaporation of ink on the rollers of machinery, or to retain the required state of gelatinous compound used in engraving. Colour printing entails, in some processes, accurate registration, and to obtain this it is necessary that the paper should not alter in size or shape due to expansion or contraction as a result of changes in its moisture content. The humidity required must, therefore, be constantly maintained at the required figure. Tobacco used in cigarette making and for pipe smoking, when being prepared and packed, requires a certain humidity so that its condition may remain unaltered to comply with conditions of sale and to enhance its smoking qualities.

Manufactured and processed food, including canned foodstuffs, are, in many instances, more expeditiously produced under cleaner conditions, and made more palatable in a proper atmospheric environment.

Many other materials or produce used in manufacturing processes have been found to respond favourably to particular atmospheric

conditions of humidity, which suggests that investigations carried out in connection with substances at present processed under ordinary atmospheric conditions may prove that they react advantageously when subjected to controlled humidification.

The stabilization of atmospheric conditions in a building in this way to meet the requirements of certain industries is necessitated by the wide and sudden variation that occurs in the climate of Great

TABLE II
DESIRABLE HUMIDITIES FOR INDUSTRIAL PROCESSING (*A.S.H.V.E. Guide*)

Industry	Relative Humidity per cent
Brewing	30-50
Ceramic	35-65
Confectionery	30-65
Drug	20-40
Electrical	5-70
Food	38-85
Fur	50-65
Leather	95
Paint	25-50
Photographic	50-70
Printing	45-78
Rubber	25-48
Textile	50-85
Tobacco	55-85

Britain. These changes, which are continually taking place, can produce a difference in relative humidity of 15 per cent within an hour, a change of state that is not uncommon in many districts. Throughout the season the wet bulb temperature frequently exceeds a variation of 30 deg. F.

4. Cleanliness. To ensure a reasonable standard of purity of the air it was at one time considered necessary to maintain its condition within prescribed chemical limits by controlling the proportion of CO_2 present from respiration and other causes. An addition of 0.1 per cent of this gas in the air in excess of normal proportions represented the average permissible increment. It has since been established that the same air can be breathed for extensive periods without harm, and that under normal circumstances other factors, such as temperature, humidity and the presence of organic and mineral matter and odours, are more important vitiative elements, and produce a harmful effect before the presence of carbon dioxide gas becomes offensive. Body odour is recognized as one

of the main causes of an unsatisfactory atmosphere and its concentration has been used as a basis for assessing ventilation requirements. At the same time the percentage of CO₂ present should not be entirely disregarded, since high concentrations may imply that the air is laden with other impurities.

Amongst these other impurities, dust and carbon particles are in greatest evidence and prove most troublesome. Particles of dust of various descriptions when of high concentration are known to be an irritant to the mucous membrane of nose and throat and may also prove to be the cause of allergies. Carbon particles are a particular nuisance owing to their blackening effect and the rapid deterioration they cause to building and other finishes, and the soiling of fabrics and wearing apparel.

To prevent high concentrations of heat and excesses of contaminated moisture, odours, micro-organisms and other matter, the air within a building must be changed continuously. The air introduced from without must also be purified if it is polluted because of its proximity to busy thoroughfares and factories, or by other sources of contamination arising from industrial undertakings, or as the result of climatic conditions.

The necessary frequency of interchange of the air, therefore, is governed by the amount of heat and the extent of vitiation produced by the conditions prevailing in a particular building, and will accordingly be dependent upon its use. The degree of filtration required for entering air will, of course, depend upon the extent of its external contamination by sources already mentioned. This will vary considerably according to the district and time of year as shown by records which indicate that the total solids deposited from the atmosphere per square mile can exceed 30 tons per month.¹

The amount of ventilation provided may be based on an allowance of a specific volume of fresh air per person, or when the number of occupants is unknown, in accordance with a volume related to the capacity of the space ventilated. This is known as "airchange."² In general, however, ventilation based on airchange cannot be other than fundamentally unsound as this cannot always be related to cubic contents and the sources of contamination.

The quantity of replacement air to be allowed hourly for the ventilation of residences, for instance, is based upon the use and exposure of the room concerned and usually varies from one to two times its volumetric capacity. In assembly halls or theatres, where

¹ See Appendix E.

² See Appendix B.

conditions require a higher rate of airchange, an allowance of 1000 cubic feet per hour for every person or seat, represents a minimum quantity. A similar or greater allowance per head for the maximum number of persons accommodated in ballrooms or dancing halls is necessary to counteract the unpleasant atmosphere that is otherwise created by the additional heat dissipated, and moisture and odours exuded, in these circumstances.

TABLE III
AIRCHANGE REQUIRED IN BUILDINGS

Type of Building	Air Changes per hour
Cinemas and Theatres	5-15
Kitchens, large	10-20
small	20-40
Lavatories	5-10
Offices, above ground	2-5
below ground	10-15
Restaurants	5-10
Schools	2-6
Factories	1-3
Workrooms	6-8
Workshops, unhealthy trades	20-30
Boiler Houses and Engine Rooms	10-15

Kitchens of restaurants or hotels, and other buildings, require the air to be renewed every few minutes to maintain normal conditions, which may necessitate as many as twenty or more changes per hour. Boiler houses, particularly those in which oil or coke is consumed, should be sufficiently ventilated to prevent the accumulation of odour and sulphuric gases, and the allowance made may require to be not less than fifteen changes.

Certain industrial processes demand special treatment to provide satisfactory conditions for the workers without which the atmosphere would otherwise become obnoxious or irrespirable. In shops where cellulose solutions are used, a high rate of change must be provided to remove the vapours. The removal of dust produced from abrasive grinding wheels and other types of machinery, and of fumes from chemical apparatus, is accomplished, not by numerous changes of the entire atmosphere in the shop, but by withdrawal of the dust and fumes direct from the various sources of production. Partial changing of the air will also suffice, in certain circumstances, when heavier-than-air gases are to be removed from a building.

Further particulars of ventilation allowances are given in Table III.

The necessary extent of cleansing of the air to be used for interchange is mainly decided by locality. In all large commercial and industrial centres it is necessary to filter the air to a lesser or greater extent according to the amount of pollution of the atmosphere, which may be accentuated by weather conditions.

Some particulars of air filters for use with mechanical systems of ventilation are given at the end of Section 3 in Chapter VI dealing with "ventilating apparatus."

Assessment of the density of organic and mineral matter in the air may be carried out by weight or on the visual screen particle count basis, in addition to discoloration tests to indicate the concentration of solid impurities. Photomicrography, for example, leaves no doubt of the deposit resulting on a given area of surface from a specific volume of air. The concentration of air-borne bacteria may in the near future prove to be a further means of assessing the degree of air contamination.

SIGNIFICANCE OF METHODS USED

1. General Considerations. The essential features in the provision of heat and fresh air within a building are those that ensure its equable distribution throughout the space in quantities sufficient to maintain the appropriate temperature, humidity, cleanliness and motion. It must not obtrude upon the senses, and it should emanate from an appliance that is compact, hygienic and in harmony with the surroundings. Heat and air so distributed should conform to economic standards of production and utilization, and continuity of supply should be assured under all normal conditions of use.

There are two distinct methods for transmitting heat to the atmosphere and occupants of a building. The first method enables the atmosphere to be warmed by direct contact with a heating appliance that is either located (and exposed to view or encased) in the space to be warmed or, alternatively, positioned at some remote central point. The appliance may take the form of a particular type of heater, radiator or radiant panel fixed throughout the building, or in the case of the alternative, one main heater battery situated at a convenient point in a distributing system of air ducting connected to inlet and extraction registers in the spaces warmed.

The second method is one that permits the appliance to warm the atmosphere indirectly, by the latter's contact with the building structure itself. The structure is heated either by an appliance concealed at numerous points within the fabric of the building or, infrequently, by the presence of warm air within the fabric circulated from a remotely situated appliance. These indirect methods, which rely upon the building material itself as a medium by which to transmit heat to the atmosphere, objects and occupants of a space entail the use of appliances interposed or embedded within and throughout the building structure, or the provision of ducts within the structure for the circulation of warm air.

Fig. 2 shows in diagrammatic form some of the more generally adopted methods of utilizing space-warming appliances of various descriptions used with central heating systems.

As a medium for the conveyance of the heat to be made available at a central point within the building, water, steam and air present

a range of alternatives from which to select one that can be made appropriate when raised to suitable pressures or temperatures. It will be seen that the final choice will be dependent upon variables

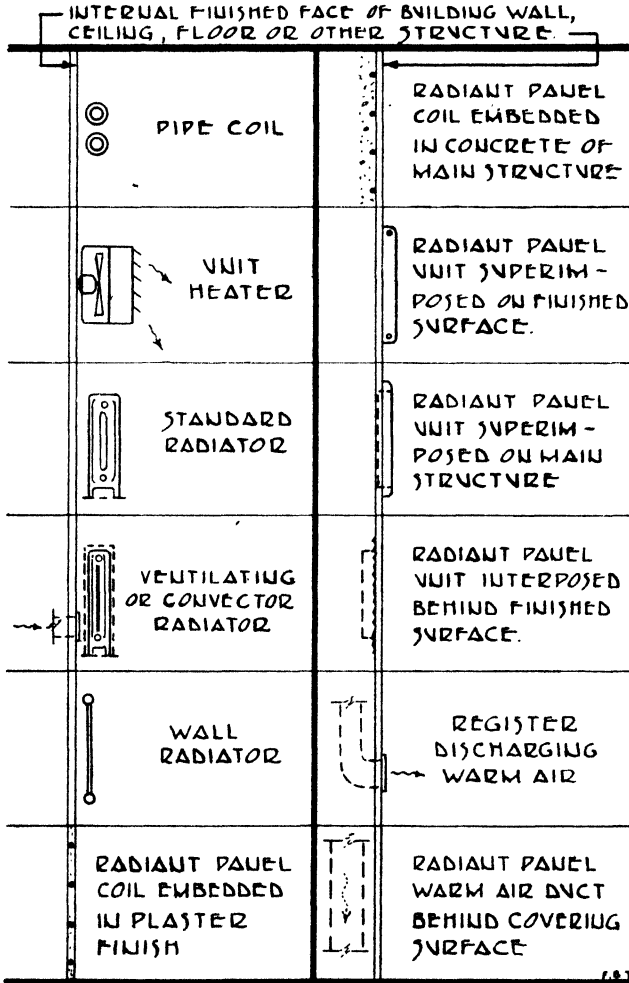

FIG. 2. WARMING METHODS

Diagram of some alternative methods of applying space-warming appliances.

ultimately governed by the character of service the installation is to provide and by the class of building concerned.

The means of efficiently producing the heat to be circulated throughout a building must depend upon the class of fuel used and

the type of equipment utilized for its consumption. Each of these factors presents further alternatives that not only affect the general service to be provided but also influence planning of the building itself. In addition to the use of heat obtained by the combustion of liquid, or solid fuel within the building, or made available by the heat pump, that supplied from external sources in the form of electricity and gas, or hot water and steam from central generating stations, will also affect the allocation of space inside a building and the provision of structures in the building's erection.

In the provision of heat for warming the atmosphere, the quantity required, together with the thermal productive and emissive properties of the equipment used, will largely determine the initial cost of the installation. The quantity of heat required will determine the capacity or output of the installation; the productive and emissive properties of the equipment will govern the type and extent of apparatus used.

In the utilization of heat (as distinct from its provision represented by the potential heat output of the apparatus) the cost of procuring and distributing it will determine the operating cost of the installation. Here again the economical utilization of heat will be dependent upon the type of equipment used, which will vary according to the methods employed in the transition of heat from its source of supply to the atmosphere, and as a consequence of the class of fuel consumed.

Further factors influencing both the initial and operating cost of an installation are those relating to radiant methods of warming, the introduction of thermal insulation in the construction of a building and installation of apparatus, and automatic control methods for the regulation of heat distribution. Centralization or decentralization of plant are alternatives in the arrangement of a system that will also effect costs if the building site is extensive, and the respective merits of each method in given circumstances must therefore be ascertained.

The benefits of basic or "background" heating should also be considered both in regard to independent central systems and district heating systems. Basic heating, which is a partial provision of warmth by centralized or other apparatus, functions in conjunction with the use of independent local appliances which provide the balance of heat when this is required in full. This compromise, when applied to residential buildings in particular, is one that secures economic advantages in certain respects, since it provides a datum

or background temperature as a minimum for health and comfort which is often sufficient in itself in many instances.

This form of heating, which may be regarded as a transitory phase, is also a means of allowing the owner of the building to permit the occupants to make their own selection of an appliance to occupy the "fireplace" or other space available, for the purpose of providing the ultimate temperature or "topping up" warmth.

The concealment of the appliances and circuits of the system used is a feature that is being recognized as one of particular merit in the mechanical equipment of buildings, since it offers certain advantages. The partial or entire concealment of apparatus within the building structure must, therefore, also affect the method of heat distribution used and the cost of the installation.

The greater use of power-driven mechanical equipment entails consideration of the problem of noise transmission that may occur through the building structure itself or pipes, ducts and the air. This is a factor of importance in those classes of building where some degree of quietness is essential and makes necessary the use of apparatus whose design and method of installation render them less audible in operation.

In contemplating the installation of local solid fuel appliances, it must be decided whether to use one that throws the heat usefully outwards into the space to be warmed or wastefully upwards to the outside atmosphere. The selecting of local appliances in general will often depend upon the amenities provided by their use—the monetary value of which may be difficult to assess but which should nevertheless, be given due consideration in particular circumstances.

In the provision of ventilation, careful consideration needs to be given to the different methods available, but there is not the same number of alternative appliances in use as for heating purposes, which simplifies the task of selection. Natural or mechanical ventilation is one of the major features to receive attention, and in the use of the latter the possibility of its functioning for the dual purpose of providing warmth and fresh air together must not be overlooked. If ventilation only is required preference must be given either to a partial or complete mechanical circulation of the air as provided by its forced introduction into or extraction from a building, or by a combination of both. In addition, the alternative arrangements to be made for cleansing of the air require investigation.

Cooling, humidifying or complete conditioning also does not present the same alternatives in methods or appliances as warming

as far as their effect upon the building structure is concerned, although zoning may have some effect in this respect. Cooling,

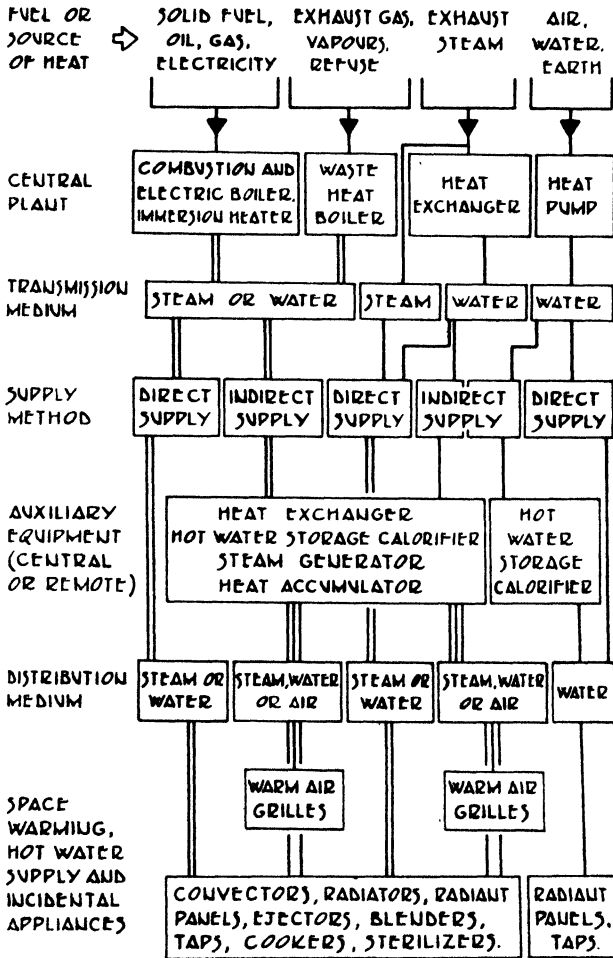

FIG. 3. HEATING SYSTEMS

Diagram showing different methods of utilizing and distributing heat available in different forms.

humidifying or de-humidifying by itself can be undertaken independently with apparatus designed expressly for this purpose. Complete conditioning, however, can be achieved only by one of the orthodox methods available, either as a centralized system or as an independent unit.

Fig. 3 indicates some of the different methods available for utilizing heat in various forms, together with means of distribution.

The modern trend of architectural design shows an avoidance of elaboration. This charm of simplicity and precision in the design of buildings has made apparent the value of eliminating everything unnecessary, not so much for reasons of economy as because the process of elimination accentuates the essential character of the structure. The design of mechanical equipment has likewise altered to conform with the new forms of construction involved. Other considerations such as economy, hygiene, and the more scientific use of heat and air have led to the development of modern apparatus, but simplicity of design embodied in the internal treatment of modern buildings has been chiefly responsible for the class of space-heating equipment now installed.

2. Radiator¹ Warming. The methods of radiator warming that have evolved from the use of heat supplied from central sources of production have developed through stages reflecting the progress made in the design and application of space-warming appliances and equipment in general. This progress, resulting in a large measure from advancement in the design and construction of buildings, has produced various methods of warming which can be made to conform with the requirements of modern architecture when appropriate appliances are utilized.

Some examples of the more recent applications of radiant panel appliances are shown in Fig. 4.

In the selection both of a system and of the space-warming appliance itself, the particular types to be used will be influenced by such factors as the effectiveness desired in transmitting heat from the appliance to the atmosphere and individuals, appearance, first cost, thermal efficiency, building constructional details, and the heat transmitting media used from the boiler plant. One or more of these factors will be found to take precedence over the remainder, according to the circumstances, and depending upon their relative importance the ultimate choice is made.

The manner in which these different factors may exert their influence is best explained by example. It has been noted, for instance, that the thermal productive and emissive properties of the equipment used will largely determine its type and extent, and in consequence its initial and operating cost. This is evidenced

¹ The use of the term radiator here is intended to embrace all types of heat emitters.

by comparing and contrasting a high temperature system using unit heaters embodying hand-fired boiler plant, with a low temperature system using radiant panels and mechanically fired boilers. The former system, by virtue of its compact form of heater of high emissivity and boiler plant of relatively low thermal productive efficiency, requires the minimum of material and labour for its installation, and is consequently comparatively low in initial cost. Conversely, the latter system, using an extended form of heating

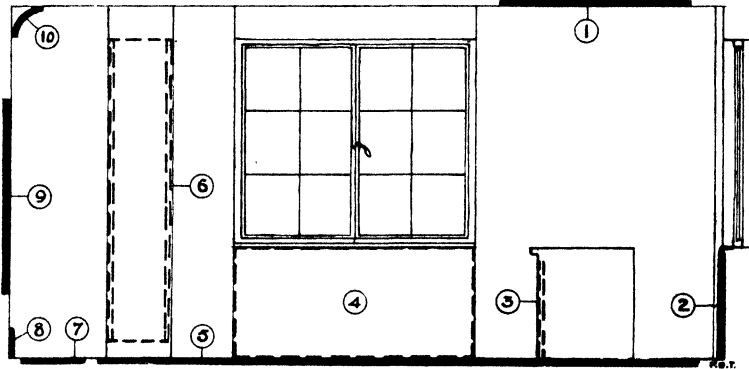

FIG. 4. DIFFERENT APPLICATIONS OF WARMING PANELS

- | | |
|---------------------------------|-------------------------------------|
| 1. Embedded in ceiling. | 6. Interposed on supporting column. |
| 2. Superimposed on wall. | 7. Interposed as floor border. |
| 3. Interposed as counter-front. | 8. Superimposed as skirting. |
| 4. Interposed on wall. | 9. Embedded in wall. |
| 5. Embedded overall in floor. | 10. Superimposed as cornice. |

surface of low emissivity and additional boiler plant of higher thermal efficiency, necessarily involves more expensive equipment. The heat output of the two systems can be similar, but the heating and other effects produced by each will be very different for reasons to become apparent later.

The normal working temperature of the space heating appliance will be dependent upon its type and duty, according to whether or not it functions mainly upon the principles of convection or radiation in the transmission of heat and the purpose for which the heat is to be used. The type of appliance used, therefore, will also affect the media employed for the transmission of heat from the centralized plant, the temperature or pressure of the water or steam varying according to individual requirements.

Heating by convection, which enables the heating surface of the appliance to be used in compact form, as in a heater or radiator, is a method which, depending upon the motion of air (or fluid) for the transfer of heat, concentrates that transmitted in the near

vicinity of the appliance before its ultimate dispersal to the entire atmosphere, which becomes stratified in temperature. The final disposition of the greater proportion of heat emitted by convection is accordingly at a high level.

Heating by radiation, which is little affected by air movement, entails the use of an appliance with an extended flat or curved surface when as a low temperature radiant panel, to obtain emission equal to that of the convector type, and distributes the heat with relative uniformity, ensuring its ultimate equable dispersal throughout the atmosphere. Little variation of temperature is created in the air at different levels since it is almost unaffected by the dissipation of radiant energy.

Reference has been made in Section 2 of Chapter II, to the need for the interior wall surface of a building to be at a temperature not below that of the air temperature considered necessary for bodily comfort, and it should, preferably, be maintained a few degrees above this temperature. At lower temperatures excessive heat will be lost from the body by radiation to the cooler surrounding surfaces (unless counteracted by a high temperature source of radiation) and a feeling of cold experienced. This implies that in addition to adequate thermal insulation it is desirable to provide warmth by heating surfaces of the interior building structure by means of radiant methods rather than to rely entirely upon the effect produced by convection.

Convection heating cannot always be entirely dispensed with, as can be seen in the thermal effect produced by a window. This part of the building structure in chilling the air in contact with the glazing causes the air to fall rapidly to the floor level, where a cold spot may be created. This down-draught, which may reach a velocity of more than 150 feet per minute, will cause discomfort to persons adjacent to windows unless counteracted by the provision of convection heating below. As radiant heat loss may continue from the body to the colder surface of the glazing despite this intervening warm "blanket" of air created by rising convection currents, the cooling effect produced can only be completely counteracted by a source of radiant heat from an appliance which may also be that providing the convection heating.

To achieve a general improvement in the warming of many types of buildings, radiant transmission of heat is becoming the orthodox method, its effectiveness having been proved by its increasing utility.

A resultant of the effect produced by the different methods of heat transmission is to be seen in the vertical temperature gradients

that occur with the use of appliances that depend mainly for the emission of heat either upon convection or radiation. Some of the gradients likely to occur are shown in the graphs in Fig. 5 which are those that may be produced under normal conditions of operation in the average type of building. It will be noted that

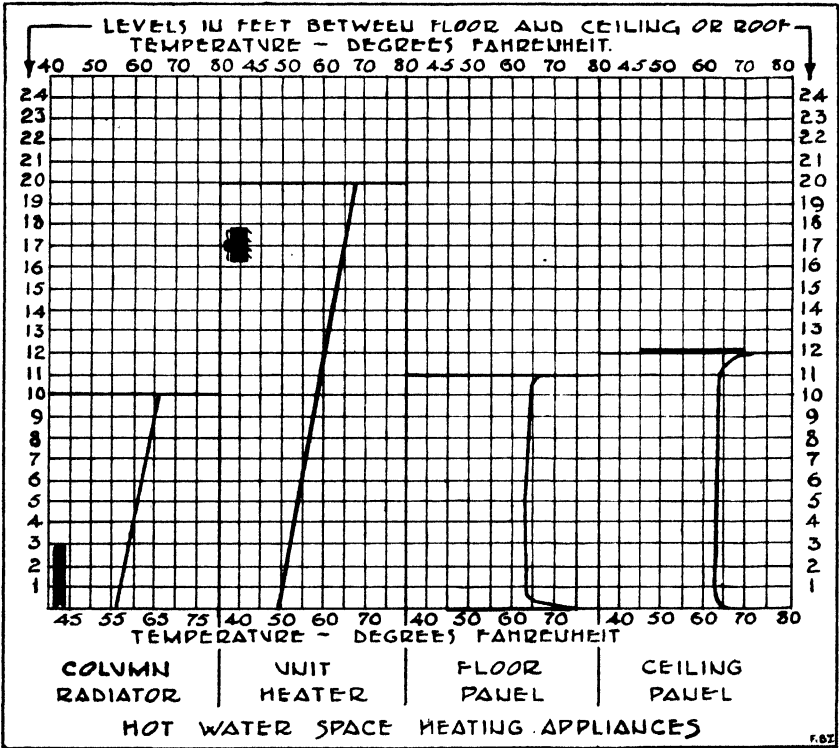

FIG. 5. VERTICAL TEMPERATURE GRADIENTS
Variations in gradient produced with different types of space-warming appliances.

an appreciable variation occurs in the temperature of the air at different levels when warmed by a heater and radiator, as compared with that which is produced by radiant panels. This not only affects conditions of comfort but reacts detrimentally in other ways.

Reference is made to the significance of temperature gradients in the section on "Heaters," Chapter IV, and that dealing with "Fuel Economy" in Chapter X.

3. Ventilating. Improvements in building technique, manufacturing processes, mode of living and other causes together with the

realization that it is important for the air we breathe to be of equal purity to the food we eat and the water we drink, have made apparent the greater need for increased ventilation, and more positive means for its provision. Not only are building materials themselves now more impervious to air but its ingress is further reduced by virtue of the component parts now used in construction. Steel casements have decreased the leakage of air that occurs with timber frames, and the leakage is further restricted by closer fitting doors that are constructed complete with frames in the factory. The supply of air is also diminished by the use of fitted carpets. Building accommodation below ground level, internal compartments without direct external windows, and overcrowding, are all contributory causes demanding more adequate ventilation. The increase in tobacco smoking is also an important reason for increased ventilation as this habit, under certain conditions, increases the quantity of air necessary per person in an occupied space to four or five times that formerly required.

The cleanliness of the atmosphere maintained in a building depends on the extent of its vitiation within due to occupational influences and that without due to locality. These two factors will mainly influence the method to be used to provide the required atmospheric conditions, as also will the class of building concerned. Conditions may be such that natural ventilation in conjunction with a particular type of space-heating appliance will suffice. Circumstances may, however, require the use of mechanical ventilation in combination with heating appliances, or an alternative system of heating that embodies ventilation as part of its function. In other circumstances an air conditioning system may be necessary to fulfil requirements satisfactorily.

For proper ventilation, air should not be allowed to enter or leave a building of its own accord, and in the selection of any method it is important to ensure that the apparatus chosen and installed is capable of effecting adequate control of air flow in the particular circumstances in which it is circulated.

The amount of air to be introduced into a space where for instance vitiation is caused only by the occupants themselves and not by any process undertaken by them, or caused by heating appliances, will depend upon the amount of space allowed for each person. For example, when the space allotment per person is equal to 400 cu. ft., an air volume of 10 cu. ft. per minute for each individual will be provided by only one and a half changes per hour. This allowance of air

per person is considered satisfactory under such conditions when the allotment of space conforms with normal standards.

The extent to which natural means may be used for ventilation, other than through windows and doors, is restricted by the quantity of air that may be induced to enter and leave a building, and is therefore dependent upon the arrangement of the type of appliance used for this purpose and the prevailing state of the external atmosphere. It is a method that may be used to supplement natural ventilation which, by itself, is insufficient to meet all requirements without creating draughts.

The maximum ventilation under natural conditions can best be provided by a vertical shaft or flue, and it is recommended that such be used for the outlet of air in habitable rooms during winter time. For the inlet of air an adjustable wall or window opening to the external air appropriately positioned should be provided. During the remainder of the year it is considered sufficient to provide an adjustable opening of an area equivalent to a specific ratio of the room's floor area. Local by-laws, which must be observed, vary in this respect, however, as some require a ventilator of 50 sq. in. in flueless rooms.

To ensure the positive movement of specific quantities of air to provide adequate ventilation for all purposes, mechanical means must be adopted. This method may be used to extract vitiated air to be replaced by natural ingress or, when necessary, to introduce the replacement air itself. The mechanical extraction of vitiated air as the sole means of ventilation can be satisfactory if the interchange required represents a moderate quantity of air. If considerable interchange is required, such an arrangement will have to be substituted or supplemented by the mechanical introduction of fresh air. This alternative is necessary in order to avoid draughts caused by untempered air entering the building at various points to replace that extracted.

The draught that can be created by the infiltration of unheated air induced to enter a building through window frame and other joints as the result of mechanical air extraction is seen by the effect produced in the opposite way by the influence of a 15 miles per hour wind. A wind velocity such as this when acting upon wooden sash and steel framed windows can account for a difference in air volume of 50 cu. ft. per hour per foot run of crevice. This also emphasizes the need for doors and windows to be reasonably close fitting if the interchange of air is not to be excessive with a pronounced difference of air pressure on either side of the structure.

Combining both fresh air supply and extraction systems not only ensures a more positive circulation of air throughout the building,

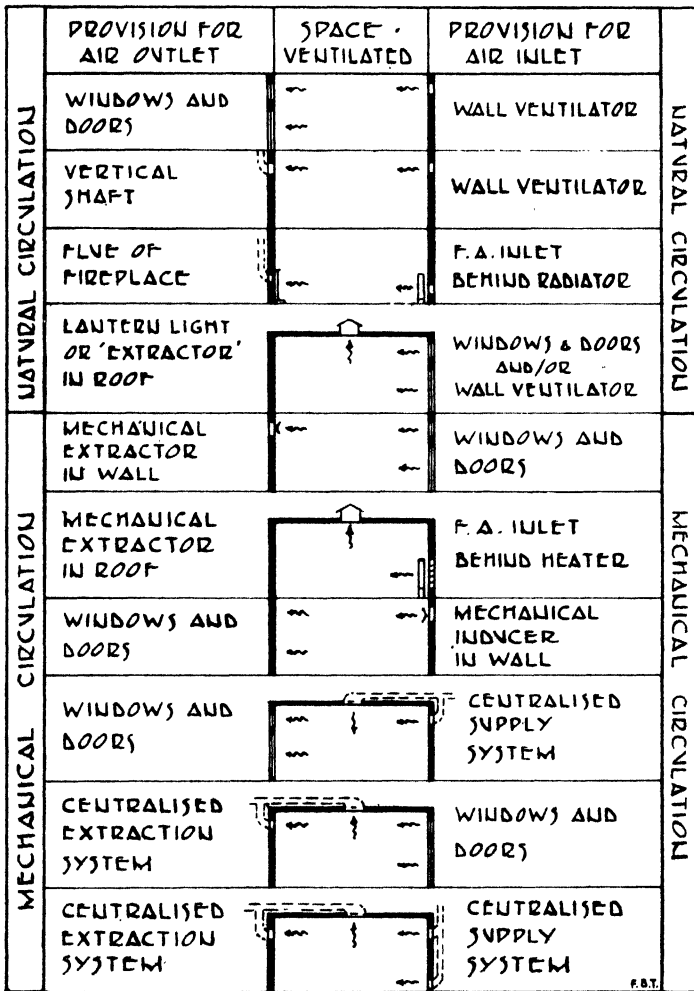

FIG. 6. VENTILATING SYSTEMS
Various methods of providing ventilation.

but, in providing the necessary variation between the volumes of air introduced and extracted, eliminates the tendency for air to infiltrate from one section of a building to another, as it does when either system is installed independently.

The mechanical introduction of heated air, for jointly warming

and ventilating a building is an alternative to the use of individual heating appliances operated in conjunction with independent ventilating apparatus that has been found to provide satisfactory conditions in certain respects. This method of supplying heat and fresh air together is one that enables adequate warmth and ventilation to be provided, but, like other systems using individual heating appliances which rely mainly upon the circulation of air for the distribution of warmth, it is seldom economically effective in operation if without mechanical extraction owing to the air temperature gradient produced.

The forced introduction of warm air combined with its evulsion, for both warming and ventilating a building, is a further method that overcomes the objections arising from only the mechanical introduction of air for this purpose. Such a combined arrangement (which can be made to introduce and extract air in much the same way as a complete air conditioning system) may be used as an alternative to a radiator or panel warming system working in conjunction with a fresh air supply and extraction system. It cannot, however, be expected to produce the same atmospheric effect as the latter method embodying panels.

Some of the various methods that can be used to provide ventilation are shown diagrammatically in Fig. 6.

The mechanical methods referred to may be put into practical effect either by the use of independent apparatus functioning in the spaces treated or by centralized apparatus designed to supply air to, and extract it from, these spaces indirectly. Preference for one or the other types of apparatus will be dependent upon the size and number of spaces concerned, their situation in relation to the external atmosphere, and its degree of cleanliness, together with the class of building concerned.

4. Air Conditioning. The need for the provision of a specific internal atmosphere, engendered as it has been both by concentrations of humanity in confined enclosures and by industrial advancement, has resulted in the use of methods enabling the air supplied to buildings to be appropriately conditioned and to remain unaffected by external conditions. This has been achieved by mechanical equipment that is able properly to co-ordinate and control certain constituents and characteristics of air.

Air that is supplied both to warm and to ventilate a building should, for reasons already explained, maintain a proper relation between temperature and humidity in order to provide entirely

satisfactory atmospheric conditions. This can be assured only by the use of a system that completely and continuously conditions the atmosphere by a process in which cooling is also entailed. Conditioned air to be fully effective, in addition to being processed before distribution, must also be kept in motion throughout the building. This is ensured by the extraction of vitiated air in addition to the supply of conditioned air from carefully selected points so that stagnation is avoided.

The atmospheric temperature of a building may be lowered by the supply of air that has been merely reduced in temperature by its contact with cooling coils. This method of partial conditioning functions irrespectively of any specific humidification required, since the amount of moisture present in the air must fluctuate according to its wet bulb depression's reaction to this method of cooling. Normally, the relative humidity is increased by the lower temperature produced. De-humidification will occur, however, when the air is cooled below its dew point temperature.

When the moisture content of the air is of importance for industrial purposes, humidification may also be provided without involving complete conditioning. The method by itself often permits of no accurate control of temperature, nor is ventilation always secured as a result.

A convenient feature in the entire conditioning of the atmosphere is the "fixed dew point" control, in which the air to be circulated is brought to saturation and its temperature in this state automatically controlled. This enables the moisture content of the air supplied to a building to be regulated.

The temperature of the air saturated by its passage through an air washer to which no heating or cooling medium has been introduced will be its wet bulb temperature, but its total heat content will remain unaltered, the apparent cooling ensuing being due to a fall in dry bulb temperature. It is, therefore, necessary to extract heat from the air (as may be effected by lowering the temperature of the washer water) if it is to be at a constant humidity and at the same time able to remove heat from a building sufficiently to reduce its atmospheric temperature when necessary. To obtain a reduction in the washer temperature a supply of naturally cooled water may be used, but generally the result must be produced mechanically by means of refrigeration.

The process involved in washing the air to induce saturation also cleanses it to some extent but cannot be relied upon entirely for this

purpose when its vitiation due to internal or external influences is at all severe. Air that has become abnormally polluted, e.g. by fog or manufacturing processes, must be subjected to additional cleansing processes to ensure its adequate purity.

Complete air conditioning is a term which infers complete control within pre-determined limits of the temperature, humidity, cleanliness, and movement of air in buildings. It may be provided either by centralized apparatus arranged to supply air to the various



SERVICE	EQUIPMENT	LOCATION
HUMIDIFYING		SPRAY WATER JETS IN OVERHEAD SUPPLY MAINS
DEHUMIDIFYING		ADSORBER UNIT IN CONDITIONED SPACE WITH REMOTE HEAT AND REFRIGERATION SUPPLY
COOLING		OVERHEAD UNIT WITH REMOTE REFRIGERATION
		SELF CONTAINED UNIT IN CONDITIONED SPACE OR ADJOINING
COMPLETE CONDITIONING		AIR SUPPLY AND EXTRACT GRILLES CONNECTED TO CENTRAL CONDITIONER

FIG. 7. AIR CONDITIONING SYSTEMS

Diagram of some different methods used for conditioning air, showing general arrangement of equipment.

sections of a building requiring treatment (which may necessitate certain apparatus being de-centralized to fulfil any zoning requirements) or by the use of independent units functioning in the spaces to be conditioned. The use of one or the other forms of apparatus is usually determined by the extent of conditioning required, by the cost of apparatus, and by its adaptability to existing buildings.

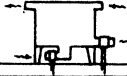
Some of the different means that may be used to treat the air in the various ways described are shown diagrammatically in Fig 7.

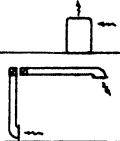
It should be remembered that the state of the atmosphere existing within a building when fully conditioned is such that the admission

of air by means other than those provided by the apparatus is superfluous, and is, in fact, detrimental to the proper functioning of the system. On this account air locks at entrances should be provided and windows must remain permanently closed and may accordingly be double-glazed for the insulation of heat and sound.

Air conditioning other than for industrial requirements is necessary in buildings which accommodate the public in considerable numbers and where, in order to attract custom, it is desirable to provide a comfortable atmosphere under all conditions. A fully conditioned atmosphere in a basement or sub-basement will increase the commercial value of that part of a building, especially when it is used to accommodate the public and would otherwise be unfit for this purpose in certain circumstances. For other classes of non-industrial buildings, air conditioning is largely dependent on whether one is prepared to pay the extra cost of securing the maximum of comfort.

There is no doubt that fully conditioned air increases the efficiency of an individual both mentally and physically to an appreciable extent in certain circumstances, but it is difficult to assess what this increase represents in monetary value when applied to workers in commercial establishments. It is, however, a matter worthy of careful consideration when it is remembered that sickness and resultant absenteeism of staff is reduced by an improved atmosphere, as shown by records compiled over a period of several years.

The extra costs incurred for the necessary equipment when reviewed in connection with many industrial applications is not difficult to justify owing to the economic advantages resulting from the use of fully conditioned air. It must necessarily be comparatively high but when considered in relation to the service provided, which comprises warming, cooling, ventilating, humidifying, de-humidifying and air washing, the cost for such a multi-purpose installation cannot be regarded as excessive.

PART II
CONSTRUCTION, FUNCTIONS, AND
APPLICATION OF APPARATUS

CHAPTER IV

SPACE-WARMING APPLIANCES

1. Alternative Types. This chapter describes those types of appliance which depend upon heat supplied from a central source. Other "local heating appliances," which generate their own heat, are referred to in Chapter XIV.

During the past quarter of a century in particular, many changes have taken place and considerable progress has been made in the design and construction of appliances for the transmission of heat to the atmosphere. As a result of the improvements carried out, the types now in use have superseded former obsolete types and offer an increased range. During this transitional period design and materials have changed, permitting applications to satisfy all the requirements of a modern building.

This greater range of application has necessarily rendered the selection of appliances more difficult and their installation more exacting owing to the more intricate fixings entailed. At the same time these changes have enabled a higher all-round standard to be attained.

The appliances that are now available to transmit the heat from the medium within the system to the atmosphere and directly to individuals vary in form of construction according to the manner in which they function. Partly on this account, and for other reasons, it is both possible and desirable to classify the various appliances according to the method of heat transmission employed by them. This simplifies the selection of an appliance for use under specific conditions of operation because reference to its classification indicates the principle under which it functions.

Despite the modifications made in appliances to suit present-day needs, the particular type generally known as a "radiator" continues to be so mis-called, although there are now other types to which the term is more appropriate. Because of this ambiguity and to avoid confusion in subsequent references it is necessary to set out the various types of apparatus embraced by the different terms.

The appliances are classified into three main categories, sub-divided as follows—

Heaters. Pipe coils, unit heaters, convector and column radiators.

Radiators. Wall radiators and convector radiant radiators.

Panels. Superimposed, interposed, and embedded panels.

Many of these types of appliances have been designed to fulfil a specific purpose such as reduction in the initial cost of the installation, a saving in floor space, improvement in appearance or hygienic conditions of use, or simultaneous installation with the erection of a building and a reduction in the "cutting away" of building structures. Others combine a number of these advantages, and each entails special consideration if they are to be employed to the best advantage in given circumstances.

TABLE IV
APPROXIMATE RELATIVE FRONTAL AREAS OF DIFFERENT TYPES OF
SPACE-WARMING APPLIANCES (HOT WATER)

Type of Appliance		Relative Frontal Area
Ceiling, Wall and	Low Temperature	100
Floor Panels	Medium Temperature	75
2 in. dia. Pipe Coil at 6-in. Centres		40
Wall Radiator		25
2-column Radiator		18
4-column Radiator		10
6-column Radiator		7
Convector Radiator		17
Unit Heater	Low Air Velocities	0.7
	Medium Air Velocities	0.5

In considering the application of these appliances to obtain the transmission of a specific quantity of heat, the size of the appliance necessary will vary according to differences of temperature and methods of transmission. The third dimension of an appliance—its depth or forward projection—is often of secondary importance to its frontal area when applied to a building, owing to the former's smaller variation. But the latter's greater extensibility is frequently

of some consequence in the provision of the superficial area required for its accommodation. In order, therefore, to gain some impression of the variation that occurs in the facial expanse of appliances according to their functions, reference should be made to Table IV, which shows the approximate relative frontal areas of different types when transmitting similar quantities of heat.

The table is also significant in emphasizing the wide variation obtainable in the disposition of heating surface, with its effect upon the equable distribution of warmth. This is often a factor of particular consequence in deciding the type of appliance to be installed in different classes of building.

2. Heaters. Appliances that come within the range of heaters may be defined as those that transmit heat almost entirely by convection, relying upon various features for the more positive inducement of air flow over their heating surface. Amongst these may be mentioned the position occupied by the heater in relation to the floor level, the encasement of the heating surface, the passing of air through the heater direct from the external atmosphere, and the mechanical propulsion of the ambient air through the heater.

The simplest form of heater is the pipe coil which, to be fully effective, is positioned near the floor, where the lowest air temperature prevails to create the greatest temperature difference. The maximum heat transmission is produced by the more rapid circulation of air over the coil surface as a result of these conditions. The coil may be used to advantage where appearance and space requirements are unimportant, as in industrial buildings, and also for commercial and domestic purposes when it can be easily accommodated and its presence rendered unobtrusive.

The coil can be used for such purposes as airing linen cupboards, forming clothing drying rails in utility rooms and bed pan warming racks in hospitals, and serving as foot rests and warmers in front of bar counters. Its installation in shop windows is a means of reducing condensation on the glazing, and when run through a bedroom it will often temper the air sufficiently to ensure a reasonable degree of comfort. A coil of pipe under lantern and skylights, or at clerestory level in churches, will mitigate down-draughts from the glazing above—and one of the few exceptions where coils at high level are fully effective.

A proportion of the heat required in the factory class of building may be obtained from overhead coils to counteract down-draughts due to excessive roof heat losses.³ The disposition of the entire heating

surface in the form of coils at this level increases the amount of surface otherwise required, owing to reduced transmission and the bulk of the heat transmitted remaining at high level. This results in excessive fuel consumption and increased installation costs.

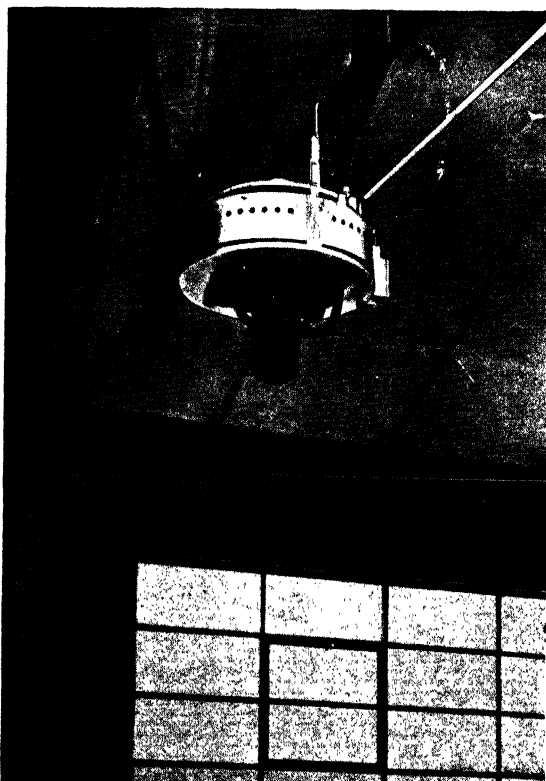

FIG. 8. GAS UNIT HEATER
Flueless gas-fired type unit for suspension.
(Keith Blackman)

Although the pipe coil is now being superseded by other forms of heating appliance for general use, it continues to serve many useful purposes when circumstances render it specially adaptable to fulfil particular requirements.

The unit heater is a type of appliance that relies for its functioning upon mechanically induced air currents passing over its heating surface, which, on this account, is arranged in concentrated formation. The heating elements are usually constructed of tubing embodying

some form of finning through which the air is forced by a fan driven by an electric motor, steam turbine or other form of motive power. The heater is arranged for standing on the floor, fixing to the wall, or securing at high level according to its particular type and the conditions under which it has to operate. Two of the latter types are shown in Figs. 8 and 9. Floor types may be arranged with the air discharging through either the top or bottom of the cabinet.

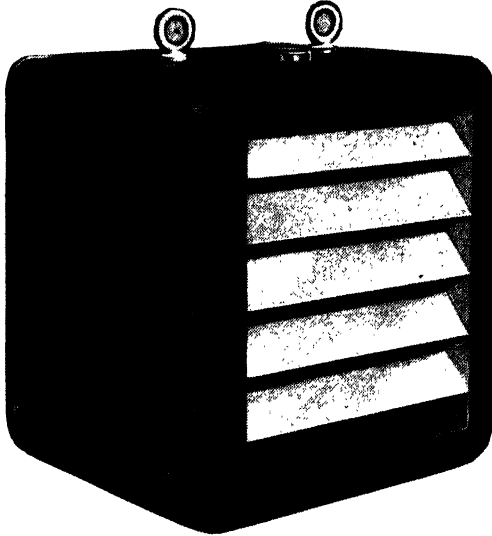

FIG. 9. UNIT HEATER FOR STEAM OR WATER
Suspended horizontal discharge type unit.
(Flexaire)

The unit heater has been produced with the main object of effecting a saving in the purchase cost of the heating installation. This is ensured by a reduction in the quantity of material used, and by a saving in the labour entailed in the fixing of the required amount of heating surface as its compact form necessitates a smaller number of appliances. A saving in floor and wall space can also be made, which is often of some consequence in the industrial class of building in which this appliance is most extensively used. When assessing the extent of the saving in its initial cost in comparison with other types of appliance, allowance must be made for the cost of electric wiring to fans unless these are driven by steam or existing shafting.

The heater is a type of appliance that must be installed judiciously

if it is to give the service to be expected, demanding care in such features as the location of units, air distribution and stream temperature, control and permissible noise. The correct position is near floor level so that it may be as thermally effective as possible, but this is usually difficult to arrange except in those buildings which are unusually spacious, and will permit the intake and discharge of air from the unit at low level without adversely affecting the occupants. The alternative position is at high level on the wall, or in the roof, in which circumstances particular attention must be given to its actual level in relation to the discharge velocity and temperature of the air. This precaution, although necessary because of air buoyancy, will not, however, completely avoid the ultimate effect of producing large quantities of convected heat in concentrated form, which is similar to that produced by overhead pipe coils and for reasons already explained is not entirely satisfactory.

The temperature gradient produced by an overhead unit heater may be as high as one degree for each foot of elevation and it is evident that this large proportion of cumulative heat at high level must be dispersed below if full advantage is to be taken of the heater, which means more positive re-circulation of air from the one level to the other. To assist re-circulation the provision of air ducting is necessary from the intake of the unit's fan to a position near the floor. Ducting, taken from the fan intake of units situated near external walls and roofs and carried to the outside of the building, may also be embodied for the provision of ventilation. (See Fig. 79.)

Convactor radiators differ from the orthodox type of radiator inasmuch that they embody some means of accelerating the normal flow of air over their surface in order to increase the emission of heat. When radiators are fixed against external walls this can be achieved by the provision of an air inlet opening in the wall behind the radiator, and the fixing of baffle plates to its sections. An encased radiator is another form of convactor heater, when the heating surface occupies the lower part of its casing. With its surface so positioned, the upper portion of the casing acts as a "chimney" increasing the circulation of air over the heating surface through openings in the bottom and top of the casing. With such arrangements as these the transmission of heat can be increased by as much as one third of that of an uncased and unventilated radiator.

Fig. 10 shows one type of convactor radiator element with a suitable cabinet, and Fig. 11 shows a method of installing another type of convactor.

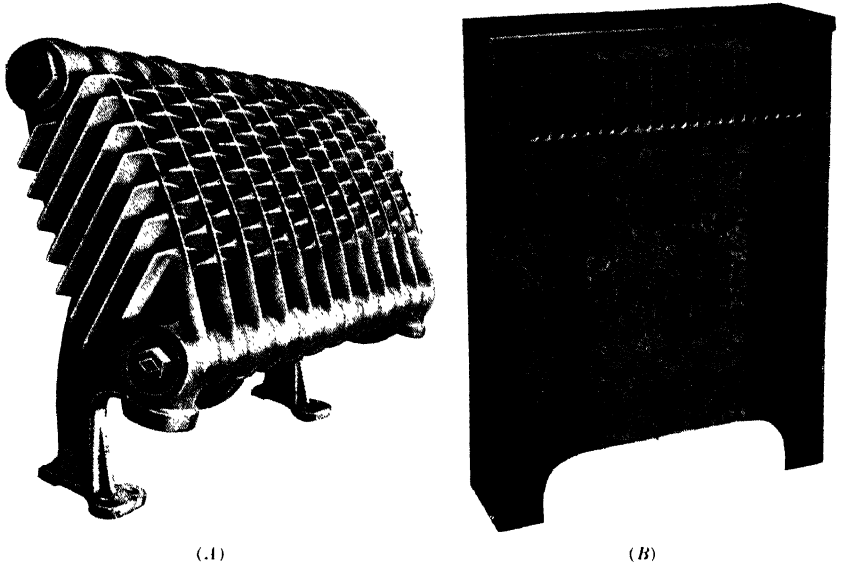

(A)

(B)

FIG. 10. CONVECTOR RADIATOR

The heater (A) may be concealed in a decorated cabinet (B) or behind structures of marble, polished slate, plaster-board, plywood, etc.

(Crane)

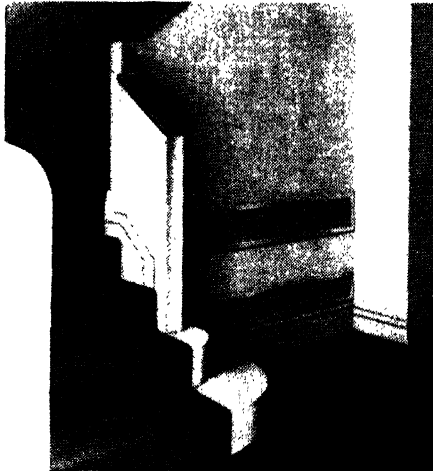

FIG. 11. CONVECTOR RADIATOR

A method of concealing a heater in the space below staircase to provide convection heating through the grilles shown.

(Vectair)

The encasement of a radiator as described can certainly serve the dual purpose of rendering the appliance more attractive in appearance whilst increasing its thermal output. The casing also reduces the discoloration of paintwork and other finishes in its immediate vicinity owing to the warm air, when leaving the radiator through front openings, being deflected in a forward direction. It is doubtful, however, if these features are of sufficient importance to outweigh the disadvantages that may result hygienically. Encased radiators are not always easily or readily cleaned and they consequently harbour accumulations of matter that would not be tolerated with radiators exposed to view. It is such circumstances as these that have largely contributed to the decline in the use of encased pipe coils and certain types of ventilating pattern radiators.

It must be conceded that the radiator, despite its disadvantages in comparison with other types of heating appliances and systems of warming, is still predominant in nearly every class of building. Its survival of the changes made during recent years is due partly to its improved appearance, partly to the fact that old customs are not readily dispensed with in this country, but mainly to its lower installation cost.

It has been mentioned that the term "radiator," when applied to what is usually regarded as this form of appliance, is a misnomer. This will be readily appreciated when it is stated that of the total quantity of heat emitted by a radiator, less than one-quarter is in the form of radiation, the remainder being transmitted by convection. The deficiency in radiation is due to the juxtaposition of the columns of heating surface.

The column radiator, which is representative of this type of appliance, is constructed, as the name implies, in the form of a number of vertical metal waterways, connected together in sectional formation and capable of extension in number as and when required. The number of columns in each section varies from one to eight, from the single column hospital pattern to the window pattern of maximum depth. With the exception of the window pattern, the radiator usually increases in height in multiples of six inches, and is either provided with feet or supported on wall brackets. Radiators of this description are made of cast iron, copper and steel, the latter material owing to its lighter weight and strength affording greater ease of installation.

It is customary to position radiators below windows for greater diffusion of warmth and to counteract down-draught from the

glazing which, unless neutralized in some way, can cause discomfort to those in its near vicinity. This position also diminishes the blackening effect on decorations caused by thermal precipitation which occurs when radiators are fixed adjacent to wall and other surfaces. These two factors are considered of sufficient importance to warrant the small extra amount of heat required to compensate that lost through the building structure, by positioning the radiators close to the glazing.

The position of a radiator should be such as to ensure that a free circulation of air occurs over its surface. In the event of its having to be otherwise positioned, as in a recess, compensation must be made for the restricted air circulation, by an increase in the radiator's heating surface. The height of a radiator will also affect temperature distribution, and those with low dimensions should accordingly be selected when space permits.

Discoloration of surfaces above a radiator fixed in a position other than below a window may be much reduced by providing a hood or shelf above the appliance, but this is not always a satisfactory arrangement from the point of view of appearance. The alternative precaution is a casing with bottom and frontal openings only, but this, if restricting the flow of air over the radiator, necessitates an increase in its heating surface to avoid loss in heat transmission.

3. Radiators. Wall pattern radiators, which are constructed of a number of single columns provided interstitially with or without metal, are also fixed in sectional formation. With a height varying from about 12 to 30 in. and a depth of about $1\frac{1}{2}$ in., this pattern of radiator is particularly suitable for fixing to the wall or any other vertical surface that may be available for the purpose. Its small projection from the wall also renders its use of value in residential buildings of moderate size when floor space is at a minimum. A typical pattern of this type of radiator is shown in Fig. 12.

Owing to its small depth, the wall radiator, as compared with the standard column radiator, requires a larger extent of wall surface for its accommodation, which may be either horizontally or vertically according to the surface available for fixing. The radiator may be also conveniently used to form a dado. The additional area necessary on account of its reduced depth, in addition to conserving floor space, affords a better distribution of heat since transmission is not confined within the same limits as those of the ordinary radiator, and for the same reason the proportion of radiant heat is greater.

The convector radiant radiator provides a larger proportion of radiation than those appliances so far described (with one exception) owing to its frontal surface forming a continuous expanse of metal and thus presenting a greater effective radiant area within similar dimensions. The exception is the wall radiator, with metal interstices between the columns which is fixed clear of the wall surface and which, under these conditions, comes within the category described. The

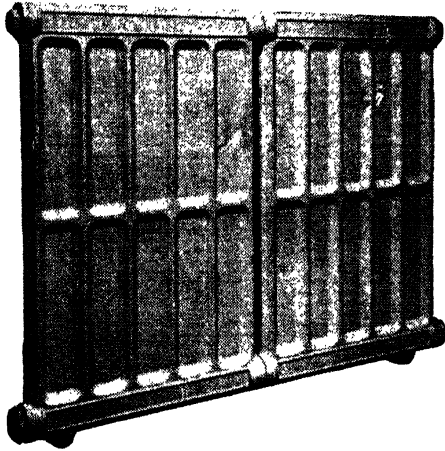

FIG. 12. WALL PATTERN RADIATOR
(Crane)

dimensions of convector radiant appliances are similar to those of wall radiators in general, and it is assembled in the same way.

An alternative type of convector radiant radiator to the wall radiator type is one that comprises a plain frontal plate with a ribbed back, to provide supplementary heating surface. It is constructed for building into window and other recesses, or to abut against a wall, or for independent fixing, in which case it is provided with a rear casing. In addition to the radiant and convective heat transmitted from the front of the radiator, air that passes up behind (from an opening along the bottom of the front plate) is warmed and flows out through a similar opening at the top of the appliance.

This type of appliance is also constructed with a gas or electric fire in the radiant frontal plate as illustrated in Fig. 13, so that it may be used for basic or "background" heating, with supplementary warmth provided by the fire to produce the final temperature required.

Convector radiant radiators minimize the amount of floor space required for accommodation. They are of pleasing appearance and when installed with concealed pipe connections and control valves can be made unobtrusive. The top of the appliance in some types being readily detachable little difficulty need be experienced in keeping the interior clean. Appliances of this description may be

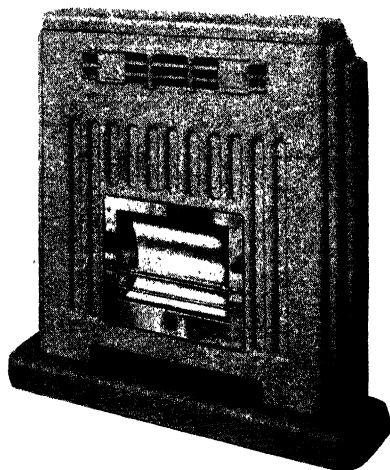

FIG. 13. CONVECTOR RADIATOR

This appliance, which consists of a hot water radiator and an electric or flueless gas fire, provides both "background" and "topping up" warmth.

(Ideal Firerad)

regarded as a compromise between a radiant panel and the orthodox radiator since they function in an intermediate manner and provide advantages somewhat similar to these two appliances.

4. Radiant Panels. The advent of the radiant panel may be regarded as significant of the trend of modern heating, that is to say, of a closer understanding of the practical application of the principles involved in the scientific distribution of warmth. Its evolution has produced a method of warming in conformity with both the physiological and psychological needs of the present age, and its use has contributed to both the æsthetic and hygienic perfecting of internal architecture.

The distribution of warmth must pervade the senses unobtrusively to ensure favourable reception, and the closer, therefore, its emanation resembles natural conditions, the greater will be the culmulative effect produced. This may be regarded as one of the fundamental causes of the introduction of the radiant panel, since it produces a

direct and indirect warming effect similar to the solar radiation of heat but with controlled intensity.

The radiant method of warming in general makes possible a less oppressive atmosphere than that of convective heating as the individual, benefiting from the effect of direct radiation, can be comfortable with a lower air temperature than is otherwise necessary, enabling extra ventilation to be provided. Moreover, little temperature stratification of the atmosphere occurs under these conditions. These two features, it is claimed, together with the lower heat loss through windows due to the absence of radiators below them, conduces to more economical operation of the installation. There is a smaller overall rise in air temperature and a reduced transmission of heat through the building structure.

It should also be remembered that certain types of panel, in directly heating the building structure itself due to the conductive effect produced by their contact with the building fabric, result in a more equable distribution of heat throughout the building. This is an advantage which can, however, be offset by an increase in the amount of heat lost through the building structure unless effective thermal insulation is provided where panels are in contact with external walls or flat roofs.

Where a building has its interior surfaces heated by low temperature panels, either exposed or concealed within the structure, the heat is distributed at reduced intensity and increased uniformity. These two factors vary in actual effect according to the extent and location of the surfaces heated. The greater the area utilized as heating surface and the greater its dispersal throughout the space to be warmed, the nearer will the atmospheric conditions attain to the ideal.

In the allocation of panel surface within a building, the area and location to be occupied, governing as they do the effective distribution of warmth, should be such as to ensure that full advantage is taken of the structural areas available. Ideal conditions would be assured by utilizing the surfaces of floors, walls and ceilings together, but practical and economic circumstances rarely permit of such a combination, and under average conditions of use, a combination of two of the three surfaces, or the use of one only, is found to be effective.

When selecting the position to be occupied by the panels on or within a particular interior face of a building, its relation to this face in terms of area is of importance according to the class of building concerned. Thus, for example, if it is decided to utilize the floor

as a medium for the transmission of warmth, it may be desirable to use its entire area or only those parts which will be known to prove the more effective in given circumstances.

In the practical application of panels it is necessary to consider their positions as affected by the class of building to be heated, as these will be partly determined by the nature of its subsequent internal partitioning, fixtures and fittings. The positioning of ceiling and floor panels, for instance, must be such that any re-allocation of floor area to form compartments, after the panels have been installed, will not deprive any one room in the building of its full quota of heat. As no obstruction may be placed in front of a panel it is also necessary to ensure that the position chosen allows for the installation of any essential fixtures, fittings or furniture without impairing its efficiency in any way. These provisos may restrict the application of panels to the surface of the floor or wall or to that of the ceiling, and it may be found advantageous to use the surface of fixtures or any other surfaces that may be adapted for the purpose.

There is evidence to show that one surface of a building's interior can be more beneficial than another for the functioning of panels, provided that the area or temperature of the panels is commensurate with the selected position. Any advantages that might be gained in this way may, however, be offset in their practical application by difficulties in accommodation or obstructed radiation. There is, for instance, some reduction in radiation from panels fixed in a vertical position and in a floor. When they are positioned in ceilings the need for ventilation is emphasized owing to reduced convective air currents.

The ceiling is most often used because in this location no obstruction can be offered to the heat rays emitted, as may occur with walls and floors. In the floor position, however, more heat is provided for the same area and surface temperature, greater air movement is created, and their use need not be prohibited by low ceiling height but only by the free floor space available as panel surface. Greater comfort may also be ensured as it is particularly important that floors should not be cold. When floor coverings are used, these generally have little effect in diminishing the amount of heat transmitted. For residences, floor or low level wall panels are to be preferred to those in the ceiling as a means of providing the full heating requirements.

Since concealment is one of the outstanding features of panels, they are eminently suitable for buildings of superior interior design

and finish. Not only is the prosaic avoided, but the absence of radiators gives more space and freedom in architectural treatment. The panel's flexibility of application has made it suitable for domestic, commercial and industrial buildings of various descriptions, and there appears to be little restriction to its general use except that of cost. The initial cost of the apparatus and the cost of installation, including the incidental builder's work involved, are both greater for concealed panels than for other types of space-warming appliances.

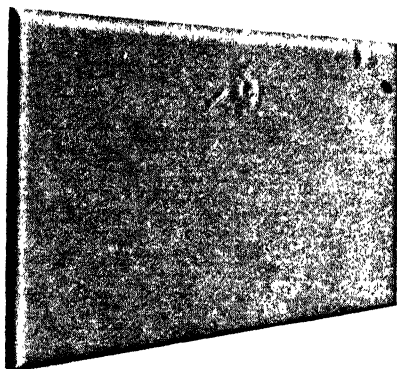

FIG. 14. RADIANT PANEL
Cast-iron panel of the superimposed type.
(*Ideal Rayrad*)

This may be regarded as insignificant, however, when considered in relation to the advantages gained in other respects.

Superimposed panels, one type of which is shown in Fig. 14, are constructed so that they may be fixed direct to any finished surface of a building, including suitable unfinished recesses preformed or otherwise available for their accommodation. The panels have a face plate with waterways formed at the back, and may be constructed with these components detachable or comprising a single unit. They are made of cast iron and assembled in a similar manner to the wall pattern radiator, with exposed or concealed pipe connections. Other types are made of steel with specially sectioned waterway tubing, housed between a carrier and face plate, and cut to required dimensions ready for finishing coats of paint when fixed in position. They are also constructed in the form of a shallow metal tank similar in appearance to a narrow welded steel radiator but with a plain flat surface.

The chief methods of application of superimposed panels are to

form part, or the whole of finished surfaces of ceilings, walls and supporting columns, as a cornice or substitute for skirtings, and as the finishing surface of recessed wall spaces below windows or

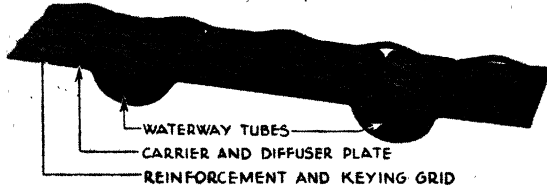

FIG. 15. RADIANT PANEL
Steel panel element of the interposed type.
(Solray)

between stanchion casings. Both flat and curved surfaced panels may be used to conform with special architectural features. Steel casements embodying the panel may also be made as one complete unit.



FIG. 16. CHURCH WARMED BY FLOOR PANELS OF THE INTERPOSED TYPE

The interposed type of panel is designed for fixing between the main building structure and its finishing material, and is used when it is desired to conceal the appliance without embedding or casting it in situ with the main building materials. It may be positioned

within the building structure but independent of it, as in the space below a floor or, more usually, in contact with the structure.

The panel may contain tubing positioned between a carrier plate and expanded metal to which the finishing material is keyed,



FIG. 17. LIBRARY WARMED BY PANELS FORMING THE ROUNDED ENDS OF THE BOOKCASES

(Reproduced by permission of the Royal Institute of British Architects)

as shown in Fig. 15, or it may consist of tubing precast in units of building material ready for the application of finishing materials. Panels of the type shown in Fig. 14 may also be used. In each case the panel may be fixed independently of the erection of the main building fabric, in sections convenient to the progress of general construction.

Owing to its concealment, increased scope is offered to the use of an interposed panel as part of the underlying structure of most

interior surfaces of a building. Areas additional to those to which superimposed panels may be fixed can, therefore, be utilized. These include the entire floor surface or part only, in the form of a border adjacent to the skirting, and also stanchion covers, window reveals,



FIG. 18. CORRIDOR WARMED BY WALL PANELS OF THE SUPERIMPOSED TYPE

counter fronts and similar fixtures, where a metal finish is undesirable. The finishing material used to cover the panel can be made to harmonize with the surroundings and includes plaster, glass, marble, terrazzo, tiling, and parquet flooring blocks.

The embedded panel is manufactured ready to form an integral part of the main building structure, by being cast in the concrete of floors, walls and other parts of a building as construction proceeds. It may be embedded in the plaster finish of the structure. Precast beams, stanchions and floor slabs may also contain the warming coils which can be made to form the whole or part of the reinforcement. The panel is generally constructed of small diameter, ferrous or non-ferrous metal tubing as a continuous jointless coil, but may also take the form of a grid when fixed vertically. Non-ferrous metals

cannot be used as reinforcement. When high water temperatures are contemplated the tubing is encased in a split sleeve of asbestos cement to allow freedom for expansion and contraction.

Application of the embedded panel can be varied in much the same way as the interposed type by being made to utilize the surfaces of ceilings, walls, floors, staircases, and in fact any surface composed of concrete, plaster, marble slabs, tiles or similar material.

The effect produced by the different types of panel on the temperature of the building structure is not altogether similar. With the interposed and embedded types, for example, more heat is absorbed by the building fabric owing to increased thermal conductivity as compared with that which occurs with the panels superimposed with an insulated backing upon the structure. This increased warming of the building itself produces some time lag in temperature changes although in general this has little effect upon conditions of comfort when counteracted by adequate means for automatic control. It does, however, emphasize the need for thermal insulation of panels in flat roofs or external walls to avoid the extra heat loss that otherwise occurs.

Each type of panel can be rendered invisible, and the practicality of using one type or the other depends largely upon the constructional details of the building, its use, and the cost to be expended upon the installation. The use of the superimposed type in existing buildings is facilitated by the small amount of disturbance caused in fixing. Some different applications of panels are shown in Figs. 16, 17, and 18.

HEAT CIRCULATING SYSTEMS

1. Alternative Methods. The method to be used to convey the heat available in the boiler house to various points throughout a building must first be considered in relation to the general requirements of the building concerned. When this has been done the various features implicit in its working require investigation to ensure that the method is wholly appropriate for the service required. A true assessment of the relative merits of the different systems, for any particular service, cannot, therefore, be made unless the circumstances in which they will be called upon to function are first known in some detail. The following information, based upon generally accepted principles of heat utilization, is given so that it may be considered in relation to specific requirements.

The use of water or steam in space heating appliances, or the circulation of clean warm air otherwise untreated, does not always provide an ideal state of atmosphere, although in the majority of circumstances each has been found satisfactory. As the temperature of air increases its relative humidity diminishes, and so, as a heating system raises the temperature of the atmospheric contents of a building its original relative humidity will be reduced considerably. The effect of this change is occasionally shown by the dryness of the air in centrally warmed buildings, but it is not always apparent on account of certain incidental influences. Such circumstances, however, cannot be expected to produce a desirable atmosphere under all conditions; the latter can only be assured by a more comprehensive treatment of the air.

In large buildings it is often found desirable, to install a combination of systems in order to fulfil the particular requirements throughout a building. It may be found necessary, for instance, to provide a system for the complete conditioning of the principal apartments, a combined invisible warming and ventilating system for the rooms of secondary importance, and perhaps an ordinary radiator system for the remainder of the building. At the same time a steam system may be required for primary service to air heater batteries, calorifiers, cooking appliances, and for other purposes.

It is generally acknowledged that, for all classes of building which

confine the occupants within a relatively restricted space, such as residences, offices, hotels, schools, hospitals and similar buildings, a system circulating a low temperature heating medium is essential to ensure satisfactory conditions of comfort. Radiators or panels of high temperature may not only prove to be a source of annoyance to those working in their near vicinity owing to the intensity of heat, but are liable to create an unpleasant atmosphere peculiar to the use of high temperature heating surfaces. The cause of this atmospheric vitiation, which is of an odorous nature, is attributed to the carbonization of organic matter deposited on the heating appliances and piping overnight, or at times when appliances have been turned off during the daytime. Such unpleasantness can be avoided by a lower surface temperature.

The various media and systems used for the circulation of heat may be classified as follows—

Water. At low, medium and high pressure or temperature, with natural and forced circulation.

Steam. At sub-atmospheric, low, medium and high pressure, including vacuum and vapour systems, with natural and induced circulation.

Air. With or without controlled humidity, with natural and forced circulation.

Each of the above methods possesses some distinct advantage of its own in regard to overall efficiency, economy in installation or operating cost, adaptability, flexibility, maintenance and other features, and the ultimate choice of one or the other must depend upon the importance attached to one or more of these features in relation to a particular class of building or service required. This will become more evident in the description dealing individually with each heating medium.

Some indication of the variation in sizes and weights of circuits involved with the use of different systems is given in Table V.

Various types of circuit, or combinations of different types of circuit, may be used in conjunction with the systems to be described. Whatever the arrangement may be is of little concern. Provided the design of circuits conforms with recognized scientific methods, and they are also correctly installed and balanced in practical use, the efficiency of the systems will remain unimpaired.

It is sometimes thought for example, in connection with the use of hot water, that insufficient heating results from appliances situated at the end of a one pipe circuit on a ground floor or, for that matter,

TABLE V
 APPROXIMATE RELATIVE SIZES AND WEIGHTS OF CONDUITS
 ACCORDING TO HEAT TRANSMITTING MEDIA USED FOR SIMILAR QUANTITIES

Heat Transmitting Media		Dia. of Pipe or Duct. in.	Superficial area sq. ft. per ft. run	lb. Weight per lin. ft.
Steam	Low Pressure .	3.0	0.89	7.54
	Medium Pressure .	2.0	0.62	4.52
Water ¹	Low Temperature	2.5	0.78	6.37
	High Temperature	1.5	0.49	3.54
Air	Normal Pressures .	30	7.85	16.40

from appliances at the end of a two pipe circuit on a top floor. It is believed that the efficiency of such remote radiators or panels is prejudiced on account of their distance from the boiler house, and that this defect is a natural result. It must be admitted that instances have been known to occur where appliances in such positions have proved unsatisfactory, but not because of their location, only because of faulty design or installation of the apparatus.

To ensure that appliances will function with equal efficiency, irrespective of position, is simply a matter of attaining a correct relationship between capacity, motive force and temperature. Provided that the capacity of the mains and subsidiary circuits has been computed to pass the required quantity of water or steam at the correct temperature or pressure against a calculated resistance to its flow, and in a specific period of time, and that the amount of heating surface of the appliances has also been based upon a pre-determined temperature of the medium circulating through them, there is no reason to suppose that the appliances will be in any way ineffectual on account of their position. Functionally, there is no limit within a building or area of a site to the distance an appliance may be located away from its source of heat supply, although, economically, certain restrictions must be imposed. Similar provisos apply to space warming from the remote registers of air systems.

There are, of course, other features in the use of circulating systems which necessitate careful attention in their practical application. These include the removal of air from systems using both water and steam and the latter's freedom of flow by the removal of condensation, and provision of the proper throw of air delivered to spaces

¹ Forced circulation

from distributing duct grilles. The question of noise too, entails appropriate velocities and avoidance of turbulence in the use of the transmitting media, together with the inclusion of flexible conduit connections and possibly absorbently lined air ducts. Precautions are necessary in the transit of media through conduits to reduce the transmission of noise from power units and other machinery of the central plant, or that produced in the conduits themselves. Noise can become a nuisance in some buildings if allowed to exceed certain limits. No doubt the time is not far distant when power-driven appliances will be specified with noise ratings, which, when applied in conjunction with known properties of sound insulators, will enable the transmission of noise to be limited to the desired level.

The magnitude of noise permissible will vary according to circumstances, but in certain buildings and particularly in hospitals, cinematograph studios and bedrooms, a maximum noise level of about 50 phons may be demanded.

Whichever method is used for circulating heat, the concealment of distributing circuits within the building structure makes it necessary for early consideration to be given to ways and means, so that adequate provision may be made in planning the constructional details of a building. Horizontal pipes and ducting can usually be concealed by fixing externally on roof flats, in roof voids, in spaces between floors and ceilings, behind beam casings, above suspended ceilings and in trenches. Vertical pipes of low temperature may be fixed in the concrete cover of stanchions. Both vertical piping and ducting may be installed between stanchion cover and casings, behind false window reveals and in wall chases. Voids incidental to construction may also be utilized.

It is also important that any future building extensions contemplated should be made known at the time the main system is being designed in order to avoid subsequent difficulties in the extension of circuits and of the centralized plant.

2. Water Systems. The circulation of hot water, by gravitation or mechanical propulsion, is a method that has proved itself, under the majority of conditions, to be a satisfactory means of transmitting heat for general purposes of atmospheric warming. From the time the system was first introduced in this country some 130 years ago, its increasing adoption has been due chiefly to its simplicity of use, safety, flexibility of operation and ease of general maintenance.

Such features as these have made the system readily adaptable for

use in those classes of buildings where it can receive only a little attention from an attendant who has other duties to perform also. But the system has been equally successful in the largest of buildings where skilled attention is permanently employed for its operation, and only in exceptional circumstances can its use be considered unsuitable.

The chief asset of water as a medium of heat transmission lies in its ability to contend with external temperature fluctuations with comparative ease. Owing to the wide range of temperatures permissible with water, within the limits of the the low pressures used for general heating purposes, little difficulty need be experienced in producing whatever variation is necessary to compensate fully for climatic changes. Similarly, at the higher pressures used for industrial heating purposes, the equivalent temperature range obtainable offers greater facilities than with other media.

For the smaller building, systems that can operate with a natural gravity circulation are to be preferred to those dependent upon the use of an accelerator, since mechanical devices are liable to be neglected. This method of circulation must, of course, be used when a supply of electricity is unavailable unless power can be derived from other convenient sources.

The gravitational circulation of water is dependent upon the size and length of circuits relative to their elevation above the boiler plant, and the quantity of heat given off at their different levels. On this account a building that has a small compact ground area and is multi-storied is more favourably planned for a gravity circulation than one that consists of a single floor the area of which extends mainly in one direction from the position of the boiler house.

The actual arrangement of circuits for hot water systems will vary according to such circumstances as those described above together with the constructional details of the building concerned and the type of space-warming appliance used. A number of alternative arrangements are shown in Fig. 19, each of which may be designed to work with a gravity or forced circulation except No. 6, which relies upon the use of a pump.

It is sometimes the practice to compromise in the design of a system so that it may work partly by gravity, pumping of the water being relied upon only to deal with extremes of temperature. In this way the system is enabled to function during the greater part of its working time without the use of a pump, the latter being called upon only during periods of severe cold weather. In recent years

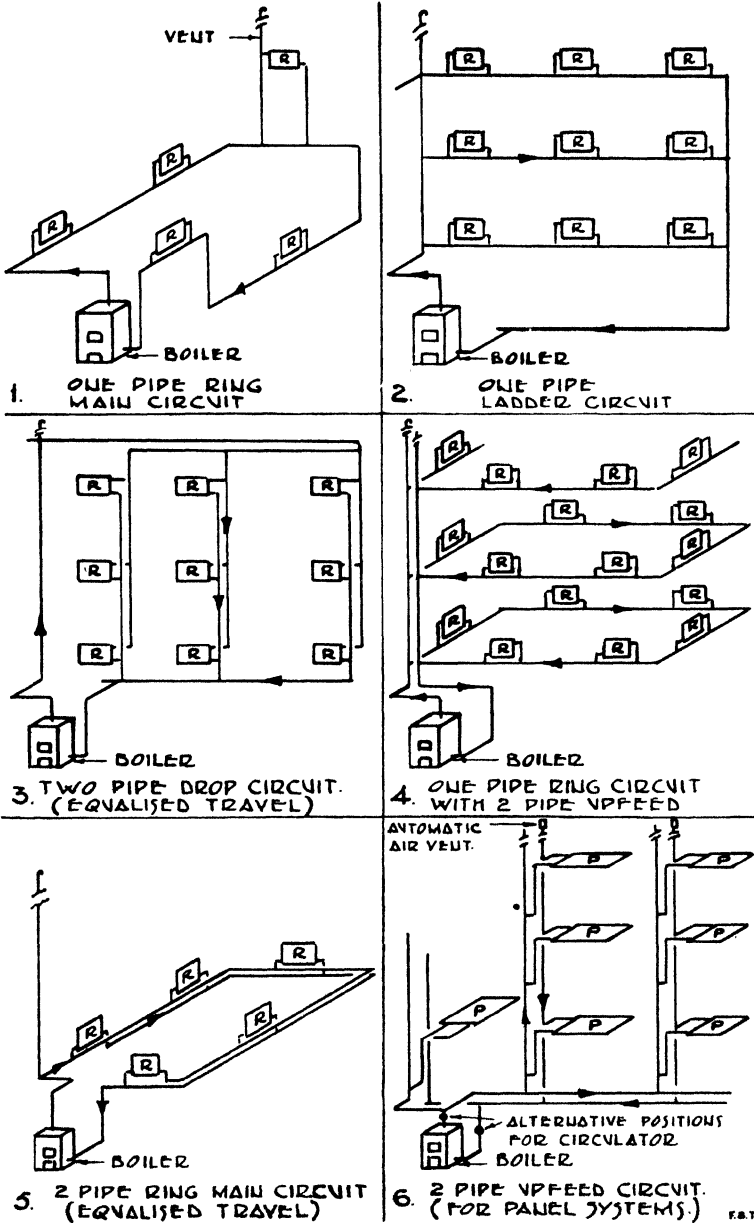

FIG. 19. HOT WATER CIRCULATING SYSTEMS

Each system functions with natural or forced circulation except No. 6, which depends upon the use of a pump.

the tendency has been for forced circulation to supplant the use of gravity in larger buildings in order to minimize thermal losses from the ineffective heating surface of circuits, react more quickly to sudden changes in external temperature, and provide more equable temperatures for space-heating appliances, and at the same time facilitate the installation of piping by affording a reduction in its size and thereby minimize the space required for its accommodation and concealment.

The basic working temperature of the water circulated through a system will be governed by the type of heating appliance used, and the class of building the system is to serve. Low temperature systems require a mean temperature throughout the apparatus which may need to be only a little above that of bodily heat to provide adequate warmth, when working in conjunction with radiant panels. Higher temperatures may not only cause cracking of plaster when this material is applied as a finish to the panel, but will not create the same diffusion of warmth, and it is evident that such temperatures must not be used for panels that extend over the entire surface of the floor. Flow temperatures not exceeding 200 deg. F. are commonly used for radiators and heaters, and may also be employed for exposed panels and those covered by materials other than plaster when their location permits of a higher temperature.

Medium and high pressure systems, which operate up to temperatures in the region of 350 deg. F., may be used for heaters, radiators, and certain types of exposed radiant panels. This class of system is one that is employed principally in the larger industrial class of building, where the effect of high temperature heating surface cannot be detrimental in any way, but affords in addition to other advantages, an appreciable reduction in the amount of heating surface to be installed as compared with systems of lower temperature.

Steam for manufacturing processes and other purposes can be made available by this system at any point adjacent to the run of hot water circuits by the connection of a steam generator, without entailing the disadvantages sometimes associated with the use of steam in general for heating purposes. Since in its operation and general maintenance, this system provides similar advantages to those of hot water systems in general, it will doubtless be more extensively used in the future for industrial heating purposes.

3. Steam Systems. The use of steam, for the conveyance of heat, provides an alternative medium to water that is advantageous in

certain circumstances, and one that is essential for the services provided by central heating in its wider application. When used solely for the purpose of atmospheric warming in non-industrial buildings there is little to be gained except where it enables advantage, to be taken of the benefits derived from sub-atmospheric or differential systems as described later.

As a primary medium for service to calorifiers to provide indirect heating and hot water supply, and for use in unit heaters and heater batteries for warm air and complete conditioning systems, steam is found to be beneficial in certain respects. It enables economies to be made in initial cost and space, reacts more readily to sudden demands for heat, and overcomes circulation difficulties. It has also been known to solve such problems as the deteriorating effect of condensation that occurs in tubular boilers with low temperature hot water.

For such purposes as laundering, cooking, sterilizing, disinfecting and special process work, steam must generally be available, and this consideration is often the reason for its general use throughout a building. The generation and distribution of steam, however, owing to the characteristics of this form of heating and power agent, necessarily involves additional and more complicated equipment as compared with hot water. On this account the operation and maintenance of the plant are more exacting. These factors, together with others later described, tend to confine the use of steam systems to larger buildings where proper supervision can be made available.

Exhaust steam, which is frequently the cause of much wasted heat when discharged direct to the atmosphere, is an instance where atmospheric warming may be provided from a source of supply already available without impairing the efficiency of the heating service required. By transferring the heat available in the steam to water, similar advantages can be obtained to those normally existent in a low pressure hot water system. Such an arrangement as this is shown in the bottom diagram of Fig. 20, which illustrates some of the different lay-outs of equipment for use with steam.

Multi-storied buildings of extensive elevation in countries with colder climates have influenced, to a great extent, the use of steam systems owing to the advantage gained where additional height and heat are concerned. This is because, with the use of water, the high pressure produced within the apparatus at its lower levels, due to the considerable static head created, can be eliminated, and the size of appliances reduced as a result of the higher temperature

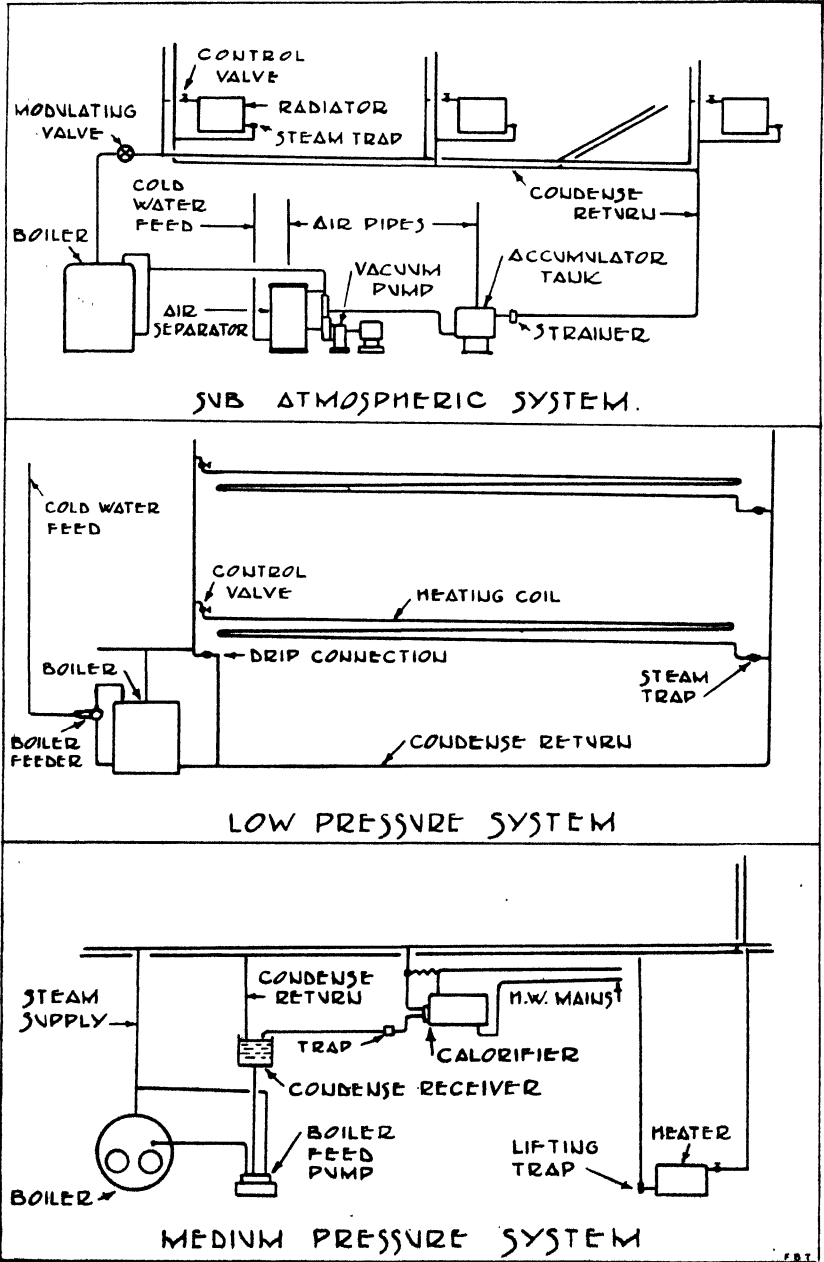

FIG. 20. STEAM CIRCULATING SYSTEMS

provided with steam. Methods originating from these circumstances have resulted in the introduction into this country of certain types of steam systems, but it has been unnecessary to take full advantage of them because of restrictions imposed in regard to the maximum height of buildings permissible, together with the warmer climate.

Systems operating with steam entirely at "gauge" pressures, other than the vapour system, cannot be expected to function effectively for atmospheric warming at all times, owing to the comparatively inflexible nature of this medium under average conditions of use. Apart from the objections to high temperatures in certain classes of building, the impracticability of frequently altering the pressure of the steam, to vary its temperature and compensate for climatic changes, is a feature that makes the system unsatisfactory under average working conditions. Heating appliances supplied in this way with steam above atmospheric pressure must either function at a temperature above 212 deg. F., or become inoperative by valve control, as there are no satisfactory intermediate stages of regulation as with water, the temperature of which is easily varied through a wide range.

An exception to this disadvantage in the use of steam at low or higher pressure occurs when it is applied to heaters provided with thermostatic control. The vapour system also permits of some degree of control since the quantity of vapour admitted to an appliance can be regulated by valve adjustment.

In order to compensate otherwise for the lack of temperature variation that occurs when steam is used above atmospheric pressure as in a convector radiator, it is necessary to control the quantity of heat transmitted from the appliance by encasing it and regulating the amount of air passing over its surface. By this means the air temperature of the space warmed can be moderated by the adjustment of a suitable regulator controlling the amount of air circulating through openings in the casing of the radiator.

The sub-atmospheric, or differential steam system, has been designed to overcome the objections to using steam at higher pressure for general appliance heating. By working mainly within a range of pressures below the atmosphere the temperature of the steam can be reduced below the evaporation temperature of 212 deg. F. at atmospheric pressure, enabling a temperature variation to be effected similar to that of hot water systems.

Steam, when available for distribution from a conveniently centralized point, and supplied to other classes of appliance able

to utilize it effectively, is obviously a superior method of heat application to that necessitating the combustion of fuel within the appliance itself. For this reason laundry, cooking, sterilizing and disinfecting appliances, which depend upon an easily controllable supply of heat for satisfactory functioning, will respond more effectively to the requirements when supplied with heat in the form of steam.

4. Air Systems. Theoretically, the use of air as a means of heat conveyance from a centralized point leaves little to be desired in the provision of a system that at the same time may be made to include other desirable features in addition to the warming of the atmosphere. In practice, however, the system that provides completely conditioned air in addition to the supply of heat is not as extensively employed as might be imagined, considering its functional superiority over other systems. Its comparatively restricted use is due to a combination of circumstances, which include, together with less important factors, its initial cost, the space required for accommodation, and maintenance requirements.

Air systems that are designed primarily for the purpose of providing warmth alone, by the direct method (as distinct from that of warming the atmosphere indirectly by means of the building structure) are also used to a less extent than either water or steam systems. The reason for their limited use may be attributed, mainly, to the extra space required for the accommodation of distributing circuits, the necessary continuous use of a fan, the oppressive atmosphere that can be created by high initial air temperatures, and the uneconomic use of fuel. These features restrict their installation mainly to factory buildings, where full advantage may be taken of the system's low cost of installation, together with the saving made possible in floor space, and its more speedy response to demands for heat and ventilation requirements.

The chief advantage in using air as a means of warming, irrespective of humidification, is the facility with which positive ventilation may be provided at the same time, with a resulting saving in the cost of apparatus. A further advantage is gained by the use of air as an agent for the conveyance of heat when the condition of the external atmosphere makes its admission into a building undesirable without first undergoing some process of cleansing.

Air systems as far as heat circulation is concerned, may be divided into three categories according to whether they provide warm air for ventilation only,*for both warming and ventilation,

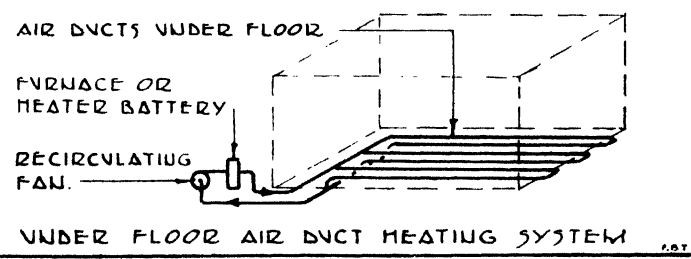
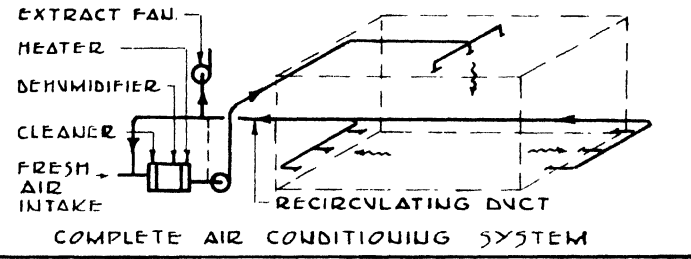
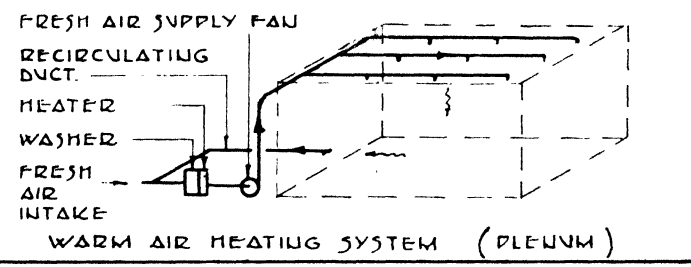
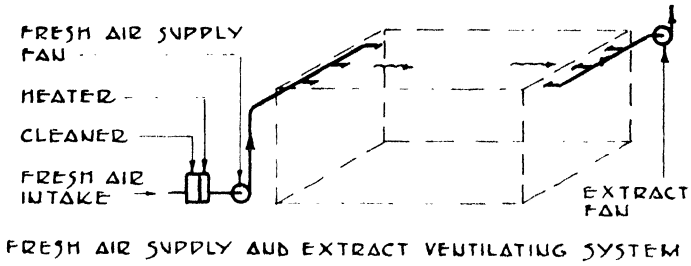

FIG. 21. Air Circulating Systems

Diagram showing alternative arrangement of circuits according to system used. (Actual position and number of air registers will depend upon individual requirements.)

or for air fully conditioned supplying both these services. In addition, a further system may be used occasionally for warming purposes only, by circulating air between the building structure to warm the atmosphere indirectly by means of the building fabric. Each of these systems is shown diagrammatically in Fig. 21, the broken lines denoting the enclosures treated.

Systems that provide ventilation only, although employing a means of heat circulation, are designed to warm the fresh air introduced into a building just sufficiently to ensure that, when discharged into the spaces to be ventilated, its temperature is approximately equivalent to that of the air in the space itself. The quantity of heat involved is only, therefore, that required to balance the loss due to air interchange. Such systems as these may be supplementary to a hot water or steam central warming system, when natural conditions of ventilating are insufficient, and they may be used to introduce a supply of fresh air only or be combined with an extract ventilating system to produce a "balanced" state of atmospheric pressure.

Air systems that provide both warming and ventilating, sometimes referred to as the plenum system, raise the temperature of the fresh air introduced above that to be maintained inside a building. The extra heat enables sufficient warmth to be provided to supplement background heating or to counteract in full the loss through the building structure and that due to the interchange of air. This latter method of warming is used chiefly in industrial buildings, particularly where some form of mechanical ventilation is required throughout the year, on account of contamination of the atmosphere by the manufacturing processes undertaken.

The system that produces fully conditioned air supplements its uses for warming and ventilating needs by providing humidification, de-humidification, and cooling. On account of its ability to control the amount of moisture in the atmosphere, this system is able to provide ideal conditions for numerous manufacturing processes, in addition to more comfortable conditions for the individual. It is explained in fuller detail in the chapter dealing with air conditioning.

Systems that provide warming by the circulation of air that is not intermixed with the atmosphere within the building, but is restricted to spaces within its structure, are usually confined to the use of floor surfaces as a medium for the transmission of the heat circulated. Such a system, which entails a modernized arrangement of the hypocausts used in Roman buildings and functions on the principles

of localized radiant warming, may be applied in single-storied buildings of considerable height where it is unnecessary and economically unsound to provide an equable air temperature from floor to roof. The classes of building to which this system is most applicable are exhibition halls, cathedrals and factories. More recent developments of this system are applied to small houses.

Each of the systems described will require provision to be made throughout a building either for the accommodation of independently constructed ducting or for its formation as an integral part of the building structure. Ductwork that is constructed independently of the building and made of metal and other approved materials may be accommodated and concealed in a similar manner to that described for water and steam circuits.

The air inlet and extract registers can be made to form part of the internal decorative features of the building, provided that it is adopting this course, the requisite dimensions of registers are in no way altered so as to affect the quantity and velocity of air passing through them.

Much of the successful functioning of air systems depends upon the proper introduction and dispersal of the air distributed, which entails correct allocation of the registers or grilles. These must be dimensioned to pass the air at appropriate velocities, and on this account no restriction should be offered to the number, size and position of the registers to be installed.

VENTILATING APPARATUS

1. Alternative Methods. To provide sufficient ventilation throughout a building and thus ensure the purity of atmosphere desired, one or more methods may be employed according to the extent of the interchange of air required and the conditions under which this is to be provided. These methods are either natural or mechanical, according to whether advantage is taken of laws governing the natural flow of air or recourse is had to mechanical propulsion for its movement.

In considering the methods available to provide ventilation, it should be remembered that there are those to be avoided in addition to those to be recommended, and the ultimate choice of suitable means must again be dependent upon circumstances. The two important factors to consider in the movement of air are its velocity and temperature, and unless these are closely coordinated in accordance with volumetric requirements, difficulty will be experienced in obtaining the desired conditions. It is, therefore, essential to select methods capable of effecting proper control of the air in order to comply with specific conditions.

Certain ventilation requirements can be fulfilled by natural means, but climatic conditions are often unfavourable for them at times of greatest need, as on days in summer when there is little air movement.

The natural circulation of air can be rendered more effective by certain appliances designed to accentuate it, but their efficiency must depend mainly upon the prevailing external temperature and the state of the wind. For this reason difficulties may be experienced in stabilizing the flow of air and consequently internal temperatures.

Despite the difficulties that may be encountered with natural methods of ventilation in the larger industrial type of building, they can however be utilized to much advantage in residential buildings. This is apparent in the effect produced by the chimney of a fireplace, which, with a coal fire burning produces an average ventilation rate of $4\frac{1}{2}$ air changes per hour with the door and windows closed. Without the fire alight and a cold flue this rate is reduced to about $1\frac{1}{2}$ changes per hour, diminishing to just over half a change with the flue sealed.

Air circulated by mechanical means is unaffected by changes in the weather, and very little by that of the wind, and can, therefore, be relied upon to provide a positive flow under all normal circumstances. This method, which offers no restriction to the volume of air used, can be made to cleanse the air circulated, in addition to providing improved distribution.

The methods available for providing ventilation, which include that already described for the circulation of heat by air in Section 4 of Chapter V, are as follows—

1. Extraction of vitiated air.
2. Introduction of fresh air.
3. Combined introduction and extraction.

Each of these methods may be used in conjunction with natural and mechanical means for the movement of air, from which it will be seen that four alternative combinations are provided when the third method is utilized. With mechanical means the methods may be applied to function by the use of fans located in the spaces to be ventilated, or positioned at some remote centralized point, according to the character of the spaces to be treated.

Mechanical extract or inlet systems working by themselves, as when only one or the other system is installed, can be made to fulfil certain needs of ventilation provided that in their application due regard has been paid to the conditions under which they will be called upon to operate. These will chiefly concern the volume of air involved, the arrangement of heating appliances, and the provision to be made for air filtration, each of which will be influenced by the class of building concerned.

The use of a mechanical system that combines the supply of air with its removal eliminates the tendency for a pronounced unequalized state of atmospheric pressure to exist within a building, such as occurs if quantities of air are either admitted or removed by only one system or the other. In the avoidance of this disparity in air pressure, more positive control of its circulation throughout the spaces ventilated can be maintained, reducing the risk of infiltration from one section of a building to another, and from outside.

Ventilating systems, in the course of providing fresh air, may be utilized at the same time for warming purposes by appropriately positioned space-heating appliances through which fresh air may be induced to enter. Alternatively fresh warm air may be supplied by what has been described as the plenum system. Conversely, as a means of removing heat, the systems can serve the purpose of cooling

the space ventilated, but only to a temperature dependent upon that prevailing externally and consistent with the movement of normal volumes of air. When additional cooling is required supplementary apparatus must be embodied or an alternative method of cooling adopted.

When an air washer is used with recirculated water as part of a ventilating system, evaporative cooling is made possible and the air can be introduced into a building at a temperature approximately that of its wet bulb which may be ten or fifteen degrees below the dry bulb temperature. Cooling by this means, however, is sporadic owing to its dependence upon the fluctuating external wet bulb temperature and is restricted for other reasons. The actual cooling obtained must accordingly be of a limited nature unless the washer spray water temperature is lowered, but the use of a washer is desirable in winter time for humidification purposes for the reason given on page 54, and because it also assists in cleansing the air.

With the use of fresh air supply systems that introduce the air mechanically in large quantities, the general state of the atmosphere prevailing externally will usually necessitate its cleansing before delivery into a building. This is necessary for hygienic reasons, to prevent premature discoloration of internal decorations, and avoid damage to manufactured goods. Alternative methods of air filtration are available for the removal of impurities as described in Section 3 of the present chapter. These appliances will vary in type according to the state of the atmosphere, the volume to be handled, and the facilities provided to maintain their efficient operation.

2. Extract Systems. The use of an extraction system by itself must necessarily be limited by its capacity, since the entry of large quantities of air through windows or doorways, to replace that extracted, will prove objectionable during winter time on account of its temperature. When a large volume of air is to be removed, the system, therefore, needs to be supplemented by heating appliances positioned in the spaces treated and arranged to warm the air on entry. Such an arrangement can be satisfactory for certain industrial purposes, but for general use it is best substituted by the provision of a complete fresh air supply system.

The extraction of moderate quantities of air by natural means is provided, in its simplest form, by the functioning of a chimney of an open coal fireplace. The draught created by the burning of solid fuel in a fireplace under average conditions of use, is sufficient, as we have already seen, to extract a volume of air equivalent to

about four times the cubic contents of a normal sized living room during one hour. The exact interchange of air will depend upon such factors as the height of the chimney, the size of fire, and the prevailing outside temperature, but the general service to be obtained by this method of air extraction makes it desirable for radiators fixed in living rooms to supplement the use of the fireplace rather than to supplant it.

The use of a flue and fireplace, when the room is heated with different types of appliance also provides good rates of ventilation in the majority of cases as the following figures testify—

Method of heating	Air change per hour
None	1.7
Anthracite Stove	0.7
Hot-water Radiator	2.0
Electric Convactor	2.4
Electric Radiator	2.7
Gas Fire	3.1
Coal Fire.	4.5

These figures are the result of tests made in an ordinary room at the Building Research Station.

The use of these appliances or the flue by itself, in conjunction with a wall ventilator or other suitable opening as may be necessary, will therefore, provide a satisfactory means of ventilation by natural methods in the majority of cases.

The natural extraction of greater quantities of air, which is required in large buildings, such as assembly halls and single-storied buildings of the factory class, can be provided by the roof ventilator type of appliance shown in Fig. 22A. This device, which under favourable conditions of use, is able to withdraw an appreciable volume of air, is mainly dependent for its functioning upon the velocity of the wind. Consequently its performance is variable and difficulty is experienced in maintaining constant temperatures in buildings which need to be warmed, but in other respects it is effective for the purpose intended.

Extraction of medium quantities of air by mechanical means may be undertaken by the use of a propeller type electric fan positioned in windows, walls and roofs, and this is effective both for intermittent and continuous use. Similar appliances may be utilized for the general ventilation of residences, by positioning them in the walls

of attics or roof spaces for the withdrawal of air through a register fixed in the ceiling at the top of the staircase.

In the provision of mechanical extract systems for buildings of medium or large sizes, an alternative to the use of independent appliances is that provided by the centralized indirect method, which enables air to be withdrawn by a single fan, from the various sections of a building, through a system of ducting. This arrangement, by eliminating a number of independent fans and reducing maintenance requirements, facilitates discharge of the vitiated air which, owing to the situation of certain rooms, may present some difficulty with the direct method of extraction.

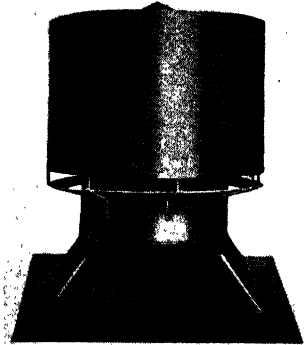

FIG. 22A. ROOF VENTILATOR
(Cellucite)

The position of the extract air registers necessary with the indirect system is normally at high level in the space to be ventilated, where the air is most highly contaminated and excessive in temperature, but the source of vitiation will sometimes necessitate a variation in this respect. In garages,

for example, where it may be necessary to provide mechanical ventilation, the extract registers may be positioned at or near the floor surface because vehicle exhaust gases remain at a low level.

The appliances used in conjunction with direct extract systems, which are principally those of the propeller type fan and electric motor, ducting and registers, are either constructed as a complete unit ready for installation or installed in sections. Complete units may comprise a fan and motor, with frame, baffles and fixing flange designed for attachment to structures in general, or the fan and motor may be housed in a metal box frame, complete with shutter and grille and motor switch ready for building into the thickness of brickwork or concrete, similar to the type shown in Fig. 22B. Alternatively, the appliance may be specially constructed complete with ducting and suitably weathered for fixing to roof ridges and in other exposed positions, and, as already seen, they may also take the form shown in Fig. 22A, which illustrates a ventilator of the non-mechanical type.

There is some variation in the type of appliances used with the

indirect system in regard to the main centralized fan and motor. The former is generally of the centrifugal pattern although the axial flow type is also suitable for particular requirements. Centrifugal fans consist of an impeller with forward, radial or backward blades housed in a metal casing with suction and delivery openings at right angles to each other. The impeller may be driven by direct coupling to an electric motor or use may be made of belts or ropes

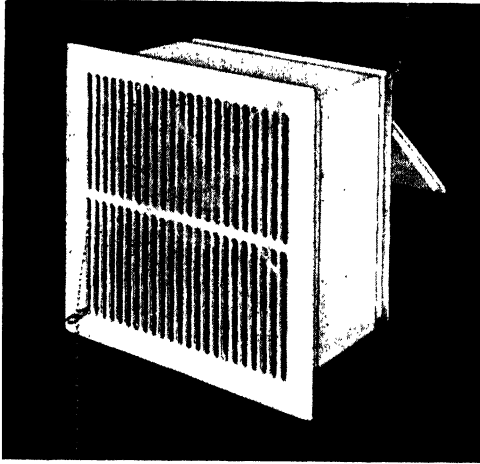

FIG. 22B. EXTRACT VENTILATING UNIT

A unit consisting of fan and motor, with external air shutter and motor switch operated by pull chain, constructed for installing in thickness of wall.

(Air Conditioning & Engineering, Ltd.)

to couple the two together. Axial flow fans comprise a propeller, with a number of blades of aerofoil design, the whole arranged to work in stages if required. The fan is usually direct-coupled to an electric motor and housed within the air duct, but it may be driven by a motor positioned outside the ducting.

Extraction systems, in one form or another, can be used in a variety of buildings. Working under natural conditions they are particularly suitable for residences, small offices and shops, boiler houses, and factories. Mechanical systems can be used to advantage in large kitchens where it is desirable to prevent cooking odours from pervading the remainder of the building in addition to ventilating the kitchen itself. They are also extensively used for the ventilation of internal lavatories in blocks of flats and offices, and in industrial buildings the system is often essential where processes are

carried out entailing the use of chemicals producing obnoxious or dangerous gases or vapours.

3. Fresh Air Supply Systems. It has been seen that the chief objection to the use of an extraction system by itself throughout the year is one of temperature, on which account the extent of the ventilation permissible must be restricted within certain limits if draughts are to be avoided. This is a deficiency which may be overcome by the use of methods which, whilst admitting fresh air, are able to control its temperature effectively. A further advantage of these methods is their cleanliness, which is provided by filtration of the mechanically introduced air.

The admission of fresh air by natural means during the milder periods of the year may, of course, be provided effectively by the use of windows and other openings. Rooms with windows on opposite sides, for example, may have as many as thirty air changes per hour, and a sash window open two inches can provide nearly two air changes each hour which is increased considerably if an outlet shaft is provided.

There are numerous devices available in the form of wall ventilators for the admission of fresh air under natural conditions. These nearly all suffer (when functioning) from the disadvantage of admitting undirected and invariable quantities of cold as well as fresh air and consequently soon fall into disuse by being kept permanently closed during the winter and becoming ultimately obstructed by accumulations of the usual assortment of matter. On this account and because wall ventilators of normal size admit little air when functioning under average external air conditions, and when means are not provided for the egress of air from a space other than by leakage, such appliances are frequently omitted and reliance placed upon windows provided with hinged, swivel and hopper type openings for the natural infiltration of air.

The admission of tempered air by natural means may be obtained by utilizing the heat available from radiators where these are installed. By the provision of fresh air inlets behind those radiators fixed adjacent to external walls, sufficient air may be introduced to fulfil all normal ventilating requirements in the residential, office, and school class of building. Despite the simplicity of this method of admitting warm air, it is not now as extensively used as formerly. This decline may be attributed to a modern aversion to fresh air in buildings, but in some cases interference with design of architectural façades may have caused its neglect, the latter providing an instance

of where compromise between architectural and hygienic ideals has not been accomplished. The use of unsuitable appliances, and also the possibility of damage to radiators by freezing due to neglect in use, may be further causes. There is, however, reason to believe that the real cause is keen competition in the selling of equipment. The prices quoted for heating installations do not include the larger apparatus entailed by the provision of fresh air inlets, and, moreover, purchasers have shown a reluctance to pay for the additional heat required to secure fresh air. Such a policy in the sale and purchase of equipment can only be to the detriment of a building, its occupants and its owner. Nevertheless, the method described is strongly recommended if full use is to be made of radiator appliances.

The introduction of warm air by mechanical means is effected in its simplest form by the use of a unit heater arranged to admit air direct into the space to be ventilated. Heat may be supplied to this appliance by electricity or gas and by its own combustion of solid fuel or oil, and also by water or steam when available. The quantity of hot water or steam supplied to the heater should be automatically controlled when these heating media cannot be easily varied in temperature at their source of supply, in order to compensate for changes in the temperature of the entering air.

The mechanical introduction of air by the indirect method, that is, by the use of a main fan and circuits of ducting, is similar to that described for an extraction system. In addition, heaters which may be both centrally and remotely located according to zoning requirements, must be provided for winter use, together with an air cleaner, if conditions are such that the latter's use cannot be dispensed with. The position of the air inlet registers forming part of this system should be near the floor level, since the natural tendency for warm air is to rise to a higher level. Arranging them in this position, however, is not usually possible. Everything depends upon the class of building concerned, the quantity of air to be dealt with, and the cost to be expended upon the installation, as air, when introduced at low level, must be discharged at lower velocities, which entails larger or more numerous registers.

The appliances used with fresh air supply systems are, in many respects, similar to those used with the extraction system. For the natural introduction of air they include the convector type of radiator, or one of standard pattern which, in some cases, will require to be fitted with baffle plates. An adjustable register of the shuttle, hinged or box type, must be fitted to the air inlet opening

through the thickness of the wall for regulation purposes when appliances do not include adjustable dampers. Registers of either the hinged or box type may be preferred as, in such cases, the baffling of radiators can be omitted. The external side of the inlet opening in the wall may be covered with a metal grille or open stonework.

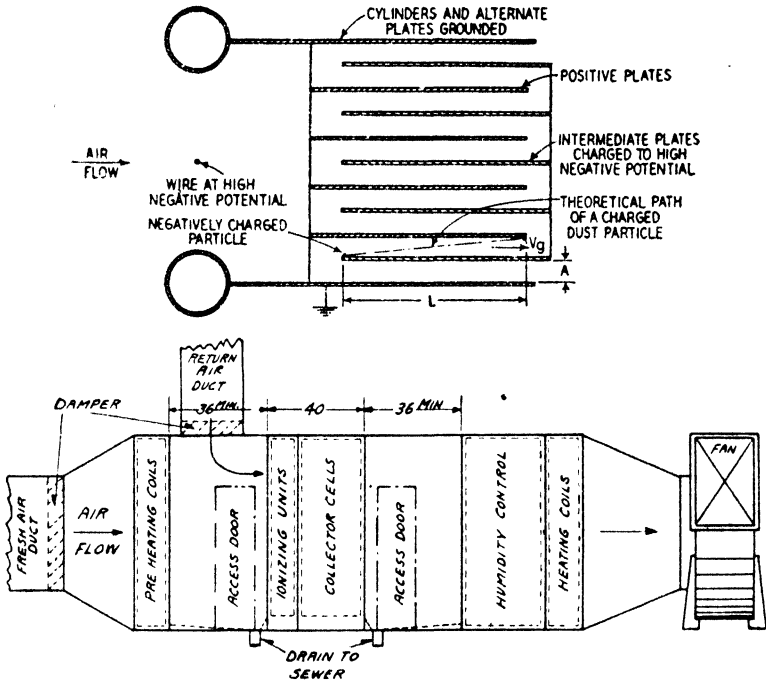

FIG. 23. ELECTROSTATIC PRECIPITATION AIR FILTER

A filter functioning on electrostatic principles for the removal of dirt particles. The upper diagram is a cross-section of the ionizing unit and parallel dust-collecting plates of an electrostatic precipitator, showing the path of a dust particle. The lower diagram shows its application to an air-conditioning system.

(“Precipitron,” Sturtevant Engineering Co., Ltd.)

Appliances for cleaning the air introduced vary in type according to the volume handled and its condition. The dry type of filter, composed of teased hessian cloth, cotton wool, serge, or other suitable material, through which the air is passed, is often installed in the smaller system, as it is the least costly and easily fitted. Other materials that may be used in the dry type of filter are glass fibre, woven wire and metal wool, the effectiveness of which will depend upon the denseness of the material employed.

The viscous type of filter, which depends for its cleansing action upon a series of metal passages of varying formation, coated with a viscous fluid for the adherence of solid matter in suspension, is installed in the larger systems when an attendant is available to carry out the more extensive periodic cleaning necessary. Self-cleaning types of viscous filter may also be used to avoid interrupting the service to remove the filter sections for cleaning purposes. Filters containing such substances as activated carbon may also be used for the removal of gases.

Air washers although primarily intended for the adjustment of temperature and humidity, at the same time effect a certain amount of cleaning.

Another apparatus for air filtration is that used for electrical precipitation. This method of dry-cleaning, which is now being developed for air conditioning purposes, depends for its action upon the provision of an electrostatic field set up by a fine wire charged to a high potential and positioned between two grounded rods. Particles of dirt passing through the field receive an electrostatic charge and are drawn to and deposited on the charge plates in the collector chamber. Diagrams of this method are shown in Fig. 23. Air containing impurities in the form of fine mineral particles, when subjected to this treatment, retains about one-tenth of a grain of dust per cubic foot, particles down to about 0.2 microns in diameter being separated. (The average diameter of a human hair is 100 microns.)

Ozonizing apparatus, which is used to produce an increase of the oxygen content of the air by a process of electrical spark discharge consists in general of the electrodes, transformer, switchgear, and a converter if operated from a D.C. supply of electricity. The ozone introduced into the air stream of a ventilating system in this way (which is similar in odour to that present in oceanic breezes) is intended to impart freshness into the atmosphere and so produce an invigorating effect upon the human body. There appears to be no evidence to show that a beneficial physical effect is produced by this form of air treatment applied in conjunction with the normal ventilation of buildings, although the psychological aspect cannot be ignored. It is also claimed that a more hygienic atmosphere is ensured for such work as surgery and food processing owing to the ozone's effect on bacteria.

Air heaters for installation in the main intake ducting are constructed of cast iron, steel and copper of circular and other sectioned

conduit, with supplementary surfaces in various formations for increasing heat transmission. They are arranged for use with hot water or steam, or heated direct with electricity, gas, and solid fuel, and the supply of heat should be thermostatically controlled so that it may be accurately regulated, in order that fluctuations in the temperature of the outside air will not vary the temperature of the air distributed within the building.

In general, a fresh air supply system of ventilation may be applied to buildings of every description, although it cannot be used indiscriminately on every occasion. The treatment, for instance, of part of a building only by a mechanical system may prove detrimental to the remainder of the building owing to the effect produced by the intermixing of air throughout the entire building. This contingency may therefore entail the provision of air locks in corridors and stairways.

4. Combined Systems. The introduction of air under pressure to a building, as occurs with mechanical systems, must mean its ultimate displacement from the spaces ventilated to others offering the least resistance to its flow. On this account, unless precautions are taken to direct the flow of air to be dispelled, it will disperse at random to regain pressure equilibrium. In consequence, the circulation of air cannot be entirely confined within the spaces ventilated. The same applies in the converse case, namely in the forced extraction of air from a space to be ventilated. It is circumstances such as these that have been mainly responsible for the introduction of a mechanical system combining fresh air supply with its extraction, as better control in the distribution of air can thereby be effected.

The supply and removal of air by the combined method, which is accomplished by the use of intake and extract fans working in conjunction with each other simultaneously, introduces air in quantities slightly more or less than that extracted, and so maintains a small atmospheric pressure difference, otherwise the system is virtually a balanced one. It reduces the infiltration of air from outside the building or counteracts the circulation of air from one section of a building to another according to the circumstances involved.

To secure the combined supply and extraction of air by natural means, the radiator fresh air inlet method, working in conjunction with an uptake shaft, roof extractor or the chimney of an open fireplace, may be used, and in the latter way it is also made to eliminate the draughts that occur with a fireplace when air is allowed to enter

indiscriminately. As a further means of admitting air under control a convector heater may be used.

To obtain the combined supply and extraction of air mechanically, a similar arrangement of apparatus is used to that already described for independent fresh air supply and extract systems. The positioning of the air inlet and extract registers may be such as to provide a cross circulation of air from floor to ceiling, or at high level from

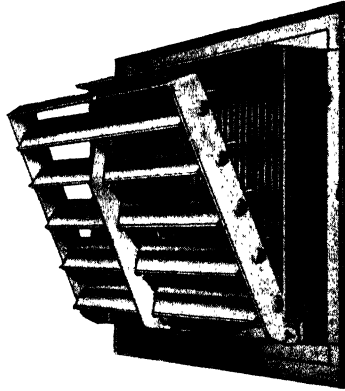

FIG. 24. ADJUSTABLE AIR REGISTER (REAR VIEW)

The register provides instant adjustment of air flow up, straight or down, and means of sideways adjustment.

(Air Conditioning & Engineering, Ltd.)

opposing sides of the room. Alternatively, the registers may be positioned side by side at right angles to each other and on the same level. The most effective position for them, however, can only be determined by a knowledge of all the circumstances involved.

The type of register used for the inlet of air is of importance, especially when both warmed and cooled air is to be introduced, as with complete conditioning systems. Where difficulties are likely to be encountered in the discharge of air due to draughts, a register providing adjustment of the air stream in both a horizontal and a vertical direction should be used. One type of register of this description is shown in Fig. 24.

The fans, which may be fixed either at the intake or discharge ends of the main ducting of each system, are of the centrifugal or air-screw type, with variable speed and remote control if required, and arranged for quiet operation when necessary. The main intake of the system is arranged in a position where the incoming air is not likely to be contaminated in any way, and the intake opening

suitably protected against the weather and ingress of foreign matter. The discharge outlet of the fan or main duct needs to be positioned to avoid creating a nuisance to surrounding property, that is to say, well clear of windows, doorways, and ventilators.

The use of combined systems of ventilation is to be recommended in the basement and sub-basement of buildings, and on other floors where sufficient ventilation cannot be obtained by natural means. It is usual for this method to be employed in the better class of office building and in restaurants, dance halls and large shops. It is also necessary in many places of entertainment when provision is not made for complete conditioning of the air.

Such systems should be used in every class of building where it is desired to ensure a more complete circulation of the air introduced. The stagnant pockets that are likely to occur when fresh air supply and extraction systems are used independently of each other are thereby avoided.

CHAPTER VII

COOLING, HUMIDIFYING, DE-HUMIDIFYING, AND COMPLETE CONDITIONING APPARATUS

1. Alternative Methods. The type and extent of the apparatus required to provide a particular atmospheric condition is influenced by the specific air treatment entailed and depends upon the method to be used. When air is warmed, for example, it should be humidified, and when cooled, de-humidified, if the relative humidity is to remain unchanged. At the same time other changes in the state of the air may be required.

It has been seen that warming of the atmosphere in a building can be undertaken without regard to its humidity, cleanliness or actual interchange, and, similarly, cooling of the air may be accomplished regardless of these three factors. When it is necessary for the air to be treated to provide a specific relationship between each of these changes, equipment for complete conditioning of the air is entailed. This should not be confused with the class of apparatus that merely produces some of these alterations in the characteristics of the air.

The apparatus necessary for cooling, humidifying, or de-humidifying may be of a distinct class for each of these purposes, according to the method used. The class of apparatus to be selected will depend upon whether only one of these changes is required independently of the others, or whether several are to be provided in conjunction with each other or in addition to certain other changes, and must form part of the process of entire conditioning.

The apparatus available for providing separate and combined changes of the above character is used for the following purposes—

- (a) Independent cooling.
- (b) Independent humidification and de-humidification.
- (c) Complete conditioning.

In the majority of circumstances, where cooling, humidifying or de-humidifying is necessary, the need for warming, cleansing or changing the air is also indicated, and one or more of these requirements may be provided by the above apparatus. It is usually only when some means of cooling is necessary to supplement natural ventilation, or the functions of ventilating apparatus, or to alternate

with the working of warming systems, that independent cooling apparatus is installed, unless it is required for manufacturing processes or storage purposes. Similarly, humidifying and dehumidifying apparatus is installed as an independent system, to function separately from or in addition to the warming and ventilating apparatus.

Partial changes in the state of the atmosphere that primarily affect temperature and humidity alone may therefore be produced independently of each other with apparatus designed for this specific purpose, and arranged to function as a separate system. The use of such apparatus may prove advantageous when it is not essential to provide total conditioning of the atmosphere.

Restriction in the amount to be expended for the purchase of apparatus, although often a vital factor in determining its selection, is usually detrimental to the service provided and it is as well to reflect upon the limitations of the apparatus used. Although the particular atmospheric conditions required may be obtained, such factors as appearance, reliability and maintenance must also receive attention.

Apparatus that is capable of producing simultaneously a complete range of changes in the state of the atmosphere, is usually to be preferred to one that provides humidification or cooling only, although these latter conditions may be of primary importance. Instances where independent cooling apparatus may be required are to be found in buildings where, owing to changes in their use, atmospheric conditions have deteriorated. The use of independent humidifying apparatus is confined almost exclusively to industrial buildings.

The cooling of air to be adequate at all times must rely upon the use of a supply of cold water or a refrigerant. This may be circulated through coils which provide the necessary cooling surface over which the air passes. Alternatively, the cooling coils may be used to lower the temperature of a water spray through which the air passes. The latter method may also be used without the cooling coils to secure evaporative cooling.

Evaporative cooling is only fully effective when the outdoor wet bulb depression is relatively high. Under these conditions cooling may be effected because the heat and moisture content of the air after saturation by the water spray can be below that of the air in the space to be conditioned and so be able to absorb sufficient heat and moisture. Owing to the infrequency of such external

atmospheric conditions prevailing in this country, evaporative cooling will often result in the effective temperature in the conditioned space exceeding the optimum for comfort.

Humidification of the air is brought about by the addition of moisture which may be introduced direct by the atomization of water in the conditioned space, or by passing the air through a water spray located in a centralized apparatus. De-humidification, which may also form part of the process of full air conditioning, is normally effected by cooling the air as previously described so that it loses moisture by condensation. The air is then reheated to the desired temperature. As an alternative method, de-humidifying of air by hygroscopic absorption may be used.

Only a complete conditioning apparatus will warm, cleanse and change the air and maintain a circulation essential to a completely satisfactory environment, in addition to humidifying, de-humidifying, and cooling.

2. Independent Cooling, Humidifying, and De-humidifying Apparatus. Cooling independent of entire conditioning may be carried out by the use of an air cooler situated in the space to be treated. In the same way humidification may be effected by utilizing local water atomizers to supply moisture to the atmosphere.

It is well known that reductions in temperature of the atmosphere or a substance when occurring under natural climatic conditions, are accompanied at times by condensation. Were it not for this, it would be possible during hot weather to utilize the radiators and panels of heating systems for unlimited convective or radiant cooling purposes by circulating through them a suitable cooling medium. As it is, however, the formation and accumulation of moisture on the surface of the radiators or panels and circulating pipes that would result from this practice makes it unsuitable for adequate cooling, and appliances have been produced to overcome the objection to the use of low temperature surfaces in this way for the necessary amount of cooling.

When therefore, cooling is the primary need inside a building, it may be provided by passing the air through a cooler positioned in the space requiring treatment. This appliance, which is designed to circulate a cooling medium either from a remote source of supply or from itself, is constructed to dispose of condensation from the air, and may be used to provide ventilation. One type of this appliance is seen in Fig. 25.

Cooling of the air by such an appliance permits of no control of

the relative humidity of the air cooled, which will be increased or diminished according to any changes in moisture content. Despite this deficiency, however, any variation that may occur in relative humidity should be adequately offset by the benefits derived from the lower temperature provided when used to improve conditions of comfort. The chief application of this type of appliance is to

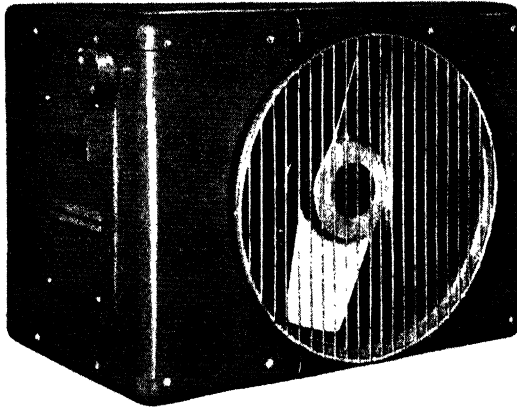

FIG. 25. SUSPENDED TYPE UNIT COOLER
(*Frigidaire, Ltd.*)

commercial purposes, such as warehousing, in breweries, and wholesale fruiterers.

The cooling appliance, which, in general, is of similar construction to a unit heater, is located and fixed in much the same way. Its normal function is to recirculate the air to be cooled, but when fixed adjacent to external walls it may be arranged to introduce air from outside the building for both cooling and ventilating purposes. Underneath the appliance a drip tray is provided for the collection of condensed moisture, which is carried away through a drain pipe to a convenient point for discharge. In addition, flow and return pipe connections are necessary from the appliance to the position from which the cooling medium is circulated (if this is not produced within the appliance). Electrical connections are made in the usual way to the motor driving the fan, automatic control of which may be provided if desired.

A cooling appliance of the class described circulating a secondary cooling medium or employing a refrigerant as in the direct expansion

type may, however, be used for the purpose of controlled de-humidification and temperature when installed in conjunction with a heater, a controlling humidistat, and thermostats.

Humidification of air, as the main objective, may be carried out by introducing water vapour directly into the atmosphere in a building by the use of a spray jet appliance fixed in the space to be

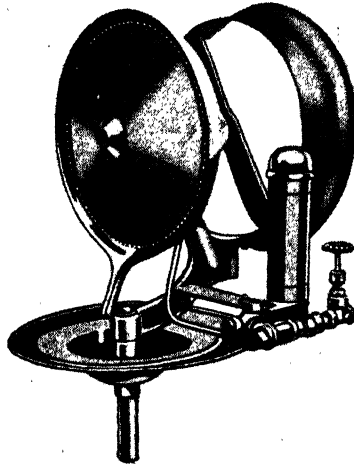

FIG. 26. UNIT HUMIDIFIER

Humidity control is embodied as part of the unit, which operates from the water and electrical supply mains.

(*Bahson, Mellor Bromley*)

treated. This means of adding moisture to the air—by the atomization of water in appropriate quantities—is one that preceded the complete conditioning system, and has been found to function satisfactorily when installed in buildings used for industrial purposes. Spray jet type humidifiers, which may be of either the open or enclosed pattern, usually necessitate compressed air or electricity, and water pipes to be taken to the small spray heads of the appliances. With this method care should be taken to ensure uniform humidity conditions by the provision of an ample number of jets working at moderate outputs. One type of unit humidifier is shown in Fig. 26.

Ventilating type humidifiers, which use a fan for the movement of air, may embody a system of ducting for air distribution and with this type of appliance a heater and cleaner may be incorporated and steam used instead of water for humidifying.

De-humidification in addition to being effected by a cooling

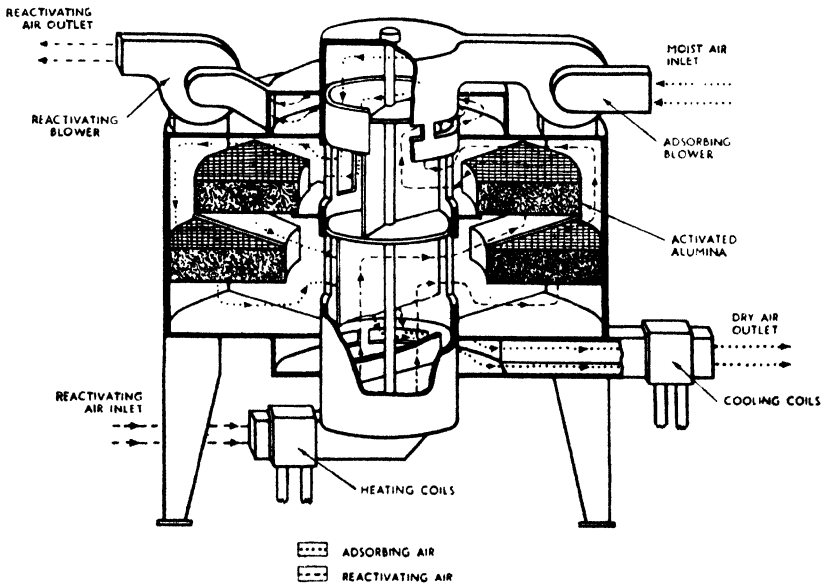
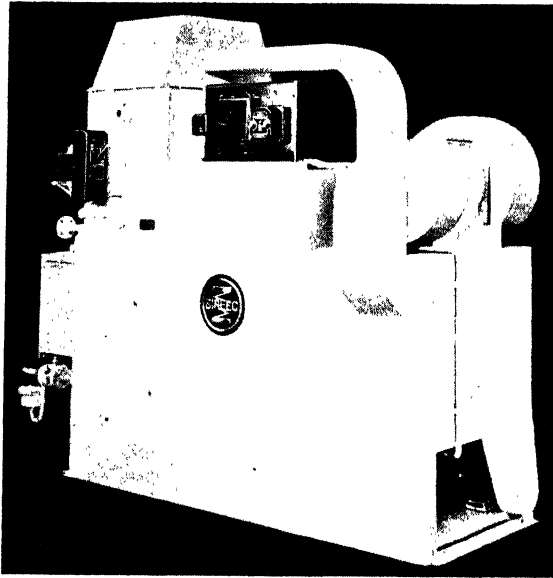

FIG. 27. ADSORPTION TYPE DE-HUMIDIFIER

The diagram shows the general arrangement of airways and drying agent. The multiple adsorber unit shown in the upper illustration uses steam for reactivation, and provides for automatic humidity and temperature control.

(Birlec Lectrodryer)

appliance as previously mentioned, may be undertaken by the hygroscopic absorption method to deal with a high latent heat load and for low dew points when relatively small air volumes are entailed. Solid calcium chloride is one substance used as an adsorbing agent owing to its low cost. Regenerated adsorbents such as silica gel or activated alumina offer a more convenient means as these substances can be re-used after adsorption. Fig. 27 shows one type of appliance using this method.

The air to be de-humidified is passed through one or more beds of the adsorbent material, which removes the required amount of moisture. The adsorbent is then reactivated in situ by application of heat, which may be obtained from electricity, steam, gas or waste sources, and is finally cooled ready for re-use.

3. Complete Conditioning Apparatus. The information already given regarding the treatment of air in buildings has shown that certain inherent functional defects occur in the transmission of heat with the use of heater and radiator appliances and certain warm air systems. These faults, which relate not only to the humidity of the air and its cleanliness but also to temperature stratification and the concentrated emission of heat from certain types of appliances, are largely overcome by the use of a properly designed and installed apparatus that completely conditions the air.

The improved conditions made possible by this type of apparatus, as far as warming is concerned, are due to the particular methods employed. Thus, in conditioning air at a central point, suitable for the ultimate state required throughout a building, heat is distributed more effectively by ensuring its continuous and complete circulation in the same way as is necessary when cooled air is provided by the system. In relying in this way upon the transmission of pre-conditioned air to create the atmospheric conditions required in a building, a more equable and less perceptible diffusion of warmth is assured. Such is not always the case when local heating appliances are used. It will be noted, however, that no radiant heating is provided with this system.

In addition to the improvements obtained in warming, the apparatus in providing cooling affords positive control of humidity in maintaining either higher or lower temperatures, and in the process helps to cleanse the air to be conditioned. The warming and cooling of a building by a system that also meets demands for changes in temperature with the minimum of delay is not only of advantage for normal winter and summer use, but also fulfils the requirements of

certain buildings that need both warming and cooling within a period of a few hours.

A further advantage of the equipment is that it recirculates the air. In re-using and reconditioning a large proportion of the air circulated throughout a building, appreciable fuel and power economy is effected, and a reduction made in the warming up or cooling down period entailed after the system has been put into operation.

The changes that can be made simultaneously in the temperature, humidity and cleanliness of the air are effected mainly by its passage through the washer which forms part of the humidifier embodied in the more common types of system. Air washers that were originally constructed solely for cleaning purposes were found to cool and moisten the air in obedience to scientific laws governing changes in the state of atmosphere. For example, when unsaturated air is passed through a washer mist and brought to saturation without change in the temperature of the washer spray water, it is cooled to the temperature of saturation. This is substantially the wet bulb temperature of the entering air, which may afford a means of cooling by advantage being taken of the natural conditions of the atmosphere.

Heating and cooling of the washer water, in varying the temperature of the saturated air produced, also enables it to be controlled, before being introduced into the space to be treated, at the theoretic dew point. Thus it is possible to regulate the quantity of moisture in the air delivered to a building by controlling the amount absorbed by the air according to the temperature of the washing water.

Cooling the air entering from outside to its wet bulb temperature does not alter its total heat content, and for general air conditioning it is necessary for some means to be provided for this purpose. Further cooling to lower the temperature of the washer water may be effected by using ice or a naturally cooled source of supply, but it is usually necessary for this to be done by refrigeration. The use of safe refrigerants of improved quality has facilitated the application of refrigeration for air conditioning, which increasingly depends upon this mechanical adjunct for its wider functioning and greater efficiency.

The apparatus required for complete air conditioning includes duct circuits, as with combined fresh air supply and extraction systems, and these may be arranged as shown in Fig. 28. A more comprehensive arrangement of equipment is necessary when zoning is entailed for the independent regulation of conditions in different sections of a building. The air supply and extract grilles may require

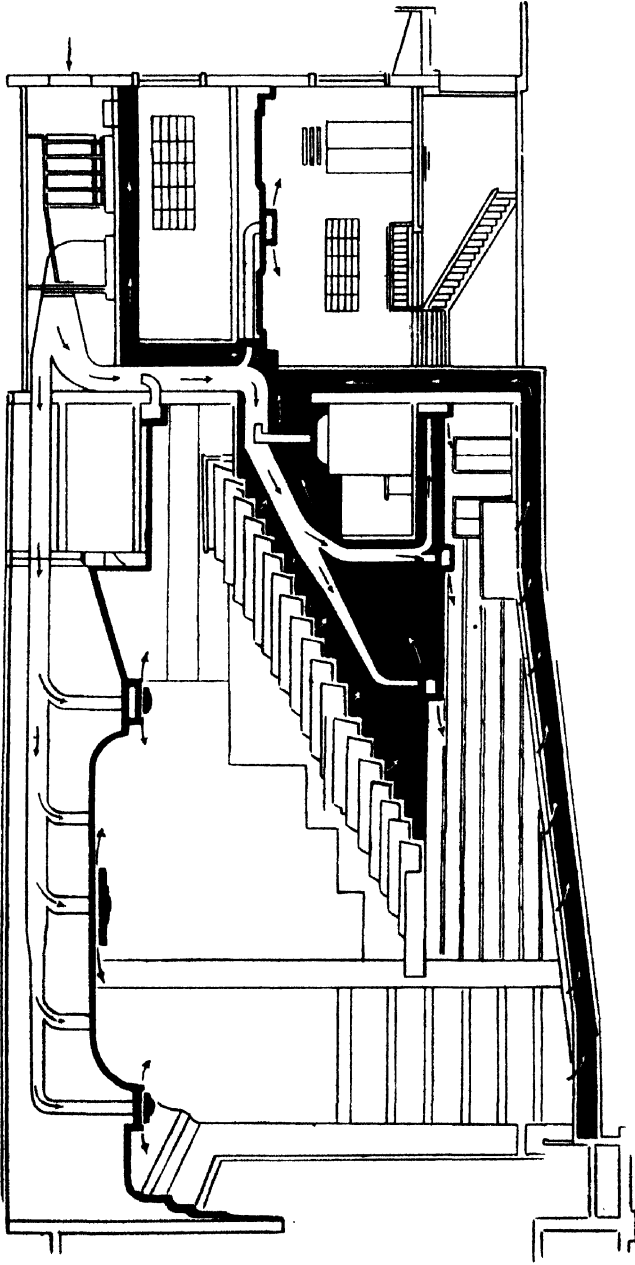

FIG. 28. AIR-CONDITIONING SYSTEM
Diagram showing the ventilating arrangements in a theatre.
(*Carrier*)

to be positioned at high, medium or low level, and some variation made in fan connections and the position of heaters. It is important that the grilles are carefully selected as regards type and the positions to be occupied in the spaces conditioned. In addition, a humidifier is necessary and also automatic control gear. The humidifier chamber when of the washer type is constructed of sheet metal, concrete or glass, and accommodates the spray nozzles, scrubber

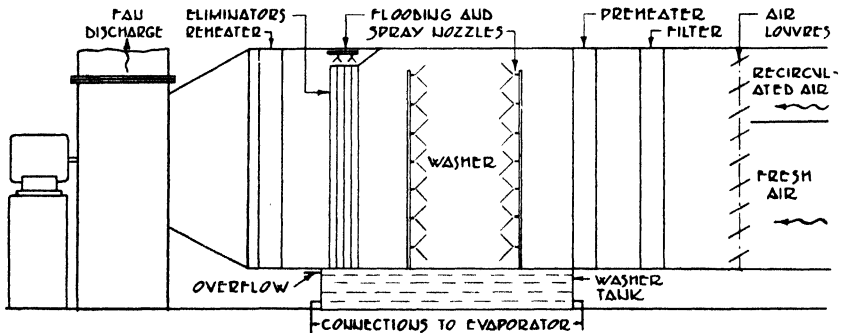

FIG. 29. DIAGRAM OF AIR-CONDITIONING CHAMBER

and eliminator plates, the circulating water, and also the air heating coils, and the evaporator or cooling coils positioned above or submerged in the cooling water tank, or exposed to the air stream as in other types. One arrangement is shown in the diagram in Fig. 29.

The refrigeration compressor, condenser, atmospheric water cooler, and spray water heating calorifier comprise other items of subsidiary apparatus.

The cleansing of the air is assisted by the washer as part of one process of conditioning, but in dealing with atmosphere contaminated by fog and heavily laden with other impurities, supplementary filters are required. If it is desired to ozonize the air before distribution, electrical apparatus for the production of ozone in suitable quantities is installed at a convenient point for connection to the main air ducting of the system.

Air conditioning systems, other than those utilizing centralized equipment with ranges of distributing ductwork and auxiliary apparatus, are usually referred to as conditioning units. This type of equipment, which is factory assembled complete with the components as required, may be installed as a room unit or concealed within a suitable compartment of the building structure adjacent or remote from the space to be conditioned.

These appliances may be either mounted on the floor or suspended

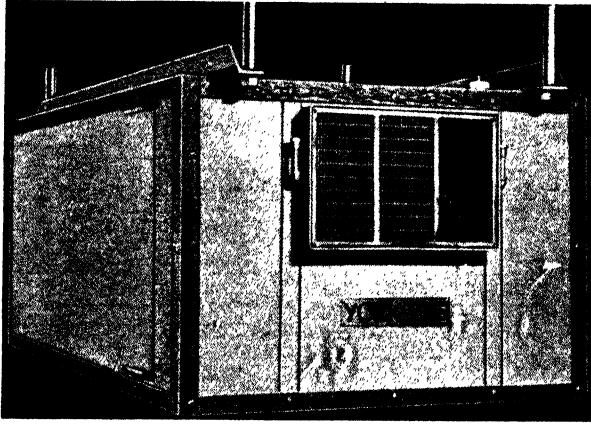

FIG. 30. AIR-CONDITIONING UNIT

Appliance of the horizontal type which may be fixed within the conditioned space or adjacent thereto and connected by ducts.

(York)

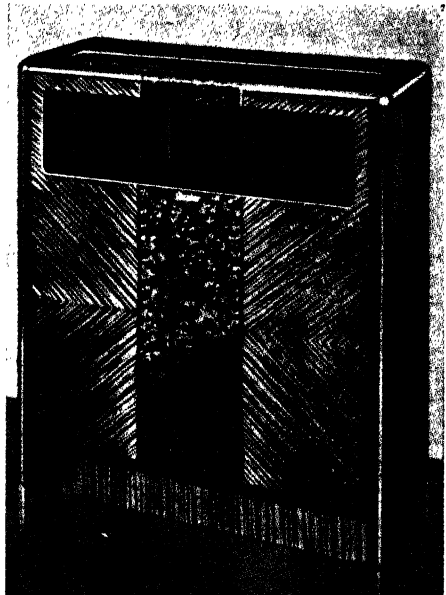
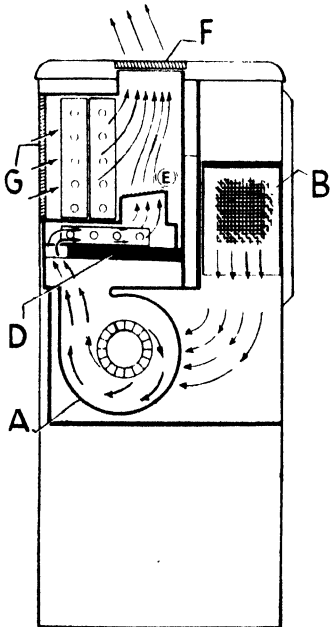

FIG. 31. AIR-CONDITIONING UNIT

Cross-section and external view of self-contained type of unit. The diagram indicates the high pressure fan (A), filter (B), sound silencer (D), ejector nozzles (E), outlet grille (F), and inlet grille (G).

(Carrier)

from the ceiling, and constructed as a self-contained (portable) unit or as an indirect unit. The self-contained type requires electric or gas connections and sometimes water and drain services, which may be disconnected to enable the unit to be moved to another position. Indirect types are dependent upon a supply of hot water or steam and also a cooling medium such as brine or a refrigerant circulated from a conveniently situated source of supply.

Air conditioning units may be further classified according to whether the fan is designed for free delivery, or against a pressure, as is necessary with air ducting when used with an appliance positioned outside the conditioned space. The units may also be air or water cooled, depending upon the amount of cooling required. Fig. 30 shows the appearance of one type of unit.

Units such as those described which have been developed for the purpose of dealing with comparatively small spaces in both new and existing buildings, are contained within cabinets of attractive appearance finished to harmonize with surrounding decorations, as in Fig. 31.

Complete conditioning installations are used extensively in industrial buildings, where they are able to provide the specific atmospheric conditions necessary for certain manufacturing processes. They are also installed in theatres, hotels, large provision stores and luxury blocks of buildings where needs justify a more comprehensive treatment of the atmosphere.

CHAPTER VIII

CENTRAL PLANT

1. Boiler House. The planning and construction of a boiler house will be dependent upon the type, extent and arrangement of the equipment to be used for the generation of heat, or its utilization from external sources of supply, for distribution throughout a building. These factors combine to produce a far-reaching effect upon the service to be provided by the apparatus as a complete installation, and upon the decisions made in regard to the accommodation of the central plant will largely depend the ultimate overall efficiency obtained from the installation. Some approximate information regarding space requirements for central heating boiler plant is given in Table VI, which also includes particulars of flue sizes. The significance of the class of fuel used is dealt with in

TABLE VI
BOILER HOUSE AND CHIMNEY SIZES (APPROX.)

*Additional space is required if hot water supply apparatus is to be installed
Fuel store sizes allow for approximately two weeks' supply*

VOLUME OF SPACE TO BE HEATED	HEATING CHAMBER		FUEL STORE		INTERNAL CROSS-SECTIONAL AREA OF SMOKE STACK IN SQ. INCHES						
	Area in sq. ft.	Height in feet	Area in sq. ft.	Height in feet	Height of smoke stack in feet						
					25	50	75	100	125	150	
25- 50	90	8	15	8	80	—	—	—	—	—	—
50- 100	150	9	20	9	110	—	—	—	—	—	—
100- 250	200	10	40	10	170	120	100	—	—	—	—
250- 500	250	11	90	11	320	230	190	160	140	130	—
500- 750	320	12	170	12	520	370	300	260	230	210	—
750-1000	430	13	250	13	770	550	450	390	360	320	—
1000-1500	520	14	330	14	—	730	600	520	470	430	—
1500-2000	540	15	450	15	—	1080	880	790	710	650	—
2000-2500	575	16	520	16	—	—	1200	1040	920	840	—

Note. Areas above heavy lines should be provided whenever possible.

Chapter X, a full appreciation of which is necessary before attempting to consider details of the boiler house and equipment to be used.

The location of a boiler house in relation to the building itself and to the remainder of the apparatus is of importance, since this will affect the initial and operating cost of the installation and

convenience of the occupants. Boiler plant that is to serve such buildings as hospitals, blocks of flats or large hotels is better housed separately when practicable to lessen the disturbance to residents caused by its operation. In the planning of buildings there is often little choice of position, however. The heating chamber must needs be situated in that part of the site most suitable for excavation, fuel delivery or flue erection, and for these and other reasons an ideal location is not always possible. The shape and levels of the site may, therefore, present difficulties that are not easily overcome, but whenever possible a centralized and separate position should be selected for the reasons given. Circumstances may even preclude locating the boiler plant on the ground or lower floors, for example, in existing buildings where the floor area is particularly valuable or unsuitable for conversion to such a purpose. The top floor or the roof may be the only alternative position afforded for the boiler house under these conditions.

The level of the boiler house is of little importance other than in its effect upon the general planning of a building and the class of fuel to be consumed, except for the smaller installation which, when dependent upon a gravity circulation, generally has the boiler plant housed in a basement or cellar to facilitate the installation and working of apparatus, and reduce its cost. There is, however, no objection to the boilers of such installations being placed at ground level when the lower position is unavailable or can only be provided at a cost that does not justify the advantages mentioned.

No restriction should be offered to the size of the boiler house if the plant is to be operated and maintained efficiently. Limitations are sometimes caused by confining the boiler house in vicinities most convenient for fuel delivery, but mechanical fuel conveyors might well be used to overcome obstructions to the manual conveyance of solid fuel from or to bunkers remote from the boiler plant or the passage of delivery vehicles. Conveyors should also be regarded as a means of facilitating the general use of this class of fuel when problems crop up in the location or design of heating chambers and fuel stores.

In the construction of a heating chamber, a provision sometimes overlooked is that required for the admission of air to the chamber not only for ventilation but for combustion purposes. This may amount to a considerable volume and will therefore entail suitable openings. Moreover the quantity of air extracted by the stack cannot be relied upon to provide, at the same time, sufficient ventilation for the prevention of abnormal temperatures and the removal

of fumes, and other means should be adopted for this purpose. For instance, the air space within the walls of the flue when a cavity form of construction is used may be utilized. This also serves as a further means of thermal insulation, but at the same time may reduce boiler draught owing to air infiltration.

Since the planning of the heating chamber, depends upon the type of plant to be installed and the size of the installation, it is necessary for such particulars to be known before provision for accommodation can be made in any detail. In addition to the space necessary for the boiler plant itself, separate chambers may be required for the accommodation of calorifiers, humidifiers, fans, pumps and fuel. The storage of fuel will often require special facilities (as shown in Fig. 32), including suitable accommodation above the level of plant to facilitate charging the boilers or hoppers, an arrangement that is necessary with certain types of solid fuel-burning appliances such as that shown in Fig. 33.

Difficulty in arranging suitable access for the delivery of solid fuel and its storage may suggest the alternative use of gas or oil, the storage of which may be facilitated by the use of tanks positioned some distance away from the boiler plant and placed underground if necessary.

In considering the construction of the chimney stack it should be remembered that this is not usually intended solely for the purpose of disposing of combustion gases at a level suitable to ensure that a nuisance will not be committed. The stack should be dimensioned and constructed in a manner that will enable it to function under conditions favourable to the natural flow of gases for the extraction of the required quantity. Accordingly, stacks other than those using mechanical draught must be built to a certain minimum height to provide the requisite draught and be of an internal cross-sectional area sufficient to remove the volume of gases produced.

In the event of site conditions not allowing the required size of stack because of long runs of horizontal flues, the marring of architectural features, or the extension of plant, it becomes necessary to remove the gases by mechanical means. This is an alternative that will entail the use of a specially constructed fan to provide forced or induced draught.

Other items of builders' work required in a boiler house will include bases for the boilers and pumps, and suitable supports for hot water storage cylinders or calorifiers. Sumps, chases and trenches may also be necessary in addition to air ducts for ventilating systems.

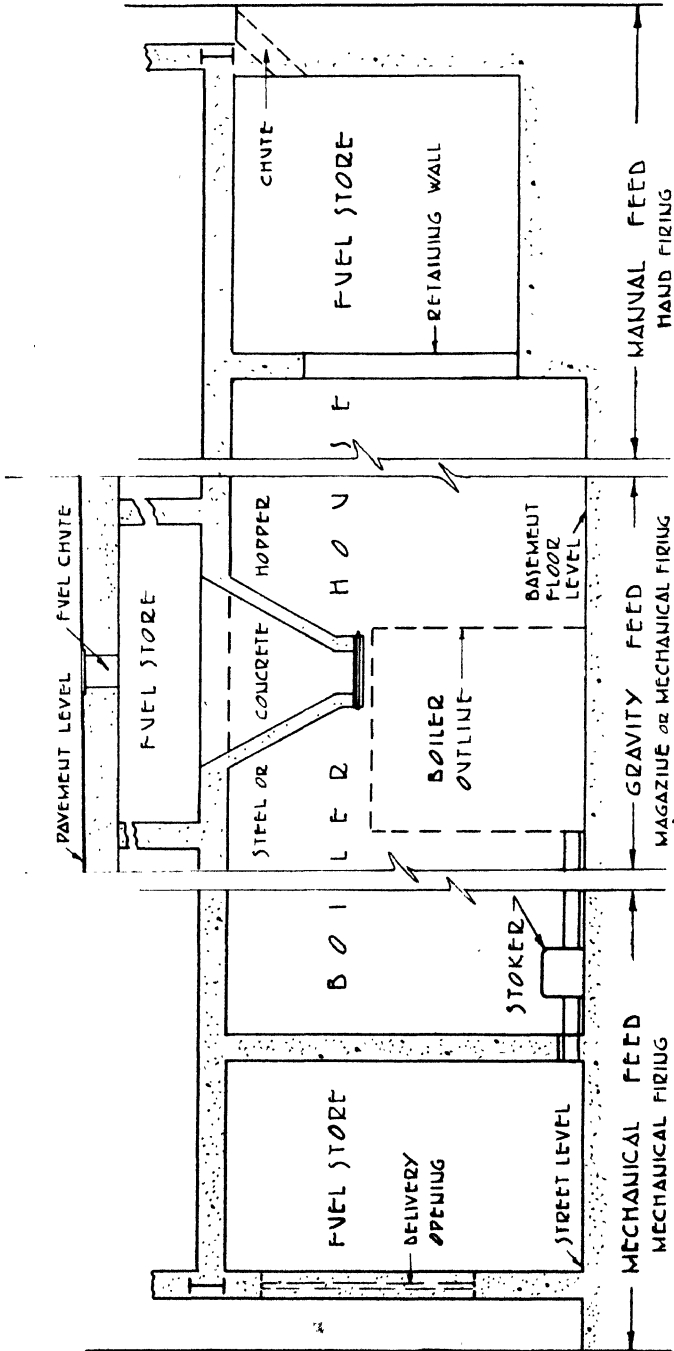

FIG. 32. SOLID FUEL STORES

Variations in arrangement of fuel storage accommodation according to the method used for firing boiler.



FIG. 33. A MAGAZINE TYPE BOILER INSTALLATION

(Gravico)

2. General Arrangement of Plant. The arrangement of plant in general varies according to the class of fuel used and the manner in which it is consumed, the medium used for heat conveyance, the extent to which it is to be automatic, and other features of less importance. All of these will affect the lay-out of the plant in some way or another.

Hot water for central warming, domestic and other purposes, is made available either direct from the boilers and storage cylinders, or indirectly through calorifiers supplied with either hot water or steam as the primary heating medium. This will further affect the arrangement of plant. The calorifier, or exchange method, which transfers the heat from the water or steam, for secondary use in the distributing circuits, should be used when the hot water supply system is combined with the warming system. This enables one boiler plant to serve both installations without intermixing the water of the two systems which, if allowed, would cause defective service.

The indirect method is also used when steam is required, or already available for other purposes, to avoid circulating this medium through the space heating appliances. The ultimate service provided by either steam or hot water as a primary heating medium can be similar, the preference for one or the other being influenced chiefly by the character of the services to be provided by the boiler plant. The indirect method may also be applied to independent hot water supply systems, to preserve the initial thermal efficiency of boilers, and avoid any periodic descaling that may otherwise become necessary.

Mechanical conveyance of fuel from bunkers or storage tanks to the furnaces of boilers, together with its automatic combustion, will require provision to be made in the general design of the plant for the accommodation of the necessary equipment.

Restrictions in the floor area available for plant, when compensated by additional height in the heating chamber, will cause a variation in the type of equipment used. These conditions, necessitating the installation of equipment on a vertical plane rather than a horizontal one, will entail the use of vertical types of boilers, calorifiers or cylinders, and circulating pumps, and possibly the disposing of other equipment overhead or on mezzanine floors.

Thermal storage plant, used as a means of accumulating heat for such times as the main supply is not available, or to improve the load factor and for other reasons, is arranged according to the source of heat supply. Combustion boilers or steam turbines may be employed to supply heat to the storage vessels by using medium or high temperature water or steam, or this may be supplied by generation in electrical boilers. Alternatively, electrical immersion heaters, located in the vessels themselves, afford a means of heat supply. The actual electrical method used will depend upon the load and the supply voltage available.

In medium and large size installations some means of avoiding interruptions to service due to failure of plant and maintenance should be arranged. In the absence of a reserve boiler this contingency can be met in two ways. Either a margin of power output can be provided in each boiler so that the aggregate of excess power thus provided is equivalent to the capacity of a single boiler, or use be made of the reserve power that is available for long periods when both heating and hot water supply plant is used. With the latter system the combining of all boilers by interconnection, for temporary emergency use, enables any one boiler to serve either installation.

To maintain continuity of service of a complete or partial nature, duplication of calorifiers, storage cylinders, fans and pumps is usual, although in the case of fans this is often restricted to electric motors only. As an emergency drive for fans and certain types of pump, steam turbines may be provided as an alternative source of power in the event of failure of the electrical supply.

The installation of ventilating and complete air conditioning apparatus, which may constitute a large proportion of the plant used, must necessarily vary in its general arrangement to accord with the lay-out of the remainder of the plant. The disposition of humidifiers, fans and main ducting will, therefore, require to be taken into account according to both the scheme to be adopted and the planning of the plant in general.

In many instances it is desirable to locate air conditioning plant close to the boilers to facilitate the supply of heat and the operation of the plant as a whole. Conditions may, however, necessitate some of the equipment being installed in other parts of the building, or it may be found more convenient to locate the greater part of it on the roof, as in the case with some types of boiler plant.

The use of water softening equipment, although affecting the arrangement of plant in minor details only will, nevertheless, require space to be allocated for its operation. This equipment, which may be necessary to maintain the full efficiency of hot water and steam boiler plant, is also of advantage when used in conjunction with the supply of water for laundering or general domestic purposes.

3. Boilers. The different types of boilers available have been developed mainly with the object of each being utilized to the best advantage in conjunction with particular systems or in certain classes of building only, although some present greater opportunities for general use than others. Each type of boiler possesses features

which are of particular advantage in specific circumstances, but, like all other equipment, the advantages gained in some respects with certain types are often obtained at some disadvantage in other respects.

The various types of boiler may be divided into five main classes, according to the design embodied in their construction. They are designated in general as follows—

Back. Domestic and heating types.

Firepot. Domestic type, hand or magazine fuel feed, natural draught.

Sectional. Domestic and heating types, hand and magazine fuel feed, natural and forced draught and mechanically fired.

Cylindrical, shell. Hand or mechanically fired, natural, forced and induced draught.

Tubular shell. As above.

The back boiler is fitted in the back of an open fire, stove or range.

The firepot type of boiler, generally known as the domestic boiler, succeeded the "back" boiler of the old type of kitchen range for the supply of hot water in the household, and has now become one of the chief means of serving this need in residences, although it is extensively used in other classes of building when its capacity is sufficient to fulfil requirements. Its adaptability for cooking purposes, together with its low cost, is largely responsible for its popularity. The simple form of construction, comprising a fire-box surrounded by a cast iron or steel water jacket, makes it cheap to manufacture and easy to work, but also makes it a boiler of low thermal efficiency.

Boilers of this description are intended only for the direct supply of hot water, as distinct from a supply that is heated indirectly by a calorifier. They are accordingly constructed so that the deposits of scale which accumulate inside the waterways owing to continuous changes of fresh water can be removed through the clean-out openings provided. The necessity for descaling is largely responsible for the simple design of this particular type of boiler.

The cast iron or steel sectional type of boiler is one that is in most common use to-day for central heating purposes owing to its ability to meet the general demands of the average class of building. Its simplicity of use, compactness, ease of maintenance, and adaptability for extension and repair are features that combine to make it a boiler suitable for general purposes either independently or

in battery formation. The boiler is constructed on comparatively simple lines, and consists usually of a number of vertical sections which, when assembled together, comprise the fire-box, with forward and backward flue passages above and ash-box below. An illustration typical of this class of boiler is shown in Fig. 34. When required, clean-out openings are provided in each section for the removal of scale, to enable the boiler to supply hot water direct to the draw off points through a storage cylinder.

Sectional boilers, which are suitable for use with both water and steam, depend for their reliability, durability and efficiency upon the class of material used in their construction. Cast iron imposes certain limitations in regard to the working pressure of a boiler, methods of design and manufacture, and its period of life, but at the same time reduces cost as compared with mild steel. This latter material is, therefore, to be preferred if a higher standard of performance and permanence is desired, and it usually justifies the extra cost incurred.

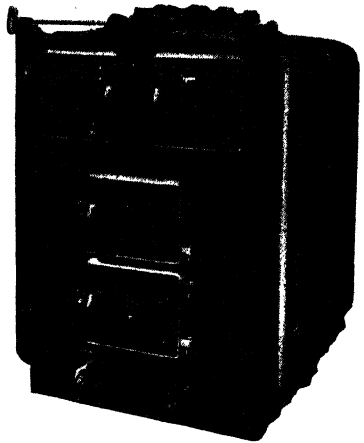

FIG. 34. CAST-IRON SECTIONAL BOILER
Shown without insulating jacket.
(Crane)

A modified form of the sectional type of boiler is that known as the magazine or gravity feed pattern, which is designed to store several hours' supply of solid fuel, this being fed automatically to the fire grates as it is consumed, and when provided with thermostatic control, burning for several days without attention at low output rates. The fuel, which is either fed into the boiler hopper by hand or arranged to gravitate into it from overhead bunkers or conveyors as shown in Fig. 33, may be of the manufactured smokeless class such as cokes, or anthracite and Welsh dry steam coal, using natural or forced draught. On account of its equable rate of combustion, this labour-saving type of boiler is more efficient than the orthodox sectional type, which is known to be a boiler of medium efficiency only. Figs. 35 and 36 show different types of magazine boiler.

Cylindrical shell boilers, of which the "Lancashire" and "Cornish" types are representative, are installed principally in factories, institutions and hospitals, where steam is usually required. Boilers

of this description, however, may be used in many other classes of buildings where there is ample floor area to accommodate the extended heating surface and the brickwork setting required.

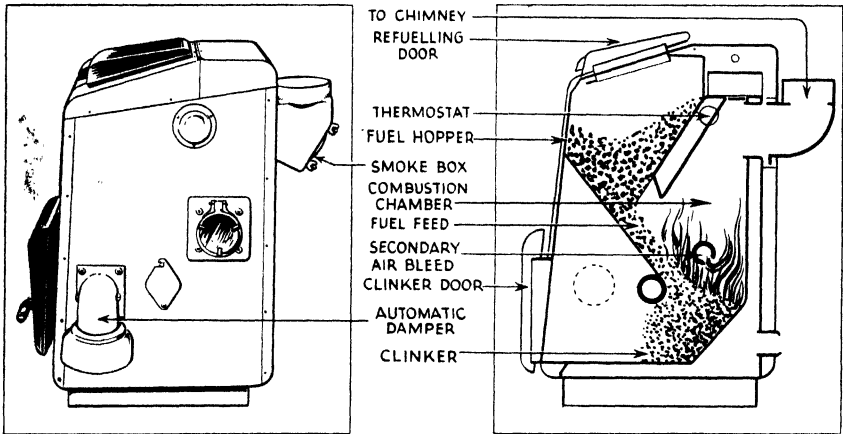
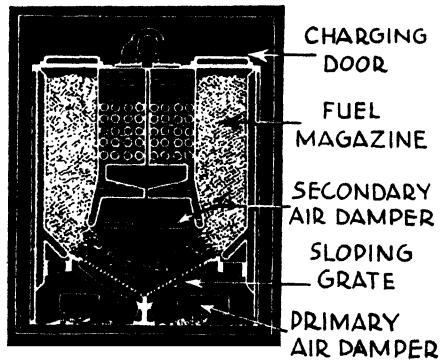

FIG. 35. MAGAZINE BOILER

Constant boiler water temperature is provided by the thermostat embodied.

(Janitor)



CROSS SECTION

FIG. 36. STEEL MAGAZINE BOILER

(Gravico)

This type of boiler is constructed with an outer steel shell containing single or double fire tubes, the water and steam occupying the intervening space, which, owing to its generous proportions, also acts as a heat reservoir to cope with the sudden demands in output occasioned by steam processes used in manufacture. A boiler of this type is comparatively easy to operate, and owing to

its reliability requires the minimum of attention for maintenance. It is, however, a medium efficiency boiler only unless used in conjunction with an economizer, when an appreciable improvement in this respect can be obtained.

Other types of cylindrical boilers are those of the vertical pattern which, in dispensing with a brickwork flue setting, make good the loss of heating surface by the use of supplementary fire or water

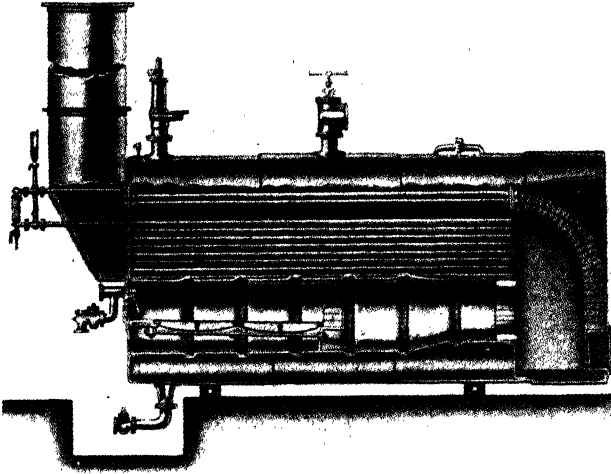

FIG. 37. SELF-CONTAINED DOUBLE-PASS TYPE BOILER (LONGITUDINAL SECTION)
(Pazman Economic)

tubes. Boilers of this description, which offer a wider range of design than those of horizontal pattern, can be used to advantage in boiler houses where the floor space is limited.

Tubular shell boilers—both horizontal and vertical—of the “economic” and “super-economic” type are utilized in a large variety of buildings where space limitation calls for a boiler of compact construction and maximum thermal efficiency. This type of brick-set or self-contained boiler, which is constructed with single and double fire tubes, is provided with numerous supplementary flue tubes for the forward and backward passage of gases, on which account adequate draught is required for combustion. These high efficiency boilers require skilled attention for their operation, and for the same reason must receive periodic maintenance of a more detailed nature. Fig. 37 illustrates a boiler of this description.

Variations in the design of tubular boiler most frequently used in buildings are to be found in the marine and locomotive class, and also the high temperature hot water boiler in which the flue combustion gases pass externally to the tubing containing the circulating water.

In addition to the different types of boiler described, others are available, designed for the purpose of consuming waste fuel and utilizing the waste heat of exhaust gases and vapours.

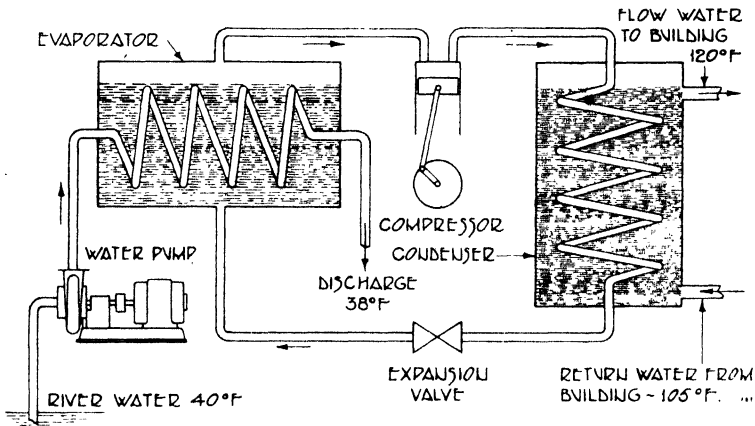

FIG. 38. DIAGRAM OF HEAT PUMP

The heat extracted from the low temperature water by the evaporation of a refrigerant in the closed compressor circuit is pumped up to a temperature suitable for use, through the condenser, for space heating and hot water supply.

Reference must be made in this section to the heat pump which, although not in the ordinary sense of the word a boiler, may be classified as heat producing equipment. Owing to recent progress made in the application of this refrigerating plant for space heating and hot water supply purposes, developments in its design and construction in the near future should further advance its use.

The purpose of the heat pump is to extract low-grade heat either from the atmosphere or low temperature water, and increase its temperature to that required for useful work. In this way the pump renders effective heat that otherwise cannot be utilized because its thermal value is insufficient for the purpose required. The advantage of the heat pump is its ability to produce heat in excess of the heat equivalent of the mechanical power required to operate the plant. The quantity of heat made available may be three or more times that in the energy necessary to drive the equipment, and according to this ratio depends the co-efficient of performance.

The heat pump comprises in general an evaporator which extracts

the heat from the supply of water or air, together with a compressor to increase the temperature of this heat, which is transferred in the condenser to the water to be circulated through the building for warming purposes. A diagrammatic lay-out of one arrangement of equipment is shown in Fig. 38.

A further advantage of this method of upgrading heat is that it includes the means of providing heating and cooling alternatively.

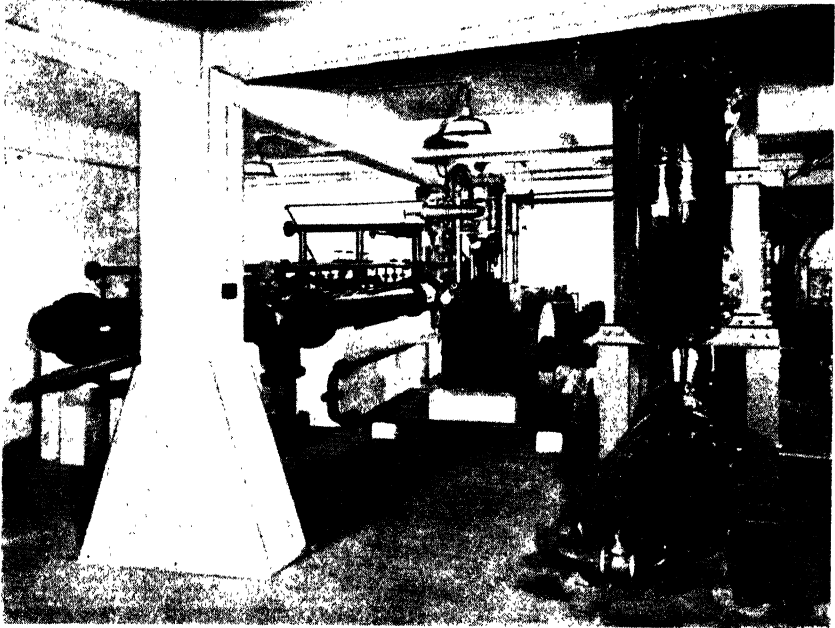

FIG. 39. NORWICH HEAT PUMP

An installation capable of heating a building of 500,000 cu. ft. capacity.
(Reproduced by permission of John A. Sumner, M.I.E.E., M.I.Mech.E., F.I.I.A., City
Electrical Engineer)

a combination that renders its use fully effective. As with other types of heat producing equipment, its installation can only be economically practicable when its operating cost is equal to or less than the cost of heating by other methods.

There are a number of heat pumps in use in America and Switzerland, but as far as is known, the "Norwich" heat pump is the first large installation ever carried out in this country for building heating. This was designed and constructed under the direction of the City Electrical Engineer and is illustrated in Fig. 39. Owing to the character of the materials and the plant available being

affected by war-time restrictions, the equipment installed was of an experimental nature which precludes the attainment of high efficiencies. According to performance records the installation has been delivering to the building 3.45 times as much heat as that actually expended electrically to drive the heat pump, and later modifications of the plant are expected to result in the return being increased.

4. Mechanical Firing Equipment. The reasons for procuring the combustion of fuel by mechanical methods in preference to hand firing are explained in Chapter X. It is necessary at this stage, however, to understand the different methods employed so that the considerations governing their application shall be known. Many of the boilers described are primarily intended for the consumption of hand fired solid fuel, but with the exception of the back boiler and magazine types, and certain sizes of the firepot type, each may be adapted for mechanical coal and oil firing, and, in some instances, the consumption of gas. This latter fuel, however, is usually consumed in a boiler designed especially for the purpose, as is also the case when electricity is used.

Gas, when used as a fuel, must necessarily be controlled by semi-mechanical means to obtain a normal combustion efficiency, and the general arrangement of equipment entailed requires little explanation or comment, to appreciate the principal features involved when it is fired at low pressures. There is some variation, however, between one system and another when the method of combustion depends upon the use of air or gas above atmospheric and normal supply pressures which necessitates additional apparatus such as fans, injectors and refractories. Methods such as these are used when it is important to obtain maximum efficiency.

As already mentioned, in gas fired boilers the burners should be embodied as part of the combustion chamber design. Special arrangements of burners, however, can be used to adapt a coal-burning boiler to gas, thus rendering possible the conversion of the boiler to an alternative fuel.

The rate of combustion of the gas, whichever system is used, is controlled thermostatically in accordance with boiler temperature requirements, and no manual adjustment is necessary. An illustration of a gas fired boiler plant is seen in Fig. 40.

To burn fuel oil satisfactorily it is necessary to break it up into a fine mist; this is usually termed "atomization" and is generally achieved by one of two methods—

(a) A relatively high velocity stream of air or steam impinging on a comparatively slow flow of oil; or

(b) pumping oil at high pressure through a specially designed nozzle.

Specially designed burners are used. Those employing the former method are generally known as air or steam jet burners, whilst those that use the second method are called pressure jet burners.

For small central heating boilers a self-contained type of oil

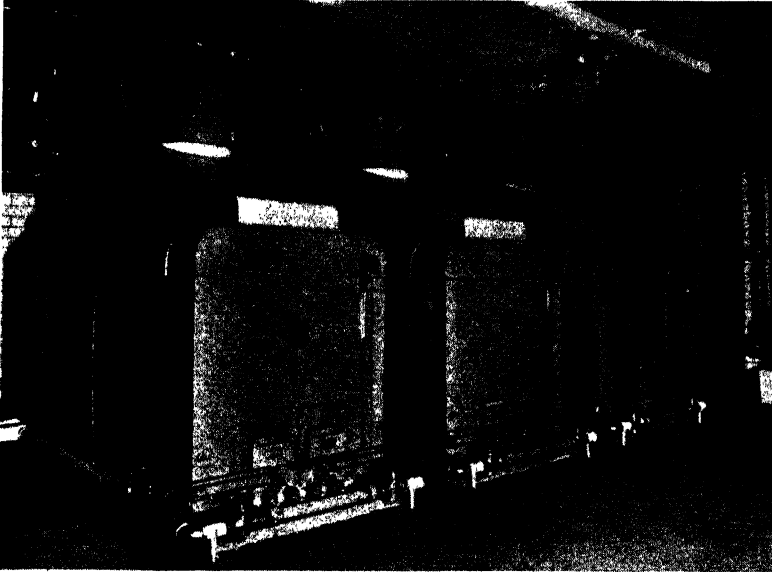

FIG. 40. GAS-FIRED BOILER PLANT
Three Potterton "Rex" No. 3 gas-fired boilers.
(De La Rue Gas Development, Ltd.)

burning unit is used, comprising the burner, oil pump, fan and motor, ignition device and oil-preheater. The unit is mounted on a compact bedplate, and its operation is completely automatic, being controlled by a thermostat. The labour needed to look after these burners is virtually negligible.

For larger boilers semi-automatic burners are employed, which operate on a high/low flame principle. An attendant is necessary to light up the burner and extinguish it.

With both completely automatic and semi-automatic burners safety devices are provided which shut off the oil supply in the event of flame failure.

For batteries of large boilers where there is usually a man constantly in attendance, hand-controlled burners are very often

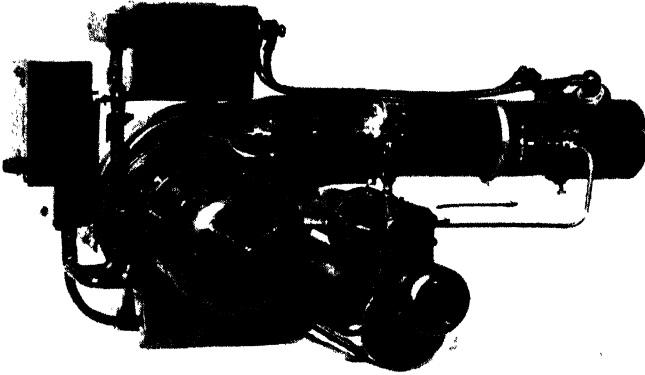

FIG. 41. FULLY AUTOMATIC HEAVY OIL BURNER
 An installation arrangement of this type of burner is shown in Fig. 103.
(Clyde Fuel Systems, Ltd., and Combustions, Ltd.)

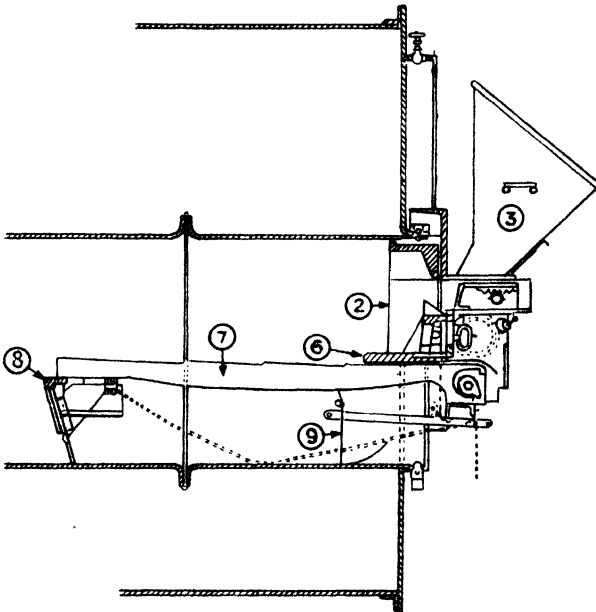

FIG. 42. NATURAL DRAUGHT COKING STOKER APPLIED TO LANCASHIRE BOILER (PART LONGITUDINAL SECTION)

- | | |
|---|-----------------------------------|
| (1) Stoker front. | (6) Coking plate. |
| (2) Baffle plates and front protection. | (7) Self-cleaning grates. |
| (3) Hopper. | (8) Back sealing device. |
| (4) Stoker feed mechanism. | (9) Patent air-regulating damper. |
| (5) Fire doors. | (10) Stoker driving gear. |

(Bennis)

employed, the regulation of the oil burner by hand being simple and easy.

Although oil is sometimes fed to the burner equipment by gravity from overhead tanks, it is modern practice to employ pumps to give a constant feed of oil to the burners at enve pressures. An illustration of a self-contained type of unit appears in Fig. 41.

Mechanical stoking equipment for use with solid fuel fired boilers

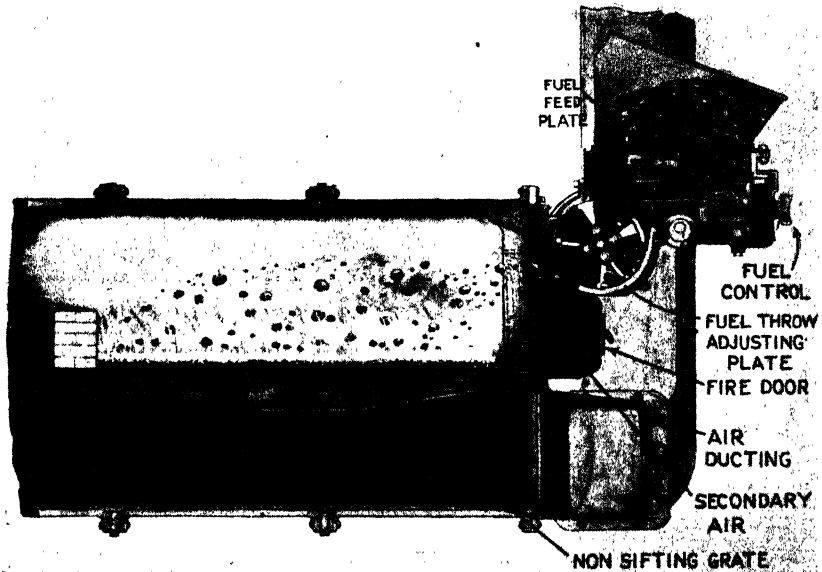

FIG. 43. SECTIONAL VIEW OF SPRINKLER STOKER
APPLIED TO LANCASHIRE BOILER

(Niagara Engineering Co., Ltd.)

of the class described operates on two distinct principles. The overfeed system, which is one employing either the sprinkler or coking method of fuel feed to the fire grate, is used for cylindrical and tubular boilers. The other, the underfeed system, is used with sectional type boilers in addition to those of the cylindrical and tubular class.

Stokers that function by the sprinkler method are provided with mechanism which intermittently sprinkles fuel on to the fire grate as distinct from the coking stoker which feeds fuel on to a coking plate within the boiler before passing on to the moving bar grate for final combustion. The simplest form of the latter type is the gravity feed burner or semi-producer stoker which usually burns coke and anthracite, gravity fed from a hopper to a water cooled

shelf or chamber where primary combustion takes place aided by air from a fan. An illustration of one type of coking stoker is shown in Fig. 42, and of the sprinkler stoker in Fig. 43.

The underfeed stoker delivers fuel, together with air under pressure, into a combustion retort at the boiler base, in place of the fire grate. The fuel may be screw or ram fed, the latter method being capable of dealing with a wider range of fuel. A screw type

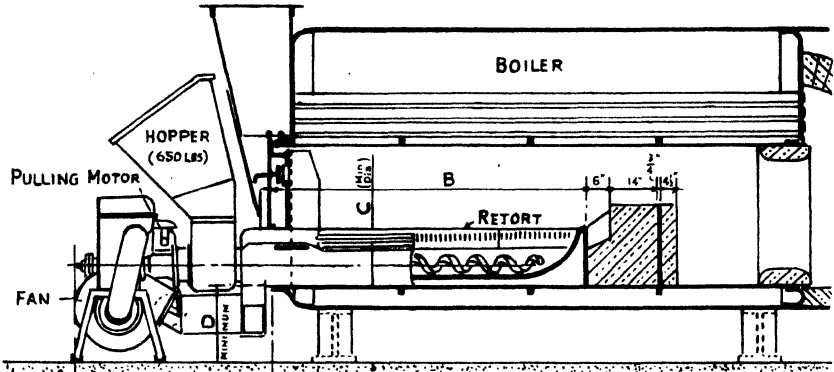

FIG. 44A. SCREW TYPE UNDERFEED STOKER (HOPPER TYPE)

Stoker fitted to single flue tubular boiler.

(Riley Stoker Co., Ltd.)

of underfeed stoker with hopper is shown in Fig. 44A. The bunker type, which feeds fuel direct from the fuel store to the boiler, is shown in Fig. 44B.

Each system of mechanical stoking enables fuel to be either fed by hand into hoppers adjacent to the boiler or mechanically conveyed direct from the bunker to the boiler, the rate of supply to the furnace, with either system, being adjusted by regulation of the speed of the fuel feed mechanism. The operation of the fuel feed may be controlled manually or automatically by thermostatic devices. Ash removal is carried out by hand with the underfeed systems except when anthracite is used, when its removal can be arranged mechanically. Existing boiler plant that is hand fired may be converted for use with mechanical stokers, the system depending upon the type of plant installed.

The various systems of mechanical solid fuel stoking described, having been designed to fire the cheaper grades of bituminous and anthracite fuel, make for economy in fuel costs and reduce labour costs. Improved efficiency of combustion and more rigid control of heat output also contribute to economy.

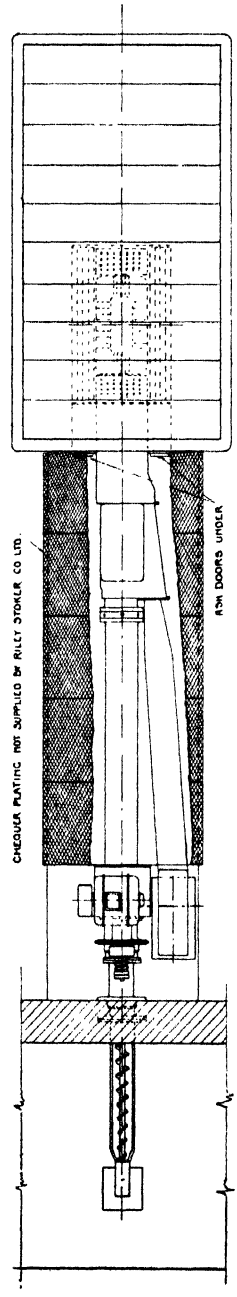
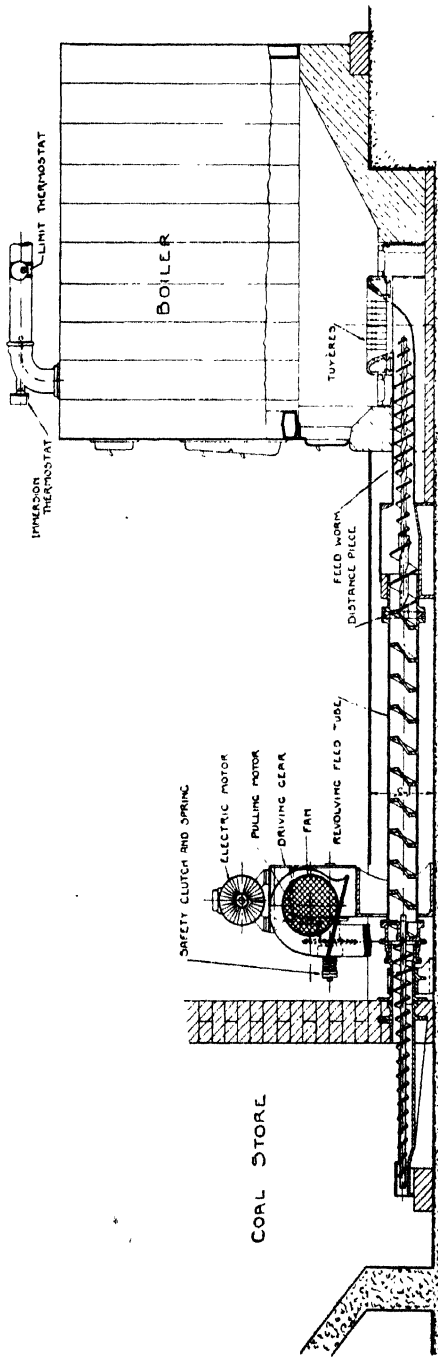

FIG. 44B. SCREW TYPE UNDERFEED STOKER (BUNKER TYPE)
 (Riley Stoker Co., Ltd.)

5. Operational Instruments. Reference has been made to the necessity of obtaining information relating to the performance of an installation in order to assess its efficiency both in heat production and distribution. Unless information of this nature is made available both for the maintenance of records and for the guidance of the plant operatives, few precautions can be taken to prevent the considerable waste that can occur in fuel consumption and unsatisfactory service from the installation generally.

The quantity of excess fuel that may be consumed, depends, amongst other factors, upon the size of the installation, and it is this factor that determines the equipment required. For this reason only installations of considerable output can justify the use of a complete range of instruments. They may be divided into four classes as follows—

1. Indicating.
2. Recording.
3. Integrating or counting.
4. Any combination of the above.

Operational instruments provide information concerning heat distribution in addition to production, and afford a means of checking the regulation of heat output. They also serve to prevent uncomfortable temperatures of a high or low degree, and can, therefore, be used to maintain better conditions of atmospheric comfort in buildings.

To secure economy in the distribution of heat for central warming purposes, its output should balance the quantity actually needed to provide the service required. To maintain a reasonably accurate balance in this exchange of heat when the output from boilers is manually controlled, it is desirable for the prevailing out-of-doors temperature to be shown by a thermometer dial positioned in the vicinity of the boiler thermometers. This arrangement, by facilitating a ready comparison for the maintenance of correct differentials in external and boiler temperatures enables the attendant to avoid both excessive and inadequate temperatures in a building and so reduce the wastage of fuel and increase the standard of comfort. To show the external temperature a distant indicating thermometer may be used, but one of the combined recording and indicating type for both external and boiler temperature will prove more satisfactory as it enables a continuous check to be made of the accuracy of control. An instrument of the recording type is seen in Fig. 45.

To facilitate the general operation and maintenance of plant in the distribution of heat and fresh air throughout a large building, the temperatures and humidities maintained in selected positions in the building or circuits of a system require to be known in the boiler house at frequent intervals. Information of this nature not only provides a means of ensuring accurate manual control of subsidiary apparatus, but verifies the performance of automatic devices



FIG. 45. RECORDING THERMOMETER

A double thermograph type instrument providing simultaneous records of two different temperatures.

(*Cambridge Instrument Co., Ltd.*)

installed for the remote or zone control of temperatures. Electrical instruments of different kinds are installed for transmitting and indicating or recording such information. One method that may be used to indicate relative humidity is shown in Fig. 46.

For economy in the generation of heat a high thermal efficiency of the boiler plant must be maintained, and to secure this a close control of the conditions producing fuel combustion is of primary importance. On the overall thermal efficiency of the plant depends the need for instruments to analyse, adjust and maintain proper conditions of combustion (see Section 3 of Chapter X).

The instruments necessary to determine, for hot water boiler plant, the ratio of useful heat produced to that of fuel consumed include a water meter and water temperature recorders, or alternatively a heat (B.Th.U.) meter, the installation connections of which are shown diagrammatically in Fig. 47. A fuel meter may be used instead of a weighing machine when the boilers are mechanically fired. For steam boilers a feed water meter and thermometer, steam pressure recorder and fuel meter are required to obtain the evaporative efficiency of the plant. As an alternative to a water meter and steam pressure recorder used in conjunction with locked

blow-down cocks, a steam volume meter may be employed to prevent faulty operation of the plant and to provide greater accuracy. The water meter may be of the rotary vane, venturi or other pattern according to the degree of reliability required.

Failure of the plant to provide the efficiency to be expected under

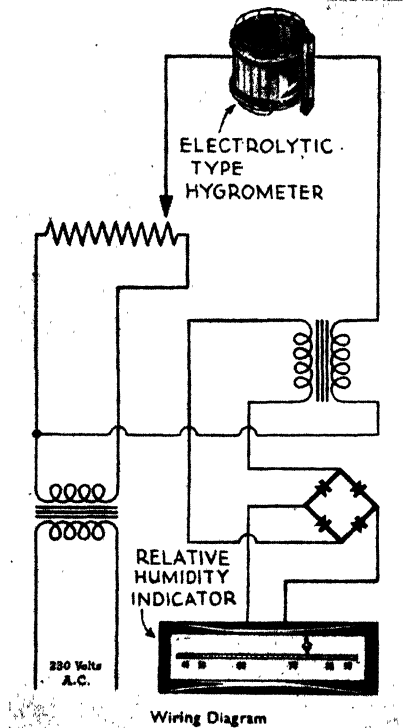

FIG. 46. RELATIVE HUMIDITY INDICATOR

The Gregory hygrometer element is also used for recording and controlling purposes.
(Negretti and Zambra)

average conditions of use, as shown by the instruments described, indicates faults mainly in connection with combustion, and to detect such faults additional instruments are necessary.

The quantity, quality and temperature of flue gases determine the efficiency of combustion, and this makes it necessary to avoid an incorrect ratio of air supply to fuel consumed. A faulty relationship between these is the chief cause of low combustion efficiency in the operation of a plant. The quantity of air supplied to a furnace must be neither excessive nor deficient. The use of a

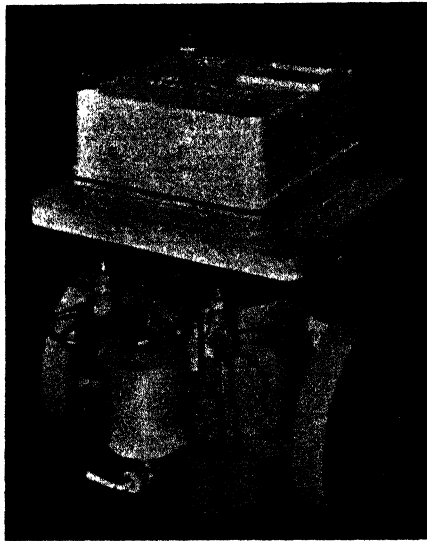
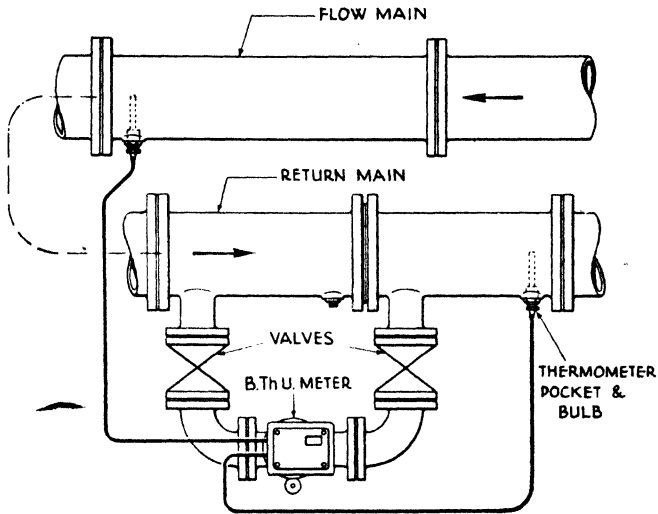

FIG. 47. HEAT METER

The diagram shows the method of installing the meter.
(Kent)

draught gauge therefore, is necessary to ascertain the pressure of gases passing through the boiler and chimney and to check accurately the volume of air supplied for combustion. The gauge may be of the portable or permanent fixture type and preferably of inclined or dial pattern as shown in Fig. 48.

Since the flue gas temperature is a further indication of boiler efficiency, it is desirable for a thermometer or pyrometer to be used as a means of counter-checking the conditions obtained by the draught gauge.

Chemical analysis of the flue gas is the ultimate means of checking combustion conditions. To obtain this information, in which the proportion of carbon dioxide gas present is of greatest importance, a CO_2 indicator or recorder must be used, according to whether intermittent or continuous records are required. For periodic checking purposes, portable apparatus such as the "orsat" chemical exchange or the electrical type may be used, whilst to obtain continuous records instruments of the chemical electrical recording pattern are installed.

FIG. 48. DIAL DRAUGHT GAUGE
(Cambridge Instrument Co., Ltd.)

The desired combustion conditions having been determined by the use of a flue gas CO_2 indicator and thermometer, the adjustment of air supply may be made accordingly and the draught gauge used as a permanent means of stabilizing combustion conditions according to the circumstances under which the plant will have to operate. Such an arrangement as this is to be recommended in those installations where the size does not justify the cost of a full range of instruments.

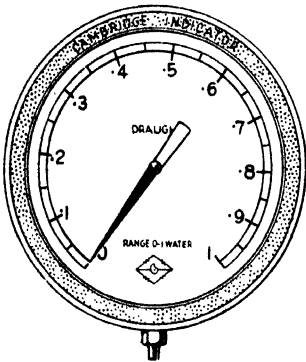

AUTOMATIC TEMPERATURE CONTROL APPLIANCES

1. Reasons for their Use. To ensure the greatest economy in the operation of a heating installation it is not only necessary to be able to use a low-priced grade of fuel and to consume it efficiently, it is also essential to regulate the amount of heat transmitted throughout a building in accordance with the quantity actually required at any given time. To achieve this successfully the control of heat must be effected automatically at its source of supply, supplemented as necessary during the course of its transit for distribution, or at its point of emission to the atmosphere by methods later explained.

Prevention of waste in the use of heat achieves a further purpose in the avoidance of overheating of a building, and in making this possible by the use of automatic control a means is also provided to avoid underheating. Thus the needs of economy and comfort are both served simultaneously.

The necessity of carefully regulating the quantity of heat produced from a boiler plant will be readily appreciated when it is known that the average quantity required from a plant throughout the winter represents little over half its full output. The remaining boiler power is needed only at those times when the external temperature falls below the average of approximately 43 deg. F. experienced during a normal winter season in this country (45.6 deg. F. at Greenwich). On this account there is a strong tendency to operate a plant to give an output of heat in excess of that required, and in actual practice this excess is often found to be considerable unless precautions are taken for its avoidance.

Automatic control provides a balance between the quantity of heat given off by an apparatus and other sources with that transmitted through the building structure and lost by ventilation. Inequality of heat supply and demand in a building is due principally to fluctuations in weather conditions since the outside temperature may vary as much as 30 deg. F. from day to day. Some positive method is necessary, therefore, to adjust these differences in external and internal temperatures, and it is the function of automatic control to compensate for these changes by the use of self-acting regulating devices.

The economic significance of securing continual and accurate control of the heat output from an installation is to be seen in its effect upon fuel consumption in particular. As structural heat losses from a building vary almost in direct proportion to the temperature difference between the internal and external atmospheres, an excess inside temperature of one degree above 63 deg. F., when the

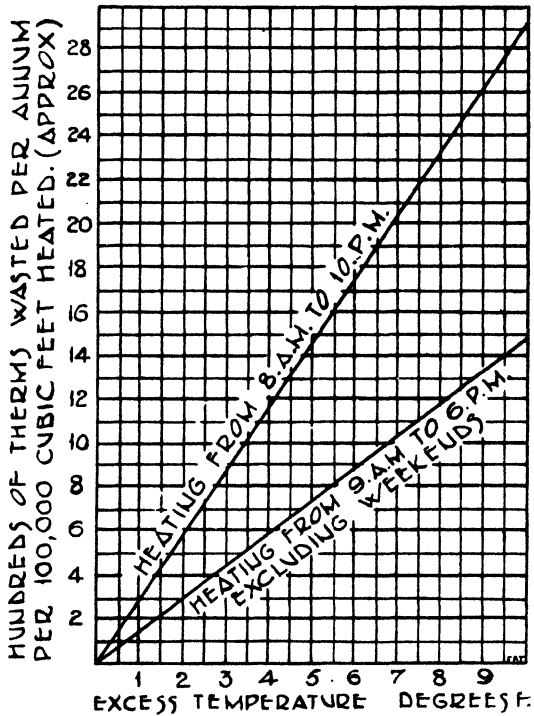

FIG. 49. EXCESS TEMPERATURE CHART

An indication of the quantity of heat wasted by the maintenance of excess temperature in a building with average heat loss.

outside temperature is at the average of 43 deg. F., will represent an additional expenditure in fuel of 5 per cent.

The chart shown in Fig. 49 illustrates the economic advantage to be gained by effecting accurate control of the temperature maintained in a building. The quantities of heat wasted as a result of excessive temperatures are those occurring in an average class of building with natural ventilation and are increased when this is mechanically produced. The equivalent monetary loss will, of course, vary according to the purchase price or productive cost of the heat.

Experience has shown that manual control cannot generally be relied upon to regulate heat output within reasonably close limits owing to the vagaries of the English climate, and in order to obtain economy approaching an optimum figure, combined with equable air temperatures within a building, the human element must be eliminated as much as possible. The boiler attendant cannot be expected continually to readjust the boiler temperature in inverse proportion to the changes of outside temperature with any degree of accuracy, or the occupants of a room to close a radiator valve in preference to opening a window to lower the temperature.

Fluctuation of the external temperature is the main cause for employing some positive method of regulation in heat output to maintain constant temperatures within a building, but there are other contributory causes requiring the use of such a method, as will be seen by reference to the thermograph chart shown in Fig. 50. Solar radiation will affect the amount of heat to be provided in a building, as also will wind, rain, or snow. Internal influences, such as the amount of bodily heat given off by the occupants, and lighting, cooking or any other incidental processes carried out, also affect the temperature inside a building. All these factors must be taken into consideration if ideal conditions of temperature are to be constantly maintained within a building.

Other circumstances in which automatic control can be effectively used are in the arrangement of the plant itself. Its use, for example, is applicable with combined systems of heating and hot water supply when the same boiler, or battery of boilers, is used to serve both apparatuses. It has been a common practice to install this type of system, regardless of the fact that during frequent periods of operation a different temperature is required for each purpose, and the apparatus should, therefore, be provided with the necessary means of automatic control to fulfil each requirement when justified by the capacity of the plant.

Low temperature radiant panel systems, working in conjunction with a boiler plant serving hot water supply apparatus, are normally provided with controls and equipment to reduce the water temperature automatically from that necessary for hot water supply purposes and maintain it at the lower temperature for circulation through the panels. For combined systems using panels or radiators of higher temperature a similar arrangement is needed to vary the flow temperature automatically to these appliances when they are not provided with independent automatic control.

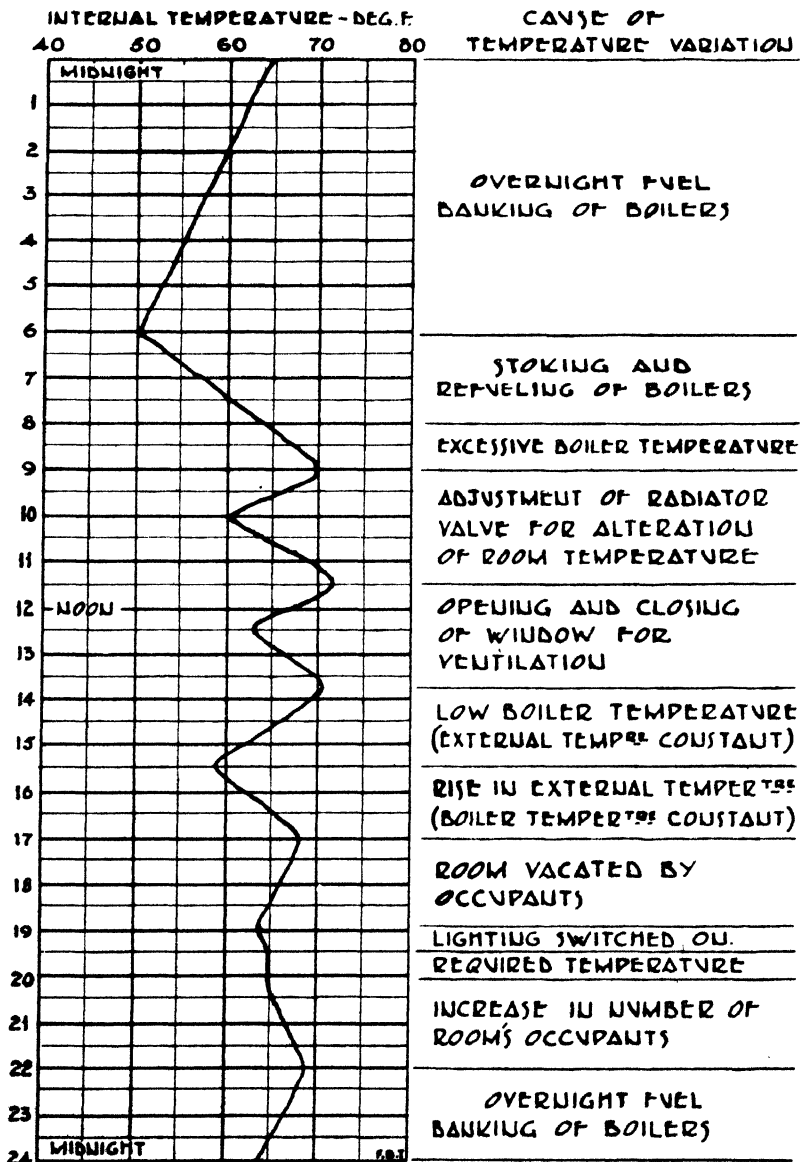

FIG. 50. INTERNAL AIR TEMPERATURE VARIATION

Thermograph chart showing the changes in room temperature that can occur with boiler plant and space-warming appliances hand controlled, and the probable causes of the temperature variation.

There are many other circumstances in which other forms of automatic control are either essential or can be made to improve the operation of plant. The production and maintenance of a correctly humidified atmosphere, for instance, makes it necessary to maintain automatically a close control of conditions in the humidifier and the building itself.

It is interesting to compare the performance of installations

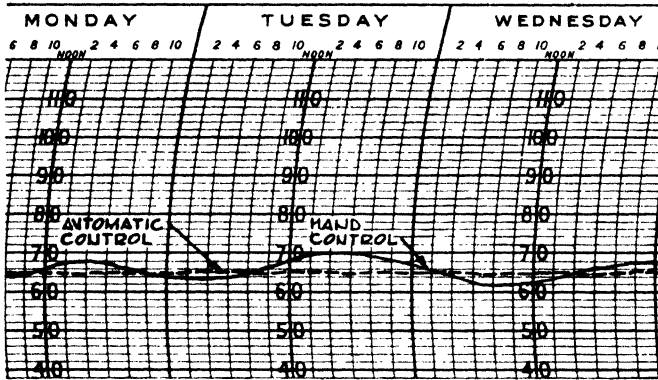

FIG. 51. THERMOGRAPH CHART
Space temperatures with and without automatic control.

provided with automatic means of temperature control and those dependent for control upon hand regulation. The temperature recording graph shown in Fig. 51 denotes the wide variation of temperatures maintained in these circumstances, indicative of the excessive heat output, and the lack of constant conditions of comfort that can occur from the installation operated by hand regulation.

2. Alternative Methods. All methods of automatic temperature control depend for their operation upon the functioning of a thermostat, which acts as a primary controlling mechanism. In order to gain a better understanding of the alternative methods to be described, it should be known that the thermostat used, in so far as it applies to the methods that follow, is of the immersion, surface or air type according to whether it is actuated by the temperature of water or steam, or the ambient atmosphere. Examples of the latter type are shown in Fig. 52.

The thermostat is an automatic device for the conversion of temperature change into mechanical movement for the purpose of maintaining by various means thermal equilibrium between heat

input and losses. Amongst the uses made of this instrument, which may be aided by the thermionic valve as necessary, are the control of the action of electrically-operated magnetic, motorized or capsule-actuated valves, or pneumatically and hydraulically actuated diaphragm valves or dampers on heat distributing circuits and heating appliances, and the control of electric motors for draught regulators or unit heater fans. Thermostats are also used for direct

attachment to dampers, to operate electric contactors and valves for controlling immersion heaters, automatic stokers, oil fuel and gas burners, and also in differential mechanism to co-ordinate changes in external air temperature with that of the boiler flow temperature.

The alternative methods of control available may be broadly classified as follows—

Centralized (boiler plant) control.

Zone (regional) control.

Remote (independent) control.

Any of these methods may be used independently or in conjunction with the others according to the circumstances, and may be applied to control the heating medium according to the air temperature within or outside a building.

The centralized method is applied

direct to the boiler house or other central plant in various ways for the purpose of controlling its output either for warming or cooling requirements. Its simplest form is that used to limit the boiler temperature by a thermostat actuating the boiler damper by direct attachment. Other instances where control is effected centrally are provided by the operation of stokers, oil and gas burners.

The thermostat may be used as a temperature-limiting safety device and to vary the temperature of the boiler flow water or steam when the thermostat is adjusted by hand according to requirements. To avoid re-setting the thermostat by hand the heat output from boilers or calorifiers can be automatically readjusted according to changes in outside temperature by means of compensating devices

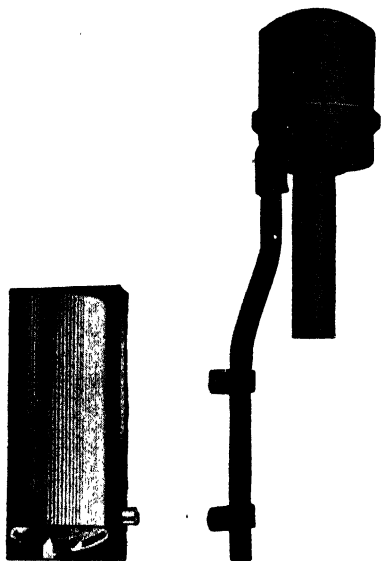

FIG. 52. AIR THERMOSTATS
 Right: Outside Weather Thermostat.
 Left: Inside Thermostat
 (Rheostatic Co., Ltd.)

of the kind previously mentioned. One method utilizing this form of control is shown applied to heating calorifiers in Fig. 53.

Other forms of centralized control include the room thermostat

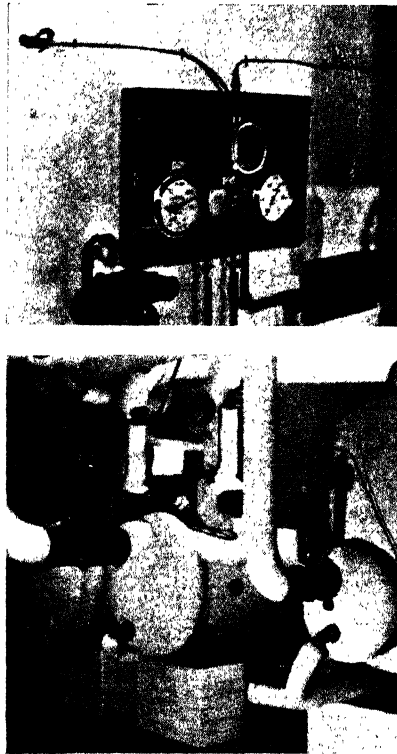

FIG. 53. THERMOSTATIC CONTROL OF HEAT OUTPUT FROM CALORIFIERS ACCORDING TO EXTERNAL TEMPERATURE

Above: Compensator (Variostat), centre instrument, with connections to outside and immersion bulbs and to steam input control valve.

Below: Heating calorifiers showing automatically-operated valve on steam supply controlled by compensator.

which may be used in conjunction with stokers or oil fuel burners to limit the amount of heat produced in accordance with the temperature required in the rooms of buildings of limited size. Similarly, for limiting the relative humidity within a close range, a humidistat or hygrostat is situated in the conditioned space and controls the mixing and stop valves on spray pump and calorifier circuits.

For automatically reducing and maintaining a constant water flow temperature for certain types of radiant panels systems working in conjunction with hot water supply, an immersion thermostat is

used to actuate a modulator or mixing valve interconnected between the flow and return circuit mains. The working of circulating pumps may also be automatically controlled in certain circumstances to vary the amount of heat distributed. To shut down heating systems automatically at night time, during week-ends or any other period, time switches may be used.

The zone method of control is designed to function principally

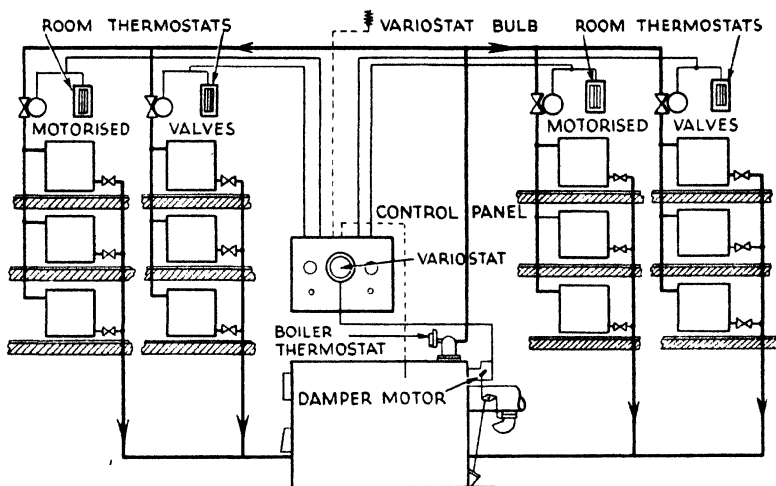

FIG. 54. ASPECT OR ZONE CONTROL

Variostat or climate controller gives general control of heating of building. Zone thermostats control sections of system according to prevailing temperature.

(Thermocontrol Installations Co., Ltd.)

in buildings which possess a number of exterior aspects of some considerable area, each of which is thermally affected differently, according to its exposure to climatic changes. Changes in the direction of the sun, wind and rain, result in varying temperatures of rooms adjacent to these aspects, and to compensate for the effect produced the heat input to these rooms is automatically apportioned. This is effected by sectionalizing the circulating mains to enable each group of rooms to be served by a separate circuit. A regulating or mixing valve fixed in each circuit is controlled by its respective "weather" thermostat or other type of controller, so that the quantity of heat supplied to each group of rooms is commensurate with actual requirements.

Other forms of zone control may be used combining a climate controller or variostat with room thermostats as shown in Fig. 54.

Zone control may also be used when it is desired to maintain certain regions of a building at temperatures different from the remainder, as may be necessary in some classes of premises which are air conditioned.

The remote control method, by virtue of its independent nature, ensures that the temperature of a room or department of a building is automatically modified according to both external influences and the particular conditions prevailing in the space itself. Control of this description is, therefore, able to counteract not only the effect of changes in external temperature and of the building aspect, but also the effect produced by local incidental internal influences such as bodily heat emission, ventilation, and heat given off by lighting and cooking. This method also maintains any constant degree of temperature that may be deemed desirable by individual personal pre-selection.

Remote control is used in conjunction with individual space heating appliances, or individual circuits serving a number of appliances in any one particular room or section of a building. Each appliance or circuit is provided with a valve, controlled by a thermostat, embodied as part of it or separately located in an appropriate position in the room. With this arrangement the thermostat's degree of setting may be readily varied by hand to provide any change in temperature that may be desired.

It will be seen from the description given of the alternative methods of control that the centralized and zone methods of regulation, when depending for operation solely upon changes of the external temperature and other climatic variations, are designed to maintain a general constant temperature throughout a building. No control is exercised by these methods over the particular local internal conditions in different parts of a building, produced by the causes mentioned, unless remote control is embodied.

An exception is that of the centralized method that depends for its control upon the operation of a single thermostat located inside the building and in a position that is intended to be generally representative of the temperature to be maintained throughout. As it is seldom possible with this arrangement to position the thermostat in any one room of a building that is not subject to particular temperature fluctuation due to purely local conditions and, therefore, not typical of general atmospheric requirements, the method cannot be relied upon to produce entirely satisfactory results.

It is clear that the remote method of individual room control is an ideal arrangement but when applied to each appliance its cost can usually only be justified on the grounds of health, comfort and convenience since the saving in fuel alone is not usually sufficient to warrant the expenditure involved for the equipment. This limitation however, is less applicable to non-electrically operated methods of automatic control.

PART III

FUELS, THERMAL INSULATION,
DISTRICT HEATING, HOT WATER SUPPLY,
LOCAL HEATING APPLIANCES, PLANS,
SPECIFICATIONS AND TENDERS

CHAPTER X

FUELS

1. General Considerations. The increased range of raw and processed fuels now available creates problems regarding their efficient use for space warming, ventilation, and hot water supply. These problems are not only for the consumer individually, but concern the nation as a whole since its economic well-being depends upon the conservation of natural fuel resources. In the national interest, therefore, raw coal consumption should be minimized and alternative forms of fuel available for heat production considered. The most advantageous forms of fuel are those that prove most efficient for industrial and commercial purposes, and provide the greatest comfort and convenience for domestic use consistent with economy requirements not always in harmony with national interests. Health and other considerations demand smoke abatement to minimize atmospheric pollution and reduce inland fogs.

These considerations suggest the use of different forms of fuel to meet varying circumstances, such as the period of utilization, quantity involved, method of combustion, application and cost. Frequently, the use of one fuel will be complementary to the use of another. Alternatively, circumstances may combine to prohibit the use of certain types of fuel or future statutory enforcements may preclude their use.

The trend of future applications of solid fuel for domestic purposes is towards processed and carbonized fuels because of their cleanliness, convenience and economy, while for general utility fuels also, there is a greater demand for cleanliness and sizing which gives economy in consumption.

The class of fuel to be consumed, affects both the purchase and operating costs of an installation as well as its general efficiency and the type of equipment to be used for its consumption, and, therefore,

must receive first consideration. There can be little doubt that much dissatisfaction will be caused if extravagant expenditure is necessary for fuel owing to its inappropriate and inefficient use. Indiscriminate selection of both the class of fuel and type of consuming equipment must react unfavourably.

The difficulty in selecting a suitable class and grade of fuel is often intensified as the quantity of fuel involved increases according to the size of the installation concerned. It is unfortunate that fuel, like all other commodities, must follow the economic laws of supply and demand and necessitate compromise in its selection. Stability of conditions of production and supply in the past have rarely been assured for any appreciable period, and, in consequence, qualities and prices have fluctuated from time to time. It seems impossible at present to envisage the future of the fuel industry or make any prognosis of impending changes affecting supplies. To-day, for instance, gas is known to be a by-product of metallurgical coke supply, but it is not difficult to conceive that, in the near future, a reversal may occur as a result of coke becoming a by-product of gas supply, due to the increasing demand for the latter.

It would appear, therefore, that there is little alternative in the choice of a fuel other than to select one according to prevailing circumstances and to avoid future commitments, as far as possible, by not restricting its use entirely to one particular class or grade.

The quantity of heat required in a building will affect, to some extent, the purchase price of the fuel used, and supply undertakings will offer special concessions in this respect if the quantity is sufficient to come within specific rates of supply. An example is that of electrical companies, who are prepared to supply current during daily "off peak" load periods at reduced prices when consumed by heating systems able to utilize a controlled period of supply. The purchase price of gas will also depend upon the quantity to be consumed, although there is no restriction on the periods of supply. Special contract prices for the bulk supply of oil and solid fuel are obtainable in the usual way, but further concessions are sometimes made if the type of plant installed restricts its use to one particular class of solid fuel.

To determine exactly the effective relative value of any one particular class of fuel when consumed under specific conditions is a task of some magnitude involving, in respect of each fuel, considerations of such items as capital charges for plant, its efficiency, maintenance, and depreciation, labour and power required for consumption, and

cost of flues and fuel stores, in addition to the prime cost of fuels itself. It is sufficient, however, in many cases, to assess the relative thermal cost of each fuel according to its purchase price,¹ and also its proximate analysis in the case of certain solid fuels, and to make any adjustments necessary to compensate for plant efficiency and capital and labour costs involved in their consumption.

The proximate analysis of a solid fuel, by revealing, amongst other characteristics, the percentages present of moisture, volatile matter, and ash, enables an assessment to be made of the quantity of heat likely to be lost in combustion due to the effect of these constituents.

The use of a fuel of high initial thermal value and low purchase cost is not sufficient in itself to ensure the minimum cost of operating an installation. Fuel economy must also be assured, and this can be obtained only by the use of equipment that will function efficiently in respect of both the actual combustion of the fuel and utilization of the heat produced. Fuel technology has shown that to obtain only moderate efficiency in fuel combustion, it is necessary to use consuming equipment and instruments that will co-ordinate, at least, the more important factors involved. Similarly, in heat distribution it is essential to control transmission by equipment that will provide the close regulation required by ever-changing conditions.

Conservation of heat produced by the use of particular types and locations of space heating appliances and plant, the application of thermal insulation to apparatus and building structures, and the prevention of waste occurring from exhaustion to the atmosphere or discharge to drains are further means whereby the overall efficiency of heat utilization may be improved with resultant fuel economy.

The use of certain fuels is undoubtedly advantageous in many respects, including cleanliness in use, ease of handling and storage, and efficiency in consumption. Simplicity of plant operation, or its intermittent use, and lack of fuel storage space, are further factors that may influence the use of a particular fuel. The prime factor, however, must remain that of purchase cost, and for this reason solid fuel normally receives first consideration.

2. Alternative Fuels. As a result of the progress made during recent years in the production and utilization of fuels for heating purposes, there now exists a wide variation in the grades available of certain classes and the types of equipment used for their

¹ See Appendix H.

consumption. Circumstances such as these have not only created a diversity in purchase prices, but have also caused changes in the ultimate effective thermal value of particular fuels. It is mainly for these reasons, together with the labour involved for consumption and other incidental factors, that some difficulty may be experienced in selecting a fuel to meet all normal requirements.

Each class and grade of fuel possesses some outstanding characteristic which renders it particularly suitable for consumption under specific conditions, and for this reason the use of each class of fuel for general heating purposes is steadily increasing as its utility becomes more widely known. This increase, however, is due to a large extent to the intermittent nature of consumption, and when continuous use of fuel is necessary, as with central warming and air conditioning installations, restrictions that are mainly economic in character have curtailed the use of the different classes of fuel in general to certain classes in particular.

In addition to economic considerations there are those of convenience and cleanliness, and the use of a particular fuel will therefore often be governed by its ability to meet specific demands regarding supply, storage and consumption. A fuel, for instance, that facilitates delivery, or requires no storage, or is easily accommodated in the space available, or creates the minimum of disturbance for its consumption, may be found especially advantageous when compared with other fuels. The cost incurred in the provision of equipment for its consumption and the desire to limit the amount of attention required in its general use may also prove to be factors of some importance. Whatever the circumstances involved may be, it should become apparent, from the information to follow, how best they can be dealt with in general.

The alternative classes of fuel available are as follows—

Electricity	Coal
Gas	Coke
Oil	Anthracite

Each class of fuel, excepting electricity and gas of the kind that is used for general heating purposes, is divided into a number of grades, according to its source of supply and production process, each affecting in particular its cost of purchase, calorific value and method of consumption.

Electricity, the supply of which is constant at 3,415 B.Th.U.'s per unit, may be utilized at various voltages according to the heating

load concerned. As a form of fuel for central warming purposes it possesses distinct advantages regarding cleanliness, owing to the absence of combustion and flue gases. This feature obviates the need for a chimney stack, and fuel storage accommodation is likewise unnecessary. It also reduces the risk of fire and minimizes the attention required for plant operation.

The use of electricity facilitates the control of heat input to an installation due to more positive means of regulation, and losses are avoided in the process of its conversion into heat. Its purchase cost, which may be affected by the quantity consumed and times of supply, is naturally relatively high owing to its being a derivative of coal and its method of distribution. This factor often prohibits its use as an alternative to other fuels.

Gas as a fuel for central warming apparatus provides an alternative to electricity when it is desired to obtain advantages that are similar respecting the method of supply. The calorific value of this fuel varies to some extent, an average figure being approximately 500 B.Th.U.'s per cubic foot. These declared values are normally constantly maintained within close limits. In its consumption, which is rendered fully automatic as with electricity, a high thermal efficiency can be maintained. Comparatively little attention is required for the maintenance of equipment, and with certain systems of combustion the boiler plant may be converted for use with other fuels.

Oil fuel¹ of the light and medium grades (40—70 and 200 secs. viscosity, Redwood) has a calorific value of approximately 19,000 and 18,500 B.Th.U.'s per lb. respectively, and requires a space of about 40 cu. ft. for the storage of one ton. Owing to its fluidity, oil fuel is compact to store and convenient to unload and convey to storage positions and to the boiler plant, and on this account may prove advantageous when site conditions prevent access for the discharge of solid fuel. Its consumption, which is either fully or semi-automatic according to the size of installation and type of fuel used, approaches a relatively high efficiency, but it is not always entirely odourless in use. The purchase price varies according to grade and quantity but cannot be low for an imported fuel.

Coal is a fuel possessing constituents that vary according to the district in which it is produced, and on this account its calorific value also varies from about 11,000 to 14,000 B.Th.U.'s per lb. The space required for storage is approximately 50 cu. ft. per ton.

¹ See Appendix F.

In the use of a solid fuel for any specific purpose, due regard must be had to its composite properties. Such constituents as volatiles, fixed carbon, moisture and ash content, together with the fuel's caking properties, grading and cleaning, will affect the results obtained in combustion. They will also be affected by the method of firing used. Different grades of this fuel are available for use with alternative methods of consumption, enabling it to be efficiently consumed by various systems of stoking.

Bituminous coal fuel when hand fired may require frequent and constant attention to obtain a reasonable efficiency in combustion, owing to its coalescent properties. When consumed in this way it lacks cleanliness. The use of mechanical systems of firing and stoking, not only renders the consumption of coal automatic or semi-automatic in a similar manner to other fuels, but also provides a means of attaining a high thermal efficiency in the process. The purchase price of coal depends to some extent upon the method of firing used as this determines the type of fuel required.

Coke is a class of processed smokeless solid fuel that is used extensively in central warming apparatus because of its particular characteristics. Its average calorific value is in the region of 12,000 B.Th.U.'s per lb., and the space required for storage is about 90 cu. ft. per ton. This fuel, which includes the furnace, gas or low temperature varieties, being of low volatile content, produces steady conditions of combustion during infrequent boiler charges, and on this account proves advantageous for general use with various types of installation. It is normally hand fired, but its consumption can be rendered automatic by the use of the appropriate boiler plant. The fuel is obtained at a medium purchase price, with a choice of five sizes.

Anthracite, as a smokeless fuel for central warming, may be regarded as a convenient alternative to coal and coke when consumed in those districts where it is produced and when fuel storage space is restricted. The calorific value is approximately 14,000 B.Th.U.'s per lb. and approximately 45 cu. ft. is required for the storage of one ton. This fuel, requiring adequate draught for combustion, cannot always be hand fired under similar conditions to that of coal or coke, but when consumed in this way will burn for long periods without attention, owing to its density and low volatility. Anthracite may be consumed by both automatic and semi-automatic means according to the degree of convenience required. Its purchase price is affected in much the same way as that of coal.

Owing to variation in composition, production and combustion

of a fuel, and in the transfer of its heat, and other factors (including purchase price), the cost of obtaining useful heat from fuel for transmission to the various parts of a building fluctuates accordingly. Some indication of this cost variation may be obtained from Table VII which is given to obtain a fuller understanding of what is involved in the selection of a fuel rather than for the purpose of making an approximate comparison. To ascertain the actual cost of providing heat in a building with any one particular fuel, appliance and system allowance must be made for any extra expense incurred for such items as distribution losses, labour, incidental power, maintenance, interest, depreciation, and insurance.

TABLE VII
RELATIVE FUEL COSTS

Fuel and Thermal value ³	Method of use	Appliance Efficiency ¹ per cent	Optimum cost ² in pence per therm with fuel at prices ³ as under			
Coal at 12,000 B.Th.U.'s per lb.	Hand-fired Automatic stoker	50-70	40/- 2.5	50/- 3.2	60/- 3.8	per ton
		65-80	2.2	2.8	3.4	
Coke at 12,000 B.Th.U.'s per lb.	Hand-fired Magazine boiler	55-70	70/- 4.5	75/- 4.8	80/- 5.1	per ton
		65-80	3.9	4.2	4.5	
Anthracite at 14,000 B.Th.U.'s per lb.	Hand-fired Gravity feed burner Magazine boiler	55-70	80/- 4.4	90/- 4.9	100/- 5.5	per ton
		65-80	3.8	4.3	4.8	
		65-80	3.8	4.3	4.8	
Fuel oil at 19,000 B.Th.U.'s per lb.	Fired in boiler	65-80	80/- 2.8	120/- 4.2	160/- 5.6	per ton
Gas at 100,000 B.Th.U.'s per therm	Fired in boiler	70-85	8d. 9.4	10d. 11.8	1/- 14.1	per therm
Electricity at 3,412 B.Th.U.'s per unit	Thermal storage	95	0.45d. 13.9	0.50d. 15.4	0.55d. 17.0	per unit

¹ The actual efficiency obtained will depend upon the equipment selected, the care taken in its operation, and upon working conditions.

² Costs will be subject to a small decimal increase to include the items, when applicable, mentioned in the paragraph above table, which determine the ultimate cost of heat in the space warmed.

³ Figures to be adjusted as necessary.

A significant feature of this table is that which shows the necessity of using fuel in an appliance that ensures a good efficiency and the essential need of maintaining this by the proper functioning of the appliance under working conditions.

The purchase price of each class of fuel will vary to some extent according to the locality, the quantity supplied and other causes, and to compensate for this, adjustment can be made to the costs given in Table VII on a plus or minus percentage basis.

3. Fuel Economy. The proper quantity of fuel consumed to provide the atmospheric conditions required in a building is largely dependent upon the operating economy obtained in the functioning of an installation. It is therefore necessary for precautions to be taken to prevent waste in both the generation and transfer of the heat available in the fuel and in its subsequent utilization. If this is to be successfully achieved, the principal economic factors involved in the process must be taken into full account.

It has already been noted that the primary economic factor in the production of heat is the effective thermal cost of the fuel used as determined on a basis of comparison of the purchase price of different fuels, together with the methods used in their consumption. The purchase price is already sufficiently controlled, and control of the quantity of fuel consumed is mainly a matter of extracting the heat and making it available for distribution in the most efficient manner. Most of the losses of heat are dependent upon the combustion and heat transfer efficiency of the fuel and boiler.

It is sometimes assumed, when selecting a boiler, that its specified efficiency is entirely dependent upon its design and is attained irrespective of the method used to consume the fuel, but in fact the combustion conditions will considerably affect the overall efficiency obtained. In consequence the economical consumption of a fuel will, amongst other factors, depend not only upon the character of the fuel itself and the type of boilers installed, but upon whether the fuel is hand or mechanically fired, and the precautions taken to ensure the maintenance of proper conditions of combustion in the current operation of the plant. These circumstances will entail consideration being given to the actual constituents of the fuel, the use of alternative types of boilers, mechanical firing equipment, and when necessary, the employment of operational instruments.

To obtain and maintain a maximum thermal plant efficiency it is particularly necessary with those installations consuming appreciable quantities of fuel for close control to be exercised over

the operating conditions of the boiler plant. To secure this the relationship of the heat input in fuel to the heat output in steam or water from the plant must be known so that any deficiency may be detected. To determine what ratio this may be in the case of steam plant, the quantity of fuel consumed, together with the

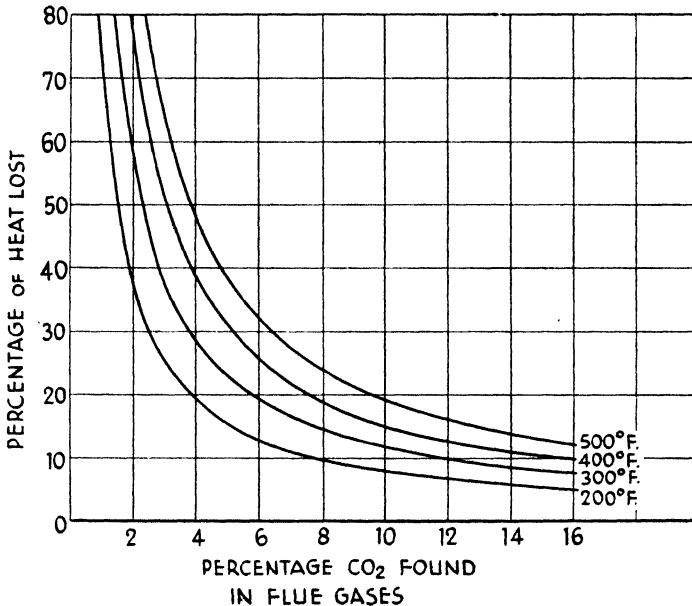

FIG. 55. HEAT LOSS IN FLUE GASES

Chart showing the relationship between the percentages of carbon dioxide in the flue gas and the heat loss due to excess air at four different flue gas temperatures.

amount of boiler feed water used and its temperature, and the pressure of the steam made available must be ascertained. Alternatively, the quantity and pressure of the steam produced in relation to the amount of fuel used and the feed water temperature will serve the same purpose. For hot water plant, the quantity and rise in temperature of the water circulated, together with the amount of fuel consumed, must be made known.

Discrepancy between the thermal efficiency actually obtained with a boiler plant and that possible as disclosed by the methods described above, primarily necessitates corrective measures being taken in connection with the temperature and composition of flue gases from the boilers. These characteristics of the gases, which require to be known in order to verify combustion efficiency, will in turn

be influenced by boiler draught, the extent of which must also be known since this affects the quantity of air admitted to the boiler. An indication of the heat losses that occur owing to excess air is given in Fig. 55.

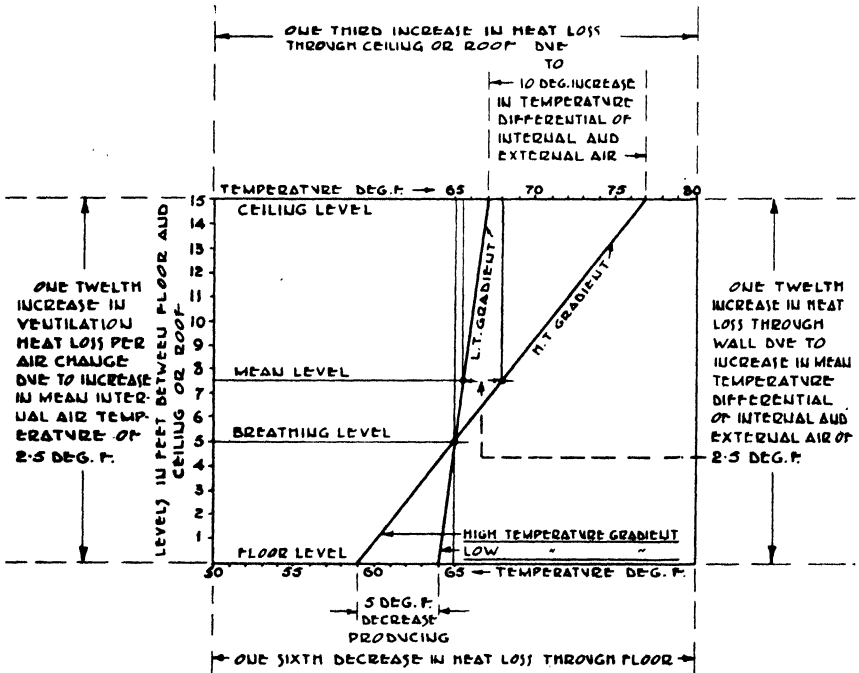

COMPARATIVE HEAT LOSS BASED ON 30 DEG. F. TEMPERATURE RISE

FIG. 56. HEAT LOSS AND TEMPERATURE GRADIENT

Diagram showing the causes of heat loss increment in a building due to temperature gradient (assumed to be represented by a straight line for purpose of illustration).

The means of providing this information, together with that previously mentioned in regard to verifying the overall thermal efficiency, have been dealt with in the Section relating to "Operational Instruments." In addition, the internal and external condition of boiler plates and tubes, as affected by combustion gas and feed water deposits, will react upon efficiency and necessitate effective control being maintained over these two agents in the operation of plant.

A further factor influencing the economical consumption of fuel, and one of equal importance to the thermal efficiency of the boiler plant itself, is the control of its heat output. It is obviously unsound to save heat by economical methods of production if it is only to be

wasted by extravagant distribution, such as frequently occurs with many installations. It is necessary, therefore, to safeguard against excessive use of heat by ensuring that only the requisite amount is produced for distribution as and when required. This implies that the output of heat must be accurately controlled at the boilers supplemented, if necessary, by control at appropriate points in the circulating mains or at the space heating appliance itself. The method of control must be positive, and for this reason automatic and not manual means should be adopted as described in the chapter relating to automatic control.

The variable control of heat output in itself, however, will not effect total economy in its distribution since this is further influenced by the type of space-heating appliance used and its location. Upon the choice made in this respect will depend, first, whether the atmosphere is evenly warmed or a disproportionate amount of heat exists at the higher levels due to the temperature gradient produced (the effect of which is shown in the diagram in Fig. 56), and, secondly, whether a full air temperature is provided or reliance is placed upon equivalent temperatures produced by means of localized radiation. The recirculation of air possible with plenum and complete conditioning apparatus will also aid economy.

It has been stated that the fuel or power saving resulting from the use of low temperature radiant warming panels may amount to as much as 15 per cent. This economic advantage is claimed because the human body can more readily attain a state of comfort by direct radiant heat than by warm air. This saving is partly attributed to the reduction in thermal losses that occurs by ventilation due to the air not being excessively warmed.

A further instance of how extravagant utilization of heat can be avoided is revealed by the use of thermal insulation. Considerable conservation of heat can be made, after its transmission to the atmosphere, by avoidance of excessive heat loss through the building structure. In the same way heat losses from the installation itself can be minimized by reducing transmission from those parts of the apparatus presenting ineffective heating surface. The use of suitable insulating materials cannot, therefore, be avoided if maximum fuel economy is to be assured.

The location and orientation of a building will also affect the amount of heat required since this varies according to the part of the country in which the building is located, its situation in high or low-lying localities and also its northern aspect exposure.

Combining the generation of electricity with that of the heat required in a building when both are produced at the same site may also provide a means of reducing overall fuel consumption. The practicability of using this method in a new building will largely depend upon the cost of public supply, the relative loads of the two services, and the ability to co-ordinate them economically to meet demands, in time and quantity, for the electricity and heat required.

Further conservation of fuel supplies may be found possible by investigating the practicability of utilizing any sources of waste heat that may be available. This may be contained in exhaust and flash steam, exhaust combustion gases, manufacturing process vapours, and factory waste material such as timber and oil. Low grade heat may be utilized by the heat pump. The quantity of heat produced from refuse disposal plants is often considerable and may be utilized to advantage when suitable equipment is installed. The quantity of heat that is available and can be effectively utilized by these various methods will determine if the capital expenditure for the installation of the necessary apparatus is justified.

THERMAL INSULATION

1. Value of Insulation. Amongst the many factors that contribute both to the conservation of fuel, and improved conditions of comfort, thermal insulation is one of the most important. Any economies effected by the heating and combustion engineer in the design, installation and use of equipment must, therefore, be supplemented by those responsible for the planning and construction of buildings if full advantage is to be taken of the means available for the efficient utilization of heat. Various means are used to ensure that heat is made available with the minimum of loss, and it is therefore necessary to consider the alternative insulating methods and materials that can be used to prevent excessive heat loss through the building structure and from the heat producing apparatus and distribution circuits for the benefit of the building owner, the occupants, and in the national interest.

The enforced economies that were necessary during the war to conserve fuel supplies to the utmost emphasized the importance of providing adequate thermal insulative treatment in various ways, and especially in the construction of buildings. As an ultimate sequel to the importance attached to this subject it is possible to envisage a national fuel policy legislating a maximum thermal transmittance through building structures. Meanwhile there seems to be no reason why a house, for example, should not be built with a guarantee that it will require no more than a given number of heat units for a standard degree of comfort throughout a year of average weather.

It is only by ascertaining the effect produced by the different methods available that it is possible to strike a careful balance between the saving to be made in the cost of heating apparatus and fuel and the extra cost incurred in constructing a building with better insulation. An example of the variation that occurs in thermal loss through building structures according to the form of construction used is given in the chart in Fig. 57.

The use of thermal insulating material serves many other purposes in addition to conserving heat. A well-insulated building, in reducing heat losses through its structure, which may curtail the fuel required

to less than half the quantity otherwise necessary, also lessens the cost of the heating apparatus to be installed since its capacity can be less owing to the smaller quantity of heat required from it. On this account it is found, in connection with certain forms of building construction, that the saving that can be made in the cost of providing heating apparatus is sufficient to cover the cost of supplying and fixing the structural insulating material.

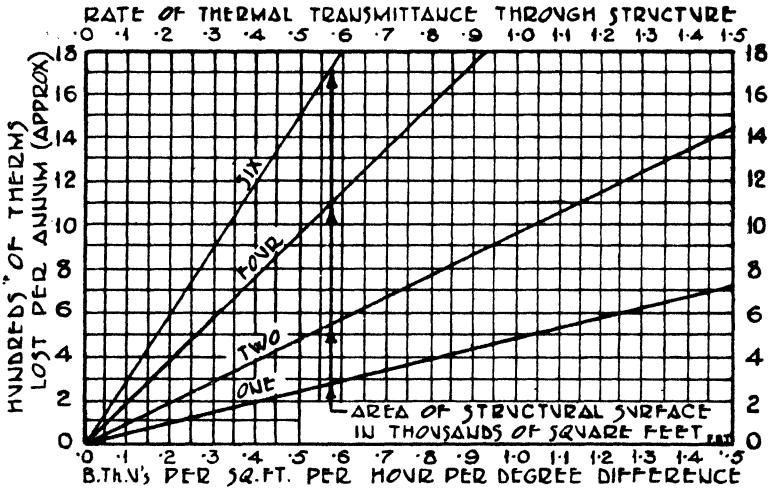

FIG. 57. THERMAL LOSS THROUGH BUILDING STRUCTURE

The above chart serves to illustrate the variation in approximate structural thermal losses that occur in a building according to the degree of insulation provided by the different forms of construction given in Appendix A.

Insulation also reduces the period necessary for warming up a building, thus achieving further economy in both initial and operating costs of an installation. Moreover, condensation on walls and ceilings or roofs, which is caused by their surface temperature being below that of the dew point temperature of the atmosphere can also be avoided by materials of high thermal resistivity and low volume specific heat. The lower the thermal capacity and conductivity of the material used, the shorter will be the heating up period necessary and the higher will be the relative humidity permissible before precipitation of moisture occurs.

The extensive use now made in building construction of the flat roof calls for more careful treatment in its insulation against the transmission of heat, because smaller protection is afforded as compared with the traditional style of pitched roof with slates or tiles.

When insulation is applied to the back and sides of a fireplace, not only is the heat loss reduced but the radiant efficiency is increased.

Whatever purpose is served incidental to the main object of using insulation, it will be appreciated that in assisting to keep the building warm in winter, the insulation also keeps it cooler during summer time, and on occasions serves as an insulator of sound and moisture.

The use of insulation is of particular significance when a building is heated by an expensive fuel, and may well prove to be the deciding factor in the application of direct electrical heating. In contemplating such a method of warming it is, therefore, essential to consider its practicability in conjunction with the fullest use of insulation if this form of fuel is to compete with others less costly.

As is well known, the transmission rate of heat through a material depends, amongst other factors, upon its thermal conductivity, which will vary according to the material, its form of composition and method of assembly. In the choice of suitable materials for insulating purposes, these features will therefore govern the character of the insulation used. Since the nature of the substance itself and the manner in which it is rendered together to form a composite mass affect the thermal conductivity of the material, its insulating value or efficiency will vary accordingly. Thus, for example, a material of poor conductivity that is also constructed in cellular formation and erected with a cavity containing static air—which itself is a poor conductor—is found to give added resistance to the passage of heat by conduction. When such material is provided with a polished finish to its surface, the quantity of heat radiated from it or absorbed by it will also diminish, thereby further increasing thermal resistance. See Table VIII for conductivities.

Materials that are good heat conductors may, paradoxically, be good insulators of heat, as in the case of aluminium. This is evident when the material acts as a reflector of radiant heat and is used in the form of foil fixed in a static air space.

The economic value of an insulating material may be assessed according to the quantity of heat transmitted through it in terms of area, time, temperature difference and cost. Thus, if a certain class of material is known to reduce the transmission of heat through a given area of surface by a particular number of B.Th.U.'s when produced at a specific cost, and supplied for a particular number of hours during the period of a winter season of so many degree days,¹ the annual saving in fuel cost may be assessed accordingly.

¹ See Appendix G.

TABLE VIII
THERMAL CONDUCTIVITY OF INSULATING MATERIALS

Material	Thermal Conductivity (<i>k</i>) (B.Th.U.'s per sq. ft. per hour per deg. F. diff. per in. thickness)
Aluminium Foil	0.21
Slag Wool	0.30
Wood Wool Slab	0.58
Asbestos Felt.	0.35-0.50
Glass Fibre	0.22-0.28
Sawdust	0.41
Cork --Granulated	0.33
--Slab	0.29
Magnesia 85%	0.40-0.54
Fibre Board	0.35-0.44
Foamed Slag Concrete	1.7-1.9
Clinker Concrete	2.3-2.8

Calculations of this nature show that the cost of supplying and fixing insulating material in a building can be recovered by the saving made in fuel costs over a period ranging from about one to five years, the actual time depending upon the class of building structure treated and the insulating material and fuel used. Similarly the saving in fuel cost that can be made by the insulation of circulating mains, and other parts of the heating apparatus, can be determined according to the reduction in heat transmission. The cost incurred for the provision of the necessary insulation is recovered over much the same period as for building insulation.

The class of building material used in the construction of a building by reason of its thermal insulative properties¹ in addition to those of strength, durability and other resistant characteristics should therefore be selected with the object of securing the practicable maximum reduction in thermal loss both by the insulative properties of the material itself and the formation of sealed air spaces.

In the construction of buildings in general the desirable thermal transmittance co-efficient *U* will usually be found to come within the values of 0.15 for floors, 0.15 to 0.30 for walls, and 0.20 to 0.30 for roofs.

The insulation of a building, either wholly or in part, whether it be effected in its form of construction by the embodiment of insulating material as an integral part of its structure, or applied

¹ See Appendix C.

supplementary to the main structure, should be regarded as an essential feature in the construction of every building. On this

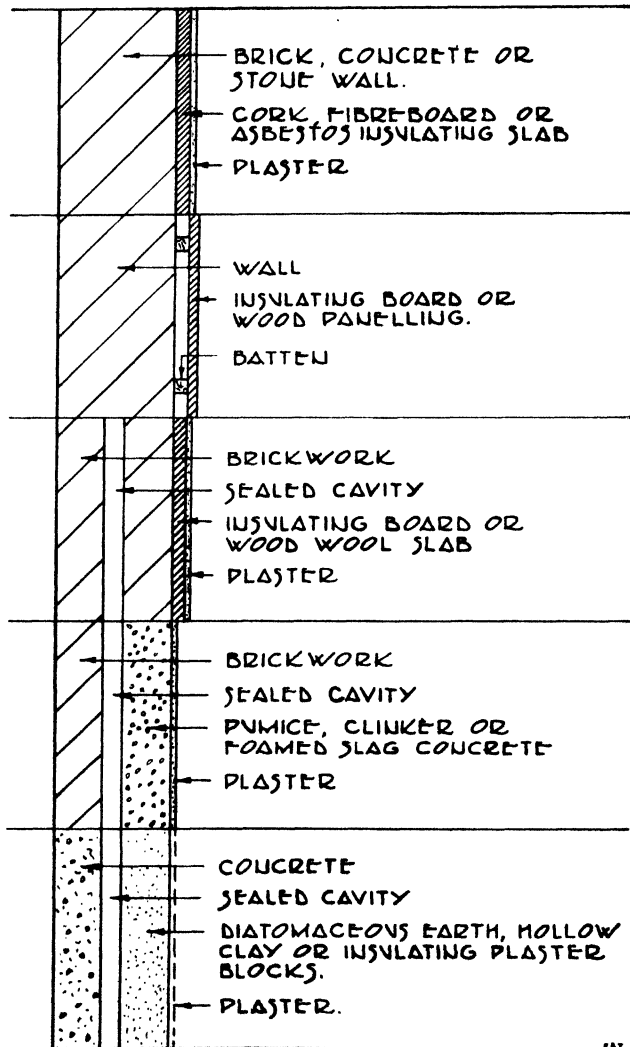

FIG. 58. INSULATION METHODS FOR WALLS

account the question of insulation should receive consideration during the initial stages of building planning so that its form of application may be arranged accordingly.

2. Insulation of Buildings. The methods and materials used for

the thermal insulation of buildings are becoming more numerous every day and present a wide choice for use in a variety of circumstances. Each material possesses advantages in regard to application, strength, durability, incombustibility and resistance to attack from vermin or the penetration of moisture, in addition to its thermal properties, and all these should receive attention. The part of the building to be insulated will govern, to some extent, the method of application and type of material to be used, although there are some forms of material applicable to all parts of a building.

Some of the methods used in the application of thermal insulation are shown in Figs. 58 and 59.

Since the greater proportion of heat lost from the average type of building occurs through the wall structure, it is necessary for this part of a building to receive first consideration. Wall insulation not only diminishes heat loss through the structure itself but also that due to ventilation because it reduces the necessity for an increase of internal air temperature to counteract the negative radiation to cold walls in the same way as warming panels.

The quality of brick used in the construction of a wall is important since its porosity and other composite features affect its insulative value. Special heat insulating bricks may be used if it is desired to obtain the maximum insulation. The thickness of brickwork or concrete, inclusion of cellular concrete or sealed air spaces, and the provision of plaster and other finishes all have some effect, as also will the nature of the finished surface provided. External finishes of stucco or pebble dash, although affording an increase in wall thickness, also increase its superficial area, and in general are of little consequence as an insulator of heat. But the saving that can be made by the application of insulating material to walling is apparent in the example of a finish that can be applied after erection. When this is in the form of wood wool cement of 1 in. thickness, and applied to a 6 in. concrete wall, the heat transmission can be reduced by half.

Other materials that can be applied to walling are cork, fibre-board, asbestos slab, and plywood, and if fixed with an air space they require careful sealing at the joints to avoid crevices for the harbouring of vermin. For this reason air spaces are sometimes better avoided in the residential class of building.

Oak panelling of walls was first introduced more for its insulative than decorative effect, but for the former purpose such panelling is

now being superseded by insulating boards. This class of material, of which there are many varieties available, is particularly suitable

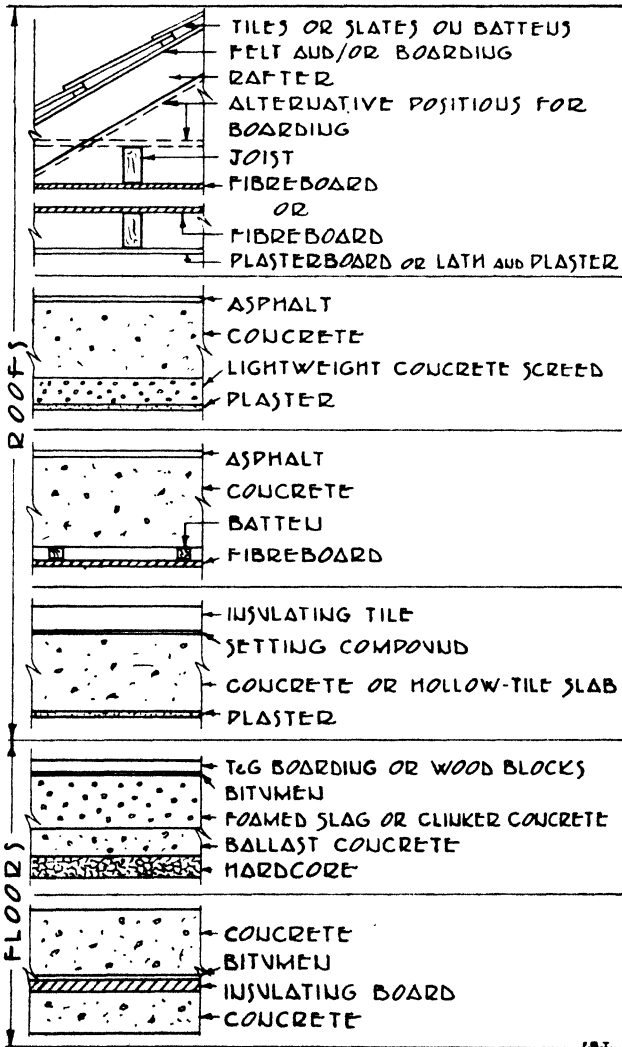

FIG. 59. INSULATION METHODS FOR FLOORS AND ROOFS

for use as linings to walls of corrugated iron or asbestos cement and other semi-permanent forms of construction through which abnormal heat loss occurs, and it will also reduce the warming up period required when applied to brickwork or concrete. Walls of light

construction such as a framework of timber or angle iron with tongued or grooved boarding or sheet metal, which provide an intervening void, can be thermally improved by the inclusion of some form of loose insulative filling such as granulated cork or slag wool, sawdust and asbestos, or by the inclusion of aluminium foil.

A normal standard of insulation for walls can be secured by sealed cavity brickwork, or the use of different classes of concrete of suitable thickness. A combination of structural materials with an air space provides a further alternative.

Windows, being responsible for about a quarter of the heat lost from a room of average planning, should be double glazed whenever circumstances permit. Consideration may also be given to the use of opaque glass insulating bricks or of double or triple glazed sheets with a dehydrated air space for the same reason, and to eliminate misting and frosting from condensation. The provision of heavy curtains and window shutters also reduces thermal transmission during periods of darkness, and, incidentally, converse transmission during summer time in residential buildings in particular.

Windows also cause heat loss by air infiltration and should be reasonably airtight at joints for this reason and to reduce draughts, to which reference is made in Section 3 of Chapter III.

The treatment of roofs in many cases calls for special consideration in view of the poor insulation provided by certain forms of construction causing excessive heat loss through the material and by the infiltration of air. Roofs of the factory class of saw tooth formation, particularly when constructed of corrugated iron or asbestos, are responsible for considerable heat wastage unless treated accordingly. On this account it would appear preferable in many cases to substitute corrugated material by strengthened insulating board provided with a suitable weatherproof finish. The necessity for some alternative form of construction is apparent when it is realized, for example, that the transmission of heat through a corrugated asbestos cement roof can be reduced to about one-fifth of the original loss by the application of $\frac{1}{2}$ in. fibre board lining.

Tiled and slated roofs of dwellings require to be boarded and felted to provide good insulation, and a covering over ceiling joists of suitable insulating material should not be omitted and usually serves as a more satisfactory alternative to extra insulation fixed under the sloping roof. Flat roofs of concrete, hollow tile formation, and similar construction may be overlaid with cork slabs before applying the asphalt finish, or, alternatively, insulating roofing tiles

TABLE IX
RECOMMENDED VALUES OF INSULATION¹

Class of building	U = Overall heat transmittance <i>vide</i> Par. 12	
	Desirable standard of insulation, where heat output cannot be closely controlled	Desirable standard of insulation, where heat output can be closely controlled
<i>Small Domestic Buildings:</i> (Houses and Flats)	U not to exceed	U not to exceed
Ground floor	0.15	0.15
External walls, living room	0.2	0.15
External walls, other rooms	0.3	0.2
Roof and top-floor ceiling taken together—		
Houses	0.3	0.2
Flats	0.2	0.2
<i>Schools:</i>		
External walls	—	0.3
Roofs	—	0.2
Floors	—	0.15

may be used, both forms of insulation being recommended when ceiling warming panels are installed. Insulating board may also be embodied in the construction of flat roofs in the form of permanent shuttering, or may be fixed on battens below the concrete. Insulation applied below the main structure is in general more effective than that applied above.

A simple means of applying insulation to finished surfaces of flat roofs is by the addition of a layer of shingle, the extra thickness of stone, together with the formation of air pockets, restricting the passage of heat. In the construction of flat roofs the finishing material should be laid to correct falls to avoid the formation of pools of rainwater, which, in evaporating cause additional heat loss.

The insulation of floors other than the suspended, ventilated timber joist type is of less importance than other surfaces of a building since they are not exposed to external influences in the same way, and in consequence a lower rate of heat transmission

¹ Extracted from British Standard Code of Practice, No. 309: "Heating and Heat Insulation," by permission of the British Standards Institution, 28 Victoria Street, London, S.W.1, from whom official copies of the specification can be obtained, price 2s post free.

usually occurs through them. The quantity of heat lost, however, will be influenced by the class and thickness of flooring materials used, and in considering constructional details of a building it should be noted that these two factors will affect the degree of insulation to be obtained as well as the structural strength of the flooring, a larger factor of safety of which might be provided for this reason.

Intermediate floors with intermittently heated rooms below should be constructed of surface materials underneath having a low thermal capacity and conductivity for reasons already mentioned and because this is an added advantage in reducing condensation on the ceilings below when changes in temperature occur.

Ground floors that are covered with a finishing material of marble, terrazzo or tile and similar coverings which are comparatively good conductors of heat, and which are provided with a solid foundation, could with advantage have this composed of good insulating material. In thus reducing the transmission of heat, the cold feeling that is usually associated with floors of this description can be ameliorated.

As an indication of appropriate values of insulation those recommended for small domestic buildings and schools are given in Table IX. For buildings in general an accurate evaluation can be arrived at after the fabric heat losses have been determined and an estimate made of the cost of the heating installation and insulation.

3. Insulation of Apparatus. The greater proportion of heat emitted from an installation, other than from the space heating appliances themselves, can be conserved by the use of insulating material. The amount of heat wasted by an uninsulated heating installation is often a considerable quantity, and this may be even greater with a hot water supply installation since the waste continues throughout the entire year, and may represent more heat than that required to warm the water used at the taps. Particulars of the saving that can be made by insulation are given in Table X.

It is principally on this account that those parts of the apparatus not used as effective heating surface should be covered by some form of insulation, but its use is also necessary to reduce the emission of heat from hot water supply apparatus, which may prove objectionable in certain parts of the building during the summer time. A further purpose to be served by the application of insulation, to circulating mains in particular, is a restriction of the effect produced by heat upon unseasoned woodwork in their close vicinity. The deposition of dust from heated air given off by circuits, which causes

TABLE X
COMPARATIVE HEAT LOSSES BETWEEN LAGGED AND UNLAGGED PIPES

	Heat losses per hour per 10-ft. run in B.Th.U.'s		Saving in B.Th.U.'s	Saving in week per 10-ft. run (8·6d. therm., 75% efficiency) in pence
	Unlagged	Lagged		
$\frac{1}{8}$ in.	470	100	370	7
$\frac{1}{4}$ in.	520	115	405	8
1 in.	660	135	525	10
$1\frac{1}{2}$ in.	900	170	730	14
2 in.	1120	205	915	17
Galvanized Tank per 10 sq. ft..	1200	220	980	19

discoloration of adjacent surfaces, can also be lessened by the use of insulation.

Boilers, calorifiers and hot water storage cylinders, in addition to circulating mains, will require to be treated, together with warm and cool air circuit ducting from which excessive heat loss or gain might otherwise occur owing to its exposed position. The insulation of apparatus in the boiler house is especially desirable both for economy and to assist in reducing the excessive air temperature that can prevail in this part of a building unless some means is provided for its avoidance.

The class of insulating material used will depend upon the thermal efficiency required, the method of application desired, durability, and the cost to be incurred. A covering for general utility purposes consists of fossil meal and asbestos, or magnesia composition, which contains good insulating properties, is durable and moderate in cost. Magnesia is the superior insulator of the two, giving an additional 15 per cent efficiency over fossil meal and asbestos. It is applied in the form of a plastic compound to the apparatus when heat is in circulation, and is protected with a hard-setting finishing composition as shown in Fig. 60.

Pipe coverings that provide increased efficiency are those that are obtained already made up in size and shape for application to the apparatus in sectional form, in other words, prefabricated. Materials of this description, which may be constructed in cellular and other formation, consist of such substances as asbestos, cork or glass fibre and aluminium foil. This type of covering, which does not provide for the size and shape of every pipe fitting and is

therefore used in conjunction with plastic composition, is also an alternative form of insulation to be used when expediency in its application is essential.

The insulation of boilers may be effected by the application of

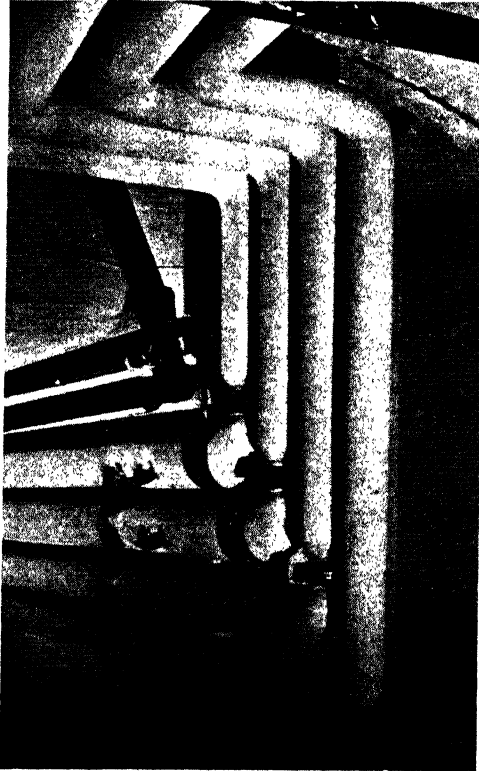

FIG. 60. PIPEWORK INSULATED WITH PLASTIC COMPOSITION

plastic composition direct to the metalwork, or by the use of sheet metal jackets which may be lined with asbestos sheeting or foil to supplement the insulative effect of the air space provided within the casing. The actual form of covering used with boilers will depend largely upon their type.

Insulation that is exposed to climatic conditions, such as that applied to circuit mains on roofs, must be protected with a suitable weatherproof cover. A housing of brick, concrete or tiling affords superior protection for this purpose but as an alternative the

insulation may be finished with a form of rubberized sheeting or a bitumastic coating.

When conditions are such as to warrant the maximum insulation practicable—as is necessary, for instance, with thermal storage cylinders—a combination of different materials can be used. These may consist of a plastic composition, laminated asbestos paper and a casing of planished steel.

The application of insulation in general, demands a suitable protective finish to prevent both damage to the covering and the absorption of moisture, which reduces its efficiency. Any additional cost entailed in the purchase of insulating material which may be due to the better protection afforded is, therefore, usually well justified.

DISTRICT HEATING

1. General Considerations. It will be appreciated that owing to the extensive nature of district heating only information of a general character can be given within the confines of a book of this description. Despite the enforced brevity in the particulars that follow, however, the reasons for the use of such a system should become apparent, particularly its general effect upon the services to be provided within a building.

The supply of heat and hot water from a central generating station to buildings in a district of a city, or to dwellings of a housing estate or garden suburb, on a communal basis or otherwise, is a method of heat distribution and utilization that has proved successful in many parts of the world. This is evidenced by the benefits derived from its use by both the consumer and the community as a whole, in addition to the producer, owners of building property and municipalities.

Town heating systems were first introduced for the purpose of distributing large quantities of heat in the form of steam produced at central generating stations. Subsequent developments in the distribution of heat, together with the progress made in fuel technology, have shown that similar advantages are to be gained by a system of district heating working in conjunction with high pressure hot water when designed to function on an economical basis. Low pressure hot water may also be used when steam is not required for process work and other purposes.

From the economic point of view, central power stations should be regarded primarily as heat generators, and any electrical energy produced as a by-product, since this is represented by only a small proportion of the heat value of the fuel consumed. This realization has caused many investigations to be made in regard to combining electrical generation with district heating in this country in order to conserve a proportion of the large amount of heat otherwise wasted (see Fig. 61). The practicability of using either a combined (thermal-electric) or a straight system depends mainly upon the density of heat demand and the character of the district concerned.

In view of the advantages to be gained from the use of district

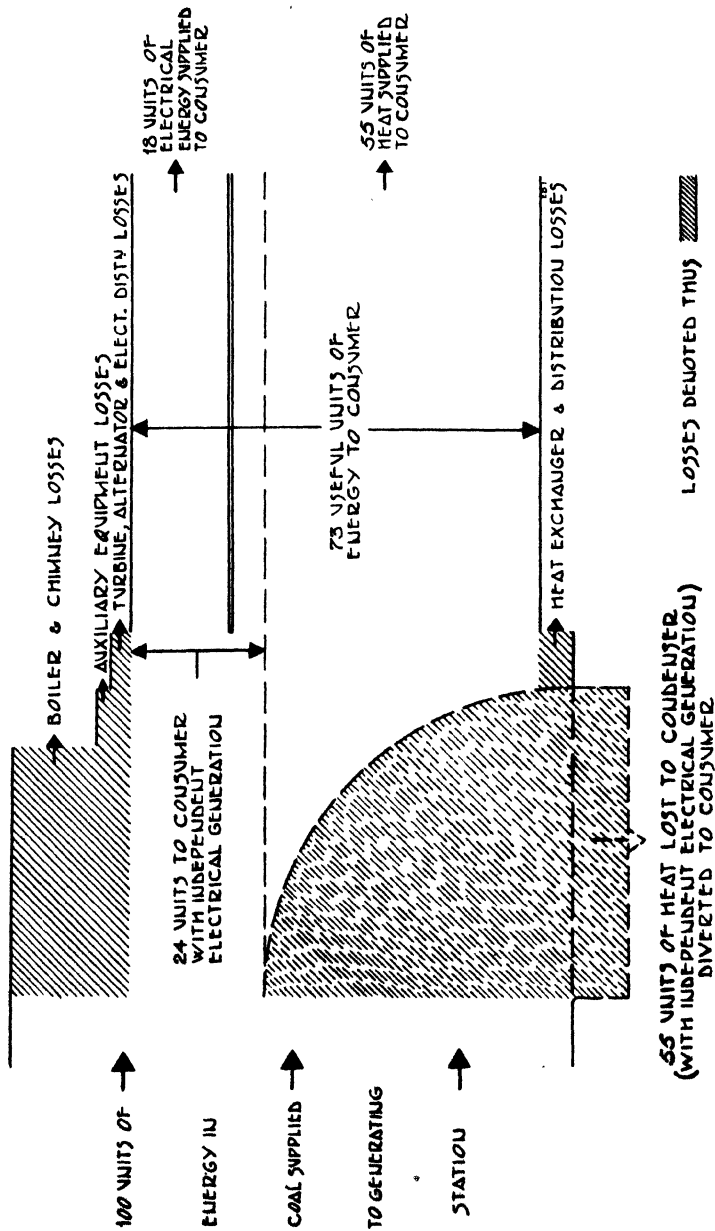

FIG. 61. COMBINED SUPPLY OF ELECTRICITY AND HEAT

Diagram showing approximate relative outputs of electricity and low grade heat for every 100 units of energy intake at generating station. The resultant economy of combined supply is apparent by the quantity of waste heat that can be diverted to the consumer. The total energy at the consumer's premises provided by modern stations is about three times that from a condensing plant.

heating, it is difficult to find a satisfactory reason for the comparatively small use of such a system in this country. Technically, it has been proved to function successfully, and to provide the modern service required. Financially, the working of the system has secured a nominal return on the capital investment for buildings and plant. Climatically, the severity, variability and extensiveness of the winter season in this country justifies the supply of heat "on tap" throughout the greater part of the year for space heating and the whole year for hot water supply. It is in regard to climate, however, that criticism is sometimes raised on the grounds that the annual heat requirements in this country are not sufficiently stable or great enough to provide a paying load.

It is argued that the less severe climatic conditions as compared with those of the European and American continents (where many district heating systems are in existence) do not justify its use in Great Britain. It can be shown, however, that owing to the smaller capital expenditure necessitated for boiler and generating plant to meet the lower maximum heat demand, the running costs of the station plant would be comparatively less. On this account and because the duration of the heating season here is comparatively long, giving a good total annual heat demand, the use of district heating in this country is particularly desirable.

These conditions also favour the use of basic district heating, which further reduces the maximum demand upon an installation. Basic heating, which may be regarded as a temporary compromise to full district heating provides "background" warmth enabling a building to be maintained at a comfortable temperature during average winter weather conditions. When these become severe the "background" warmth is "topped up" by the use of independent local appliances to compensate for the lower external temperature. By this means the owner or occupant of a building is left free to choose between the use of electric, gas or solid fuel appliances for the purpose of supplementing the heating of the basic system after this has been installed.

In view of the circumstances favouring district heating it is possible that vested interests, lack of general co-operation between public and private bodies, or apathy on the part of the public towards improved conditions, are responsible for its restricted use. Whatever the reason may be it is evident that the system will be more widely used in the future only after a fuller realization is manifested of its implications.

In addition to the advantages to be gained by a constant supply

of heat and hot water at all times during the year, the fact that an unrestricted quantity is available for dwelling-houses at a reasonable cost and without entailing effort on the part of the householder, tends to abolish the partial warming of houses with its detrimental effect on general health, by enabling warmth to be provided in every room without engendering a feeling of extravagance on the part of the householder.

When heat is supplied by means of hot water in the larger residential hotel and other classes of buildings, where additional appliances are usually installed for added convenience, the supplementary supply of steam by district heating facilitates cooking, enabling steam-heated hot closets and plates, boiling kettles, and steamers to be used, and also provides increased cleanliness by supplying the needs of certain laundering appliances and fumigating apparatus. Steam pressing of clothes may similarly be undertaken.

The system is conducive to smoke abatement in reducing the pollution¹ of the atmosphere by minimizing the individual consumption of fuel in independent appliances. Its use also conserves space in buildings by obviating the installation of boiler plant and reducing the accommodation required for fuel storage. Moreover the labour necessary for attention to central heating and hot water supply boiler plant is eliminated, as is that for delivery of fuel and ash removal with the consequent dirt and dust.

The financial practicability of converting existing industrial, commercial or residential localities to a system of district heating depends primarily upon the density of the heating loads to be connected and their location in relation to the source of heat supply. These two factors should be sufficient to repay the cost of converting existing property, since the expense to be incurred must include the work involved in disconnecting and removing existing boiler plant, adapting the systems for supply, and laying distributing mains in thoroughfares that may be already congested with other services.

The density of the load, which is determined by the quantity of heat to be supplied within a specific ground area, and its relation to the distance it has to travel from the generating station may be expressed as an economic ratio, and upon this largely depends the financial success of conversion. It will be seen, therefore, that a district containing multi-storied buildings in close proximity to each other requires a concentrated load of heat to be supplied over a

¹ See Appendix E.

relatively confined area, and if situated within close distance of the source of heat supply, it will be particularly adaptable for conversion.

The incorporation of a system of district heating in the planning of a locality of new buildings with an appropriate heat demand naturally facilitates the distribution of heat inasmuch as the heat generating station can be centralized, the distributing mains laid with comparative ease, and heating apparatus installed in each building of uniform pattern to facilitate connection to distributing mains. This combination of circumstances not only reduces the initial cost of the installation, but enables the heat to be produced and distributed economically without reliance upon sources of waste supply.

There are many district heating systems in use in different parts of the world. The number in each country varies according to the climatic conditions, the method of town planning carried out, and type of building erected. In this country little development has taken place with systems of any size, but in Scotland two small-scale installations exist where the service is applied to housing estates. Investigations into the character of the service provided by the systems reveal that the cost to the consumer of centrally warming the entire house and providing a liberal supply of hot water is equivalent to that which would be incurred by the purchase of sufficient fuel to heat one room and to provide for cooking and a limited supply of hot water where local appliances are used.

To-day when it is more necessary than ever to exploit the country's natural resources to the best advantage to secure national economy, it would appear to be essential to increase the use of heat that is supplied to the consumer from large central boiler plants, since this is one of the most economical methods of utilizing solid fuel for space warming purposes and, therefore, of conserving fuel supplies.

Mass production and distribution of heat for the benefit of the general community may be regarded as a logical solution of some of the problems that now confront the coal industry. It is certainly a means of improving the standard of health and hygiene for the individual.

2. Distribution Systems. A close study of the subject of district heating reveals that the successful distribution of large quantities of heat, whether derived from sources of waste supply or otherwise, and supplied on a zonal group or other basis, requires the use of a system of transmission that will ensure the maximum of heat conservation under all conditions of operation. This is a factor

equal in importance to the economical production of the heat to be distributed. Not only must the system used ensure that the heat losses in transmission from the station to the buildings are reduced to a minimum by effective methods of insulation, but also by diminution, whenever practicable, in the number of circulating mains used.

A factor of no less importance than the method used for the conveyance of heat is its economical utilization. The system adopted should, therefore, be capable of closely controlling the temperature of the heating medium circulated throughout the buildings so that it may be varied in strict conformity with changes in climatic conditions. This need is sometimes wrongly disregarded in an endeavour to minimize the initial cost of the installation.

Determinatives of the use of an appropriate distributing system in any circumstances are the character of the service to be provided, the levels of the district to be served, and the class and size of buildings to be supplied, together with the capital expenditure to be incurred for plant, particulars of each of which must first be known. The character of the service required will affect the type of distributing system used according to the class of apparatus to be connected. If, for instance, central warming and hot water supply only is to be provided, this may be obtained by separate flow and return mains for the supply of each service. Alternatively, if the configuration of the site permits and the buildings to be connected are of sufficient capacity, a steam and condense main may be used to supply calorifiers situated in each building and provided with automatic temperature control.

Where steam is required in each building for domestic use and process work, in addition to warming and hot water supply services, a steam system similar to that described for the purpose above may be used, but here again the levels of the district and other circumstances may be such as to make the use of hot water preferable.

The use of water at high temperature to supply all services by means of a combined circulating system of distributing mains is an alternative method that is found to facilitate the conveyance and utilization of heat in certain circumstances. This system which may employ the use of two flow mains and a single return main common to both flow mains, enables water to be supplied to space heating appliances at variable temperature through one main without affecting the service to be provided by the second flow main. It is used to supply calorifiers for domestic hot water or

for the production of steam in a building for direct supply to steam appliances, when it may also be used for the supply of hot water.

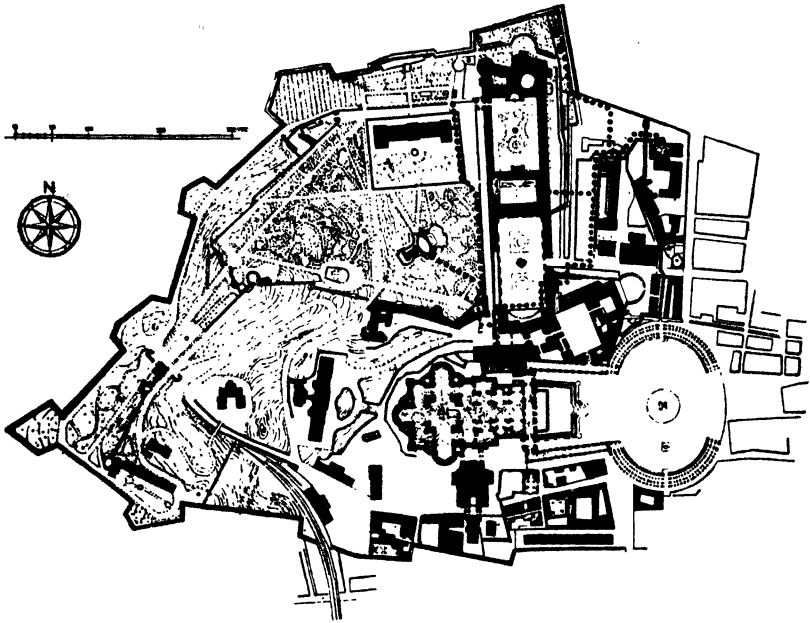

FIG. 62. DISTRICT HEATING OF VATICAN CITY

Above: Diagrammatic representation. The dotted line indicates some of the distribution mains from the central generating station in the N.E. of the city.

Below: Aerial view.

When central warming and hot water supply only are required this may be met by high temperature water through a single flow and return main without impairing the efficiency of either service and at

the same time maintaining the rigid control of temperature necessary to contend with climatic variations.

In consequence of distribution variations, the particular conditions encountered in a locality must determine the system used to convey the heat to the various buildings at the temperature and in the form required. The expenditure involved for the purchase of plant will depend on the method used and must be commensurate with the advantages to be gained by adopting any one particular system. Although it is preferable that the system should be low in operating costs rather than in its initial cost, a limitation must be imposed upon the extent of the apparatus considered necessary to provide the absolute maximum of distributing efficiency if the capital expenditure is not to become prohibitive.

The ratio of the quantity of heat transmitted to that lost in transmission—which must be kept within certain prescribed limits—in addition to being affected by the length of travel of the heating medium and the number of mains used, can be lowered, as already mentioned, by the provision made to restrict the heat loss from the mains themselves. The determinant in this connection is not only the maximum insulation of mains, but the provision of means to retain the insulation efficiency. This entails the construction of pipe trenches or special conduits in a manner that ensures the exclusion of all surface and subterranean water to keep the insulation dry so that its thermal non-conducting properties may not be impaired. The type of conduit used for this purpose should preferably provide easy access at points needing periodical inspection and maintenance. An illustration of a district heating system is shown in Fig. 62.

District heating, in fulfilling the needs of modern times, must eventually provide a means of heat supply in the same way as that of other services providing gas, water, and electricity.

HOT WATER SUPPLY APPARATUS

1. General Requirements. There are few buildings erected to-day that do not require the provision of means for a constant supply of hot water to make their mechanical equipment complete. The information contained in this chapter concerns those methods dependent upon the use of centralized boiler plant. Particulars of localized hot water supply appliances are given in Chapter XIV.

The type and arrangement of the apparatus for domestic, commercial or industrial purposes will vary according to the conditions of its operation and the service to be provided. The requirements, for instance, of a household bath or kitchen sink, differ from those of a laundry or swimming bath, and this must necessarily affect both the type of system and apparatus to be installed.

To ensure that the apparatus will be satisfactory it must be able to provide an ample supply of water at all times at the requisite temperature (100 to 200 deg. F.). This necessitates not only an adequate boiler output and sufficient hot water storage accommodation, but means for the hot water to be in circulation at or near the draw-off point and capable of being withdrawn at a normal rate of flow. At the same time the lay-out of the apparatus should be reasonably compact to avoid excessive thermal loss from the circuits such as may occur in the residential class of building in particular.

The careful design of circuits will ensure the provision of adequate supplies at the required temperature, provided there is sufficient reserve of hot water to meet the maximum demands and it is upon the assessment made of the quantity of storage water for this purpose that the successful functioning of an installation largely depends. Since it is not possible accurately to deduce from formula the quantity of water storage required—such as can be done to determine the capacity of a space warming installation—recourse must be had to empirical methods.

Owing to the intermittent nature of the demand for hot water, both in time and quantity, it is necessary to assess the maximum requirements to satisfy peak demands according to the number and type of fittings to be served and the probable extent of use as indicated

by the class of building concerned. Alternatively, an allowance may be made per person on an occupancy basis for different buildings. It is considered for example, that a reasonable minimum allowance of hot water for two adults and two children occupying a small house would be 250 gallons a week at a temperature of 140 deg. F. A

TABLE XI
HOT WATER SUPPLY AND STORAGE

Hot-water consumption, gallons per person per day of 24 hours on day of heaviest demand during week.

Building	Gal. per person per day	Storage gal. per person
<i>Flats—</i>		
Tenement	15	5
Residential over £120 p.a.	30	7
<i>Private Houses—</i>		
up to 6 persons	25	10
Hotels, average	25	8
first-class	30	10
<i>Hospitals—</i>		
Mental Hospitals, Patients and Staff	20	5
Infectious Hospitals	50	10
General Hospitals	30	6
<i>Schools and Colleges—</i>		
Day	3	1
Boarding	25	5
Offices	3	1
Factories	3	1

(I.H.V.E. Guide for members' use only)

hot water storage tank of 35 gallons represents a minimum capacity. Further details of allowances are given in Table XI.

In order, therefore, to ensure sufficient reserve in the capacity of the storage cylinders to be installed (and power of the boilers to serve them), it is as well to ascertain that a generous allowance has been made to meet every contingency, since the cost of initial water storage space is small compared to any additional cylinder capacity that may have to be subsequently installed.

The heating capacity of the boiler plant in relation to the storage capacity of cylinders or calorifiers will also depend to some extent upon the nature of the demands likely to be made upon the system and the extent of circulating mains, but this ratio of boiler heat output to storage water intake can, in most circumstances, be fixed at approximately 1 to 2. The storage water heat intake can be made more effective with the intermittent use of direct systems if provision

is made for quick heating. By arranging a suitably positioned connection on the storage vessel a larger volume of water can be made available at the required temperature within a shorter time after applying heat.

Intermittence in the demands for hot water also leads to the dual use of fuels as a means of facilitating its supply, especially in residential buildings where a relatively small quantity of hot water is often required at short notice in summer time. Combining the use of two fuels may also prove to be a further convenience in the event of failure of one fuel supply or delivery, or of the boiler itself. Such an arrangement may entail the use of a gas circulator interconnected with the solid fuel-fired boiler circuits, or the provision of an electrical immersion heater in the calorifier or cylinder normally heated by such a boiler.

In addition to the provision of hot water for withdrawal at the various fittings throughout a building, an apparatus may be required to function as a partial heating system. This is so when such appliances as towel rails, radiators or airing coils and pipe drying racks are connected to the circuits, and the apparatus must, therefore, be capable of circulating sufficient water at the required temperature to provide the amount of heat necessary for this purpose.

Hot water for supply to buildings such as laundries may be made available by storage calorifiers or cylinders or by the introduction of steam to water mixing valves, by the introduction of steam direct into water contained in storage tanks, and occasionally by the supply of hot water direct from the boiler to the appliances. Whichever method is employed, there can be no doubt as to the storage or output capacity of the installation required, since this must be sufficient to deal with the known maximum output of the laundering appliances.

The provision of hot water for swimming baths involves certain features quite distinct from those connected with the supply of hot water in general. Apart from the capacity of the bath, its form of construction and conditions of use influence the type and capacity of the apparatus to be installed. Since the greater proportion of heat to be provided is required for the initial rise in temperature of the water, that necessary to compensate for heat losses from the circuit mains, through the sides and bottom of the bath structure, and from the surface of the water itself, becomes a matter of secondary importance. The capacity of the boiler plant and its general arrangement will

consequently depend upon the time permissible to heat up the water during and after filling the bath, which in turn will depend upon the method used for the provision of clean water.

The material used for calorifiers, cylinders, pipes and fittings is normally wrought iron or mild steel with a galvanized finish, but the nature of the water supply will affect the material used, and in districts where it is "soft" it may be necessary to use non-ferrous metal to prevent the deterioration by corrosion that otherwise occurs. This class of material is also to be preferred when greater permanence of the installation is desired.

The state of the water obtained from the various water companies' mains throughout the British Isles differs within wide limits according to its source of supply. For this reason, should there be any uncertainty regarding the physical and chemical properties of the water to be used in a particular district, reference to an analysis should be made to ascertain what they are, or the advice taken of the local supply authority.

2. Alternative Systems. Hot water can be made available and distributed by various methods according to the facilities required for its production and the character of the service to be provided, and each of those available has been introduced to serve some particular need.

The two principle methods employed, together with their variants, are as follows—

1. *Direct Systems.*

- (a) With storage vessels.
- (b) Without storage vessels.

2. *Indirect Calorifier Storage Systems.*

- (a) In conjunction with independent apparatus.
- (b) In conjunction with combined apparatus.

The essential difference between direct and indirect systems is that with the former the same water (or steam condensate) from the boiler or heat generator is withdrawn at the tap, whereas with the latter the water or steam in the boiler recirculates through the calorifier only, for the purpose of transferring heat to an independent supply for withdrawal at the tap. Reference to Fig. 63 will make clear the main differences between the systems.

Direct water systems are most commonly used in dwellings where the apparatus required is of small capacity and in buildings where circumstances do not permit of combination with boilers for central heating apparatus. Direct steam systems operate chiefly for

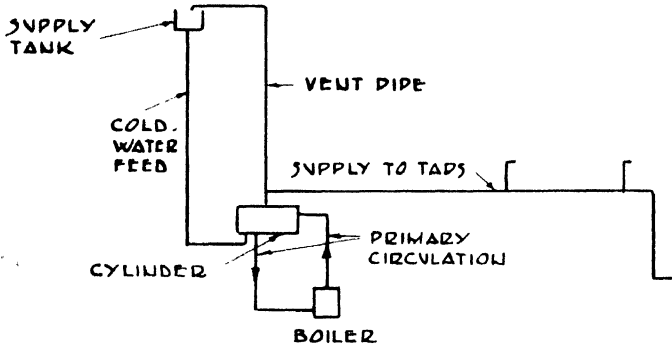

1. DIRECT SYSTEM WITHOUT SECONDARY CIRCULATION

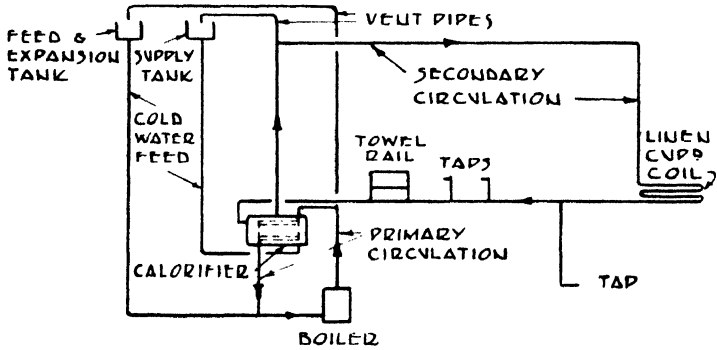

2. INDIRECT SYSTEM WITH SECONDARY CIRCULATION

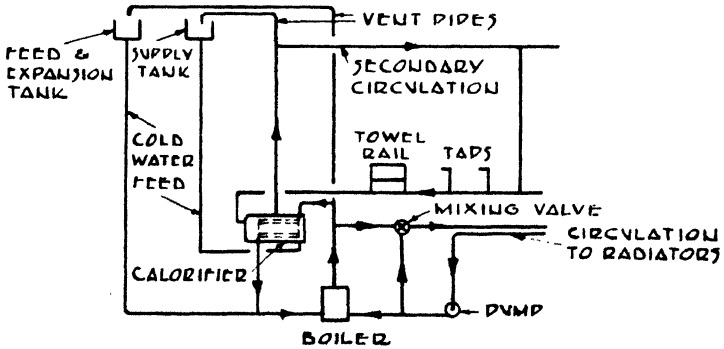

3. COMBINED HEATING AND H.W. SUPPLY SYSTEM. ...

FIG. 63. HOT WATER SUPPLY SYSTEMS

Arrangement of circuits for direct, indirect, and combined systems.

industrial purposes when adequate supplies of steam are available for use with mixing valves and for injection into the water to be heated for storage or immediate use.

Calorifiers, cylinders or tanks for storage of the water heated are customarily used owing to the diversity in both time and quantity of the hot water required. One type of storage calorifier is shown in Fig. 64. A bulk reserve of hot water not only ensures adequacy of supply at all times to contend with wide fluctuations in demand, but enables the capacity of the boilers to be reduced to a minimum, with a reduction in the attention required for them. The rate of fuel combustion is also rendered more normal and constant, resulting in more economical consumption.

Hot water storage vessels may, however, be dispensed with and the water circulated direct from the boiler to the draw-off points. This method may be found advantageous, for instance, in the modernizing of existing plant when there is insufficient space available for the accommodation of storage vessels. With such an arrangement the water capacity of the boiler must be suitable for the purpose, and its heat input controllable within close limits. The use of steam may also obviate storage facilities by its introduction at the point of hot water utilization.

Indirect systems are necessary when it is undesirable or impracticable to intermix the water or steam from the boilers with that supplied to the taps or storage vessels. In the case of an independent apparatus, such as is generally used in residences, for example, an indirect system will give more satisfactory results than the direct method especially if provided by a central heating type of boiler, and when the temporary hardness of the water supply exceeds about 160 p.p.m. and is not treated in any way. This arrangement, which permits the use of more efficient types of boiler, obviates the necessity for periodic descaling of the boiler, the initial thermal efficiency of which is more easily maintained on this account.

Fig. 65 shows a small central heating type boiler which supplies hot water on the indirect system and which also supplies heat for radiators. The installing method adopted for the boiler is of interest.

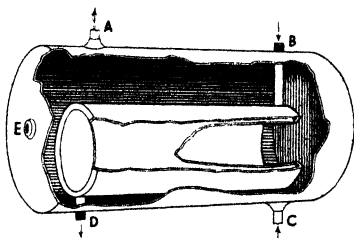

FIG. 64. INDIRECT CYLINDER OR CALORIFIER

A type of calorifier suitable for use with the indirect and combined systems shown in Fig. 63.

A = Secondary flow. C = Cold water feed.
B = Primary flow. D = Primary return.
E = Secondary return.

Reference should also be made to boilers in Section 3 in Chapter VIII.

Indirect systems are used principally with steam and when the hot water supply apparatus is combined with the central warming apparatus so that both systems may be served from a common boiler plant. Such an arrangement is necessary (unless special

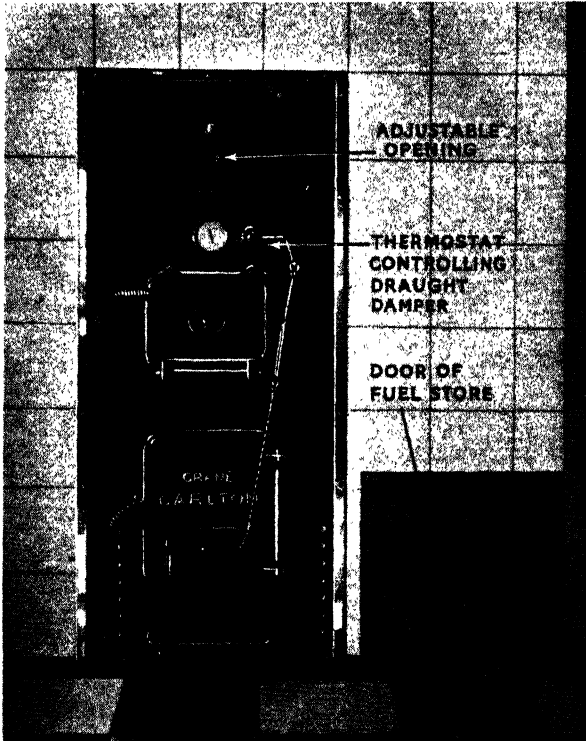

FIG. 65. BOILER OF THE CENTRAL HEATING TYPE INSET FLUSH WITH WALL FACE

The adjustable opening delivers fresh and recirculated air warmed by boiler after entering inlet in external wall and through inlets in lower surround of boiler.

precautions are taken) to avoid circulating fresh water throughout both systems in order to prevent furring or corrosion of the central warming apparatus pipes and discoloration of the water supplied to the sanitary fittings. It also eliminates any adverse effect upon the flow of water in heating systems depending upon a gravity circulation.

Combining of central warming and hot water supply apparatus is designed to reduce the cost of the installation and the attention

required for its operation, but it may prove detrimental to the service to be provided so far as temperature is concerned. With the smaller installation this is probably of little consequence but in larger buildings it can create unsatisfactory conditions unless precautions are taken for their avoidance. Some precautionary measure is obviously necessary, because of the different temperature requirements of each system. When the weather is mild sufficient warmth is provided for the heating apparatus by a low boiler temperature, but the reverse is necessary for the hot water supply apparatus. Consequently either the building is overheated or the temperature of the hot water supply is inadequate unless some form of automatic temperature control is provided.

Other considerations affecting the type of system and arrangement of apparatus relate to such questions as limiting the quantity of hot water to be made available in different sections of a building, for example, in certain classes of flat or tenement building. In these circumstances curtailment of supply, to prevent extravagance or waste, can be effected by adopting a "rationing" system which, by the use of independent remote calorifiers, enables the amount of water consumed individually over a given period to be restricted to a definite quantity.

3. Subsidiary Apparatus. The extent of the ancillary apparatus necessary for the supply of hot water throughout a building will vary according to the incidental services required and the manner in which they are to be provided. The items of apparatus used will, therefore, be dependent upon whether full use is made of the hot water circulated, and the efficiency obtained in the facilities it can be made to provide.

The arrangement of circulating mains and branch circuits to distribute the hot water to appliances and draw-off points is similar to that necessary for central warming installations with the exception that their position, or the extent of thermal insulation used, may have to be varied because the transmission of heat continues throughout the year. The water is either circulated by natural gravitation or by an accelerator according to the circulating pressure required, and to ensure that hot water is available at draw-off points within a few seconds of opening the tap and that an adequate quantity is discharged without undue delay, it is necessary to avoid using long lengths of single branch piping and to size the circuits and branches to pass the required quantity of water. Particulars of tap discharge will be found in Table XII. It is also important that the

TABLE XII
DISCHARGE FROM TAPS

Approximate discharge required from hot or cold water points

Bath (private)	6	gal. per min.
Bath (public)	8	" "
Sink	4	" "
Basin	3	" "
Shower spray	2	" "
Shower 4-in. rose	4	" "
Shower 6-in. rose	9	" "

main cold water feed should be capable of meeting peak demands.

The type of fitting used at the draw-off point may appear to be a matter of little importance, but it may have a considerable effect

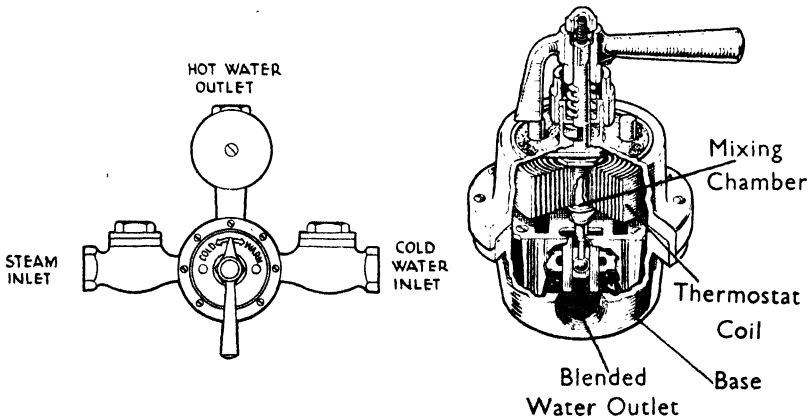

FIG. 66. STEAM AND WATER MIXER

A mixing valve for providing instant hot water from steam and cold water, with thermostatic control.

Left: Arrangement of connections.

Right: Mixer.

(Leonard-Thermostatic)

upon both the quantity of water used and fuel consumed, apart from any question of convenience in use. The supply of water to ranges of baths and showers, for instance, can be produced at the required temperature to avoid scalding and waste by the use of automatic intermixing valves, and the quantity of water discharged from showers may be made dependent upon the type of spraying fitting used. Fig. 66 illustrates one pattern of mixing valve for use with steam. The type of tap used for sanitary fittings in general is also important, since much water (and fuel) can be wasted unless it is designed to function with a positive closing action. Inconvenience

caused by splashing from hand basins situated in the lower floors of high buildings—due to excessive pressure at the tap when opened—can be avoided by the installation of pressure reducing cocks in the branch pipes to fittings.

Heated towel rails, which are now becoming a common fixture in bath and toilet rooms, vary in type and finish according to requirements. When additional warmth is required, radiator sections may be combined with the rails, which, when arranged with double top rails, facilitate drying at the same time. Towel rails, are constructed for floor and wall fixing, and are of various sizes both in regard to overall dimensions and diameter of tubing. The finish may be nickel or chromium plating, or coloured enamel. A typical type of rail is shown in Fig. 67.

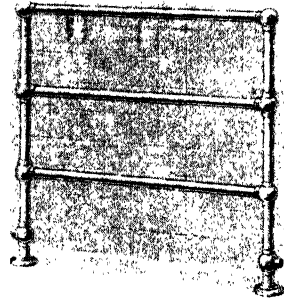

FIG. 67. TOWEL RAIL
(Ideal)

Airing coils for use in linen cupboards may be formed as part of the circulating piping or connected to it as an independent appliance, according to the arrangement of the system's circuits. Drying rails may be installed in the same way, and may be constructed to form clothing hangers and footwear racks, if desired. Alternatively, drying may be carried out by means of clothing horses positioned over hot water coils.

The use of radiators served by the hot water supply system is normally limited to rooms that require to be warmed throughout the year, such as operating theatres in hospitals, although a single room or hall in residences may be heated in this way. Radiators that are installed under these conditions may need to be constructed of copper or treated internally with an anti-corrosive finish to prevent discoloration of the water.

Radiators for warming an entire building must, in addition to the anti-corrosive precautions, be provided with automatic temperature control, and those parts of the apparatus in contact with water supplied to draw-off points must also be galvanized or made of non-ferrous materials. At the same time, calorifiers with ample reserve capacity to avoid an excessive fall in the temperature of water circulated to the radiators must be embodied, and the circuits themselves must be carefully proportioned in size on a priority basis.

LOCAL HEATING APPLIANCES

1. Alternative Methods. The term "local appliances" refers to those that generate their own heat by the consumption of electricity, gas, oil or solid fuel within the appliance itself and are therefore independent of the transmission of hot water, steam or warm air from a central source of supply. They are used principally in the smaller type of building.

This chapter is devoted to a brief description of the principal local types of appliances available, together with some information regarding their different uses. The particulars given also serve as a means of comparing the particular characteristics of these types of appliances with those forming part of a centralized installation so that their respective merits for different circumstances may be appreciated.

The reason for the use of localized appliances in preference to the centralized type is usually to be found in the former's lower purchase and installation cost, although some types are also more convenient in use, depending on the class of fuel consumed. The advantages of reduced cost in the supply and fixing of these appliances, however, may be more than off-set by a reduction in thermal efficiency, with a consequent increase in the cost of procuring heat, thus making them a comparatively extravagant means of providing warmth. The thermal efficiency of an appliance will often be related to its capital cost, and a resultant saving in fuel may justify extra capital outlay.

Where both convenience of installation and use are the chief attributes of an appliance it is generally found to be the most expensive method of providing heat. Compromise is therefore sometimes desirable to ensure that the cost of warming an apartment or an entire building does not become exorbitant. For this reason an appliance that can utilize an alternative class of fuel either independently or simultaneously will often prove to be more economical.

The period of use of an appliance is an important factor both in regard to the method of procuring the heat and its form of transmission. Thus when the heat requirements are of an intermittent nature, as in the occasional warming of a room, an appliance that

is capable of providing immediate warmth will be more effective than one that requires some time before its functioning is fully beneficial.

Appliances that can give a high proportion of local heating, for example, those that supply a beam of radiation from high temperature elements, will be found effective in providing "personal" warming since a degree of comfort can be obtained when a person is near the appliance without warming the entire room. For the latter purpose it is necessary in the selection of an appliance for intermittent heating to ensure that its heat output is such that the pre-heating period required is not excessive. This period can be further reduced by using materials of low thermal capacity for inner surface wall linings.

Other considerations that influence the choice of an appliance are cleanliness, controllability, appearance, compactness, safety and portability, and the relative importance of these features can only be assessed in given circumstances.

The design of the various appliances to be described is based upon fundamental principles for the transmission of heat similar to those governing the centralized type, and hence the form taken by an appliance is dependent upon whether the heat is emitted mainly by convection or radiation and the temperature of the element necessary for their provision.

The need for an appliance that provides hot water and facilities for cooking in addition to a supply of heat for space warming has produced a number of combination appliances. On this account it is necessary to consider in connection with small dwellings the desirability of installing a multi-purpose appliance in order to obtain these three services simultaneously. At the same time such an appliance may be utilized as part of a compact pre-assembled unit embodying complete hot and cold water systems and other services, which may now be obtained direct from the factory.

The various types of heating appliances available may be summarized under the following general headings—

Solid Fuel—

Fireplaces: Open and closeable types with well or sunken hearth or bar grates.

Combination Appliances: As above.

Stoves: Open, closeable and closed types.

Convactor Heaters: Unit heater types.

Gas—

- Fires: Radiant and radiant-convector types (convector fire).
- Radiant Heaters: High and low temperature types.
- Radiators: Variable radiation component types.
- Convector Heaters: Background and unit heater types.

Electricity -

- Fires: Reflector and firebar types.
- Radiant Panels: High, medium and low temperature types.
- Radiators: Vapour, hot water and oil types.
- Convector Heaters: Unit heater, cabinet and tubular types.

Oil—

- Stoves and Radiators.

Oil burning appliances for space warming purposes are familiar in the types mentioned above, but those using other fuels are further described in some detail in the following pages, and particulars are also given of those designed for the supply of hot water.

Developments in research resulting in improved design together with advancement in methods of construction have produced, in general, appliances that now function with increased efficiency, particularly in the case of those designed to burn smokeless solid fuels. The progress made with those burning coal in the open fireplace has necessarily been slow owing to certain inherent difficulties, and the thermal efficiency of the majority of these appliances remains much as it was at the end of the last century.

Despite the inefficiency of the open fireplace of general design there remains a strong prejudice in favour of its continued use in this country owing to its attraction as a centre point of home life. For this reason there is little sign of its being entirely discarded in favour of more modern methods of producing warmth, and its survival in modified form must, therefore, be contemplated for some time to come.

The current expense incurred with the use of a particular type of appliance, when considered in relation to the volume of space to be warmed and class of fuel used, is an important factor affecting the ultimate choice of a method of heating as will be seen by reference to Table XIII. This necessitates a careful investigation of the prices charged for the supply of different classes of fuel in a particular locality, and of the thermal efficiency of appliances, before a final decision can be made.¹

¹ See Appendix H.

TABLE XIII
RELATIVE FUEL COSTS

Fuel and thermal value ¹	Type of Appliance	Appliance efficiency ¹ per cent	Optimum cost ² in pence per therm with fuel at prices ³ as under			
Coal at 12,000 B.Th.U.'s per lb.	Open fireplace	20-30	70/- 10-4	75/- 11-1	80/- 11-8	per ton
	Closeable fire—closed	55-60	5-2	5-6	5-9	
	Closeable fire—open	45-55	5-7	6-1	6-5	
Coke at 12,000 B.Th.U.'s per lb.	Open grate	25-35	75/- 9-6	80/- 10-2	85/- 10-9	per ton
	Closeable fire—closed	60-70	4-8	5-1	5-4	
	Closeable fire—open	50-60	5-6	6-0	6-3	
	Closed stove	60-70	4-8	5-1	5-4	
Anthracite at 14,000 B.Th.U.'s per lb.	Closed stove	60-70	90/- 4-9	100/- 5-5	110/- 6-0	per ton
Paraffin Oil at 20,000 B.Th.U.'s per lb.	Stove	95	1/2 9-2	1/4 10-5	1/6 11-8	per gal.
Gas at 100,000 B.Th.U.'s per therm.	Fire	40-50	9d. 18-0	1/- 24-0	1/3 30-0	per therm
	Fire convactor	55-65	13-8	18-5	23-0	
	Flueless heater	90	10-0	13-3	16-6	
Electricity at 3412 B.Th.U.'s per unit	Fires, radiators, and convectors	100	1d. 14-7	1d. 22-0	1d. 29-4	per unit

¹ The actual efficiency obtained under working conditions will depend upon the make of appliance selected, its intermittent or continuous use, and care taken in its operation.

² Costs will be subject to any increase incurred for labour.

³ Figures to be adjusted accordingly.

When the district cost of the more expensive fuels is found to be below the average, their use may be as economical as that of cheaper fuels, when all other factors, including intermittent heating have been considered.

The installation of local heating appliances calls for a judicious selection from the many types available if full advantage is to be taken of the various benefits to be derived.

From the information that follows it will be seen that several alternative combinations can be made. These will depend upon whether they are required for such buildings as houses (urban and rural) or for schools, offices, shops, and cafés. The planning of the building and the purpose for which it is used must, therefore, be the criterion in determining which of the different appliances available is most suitable for the particular service to be provided.

Consideration must also be given to the use of basic heating. Providing continuous "background" warmth sufficient to keep a

building off the chill and free from dampness ensures more economical heating and a higher standard of comfort, and will affect the type of local appliance to be installed to provide the "topping up" warmth.

2. Solid Fuel Appliances. An appliance that is able to burn a fuel providing a cheerful effect as well as heat, as with the open hearth, is still considered to be an essential feature in the equipment of nearly every class of modern residential building. This combination of traditional heating methods with modernity in building technique, although giving character to the finish of an apartment and enhancing its appearance in winter time, is retrogressive from the point of view of procuring warmth efficiently.

The general use of a conventional open type of coal fireplace must be deprecated not only because of its inefficiency as a heating appliance and in the interests of smoke abatement, but owing to the work entailed and dirt created in handling the fuel, laying fires and clearing away the ashes. Because of these disadvantages other types of appliance have been introduced which burn a full range of solid fuels and are cleaner in use and more economical in labour and fuel. Appliances recently designed to consume smokeless fuels are now able to supply nearly double the amount of heat for warming and hot water with the same expenditure of fuel.

The various classes are as follows—

OPEN FIREPLACES. The principal features of these appliances are familiar and require little explanation except perhaps in regard to the main differences in construction which separate them into two distinct types.

One modern design of non-closeable fireplace embodies a plain well of refractory material upon which the fuel is burnt and is usually without any metal fittings. With this form of construction it is comparatively easy to keep clean and coal can be burnt with less inconvenience.

The alternative to a well or sunken fireplace, which preceded it, consists of an independent metal stool fire fitting into the space normally occupied by the well and provided with a fret with sliding air register. If desired a canopy and hobs may be provided and also front bars. The entire bar grate is well known as the dog or basket grate of which numerous designs are available.

Both types, although often pleasing in appearance and in some cases comparatively easy to use and keep clean, burn fuel with almost equal inefficiency and the choice of one or the other is usually decided on æsthetic rather than scientific grounds.

Owing to the absence of any positive means of controlling the combustion of fuel in an open grate of the types described, and the lack of any facilities to obtain convected heat the thermal efficiency of these appliances is poor, about four-fifths of the heat in the fuel being lost up the chimney. At the same time it should be mentioned

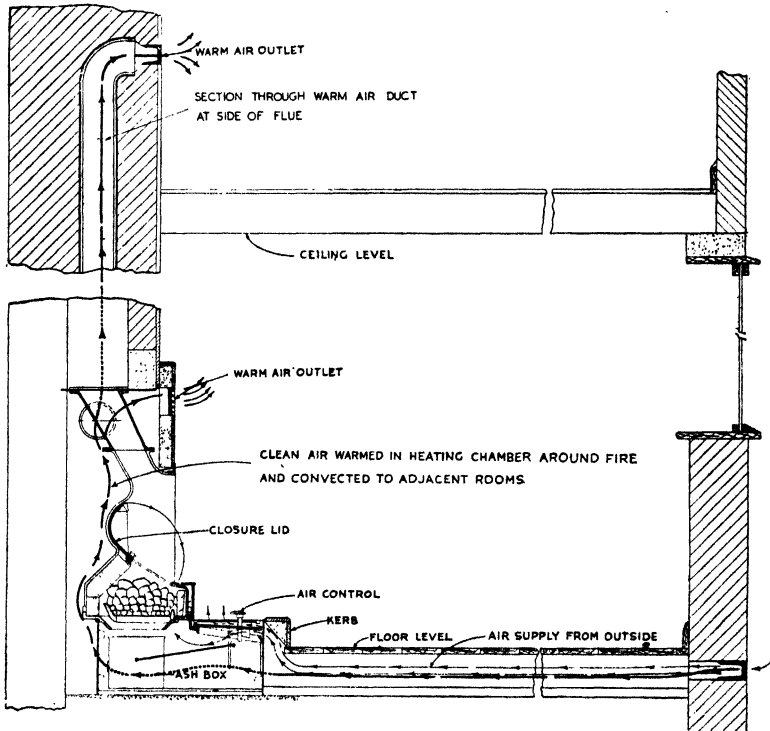

FIG. 68. CLOSEABLE FIREPLACE

Sectional diagram of space heater installed in chimney opening, showing details of air supply to the unit and provision for upper room heating.

in fairness to them that the loss of heat incurred is mitigated to some extent in that they provide a means of ventilation which is not always obtained with flueless types of heaters.

Two recent improvements in the design of the open fire appliance are those which have been made to increase thermal efficiency and render it continuous burning. These appliances, which, in principle, are an adaptation of the slow combustion stove, make greater use of convected heat by utilizing the rear of the grate for warming the air in the room or one adjoining and so increase the amount of useful heat procured from the fuel.

A lid fitting into a recess at the back of the fire can be closed down to enable it to burn for about twelve hours without refuelling. An arrangement of this type of appliance is shown in Fig. 68.

Considerable improvement is also obtained by the use of a grate which has recently been developed to take advantage of the benefits of burning a smokeless fuel such as coke. This fuel is not only cleaner to handle but is also free burning, giving more uniform radiant heat

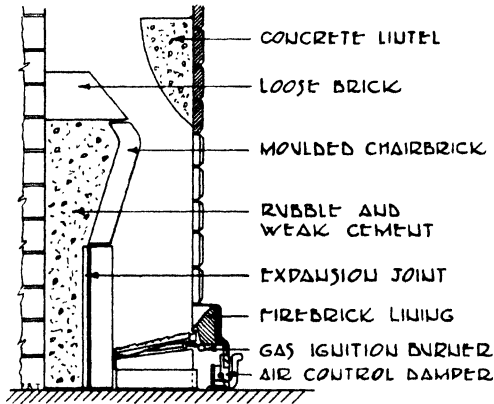

FIG. 69. THE FULHAM GRATE

Section of an open type fire suitable for burning high temperature gas coke, other smokeless fuels, and household coal.

(Eagle Range & Grate Co., Ltd.)

with less attention than is required with coal. The fire is lighted by gas burners embodied in the appliance, and is an added convenience in the use of unreactive fuels. Fig. 69 illustrates one type of this grate.

Many of the type of appliances may embody a boiler and can then be used to supply hot water for domestic purposes for washing or heating radiators.

Open fireplaces in general cannot be regarded as an efficient means of producing heat, a failing the more apparent in those whose sale relies upon the peculiarly lurid tile surround and other embellishments rather than upon a sound scientific design of the grate itself. Appliances of this description appear to confirm the belief that there is always someone ready to produce an article inferior to any in existence for the purpose of personal gain. Further particulars of open fires may be obtained from the British Standards Institution.

COMBINATION APPLIANCES. An appliance that provides facilities for a supply of hot water and for cooking in addition to space

warming is often found in the residential class of building. Combining the three services in one appliance is an effective means of reducing the purchase cost of equipment and economizes in the space required for its accommodation in addition to the labour required for its working. These are factors sometimes considered to be of sufficient importance in the smaller dwelling to offset the disadvantages of the appliance.

The disadvantages likely to be experienced are mainly apparent when the three services are required in full simultaneously. At such times some triple-purpose appliances become less responsive to exacting demands and tends to be extravagant in fuel consumption. The thermal efficiency of such an appliance is not always as high as that of those designed to provide one only of the three services, since combining the three together sometimes means a compromise in the principles affecting economic heat utilization. When used intelligently, however, this appliance can be made to fulfil all normal requirements.

The simplest form of triple-purpose appliance consists of a grate of the well or bar pattern with back boiler and oven above or at the side. Variations in design occur according to the particular facilities required and include the provision of a closeable fire for continuous burning and summer use, and appliances designed upon the back-to-back principle to enable the fireplace for space heating to be in a room adjacent to that in which the cooking facilities are to be provided. This two-way appliance may be embodied in an all-purpose service unit pre-assembled for installation where compactness is required together with dependable service. The unit may also comprise the flue, hot and cold water systems, electrical installation and sanitation. Fig. 70 shows one type of pre-assembled unit.

STOVES. In order to burn fuel under cleaner conditions and for long periods without frequent attention stoves of various descriptions have been introduced, some of which also produce heat with considerably less waste than the open fireplace. These appliances, which are primarily convector heaters, in affording means of controlling the rate of combustion can be made to provide regulation of heat output within reasonably close limits.

The best example of this class of appliance is the slow combustion type of closed stove which, when designed solely for the purpose of consuming a smokeless fuel, functions with a thermal efficiency superior to all other local solid fuel appliances. Such stoves should not be confused with those that merely act as a receptacle for burning

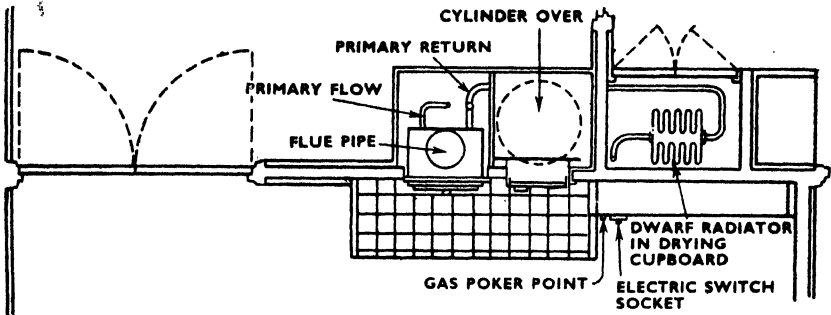

SECTIONAL PLAN THROUGH HEAT SERVICE UNIT, TYPE 1E HOUSE

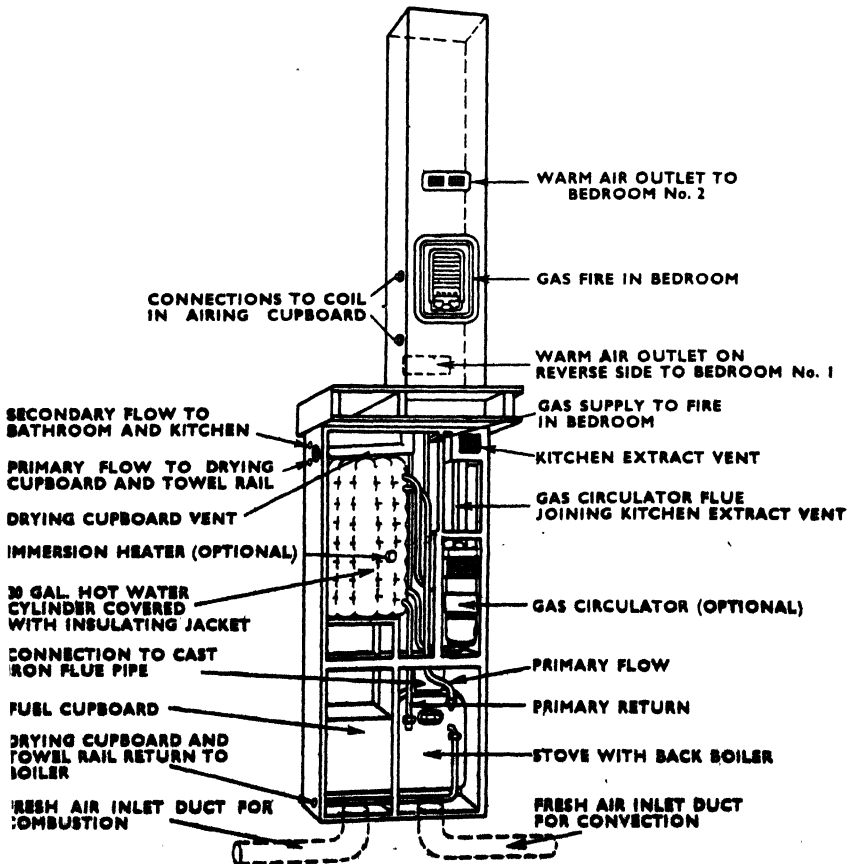

FIG. 70. VIEW OF COMPLETE HEAT SERVICE UNIT WITH PANELLING OF GROUND FLOOR SECTIONS REMOVED

(By courtesy of the Ministry of Works)

various fuels and consist principally of a container lined with refractory material.

The necessity of using a slow combustion stove with a closed front restricted its use until modifications were made so that it could also function as an open fire. In this form it has gained popularity but lost thermal efficiency, making it evident that the latter is considered of secondary importance to appearance.

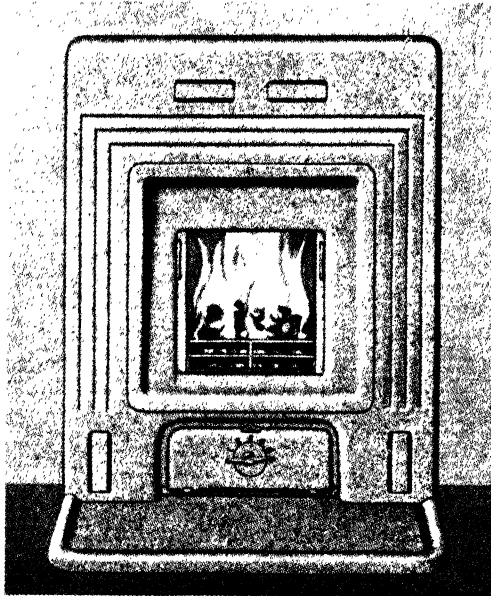

FIG. 71. CLOSEABLE STOVE (ESSE-Q-M TYPE)

A stove of the inset type, with louvres in surround for convection heating.

There is now a wide variety of stoves. Some may be used with an open or closed front whilst others are designed for use either as a permanently open or closed appliance. They may also be used for the dual purpose of supplying hot water or for warming a second room either by hot water radiators or warm air, and are designed to burn coal, coke or anthracite. A closeable type of stove is illustrated in Fig. 71

The use of stoves is particularly suitable where a continuous supply of heat is required with a minimum of attention for refuelling and the clearing away of ashes. They also provide the means of reducing draughts when used as a closed appliance.

UNIT HEATERS. These appliances, working on somewhat similar principles to those described elsewhere for use with steam and hot water, may function independently by producing their own supply of heat. This is effected by burning solid fuel within the appliance so that the hot gases of combustion may be conveyed through the tubes utilized to heat the air in the space to be warmed. They are intended for use principally in the industrial class of building where no facilities are available for the supply of steam or hot water.

All of the appliances described, with the exception of certain stoves consuming graded anthracite, the coke grate and open coal grate are able to burn coal, coke and anthracite, or a mixture. They will also burn the various proprietary fuels produced by a process of bonding and compression or low temperature carbonization, some of which, according to the advertisements, appear to possess mysterious calorific powers.

3. Gas Appliances. An independent or local appliance that uses gas as a means of producing heat, by consuming a fuel that is both clean and easy to control in combustion, enables warmth to be provided in a building readily and with little inconvenience. Not only is it unnecessary to provide space for fuel storage but a flue is not always essential, a feature which also renders the appliance portable in use if desired.

The use of flueless gas heaters, however, is often restricted owing to their failure to provide the same amount of ventilation as those which discharge the fumes externally. To this failing must be attributed the odour that is sometimes present in an atmosphere heated by a flueless appliance, (when insufficient ventilation is provided or due to excessive rates of gas consumption) although hygienically it is not considered to be detrimental in any way since the temperature of the air usually becomes oppressive before any chemical impurity is likely to be harmful. The sulphur contained in gas fumes, however, may have an injurious effect on furnishings, although attempts are being made to reduce this by a higher purification of gas.

Flueless heaters will often be found convenient for providing alternative heating in mild weather or supplementary heating in cold weather.

To secure the increased convenience of gas for space warming, extra cost must normally be incurred as compared with the use of solid fuel. There are, however, exceptions, particularly in regard to intermittent heating, when the cost incurred with gas at low rates

for supply is no greater than that of solid fuel due to the labour entailed with the latter and other disadvantages.

As a producer and transmitter of heat a gas appliance is more efficient than the majority of solid fuel appliances. The gas fire, for example, has a thermal efficiency ranging from 40 to 65 per cent as compared with an average of 25 per cent for an open coal fire, and when used as a flueless heater, a gas appliance should be 90 per cent thermally efficient.

There are many varieties of each type of appliance now available, and on this account the following information must be confined to a brief description of the principal types only.

GAS FIRES. These appliances may be divided into two distinct types which are generally distinguished from each other according to whether they are fitted to a flue as in the independent hearth or panel fire, or provided with a flue outlet designed to discharge into the space below an existing flue, as with the inset fire. Those constructed in the latter way are intended for use in an open hearth, and provide a simple means of utilizing the space available for a solid fuel fire-place.

The more popular form of gas fire provided with a metal surround and flue outlet at the back is well known in appearance but varies in constructional details according to its particular design.

Recent improvements in this appliance have been made to increase both its radiant and convective efficiency and to render it more silent in use, and in some models the position of air inlets is varied by being provided on each side of the radiants. Such modifications make provision for recovering heat from the rear of radiants and in the flue gases by the inclusion of airways for circulation of the air in the room, thereby increasing convection heating to about 25 per cent of the total heat output and giving a thermal efficiency up to about 65 per cent. One type of convector fire is shown in Fig. 72.

The modern gas fire relies upon high temperature radiation for the greater part of its efficiency and hence produces an intensity of heat which by some is considered a disadvantage owing to the unpleasantness caused by exposure of the skin to the high temperature rays for any length of time. The advantage of a gas fire is when it is used to provide speedy temporary local warmth and not as a means of continuous general heating, for which purpose other types of gas appliance are more suitable. This latter need in the form of basic heating may be provided by a centrally heated hot water convector radiant radiator with a gas fire embodied for the purpose

of providing in one appliance both "background" and "topping up" warmth. Such an appliance was seen in Fig. 13.

RADIANT HEATERS. Appliances of this description, which function primarily as radiant panel heaters, usually utilize a high

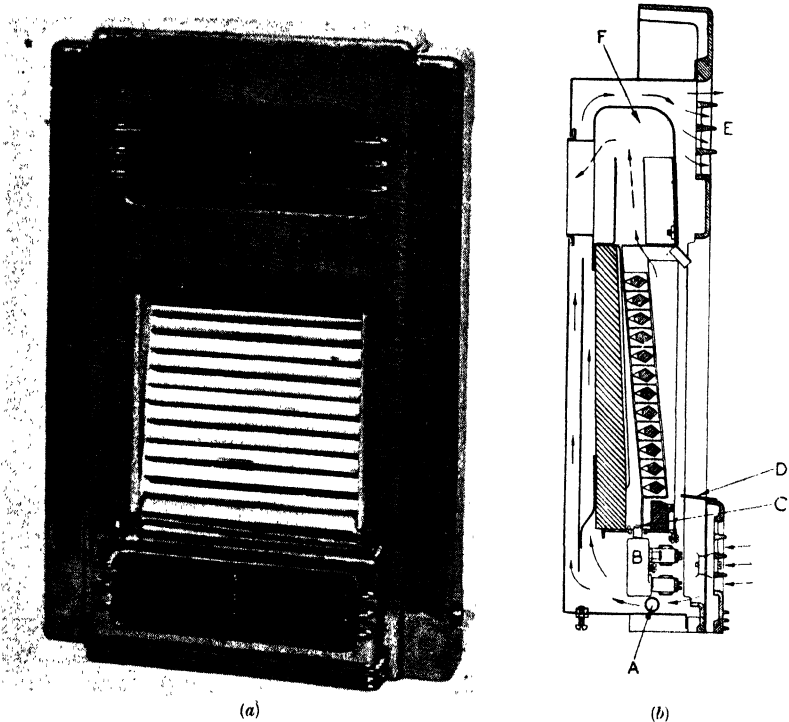

FIG. 72. CONVECTOR GAS FIRE

This type of fire is designed to give warm air from the top outlet louvres, as well as the radiant heat normally obtained from a gas fire. This additional warm air means a substantial increase in total efficiency compared with the conventional gas fire. The fire is particularly suitable for living rooms and dining-rooms.

(b) Shows a diagrammatic section of the fire. Gas enters at connection *A* through control cock, and passes pressure controls to burner *B* and jets *C*. *D* is the reflector. Hot products of combustion pass through the convector box *F* and out of the flue at the back of the fire. Air is drawn through the openings in the fender up the back of the firebrick and over the convector box, the heated air leaving at *E*.

(The Gas Light & Coke Co., Watson House)

temperature surface as a means of radiating heat. Transmitting heat at high intensity in this way directs it where it is most effectual and thereby affords a reduction in overall air temperature of the space warmed and so economizes in gas.

High temperature radiant heaters may have a luminous refractory surface using high pressure gas or utilize a low pressure supply when

the surface is either luminous or non-luminous. The heater is normally fixed in an inclined position overhead, and may be thermostatically controlled if required. If silent operation is necessary low pressure gas should be used, and on this account the high pressure luminous type is most suitable for industrial buildings and the low pressure for such buildings as schools, restaurants and churches. Fig. 73 shows a radiant heater of the high temperature type.

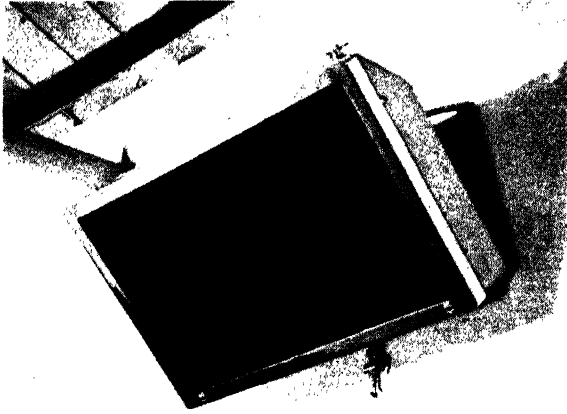

FIG. 73. RADIANT PANEL HEATER

An overhead heater working at a surface temperature of about 650° F. It is also supplied in the overhead bowl and wedge types. Heaters may be controlled collectively or individually by hand or thermostatically.

(Bratt, Colbran, Ltd.)

Low temperature radiant heaters, such as those that emit heat from a metal plate forming the front casing of the appliance, are usually constructed for fixing at a convenient level on a wall. They are intended for use in bathrooms or bedrooms and other small rooms where low temperature radiation can be beneficial and the gas consumption reduced to a minimum.

RADIATORS. These appliances, which in appearance are an improvement of the ordinary hot water radiator with the addition of a base containing the burners, may function by their surface being heated by the vaporization of the small quantity of water they contain, but are now little used. The modern radiator operates without water or steam, the combustion gases from the burners heating the vertical tubes.

The water vapour radiator provides the greater concentration of heating surface and is therefore more economical in space

than the vapourless type. When the question of space is unimportant the vapourless type has the advantage owing to its lower cost and simple form of construction. They are both equally suitable for warming spaces such as offices, shops, cafés and halls or corridors.

As with other types of flueless heaters, radiators are open to the same criticism in respect of their effect upon the atmosphere, and

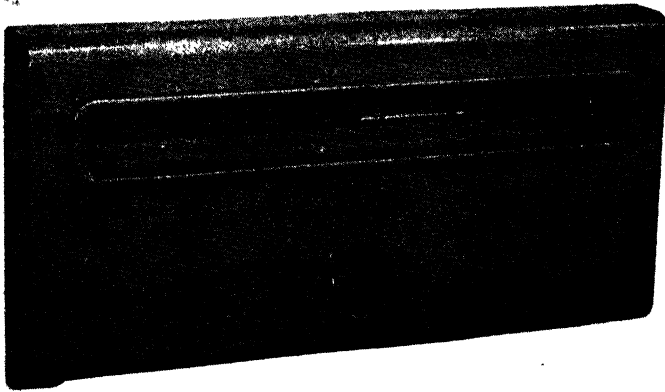

FIG. 74. BACKGROUND FLUELESS HEATER

An appliance that gives out heat at the outlet as warm air and is specially designed to take the chill off a room, halls or passages, and is of such a shape that it can frequently be fitted under a window.

(*The Gas Light & Coke Co., Watson House*)

for this reason extra heat may be necessary for the additional ventilation required.

HEATERS. The two principal types of this appliance are the unit heater and the ordinary convector heater. The air flow with the former is mechanically produced and that with the latter circulated by natural induction.

The unit heater, which transmits heat produced from the gas in a similar way to that described for use with hot water or steam, may be utilized when this means of supplying heat is not available. In other respects it serves a similar purpose to unit heaters in general, and is installed in the same way with the addition of a flue when necessary for the discharge of combustion gases.

The convector heater is constructed to provide a more rapid circulation of warm air as compared with the radiator. This is obtained by admitting extra air through the bottom of a metal

casing containing the burners and discharging it at the top. The appliance may be used for heating spaces as described for radiators but is usually more attractive in appearance. Fig. 74 illustrates a particular type of this appliance.

HOT WATER HEATERS. Appliances for heating water are either of the instantaneous non-storage, or storage type, according to whether the water is heated as it is used or is heated at other times and stored for use as required. They may be either of the non-pressure or pressure type, the water control tap being on the inlet and outlet of the appliance respectively.

Non-storage heaters of the non-pressure type are those of the familiar "geyser" pattern whose features are well known and which, when of sufficient capacity and installed under proper conditions, can be relied upon to give satisfactory service. A heater of improved design but of the pressure type is available with automatic instantaneous action which may be used to serve a number of taps. The opening of a tap produces a ready supply of hot water but it is not intended that this should be sufficient to serve more than one tap simultaneously.

Amongst the many types of non-storage heater are those that supply small quantities of boiling water, providing a quicker and more economical means for this purpose than a kettle and gas ring. They are convenient for use in cafés, surgeries, and hairdressers' establishments.

Heaters of the non-storage type have a thermal efficiency of between 70 per cent and 80 per cent. They may be supplied with water from a feed tank or connected direct to the cold water supply main according to the water supply companies' regulations.

The storage heater, as the name implies, accumulates hot water as it is heated over an extended period, providing a reserve supply for use at several taps simultaneously. The two principal types of this heater vary according to their rate of gas consumption. They are obtainable in storage capacities up to about 40 gallons.

The recovery rate of heat supply varies from about 5 to 35 gallons per hour raised 90 deg. F. with gas consumptions of approximately 10 to 90 cub. ft. per hour. The heaters are thermostatically controlled, and with the low consumption type a flue is unnecessary.

Storage heaters may be used to greater advantage when installed as a means of airing linen cupboards. Instantaneous heaters, particularly those of the single point type, require less heat than the storage type owing to smaller thermal losses.

Gas circulators may also be used as summer auxiliaries to solid fuel installations as described on page 162, para. 2.

4. Electrical Appliances. The need for a heating appliance that can be utilized without a flue and space for fuel storage, and at the same time provide warmth quickly with the minimum of inconvenience, has been largely responsible for the increasing use of electrical appliances. This increase in demand has led to the production of a range of types presenting a wide variation in their methods of application.

The original type of electrical warming appliance was introduced to provide radiant heat quickly and took the form of a luminous heater designed to emit heat by medium temperature radiation. Subsequent developments produced appliances to function by other methods of heat transmission, and their utility is now equal in many respects to that of appliances consuming other classes of fuel.

Unlike these latter appliances, the thermal efficiency of the electrical heater remains at 100 per cent irrespective of the method used in making the heat available. The rate of warming the atmosphere in a room, will, however, vary as with all other types of appliances, since this is dependent on the size and temperature of the heating elements and the provision made for circulation of the air warmed by them.

Those appliances that rely upon the transmission of heat by the use of exposed luminous elements, as in the firebar and reflector types, are normally restricted in use to small spaces such as living rooms, private offices, small shops, and cafés. In larger commercial buildings it is usual to employ an enclosed non-luminous element, as used in convector heaters or radiant panels, in order to provide more equable distribution of warmth and reduce the risk of fire.

Owing to the current expense of direct electric heating, the appliances for general heating purposes must be restricted, but they are particularly suitable for intermittent heating. When used for short periods only, the benefit to be derived from an appliance producing immediate radiant heat is such as to make its use as convenient and often as economical as other appliances. For continuous heating electricity is also now in greater demand owing to the scarcity of solid fuel and domestic help. When the heating periods are more prolonged, it becomes essential to make the fullest use of building thermal insulation owing to the greater expense incurred for the heat.

One great advantage of electricity as a medium for space warming and hot water supply is the ease with which it may be controlled. It is made available by the touch of a switch, and controlled

by automatic devices that often form part of the appliance. Regulation of heat output in this way can not only ensure constant air temperature but also conserves the current—an essential requisite in the use of a heating medium of relatively high purchase cost.

The principal types of electrical appliances are as follows—

FIRES. There are many types of luminous radiant heaters ranging from those of the firebar type that embody coiled resistances fixed

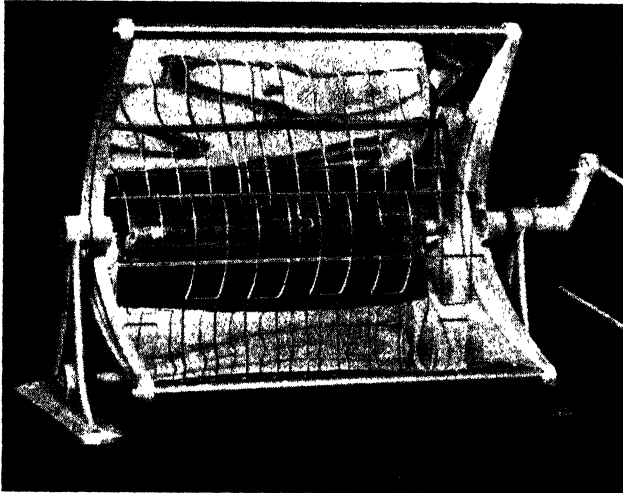

FIG. 75. ELECTRIC FIRE OF THE REFLECTOR TYPE

An appliance suitable for wall fixing with means of adjusting the direction of radiation.

(*Ferranti, Ltd.*)

on the face of a refractory material to the type with resistances wound round a refractory, as in the bowl or parabolic reflector appliance shown in Fig. 75. The reliance upon an exposed high temperature element for the transmission of heat limits the application of this type of heater.

Each of the numerous appliances of this description possesses some small feature of particular appeal to the purchaser. Amongst the various designs are those intended to reproduce the effect of a coal fire for the benefit of those who like this effect.

As a means of warming, luminous radiant heaters are effective in providing localized heat quickly for intermittent use. This is supplied with the firebar type in nearly equal proportions of radiation and convection, the former increasing up to 70 per cent with the reflector type. The appliance normally stands upon the floor or

is built into a tile or other surround on the wall. The reflector type may be fixed overhead as a convenient location for short period warming in small bedrooms and bathrooms, but is not altogether satisfactory in this position. Reflector type heaters may also be embodied in centrally heated hot water radiant convectors as a means of "topping up" the background warmth provided by this appliance.

As a convenient method of warming for short periods, luminous heaters have their greatest use in living rooms or bedrooms. For general heating purposes, they cannot be considered suitable owing to the unequal distribution of warmth, the high temperature radiation, the disadvantage of an exposed red hot element, and, because of this, the difficulty often experienced in allocating positions for their accommodation.

RADIANT PANELS. Appliances of this description, which rely upon radiation for the greater part of the heat transmitted, are of the non-luminous type since they function at surface temperatures ranging from about 100 to 300 deg. F. according to their form of construction.

Although all depending upon the use of a plain flat surface for the emission of heat the types vary in the class of material utilized to form the panel and the means adopted to heat it, together with the method employed for its installation in a building.

In the high temperature type, for example, the resistance element is enclosed in a specially selected material comprising the panel surface itself, which is attached in an inclined position to brackets for fixing to convenient vertical structures. It is usually positioned at a high level in the space to be heated in order that full use may be made of the comparatively high temperature radiation, which because of its intensity can produce comfortable conditions with a lower air temperature. For this reason it gives increased economy when extra ventilation is required and is suitable for installation in such buildings as showrooms, workshops, class rooms, and assembly halls.

Low temperature types of panel differ to some extent in their form of construction and method of installation. One type, for instance, comprises a metal plate with heating elements attached behind with an insulated backing, and is intended for superimposing on wall and other convenient surfaces, such as those normally covered by the skirting. These panels operate at similar temperatures to a hot water radiator, but like the high temperature type of panel

this increases when the emission of heat is restricted by curtains or furniture and may give cause for complaint.

Another type of panel operating at a temperature of about blood heat consists of a fabric in which are embedded the electric resistance wires. This material may be applied to walls or ceilings in a similar way to wall-paper and produces the same effect as hot water heated panels. Panels of somewhat similar construction may be used as an independent portable unit where a source of radiant heat can be effectively utilized to counteract local cold spots.

Low temperature electric panels, by producing similar conditions of comfort to those of hot water panels, are suitable for installation in buildings where the latter type of appliance proves satisfactory, subject to the cost of electricity being appropriate.

RADIATORS. The heating effect produced by these appliances is similar to that obtained by a hot water or steam radiator when they utilize water, or water and vapour, as a medium by which to transfer the heat in the electricity to the appliance.

Alternatively, electric radiators may function without water or vapour, relying upon oil or the circulation of air through the appliance as a means of heat transmission. Other types are constructed of special material to act as a reservoir for heat so that they may function as thermal storage units with the object of consuming electricity at the lower rates of controlled supply.

As in the case of gas radiators, the electrical appliance using liquids or vapour is of more compact form than many other types of electrical heater of similar output, making it economical of space and of labour for installing. In other respects it must be regarded as a somewhat complex means of transmitting heat to air from electricity in view of the alternative methods now available.

CONVECTOR HEATERS. In this category may be included those of the tubular pattern, which in effect are the electrical equivalent of the hot water pipe and may, therefore, be utilized in much the same way as a means of heating. They are installed as single units, end to end, and in tiers, and arranged for switching by hand or automatically, either individually or in groups.

Tubular heaters may also be adopted for use in a casing, in a similar way to a hot water convector heater, when the tubes operate at high temperature. Convector heaters of the cabinet type, which may alternatively be fitted with a luminous or non-luminous element, are provided with openings at the top and bottom of the casing for the circulation of air (which may be arranged to provide low casing

temperatures) and when embodying thermostatic control they provide an economical and compact type of appliance. A heater of this description is shown in Fig. 76.

Other types of convector heater include the unit heater with

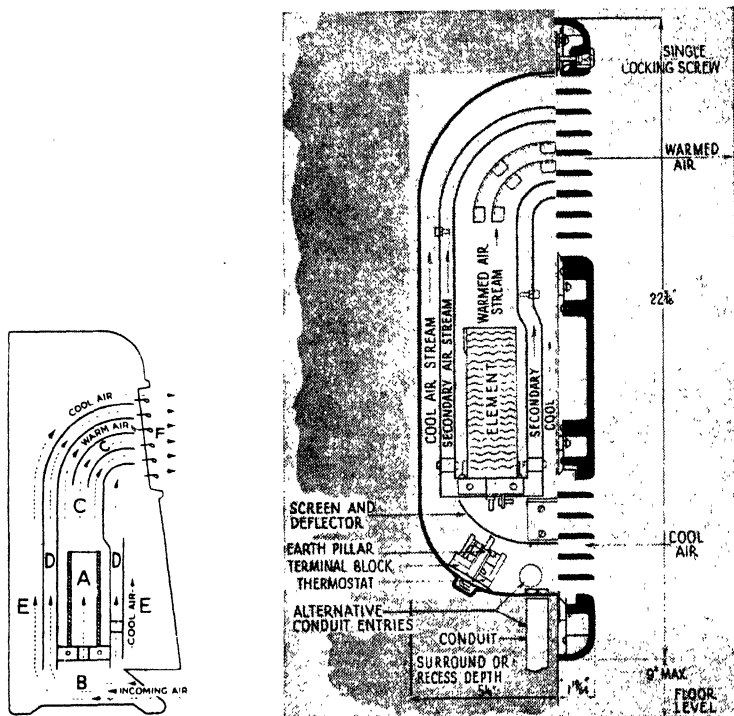

(a) Vertical cross section of floor, standing type heater.

(b) Vertical cross section of inset type heater suitable for building into walls, partitions and furniture.

FIG. 76 CONVECTOR HEATERS
(Thermovent, E. K. Cole, Ltd.)

electrically heated elements which may be used in the same way as those described for use with gas, steam or hot water. In addition to this industrial type there are others for use in smaller spaces which may be bracketed to a wall or stand on the floor, such as that shown in Fig. 77.

WATER HEATERS. Appliances for the supply of hot water are usually of the storage type in order to limit the electrical input. Instantaneous electrical heaters have been produced but are seldom used owing to their high rate of consumption and the consequent increase in the "maximum demand" for supply of current.

Storage heaters are either of the pressure or non-pressure type, according to whether the appliance is to be installed below or above

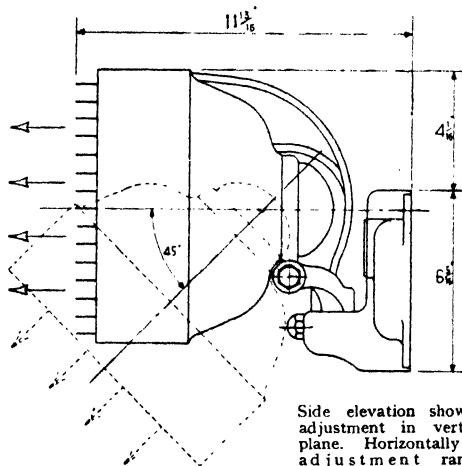

Side elevation showing adjustment in vertical plane. Horizontally the adjustment ranges through 120 degrees.

FIG. 77. UNIT HEATER ($2\frac{1}{2}$ kW)
(G.E.C.)

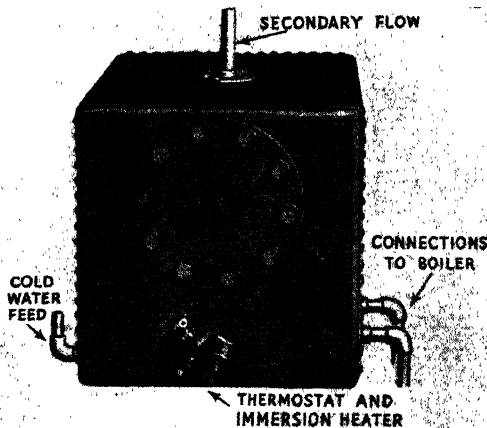

FIG. 78. HOT WATER STORAGE TANK
An arrangement combining the use of electricity and solid fuel for water heating.

the level of the taps to be served. Non-pressure heaters include those which embody their own open feed tank and ball valve, or include provision to restrict the rate of cold water feed. The pressure type is supplied with water from an independent feed tank in the

usual way, and is therefore similar in this respect to an ordinary hot water cylinder. A recent addition to the range of heaters is the "two in one" heater giving increased economy and convenience.

The storage capacities of the heaters range from about 1 to 40 gal. and loadings from about $\frac{1}{2}$ to 3 kW, the supply being thermostatically controlled to limit the water temperature below 200 deg. F.

Electrical water heaters are a convenient method of providing hot water when a supply cannot easily be obtained from a central system and when the rates for current are favourable. Owing to the ease with which hot water is made available their use is meeting an ever increasing demand.

For added convenience electric immersion heaters combined with thermostats may be fitted to the hot water cylinder of a centralized system for boosting purposes and to obviate the use of the boiler during summer or at other times when it is inconvenient to keep the boiler alight. The system to which it is applied should be without a secondary circulation as this increases heat loss and the consumption of electricity, and for the same reason the cylinder should be well insulated. Existing secondary circulations may be checked with valves when electricity is in use. Fig. 78 illustrates an arrangement of this description.

PLANS, SPECIFICATIONS AND TENDERS

1. Extent of Requirements. There are many factors that call for consideration before the actual installation of apparatus is commenced. One of the most important is a definition of the responsibilities to be undertaken, by both the purchaser and the contractor, in the execution of the work. This involves, in addition to the usual formalities, the provision of information to enable the exact requirements of the installation itself to be determined.

A misconception of the service to be provided by the extent or capacity of the apparatus, its general efficiency and durability, and also its type and arrangement, is the main reason for the inclusion of the unsatisfactory proposals often found in tenders, although these are not always apparent to the recipients. In the majority of cases, the contractor has received little or no guidance in the form of a specification, a bill of quantities, or even a schematic outline of the installation in so far as it affects the planning of the building. Because of this there is often little similarity in the work proposed to be undertaken by those tendering, and in consequence there is a wide disparity in the estimated costs submitted.

The receipt of tenders in the circumstances described is not only confusing but renders any just award of contract impossible until each scheme, specification and estimate has been carefully examined in order that the necessary adjustments may be made to place them on an equitable basis for comparison. It is, therefore, incumbent on the purchaser to supply adequate information for both his own and the contractor's benefit.

As accuracy in estimating the cost of apparatus depends to a large extent upon the planning of a building, drawings showing both the planning of the floors and constructional details of the building should be available. The latter are of particular importance since laborious calculations are entailed to determine the capacity of an apparatus in the process of extracting quantities from its planned lay-out, for costing purposes.

The supply of plans is also necessary to enable tenderers to submit with their tenders a set of prints or drawings showing the general lay-out of apparatus, together with any important dimensions of the plant which it is proposed to supply. These particulars should

include full information of the extent of the equipment, and should be sufficiently detailed to enable a true comparison of tenders to be made.

Since the capacity of an apparatus mainly governs its cost, it is also essential for precise information to be given regarding temperature and air change requirements, not only in respect of the exact number of rooms or extent of the building to be heated, but the actual temperatures and changes to be provided in each part of a building in accordance with the respective standards recommended. If this information is not forthcoming some discrepancy is likely to occur in the recommendations proposed, which will render the costs quoted incomparable.

It is, however, more often the exception than the rule for invitations to tender to be accompanied by a specification of the work required, or plans giving particulars of the extent of the installation, and it therefore becomes necessary, for the reasons given, for purchasers to provide an outline specification, or some brief particulars giving essential details. A summary is given below containing what are considered to be the more important details necessary to provide an equitable basis upon which to design and estimate the costs of apparatus. The particulars comprising the summary contain alternative and supplementary items, to be included or omitted, according to individual requirements. If no preference is felt towards the use of any particular method or type of apparatus one only of the alternative items listed (other than supplementary items) should be specified.

WARMING INSTALLATION

1. *Extent of Service*: Entire building or specific number of rooms or floors only.
2. *Type of System*: Hot water, steam, warm air, or fully-conditioned air.
3. *Temperatures and Air Changes*: In accordance with recommended standards or as otherwise required. (Specific requirements to be stated.)
4. *Fuel*: Electricity, gas, oil, coke, coal, or anthracite.
5. *Boilers*: Sectional, cylindrical, or tubular type. Independent or combined for use with hot water supply apparatus (if any). Hand fired, gravity fed, or mechanically stoked. Hand feed or mechanical feed of fuel from bunkers to hoppers or boilers.
6. *Automatic Temperature Control*: Centralized, zone, or remote method (with compensation for changes in outside temperature as required).
7. *Heaters*: Unit heaters, convector or column radiators (window pattern where applicable). Ventilating, open or encased. Heights permissible. Floor or wall fixing for column pattern. Steel or cast-iron material. Required number or positions of pipe coils in lantern lights or below skylights and elsewhere. Also heated clothing drying racks.

8. *Radiators*: Convector radiant radiators or wall pattern radiators.
9. *Radiant Panels*: Exposed or concealed type. Projecting or recessed, interposed or embedded fixing. Ceiling, wall, floor, or other positions. Surface temperature to be stated (i.e. low or medium).
10. *Circulating Mains*: Exposed to view or concealed wholly, or in part, in floors, wall chases, and elsewhere.
11. *Thermal Insulation*: Plastic composition or sectional class. Applied in boiler house only or to all ineffective heating surface.
12. Any special requirements.

HOT WATER SUPPLY APPARATUS

1. *Extent of Service*: Number and position of draw-off points required for baths, bidets, basins, sinks, showers, or any other purpose.
2. *Type of System*: Independent or combined with central warming boiler(s).
3. *Towel Rails*: Required number and position. Single or double top rail. With or without radiator sections. Chromium, nickle-plated, or enamel finish. Floor or wall fixing.
4. *Radiators*: Required number and positions. Temperature and air changes to be allowed.
5. *Heaters*: Required number and position of airing coils and heated pipe drying racks or rails.
6. *Circulating Mains*: Exposed or concealed. Galvanized finish or copper material.
7. *Fuel*: As for warming installation. Gas or electricity supplementary to solid fuel for intermittent use. (See page 162, para. 2.)
8. *Boilers*: Domestic hot water supply (direct) or central warming type (indirect). (See page 165, para. 3.) Method of firing.
9. *Storage Vessels*: Cylinders or calorifiers. (See page 165, para. 3.)
10. *Thermal Insulation*: As for "Warming Installation."

VENTILATING APPARATUS

1. *Extent of Service*: As for "Warming Installation."
2. *Type of System*:
 - (a) Natural—Fresh air inlets to radiators, wall, or roof ventilators.
 - (b) Mechanical—Extraction or fresh air supply only, or combined.
3. *Air Changes*: Number required. (Reference may be made to Table 111.)
4. *Centralized Fans*: Extreme quietness in operation or normally silent.
5. *Air Cleaners*: Dry or viscous type.
6. *Air Ducting*: Metal throughout building or partly in other materials. (Extent to be indicated according to facilities that can be made available to embody ductwork as part of material of building structure.)

COMPLETE AIR-CONDITIONING APPARATUS

In addition to the particulars to be supplied for ventilating apparatus, information should be given regarding any particular relative humidity necessary, the extent of cooling required, and any additional air cleaning that may appear desirable.

2. Submission of Tenders. The procedure to be adopted to obtain estimated costs of an installation is often best left to the discretion of the purchaser, who, from past experience, may be in a position to fulfil his requirements without difficulty. Others, however, may have experienced certain difficulties in this respect, due to one cause or another but arising, in general, from a lack of methodical means to secure the information required. The information that follows, therefore, is for the benefit of those who are uncertain of the best course to pursue to ensure that the description of the apparatus to be installed and the service it is to provide are compatible with the expenditure, and that in securing this assurance the minimum inconvenience is incurred before, during, and after installation of the apparatus.

If circumstances are such that the integrity of a contractor of good status can be relied upon to provide an installation of a high standard of design, material and workmanship at a cost requiring no verification, it is unnecessary for further action to be taken unless the purchase is being made on behalf of a public body or organization dependent upon public funds. In the majority of circumstances, however, it is not possible for a private purchase to be made under such favourable conditions, and recourse must be had to some recognized form of procedure to achieve the same ends.

It is not intended to discuss the relative merits of public and private tendering, although it is evident that some form of competitive quotation is usually necessary if it is desired to obtain a strictly appropriate cost of the work to be undertaken. What is of more importance is an assurance of rational tendering, to avoid misplacing contracts, to obviate numerous adjustments to tenders for the award of contract, and to prevent subsequent complications arising as the work of installation proceeds. This assurance is desirable not only in fairness to contractors, but in order to eliminate the wide disparity in costs frequently submitted for identical work.

Circumstances such as those described arise as the result of an endeavour to obtain the lowest price for an installation, by indiscriminately inviting the submission of two, and usually more, tenders based upon plans of a building, and in accordance with schemes and specifications prepared by the contractors. This seldom results in the receipt of estimates based on similar design, material and workmanship, which is the fundamental basis of fair competition. The sequel is seen in the wide divergence of costs quoted, due either to a difference in status of the contractors

concerned, to a wide variation in the service to be provided by the apparatus as proposed by the tenderers, or to the inclusion of superior features of design the merit of which may remain unrecognized or not appreciated as the cause of a difference in cost.

Even when the costs quoted closely approximate to each other, they are, on subsequent examination, sometimes found to be misleading owing to the omission of certain necessary items in one or more of the tenders.

The ultimate adjustment of the tenders to render them comparable in every respect often involves many modifications, entailing extra work for all concerned and delays which could have been avoided. The final outcome of obtaining tenders in the way described is that they are seldom of any true relative significance, and most of the work involved fails to achieve the purpose intended. Such work undertaken by contractors during an annual trading period not only represents wasted effort, but also in the aggregate a considerable sum of money and this, having to be covered in their trading expenses, ultimately reacts to the disadvantage of the client.

As there is no doubt that a competitive element in securing a tender is desirable to encourage superiority in design of installations when this is undertaken by the contractor, it is not suggested that any restrictions should be made in regard to the arrangement of apparatus itself provided any extra costs involved are made known and it otherwise conforms to requirements. Freedom in this respect gives contractors the opportunity to exercise their skill in designing systems producing a wider range of alternatives from which to make a selection. It is, however, necessary to obtain uniformity in other respects.

First it is desirable that information should be obtained regarding the relative status of contractors selected to submit estimates before issuing invitations to tender for a particular contract, and, secondly, some guidance of a definite character should be given regarding the type of apparatus required and the nature and extent of the service to be provided by the installation. The status of all the tenderers concerned should be similar to ensure that each estimate submitted is compatible with the class of installation required.

3. Award of Contract. A perusal of the plans submitted showing the proposed lay-out of installations will afford some means of assessing the relative merits of the different schemes covered by the tenders, but finality in this respect can be obtained only by reference

to the specifications to ascertain the full extent of the service to be provided, and this can be determined only when information of a specific character has been included.

To avoid disappointment in the value obtained from an installation it is necessary to abstain from the common error of attaching greater importance to first costs than to operating costs. The economic objective to be attained in the use of equipment is that which ensures the provision of a comprehensive service and that the annual expenditure incurred under working conditions is not excessive so that an adequate return on the capital investment may be secured. Apparatus must accordingly be selected that is not only certain to provide the essential atmospheric requirements of a particular building but will carry out these needs at a commensurate operating and maintenance cost.

To facilitate the comparison of estimates received it is necessary to have certain essential particulars provided in the specifications submitted. One of the most important items of information concerns the capacity of the installation. This governs the space temperatures to be provided, and should therefore include the thermal quantitative equivalents expressed in B.Th.U.'s or square feet of heating surface. Since these figures indicate the quantity of heat to be introduced by the apparatus into the various spaces over a given period they reveal conditions which can be guaranteed with greater certainty than air temperatures.

The more important of the items to be furnished are as follows—

WARMING INSTALLATION

1. Number and capacity of boilers or calorifiers, and percentage of reserve output included (for intermittent heating and emergency use).

2. Total area in square feet of heating surface provided by the circuits.

3. Number of heaters, radiators or panels and the total area in square feet of heating surface provided by them, together with their respective mean temperatures.*

4. Total area in square feet of effective heating surface as provided by any circulating pipes in spaces to be warmed.

5. Number and capacity of circulating pumps and h.p. of motors.

6. Superficial area of the apparatus covered with thermal insulation.

7. Approximate requirements of total length of trenches, wall chases, and number of holes through walls, floors and ceilings.

8. Any special requirements in addition to ordinary builder's work for brackets, bases, flues, etc.

* The air temperatures specified² should be obtained with the heating surface mean temperatures given.

HOT WATER SUPPLY APPARATUS

1. Number and capacity of boilers, calorifiers or cylinders, and percentage of reserve output for emergency use.
2. Number and description of draw-off points to be supplied.
3. Number and capacity of any circulating pumps and h.p. of motors.
4. Superficial area of apparatus covered with thermal insulation.
5. As items Nos. 7 and 8 for "Warming Installation."

VENTILATING APPARATUS

1. Number and capacity of fans and h.p. of motors.*
2. Heating surface provided by air heater.
3. Resistance of air cleaner. Number of cleanings or filter replacements anticipated per annum.
4. Number and total free area of inlet and extract registers.
5. As items Nos. 7 and 8 for "Warming Installation."

AIR-CONDITIONING APPARATUS

In addition to the particulars above concerning ventilation, information should be supplied regarding—

1. Maximum proportion of recirculated air allowed.
2. Outdoor and indoor wet bulb temperature conditions.
3. Refrigerator capacity and horse-power.

Information of the above nature, being mainly indicative of the capacity of an installation, and the principal factor governing its cost, is a reliable basis upon which to assess the relative value of the apparatus covered by the estimates. This information, in other words, is representative of the maximum quantity of heat, hot water and fresh or conditioned air capable of being supplied by the installation for the cost of its purchase, and upon its nature should be made the final decision of acceptance after all other features have been considered.

When making comparisons of particulars of the description given, it is advisable to do so on a cost per unit capacity basis, since both are variable factors in each estimate. This is ascertained, in regard to a warming installation, according to the relation the cost bears to the total quantity of heating surface provided by space-heating appliances and in circulating pipes, and is a ratio that may be expressed in shillings per square foot. In adopting this method it may be found that the estimate lowest in cost is, in point of fact, the highest when considered in relation to the amount of heating surface proposed to be installed, which in consequence may prove to be subnormal when compared with that of other estimates.

* Excessive horse-power will indicate abnormally small air ducts, and/or inefficient design of circuits in general for similar air volumes.

An example of how a brief examination of tenders for a warming installation can reveal the true cost of the main work to be undertaken is seen in the simple analysis illustrated in Table XIV. The particulars given show the disparity that may exist between tenders in relation to cost and capacity of apparatus for similar systems.

TABLE XIV
ANALYSIS OF TENDERS

	Tender number	1	2	3	4	Average
<i>A</i>	Amount of tender	£3,000	£2,700	£2,625	£2,475	£2,700
<i>B</i>	Total sq. ft. of heating surface in circuit pipes and space-warming appliances	8,000	7,500	7,600	6,280	7,345
<i>C</i>	Sq. ft. of effective heating surface (as utilized in space warmed)	6,600	6,370	5,940	5,600	6,130
<i>D</i>	Sq. ft. of effective heating surface per 1000 cu. ft. of space warmed.	16.5	15.9	14.8	14.0	15.3
<i>E</i>	Cost per sq. ft. of total heating surface $\left(\frac{A}{B}\right)$	7/6d.	7/2d.	6/11d.	7/11d.	7/4d.

A tender may be selected in several ways as regards cost such as on price alone (*A*) without reference to heating surface provided; on total amount of heating surface (*B*) without considering price; on the amount of effective heating surface in relation to the quantity of space warmed (*D*); or on the ratio of cost to the quantity of heating surface (*E*). This latter readily indicates the comparative costs as regards the capacity of the apparatus. The item (*C*) should represent an average figure, and the difference between (*B*) and (*C*) should not be abnormally below average. B.Th.U.'s may be substituted for the superficial area of heating surface when its mean temperature is also known, and when its type varies in each apparatus.

To assess the relative values of the estimates for hot water supply apparatus, assuming that the number of draw-off points to be provided is similar in each case, the gallonage capacity of storage calorifiers or cylinders may be used as a basis upon which to obtain some further comparison of values in relation to the general capacity of the apparatus. The cost per gallon of the hot water storage to be provided by each apparatus may, therefore, be obtained and the

relative values noted. Similarly, in regard to ventilating apparatus, the relative cost, on a volumetric basis, may be assessed, according to the total cubic feet of air handled by the fans after the number or total free area of air registers provided by each estimate has been verified as being similar. Alternatively the cost per square foot of register face may be used as an index.

Another item that should receive comparison in each tender is the class of material to be used for radiators and piping. The former may be pressed steel or cast iron, and the latter mild steel, wrought iron or copper of suitable gauge which may vary according to local water companies' requirements. The use of malleable or wrought iron for pipe fittings, and cast iron, steel or non-ferrous metal for valves and similar fittings, will also influence the cost of estimates. The items of materials excluded, as forming part of the incidental builders' work required, should be closely scrutinized.

A matter that also needs attention before acceptance of a tender is one that affects the original estimated costs on the completion of the contract. As the work of installation proceeds it may be found necessary to carry out modifications to the arrangement and extent of apparatus as originally proposed and shown on the contract set of drawings. These variations to the contract, which may include both additions and omissions to the original lay-out of equipment, require to be costed to enable adjustments to be made to the original contract price, and a procedure should be agreed before the contract is made as to how these eventualities shall be met.

Variations to a contract may be covered by means of supplementary estimates for the work before it is undertaken, but this is a method that may prove unsatisfactory for obvious reasons. An alternative method sometimes used for the larger contract is that which is based upon a "Bill of Quantities" in accordance with an agreed schedule of prices, but here, again, opinions differ as to the usefulness of such a method since there are ways and means of circumventing the purpose to be achieved by it.

The alternative to the use of a "Bill of Quantities" is known as the "Time and Material" basis, which enables the cost of the items of work to be assessed according to the amount of material and labour actually expended daily, as shown on the workmen's time sheets. These forms, which are rendered daily for the Clerk of Work's or other responsible person's approval and counter-signature, not only ensures that the labour involved is reasonably commensurate with the amount of material used (which is also disclosed for verification

purposes), but also afford a more reliable means of controlling the extent of charges to be added to the prime cost of the work to cover trade expenses and profit.

Finally, it is necessary to ascertain that the general arrangement of apparatus and schematic details of the system, as proposed on the plans, are in accordance with requirements, and that each tender embodies the necessary guarantees in connection with such items as air temperature or humidity and maintenance of plant. It is important that a definite guarantee be provided so that there shall be no misunderstanding of the obligations assumed by the vendor or the results expected by the buyer. Many of the complaints that arise concerning the performance of an installation after being put into operation can be avoided if a concise statement is made regarding its capabilities by the contracting parties at the time of tendering.

Terms of payment should also be clearly defined as should the fact that due regard has been given to any local authorities' regulations. Providing that such matters as the foregoing have been dealt with satisfactorily, that the "Conditions of Sale" are acceptable and that each contractor is prepared to enter into a formal deed of contract if required, the award of contract may be made accordingly.

PART IV

INSTALLATION OF APPARATUS

CHAPTER XVI

SPACE WARMING APPLIANCES

THE installation of equipment will effect the construction details of a building, and can be made to improve its æsthetic standards. A space warming appliance for example in addition to fulfilling its primary purpose efficiently, can serve as a decorative feature, or as the finish of a structural surface.

1. Heaters. The installation of heaters, irrespective of whether they take the form of pipe coils, finned elements or radiator sections, calls for precautions in fixing to ensure that they comply with certain needs regarding interior design, finish and maintenance, apart, of course, from the necessary conformity to structural requirements. These appliances demand a fixing that is both secure and durable, and, moreover, provision should be made for expansion and contraction, avoidance of obstruction and deteriorating effect on decorations, facilities for cleaning and adjustment, and concealment where necessary.

Heaters, when installed in the form of pipe coils, may be fixed in a variety of ways according to the purpose they are intended to serve. When utilized as overhead heating surface in such buildings as factories, they are either suspended from the ceiling structure or roof trusses by specially constructed hangers or supported from the wall or stanchions by standard type brackets. At appropriate intervals the run of piping is anchored and provided with intermediate loops or sets to counteract the effect of linear expansion due to temperature changes. The piping is graded throughout its entire length for the release of air, which is permitted to escape at a suitable point in a circuit through an open vent pipe or an automatic air release device.

Heaters that are installed in lantern lights for the prevention of down-draught are arranged in the form of a pipe coil or as a radiant panel. With the former arrangement the coil is bracketed to the surround below the lantern light and above the laylight if provided, and fitted with an independent air vent when the air cannot be released through the pipe connections to the circulating mains. When a radiant panel is used the fixing is made by one of the methods

described in Section 3 of this chapter (see pages 211-6). Both coils and panels require flow and return connections to be made from the nearest circuit mains, and they should preferably be concealed to avoid discoloration of adjacent surfaces.

Coil heaters that are to serve as clothing drying rails in utility or drying rooms may be installed with three tiers of horizontal piping at appropriate levels. The double top tier forms a rest for headgear, the second tier, to which clothing hangers are fixed, is used for coats, and the bottom double tier for footwear. At either end of the rack pipe connections are made for the circulation of hot water, and they are provided with stop valves for controlling purposes. The racks may be either bracketed from the wall or supported on tubular uprights from the floor if it is desired to use both sides for hanging. For laundry purposes drying horses can be installed in a similar manner, but with the omission of hangers and, if necessary, the substitution of a single cold pipe for the double top tier of coils. Alternatively, a drying closet may be provided by the installation of movable wheeled horses arranged to be withdrawn from above heated coils positioned below gratings in the floor.

Piping installed in the form of airing coils, for use in linen cupboards or stores, is located near the floor in a single or double coil, carried round two or three sides of the cupboard, and provided with ample clearance from the floor and wall for cleaning purposes. Heated towel rails are installed either with a flanged pipe fixing to the floor and with suitable wall stays, or by entire fixing to the wall by the use of pipe flanges suitably secured to this structure.

Whenever heaters are installed for drying purposes it is necessary to ensure adequate ventilation of the space in which they are fixed in order that they may prove fully effective. This entails the provision of air registers at high and low level, in the walls or door of the apartment or cupboard to be utilized for the purpose of drying, for the interchange of air under natural conditions of circulation. This may have to be supplemented by mechanical means when the quantity of clothes to be dried is extensive.

The fixing of unit heaters at high level is carried out in the majority of cases by suspension from brackets secured to walls or stanchions, or from hangers secured direct to roof trusses or steel joists. The levels at which the units are fixed will depend upon the height of the room or building in which they are to function and the velocity and temperature of the air discharged by the fans. The lateral disposition of the units in relation to each other and the building

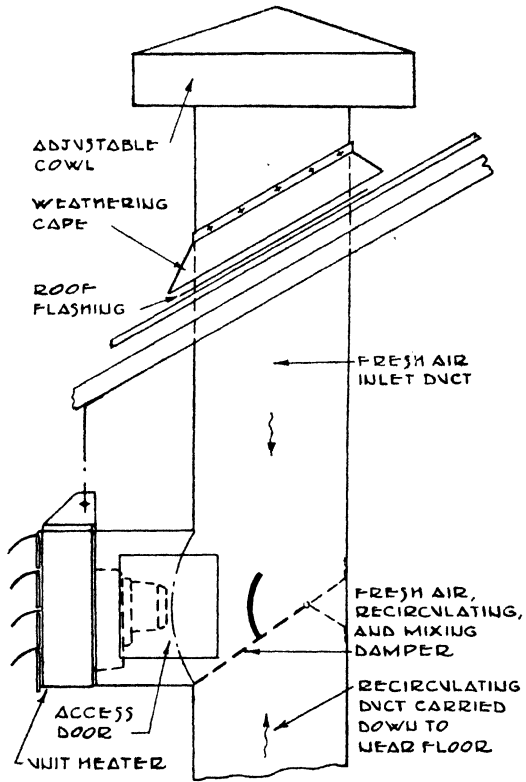

A. FRESH AIR INLET THROUGH ROOF

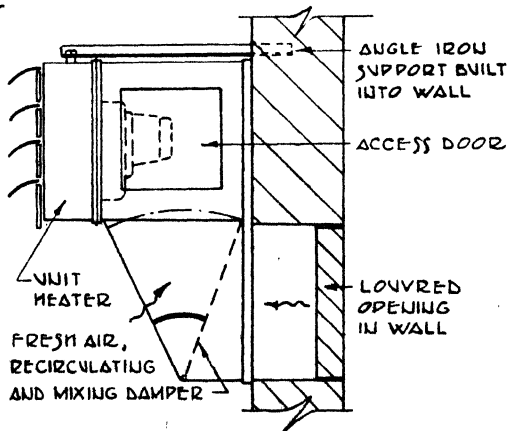

B. FRESH AIR INLET THROUGH WALL

FIG. 79. UNIT HEATERS

Arrangements of ducting for fresh air inlet and recirculation.

structure will also vary according to the shape of the space to be treated, the number of units to be installed, and the position of doorways, and on this account the positioning will be subject to different formations and directions of air discharge.

When units are to be arranged with special provision for the circulation of air from the lower levels, a length of sheet metal ducting is provided from a point near floor level to the suction side of the fan.

Units required to introduce fresh air for ventilation need a supplementary length of ducting from an opening in the external wall or roof for connection to that carried up from low level. At the junction point of the two ducts a bifurcating control damper is fitted to apportion the quantities of re-circulated and fresh air. One such arrangement is shown in Fig. 79.

The installing of unit heaters at high level together with their fittings and circuit mains represents additional weight to be carried by roof supporting members and due allowance should be made for carrying this extra load.

Radiators that are adapted for use as ventilating appliances either by the fitting of baffle plates to the front or between the sections of the radiator or by the use of a baffle type of adjustable air register in the

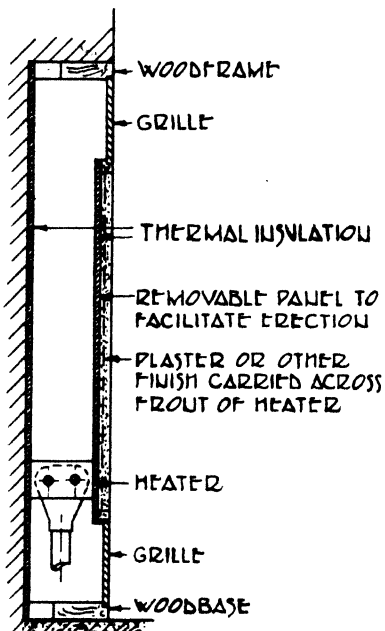

FIG. 80. CONCEALED HEATER
A method of fixing heater in recess, with front panel finished to match room decorations.
(Vectair)

wall opening behind the radiator, will require the opening in the thickness of the wall for the admission of fresh air to be in accordance with specified dimensions. The bottom of the opening on the external face of the wall should be on a level with the finished surface of the floor, and the opening itself through the thickness of the wall from this point should be provided with an upward set for weathering purposes. The external opening is provided with an air register as previously mentioned, and the internal opening fitted with an adjustable register of the box or hinged type to form an air baffle when baffle plates are not fitted to the radiator itself.

Convactor heaters of the encased type may be installed either as an independent unit—in which case they will stand clear of walls and other structures—or in contact with adjacent surfaces—in which case the rear of the casing may be omitted. As an alternative to this arrangement such heaters can be installed in wall recesses,

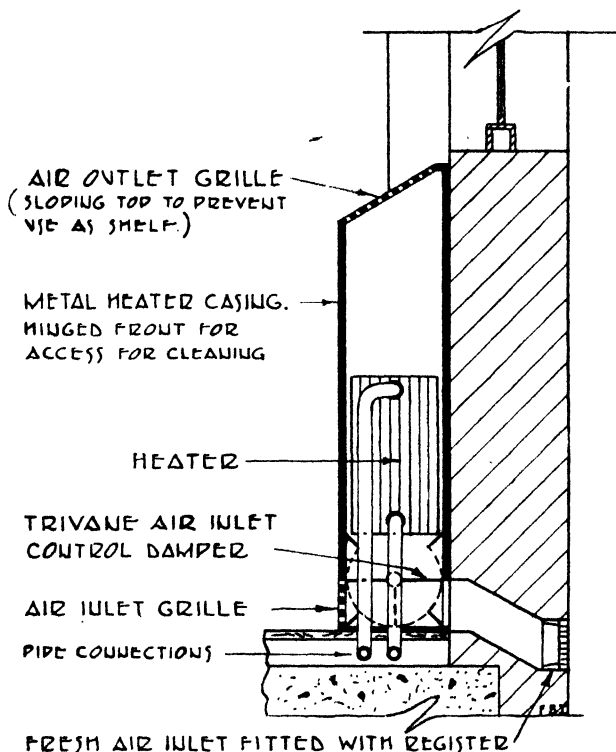

FIG. 81. ENCASED HEATER

An installing arrangement for entry to heater of either fresh or recirculated air and to shut off circulation completely.

when only the front and top of the casing need be used if the depth of recess is sufficient to prevent the front casing projecting beyond the main wall face. Heaters installed in preformed wall recesses may be fixed in the way shown in Fig. 80. Convactor heaters that are to be fixed against external walls may require these to be provided with openings for the entry of fresh air as shown in Fig. 81.

Steam convactor heaters that rely upon their casing as the chief means of controlling heat transmission should, whenever practicable, be installed in conjunction with fresh air inlet openings.

The actual method of fixing entailed for these appliances depends upon their type. Free standing units will generally be self-supporting, others will require stays or brackets to be secured to the building structure for their support.

The standard type of multi-column radiator of from one to six columns is installed by being supported either on the floor by feet which form an integral part of the radiator section or from the wall on cantilever brackets of a pattern suitable for the make of radiator used. When bracketed from the wall or other structures, which must be strong enough to withstand the radiator's weight, sufficient clearance must be provided from the wall and floor to permit thorough cleaning of both the radiator and its surroundings. The radiator must be securely stayed to the adjacent structure when not fixed upon wall brackets.

The pipe connections to a radiator may be made at opposite ends with both at the bottom, or with one at the bottom and the other at the top. Alternatively, they may both be made at the same end. The second of these methods is functionally correct with systems of gravity circulation, but the advantage so gained is not sufficient for this method to take precedence when others are found to be more convenient in particular circumstances.

Radiators that are to be fixed in recesses will require them to be sufficiently longer than the overall length of the radiators themselves to accommodate the control valves and connecting pipe unions, the actual dimension depending on whether the connections are made at opposite ends or at the same end. Any front covering in the form of an ornamental metal grille or hardwood panel should be detachable for cleaning purposes and for access to the air cock if concealed within the casing and when venting is not effected through the radiator connections. It is also necessary for sections of casings fitted to radiators that are fixed clear of the wall to be made readily removable for the same reason.

The openings in the top of a radiator casing and any in the side near the top, which are normally provided for the exit of warm air, should be omitted if it is intended that the casing should also serve to prevent discoloration of surrounding surfaces, which is caused by their contact with the rising air currents. Radiators installed without casings but provided with hoods or shelves above them to prevent this occurrence will require these fittings to have taper side cheeks to a depth of about one-quarter the height of the radiator for deflection of the rising air currents. A felt packing should be interposed

between the rear of the shelf and the wall to prevent the passage of warm air.

The control valve of a radiator, fitted either at the bottom or the top of the end section, may have the wheel spindle in a vertical or horizontal position according to convenience for operation. Control valves of the "concealed" pattern with only the spindle and

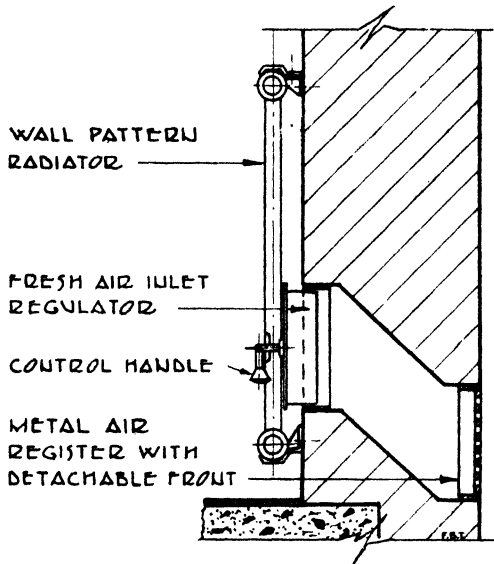

— SECTIONAL ELEVATION —

FIG. 82. WALL RADIATOR

An arrangement for use with fresh air inlet register.

wheel visible should be used if it is desired to secure an improvement in the general appearance of the radiator.

Column radiators of the window pattern, which are mainly intended for installation below window seats, require a clearance of not less than one inch between the rear edge of the seat and the wall. This opening is necessary for the passage of warm air which, in rising from the radiator, assists in counteracting down-draught from the glazing of the window. The opening also prevents a large proportion of warm air rising past the front edge of the seat, which may prove objectionable to the occupants. For the same reason it is necessary to provide a similar clearance when office desks are fitted against walls and radiators installed beneath them.

2. Radiators. The wall pattern radiator is primarily intended for

fixing to wall and other vertical surfaces, one example being shown in Fig. 82, but if such positions are unavailable it can be suspended from the ceiling by suitable hangers, although in this position some discoloration of the ceiling may occur, as with some types of radiant panel. Wall radiators fixed in this way, if of the convector radiant type with a continuous expanse of metal between waterways, will prove the

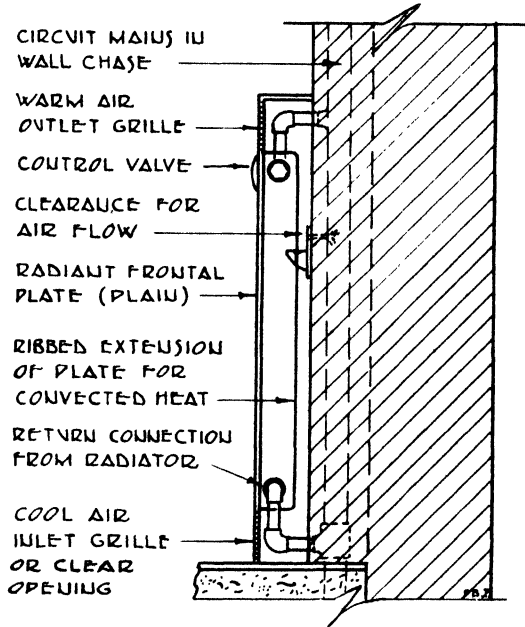

FIG. 83. CONVECTOR RADIANT RADIATOR
 Radiator fixed with front air outlet grille. Top outlet grille may be provided as an alternative position.

more effective because the maximum amount of radiation is obtained from them. When installed in its normal position against a wall, the sections of a wall pattern radiator may extend in a horizontal or vertical direction according to the form of wall surface available.

Convector radiant radiators with a plain frontal plate and finned back, which may be the kind shown in Fig. 83, are either installed clear of the building structure as an independent unit complete with casing or fixed in a wall recess such as may be formed below a window sill between reveals. With this latter arrangement the frontal portion only of the radiator is used, sufficient clearance being provided in the recess behind for the circulation of air, which may be supplemented by a fresh air inlet opening through the wall. The

pipe connections to this type of radiator are fixed behind the frontal plate for concealment, and a concealed type of control valve is embodied in the plate. Those appliances that embody a gas or electric fire will, of course, require the installation of gas and electrical services.

Whatever the type of radiator installed may be, it should be noted that these appliances should not be coated with paints containing a metallic base such as aluminium and bronze, as these will reduce the radiant heat emitted.

3. Radiant Panels. The various types of radiant panel that are utilized, either for fixing to the finished or semi-finished surface of a building or for concealment within the structure itself, vary in their method of installation according to the particular type used and the conditions under which it is installed. In many instances it may be necessary to adopt new measures in certain fixing details, to conform with the current progress made in forms of building construction, and the methods of installation to be described are therefore confined to those more generally utilized.

The cast iron type of superimposed panel that is constructed in standard sized sections for assembly to form a continuous length of panel may be fixed

to any surface sufficiently strong to carry its weight. The panel is supported by stay brackets of a pattern suitable for building into brickwork and concrete, for bolting to steelwork or for securing to other forms of structure. Its forward projection from the finished surface depends upon whether the panel is fixed against a plaster finish or otherwise, and in some types, if use is made of thermal insulation behind the panel. The exact length, when installed, is dependent upon the number of sections used, and the height varies in accordance with the standard dimensions listed. One type of cast iron panel shown with a superimposed fixing is illustrated in Fig. 84.

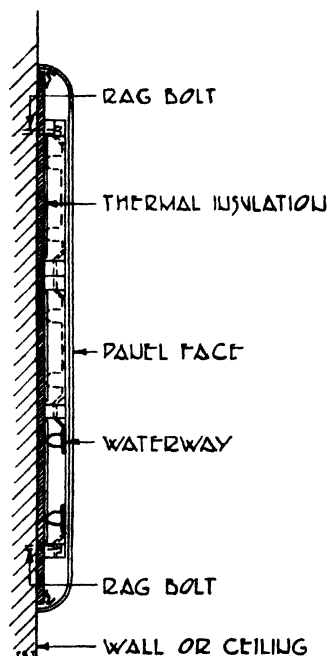

FIG. 84. SUPERIMPOSED PANEL
Installed on face of wall, ceiling, or other structure.

The length of a cast iron panel may extend in either a horizontal or vertical direction according to which is the more convenient for installation, and a number of panel sections may adjoin each other to form a continuous extended surface. The pipe circuits serving these panels should be concealed within the building structure so that they may be made invisible in the same way as the pipe connections to the panel itself are concealed behind the frontal plate. Panels installed in this way may be rendered inconspicuous when arranged symmetrically in relation to decorative features of finished surfaces.

Steel panels of the superimposed type that are constructed to special requirements in regard to size and shape will also vary in their final formation according to the particular conditions under which they are installed. When constructed with an entirely flat frontal plate, such panels are suitable for fixing in window or other recesses where it is possible for the edge of the plate to abut against or be concealed by other structures. Alternatively, one edge of the plate, or two opposing edges, may be curved to a right angle, so that they may abut against the same surface as the main body of the panel itself.

The curving of the top edge of the frontal plate of steel panels to be fixed below windows will enable it to abut against the window sill or, when sufficiently extended, the plate may be made to form the sill itself. Curving of the plate edge is also resorted to when the panel is constructed so that it may be installed to form a skirting, or a cove cornice, when it is fully curved concavely. Other forms of construction of this type of panel include a face-plate with a concave or convex surface, of limited radius, in order that it may be installed to conform with architectural curvatures of design.

It is important that care is taken in the fixing of superimposed panels to ensure that a satisfactory "seal" is made where the panel adjoins adjacent structures in order to provide for movement due to expansion. An overlap form of joint or the use of a suitable beading may be indicated.

The interposed type of panel is accommodated as a semi-independent unit in spaces between main structures and their finishing materials, and is installed according to the particular form of construction that is embodied in this type of panel. Panels constructed of specially sectioned tubing housed between carrier plates and expanded metal are either fixed upon or recessed within the underlying surface to which finishing materials are applied for the



FIG. 85. INTERPOSED PANEL ELEMENT ERECTION
Elements fixed to stanchion cover ready for application of finishing material.

completion of the building structure, as shown in Fig. 85. The finishing material is applied direct to the expanded metal of the panel forming a keying for the adherence of plaster or setting compound and this is undisturbed by any movement of the tubing which is left

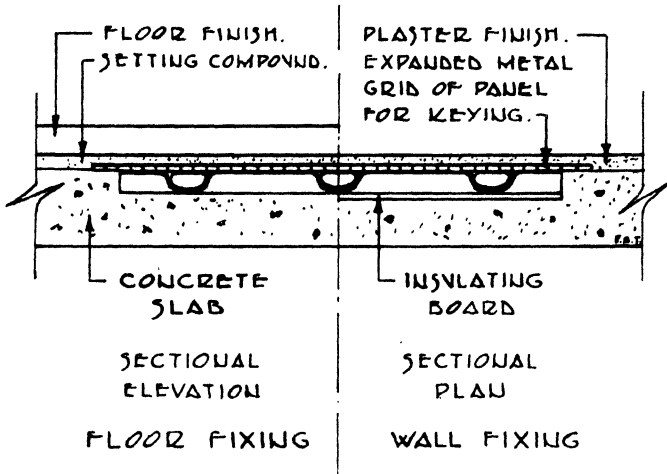

FIG. 86. INTERPOSED PANEL
A method of installing a panel in a concrete floor or wall.

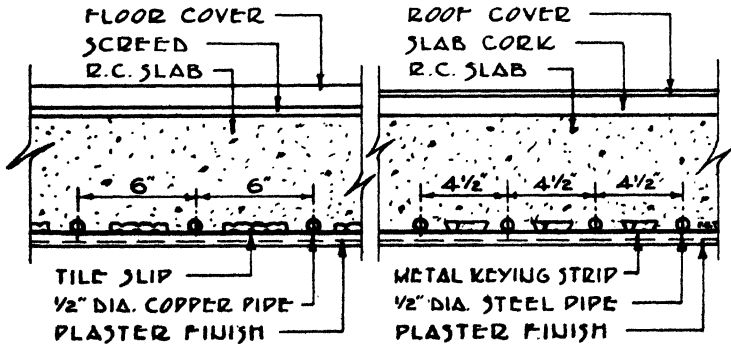

FIG. 87. EMBEDDED COIL PANEL
Alternative arrangements for ceiling coils in reinforced concrete slab.

free to expand or contract according to its temperature. This panel, for example, when installed in the form of a "border" below flooring with a concrete base, may require the formation of a shallow trench for its accommodation to provide sufficient space above for the overall level rendering of the concrete finish, or the application of setting compound for other classes of finish as shown in Fig. 86.

The embedded type of panel that is installed either within the structure by encasement in concrete cast in situ as shown in Fig. 87, or in the thickness of the plaster finish, being of coiled or gridded tubular construction only, requires little variation in the method of



FIG. 88. PANEL WARMING COILS IN POSITION FOR EMBEDDING IN CONCRETE

(By permission of Invisible Panel Warming Association)

fixing. The $\frac{1}{2}$ in. bore tubing may, however, be embodied in suitable precast materials for either superimposing or interposing in the construction of a building, when erection is by prefabrication.

Steel tubing laid in concrete floor slabs, stanchions and beams may be regarded as additional reinforcement.

Embedded steel ceiling panel coils, when encased in the concrete soffit of hollow tile flooring slabs and other classes of flooring material, are laid in position upon the shuttering as seen in Fig. 88, and welded

joints made from the coil to the supply connections. Grooved tile slips or grooved rubber sheeting are also laid upon the shuttering, between the pipe coils, to form a keyway for plastering, which is applied in accordance with specified requirements. The coil and feed connections are then subjected to the usual hydraulic test pressures, after which the laying of the flooring is commenced. Panels of copper are generally installed as one continuous length of tube between the points of connection to the circulating mains.

Panel coils or grids that are installed by being embedded in the thickness of plaster finishes to ceilings, walls and other surfaces are secured to the underlying surface by toggle bolts, or other suitable fixings which are built into the concrete or brickwork in the positions necessary for the particular type of panel coil used.

Surfaces utilized as warming panels, by the circulation of warm air behind, require the provision of ducts or voids within the structure for the passage of air. These may be constructed of composite boarding material which is fixed in position ready for application of the finishing material. Alternatively, the ducts may be formed as an integral part of the structure itself by the use of hollow tiles or other forms of precast hollow concrete material.

Whatever may be the method used for the installation of the various types of panels described, it is necessary for some form of thermal insulation to be embodied in those fixed against external walls and ceilings. The class of insulation to be provided will vary according to the type of panel used and its location, either being inserted separately behind the panel or embodied as part of the building structure.

The decoration of radiant panel surfaces necessitates the use of finishes that are unaffected by temperature, and only paints that contain heat resisting properties should be applied to avoid discoloration, blistering, or flaking. Plastic paints may be used if desired.

Information concerning the arrangement of panel control valves is given in the next chapter.

CIRCULATING APPARATUS

1. Pipes and Fittings. The manner in which the installation of pipe-work will affect a building both in regard to constructional details and its general finished appearance will vary according to the type of system used and the provision made for its accommodation and the concealment of circuits. From the information to follow many of the requirements entailed to ensure that installing conforms to the standards now desirable will become apparent.

The disposition of circuits will depend upon the system used for the circulation of heat. Hot water gravity circulating systems, for example, require the pipework to be arranged so that the height of the circuits above the boiler plant conforms to that necessary for the circulation of water by this method. The condense return piping of steam systems will, in some cases, require to be treated in a similar manner. Accelerated hot water systems using pumps, such as that shown in Fig. 89, offer no restrictions in this way to the arrangement of the circuit piping, which may be installed irrespective of its level in relation to the boiler plant provided it is graded in the usual way for the release of air.

In addition to the necessity for taking precautions regarding the circuit levels of gravity systems, it is also necessary to avoid sudden changes in the direction of the flow of water, in order to minimize frictional losses. This entails the provision of bends of easy radius in the piping and branch outlets of an easy sweep formation, as opposed to the more compact types of "straight" fittings that present acute and immediate changes in the direction of the piping but which are permissible with a forced circulation.

Pipework may be installed with joints and fittings provided with screwed connections made with suitable jointing material, or secured together with a compression type of screwed union joint, similar to that shown in Fig. 90, and frequently used when light copper tubing is installed, which may also be jointed with a soldered fitting. As an alternative to the use of screwed joints, the connections for mild steel piping may be welded by the oxyacetylene or electrical process, particularly when joints are subsequently made inaccessible by the building structure, or when it is desired to dispense with

special fittings as is usual with high pressure work. Flanged bolted joints may be substituted for welding when conditions necessitate provision being made for the subsequent disconnecting of pipework for maintenance and other requirements.

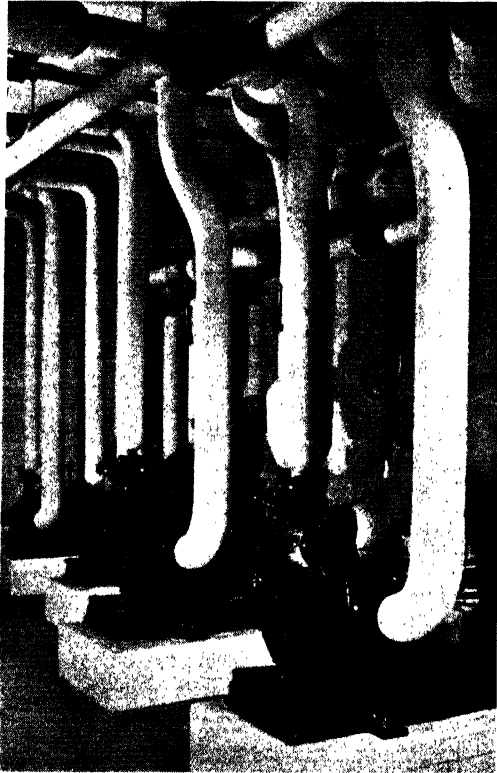

FIG. 89. STEAM TURBINE-DRIVEN CIRCULATING PUMPS

Pipework fixed clear of the face of building structures needs to be supported at intervals of between six and fifteen feet by the use of suspended or bracketed annular clips. Supporting rollers should be used, when long lengths of large diameter piping are installed, to allow free movement during expansion and contraction, and expansion joints, bends or sets, should be provided at suitable intervals to compensate for this movement (see Fig. 91). When copper tubing is installed, the use of clips or supports of gunmetal or brass is desirable to avoid deterioration from the electrolytic action that may otherwise occur. When the piping is to be left exposed to view

all supports require sufficient projection from their fixing surface to ensure that adequate clearance exists between such surfaces and

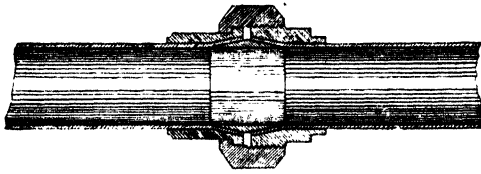

FIG. 90. COMPRESSION TYPE COUPLING
A fitting suitable for use with light gauge copper tube.
(Kongrip)



FIG. 91. PREFABRICATED PIPEWORK
The change in direction of pipe runs is used for expansion purposes.

the piping, or its insulating covering, for cleaning and other purposes.

Where pipes pass through floors and walls, it is necessary to build in sleeve pieces to enable the finishing material to these surfaces to

be made good around the opening without fear of subsequent disturbance due to the effect of heat and movement of the piping. It is also desirable to fit cover plates around the piping against the sleeve to provide a satisfactory finish and to prevent the transmission of sound through the opening. Pipes passing through roofs must also be fitted with sleeve pieces to provide a raised surface above the level of the roofing, for the making good of flashing or asphalt. In addition, a suitable hood needs to be fixed around the pipe above the sleeve to complete the weathering of the opening.

Circulating piping may be concealed by installing it in incidental or specially provided voids that can be conveniently arranged in the construction of a building, and also by making it form an integral part of the structure itself. Vertical pipes are most commonly accommodated within wall chases with a detachable or permanent cover of wood, plaster or other finishing material applied to expanded metal. Alternatively, they may be fixed behind the woodwork casing of stanchions, or embedded within the concrete cover to this steelwork when the pipes are of low temperature systems.

Horizontal pipes that require to be fixed throughout the intermediate floors of a building are usually accommodated within the floor structure, either by being embedded in the concrete or interposed in the space between this material and the finished flooring surface, as when wood boarding is used. Horizontal circulating mains that have to be positioned at the top and bottom of a building may be concealed in basement floor trenches, or above false ceilings to passageways, in roof voids, and on roof flats.

The vertical connecting piping to concealed radiant panels is normally installed in a similar way to the circuit piping itself, with provision made at a convenient position in the thickness of the wall for the accommodation of control valves for hand or automatic operation. The valve will require to be made accessible by the provision of removable covers to the valve wall box for inspection and maintenance purposes.

The general lay-out of main circuit piping and the principal branch circuits entails facilities being provided at the junction points of the circulating piping for access to isolating and regulating valves and also emptying cocks. These fittings, which are provided for the purpose of balancing the circuits on completion of the installation and to facilitate maintenance or subsequent alterations and additions to the circuits, must not, therefore, be concealed by the building structure unless suitable means of access is provided at each position

necessary. Similar facilities will be required for the isolating cocks provided in each branch connection from circuit mains to bib cocks supplying hot water to sanitary fittings.

Circuits that are installed between buildings may be run overhead on suitable supports, the pipes being well insulated and protected with a weatherproof finish. When the mains are run underground they should not be buried in the earth unless a protective impregnated coating of proved durability is first applied. This precaution, although offering resistance to corrosion, does not lessen the difficulty

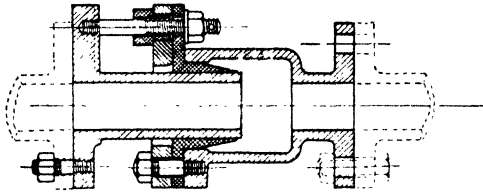

FIG. 92. ANTI-VIBRATION PIPE COUPLING
A coupling for suction and discharge connections of pumps.
(*Pulsometer Engineering Co., Ltd.*)

of detecting suspected leaks when the mains are not readily accessible. The alternative is to house the pipes in a conduit of brick, concrete, or other suitable material.

In certain classes of building such as hospitals, theatres, and hotels precautions have to be taken to minimize the transmission of sound by vibration in the circuits set up by the working of circulating pumps. This may necessitate inserting flexible couplings in the suction and delivery pipe lines near the pump for the purpose of insulation. These may be similar to the type shown in Fig. 92. It is by attention to details such as these, and others already mentioned, that the system as a whole can be made to function satisfactorily. Such components as flexible couplings can be made to take their place as part of a general scheme planned for the betterment of acoustical conditions throughout those buildings where this is of importance.

Paints used for coating the effective heating surface pipework should be restricted to those without a metallic constituent for the reason mentioned in regard to the painting of radiators. The final coats of paint, applied to the main pipe circuits (or its insulating covering) where such occur in appropriate places, should vary in colour according to the service they provide. This differentiation in colour finish will facilitate identification of the circuits of the various systems installed in a building when any subsequent investigations have to be carried out.

2. Ducts and Registers. The installation of ductwork in certain respects offers wider scope than that of pipework owing to variations in the material used for its construction. This advantage enables the ducting to be fixed as a separate entity to the main building structure or embodied in it by integration according to whichever arrangement proves the more practicable. On the other hand, the comparatively larger dimensions of the ducting make it less easy to install because additional space is required for its accommodation and added care must be exercised in the methods adopted for its erection. It becomes necessary therefore to consider alternative means of constructing the ducting at the time of planning the building structure so that provision may be made, if necessary, for its installation during the initial stages.

Ducting that is to be installed as an independent unit by being fixed in position after completion of the main building structure is usually made of galvanized sheet metal in suitable lengths ready for connecting together on the site. The fixing, when the ducting is positioned at high level, may be by suspension from ceilings or joists and trusses or by wall brackets, each located at intervals appropriate to the gauge of sheeting used in the making of the ducting, and provided with sound insulating hangers where necessary. When fixed at floor level, support must be given to the ducting at regular intervals if it cannot rest continuously upon the flooring structure.

Ducting that is to be fixed externally, such as on roof flats or against walls, may be obtained ready for erection in the form of precast lengths of composite material that is impervious to the effect of weather and, therefore, requires no protective covering, such as is necessary to ensure the same durability when sheet iron is used. This class of material or copper and suitable alloy metals also may be used when greater permanence is required because of their resistance to corrosion. Prefabricated materials are used as an alternative to brick or partition slab construction, especially when it is desired to expedite the completion of a contract.

Ducting built up on the site with concrete, brickwork, coke breeze slabs and other forms of partitioning material, may frequently be made to embody part of the building structure when positioned adjacent to walls and floors or ceilings in order to economize in material, labour, and space. By this means two, and sometimes three, sides of a duct may be formed by the juxtaposition of building surfaces. The formation, in part, of lengths of ducting may also be

achieved by utilizing voids, casings to stanchions and beams, and by enlargement of spaces below finished floor surfaces, in addition to the provision of spaces above false ceilings. Sheet metal ducting may be

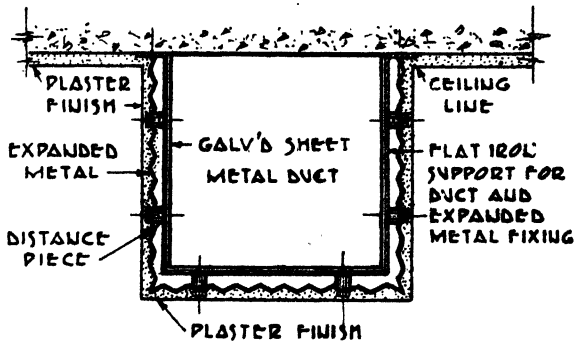

FIG. 93. ENCASED METAL AIR DUCT

A method of concealing a sheet iron duct as a false ceiling beam.

concealed by the application of expanded metal with a plaster finish to form a false beam or column, as shown in Fig. 93.

Main distributing ducts that are required to serve branch circuits throughout a building may be installed, in order to save space within the building, in the form of brick or concrete conduits below basement or sub-basement floors. This practice should be adopted whenever the structural design of a building permits of such an arrangement, both for the reason already given and to ensure concealment, which may be difficult to achieve by other means.

All ducting that is constructed on the site, whether of concrete, brick, precast cement slabs, or other materials of this description, will need to be formed with easy radius bends and branches where changes in direction occur if these are not fitted with deflectors, and the duct must also be gradually tapered where a change in its cross-section takes place. The cross-section of ducting when it cannot be made circular should preferably be square, but some latitude is permissible in this latter respect provided the section is not made excessively

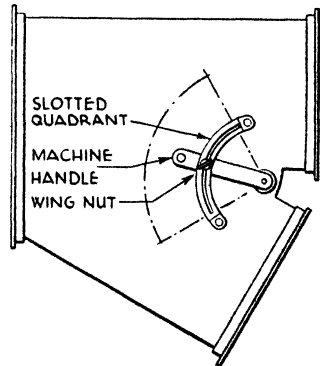

FIG. 94. DUCT-REGULATING DAMPER

Fittings of this description in a duct junction when concealed within the building structures should be made accessible for adjustment purposes.

rectangular resulting in inordinate frictional losses in the flow of air. For the same reason the internal surfaces of the ducting should be rendered smooth with a cement finish when this or other suitable surfaces are not provided as part of preformed blocks. A fine face to a duct, however, can be produced by good concreting and if the shuttering is carefully selected and positioned. At main junction points and other positions in the ducting, irrespective of the material used in

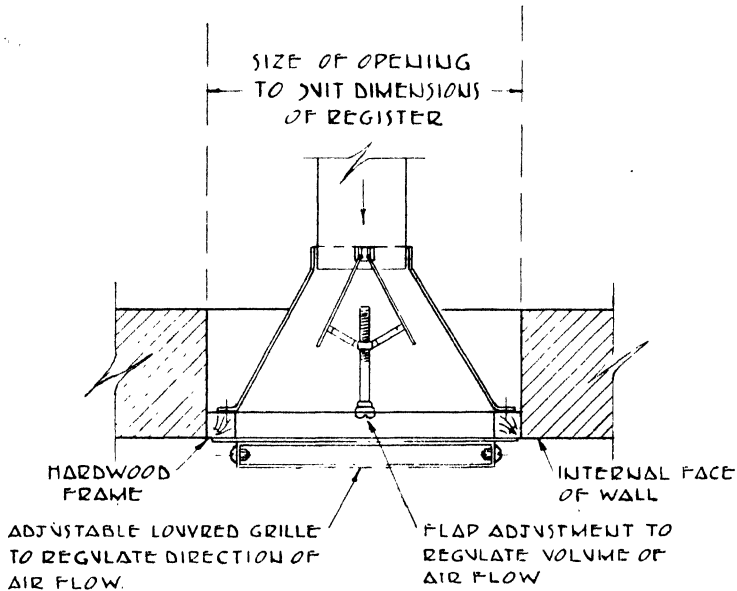

FIG. 95. FRESH AIR INLET GRILLE

A typical method of terminating air supply duct at face of wall.

their construction, where reheaters, automatic controls or regulating dampers are fitted, provision must be made for access to this equipment. Fig. 94 shows a junction piece of ducting fitted with an adjustable damper to which access should be provided.

The provision to be made in the various parts of a building for the discharge from ducts of air to the spaces treated or its intake to the ducts will depend, for the type of delivery and extract outlet used and the nature of the fixing entailed, upon the method of installing adopted for the ducting. Sheet metal ducting that is left exposed to view may have outlets fitted with a grille attached direct to the face of the duct, or to a short, flanged extension piece from the outlet opening when the duct is concealed within the finishing structure.

The grille itself may have plain or ornamented openings, provided its free area is not unduly restricted, and when it is desired to vary the direction of the air discharged, may be of the adjustable type. Alternatively, conditions may require the use of a diffuser or a deflector fitting, instead of a grille or register fixed to the outlet, to break up the flow of air or discharge it in a pre-selected direction. A typical method of terminating a duct and fixing a discharge grille to the wall face is shown in Fig. 95.

As an alternative to a metal register, air inlet and outlet openings that occur in concealed ducts may have the necessary apertures in adjacent walls and ceilings covered by a decorative grille formed of the finishing material of the surfaces by the use of plaster, woodwork, and other suitable substances. Outlets of considerable size are often left uncovered by a form of fluted treatment, or covered by an ornamental disc or otherwise rendered inconspicuous, being generally made to conform in different ways to the general scheme of ornamentation. This is seen, for example, in the proscenium and other parts of theatres. They may also be provided with devices embodying electric light fittings.

Ducts installed in places of entertainment, underground garages and other public utility buildings may need to be provided with fusible link-operated dampers and filters to comply with fire prevention regulations.

VENTILATING AND AIR CONDITIONING APPARATUS

1. Heaters, Air Cleaners, and Fans. Air heaters for use with ventilating apparatus depend for their location and fixing upon the nature of the ventilating system used. Some of the alternative arrangements adopted for air heating appliances, such as radiators or unit heaters, have been dealt with elsewhere, and the information that follows is therefore concerned with the type of heater normally used in conjunction with centralized ventilating and air conditioning plant.

There are exceptions, however, when the type of heater now under consideration may be used independently of a system of ducting, for example, when it is needed to fulfil certain industrial requirements. Under these conditions the heater battery may be positioned in the thickness of an opening in the wall of a building or apartment to be ventilated, and be provided externally with louvres and protecting grilles and internally with a suitable type of fan. A battery of air heaters may also be installed at the discharge end of a circuit of ducting or at some intermediate position between this point and the main intake fan.

In the majority of circumstances, however, when a distributing system of ducting is used, the heater is fixed adjacent to the main centralized fan, and positioned on the outlet side of the air cleaner. An alternative to this location is when zoning is adopted for air conditioning, in which case reheaters may be positioned in branch circuits. Heaters may comprise a number of cast iron, steel or copper sections assembled together in stacks to form a complete battery which is mounted on a floor base of suitable material or supported on a framework of angle or channel iron. When supported by the latter method with cantilever brackets from a wall or suspension hangers from overhead structures, it is sometimes more practicable to use a heater of the finned copper tube variety owing to its lighter weight. Heaters of this description are assembled together in units of single stacks of tubing contained in a framework suitable for bolting to other units to form a battery.

Air cleaners are almost invariably installed in the system of ducting adjacent to the fan and preferably on the intake side,

but there are isolated instances when it is arranged independently of ducting in a similar manner to an air heater, as already mentioned in connection with industrial requirements. The method of installing cleaners in general varies according to type since this will affect the facilities to be provided for maintenance purposes. They are frequently assembled with a housing framework which is suitable for installing by similar methods to those used for heaters, with the exception that provision must be made for access for cleaning or replacement of the filter sections. When the self-cleaning type is used, sufficient space must be allowed adjacent to the air duct for its oil cleaning tank, or pump and filters.

The method of installing fans must also be varied according to the type used and the purpose they are intended to serve. The simplest arrangement for fixing is seen in the small capacity propeller type fans, which are assembled together as a complete unit comprising the fan and motor, intake and discharge baffles, and mounting ring or brackets. This type of appliance is readily fixed, by means of screws or nuts and bolts, to the face of main walls, partitions and the glazing of windows, and in other suitable positions where the necessary opening can be provided. Other types of completely self-contained units, such as those housed in a metal box frame ready for building into the thickness of brick or concrete walls, are also easily installed since all that is required is a cement fixing.

Propeller fan appliances for the discharge or intake of air through pitched roofs may be installed either as a complete unit constructed ready for fixing upon roof ridges, or beneath the ridges by separate erection of the component parts. With the former appliance the fixing is made to the roof by screwed attachment of its base to a frame secured to the roof structure. With the latter arrangement it is necessary to provide suitable supporting framework inside the roof upon which to mount the fan together with the necessary air duct connection, and also a louvred air discharge fitting for erection upon the roof ridge.

The larger size of propeller fan, together with its incidental fittings, also needs to be installed separately. This will usually involve building in the opening a hardwood frame upon which to mount the fan and motor framework (unless this can be secured direct to main structures), in addition to fixing suitable wind baffles or louvres on the external side of the fan.

Fans that are used in conjunction with centralized plant, such as distributing systems for air supply and extraction and complete

air conditioning, require certain provisions to be made according to the particular conditions under which they will be called upon to operate. These fans for certain uses may be of the axial flow pattern, but for general purposes they are more usually of the centrifugal multivane type. This latter type is generally fixed upon a specially prepared concrete floor base, but it may also be bracketed from walls or have an inverted fixing from the ceiling. Axial flow fans

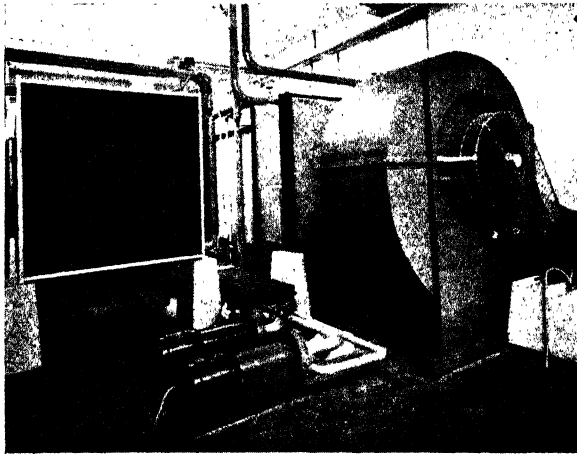

FIG. 96. VENTILATING INSTALLATION
Equipment showing fan, air filter, and heater.
(Keith Blackman)

are usually fixed inside the ducting, which simplifies their installation especially when space for fan accommodation is limited.

When fans are installed in certain classes of building, arrangements must be made to prevent, as far as possible, the transmission of vibration to the building structure, in addition to the usual precautions to be taken regarding low speeds and avoidance of casing drumming to ensure relatively silent running. Sound transmission, other than that primarily air-borne, is minimized by the use of sound insulating material, and this can be installed as described and illustrated in the next chapter dealing with machinery in general. For the same reason flexible canvas connections should be provided between the fan suction and delivery openings and the ducting.

The location of fans and motors will be mainly dependent upon the general lay-out of the system, but when circumstances preclude their installation within a building they may be positioned externally

and left exposed, provided the equipment is of the weathered type. The installation of variable speed regulators is also a desirable adjunct for the majority of installations in order that the maximum economy may be obtained in the operation of fans, and is a feature that presents little difficulty with the increasing use of electricity for fan motive power.

Fig. 96 shows one arrangement of plant embodying a fan, air filter, and heater.

2. Coolers, Humidifiers, and Unit Conditioners. Cooling appliance units consisting of a series of tubes supplemented with some form of secondary surface and connected together at each end with distributive headers, the whole of which is provided with a propeller type fan, are constructed in a similar manner to most unit heaters and are installed in much the same way. Coolers of this type, however, are normally positioned overhead as opposed to those types of unit heater constructed for floor fixing, but except for this difference, the methods of fixing a cooler in position are identical to those described for unit heaters of the type for use at high level.

Other types of coolers are those designed for floor mounting and provided with a centrifugal type of fan. These may be installed in the space to be cooled or remotely situated, and will require service connections as for the type fixed overhead.

Since the function of a cooler depends upon the internal circulation of some form of coolant, it is necessary to install flow and return piping from the cooler to whatever point is found most convenient for the coolant-producing apparatus. The running of a drain pipe from the cooler to a suitable point for the discharge of condensate from the coils will also be necessary, in addition to electrical wiring for connecting up the fan to the main supply.

Unitary humidifiers, such as those consisting of an atomizing jet positioned at suitable points throughout a building and which are sometimes used as an alternative means of humidification for industrial purposes, are connected at an appropriate level overhead to an outlet fitting provided in the water and compressed air or electrical distribution mains. The greater part of the installing work required for humidifiers of this description relates to the system of water, compressed air or electrical supply mains, which is erected in the usual manner with the addition of any air ducting that may be required.

The installation of humidifiers or de-humidifiers and incidental apparatus for complete air conditioning purposes, as used in conjunction with a distributive system of air ducting and the necessary

fan, heaters, refrigerator and other ancillary equipment such as shown in Fig. 97, follows the usual course except perhaps in regard to the form of construction used for the housing of the air washer. This housing, which is normally made of galvanized sheet iron

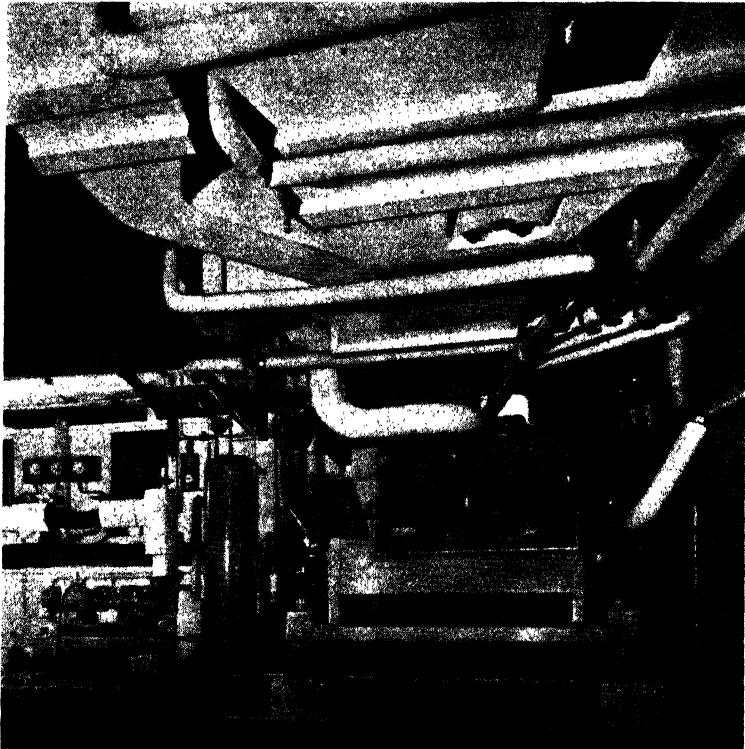

FIG. 97. AIR-CONDITIONING PLANT
Installation showing humidifier, refrigerating compressor, and insulated ducting overhead.
(Carrier)

complete with banks of spray nozzles, tanks, scrubber and eliminator plates ready for erection as a whole, may be constructed of other materials which are more durable and facilitate cleanliness. These include brick or concrete with an internally glazed tile finish, or glass bricks, each material being built up on the site, during which process the interior fitments are embodied.

The installation of the air and water heaters, circulating pump, refrigerator plant and automatic control gear is carried out in

accordance with the usual practice adopted for this equipment and does not affect building planning or structural details to any great extent excepting, perhaps, zoning needs and the refrigerator plant. The latter may work in conjunction with condensers of the type necessitating accommodation for this apparatus outside the building on the roof or elsewhere.

In view of the numerous items of equipment comprising the centralized section of an air conditioning plant and the sensitive mechanism of many of the appliances, it is desirable for this equipment to be installed in a chamber apart from the main plant, particularly boilers and any stoking or fuel handling plant. This will ensure the maximum operating efficiency by maintaining a state of cleanliness of the equipment and at the same time prevent interference by unauthorized persons.

Independent conditioning units of the cabinet type, which are used when the space to be treated is not sufficiently large to justify centralized plant with a system of air distributing ducting, or when there is insufficient space available to accommodate this type of apparatus, is comparatively simple to install. The extent of the work necessary for installation of these units will depend upon whether they are of the indirect or self-contained type.

Units of the indirect type require the running of refrigerant or coolant and hot water or steam and condense piping from a central point to each unit, together with drain pipes and electric wiring for the fan and automatic controls. An opening in the external wall adjacent to the unit will also be necessary for the admission of fresh air if desired. Self-contained units may also require this opening in addition to electric wiring and any water and drain connections, but the remainder of the work mentioned above will be eliminated.

CENTRAL BOILER PLANT

1. Boiler House Equipment. Many buildings present their own particular problems in regard to the installation of boiler house equipment. The ultimate planning, however, must correlate the plant requirements to the constructional design details of the building and it is only by a careful analysis of such conditions, together with an understanding of the basic needs of apparatus, that a satisfactory lay-out of the entire equipment can be assured.

The installation of central plant will vary according to the type of boilers and firing methods used, the class of fuel consumed, the system employed for the circulation of heat, and the provision necessary for the disposal of combustion gases. The essential features to receive consideration in the lay-out and erection of the equipment are facilities for ease of operation, compactness for economy in space, accessibility for inspection and maintenance, and precautions for the avoidance of excessive transmission of noise, vibration, heat and odours. Each of these factors will in turn affect to a certain extent the planning and erection of the boiler house.

A boiler house must be of sufficient size to ensure proper manual operation of the plant, and for this it is necessary to avoid positioning the various items of equipment solely with the object of enhancing its general appearance, economizing in pipework, or reducing to a bare minimum the amount of space necessary for its occupation. The foremost object to be achieved is to make accessible those parts of the apparatus requiring manipulation, such as furnace doors, firing equipment, control valves or panels and fuelling devices, and these must be appropriately positioned for co-ordinating the functions to be performed by the plant as a whole.

The satisfactory inspection and maintenance of a plant is of much importance and can only be assured if all parts that require attention are accessible with the minimum of inconvenience. This entails, for instance, arranging the plant in such a way as to make it unnecessary to remove one independent item of equipment to gain access to another, or partly to dismantle pipework due to the obstructive manner in which it has been installed.

Safeguards in the general lay-out of plant such as those mentioned

may seem comparatively unimportant but they explain what may appear to be extravagance in the space required for a boiler house. At the same time compactness in the lay-out of centralized plant is often of considerable importance both in regard to floor area and elevation. This can be obtained, not only by the use of certain types of equipment which are in themselves economical of space, but by taking full advantage of the saving to be made by bracketing apparatus from walls and by its inverted suspension from ceilings and other overhead structures—a procedure which may appear of little importance but is significant when applied to a boiler house or plant room of lofty construction.

The installation of boiler plant, inasmuch as it affects constructional details of the boiler house, will require the execution of certain work in builders' material to enable this part to be completed. This may include such items as chimney stacks, horizontal flues, bases, sumps and trenches, ventilators and insulation, in addition to steel joists and stanchions for supporting purposes, each of which will need to be constructed or erected in various ways.

The installation of sectional type boilers, with the exception of those of small capacity embodying a water-cooled base, will require the provision of a firebrick base, as will those boilers of vertical shell pattern and certain other forms of construction. These bases, which may be either laid flush with the finished floor surface or raised above it, should embody an ashpit, underlaid with insulating bricks when necessary, and be provided with an edging of glazed or blue bull-nosed bricks when laid upon the flooring finish.

The latter arrangement of base is preferable inasmuch as deterioration of metalwork due to contact with any water accumulating on the boiler house floor is avoided. Special care is necessary in the laying of bricks to ensure a level and even surface for cast iron sectional boilers in order to avoid setting up mal-alignment and distortion of the boiler section joints.

The cylindrical shell type of boiler will require special brickwork setting for the formation of side, bottom and rear flues, and also for the housing of the economizer, if utilized, including the provision of by-pass flues for use during economizer cleaning periods. Tubular shell boilers, of the self-contained horizontal type, are erected independently of brickwork by being supported on steel cradles, but when of vertical construction they usually require a brick base. In addition to the provision of bases and settings, boilers generating steam will require a blow-down pit in the boiler house floor suitably

baffled, trapped and vented, and a graded connecting trench from the pit to the boilers for the accommodation of blow-down pipes.

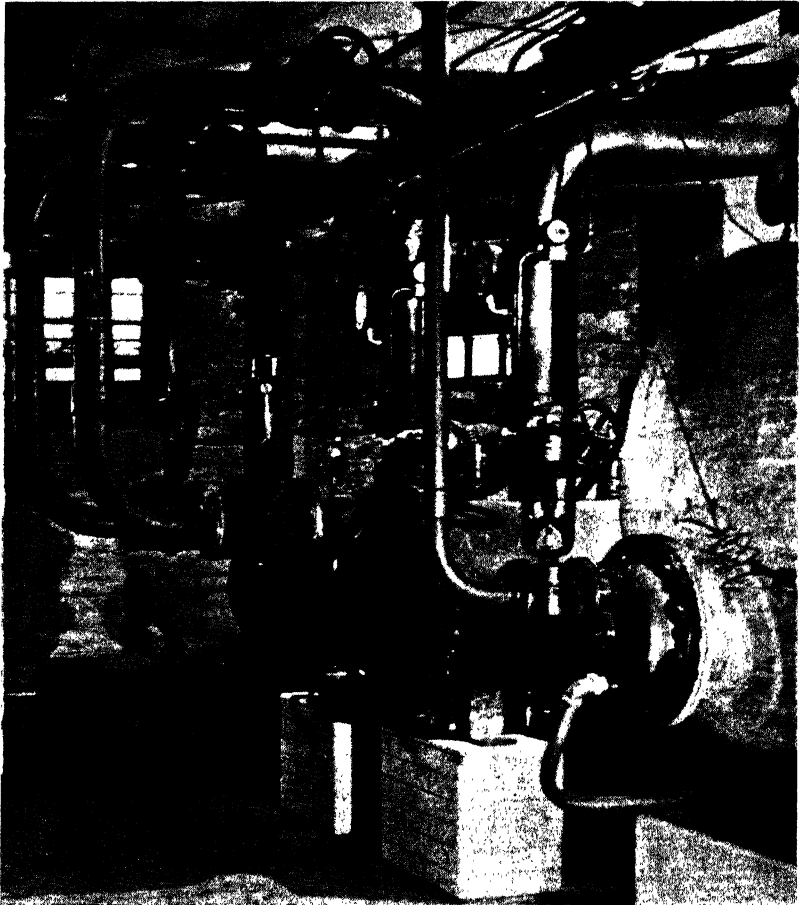

FIG. 98. HEATING AND HOT WATER STORAGE CALORIFIERS
Illustration of calorifiers, seen uninsulated, showing the brickwork supports.

Gullies and drains will also be required for the emptying of equipment in general for maintenance and repair purposes.

Calorifiers, cylinders and pumps all have to be provided with supports or bases for their erection, as have certain types of automatic stokers and oil burners. Vertical calorifiers and cylinders are generally erected upon ventilated concrete or brick bases, and those of the horizontal type are supported either on steelwork or dwarf walls

erected to carry supporting cradles as shown in Fig. 98. The installation of fans, pumps and compressors, some types of stokers, and oil burners of independent unit construction, will necessitate the provision of insulation to reduce the transmission of vibration through the building structure.

Insulating material may be either interposed between the base-plates of the machinery and its mounting base of concrete, or between

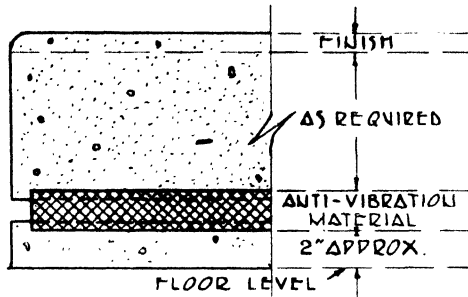

FIG. 99. INSULATED CONCRETE BASE

Details of a base insulated for the mounting of pumps, fans, and other machinery.

the latter and the floor or whatever part of the building structure it is erected upon, as shown in Fig. 99. Alternatively, anti-vibration pedestal fittings may be used. For the same reason it is necessary in certain classes of building, to insulate the air duct connections to fans by inserting flexible canvas connections, and in some instances the ducting itself by means of an internal lining of suitable material. The pipe connections to pumps may also require to be provided with non-metallic joints for the insulation of vibration. To minimize the transmission of sound it is also necessary to ensure that the speed of electric motors and other machinery is not excessive.

The installation of mechanical firing equipment for boilers using solid fuel is arranged by attachment of the necessary gear to the boiler front when the overfeed system is used. With the underfeed system the automatic stoker is positioned on the floor at the front, side or rear of the boiler as found most convenient for installation and operation. The fuel hopper comprising part of the equipment of either system of mechanical firing, when filled mechanically, entails the installation of either a self-contained independent type of fuel conveyor which is installed as a complete unit or one that is erected in sections by being secured at various points to the building structure. The actual type used will depend upon the location of the fuel bunker in relation to the boilers, and in consequence the

careful planning of fuel stores can often eliminate elaborate fuel conveyor systems. Alternatively, the bunker feed type of underfeed stoker embodies a fuel conveyor as part of its construction and may



FIG. 100A. UNDERFEED TYPE STOKER WITH DIRECT FUEL FED FROM BUNKER THROUGH TUBES SEEN ON FLOOR

(Iron Fireman)

be utilized when conditions are such that fuel at the same or higher level may be fed in a straight line from the bunker to the boilers as shown in Fig. 100A or 100B as with the hopper types.

Oil firing equipment may be installed in much the same way as mechanical stokers by the fixing of a separate unit on the floor in front of the boiler. Other types of this equipment may, however, be attached to the boiler front in part only when it is also necessary to

install an independent blower unit a convenient distance away from the boilers and connected with air ducting to the burners.

Central plant that is installed in boiler houses situated below living rooms, offices and other apartments occupied by individuals or used as storage space, will sometimes require the ceiling to be

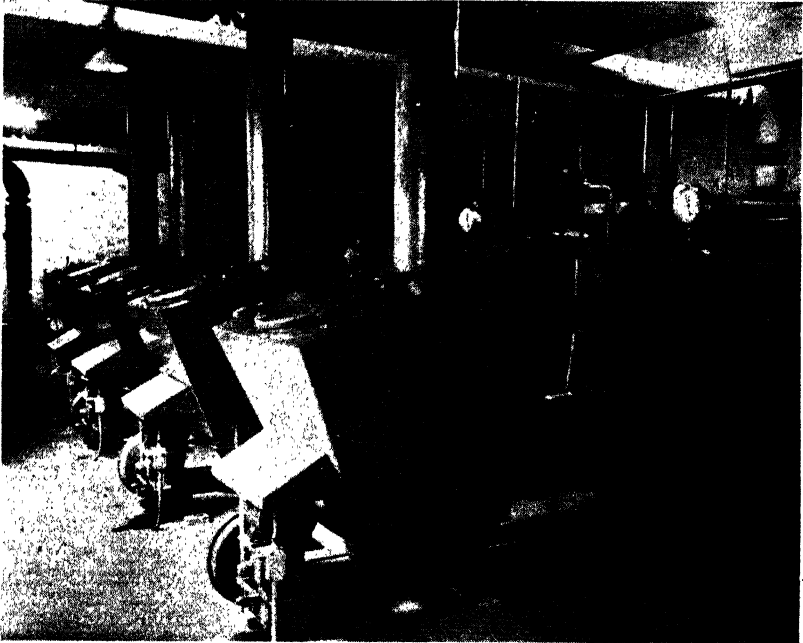

FIG. 100B. UNDERFEED TYPE STOKER WITH FUEL FED FROM OVERHEAD BUNKER
(Iron Fireman)

thermally insulated. Sound insulation¹ may also be desirable. The necessity for these provisions will depend upon both the type of plant installed and the extent of ventilation provided in the boiler house, as each of these factors affects the quantity of heat and noise transmitted to the space above. The means of dealing with thermal requirements are described in connection with thermal insulation and flues.

2. Flues and Fuel Stores. The general arrangement and constructional details of chimney stacks, and any horizontal flue connections required, must also be in conformity with both the requirements of the general scheme of planning of the building itself and the lay-out of

¹ See Appendix D.

the boiler house plant. This entails the fulfilment of certain requirements concerning thermal and moisture insulation, the heat-resisting qualities of interiors, and facilities for cleaning purposes, in addition to their being built to a specific height and internal area to comply with the requirements of boiler plant capacity.

It is important that not only the height of a flue but also its internal cross-sectional area is correct for a specific duty. Flues that are too large can be almost as defective as those too small. The internal cross-sectional form of a flue is most effective when circular. A squared section needs to be of greater area for the same efficiency, and when rectangular the length and breadth should not exceed a ratio of 3 to 2.

Bricks are still the foremost material used to-day in the construction of chimneys utilized for central heating purposes, and little change has taken place in the methods employed in their erection. An increasing range in the thermal insulative and heat-resisting properties of bricks has increased the use made of them.

Stacks that are constructed as part of the brickwork of a building should be lined throughout with insulating bricks of approved material such as moler or diatomaceous earth, in order that deterioration will not occur through expansion and contraction and to avoid excessive transmission of heat to the building's interior. A fire-brick lining will be required where flame contact will be known to occur. The walls of stacks that are exposed within the building and form part of the walling of rooms on the various floors, need to be protected in the manner suggested against the conduction of heat from the stacks interior in order to reduce the emission of heat from their surface, especially during summer time if the stack is to serve boilers for hot water supply and other services.

The arrangement of brickwork for flues in general entails the avoidance internally of sharp angles at points where changes in direction occur, not only to facilitate cleaning but to prevent a reduction in draught intensity. The jointing material between the courses should be rendered reasonably smooth and the bricks properly aligned so that ledging is avoided and no projections occur for the lodgement and excessive accumulation of soot. No obstruction should occur at the top of the stack in the form of pots or cowls, and it should terminate above adjacent structures so that adverse pressure will not be created in the stack by deflected wind currents. For cleaning purposes, a sweeping door should be positioned at a convenient height from the base of the stack and a soot removal door provided at its base.

Chimney stacks for the larger size of plant should be provided with two openings near their base for the use of testing instruments. The size of openings required in the brickwork will vary from about 1 in. to 2½ in. diameter according to whether the instruments used are of the portable or permanent type.

When firebricks are used as a lining it is usual in the larger stack, to provide an air space between this material and that of the main stack itself so that the lining may be left free to expand and contract. The more highly insulating bricks may be bonded with the main brickwork of the stack. Linings that are used with stacks serving certain gas appliances should be of fire tiles, which may have a glazed or vitreous finish, as a further precaution against the penetration of moisture. This can often be prevented, however, by the provision of a suitable air inlet near the stacks base.

To secure lightness and compactness in the construction of a stack, reinforced concrete is more suitable than brickwork. With this material linings as for brickwork are customary.

Stacks that are constructed with a cavity for insulating purposes, and utilized as an air duct for ventilating the boiler house and further decreasing thermal transmission to the building, should be constructed of good quality refractory and insulating brickwork to minimize air infiltration. The stack will require an air register in one or more of its outer walls in the boiler house, and at the top of the stack similar openings fitted with metal louvres must be provided. These should be diagonally opposed to the inlet registers in the boiler house. A typical form of construction of a brick stack indicating the openings that may be required is shown in Fig. 101.

As an alternative to the use of brickwork or concrete, the stack may be constructed of steel and housed inside the building with an intervening void between it and adjacent walling. A lining may be provided for insulation and greater permanence.

This type of stack, which is constructed in convenient cylindrical lengths for erection, may be installed with each sectional length independently supported from the building structure by fixings made to flanges provided on each length of stack, or it may be self-supported as a whole upon its base, which is arranged to rest upon a concrete foundation. This latter arrangement is one that is adopted when the stack is erected outside the building, and positioned some distance away when it will have to be provided with guy cables as a substitute for wall stays.

Steel or iron stacks are not to be recommended for use with gas

appliances owing to the corrosive action that takes place. Flues of asbestos cement or similar material must be used instead.

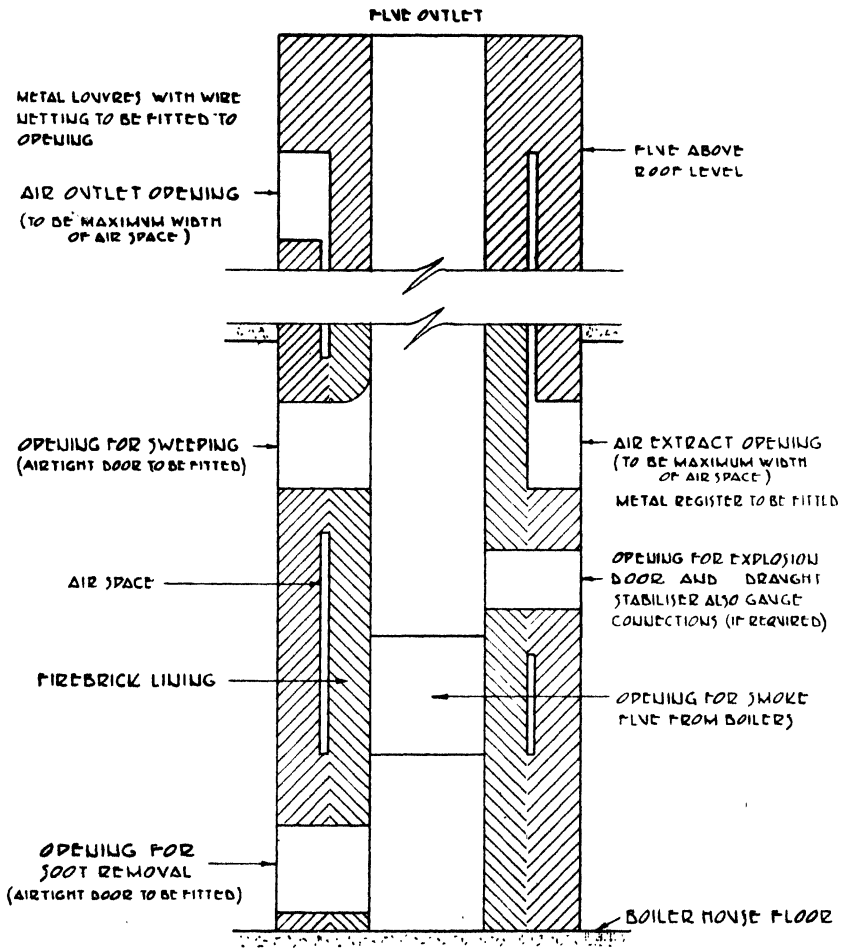

PART SECTIONAL ELEVATION OF CHIMNEY STACK

FIG. 101. RECTANGULAR BRICK SMOKE STACK

Details of openings required in brickwork for boiler plant fittings, including those necessary when stack is utilized as a ventilating shaft.

Horizontal flues that are provided to serve a battery of boilers, or as an extension to a vertical flue, may be constructed of steel or brick, each class of material being advantageous under particular conditions of planning. For example, in overhead construction,

steelwork may be considered more convenient for erection. When brick is used and the flue is built up from the floor, its top may be formed by fire tiles in preference to the more elaborate and costly arched form of construction, provided the width of flue to be spanned is not excessive. Its base should include insulating bricks if bituminous material is used for waterproofing below the flooring. The construction of underground flues should be avoided if proper facilities cannot be provided for soot removal.

Each inlet opening required in the horizontal flue for the connecting up of boiler outlets usually necessitates an isolating damper with a frame built into the brickwork. These are used to avoid impairing the draught when a battery of boilers is not fully operative and at such times as a boiler is undergoing repairs or maintenance. In addition to these fittings the usual cleaning and soot removal doors must be provided.

The fuel store is a counterpart of the boiler house and should be arranged with the object of effecting an easy transference of fuel from the store to the boiler furnaces. For this reason the bulk reserves of solid fuel should be stored, not only in a convenient position, but at a level that will enable it either to gravitate to the fuel feed hopper or combustion chamber of the boilers, or to be transferred manually from a level approximately equivalent to the boiler firing doors or hopper. Failure to fulfil these requirements means that additional mechanical or man power needs to be expended in the process of refuelling boilers.

Fuel that is to be stored for use with hand fired boilers is, therefore, more easily handled if the floor of the bunker is above the level of the boiler house floor. This difference in level will entail some loss of storage space, and to compensate for it, the fullest advantage should be taken of the bunker space to be provided. The quantity of fuel stored must not be limited to its natural angle of repose when unloaded, but increased by the provision of retaining walls carried up to ceiling level.

Boilers that are fired mechanically from hand filled fuel hoppers, require the bunker to be arranged in a similar way to that described for hand firing, if the fullest facilities are to be provided for manual filling. The height necessary for the bunker floor will vary according to the level of the hoppers, and may entail the provision of a platform in front of the bunker retaining wall. As an alternative to this arrangement for boilers in a sub-basement or basement, the fuel may be accommodated in a store positioned above the boilers, as on a

basement or mezzanine floor, so that the fuel may gravitate into the feeding hoppers. This arrangement is also recommended when the magazine type of boiler is installed, necessitating feeding fuel through the top of the boiler. Fuel that can be stored above the level of the boiler hoppers but not over them may be conveyed to the hoppers by hand-worked skips travelling on an overhead runway.

When overhead fuel storage cannot be arranged or provided

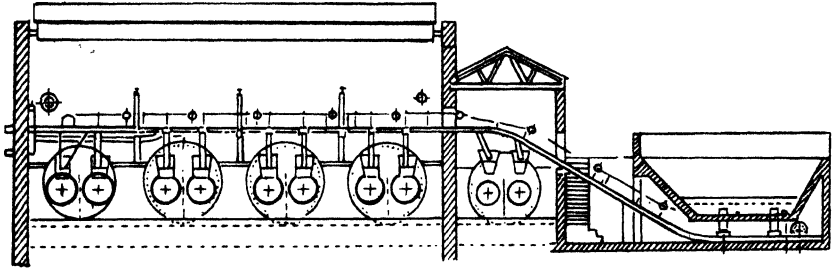

FIG. 102. COAL-HANDLING PLANT

An installation designed to feed battery of boilers by "U" link conveyor elevator delivering fuel from concrete receiving hopper direct to stoker hoppers.

(Beunis)

near hopper level, automatic fuel feed to boilers may be advantageous. This can be embodied by the use of an inclined mechanical fuel elevator supplying boiler hoppers, or the fuel may be mechanically underfed to the boiler itself. With this latter method of automatic stoking, the type of stoker used should embody extended fuel feeding mechanism as part of its equipment so that the fuel may be conveyed direct to the boiler from the fuel store.

Circumstances that necessitate the storage of fuel some distance from the boiler plant may indicate the use of mechanical conveyors as the only satisfactory means of fuel transference with the minimum of noise, dust and labour, especially when a suitable throughway cannot be provided for the passage of hand barrows. The conveyors, which may be of the belt or plated type and arranged to span passageways, and inaccessible areas, or cross over flat roofs, may be supported from wall cantilever brackets, suspended from overhead structures, or carried on steelwork supported from the ground. Fig. 102 shows a typical arrangement of coal handling plant.

The provision of storage space for the accommodation of oil fuel presents less difficulty than that of solid fuel because of the former's mobility. On this account liquid fuels may be stored in positions remote from the boiler house—which would be

inconvenient for solid fuel- and also accommodated underground should restriction of space elsewhere make this necessary. The oil may be stored in the boiler house in suitable containers, but it is preferable and usually necessary for these to be accommodated in a separate chamber. One arrangement is seen in Fig. 103.

Oil fuel may be stored in cast iron or mild steel tanks and in steel cylinders, and the use of tanks constructed of concrete rendered

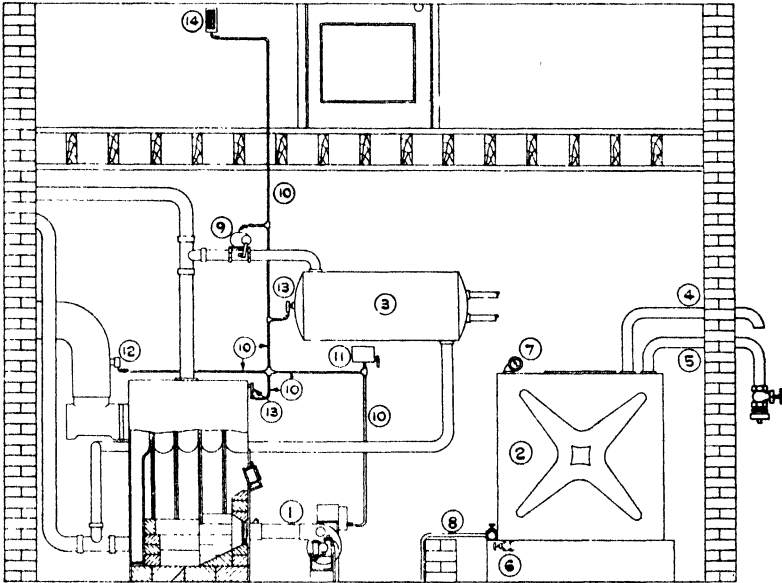

FIG. 103. OIL BURNER INSTALLATION

An arrangement suitable for a boiler serving a small combined system of central heating and domestic hot water supply.

- | | |
|-------------------------------|------------------------------------|
| 1. Automatic oil burner. | 8. Oil supply pipe. |
| 2. Oil storage tank. | 9. Motorized valve for calorifier. |
| 3. Domestic water calorifier. | 10. Electric conduit. |
| 4. Vapour pipe. | 11. Main switch. |
| 5. Oil-filling pipe. | 12. Fluestat. |
| 6. Sludge valve. | 13. Thermostat. |
| 7. Oil depth gauge. | 14. Roomstat. |

with an oil-proof finishing material may also be considered. When metal tanks are used, they may be either installed in position as a whole or erected on the site in sections by the use of plates bolted or welded together. The minimum storage capacity should be $2\frac{1}{2}$ tons.

Tanks and cylinders that are installed underground will require protection from the effects of surface and subterranean water, particularly if installed outside the building, and they should not be allowed to make contact with the soil when erected in position.

To meet these requirements it will be necessary to provide a concrete or brick chamber for the tank, or for lesser permanence it may be placed in an excavation with drainage and a filling of loose stones or gravel around the tank. The tank plates should be coated with a bitumastic solution or other suitable waterproofing material.

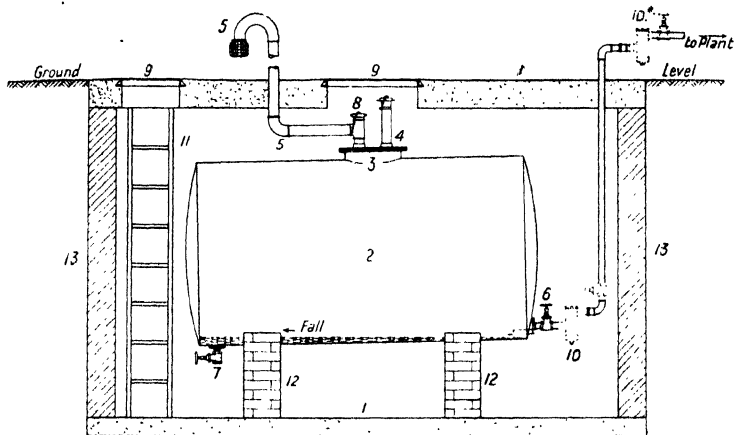

FIG. 104. UNDERGROUND STORAGE TANK

An arrangement for the storage of fuel below ground.

- | | |
|----------------------------------|---|
| 1. Concrete. | 8. Dip-pipe with cap and chain. |
| 2. Tank. | 9. Manhole cover and frame (watertight type). |
| 3. Tank manhole. | 10. Filter. |
| 4. Fill pipe with cap and chain. | 10.* Suggested alternative position for filter. |
| 5. Vent pipe. | 11. Ladder. |
| 6. Draw-off system. | 12. Brick or concrete cradles to support tank. |
| 7. Drain cock. | 13. Brick or concrete walls. |

At the top of the chamber facilities for access to the tank must be provided so that admittance to its interior may be obtained through the manhole opening. One arrangement is shown in Fig. 104.¹

The amount of space required for the storage of fuel will depend upon its class and local conditions of supply. Accommodation sufficient for not less than about three weeks' supply at normal consumption rates is desirable, and this can often be increased to gain the advantages sometimes offered by the acceptance of bulk deliveries.

¹ Reproduced by permission of the Institute of Fuel from a paper entitled "Pool Grades of Gas, Diesel and Fuel Oils, and their Efficient Utilization in Oil-burning Installations," by Messrs. Hudson, Bressy, and Bailey.

INCIDENTAL BUILDERS' WORK

1. General Requirements. The full extent of the work involved in the general installation of equipment entails the provision of certain material and labour from other trades which are outside the province of the engineering contractor so far as their actual supply is concerned, although details of the arrangement of the several items required is the responsibility of the engineer. As the work of installing the apparatus proceeds, the general contractor will therefore be required to undertake work which is categorized as "incidental builders' work" and excluded from the engineering contract.

The extent of such work, as far as it can be ascertained at the time of tendering, should be specified by the engineer, and full particulars be made available by him, after acceptance of his tender, for the builder's information. It is desirable, for instance, in order to save labour and also for the purpose of correlating the final runs to be taken up by the circuits of the apparatus with those of the sanitary, electrical and other installations, for the builder to be in possession of plans showing the approximate sizes and positions of openings that will be required in the building structure to ensure the least obstruction to the installation of apparatus, and so that the minimum of "cutting away" will be necessary.

The plans and schedule giving this information, should be made available before the commencement of the main contract, and include details of such items as plant bases, flues, air ducts, fuel bunkers, trenches, chases and fresh air inlet openings, in addition to the openings mentioned that will be necessary to pass piping and ducting through walls, floors and other structures. At the same time particulars may be given of those parts of the apparatus requiring electrical supply so that the necessary throughway for conduits may be provided. Schemes showing the proposed lay-out of apparatus should be critically examined to ascertain what these requirements may be.

Some uncertainty may arise as to what constitutes incidental builders' work. Recent progress in the construction and application of certain building materials, preformed or otherwise, which may be

regarded as alternatives to those formerly supplied as part of the engineering contract tend to make the issue obscure. The modern trend towards the concealment of apparatus within the building structure, together with the introduction of the special materials involved, has also entailed additional and more varied builders' work. It must be left to the discretion of those concerned to ensure that the alternative class of material proposed for a specific purpose in lieu of that formerly provided by the engineer is appropriate for the service it is to supply, and for agreement to be arrived at regarding who is responsible for its provision.

It is clear that other classes of material entailing erection or fixings by skilled trades must be handled by the specialist workman concerned in order that the regulations of different trade protection organizations may be observed. On this account there should be no doubt as to the exact point of termination of the work to be undertaken by the installing engineers and the commencement of that to be executed by other trades. Little change in present procedure can be made to render incidental builders' work the entire responsibility of the engineer, despite criticisms sometimes raised to the contrary, unless he employs sub-contractors.

The extent of the incidental material and labour involved to make the installation of apparatus complete, will also vary according to the type of system installed and the provision to be made for its concealment. Whatever the items necessary, allowance must be made for their provision at an early stage in the construction of a building to avoid any subsequent modifications other than those for apparatus the position of which cannot be accurately predetermined.

In addition to the different items of work to be carried out by the main contractor to enable the various parts of the apparatus to be installed, certain facilities must be provided during the progress of the work and on its completion. These include such items as stores accommodation on the site, scaffolding and ladders, artificial lighting, water supply, and electrical power for the operation of tools. Fuel, power and water must also be supplied for testing purposes.

2. Summary of Items. The particulars given in this summary, are not intended to be comprehensive and are provided only to indicate the extent of the material and labour that may be necessary in respect of the various types of apparatus installed. Not every one of the items included is necessarily entailed in any one

particular class of installation; in fact, they are in many instances alternatives.

The items of work are classified below under the respective trades where applicable—

BRICKLAYER: Vertical and horizontal flues. Bases for boilers, vertical calorifiers and cylinders. Dwarf supporting walls for horizontal calorifiers and cylinders, and for tanks, etc. Chambers for fuel storage tanks, calorifiers, pumps, fans, and air washers. Retaining and partitioning walls for fuel stores. Ducting for ventilating circuits. Trenches and chases for pipework.

CONCRETER: Bases for pumps, fans, and steel flues; bases for boilers, calorifiers, cylinders, tanks; trenches for piping and ducts for ventilating circuits when not provided in brickwork. Trenches or recesses for interposed warming panels. Raised floors, hoppers, and bunkers for fuel storage.

PAINTER: Painting of radiators, exposed warming panels, piping, ducting and thermal insulation. Clips, stays, hangers, brackets, and other engineer's metal work normally finished with paintwork.

PLUMBER: Installation of cold water supply pipes to feed and expansion tanks, storage calorifiers, cylinders and tanks, humidifiers and sterilizers, etc. Connections to bib cocks of sanitary fittings from branch pipes of hot water supply apparatus.

GAS FITTER: Installation of gas supply pipes from meter to gas-fired boilers and unit heaters.

PLASTERER: Finish over embedded warming panels in ceilings, walls, and other structures with plaster to specified requirements. Provision of ornamental fresh air inlet and extract ventilating grilles, or other approved openings in ceilings and walls.

TILER, MARBLER, AND FLOORER: Finish over interposed and embedded warming panels with tiling, marble, terrazzo, or wood blocks to specified requirements.

CARPENTER: Provision of casings and deflector shelves for radiators. Insulating casings for feed and expansion tanks. Cover panels to wall chases. Boxes and access covers to concealed regulating valves. Hardwood frames for propeller fans, ventilating grilles, louvres, and registers.

INSULATOR: Insulation of feed and expansion tanks in exposed positions, flat roofs above ceiling warming panels, inside face of external wall surfaces behind warming panels, and pitched roofs and walls when necessary.

ELECTRICIAN: Wiring up of switchgear and electrical mechanism operating fans of unit heaters and of ventilating apparatus in general, and those of forced or induced draught boilers; circulating and vacuum pumps, air compressors, and blowers; mechanical stokers, oil burners, fuel elevators and conveyors; automatic damper control gear, automatic control valves and thermostats, ozonizers, indicating and recording instruments, and air-conditioning units.

GENERAL: Formation, or cutting away and making good, of openings in walls, floors, and roofs for passage of pipes and air ducts. Cutting away for and building in supports, stays and brackets for radiators, warming panels, piping, ducting, and other sundry items of apparatus. Provision and fixing

of rebated frames and cover plates for trenches, fuel delivery hoppers and chutes, sumps, and manholes to tank chambers. Sweeping and soot doors and dampers in brick flues. External fresh air inlet registers, inlet and extract grilles, and intake and discharge ventilating louvres. Provision of store accommodation, scaffolding and ladders, and artificial lighting on site. Water, fuel, and electricity for testing and during application of plastic thermal insulation.

THE COMPLETED INSTALLATION

1. Verification of Performance. It does not, of course, necessarily follow that because an installation in a building is mechanically complete in every detail it is also functionally complete. It is, necessary to ensure that the performance and service expected from it under normal working conditions comply with specified requirements. Moreover, it is necessary to ascertain that no unforeseen factors have arisen during the course of installation to alter the required functions of the apparatus in any way.

Reference has been made to the necessity for securing a system or equipment guarantee in order to affirm the service to be provided by the installation. The guarantee will include quantitative values which may require verification by appropriate indicating or recording testing instruments. The extent of these tests, of which a brief description follows, will depend upon the performance of the system as a whole as this will determine the need for testing individual items of equipment. The investigations may entail the checking of atmospheric, gas, radiant, water or surface temperatures in addition to air velocities, pressures and humidities. It may also be necessary to check water volumes, the speed and direction of the rotation of motors, the calibration of gauges and the composition of flue gases.

Temperature tests of the air in a new building are normally made when it is dry and in occupation, and may therefore be preceded by any tests necessary to check the efficiency of circuits, radiators, air registers and other items of equipment. This latter procedure is undertaken to ensure that each section of the apparatus is capable of fulfilling its part in the provision of the final atmospheric conditions to be attained under normal working conditions of the installation as a whole.

The temperature of the air in a building that is to be warmed by the apparatus is ultimately dependent upon the quantity of heat transmitted by the space warming appliance itself, which in turn relies upon both its size and temperature, and to obtain a general indication of the latter, when water is used as a circulating medium, the temperature differential of the flow and return mains in the boiler house or of branch circuits should be noted, so that any irregularities

in this respect may be rectified by regulation. To verify individual radiator temperatures, its water temperature is taken by a thermometer, or its surface temperature indicated by a thermocouple pyrometer when steam is used. One type of instrument of this description is shown in Fig. 105.

The different air temperatures to be maintained in the various sections of a building when the outside air is at freezing point (or equivalent internal temperatures if the external temperature is above freezing point at the time of testing) should be ascertained at approximate breathing level by a mercury thermometer provided with a polished shield open at the top and bottom. The approximate determination of equivalent temperature may be effected by apparatus de-



FIG. 105. SURFACE PYROMETER
A self-contained type of pyrometer for
use on flat or curved surfaces.
(Cambridge Instrument Co., Ltd.)

signed for portable use comprising special thermometers, a flask and tripod.

The warmth provided by radiant panels may, in addition to the atmospheric temperatures recorded by an ordinary thermometer, be noted by a globe thermometer which registers the increase of temperature due to the radiant heat transmitted. Such an instrument as this also assists in ascertaining the corrected effective temperature. As a counter-check of the efficiency of radiant panels their surface temperature may also be taken by pyrometer.

The state of the atmosphere when fully conditioned must be tested in respect of its moisture content, especially if the space treated is to be used for a particular industrial process as the relative humidity then becomes important. A whirling or sling psychrometer, similar to that shown in Fig. 106, when rotated in the atmosphere will record its wet bulb depression, from which information the percentage of relative humidity can be determined. Alternatively a mechanically aspirated type of psychrometer may be used. To determine directly the percentage of relative humidity, portable instruments of the hair or electrolytic type can be used.

Rooms or buildings which have their atmosphere constantly maintained at a definite degree of warmth or humidity by automatic means may require the constancy of such conditions to be verified to ensure that the automatic controls are working satisfactorily. For this purpose a thermograph is used which continuously records on a chart the conditions maintained over a period of hours or days as required.

The amount of ventilation provided in a building according to the quantity of air delivered by fans or passing through inlet and extract registers also requires to be known in certain circumstances. This information can be obtained by the use of a vane anemometer, or velometer which, by indicating the velocity of air flow, enables the volume circulated to be computed. At the same time the temperature of the air delivered into a space should be recorded in the usual way if the quantity of heat introduced into a building in this way is to be verified. A direct reading air velocity meter is shown in Fig. 107.

To check the amount of ventilation provided in a building, the volume of air distributed by the duct circuits may be ascertained by a Pitot tube in conjunction with an inclined manometer, or for greater accuracy a micromanometer, which, by indicating the differential pressure within the ducts enables the quantity of air passing through the various circuits to be determined. A direct reading of the velocity in feet per minute may be obtained by the use of a Pitot tube and a precision differential dial gauge. The draught intensity provided by boiler flues may also be checked by a manometer or diaphragm type gauge, and if necessary the composition of flue gases examined by an analyser or CO_2 indicator and the temperature noted, to enable combustion conditions to be ascertained.

Instruments such as those described must be utilized if a true indication of the performance of the entire apparatus is to be obtained and the appropriate action taken for the rectification of faults.

2. Functional Defects. It may at first appear irrelevant to deal with the subject of functional defects in a book of this description, but if an installation is to be considered complete in every way it is necessary to ensure that the maximum service is obtained, particularly during the initial stages of operation of the apparatus. For

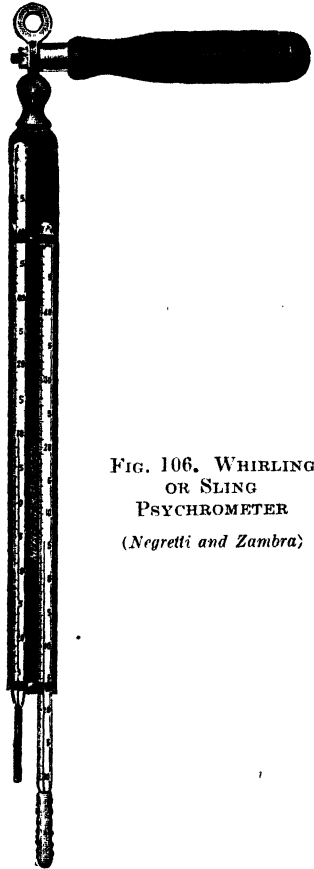

FIG. 106. WHIRLING
OR SLING
PSYCHROMETER

(Negretti and Zambra)

this purpose it is desirable to differentiate between the functional limitations of the apparatus and its actual shortcomings. Although an installation may be capable of dealing with the majority of requirements under average conditions of use, it may fail to respond to the normal maximum demands. Such failures are sometimes regarded as inherent defects of warming and ventilating installations



FIG. 107. AIR VELOCITY METER

A direct-reading type of meter shown measuring the mean air velocity at the outlet of a grille in a ventilating system by means of an averaging jet.

(*"Poole"*—*Pilot Engineers, Ltd.*)

in general, and are not recognized as faults to be avoided or overcome.

Incorrect design, defective material, inferior workmanship or faulty operation and maintenance of the plant may be responsible for failure of some part of the apparatus to give satisfactory service, and according to the nature of the fault developed, the cause may be detected. But what is of first importance to the owner of a building is not so much the cause of a suspected failure as the effect it produces so that he may be in a position to verify whether this can be regarded as normal or otherwise.

It frequently happens that building owners tolerate indifferent service from installations because it is believed that such conditions

represent the best that can be provided by an apparatus, whereas its proper functioning would give full satisfaction. For instance, the warming of a room or a section of a building may fail to reach the desired temperature at times when the weather is at freezing point, or the required temperature may only be obtained under such climatic conditions by the sacrifice of ventilation. At other times it may be found possible to provide the required temperature only by overheating the remainder of the building. In circumstances such as these the cause of insufficient warmth has been known to be attributed to the exposed aspect of this particular part of the building, due to its corner position at the top of the structure, or its abnormal subjection to winds from a particular direction. The number of windows the space possesses or its distance from the boiler house have also been claimed as legitimate causes of the defect. It should be recognized, however, that conditions such as these, although the means of disclosing the failing, are not causes but only in fact indicative of a defect in the apparatus itself.

The warming of buildings or rooms by warm air supply systems does not infer that draughts must necessarily be experienced and are inseparable from the use of such systems. Their occurrence indicates that the working of the installation is at fault due to causes that should not have arisen.

Overheating of a building is a common cause for complaint, and one that is sometimes counteracted by the supply of insufficient warmth, and either of these occurrences may signify neglect in operating the system or defective automatic controls. Sudden rises in fuel consumption may not necessarily be due to a change in the weather, but can be the result of faulty operation of the boiler plant, this cause often only being disclosed by examination of the records of the boiler house log book.

The satisfactory supply of hot water for domestic purposes, in the larger size of building, implies that it should be available at the required temperature when first opening the tap, in ample quantities for all normal purposes, and at all times throughout the day and night. Failure to fulfil any of these requirements means that the performance of the apparatus cannot be regarded as entirely satisfactory. If severe weather conditions are always followed by interruptions in the service owing to the freezing of cold water supply mains within the building, this is because of inadequate protection by thermal insulation.

The operation of an installation should not create abnormal noise or vibration due to the working of pumps, fans, firing equipment and other machinery. Its general functioning should be inaudible except within the boiler house, or plant room, except when the boilers are hand fired, when some noise must be caused by the handling of fuel. Continuity of operation of an installation should be maintained throughout the entire year, and interruptions in any of the services provided, other than those of brief duration when partial service should continue, or those due to exceptional circumstances, must be regarded as a serious failure of the plant to function in a normal manner and to comply with the standard of reliability to be expected.

Such defects as those which have been outlined are examples of the nature of the failings that may be experienced and recognized as such after a new installation is first brought into use, and which require to be rectified before the apparatus can be considered complete in every way and able to give entirely satisfactory service.

3. Avoidance of Faults. It is not to be supposed that faults of one kind and another can always be avoided by the taking of suitable precautions, as it is obviously impossible theoretically to predetermine the exact effect that will be produced under practical conditions when the normal functions of an apparatus are influenced by a combination of circumstances arising from unpredictable causes. There is, however, much that can be done to minimize the occurrence of common faults by adopting procedures that have been formulated expressly for the purpose.

Faults of a minor character generally occur with every new installation and become apparent when completion tests are carried out to verify the performance of the apparatus. These routine tests entail a certain amount of adjustment to the apparatus as a whole so that it may function in accordance with the requirements for which it was designed. Faults of this description, which should be temporary only, must not, therefore, be confused with others which may continue beyond the usual testing period and signify defects of a more serious nature, such as those already described.

The greater number of defects that arise in the working of an installation are due to improper design of the system, faulty operation of the plant, and neglect of maintenance. Failures due to inferior material or workmanship and to faulty installation of apparatus are less frequent causes for complaint. This may be attributed to the fact that it is not usually difficult to maintain a high standard in the quality of materials, and the class of workmanship employed

becomes apparent as the erection of the apparatus proceeds. Faults such as these are consequently easier to eliminate than those of design, operation, and maintenance.

Work that is undertaken as a result of keen competition for the contract is more liable to give cause for complaint and requires the rigid enforcement of an approved specification to ensure the avoidance of serious faults. If this is sufficiently comprehensive it will also do much to eliminate defects of a minor character. In the absence of such a specification it is necessary, irrespective of the circumstances under which the contract was secured, to take other precautions to reduce the risk of installing defective apparatus incurring, possibly, the imposition of penalties.

To minimize errors in general, and those arising from incorrect design in particular, it is necessary for the service to be clearly defined in the specification, together with the usual guarantees. The importance of obtaining this information becomes apparent in the event of it subsequently being deemed necessary for acceptance trials to be undertaken before final payment is made for the installation.

Should doubt exist as to the general character of the provisions to be made or uncertainty arise concerning specific details, reference may be made to publications issued by the Government, Engineering Institutions and other organizations. As a safeguard against the use of unsuitable material and defective workmanship it is desirable that this should conform with British Standard Specifications when applicable, and be covered by the usual terms of maintenance included in specifications.

To obviate as far as possible the occurrence of faults in the operating of a system by the attendant, it is advisable that particulars should be supplied concerning the methods to be adopted to ensure the satisfactory working of the various items of equipment. Details should also be given regarding the nature of the periodic inspections to be carried out for the proper maintenance of the apparatus. Failure to provide standing working instructions for the guidance of the attendant has frequently been found to be the cause for complaints of defective service from a sound installation. When installations are operated by semi-skilled attendants it may prove advisable to arrange for an annual maintenance contract, so that periodic inspections and overhauls may be made by qualified engineers to ensure that the apparatus is kept in a normal state of repair.

In conclusion, it is obviously not always possible to anticipate

the nature of the faults that may develop in connection with the mechanical treatment of the atmosphere within a building. Testing of apparatus by thermometry or other methods of testing temperature for instance, is not always a convincing means of assuring the existence of sufficient warmth, as shown by the following example of the psychological effect produced by other means in a factory building. The management of these premises was receiving from the women using the companies' canteen, complaints that it was too cold. Tests were taken, and it was found that a steady temperature of 68 deg. F. was being maintained. Eventually a colour scheme specialist was consulted who pointed out that there was a blue-green dado running around the room, and blue is a "cool" colour. The strip was repainted a bright warm orange-red and the employees thanked the management for supplying more heat!

GLOSSARY

Anemometer. An instrument for measuring the velocity of air over a period of time.

Background Heating. The maintenance of a continuous minimum temperature usually below that required for sedentary occupation.

Board of Trade Unit. See "Unit."

British Thermal Unit. A heat unit representing the quantity of heat required to raise the temperature of one pound of water one deg. F.

Calorific Value. A measure of the heat content of fuel expressed in B.Th.U.'s per pound.

Calorifier. An appliance for the transfer of heat in steam or water to water without intermixing.

CO₂. Chemical formula denoting carbon dioxide.

Conduction. The transfer of heat between two bodies in contact with each other.

Convection. The transfer of heat by the circulation of a liquid or a gas such as air.

Corrected Effective Temperature. The effective temperature with allowance for radiant heat.

Degree Day (British). The product of one day (24 hours) and 1 deg. F. difference of temperature between the base temperature and the average outside air temperature during the day when this is below the base temperature.

De-humidify. To reduce the amount of moisture in the atmosphere.

Dew Point Temperature. The temperature of air producing condensation of its vapour.

Dry Bulb Temperature. The temperature of air indicated by an ordinary thermometer.

Effective Temperature. An index of the effect produced by a combination of temperature, humidity, and air movement.

Equivalent Temperature. An index of the effect produced by a combination of temperature, radiation, and air movement.

Gauge Pressure. Pressure measured from atmospheric pressure as a datum.

Heat. A form of energy associated with matter and characterized by temperature.

Humidify. To increase the amount of moisture in the atmosphere.

Humidigraph. An instrument for recording changes in humidity.

Humidistat. A regulating instrument, actuated by humidity changes, used for automatic control purposes.

Humidity. An admixture of water vapour, and dry air.

Hygrometer. See Psychrometer.

Manometer. An instrument for measuring pressures.

Mean Radiant Temperature. The sum of the products of surface temperature and surface area surrounding a space divided by the surface area.

Micromanometer. An instrument for measuring small pressures.

Micron. A unit of measurement equal to a millionth part of a metre.

Ozone. A form of oxygen produced by electrical spark discharge, having three atoms to the molecule.

Phon. The unit of measurement of sound loudness.

Plenum. A space under pressure used as a chamber from whence air is distributed in ducts.

Psychrometer. An instrument to determine the humidity of the atmosphere.

Psychrometry. The branch of physics concerning the admixture of air and water vapour.

Radiation (Thermal.) The transfer of heat through space by wave motion.

Relative Humidity. The ratio of the actual vapour pressure in air to the vapour pressure of saturated air at the same temperature, expressed as a percentage.

Temperature. A measure of the degree of heat having no relation by itself to quantity.

Temperature Gradient. Variation in the air temperature of a heated space on a vertical or horizontal line.

Therm. A unit of heat measurement equivalent to 100,000 B.Th.U.'s.

Thermal Conductivity (K). Quantity of heat expressed in B.Th.U.'s which will pass through one square foot of material one inch in thickness in one hour for one degree difference of surface temperature.

Thermal Transmittance (U). Quantity of heat expressed in B.Th.U.'s. which will pass through one square foot of material in one hour for one degree difference of air temperature.

Thermograph. An instrument for recording changes in dry bulb temperature.

Thermostat. A heat regulating instrument, actuated by temperature changes, and used for automatic control purposes.

Topping-up Heat. The extra heat required for a comfortable temperature in a room when occupied.

Wet Bulb Depression. The difference between dry and wet bulb temperatures.

Wet Bulb Temperature. The temperature indicated by a thermometer having its bulb covered by a wet wick.

Unit (Board of Trade). An electrical unit of measurement equal to one kilowatt maintained for one hour. Equivalent in heat to 3415 B.Th.U.'s.

Velometer. An instrument for indicating the velocity of air.

Ventilation. The supply or removal of air to or from a space by natural or mechanical means.

APPENDICES

THE following appendices, to which reference is made in different parts of the text, are given so that further information may be obtained in connection with the particular subjects they concern.

- A. Heat Transmittance Coefficients.¹
- B. Air Change and Temperature Rise¹.
- C. Thermal Conductivity and Resistivity of Building Materials.¹
- D. Insulation for Impact Sound.²
- E. Atmospheric Pollution.³
- F. Fuels. Table No. 1⁴ and No. 2.²
- G. British Degree Days.²
- H. Fuel Cost Charts.⁵

¹ Reprinted in part from "Guide to Current Practice," by permission of the Institution of Heating and Ventilating Engineers.

² Reprinted by permission of The Controller of H.M. Stationery Office.

³ Reprinted from "Smokeless Air," by permission of the National Smoke Abatement Society.

⁴ Extracted from British Standard 799: "Fully Automatic Oil Burning Equipment for Central Heating and Hot Water Supply," by permission of the British Standards Institution, 28 Victoria Street, London, S.W.1, from whom official copies of the specification can be obtained, price 3s. 6d. post free.

⁵ By courtesy of the Gas Light & Coke Co.

APPENDIX A

HEAT TRANSMITTANCE COEFFICIENTS

THERMAL TRANSMITTANCE, U

B.Th.U. per sq. ft. per hr. for 1° F. difference of air temperature

WALLS

BRICKWORK---		GLASS---			
Solid, unplastered	9 in.	0.47	Single windows	1.00	
	13½ in.	0.37	Double windows	0.05	
			STONE	12 in.	0.50
				18 in.	0.40
Solid, plastered	9 in.	0.43	WOOD---		
	13½ in.	0.35	Tongued and	1 in.	0.50
Cavity, plastered	11 in.	0.30	Grooved	1½ in.	0.40
(unventilated)	15½ in.	0.26	SHEETS---		
CONCRETE			Asbestos	¼ in.	0.89
	4 in.	0.64	Corrugated asbestos	1.15
	8 in.	0.47	Corrugated iron	¼ in.	1.20

ROOFS

FLAT ROOFS---			
Asphalt on 6 in. concrete		0.57
Asphalt on 6 in. concrete, plastered		0.52
Asphalt on 6 in. concrete with 1 in. cork		0.21
Asphalt on 6 in. concrete with 1 in. cork, plastered		0.20
Asphalt on 6 in. thick hollow tile		0.48
Asphalt on 6 in. hollow tile with 1 in. cork		0.20
Asphalt, 1 in. cork, 1½ in. boards, joists, and plaster ceiling		0.16
PITCHED ROOFS---			
Corrugated asbestos		1.40
Corrugated asbestos lined ½ in. boards		0.50
Corrugated iron		1.50
Corrugated iron lined 1 in. boards and felt		0.35
Tiles on boards and felt		0.35
Tiles on battens		1.50
<i>Plaster ceiling with roof space above:</i>			
(a) With tiles and battens		0.56
(b) With tiles or slates on boards and felt		0.30
ROOF GLAZING---			
Skylight		1.20
Laylight, with lantern over		0.60

FLOORS ON GROUND

[In using the following coefficients the full temperature difference between indoors and outdoors should be taken. Allowance has been made for the fact that the underside temperature will be higher than the outdoor temperature.]

VENTILATED WOOD FLOORS ON JOISTS---		
Air-brick on one side only, bare boards	0.30
Air-bricks on more than one side, bare boards	0.40

FLOORS IN CONTACT WITH EARTH, HARDCORE, ETC.—

Concrete	0·20
Wood block floor on concrete	0·15
Granolithic on concrete	0·20
Terrazzo on concrete	0·20
Tiles on concrete	0·20

APPENDIX B

AIR CHANGE AND TEMPERATURE RISE

RATES ON WHICH HEAT-LOSS CALCULATIONS SHOULD BE BASED, WHERE
NUMBER OF OCCUPANTS CANNOT BE ASCERTAINED

*NOTE. Where mechanical warm-air inlet ventilation is usually provided
(indicated by initials W.A.I.), the rates of air change refer to the allowance
for local heating only*

ROOM OR BUILDING	AIR CHANGES PER HOUR		TEMPERATURE RISE DEG. F.
	Not more than one external wall with door or windows	More than one external wall with door or windows	
AIRCRAFT SHEDS			
Repair sheds	3	1	25
Storage sheds and hangars	3	1	15
BANKS			
Banking-hall, large (height over 14 ft.)	1½	1½	35
ditto (W.A.I.)	1	1	35
Banking-hall, small (height up to 14 ft.)	2	3	35
Offices	1½	2	35
CATHEDRALS			
Over 1,000,000 cu. ft.	1	1	30
CHAPELS AND CHURCHES			
Up to 100,000 cu. ft.	1	1	30
100,000 to 250,000 cu. ft.	3	3	30
Over 250,000 cu. ft.	1½	1½	30
¹ CINEMAS AND THEATRES . (W.A.I.)	1	1	30
COLLEGES (see Schools)			
¹ DANCE HALLS	3	3	30
ditto (W.A.I.)	1	1	30
EXHIBITION HALLS—			
Large (over 14 ft. high)	2	2	30
ditto (W.A.I.)	1	1	30
Small (up to 14 ft. high)	3	3	30
ditto (W.A.I.)	1	1	30
FLATS AND RESIDENCES—			
Living-rooms	1	1½	35
Bed-sitting rooms	1½	2	35
Bedrooms	1½	2	25
² GARAGES—			
Public	5	5	15
Private	2	2	15

ROOM OR BUILDING	AIR CHANGES PER HOUR		TEMPERATURE RISE DEG. F.
	Not more than one external wall with door or windows	More than one external wall with door or windows	
HOSPITALS—			
General Hospitals, Infirmaries, Sanatoria, and Nursing Homes:			
Wards	3	3	35
Recovery rooms	3	3	40
Dormitories:			
(bed-ridden patients)	3	3	35
(ambulant patients)	3	3	25
<i>Figures for use where a Hospital comes under the jurisdiction of the Ministry of Health.</i>			
Wards		3	30
Dormitories		3	30
HOTELS—			
¹ Public rooms	3	3	35
ditto (W.A.I.)	1	1	35
Dining-rooms	3	3	35
ditto (W.A.I.)	1	1	35
¹ Ballrooms	2	2	35
ditto (W.A.I.)	1	1	35
Bedrooms	1	1½	30
Bed-sitting rooms	1	1½	35
Sitting-rooms	1½	2	35
LIBRARIES—			
Reading rooms (up to 14 ft. high)	2	2	35
ditto (over 14 ft. high)	1½	1½	35
Stack spaces	1	1½	30
OFFICES—			
General offices	1½	2	35
Private offices	1½	2	35
Typists' offices	2	2	35
PUBLIC-HOUSES .			
Bars	3	3	30
Dining-room	2	2	30
RESTAURANTS—			
Dining-rooms	3	3	30
ditto (W.A.I.)	1	1	30
Tea-shops	4	4	30
ditto (W.A.I.)	1	1	30
SCHOOLS AND COLLEGES—			
Classrooms (ordinary)	3	3	30
CLASSROOMS ("Semi open-air")	5	5	30
Assembly halls	1	1½	25
Common rooms	2	2	35
Dormitories	2	2	25

266 HEATING AND AIR CONDITIONING EQUIPMENT FOR BUILDINGS

ROOM OR BUILDING	AIR CHANGES PER HOUR		TEMPERATURE RISE DEG. F.
	Not more than one external wall with door or windows	More than one external wall with door or windows	
SHOPS AND SHOWROOMS—			
Small	3	3	30
Large	2	2	30
Large departmental spaces (W.A.I.)	1	1	30
¹ SWIMMING BATHS—			
Large (over 14 ft. high)	1½	1½	40
Small (up to 14 ft. high)	3	3	40
¹ THEATRES AND CINEMAS . (W.A.I.).	1	1	30

¹ Subject to requirements of local authorities where licensed as a place of public entertainment.

² May be subject to local regulations where below street level and for exceeding defined capacity.

APPENDIX C

THERMAL CONDUCTIVITY AND RESISTIVITY OF BUILDING MATERIALS

AT NORMAL ATMOSPHERIC TEMPERATURES

<i>Material</i>	Conductivity k B.Th.U. per sq. ft. per hour per ° F. diff. per inch thickness	Resistivity $\frac{1}{k}$ Degrees F. per inch thickness for 1 B.Th.U. per sq. ft. per hr.
ASBESTOS CEMENT SHEETING	1.9	0.527
ASPHALT	8.7	0.115
BITUMEN	1.1	0.91
BRICKS—		
Common, moisture content 0 %	5.6	0.18
" " " 9.0%	9.9	0.10
Diatomaceous, moisture content 0 %	0.99	1.01
" " " 75.0%	3.1	0.32
CONCRETE—		
Ballast concrete:		
1 : 1 : 2	6.7	0.15
1 : 2 : 4	7.0	0.14
Clinker concrete:		
Light	2.3	0.44
Heavy	2.8	0.36
Foamed-slag concrete:		
1 : 2½ : 7½, moisture content 0 %	1.5	0.67
" " " 5.3%	1.9	0.53
Pumice concrete:		
1 : 2½ : 7½ " " 0 %	1.1	0.91
" " " 8.6%	1.8	0.56
GLASS	7.3	0.137
GRANOLITHIC	6	0.17
LINOLEUM—		
Battleship	1.26	0.79
Inlaid	1.62	0.62
MARBLE	17.4	0.06
PLASTERING—		
Sand and cement	3.7	0.27
Lime, sand, and cement	3.3	0.30
SAND	4	0.25

268 HEATING AND AIR CONDITIONING EQUIPMENT FOR BUILDINGS

<i>Material</i>	<i>Conductivity</i> $\frac{k}{}$ B.Th.U. per sq. ft. per hour per ° F. diff. per inch thickness	<i>Resistivity</i> $\frac{1}{k}$ Degrees F. per inch thickness for 1 B.Th.U. per sq. ft. per hr.
SLATE	10.4	0.096
STONE—		
Granite	20.3	0.049
Limestone	10.6	0.094
Sandstone	9	0.11
TERRAZZO	11	0.091
THATCH	0.77	1.30
TILES—		
Burnt clay	5.8	0.17
Concrete	6.5	0.15
TIMBER—		
Balsa wood	0.33	3.03
Deal	0.87	1.15
Oak	1.11	0.90
Mahogany	1.08	0.93
Plywood	0.96	1.04
Walnut	0.96	1.04
WALLBOARD—		
Fibre board	0.38	2.63
Plaster board	1.1	0.91

APPENDIX D

AVERAGE INSULATION FOR IMPACT SOUND CONCRETE FLOORS

	<i>Noise Reduction Phons</i>
Bare concrete	0
Carpets, etc.—	
$\frac{1}{2}$ -in. lino, and $\frac{1}{2}$ -in. lino on roofing felt	5
Wood blocks, thin carpet, rubber	5-10
$\frac{1}{2}$ -in. carpet on $\frac{1}{2}$ -in. underfelt, $\frac{1}{2}$ -in. hard rubber-cork compo.	10
$\frac{1}{8}$ -in. sheet rubber on $\frac{1}{2}$ -in. sponge rubber	20
Screeds, 2-in. thick, on following underlays—	
Clinker	5-10
Granulated cork, 1-in.	10-15
Slag-wool quilt, or eelgrass quilt	15-20
Glass silk quilt, single layer, or eelgrass quilt, double layer	20
Glass silk quilt, double layer	25
Boarding on battens on following underlays—	
Clips	5-10
Asbestos pads or felt pads, $\frac{1}{2}$ -in. thick	5-10
Fibre board pads, $\frac{1}{2}$ -in. thick	10
Felt pads 1-in. thick, or rubber pads $\frac{1}{2}$ -in. thick	10-15
Eelgrass quilt, or slag-wool quilt, $\frac{1}{2}$ -in. thick	10-20
Glass silk quilt or rubber pads, 1-in. thick	15-20
Suspended ceilings—	
$\frac{1}{2}$ -in. plaster on $\frac{1}{2}$ -in. fibre board on 2-in. \times 2-in. battens in clips	5-10
$\frac{3}{4}$ -in. plaster on $\frac{3}{4}$ -in. plaster board on battens in felt-lined clips	10-15
<p>No figures are available for metal lath ceiling suspended on metal supports, but their performance appears to be of the same order as the above.</p>	

TIMBER FLOORS

<i>Treatment</i>	<i>Noise Reduction Phons</i>
Normal board and joist floor, lath and plaster ceiling	0
Carpet on underfelt	10
Plaster on plaster board ceiling	0
Pugging, sand, or ashes 10 lb. per sq. ft., or slag wool 2 lb. per sq. ft.	5
Sand or ashes 20 lb. per sq. ft.	10
Floor boards on cross battens on glass silk quilt, not nailed	5
Floor boards on glass silk quilt, on sub-boarding	10
Floor boards on fibre board, on sub-boarding.	5
Separate joists to carry ceiling	5

APPENDIX E

ATMOSPHERIC POLLUTION DEPOSITS

	TOTAL SOLIDS			TOTAL SOLIDS	
	Mean monthly deposit (tons/sq. mile)	Percentage of general average		Mean monthly deposit (tons/sq. mile)	Percentage of general average
<i>Birmingham</i> —			<i>Leeds (contd.)</i>		
West Heath	17	156	Park Square	31	111
<i>Bournville</i> —			Templenessam	11	131
Village	10	110	York Road	23	88
Works	13	113	<i>Leicester</i> —		
<i>Bradford</i> —			Humberstone	11	87
Central	22	70	Town Hall	23	79
North	17	144	<i>Liverpool</i> —		
<i>Bristol</i> —			Aighruth Vale	15	118
Waterworks	23	—	Cambridge Street	29	111
Zoological Gardens	10	—	St. George's Hall	29	105
<i>Burnley</i> —			<i>Loggerheads</i>	5	—
Bank Hall Hospital	26	121	<i>London</i> —		
Marsden Road San.	19	—	Archbishop's Park	19	76
Town Hall	32	—	Battersea Park	18	—
<i>Cardiff</i> —			Finsbury Park	17	78
Whitley	15	99	Golden Lane	22	63
<i>Coventry</i> —			Horseferry Road	30	103
Edgwick	19	—	Kew Observatory, N	9	93
Greyfriars Green	19	—	Kew Observatory, S.	9	77
Whitley	12	—	Mount Street	22	91
<i>Dagenham</i>	21	—	Ravenscourt Park	14	51
<i>Dewsbury</i> —			S. Kensington (M.O.)	20	96
Municipal Buildings	23	—	Southwark Park	21	88
Ravensthorpe	22	110	Victoria Park	17	97
Whitley	13	124	Wandsw'th Common	12	76
<i>Edinburgh</i> —			Westminster—		
Astley Ainslie Inst.	11	—	King Charles St.	21	91
Glencorse	7	—	<i>Loughborough</i> —		
Leith Links	14	94	No. 1 Gauge	10	41
St. Andrew's Square	21	—	No. 2 Gauge	9	—
<i>Garston (Herts)</i>	9	75	<i>Lymm</i>	12	—
<i>Glasgow</i> —			<i>Manchester</i> —		
Glasaholle	10	—	Baguley	11	—
Glasgow Cross	23	90	Booth Hall	15	—
Queen's Park	16	93	Heaton Park	12	—
Ruchill Park	18	89	Phillips Park	41	—
Victoria Park	15	56	Rusholme	26	—
<i>Gloucester</i>	11	71	Withington	13	—
<i>Godalming</i>	6	—	<i>Marple</i>	13	66
<i>Greenhithe</i>	52	—	<i>Margate</i>	9	—
<i>Grimsby</i>	16	—	<i>Marsden</i>	17	—
<i>Halifax</i> —			<i>Newcastle-upon-Tyne</i> —		
Akroyd Park	19	147	Town Moor	13	62
Belle Vue Park	16	122	Welbeck Res.	17	84
Infrmary	14	126	Westgate Cem.	17	52
Wade Street	30	124	<i>Oley</i>	18	—
West View Park	12	104	<i>Rothamsted</i>	6	62
<i>Hove</i>	45	—	<i>Rotherham</i> —		
<i>Huddersfield</i> —			Oakwood Hall San.	15	121
Cooper Bridge	10	35	Technical College	22	84
Deighton	22	65	<i>St. Helens</i>	28	74
<i>Keighley</i> —			<i>Salford</i> —		
Morton Cemetery	11	—	Drinkwater Park	21	132
<i>Kingston-upon-Hull</i> —			Ladywell San.	21	87
Central	23	79	Peel Park	20	63
Country	9	—	<i>Scunthorpe</i> —		
Suburban	9	—	Britannia Corner	23	—
<i>Leeds</i> —			Isolation Hospital	19	—
Headingley	12	103	Santon	174	—
Hunslet	21	76			

	TOTAL SOLIDS			TOTAL SOLIDS	
	Mean monthly deposit (tons/sq. mile)	Percentage of general average		Mean monthly deposit (tons/sq. mile)	Percentage of general average
<i>Sheffield</i> —			<i>Stoke-on-Trent</i> —		
Attercliffe	31	123	Leek Road	18	99
Dore	8	—	Longton	26	105
Ewden Waterworks	10	—	Tunstall	18	—
Nether Green	9	98	<i>Wakefield</i> —		
Stocksbridge	19	100	Clarence Park	9	79
Surrey Street	25	77	<i>Wallsend</i>	13	82
<i>Shipley</i> (Yorks)	15	89	<i>Walsall</i>	15	143
<i>Skipton</i>	15	—	<i>Widnes</i> —		
<i>Southampton</i>	22	155	Isolation Hospital	22	—
<i>Southport</i> —			Moor Lane	43	—
Bedford Road Park	16	151	<i>Wolverhampton</i> —		
Hesketh Park	10	84	Public Abattoir	23	—
			West Park	12	—

SUSPENDED IMPURITIES

	Suspended Impurity Average for Year (mgm./m. ³)	Percentage of Z days during winter months
South Kensington	0.21	9
Victoria Street, S.W.1	—	34
Westminster Bridge	0.33	11
Cardiff	0.06	0
Coventry	0.25	1
Edinburgh	0.51	31
Greenwich	0.70	56
Kew Observatory	0.08	4
Kingston-upon-Hull	0.34	24
Stoke-on-Trent	0.59	45
Glasgow (average of 5 stations)	—	8

[A "Z" day is one of thick smoke haze, and is recorded as such when the suspended impurity exceeds a concentration of 1.28 milligram per cubic metre.]

APPENDIX F

TABLE I
PETROLEUM FUEL OILS FOR DOMESTIC OIL BURNING EQUIPMENT
(Extract from B.S. 742 Fuel Oils for Burners (Petroleum and Shale Oils)
including Methods of Test)

	A	B
	Without Pre-heaters	With Pre-heaters
Flash Point (closed)	Min. 150° F.	Min. 150° F.
Viscosity (Redwood No. 1) at 100° F.	Max. 45 secs.	Max. 250 secs.
Water Content	Max. 0.25%	Max. 0.75%
Conradson Carbon	Max. 0.2%	—
Gross Calorific Value B.Th.U./lb.	Min. 19 000	Min. 18 500
Pour Point	Max. 30° F.	Max. 40° F.*
Sulphur Content	Max. 2%	Max. 3%
Ash Content	Max. 0.01%	Max. 0.1%

* These limits are intended for temperate climates only. In any case, the purchaser shall satisfy himself that his whole equipment is capable of dealing with the oil at the lowest temperature to which the oil will be exposed.

TABLE II
FUEL SIZES AND DESIRABLE ASH CONTENT

	Fuels	Open Fires (a) New Type	Space- heating Stoves	Cooking, and Water- heating Appliances (Closed Fire)	Cooking, Water- heating and Space- heating Appliances (Openable Fire)	Independ- ent Boilers
Fuel sizes	Coals . . .	1-5 in.	1-3 in. (b)	1-2 in.	1-3 in.	
	Anthracite . .	1-3 in.	$\frac{3}{4}$ -1 $\frac{1}{4}$ in. (c)	$\frac{3}{4}$ -1 $\frac{1}{4}$ in. (d)	1-2 in.	$\frac{3}{4}$ -1 $\frac{1}{2}$ in. (1-2 in.)
	Briquetted fuels and L.T. coke } . .	1-3 in.	—	$\left(\frac{1}{2}-1\frac{1}{4}\right.$ in. $\left.1-2\right.$ in.	$\left(\frac{1}{2}-1\frac{1}{4}\right.$ in. $\left.1-2\right.$ in.	$\frac{1}{2}$ -1 $\frac{1}{4}$ in.
	Coke . . .	1-2 in.	$\left(\frac{1}{2}-1\frac{1}{4}\right.$ in. $\left.1-2\right.$ in.	$\left(\frac{1}{2}-1\frac{1}{4}\right.$ in. $\left.1-2\right.$ in.	$\left(\frac{1}{2}-1\frac{1}{4}\right.$ in. $\left.1-2\right.$ in.	$\frac{1}{2}$ -1 $\frac{1}{4}$ in.
Desirable ash content	Coals not to exceed } . . .	6%	6%	6%	6%	—
	Anthracite not to exceed } . . .	5% (e)	5%	5%	5%	5%
	Coke not to exceed } . . .	6% (e)	6%	6%	6%	6%

(a) Large unbroken coal will continue to be available for the existing types of open fire.

(b) Only recommended if smoke-reduction arrangements are provided.

(c) Smaller quantities of $\frac{1}{2}$ in.- $\frac{3}{4}$ in. and $\frac{3}{8}$ in.- $\frac{3}{4}$ in. also required.

(d) Smaller quantities of $\frac{3}{8}$ in.- $\frac{3}{4}$ in. also required.

(e) For coke and briquetted fuels, the ash should be as dense and coarse as possible.

APPENDIX G

BRITISH DEGREE DAYS TO A BASE TEMPERATURE OF 60 DEG. F.
(AFTER DUFTON)

Degree days, which may be used to determine the quantity of heat required in a building, vary according to locality, as shown on the map below giving annual totals.

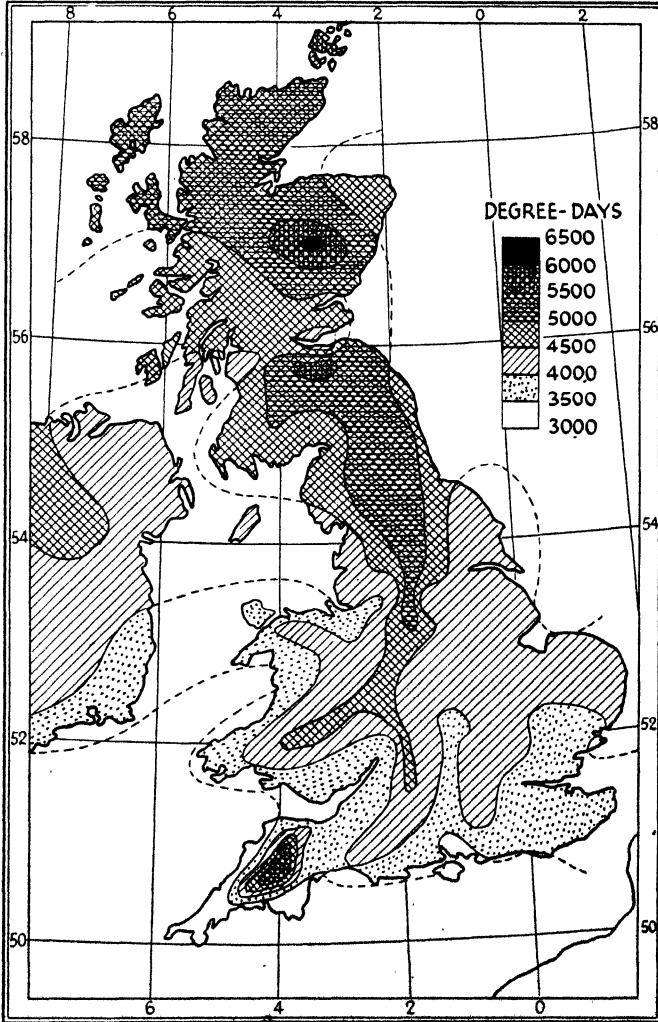

APPENDIX H

FUEL COST CHARTS

(For explanation of use, see page 277)

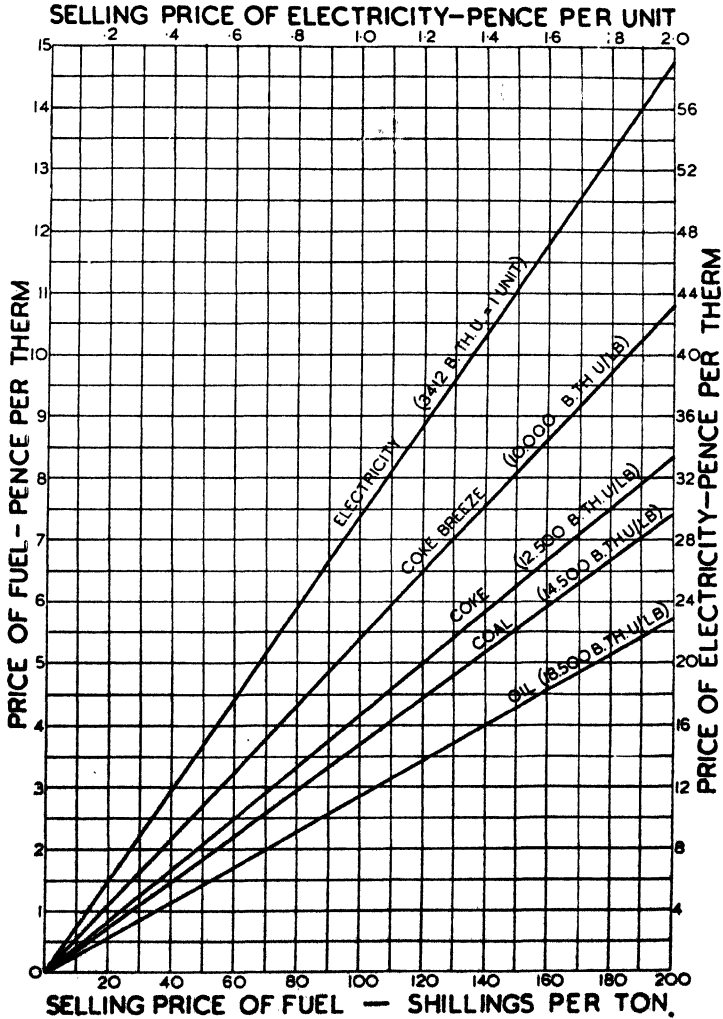
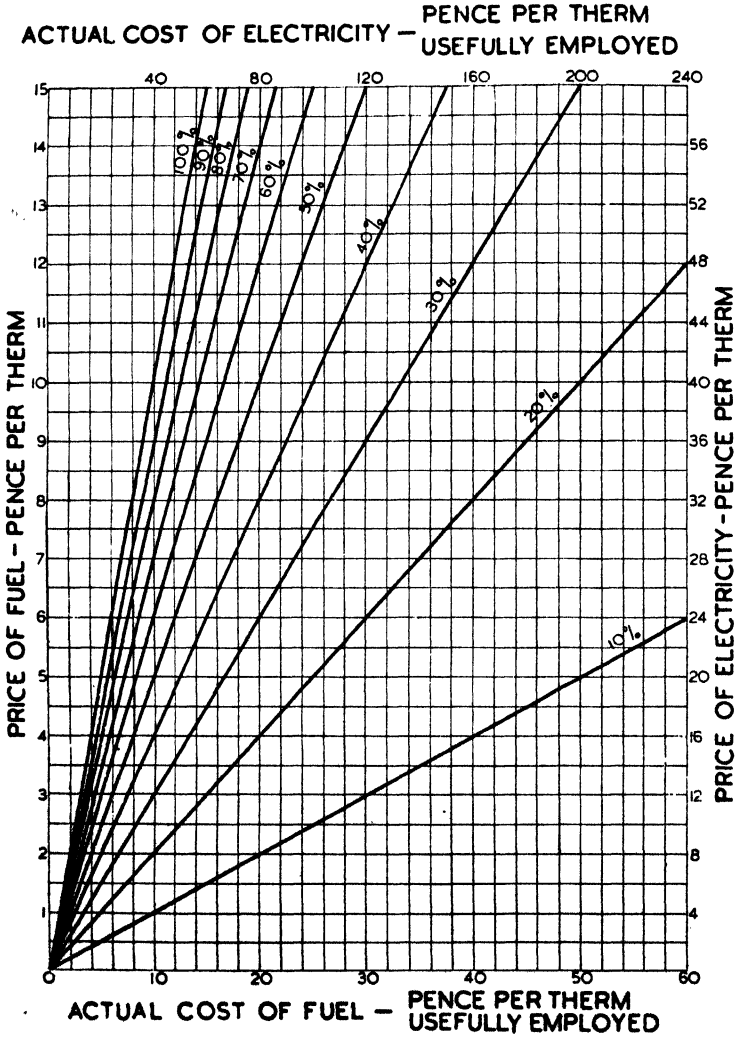

CHART I.



(For explanation of use, see next page)

Chart I indicates the price per therm of various fuels in terms of the price per ton, or, in the case of electricity, of the price per unit.

The top and right-hand scales apply to electricity, whilst for all other fuels in the chart the bottom and left-hand scales are used. Efficiency of usage is taken at 100 per cent in all cases.

[*Note.* 1 therm = 100,000 B.Th.U.'s.]

Example A.

What is the price per therm of oil, the selling price of which is 120s. per ton?

Move up the vertical line at 120 in the bottom scale until the "Oil" line is reached. Move *left* along the horizontal line, and the answer is given on the left-hand scale, i.e. 3·5d.

Example B.

Electricity is sold at 0·4d. per unit; what is the equivalent price in pence per therm?

Start at 0·4 on the top scale and move *down* the vertical line until the line marked "Electricity" is reached. Move *right* along the horizontal line and read off the answer on the right-hand scale. The price is 12d. per therm.

Chart II is used in conjunction with Chart I, from which the price per therm of various fuels may be obtained.

The efficiency lines on this chart are efficiencies of usage.

The top and right-hand scales apply to electricity only, whilst the bottom and left-hand scales apply to all other fuels. Electricity costs are quoted as pence per therm for ease of comparison with those of other fuels.

Example.

Taking the example given in connection with Chart I, what is the actual cost of fuel in pence per therm usefully employed, the efficiency of usage being 60 per cent (70 per cent boiler efficiency and 85 per cent internal transmission efficiency)?

Move to the right along the horizontal "3·5 pence" line (left-hand scale) to the 60 per cent line. Move down vertically to the bottom scale. The answer is 6d.

TEMPERATURE CONTROLS



We are manufacturers of a very wide range of temperature control devices, and we shall be pleased to send you details of instruments which you may require for a particular application, and to submit control schemes to fulfil a given purpose.

As you know, it is only by applying automatic temperature control to a heating scheme that maximum efficiency and reasonable comfort can be attained.

The necessary balance between heat input and the heat requirement can be satisfied only if careful attention is paid to the control of temperature; so many variables tend to upset this balance that it cannot be maintained other than by automatic means.

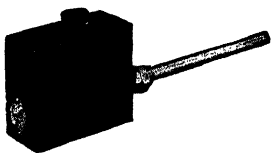

One of the devices which we manufacture is the "Compensator 4," which is designed to control the temperature of the heating flow water in accordance with the prevailing weather conditions. This instrument can be applied to automatic boiler firing plants, for instance, oil burners, coal stokers, gas burners, etc., and to the control of steam to water calorifiers.

Motorized Valves for steam and water are made for control by room thermostat or immersion thermostat according to the requirement.



Complete control equipment for automatic oil burners and coal stokers, etc., is made, and used by all the leading firing equipment manufacturers.

We have Engineers in all parts of the country who are anxious to advise on any temperature control problem which may arise, and if you would like one of these Engineers to call to see you, please write to us and we shall be pleased to make the necessary arrangements.

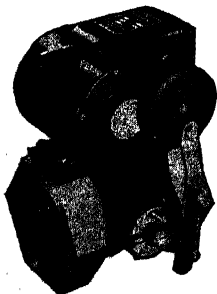

The
RHEOSTATIC CO. LTD
SLOUGH ENGLAND

Telephone:- Slough 23311-6
Grams:- Resistance · Slough

INDEX

- ACCELERATORS, 58, 217
Activated alumina, 87
Adjustable registers, 79
Adsorbers, 87
"Airchange," 17, 18, 29, 71, 263
Air circuits, 65
— cleaners, 76, 226
— cleanliness, 29
— conditions, 8
— cooler, 84
— cooling, 82, 83
— ducts, 67, 222, 223
— excess, 136
— fully conditioned, 11, 33, 66
— heaters, 77, 226
— inlets, 30, 74, 79, 206
— locks, 35
— recirculation, 65, 88
— registers, 79
— systems, 34, 64, 65
— temperature, 8, 13
— thermostats, 121, 258
— velocity, 8
— volume, 17, 29
— washers, 77, 88, 90
Airing coils, 38, 169
Analysis, air, 16
— fuel, 129
— gas, 116, 135
— water, 163
Anemometer, 251, 257
Anthracite, 132
Anti-vibration, 221, 235
Appliances, classification of, 37, 171
—, air conditioning, 81
—, automatic control, 122
—, central, 37
—, electrical, 172, 186, 187, 189
—, frontal areas, 37
—, gas, 172, 180
—, local, 171
—, oil, 109, 243
—, solid fuel, 100, 109, 171, 174
Aspect control, 124
Atmospheric pollution, 270
Automatic control, 117

BACKGROUND heating, 22, 154, 257
Balanced ventilation, 66
Bases, 234
Bituminous coal, 132
Blowdown pits, 233
Board of Trade Unit, 257
Boiler efficiency, 113, 133
— firing methods, 106
— gravity feed, 101
Boiler house, 93, 232
—, sectional, 100
— shell, 101
— temperature control, 120, 122, 124
—, types, 100
Boilers, classification of, 100
Brick chimneys, 238
British Thermal Unit, 257
B.T.U. meter, 113
Builder's work, 95, 233, 245
Bunker stoker, 110
Burners, gas, 106
—, oil, 109

CALCIUM chloride, 87
Calorific value, 133, 173, 257
Calorifiers, 88, 165, 234, 257
Ceiling warming, 48, 52, 214
Centralized control, 122
Change, air (see Air change)
Chimneys, 71, 93, 95, 237
Circuits, heating, 59, 62, 65
Circulating pressure, 58
— systems, 55
Circulation, forced, 60, 217
—, gravity, 58
Cleaners, air, 76, 226
Cleanliness, of air, 29
Closeable fireplace, 175
— stoves, 179
Coal, 131
— fire, 174
Coefficients, 261
Coke, 132
Coke grate, 176
Coking stoker, 109
CO₂ flue gases, 135
— indicator, 116, 251
Coils, 38
Column radiators, 43
Combination appliances, 177
Combined generating stations, 152
— systems, 31, 78, 81, 164
Combustion conditions, 114, 134
Comfort chart, 9
Complete conditioning, 87
Concrete chimneys, 239
Condensation, on apparatus, 83
—, in flues, 239
—, on glass, 38, 146
—, on walls, 15, 140
Conditioning apparatus, 87
— units, 90, 231
Conduction, 257
Conductivity, 142, 258, 267
Connections to radiators, 208

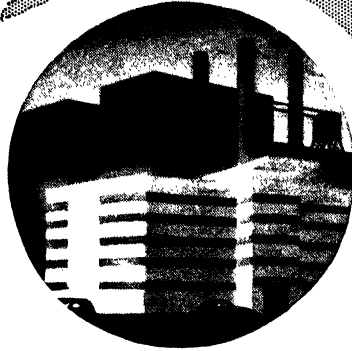

Automatic Stoking

can increase the combustion efficiency of almost every type of steam or hot-water boiler ; it gives excellent results from low-grade fuel ; it takes care of fluctuating demands on the boiler (it gives good service year after year, after paying for itself out of savings as it often does, within the first two or three years).

RILEY ROBOT STOKER

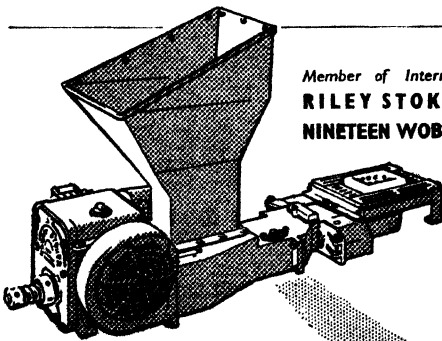

Member of International Combustion Organisation
RILEY STOKER COMPANY LIMITED
NINETEEN WOBURN PLACE LONDON, W.C.1



Write for details of automatic stokers for firing metallurgical furnaces, brick kilns, Economic Lancashire and Water-tube boilers.



- Contract variation, 201
 Controller, climate, 124
 Controls, 117, 124
 Convection heating, 26
 Convector heaters, 41, 172, 189
 ----- radiators, 42, 183, 210
 Conveyors, fuel, 236, 242
 Cooler unit, 184, 229
 Cooling, 82, 83
 Cornish boiler, 101
 Corrected effective temperature, 257
 Corrosion, 163, 165, 166
 Costs, fuel, 133, 173, 275
 -----, installation, 5, 26, 49
 Cylinders, 165, 234, 243
- DAMPERS, 224, 241**
 Defects, functional, 251
 Degree days, 257, 274
 De-humidification, 85, 229
 De-humidifiers, 86, 229
 De-humidify, 257
 Deposits, moisture, 15, 83, 140, 239
 -----, scale, 100, 136, 165
 -----, soot, 136, 238, 270
 Descaling, 100, 165
 Dew point temperature, 257
 Diatomaceous earth, 143, 238
 Diffuser, 225
 Direct systems, 163
 Discharge from taps, 167
 District heating, 152
 Down draughts, 27, 38, 43
 Draught chimney, 70, 116
 ----- gauge, 116
 -----, mechanical, 95, 109
 Draughts, 30, 69, 70, 179
 Dry bulb temperature, 257
 Drying racks, 169
 ----- rooms, 11, 204
 Ducts, air, 67, 222, 223
 -----, encased, 223
- ECONOMY, fuel, 134**
 -----, heat, 118, 136, 139
 Economic boilers, 103
 Effective temperature, 8, 257
 Efficiency of boilers, 113, 133
 ----- heaters, 173
 Electric convector heaters, 189
 ----- fires, 187
 ----- hot water heaters, 190
 ----- radiators, 189
 ----- thermal storage, 98
 Electrical appliances, 172, 186
 Electricity, 130
 Electrostatic precipitation, 77
 Elevators, fuel, 236, 242
 Embedded panel, 52, 215
 Emergency equipment, 99
 Emission, heat, 43, 211
 Encased heaters, 41, 190, 207
- Equalized travel circuit, 59
 Equivalent temperature, 8, 257
 Evaporative cooling, 82
 Excess air, 136
 ----- temperature, 118
 Exhaust steam, 61
 Expansion, 203, 218, 220
 Exposed ducting, 222
 ----- insulation, 150
 Extract ventilation, 70
- FANS, 73, 79, 227**
 Feed tanks, 164
 ----- water meter, 113
 Filters, air, 76
 Firebrick lining, 239
 Fireplaces, 174
 Fires, electric, 187
 -----, gas, 181
 -----, solid fuel, 174
 Firing equipment, 106
 Floor insulation, 145
 ----- plates, 220
 ----- warming, 48, 50, 65, 214
 Flue gases, 135
 ----- ventilation, 68, 71, 239
 Flueless gas heaters, 180, 184
 Flues, 71, 93, 237, 239
 Forced draught, 95, 109
 ----- circulation, 60, 217
 Fresh air, 16, 68, 74
 ----- air inlets, 74, 79, 206
 Fuel conveyors, 236, 242
 ----- costs, 133, 173, 275
 ----- economy, 134
 ----- meter, 113
 ----- oil firing, 106, 236
 ----- storage, 95, 243
 ----- stores, 93, 241
 Fuels, 127, 273
 -----, classification of, 130
 Fully conditioned air, 11, 33, 66
 Functional defects, 251
 Furring, 166
- GAS, 131**
 ----- appliances, 172, 180
 ----- fires, 181
 ----- firing, 106
 ----- flue, 116, 135
 ----- heaters, 40, 182, 185
 ----- radiators, 183
 Gauge, draught, 116
 ----- pressure, 257
 Globe thermometer, 250
 Grates, 176
 Gravity, circulation, 58, 217
 ----- feed boiler, 101
 Grilles, 79, 224, 225
- HAND firing, 106**
 Health, conditions for, 7, 156

Power Operated
VENTILATING SHUTTERS

for instant clearance of
FUMES AND SMOKE
from Foundries, Retort Houses, Furnace Buildings, etc.

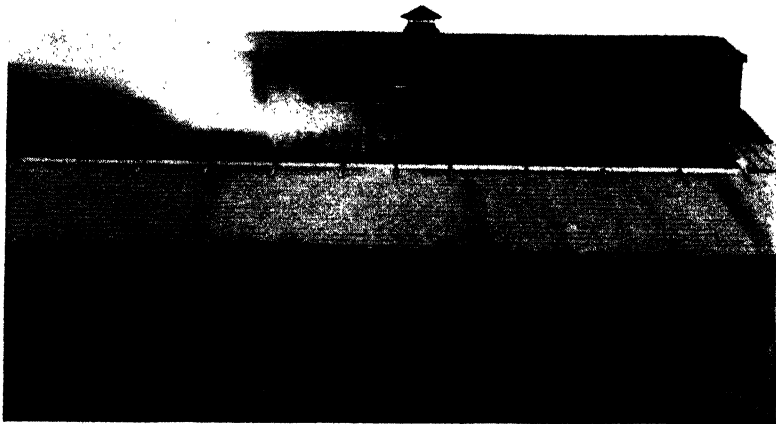

*Photograph by courtesy of the City of Salford Gas Dept.
(D. V. Lewis, Esq., M.Inst.Gas E., Eng. & Manager).*

The Shutters provide what is in effect a movable roof to the building which, by means of steel louvres in themselves forming extraction vanes, create extraction draught. The louvres are formed on both sides of a centrally operated dual gear unit; each side can be operated independently in

order to facilitate extraction in strong winds. In very wet weather, driving snow and at night they can be closed and form complete weather-tightness.

Adequate natural light to the workshops below is available when the shutters are open.

BRITISH PATENT NOS. 536127, 536942, AND 536943

HILLS

HILLS PATENT GLAZING CO. LTD.

ALBION ROAD, WEST BROMWICH.

PHONE: WEST BROMWICH 1025 (7 lines)

London Office: 125 HIGH HOLBORN, W.C.1.

Phone: HOLBORN 8005/6

Heat, 257
 ----- background, 22, 154
 ----- body emission, 7
 ----- loss, 136, 139
 ----- meter, 113
 ----- pump, 104
 ----- topping up, 23
 ----- waste, 138, 153
Heaters, air, 77, 226
 -----, convector, 41, 172, 189
 -----, gas, 184
 -----, unit, gas, 39
 -----, solid fuel, 180
 -----, steam, 40
 -----, water, 40
Heating appliances, local, 170
 ----- chamber, 94
 ----- circuits, 59, 62, 65
 ----- convection, 26
 ----- district, 152
 ----- radiation, 27, 258
 ----- surface cost, 200
 ----- systems, 24, 55, 59, 156
High pressure hot water heating, 60
Hot water heaters, 179, 185, 190
 ----- storage, 161
 ----- supply, 160, 161
 ----- systems, 163
Humidifier, unit, 85, 229
 ----- chamber, 90
Humidification, 83
Humidify, 257
Humidigraph, 258
Humidistat, 128, 258
Humidity control, 33, 47
 ----- indicator, 113
 -----, relative, 8, 16, 258
Hygiene, radiators, 43, 156
Hygrostat, 123

IMMERSION heater, 192
Indicator, CO₂, 116, 251
 -----, humidity, 113
 -----, temperature, 112
Indirect cylinder, 165
 ----- systems, 98, 163
Induced draught, 95
Infiltration, 30, 69
Inlet, fresh air, 74, 79, 206
Instantaneous heaters, 185
Instruments, 112, 249
Insulation, apparatus, 147
 -----, floors, 145
 -----, moisture, 239
 -----, roofs, 145
 -----, sound, 237, 269
 -----, thermal, 139
 -----, vibration, 221, 235
 -----, walls, 143
Intermittent heating, 147, 162, 170, 180, 186
Interposed panel, 50, 212

KITCHEN ventilation, 18, 73

LABOUR saving, 186
Lagging, 149
Lancashire boiler, 101
Linings, firebrick, 239
 -----, insulation, 145
Local heating appliances, 170
Loss of heat, 136, 139
Low pressure hot water heating, 57
 ----- steam heating, 63
Luminous heaters, 182, 187

MAGAZINE boiler, 101
Manometer, 251, 258
Mean radiant temperature, 258
Mechanical draught, 95
 ----- stokers, 109, 235
 ----- ventilation, 30
Meters, air, 251, 259
 -----, feed water, 113, 114
 -----, fuel, 113
 -----, heat, 113
 -----, steam, 114
Micron, 77, 258
Mixing valve, 124, 168
Modulator, 124
Moisture insulation, 239

NATIONAL fuel conservation, 127, 152
Natural gravity circulation, 58, 217
 ----- ventilation, 30, 68, 71
Night control, 124

ODOURS, 16, 18
Oil burners, 109, 243
 ----- firing, 106, 236
 ----- fuel, 131, 272
One-pipe circuit, 59
Open fires, 176
Operational instruments, 112
"Orsat" apparatus, 116
Overfeed stokers, 109
Ozone, 258
Ozonizer, 77

PAINTING, 211, 216, 221
Panel, embedded, 52, 215
 -----, interposed, 50, 212
 -----, positions, 25, 48
 -----, superimposed, 49, 212
 ----- temperature, 60
Peak load, 160
Phon, 57, 258
Pipe accommodation, 220
 ----- circuits, 58, 61
 ----- coils, 38
 ----- conduits, 159
 ----- embedded, 52, 215
 ----- fittings, 217
 ----- insulation, 149
 ----- joints, 217

more heat

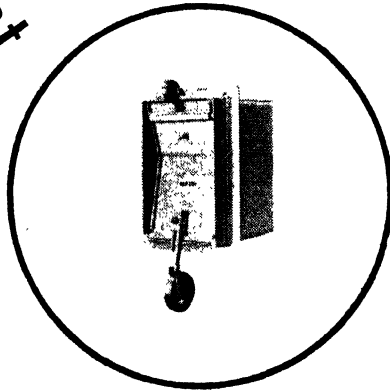

for less fuel

THAT'S what the Aercon Draught Balance can give you. Controlled combustion is part of the answer to your fuel problem. Fuel wastage is cut to a minimum and temperatures remain constant when controlled combustion is instituted. Find out just what the Aercon Draught balance can offer you—'vernier' control of chimney draught, more usable heat, and the self-righting explosion door. Write for more information to :—

**AERCON
DRAUGHT
BALANCE**

JOHN HOARE, LTD., 19-29 WOBURN PLACE, LONDON, W.C.1 • Tel. TER 2617

- Pipe material, 163, 201
 Pitot tube, 251
 Plastic insulation, 149
 Plenum, 258
 — system, 65
 Pollution, atmosphere, 270
 Portable radiant panel, 189
 Power stations, 152
 Preheating, 140
 Primary circulation, 164
 Propeller fans, 73
 Psychrometer, 250, 258
 Pumps, 58, 217
 Pyrometer, 250

 RADIANT panels, 26, 46, 182, 188, 211
 — — — — —, embedded, 52, 215
 — — — — —, interposed, 50, 212
 — — — — —, superimposed, 49, 212
 Radiation, 27, 258
 Radiator, connections, 208
 — shelves, 44
 Radiators, convector, 42, 183, 210
 — — — — —, convector radiant, 45, 210
 — — — — —, electric, 189
 — — — — —, gas, 183
 — — — — —, ventilating, 74, 206, 207
 — — — — —, wall, 44, 209
 Recirculation, air, 65, 88
 Register, air, 79, 224, 225
 Relative humidity, 8, 16, 258
 Remote control, 122
 Reserve equipment, 99
 Resistivity, thermal, 267
 Ring circuit, 59
 Roof insulation, 72
 — — — — — ventilator, 71
 Room temperature, 13
 — — — — — control, 125

 SCALE deposit, 100, 136, 165
 Sectional boilers, 100
 — — — — — radiators, 43
 Shell boilers, 101
 Showers, 168
 Silica gel, 86
 Sizes, boiler house, 93
 — — — — —, chimney, 93, 238
 — — — — —, conduit, 56
 Slow combustion stove, 177
 Sleeves, 219
 Smoke abatement, 127
 Smokeless fuel grate, 176
 Solid fuel appliances, 100, 109, 171, 174
 — — — — — fuels, 273
 Soot, 136, 238, 270
 Sound insulation, 269
 Space warming appliances, 37
 — — — — — methods, 20, 21
 Specification details, 198
 Sprinkler stoker, 109
 Steam boilers, 101, 102, 103

 Steam, exhaust, 61
 — — — — —, pressure recorder, 113
 — — — — —, sub-atmospheric, 63
 — — — — —, systems, 60, 62
 — — — — —, unit heater, 40
 — — — — —, volume meter, 114
 Steel chimneys, 239
 Stokers, mechanical, 109, 235
 Storage, hot water, 161, 185, 191
 — — — — —, oil, 151, 244
 — — — — —, solid fuel, 95, 243
 — — — — —, thermal, 98
 Stoves, 177
 Sulphur, 180
 Superimposed panel, 49, 212
 Supports, 218, 234
 Surface, heating, 200
 — — — — — pyrometer, 250
 System, air, 64
 — — — — —, combined, 31, 78, 81, 164
 — — — — —, direct, 163
 — — — — —, embedded, 31, 78, 81, 164
 — — — — —, hot water, 57
 — — — — —, indirect, 98, 163
 — — — — —, steam, 60

 TANKS, cold water feed, 164
 — — — — — oil storage, 244
 Tap discharge, 167
 Temperature, air, 8, 13
 — — — — —, circulating, 60
 — — — — — control, 119
 — — — — — corrected effective, 257
 — — — — — dew point, 257
 — — — — — dry bulb, 257
 — — — — — effective, 8
 — — — — — equivalent, 8
 — — — — — excess, 118
 — — — — — gradient, 8, 28, 137, 258
 — — — — — indicator, 112
 — — — — — mean radiant, 8
 — — — — — radiant, 250
 — — — — — recorder, 113
 — — — — — tests, 249
 Temporary hardness, 165
 Tenders, analysis of, 200
 — — — — — submission of, 196
 Tests, air flow, 251
 — — — — — CO₂, 251
 — — — — — draught, 251
 — — — — — humidity, 250
 — — — — — temperature, 249, 250
 Therm, 258
 Thermal conductivity, 142, 258, 267
 — — — — — efficiency, appliances, 133, 173
 — — — — — plant, 134
 — — — — — electric generation, 152
 — — — — — insulation, 139, 237
 — — — — — loss, 139
 — — — — — resistivity, 267
 — — — — — storage, 98
 — — — — — transmittance, 142, 258

286 HEATING AND AIR CONDITIONING EQUIPMENT FOR BUILDINGS

- Thermograph, 119, 250, 258
- Thermometer, air, 112
 - , globe, 250
 - , recording, 112
- Thermostatic control, 122
- Thermostats, 121, 258
- Time switch, 124
- Topping-up heat, 23, 154, 259
- Towel rail, 169
- Transmission loss, 148
- Triple purpose appliances, 177
- Tubular heaters, 189
 - shell boilers, 103
- Two-pipe circuit, 59

- UNDERFEED stoker, 109, 236
- Underground conduits, 159
 - flue, 241
 - fuel storage, 244
- Unit, Board of Trade, 259
 - conditioners, 90, 231
 - cooler, 84
 - heat service, 177
 - heaters, 39, 40, 190, 206
 - humidifiers, 85, 229

- VACUUM, steam, 64
- Valves, automatic, 122
 - , concealed, 220
 - , emptying, 220
 - , isolating, 220
 - , mixing, 124, 168
 - , radiator, 209
- Vapour, steam, 63
- Variations, contract, 201
- Variostat, 123
- Velocity, air, 251
- Velometer, 251, 259
- Ventilating radiators, 74, 206, 207
 - systems, 32, 69
- Ventilation, combined, 31, 78
 - , flue, 68, 71, 239
 - , mechanical, 30
 - , natural, 30
- Ventilator, roof, 71
 - , wall, 30, 72
 - , window, 74
- Vibration, insulation, 221, 235
- Volume, air, 17, 29

- WALL insulation, 143
 - radiators, 44, 209
 - temperature, 12, 27
- Washers, air, 77, 88, 90
- Waste heat, 138, 152
- Water analysis, 163
- Weather thermostat, 124
- Wet bulb temperature, 259
- Window, air leakage, 30
 - , double glazed, 35
 - , down draught, 27

- ZONE control, 122

