

Birla Central Library

PILANI (Rajasthan)

Class No :- 621.32

Book No : B706 I

Accession No - 38380

Acc. No.....

ISSUE LABEL

Not later than the latest date stamped below.

--	--	--

ILLUMINATION ENGINEERING

ILLUMINATION ENGINEERING

W. B. BOAST
Professor of Electrical Engineering
Iowa State College

FIRST EDITION
SIXTH IMPRESSION

McGRAW-HILL BOOK COMPANY, INC
NEW YORK AND LONDON
1942

ILLUMINATION ENGINEERING

COPYRIGHT, 1942, BY THE
MCGRAW-HILL BOOK COMPANY, INC.

PRINTED IN THE UNITED STATES OF AMERICA.

*All rights reserved. This book, or
parts thereof, may not be reproduced
in any form without permission of
the publishers.*

PREFACE

Illumination engineering is a study of certain concepts originating from two quite different philosophies of life. On the one hand we have a philosophy based upon the concepts of energy and matter as being entities within themselves. The outgrowth of this philosophy has been the formulation of our physical laws relating the behavior of things. However, most of us believe that our existence cannot be explained wholly upon the basis of these concepts of energy and matter as we use them in this objective philosophy.

The outgrowth of the other philosophy of life, which we may call the *subjective philosophy*, has been the formulation of that concept called our *consciousness*. Such a concept appears in the fields of religion and psychology and in some parts of the field of physiology. The illumination engineer is particularly interested in those aspects of the fields of psychology and physiology pertaining to the part that consciousness plays in the sensation of sight.

Illumination engineering is in a very general sense simply a means to an end—a means of attaining this sensation of sight. Being such a prelude to seeing, the subject must be studied with the thought always in mind: How will this illumination be utilized? A study of illumination as a thing apart is a study in physics; a study of illumination with a thought to utilization is engineering. There is need for both types of study. However, the viewpoint of this text is that of *illumination engineering*. The text is designed as a general outline of study for electrical engineering students.

Terminology in illumination engineering, as perhaps in few other fields, has been very loosely established by the practicing engineer and in some cases, the author believes, even by the authoritative governing bodies. An attempt has been made in this presentation to conform to terminology established by the authorities in the field wherever such terminology does not lead to confusion. In those cases where it is felt that the terminology

does lead to confusion, a very definite statement to that effect is made. Any terminology used in preference to that accepted by the Illuminating Engineering Society is fully explained. To facilitate reference to these terms as well as to the standard definitions, a listing of the new terms used in each chapter will be found at each chapter heading. This is rather an unprecedented procedure in texts, but it is believed that the end justifies the means.

In several references involving the units of brightness and luminosity the author has taken the liberty of converting data in these references to such units as conform to the notations of this text.

No illustrations of lighting systems are included in the text. Such adaptations of the fundamentals of illumination engineering are usually dependent upon the available commercial equipment. As a result certain illustrations of any collection soon become obsolete and need replacement. The author has found the two- by two-inch slide a most convenient tool in this respect. Slides in color, as those in black, and white, are now feasible at very reasonable expense.

Tables of lamp data are issued periodically and hence no text publication can be up to date with respect to such data. For study purposes, however, the inclusion of these tables in the text is highly desirable. Obviously the latest issues of such catalogue material should be referred to for the actual application of equipment.

The author wishes to acknowledge the help and suggestions of his fellow workers, both past and present, in electrical engineering at Iowa State College, and especially those of Professor R. W. Ahlquist, who has been associated with him in the teaching of illumination engineering during the preparation of this text.

W. B. BOAST.

AMES, IOWA,
February, 1942.

CONTENTS

	PAGE
PREFACE	v
CHAPTER 1	
THE SPECTRORADIOMETRIC FUNCTION.	1
The frequency spectrum—Radiation from line-spectrum and continuous-spectrum sources—Black-body radiators—Fluorescence and phosphorescence.	
CHAPTER 2	
THE LUMINOSITY FUNCTION.	14
The human eye as a detector of brightness—The work of Gibson and Tyndall—Relative spectral visibility and the luminosity function—Other spectral response functions.	
CHAPTER 3	
THE ILLUMINATION SYSTEM	19
Measurements, units, and the fourth auxiliary fundamental—Brightness and its position in the illumination system—Luminous sources.	
CHAPTER 4	
ENTITIES IN THE ILLUMINATION SYSTEM AND THEIR UNITS.	24
Illumination—Intensity—Brightness—Luminous Flux—Light—Luminosity—Summary	
CHAPTER 5	
MEASUREMENT OF ILLUMINATION	47
Visual comparison methods—Macbeth illuminometer—Light-sensitive cells—Determination of apparent intensity—Determination of total luminous flux emitted by a luminous source.	
CHAPTER 6	
GEOMETRIC GRAPHS AND THEIR APPLICATIONS.	61
Intensity-distribution curves and their application—Brightness-distribution curves and their application—Illumination-distribution curves—Relationship between brightness and luminosity for a perfectly diffusing source.	
CHAPTER 7	
DETERMINATION OF ILLUMINATION FROM SURFACE AND LINE SOURCES	77
Plane-surface source of infinite extent—Hemispherical source from	

the inside—Circular disk source—Rectangular source—Strip source
—General source of irregular shape.

CHAPTER 8

ABSORPTION, REFLECTION, AND TRANSMISSION OF LUMINOUS FLUX . . . 96
Absorption—Reflection and reflection factor—Transmission and
transmission factor—Filter data.

CHAPTER 9

ELECTRICAL LIGHT SOURCES AND THEIR OPERATING CHARACTERISTICS 112
History of the incandescent lamp—Incandescent-lamp ratings—
Operating characteristics of multiple tungsten-filament lamps and
the economics of lamp-voltage variation—Effects of filament evap-
oration—Mercury-vapor lamps—Sodium-vapor lamps—Fluores-
cent lamps—Operating characteristics of fluorescent lamps.

CHAPTER 10

ILLUMINATION STANDARDS. 159
Luckiesh-Moss visibility meter—Recommended illumination stand-
ards for stores, commercial and public interiors, and industrial
interiors.

CHAPTER 11

DESIGN OF INTERIOR LIGHTING SYSTEMS USING COMMERCIAL LUMI-
NAIRES 173
Work of Harrison and Anderson—Spacing and mounting height
of luminaires—Room index—Coefficients of distribution—Three-
curve calculation method—Coefficients of utilization for incan-
descent and fluorescent luminaires—Computation of illumination.

CHAPTER 12

LUMINOUS ARCHITECTURAL ELEMENTS 202
General types of elements—Exterior and interior applications of
luminous elements—Reflecting and transmitting materials—
Spacing of lamps in luminous elements for reasonably uniform
brightness—Calculations upon element forms.

CHAPTER 13

TESTING OF ILLUMINATION SYSTEMS BY SAMPLES AND MODELS. . . 220
Testing by samples using the image method—Testing by models.

CHAPTER 14

DESIGN OF FLOODLIGHTING SYSTEMS. 229
The general problem—Beam spread—Location and types of equip-
ment—Recommended levels of illumination—Calculations for
floodlighting—Spot sizes—Setback floodlighting design—Recrea-
tional lighting.

CONTENTS

CHAPTER 15

PAGE

DESIGN OF STREET-LIGHTING SYSTEMS 251

Visibility and methods of discernment—The general design problem—Surface brightness of streets and highways—Evaluation of discernment by silhouette—Evaluation of loss in visibility because of glare—Relationship between the Illuminating Engineering Society code classifications of traffic and relative visibility—Critical discussion.

INDEX 269

ILLUMINATION ENGINEERING

CHAPTER 1

THE SPECTRORADIOMETRIC FUNCTION

<i>Symbol</i>	<i>Term</i>	<i>Definition</i>
	Radiation	The act or process of emitting energy from sources. In a very general sense, also, that which is emitted.
W	Radiant energy	Strictly that which is emitted by the radiation process. (Typical unit, joules.)
P	Radiant power	The rate at which radiation is accomplished. (Typical unit, watts.)
P/A	Radiant-power density	The area density of radiant power. (Typical unit, watts per square centimeter.)
J	Emission	Radiant-power density <i>emitted, transmitted, or reflected</i> (secondary emission) by a source. (Typical unit, watts per square centimeter.)
G	Irradiation	Radiant-power density <i>incident</i> upon a receiving surface. (Typical unit, watts per square centimeter.)
J_λ	Spectral emission	Radiant-power density per unit of wave length at λ wave length <i>emitted, transmitted, or reflected</i> by a source. (Typical unit, watts/square centimeter per micron.)
G_λ	Spectral irradiation	Radiant-power density per unit of wave length at λ wave length <i>incident</i> upon a receiving surface. (Typical unit, watts/square centimeter per micron.)

1. The Frequency Spectrum.—Much of the theory of illumination is based primarily upon the wave theory of radiation and the frequency spectrum. As a result, this presentation will utilize the concept of wave radiation and the associated items of wave length, velocity of propagation, and frequency of the radiation.

It should be realized, however, that the wave theory of radiation is not alone sufficient for a complete explanation of the phenomena of light. A great deal in the way of photoelectric effect, radiation from hot bodies, and the radiation from atoms cannot be explained satisfactorily on the basis of this theory. For an explanation of such items another concept is necessary. This states that energy is emitted or absorbed only in discrete quanta of magnitude $h\nu$,

where h = Planck's constant = 6.547×10^{-27} erg-second.

ν = frequency, in cycles per second.

Wave mechanics attempts to correlate these two concepts of radiation by assuming that the wave theory is a mathematical conception which tells how and where the propagation is accomplished, but that at the sending and receiving ends of the path an interpretation must be accomplished through the quantum theory.

To repeat, this presentation will utilize the notation of the wave-radiation theory. This notation is justifiable inasmuch as most of the phenomena of illumination engineering involve conditions that exist in the path of the radiation or of those conditions as one approaches the source or the receiving surface.

Evaluation of conditions in or as one approaches the extremes of the path can be accomplished only through an energy conversion. Instead of dealing with energy quantities or densities that may exist in a path in an interval of time, a much more desirable procedure is an elimination of the time element. This results in evaluating the rate of radiant-energy density, *i.e.*, in evaluating the radiant-power density. More will be said of the evaluation later.

Whatever the preceding process is, an important specification of the radiation is a statement of its frequency or frequencies. If the radiation is homogeneous, *i.e.*, of a single frequency or of a narrow band of frequencies, a statement of its magnitude and of its frequency completely specifies the radiation. If the radiation is heterogeneous, a more complete specification is necessary. This subject is discussed in detail in Arts. 2 and 3.

Since frequency is fixed independently of the medium through which the wave passes, it would seem desirable to express the

radiation as a function of frequency. Common usage, however, has established the precedent of expressing such values as functions of the wave lengths that result in free space. Since the distinction is trivial, this notation will be used in this presentation. The well-known relationship relating the frequency and the wave length in free space is

$$\nu = \frac{3.00 \times 10^{10}}{\lambda} \quad (1)$$

where ν = frequency, in cycles per second.

λ = wave length, in centimeters.

The known range of the radiant-energy spectrum extends over a tremendous range of wave length. A 60-cycle a.-c. circuit has a wave length in free space of 5×10^8 cm., or approximately 3100 miles. On the other extreme, radiant energy associated with cosmic rays has wave lengths of the order of 10^{-10} to 10^{-12} cm. Radiant energy easily visible to the human eye has wave lengths between the approximate limits of 0.40×10^{-4} and 0.76×10^{-4} cm.

The micron, a much smaller unit of length than the centimeter, is more convenient to use in specifying wave lengths encountered in illumination work. Also used in the range of wave lengths associated with light is the angstrom unit. Relationships among the units of centimeters, microns, and angstroms are

$$\begin{aligned} 1 \text{ cm.} &= 10^4 \text{ microns } (\mu) \\ &= 10^8 \text{ angstrom units } (\text{\AA}) \end{aligned}$$

Thus the range of wave lengths of the visible spectrum is approximately from 0.40 to 0.76μ , or from 4000 to 7600 \AA . The symbols μ and \AA . as given above will be used as abbreviations of the names of the units of micron and angstrom, respectively.

2. Radiation from a Line-spectrum Source.—Radiant energy from a gaseous-discharge source, such as mercury vapor, sodium vapor, neon, and many others of this type, consists of a radiation made up of one or more homogeneous component radiations. The radiation at definite wave lengths is a function of the molecular or atomic structure of the gas carrying the discharge. Con-

sequently each substance has characteristic wave lengths of its radiation. Such radiation is commonly called *luminescence*, although this term strictly applies to all types of radiation not directly associated with temperature.

If a radiation path exists, it can be detected rather simply by placing a radiation thermocouple (Fig. 1) in the path and noting the deflection of the galvanometer. The blackened target of the device absorbs the radiant energy and transfers it into thermal energy. This energy then is used in establishing the temperature of one of the junction points of the thermocouple. If the other junction point of the thermocouple is maintained at a

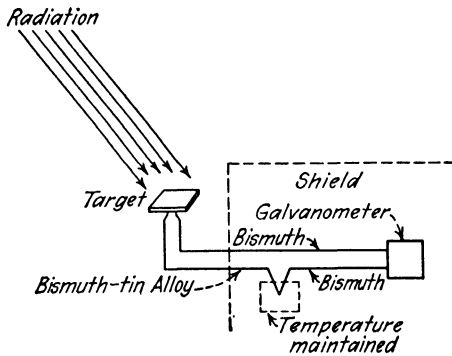

FIG. 1.—A radiation thermocouple.

different (usually lower) temperature, the difference in temperatures of the junction points produces a small electromotive force which in turn produces a current flow and the galvanometer deflection. Such a device is very independent of the frequency when a proper target is used.

If the radiation consists of several component homogeneous radiations at various frequencies, the measurement of the total irradiation as made with the radiation thermocouple does not completely specify the radiation, since it does not tell how the power density is distributed among the various wave lengths. To obtain this complete specification of the radiation a spectroradiometer (Fig. 2) is necessary. The elements of this device are the first slit S_1 , which admits the radiation through a lens a to the prism b . After the ray passes through the prism and is

refracted according to wave length, it is conveniently distributed by lens *c* upon a movable shielded radiation thermocouple *d* which can be adjusted to allow a narrow wave-length band, entering through slit *S*₂, to be studied independently of all the remainder of the spectrum.

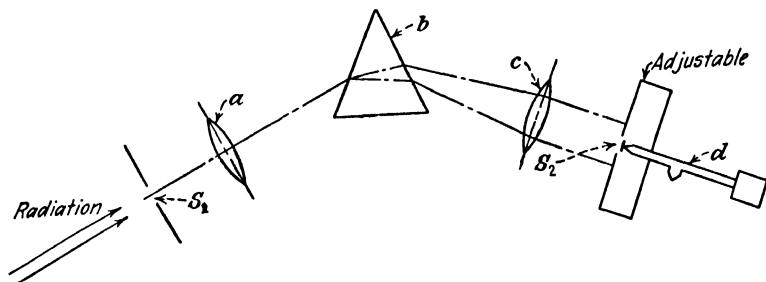

FIG. 2.—A spectroradiometer.

By the use of this arrangement it is possible to obtain the radiant-power density at each increment of the wave length admitted to the slit *S*₂. The only restriction on the width of the slit is that it be narrow enough so that not more than one component radiation can enter it. If two or more components are very close together, it may not be practical to separate them.

Data on the irradiation resulting from several vapor-lamp sources for certain stated conditions are given in Figs. 4 and 5. The summation of the component irradiations for any one of the sources gives the total irradiation for the stated condition. Expressed mathematically,

$$G = \sum_1^n G_i \quad (2)$$

where *G* = total irradiation.

*G*_{*i*} = irradiation due to the *i*th component.

n = number of component radiations.

Assume that the data given in Fig. 3 represent the distribution of component irradiations for a fictitious source at a specified receiving surface. If all component irradiations are within the range of 0.2 to 1.0 μ as shown in the figure, the summation of

components yields $5 + 10 + 3 + 12 + 20 + 6 + 4 + 2 = 62$ microwatts per square centimeter. Of this irradiation

$\frac{5}{62}$, or	8.06 per cent,	is at 0.26μ wave length
$\frac{10}{62}$, or	16.13 per cent,	is at 0.32μ wave length
$\frac{3}{62}$, or	4.84 per cent,	is at 0.43μ wave length
$\frac{12}{62}$, or	19.35 per cent,	is at 0.46μ wave length
$\frac{20}{62}$, or	32.26 per cent,	is at 0.48μ wave length
$\frac{6}{62}$, or	9.68 per cent,	is at 0.67μ wave length
$\frac{4}{62}$, or	6.45 per cent,	is at 0.83μ wave length
$\frac{2}{62}$, or	3.23 per cent,	is at 0.92μ wave length
Total 100.00 per cent		

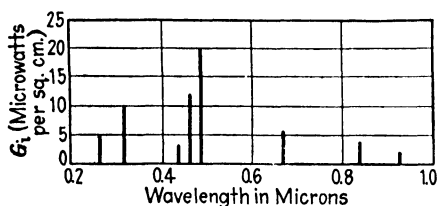

FIG. 3.—Irradiation from a fictitious line-spectrum source at a specified receiving surface.

The foregoing information completely specifies the radiation from this source for the specified receiving surface in so far as most practical usages are concerned. It does not, however, give

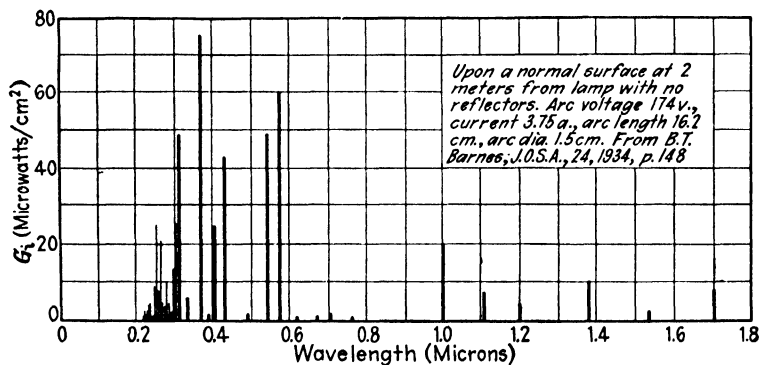

FIG. 4.—Irradiation from a high-pressure mercury vapor lamp.

information regarding polarization or several other concepts that may be useful under certain rather special conditions.

A representation of the radiation components as in Fig. 3 will be termed the *spectroradiometric function* for a line spectrum source. The magnitude of the component radiations are very

dependent upon the specified conditions of the test; *i.e.*, the *density* of the radiant power generally becomes much larger when the observations are made closer to the source. The relative values of the component radiations from a given source, however, do not depend upon spacing unless there is selective absorption in the transmitting or reflecting medium (if such is present).

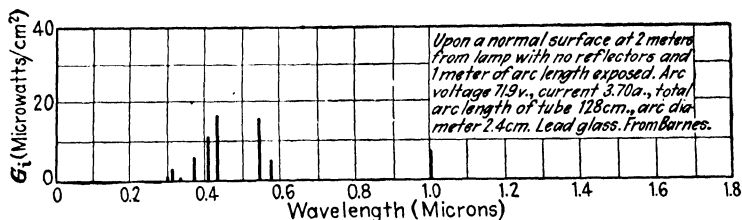

FIG. 5.—Irradiation from a low-pressure mercury vapor lamp.

3. Radiation from a Continuous-spectrum Source.—A body at any temperature other than absolute zero will radiate energy over a wide range of wave lengths. Such radiation is called *incandescence*, or temperature radiation. A hot ingot of steel is an incandescent source, very effective in producing infrared radiations. The incandescent-lamp filament is the most common artificial incandescent source from an illumination viewpoint.

To express how such a radiation is distributed in the wave length spectrum, let the width of the slit S_2 , in the spectroradiometer of Fig. 2, be fixed arbitrarily so as to admit a band of wave lengths of, say, 0.01μ . The width of the slit has a direct bearing upon the accuracy of the results if the spectral distribution of the radiation varies greatly as a function of wave length. This is especially true if there are very sharp peaks in the curve.

The resulting measurement as made by the thermocouple will involve the width of the slit as well as the radiant-power density of the radiation. Obviously if the width of the slit is doubled, the reading of the thermocouple will be increased; and if the radiation as a function of wave length is uniform, the reading would be doubled. Hence it is desirable to establish a standard width of slit so that all results will have understandable meanings. The width established *simply on the basis of convenience of units* has been the micron. Values measured by a slit width of 0.01μ must be multiplied by 100 to establish the reading on the basis

of a micron-width slit. In the investigation of a range of wave lengths from 0.40 to 0.76μ wave length, it is obvious that a slit of 1μ width (on the spectroradiometer scale) would yield no useful information. Therefore it cannot be emphasized too strongly that a unit of radiation from a continuous-spectrum source of 1 microwatt per square centimeter per micron has little physical significance and that a much more narrow band of frequencies is used for the measurement.

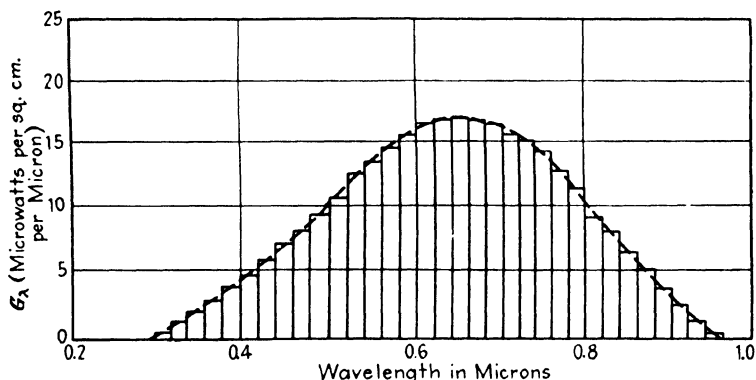

FIG. 6.—Irradiation from a fictitious continuous-spectrum source at a specified receiving surface.

Results of the readings from a fictitious source for a slit width admitting a band of frequencies of 0.02μ wide, when multiplied by 50 and plotted as a step curve, would appear as in Fig. 6.

The summation of the individual readings (actual microwatts per square centimeter with no factor of 50 applied) can be checked to be 6.1 microwatts per square centimeter. Obviously this is the total irradiation, assuming that there is no radiation outside the range of 0.2 to 1.0μ . The area of the curve as plotted (including the factor of 50 in the ordinates) is also 6.1 microwatts per square centimeter when there is due regard for the two scales. Hence the artificially broad slit width of 1μ for a unit of G_λ is justified on the basis of convenience in obtaining results when the wave-length scale is plotted in microns.

Instead of plotting results as step curves from such readings, it is usual to plot them as smooth curves joining the midpoints of the band width used. Planimeter methods yield rather accurate results when the curves are plotted to scales comparable with the accuracy of the data.

The representation of the radiation as a smooth curve (as the dotted curve of Fig. 6) will be termed the *spectroradiometric*

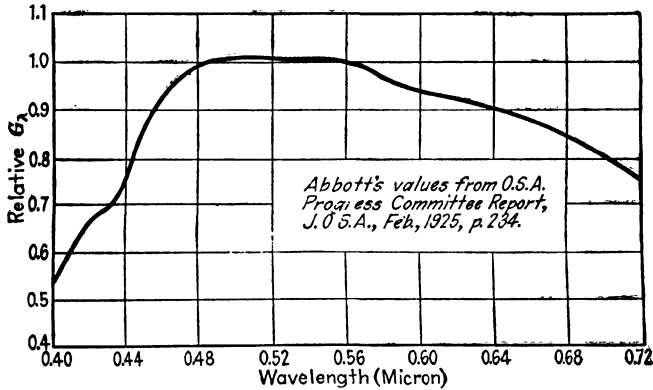

FIG. 7.—Average noon sun at Washington, D.C.

function for a continuous-spectrum source. Expressed mathematically,

$$G = \int_0^{\infty} G_{\lambda} d\lambda \quad (3)$$

where G = total irradiation.

G_{λ} = spectral irradiation at λ wave length.

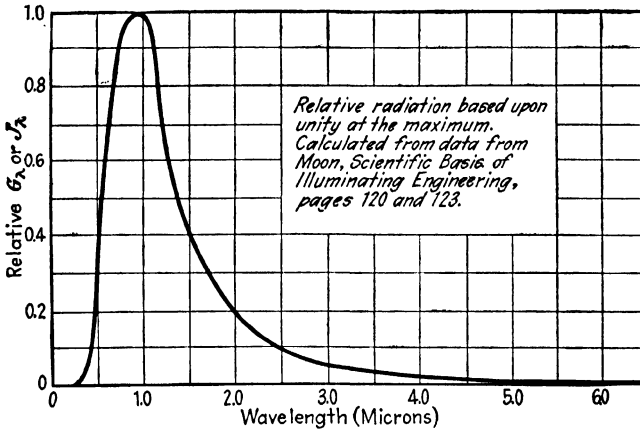

FIG. 8.—Incandescent lamp at 2950°K.

Data on radiation from several representative continuous-spectrum sources are given in Figs. 7 to 9.

4. Radiation from Black-body Radiators.—The International Committee on Weights and Measures at its biennial meeting in Paris, June 23–29, 1937, adopted a new system of photometric units based upon the brightness of a black-body radiator at the temperature of solidification of platinum. As a result any discussion of illumination standards must include in some detail the black-body radiator.

A black body is defined as any body that absorbs all incident radiant power at all temperatures. Since a body at a constant temperature radiates the same amount of power that it receives, it follows that a black body at a constant temperature radiates more power than any other incandescent radiator operating at the same temperature.

Black-body radiation can be approached very closely by an almost completely enclosed cavity whose walls are opaque and maintained at the required temperature. The degree of uniformity of temperature and the relative smallness of the opening determine the degree to which black-body radiation can be approached.

By means of equipment approaching black-body radiators very closely, various experimenters have determined the spectral emission in watts per unit area per unit of wave length at various temperatures. From such data Planck derived the empirical equation that applies with great accuracy for radiation in the visible region.

$$J_{\lambda} = \frac{C_1}{\lambda^5} \frac{1}{e^{C_2/\lambda T} - 1} \quad (4)$$

where J_{λ} = spectral emission, in watts per square centimeter of emission surface per micron wave-length band at a wave length of λ .

λ = wave length, in microns.

T = temperature, in degrees Kelvin.

C_1 = 36,970.

C_2 = 14,330.

The solidification temperature of platinum has been measured by laboratories in the leading technical countries of the world, and an agreement upon 2046° K. has been made. If the values of the constants C_1 and C_2 and of $T = 2046^{\circ}$ are substituted in the preceding equation (the negative one in the denominator has

no significance at this temperature when λ is of magnitudes encountered in the visible region), the equation becomes

$$J_{\lambda} = 36,970\lambda^{-5}\epsilon^{-7.004/\lambda} \quad (4a)$$

This spectral distribution of radiant-power density per unit of wave length constitutes the basis for the new system of

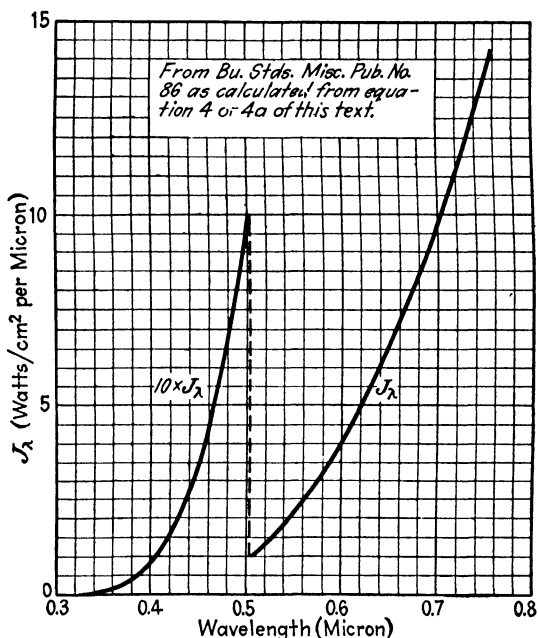

FIG. 9.—Black-body radiator at 2046°K.

photometric units. A great deal more will be said of these units later. Figure 9 gives results of equation (4a) as a function of wave length from 0.32 to 0.76 μ .

5. Radiation from Other Types of Source.—Radiations classified as luminescence and incandescence have been discussed under the topics of radiations from line-spectrum and continuous-spectrum sources respectively. In addition to these two classifications two other types of radiation are known to exist.

Fluorescence (in a strict sense one type of luminescence) is demonstrated by the new fluorescent lumiline lamps which were in the process of development for several years and which were placed on the commercial market in 1938.

This type of radiation deserves a separate classification because the initial radiation is of a luminescent character due to an electrical discharge in low-pressure mercury vapor; but a frequency change in some of this radiation is brought about by allowing the radiation (a large part of which is below 0.4μ) to impinge upon a powder that converts that part of the radiation into a continuous-spectrum radiation at a longer wave length. No long-time storage process is involved in the fluorescent lamp, although fortunately the phosphors used in these lamps do exhibit a

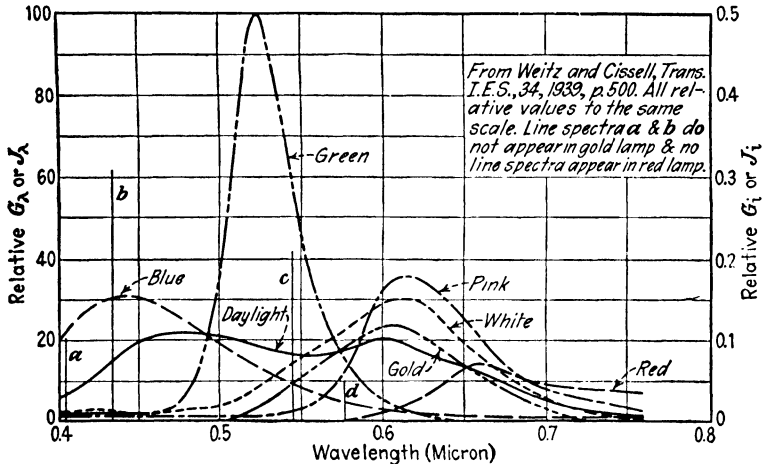

FIG. 10.—Relative radiation from several fluorescent lamps operating at the same total power input.

short-time storage of energy, as considered below under phosphorescence.

Figure 10 presents data on various commercial fluorescent lumiline lamps. It will be noted that the radiation contains both line- and continuous-spectrum distribution.

The remaining type of radiation is termed *phosphorescence*. Here energy is received by the body in some form consistent with the radiating body. A storage of this energy takes place, and the radiation is accomplished either during the irradiation or after the source of energy is removed. Certain radium compounds exhibit the characteristic. Also, the chemicals of the fluorescent lamp phosphoresce to such an extent as to reduce the flicker, or stroboscopic action, of some of these lamps considerably. The powders used in the blue lamp exhibit practically

no phosphorescent action, whereas those of the red lamp phosphoresce to such an extent that at 60 cycles the deviation of the luminous output from the mean is only 10 per cent.

Problems

1.1. What is the total irradiation upon a normal surface 2 m. from a high-pressure mercury-vapor lamp with no reflectors, using the data from Fig. 4? What percentage of this irradiation is in the wave-length band from 0.40 to 0.76 μ ?

2.1. If the total irradiations are the same upon two surfaces radiated by the high-pressure mercury-vapor lamp and the low-pressure mercury-vapor lamp of Figs. 4 and 5, respectively, what are the relative irradiations due to the 0.5461 μ -line of the spectrum?

3.1. If the total irradiation upon a surface radiated by an incandescent lamp operating at 2950°K. is 1.5 milliwatts per square centimeter, what is the power density of this irradiation in the wave-length band from 0.40 to 0.76 μ ?

4.1. What are the relative emissions between 0.40 and 0.76 μ wave length for the daylight and for the green fluorescent lumiline lamps of Fig. 10?

REFERENCES

- Report of O.S.A. Progress Committee on Spectrophotometry, *J. Optical Soc. Am.*, **10**, 1925, pp. 169-241.
- J. F. Skogland, Tables of Spectral Energy Distribution, *Bur. Standards, Misc. Pub.* 86, 1929.
- B. T. Barnes, Spectral Distribution of Radiation from High and Low Pressure Hg Arcs, *J. Optical Soc. Am.*, **24**, 1934, pp. 147-148.
- P. Moon, "The Scientific Basis of Illuminating Engineering," McGraw-Hill Book Company, Inc., New York, 1936.
- C. E. Weitz and R. F. Cissell, Spectral Analysis of Radiant Energy, *Trans. Illum. Eng. Soc. (N.Y.)*, **34**, 1939, pp. 495-502.

CHAPTER 2

THE LUMINOSITY FUNCTION

<i>Symbol</i>	<i>Term</i>	<i>Definition</i>
	Subjective	Relating to something within the mind or consciousness of human beings.
	Objective	Relating to objects; having the nature of an object or being that is thought of or perceived, as opposed to that which thinks or perceives.
	Color	The sensation due to stimulation of the optic nerve. Color is subjective.
	Brilliance	That attribute of color in respect of which all colors may be classified as equivalent to one or another of a series of grays of which black and white are the terminal members.
	Hue	That attribute of color in respect of which it differs from gray. That attribute in respect of which colors may be classified as reddish, yellowish, greenish, or bluish.
	Saturation	The degree of purity or vividness of hue.
v_{λ}	Relative visibility	The ratio defined in equation (5).

6. Purpose.—In the previous chapter the statement has been made that radiations easily visible to the human eye have wave lengths between the approximate limits of 0.40 and 0.76 μ . The purpose of this chapter is to establish a definite meaning to “easily visible,” consistent with that adopted by international agreement by the International Commission on Illumination, in 1924 in Geneva, Switzerland.

7. The Human Eye.—The physiology of the human eye is well described in many reference works and will not be dealt with extensively here. The subjective evaluation of surfaces of objects, or things, as viewed by the eye and interpreted by the individual has, in the process of the development of our scientific and artistic ideas, been treated in three classifications. All these three classifications are grouped by the layman as “color.”

One of the classifications conceived by those individuals responsible for the earlier systems thus established is the attribute of color in respect of which all colors may be classified subjectively

as equivalent to one or another of a series of grays of which black and white are the terminal members. This attribute is called *brilliance*. Its objective counterpart will later be defined as *brightness*.

A second classification of color is that attribute in respect of which it differs from gray; *i.e.*, according to this subjective grouping, colors may be classified as reddish, yellowish, greenish, or bluish. This attribute is called *hue*.

The third classification of color is the degree of purity or vividness of the hue. Two colors may be subjectively evaluated by an individual as having the same brilliance and the same hue, but one may seem to contain more white than the other. Conversely one would evaluate the second color as being a more vivid or pure color than the first. This attribute is called variously *saturation*, *purity*, or *vividness* of hue.

These three attributes have guided the philosophy of specifying colors according to a great number of specification systems, each of which attempts to condense the general data form of the spectroradiometric function.

A complete study of color-specification systems is beyond the scope of this text. The philosophy herein is to treat the human eye as simply a detector of brightness, which in turn yields the sensation of brilliance. In so doing the magnitude of the result is obtained, but the classification according to the other attributes of color is lost. The treatment of the magnitude alone presupposes that the brilliance attribute of color can be separated from its other attributes, *viz.*, hue and saturation.

Such was the premise of Gibson and Tyndall working at the National Bureau of Standards in cooperation with the Nela Research Laboratories about 1921. It is upon their results of brilliance-comparison tests performed by 52 observers that the International Commission of Illumination (Commission Internationale de l'Eclairage) adopted in 1924 a set of values known generally as the *C.I.E. values* of visibility. (The letters I.C.I. for the English name are sometimes used.)

8. The Work of Gibson and Tyndall.—K. S. Gibson, physicist, and E. P. T. Tyndall, research associate for the National Bureau of Standards, have reported their work on "Visibility of Radiant Energy" in *National Bureau of Standards, Scientific Papers*, 475.

A comparison of the brilliance of the two half fields of the divided-circle type of photometer field subtending an angle of

3 deg. was made by their observers by the step-by-step method. The method obtains its name from the fact that the observer compares the two fields when irradiated by radiant energies only slightly different in wave length. The magnitude of the irradiation at one of these wave lengths is held fixed, and a variable magnitude radiant energy of an adjacent wave length matched against it until an equality of brilliance is attained to the satisfaction of the observer. The procedure is then repeated with adjacent wave lengths until the observer has covered the spectrum over the range where reasonable irradiations will produce balances.

The size of the steps between wave lengths that are compared is held small enough so that "little or no hue difference is perceptible." The necessity of keeping the wave lengths under comparison reasonably close together is readily apparent to anyone who has attempted comparison-of-brilliance tests utilizing fields differing very greatly in hue.

9. Relative Visibility.—The minimum emission from one of the test surfaces necessary to give the arbitrary choice of original brilliance was found by Gibson and Tyndall to be at a wave length of 0.55μ . At all other wave lengths a greater amount of emission was required. The relative visibility at any wave length λ , then, can be defined as

$$v_{\lambda} = \frac{J_{0.55\mu}}{J_{\lambda}} \quad (5)$$

where v_{λ} = relative visibility at λ wave length.

$J_{0.55\mu}$ = emission of 0.55μ wave length from one of the test surfaces.

J_{λ} = emission of λ wave length giving a brilliance-comparison balance from an identical test surface.

From their determinations, Gibson and Tyndall recommended certain changes in the values of relative visibility which at that time were being used as tentative standards by the Illuminating Engineering Society. Their recommendations were made with the consideration of the results of other investigators of that period, including Hyde, Forsythe, Cady, Coblenz, Emerson, Nutting, Reeves, So, Ives, and Priest.

A listing of the values which were recommended to and subsequently accepted by the Geneva Conference and which are

regarded as standard today is given in Fig. 11. The variation of relative visibility as λ takes on various values constitutes the luminosity function. Note that the independent variable for both the spectroradiometric function and the luminosity function is wave length of the radiation.

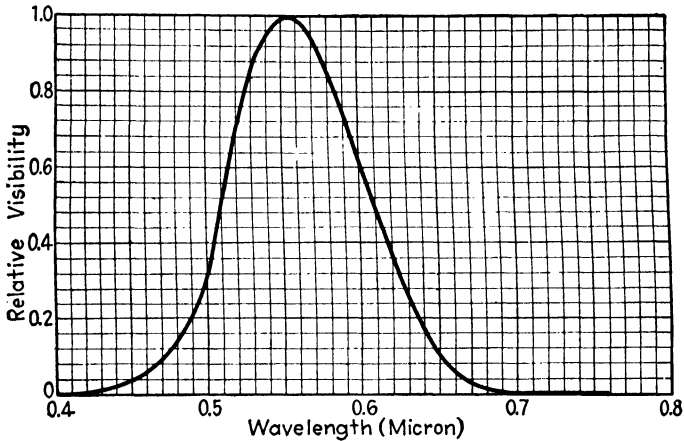

FIG. 11.—The luminosity function.

10. Other Spectral Response Functions.—Illumination engineering is concerned principally with the usage of radiant energy by the human eye. However, radiant energy of the range of wave lengths from 0.40 to 0.76μ and in adjacent wave-length bands produces other effects where the proper receiver is present. Many of these effects may be evaluated in much the same manner as is the luminosity function, *i.e.*, as a relative response.

One example of such usage is found in the field of photography where a chemical change as a function of wave length may be expressed as the spectral response of the film emulsion. An additive factor of time enters here, however, so that the response is more that of a true energy or energy-density evaluation, whereas in the illumination field the response is a power or power-density evaluation.

The action of radiant energy in the ultraviolet range (below 0.40μ) in reddening and tanning the human skin is an effect that has been studied. The spectral response or irritation of the skin of certain individuals has been determined. Germicidal action has also been noted to have a spectral response.

Photoelectric responses of several types of equipment also fall in this category. Here, however, the response need not be simply relative, because the magnitude of cause and effect can both be measured objectively. Chapter 5 deals in detail with these devices, since they are of extreme importance to the illumination engineer.

Problems

1.2. Emissions from two sources are identical as to magnitude and the geometrical distribution of the radiant energy from the surfaces. The emissions are both of a line-spectrum nature. However, the emission from surface *a* has a single radiation frequency of 5.66×10^{14} cycles per second, whereas the emission from surface *b* has a single radiation frequency of 5.41×10^{14} cycles per second. What is the relative effectiveness of these sources in producing visual effects?

2.2. If the radiation frequency of the emission from surface *a* had been 3.80×10^{14} cycles per second, would the surface have been capable of producing the sensation of brilliance?

REFERENCES

- I. T. Troland, Brilliance and Chroma in Relation to Zone Theories of Vision, *J. Optical Soc. Am.*, **6**, 1922, p. 3.
- L. T. Troland, Report on Colorimetry, *J. Optical Soc. Am.*, **6**, 1922, p. 527.
- Gibson and Tyndall, Visibility of Radiant Energy, *Nat. Bur. Standards, Sci. Papers*, **19**, 1923, p. 131.
- P. Moon, Color Determination, *Trans. Illum. Eng. Soc. (N.Y.)*, **36**, 1941, pp. 313-335.
- D. B. Judd, Color Systems and Their Inter-relation, *Trans. Illum. Eng. Soc. (N.Y.)*, **36**, 1941, pp. 336-372.
- Colour: Its Production, Use and Specification, *Light and Lighting*, **34**, 1941, pp. 40-41.

CHAPTER 3

THE ILLUMINATION SYSTEM

<i>Sym- bol</i>	<i>Term</i>	<i>Definition</i>
	Physical	Pertaining to the material universe.
	Physiological	Pertaining to the functions of living organisms.
	Psychological	Pertaining to the human mind and its operations, powers, and functions.
<i>B</i>	Brightness	The objective stimulus evoking the sensation of brilliance. (Typical unit, candles per square centimeter of projected area.)

11. Measurements, Units, and the Fourth Auxiliary Fundamental.—Engineering makes use of physical, physiological, and psychological quantities in the broadest sense of these terms. In order adequately to compare these quantities of the same kind, it is necessary to establish size, or units. This has been accomplished rather completely in the physical sciences. Classifications have been made in the physiological and psychological fields, but very little has been accomplished in the manner of true measurements.

Considering, then, the physical sciences, where measurements are being made with certainty, three fundamental concepts seem to suffice in the dynamical system, *viz.*, mass, length, and time. In other systems it is necessary to introduce an additional auxiliary fundamental concept.

For example in the electrostatic system, electric charge can be treated as the auxiliary fundamental concept, although charge density, electric field intensity, electric potential difference (or electromotive force), electric flux, electric flux density, dielectric constant (relative permittivity with respect to that for free space as unity), capacitance, or possibly some other concept could be used for the basic fourth idea. The point is that once one is selected all the others can be derived from it and the three primary fundamental concepts of mass, length, and time.

In the magnetostatic system likewise a magnetic pole can be treated as the fourth auxiliary concept in that system, although

again magnetic field intensity, magnetic potential difference (magnetomotive force), magnetic flux, magnetic flux density, relative permeability with respect to that for free space as unity, inductance, or possibly some other concept could be used here for the basic fourth idea.

These two static systems can be considered component parts of a composite dynamic electromagnetic system using a single fourth concept. When dynamic relationships are involved, the two systems are then not strictly independent of each other but can be related through the velocity of an electromagnetic radiation in free space. When this combination is accomplished, a choice *still* must be made as to what shall constitute the fourth auxiliary concept in this composite system.

With a dynamical electric-magnetic combination an additional concept is introduced with all of its ramifications, *viz.*, the rate of change of charge (or the current) in the electrical circuit of the two interlinking composite parts. The immediate ramification associated with this new concept is resistance to current flow. A unit of resistance no doubt lends itself most readily to the preservation (through a material substance) of all the concepts discussed above. However, it is very doubtful if it constitutes a logical fundamental concept. The Electrical Advisory Committee of the International Conference on Weights and Measures in June, 1938, felt that no one concept at the present time justified a choice over all others. Consequently when they chose the meter, kilogram, and second for units of length, mass, and time respectively for the new (MKS or Giorgi) system of electromagnetic units which should take the place of the international system on Jan. 1, 1940, they simply fixed the size of the permeability of free space without recommending a "fourth" fundamental unit in the electromagnetic system.

Consider one more system—the caloric system—and its fourth fundamental concept before progressing to the illumination system. The fourth fundamental concept generally attributed to the caloric system is temperature. But whether the "chosen one" be temperature, heat, rate of heat flow, or some other variable, once that one concept is defined and a unit agreed upon to express size in the system, all other concepts in that system can be expressed in terms of it and the three fundamental concepts of mass, length, and time.

12. Brightness.—Those systems in which a fourth concept is recognized are surveyed in the preceding article. The contention of this text is that the illumination system lends itself to a systematization in exactly the same manner as these other systems, with brightness occupying the position of the fourth fundamental concept from which all other concepts in the system can best be defined.

In the early history of illumination, a choice was made of the concept of intensity of a *complete* source, the unit candle, for the basic idea of the system. With this as a start all other concepts and their units were defined in terms of the candle. The choice was logical, in that sources of that period were candle flames or, later, incandescent lamps having spectroradiometric functions and geometrical sizes differing not greatly from those of candle flames.

With advances in the science of illumination toward larger sources and sources having radically different spectroradiometric functions from those of candle flames or incandescent lamps, the limitations of the earlier approach have become increasingly evident. Consequently the international bodies concerned with standards, previous to 1937, had already agreed that the use of the luminosity factors, formerly called *visibility factors*, was the only method of heterochromatic photometry that could be generally accepted, and that the primary standard of light should be the black-body radiator at the temperature of solidification of platinum.

In order to fix the values of all the units, it remained only to agree upon a numerical value for some property of the primary black-body standard. That property, chosen by the International Committee on Weights and Measures, is the *brightness* of the black-body radiator. This alone seems sufficient evidence that the concept of brightness has an important place in the system of illumination.

But, to carry the point one step further, the idea of the luminosity function itself is based upon the concept of brightness. In fact the whole process of seeing is dependent upon the concept of brightness. The test upon which the luminosity function is based was a physiological and psychological test in which the observer made a decision as to one of the attributes of the sensation of color—brilliance. Color is a subjective function, being

determined by each individual through his psychological processes and his physiological nervous system. Measurements upon subjective functions have been and probably will remain in a very hazy, indefinite state because they depend upon individuals.

Brightness, however, need not have any such state of indefiniteness associated with it. Brightness can be defined as an objective quantity and as such can be handled in the same manner as we treat length, mass, and time. For example, a nonselective surface irradiated with a homogeneous irradiation at 0.640μ wave length having a power density of, say, 0.00954 watt per square centimeter would have exactly the same brightness as an identical surface when irradiated with a homogeneous irradiation at 0.540μ wave length of 0.00175 watt per square centimeter, although some observers might judge them to be equally brilliant, others judge the one having the 0.640μ wave-length irradiation more brilliant, and still others judge the reverse to be true.

True, their relative brightnesses are dependent upon a series of tests of the sensation of brilliance, but an agreement has been made that the final recommendations from these tests shall be the basis for treating spectrophotometric phenomena. No matter how perfect or imperfect these tests were or how representative the observers, the accepted luminosity function fixes all relative values of any quantity in the illumination system as influenced by the wave length of the particular quantity involved.

13. Luminous Sources.—A source capable of producing the sensation of brilliance is said to be *luminous*. In turn this source possesses the property of brightness. Brightness can be considered as an inherent property of every element of a luminous source. It is the cause, and illumination is the result. In the classical (so called for want of a better name) photometric system a complete source was interpreted as the cause. In this treatment the brightness of each infinitesimal element of the surface will be treated as the source. In those cases where the source lends itself to a treatment as a whole within the range of engineering accuracy, the classical results will be derived from the results of this text.

Other concepts and the units for them and for brightness will be considered in Chap. 4.

Problems

1.3. Justify the statement on page 22 that "a nonselective surface irradiated with a homogeneous irradiation at 0.640μ wave length having a power density of, say, 0.00954 watt per square centimeter would have exactly the same brightness as an identical surface [observed in the same manner] when irradiated with a homogeneous irradiation at 0.540μ wave length of 0.00175 watt per square centimeter."

REFERENCES

- A. E. Kennelly, The Adoption of the Giorgi MKS Absolute System of Practical Units by the International Electrotechnical Commission, *Trans. Illum. Eng. Soc. (N.Y.)*, **31**, 1936, pp. 685-693.
- J. W. T. Walsh, The New Unit of Light, *Light and Lighting*, June, 1940, p. 96.

CHAPTER 4

ENTITIES IN THE ILLUMINATION SYSTEM AND THEIR UNITS

<i>Symbol</i>	<i>Term</i>	<i>Definition</i>
<i>E</i>	Illumina- tion	Radiant-power density <i>incident</i> upon a receiving surface evaluated in terms of the luminosity function. (Typical unit, lumens per square foot.)
<i>I</i>	Intensity	That property of a <i>complete</i> radiating source which specifies its ability as a whole to produce luminous effects. (Unit, candles.)
<i>B</i>	Brightness	The objective stimulus evoking the sensation of brilliance. The objective stimulus in turn is that property of a radiating source which specifies the ability of an element of the source to produce luminous effects. (Typical unit, candles per square foot of projected area.)
ϕ	Luminous flux	Radiant power evaluated in terms of the luminosity function. (Unit, lumens.)
<i>L</i>	Luminosity	Radiant-power density <i>emitted, transmitted, or reflected</i> evaluated in terms of the luminosity function. (Typical unit, lumens per square foot.)

14. General.—A short review of the ideas discussed in the first three chapters will probably be in order before proceeding to the various entities in the illumination system and their units.

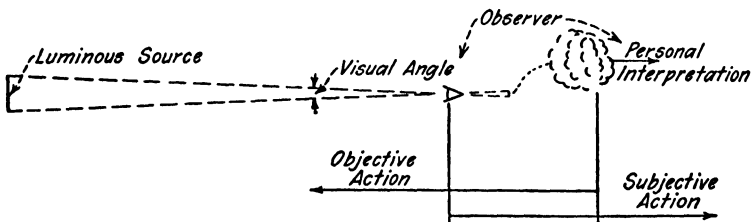

FIG. 12.—Elements of the seeing process.

Referring to Fig. 12, note that the seeing process can be treated from an energy viewpoint as follows: A luminous source emits energy in the direction of an observer. At the observer there will be a certain density of radiant energy in some interval of

time, or, more simply, a density of radiant power. Through the mechanism of the iris of the eye the effect of this radiant-power density then is carried into the eye and on to the retina. From there the nervous system carries the stimuli to the brain, and the brain interprets the results to the consciousness of the individual. The dividing line between the objective and the subjective is not strictly definite. Certainly outside the iris of the eye the energy action is objective; and the final step of interpretation by the individual's brain is probably purely subjective. In the intermediate field there is probably both objective and subjective action.

The physical entities to be developed now are quantities outside the consciousness of the human observer, but they are to be evaluated in terms of a standard, fictitious observer, *i.e.*, the luminosity function.

Whether or not the result of this evaluation tinges the entities with the subjective is perhaps a debatable question. Sources, the geometry of the sources with respect to the receiver, radiant-power densities, etc., could be carried through on a purely objective plane with the luminosity function brought in only at the terminal point of the receiver. However, such has not been the philosophy of those working in optics in the past, and there seems to be no justification in going to this extreme. Rather, the whole system will be evaluated through the luminosity function, and all entities will be considered as purely objective within themselves. However, the student should appreciate throughout the true meaning of the luminosity function and its method of derivation.

15. Illumination.—Illumination is density of radiant power incident upon a receiving surface evaluated in terms of the luminosity function; *i.e.*,

$$E = k \sum_i^n v_i G_i \quad (6)$$

for a line-spectrum irradiation,

where E = illumination.

G_i = irradiation due to the i th component.

v_i = relative visibility at a wave length corresponding to the wave length of the i th component of irradiation.

n = number of component radiations.

k = a constant depending upon the units of the preceding variables.

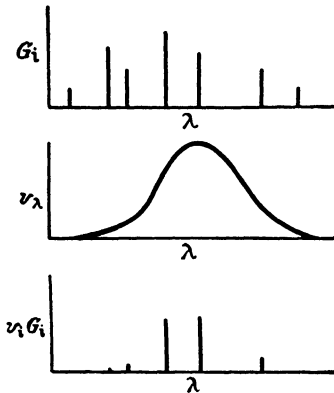

FIG. 13.—Evaluation of illumination from a line-spectrum source through the luminosity function.

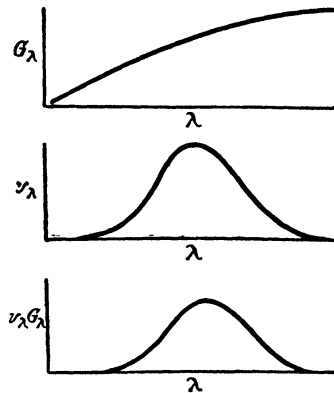

FIG. 14.—Evaluation of illumination from a continuous-spectrum source through the luminosity function. (Area of lower curve = illumination.)

For a continuous spectrum source the summation process is replaced by an integration process, as

$$E = k \int_0^{\infty} v_{\lambda} G_{\lambda} d\lambda \quad (7)$$

where E = illumination.

G_{λ} = special irradiation at λ wave length.

v_{λ} = relative visibility at the corresponding wave lengths.

With the luminosity function agreed upon, the two preceding expressions *could* be utilized for an evaluation of a unit of illumination, thus fixing all other units in the system. This method has been suggested by Professor Moon in "The Scientific Basis of Illuminating Engineering." The procedure places the emphasis upon physical measurements, using the luminosity function as a purely objective function with little or no consideration as to the manner of its derivation. The name of the unit proposed by Moon for the illumination thus defined is the *lightwatt per unit of area*.

However, the governing bodies have not seen fit to follow this procedure in fixing the new system of units for the photometric concepts. Instead they have placed the emphasis upon the brightness of a luminous source. True, the measurement of that

property (the brightness) is made indirectly; *i.e.*, it is made through a measurement of a result—the result being the illumination. Such a procedure is not foreign to students in electrical engineering. The whole concept of a unit charge is based upon a similar foundation. One does not measure a charge; one measures a result. In the static system, this is a force action between two charged bodies. Incidentally one obtains an inverse square law with distance for this phenomenon. An inverse square law enters between cause and effect in the illumination system.

The naming of the unit of illumination and fixing the proportionality constant k of equations (6) and (7) will be reserved until the interrelations of the other various functions in the illumination system have been discussed.

16. Intensity.—Because of the historical past of illumination entities, the concept of the intensity of a *complete* source persists in our literature and nomenclature today. It is carried over even into the name of the unit of brightness. Therefore this discussion on intensity precedes that on brightness.

Intensity can be called that property of a *complete* radiating source which specifies its ability as a whole to produce luminous effects. To treat a source as a whole is possible only under the limited restrictions that the dimensions of the source must be small with respect to the distance at which the effect is determined. Early experiments on illumination comparisons resulting from small sources (originally candle flames) indicated that the illumination decreased inversely as the distance from the source. The property of the complete source that specified its ability to produce the effect (the illumination) was called its *intensity*; and the name of the unit assigned to this property was logically enough the *candle*. Expressing the relationship between the intensity of the source and the illumination upon a plane perpendicular to the source as a function of the distance from the source to the receiver yielded the inverse square law of illumination

$$E = \frac{I}{D^2} \quad (8)$$

where I = intensity of the source, in *candles*.

D = distance from the source to the perpendicular receiving plane, in *feet*.

E = illumination, in the hybrid name of *foot-candles*.

If the receiving plane be at other than the normal to the line of action with the source, a cosine function of the angle β between the normal to the surface and the line of action should be inserted, giving

$$E = \frac{I}{D^2} \cos \beta \quad (8a)$$

Since illumination is density of radiant power evaluated as described in Art. 15, justification for the cosine function can be

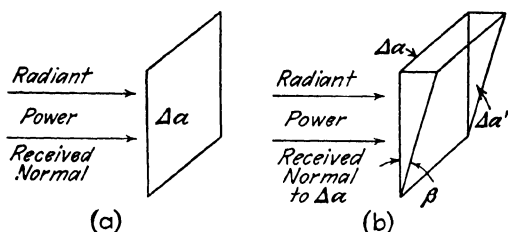

FIG. 15.—The cosine law of illumination.

placed on a geometric basis. For example, consider an area Δa receiving radiant power perpendicular to its surface as in Fig. 15(a). If the same radiant power is distributed over another area $\Delta a'$, as of Fig. 15(b), the density of the radiant power will be reduced inversely as the area is increased, since $\Delta a' \cos \beta = \Delta a$. Hence the general form of the foregoing equation is justified.

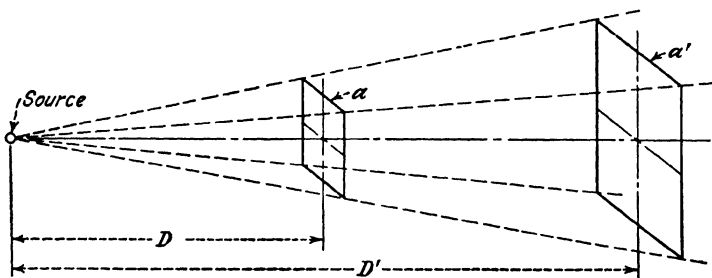

FIG. 16.—Inverse square relationship of illumination and distance from a small source.

Let us now return to the restriction previously mentioned that the dimensions of the source must be small with respect to the distance at which the illumination is determined if the source is to be treated as a whole. On the premise that radiant power travels only in straight lines through a homogeneous medium, it is evi-

dent that, if the source is taken as a very small body, the areas of Fig. 16 will be directly proportional to the square of the distance from the source to the center of the areas. If there is no absorption of radiant power in the medium through which it passes, the radiant power upon area a would be identical with that upon area a' if area a is nonabsorbing. Consequently, the radiant-power density and the illumination will vary inversely as the square of the distance D . All this has been based upon the dimensions of the source being small with respect to D . Now if the source is increased in size, the *minimum* D considered must be fixed correspondingly larger.

Consider equation (8a) again.

$$E = \frac{I}{D^2} \cos \beta \quad (8a)$$

If this equation is solved for the intensity, then

$$I = \frac{ED^2}{\cos \beta} \quad (8b)$$

To fix the restriction that D must be large with respect to the dimensions of the source, an operational definition of intensity could be expressed as

$$I = \lim_{D \rightarrow \infty} \frac{ED^2}{\cos \beta} \quad (9)$$

To illustrate the meaning of this form of the relationship, consider a set of data for a particular source that is *not* small with respect to the smaller values of D as given. All measurements of illumination are made along the same line of action from the source and upon a surface having its normal directly along the line of action (*i.e.*, $\cos \beta = 1.00$). The data and calculations of ED^2 are given in Table 1. Note that at small values of distance the product ED^2 gives an *apparent* intensity much smaller than at larger values of D . Note that an increase in L from 10 to 15 ft. gives ED^2 an increase of only 10 candles. Therefore the inverse-square-law relationship holds reasonably well in this range and beyond; whereas in the range much below 10 ft. the law loses all semblance of meaning.

Naturally the limit of $ED^2/\cos \beta$ as D approaches infinity must be finite if the source as a whole is to have a finite intensity.

TABLE 1.—DATA ON ILLUMINATION ON A NORMAL SURFACE AS A FUNCTION OF DISTANCE FROM A PARTICULAR SOURCE

D , ft.	E , ft.-candles	ED^2
0.5	1510	380
1	940	940
2	375	1500
4	111	1780
6	50.9	1830
8	29.0	1860
10	18.7	1870
15	8.34	1880
20	4.70	1880
40	1.18	1880
100	0.188	1880

The term *apparent* intensity as mentioned above is much used in engineering work. The distance at which the evaluation is made should always be expressed, especially if it is less than 10 ft., for sources having maximum dimensions greater than 2 ft., or for even smaller sources if lenses or certain types of reflectors are used. Unfortunately the specification of distance is often omitted. When this is omitted, the remaining data on intensity may have practically no meaning.

So much for the geometrical limitations of the original idea of intensity of a complete source.

The student should note that naming of some units for intensity and for illumination has not yet rigorously fixed the size of these units. In the past, when the difference in the spectroradiometric distribution of energy from sources was small, the fixing of size of units was accomplished by specifying the dimensions and materials of a standard candle. With the advent of incandescent lamps the standards were reestablished by agreement. The new standards were set by various incandescent lamps in the standards laboratories of the several countries involved in maintaining the standards. More recently with the development of electric-discharge lamps and indirect-lighting methods and more use of color in the application of lighting, the need has arisen for the establishment of a precise system of specifying and maintaining a new standard. This new standard would not have the limitations of

geometrical size with respect to the distances at which its resulting illumination would be evaluated, nor would it be limited spectroradiometrically.

17. Brightness.—Consider a luminous source having a surface of any continuous configuration. Instead of treating the source as a whole and specifying its true luminous effectiveness through an effect at a great distance, let us fix our attention upon a small

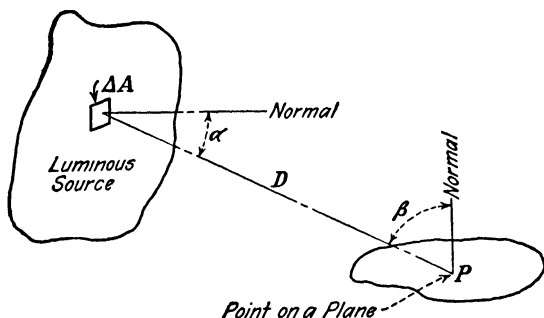

FIG. 17.—The geometry of the cause-and-effect variables in evaluating illumination.

element of the surface of area ΔA , which is sufficiently small for the element to be considered plane. ΔI designates the intensity of the element in some particular direction at an angle of α with the normal to the element. The relationship between cause and effect would be (following the reasoning of the inverse square relationship previously discussed)

$$\Delta E_P = \frac{\Delta I}{D^2} \cos \beta \quad (10)$$

or

$$\Delta I = \frac{D^2 \Delta E_P}{\cos \beta} \quad (10a)$$

where ΔE_P = element of illumination at a point P on a plane whose normal is at an angle β with the line of action.

ΔI = intensity of the element of area ΔA in the direction of P , and α is the angle with the normal.

D = distance from element to the point at which the illumination is evaluated.

Again the restriction must be applied that the distance D must be great with respect to the dimension of ΔA . Now, however, instead of specifying that the distance D shall be made larger and larger until a limiting evaluation is approached, let us shrink the

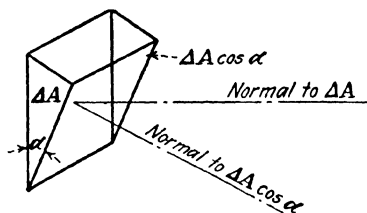

FIG. 18.—Element of area of a luminous source and its projected area.

element ΔA in area to accomplish the relative increase in D . If the area is to be shrunk to its limiting value of zero, we shall be evaluating some property at a point on the luminous surface. ΔA does not appear in equation (10) or (10a). Obviously it is desirable that the area of the element appear in the expressions

before the limit is evaluated. Certainly dividing both sides of equation (10a) by the projected area of the element when viewed along the line of action at angle α will not change the validity of the expression.

This division yields

$$\frac{\Delta I}{\Delta A \cos \alpha} = \frac{D^2 \Delta E_P}{\Delta A \cos \alpha \cos \beta} \quad (11)$$

Now shrink the area of the element to zero. ΔI approaches zero as ΔA approaches zero; and likewise ΔE_P (the element of illumination at the point P) approaches zero as ΔA goes to zero. The limit of the expression on the left side of the equality sign is

$$\text{Limit}_{\Delta A \rightarrow 0} \frac{\Delta I}{\Delta A \cos \alpha} = \frac{1}{\cos \alpha} \frac{dI}{dA} \quad (12)$$

whereas the limit of the right-hand side is

$$\text{Limit}_{\Delta A \rightarrow 0} \frac{D^2 \Delta E_P}{\Delta A \cos \alpha \cos \beta} = \frac{D^2}{\cos \alpha \cos \beta} \frac{dE_P}{dA} \quad (13)$$

and these two limits are identical, so

$$\frac{1}{\cos \alpha} \frac{dI}{dA} = \frac{D^2}{\cos \alpha \cos \beta} \frac{dE_P}{dA} \quad (14)$$

A picture of what is represented by the left-hand side of this equation can be obtained by considering Fig. 19. To simplify the diagram, the point of view is normal to the surface so that $\cos \alpha = 1.00$. Consider first an element of area ΔA whose intensity in the direction of the observer is ΔI . The ratio of $\Delta I/\Delta A$ ($\cos \alpha$ being 1.00) could be called the average density of the intensity of the source over the area ΔA . Actually this

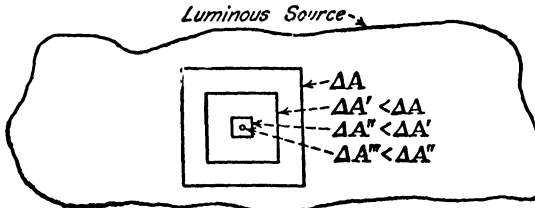

FIG. 19.—Shrinking the element ΔA .

average density of the intensity is simply the average *brightness* of the element of area ΔA .

If the distribution of energy from the element of area ΔA is uniform over the surface, and if it is distributed identically, both spectroradiometrically and geometrically, from every part of the surface, then the average density is the same as that at every point on the surface. If the distribution is not uniform, then it is necessary to reduce the area to a smaller area $\Delta A'$, whose intensity is $\Delta I'$. If this reduction eliminates the nonuniformity, then the average gives the value at every point. If it does not, then a further reduction to $\Delta A''$ and the corresponding $\Delta I''$ is necessary, etc. Eventually the area and likewise the intensity may be made infinitely small. The limit as ΔA approaches zero relates the brightness at the point of shrinkage in the direction of the observer to the intensity. Thus

$$B = \frac{1}{\cos \alpha} \frac{dI}{dA} \quad (15)$$

where B = brightness at a point on a luminous source in the direction at an angle α with the normal.

Note that equation (15) treats only of the source and relates brightness and intensity. Now consider the right-hand form of the equality (14) which contains terms relating to both the cause

and the effect,

$$B = \frac{D^2}{\cos \alpha \cos \beta} \frac{dE_P}{dA} \quad (16)$$

Solving for dE_P ,

$$dE_P = \frac{B}{D^2} \cos \beta \cos \alpha dA \quad (16a)$$

This gives the differential amount of illumination at P due to the differential projected area ($\cos \alpha dA$) in the direction of P , *i.e.*, the area effective in producing an illumination at P . If the receiving plane is perpendicular to the distance P ($\cos \beta = 1.00$), then the differential illumination at P is a maximum for a given differential source; whereas if the plane of the receiver is turned through an angle β , the differential illumination varies directly with the $\cos \beta$. The D enters as the inverse square for reasons already considered and pictured in Fig. 16. The linear relationship between the cause B and effect dE_P can be justified from an energy viewpoint. In fact it is upon this foundation of linearity that the concept of the intensity and the resulting brightness as a limiting value of $\Delta I / (\cos \alpha \Delta A)$ was based.

Since equation (16a) considers the effect at P caused only by a differential area of the source, the illumination at P from a complete source S can be found by integrating over the area of the source that is visible from the point P . If B takes on different values as α changes and/or as the position of the element changes, the brightness is a variable of the integration and must be considered in the integrand. This gives the general equation for illumination.

$$E_P = \int_s \frac{B}{D^2} \cos \beta \cos \alpha dA \quad (17)$$

The \int_s indicates a surface integration over all the luminous surface which is visible from the point P .

Consider a source of finite dimensions (as all sources are) that has dimensions *small* with respect to the distance from any point on the source to the point P at which the illumination is to be evaluated. As the element of area dA takes on positions over the

surface S , note that the angle β changes only slightly. Hence $\cos \beta$ for the integration process is very nearly constant. Like-

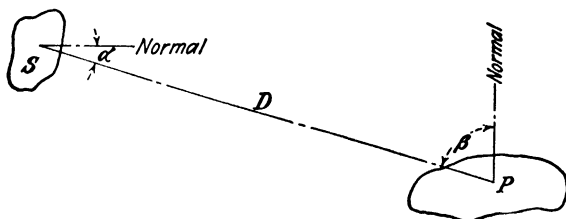

FIG. 20.—A small source S at a large distance D .

wise the distance D from the element dA to P changes only slightly and likewise is nearly constant. Hence an approximate solution of the integration would be

$$E_p \cong \frac{\cos \beta}{D^2} \int_s B \cos \alpha \, dA \tag{18}$$

Previously, in equation (15), brightness and intensity were related through

$$B = \frac{1}{\cos \alpha} \frac{dI}{dA} \tag{15}$$

Separating variables of equation (15) gives

$$dI = B \cos \alpha \, dA \tag{19}$$

or, integrating over the surface S ,

$$\int_s dI = \int_s B \cos \alpha \, dA \tag{20}$$

Now by $\int_s dI$ is meant simply a summation of the elementary intensities of all the elements of the surface S . Consequently the summation process yields the intensity of the source as a whole from the large distance D in the direction of the point P . With this substitution,

$$\int_s dI = I = \int_s B \cos \alpha \, dA \tag{21}$$

in equation (18) we are logically enough right back at the inverse square law for a complete source.

$$E_p \cong \frac{I}{D^2} \cos \beta \tag{8}$$

Considering the right-hand side of equation (21), note that the integration of $B \cos \alpha dA$ over the surface visible from the point in question is simply the brightness integrated over the projected area of the source. Now, *if the brightness is constant over the surface,*

$$I = B \int_S \cos \alpha dA \quad (22)$$

Since the integral is simply the projected area of the source from P , the brightness of a source of uniform brightness can be related to the intensity as

$$B = \frac{I}{\text{projected area of source}} \quad (23)$$

The average brightness of the source is obtained if the brightness over the surface is not uniform.

With the name *candle* assigned to the concept of intensity for many years, an appraisal of the dimensions of equation (23) shows why the name assigned to the unit of brightness is the *candle per unit area* of the source.

Inasmuch as it is possible to eliminate the concept of intensity of the complete source from the cause-and-effect relationships [equation (17)], it would be possible to assign to the unit of brightness a name that is completely foreign to a candle or to any other unit of intensity. However such has not been done, and there is no reason why such a procedure is necessary. It is quite logical that a unit of brightness be a *candle per square centimeter*, a *candle per square inch*, or a *candle per square foot*, etc.

At the time the committees of the International Conference on Weights and Measures were considering the adoption of the MKS or Giorgi system of electromagnetic units, the committee on illumination recommended that by international agreement the brightness of a black-body radiator at the temperature of solidification of platinum, 2046°K., when viewed normal to the surface should be fixed at 60 candles per square centimeter. All other units in the system would be fixed in size by this agreement. The new units were to have been put into effect Jan. 1, 1940.

The temperature of the solidification of platinum was chosen because this definitely specifies the temperature in a manner that can be reestablished in any laboratory. On the basis of the old

system of units such a source gave a brightness of approximately 58.8 candles per square centimeter as determined by laboratories in England, Germany, France, and the United States. In establishing the new units a choice of a full decimal number of 60 was made. The property of brightness of a source having a definite spectroradiometric distribution is thus established. For sources of different spectral distribution the luminosity function must be applied to the variable under consideration.

Because of the present war very little has been done in putting into effect any international system of units. Consequently the size of our units in the illumination system have not been changed as yet. Our national system is still maintained by certain incandescent lamps at our National Bureau of Standards. The constant 621, given on pages 43 and 44, will be 633 if the proposed system is ever finally placed in effect.

Consider a black-body radiator at 2046°K. as a luminous source. The illumination at some point P on a plane would be specified in magnitude by

$$E_P = \int_S \frac{B}{D^2} \cos \beta \cos \alpha dA \quad (17)$$

However, this alone would not *completely* specify the illumination. It would give only its magnitude. An appraisal spectroradiometrically is also necessary as in Fig. 14, where the area of the $v_\lambda G_\lambda$ vs. λ curve is also the magnitude as determined above. Thus it becomes apparent that in illumination one works with a great number of variables or specifications. The cause and effect relationships are both geometric relationships, as equation (17), and spectro-relationships, as partially indicated in Figs. 13 or 14. The figures treat conditions only at the receiver. A similar procedure at the source would be possible. However, no concept in the power-radiation system bears the same relationship to brightness as incident power density at the receiver bears to illumination. A critical survey of the radiation system might indicate, however, a real need for such a concept.

The integration process, using brightness in candles per unit of area and $\cos \alpha dA$ (projected area of the element) in the same units of area, is simply the inverse square law more precisely stated for all conditions. Hence the name of the unit for illumination, the *foot-candle*, can still be used. When this term is so

used, the distance D must be measured in feet. However the brightness and area of the source need not be expressed in this same dimension of length. But the dimension used for one must be used for the other. For example, if brightness is expressed in candles per square centimeter, then dA must be expressed in square centimeters. At the same time E_P could be in foot-candles and D in feet.

Before proceeding to any other concepts, a slightly different viewpoint on equation (16) may be useful. In the classical system embodying a fictitious "point" source, a great many of the so-called definitions of the standards committees deal with solid angles extending outward from the point source. Such angles from actual physical luminous sources (which always have finite size) are extremely difficult if not impossible to imagine. Therefore the mere mention of a solid angle to many individuals working in illumination tends to suggest a "something" having no absolute physical meaning. Certain solid angles, however, do have definite meanings in illumination phenomena. A solid angle such as that which a source (either finite or incremental) subtends when viewed from a point at which the illumination is to be determined will be considered. Such a solid angle is illustrated in Fig. 21, where $\Delta\omega$ is the solid angle that the incremental

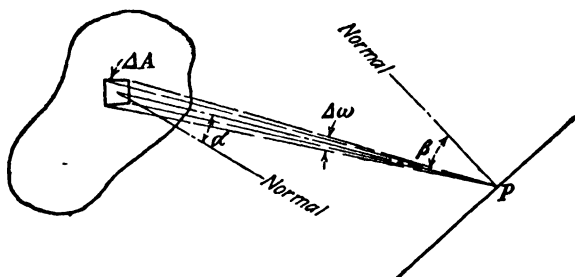

FIG. 21.—Solid angle subtended by a source.

area ΔA subtends when viewed from the point P on the receiving plane. The apex of the angle is at a point, and the angle is determined by the incremental area of the source projected upon a sphere whose center is at P and whose radius is any convenient value D .

Let the value of D be chosen so that the sphere passes through the incremental area at its point of shrinkage as ΔA approaches zero. In the differential form then

$$d\omega = \frac{dA \cos \alpha}{D^2} \quad (24)$$

where α is the angle between the normal to the actual surface at the point of shrinkage of ΔA and the radial distance D .

A substitution into equation (16) gives

$$B = \frac{1}{\cos \beta} \frac{dE_p}{d\omega} \quad (25)$$

If dE_n is designated as the normal component of the elementary illumination at point P , then when the receiving surface is at an angle β (as in the illustration), the relationship between dE_n and dE_p is

$$dE_p = dE_n \cos \beta \quad (26)$$

A substitution in equation (25) gives

$$B = \frac{dE_n}{d\omega} \quad (27)$$

This expression is in its differential form. Expanding to include the incremental form,

$$B_{\text{avg.}} = \frac{\Delta E_n}{\Delta \omega} \quad (28)$$

Thus the average brightness of a finite source (or portion of a source) may be approximately determined by the ratio of the illumination upon a surface normal to the source at its center to the solid angle subtended by the source. The smaller the portion of the source considered the better will be the approximation. This expression is extremely useful in determining the brightness of a source that is not a simple surface. One example of such a source is the sky. There is no meaning to sky brightness on the basis of intensity per unit area. A specification of the distance at which an area should be evaluated is extremely difficult to imagine. Even if this can be imagined, how does one arrive at the intensity of such a source? Another application of this form of cause-and-effect relationship is to the brightness of a gaseous discharge column where the surface of the arc stream may be difficult if not impossible to determine.

18. Luminous Flux.—Consideration has been taken at several points that illumination is density of radiant power incident

upon a receiver plane evaluated through the luminosity function. Then illumination can be treated as a density of some concept in the illumination system. That concept is called *luminous flux* and is radiant power evaluated in terms of the luminosity function. Consider the illumination to be constant at every point on an area Δa . The flux received by the area then would be

$$\Delta\phi_R = E \Delta a \quad (29)$$

where $\Delta\phi_R$ = flux received by the receiving area Δa .

E = illumination at every point on ΔA .

Solving for E ,

$$E = \frac{\Delta\phi_R}{\Delta a} \quad (30)$$

If the illumination is not the same at every point on the surface, then the ratio of the flux to the area yields the average illumination of the area.

Considering equation (30), it is apparent that there is very little dimensional meaning to the hybrid name *foot-candle* which has been handed down to us. The name given to the unit of luminous flux is the *lumen*. Consequently a logical unit of illumination, if the area Δa is expressed in square feet, is the *lumen per square foot*. One lumen per square foot and one foot-candle are numerically the same.

Referring again to equation (30), a limit as the element of area of the receiver approaches zero can be taken if the flux is not distributed uniformly over the area. This is the same procedure as was followed in specifying the brightness at a point on a luminous source.

$$E = \frac{d\phi_R}{da} \quad (31)$$

This relationship specifies the illumination at a point on a receiving surface in terms of the flux conditions in the immediate vicinity of the point under consideration.

19. Light.—Light is radiant energy evaluated according to its capacity to produce visual sensation. Expressed mathematically for a continuous spectrum source

$$Q = k \int_0^\infty v_\lambda W_\lambda d\lambda \quad (32)$$

where Q = quantity of light.

v_λ = relative visibility at λ wave length.

W_λ = spectral radiant energy at λ wave length.

λ = wave length.

k = constant depending upon the units used.

For a line-spectrum source

$$Q = k \sum v_i W_i \quad (33)$$

where W_i = radiant energy at the wave lengths at which radiation is accomplished by the source.

v_i = relative visibility at the corresponding wave lengths.

k = constant depending upon the units used.

20. Luminosity.—One further concept in the illumination system is convenient. In considering a source of luminous flux (which has been considered to the present in terms of its intensity or brightness) the density of luminous flux *leaving* the surface is often of interest. Thus a relationship very similar to equation (30) can be defined as the *luminosity* of the source,

$$L = \frac{\Delta\phi_E}{\Delta A} \quad (34)$$

where L = luminosity of the source.

$\Delta\phi_E$ = luminous flux leaving the area ΔA .

If $\Delta\phi_E$ is expressed in lumens and ΔA in square feet, the dimensional unit for the luminosity is the same as that for illumination, the *lumen per square foot*. As an analogy to the hybrid name of *foot-candle* as another unit of illumination, the corresponding term for luminosity is a *foot-lambert*. Again one lumen per square foot for emitted flux is numerically equal to one foot-lambert.

Luminosity is a property of the source at a specified point on the surface. If the luminosity is not uniform over the area ΔA , equation (34) gives the average luminosity of the area. Strictly then,

$$L = \frac{d\phi_E}{dA} \quad (35)$$

Very, very much confusion has arisen through an attempt on the part of the standards committees to combine brightness and

luminosity under the one name *brightness*. Brightness and luminosity are two radically different entities. Let us review the ideas of each.

Consider a differential element of a luminous source dA . The brightness of the source at the position of dA in *some one* particular direction is related to a differential illumination at a point on a plane through equation (16). The point P is on the same line of action as that for which B is specified.

$$B = \frac{D^2}{\cos \alpha \cos \beta} \frac{dE_P}{dA} \quad (16)$$

Note that the brightness thus expressed is that *only* in the direction of the point P . The brightness of the *same* point on the luminous source in some *other* direction than that toward P is not even considered. It may be the same as that toward P ; it may be different. Whatever it is has no influence on the effect at P .

Now consider this same element of the source with respect to its luminosity. From the element a differential amount of luminous flux $d\phi_E$ is emitted. This flux may be leaving the source in a certain cone (or solid angle), or it may be distributed in all possible directions. The consideration has *not* centered upon any particular direction. In general, therefore, the luminosity cannot specify the ability of the differential element to produce an effect at any certain point in space, whereas the brightness does specify this ability. Conversely the brightness in some one direction cannot specify the amount of flux *leaving* the element.

No attempt is made here to justify the logic of the standards committees in attempting to group brightness and luminosity (as herein defined) under the same name brightness. The principal divergence of nomenclature in this text from the nomenclature established by the Illuminating Engineering Society and the American Standards Association is the inclusion of the term *luminosity*.

In the literature dealing with illumination one often encounters the term *brightness* expressed in foot-lamberts (lumens per square foot). If this term is interpreted as luminosity and treated as such, the idea intended to be conveyed by the writer is usually apparent.

21. Summary of Entities and Units in the Illumination and the Radiation Systems.—Table 2 outlines the principal entities in the illumination system with a typical unit and also gives the analogous concept in the radiation system.

TABLE 2.—ENTITIES AND UNITS IN THE ILLUMINATION AND THE RADIATION SYSTEMS

Illumination system			Radiation system		
Symbol	Concept	Typical unit	Symbol	Concept	Typical unit
<i>B</i>	Brightness	Candle/sq. ft.	..	None	
<i>I</i>	Intensity	Candle	..	None	
ϕ	Luminous flux	Lumen	<i>P</i>	Radiant power	Watt
<i>Q</i>	Light	Lumen-second	<i>W</i>	Radiant energy	Joule
<i>L</i>	Luminosity	Lumen/sq. ft.	<i>J</i>	Emission	Watt/sq. ft.
<i>E</i>	Illumination	Lumen/sq. ft.	<i>G</i>	Irradiation	Watt/sq. ft.

A summary of the interrelations among these entities is made below. The spectroradiometric conversions are presented first. The constant of 621 lumens per watt is the same constant as the *k* of equations (6) and (7). One watt of homogeneous power at 0.55μ wave length yields 621 lumens of flux. Power at other wave lengths is less effective; hence the v_i or v_λ of the following eight equalities.

For a line-spectrum source:

$$Q \text{ (lumen-seconds)} = 621 \left(\frac{\text{lumens}}{\text{watt}} \right) \sum_1^n v_i \text{ (pure number)}$$

$$W_i \text{ (joules)} \quad (36)$$

$$\phi \text{ (lumens)} = 621 \left(\frac{\text{lumens}}{\text{watt}} \right) \sum_1^n v_i \text{ (pure number)}$$

$$P_i \text{ (watts)} \quad (37)$$

$$L \text{ (lumens/sq. ft.)} = 621 \left(\frac{\text{lumens}}{\text{watt}} \right) \sum_1^n v_i \text{ (pure number)}$$

$$J_i \text{ (watts/sq. ft.)} \quad (38)$$

$$E \text{ (lumens/sq. ft.)} = 621 \left(\frac{\text{lumens}}{\text{watt}} \right) \sum_1^n v_i \text{ (pure number)}$$

$$G_i \text{ (watts/sq. ft.)} \quad (39)$$

For a continuous-spectrum source:

$$Q \text{ (lumen-seconds)} = 621 \left(\frac{\text{lumens}}{\text{watt}} \right) \int_0^{\infty} v_{\lambda} \text{ (pure number)} \\ W_{\lambda} \text{ (joules/micron)} d\lambda \text{ (micron)} \quad (36a)$$

$$\phi \text{ (lumens)} = 621 \left(\frac{\text{lumens}}{\text{watt}} \right) \int_0^{\infty} v_{\lambda} \text{ (pure number)} \\ P_{\lambda} \text{ (watts/micron)} d\lambda \text{ (micron)} \quad (37a)$$

$$L \text{ (lumens/sq. ft.)} = 621 \left(\frac{\text{lumens}}{\text{watt}} \right) \int_0^{\infty} v_{\lambda} \text{ (pure number)} \\ J_{\lambda} \text{ (watts/sq. ft. per micron)} d\lambda \text{ (micron)} \quad (38a)$$

$$E \text{ (lumens/sq. ft.)} = 621 \left(\frac{\text{lumens}}{\text{watt}} \right) \int_0^{\infty} v_{\lambda} \text{ (pure number)} \\ G_{\lambda} \text{ (watts/sq. ft. per micron)} d\lambda \text{ (micron)} \quad (39a)$$

The interrelations of the illumination system entities *at the source only* are next summarized.

$$B \text{ (candles/sq. ft.)} = \frac{1}{\cos \alpha} \text{ (pure number)} \frac{dI \text{ (candles)}}{dA \text{ (sq. ft.)}} \quad (40)$$

$$L \text{ (lumens/sq. ft.)} = \frac{d\phi_E \text{ (lumens)}}{dA \text{ (sq. ft.)}} \quad (41)$$

The interrelations of the illumination system entities *at the receiver plane only* are as follows:

$$E \text{ (lumens/sq. ft.)} = \frac{d\phi_R \text{ (lumens)}}{dA \text{ (sq. ft.)}} \quad (42)$$

The general interrelation between entities at the source and at the receiver plane is

$$B \text{ (candles/sq. ft.)} = \frac{D^2 \text{ (ft.}^2\text{)}}{\cos \alpha \cos \beta \text{ (pure numbers)}} \frac{dE \left(\frac{\text{lumens}}{\text{sq. ft.}} \right)}{dA \text{ (sq. ft.)}} \quad (43)$$

or

$$B \text{ (candles/sq. ft.)} = \frac{1}{\cos \beta \text{ (pure number)}} \frac{dE \left(\frac{\text{lumens}}{\text{sq. ft.}} \right)}{d\omega \text{ (pure number)}} \quad (43a)$$

It may be noted from the preceding equation that dimensionally a candle and a lumen are the same, since all other dimensions cancel. This dimensional analysis will be considered further in later chapters.

The approximate inverse square law with restrictions as previously discussed at great length is

$$I \text{ (candles)} \cong E \left(\frac{\text{lumens}}{\text{sq. ft.}} \right) D^2 \text{ (ft.}^2\text{)} \frac{1}{\cos \beta} \text{ (pure number)} \quad (44)$$

Problems

1.4. Determine the relative magnitudes of the illuminations from the two mercury-vapor lamps for which data on irradiations are given in Figs. 4 and 5. Consider the larger value as 100 per cent.

2.4. Determine the relative magnitudes of the illuminations from the (a) daylight, (b) red, (c) green, and (d) blue fluorescent lumiline lamps for which data on irradiations are given in Fig. 10. Consider the largest value as 100 per cent. Plot the calculated spectral distributions for the four sources, and measure the areas by planimeter. To show the line-spectrum components graphically on the same sheet with the continuous-spectrum results, two ordinate scales will be expedient—one for the continuous-spectrum curves and one for the line-spectrum results.

3.4. A certain indirect-lighting unit has an apparent intensity (candle power) as measured at 10 ft. at an angle of 72.5 deg. measured from the vertical upright of 1300 candles. What will be the illumination at a point on the ceiling 9 ft. 6½ in. from the center of the support at the ceiling if the hanging height of the center of the fixture is 36 in.?

4.4. If the fixture of Prob. 3.4 were hung with a hanging height of 24 in. would it be possible to obtain the illumination at some point on the ceiling if the apparent intensity distribution at 10 ft. were known for all angles? If so, where would the point be and what would be the illumination in terms of the apparent intensity? If it is not possible, why not?

5.4. A circular plane disk of 1 ft. radius acts as a luminous source. At a great distance along a line perpendicular to the surface and through the center of the disk, the intensity of the disk as a whole is found to be 1880 candles. The distance is so large that an increase in it has no appreciable effect upon the apparent intensity. What is the average brightness of the source?

6.4. If the brightness of the source of problem 5.4 is uniform over the source both as to position on the source and as to angle of observation, set up the relationship between the illumination at a point lying at the intersection of the central axis of the disk source and a plane parallel to the source at a variable distance q . Integrate the expression giving E_p as a function of q . Substitute from 0 to 100 ft. Compare with Table 1.

7.4. What would be the illumination at $q = 1$ ft. in problem 6.4 if the inverse square law of the source as a whole were applied using the true

intensity of 1880 candles? Measure the distance from the center of the source. Compare this with the illumination at $q = 1$ ft. by the integral method.

8.4. A rectangular ceiling coffer of uniform brightness both as to position and angle of observation has dimensions of 6 by 6 ft. A desk is centered under this luminous source at a distance of 7 ft. from the source to the desk. Consider the source as a plane surface. What is the illumination upon the center of the desk?

9.4. If the intensity of the source as a whole (as obtained at a great distance) in Prob. 8.4 were used in the inverse square law, what would be the illumination? Use the distance to the center of the source. Compare the result with that of Prob. 8.4.

10.4. Does the value of illumination at $q = 0$ in Prob. 6.4 bear any relationship to the luminosity of the source at its center? If so, what? If not, why not?

11.4. If the illumination at some point on a particular plane produced by an incandescent lamp operating at 2950°K . is 20 lumens per square foot, and the illumination caused by a "gold" fluorescent lamp at some point on another plane is 10 lumens per square foot, what is the ratio of the irradiations at the respective points?

REFERENCES

- Illuminating Engineering Nomenclature and Photometric Standards, *Am. Standard Assoc.*, 1932.
- W. E. Forsythe, The Present Status of Photometry, *Trans. Illum. Eng. Soc.* (N.Y.), **31**, 1936, p. 181.
- P. Moon, "The Scientific Basis of Illuminating Engineering," McGraw-Hill Book Company, Inc., New York, 1936.
- A. Gershun, The Light Field, *J. Math. Physics*, **18**, 1939, p. 51. (Trans. by Parry Moon and Gregory Timoshenko.)
- J. W. T. Walsh, The New Unit of Light, *Light and Lighting*, June, 1940, p. 96.

CHAPTER 5

MEASUREMENT OF ILLUMINATION

<i>Term</i>	<i>Definition</i>
Illuminometer	An instrument used in measuring illumination.
Photometer	An instrument used in measuring illumination but particularly adapted to a determination of apparent intensity through the illumination thus measured and a conveniently arranged distance scale.
Photoelectric	Any electrical effect due to the influence of radiant energy having a wave length or wave lengths comparable to those wave lengths effective in producing luminous effects.
Sensitivity	Ratio of the effect to the cause—in light-sensitive cells, the current produced per foot-candle of illumination.

22. Visual Comparison Methods.—The eye and the associated nervous mechanism are not capable of *measuring* any phenomenon in the illumination system. The eye can detect whether or not the phenomenon exists but cannot measure it directly. If two fields that are identical in all respects as to magnitude of brightness and to the spectral character of the emission are visible to an observer, that observer can compare the brilliance, hue, and saturation effects that the fields produce and decide that the fields are identical. If the fields have identical spectral character but differ in magnitude of their brightness, the observer can detect a difference in effect or effects and thus know that the fields are not identical. Beyond this rather elementary routine the eye is not capable of functioning.

For example, if the fields possess the same brightness but differ in spectral distribution, the observer is usually in great confusion as to whether or not the fields have the same brightness. Adjustments on the fields can be made until one field is undeniably more brilliant than the other. Adjustments can then be made until the field that was previously less brilliant becomes more brilliant. But to attempt to adjust until the two fields yield the same sensation of brilliance produces results that contain an enormous personal factor if the spectral distribution is not nearly identical.

In the early work in photometry, sources possessed little variation in their spectral qualities. Hence the eye was used as an instrument of comparison for balancing effects. When effects were thus balanced, calculations were made and sizes of other entities were determined.

With the discovery of the spectral nature of radiant energy and the subsequent invention of light sources having spectral qualities of wide variation, the need has increased for measuring instruments of the direct reading type. However, before considering this type of equipment a short description of a visual comparison instrument will be made.

23. Macbeth Illuminometer.—The Macbeth illuminometer differs from other visual comparison illuminometers only in the details of its construction. The principle of operation is identical with that of a bar photometer such as is used in photometric laboratories for visual comparison tests. The principal reason for choosing this illuminometer for discussion is that the equipment as a whole is portable and lends itself to engineering survey use.

In measuring illumination, a test plate is placed at the position and parallel to the plane upon which the illumination is desired. This test plate is made of a white material of good diffusing qualities and hence has essentially constant brightness from all reasonable angles of observation. (The subject of diffusion is treated more fully in Chap. 6.) The test plate therefore acts as a secondary luminous source. The brightness of this plate is compared with the brightness of a translucent screen within the instrument which is illuminated by a small lamp of a known intensity in the direction of the screen. The scale of the instrument is calibrated in foot-candles (or lumens per square foot), and the user standardizes it himself to allow for the absorption of the test plate.

The Macbeth illuminometer consists of three main parts: the illuminometer proper, a controller, and a reference standard, together with various accessories.

The illuminometer is shown in Fig. 22. A Lummer-Brodhun cube is mounted in the rectangular head. (A Lummer-Brodhun cube consists of an optical combination of prisms for viewing two fields that are presented to the eye as two concentric areas.) The photometric fields are viewed through the telescope. The aperture opposite the telescope is aimed at or pointed toward

the test plate or any surface of which the brightness is to be measured. In the tube, which is 9 in. long by 1.75 in. in diameter, is a diaphragmed carriage within which is mounted an incandescent lamp called the *working standard*. The lamp carriage is moved up and down in the tube by means of a rack and pinion operating upon a square rod to which the carriage is fastened. The rod is seen projected from the tube in Fig. 22. On one side of the rod to which the lamp carriage is attached is engraved the scale of the instrument reading from 1 to 25 ft.-candles. An index point is attached to the bottom of the tube.

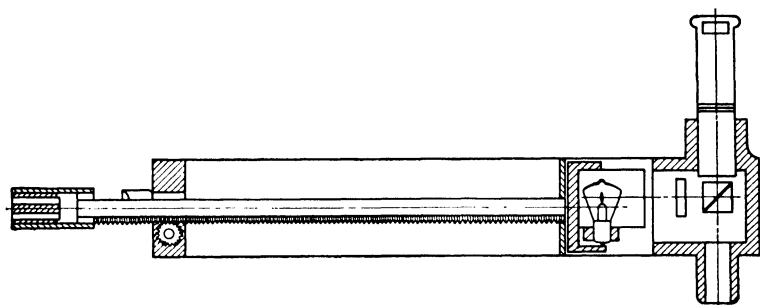

FIG. 22.—Cross section of a Macbeth illuminometer.

The second unit of the equipment is the controller. It is supplied with a shoulder strap for convenience of operation and observation when using the instrument. The controller comprises the battery for operating the lamps; a milliammeter; two close-regulating rheostats, one for the working standard and one for the reference standard lamp; and a double-throw switch, by means of which the milliammeter may be brought into either the working standard circuit or the reference standard circuit. Around the edges of the base are six plug connectors; one of these is for the attachment of the working standard, a second for the attachment of the reference standard, and the four remaining ones for battery connections. The equipment is ordinarily operated from two No. 6 dry cells in series, carried in the leather case fastened to the under part of the controller. When the milliammeter is thrown from one circuit to the other, a resistance is automatically thrown in the circuit from which the milliammeter has been removed, this resistance being just equal to the resistance of the milliammeter, thus avoiding a change of current

through either lamp. The diagram of connections of the controller is shown in Fig. 23.

By using a milliammeter instead of a voltmeter for the control of the lamps, there is no likelihood of error due to changes in contact resistances, the breaking of strands in the flexible cords, and other possible sources of difficulty.

The third element of the illuminometer is the reference standard. A cross section is illustrated in Fig. 24. By the use of the reference standard, the illuminometer may be checked at any time or place, doing away with the necessity of a darkroom and auxiliary photometric apparatus and with the inconvenience and expense of laboratory-standardized working standard lamps

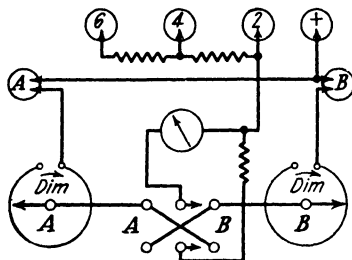

FIG. 23.—Schematic diagram of controller.

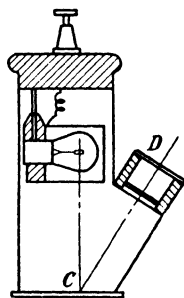

FIG. 24.—Cross section of reference standard.

The ease of frequent calibration permits the use of working standard lamps at a very much higher efficiency than ever attempted before, thus securing better color of light and considerably reducing the current demand and consequent drain on the battery.

The reference standard consists of a metal housing in which is mounted a standardized lamp, fully protected with diaphragm screens. The interior parts, after standardization, can be effectively sealed. The lamp used is seasoned and is run at such low efficiency and for such short times as to insure the greatest possible constancy.

The construction of the reference standard is shown in Fig. 24. In use this element is placed upon the test plate so that the plate is illuminated by the standardized lamp through the opening *C*. Before leaving the factory the reference standard lamp is so seasoned and calibrated that when a current of the value given

in the accompanying certificate is passed through the lamp, there will be a definite illumination upon the test plate. The illuminometer may then be calibrated by placing the sighting aperture into the hole marked *D* and adjusting the current through the working standard.

If the brightness observed is too large or too small to be read directly on the scale of the illuminometer, it is necessary to use absorbing screens. If the brightness observed is too large, the absorbing screen is placed between the optical cube and the test plate or other surface whose brightness is to be determined. If the brightness observed is too small, the screen is placed between the cube and the working standard.

In making measurements under conditions where a great hue difference exists between the two fields of the cube, such as for daylight measurements, special filters may be used to produce a color match. When using these filters, a factor must be used in interpreting the results. The factor depends not only upon the filter but also upon the spectral characteristics of the brightness being observed. (Filters and filter factors are discussed in detail in Chap. 8.)

24. Light-sensitive Cells.—The term *photoelectric* is used in a general sense to indicate any electrical effect due to the influence of radiant energy having a wave length or wave lengths *comparable* to but not necessarily identical with those wave lengths effective in producing luminous effects. The change of electrical resistance of selenium when exposed to such radiant energy is spoken of as a *photoelectric action*. Such a device requires an auxiliary source of electrical energy to function.

The ejection of electrons under the influence of such radiant energy is likewise a photoelectric effect. Various photoemissive tubes, commonly called *phototubes*, which are enclosed in glass and designed to operate in either a vacuum or gas atmosphere, have been developed. Phototubes also require an auxiliary source of power to function effectively.

The production of an electromotive force between metals when exposed to radiant energy of wave lengths comparable to the wave lengths producing luminous effects is also a photoelectric effect. Equipment dependent upon this principle of operation is being used today for direct-measuring illuminometers. The equipment involved consists of a rigid metallic-base disk support-

ing a layer of light-sensitive selenium material connected with a metallic current-collecting ring. The supporting base acts as a positive terminal, and the metallized top surface as a negative. Such a device is called a *blocking layer* or *barrier layer cell* or more generally a *light-sensitive cell*. No auxiliary source of electrical energy is required for the functioning of this cell. It converts its own electrical energy from the radiant energy received on its surface. There is no evacuated or gas-filled space as in the phototube.

25. Light-sensitive Cell Characteristics.—When the cell is connected to an external circuit, *e.g.*, a microammeter, an

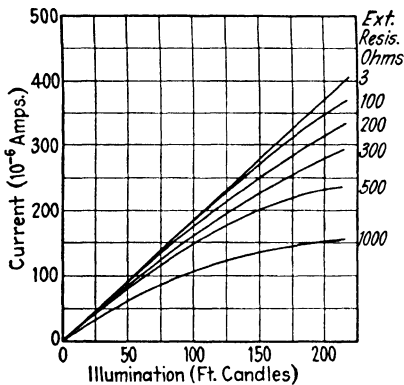

FIG. 25.—Weston, type 1, photonic cell (tungsten lamp source at 2700°K).

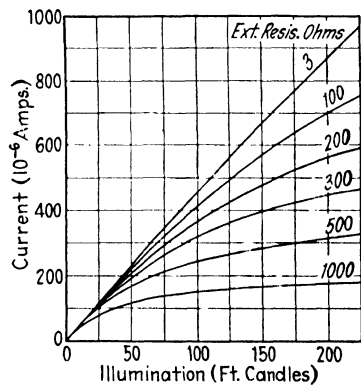

FIG. 26.—Weston, type 2, photonic cell (tungsten lamp source at 2700°K).

electrical current flows in the circuit. The current output of the cell varies with the radiation upon it and also with the resistance of the external circuit. The relationships between current and incident illumination for several cells are shown in Figs. 25 to 28. A cell has an internal leakage path which acts as a resistance in parallel with the resistance of the external circuit. Consequently for large external-resistance circuits the leakage current may be comparable to the external circuit. The internal-leakage resistance decreases as the illumination increases. Consequently the "saturation" effect at higher values of external resistances is accounted for.

A knowledge of the relative spectral sensitivities of light-sensitive cells is extremely important if the cells are to be used intelligently. The spectral sensitivity versus wave length char-

acteristic is essentially constant for a given cell except when a very high external-resistance circuit is applied. Such a circuit does not yield linear response or high sensitivity and generally

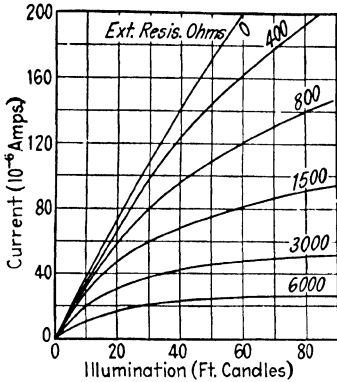

FIG. 27.—General Electric light-sensitive cell (tungsten lamp source at 2700°K.).

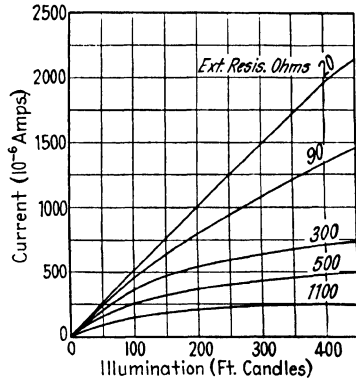

FIG. 28.—G.M. type F-3 visatron self-generating cell (source of radiation not given but probably tungsten lamp at 2700°K.).

is avoided. Hence changes in relative spectral response with change of external-circuit conditions will not be considered in this discussion. Relative sensitivities for cells of several manu-

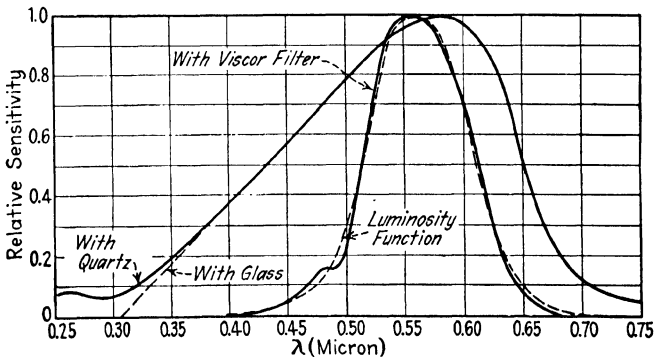

FIG. 29.—Spectral sensitivity of Weston, type 1, photonic cell with various window materials.

factures are given in Figs. 29 to 32. On each curve is plotted the luminosity function as given in Fig. 11. Where it is desirable that the spectral response of the cell be equivalent to that of the luminosity function, cells are available with filters. A scale of

an illuminometer using a cell having a characteristic such as that of Figure 30 must be calibrated for *one particular spectral distribution of radiant energy*. If the same cell is used in an attempt to measure the illumination produced by another source having

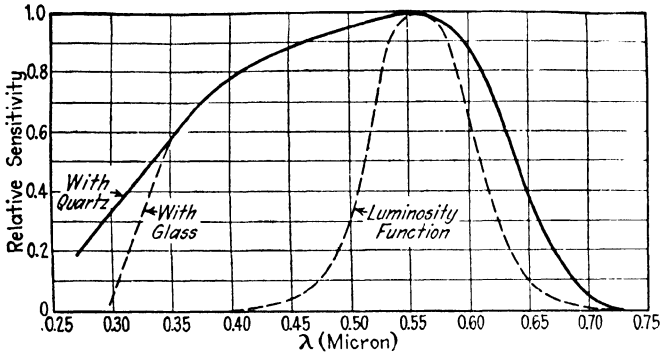

FIG. 30.—Spectral sensitivity of Weston, type 2, photonic cell.

a different spectral distribution of radiant energy, the reading obtained on the instrument probably will not represent the illumination. For example, assume that the illuminometer is

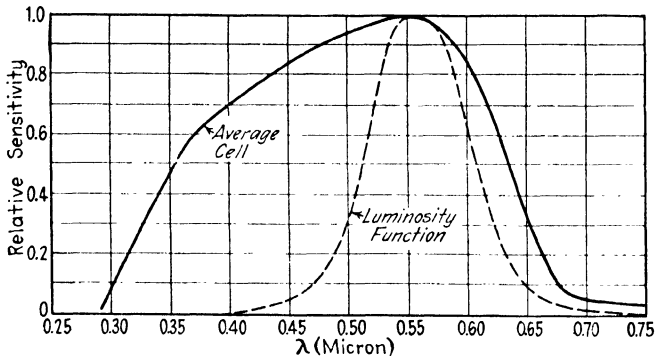

FIG. 31.—Spectral sensitivity of General Electric light-sensitive cell.

calibrated to read correctly for an incandescent tungsten filament source at 2700°K. If this same cell is subjected to radiant power of, say, 3500 Å. wave length, a substantial deflection on the instrument would result; whereas the illumination would be essentially zero. A cell having a spectral sensitivity similar to the luminosity function would yield essentially no response. It is possible that correction factors be calculated for radiant-power

densities differing in spectral distribution from that for which the scale is calibrated. The method is not completely satisfactory if the illumination being measured is derived from more than one source each having a different spectral characteristic.

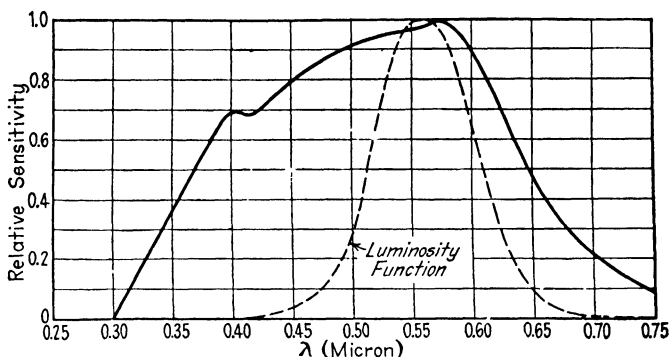

FIG. 32.—Spectral response of G. M. visitron self-generating cell.

Reflections from colored reflecting surfaces also complicate the procedure.

The effect of radiant energy impinging upon the cell from various angles is another important consideration. Were the absorbing and reflecting properties of the cell surface constant for all angles of incidence, then the effect of illumination upon the response of the cell would be constant. However, these properties vary somewhat, particularly as the angle of incidence approaches 90 deg. where the shadow cast by the rim of the case also tends to reduce the cell response. The actual response for a cell is shown in Fig. 33. Other cells have similar but not necessarily identical relationships.

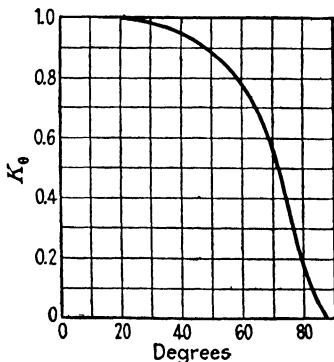

FIG. 33.—Effect of angle-of-light incidence on the current output of a Weston, type 1, cell. (K_{θ} = numeric by which the scale reading must be divided to yield the true value.)

26. Determination of Apparent Intensity.—The apparent intensity of a source in some given direction is determined through a measurement of the illumination resulting at a point on a particular plane. The position of the plane and the

distance from the point on that plane to the source are geometric conditions that must be known. The measurement is usually made to the center of the light source, which is usually the center of the filament of the lamp. If more than one lamp is used in a source, the distance is that to the weighted geometric center of the group. This position is called the *light center*. The customary distance at which measurements of illumination are made for determining apparent intensity is 10 ft. This establishes a rather uniform meaning to apparent intensity, but the distance should be specified. Certain sources, such as spotlights, may require measurements at a greater distance if the apparent intensity is to be useful for application.

The intensity of a light source varies with the direction considered. A complete determination of the intensities of a source thus involves not one determination but many. Various means of making these determinations have been developed. If a source possess axial symmetry, the complete determination involves measurements through 180 deg., starting and ending at the axis of symmetry. Equipment for making such a set of determinations is herein described.

A distance of, say, 10 ft. from the light center to the point of measurement of illumination can be maintained by placing a light-sensitive cell upon a radial arm. The diameter thus involved is 20 ft., and except in rooms with very high ceilings such a diameter is impractical. It is generally not possible to swing the arm in a horizontal plane, since most large units cannot be operated satisfactorily except with their axis of symmetry vertical.

A system of mirrors may be used to reduce the maximum dimensions necessary to manipulate the equipment. One possibility is to use two mirrors, both movable, as in Fig. 34. The mirrors may be placed in any position so that the intensity is determined through 180 deg. in a vertical plane. The distance along the path from the source to the measuring device is usually 10 ft.

A simplification is to use but one mirror as in Fig. 35. The light incident upon the measuring device is now at an angle β not equal to zero as was the case for the two-mirror distribution photometer. However, the angle is constant with various mirror positions, provided the device is positioned properly. The

absorption by the mirror and the effect of the angle of incidence must be included in the calibration of the equipment. Plotting the data obtained from such a device is considered in Chap. 6. The source may be rotated about its axis of symmetry to give an average effect at the measuring device to account for the slight variation of intensity caused by filament construction and

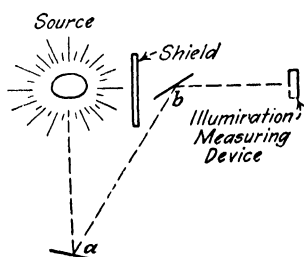

FIG. 34. Distribution photometer with two movable mirrors.

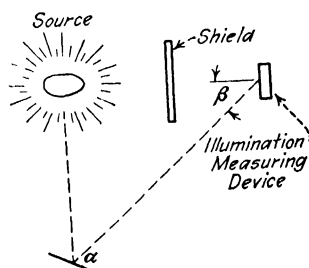

FIG. 35.—Distribution photometer with one movable mirror.

irregularities in glassware or reflector construction. With a light-sensitive cell and microammeter as the measuring device the averaging can be accomplished by using an instrument having sufficient damping to reduce needle fluctuations. The maximum speed at which the source can be rotated is approximately 3 revolutions per second. Beyond that speed, filament distortion due to centrifugal force may cause errors in results or the filament may be distorted to such an extent as to cause failure.

27. Determination of Total Luminous Flux Emitted by a Luminous Source.—The total luminous flux emitted by a source may be determined by one illumination measurement using an integrating device known as an *Ulbrich sphere*. The source for which the luminous flux is desired is placed inside this sphere, and the illumination at an opening in the surface of the sphere is proportional to the luminous flux emitted by the source. (The direct illumination from the source at the opening in the surface must be intercepted by a screen.)

The theory of the Ulbrich sphere is based upon several approximations. The first consideration is that the inner surface of the sphere shall be perfectly diffusing, *i.e.*, have constant brightness from any angle of observation. (Diffusion is considered in more detail in Arts. 30 and 31 of Chap. 6.) Let a hollow sphere of

radius a contain a luminous source L . Every point on the interior of the sphere will have an illumination made up of a component of illumination direct from the luminous source and

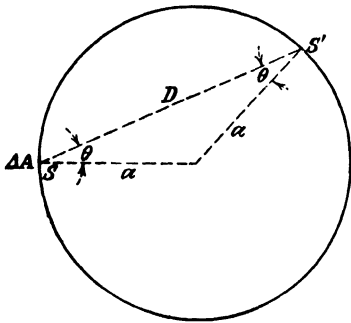

FIG. 36.—The Ulbricht sphere.

the remainder from the inner surface of the sphere itself acting as a secondary source. Obviously the direct component will depend upon the position of the source in the sphere and the manner of distribution of the luminous flux from the source. This component is to be shielded from the measuring device in the surface of the sphere.

Let the brightness of the surface at the point S in Fig. 36 be B_s .

The element of illumination at some other point S' due to an element of area dA at S then would be

$$dE_{s'} = \frac{B_s \cos \theta (\cos \theta dA)}{D^2} = \frac{B_s}{D^2} \cos^2 \theta dA \quad (45)$$

But

$$D = 2a \cos \theta$$

and

$$D^2 = 4a^2 \cos^2 \theta$$

Therefore

$$dE_{s'} = \frac{B_s \cos^2 \theta}{4a^2 \cos^2 \theta} = \frac{B_s}{4a^2} dA \quad (46)$$

Note that $dE_{s'}$ is independent of the position of S' and depends only upon the brightness of the surface at S and the radius of the sphere. Since the brightness of the surface at the point S is constant for any position of S' (perfect diffusion), the indirect component of illumination at *any* point on the sphere due to the element dA is the same. Now consider S at any point on the interior. The contribution to every other point is still the same if the brightness at the new position of S is the same as before.

Strictly, the brightness (which is due not only to the indirect component but to the direct component as well) is not constant over the sphere. If the emission of flux is reasonably uniform, the

direct component of the illumination over the sphere also can be made reasonable uniform by placing the source near the center of the sphere. Then the resulting brightness of each point on the surface is more nearly that at every other point. The variation of brightness from point to point, even with the same primary source position, can be made extremely small by using a surface that reflects a very high percentage of the luminous flux received; *i.e.*, the indirect component can be made large with respect to the direct component. Inasmuch as the relationship involving only the indirect components indicates uniform effects throughout the sphere, the illumination upon a measuring device placed in a small opening in the wall of the sphere (which is shielded from the direct rays of the source) is a measure of the flux emitted by the source. Calibration is accomplished through a substitution method involving a source emitting a known luminous flux. Various refinements can be made to compensate for such causes of error as absorption by the luminaire itself of the luminous flux that has been reflected one or more times from the sphere. Obviously this effect would be great were the luminaire large with respect to the dimensions of the sphere. Consequently rather large spheres are required to measure with a reasonable degree of accuracy flux emitted by large sources.

Modifications of the spherical form are being used with corresponding degrees of accuracy. The first step is to reduce the sphere to a surface composed of many plane sides. The construction is much simpler; the investment cost less; and the accuracy only slightly impaired. The limiting form is the cube, which is being used to some extent in England. With refinements in technique in compensating for the errors involved, the final results can be made quite accurate with respect to the simplicity of the equipment involved.

Problems

1.5. A type 1, Weston photronic cell with glass window is calibrated to read correctly the illumination from an incandescent-lamp source operating at 2950°K. If this same instrument is to be used to measure illumination from a high-pressure mercury-vapor lamp, what factor must be applied to the reading to give the illumination? Is the instrument more sensitive or less sensitive to this source of radiant energy than to the incandescent source? Is this logical?

2.5. The distribution photometer of Fig. 35 utilizes a G.M. type F-3 self-generating cell and a 1000 microammeter. The resistance of the external

circuit of the cell circuit is 90 ohms. The distance from the light source to the cell via the mirror is 10 ft. The mirror reflects 82 per cent of the light incident upon it at an angle of reflection equal to the angle of incidence. The distance from the light center to the mirror is 48 in. and that from the mirror to the center of the cell is 72 in. The center of the cell is located on the horizontal center line through the light center, and the plane of the cell is normal to this line. If the cell receives light at the angle β of the problem in exactly the same manner as the cell of Fig. 33, what is the maximum apparent candle power at 10 ft. that can be measured by this combination?

REFERENCES

- W. N. Goodwin, Jr., The Photronic Illumination Meter, *Trans. Illum. Eng. Soc. (N.Y.)*, **27**, 1932, pp. 828-835.
- C. L. Dows and C. J. Allen, The Light-meter and Its Uses, *Trans. Illum. Eng. Soc. (N.Y.)*, **31**, 1936, pp. 675-684.
- The G. E. Light-sensitive Cell, Technical and Descriptive Data, *Gen. Elec. Bull.* GEA-2467, 1936.
- Viscor Filter, *Weston Elec. Inst. Corp. Circ.* B-9A, 1937.
- R. H. Mighell, The Light-Sensitive Cell, *Gen. Elec. Rev.*, 1937, pp. 372-375.
- Weston Photoelectric Cells, Technical Data, *Weston Elec. Inst. Corp. Circ.* B-18A, 1938.
- Visitron Self-generating Cells, *G. M. Comments*, 10, 1939.
- Photometers and Accessories, Leeds and Northrup Co. Catalog E-72. 1940.

CHAPTER 6

GEOMETRIC GRAPHS AND THEIR APPLICATION

<i>Symbol</i>	<i>Term</i>	<i>Definition</i>
	Geometric graph	A graph illustrating some variable in the illumination system as a function or functions of geometric quantities (distances, or angles) as distinguished from spectroradiometric graphs.
M.S.C.P.	Mean spherical candle power	The mean value of the intensities of a source taken in an infinite number of positions uniformly distributed in direction from the center of the luminous source.
M.H.C.P.	Mean hemispherical candle power	The mean value of the intensities of a source taken in an infinite number of positions uniformly distributed in one hemisphere whose center is the center of the luminous source.
	Perfect diffusion	Having an intensity distribution from an element of the source which obeys the relation $\Delta I(\alpha) = \Delta I(0) \cos \alpha$, where $\Delta I(0)$ is the intensity of the element at $\alpha = 0$. Likewise, having a constant brightness distribution with respect to angle of observation.
	Luminaire efficiency	Ratio of flux emitted by the luminaire and lamp to that emitted by the lamp alone expressed as a percentage.

28. Intensity-distribution Curves.—Intensity (or apparent intensity) is a very useful concept in certain illumination calculations. As has been noted, the relationships involving intensity of a source as a whole must be applied with caution. However where methods involving the idea can be used, the calculations necessary in determining resulting illuminations are greatly simplified.

The apparent intensity at some specified distance varies with the direction from the source for most luminous sources. Consequently a three-dimensional graph would be required to express

the apparent intensity as a function of the horizontal and vertical angles. A family of curves is usually used to represent such data on a plain sheet of paper—each curve representing the variation of intensity as one of the angles completes a cycle of 360 deg. while the other angle remains at some predetermined value.

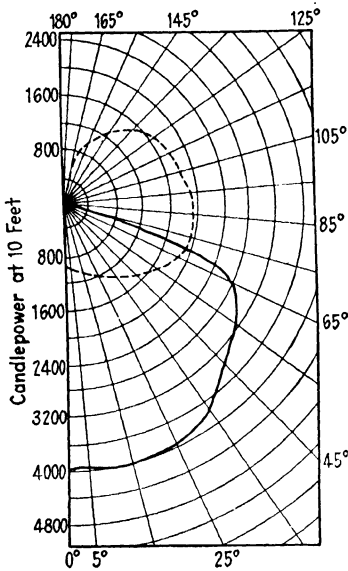

FIG. 37.—Intensity (candle-power) distribution for a standard industrial reflector.

Many sources have at least some degree of symmetry. Some have planes of symmetry; others have axial symmetry (*i.e.*, symmetry except for variation of intensity with one angle). It is theoretically possible that a source have complete symmetry.

For sources with axial symmetry the variation is usually with the vertical angle. For such sources a plot of intensity versus the vertical angle through 180 deg. starting and ending at the axis of symmetry completely pictures the geometric variation of intensity of the source. Usually the data are plotted on polar coordinates as Fig. 37, which represents the apparent intensity distribution at 10 ft. for a standard industrial reflector and lamp.

The dotted curve represents the distribution for the lamp alone. (The term *candle power* is used interchangeably with intensity.)

29. Applications of Intensity-distribution Curves.—The direct illumination at a location or series of locations as caused by a source can be determined from the geometry of the position of the source to that of the point on the receiver plane and from the intensity- or candle-power distribution curve. The restrictions of the treatment of the source as a whole must always be considered.

As an application of the intensity-distribution curve, consider the luminaire source of Fig. 37 placed with its axis of symmetry vertical and with the center of source 8 ft. above the floor (Fig. 38). The illumination at a point *P* on the floor 6 ft. from a

point on the floor directly below the fixture is desired. The illumination at P from equation (16a) is

$$E_p = \frac{I}{D^2} \cos \beta \tag{16a}$$

where E_p = illumination at the point P , in lumens per square foot.

I = intensity of the source in the direction of P (i.e., at angle θ from the vertical), in candles.

D = distance from the light center of the source to the point P , in feet.

β = the angle between the normal to the receiving surface at P and the distance D (i.e., the angle θ in Fig. 38).

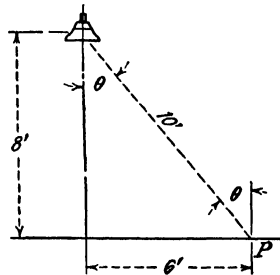

FIG. 38.—Application of the intensity distribution to a simple case.

The intensity cannot be read from the distribution curve until the angle θ is determined. $\theta = \arctan \frac{6}{8} = 37$ deg. From the curve the intensity of the source in the direction of the point P is approximately 3700 candles. The distance D is 10 ft., and the cosine of the angle is 0.80. Hence

$$E_p = \frac{3700}{(10)^2} \times 0.8 = 29.6 \text{ lumens/sq. ft.}$$

Since the distance D is exactly 10 ft., the illumination thus obtained is as accurate as the intensity-distribution curve was read. If the distance were other than 10 ft., the result would be approximate to the extent of any change in apparent intensity with distance. With the point P always on the floor the results for this source whose maximum dimension probably does not exceed 18 to 24 in. would probably be in the range of engineering accuracy. If the point P be brought within several feet of the source, the result as calculated from the apparent intensity at 10 ft. would have little if any meaning.

Generally the height of all luminaires above some horizontal plane is constant. Under such conditions the calculation of illuminations from many units can be systematized to advantage.

If the height of the units above the plane is called h and the horizontal distance from the point at which the illumination is

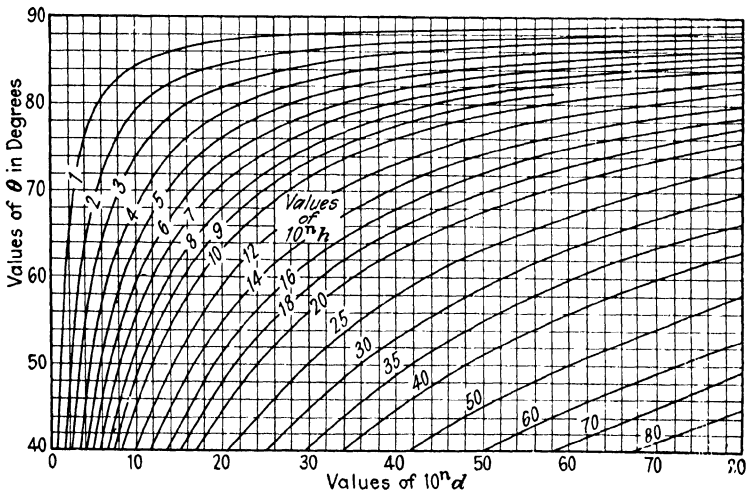
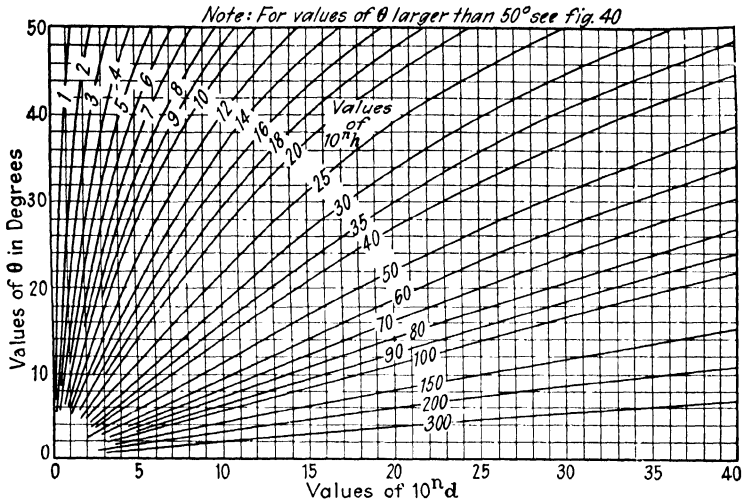

desired to a point on the plane directly below the unit is called d , then equation (16a) can be written as

$$\begin{aligned}
 E_p \text{ (on horizontal)} &= \frac{I(\theta)}{h^2 + d^2} \cos \theta \\
 &= I(\theta) \frac{\cos^3 \theta}{h^2}
 \end{aligned}
 \tag{47}$$

Since h^2 is a constant of the system, the illumination is determined when $I(\theta)$ and $\cos^3 \theta$ are known.

Likewise, if the illumination upon a vertical plane is desired, the equation can be written as

$$\begin{aligned}
 E_p \text{ (on vertical)} &= \frac{I}{h^2 + d^2} \sin \theta \\
 &= I(\theta) \frac{\sin^3 \theta}{d^2}
 \end{aligned}
 \tag{48}$$

Generally d^2 will not be a constant of the system, and hence the simplification of the illumination upon the vertical is not so direct.

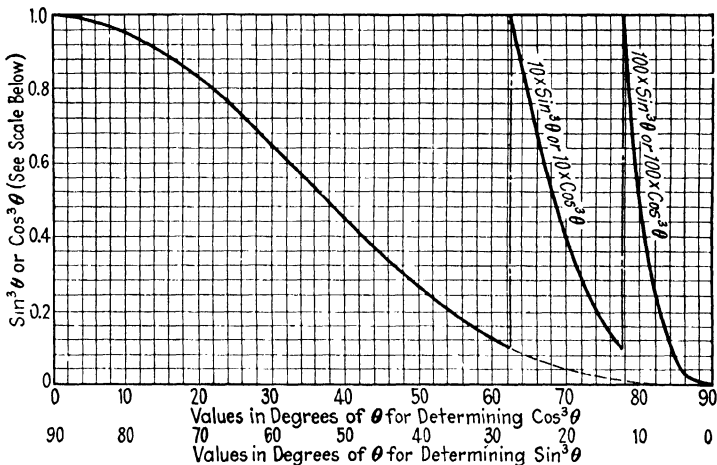

FIG. 41.—Chart for the determination of $\cos^3 \theta$ or $\sin^3 \theta$.

In either case the angle θ must be determined. The charts of Figs. 39 and 40 facilitate this determination. The charts are simply a plot of the tangent functions of θ and are so arranged that the angle can be determined for a considerable range of d and h . Multiples and submultiples of 10 can be employed against both d and h for enlarging the normal range of the scales. The charts are independent of units employed for d and h except that both must be the same.

The chart of Fig. 41 may be used to advantage in determining $\cos^3 \theta$ or $\sin^3 \theta$ for use in the equations for the illumination upon the horizontal or the vertical plane respectively. The values less than 0.1 and 0.01 have been plotted enlarged by 10 or 100, respectively, for improved accuracy at such angles.

The luminous flux emitted by a source as a whole also can be determined from the intensity-distribution curve. Consider the

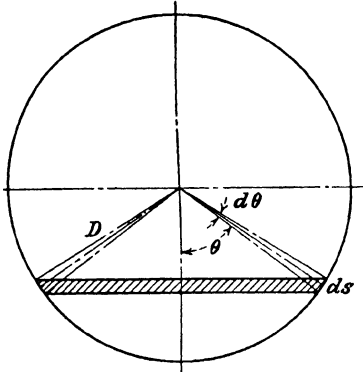

FIG. 42.—Zonal areas as determined through angular position.

luminous source at the center in Fig. 42. About this source as a center consider a sphere of radius D . If D is large with respect to the dimensions of the source, the intensity as specified through the limit as $D \rightarrow \infty$ of ED^2 is the true intensity of the source. At some angle θ with the reference axis (usually taken as the downward vertical), the intensity is $I(\theta)$ as determined from the intensity-distribution curve. If the intensity varies in the horizontal angle as θ is fixed, the following method is still applicable. If such is the case, consider the average value of the intensity for the particular vertical angle as the horizontal angle takes on all values through 360 deg. Let $d\theta$ represent a differential angle, and ds be the differential arc subtended by $d\theta$ at the distance D , or

$$ds = Dd\theta \quad (49)$$

The area of the elementary strip as the horizontal angle varies through 360 deg. is

$$dA = 2\pi D \sin \theta ds \quad (50)$$

The average illumination over the elementary strip is I/D^2 , where I is the average value at θ deg. as the horizontal angle varies through 360 deg. If the source is symmetrical except for variation of θ , then the average illumination or the average intensity is the same at any horizontal angle at that particular vertical angle θ .

Inasmuch as $d\phi = E dA$, the flux passing through the elementary area is

$$\begin{aligned}
 d\phi &= E dA = \frac{I}{D^2} 2\pi D^2 \sin \theta d\theta \\
 &= 2\pi I \sin \theta d\theta
 \end{aligned} \tag{51}$$

Integrating between the limits of θ_1 and θ_2 gives

$$\phi_{(\theta_2-\theta_1)} = 2\pi \int_{\theta_1}^{\theta_2} I \sin \theta d\theta \tag{52}$$

In general the intensity varies with the angle θ . If the mean value of the intensity between the limits θ_1 and θ_2 is taken as a constant of the integration, then

$$\begin{aligned}
 \phi_{(\theta_2-\theta_1)} &= 2\pi I_{\text{mean}} \int_{\theta_1}^{\theta_2} \sin \theta d\theta \\
 &= 2\pi I_{\text{mean}} \left[-\cos \theta \right]_{\theta_1}^{\theta_2} \\
 &= 2\pi I_{\text{mean}} (\cos \theta_1 - \cos \theta_2)
 \end{aligned} \tag{53}$$

where $\phi_{(\theta_2-\theta_1)}$ = flux in the zone between θ_1 and θ_2 .

$I_{\text{mean}} \Big|_{\theta_1}^{\theta_2}$ = mean value of the intensity between θ_1 and θ_2 .
 $\cos \theta_1 - \cos \theta_2$ = difference of the cosines of the respective angles of the limit.

Equation (53) is the basis for a determination of the luminous flux emitted by a source from the intensity-distribution curve. For increments of $\Delta\theta = (\theta_2 - \theta_1)$, the various values of $2\pi (\cos \theta_1 - \cos \theta_2)$ can be calculated. Each of these values should be multiplied by the mean value of intensity over the $\Delta\theta$. A summation process through 0 to 180 deg. then adds all the elements of flux emitted by the source.

The accuracy of the method is determined through two items. First, the intensity-distribution curve must be a limiting value of apparent intensity. If the distribution curve used is taken at too small a distance D , the luminous flux obtained from the method in general will be too small. And second, the mean value of intensity in the increment of $\Delta\theta$ must be used. Often this intensity is difficult to obtain with great accuracy on polar coordinates in the region of $\theta = 90$ deg. where the intensity may be changing radically with angle. For this reason a plot on rectangular coordinates has merits. The smaller the increments the more accurately the mean intensity may be read from the curve. The second limitation on accuracy could be stated in

another manner. If the value of intensity at the *middle* of the zone is always used, then the smaller the increments the better the accuracy.

TABLE 3.—ZONAL CONSTANTS FOR COMPUTING LUMINOUS FLUX FROM INTENSITY-DISTRIBUTION CURVES

θ_2	θ_1	θ_2	θ_1	$2\pi(\cos \theta_1 - \cos \theta_2)$
10	0	180	170	0.0954
20	10	170	160	0.2835
30	20	160	150	0.4629
40	30	150	140	0.6282
50	40	140	130	0.7744
60	50	130	120	0.8972
70	60	120	110	0.9926
80	70	110	100	1.0579
90	80	100	90	1.0911

The values of $(\cos \theta_1 - \cos \theta_2)$ from 0 to 90 deg. will be identical with those from 180 to 90 deg., since the cosine function is symmetrical about 90 deg. except for a change of sign. Zonal constants for $\Delta\theta = 10$ deg. are tabulated in Table 3.

If $\theta_2 = 180$ deg. and $\theta_1 = 0$ deg. of equation (51), the $\phi_{(180^\circ-0^\circ)}$ is the total luminous flux emitted by the source. Still interpreting the intensity as the mean value in the $\Delta\theta$ the relationship for *mean spherical candle power* of the source becomes

$$\begin{aligned} \text{M.S.C.P.} &= \frac{\text{total flux from source}}{2\pi[1 - (-1)]} \\ \text{M.S.C.P.} &= \frac{\text{total flux}}{4\pi} \end{aligned} \quad (54)$$

If $\theta_2 = 90$ deg., and $\theta_1 = 0$ deg., the $\phi_{(90^\circ-0^\circ)}$ is the luminous flux emitted below the horizontal and the lower mean hemispherical candlepower is

$$\begin{aligned} \text{Lower M.H.C.P.} &= \frac{\text{flux of lower hemisphere}}{2\pi(1 - 0)} \\ \text{Lower M.H.C.P.} &= \frac{\text{flux of lower hemisphere}}{2\pi} \end{aligned} \quad (55)$$

Likewise the upper mean hemispherical candle power is

$$\text{Upper M.H.C.P.} = \frac{\text{flux of upper hemisphere}}{2\pi} \quad (56)$$

Equations (54), (55), and (56) bear out the statement made in the preceding chapter that *dimensionally* the candle and the lumen were the same, since 4π and 2π are dimensionless solid angles.

30. Intensity-distribution Curve of an Element of a Source.—Let ΔA be the elementary area of a luminous source of such small dimensions that it may be considered plane. Illuminations resulting from this source will be considered only at such distances that the source acts as a point. Consequently for conditions at the source it is possible to consider the normal to the plane of the source and at the same time to consider the source as a point in evaluating conditions at a distance. This is the same procedure as that illustrated in Fig. 17, page 31.

The intensity of the elementary source can be represented by an intensity-distribution curve or curves. If the intensity is plotted for variation of angle in some one plane perpendicular to the plane of the element, as in Figure 43, the usual intensity-distribution curve will result, except that the intensity must always approach zero as the angle approaches the plane of the source. If the distribution curve is to represent conditions external to the material boundary of the source, then the complete curve will exist in an angular variation of only 180 deg.; whereas a source as a whole may require 360 deg. of observation for a complete distribution curve.

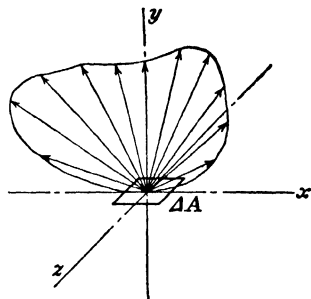

FIG. 43.—Intensity distribution from an element of a plane source.

A solid figure again would be needed to demonstrate completely the variation of intensity with both vertical and horizontal angles. However, a series of curves can be used to represent conditions at chosen values of one of the angles as has been discussed previously.

31. Brightness-distribution Curve for an Element of a Luminous Source.—The intensity of the elementary source will now be treated as in Art. 17 and in particular as in equation (15), which related brightness and intensity as

$$\mathcal{B} = \frac{1}{\cos \alpha} \frac{dI}{dA} \quad (15)$$

Instead of considering conditions as an infinitely small source dA , the source considered is of finite dimensions ΔA . Hence the degenerated form of equation (15) would be

$$B_{\text{ave.}} = \frac{1}{\cos \alpha \Delta A} \Delta I \quad (57)$$

where $B_{\text{ave.}}$ is the average brightness of the source ΔA in the direction of α deg. from the normal. A plot of $\cos \alpha \Delta A$ as the angle varies through 180 deg. would be simply a polar plot of the cosine function as in Fig. 44 with a maximum value of ΔA .

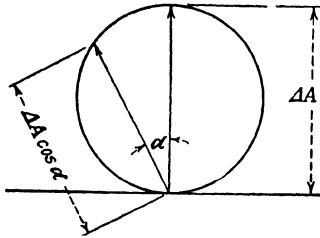

FIG. 44.—Cosine function plotted in polar coordinates.

function as in Fig. 44 with a maximum value of ΔA .

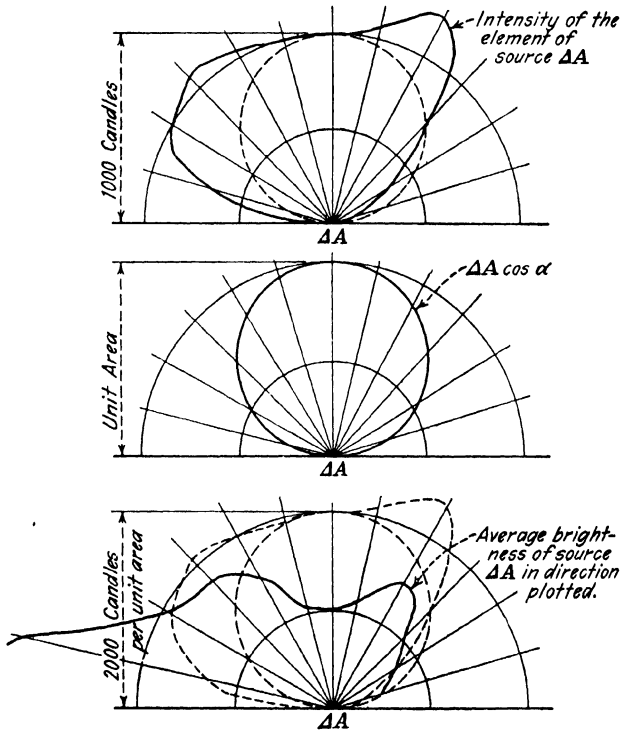

FIG. 45.—Method of determining brightness-distribution curve from an intensity-distribution curve for an elementary source.

Since the average brightness of the element is the ratio of the intensity of the element to the $(\cos \alpha \Delta A)$, the average bright-

ness distribution for an element ΔA would be represented by a point-by-point plot as in Fig. 45.

If the intensity distribution from the element of surface were identical with the polar plot of the cosine function of the angle measured from the normal, the division of identities (except for magnitudes) would yield a constant value of brightness. At angles of α other than ± 90 deg. the constancy of the brightness is obvious. However as α approaches ± 90 deg., conditions must be considered as a limiting process. Both the intensity and the projected area approach zero, and the value at zero is in the indeterminate form when $\Delta I = 0$ and $\cos \alpha = 0$ are substituted. However, both functions approach zero in an identical manner and hence the limit at $\alpha = \pm 90$ is the value $\Delta I(0)/\Delta A$. The plot of brightness as α takes on various angles for this special case is as shown in Fig. 46.

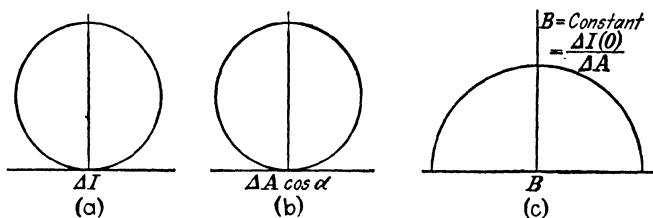

Fig. 46.—Intensity distribution and brightness distribution for a perfectly diffusing source.

Such a surface source obviously is an idealized source. The emission is said to be perfectly diffuse.

32. Application of Brightness-distribution Curves.—In order that the brightness term of equation (17) be considered constant for the integration process, each element of the surface must exhibit the property of perfect diffusion and also each element must possess the same magnitude of brightness as every other element. If such be the case, then

$$E_p = B \int_s \frac{\cos \alpha \cos \beta}{D^2} dA \quad (58)$$

The integration process is thus greatly simplified.

If the brightness of the source is not constant over the surface, then a knowledge of how the brightness varies with position and angle is necessary. For most sources an analytic expression for \mathcal{B} is not simple or perhaps even possible. A series of curves such as in Fig. 46c would specify conditions at chosen points of the

surface. An approximate result (illumination at a particular point) can be found by breaking the surface up into sections of such size that the brightness can be considered as a constant over each section. The larger the number of sections the more accurately the true result can be approached. Any general method dealing with surface sources of nonuniform brightness is either only approximate or very unwieldy in application.

33. Illumination-distribution Curves.—A representation of illumination conditions over a surface involves three variables: the illumination and the two coordinates describing the location of points on the surface. To picture completely how the illumination varies over a surface, a three-dimensional plot is required. The base of the solid could represent the surface involved with the height of the figure a measure of the illumination.

If one of the coordinates of the surface is held fixed, the variation of illumination with the other coordinate can be shown on a

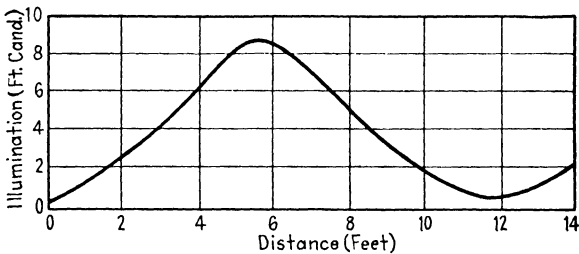

FIG. 47.—Illumination on the working plane along a line passing under a fixture.

plain sheet of paper. Figure 47 illustrates the manner of variation of illumination on a plane 30 in. above the floor taken on a line at the intersection of the horizontal working plane and a vertical plane passing through the center of a fixture. The data were taken in the Pine Room of the Iowa State College Memorial Union.

The illumination along another line parallel to the first and displaced from it 1 ft. could be shown by another curve so designated in Fig. 48. Several such curves at various displaced lines are given. Thus a family of curves can illustrate the variation of illumination over the surface.

Another method of illustrating the variation of illumination is through an illumination contour map. The preceding method

represented vertical sections through the three-dimensional solid which illustrated completely the illumination over the surface. The second method utilizes horizontal sections of the solid; *i.e.*, one curve represents positions on the surface having a chosen

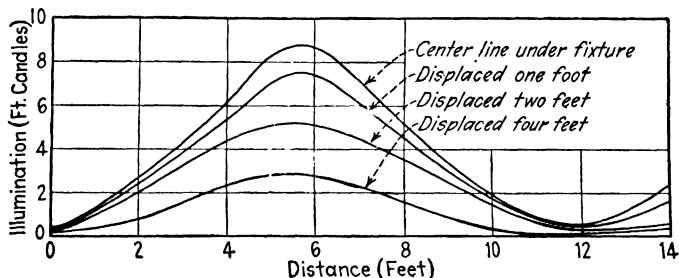

FIG. 48.—Illumination on the working plane along several parallel-line positions.

value of illumination. Another curve represents positions having another value of illumination, etc. The particular unit illustrated in Fig. 48 is symmetrical within itself and hence should

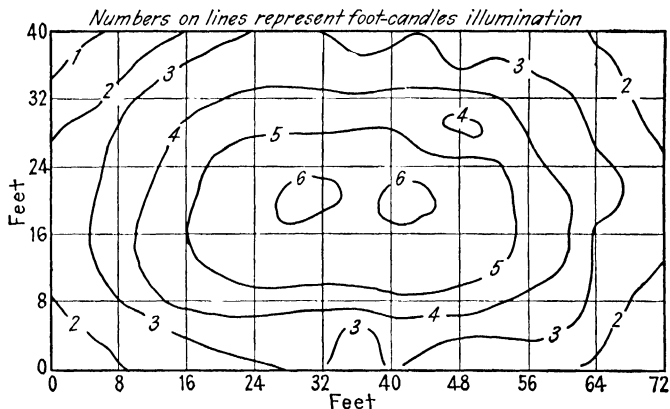

FIG. 49.—Illumination contour for judging pavilion, Iowa State College Animal Husbandry building.

produce lines of constant illumination which are circles centered about the point directly below the unit. However, other units in the room were lighted at the time the data were taken, and hence the pattern is not so regular. Reflection of light from the side walls and ceiling of the room also produced some effect which is also represented in Fig. 48. A pattern for a complete room is shown in Fig. 49. The illumination illustrated is that in the

judging pavilion of the Meat Laboratory in the Iowa State College Animal Husbandry building. The term *iso-foot-candle diagram* is often applied to such diagrams.

34. Relationship between Brightness and Luminosity for a Perfectly Diffusing Source.—An interrelationship of the units associated with brightness and those associated with luminosity (as defined in this text) has been attempted by the American Standards Association. Both of the units are then stated as applying to brightness. The relationship between the units is established through the medium of a perfectly diffusing source. Such an attempt at a combination of ideas based upon a special condition for a source seems to the writer to cause nothing but confusion. As a result this text will omit completely the ideas behind the attempt at the combination.

However, for a perfectly diffusing surface, having as it does a constant brightness from any angle of observation, the relationship between the brightness at a point on the surface and the luminosity at the same point is very convenient. It has been noted previously that, unless the brightness of the source is a constant with angle of observation, an integration process for a resulting illumination was prohibitively difficult in most cases. A discussion of reflection factors and similar items is presented in Chap. 8. Such conditions have to do with illumination and luminosity, not with brightness.

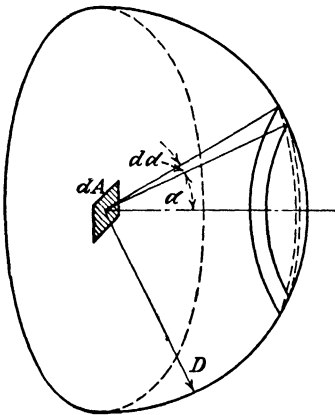

FIG. 50.—An element of a source possessing the property of perfect diffusion.

Hence to obtain the condition of a surface promoting an effect in a particular direction for the special case of a perfectly diffusing surface, the relationship between luminosity and brightness is extremely important.

In Fig. 50 let dA be a differential element of the perfectly diffusing surface. The brightness of the element in any direction will be a constant value B . The element of illumination on a hemisphere of radius D resulting from the differential element which lies in the plane of the great circle of the hemisphere is

$$dE = \frac{B}{D^2} \cos \alpha \, dA \quad (59)$$

Consider an elementary area on the hemisphere. This can be taken most conveniently as a strip of area ($D \, d\alpha$) ($2\pi D \sin \alpha$) as in the figure. The element of luminous flux *passing through this elementary receiver* due to the elementary source dA is

$$\begin{aligned} d\phi' &= dE \text{ (area of elementary receiver strip)} \\ &= \left(\frac{B}{D^2} \cos \alpha \, dA \right) (2\pi D^2 \sin \alpha \, d\alpha) \end{aligned} \quad (60)$$

The *total* of the element of luminous flux *passing through the whole hemisphere* due to the elementary source dA is

$$\begin{aligned} d\phi_E &= \int_{\alpha=0}^{\alpha=\frac{\pi}{2}} d\phi' = 2\pi B \, dA \int_{\alpha=0}^{\alpha=\frac{\pi}{2}} \sin \alpha \cos \alpha \, d\alpha \\ &= 2\pi B \, dA \left[\frac{\sin^2 \alpha}{2} \right]_0^{\pi/2} \\ &= 2\pi B \, dA \left(\frac{1}{2} \right) = \pi B \, dA \end{aligned} \quad (61)$$

Dividing both sides of equation (61) by dA ,

$$\frac{d\phi_E}{dA} = L = \pi B \quad (62)$$

or

$$B \left(\frac{\text{candles}}{\text{sq. ft.}} \right) = \frac{L \left(\frac{\text{lumens}}{\text{sq. ft.}} \right)}{\pi} \quad (62a)$$

for a perfectly diffusing source.

Thus the brightness *in any direction* at a point on a luminous surface possessing the property of perfect diffusion is numerically equal to the luminosity at that point divided by π .

Problems

1.6. Plot the illumination upon the floor of Fig. 38 against the distance from the point directly below the source for a range of distance from 0 to 20 ft. for the source of Fig. 37 with the reflector.

2.6. Determine the number of lumens of luminous flux emitted by the luminaire of the source shown in Fig. 37. Repeat for the lamp alone. What is the efficiency of the reflector equipment?

3.6. What is the mean spherical candle power of the luminaire of Fig. 37? Of the lamp alone?

4.6. What is the lower mean hemispherical candle power of the luminaire of Fig. 37? Of the lamp alone?

5.6. Plot the illumination contour map for the data represented in Fig. 48. Assume that conditions are identical on the two sides of the position *a*.

6.6. Plot the illumination along the center line of the room, taking the long length of the room for the data represented in Fig. 49.

7.6. If a black-body radiator at 2046°K . as of Fig. 9 emitted energy according to the cosine law of perfect diffusion, what would be its brightness from any angle of observation? How does this value compare with the 58.8 candles per square centimeter of Art. 17?

REFERENCES

- Illuminating Engineering Nomenclature and Photometric Standards, *Am. Standard Assoc.*, 1932.
- W. E. Barrows, "Light, Photometry, and Illuminating Engineering," McGraw-Hill Book Company, Inc., New York, 1938.

CHAPTER 7

DETERMINATION OF ILLUMINATION FROM SURFACE AND LINE SOURCES¹

35. General.—In the preceding chapter the intensity-distribution curve of a complete luminaire has been applied to the calculation of the direct illumination at a point on a receiver plane. In many instances, however, a source may be so extensive as viewed from the receiving point that it cannot be treated as a single unit possessing an intensity. The restrictions upon the concept of intensity have been considered previously in Chap. 4.

In such cases the fundamental integration process of equation (17) must be applied. The purpose of this chapter is to apply this method to several simple elementary geometric forms of sources and to present the end results in such form as will be convenient for engineering use.

Many of the sources to be considered will be treated as plane surfaces. However, the results may be applied to any source possessing the same brightness conditions as viewed from the receiving point, provided the boundary of the source from the point of view of this point is the same as that for the plane source. The fundamental reason of this extension of the case has been considered in Art. 17. Examples of other than plane sources will be discussed in many of the cases considered.

The restriction will be made in all cases that the brightness of the source shall be constant both as to position on the source and to angle of view of each respective point.

36. Plane-surface Source of Infinite Extent.—The illumination upon a plane parallel to a plane luminous source of infinite extent possessing constant brightness may be obtained by performing the surface integration of equation (17) over infinite limits.

A judicious choice of variables for specifying dA in the integral form is usually rather desirable. The polar form of the integral

¹ No new symbols, terms, or definitions in this chapter on calculation methods.

will be used here, since the differential area dA may then be determined through only one variable.

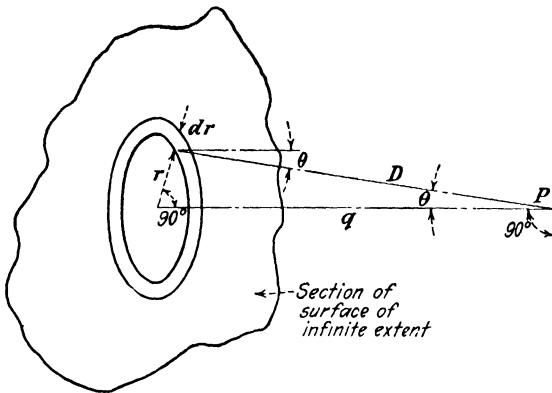

FIG. 51.—Source of infinite extent.

The illumination at P due to the differential element of area $dA = 2\pi r dr$ is

$$dE_p = \frac{Bq^2}{(r^2 + q^2)^2} (2\pi r dr) \quad (63)$$

since $dA = 2\pi r dr$, $\cos \alpha = \cos \beta = \cos \theta = q/\sqrt{r^2 + q^2}$, and $D^2 = (r^2 + q^2)$. The total illumination at P is

$$E_p = \pi q^2 B \int_0^\infty (r^2 + q^2)^{-2} 2r dr \quad (64)$$

$$= -\pi q^2 B (r^2 + q^2)^{-1} \Big|_0^\infty \quad (65)$$

$$E_p = \pi B \quad (66)$$

It should be noted that the illumination is independent of the distance q and is dependent only upon the brightness of the source. It was demonstrated in the preceding chapter that the luminosity of a perfectly diffusing source was also equal to πB . Hence the illumination at P (or the luminous flux density there) is equal to the luminosity of the perfectly diffusing source (or the luminous flux density of the source).

Often equation (66) may be employed as an approximation. In considering the illumination close to sources of rather large but not of infinite extent, the relationship may be as accurate as other accuracy limitations of the process. In such cases the simplicity of the result may be extremely useful. An investi-

gation as one changes the distance between the illumination-measuring device and the source will usually show whether or not the illumination is fairly independent of distance.

37. Hemispherical Source from the Inside.—The illumination received from the inside of a constant-brightness hemisphere upon the center of the plane of the great circle bears a very close relationship to the case of the infinite-plane source just considered.

The solid-angle form of the integral illumination equation applies very well in this case. Equation (25) rewritten for dE_p gives

$$dE_p = B \cos \beta \, d\omega \quad (67)$$

where $d\omega$ is the differential solid angle that a differential portion of the source subtends from the point P . This differential angle is the area $2\pi D^2 \sin \theta \, d\theta$ divided by D^2 of the hemisphere, or in terms of the linear angle θ ,

$$d\omega = 2\pi \sin \theta \, d\theta \quad (68)$$

Since $\beta = \theta$ in Fig. 52,

$$dE_p = 2\pi B \cos \theta \sin \theta \, d\theta \quad (69)$$

The total illumination at P is

$$E_p = 2\pi B \int_0^{\pi/2} \cos \theta \sin \theta \, d\theta \quad (70)$$

$$= \pi B \sin^2 \theta \Big|_0^{\pi/2} \quad (71)$$

$$E_p = \pi B \quad (72)$$

As for the plane source of infinite extent, the illumination is dependent only upon the brightness of the source. Obviously in the limit of the boundary conditions the two cases are the same.

If the illumination equation with the angle θ as the variable is applied to the plane infinite source, the integral form will be identical with equation (70). This can be easily demonstrated

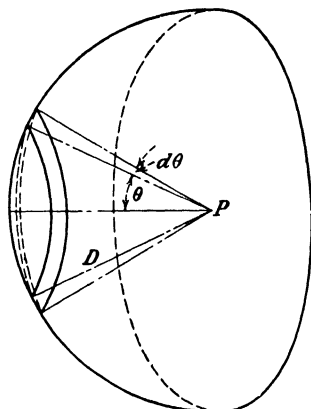

FIG. 52.—Hemispherical source.

by referring to Fig. 51. Instead of using r and dr as the variable and differential, let the angle θ and the corresponding differential $d\theta$ be employed. Then $dA = 2\pi D^2 \tan \theta d\theta$. (In this example D was a variable distance.) Substituting in the illumination equation (17) gives

$$E_p = 2\pi B \int_0^{\pi/2} \cos \theta \sin \theta d\theta \tag{73}$$

which is the same equation as (70) for the hemisphere. It should be noted that in equation (70) the radius of the hemisphere is of no importance. Likewise in equation (73) the distance q from the point P to the plane does not appear. This is to be expected if one interprets the differential illumination as the result of a luminous differential source subtended by the solid differential angle $d\omega$. The hemispherical case has been con-

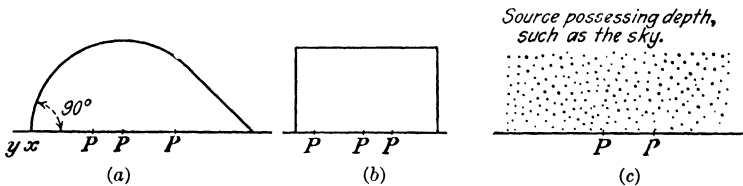

Fig. 53.—Several sources effective in producing an illumination of πB .

sidered, since it lends itself to an evaluation of $d\omega$ very readily. With this example of a specific case we can now proceed to the general case that the configuration of the surface is of absolutely no importance if the brightness distribution as viewed from the point P remains constant. Thus the point P might just as well have been at any point on the great circle as at the center; or the source could have been of any configuration with the same boundary conditions. Figure 53 illustrates several sources that would produce the same illumination at the various positions of P as would the infinite-plane source, provided the brightness of the luminous sources were the same.

In the case of sources such as in Fig. 53a and b the illumination at P becomes discontinuous as the point P approaches a boundary such as at x in Fig. 53a. The illumination at P_x would be only $\frac{1}{2}\pi B$ if the angle of the side of the source were 90 deg. in one plane as indicated. Outside the source, as at y , the illumination due to the interior of the source would obviously be zero. If the point P falls in a corner of the source such as at the intersection of

three planes the proper boundary conditions should be placed on the integral and the integration performed and evaluated. The polar coordinates used in the examples thus far would probably be insufficient, depending somewhat upon the exact configuration of the source.

38. Circular-disk Source.—The illumination resulting from a perfectly diffusing circular plane disk, or from any perfectly diffusing source possessing a circular boundary from the point of

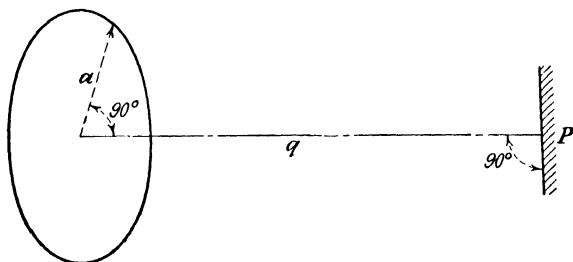

FIG. 54.—A circular disk with P on the axis and upon a parallel plane.

observation P , may be determined by evaluating equation (65) over the limits of zero to a rather than to infinity, where a is the radius of the disk. Thus

$$E_p = -\pi q^2 B (r^2 + q^2)^{-1} \Big|_0^a \tag{74}$$

$$= \pi B \frac{a^2}{a^2 + q^2} \tag{75}$$

This illumination is that upon a plane parallel to the disk source

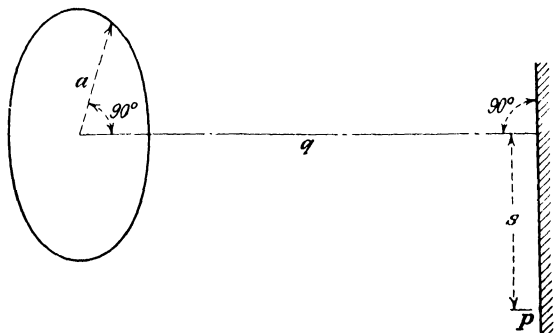

FIG. 55.—A circular disk with P not on the axis but upon a parallel plane.

(or a circular-boundary source) and upon a line perpendicular to the center of the source.

The illumination is often desired at a point P not upon the axis of the circular disk. If the point is displaced a distance s from the axis position but still upon a plane parallel to the disk, the illumination can be shown to be

$$E_p = \frac{\pi B}{2} \left[1 + \frac{a^2 - q^2 - s^2}{\sqrt{(q^2 + s^2 + a^2)^2 - 4a^2s^2}} \right] \quad (76)$$

Equation (75) is obviously a special case of equation (76) with s equal to zero. A plot of equation (76) for various ratios of

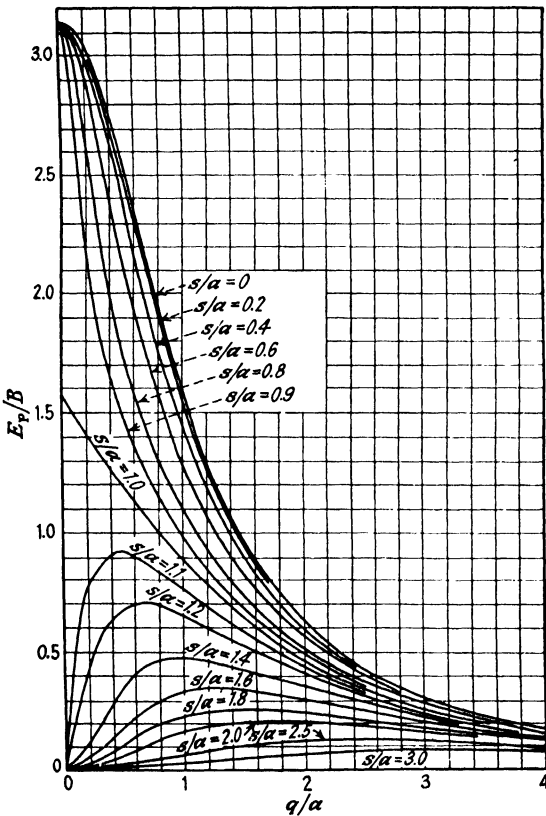

FIG. 56.—Plot of variables of equation (76). (Circular disk source on a parallel plane.)

E_p/B , q/a , and s/a is given in Fig. 56. The curve for s/a equal to zero is also the plot of equation (75).

The value of E_p/B in Fig. 56 always becomes π for ratios of s/a less than unity as the ratio q/a goes to zero. This is to be expected, since with s less than a the point P approaches the source. The flux density (or illumination) received at P then is identical with the flux density (or luminosity) of the source. Since the luminosity and brightness of the perfectly diffusing source are related through π , the value of E_p should also be πB .

For s/a greater than unity the value of E_p/B always becomes zero as the ratio q/a goes to zero. This likewise is to be expected, since the point P then misses the source completely.

For s/a equal to unity the equation of q/a equal to zero is indeterminate in form, but by calculus methods E_p/B may be shown to be equal to $\pi/2$. This is logical, since with the point P on the exact boundary of the source, the contribution of the source to illumination at P is only half as effective as with the point P within the boundary.

The curves of Fig. 56 may be applied to sources that do not subtend complete circular disks by the method of subtraction of illuminations.

For example, in Fig. 57 the diffusing circular-ring luminous coffer source has an outer radius of $a_1 = 4.5$ ft. and an inner radius of $a_2 = 2.5$ ft. The distance q is 9 ft. The direct illumination at a point displaced 6.5 ft. from the center of the source is desired for a uniform source brightness of 1.5 candles per square inch. Converting all dimensions to correspond to a linear measure in feet gives

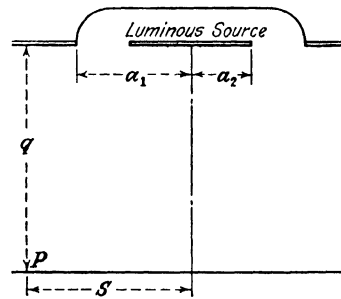

FIG. 57.—Example of subtractive method of illumination determination.

$a_1 = 4.5$	$q/a_1 = 2.00$	
$a_2 = 2.5$	$q/a_2 = 3.60$	
$q = 9.0$	or	$s/a_1 = 1.44$
$s = 6.5$		$s/a_2 = 2.60$
$B = 216$		

If the source were complete with a radius of a_1 the ratio of E_p/B from Fig. 56 would be 0.34. However, if the source

possessed a radius of a_2 , the ratio of E_p/B as obtained from the same figure would be 0.11. The difference of these values, or 0.23, yields the ratio of E_p/B which results with only the ring as the source. Consequently the illumination at P is 0.23×216 , or 50 lumens per square foot.

39. Rectangular Source.—The illumination resulting from a perfectly diffusing rectangular source may be determined by performing the integration process over the proper boundary limits. The rectangular coordinate system will be used because

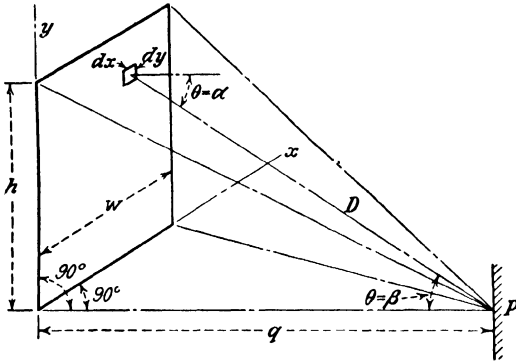

FIG. 58.—A rectangular source with the point P on a perpendicular erected at one corner of the source and on a parallel plane.

of the nature of the boundaries. This results in the evaluation of a double integral.

Two cases will be considered. First, the receiver plane will be taken parallel to the plane of the source (or its equivalent boundary), and second, the receiver plane will be taken perpendicular to the plane of the source but parallel to one of its edges.

In Fig. 58 the differential area dA is $dx dy$, the value of D^2 is $x^2 + y^2 + q^2$, and $\cos \alpha = \cos \beta = \cos \theta = q/\sqrt{x^2 + y^2 + q^2}$.

The differential illumination at P due to dA is

$$dE_{p-y} = \frac{Bq^2}{(x^2 + y^2 + q^2)^2} dx dy \tag{77}$$

and the total illumination at P due to the complete source is

$$E_{p-y} = Bq^2 \int_{y=0}^{y=h} \int_{x=0}^{x=w} \frac{dx dy}{(x^2 + y^2 + q^2)^2} \tag{78}$$

The integration and substitution of limits yields

$$E_{p_{z-y}} = \frac{B}{2} \left(\frac{h}{\sqrt{h^2 + q^2}} \sin^{-1} \frac{w}{\sqrt{w^2 + h^2 + q^2}} + \frac{w}{\sqrt{w^2 + q^2}} \sin^{-1} \frac{h}{\sqrt{w^2 + h^2 + q^2}} \right) \quad (79)$$

The double subscripts on the illumination symbol indicate the plane upon which the illumination is being considered. The source in both cases is taken in the $x - y$ plane.

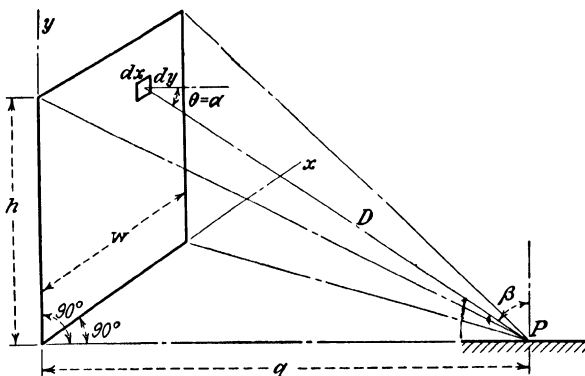

FIG. 59.—A rectangular source with the point P on a perpendicular erected at one corner of the source and on a plane passing through one edge of the source.

In Fig. 59 the differential area dA is $dx dy$, the value of D^2 is $x^2 + y^2 + q^2$, $\cos \alpha = \cos \theta = q/\sqrt{x^2 + y^2 + q^2}$, and

$$\cos \beta = y/\sqrt{x^2 + y^2 + q^2}.$$

The differential illumination at P due to dA is

$$dE_{p_{z-z}} = \frac{Bqy}{(x^2 + y^2 + q^2)^2} dx dy \quad (80)$$

and the total illumination at P due to the complete source is

$$E_{p_{z-z}} = Bq \int_{y=0}^{y=h} \int_{x=0}^{x=w} \frac{y dx dy}{(x^2 + y^2 + q^2)^2} \quad (81)$$

The integration and substitution of limits yields

$$E_{p_{z-z}} = \frac{B}{2} \left(\tan^{-1} \frac{w}{q} - \frac{q}{\sqrt{h^2 + q^2}} \sin^{-1} \frac{w}{\sqrt{w^2 + h^2 + q^2}} \right) \quad (82)$$

Again the double subscripts on the illumination symbol indicate that the illumination is upon the $z - x$ plane.

Since w and h may be interchanged without affecting the validity of the general geometry of the receiver plane being perpendicular to the plane of the source and passing through one edge of the source, the illumination with the point P on the

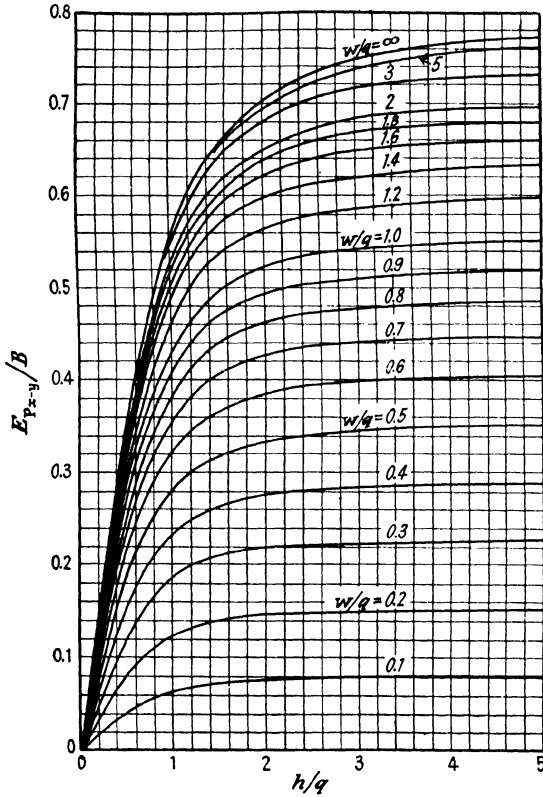

FIG. 60.—Plot of variables of equation (79). (Rectangular source on a parallel plane.)

$y - z$ plane may be written by inspection from equation (82). If the point maintains the same position as in Figs. 58 and 59, the substitution of $-h$ for w and $+w$ for h in equation (82) would be necessary, since h as a limit on x in this equation would be negative whereas w as a limit on y would be positive. Hence

$$E_{P_{y-z}} = \frac{B}{2} \left(-\tan^{-1} \frac{h}{q} + \frac{q}{\sqrt{w^2 + q^2}} \sin^{-1} \frac{h}{\sqrt{w^2 + h^2 + q^2}} \right) \quad (83)$$

Figure 60 shows the plot of certain ratios of the variables of equation (79). The upper curve of this figure represents the condition of an infinite half strip h units wide. If this curve were extended to very large values of h/q , the ratio should approach $\pi/4$, since then the illumination at P would be that

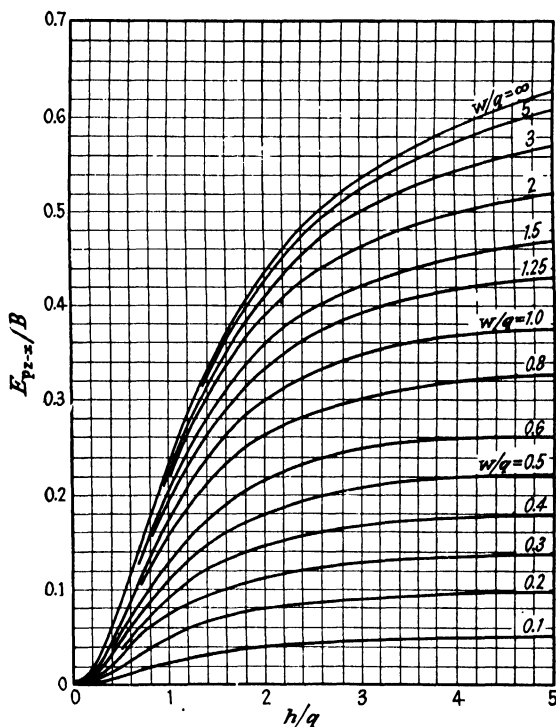

FIG. 61.—Plot of variables of equation (82). (Rectangular source on a perpendicular plane.)

derived from one-fourth of a source of infinite extent as of Art. 36. It may be noted that at h/q equal to 5 the ratio of illumination to brightness is approximately only 2 per cent less than $\pi/4$ and the slope of the curve is not yet zero.

The plot of similar ratios of variables from equation (82) is given in Fig. 61. Again the upper curve represents the condition of an infinite half strip h units wide.

All the equations that have been discussed for the rectangular source have yielded the illumination upon some plane at a point

perpendicular to one corner of the source. Although general equations may be developed for the point P offset from the perpendicular, the preceding charts may be used directly by the methods of illumination components.

First let the point P be upon a perpendicular to the source that falls *within* the boundary of the source as in Fig. 62.

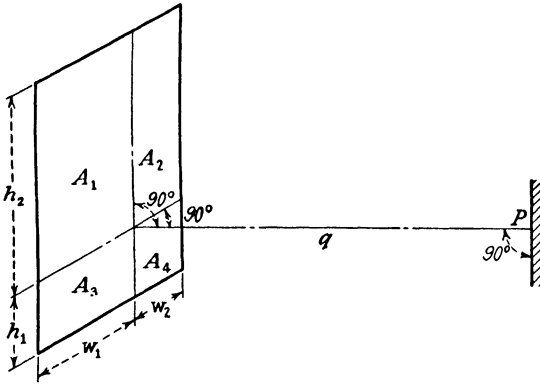

FIG. 62.—A rectangular source with the point P on a perpendicular erected within the boundary of the source and on a parallel plane.

For example, let the following values be known:

$$\begin{array}{ll}
 w_1 = 3.5 \text{ ft.} & w_1/q = 0.70 \\
 w_2 = 1.5 \text{ ft.} & w_2/q = 0.30 \\
 h_1 = 1.3 \text{ ft.} & \text{or } h_1/q = 0.26 \\
 h_2 = 5.5 \text{ ft.} & h_2/q = 1.10 \\
 q = 5.0 \text{ ft.} & \\
 B = 1.7 \text{ candles/sq. in.} &
 \end{array}$$

If the area A_1 alone were luminous, the illumination at P would be $0.370 \times 1.7 \times 144$ ft.-candles as from Fig. 60. If A_2 alone were effective, the illumination would be $0.195 \times 1.7 \times 144$ ft.-candles. If A_3 alone were effective, the illumination would be $0.130 \times 1.7 \times 144$ ft.-candles. And finally, if A_4 alone were effective, the illumination would be $0.055 \times 1.7 \times 144$ ft.-candles. Obviously the illumination at P due to the whole luminous source would be the sum of these values, or

$$0.750 \times 1.7 \times 144 = 184 \text{ ft.-candles.}$$

If the point P had been on a perpendicular to the source that falls upon one edge of the luminous source but not upon a corner,

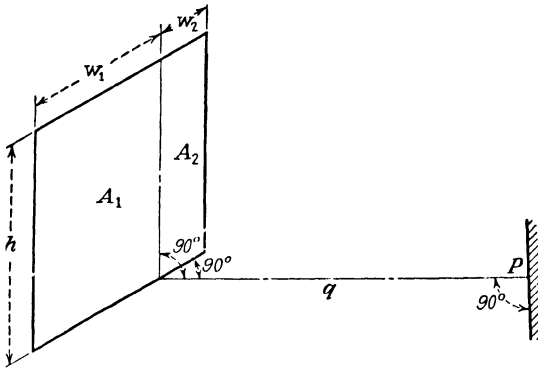

FIG. 63.—A rectangular source with the point P on a perpendicular erected from a point along one edge of the source and on a parallel plane.

the summation of two component illuminations would be necessary. Such a case is shown in Fig. 63.

Finally the point P may be upon a perpendicular to the source that falls *outside* the boundary of the source as the area A_{1234} of

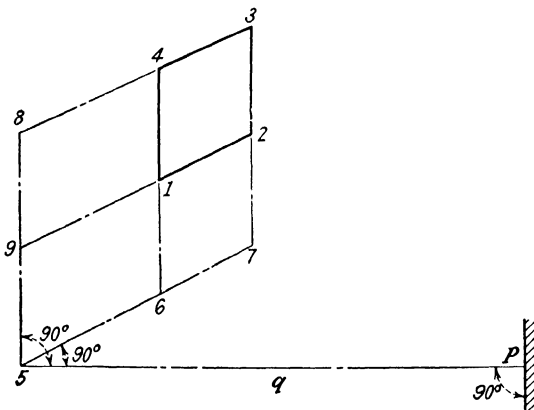

FIG. 64.—A rectangular source with the point P on a perpendicular erected outside the boundary of the source and on a parallel plane.

Fig. 64. Again the component method of computation may be employed. If the total area A_{5738} were luminous, the illumination at P can be determined from the plot of Fig. 60. If from this value the illumination due to the area A_{5648} is subtracted,

the remainder gives the illumination due to the area A_{6734} . This includes the area that is truly luminous but also that due to A_{6721} . Two components must be considered in order to subtract the effect of this latter area. The illumination caused by A_{6721} is that due to A_{5729} less that due to A_{5619} . Subtracting this net result from the illumination due to A_{6734} yields the illumination due to the area A_{1234} . Placing the subscripts directly upon the illuminations and writing as an equation gives

$$\begin{aligned} E_{1234} &= E_{5738} - E_{5648} - (E_{5729} - E_{5619}) \\ &= E_{5738} - E_{5648} - E_{5729} + E_{5619} \end{aligned} \tag{84}$$

40. Strip Source.—The illumination caused by a narrow rectangular source can be determined from the methods just

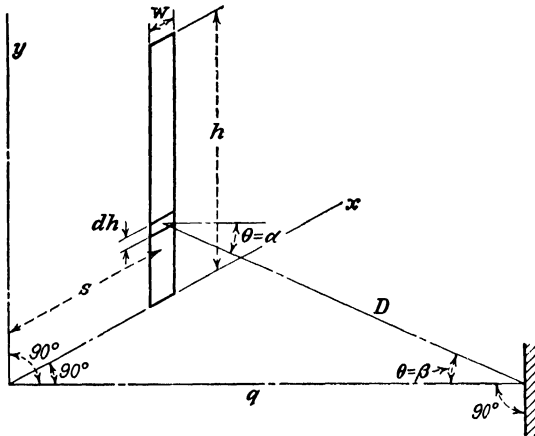

FIG. 65.—A strip source with the point P on a perpendicular erected from a point displaced a distance s from one end and on a parallel plane.

considered. However, in some cases the illumination components may be relative large numbers with small differences. Such conditions yield very inaccurate results unless computations from the formulas are carried out to many more significant figures than the final result is to possess. Consequently the case of the strip source will be developed independently with the restriction that the width will be small with respect to the distance D . A semi-general case will be considered in which the point P will be displaced from the source in the direction of its narrow width but will be on a perpendicular to the line through

one end of the source. Figure 65 illustrates the geometry of the case where P is on a parallel plane.

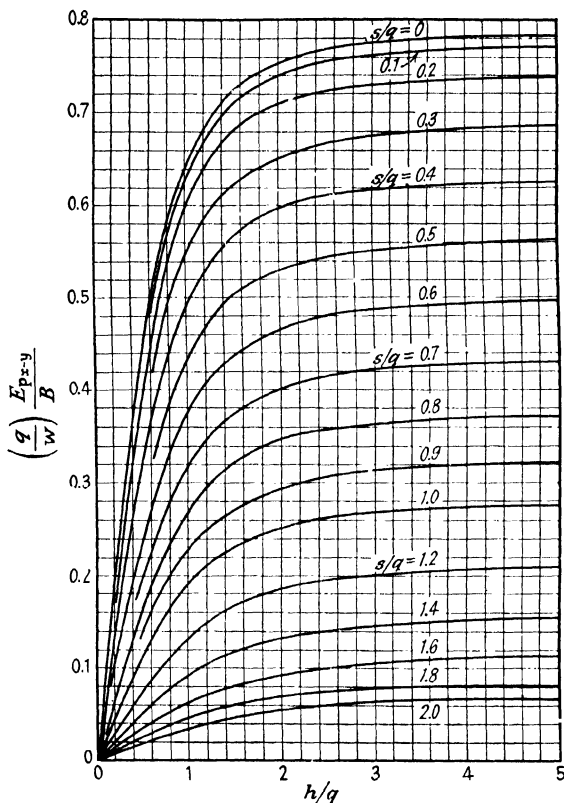

FIG. 66.—Plot of variables of equation (87). (Strip source on a parallel plane.)

In the figure the differential area dA is $w dy$, the value of D^2 is $s^2 + y^2 + q^2$, and $\cos \alpha = \cos \beta = \cos \theta = q/\sqrt{s^2 + y^2 + q^2}$. The differential illumination at P due to dA is

$$dE_{p_x-y} = \frac{Bq^2w}{(y^2 + s^2 + q^2)^2} dy \quad (85)$$

and the total illumination at P due to the complete source is

$$E_{p_x-y} = Bq^2w \int_0^h \frac{dy}{(y^2 + s^2 + q^2)^2} \quad (86)$$

The integration and substitution of limits yields

$$E_{p_{z-y}} = \frac{Bq^2w}{2(s^2 + q^2)} \left[\frac{h}{(s^2 + q^2 + h^2)} + \frac{1}{\sqrt{s^2 + q^2}} \tan^{-1} \frac{h}{\sqrt{s^2 + q^2}} \right] \quad (87)$$

The plot of the ratio of the variables h/q and s/q as determining the magnitude of the cause-and-effect phenomena is given in Fig. 66. However, in this case a complete isolation of the ratios h/q and s/q is not possible. Since the ratio of w/q enters as a direct multiplier, this term is transferred to the ordinate scale and included in the plot as $(q/w)(E_{p_{z-y}}/B)$.

An example will illustrate the use of the chart. In Fig. 67 the source is a continuous strip luminaire consisting of an enclos-

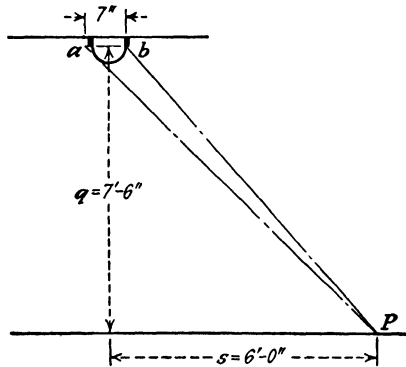

FIG. 67.—Example of luminous strip source.

ing diffusing glassware about fluorescent lumiline lamps. The brightness of the glassware is known to be essentially constant at 1.1 candles per square inch. The point P is on a working plane 7 ft. 6 in. below the light center and displaced 6 ft. to one side. From the point P the source is equivalent to a rectangular source of 7-in. width (ab in the figure). The source extends 8 ft. in one direction and 24 ft. in the other from the plane of the figure.

Considering first the 8-ft. length as one component of the source,

$$\begin{array}{ll}
 h_1 = 8.0 & \\
 q = 7.5 & h_1/q = 1.07 \\
 s = 6.0 & \text{or } s/q = 0.8 \\
 w = 0.583 & q/w = 12.85 \\
 B = 1.1 \times 144 &
 \end{array}$$

Entering the chart at the values of h_1/q and s/q , the value of $(q/w)(E_{p_{x-y}}/B)$ is found to be 0.282. Substituting for the known conditions of q/w and B_1 gives

$$E_{p_{x-y}} = 0.282 \times 1.1 \times 144/12.85 = 3.5 \text{ ft.-candles.}$$

Considering next the 24-ft. length as the other component of the source,

$$\begin{array}{ll}
 h_2 = 24.0 & \\
 q = 7.5 & h_2/q = 3.2 \\
 s = 6.0 & \text{or } s/q = 0.8 \\
 w = 0.583 & q/w = 12.85 \\
 B = 1.1 \times 144 &
 \end{array}$$

Entering the chart at the value of h_2/q and s/q , the value of $(q/w)(E_{p_{x-y}}/B)$ is found to be 0.365. Again substituting the known conditions of q/w and B gives

$$E_{p_{x-y}} = 0.365 \times 1.1 \times 144/12.85 = 4.5 \text{ ft.-candles.}$$

The total illumination with both sections of continuous luminous source acting is the sum of these component values, or 8.0 ft.-candles.

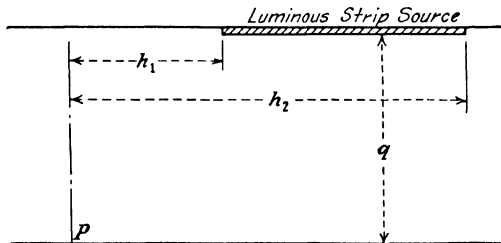

FIG. 68.—Example of continuous strip source not extending to the point P .

If the source does not extend lengthwise as far as the point at which the illumination is desired, the component method may also be used. Figure 68 shows a longitudinal view of such a case. The point P may be either in the plane of the figure or

not. The illumination due to a continuous strip of the same brightness and width as the actual strip but extending the full length h_2 should first be determined. If the source is the same, the distance $h_2 = 24$ ft., $s = 6.0$ ft., and $q = 7.5$ ft., as in the preceding example, the illumination would be 4.5 ft.-candles as before.

If the actual source is 16 ft. in length, then h_1 would be 8 ft. as in the preceding example. The illumination due to this length of source was shown to be 3.5 ft.-candles. Consequently the illumination from the actual 16 ft. of luminous strip source is $4.5 - 3.5$, or 1.0 ft.-candle, at the point P where P is displaced sideways 6 ft. from the line of the source.

41. General Source of Irregular Shape.—Various plans of attack can be devised for approaching the problem of irregular-shaped sources. Higbie has suggested that the source be considered divided into parallel contiguous strips, each of which be treated according to methods very similar to Art. 40. Others have devised a mechanical integrator to be used with a model of the source. Still another method, devised by Greenberg, is a device involving a special series of scales to be applied to a scale drawing of the source.

Further development of these and other methods is beyond the scope of this text; but for detailed information on the methods mentioned above, references to articles by Cherry *et al.*, Greenberg, and Higbie will be found at the end of the chapter.

Problems

1.7. The illumination on a horizontal plane outdoors with no obstructions to any part of the sky is measured and found to be 750 ft.-candles on a cloudy day with no direct sunlight. If the sky is assumed to be of constant brightness at all positions, what is that brightness in candles per square inch?

2.7. A circular ring coffer similar to that of Fig. 57 has an outer radius a_1 of 6 ft. 8 in. and an inner radius a_2 of 4 ft. 8 in. The distance q is 8 ft., and the distance s is 4 ft. An illumination at the point P of 30 ft.-candles is desired. What must be the brightness of the luminous portion of the source expressed in candles per square inch?

3.7. A window 32 in. wide by 48 in. high is located in a vertical wall 28 in. above the floor. A desk 30 in. high is located in the interior of the room. What is the illumination upon the horizontal surface of this desk at a point 5 ft. from the outer wall in which the window is located and displaced 2 ft. from one edge of the window? The window is open to an unobstructed, clear north sky possessing a brightness that is assumed uniform at its average value of 1 candle per square inch.

4.7. What would be the illumination in Prob. 3.7 if the sky of all but the upper 18 in. of the window from the point of view of the point P were obscured by a very dark building located close by?

5.7. Diffusing panels 12 in. wide and 32 ft. long are located at a ceiling height of 10 ft. above the floor in an office room as shown in the accompany-

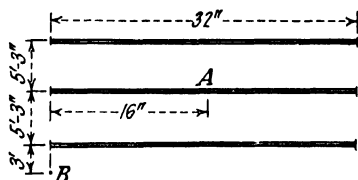

FIG. 69.

ing plan. The brightness of the panels is 1.15 candles per square inch. What is the direct illumination from the strips at the points A and B on the top of desks 30 in. above the floor?

REFERENCES

- H. H. Higbie, "Lighting Calculations," John Wiley & Sons, Inc., New York, 1934.
- P. Moon, "The Scientific Basis of Illuminating Engineering," McGraw-Hill Book Company, Inc., New York, 1936.
- V. H. Cherry, D. D. Davis, and L. M. K. Boilter, A Mechanical Integrator for the Determination of the Illumination from Diffuse Surface Sources, *Trans. Illum. Eng. Soc. (N.Y.)*, **34**, 1939, pp. 1085-1094.
- E. H. Wakefield, A Simple Graphical Method of Finding Illumination Values from Tubular, Ribbon, and Surface Sources, *Trans. Illum. Eng. Soc. (N.Y.)*, **35**, 1940, pp. 142-150.
- B. F. Greenberg, A Device for the Determination of Illumination, *Trans. Illum. Eng. Soc. (N.Y.)*, **35**, 1940, pp. 629-635.
- W. Foulks, The Application of Continuous Source Luminaires, *Trans. Illum. Eng. Soc. (N.Y.)*, **35**, 1940, pp. 786-794.
- H. H. Higbie, Prediction of Illumination at a Point from Source of Any Shape, *Trans. Illum. Eng. Soc. (N.Y.)*, **36**, 1941, pp. 79-98.

CHAPTER 8

ABSORPTION, REFLECTION, AND TRANSMISSION OF LUMINOUS FLUX

<i>Symbol</i>	<i>Term</i>	<i>Definition</i>
	Primary luminous source	A source that is luminous by virtue of incandescence, luminescence, fluorescence, or phosphorescence.
	Secondary luminous source	Any source that is luminous by virtue of reflection or transmission of luminous flux from or through the surface.
	Specular	An ideal specular surface reflects all luminous flux received by it at an angle of reflection equal to the angle of incidence.
	Diffuse	An ideal diffuse surface or transmitting medium reflects or transmits all luminous flux in such a geometric manner that the brightness of the surface is constant.
	Glare	A subjective effect—the result of two or more surfaces that possess radically different brightnesses in the direction of the observer.
ρ_{λ}	Spectral reflection factor	Ratio of the spectral emission to the spectral irradiation where the surface acts as a secondary luminous source due to reflection.
ρ	Reflection factor	Ratio of the luminosity at a point on the surface due to reflection to the illumination at the same point on the same surface.
τ_{λ}	Spectral transmission factor	Ratio of the spectral emission to the spectral irradiation where the surface of the transmitting medium acts as a secondary luminous source.
τ	Transmission factor	Ratio of the luminosity at a point on the surface due to transmission to the illumination at the closest point on the opposite side of the same medium.

42. General.—Sources have been considered thus far with very little reference as to whether they were primary or secondary sources of radiation. Incandescent bodies, certain gas chambers in the process of conduction of electricity, and fluorescent and phosphorescent bodies constitute the possibilities of primary sources. Transparent and translucent bodies having either a

primary or another secondary source on one side constitute secondary sources when viewed from the opposite side. Practically all materials—translucent, opaque, or so-called *transparent*—act as secondary sources when viewed from the same side that is receiving radiation from a primary or another secondary source. This chapter deals with secondary sources.

43. Absorption.—Consider a surface that is illuminated from another source—either primary or secondary. Some of the radiant energy received by this surface will be absorbed by the body and act to raise the temperature of the body. If the body whose surface is under consideration is opaque, there will be no transmission of radiant energy having wave lengths between 0.40 and 0.76μ through the body. Some radiant energy having wave lengths in this region may be given off by the body from the same side as that at which received. It is thought that neither of the processes—transmission or reflection—can be absolutely complete. Some energy is lost in the process.

In treating conditions from an illumination-engineering viewpoint, radiant energies, or radiant-power densities, will not be considered as such. Rather these items will be evaluated through the luminosity function. Hence we shall be concerned *not* with the amount of *energy* absorbed but with the amount of *light* absorbed.

Generally, materials are not analyzed on the basis of their absorption of light, but rather upon their transmitting and reflecting properties. It is well to bear in mind, when studying reflecting and transmitting phenomena of inactive bodies, that the difference of the light received over a given area in some time interval and that transmitted and reflected from the same area in the same time interval is accounted for by the absorption (or loss), which may be large or small but is not absolutely 100 per cent or 0 per cent.

44. Reflection.—Consider now a material that may or may not be capable of transmitting any appreciable light through the body. The surface of such a body will in general reflect some of the light received from another source. We shall be concerned with the manner in which this light is reflected from the surface—both geometrically and spectroradiometrically.

If an element of this surface is receiving luminous flux from a very small source with respect to the distance from the source

to the element, the luminous flux may be considered as received at some definite angle with the normal to the plane of the element. For example, in Fig. 70 the source at *S* radiates luminous flux

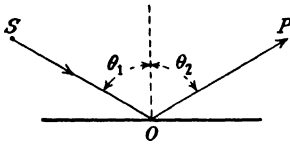

FIG. 70.—Specular reflection.

which is received at ΔA at an angle of θ_1 . If this flux is reflected at an angle with the normal equal to that of incidence, the surface is said to be *specular*. The ideal specular surface is one that reflects all the luminous flux received by the element of surface ΔA

at an angle of reflection exactly equal to the angle of incidence.

If the surface is a perfect specular surface, the observer at *P* would have no knowledge that the surface existed in the region of the point *O*. Instead, the image of the source would appear to be along the line *PO* and at a distance equal to the sum of *PO* and *OS*. Actually there will usually be a certain amount of scattering of luminous flux from the surface, and hence the surface may be evident. Even with the best polished metal some of the luminous flux is absorbed in the reflection process. Hence the effect upon an illumination at *P* on a particular plane due to a source *S* having a designated brightness and projected area will be a reduction in the relationship for illumination as

$$E_p = k_1 \int_S \frac{B \cos \alpha \cos \beta dA}{D^2} \tag{88}$$

where k_1 is the ratio of the apparent brightness of the source from *P* along the path *POS* to that along the path *OS* direct from the source. This constant is approximately the reflection factor of the mirror. Reflection factor will be defined in Art. 45.

If, instead of a distribution of the luminous flux according to the manner of specular reflection, the distribution is in such a manner that the intensity of

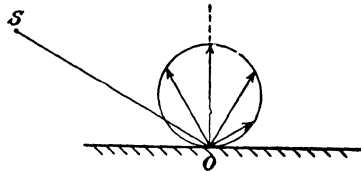

FIG. 71.—Intensity-distribution curve for diffuse reflection.

an element of surface ΔA behaves as a cosine function of the angle from the normal, the surface is said to be *diffuse*. Furthermore the distribution of flux is such that the same cosine function of intensity results regardless of the angle of incidence. Such was the condition discussed in Art. 31 of Chap. 6.

Obviously these two conditions are idealized. Actually no surface behaves in exactly one of these manners. However, the specular surface can be approximated by a polished metal mirror; and the diffuse surface can be approximated by a surface painted with a flat or mat paint.

Between the extreme limits of idealized specular and diffuse surfaces lie the actual surfaces found in nature. Terminology associated with these surfaces has not been very rigidly established. Indeed there is need for the establishment of better terminology. Mirror surfaces can be called the practical limit to which specular reflection can be approached. The term *mat*

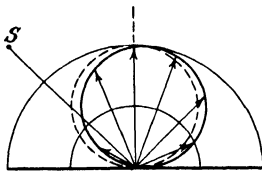

FIG. 72.—Mat-surface reflection.

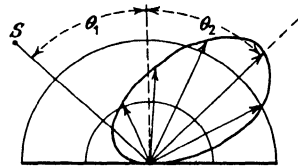

FIG. 73.—Semi-mat-surface reflection.

surface has been used to describe surfaces that most nearly approximate the ideal diffuse surface. The term *semi-mat* is often used to describe a surface which gives a rather continuous intensity distribution for a small element but which distributes more flux in the quadrant of the sphere on the opposite side of the normal from the source. Cross sections through the solids describing the intensities for all angles taken through the plane of the source are shown for several surfaces in Figs. 72 to 75.

The surface of Fig. 72 yields an intensity distribution from a small element of the surface which is approximately a polar plot of the cosine function. The brightness at any point on the surface from any angle of observation is practically constant. As a result the subjective effect—the brilliance of the surface—will likewise appear essentially the same from any angle of observation regardless of the size or the number of the sources. Hence such sources lend themselves to use as secondary sources of reflected light. Excessive brightness of one surface with respect to that of another surface or to another part of the same surface in the line of vision causes excessive subjective brilliance effects. When such excessive brilliance conditions occur to an individual, we say that the source of higher brilliance is “glaring.”

With mat surfaces reflected glare is usually a minimum that can be experienced.

The intensity distribution from the surface of Fig. 73 is regular but has a maximum value in the region of an angle of reflection equal to the angle of incidence. The brightness of such a source would be larger on the right-hand side of the vertical than on the left. However, the ratio of maximum brightness to minimum brightness may not be excessive and hence may not produce objectionable brightness ratios from various angles of observation. Rather smooth mat surfaces exhibit this characteristic of reflection.

Any actual surface may behave radically differently from what is expected when the angle of incidence is very large. Such

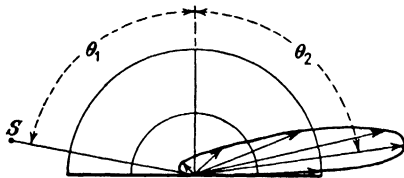

FIG. 74.—Semi-mat-surface reflection at large angle of incidence.

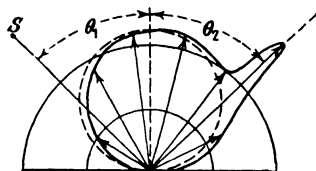

FIG. 75.—Porcelain-enameled steel reflection.

a radical condition as is illustrated in Fig. 74 may occur even on a mat surface, although the effect is usually more pronounced on a semi-mat surface. Here the ratio of maximum to minimum brightness may be quite large.

Other surfaces may behave approximately like diffuse surfaces for all angles of observation except angles of reflection essentially the same as the angle of incidence. For such angles the intensity distribution for an element of the surface may exhibit values that are decidedly greater than those for a diffuse surface. Such a possibility is illustrated in Fig. 75 for porcelain-enameled steel. If a large extent of such a surface is illuminated fairly uniformly by a rather small source, a fixed observer notes a rather small spot of excessive brilliance at that part of the surface where the angles of reflection and the angle of incidence are essentially the same. At other regions on the surface the brightness is essentially constant (and smaller than that at the region just described), and hence the brilliance of the remainder of the surface appears nearly constant.

45. Reflection Factor.—If a homogeneous radiation of wave length λ impinges upon a surface, the distribution of luminous flux from a small element of this surface will behave geometrically as has been discussed in the preceding article, depending upon the nature of the surface. If this surface acts as a simple secondary source, the radiant power reflected by the surface will be of the same wave length as that of the radiation received. The ratio of the radiant-power density reflected to that received at a point on the surface is defined as ρ_λ , the *spectral reflection factor at the wave length λ* . Thus

$$\rho_\lambda = \frac{J_\lambda}{G_\lambda} \quad (89)$$

where ρ_λ = spectral reflection factor at a wave length λ .

J_λ = reflected spectral emission at a wave length λ .

G_λ = spectral irradiation at a wave length λ .

If a homogeneous radiation of another wave length λ' is received in the region of the same point on the surface, the spectral reflection factor for this wave length will be the ratio of the homogeneous emission of wave length λ' to the homogeneous irradiation of the same wave length. By considering such conditions for a great number of wave lengths over the range of 0.40 to 0.76 μ the manner in which the surface behaves spectroradiometrically can be investigated. A surface that has a fairly constant and also a fairly large ρ_λ over the range of wave length previously mentioned is said to be a white surface. A surface that has a ρ_λ that is fairly constant but of smaller magnitude over the range considered is said to be a gray surface. And finally a surface that has a ρ_λ that is fairly constant but very small over the same range is said to be a black surface. Thus a plot of ρ_λ as a function of wave length for the three nonselective surfaces mentioned would appear as in Fig. 76, where curves *a*, *b*, and *c* would represent the white, gray, and black surfaces, respectively. The manner in which the spectral reflection factor behaves outside the range of wave lengths 0.40 to 0.76 μ has no significance from an illumination viewpoint unless some effect can be utilized through fluorescent or phosphorescent phenomena or through other phenomena not yet discovered.

The three surfaces considered in Fig. 76 were special surfaces. A more general case would be a surface exhibiting a spectral-

reflection-factor relationship such as is shown in Fig. 77. The particular graph represents the spectral reflection relationship for a red surface. Various limits of wave lengths have been

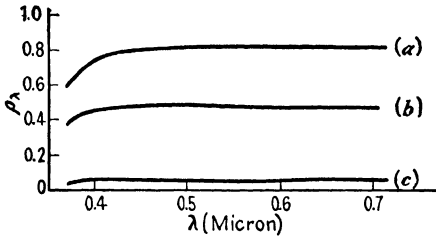

FIG. 76.—Spectral reflection factors for several fairly nonselective surfaces.

recommended at various times in order to specify objectively what conditions for the average individual yield the subjective spectral hues of red, orange, yellow, green, blue, and violet. One such recommendation is given in Table 4.

TABLE 4.—WAVE-LENGTH BOUNDARIES OF THE VARIOUS SPECTRAL HUES FOR THE AVERAGE INDIVIDUAL.

Hue	Wave-length Spread, Microns
Red.....	0.76–0.63
Orange.....	0.63–0.59
Yellow.....	0.59–0.55
Green.....	0.55–0.49
Blue.....	0.49–0.45
Violet.....	0.45–0.40

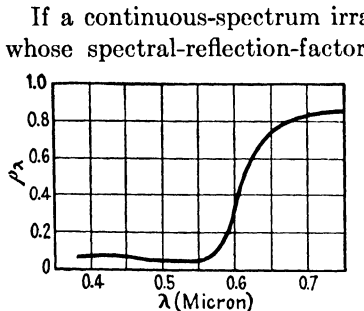

FIG. 77.—A spectral-reflection-factor graph for a red surface.

If a continuous-spectrum irradiation impinges upon a surface whose spectral-reflection-factor variation with wave length is known, a product of the two curves yields the emission of the surface as a secondary source. If this emission is evaluated now through the luminosity function, the resulting area under the curve will be the luminosity as specified earlier by equation (38a) of Chap. 4. The complete procedure is illustrated in Fig. 78.

However, there is no reason why the irradiation cannot be evaluated through the luminosity function first, thus giving

the illumination upon the surface. Then this illumination may be evaluated through the spectral-reflection conditions; *i.e.*, the operation by ρ_λ and v_λ can be interchanged without changing the end effect, which is the luminosity. If such a procedure is followed for the same G_λ vs. λ characteristic of Fig. 78 the results would be as illustrated in Fig. 79, where the final graph and area under the curve is identical with that of the final graph of Fig. 78.

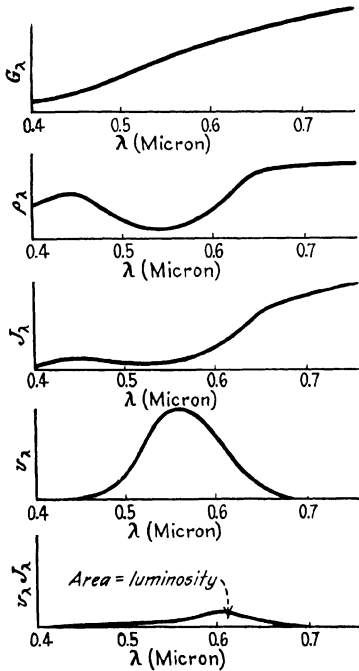

FIG. 78.—Process of evaluating luminosity through the emission due to reflection.

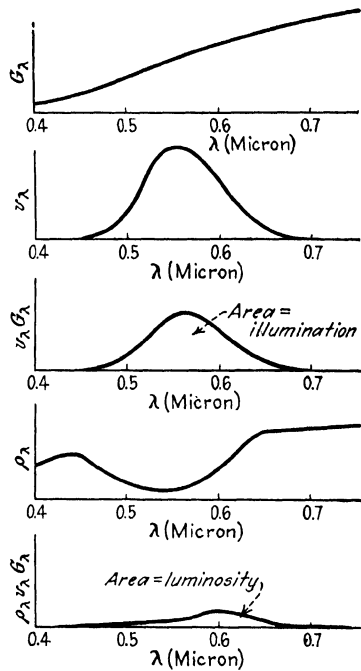

FIG. 79.—Process of evaluating luminosity of a reflecting surface through a previous evaluation of illumination from the irradiation.

Thus far the discussion of reflection from a spectroradiometric viewpoint has centered upon the *spectral reflection factor* ρ_λ , which is defined at a particular wave length through power-density relationships. To specify completely the conditions of a reflecting surface spectroradiometrically requires a graph or a tabulation of ρ_λ against wave length. With such information it is always possible to arrive at the luminosity of the surface

due to reflected luminous flux through either of the two processes just outlined. However, it is often convenient to specify for a given surface and a given spectroradiometric distribution of illumination the ratio of luminosity to the illumination. Such a ratio is called the *reflection factor* of the surface for a particular type of illumination, which should be specified. Thus the reflection factor is

$$\rho = \frac{L}{E} \quad (90)$$

where ρ = reflection factor corresponding to the spectroradiometric distribution from which the illumination is derived.

L = luminosity due to reflection.

E = illumination.

The reflection factor then depends upon two items: *first*, the condition of the surface, which is specified through a plot of ρ_λ vs. λ , and, *second*, the spectral distribution of the illumination. To state simply that the reflection factor of some surface is a certain value has no meaning. For illumination derived from an incandescent tungsten-filament lamp operating at 2950°K. the reflection factor for some particular surface could be, for example, 63 per cent, whereas for illumination derived from a green fluorescent lamp the reflection factor of the *same* surface could be perhaps as high as 75 per cent or as low as 30 per cent depending upon the manner of variation of the spectral reflection factor with wave length. However, even with these restrictions it may *at times* be more convenient to work with a series of values of reflection factors for various illuminants than to work with spectral reflection factors. For a continuous-spectrum source the reflection factor represents the ratio of the areas under the $v_\lambda J_\lambda$ and $v_\lambda G$ curves, as of Fig. 79. An interpretation for line-spectrum sources can be made by replacing the integration processes by simple summation processes.

46. Transmission.—Much the same discussion as was applied to reflecting bodies can be carried over for analyzing conditions at the surface emitting luminous flux on a transmitting body. Consider first a body that transmits all the luminous flux received. If luminous flux is received at an angle of incidence θ_1 with the normal to the surface, and all of this flux leaves at an angle of

emergence θ_2 with the normal equal to θ_1 , this body is said to be perfectly transparent. Such a condition is illustrated in Fig. 80. If such conditions could exist, an observer at P would have no knowledge that the body existed in the region of the point O unless an edge of the body is at the point O . Because of refraction within the body the line OP will be displaced but parallel to SO' .

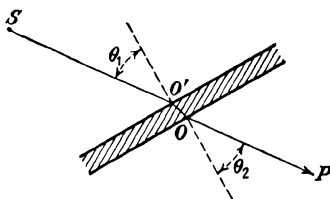

FIG. 80.—Transparent transmission.

Actually no substance transmits 100 per cent of the flux received. Hence the effect upon an illumination at P on a particular plane due to the source S whose brightness and geometry are known will be a reduction in the relationship for illumination similar to equation (42)

$$E_p = k_2 \int_S \frac{B \cos \alpha \cos \beta \, dA}{D^2} \tag{91}$$

where k_2 is the ratio of the apparent brightness of the source from P along the path $POO'S$ to that along the path SO' direct from the source. This constant is approximately the transmission factor of the more or less transparent body. Transmission factor will be defined in Art. 47.

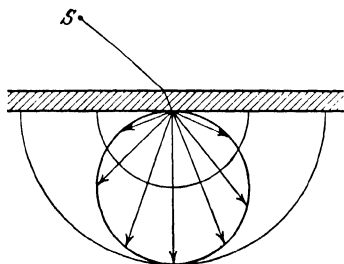

FIG. 81.—Diffuse transmission.

If instead of a distribution of luminous flux according to the manner of perfect transparency, the distribution is in such a manner that the intensity of an element of surface ΔA in the region of O behaves as a cosine function of the angle from the normal, the body is said to be a perfectly diffusing translucent body. Furthermore the distribution of flux is such that the same cosine function of intensity results regardless of the angle of incident light.

Again these two conditions are idealized. Actually no body behaves in exactly one of these manners. The perfect transparency can be approximated by a good quality of plate glass

and the perfectly diffusing translucent body can be approximated by certain types of so-called *opal glass*.

Plots of intensity distributions for elements of several translucent bodies are illustrated in Figs. 82 to 85. Solid opal glass is a very translucent milky white glass. The flashed opal is a transparent base with a thin layer of solid opal glass usually upon only one side of the base. The sand-blasted glass is a

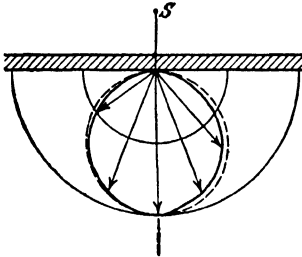

FIG. 82.—Solid opal glass transmission.

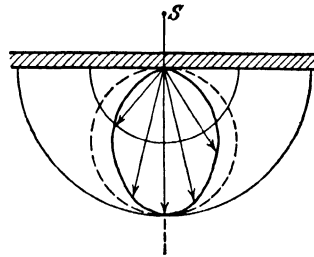

FIG. 83.—Flashed opal glass transmission.

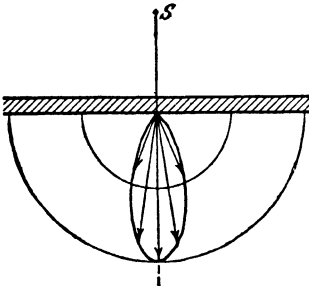

FIG. 84.—Sand-blasted glass transmission (source at 90 deg. from surface).

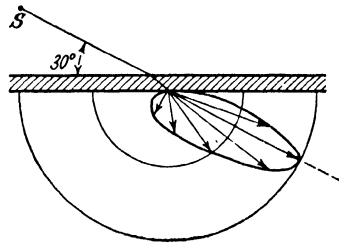

FIG. 85.—Sand-blasted glass transmission (source at 30 deg. from surface).

very much less diffusing glassware than the others as is indicated by Figs. 84 and 85.

47. Transmission Factor.—In a manner similar to that presented in Art. 45 the spectral transmission factor for a body may be defined as

$$\tau_{\lambda} = \frac{J_{\lambda}'}{G_{\lambda}} \quad (92)$$

where τ_{λ} = spectral transmission factor at a wave length λ .

J_{λ}' = transmitted spectral emission at a wave length λ .

G_{λ} = spectral irradiation at a wave length λ .

TABLE 5.—SPECTRAL TRANSMISSION FACTORS FOR SELECTED WRATTEN LIGHT FILTERS^a

Filter No.	2A	6	8	15	22	29	88	87	35	61	77
Name	K1	K2	G	E2	F	Infrared		D	N	
Wave length, micron											
0.20											
5											
0.30		0.14									
5	0.14							0.25		
0.40	0.09							0.48		
1	0.01	0.10							0.48		
2	0.54	0.12							0.45		
3	0.76	0.16							0.38		
4	0.83	0.21							0.26		
5	0.85	0.28							0.14		
6	0.86	0.38	0.02						0.05		
7	0.87	0.50	0.10						0.01		
8	0.88	0.63	0.25								
9	0.88	0.74	0.44							0.02	
0.50	0.88	0.82	0.59							0.18	
1	0.89	0.83	0.72	0.03						0.34	0.02
2	0.89	0.85	0.79	0.29						0.45	0.12
3	0.89	0.86	0.82	0.58						0.44	0.13
4	0.89	0.87	0.84	0.76						0.37	0.56
5	0.90	0.88	0.85	0.82	0.01					0.28	0.76
6		0.88	0.86	0.84	0.23					0.18	0.72
7		0.89	0.87	0.85	0.55					0.09	0.10
8		0.89	0.87	0.86	0.72					0.04	
9		0.89	0.88	0.87	0.83					0.01	
0.60		0.89	0.88	0.88	0.85						0.14
1		0.90	0.89	0.89	0.86	0.12					0.38
2			0.89	0.89	0.87	0.39					0.66
3			0.89	0.89	0.88	0.69					0.76
4			0.89	0.99	0.89	0.79					0.79
5			0.90		0.89	0.87			0.05		0.81
6					0.90	0.88			0.20		0.83
7						0.89			0.44		
8						0.90			0.63		
9									0.75		
0.70							0.01		0.81		
							0.05				
5							0.90	0.03			
0.80							0.95	0.55			
5								0.80			
0.90								0.90			
5								0.95			

(Good in infrared)

^a "Wratten Light Filters," 16th ed., 1940.

TABLE 6.—SPECTRAL TRANSMISSION FACTORS FOR SELECTED CORNING GLASS FILTERS^a

Filter No.	738	038	352	245	254	986	440	592	533	397	398
Wave length, micron											
0.20											
2											
4											
6						0.06					
8						0.36					
0.30						0.67					
2						0.80					
4						0.81					
6	0.58					0.77					
8	0.87					0.56	0.13				
0.40	0.91					0.13	0.33	0.80	0.86	0.58	0.11
2		0.09				0.01	0.48	0.87	0.83	0.60	0.15
4		0.69					0.58	0.70	0.73	0.64	0.20
6		0.78					0.65	0.73	0.59	0.67	0.22
8		0.83					0.70	0.69	0.39	0.69	0.26
0.50		0.85	0.10				0.68	0.83	0.22	0.70	0.29
2		0.86	0.69				0.61	0.60	0.12	0.70	0.30
4			0.79				0.48	0.84	0.06	0.68	0.29
6			0.84				0.30	0.87	0.05	0.65	0.28
8			0.86				0.17	0.10	0.04	0.60	0.25
0.60				0.40			0.09	0.50	0.03	0.57	0.22
2				0.80			0.05	0.88	0.02	0.52	0.20
4				0.85			0.03	0.90	0.02	0.46	0.16
6				0.86			0.02	0.90	0.02	0.40	0.12
8								0.84	0.03	0.34	0.08
0.70								0.88	0.05	0.27	0.05
2								0.90	0.16	0.21	0.02
4								0.35		0.15	0.01
1.0					0.60					0.03	
1.5					0.77					0.03	
2.0					0.71					0.15	0.02
2.5					0.71					0.19	0.02
3.0					0.47					0.10	
4.0					0.10					0.05	0.01
5.0											

^a"Glass Color Filters," Corning Glass Works Catalog C-206, 1941.

Spectral-transmission relationships are given for several transmitting media in Figs. 86 to 88.

The same procedure of evaluation of incident irradiation as was outlined in Fig. 78 could be applied to a transmitting medium using the spectral transmission factor instead of the spectral

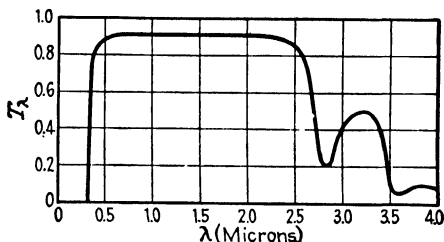

FIG. 86.—Spectral transmission factor of Pyrex glass, 2 mm. thick

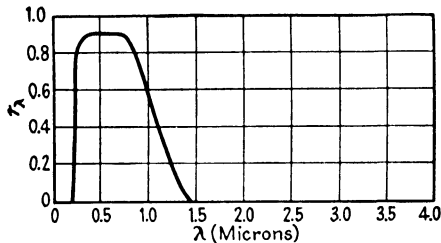

FIG. 87.—Spectral transmission of pure water, 21 mm. thick.

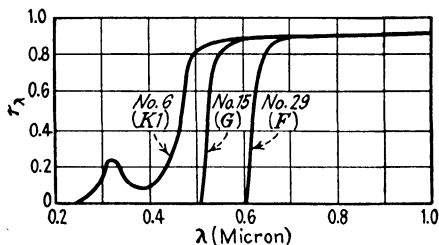

FIG. 88.—Spectral transmission of several Wratten filters for photographic use. reflection factor. Such a procedure is shown in Fig. 89 where the J'_λ is the spectral emission due to transmitted radiant-power density.

Or by interchanging the evaluation of τ_λ and ν_λ the same end result, luminosity, can be obtained as is illustrated in Fig. 90.

In a similar manner to that for reflection factor, the *transmission factor* may be defined as

$$\tau = \frac{L'}{E} \tag{93}$$

where τ = transmission factor corresponding to the spectro-radiometric distribution from which the illumination is derived.

L' = luminosity due to transmission.

E = illumination.

For the same reasons as were pointed out concerning reflection factor, the transmission factor depends not only upon the transmitting medium but also upon the spectroradiometric distribution of the irradiation from which the illumination is derived.

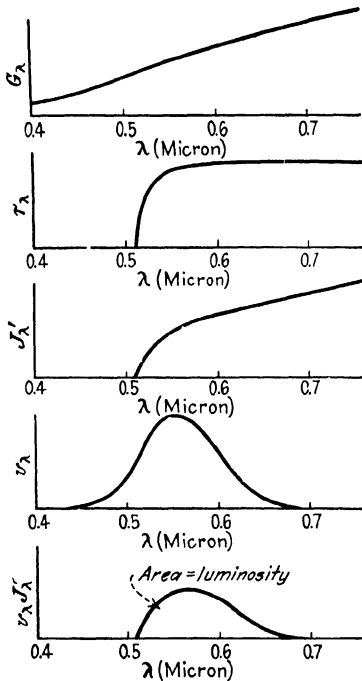

FIG. 89.—Process of evaluating luminosity through the emission due to transmission.

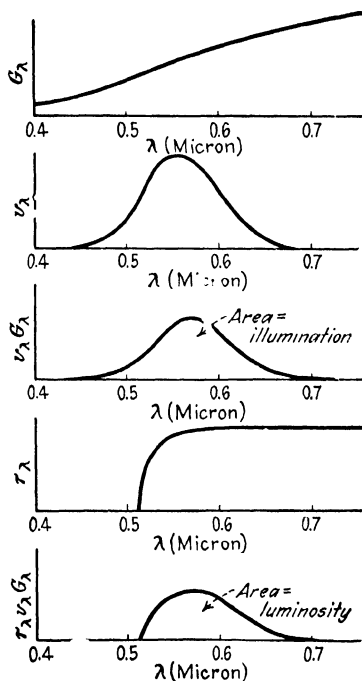

FIG. 90.—Process of evaluating luminosity of a transmitting medium through a previous evaluation of illumination from the irradiation.

Problems

1.8. Plot on polar coordinates the brightness of each of the four elements of area shown in Figs. 72 to 75, assuming that the actual area of the element is 1 sq. in. and that each unit of radial distance on the diagram is 10 candles.

2.8. The surface for which the spectral-reflection-factor variation is illustrated in Fig. 77 is irradiated by a "white" fluorescent-lamp source to

such a degree that the illumination is 20 lumens per square foot. What is the luminosity of the surface? What is the reflection factor for this irradiation?

3.8. The same surface as in Prob. 2.8 is irradiated by a green fluorescent-lamp source to such a degree that the illumination is also 20 lumens per square foot. What is the luminosity of the surface? What is the reflection factor for this irradiation?

4.8. What percentage of the irradiation for the "white" fluorescent lamp is of such wave lengths as evoke each of the sensations of the various hues as defined in Table 4? What percentage of illumination is of such wave lengths as to evoke these same hue sensations? What percentage of the luminosity of problem 2.8 is of such wave lengths as to evoke these same hue sensations? Compare these three sets of results.

5.8. Determine the average luminosity of the element of surface for which the intensity-distribution curve is shown in Fig. 84 if the maximum intensity is 10 candles and the area of the element is 1 sq. in.

REFERENCES

- W. W. Coblentz, Radiometric Investigations of Water of Crystallization, *Nat. Bur. Standards, Sci. Papers*, 168, 1911.
- P. Moon, "The Scientific Basis of Illuminating Engineering," McGraw-Hill Book Company, Inc., New York, 1936.
- General Electric Recording Photoelectric Spectrophotometer, *Gen. Elec. Bull.* GES-1375, February, 1938.
- "Glass Color Filters," Corning Glass Works Catalog C-206, 1940.
- "Wratten Light Filters," 16th ed. revised, Eastman Kodak Company, 1940.

CHAPTER 9

ELECTRICAL LIGHT SOURCES AND THEIR OPERATING CHARACTERISTICS

<i>Symbol</i>	<i>Term</i>	<i>Definition</i>
ℒ	Life of lamp	The average laboratory life of a large number of similar lamps when burned under carefully controlled conditions. For design purposes the life may be designated as that period required to evaporate a certain percentage of the original filament.
	Cold-cathode lamps	Lamps designed in such a manner that the cathode or cathodes are operated at approximately the same temperature as the temperature of the arc stream of the lamp.
	Hot-cathode lamps	Lamps designed in such a manner that the cathode or cathodes are operated at a temperature very much higher than the temperature of the arc stream of the lamp.

48. General.—The first commercial electric-light sources were the open-arc discharge lights of about 1878. Soon after, incandescent lamps were introduced, principally in interiors at first but later as a replacement source for the early arc lights of street lighting. Only in recent years has there been any revolutionary change in the types of lighting sources commercially available. The gaseous-discharge sources such as mercury-vapor and sodium-vapor lamps have become quite popular in recent years for certain applications. It is of interest that these gaseous-discharge sources have been applied quite liberally as replacement sources for street and highway lighting. Still more recently the fluorescent lamp, which is fundamentally dependent upon the gaseous-discharge action of its arc, has become commercially practical and is being used as a replacement source for many interior incandescent-lighting systems.

Thus we see that in electric-light sources nothing is static and permanent in nature. First luminescent sources were developed and applied; then incandescent sources held the stage; and now

it seems that the cycle is again swinging to the luminescent type of source.

However, incandescent lamps are being and probably will continue to be applied in many new installations where conditions may be more favorable to their application. This chapter will consider all of the present principal types of light sources and their operating characteristics.

49. History of the Incandescent Lamp.—The first incandescent lamp is generally attributed to Thomas Edison, who in 1879 produced a lamp using a filament of carbonized sewing thread. Other earlier lamps utilized carbonized bamboo and paper. Treating the filament with a hydrocarbon, thus forming a coating of graphite on its surface, was the first notable advance in producing a more uniform filament. Later a filament was produced by squirting cellulose through a die, then drying and carbonizing it.

Thus far all the filaments that had been used consisted of some form of a carbonized material. Such filaments possessed negative temperature coefficients of resistivity. In 1905 a process of heating the treated carbonized material to a high temperature was developed. In the process the temperature coefficient of resistivity was changed to a positive value, and the filament was said to be "metalized" because of this change. The lamp was called the *GEM* (General Electric Metallized) lamp.

True metal-filament lamps were introduced the next year through osmium lamps and tantalum lamps. Tungsten lamps, however, soon replaced both of these types in 1907. At that time no process of drawing tungsten was known, since the tungsten was very brittle. The first tungsten lamps used filaments made by mixing tungsten powder with a binder to form a paste and then squirting it through a die. The thread thus formed was then treated and mounted in the bulb. The lamp was very fragile. In 1911 Coolidge discovered a method of making tungsten ductile so that it could be drawn directly.

Until 1913 all lamps had been evacuated-bulb lamps. Such lamps are today known as type B lamps. Langmuir investigated the possibility of using an inert gas in the bulb to reduce the large evaporation resulting from the very low pressure at the surface of the hot filament. Edison had attempted the same process; but with the low temperature of his filaments the

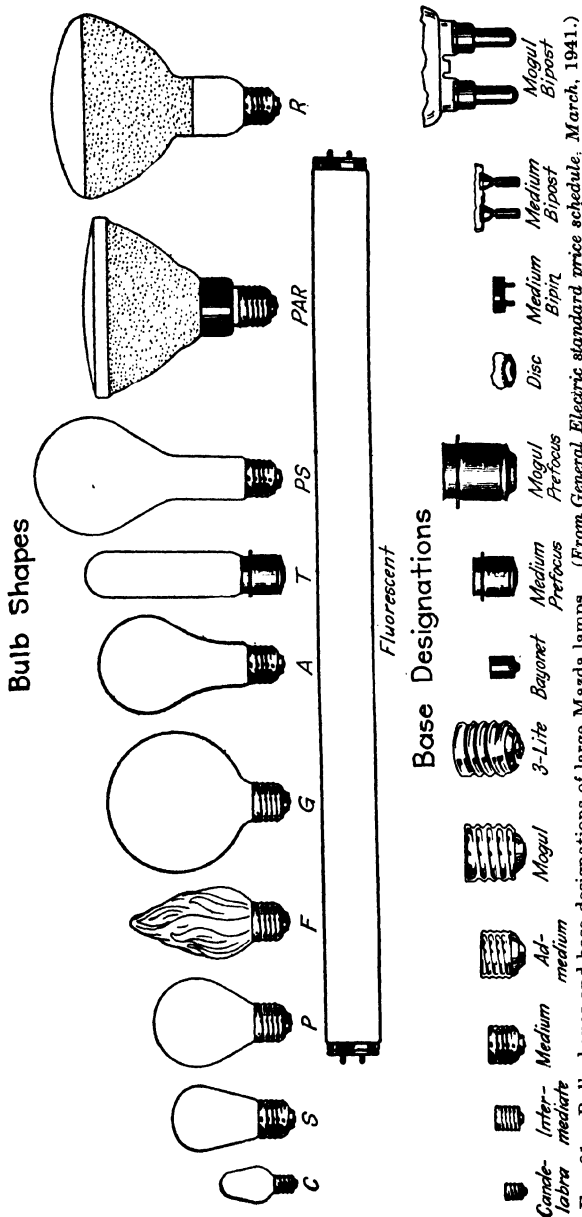

FIG. 91.—Bulb shapes and base designations of large Mazda lamps. (From General Electric standard price schedule, March, 1941.)

increased convection losses due to the gas as a carrier overshadowed the effect of reduced evaporation to such an extent that he obtained practically no light. With the higher temperature of filament operation possible in 1913, the gas-filled lamp was found economical in large lamp sizes. In recent years the minimum lamp size at which the effect of reduced evaporation predominates over the effect of increased convection losses has been gradually reduced because of the increased temperature of filament operation. However even today no standard lamp of less than 40-watt rating is gas filled. The gas-filled lamps are designed as type C lamps.

Recent developments in incandescent lamps have been the coiled and double-coiled filament. Both of these developments have been made in an effort to operate the filament at a higher temperature at the same power input. The more concentrated filament accomplishes this effect by reducing the convection losses—thus allowing more power to be radiated. Also the spectral distribution of an incandescent body operating in the range 2300 to 3500°K. is such that more power is radiated in the visible region of the spectrum with filaments operating at the higher temperatures. The result of these two effects is evident in comparing the initial lumens per watt of various size lamps of the same voltage rating of Table 7.

50. Incandescent-lamp Ratings.—Lumen and life ratings and other significant data on various types of incandescent lamps are given in Table 7. These are taken from the General Electric Company schedule of March, 1941. The letter in the bulb designation indicates the shape of the bulb, and the figure indicates the approximate diameter of the bulb in eighths of an inch. The various bulb shapes and base designations are shown in Fig. 91. The over-all length is measured from the top of the bulb to the bottom of the base. The light center length is measured from the center of the filament to the bottom of the screw base, to the top of base pins or fins of bayonet or prefocused bases, to the shoulder of the post of mogul bipost bases or to the bottom of bulb (base end) for medium bipost bases.

The finish of the bulb is clear, inside frosted, daylight, etc. The daylight bulbs are those having a light blue glass to filter some of the red, orange, yellow rays and thus produce a light that more nearly approximates daylight.

TABLE 7.—LARGE MAZDA LAMPS AND TYPE D LAMPS

Watts	Bulb	Base	Finish, color, or other description	List price	Std. pkg. qty.	Fil. const. Mazda C lamp	Mazda Rated age life, hr. ^a	Max. over-all length, in.	Average light center length, in.	Ap-prox. initial lu-mens	Rated initial lu-mens per watt	Lu-mens per watt at 70% of rated life	Position of burning	
Mazda Lamps for 110-, 115-, and 120-volt Circuits														
6	S-6	Cand.	Clear.....	\$0.15	120	C-7A	B	1500	1½	39	6.6	Any
6	S-14	Med.	Clear.....	0.15	120	C-9	B	1500	3½	2½	38	6.4	Any
			Inside frosted.....	0.15	120	C-9	B	1500	3½	2½	37	6.3	Any
			Ins. col. red.....	0.20	120	C-9	B	1500	3½	Any
			Ins. col. blue.....	0.20	120	C-9	B	1500	3½	Any
			Ins. col. green.....	0.20	120	C-9	B	1500	3½	Any
7	C-7 ^b	Cand.	Ins. col. yellow.....	0.20	120	C-9	B	1500	3½	Any
			Ins. col. amber-orange.....	0.20	120	C-9	B	1500	3½	Any
			Ins. col. old rose.....	0.20	120	C-9	B	1500	3½	Any
			Clear.....	0.10	120	C-7A	B	2000	2½	50	7.1
7½	G-11 ^c	Med.	White.....	0.10	120	C-7A	B	2000	2½	Any
			Outside white.....	0.10	120	C-7A	B	1400	2¼	Any
10	S-11	Inter.	Outside red.....	0.10	120	C-7A	B	1400	2¼	Any
			Clear.....	0.15	120	C-7A	B	1500	2½	1½	79	7.9	Any
			Ins. col. red.....	0.20	120	C-7A	B	1500	2½	1½	Any
			Ins. col. blue.....	0.20	120	C-7A	B	1500	2½	1½	Any
			Ins. col. green.....	0.20	120	C-7A	B	1500	2½	1½	Any	

LIGHT SOURCES AND OPERATING CHARACTERISTICS 117

10 S-14	Med.	Ins. col. yellow.....	0.20	120	C-7A	B	1500	2½ ¹⁶	1½	Any
		Ins. col. amber-orange.....	0.20	120	C-7A	B	1500	2½ ¹⁶	1½	Any
		Ins. col. flametint.....	0.20	120	C-7A	B	1500	2½ ¹⁶	1½	Any
		Ins. col. white.....	0.20	120	C-7A	B	1500	2½ ¹⁶	1½	Any
15 A-15	Med.	Clear.....	0.13	120	C-9	B	1500	3½	2½	78	7.8 ^d	7.3 ^d	Any
		Inside frosted.....	0.13	120	C-9	B	1500	3½	2½	77	7.7 ^d	7.2 ^d	Any
		Ins. col. red.....	0.18	120	C-9	B	1500	3½	Any
		Ins. col. blue.....	0.18	120	C-9	B	1500	3½	Any
		Ins. col. green.....	0.18	120	C-9	B	1500	3½	Any
		Ins. col. yellow.....	0.18	120	C-9	B	1500	3½	Any
		Ins. col. amber-orange.....	0.18	120	C-9	B	1500	3½	Any
		Ins. col. old rose.....	0.18	120	C-9	B	1500	3½	Any
		Nat. col. amber*.....	0.40	120	C-9	B	1500	3½	Any
		Nat. col. blue/.....	0.40	120	C-9	B	1500	3½	Any
15 F-10 ^e	Cand.	Nat. col. green.....	0.40	120	C-9	B	1500	3½	Any
		Nat. col. ruby ^g	0.50	120	C-9	B	1500	3½	Any
15 A-15	Med.	Inside frosted.....	0.10	120	C-9	B	750	3½	2 ³ / ₈	150	9.9 ^d	8.7 ^d	Any
		Flametint.....	0.20	60	C-7A	B	750	3½ ¹⁶	Any
		White.....	0.20	60	C-7A	B	750	3½ ¹⁶	Any
15 F-10 ^e	Cand.	Ivory.....	0.20	60	C-7A	B	750	3½ ¹⁶	Any
		0.20	60	C-7A	B	750	3½ ¹⁶	Any

* Life under specified test conditions.
^b Nominal watts. 110-125 volts (design volts 118).
^c Outside-coated lamps not recommended for outdoor use.
^d Lumens per watt listed are for 120-volt lamps only. For 115-volt lamps add 0.10 lumens per watt; for 115-volt lamps add 0.05 lumens per watt.
^e Amber regularly furnished in light shade. Dark shade amber (used in photographic work) can be furnished at same price.
^f Blue shade does not include daylight blue or photographic blue.
^g Ruby regularly furnished in light shade. Dark shade ruby (used in photographic work) can be furnished at same price.

TABLE 7.—LARGE MAZDA LAMPS AND TYPE D LAMPS.—(Continued)

Watts	Bulb	Base	Finish, color, or other description	List price	Std. pkg. qty.	Fil. const.	Mazda B or C lamp	Rated age all length, in.	Max. over-all length, in.	Average light center length, in.	Ap. prox. initial lumens	Rated initial lumens per watt	Lu. mens per watt at 70% of rated life	Position of burning	
Mazda Lamps for 110-, 115-, and 120-volt Circuits.—(Continued)															
25	A-19	Med.	Inside frosted.....	\$0.10	120	C-9	B	750	3 1/4	2 1/2	270	10.9	9.2	Any	
			Ins. col. red.....	0.19	120	C-9	B	1000	3 1/2	Any
			Ins. col. blue.....	0.19	120	C-9	B	1000	3 1/2	Any
			Ins. col. green.....	0.19	120	C-9	B	1000	3 1/2	Any
			Ins. col. yellow.....	0.19	120	C-9	B	1000	3 1/2	Any
			Ins. col. amber-orange.....	0.19	120	C-9	B	1000	3 1/2	Any
			Ins. col. flametint.....	0.19	120	C-9	B	1000	3 1/2	Any
			Ins. col. ivory.....	0.19	120	C-9	B	1000	3 1/2	Any
			Ins. col. old rose.....	0.19	120	C-9	B	1000	3 1/2	Any
			Nat. col. amber*.....	0.40	120	C-9	B	1000	3 1/2	Any
			Nat. col. blue/.....	0.40	120	C-9	B	1000	3 1/2	Any
			Nat. col. green.....	0.40	120	C-9	B	1000	3 1/2	Any
Nat. col. ruby*.....	0.50	120	C-9	B	1000	3 1/2	Any			
25	F-15	Med.	Flametint.....	0.15	120	C-9	B	750	4 1/2	Any	
			White.....	0.15	120	C-9	B	750	4 1/2	Any	
			Ivory.....	0.15	120	C-9	B	750	4 1/2	Any	
25	G-18 1/2	Med.	Flametint.....	0.30	120	C-9	B	750	3 3/4	Any	
			White.....	0.30	120	C-9	B	750	3 3/4	Any	
			Ivory.....	0.30	120	C-9	B	750	3 3/4	Any	

25 G-25 ^c	Med.	Flamint. White Ivory	0.35 0.35 0.35	60 60 60	C-7A C-7A C-7A	B B B	750 750 750	4 $\frac{1}{2}$ % 4 $\frac{1}{16}$ % 4 $\frac{1}{16}$ %	Any Any Any
25 T-6 $\frac{1}{2}$	Inter.	Clear	0.35	60	C-8	B	1000	5 $\frac{1}{2}$ %	245	9.9	Any
25 T-10	Med.	Clear Reflector ^a	0.25 0.50	60 60	C-8 CC-8	B C	1000 1000	5 $\frac{5}{8}$ % 5 $\frac{5}{8}$ %	255 230	10.2 ^d	Any Any
30 T-8 Lumline	Disk	Clear Inside frosted Ins. col. white Ins. col. straw	0.85 0.85 0.95 0.95	24 24 24 24	C-8 C-8 C-8 C-8	B B B B	1500 1500 1500 1500	17 $\frac{3}{4}$ % ⁱ 17 $\frac{3}{4}$ % 17 $\frac{3}{4}$ % 17 $\frac{3}{4}$ %	245 240	8.1 8.0	Any Any Any Any
40 A-19	Med.	Inside frosted	0.13	120	C-9	C	1000	4 $\frac{1}{4}$ %	2 $\frac{1}{8}$ %	465	11.6 ^j	Any ^k
40 A-21	Med.	Nat. col. amber ^e Nat. col. blue/ Nat. col. green Nat. col. ruby ^g	0.40 0.40 0.40 0.50	120 120 120 120	C-7A C-7A C-7A C-7A	B B B B	1000 1000 1000 1000	4 $\frac{1}{16}$ % 4 $\frac{1}{16}$ % 4 $\frac{1}{16}$ % 4 $\frac{1}{16}$ %	Any Any Any Any

^a Life under specified test conditions.
^c Outside-coated lamps not recommended for outdoor use.
^d Lumens per watt listed are for 120-volt lamps only. For 110-volt lamps add 0.10 lumens per watt; for 115-volt lamps add 0.05 lumens per watt.
^e Amber regularly furnished in light shade. Dark shade amber (used in photographic work) can be furnished at same price.
^f Blue shade does not include day, light blue or photographic blue.
^g Ruby regularly furnished in light shade. Dark shade ruby (used in photographic work) can be furnished at same price.
^h Medium screw base with spring contact. M.O.L. is exclusive of spring contact.
ⁱ Average over-all length.
^j Lumens per watt listed are for 120-volt lamps only. For 110-volt lamps add 0.30 lumens per watt; for 115-volt lamps add 0.15 lumens per watt.
^k Will operate in any position, but lumen maintenance is best when burned vertically base up, and lumens per watt values at 70 per cent of rated life, when shown, apply to this burning position only.

TABLE 7.—LARGE MAZDA LAMPS AND TYPE D LAMPS.—(Continued)

Watts	Bulb	Base	Finish, color, or other description	List price	Std. pkg. qty.	Fil. const.	Mazda B or Mazda C lamp	Rated average life, hr.*	Max. over-all length, in.	Average light center length, in.	Ap-prox. initial lumens	Rated initial lumens per watt	Lumens per watt of rated life	Position of burning
Mazda Lamps for 110-, 115-, and 120-volt Circuits.—(Continued)														
40	G-25*	Med.	Flametint.....	\$0.35	60	C-7A	B	750	4 $\frac{1}{16}$	Any
			White.....	0.35	60	C-7A	B	750	4 $\frac{1}{16}$	Any
			Ivory.....	0.35	60	C-7A	B	750	4 $\frac{1}{16}$	Any
40	T-8	Med.	Clear.....	0.85	24	C-8	B	1000	1 $\frac{1}{2}$	410	10.2	8.5	Any
40	T-8	Disk	Clear.....	0.75	24	C-8	B	1500	1 $\frac{1}{4}$	345	8.6	Any
	Lumiline		Inside frosted.....	0.75	24	C-8	B	1500	1 $\frac{1}{4}$	340	8.5	Any
			Ins. col. white.....	0.85	24	C-8	B	1500	1 $\frac{1}{4}$	Any
			Ins. col. straw.....	0.85	24	C-8	B	1500	1 $\frac{1}{4}$	Any
			Ins. col. orange.....	0.85	24	C-8	B	1500	1 $\frac{1}{4}$	Any
			Ins. col. moonlight blue.....	0.85	24	C-8	B	1500	1 $\frac{1}{4}$	Any
			Ins. col. surprise pink.....	0.85	24	C-8	B	1500	1 $\frac{1}{4}$	Any
			Ins. col. emerald.....	0.85	24	C-8	B	1500	1 $\frac{1}{4}$	Any
50	A-19	Med.	Inside frosted.....	0.13	120	CC-6	C	1000	4 $\frac{1}{16}$	3 $\frac{1}{2}$	660	13.2 ^d	12.5 ^j	Any*
			I. F. rough service.....	0.25	120	C-22	B	1000	3 $\frac{1}{16}$	2 $\frac{1}{2}$	455	9.1 ^d	7.5 ^d	Any
50	P-19	Med.	Clear vibration.....	0.20	120	C-9	B	1000	3 $\frac{1}{16}$	2 $\frac{1}{2}$	545	10.9 ^d	8.4 ^d	Any ⁱ
50	PS-25 100 150	Three contact mogul	I. F. three-lite.....	0.45	60	2C-9	C	1000	6 $\frac{3}{16}$	5	575 1500 2075	11.5 15.1 13.9	Any

60 A-19	Med.	Inside frosted..... Daylight inside frosted..... I. F. silvered bowl.....	0.13 0.25 0.23	120 120 120	CC-6 CC-6 CC-6	C C C	1000 1000 1000	4 $\frac{1}{16}$ 4 $\frac{1}{16}$ 4 $\frac{1}{16}$	3 $\frac{1}{8}$ 3 $\frac{1}{8}$ 3 $\frac{1}{8}$	835 540	13.9 ^f	13.0 ⁱ	Any* Any* Any*
60 A-21	Med.	Nat. col. amber**..... Nat. col. blue/™..... Nat. col. green™..... Nat. col. ruby®.....	0.45 0.45 0.45 0.55	120 120 120 120	C-9 C-9 C-9 C-9	C C C C	1000 1000 1000 1000	4 $\frac{1}{16}$ 4 $\frac{1}{16}$ 4 $\frac{1}{16}$ 4 $\frac{1}{16}$	Any Any Any Any
60 T-8 Lumiline	Disk	Clear traffic signal..... Clear..... Inside frosted..... Ins. col. white..... Ins. col. straw..... Ins. col. orange..... Ins. col. moonlight blue..... Ins. col. surprise pink..... Ins. col. emerald.....	0.25 0.85 0.85 0.95 0.95 0.95 0.95 0.95 0.95	120 24 24 24 24 24 24 24 24	C-9 C-8 C-8 C-8 C-8 C-8 C-8 C-8 C-8	C B B B B B B B B	2000 1500 1500 1500 1500 1500 1500 1500 1500	4 $\frac{1}{16}$ 17 $\frac{3}{4}$ [†] 17 $\frac{3}{4}$ [†] 17 $\frac{3}{4}$ [†] 17 $\frac{3}{4}$ [†] 17 $\frac{3}{4}$ [†] 17 $\frac{3}{4}$ [†] 17 $\frac{3}{4}$ [†] 17 $\frac{3}{4}$ [†]	2 $\frac{1}{16}$	655 530 520	10.9 8.8 8.7	{ Base down or horiz.

* Life under specified test conditions.
 † Outside-coated lamps not recommended for outdoor use.
 ‡ Lumens per watt listed are for 120-volt lamps only. For 110-volt lamps add 0.03 lumens per watt; for 115-volt lamps add 0.05 lumens per watt.
 § Amber regularly furnished in light shade. Dark shade amber (used in photographic work) can be furnished at same price.
 ¶ Blue shade does not include daylight blue or photographic blue.
 †† Ruby regularly furnished in light shade. Dark shade ruby (used in photographic work) can be furnished at same price.
 ‡‡ Average over-all length.
 ††† Lumens per watt listed are for 120-volt lamps only. For 110-volt lamps add 0.30 lumens per watt; for 115-volt lamps add 0.15 lumens per watt.
 †††† Will operate in any position, but lumen maintenance is best when burned vertically base up, and lumens per watt values at 70 per cent of rated life, when shown, apply to this burning position only.
 ††††† Not recommended for horizontal burning.
 †††††† This lamp not to be burned in enclosing globe.

TABLE 7.—LARGE MAZDA LAMPS AND TYPE D LAMPS.—(Continued)

Watts	Bulb	Base	Finish, color, or other description	List price	Std. pkg. qty.	Fill. const.	Mazda B or C lamp	Rated average life, hr. ^a	Max. over-all length, in.	Average light center length, in.	Approx. initial lumens	Rated initial lumens per watt	Lumens per watt at 70% of rated life	Position of burning			
Mazda Lamps for 110-, 115-, and 120-volt Circuits.—(Continued)																	
75	A-21	Med.	Inside frosted.....	\$0.15	120	C-9	C	750	5½ ¹⁶	3¾	1100	14.9 ⁱ	13.5 ^j	Any ^k			
100	A-23	Med.	Inside frosted.....	0.15	120	CC-6	C	750	6½ ¹⁶	4¾	1650	16.3 ⁱ	15.2 ^j	Any ^k			
			Daylight inside frosted.....	0.25	120	CC-6	C	750	6½ ¹⁶	4¾	1050	Any ^k		
			I. F. silvered bowl.....	0.25	120	CC-6	C	750	6½ ¹⁶	4¾	Any ^k		
			I. F. rough service.....	0.35	120	C-17	C	1000	6½ ¹⁶	4¾	1200	11.9 ⁱ	10.2 ^j	Any		
100 200 300	G-30	Three contact mogul	I. F. indirect three-lite.....	0.60	24	2C-7A	C	1000	6¾	3¾	{ 1400 3500 4900 }	{ 13.8 17.4 16.2 }	Base down			
			150	A-25	Med.	Inside frosted.....	0.20	60	C-8	C	750	6½ ¹⁶	5¼	2600	17.4 ⁱ	15.6 ^j	Any ^k
						Clear.....	0.20	60	C-9	C	750	6½ ¹⁶	5¼	2600	17.4 ⁱ
200	PS-30	Med.	Inside white bowl.....	0.25	60	C-9	C	750	6½ ¹⁶	5¼	Any ^k		
			Daylight clear.....	0.40	60	C-9	C	750	6½ ¹⁶	5¼	1700	Any ^k		
			Daylight inside frosted.....	0.45	60	C-9	C	750	6½ ¹⁶	5¼	1700	Any ^k		
200	PS-30	Med.	I. F. silvered bowl ^a	0.45	60	C-9	C	1000	6½ ¹⁶	5¼	Any ^k		
			Clear.....	0.27	60	C-9	C	750	8½ ¹⁶	6	3700	18.5 ⁱ	16.3 ^j	Any ^k		
			Inside frosted.....	0.27	60	C-9	C	750	8½ ¹⁶	6	3700	18.5 ⁱ	Any ^k		
200	PS-30	Med.	Inside white bowl.....	0.32	60	C-9	C	750	8½ ¹⁶	6	Any ^k		

300 PS-35	Daylight clear.....	0.70	60	C-9	C	1000	8½e	6	2400	Any [†]
	Daylight inside frosted.....	0.75	60	C-9	C	1000	8½e	6	2400	Any [†]
	I. F. silvered bowl ^a	0.62	60	C-9	C	1000	8½e	6	Base up
Med.	Clear (750 hr.).....	0.45	24	C-9	C	750	8¾	6	5950	19.8 [†]	Any [†]
	I. F. (750 hr.).....	0.50	24	C-9	C	750	8¾	6	5950	19.8 [†]	Any [†]
	I. W. B. (750 hr.).....	0.50	24	C-9	C	750	8¾	6	Any [†]
Mog.	Clear (1000 hr.).....	0.65	24	C-9	C	1000	9¾	7	5700	19.0 [†]	Any [†]
	I. F. (1000 hr.).....	0.70	24	C-9	C	1000	9¾	7	5700	19.0 [†]	Any [†]
	I. W. B. (1000 hr.).....	0.70	24	C-9	C	1000	9¾	7	Any [†]
500 PS-40	Daylight clear.....	1.10	24	C-9	C	1000	9¾	7	3700	Any [†]
	Daylight inside frosted.....	1.20	24	C-9	C	1000	9¾	7	3700	Any [†]
	I. F. silvered bowl ^a	1.10	24	C-9	C	1000	9¾	7	Base up
Mog.	Clear.....	1.10	12	C-7A	C	1000	9¾	7	10,000	20.0 [†]	Any [†]
	Inside frosted.....	1.20	12	C-7A	C	1000	9¾	7	10,000	20.0 [†]	Any [†]
	Inside white bowl.....	1.20	12	C-7A	C	1000	9¾	7	Any [†]
750 T-24	Daylight clear.....	1.85	12	C-7A	C	1000	9¾	7	6500	Any [†]
	Daylight inside frosted.....	1.95	12	C-7A	C	1000	9¾	7	6500	Any [†]
	I. F. silvered bowl ^a	1.70	12	C-7A	C	1000	9¾	7	Base up
M.d. bip.	Inside frosted.....	3.50	6	C-13	C	1000	9¾	5½	14,000	18.8	Base up

^a Life under specified test conditions.
[†] Lumens per watt listed are for 120-volt lamps only. For 110-volt lamps add 0.30 lumens per watt; for 115-volt lamps add 0.15 lumens per watt.
[‡] Will operate in any position, but lumen maintenance is best when burned vertically base up, and lumens per watt values at 70 per cent of rated life, when shown, apply to this burning position only.
[§] Silvered bowl lamps should be used only in porcelain sockets and in fixtures so designed that the temperatures of the lamp and fixture do not exceed limits for satisfactory operation.
[¶] Recommended burning position any within 60 deg. of vertically base up or base down, but lumen maintenance is best when burned vertically base up, and lumens per watt values at 70 per cent of rated life, when shown, apply to this burning position only.

TABLE 7.—LARGE MAZDA LAMPS AND TYPE D LAMPS.—(Continued)

Watts	Bulb	Base	Finish, color, or other description	List price	Std. pkg. qty.	Fil. const.	Mazda B or Mazda C lamp	Max. over-all length, in.	Average light center length, in.	Approx. initial lumens	Rated initial lumens per watt	Lumens per watt at 70% of rated life	Position of burning	
Mazda Lamps for 110-, 115-, and 120-volt Circuits.—(Continued)														
750	PS-52	Mog.	Clear	\$3.25	6	C-7A	C	1000	9½	15,000	19.8	17.7	Any*	
			Inside frosted	3.45	6	C-7A	C	1000	13½	15,000	19.8	Any*	
			Inside white bowl	3.45	6	C-7A	C	1000	13½	Any*
			I. F. silvered bowl	4.75	6	C-7A	C	1000	13½	Base up
1000	T-24	Md. bip.	Inside frosted	3.75	6	C-13	C	1000	9½	19,500	19.5	17.9	Base up	
			Clear	3.50	6	C-7A	C	1000	13½	21,500	21.3	17.5	Any*	
1000	PS-52	Mog.	Inside frosted	3.70	6	C-7A	C	1000	13½	21,500	21.3	Any*	
			Inside white bowl	3.70	6	C-7A	C	1000	13½	Any*	
			I. F. silvered bowl	5.00	6	C-7A	C	1000	13½	Base up
			Clear	5.25	6	C-7A	C	1000	13½	33,500	22.2	15.7	Any*	
1500	PS-52	Mog.	Inside frosted	5.55	6	C-7A	C	1000	13½	33,500	22.2	Any*	
			Inside white bowl	5.55	0	C-7A	C	1000	13½	Any*	

Type D Lamps—110, 115, and 120 Volts Only

30 } 70 } 100 }	G-19	Med.	Inside frosted.....	0.10	120	C-9	Vac.	500	3 $\frac{1}{2}$ %	340	11.3 ^d	Any	
			Out. col. red ^e	0.10	120	C-9	Vac.	500	3 $\frac{1}{2}$ %	Any
			Out. col. blue ^e	0.10	120	C-9	Vac.	500	3 $\frac{1}{2}$ %
30 } 70 } 100 }	A-21	Three } contact } med. }	Out. col. green ^e	0.10	120	C-9	Vac.	500	3 $\frac{1}{2}$ %	Any	
			Out. col. amber-orange ^e	0.10	120	C-9	Vac.	500	3 $\frac{1}{2}$ %	Any
			Out. col. rose ^e	0.10	120	C-9	Vac.	500	3 $\frac{1}{2}$ %	Any
30 } 70 } 100 }	A-21	Three } contact } med. }	White.....	0.10	120	C-9	Vac.	500	3 $\frac{1}{2}$ %	Any	
			Out. col. ivory ^e	0.10	120	C-9	Vac.	500	3 $\frac{1}{2}$ %	Any
			Out. col. flamentint ^e	0.10	120	C-9	Vac.	500	3 $\frac{1}{2}$ %	Any
50 } 100 } 150 }	A-25	Three } contact } med. }	I. F. three-lite.....	0.25	120	2 C-9	Gas F.	500	5 $\frac{1}{2}$ %	3 $\frac{1}{2}$ %	315 } 1050 } 1365 }	10.5 } 15.2 } 13.8 }	Base down	
			I. F. three-lite.....	0.30	60	2 C-9	Gas F.	500	5 $\frac{1}{2}$ %	3 $\frac{1}{2}$ %	625 } 1600 } 2225 }	12.5 } 15.8 } 14.7 }	Base down	
			Inside frosted.....	0.10	120	C-9	Gas F.	500	4 $\frac{1}{2}$ %	Any
60	A-19	Med.	White.....	0.10	120	C-9	Gas F.	500	4 $\frac{1}{2}$ %	835	13.9 ^f	Any	
				0.10	120	C-9	Gas F.	500	4 $\frac{1}{2}$ %	835	Any

^a Life under specified test conditions.

^e Outside-coated lamps not recommended for outdoor use.

^d Lumens per watt listed are for 120-volt lamps only. For 110-volt lamps add 0.10 lumens per watt; for 115-volt lamps add 0.05 lumens per watt.

ⁱ Lumens per watt listed are for 120-volt lamps only. For 110-volt lamps add 0.03 lumens per watt; for 115-volt lamps add 0.15 lumens per watt.

^e Recommended burning position any within 60 deg. of vertically base up or base down, but lumen maintenance is best when burned vertically base up, and lumens per watt values at 70 per cent of rated life, when shown, apply to this burning position only.

^f The light center length of this lamp is the distance from center of light source to plane of bottom of bulb (exclusive of tip).

TABLE 7.—LARGE MAZDA LAMPS AND TYPE D LAMPS.—(Continued)

Watts	Bulb	Base	Volts	Finish, color, or other description	List price	Std. pkg. qty.	Fil. const.	Mazda B or Mazda C lamp	Rated average life, hr.	Max. over-all length, in.	Average light center length, in.	Ap-prox. initial lumens	Rated initial lumens per watt	Lumens per watt at 70% of rated life	Position of burning
Mazda Lamps for High-voltage Service—220, 230, 240, 250 and 260 Volts															
25	A-19	Med.	230	Inside frosted.....	0.22	120	C-17	B	1000	3 1/4	2 1/2	215	8.74	7.84	Any
50	A-21	Med.	230	Inside frosted.....	0.22	120	C-17	B	1000	4 1/4	2 7/8	480	9.64	8.34	Any
			275	Inside frosted mine.....	0.33	120	C-17	B	1000	4 1/4	2 7/8	460	9.2	Any
			300	Inside frosted mine.....	0.33	120	C-17	B	1000	4 1/4	2 7/8	460	9.2	Any
100	A-23	Med.	230	Inside frosted.....	0.31	120	C-7A	C	1000	6 1/4	4 3/8	1250	12.44	11.64	Any*
200	FS-30	Med.	230	Clear.....	0.60	60	C-9	C	1000	8 1/4	6	2950	14.84	13.74	Any*
			230	Inside frosted.....	0.65	60	C-9	C	1000	8 1/4	6	2950	14.84	Any*
300	FS-35	Mog.	230	Clear.....	1.00	24	C-7A	C	1000	9 3/4	7	4850	16.14	14.44	Any*
			230	Inside frosted.....	1.10	24	C-7A	C	1000	9 3/4	7	4850	16.14	Any*
500	FS-40	Mog.	230	Clear.....	1.80	12	C-7A	C	1000	9 3/4	7	8750	17.54	15.44	Any*
			230	Inside frosted.....	1.90	12	C-7A	C	1000	9 3/4	7	8750	17.54	Any*
750	FS-52	Mog.	230	Clear.....	4.25	6	C-7A	C	1000	13 1/4	9 1/2	13,500	18.24	15.94	Any*
			230	Inside frosted.....	4.50	6	C-7A	C	1000	13 1/4	9 1/2	13,500	18.24	Any*
1000	FS-52	Mog.	230	Clear.....	4.75	6	C-7A	C	1000	13 1/4	9 1/2	19,500	19.44	16.44	Any*
			230	Inside frosted.....	5.00	6	C-7A	C	1000	13 1/4	9 1/2	19,500	19.44	Any*
Mazda Lamps for Train and Locomotive Service															
15	A-17	Med.	30	Inside frosted.....	\$0.20	120	C-9	C	1000	3 3/4	2 3/8	175	11.8	11.2	Any*
			32	Inside frosted.....	0.20	120	C-9	C	1000	3 3/4	2 3/8	190	11.8	11.2	Any*
			60	Inside frosted.....	0.20	120	C-9	B	1000	3 3/4	2 3/8	150	10.0	Any
			64	Inside frosted.....	0.20	120	C-9	B	1000	3 3/4	2 3/8	160	10.0	Any

15 S-14	Med.	34	Clear cab.	0.20	120	C-9	B	1000	3½	2½	140	9.4	Any
25 A-19	Med.	30	Inside frosted.....	0.20	120	C-9	C	1000	3½	2½	340	13.7	13.0	Any*
		32	Inside frosted.....	0.20	120	C-9	C	1000	3½	2½	365	11.4	13.0	Any*
		60	Inside frosted.....	0.20	120	C-9	C	1000	3½	2½	285	11.7	Any*
		64	Inside frosted.....	0.20	120	C-9	C	1000	3½	2½	305	11.4	Any*
50 A-21	Med.	30	Inside frosted.....	0.20	120	C-9	C	1000	4½	3%	820	16.4	15.4	Any*
		32	Inside frosted.....	0.20	120	C-9	C	1000	4½	3%	875	16.4	15.4	Any*
		60	Inside frosted.....	0.20	120	C-9	C	1000	4½	3%	685	13.7	Any*
		64	Inside frosted.....	0.20	120	C-9	C	1000	4½	3%	730	13.7	Any*
100 A-23	Med.	30	Inside frosted.....	0.33	120	C-9	C	1000	6½	4%	1800	17.8	16.5	Any*
		32	Inside frosted.....	0.33	120	C-9	C	1000	6½	4%	1900	17.8	16.5	Any*
		60	Inside frosted.....	0.33	120	C-9	C	1000	6½	4%	1600	16.2	Any*
		64	Inside frosted.....	0.33	120	C-9	C	1000	6½	4%	1750	16.2	Any*
100 P-25	Med.	32	Clear headlight.....	0.90	60	C-5	C	530	4¾	3	1550	15.7	*
250 P-25	Med.	32	Clear headlight.....	1.40	60	C-5A	C	500	4¾	3	4500	18.0	*

Mazda Lamps for Country-home Service—28-32 Volts

15 A-17	Med.	28-32	Inside frosted.....	0.20	120	C-9	C	1000	3%	2%	175	11.8	Any*
25 A-19	Med.	28-32	Inside frosted.....	0.20	120	C-9	C	1000	3½	2½	340	13.7	Any*
50 A-21	Med.	28-32	Inside frosted.....	0.20	120	C-9	C	1000	4½	3%	820	16.4	Any*
100 A-23	Med.	28-32	Inside frosted.....	0.33	120	C-9	C	1000	6½	4%	1800	17.8	Any*

* Will operate in any position, but lumen maintenance is best when burned vertically base up, and lumens per watt values at 70 per cent of rated life, when shown, apply to this burning position only.
 * Recommended burning position any within 60 deg. of vertically base up or base down, but lumen maintenance is best burned vertically base up, and lumens per watt values at 70 per cent of rated life, when shown, apply to this burning position only.
 † Lumens per watt listed are for 220- and 230-volt lamps only. For 240-, 250-, and 260-volt lamps subtract 0.10 lumens per watt.
 ‡ Lumens per watt listed are for 220- and 230-volt lamps only. For 240-, 250-, and 260-volt lamps subtract 0.30 lumens per watt.
 § Can be burned in any position except within 45 deg. of vertically base up.

TABLE 7.—LARGE MAZDA LAMPS AND TYPE D LAMPS.—(Continued)

Watts	Bulb	Base	Volts	Finish, color, or other description	List price	Std. pkg. qty.	Fil. const.	Mazda B or Mazda C lamp	Rated life, hr.*	Max. over-all length, in.	Average light center length, in.	Approx. initial lumens per watt	Rated initial lumens per watt	Lumens per watt at 70% of rated life	Position of burning
Amperes															
1.0	A-19	Med.	30	Inside frosted.....	\$0.30	120	C-2	C	2000	3 1/16	2 1/2	375	12.5	Any*
1.6	A-21	Med.	30	Inside frosted.....	0.35	120	C-2	C	2000	4 1/16	2 3/4	670	14.0	Any*
Watts															
23	S-17*	Med.	105, 110, 115, 120, 125, 130	Clear (0.214 A.).....	0.20	120	S-1	B	2000	4 5/8	215*	8.7	Any
36	A-19*	Med.		Clear headlight (0.342 A.).....	0.55	120	C-5	B	1000	3 1/16	2 3/16	375*	9.5	Any
36	A-21*	Med.		Inside frosted (0.342 A.).....	0.17	120	C-9	B	2000	4 7/16	2 7/8	375*	9.5	Any*
56	A-21*	Med.		Inside frosted (0.519 A.).....	0.20	120	C-9	B	2000	4 7/16	2 7/8	620*	10.4	Any*
56	P-25*	Med.		Clear headlight (0.519 A.).....	0.80	60	C-5	L	1000	4.4	2 1/4	2 1/4	555*	9.3
94	P-25*	Med.	Clear headlight (0.863 A.).....	1.00	60	C-5	B	1000	4.4	2 1/4	2 1/4	885*	8.9	Any
101	A-23	Med.	Inside frosted.....	0.40	120	C-9	C	1500	6 1/16	4 3/8	4 3/8	1150	11.3	Any*
201	PS-30	Med.	Clear.....	0.75	60	C-9	C	1000	8 1/16	6	6	3100	15.4	Any*
301	PS-35	Mog.	Clear.....	1.30	24	C-7A	C	1000	9 3/8	7	7	5000	16.7	Any*

Mazda Lamps for Street-railway Service

* Life under specified test conditions.
 † Will operate in any position, but lumen maintenance is best when burned vertically base up, and lumens per watt values at 70 per cent of rated life, when shown, apply to this burning position only.
 ‡ The lumens given cover only lamps of 115 volts. The lumens for other lamps are in proportion to the volts.
 § Nominal watts. The actual watts are determined by multiplying the volts by the amperes (the amperes are the same for all voltages).
 ¶ This lamp, if burned horizontally, will not give such good service as when burned in a vertical position.

TABLE 7.—LARGE MAZDA LAMPS AND TYPE D LAMPS.—(Continued)

Mazda Lamps for Projection and Stereopticon Service—100, 105, 110, 115, and 120 Volts

Watts	Bulb	Base	Finish, color, or other description	List price	Std. pkg. qty.	Fil. const.	Mazda B or C lamp	Rated life, hr. ^a	Max. over-all length, in.	Average light center length, in.	Light source dimensions, mm.		Ap-prox. initial lu-mens	Rated initial lu-mens per watt	Position of burning
											Width	Height			
100	T-8	S. C. bay.	Clear.....	\$0 80	24	CC-13	C	50	3 1/8	1 3/8 ^u	5 6 ^r	5.3 ^r	1900	19.2	
200	T-8 ^v	S. C. bay.	Clear.....	1 30	24	2 CC-8	C	25	3 3/8	1 3/8 ^w	6 2 ^r	6.4 ^r	4700	23.5	
200	T-10	Md. pf.	Clear.....	2.00	24	CC-13	C	50	5 3/4	2 3/16 ^r	7.9 ^r	7.9 ^r	4250	21.2	Base down or can be burned within 25 deg. of vertically base down without materially affecting its performance
		Med.	Clear.....	2.00	24	CC-13	C	50	5 1/2	3	7.9 ^r	7.9 ^r	4250	21.2	
300	T-10 ^v	Md. pf.	as	2.70	24	2 CC-8	C	25	5 3/4	2 3/16 ^r	7 0 ^r	9.0 ^r	
500	T-10 ^v	Md. pf.	as	3 50	24	C-13D	C	25	5 3/4	2 3/16 ^r	8.2 ^r	8.3 ^r	
500	T-20	Md. pf.	Clear.....	2.20	6	C-13	C	50	5 3/4	2 3/16 ^r	14 0 ^r	12.0 ^r	13,000	26.5	Base down without materially affecting its performance
		Med.	Clear.....	2.20	6	C-13	C	50	5 1/2	3	14 0 ^r	12 0 ^r	13,000	26.5	
750	T-12 ^v	Md. pf.	as	4 10	24	C-13D	C	25	5 3/4	2 3/16 ^r	9 8 ^r	10 0 ^r	
1000	T-12 ^v	Md. pf.	as	6.00	24	C-13D	C	10	5 3/4	2 3/16 ^r	10.2 ^r	10.2 ^r	
1000	T-20	Mg. pf.	Clear.....	4.75	6	C-13	C	50	9 1/2	3 1/16 ^r	14.9 ^r	14.5 ^r	27,500	27.5	Base down without materially affecting its performance
		Mog.	Clear.....	4.75	6	C-13	C	50	9 1/6	4 3/4 ^r	14.9 ^r	14.5 ^r	27,500	27.5	
		Md. pf.	Clear ^v	4.50	6	C-13D	C	25	5 3/4	2 3/16 ^r	11.7 ^r	11 6 ^r	27,500	27.6	

^a Life under specified test conditions.
^u The light center length of this lamp is the distance from center of light source to top of base pins.
^w Approximate average for 115 volts. Dimensions for other standard voltages will be supplied on request.
^v This lamp should be used only in equipment that provides adequate forced cooling.
^r The light center length of this lamp is the distance from center of light source to top of base fin.
^{as} Clear bulb with opaque end.

TABLE 7.—LARGE MAZDA LAMPS AND TYPE D LAMPS.—(Continued)
Mazda Lamps for Spotlight and Floodlight Service—110, 115, and 120 Volts

Watts	Bulb	Base	Finish, color, or other description	List price	Std. pkg. qty.	Fil. const.	Mazda B or C lamp	Rated age life, hr. ^a	Max. over-all length, in.	Aver- age light center length, in.	Light source dimensions, mm.		Ap- prox. initial lumens	Rated initial lumens per watt	Position of burning
											Width	Height			
100	P-25	Med.	Clear spot.....	\$0.80	60	C-5	C	200	4¾	3	8	7	1350	13.6	
250	G-30	Med.	Clear spot.....	1.15	24	C-5	C	200	5½	3	10	8	4400	17.7	Any position from vertical base down to horizontal ^b
			Clear flood.....	1.15	24	C-5	C	800	5½	3	12	9	3750	15.0	
400	G-30	Med.	Clear spot.....	1.75	24	C-5	C	200	5½	3	11	9	8000	20.0	
500	G-40	Mog.	Clear flood.....	2.10	12	C-5	C	800	7¼	4¼	13	10	8800	17.6	
1000	G-40	Mog.	Clear spot.....	5.00	12	C-5	C	200	7¼	4¼	14	13	22,500	22.5	
			Clear spot.....	5.00	12	C-5	C	200	8	5¼	14	13	22,500	22.5	
			Clear flood.....	5.00	12	C-5	C	800	8	5¼	16	15	19,500	19.5	

^a Life under specified test conditions.

^b Unsatisfactory lamp operation is likely to occur in burning positions between horizontal and base up, particularly between 45 deg. from base up, and base up.

TABLE 7.—LARGE MAZDA LAMPS AND TYPE D LAMPS.—(Continued)

Mazda Projector and Reflector Lamps—110, 115, and 120 Volts

Watts	Bulb	Base	Finish, color, or other description	List price	Std. pkg. qty.	Fil. const.	Mazda B or C lamp	Rated life, hr. ^a	Max. over-avg. length, in.	Approx. initial zone lumens	Initial max. beam candle power ^{ee}	Position of burning
Mazda Projector Spot Lamp												
150	PAR-38 ⁴⁴	Med. skt.	\$1.40	12	CC-6	C	1000	5½	990(0-15 deg.)	10,500	Any
Mazda Projector Flood Lamp												
150	PAR-38 ⁴⁴	Med. skt.	\$1.40	12	CC-6	C	1000	5½	1150(0-30 deg.)	2500	Any
Mazda Reflector Spot Lamps ^{ee}												
150	R-40	Med.	Light inside frosted.....	\$0.95	12	C-11	C	1000	6½	700(0-15 deg.)	7000	Any
300	R-40 ⁴⁴	Med.	Light inside frosted.....	1.70	12	{ CC-2 Horiz. }	C	1000	6½	1430(0-15 deg.)	16,000	Any
Mazda Reflector Flood Lamps ^{ee}												
150	R-40	Med.	Inside frosted.....	\$0.95	12	C-11	C	1000	6½	700(0-30 deg.)	1200	Any
300	R-40 ⁴⁴	Med.	Inside frosted.....	1.70	12	{ CC-2 Horiz. }	C	1000	6½	1600(0-30 deg.)	3000	Any

^a Life under specified test conditions.

^{ee} Readings taken at distance of 10 ft.

⁴⁴ Should be burned only in porcelain sockets.

^{ee} May not give satisfactory performance if any accessory lighting equipment is attached to, or touches, the glass bulb.

TABLE 7.—LARGE MAZDA LAMPS AND TYPE D LAMPS.—(Continued)
Mazda Lamps for Aviation Service

Watts	Bulb	Base	Volts	Finish, color, or other description	List price	Std. pkg. qty.	Fil. const.	Mazda B or Mazda lamp	Rated average life, hr.*	Max. over-all length, in.	Average light center length, in.	Approx. initial lumens	Rated initial lumens per watt	Position of burning
100	A-19	Md. pf.	12	Clear	\$ 1.70	12	C-2	C	100	4 ³ / ₈	13 ¹ / ₂	2200	21.8	*
240	A-19	Md. pf.	12	Clear	4.25	12	C-2	C	100	4 ¹ / ₈	13 ³ / ₄	5750	24.0	*
420	G-25	Mg. pf. Mog.	12	Clear	5.00	12	C-2	C	100	5 ³ / ₁₆	11 ¹ / ₁₆	10,500	25.0	*
			12	Clear	5.00	12	C-2	C	100	4 ⁷ / ₈	3	10,500	25.0	*
500	T-20	Mg. pf.	{ 110, 115, 120 }	Clear	3.96	6	C-13B	C	800	9 ¹ / ₂	3 ¹ / ₁₆	9000	18.0	Base down
1000	T-20	Mg. bip.	30	Clear	7.00	6	C-13	C	500	9 ¹ / ₂	4 ¹ / ₂	25,500	25.5	Base down
		Mg. bip. Mog.	{ 110, 115, 120 }	Clear	6.50	6	C-13	C	500	9 ¹ / ₂	4 ¹ / ₂	20,500	20.5	Base down
				Clear	6.50	6	C-13	C	500	9 ¹ / ₁₆	4 ³ / ₄	20,500	20.5	Base down
1500	T-24	Mg. bip.	32	Clear	15.00	6	C-13B	C	400	10 ¹ / ₂	4 ¹ / ₂	42,000	28.0	Base down
3000	T-32	Mg. bip.	32	Clear	22.00	4	C-13B	C	100	14	5 ³ / ₄ //	88,500	29.5	Base down
5000	G-64	Mg. bip.	{ 110, 115, 120 }	Clear	23.00	1	C-13	C	75	11 ⁷ / ₈	6 ³ / ₂ //	165,000	32.7	Base down
10,000	G-96	Mg. bip.	120	Clear	65.00	1	C-13	C	75	17 ³ / ₄	10 ¹ / ₂	325,000	32.7	Base down

* Life under specified test conditions.

• Can be burned in any position except within 45 deg. of vertically base up.

• The light center length of this lamp is the distance from center of light source to top of base fin.

// The light center length of this lamp is exclusive of base prongs, base prong being the small diameter part of metal post

TABLE 7.—LARGE MAZDA LAMPS AND TYPE D LAMPS.—(Continued)
Mazda Lamps for Street Series Service⁶⁷

Rated initial lumens	Bulb	Amperes	List price	Std. qty.	Fil. const.	Max. over-all length, in.	Average light center length, in.	Average volts	Average watts	Rated initial lumens per watt	Per cent lumens at 70% of rated life	Position of burning
1000	PS-25	6.6	\$0.40	60	C-8	7½	5¾	9.4	61.7	16.2	100	Any ^{AA}
2500	PS-35	6.6	.80	24	C-2	9¾	7	21.6	142.9	17.5	100	Any ^{AA}
4000	PS-35	6.6	.95	24	C-2	9¾	7	31.9	210.5	19.0	98	Any ^{AA} { Base up Base down
		15	1.05	24	C-2	9¾	6¼	13.5	203.0	19.7	95	
6000	PS-40	5.6	1.35	12	C-2	9¾	7	46.9	309.3	19.4	95	Any ^{AA} { Base up Base down
		20	1.45	12	C-2	9¾	6¼	14.7	294.1	20.4	94	
10,000	PS-40	20	1.85	12	C-7	9¾	7	24.4	487.8	20.5	91	{ Base up Base down
15,000	PS-40	20	2.55	12	C-7	9¾	7	35.7	714.3	21.0	85	{ Base up Base down
25,000	PS-52	20	4.80	6	C-7	13¼ ^e	9½	60.7	1213.6	20.6	80	Base up

⁶⁷ All street series lamps are gas filled, have clear bulbs and are fitted with mogul screw base. All standard street series lamps have an average rated life of 2000 hr.; because of the severity of street-lighting service, the average service life of street series lamps, even under good operating conditions, is of the order of 25 per cent less than the average laboratory life.

^{AA} Will operate in any position, but lumen maintenance is best when burned vertically base up, and the per cent lumens at 70 per cent of rated life, when shown, apply to this burning position only.

51. Operating Characteristics of Multiple Tungsten-filament Lamps.—The lumen output of a lamp is influenced greatly by the temperature of operation of the filament. At the higher temperatures more radiation occurs in the visible range of wave lengths, and hence the evaluation through the luminosity function yields a greater number of lumens. Obviously a means of obtaining a higher temperature of filament operation is through a greater power input to the filament. In a multiple type lamp (*i.e.*, one designed to be operated with others in parallel) this can be accomplished by increasing the voltage applied to the lamp.

The higher temperature of filament operation yields still another result. At the higher temperature the evaporation of the filament is more rapid. Hence the life of the filament becomes less at the higher temperature.

The balance between light and life is therefore the controlling consideration in the design and utilization of incandescent lamps. Details of filament design will not be dealt with in this text. Instead, empirical formulas obtained from numerous tests on lamps are presented in equations (94) to (96). An excellent consideration of the design of lamps is presented in "The Scientific Basis of Illuminating Engineering," by Parry Moon, for those desiring a more advanced treatment of the subject.

The operation of multiple incandescent lamps at other than rated voltages can be expressed rather accurately by the following empirical relationships, provided the voltage range considered is not excessive:

$$\frac{\varphi_1}{\varphi_2} = \left(\frac{V_1}{V_2} \right)^a \quad (94)$$

$$\frac{\mathcal{L}_1}{\mathcal{L}_2} = \left(\frac{V_1}{V_2} \right)^{-b} \quad (95)$$

$$\frac{P_1}{P_2} = \left(\frac{V_1}{V_2} \right)^c \quad (96)$$

where φ = luminous flux.

\mathcal{L} = life of the lamp.

P = power taken by the lamp.

V = voltage on the lamp.

The values of the exponents *a*, *b*, and *c* are given in Table 8 for the several lamp sizes and classifications.

TABLE 8.—EXPONENTS FOR USE IN EQUATIONS (94), (95), AND (96)

Classification of lamp	Exponent		
	<i>a</i>	<i>b</i>	<i>c</i>
Type B lamps.....	3.51	13.5	1.581
Type C 40-50-watt lamps.....	3.68	13.5	1.523
Type C 60-150-watt lamps.....	3.61	13.5	1.523
Type C lamps 200 watts and larger.....	3.38	13.1	1.543

52. Economics of Lamp-voltage Variation.—The lowest total cost of producing light by multiple incandescent lamps depends greatly upon the voltage of lamp operation with respect to the rated voltage of the lamp. Two costs must be considered: (1) the investment cost on the lamp, including its installation, and (2) the cost of electrical energy used by the lamp during its lifetime. Cost of the fixture and distribution circuits is not considered, since this cost is relatively independent of voltage of operation in the problem under consideration. The amount of light produced by the lamp during the same time interval is likewise of primary importance.

One obvious method of determining the most economical voltage of operation is the substitution of various voltages into equations (94) to (96) for a given set of conditions. From the data thus derived, the cost of producing 1 lumen-hour of light can be determined. If a plot of this data has a minimum point, the voltage at that point represents the most economical voltage of operation.

At very low voltages on the lamp, the operating cost per lumen-hour will be very high, since its efficiency in producing luminous flux is low; whereas the investment cost will be very low inasmuch as the life will be extremely long. At very high voltages the converse will be true, since the life of the lamp will be very short and the efficiency as a luminous-flux producer very high. Hence there *will be* some voltage giving a minimum over-all cost, this voltage representing the most economical voltage for the particular set of conditions.

A much simpler method of determining the most economical operating voltage is through the use of differential calculus.

Let q = cost of lamp including installation, in cents.

r = cost of electrical energy, in cents per kilowatt-hour.

V = voltage applied to lamp, in volts.

V_0 = rated voltage of lamp, in volts.

\mathcal{L} = life of lamp, in hours.

\mathcal{L}_0 = rated life of lamp, in hours.

P = power taken by lamp, in watts.

P_0 = rated power of lamp, in watts.

φ = luminous flux, in lumens.

φ_0 = luminous flux at rated voltage, in lumens.

The cost of installing and operating the lamp for \mathcal{L} hours at the voltage condition V (*i.e.*, for the life of the lamp) is

$$q + \left(\frac{rP\mathcal{L}}{1000} \right)$$

The luminous flux obtained (assumed constant over the life of the lamp) is φ lumens, and the amount of *light* obtained during the \mathcal{L} hours is $\varphi\mathcal{L}$. Therefore the cost per lumen-hour is

$$\text{Unit cost} \left(\frac{\text{cents}}{\text{lumen-hour}} \right) = \frac{q}{\varphi\mathcal{L}} + \frac{rP}{1000\varphi} \quad (97a)$$

Setting up equations (94) to (96) in terms of V , φ , \mathcal{L} , and P to their rated values gives

$$\varphi = \varphi_0 \left(\frac{V}{V_0} \right)^a \quad (94a)$$

$$\mathcal{L} = \mathcal{L}_0 \left(\frac{V}{V_0} \right)^{-b} \quad (95a)$$

$$P = P_0 \left(\frac{V}{V_0} \right)^c \quad (96a)$$

Substituting these values in equation (97) yields

$$\begin{aligned} \text{Unit cost} \left(\frac{\text{cents}}{\text{lumen hour}} \right) &= \frac{q}{\varphi_0\mathcal{L}_0} \left(\frac{V}{V_0} \right)^{-a} \left(\frac{V}{V_0} \right)^{+b} \\ &\quad + \frac{rP_0}{1000\varphi_0} \left(\frac{V}{V_0} \right)^c \left(\frac{V}{V_0} \right)^{-a} \\ &= \frac{qV_0^{(a-b)}}{\varphi_0\mathcal{L}_0} V^{(b-a)} + \frac{rP_0V_0^{(a-c)}}{1000\varphi_0} V^{(c-a)} \end{aligned} \quad (98)$$

For a given set of conditions concerning some particular lamp and energy cost, the only variable on the right-hand side of the equation is the voltage V . Hence a differentiation of cost with respect to this voltage will yield

$$\frac{d(\text{unit cost})}{dV} = \frac{qV_0^{(a-b)}}{\varphi_0 \mathcal{L}_0} (b - a) V^{(b-a-1)} + \frac{rP_0 V_0^{(a-c)}}{1000 \varphi_0} (c - a) V^{(c-a-1)} \quad (99)$$

When the unit cost does not change with respect to voltage, the condition of minimum unit cost is obtained (there being no limit on maximum cost). Hence

$$\frac{(b - a)qV_0^{(a-b)}}{\varphi_0 \mathcal{L}_0} V^{(b-a-1)} + \frac{(c - a)rP_0 V_0^{(a-c)}}{1000 \varphi_0} V^{(c-a-1)} = 0$$

or

$$V = \left[\left(\frac{a - c}{b - a} \right) \frac{rP_0 \mathcal{L}_0}{1000q} \right]^{\frac{1}{b-c}} V_0 \quad (100)$$

The expression is arranged so that all differences are positive as shown in equation (100). The most economical voltage will be dependent upon a combination of five items: (1) the cost of electrical energy; (2) the investment cost of the lamp; (3) the rated power of the lamp; (4) the rated life of the lamp; and (5) the exponents a , b , c of the equations for lamp performance. The only variation in the fifth item is the slight variation among the various lamp sizes and hence could be considered essentially a constant parameter of the problem.

A higher energy rate demands a higher operating voltage on a given lamp for most economical light production. The larger the rated power and the rated life for a series of lamps the higher is the most economical voltage. However, the greater the investment cost for a given lamp the lower is the most economical voltage.

If the value inside the brackets of equation (100) is equal to unity, then the economical voltage is the rated voltage. For such conditions the relationship involved among the power rate, the investment cost, the rated power, and the rated life for *Type C 60 to 150-watt lamps* is

$$4740q = rP_0 \mathcal{L}_0 \quad (101)$$

Even though a "nuisance cost" equal to several times the actual price of the lamp is included in q , the energy rate r necessary to justify lamp operation at the name-plate rating is surprisingly low on lamps rated at 100 watts or more. Usually operation at overvoltage is desirable. The use of 120-volt lamps on 115-volt circuits in order "to make them burn longer" is in practically all cases foolish economy.

The unit cost of producing light by a given lamp operating at its most economical voltage V is obtained through equation (98) with the value of V of equation (100) substituted therein. The result is

Unit cost at most economical voltage

$$= \frac{1}{\varphi_0} \left(\frac{rP_0}{1000} \right)^{k_1} \left(\frac{q}{\mathcal{L}_0} \right)^{k_2} (k_3^{k_1} + k_4^{k_2})$$

where

$$k_1 = \frac{b - a}{b - c}$$

$$k_2 = \frac{a - c}{b - c}$$

$$k_3 = \frac{a - c}{b - a}$$

$$k_4 = \frac{b - a}{a - c} = \frac{1}{k_3}$$

53. Effects of Filament Evaporation.—The evaporation of the filament of an incandescent lamp reduces the diameter of the filament and thus increases its electrical resistance. On a multiple lamp this increased resistance results in less current flow and also in less power input for a given voltage. Consequently the radiation process is retarded as the lamp is used. On a series lamp where the current is maintained independently of the resistance conditions, the increased resistance actually results in increased radiation as the lamp is used.

The blackening of the bulb of the lamp due to the deposit of the tungsten on the glass acts as a filter and hence tends to reduce the radiant power leaving the bulb surface. On multiple lamps the effect of reduced radiation from the filament, and the blackening of the bulb, is to reduce the lumen output of the lamp to about 70 per cent of the initial lumen output at rated life. On series lamps the two effects more or less cancel each other,

giving on larger lamps only a slight increase in lumen output with aging of the filament. On small series lamps the blackening of the bulb usually predominates over the increased radiation, thus giving a slight decrease in lumens output as the lamp ages.

54. Vapor Lamps.—These lamps, which produce luminous flux by virtue of electrical-current flow through a gas or a vapor, may be divided into two groups: (1) these operating with a cold cathode and (2) those operating with a hot cathode.

Lamps of the cold-cathode type comprise the "neon" lamps so common in advertising signs. Helium and mercury are used in a great many of these so-called neon signs in addition to neon. Argon is usually used in most of them as a carrier gas to assist in starting the electrical discharge. Various colored glass tubes are incorporated to obtain the myriad possibilities of neon-tube lighting. The lamp has an inherently large cathode voltage drop which causes a correspondingly large power consumption with no emission of light from that region of the lamp. Hence the lamps are usually built only in relatively high-voltage units and even then are not so efficient as the hot-cathode type.

Sodium- and mercury-vapor lamps are the outstanding commercial lamps of the hot-cathode type, although neon, argon, helium, and several other gases or vapors are being used. The remaining discussion will be concerned with the sodium- and mercury-vapor lamps and others of the mercury type.

55. Mercury-vapor Lamps.—Early mercury-vapor lamps operated at a mercury pressure of approximately 0.025 mm. The efficiency of the units as luminous-flux producers was such that approximately 13 lumens per watt were obtained by a device rated at 450 watts. The present-day mercury-vapor unit operates at a much higher mercury pressure on the commercial sizes the pressure being approximately 1 atmosphere when the lamp has attained its full operating temperature. Two sizes of these units are available: a 400-watt lamp and a 250-watt lamp. Both are self-contained except for the ballast equipment necessary to give stable operation on constant-voltage circuits.

The 400-watt lamp consists of two tubular bulbs—one within the other. At each end of the inner bulb is an electrode consisting of a coil of tungsten wire treated with a mixture of barium compounds. This treatment serves to produce a copious supply of electrons when the lamp is in its initial stage of operation. In

addition to the two main electrodes there is an auxiliary electrode located close to the regular electrode at that end of the tube nearer the base. This electrode is connected to that located at the opposite end of the inner tube through a fixed resistor of 15,000 ohms. Its action is to assure positive starting in cold weather and to reduce the time required for restarting following current interruption. A very carefully measured amount of mercury and a small amount of argon gas completes the inner-bulb assembly. The argon gas facilitates the establishment of the arc discharge at the initial starting period. The outer tube serves as a heat-insulating jacket.

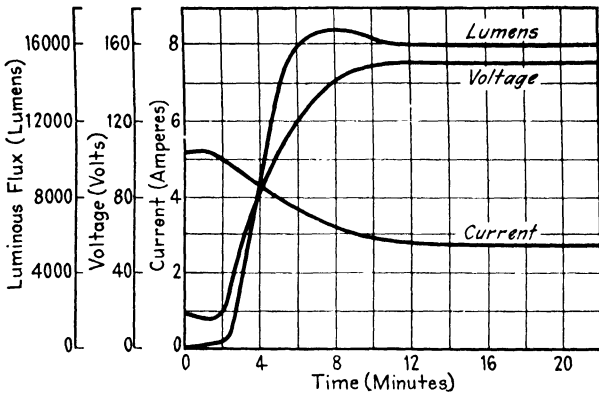

FIG. 92.—Starting characteristic of a 400-watt mercury-vapor lamp.

For a period of several minutes after the arc is established the lamp requires approximately 20 volts at 5 amp. as is shown in Fig. 92. After some 10 or 12 min. the normal operating condition is reached when the lamp requires approximately 150 volts at 2.7 amp. The amount of luminous flux output is also shown in Fig. 92.

Should an interruption in the electrical service take place while the lamp is in operation, the arc will be quenched and cannot be reestablished until the lamp has cooled sufficiently to reduce the mercury-vapor pressure to a critical point.

Some form of ballast equipment is necessary for stable operation of the lamp. For a 230-volt supply this ballast may take the form of a reactor connected in series with the lamp. For 115-volt supply a transformer possessing high regulation is necessary, since the operating voltage of the lamp is higher than

the line voltage. The ballast equipment adds approximately 40-watts loss making the total power supplied to the combination when the lamp is at full operating condition approximately 440 watts.

Inasmuch as the power factor of the lamp and the ballast equipment is of the order of 60 per cent, capacitors are often used to increase the power factor to approximately 90 per cent.

The 250-watt mercury-vapor lamp is used for installations where a low hanging height is necessary. The brightness of the 400-watt lamp is such that even with large diffusing fixtures the

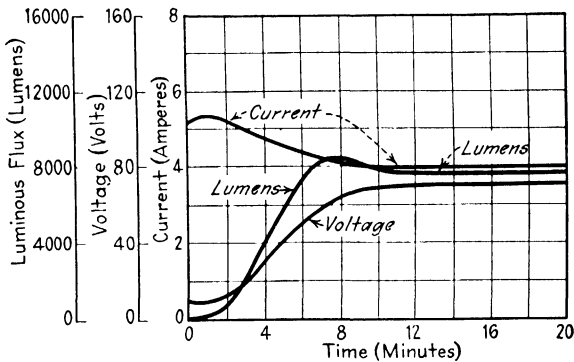

FIG. 93.—Starting characteristic of a 250-watt mercury-vapor lamp.

glare would be prohibitive. The efficiency of the smaller unit does not match that of the 400-watt unit.

The smaller lamp consists of a single bulb with electrode arrangement very similar to that of the 400-watt unit. The end of the bulb opposite the base is coated with a very thin layer of platinum which in turn carries a protective coating. The platinum coating is essential in order that heat may be reflected back into the lamp, thereby preventing any condensation of mercury from taking place at the tipped end. The pressure of operation is approximately 300 mm. The starting characteristic is shown in Fig. 93. The lamp is used only in enclosing fixtures.

Mercury-vapor lamps both larger and smaller than the 250- or 400-watt size are commercially available. The smaller size carries a 100-watt rating with an initial luminous efficacy of 32 lumens per watt. The lumen maintenance at 70 per cent rated life on this lamp is considerably less than for the others, as is

TABLE 8a.—MERCURY-VAPOR LAMPS
Masda H Lamps

(For use only with specially designed auxiliary equipment to produce proper electrical values)

Approx. lamp watts ^a	Outer bulb	Inner bulb	Base	Lamp no.	List price	Std. pkg. qty.	Rated average life, hr.	Max. over-all length, in.	Aver- age light center length, in.	Approx. length of light source, in.	Approx. initial lumens ^b	Lumens per watt ^b		Position of burning
												Rated initial	At 70% rated life	
100	T-10 clear ^c	T-3 quartz.	Adimed.	A-H4	\$ 9.50	6	1000 ^d	5½	3½ e	1	3500*	32*	22	Any
250	T-9 clear ^c	None	Med.	A-H2	8.50	12	2000 ^d	8	5	4½	7500*	28*	25	Any
400	T-16 clear ^c	T-11 ^c	Mog.	A-H1	11.00	6	3000 ^d	13	7¾	6	16,000*	40*	34	Base up/
400	T-16 clear ^c	T-11 ^c	Mog.	B-H1	11.00	6	3000 ^d	13	7¾	6	16,000*	40*	34	Base down/
1000	Water jacket required ^f	T-2 quartz.	Sl-ve	A-H6	9.00	6	75 ^g	3¾		1	65,000*	65	52	Horizontal

^a For total, add auxiliary watts.

^b Approximate lumens and lumens per watt under specific test conditions.

^c Heat-resisting glass bulb.

^d Life under specified test conditions with lamps turned off and restarted no oftener than once every 5 burning hours.

^e Initial lumens and lumens per watt apply at the end of 100 hr. of operation.

^f Burning position must be within 10 deg. of vertical.

^g Use only approved type water-cooling jackets.

^h Life under specified test conditions with lamps turned off and restarted no oftener than once every 25 burning minutes.

videnced in Table 8a. Data given here are from the General Electric Company schedule of March, 1941.

In the past two years the type A-H6, 1000-watt, high-pressure, mercury-vapor lamp has received considerable application where an extremely bright, small source is desirable. This lamp has a quartz bulb with an inside diameter of 2 mm. and an arc gap 5 mm. long. The lamp requires a water jacket and a forced cooling system.

Whereas the operating pressure on the standard 250- and 400-watt sizes is in the order of 1 atmosphere, the pressure in the 1000-watt lamp is approximately 75 atmospheres when steady-state operating conditions are attained. When mercury lamps are operated at such high pressures, the spectral-line characteristics of mercury radiation are no longer sharp. Instead they become broadened, and the spectrum between the lines is filled in with what has been called *background radiation*. Pressures as high as nearly 300 atmospheres have been investigated, and at this pressure nearly all trace of the line character of the spectrum is lost. As a result many colored objects illuminated by this source appear more natural in hue than would they under the lower pressure 250- or 400-watt lamps. However, at the extremely high pressure of 300 atmospheres, for example, the life of the lamp is extremely short. If the life can be increased when operating at such pressure, the lamp will undoubtedly be applied in many more fields. At the present it is rather limited to those applications where color itself may be of small importance, as in photochemical processes, television studios, searchlights, certain picture projection applications, and high-speed oscillographs.

56. Sodium-vapor Lamps.—The sodium-vapor lamp consists of an evacuated tubular bulb enclosing at each end a coiled tungsten filament (the cathode) and a sleeve of molybdenum (the anode). Each cathode is coated with an active material to give off electrons freely when heated. Each anode is connected to one side of the respective filament coils and acts as a collector during the half cycle when that end of the tube is positive with respect to the other. A small quantity of sodium and also neon at a few millimeters pressure (for starting) are included in the bulb.

The heat insulation so necessary for vapor lamps is furnished by a separate, heat-resistant, double-walled flask which encloses the lamp during operation.

To operate the lamp each cathode is first supplied with 6.6 amp. at approximately 2.5 volts. This is accomplished by shorting out the arc by a timer relay as is shown in Fig. 94. After a short preheating interval, the arc potential is applied across the anodes. This is usually accomplished through a timing device

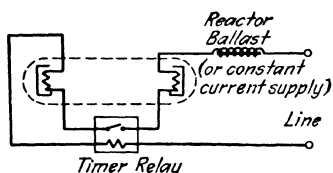

FIG. 94.—Sodium lamp circuit.

operated by a bimetallic element. After opening the circuit the relay is held open as long as the unit is in operation. When the voltage is first applied across the electrodes, the lamp glows with the characteristic red neon color. As the temperature rises and the sodium becomes vaporized, the discharge gradually acquires the orange-yellow of the sodium arc. The maximum luminous output is reached in about 30 min. The lamp does not require a cooling period for reestablishment of the arc following a power interruption.

57. Fluorescent Lamps.—The fluorescent lamp is a form of the mercury-vapor lamp with an additive feature. In the fluorescent lamp the mercury-vapor pressure is of the order of magnitude of 0.003 mm. If clear glass were used, the luminous output would be approximately 5 lumens per watt. However, this low pressure of operation produces radiation having a very large

TABLE 9.—DATA ON FLUORESCENT CHEMICALS^a

Phosphor ^b	General color	Exciting range, ^c microns	Sensitivity peak, microns	Emitted range, microns	Emitted peak, microns
Calcium tungstate..	Blue	0.22-0.30	0.2720	0.38-0.70	0.440
Magnesium tungstate.....	Blue-white	0.22-0.32	0.2850	0.38-0.72	0.480
Zinc silicate.....	Green	0.22-0.30	0.2537	0.45-0.62	0.525
Zinc beryllium silicate.....	Yellow-white	0.22-0.30	0.2537	0.45-0.72	0.595
Cadmium silicate...	Yellow-pink	0.22-0.32	0.2400	0.43-0.72	0.595
Cadmium borate...	Pink	0.22-0.36	0.2500	0.40-0.72	0.615

^a From "Engineering Data on Fluorescent Mazda Lamps," General Electric Company, Cleveland.

^b In addition to phosphor, manganese is usually present as an activator.

^c Minimum measurements taken, 0.22 μ .

mount of power radiated at a wave length of 0.2537μ . Various phosphors are used which respond to excitation of this wave length and which emit in the visible range. Data on several fluorescent chemicals are given in Table 9. The powders used in fluorescent lamps are white by reflected light. The gold and red lamps have additional coatings of colored pigment to enhance the desired hues with the phosphors now available. Data on fluorescent lamps from the General Electric Company schedule of March, 1941, are presented in Table 10.

The starting device is similar to that of the sodium-vapor lamp in that the arc is shorted initially by a starting switch. Many variations of these starting switches are possible. The type now used most generally is the thermal glow switch. On starting, the line voltage across the starter switch is sufficient to produce a glow discharge between a bimetal strip and an adjacent electrode. The heat thus produced by the glow causes the bimetal strip to deflect against the other electrode. This permits sufficient current to flow through the lamp-cathode heating circuit to heat the cathodes. In the meantime the glow discharge has been shorted out allowing the bimetal strip to cool and the contact between bimetal strip and its adjacent electrode is soon broken. As in other mercury lamps a ballast is required in the circuit, and the inductive kick from this ballast as the contacts open starts the main discharge current in the lamp. Once the lamp is started, the voltage upon the switch is insufficient thereafter to cause a glow discharge so the starter consumes no energy during lamp operation. Prices of starters for the various size lamps are given in Table 11. Data in Tables 11 through 16 are from "Fluorescent Mazda Lamps and Auxiliary Equipments," General Electric Company, Folder 1, April, 1941. Enclosed within the case of the starter is a small condenser for reducing radio interference.

Various types of ballast are available for operating either one or two lamps. Circuits for these are shown in Figs. 95 to 104 inclusive. The voltage of the supply, the lamp size, whether power-factor corrected with capacitors, and whether single- or two-lamp operation is desired are factors influencing the choice of ballasts and the associated circuits. Data on ballasts as regards their use with lamps of various sizes, circuit voltage, significant physical and electrical data, and prices are given in

TABLE 10.—FLUORESCENT LAMPS
 Mazda F Lamps (Fluorescent Lamps)
 (For use only with specially designed auxiliary equipment to produce proper electrical values)

Bulb	Approx. lamp watts*	Base	Finish, color, or other description	List price	Std. pkg. qty.	Rated average life, hr. ^b	Approx. initial lumens ^c	Lumens per Watt ^d		Position of burning	
								Rated initial	At 70% rated life		
18 in.—T-8 (1 in. diameter)	15	Med. bipin	Daylight.....	\$0.85	24	2500	495	33	26	Any	
			3500° white.....	0.85	24	2500	615	41	33	Any	
			Blue.....	0.95	24	2500	Any
			Green.....	0.95	24	2500	Any
			Pink.....	0.95	24	2500	Any
24 in.—T-12 (1½ in. diameter)	20	Med. bipin	Daylight.....	1.10	24	2500	730	36.5	30	Any	
			3500° white.....	1.10	24	2500	900	45	37	Any	
			Blue.....	1.20	24	2500	Any
			Green.....	1.20	24	2500	Any
			Pink.....	1.20	24	2500	Any
36 in.—T-8 (1½ in. diameter)	30	Med. bipin	Daylight.....	1.30	24	2500	Any	
			3500° white.....	1.30	24	2500	Any
			Blue.....	1.10	24	2500	1200	40	32	Any	
			Green.....	1.20	24	2500	1450	49	39	Any	
			Pink.....	1.20	24	2500	Any
48 in.—T-12 (1½ in. diameter)	40	Med. bipin	Daylight.....	1.30	24	2500	Any	
			3500° white.....	1.30	24	2500	Any
			Blue.....	1.60	24	2500	1700	42	36	Any	
			Green.....	1.60	24	2500	2100	52	44	Any	
			Pink.....	1.60	24	2500	Any
60 in.—T-17 (2½ in. diameter)	100	Mor. bipin	Daylight.....	3.50	12	2000	3350	33.5	29	Any	
			3500° white.....	3.50	12	2000	4200	42	36	Any	

* For total, add auxiliary watts.

^b Life under specified test conditions.

^c Approximate lumens and lumens per watt when measured at 80°F. ambient and under specified test conditions.

^d Initial values apply at the end of 100 hr. of operation.

Tables 12 and 12a. The prevalence of 60-cycle a.c. circuits makes the ballast equipment designed for this frequency the

TABLE 11.—REPLACEABLE FLUORESCENT STARTERS

Type	FS-5	FS-2	FS-4	FS-74	FS-64	FS-6
Lamp size....	{ 6-watt 8-watt }	15-watt 20-watt	{ 30-watt 40-watt }	65-watt	100-watt	100-watt
Starter list price, each.	\$0.40	\$0.36	\$0.36	\$0.80	\$0.80	\$0.80
Number of starter contacts.	2	2	2	4	4	For replacement in 2-contact starter sockets

most common. However, for 50-cycle, a.c. service special auxiliaries are available as is indicated in these tables. At

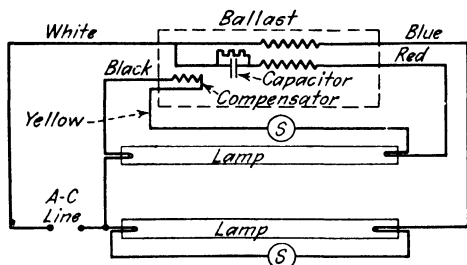

FIG. 95.—Fifteen- and twenty-watt tulamp circuit with integral starting compensator.

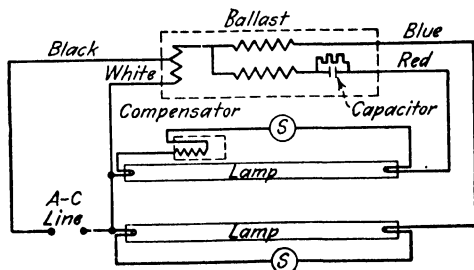

FIG. 96.—Thirty- and forty-watt tulamp circuit showing separate compensator.

25 cycles the flicker that results from the cyclic action upon the phosphors of the fluorescent lamp is intolerable. Consequently

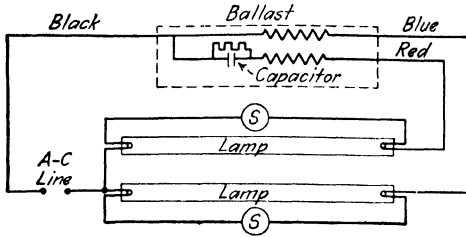

FIG. 97.—Sixty-five-watt tulamp circuit.

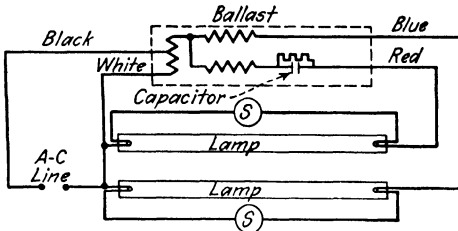

FIG. 98. One hundred-watt tulamp circuit.

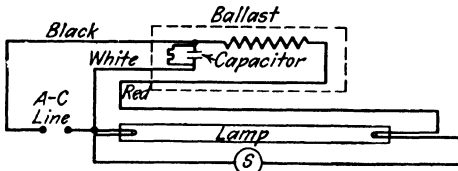

FIG. 99.—Fifteen- and twenty-watt high power-factor single-lamp circuit. Also 30- and 40-watt 199-216 and 220-250 volts.

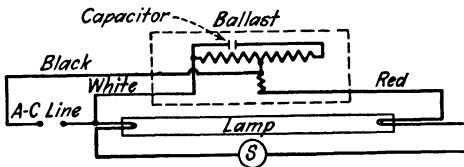

FIG. 100.—Sixty-five-watt high power-factor single-lamp circuit.

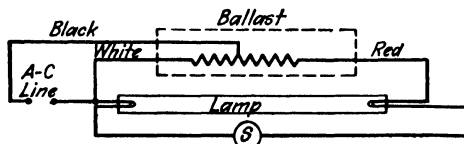

FIG. 101.—Autotransformer type, 30 and 40 watts, 110-125 volts.

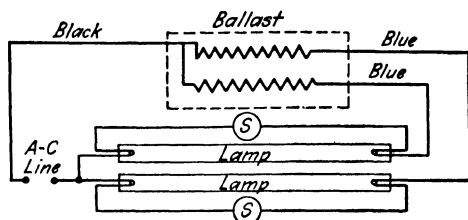

FIG. 102.—Fifteen- and twenty-watt two-multiple low power-factor circuit.

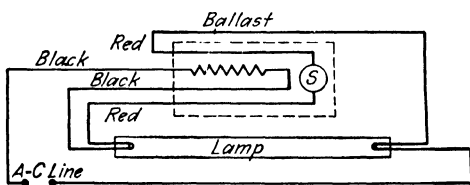

FIG. 103.—Six- and eight-watt circuit.

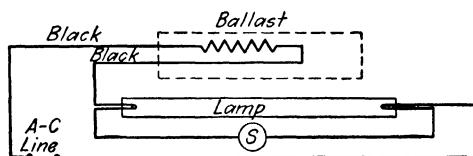

FIG. 104.—Fifteen- and twenty-watt single-lamp low-power-factor circuit; thirty- and forty-watt for 199-216 and 220-250 volts. Also 65-watt.

these lamps are not used on circuits of 25 cycles, although with proper ballast equipment the lamps themselves will operate. As a result auxiliaries for 25 cycles are not commercially available.

The ballasts of Table 12 contain capacitors for power-factor correction. The ballasts of Table 12a are not power-factor corrected. However, capacitors as separate units are available for such correction. Table 13 lists several of these capacitors together with the units to be used for correcting various size lamps.

Tables 14 and 15 extend the data of Table 10 somewhat as regards the smaller lamp sizes available. The lumen outputs for the colored lamps are also given.

Table 16 contains information relative to the maximum brightness of the various lamps as measured at the center of the lamp and perpendicular to the lamp.

58. Operating Characteristics of Fluorescent Lamps.—As for incandescent lamps, the operating conditions of fluorescent lamps

TABLE 12.—HIGH-POWER-FACTOR BALLASTS

High-power-factor Tulamp Ballasts—60 Cycles

Lamp watts	Circuit voltage	Size, in.	Weight, lb.	Approx. watts loss	Approx. power factor	List price each
2-15	110-125	1 $\frac{1}{2}$ $\frac{3}{4}$ × 2 $\frac{1}{4}$ × 14 $\frac{1}{4}$	3 $\frac{3}{8}$	9	95-100	\$ 3.50
2-20	110-125	1 $\frac{1}{2}$ $\frac{3}{4}$ × 2 $\frac{1}{4}$ × 14 $\frac{1}{4}$	3 $\frac{3}{8}$	9	95-100	3.50
2-30	110-125	2 $\frac{3}{8}$ × 3 $\frac{1}{8}$ × 9 $\frac{1}{2}$	7	14 $\frac{1}{2}$	95-100	4.25
2-30	199-216	2 $\frac{3}{8}$ × 3 $\frac{1}{8}$ × 9 $\frac{1}{2}$	6 $\frac{3}{4}$	12	95-100	4.25
2-30	220-250	2 $\frac{3}{8}$ × 3 $\frac{1}{8}$ × 9 $\frac{1}{2}$	6 $\frac{3}{4}$	12 $\frac{1}{2}$	95-100	4.25
2-30	110-125	1 $\frac{5}{8}$ × 2 $\frac{1}{4}$ × 22 $\frac{1}{2}$ $\frac{1}{8}$ ^{a,b}	7	18	95-100	6.25
2-30	199-216	1 $\frac{5}{8}$ × 2 $\frac{1}{4}$ × 22 $\frac{1}{2}$ $\frac{1}{8}$ ^{a,b}	7	10 $\frac{1}{2}$	95-100	6.25
2-30	220-250	1 $\frac{5}{8}$ × 2 $\frac{1}{4}$ × 22 $\frac{1}{2}$ $\frac{1}{8}$ ^{a,b}	7	14	95-100	6.25
2-40	110-125	2 $\frac{3}{8}$ × 3 $\frac{1}{8}$ × 9 $\frac{1}{2}$	7	17 $\frac{1}{2}$	95-100	4.50
2-40	199-216	2 $\frac{3}{8}$ × 3 $\frac{1}{8}$ × 9 $\frac{1}{2}$	6 $\frac{3}{4}$	13 $\frac{1}{2}$	95-100	4.50
2-40	220-250	2 $\frac{3}{8}$ × 3 $\frac{1}{8}$ × 9 $\frac{1}{2}$	6 $\frac{3}{4}$	14 $\frac{1}{2}$	95-100	4.50
2-40	110-125	1 $\frac{5}{8}$ × 2 $\frac{1}{4}$ × 22 $\frac{1}{2}$ $\frac{1}{8}$ ^{a,b}	7	25 $\frac{1}{2}$	95-100	6.50
2-40	199-216	1 $\frac{5}{8}$ × 2 $\frac{1}{4}$ × 22 $\frac{1}{2}$ $\frac{1}{8}$ ^{a,b}	7	16	95-100	6.50
2-40	220-250	1 $\frac{5}{8}$ × 2 $\frac{1}{4}$ × 22 $\frac{1}{2}$ $\frac{1}{8}$ ^{a,b}	7	20	95-100	6.50
2-65	110-125	2 $\frac{3}{8}$ × 3 $\frac{1}{8}$ × 14 $\frac{1}{4}$	14 $\frac{1}{4}$	24	95-100	7.50
2-100	110-125	2 $\frac{3}{8}$ × 3 $\frac{1}{8}$ × 19 $\frac{1}{4}$	14 $\frac{1}{2}$	35	95-100	11.50
2-100	199-216	2 $\frac{3}{8}$ × 3 $\frac{1}{8}$ × 19 $\frac{1}{4}$	14 $\frac{1}{2}$	35	95-100	11.50
2-100	220-250	2 $\frac{3}{8}$ × 3 $\frac{1}{8}$ × 19 $\frac{1}{4}$	14 $\frac{1}{2}$	35	95-100	11.50

50 Cycles*

2-15	110-125	1 $\frac{1}{2}$ $\frac{3}{4}$ × 2 $\frac{1}{4}$ × 17 $\frac{1}{2}$	3 $\frac{3}{4}$	10	95-100	\$ 5.00
2-20	110-125	1 $\frac{1}{2}$ $\frac{3}{4}$ × 2 $\frac{1}{4}$ × 17 $\frac{1}{2}$	3 $\frac{3}{4}$	10	95-100	5.00
2-30	110-125	2 $\frac{3}{8}$ × 3 $\frac{1}{8}$ × 9 $\frac{1}{2}$	7 $\frac{1}{2}$	15	95-100	5.75
2-30	220-250	2 $\frac{3}{8}$ × 3 $\frac{1}{8}$ × 9 $\frac{1}{2}$	7 $\frac{1}{2}$	13	95-100	5.75
2-30	110-125	1 $\frac{5}{8}$ × 2 $\frac{1}{4}$ × 22 $\frac{1}{2}$ $\frac{1}{8}$ ^{a,b}	7 $\frac{1}{2}$	18 $\frac{1}{2}$	95-100	8.00
2-30	220-250	1 $\frac{5}{8}$ × 2 $\frac{1}{4}$ × 22 $\frac{1}{2}$ $\frac{1}{8}$ ^{a,b}	7	15	95-100	8.00
2-40	110-125	2 $\frac{3}{8}$ × 3 $\frac{1}{8}$ × 9 $\frac{1}{2}$	7 $\frac{1}{2}$	18 $\frac{1}{2}$	95-100	6.00
2-40	220-250	2 $\frac{3}{8}$ × 3 $\frac{1}{8}$ × 9 $\frac{1}{2}$	7 $\frac{1}{2}$	15	95-100	6.00
2-40	110-125	1 $\frac{5}{8}$ × 2 $\frac{1}{4}$ × 22 $\frac{1}{2}$ $\frac{1}{8}$ ^{a,b}	7 $\frac{1}{2}$	28 $\frac{1}{2}$	95-100	8.25
2-40	220-250	1 $\frac{5}{8}$ × 2 $\frac{1}{4}$ × 22 $\frac{1}{2}$ $\frac{1}{8}$ ^{a,b}	7	21 $\frac{1}{2}$	95-100	8.25
2-65	110-125	2 $\frac{3}{8}$ × 3 $\frac{1}{8}$ × 14 $\frac{1}{4}$	11 $\frac{1}{4}$	26	95-100	10.00
2-100	110-125	2 $\frac{3}{8}$ × 3 $\frac{1}{8}$ × 19 $\frac{1}{4}$	15 $\frac{1}{2}$	37	95-100	15.00
2-100	220-250	2 $\frac{3}{8}$ × 3 $\frac{1}{8}$ × 19 $\frac{1}{4}$	15 $\frac{1}{2}$	37	95-100	15.00

Starting Compensator^c

.....	1 $\frac{1}{2}$ × 1 $\frac{1}{4}$ × 4 $\frac{1}{4}$	$\frac{3}{4}$	\$ 0.70
-------	-------	---	---------------	-------	-------	---------

High-power-factor Single-lamp Ballasts—60 Cycles

15	110-125	1 $\frac{1}{2}$ $\frac{3}{4}$ × 2 $\frac{1}{4}$ × 8 $\frac{3}{4}$	1 $\frac{1}{2}$	4 $\frac{1}{2}$	All 90 per cent lagging or higher at rated volts	\$ 2.50
20	110-125	1 $\frac{1}{2}$ $\frac{3}{4}$ × 2 $\frac{1}{4}$ × 8 $\frac{3}{4}$	1 $\frac{1}{2}$	4 $\frac{1}{2}$		2.50
30	110-125	1 $\frac{1}{2}$ $\frac{3}{4}$ × 2 $\frac{1}{4}$ × 14 $\frac{1}{4}$	3 $\frac{1}{2}$	10		3.75
30	199-216	1 $\frac{1}{2}$ $\frac{3}{4}$ × 2 $\frac{1}{4}$ × 10 $\frac{5}{8}$	2 $\frac{1}{2}$	8		3.00
30	220-250	1 $\frac{1}{2}$ $\frac{3}{4}$ × 2 $\frac{1}{4}$ × 10 $\frac{5}{8}$	2 $\frac{1}{2}$	9		3.00
40	110-125	1 $\frac{1}{2}$ $\frac{3}{4}$ × 2 $\frac{1}{4}$ × 14 $\frac{1}{4}$	3 $\frac{1}{2}$	13		4.00
40	199-216	1 $\frac{1}{2}$ $\frac{3}{4}$ × 2 $\frac{1}{4}$ × 10 $\frac{5}{8}$	2 $\frac{1}{2}$	12		3.25
40	220-250	1 $\frac{1}{2}$ $\frac{3}{4}$ × 2 $\frac{1}{4}$ × 10 $\frac{5}{8}$	2 $\frac{1}{2}$	13		3.25
65	110-125	2 $\frac{3}{8}$ × 3 $\frac{1}{8}$ × 14 $\frac{1}{4}$	9 $\frac{1}{2}$	24		6.00
100	110-125	2 $\frac{3}{8}$ × 3 $\frac{1}{8}$ × 14 $\frac{1}{4}$	10 $\frac{1}{2}$	24		8.00
100	199-216	2 $\frac{3}{8}$ × 3 $\frac{1}{8}$ × 14 $\frac{1}{4}$	10 $\frac{1}{2}$	24	8.00	
100	220-250	2 $\frac{3}{8}$ × 3 $\frac{1}{8}$ × 14 $\frac{1}{4}$	10 $\frac{1}{2}$	24	8.00	

50 Cycles^d

65	110-125	2 $\frac{3}{8}$ × 3 $\frac{1}{8}$ × 14 $\frac{1}{4}$	10 $\frac{1}{4}$	26	90 per cent or higher	\$ 8.00
100	110-125	2 $\frac{3}{8}$ × 3 $\frac{1}{8}$ × 14 $\frac{1}{4}$	11	31		11.00
100	220-250	2 $\frac{3}{8}$ × 3 $\frac{1}{8}$ × 14 $\frac{1}{4}$	11	34 $\frac{1}{2}$		11.00

* Note that 30-, 40- and 100-watt tulamp ballasts for 50 cycles are $\frac{1}{4}$ in. higher than corresponding 60-cycle ballasts.

^b Small cross section.

^c Starting compensator necessary for 30- and 40-watt tulamp ballasts.

^d Note that 65- and 100-watt single-lamp high power-factor ballasts for 50 cycles are $\frac{1}{4}$ in. higher than corresponding 60-cycle ballasts.

are influenced greatly by the voltage supplied to the circuit. However, the over-all efficiency of the fluorescent lamp and its

TABLE 12a.—UNCORRECTED-POWER-FACTOR BALLASTS
Single-lamp Ballasts—60 Cycles^a

Lamp watts	Circuit voltage	Size, in.	Weight, lb.	Approx. watts loss	Approx. power factor	List price, each
5	110-125	1 $\frac{3}{16}$ × 1 $\frac{3}{4}$ × 4 $\frac{1}{4}$	1	2	45	\$1.15
8	110-125	1 $\frac{3}{16}$ × 1 $\frac{3}{4}$ × 4 $\frac{1}{4}$	1	2.8	50	1.15
15	110-125	1 $\frac{7}{32}$ × 1 $\frac{3}{4}$ × 4 $\frac{1}{4}$	$\frac{3}{4}$	4 $\frac{1}{2}$	55	0.60
20	110-125	1 $\frac{7}{32}$ × 1 $\frac{3}{4}$ × 4 $\frac{1}{4}$	$\frac{3}{4}$	4 $\frac{1}{2}$	55	0.60
30	110-125	1 $\frac{7}{32}$ × 2 $\frac{1}{4}$ × 8 $\frac{3}{4}$	2 $\frac{1}{4}$	10	55	2.00
30	199-216	1 $\frac{7}{32}$ × 1 $\frac{3}{4}$ × 6 $\frac{1}{2}$	1 $\frac{1}{2}$	9	60	1.25
30	220-250	1 $\frac{7}{32}$ × 1 $\frac{3}{4}$ × 6 $\frac{1}{2}$	1 $\frac{1}{2}$	9	60	1.25
40	110-125	1 $\frac{7}{32}$ × 2 $\frac{1}{4}$ × 8 $\frac{3}{4}$	2 $\frac{1}{4}$	13	60	2.25
40	199-216	1 $\frac{7}{32}$ × 1 $\frac{3}{4}$ × 6 $\frac{1}{2}$	1 $\frac{1}{2}$	12	60	1.50
40	220-250	1 $\frac{7}{32}$ × 1 $\frac{3}{4}$ × 6 $\frac{1}{2}$	1 $\frac{1}{2}$	13	60	1.50
65	110-125	1 $\frac{7}{32}$ × 2 $\frac{1}{4}$ × 14 $\frac{1}{4}$	3 $\frac{3}{4}$	15	45	3.00

50 Cycles

6	110-125	1 $\frac{3}{16}$ × 1 $\frac{3}{4}$ × 4 $\frac{1}{4}$	1	2 $\frac{1}{4}$	45	\$1.50
8	110-125	1 $\frac{3}{16}$ × 1 $\frac{3}{4}$ × 4 $\frac{1}{4}$	1	3	50	1.50
15	110-125	1 $\frac{7}{32}$ × 1 $\frac{3}{4}$ × 6 $\frac{1}{2}$	1 $\frac{1}{2}$	6 $\frac{1}{2}$	55	1.25
20	110-125	1 $\frac{7}{32}$ × 1 $\frac{3}{4}$ × 6 $\frac{1}{2}$	1 $\frac{1}{2}$	7 $\frac{1}{2}$	55	1.25
30	110-125	1 $\frac{7}{32}$ × 2 $\frac{1}{4}$ × 8 $\frac{3}{4}$	2 $\frac{3}{8}$	15	55	3.00
30	220-250	1 $\frac{7}{32}$ × 1 $\frac{3}{4}$ × 8 $\frac{3}{4}$	2 $\frac{1}{4}$	13 $\frac{1}{2}$	60	2.00
40	110-125	1 $\frac{7}{32}$ × 2 $\frac{1}{4}$ × 10 $\frac{3}{4}$	3 $\frac{1}{4}$	19	60	3.25
40	220-250	1 $\frac{7}{32}$ × 1 $\frac{3}{4}$ × 8 $\frac{3}{4}$	2 $\frac{1}{4}$	15 $\frac{1}{2}$	60	2.25
65	110-125	1 $\frac{7}{32}$ × 2 $\frac{1}{4}$ × 14 $\frac{1}{4}$	4 $\frac{1}{2}$	17	45	4.50

Thermal-switch Auxiliary for Direct-current Operation

15-20	110-125	1 $\frac{3}{16}$ × 1 $\frac{3}{4}$ × 7 $\frac{3}{16}$	1 $\frac{1}{4}$	\$1.60 ^b
-------	---------	---	-----------------	------	----	---------------------

Low-power-factor Two-multiple Ballasts

2-15	110-125	1 $\frac{7}{32}$ × 1 $\frac{3}{4}$ × 6 $\frac{1}{2}$	1 $\frac{1}{2}$	9	55	\$1.10
2-20	110-125	1 $\frac{7}{32}$ × 1 $\frac{3}{4}$ × 6 $\frac{1}{2}$	1 $\frac{1}{2}$	9	55	1.10

^a See listing of FL capacitors recommended for correcting power factor in Table 13.

^b Does not include necessary external resistor.

auxiliaries increases with reduced voltage rather than decreases as for the incandescent lamp. Efficiency and stability are

opposing factors in the design of fluorescent lamp ballasts. Consequently a reduction in supply voltage for a given lamp and ballast, although increasing the efficiency, likewise reduces the margin of safety as regards stability. Consequently the recommended voltage range is usually considered from 110 to 125

TABLE 13.—CAPACITORS FOR POWER-FACTOR CORRECTION OF FLUORESCENT LAMPS

a	Catalogue No.	Capacity, microfarads	Volts	Cross section, in.	Over-all length, in.	List price, each
A	21F138	4.75	{118} {236}	1¼ × 2¼	5½	\$1.55
B	21F181	6.5	118	1¼ × 2¼	5½	1.65
C	21F182	11	118	1¼ × 2¼	6 ¹³ / ₁₆	2.30
D	21F122	17.5	{118} {236}	1¼ × 2¼	14 ¹ / ₁₆	3.50
E	21F123	28	118	1¼ × 2¼	14 ¹ / ₁₆	4.00

Lamp size	Volts	Class FL Capacitors that will correct the indicated number of lamps to 90% power factor or better. Data for 60 cycles*				
		1	2	3	4	5
15-watt T-8	118	A	C	BB	D	CC
20-watt T-12	118	A	C	D	CC	E
30-watt T-8	118	C	D	E	DD	DD
40-watt T-12	118	C	D	E	DD	DE
30-watt T-8	208}	A	AA	AA	D	D
40-watt T-12	236}	E	CE	BEE	EEE	EEEE
65-watt T-17	118	E	CE	BEE	EEE	EEEE

* Letters indicate Class FL capacitors to be used. Two letters indicate two capacitors connected in parallel.

volts or multipliers of $\sqrt{3}$ or two times these values. Figure 105 shows typical electrical and luminous characteristics for tulamp fluorescent ballast and lamp circuits such as are shown in Figs. 95, 96, 97, or 98.

At several points tulamp auxiliaries have been mentioned without further discussion. Actually the tulamp auxiliary with power-factor correction accomplishes two results. Since the single-lamp unit produces a certain degree of flicker, even at

TABLE 14.—MAZDA F LAMPS: DIMENSIONS AND ELECTRICAL DATA

Lamp watts ^a	6		8	14	15	20	30	40	65	100
	Nominal length, in.....	9	12	18	24	36	48	60	72	84
Diameter, in.....	5/8	5/8	1 1/2	1 1/2	1	1 1/2	2 1/8	2 1/8	2 1/8	2 1/8
Bulb.....	T-5	T-5	T-12	T-12	T-8	T-12	T-8	T-12	T-17	T-17
Approximate lamp amperes.....	0.15	0.18	0.37	0.30	0.34	0.41	0.35	0.41	1.35	1.45
Approximate lamp volts.....	45	54	41	56	103	108	103	108	50	72
Circuit voltages.....	110-125	110-125	105-125 ^b	110-125	110-125	110-125	199-216, 199-216	199-216, 199-216	110-125	110-125
Rated average life, hr. ^c	750	750	1500	2500	2500	2500	220-250, 220-250	220-250, 220-250	2000	2000
List price, white or day.....	\$1.00	\$1.25	\$1.05	\$0.85 ^d	\$1.10 ^d	\$1.10 ^d	\$1.10 ^d	\$1.60 ^e	\$2.75	\$3.50

^a Add auxiliary watts for total.

^b Voltage range for two-in-series operation in which a specially designed filament lamp (60 volts, 1/2 amp., S-11 outside-white bulb, intermediate-screw base—list price 45 cents) is used as a resistance ballast. Total wattage of two lamps and ballast is 45 on alternating current, 38 on direct current.

^c Under specified test conditions.

^d Soft white, blue, green or pink at 10 cents list additional. Red or gold at 20 cents list additional.

^e Soft white at 10 cents list additional.

RF Lamp.—Another fluorescent light source is the 85-watt RF lamp, which operates from specially designed auxiliary equipment. RF lamps are 58 in. long, 1 1/4 in. in diameter and have special bases which do not fit ordinary fluorescent lamp holders. The lamps have an average rated life of 3000 hr. and produce 4000 lumens initially. The auxiliary consumes about 15 watts per lamp. The list price is \$4.25 each.

60 cycles, it is desirable to operate adjacent lamps so that the peaks of the instantaneous luminous output curves will not occur simultaneously. This may be accomplished by changing the current phasing with respect to a common voltage supply.

TABLE 15.—LUMEN RATINGS OF MAZDA F LAMPS*

Lamp watts	6	8	14	15	20	30	40	65	100
White.....	180	300	460	615 (41)	900 (45)	1450 (49)	2100 (52)	2100	4200 (42)
Daylight.....	155	250	370	495 (33)	730 (36.5)	1200 (40)	1700 (42)	1800	3350 (33.5)
Soft white.....	325	435	640	1050	1500		
Blue.....	315	460	780			
Green.....	900	1300	2250			
Pink.....	300	440	750			
Gold.....	375	540	930			
Red.....	45	60	120			

* Lumen output and efficiency ratings apply at the end of 100 hr. of operation. The efficiency of daylight and white Mazda F lamps at 70 per cent of rated life is about 85 per cent of initial rating. Figures in parenthesis indicate lamp lumens per watt.

TABLE 16.—MAXIMUM BRIGHTNESS IN CANDLES PER SQUARE INCH FOR MAZDA F LAMPS

Lamp watts	6	8	14	15	20	30	40	65	100
White.....	5.42	5.40	2.88	4.76	3.65	5.48	3.87	3.38	4.82
Daylight.....	4.65	4.49	2.32	3.87	2.99	4.54	3.10	2.90	3.87
Soft white.....	2.04	3.43	2.65	3.98	2.77		
Blue.....	2.49	1.88	2.99			
Green.....	7.08	5.31	8.63			
Pink.....	2.32	1.77	2.88			
Gold.....	3.65	2.21	3.54			
Red.....	0.35	0.24	0.46			

A fluorescent lamp will operate with pure capacitive ballast, but the results are entirely unsatisfactory. The current that results is a heavy surge peak which flows only until the condenser is charged and then remains zero for approximately $\frac{1}{2}$ cycle. At that time the condenser is charged at opposite polarity and the cycle is repeated. These heavy surges of current are very destructive to the electron emissive material of the cathodes; and furthermore, the current flows for such short time intervals that the flicker is tremendous.

Instead a series circuit of capacitance and inductance is used with one lamp. The circuit is predominantly capacitive and hence draws a leading current. The current wave form is very good with the capacitance adjusted so that the resonant frequency is about 90 cycles for a 60-cycle supply. This circuit is then paralleled with an inductively ballasted lamp, and the combination is known as the *tulamp auxiliary*. The lamps operate at different current phasing, and the power factor of the combination is 90 per cent or higher. With the tulamp ballasts

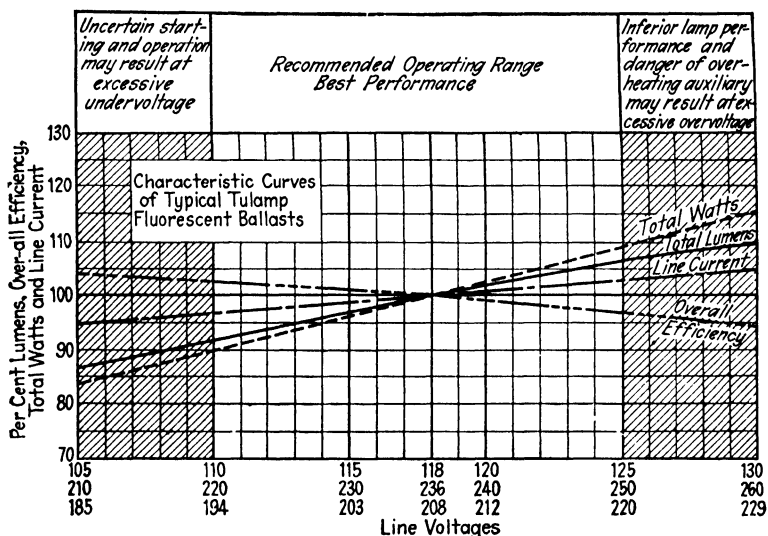

FIG. 105.—Characteristic curves of typical tulamp fluorescent ballasts.

for the smaller lamps a starting compensator is required in series with the leading circuit starting switch to alter momentarily the constant-current characteristic of the leading circuit so the lamp current will rise sufficiently to permit proper electrode heating. Like the starter, it consumes power only on lamp starting, since it is directly in the starter circuit as is shown in Fig. 95 or 96.

The useful lamp life of fluorescent lamps varies with individual lamps as is true of incandescent lamps. Tests on lamps require considerable time for completion, and these tests upon all styles of fluorescent lamps now manufactured are not complete. However, the daylight lamp has been studied rather fully, and the

curve of Fig. 106 gives the maintained lumens as a function of life for this lamp. Rated "initial" outputs of fluorescent lamps are based upon conditions at 100 hr., since the initial darkening

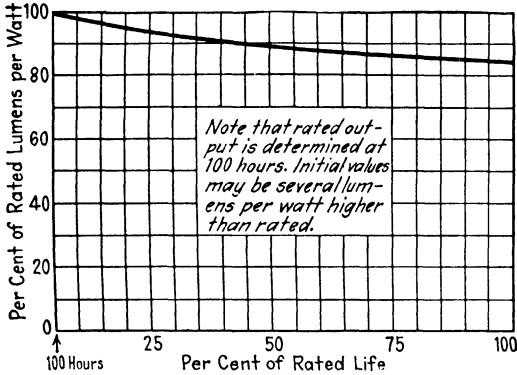

FIG. 106.—Fluorescent lamp lumen maintenance.

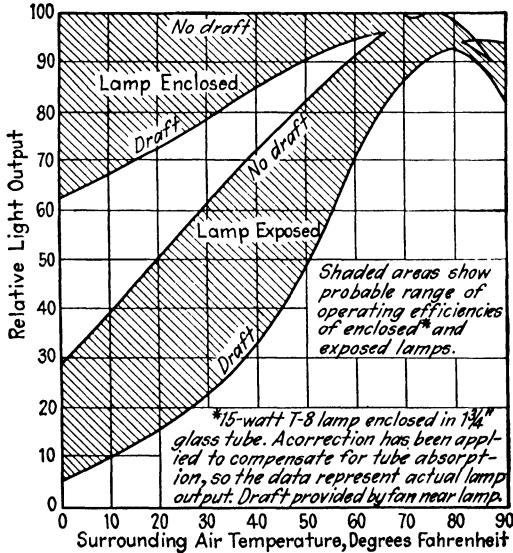

FIG. 107.—Relative light output of a 15-watt fluorescent lamp as affected by air temperature, air movement, and enclosures.

is rather large. Consequently the true initial lumens would mean very little.

Frequent starting of lamps evaporates an undue amount of the active electrode material, and consequently the life of the

lamp is shortened. Rated laboratory life is based upon switching each 3 hr. of burning.

Fluorescent lamps are greatly affected by air currents and temperature conditions in the immediate vicinity of the lamp bulb, as is evidenced by Fig. 107. This chart is for a 15-watt T-8 lamp with and without a $1\frac{3}{4}$ -in. glass tube. In general the lamps operate at their highest efficacy at normal room temperatures of 70 to 80°F. At lower air temperatures, especially when violent air movement is present, the luminous output is tremendously reduced. Cognizance of this fact must be considered in applying fluorescent lamps to air-conditioned rooms. The adverse effect of low surrounding temperatures and air movement can be offset to a great extent by enclosing the lamps.

Problems

1.9. An illumination survey of a room reveals an average illumination of 11.7 ft.-candles. The lamp sources of the room are 300-watt incandescent lamps. A measure of the voltages at the sockets with all lamps on yields an average voltage at all sockets of 107.8 volts. The lamps are rated at 115 volts. Had the lamps been operated at rated voltage, what would have been the average illumination? Are any assumptions necessary, and if so can they be justified?

2.9. An electric customer complains to the power company that his lamps are burning out too rapidly. A check reveals that the voltage at the socket is 119 volts. If the customer uses five 60-watt, A-19 inside-frosted lamps rated at 115 volts an average of 3 hr. per day, how often should he replace a lamp, assuming that there is no mechanical breakage? If the energy rate is 4 cents per kilowatt-hour, what should be his average monthly electric bill for the five lamps? What voltage would result in the most economical light production considering a labor cost of replacement equal to the price of the lamp?

3.9. If five 60-watt A-19 lamps can be replaced by three 100-watt lamps, what percentage increase in luminous flux will result at rated voltage?

4.9. A 230-volt power supply is available for lighting service. A choice is to be made as whether to use one clear 300-watt, 230-volt lamp in a fixture that costs \$10.30 or two clear 150-watt, 115-volt lamps in series in a fixture that costs \$17.50. If the lighting service is to be used for 500 hr. per year and the total fixed charges on the fixture are 20 per cent annually, which is the most economical way to produce one million lumen-hours of light if energy costs 5 cents per kilowatt-hour.

5.9. Will a 15-watt daylight fluorescent lumiline lamp produce one million lumen-hours of light more economically than a 40-watt, A-19 inside-frosted incandescent lamp? (The two lamps have nearly the same luminous output.) Consider the power loss in the auxiliary of the fluorescent lamp. Neglect cost of all "permanent" equipment such as fixtures, auxiliary con-

trols, etc., but consider the cost of the lamps. Both are operated at their rated conditions. Energy cost is 5 cents per kilowatt-hour.

REFERENCES

- Westinghouse High Intensity Mercury Vapor Lamps, Commercial Engineering Department, Westinghouse Lamp Company.
- J. A. St. Louis, Characteristics of 400-watt and 250-watt Type H Mercury Vapor Lamps, *Trans. Illum. Eng. Soc. (N.Y.)*, **31**, 1936, pp. 583-597.
- P. Moon, "The Scientific Basis of Illuminating Engineering," McGraw-Hill Book Company, Inc., New York, 1936.
- Incandescent Electric Lamps, *U.S. Tariff Comm., Rept.* 133, Second Series, 1939.
- λ. B. Oday and R. F. Cissell, Fluorescent Lamps and Their Applications, *Trans. Illum. Eng. Soc. (N.Y.)*, **34**, 1939, pp. 1165-1188.
- J. W. Marden, N. C. Beese, and G. Meister, High Wattage Mercury Arcs, *Trans. Illum. Eng. Soc. (N.Y.)*, **35**, 1940, pp. 458-462.
- R. F. Hays and D. S. Gustin, Alternating Current Circuits for Fluorescent Lamps, *Trans. Illum. Eng. Soc. (N.Y.)*, **35**, 1940, pp. 939-948.
- "Engineering Data on Fluorescent Lamps," General Electric Company, Booklet B, October, 1940.
- E. B. Noel, Radiation from High Pressure Mercury Arcs, *Trans. Illum. Eng. Soc. (N.Y.)*, **36**, 1941, pp. 243-256.
- Standard Price Schedule, Large Mazda Lamps and Type D Lamps, General Electric Company, March, 1941.
- "Fluorescent Mazda Lamps and Auxiliary Equipments," Folder A, General Electric Company, April, 1941.

CHAPTER 10

ILLUMINATION STANDARDS

<i>Term</i>	<i>Definition</i>
Law	A statement of an order or relation of phenomena invariable under the given conditions.
Standard	That which is established as a rule for measuring or as a model or example.
Visual size	The angle subtended at the eye by an object or detail.
Brightness contrast	The difference in brightness of two adjacent areas expressed as a fraction based generally upon the background brightness.

59. General.—In establishing recommendations of illumination for particular usages, the distinction between standards and laws should be discerned very critically. A law is a statement of an order or relation of phenomena invariable under the given conditions. A standard is more easily defined by implication through what it is not rather than through what it is. A standard is not a law.

Standards of illumination can be only a decision as to an economic balance between equipment available and its investment and operating costs on one hand and rather intangible personal effects upon the other. There is no equation known into which these many variables can be substituted and a recommended standard obtained that will be valid for all individuals performing even the same visual task.

It is generally conceded that seeing involves at least five objective relationships—objective at least in the sense in which some of them have been dealt with in this text. These are (1) the visual size of the object or certain critical details of it, (2) the brightness of the object or these details, (3) the brightness contrast between the object and the adjacent field, (4) the brightness or brightness pattern of the remainder of the visual field, and (5) the time available for seeing. In addition to these objective factors are the subjective variables of individual observers such as the person's visual ability and his intelligence, experience, reaction time, concentration, distraction, and fatigue.

60. Luckiesh-Moss Visibility Meter.—One particular instrument has been devised which has helped tremendously in establishing the relative visibility of various tasks as determined through the objective variables mentioned above. This instrument is the Luckiesh-Moss visibility meter.

The meter consists of two filters with precise gradients of transmission which may be rotated simultaneously in front of the eyes while looking at an object or while performing a visual task.

The relative foot-candle scale of the instrument is based upon the ability of a person possessing a normal sense of sight to distinguish through the instrument, when set at a reading of 10, the critical details of 8 point Bodoni Book type well printed upon a good grade of white nonglossy paper with black ink when the task is illuminated by 10 ft.-candles and the surrounding brightness and brightness pattern are reasonable with respect to the brightness of the background of the task.

The critical details (*i.e.*, the space in the letter *c* which distinguishes it from *o*, etc.) of such size type subtend a visual angle of 3.64 min. when viewed at 14 in. This is the basis for fixing *one* point on the relative visibility scale. When the relative foot-candle scale is set at 10 on the instrument, the relative visibility scale reads 3.64.

If some task other than the standard task of 8 point Bodoni Book type is illuminated to 10 ft.-candles and observed through the instrument, the reading of the relative visibility scale for the normal individual will be the visual angle of the critical detail of the task expressed in minutes. Thus a task printed in 4 point Bodoni Book type upon identical paper with identical ink and with identical surroundings should require a setting on the relative visibility scale of 1.60 for the normal individual inasmuch as the critical details of such type subtend an angle of 1.60 min. at 14 in. Thus an absolute meaning of the scale of relative visibility is established.

If, however, instead of the instrument filters being adjusted to achieve the threshold visibility, the illumination upon the task were increased, such illumination for the normal individual would be 175 ft.-candles for the 4 point Bodoni Book type. Thus it is logical that the relative foot-candle scale read 175 when the relative visibility scale is 1.60. Other points on the relative

foot-candle scale have corresponding meanings. Consequently the effect of illumination upon the visual task for a normal individual is fixed on the relative foot-candle scale. Once these scales have been established, they can be used to express relative visibilities and relative foot-candles needed upon tasks for which the critical details may be so involved as to preclude specification as to visual angle.

If it is conceded that the relative threshold visibilities are linear with respect to the relative visibilities in the normal range of use, and further if the 10 ft.-candles upon a visual task having critical details subtending a visual angle of 3.64 deg. is logically taken as the standard, then the relative foot-candle scale of the instrument can be used as a scale of recommended foot-candles for all manner of tasks measured, if the illumination upon the task during the test is 10 ft.-candles. The scale that has been referred to here as the relative foot-candle scale is labeled "recommended foot-candles" on the instrument.

61. Recommended Illumination Standards.—Whether or not the two premises mentioned above can be justified may be argued. That threshold visibilities are an exact criterion for visibilities in the normal range of use is an extremely difficult fact to establish quantitatively. Direct measurements on ease of seeing (as compared to just seeing) are in general not possible. If they were, there would be no point in using a threshold-visibility meter such as the Luckiesh-Moss meter. Likewise whether or not 10 ft.-candles is a logical reference point for the 8 point Bodoni Book type may also be argued.

Consequently the establishment of standards eventually depends upon what the public can be sold in the way of adequate levels of illumination, to the point where the financial limitations balance any increased advantages in further reductions of energy used by individuals in performing visual tasks under the lighting systems thus established. That such standards should not be static is obvious to the point of some "ideal maximum." Advancements in methods of light production, reduction in electrical-energy rates, mass-production methods applied to luminaire manufacture, improvements in the control of light, and many other factors have constantly been changing—some rather steadily, others by occasional changes that we like to call revolutionary rather than evolutionary. The discovery of wicks

as used in early flame lamps, the use of mantels in gaseous vapor lamps, and the development of all our incandescent and luminescent lamps of today have certainly been factors influencing changes in standards.

TABLE 17.—RECOMMENDED STANDARDS OF ILLUMINATION: STORES*
(In foot-candles)

For store interiors, high levels of illumination are desirable to facilitate seeing; yet other aspects, such as making the interior attractive to create an atmosphere that will stimulate sales, are particularly valuable to the store owner. In lighting, the storekeeper has a versatile and flexible medium for advertising and decoration. Hence a factor in the well-lighted store is the exercising of ingenuity and artistic ability in connection with general lighting along with special lighting for prominent merchandise displays. Briefly, light attracts prospective customers, which makes its use a factor of importance in meeting competition.

Location	General interior lighting	Showcase	Show window	Lighting to reduce daylight window reflections	Special displays inside store		
					Light colored	Medium colored	Dark colored
Large cities:							
Brightly lighted district . . .	20	50-100	200	200-1000	30-50	50-100	100 or more
Secondary business locations	20	50-100	100	200-1000	30-50	50-100	100 or more
Neighborhood stores	15	50-100	50	200-1000	30-50	50-100	100 or more
Medium cities:							
Brightly lighted districts . .	20	50-100	100	200-1000	30-50	50-100	100 or more
Neighborhood stores	15	50-100	50	200-1000	30-50	50-100	100 or more
Small cities and towns	15	50-100	50	200-1000	30-50	50-100	100 or more

* From "Illumination Design Data," General Electric Company, October, 1936.

It is the contention of Luckiesh and Moss, based upon researches in fatigue, nervous muscular tension, and other similar effects, that measurable advantages can be determined for illumination levels ranging much above those listed in Tables 17, 18, and 19. The fact that installations of lighting systems based upon these recommendations are being made and that the owners of such installations feel in general that because of them they are gaining advantages in reduction of errors, better labor conditions, and employee morale is the best proof that our standards are not too high for an economic balance. As has always been true, the illumination level is only one phase of the task of seeing. Whence

comes the light is just as important as what is its density. Perhaps we have now reached a point in respect to methods of light production, electrical-energy rates, and the physical manufacturing methods of luminaires where improvements in the control of light should be the next advancement lest the illumination levels of lighting systems advance out of proportion to the quality aspects of those systems.

TABLE 18.—RECOMMENDED STANDARDS OF ILLUMINATION: COMMERCIAL AND PUBLIC INTERIORS^a

In offices, drafting rooms, school classrooms, and other interiors in which the visual tasks are difficult and prolonged, it is of prime importance to consider lighting not for barely seeing but for easy seeing. Not only is high-level general illumination required, but supplementary lighting is often necessary on desks, business machines, and blackboards. Such local lighting must be chosen with careful attention to shading, diffusion, shadows, and reflected glare.

	Foot-candles
Armories—drill sheds and exhibition halls. . .	10
Art galleries:	
General	5
On paintings	Supplementary
Auditoriums	5
Automobile showrooms	20
Banks:	
Lobby	10
Cages	Supplementary
Offices	20
Barber shops and beauty parlors	20
Churches:	
Auditoriums	5
Sunday-school rooms	10
Pulpit or rostrum	15
Club and lodge rooms:	
Lounge and reading rooms	20
Auditoriums	5
Courtrooms	10
Dance halls	5
Drafting rooms	30
Fire-engine houses:	
When alarm is turned in	10
At other times	2
Garages, automobile:	
Storage, dead	2
Storage, live	10
Repair and washing department	Supplementary

^a From "Illumination Design Data," General Electric Company, October, 1936.

TABLE 18.—RECOMMENDED STANDARDS OF ILLUMINATION: COMMERCIAL AND PUBLIC INTERIORS*.—(Continued)

	Foot-candles
Hangars, airplane.....	10
Repair department.....	Supplementary
Hospitals:	
✓Corridors.....	2
✓Laboratories.....	20
Lobby and reception room.....	5
✓Operating room.....	20
Operating table.....	Supplementary
Private rooms and wards (with local illumination).....	20
Hotels:	
Lobby.....	10
Dining room.....	5
✓Kitchen.....	10
Guest rooms.....	10
Corridors.....	2
Writing rooms.....	20
Libraries:	
Reading room.....	20
Stack room.....	10
Motion-picture theaters:	
During intermission.....	5
During pictures.....	0.1
Museums:	
General.....	10
Special displays.....	Supplementary
Night clubs and bars.....	5
Office buildings:	
Bookkeeping, typing, and accounting.....	30
Business machines, power driven (transcribing and tabulating)—calculators, key punch, bookkeeping.....	Supplementary
Conference room:	
General meetings.....	10
Office activities (<i>see</i> Desk Work, below).	
Corridors and stairways.....	5
Desk Work:	
Intermittent reading and writing.....	20
Prolonged close work, computing, studying, designing, etc.....	30-50
Reading blueprints and plans.....	30
Drafting:	
Prolonged close work—art drafting and designing in detail.....	30-50
Rough drawing and sketching.....	30

* From "Illumination Design Data," General Electric Company, October, 1936.

TABLE 18.—RECOMMENDED STANDARDS OF ILLUMINATION: COMMERCIAL AND PUBLIC INTERIORS^a.—(Continued)

	Foot-candles
Filing and index references.....	20
Mail sorting.....	20
Reception rooms.....	10
Stenographic work:	
Prolonged reading shorthand notes.....	30-50
Vault.....	10
Post offices:	
Lobby.....	10
Sorting, mailing, etc.....	20
Storage.....	10
Offices, private and general.....	20
File room and vault.....	10
Corridors and stairways.....	2
Professional offices:	
✓ Waiting rooms.....	10
Consultation rooms.....	20
Operating offices.....	20
Dental chairs.....	Supplementary
Restaurants, lunchrooms, and cafeterias:	
Dining area.....	10
Food displays.....	Supplementary
Schools:	
✓ Auditoriums.....	10
Classrooms, library, offices.....	20
Corridors and stairways.....	5
Drawing room.....	30-50
✓ Gymnasium (basketball).....	20
Laboratories.....	15
Manual training.....	20
Sewing room.....	Supplementary
Sight-saving classes.....	30-50
Study rooms—desks and blackboards.....	20
Service Space:	
Corridors.....	5
Elevators, freight and passenger.....	10
Halls and stairways.....	5
Lobby.....	10
Storage.....	5
Toilets and washrooms.....	5
Telephone exchanges:	
Operating rooms.....	10
Terminal rooms.....	15
Cable vaults.....	5
Theaters:	
Auditoriums.....	5

^a From "Illumination Design Data," General Electric Company, October, 1936.

TABLE 18.—RECOMMENDED STANDARDS OF ILLUMINATION: COMMERCIAL AND PUBLIC INTERIORS^a.—(Continued)

	Foot-candles
Foyer.....	10
Lobby.....	15
Transportation:	
Cars:	
Baggage, day coach, dining, pullman....	15
Mail—Bag racks and letter cases.....	20
Storage.....	5
Street railway, trolley, bus, subway....	15
Motor bus.....	10
Depots:	
Waiting rooms.....	10
Ticket offices, general.....	10
Ticket rack and counters.....	Supplementary
Rest rooms, smoking rooms.....	10
Baggage-checking office.....	15
Storage.....	5
Concourse.....	5
Platforms.....	2

^a From "Illumination Design Data," General Electric Company, October, 1936.

TABLE 19.—RECOMMENDED STANDARDS OF ILLUMINATION: INDUSTRIAL INTERIORS^a

Factory workers are charged with a responsibility for maintaining certain standards of speed, accuracy, and perfection. Inability to see quickly and accurately is the cause of slower production, errors, accidents. Under ordinary lighting many circumstances such as high-speed production, distracting surroundings, and fatigue may actually reduce seeing conditions close to or even below threshold where neither certainty nor accuracy of seeing is possible. This tendency is definitely counteracted by higher standards of lighting, and recommended levels of illumination must provide an adequate safety factor in order to maintain visibility well above threshold values for critical tasks and to provide a sufficient margin so that ordinary routine tasks may be accomplished with greater ease and less ocular fatigue.

Critical inspection demands a high standard of lighting, both in quantity of light and quality of lighting. It is uneconomical from the standpoint of loss of time and material if processes must proceed to the point of final inspection before flaws and defects are apprehended, particularly if, by the same adequate lighting on the work, the worker himself might have avoided these faults.

	Foot-candles
Aisles, stairways, passageways.....	2
Assembly:	
Rough.....	10
Medium.....	20
Fine.....	Supplementary

^a From "Illumination Design Data," General Electric Company, October, 1936.

TABLE 19.—RECOMMENDED STANDARDS OF ILLUMINATION: INDUSTRIAL INTERIORS^a.—(Continued)

	Foot-candles
Automobile manufacturing:	
Assembly line.....	Supplementary
Frame assembly.....	15
Body manufacturing:	
Assembly.....	20
Finishing and inspecting.....	Supplementary
Bakeries.....	20
Bookbinding:	
Folding, assembling, pasting, etc.....	10
Cutting, punching, stitching.....	20
Embossing.....	20
Breweries:	
Brew house.....	5
Boiling, keg washing, filling.....	10
Bottling.....	15
Candy making.....	20
Canning and preserving.....	20
Chemical works:	
Hand furnaces, boiling tanks, stationary driers, stationary and gravity crystallizers.....	5
Mechanical furnaces, generators and stills, Mechanical driers, Evaporators, Filtration, Mechanical crystallizers, bleaching	10
Tanks for cooking, extractors, percolators, nitrators, electrolytic cells.....	15
Clay products and cements:	
Grinding, filter presses, kiln rooms.....	5
Molding, pressing, cleaning, trimming.....	10
Enameling.....	15
Color and glazing.....	20
Cloth products:	
Cutting, inspecting, sewing:	
Light goods.....	20
Dark goods.....	Supplementary
Pressing, cloth treating (oilcloth, etc.):	
Light goods.....	10
Dark goods.....	20
Coal breaking and washing, screening.....	5
Construction, indoor general.....	10
Dairy products.....	20
Elevator, freight and passenger.....	10
Engraving.....	Supplementary
Forge shops and welding.....	10

^a From "Illumination Design Data," General Electric Company, October, 1936.

TABLE 19.—RECOMMENDED STANDARDS OF ILLUMINATION: INDUSTRIAL INTERIORS^a.—(Continued)

	Foot-candles
Foundries:	
Charging floor, tumbling, cleaning, pouring, shaking out.....	5
Rough molding and core making.....	10
Fine molding and core making.....	20
Garages, automobiles:	
Storage, live.....	10
Storage, dead.....	2
Repair department and washing.....	Supplementary
Glassworks:	
Mix and furnace rooms, pressing and Lehr glass-blowing machines.....	10
Grinding, cutting glass to size, silvering... ..	20
Fine grinding, polishing, beveling, etching, decorating.....	Supplementary
Inspection.....	Supplementary
Glove manufacturing:	
Light goods:	
Cutting, pressing, knitting, sorting.....	20
Stitching, trimming, inspecting.....	20
Dark goods:	
Cutting, pressing, knitting, sorting.....	20
Stitching, trimming, inspecting.....	Supplementary
Hangars, airplane:	
Storage, live.....	10
Repair departments.....	Supplementary
Hat manufacturing:	
Dyeing, stiffening, braiding, cleaning, refin- ing:	
Light.....	10
Dark.....	20
Forming, sizing, pouncing, flanging, finish- ing, ironing:	
Light.....	15
Dark.....	30
Sewing:	
Light.....	20
Dark.....	Supplementary
Ice making, engine and compressor room....	10
Inspection:	
Rough.....	10
Medium.....	20
Fine.....	Supplementary
Jewelry and watch manufacturing.....	Supplementary
Laundries and dry cleaning.....	20

^a From "Illumination Design Data," General Electric Company, October, 1936.

TABLE 19.—RECOMMENDED STANDARDS OF ILLUMINATION: INDUSTRIAL INTERIORS^a.—(Continued)

	Foot-candles
Leather manufacturing:	
Vats.....	5
Cleaning, tanning, stretching.....	10
Cutting, fleshing, stuffing.....	15
Finishing and scarfing.....	20
Leather working:	
Pressing, winding, glazing:	
Light.....	10
Dark.....	20
Grading, matching, cutting, scarfing, sewing:	
Light.....	20
Dark.....	Supplementary
Locker rooms.....	5
Machine shops:	
Rough bench and machine work.....	10
Medium bench and machine work, ordinary automatic machines, rough grinding, medium buffing and polishing.....	20
Fine bench and machine work, fine automatic machines, medium grinding, fine buffing and polishing.....	Supplementary
Meat packing:	
Slaughtering.....	10
Cleaning, cutting, cooking, grinding, canning, packing.....	20
Milling—grain foods:	
Cleaning, grinding, rolling.....	10
Baking or roasting.....	20
Flour grading.....	30
Offices, private and general:	
No close work.....	10
Close work.....	20
Drafting rooms.....	30
Packing and boxing.....	10
Paint manufacturing.....	10
Paint shops:	
Dipping, spraying, firing, rubbing, ordinary hand painting and finishing.....	20
Fine hand painting and finishing.....	Supplementary
Extra fine hand painting and finishing (automobile bodies, piano cases, etc.)...	Supplementary
Paper-box manufacturing:	
Light.....	10

^a From "Illumination Design Data," General Electric Company, October, 1936.

TABLE 19.—RECOMMENDED STANDARDS OF ILLUMINATION: INDUSTRIAL INTERIORS^a.—(Continued)

	Foot-candles
Dark.....	20
Storage of stock.....	5
Paper manufacturing:	
Beaters, grinding, calendering.....	10
Finishing, cutting, trimming.....	20
Plating.....	10
Polishing and burnishing.....	15
Power plants, engine rooms, boilers:	
Boilers, coal and ash handling, storage-battery rooms.....	5
Auxiliary equipment, oil switches and transformers.....	10
Switchboards, engines, generators, blowers, compressors.....	15
Printing industries:	
Matrixing and casting.....	10
Miscellaneous machines.....	15
Presses and electrotyping.....	20
Lithographing.....	Supplementary
Linotype, monotype, typesetting, imposing stone, engraving.....	Supplementary
Proofreading.....	Supplementary
Receiving and shipping.....	10
Rubber manufacturing and products:	
Calenders, compounding mills, fabric preparation, stock cutting, tubing machines, solid-tire operations, mechanical-goods building, vulcanizing.....	10
Bead building, pneumatic-tire building and finishing, inner-tube operation, mechanical-goods trimming, treading.....	20
Sheet-metal works:	
Miscellaneous machines, ordinary bench work.....	15
Punches, presses, shears, stamps, welders, spinning, medium bench work.....	20
Tin-plate inspection.....	Supplementary
Shoe manufacturing:	
Hand turning, miscellaneous bench and machine work.....	10
Inspecting and sorting raw material, cutting and stitching:	
Light.....	20

^a From "Illumination Design Data," General Electric Company, October, 1936.

TABLE 19.—RECOMMENDED STANDARDS OF ILLUMINATION: INDUSTRIAL INTERIORS^a.—(Continued)

	Foot-candles
Dark.....	Supplementary
Lasting and wetting.....	20
Soap manufacturing:	
Kettle houses, cutting, soap chip and powder.....	10
Stamping, trapping and packing, filling and packing soap powder.....	20
Steel and iron mills; bar, sheet, and wire products:	
Soaking pits and reheating furnaces.....	5
Charging and casting floors.....	10
Muck and heavy rolling, shearing, rough by gage, pickling, cleaning.....	10
Plate inspection, chipping.....	Supplementary
Automatic machines, light and cold rolling, wire drawing, shearing, fine by line.....	15
Stone crushing and screening:	
Belt-conveyor tubes, main-line shafting spaces, chute rooms, inside of bins.....	5
Primary breaker room, auxiliary breakers under bins.....	5
Screens.....	10
Storage-battery manufacturing:	
Molding of grids.....	10
Store and stock rooms:	
Rough bulky material.....	2
Medium or fine material requiring care....	10
Structural-steel fabrication.....	10
Sugar grading.....	30
Testing:	
Rough.....	10
Fine.....	20
Extra fine instruments, scales, etc.....	Supplementary
Textile mills:	
Cotton:	
Opening and lapping, carding, drawing, roving, dyeing.....	10
Spooling, spinning, drawing, warping, weaving, quilling, inspecting, knitting, slashing (over beam end).....	20
Silk:	
Winding, throwing, dyeing.....	15

^a From "Illumination Design Data," General Electric Company, October, 1936.

TABLE 19.—RECOMMENDED STANDARDS OF ILLUMINATION: INDUSTRIAL INTERIORS^a.—(Continued)

	Foot-candles
Quilling, warping, weaving, finishing:	
Light goods.....	15
Dark goods.....	30
Woolen:	
Carding, picking, washing, combing.....	10
Twisting, dyeing.....	10
Drawing-in, warping:	
Light goods.....	15
Dark goods.....	30
Weaving:	
Light goods.....	15
Dark goods.....	30
Knitting machines.....	20
Tobacco products:	
Drying, stripping, general.....	10
Grading and sorting.....	Supplementary
Toilets and washrooms.....	5
Upholstering—automobile, coach, furniture..	20
Warehouse.....	5
Woodworking:	
Rough sawing and bench work.....	10
Sizing, planing, rough sanding, medium machine and bench work, gluing, veneering, cooperage.....	20
Fine bench and machine work, fine sanding and finishing.....	30

^a From "Illumination Design Data," General Electric Company, October, 1936.

REFERENCES

- M. Luckiesh and F. K. Moss, "Seeing," The Williams & Wilkins Company, Baltimore, 1931.
- M. Luckiesh and F. K. Moss, Visibility: Its Measurement and Significance in Seeing, *J. Franklin Inst.*, **220**, 1935, p. 431.
- "Illumination Design Data," General Electric Company, October, 1936.
- M. Luckiesh and F. K. Moss, Prescribing Light and Lighting, *Trans. Illum. Eng. Soc. (N.Y.)*, **32**, 1937, p. 19.

CHAPTER 11

DESIGN OF INTERIOR LIGHTING SYSTEMS USING COMMERCIAL LUMINAIRES

<i>Symbol</i>	<i>Term</i>	<i>Definition</i>
	Luminaire	The ensemble of lamps, sockets, and any other parts attached thereto for light control, decoration, or other similar purposes.
C_I	Coefficient of distribution (indirect, horizontal, or direct)	The ratio of the flux received at the working plane to that of the respective component fluxes of the luminaire.
C_{II}		
C_D		
	Room index	A reference number used to classify rooms as to their proportions.
ϕ_I	Indirect, horizontal, and direct component fluxes	An arbitrary separation of the flux emitted by the luminaire according to the "three-curve calculation method."
ϕ_{II}		
ϕ_D		
ϕ_T		
	Total flux	The total flux from each luminaire received at the working plane—arbitrarily considered that which can be utilized.
ϕ_L	Lamp flux	The flux emitted by the lamps of each luminaire.
η	Luminaire efficiency	The ratio of the flux emitted by the luminaire to the total of the lamp(s) flux(es).
K_u	Coefficient of utilization	The ratio of the flux received from each luminaire at the working plane to the flux emitted by the lamp(s) of each luminaire.
M	Maintenance factor	The ratio of the maintained illumination of a lighting system to its initial value.

62. General.—The calculation of the illumination at a point on a surface by the use of the candle-power-distribution curve of a luminaire yields only the illumination produced directly by the luminaire. In an interior room the illumination at a point on the top of a horizontal surface is derived not only directly from the luminaire but also from the ceiling and those side walls above the surface. The ceiling and walls receive luminous flux from the luminaire. Some of this flux is reflected according to the nature of the surface and the spectral characteristics of the incident flux. After one or more reflections, a

portion of this flux may eventually be received on the horizontal surface under consideration. The surface being investigated is generally called the *working plane* and may be a real plane (as the actual surface of a desk) or an imaginary plane at some specified distance above the floor.

A general mathematical formulation of the manner in which the flux is distributed, reflected, and eventually received at the working plane is possible. However, as is often the case in mathematical formulations, the application to any specific case and the solution of that case may become so involved in mathematics of the more advanced type that even though a solution were possible, the process would be so involved as to be beyond the scope of practical engineering usage as we know it today.

Hence the method used at the present time in designing interior lighting systems involving interreflections is an empirical one called the *lumen method*.

63. Work of Harrison and Anderson.—The lumen method of interior lighting design was developed by Ward Harrison and Earl A. Anderson and is reported in the *Transactions of the Illuminating Engineering Society* of 1916 and 1920. Originally the method was called the *three-curve calculation method*.

Certain elements of the original method have very definite advantages, and it is rather unfortunate that the simplification of the method for the use of the layman has resulted in combining some of these elements in such a manner that the design data as they are usually presented¹ apply only to certain luminaires whose distribution curves may fit those listed in the design data.

The first investigations of Harrison and Anderson dealt with rooms in which the floor area was square and whose ceiling height was variable over a considerable range. Later investigations involved the effect of the shape of the room as regards length and width.

Three types of units, whose distribution curves were of quite different form, were used in the investigations. These three component distribution curves (all having a vertical axis of symmetry) were called the *indirect*, *horizontal*, and *direct* types. The direct type was further subdivided under three classifications. Thus, in applying the method to any form of distribution curve, that curve may be broken down into three component

¹ "Illumination Design Data," General Electric Company, October, 1936.

curves, with one of these (the direct) to be classified into one of three subtypes. The details of the application of the method will be discussed in Art. 67.

Illumination surveys were made upon installations of each of the five different types of units considered above. The surveys were made at a working plane of 36 in. above the floor. From the resulting readings the average illumination on this working plane was calculated. This average illumination multiplied by the area of the working plane gave the luminous flux over the area. This flux was, of course, measured in lumens; hence the name of the method.

TABLE 20.—ALLOWABLE SPACING BETWEEN LIGHT SOURCES*

Ceiling height (or height in the clear), ft.	Spacing between outlets for direct or semi-direct systems		Spacing between outside outlets and wall		Approximate area per outlet (at usual spacing), sq. ft.
	Usual, ft.	Maximum (for units at ceiling), ft.	Aisles or storage next to wall	Desks, work benches, etc., against wall, maximum, ft.	
8	7	7½	Usually one-half actual spacing between units	3	50-60
9	8	8		3	60-70
10	9	9		3½	70-85
11	10	10½		3½	85-100
12	10-12	12		3½-4	100-150
13	10-12	13		3½-4½	100-150
14	10-13	15		4-5	100-170
15	10-13	17		4-5	100-170
16	10-13	19		4-6	100-170
18	10-20	21		4-6	100-400
20 and up	18-24	24	5-7	300-500	

* From "Illumination Design Data," General Electric Company, October, 1936.

If the flux received at the working plane is divided by the flux emitted by the luminaire (*not* the flux of the lamp source itself), the ratio can be called the coefficient of distribution for the particular component type of unit and for the particular room under consideration. The addition of the results of the three component calculations yields the ratio of the total flux received at the working plane to that emitted by the luminaire.

64. Spacing and Mounting Height of Luminaires.—The spacing of the luminaires used in the testing was such as to produce reasonably uniform illumination over the working plane. Limits of spacing and mounting height are shown in Tables 20 and 21, respectively.

The spacing relations apply not only to individual luminaires but equally so to the spacing between continuous or extended luminous beam panels, troughs, or sections of coves. There

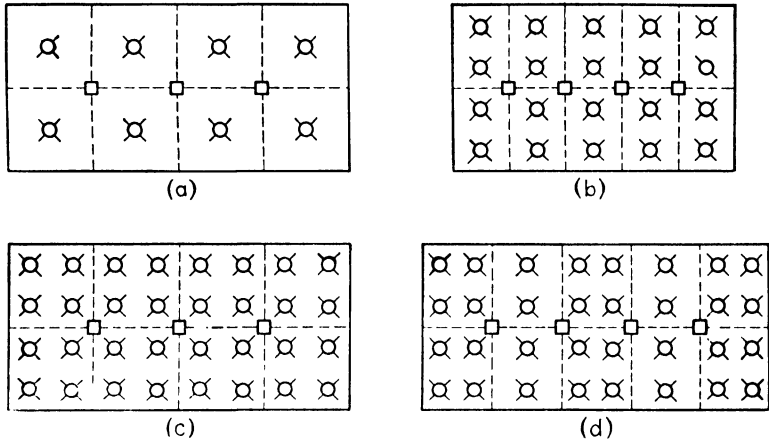

FIG. 108.—Typical layouts. (a) One unit per bay: satisfactory only where the bay size is no greater than the maximum allowable spacing an unusual condition except in high-ceilinged rooms. (b) Two units per bay: usually applicable in narrow bays where the width is less than two-thirds the length. (c) Four units per bay: this is the most common arrangement for the square bay of usual dimensions. (d) Four-two system: equivalent to three units per bay. An alternative to four per bay where spacing allows.

are, however, some exceptions in the case of equipments giving especially concentrated or exceptionally widespread distribution of light.

Concentrating lowered downlights or lens plates provide varying degrees of concentration. The spacing between units to provide uniformity over a general area or lengthwise of a counter or worktable should be regulated by the actual distribution characteristics of the unit. In general, the usual purpose is fulfilled by a spacing about one-third to one-half the values given in the table.

Semi-indirect and indirect systems diffuse the light widely from the ceiling as a secondary source of large area, and the

spacing between units may be about 2 ft. greater than indicated in Table 20.

Alternate mercury and incandescent units in combination systems should provide a fair degree of uniformity with either system used alone and should permit overlapping and blending of the light when used in combination. An alternate staggered layout with the spacing between units not to exceed 0.8 of the mounting height above the floor is recommended.

In order that the spacing of units conform with the architectural design of the room, closer spacings than those indicated in Table 20 may be necessary in certain instances. Several typical layouts are shown in Fig. 108. Other layouts may be desirable where the usefulness of varied arrangements may predominate over appearance.

TABLE 21.—MOUNTING HEIGHT OF LIGHT SOURCES*

Direct and semi-direct lighting units				Semi-indirect and indirect lighting	
Actual spacing between units, ft.	Distance of units from floor, minimum, ft.	Desirable mounting height in industrial interiors	Desirable mounting height in commercial interiors	Actual spacing between units, ft.	Recommended suspension length (top of bowl to ceiling), ft.
7	8	12 ft. above floor	The actual hanging height should be governed largely by general appearance, but particularly in offices and drafting rooms the minimum values shown in the second column should not be violated	7	1 -3
8	8½	if possible—to avoid glare and		8	1 -3
9	9	still be within reach from		9	1 -3
10	10	stepladder for cleaning		10	1½-3
11	10½	Where units are to be mounted		11	2 -3
12	11	much more than 12 ft., it is usually desirable to		12	2 -3
14	12½	mount the units at ceiling or on roof		14	2½-4
16	14	trusses		16	3 -4
18	15			18	3 -4
20	16			20	4 -5
22	18			22	4 -5
24	20			24	4 -6

* From "Illumination Design Data," General Electric Company, October, 1936.

65. Room Index.—The term *room ratio* was originally used by Harrison and Anderson to represent certain ratios of the width of the room to some function of the height from the plane of work to the source of light. This ratio applied directly to square rooms. Various methods were proposed at that time to be used with rectangular rooms.

More recently the term used to specify the shape of the room has been *room index*. The same numerical results were used until recently when some publications have changed the numerical system to a letter system. Such tables as published do not lend themselves to an interpolation of results. Should the dimensions of a particular room chance to fall at an edge of the rather large block of dimensions specified as a particular room index, a certain result is obtained. However, if the room dimensions are changed ever so slightly, another block is entered and a different room index results. Conversely, if the change of room dimensions is made in the opposite direction, an enormous change in dimensions can be made before the room index changes.

Since the same shape of room should always yield the same room index, inconsistencies are prevalent in such tables. For example, assume two rooms *a* and *b*. Let room *a* have the following dimensions: width, 24 ft.; length, 110 ft.; and height, 18 ft. The room index from such a table as discussed gives a room index of *E* for indirect lighting systems. Now let room *b* have dimensions just 1.5 times as large. Since the proportions of the room have not changed, the room index should be the same. However, if the table is entered with a width of 36 ft., length of 165 ft., and height of 27 ft., the room index seems to be *F*. Obviously both results cannot be correct.

If the ratio of the height to width and length to width is plotted for each room index, a rather broad spread of data results because of the block data form of the table. However, with approximately 700 points of data a consistent family of average curves can be obtained. Such a system of curves is plotted in Fig. 109 and again in Fig. 110 for indirect and semi-indirect and direct and semi-direct systems of lighting, respectively. The room index is given as a numeric so that the data can be used later most effectively.

For indirect lighting systems the ceiling is the source of light to the room, and hence the height considered is the actual ceiling

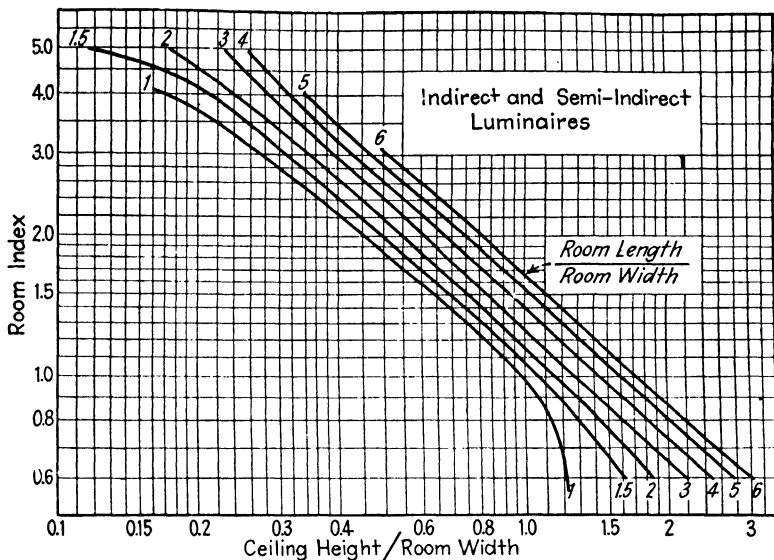

FIG. 109.—Room-index chart for indirectly and semi-indirectly illuminated rooms.

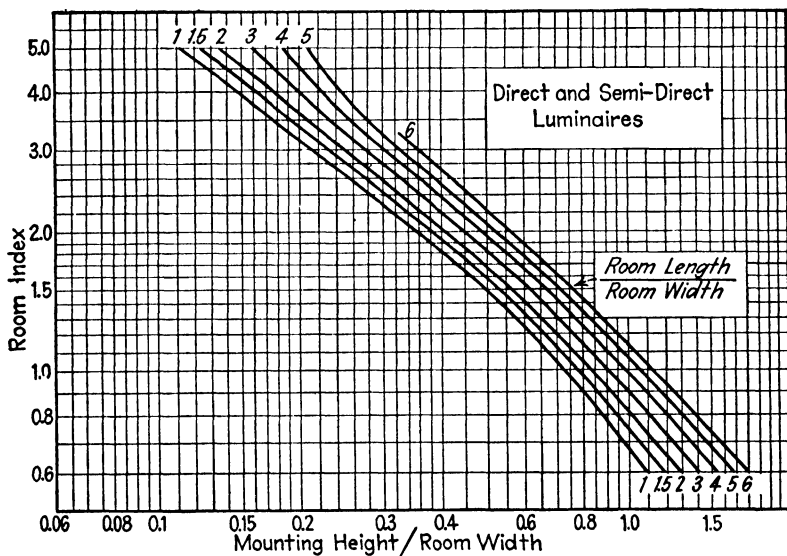

FIG. 110.—Room-index chart for directly and semi-directly illuminated rooms.

height. True, each luminaire used must be suspended at a distance comparable with the distribution of light from the unit; but in so far as wall reflections and absorptions are involved, the full ceiling height is the important item and not the mounting height of the unit.

For direct lighting systems in which the luminous flux is emitted by the luminaire below the horizontal, the ceiling height is immaterial and the mounting height should be the criterion for determining the room index.

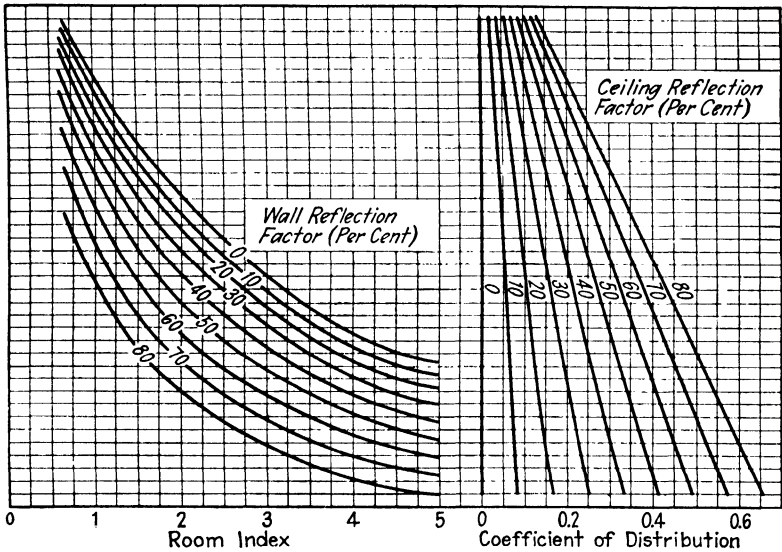

FIG. 111.—Indirect component coefficients of distribution.

Many luminaires are neither completely indirect nor direct in their manner of flux distribution. For those units which emit a majority of their flux above the horizontal, Fig. 109 should be used. For those which emit a majority below the horizontal, Fig. 110 should be used. For luminaires having approximately equal distribution, both charts should be checked and a weighted average used. For example, assume a room having dimensions of 24 ft. width by 110 ft. length by 18 ft. height with units suspended 5 ft. from the ceiling. Thus the ratio of length to width is 4.6, ceiling height to room width 0.75, and mounting height to room width 0.54. Entering the chart of Fig. 109 gives a room index of 1.9, whereas entering

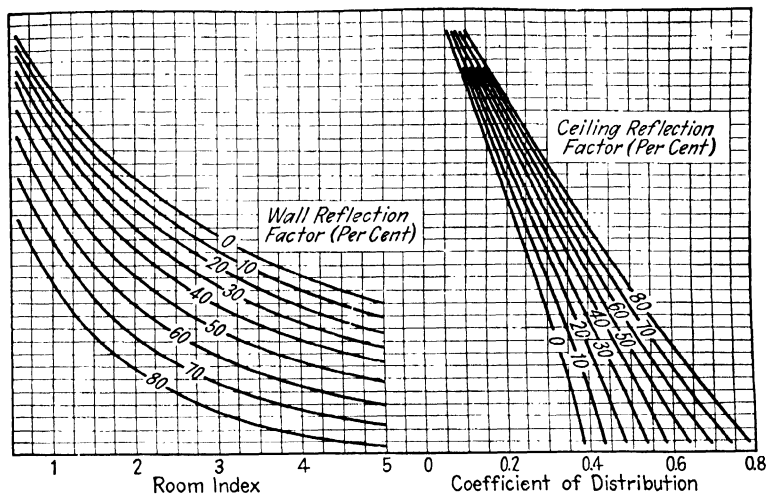

FIG. 112.—Horizontal component coefficients of distribution.

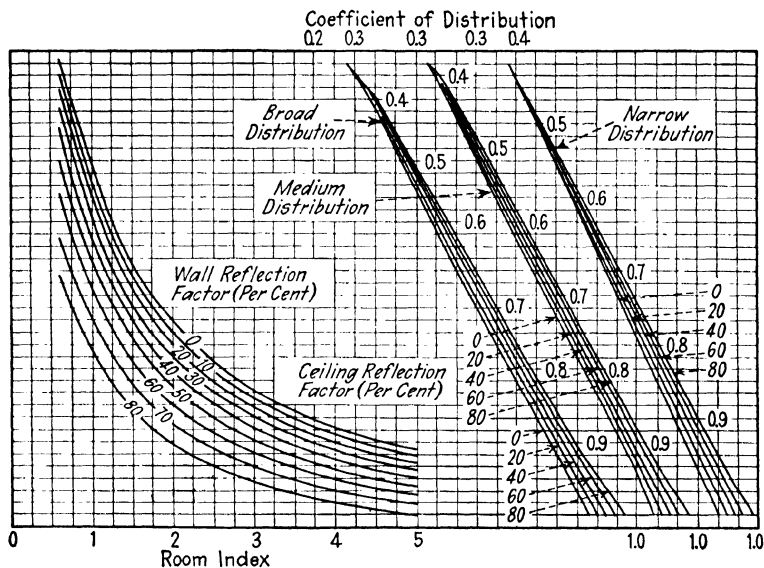

FIG. 113.—Direct component coefficients of distribution.

the chart of Fig. 110 likewise gives 1.9. Rooms with ceiling heights of 10 to 20 ft. with mounting heights of approximately three-fourths the ceiling heights will generally give indexes approximately the same from either chart. However, it is well to check each chart if the classification of the luminaire is doubtful.

66. Coefficients of Distribution.—Harrison and Anderson's results on the five component types of curves discussed previously are tabulated in the *Transactions of the Illuminating Engineering Society*, March, 1920. The variables considered for each component type of luminaire were the room index, ceiling-reflection factor, and wall-reflection factor. The floor-reflection factor for all the tests was 14 per cent. Tests have indicated that the reflection factor of the floor has very little effect upon the coefficients of distribution where the floor-reflection factor is less than 40 per cent. At higher reflection factors, especially if the ceiling and side walls are also very light, the coefficients of distribution may be increased as much as 15 per cent. All results as used today refer to this original floor-reflection factor, generally with no mention of its magnitude.

The data as presented in the transactions occupy eight pages, and many cross interpolations are necessary if data are desired at values between tabulations. Plotting the data in nomographic chart form obviates the necessity of many pages of data and at the same time permits easy interpolation graphically. Figures 111, 112, and 113 represent the data for the three component distribution curves.

An example will illustrate the manner of use. Assume that the room index as determined previously is 1.9, that the average wall-reflection factor is 35 per cent, and that the ceiling-reflection factor is 70 per cent. Entering the chart of Fig. 111 at the room-index scale of 1.9 and carrying this abscissa to an interpolated 35 per cent wall-reflection factor point one arrives at a definite ordinate. Then, carrying this ordinate (which in itself has no meaning) over horizontally to the 70 per cent ceiling-reflection factor curve, one finds this to be directly above the 0.34 abscissa on the coefficient of distribution scale. This gives the coefficient for the indirect component of the distribution curve. In a similar manner the coefficient for the horizontal component is 0.39 and for the direct component either 0.71,

0.74, or 0.76 depending upon whether the direct distribution curve component is broad, medium, or narrow. The definition of these three terms will be considered in Art. 67.

67. Three-curve Calculation Method.—The candle-power distribution curve to be applied in an illumination system must be separated into its three component curves. Consider a luminaire

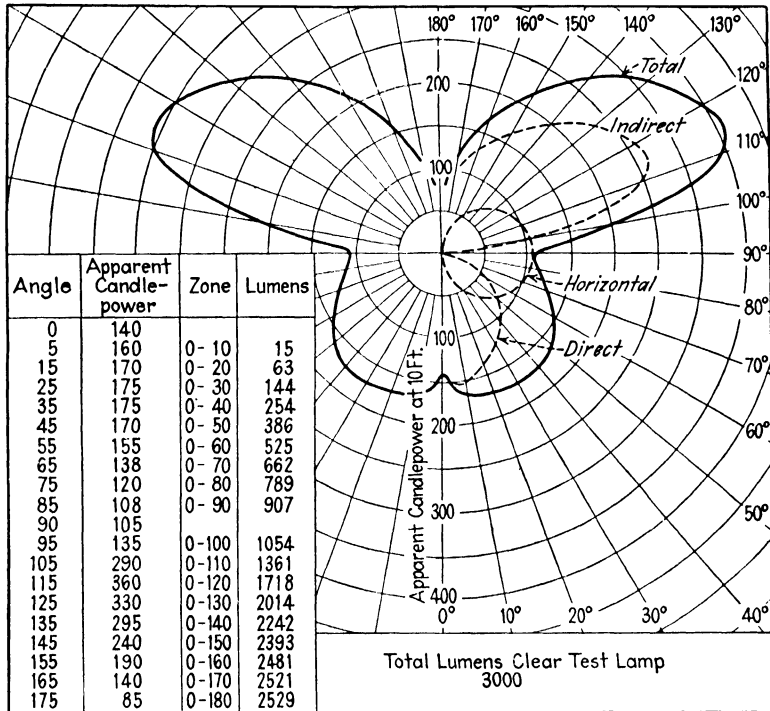

FIG. 114.—Separation of candle-power distribution curve into three component curves.

having a distribution curve such as the solid curve of Fig. 114. The horizontal component is determined first. This component will be made the same magnitude at $\theta = 90$ deg. as the original curve and will be circular in form (since this was the form of curve used in the horizontal-component tests).

The total lumens represented by a circular curve such as the horizontal component of the figure is $\phi_H = \pi^2 I(90 \text{ deg.})$ as can be shown by the methods of Art. 29.

With the horizontal-component curve subtracted, the indirect- and direct-component curves remain as shown.

If $\phi(90^\circ-180^\circ)$ is the flux from the original distribution curve in the zone above the horizontal, then the indirect component flux is

$$\phi_I = \phi(90^\circ-180^\circ) - 4.93I(90^\circ) \quad (102)$$

Likewise the direct component of flux is

$$\phi_D = \phi(0^\circ-90^\circ) - 4.93I(90^\circ) \quad (103)$$

The horizontal component of flux as discussed above is

$$\phi_H = 9.87I(90^\circ) \quad (104)$$

The classification of the direct-component curve into one of the three types of broad, medium, or narrow should be made. The classification is an arbitrary one made upon the percentage of the direct component flux in the $0^\circ-40^\circ$ zone, considering the direct component flux as 100 per cent. The limits of these percentages are taken by Harrison and Anderson as

Broad—35 to 40 per cent (or less than 35 per cent if necessary)

Medium—40 to 45 per cent

Narrow—45 to 50 per cent (or more than 50 per cent if necessary)

These limits will be found to apply to practically all common types of direct-component distribution curves except those with the flux concentrated in very narrow zones such as special projector types. These types are seldom used for general illumination but rather as supplementary sources.

It should be noted that the percentages as indicated above are for the direct-component fluxes (as of dotted curves of Fig. 114) and not for the total fluxes in the respective zones of the complete distribution curve. However, the percentage as considered may be found from the total fluxes from the following relationship.

$$\begin{aligned} &\text{Percentage of direct-component flux in } 0^\circ-40^\circ \text{ zone} \\ &= \frac{\text{total } \phi \text{ in } 0^\circ-40^\circ \text{ zone} - 0.67I(90^\circ)}{\text{total } \phi \text{ in } 0^\circ-90^\circ \text{ zone} - 4.93I(90^\circ)} \quad (105) \end{aligned}$$

If the information upon the distribution of flux is in such form that the total flux in the zone from $\theta = 0^\circ$ to 40° cannot be

determined or even estimated, the medium classification should be used.

Having arrived at the subdivision of the flux of the luminaire into its three classifications from equations (102), (103), and (104) and with ϕ_D further classified as of a broad, medium, or narrow nature, we are ready to set up the flux on the working plane in terms of that of the luminaire through the three charts already considered. Inasmuch as the coefficient of distribution of each component represents the ratio of flux received to that emitted, the total flux received at the working plane from each luminaire is

$$\phi_T = C_I \phi_I + C_H \phi_H + C_D \phi_D \quad (106)$$

where ϕ_T = total flux received at working plane from each luminaire.

C_I = coefficient of distribution as from Fig. 111.

C_H = coefficient of distribution as from Fig. 112.

C_D = coefficient of distribution as from Fig. 113 (for the proper broad, medium, or narrow classification, and ϕ_I , ϕ_H , and ϕ_D are the same as in equations (102), (103), and (104).

The sum of ϕ_I , ϕ_H , and ϕ_D obviously represents the total flux emitted by the luminaire. This flux is not the flux emitted by the lamp, which will always be larger. If the efficiency of the luminaire itself be represented by η , the flux emitted by the lamp will be

$$\phi_L = \frac{\phi_I + \phi_H + \phi_D}{\eta} \quad (107)$$

or

$$\eta = \frac{\phi_I}{\phi_L} + \frac{\phi_H}{\phi_L} + \frac{\phi_D}{\phi_L} \quad (107a)$$

Each of these individual ratios can be considered as a component efficiency, the sum of which is the efficiency of the luminaire. Commercial data on luminaires have not been presented in this fashion, and consequently the concept has little use. However, this manner of presenting commercial data would be extremely useful. Many manufacturers give distribution curves in their engineering literature but often even fail to mention the value of η .

If each of the component efficiencies of the unit is symbolized by η_I , η_H , and η_D , respectively, for the indirect, horizontal, and direct components, then equation (106) may be rewritten as

$$\phi_T = (C_I\eta_I + C_H\eta_H + C_D\eta_D)\phi_L \quad (108)$$

or

$$K_u = \frac{\phi_T}{\phi_L} = C_I\eta_I + C_H\eta_H + C_D\eta_D \quad (109)$$

where K_u is the coefficient of utilization of the luminaire as a whole applied to the particular classification of room. The indirect or direct components of this coefficient may be negative, but the coefficient itself is always positive.

An application of the foregoing method to an installation of the luminaire represented by the distribution curve of Fig. 114 will be useful in clarifying the method.

The horizontal-component flux for this luminaire will be

$$\begin{aligned} \phi_H &= 9.87I(90^\circ) = 9.87 \times 105 \\ &= 1040 \text{ lumens} \end{aligned}$$

Likewise the indirect-component flux is

$$\begin{aligned} \phi_I &= \phi(90^\circ-180^\circ) - 4.93I(90^\circ) \\ &= 1622 - \frac{1040}{2} = 1102 \text{ lumens} \end{aligned}$$

and the direct component flux is

$$\begin{aligned} \phi_D &= \phi(0^\circ-90^\circ) - 4.93I(90^\circ) \\ &= 907 - \frac{1040}{2} = 387 \text{ lumens} \end{aligned}$$

The percentage of direct component flux in the 0° to 40° zone is

$$\begin{aligned} \frac{\text{total } \phi \text{ in } 0^\circ-40^\circ \text{ zone} - 0.67I(90^\circ)}{\text{total } \phi \text{ in } 0^\circ-90^\circ \text{ zone} - 4.93I(90^\circ)} &= \frac{254 - 0.67 \times 105}{387} \\ &= 49 \text{ per cent} \end{aligned}$$

The direct-component curve will therefore be classified as narrow.

The values of the component efficiencies and total efficiency of this luminaire are

$$\begin{aligned}\eta_I &= \frac{\phi_I}{\phi_L} = \frac{1102}{3000} &&= 0.367 \\ \eta_H &= \frac{\phi_H}{\phi_L} = \frac{1040}{3000} &&= 0.347 \\ \eta_D &= \frac{\phi_D}{\phi_L} = \frac{387}{3000} &&= 0.129 \\ \eta &= \frac{\phi(0^\circ-180^\circ)}{\phi_L} = \frac{2529}{3000} &&= 0.843\end{aligned}$$

Let this luminaire be employed in the room used as an illustration in Arts. 65 and 66, in which the coefficients of distribution (for an indirect system had there been any distinction in room index) were

$$\begin{aligned}C_I &= 0.34 \\ C_H &= 0.39 \\ C_D &= 0.76 \text{ (for narrow classification)}\end{aligned}$$

The resulting coefficient of utilization for the combination of room and luminaire is

$$\begin{aligned}K_u &= C_I\eta_I + C_H\eta_H + C_D\eta_D \\ &= 0.34 \times 0.37 + 0.39 \times 0.35 + 0.76 \times 0.13 \\ &= 0.126 + 0.137 + 0.099 \\ &= 0.36\end{aligned}$$

Values of coefficient of utilization are often tabulated for combinations of ceiling- and wall-reflection factors and room indexes for representative distribution curves. These tabulations are useful for a first rough check on the possibilities of various types of equipment. If the resulting illumination is desired to an accuracy of better than 10 or 20 per cent, the method just described should be used. Seldom is it possible that the shape of the distribution curve of the manufacturer's data will fit exactly any of the representative curves listed. The values of coefficients of utilization for representative types of distribution curves are given in Table 22. The maintenance factor shown with each type of luminaire will be discussed in Art. 68.

Although the coefficients of distribution were originally determined from incandescent units possessing vertical axes of symmetry, the results may be used in determining coefficients of utilization for luminaires not possessing such symmetry if the average distribution curve is used. In a paper entitled "The

Design of Luminaires for Fluorescent Lamps" in *Transactions of Illuminating Engineering Society*, November, 1940, the authors presented a table of coefficients of utilization for typical fluorescent fixtures. A portion of this table is reproduced in Table 23. A check of several dozen points at random from this table

TABLE 22.—COEFFICIENTS OF UTILIZATION*

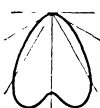
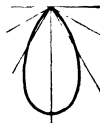
Type No.	Type of distribution and efficiency classification	Typical equipment representative of each group	Ceiling	75%			50%			30%			
			Walls	50%	30%	10%	50%	30%	10%	50%	30%	10%	
			Room index	Coefficients of utilization									
1	 <p>Distribution downward, 70% Maintenance factor, 0.70</p>	<i>High Bay Open Reflectors</i>	0 6	.40	.38	.36	.39	.38	.36	.39	.36	.39	.36
		0 8	.48	.46	.46	.47	.46	.45	.46	.45	.46	.43	.43
		a. Prismatic glass	1 0	.51	.51	.50	.50	.50	.49	.50	.48	.48	.48
		b. Mirrored glass	1 2	.55	.54	.54	.51	.52	.52	.52	.51	.51	.51
		c. Polished metal	1 5	.58	.56	.55	.55	.55	.54	.55	.53	.53	.53
		Source brightness—low at normal angles of view because of large shielding angle.	2 0	.60	.59	.58	.59	.58	.57	.57	.56	.56	.56
			2 5	.64	.61	.60	.62	.60	.60	.60	.59	.59	.59
			3 0	.65	.63	.61	.63	.62	.60	.60	.60	.60	.60
			4 0	.65	.64	.63	.64	.62	.62	.62	.62	.61	.61
			5 0	.66	.65	.64	.64	.63	.62	.62	.62	.62	.62
2	 <p>Distribution downward, 50% Maintenance factor, 0.70</p>	<i>Parabolic Polished Metal Reflectors</i>	0 6	.29	.27	.26	.28	.27	.26	.28	.26	.26	
		0 8	.34	.33	.32	.34	.32	.32	.32	.31	.31	.31	
		a. Louvered trough—inside-frosted lamps	1 0	.37	.36	.36	.36	.36	.35	.36	.34	.34	
			1 2	.39	.39	.38	.38	.38	.37	.38	.36	.36	
		b. Open reflectors—silvered-bowl lamps	1 5	.41	.40	.39	.40	.39	.38	.39	.38	.38	
			2 0	.43	.42	.42	.42	.42	.40	.41	.40	.40	
			2 5	.46	.44	.43	.44	.43	.42	.42	.42	.42	
			3 0	.46	.45	.44	.45	.44	.43	.43	.42	.42	
			4 0	.47	.46	.45	.46	.44	.44	.44	.44	.44	
			5 0	.47	.46	.46	.46	.45	.44	.44	.44	.44	

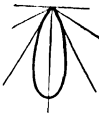
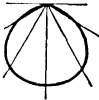

* From Illumination Design Data, General Electric Company, October, 1936.

TABLE 22.—COEFFICIENTS OF UTILIZATION.^a—(Continued)

Type No.	Type of distribution and efficiency classification	Typical equipment representative of each group	Ceiling	75 %			50 %			30 %	
			Walls	50 %	30 %	10 %	50 %	30 %	10 %	30 %	10 %
			Room index	Coefficients of utilization							
3	 <p>Distribution downward, 30 %</p> <p>Maintenance factor, 0.70</p>	<i>Prismatic Glass or Polished Metal Reflectors</i>	0.6	.17	.16	.16	.17	.16	.16	.17	.15
			0.8	.21	.20	.20	.20	.19	.20	.20	.19
			1.0	.22	.22	.21	.22	.21	.21	.21	.21
		<i>a. Enclosed lens plate</i>	1.2	.24	.23	.23	.23	.22	.22	.22	.22
			1.5	.25	.24	.24	.24	.23	.23	.23	.23
		<i>b. Open louvered</i>	2.0	.26	.25	.25	.25	.25	.24	.24	.24
			2.5	.27	.26	.26	.26	.26	.26	.26	.25
			3.0	.28	.27	.26	.27	.26	.26	.26	.26
			4.0	.28	.27	.27	.27	.27	.26	.26	.26
			5.0	.28	.28	.27	.28	.27	.27	.27	.26
		Care must be taken in location of units to avoid reflected glare from polished surfaces									
4	 <p>Distribution downward, 75 %</p> <p>Maintenance factor, 0.75</p>	<i>Distributing Type Open Reflectors</i>	0.6	.34	.29	.24	.34	.29	.24	.28	.24
			0.8	.42	.38	.34	.42	.37	.33	.37	.33
		<i>a. RLM Dome porcelain enameled—inside-frosted lamp</i>	1.0	.46	.43	.39	.45	.42	.39	.42	.39
			1.2	.50	.47	.43	.49	.46	.43	.45	.42
			1.5	.53	.50	.46	.52	.49	.46	.48	.45
		<i>b. Mirrored or prismatic glass—inside-frosted lamp</i>	2.0	.58	.55	.51	.57	.54	.51	.53	.51
			2.5	.62	.59	.56	.61	.58	.56	.58	.56
			3.0	.64	.61	.58	.63	.60	.58	.60	.58
			4.0	.67	.65	.63	.66	.64	.62	.63	.61
			5.0	.69	.67	.65	.67	.66	.64	.65	.63
		<i>Source brightness—uncomfortably high unless mounted either above 20 ft. or below eye level so that reflector shields the bright filament. F. C. on vertical—fairly high. Reflected glare—extremely severe from polished surfaces</i>									



^a From "Illumination Design Data," General Electric Company, October, 1936.

TABLE 22.—COEFFICIENTS OF UTILIZATION.^a—(Continued)

Type No.	Type of distribution and efficiency classification	Typical equipment representative of each group	Ceiling	75 %			50 %			30 %			
			Walls	50 %	30 %	10 %	50 %	30 %	10 %	30 %	10 %		
			Room index	Coefficients of utilization									
5	 <p>Distribution downward, 65 %</p> <p>Maintenance factor, 0.75</p>	<i>Distributing Type Open Reflectors</i>	0.6	.32	.28	.25	.32	.28	.25	.27	.25		
		a. RLM Dome porcelain enameled white-bowl lamp	0.8	.40	.36	.34	.39	.35	.33	.35	.33		
			1.0	.43	.39	.37	.42	.39	.37	.39	.37		
			1.2	.46	.43	.41	.45	.43	.41	.43	.41		
			1.5	.48	.45	.43	.47	.45	.43	.45	.43		
		b. RLM Deep bowl porcelain enameled inside-frosted lamp	2.0	.52	.50	.48	.51	.49	.47	.49	.47		
			2.5	.56	.54	.52	.55	.53	.51	.53	.51		
			3.0	.57	.55	.53	.56	.54	.52	.54	.52		
			4.0	.60	.58	.56	.59	.57	.55	.57	.55		
			5.0	.61	.59	.57	.60	.58	.57	.58	.56		
				<i>Source brightness</i> —moderately high but acceptably good for moderate levels of general illumination. <i>F. C. on vertical</i> —fairly high. <i>Reflected glare</i> —considerably less than clear lamp units—the dome rating better than the deep-bowl shape									
		6	 <p>Distribution downward, 60 %</p> <p>Maintenance factor, 0.70</p>	<i>Large-area Diffusing Reflectors</i>	0.6	.29	.24	.21	.28	.24	.21	.23	.21
				a. RLM Glassteel diffuser clear lamp	0.8	.36	.32	.29	.35	.31	.28	.30	.28
	1.0			.39	.36	.33	.38	.35	.33	.34	.32		
	1.2			.43	.39	.36	.41	.38	.36	.37	.35		
	1.5			.45	.42	.39	.43	.40	.38	.39	.38		
b. Silvered-bowl lamps in RLM Dome	2.0			.49	.46	.44	.47	.45	.43	.43	.42		
	2.5			.53	.50	.47	.51	.48	.46	.47	.46		
c. Enclosing glove parchment shade	3.0			.54	.52	.49	.52	.50	.48	.48	.47		
	4.0			.57	.55	.53	.55	.52	.51	.51	.50		
	5.0			.59	.56	.54	.56	.54	.52	.52	.51		
				<i>Source brightness</i> —relatively low. <i>F. C. on vertical</i> —moderately high. <i>Reflected glare</i> —suitably low for most industrial requirements									

^a From "Illumination Design Data," General Electric Company, October, 1936.

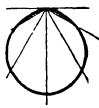
TABLE 22.—COEFFICIENTS OF UTILIZATION.^a—(Continued)

Type No.	Type of distribution and efficiency classification	Typical equipment representative of each group	Ceiling									
			75 %			50 %			30 %			
			Walls	50 %	30 %	10 %	50 %	30 %	10 %	30 %	10 %	
Room index			Coefficients of utilization									
7	 Distribution downward, 55 % Maintenance factor, 0.70	<i>Large-area Diffusing Panels</i>	0.6	.26	.22	.19	.25	.22	.19	.21	.19	
		0.8	.32	.29	.26	.31	.28	.26	.28	.26		
		<i>a. Extended trough reflector</i>	1.0	.35	.32	.30	.34	.32	.30	.31	.30	
		1.2	.38	.35	.33	.37	.35	.32	.34	.32		
		<i>cased opal glass cover</i>	1.5	.40	.37	.35	.38	.36	.35	.36	.35	
		<i>b. Enameled metal reflector with diffusing cover plate</i>	2.0	.43	.41	.39	.42	.40	.38	.40	.38	
		2.5	.46	.44	.42	.45	.43	.42	.43	.42		
		3.0	.48	.46	.43	.46	.45	.43	.44	.43		
		4.0	.50	.48	.46	.48	.47	.46	.46	.45		
		5.0	.51	.49	.48	.50	.48	.47	.47	.46		
		<i>Source brightness—generally low, and controllable by increasing area</i>										
8	 Distribution downward, 40 % Maintenance factor, 0.65	<i>Large-area Diffusing Panels</i>	0.6	.19	.16	.14	.18	.16	.14	.16	.14	
		0.8	.23	.21	.19	.23	.20	.19	.20	.19		
		<i>a. Solid opal or enameled glass cover</i>	1.0	.25	.23	.22	.25	.23	.22	.23	.22	
		1.2	.27	.25	.24	.27	.25	.24	.24	.24		
		1.5	.29	.27	.25	.28	.26	.25	.26	.25		
		<i>b. Enclosed skylight</i>	2.0	.31	.30	.28	.31	.29	.28	.29	.28	
		2.5	.34	.32	.30	.33	.32	.30	.31	.30		
		3.0	.35	.33	.32	.34	.32	.32	.32	.31		
		4.0	.36	.35	.34	.35	.34	.33	.34	.33		
		5.0	.37	.36	.35	.36	.35	.34	.34	.34		
		<i>This group is classified separately only because of lower light output. Source brightness—controllable by source area and diffusion</i>										
9	 Distribution downward, 25 % Maintenance factor, 0.60	<i>Combination Skylight</i>	0.6	.12	.10	.09	.12	.10	.09	.10	.09	
		0.8	.14	.13	.12	.14	.13	.12	.13	.12		
		<i>Skylights serving both natural and artificial lighting penalize efficiency because there is no help from multiple reflections. Quality factors with respect to direct and reflected glare and shadows are highly favorable</i>	1.0	.16	.15	.14	.16	.14	.14	.14	.14	
		1.2	.17	.16	.15	.17	.16	.15	.15	.15		
		1.5	.18	.17	.16	.18	.16	.16	.16	.16		
		2.0	.20	.19	.18	.19	.18	.18	.18	.18		
		2.5	.21	.20	.19	.20	.20	.19	.20	.19		
		3.0	.22	.21	.20	.21	.20	.20	.20	.20		
		4.0	.23	.22	.21	.22	.21	.21	.21	.21		
		5.0	.23	.22	.22	.22	.22	.21	.22	.21		

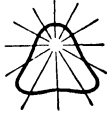
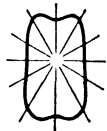

^a From "Illumination Design Data," General Electric Company, October, 1936

TABLE 22.—COEFFICIENTS OF UTILIZATION.^a—(Continued)

Type No.	Type of distribution and efficiency classification	Typical equipment representative of each group	Ceiling	75 %			50 %			30 %	
			Walls	50 %	30 %	10 %	50 %	30 %	10 %	30 %	10 %
			Room index	Coefficients of utilization							
10	 Distribution upward, 25 %; downward, 55 % Maintenance factor, 0.70	<i>Prismatic Glass Enclosing Unit</i>	0.6	.29	.24	.22	.27	.23	.21	.22	.20
			0.8	.35	.31	.29	.33	.29	.27	.28	.26
		or	1.0	.39	.35	.33	.36	.33	.31	.31	.29
		<i>Open Glass Reflector White-bowl Lamp</i>	1.2	.43	.39	.36	.39	.36	.34	.34	.32
			1.5	.46	.42	.38	.42	.39	.36	.37	.34
		<i>Source brightness—moderately high but acceptable in low-wattage units, or where seeing requirements are casual rather than fixed. F. C. on vertical—fairly high. Reflected glare—moderately severe—comparable with units in Group 5</i>	2.0	.50	.46	.43	.46	.43	.40	.40	.37
			2.5	.54	.49	.46	.49	.46	.43	.43	.41
			3.0	.56	.52	.48	.51	.48	.45	.45	.42
			4.0	.60	.56	.52	.54	.50	.48	.47	.45
			5.0	.62	.58	.55	.56	.52	.50	.49	.47
11	 Distribution upward, 35 %; downward, 45 % Maintenance factor, 0.75	<i>White Glass Enclosing Globe</i>	0.6	.24	.20	.17	.22	.18	.16	.16	.14
			0.8	.30	.25	.23	.27	.23	.20	.21	.19
		or	1.0	.34	.29	.26	.30	.26	.24	.24	.22
		<i>Projecting Luminous Element</i>	1.2	.37	.33	.30	.33	.29	.27	.27	.25
			1.5	.41	.36	.32	.36	.32	.29	.29	.27
		<i>Cased Opal Panels</i>	2.0	.45	.41	.37	.40	.36	.33	.32	.30
		<i>Source brightness—moderate, controllable within limits by globe size or luminous area. F. C. on vertical—fairly high. Reflected glare—fairly low</i>	2.5	.49	.44	.40	.43	.39	.36	.35	.33
			3.0	.52	.47	.43	.45	.41	.38	.37	.35
			4.0	.55	.51	.47	.48	.44	.42	.40	.38
			5.0	.57	.53	.50	.50	.46	.44	.41	.40

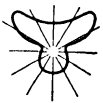
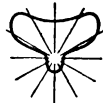

^a From "Illumination Design Data," General Electric Company, October, 1936.

TABLE 22.—COEFFICIENTS OF UTILIZATION.^a—(Continued)

Type No.	Type of distribution and efficiency classification	Typical equipment representative of each group	Ceiling	75 %			50 %			30 %		
			Walls	50 %	30 %	10 %	50 %	30 %	10 %	30 %	10 %	
			Room index	Coefficients of utilization								
12	 Distribution upward, 60 %; downward, 20 % Maintenance factor, 0.70	<i>Enclosed Translucent Bowls</i>	0.6	.16	.12	.09	.12	.09	.07	.06	.05	
			0.8	.20	.16	.13	.16	.12	.10	.09	.07	
		a. Prismatic glass	1.0	.24	.19	.16	.18	.14	.12	.11	.08	
		b. Cased glass	1.2	.27	.23	.19	.21	.17	.14	.12	.10	
		bottom etched top	1.5	.30	.25	.21	.23	.19	.16	.14	.12	
		Source brightness—usually satisfactory, should not exceed 1 candle per square inch for office and school applications. F. C. on vertical—somewhat less than semi-direct units. Reflected glare—inherently low	2.0	.35	.30	.26	.27	.22	.20	.17	.14	
			2.5	.38	.33	.29	.29	.25	.22	.19	.17	
			3.0	.41	.36	.32	.31	.27	.24	21	.19	
			4.0	.46	.41	.37	.34	.31	.29	.23	.21	
			5.0	.48	.44	.40	.37	.33	.31	.25	.23	
		13	 Distribution upward, 70 %; downward, 10 % Maintenance factor, 0.65	<i>Open-top Translucent Bowls</i>	0.6	.17	.14	.12	.13	.10	.09	.07
	0.8			.22	.18	.16	.16	.13	.12	.09	.08	
a. Dense glass bowl	1.0			.25	.21	.19	.18	.15	.14	.11	.09	
b. Plastic	1.2			.29	.25	.21	.21	.18	.16	.12	.11	
1.5	.31			.27	.24	.23	.20	.18	.13	.12		
Source brightness—very low. Other quality characteristics very excellent	2.0			.35	.31	.28	.26	.22	.20	.15	.14	
	2.5			.39	.34	.31	.28	.25	.23	.17	.16	
	3.0			.41	.37	.34	.30	.27	.25	.18	.17	
	4.0			.45	.42	.39	.32	.30	.28	.20	.19	
	5.0			.47	.44	.41	.34	.32	.30	.22	.20	
14	 Distribution upward, 75 %; downward, 0 % Maintenance factor, 0.65	<i>Shallow-bowl Reflectors and Shields</i>	0.6	.15	.12	.10	.10	.08	.07	.04	.04	
			0.8	.19	.15	.14	.13	.10	.09	.06	.05	
		a. Mirrored glass or metal bowl inside-frosted lamp	1.0	.22	.18	.16	.14	.12	.10	.08	.06	
			1.2	.25	.21	.18	.17	.14	.13	.08	.08	
			1.5	.27	.24	.21	.19	.16	.14	.09	.08	
		b. Metal shield—silvered bowl lamp	2.0	.31	.27	.25	.21	.18	.16	.10	.10	
			2.5	.34	.30	.28	.22	.20	.19	.12	.11	
			3.0	.36	.33	.30	.24	.22	.20	.13	.12	
		Indirect lighting inherently receives superior ranking from the standpoint of source brightness, reflected glare, shadows, and other quality considerations	4.0	.40	.37	.34	.26	.25	.23	.14	.14	
			5.0	.42	.39	.37	.28	.26	.25	.16	.14	

^a From "Illumination Design Data," General Electric Company, October, 1936.

TABLE 22.—COEFFICIENTS OF UTILIZATION.^a—(Continued)

Type No.	Type of distribution and efficiency classification	Typical equipment representative of each group	Ceiling	75 %			50 %			30 %		
			Walls	50 %	30 %	10 %	50 %	30 %	10 %	30 %	10 %	
			Room index	Coefficients of utilization								
15	 Distribution upward, 65%; downward, 0%	<i>Deep Metal Bowls and Troughs</i> Inherent qualities of indirect lighting	0.6	.13	.10	.09	.08	.07	.06	.04	.03	
			0.8	.16	.13	.12	.11	.09	.08	.05	.05	
			1.0	.19	.16	.14	.12	.10	.09	.06	.05	
			1.2	.22	.19	.16	.15	.12	.11	.07	.06	
			1.5	.24	.20	.18	.16	.14	.12	.08	.07	
			2.0	.27	.24	.21	.18	.16	.14	.09	.08	
			2.5	.30	.26	.24	.20	.18	.16	.10	.10	
			3.0	.32	.29	.26	.21	.19	.18	.11	.10	
			4.0	.35	.32	.30	.23	.21	.20	.12	.12	
			5.0	.36	.34	.32	.25	.23	.21	.14	.12	
16	 Distribution upward, 55%; downward, 0%	<i>Wall Urn</i> <i>Column Urn</i> <i>Wall Box</i> Limitations of space, the size and contour of special types of indirect reflectors generally sacrifice efficiency to achieve the balance and harmony called for in the general design plans	0.6	.11	.09	.07	.07	.06	.05	.03	.03	
			0.8	.14	.11	.10	.09	.08	.07	.04	.04	
			1.0	.16	.13	.12	.10	.09	.08	.06	.04	
			1.2	.18	.16	.13	.13	.10	.09	.06	.06	
			1.5	.20	.17	.15	.14	.12	.10	.07	.06	
			2.0	.23	.20	.18	.15	.13	.12	.08	.07	
			2.5	.25	.22	.20	.16	.15	.14	.09	.08	
			3.0	.27	.24	.22	.18	.16	.15	.09	.09	
			4.0	.29	.27	.25	.19	.18	.17	.10	.10	
			5.0	.31	.29	.27	.21	.19	.18	.12	.10	
17	 Distribution upward, 40%; downward, 0%	<i>Recessed Coves</i> <i>Coffers</i> In small wall coves and ceiling coffers where lamps must be deeply recessed the free opening is often relatively small and the cove output is correspondingly reduced	0.6	.08	.06	.05	.05	.04	.04	.02	.02	
			0.8	.10	.08	.07	.07	.06	.05	.03	.03	
			1.0	.12	.10	.09	.08	.06	.06	.04	.03	
			1.2	.13	.11	.10	.09	.08	.07	.04	.04	
			1.5	.15	.13	.11	.10	.08	.08	.05	.04	
			2.0	.17	.15	.13	.11	.10	.09	.06	.05	
			2.5	.18	.16	.15	.12	.11	.10	.06	.06	
			3.0	.19	.18	.16	.13	.12	.11	.07	.06	
4.0	.21	.20	.18	.14	.13	.12	.08	.07				
5.0	.22	.21	.20	.15	.14	.13	.08	.08				

^a From "Illumination Design Data," General Electric Company, October 1936.

TABLE 22.—COEFFICIENTS OF UTILIZATION.^a—(Continued)

Type No.	Type of distribution and efficiency classification	Typical equipment representative of each group	Ceiling	75 %			50 %			30 %		
			Walls	50 %	30 %	10 %	50 %	30 %	10 %	30 %	10 %	
			Room index	Coefficients of utilization								
18		<i>Close Ceiling</i>	0.6	.05	.04	.03	.03	.03	.02	.02	.01	
		<i>Coves</i>	0.8	.06	.05	.04	.04	.04	.03	.02	.02	
		Usually custom-built to fit individual architectural conditions, no general data are certain to apply to specific cases. In large important projects it may be necessary to build scale models to predetermine results	1.0	.07	.06	.05	.05	.04	.04	.02	.02	
			1.2	.08	.07	.06	.06	.05	.04	.03	.02	
			1.5	.09	.08	.07	.06	.05	.05	.03	.03	
			2.0	.10	.09	.08	.07	.06	.06	.04	.03	
			2.5	.11	.10	.09	.08	.07	.06	.04	.04	
			3.0	.12	.11	.10	.08	.07	.07	.04	.04	
			4.0	.13	.12	.12	.09	.08	.08	.05	.04	
			5.0	.14	.13	.12	.10	.09	.08	.05	.05	
			Maintenance factor, 0.55									





^a From "Illumination Design Data," General Electric Company, October, 1936.

proves the statement made above, since in no instance does the coefficient calculated from the general method vary more than 0.03 from the tabulated value and in many cases the check is exact. Thus as other luminaires are developed, the three-curve calculation method may be used to very good accuracy. To generalize this method still more to include asymmetrical luminaires would complicate it greatly in relation to the increase in accuracy thus obtained.

68. Computation of Illumination.—The coefficient of utilization having been determined, either accurately or approximately, the next step is the consideration of the average illumination as determined by the lamp lumens for an assumed layout as discussed in Art. 64.

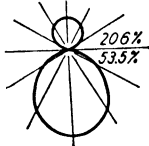
From the definition of the term *coefficient of utilization* [equation (109)] the number of lumens received at the working plane is the product of the lumens emitted by the lamps in the room and the coefficient of utilization. The lumens received at the working plane will be for the initial condition of the installation if the initial lumens of the lamps are used.

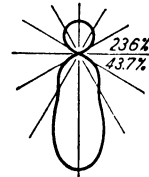
TABLE 23.—COEFFICIENTS OF UTILIZATION FOR FLUORESCENT LUMINAIRES.—(Continued)

Type No.	Distribution curves crosswise only	Ceiling	75%			50%			30%	
		Walls	50%	30%	10%	50%	30%	10%	30%	10%
		Room index	Coefficients of utilization							
25	Open-top Semi-concentrating Reflectors 	0.6	.33	.29	.27	.31	.28	.26	.27	.25
		0.8	.39	.36	.35	.37	.35	.33	.33	.31
		1.0	.43	.41	.39	.40	.38	.37	.37	.35
		1.2	.47	.44	.42	.44	.41	.40	.39	.39
		1.5	.50	.47	.44	.45	.43	.42	.42	.40
	Refracting Glass 	2.0	.53	.51	.48	.49	.47	.45	.45	.43
		2.5	.57	.53	.52	.52	.50	.49	.47	.46
		3.0	.58	.56	.53	.54	.52	.50	.49	.47
		4.0	.61	.58	.57	.55	.53	.52	.50	.49
		5.0	.62	.59	.58	.57	.55	.53	.51	.50
	26	Open-top Semi-concentrating Reflectors 	0.6	.30	.27	.26	.27	.26	.25	.26
0.8			.36	.33	.32	.33	.31	.30	.30	.28
1.0			.39	.37	.36	.36	.34	.34	.33	.32
1.2			.42	.40	.39	.39	.37	.36	.35	.34
1.5			.44	.42	.40	.40	.39	.38	.37	.35
Louvers 45° Cr. 30° Le. 		2.0	.47	.45	.44	.43	.42	.40	.39	.38
		2.5	.50	.48	.46	.45	.44	.43	.41	.40
		3.0	.52	.49	.47	.47	.45	.44	.41	.41
		4.0	.53	.51	.50	.48	.46	.46	.43	.42
		5.0	.54	.53	.51	.49	.47	.46	.44	.43
27		Open Top 	0.6	.32	.27	.23	.29	.25	.21	.23
	0.8		.38	.33	.29	.34	.29	.26	.27	.24
	1.0		.44	.38	.34	.38	.36	.30	.30	.25
	1.2		.47	.42	.38	.42	.38	.34	.33	.31
	1.5		.50	.45	.41	.44	.40	.37	.35	.33
	Open Bottom 	2.0	.56	.51	.47	.49	.45	.42	.40	.38
		2.5	.60	.56	.52	.52	.49	.47	.44	.42
		3.0	.63	.59	.55	.55	.51	.49	.46	.44
		4.0	.67	.64	.61	.58	.56	.54	.49	.47
		5.0	.70	.67	.65	.60	.59	.57	.51	.51

Allowance must be made for the depreciation of light output of the lamps as they age and also for dust and dirt which collect on the luminaire even with a reasonable cleaning schedule. The maintained illumination for the average fixture under average cleaning conditions is in the order of 70 per cent of the initial value. Some luminaires may not be susceptible to the collection of dust on surfaces that affect the luminous efficiency of the unit. For such equipment a higher maintenance factor may be used. For others, particularly indirect types and any in which the cleaning schedule may be poor, the maintenance factor may be considerably lower than 70 per cent. A maintenance factor for each type of luminaire shown is given in Tables 22 and 23.

Summarizing the conditions stated into the form of an equation gives

$$\phi_L = \frac{E \times A}{N \times K_u \times M} \quad (110)$$

where ϕ_L = initial lumens per lamp.

E = maintained average illumination.

A = area of room.

N = total number of lamps.

K_u = coefficient of utilization.

M = maintenance factor.

If for a desired value of illumination the calculated initial lumens per lamp do not coincide with those of a commercial size lamp, then either the number of lamps used can be varied by another assumption as to layout or a lamp size can be chosen such that the original layout gives either a higher or lower illumination. Judgment must decide which plan should be followed in any particular case. If the latter plan is followed, the choice of lamp size may be made according to any arbitrary rule. Generally if the number of lumens per lamp is more than one-third the value between commercial lamp lumens, the larger lamp would be used. A more critical evaluation of maintenance factor for the particular use may also enter into the considerations.

Problems

1.11. A room has a floor area of 26 by 16 ft. 9 in. and a ceiling height of 13 ft. Determine the room index for a semi-direct lighting system with the luminaires suspended 30 in.

2.11. The apparent candle-power distribution curve of a diffuse enclosing globe luminaire is given below. A 200-watt, 115-volt, PS30 inside-frosted bulb was used in the luminaire during the test. The output of this lamp during the test was 3680 lumens.

a. Compute the indirect-, horizontal-, and direct-component fluxes of this luminaire. Classify the direct component as narrow, medium, or broad.

b. Compute the component efficiencies of the luminaire and the total efficiency.

DISTRIBUTION DATA FOR PROB. 2.11

Mid-zone angles, deg.	Apparent candle power at 10 ft.	Mid-zone angles, deg.	Apparent candle power at 10 ft.
180 zenith	310	0 nadir	457
175	309	5	454
165	302	15	442
155	292	25	414
145	267	35	377
135	236	45	330
125	198	55	286
115	175	65	246
105	175	75	216
95	180	85	194
90 horizon	186		

3.11. Design a layout for the room in Prob. 1.11 using the luminaire of Prob. 2.11 suspended 30 in. The room has no architectural restrictions. If the reflection factor of the ceiling is 0.70 and the weighted average reflection factor of the walls (including furniture, windows, etc.) is 0.28, what will be the initial average illumination on the working plane of the room for the number of luminaires used?

4.11. Assume that a series of luminaires are available of the form of that in Prob. 2.11 for the following lamp sizes: 150 watts, 200 watts, 300 watts, and 500 watts. If the relative distribution curves of all of these luminaires are similar, what respective maintained average illumination can be expected if each size were used in the layout of Prob. 3.11. Use a maintenance factor of 0.75.

REFERENCES

- W. Harrison and E. A. Anderson, Illumination Efficiencies as Determined in an Experimental Room, *Trans. Illum. Eng. Soc. (N.Y.)*, **11**, 1916, pp. 67-91.
- W. Harrison and E. A. Anderson, Coefficients of Utilization, *Trans. Illum. Eng. Soc. (N.Y.)*, **15**, 1920, pp. 97-123.
- "Illumination Design Data," General Electric Company, October, 1936.
- Specifications for Testing Lighting Equipment, *Trans. Illum. Eng. Soc. (N.Y.)*, **35**, 1940, pp. 267-275.

CHAPTER 12

LUMINOUS ARCHITECTURAL ELEMENTS

<i>Symbol</i>	<i>Term</i>	<i>Definition</i>
	Luminous architectural element	Any luminous panel, cove, coffer, niche, molding, column, pilaster, beam, or similar element that on its own accord is an integral part of an architectural treatment.
η	Element efficiency	The ratio of the luminous flux emitted by that portion of the area of the element assigned to one lamp to the luminous flux emitted by that lamp.

69. General.—The employment of luminous architectural elements is quite common practice in many interior and exterior applications. Such elements are necessarily custom-made for each application, and the general problem becomes one not for the illumination engineer alone but also for the architect and the artist.

Certain fundamental principles concerning light control, efficiencies, desirable brightnesses, uniformity, and similar objective quantities under the control of the illumination engineer are the subject matter of this chapter. The problems of achieving the desired mass, line, and symmetry are problems of the architect and artist and will not be dealt with here. In the application of luminous elements, then, a close cooperation between the illumination engineer and the architect or artist is extremely important.

The design of luminous elements may be controlled to give several subjective effects. These effects may range from an impression of extremely uniform brilliance of the element on one hand to a very sparkling highlight effect of the element on the other. The elements may be classified objectively under one of four types.

a. Elements of Uniform Brightness.—These elements are perhaps the most generally applied form of architectural element. If the primary source is placed behind the element, then highly diffusing materials such as solid- or flashed-opal glassware or

translucent plastics are required. If the source providing luminous flux to the element is a secondary source, itself of reasonably diffuse character, the degree of diffusion necessary in the translucent material, which acts more as a cover plate, may be much less. If there is no abrupt change in the brightness of the element, the subjective effect of uniform brilliance may be retained even though the ratio of maximum to minimum brightness of element is as large as 1.5.

b. Elements of Graduated or Shaded Brightness.—If the change of brightness of the element is gradual but of rather large degree, very interesting and decorative effects may be obtained. These results are usually obtained by lighting the element from only one side or by large spacings between rows of lamps. Line sources of light such as fluorescent lamps may be used very effectively in this form of element.

c. Elements Producing Banded Effects.—Transmitting elements formed of fluted or ribbed glass or plastics and reflecting elements formed of corrugated reflecting backgrounds produce banded effects which are highly interesting and spectacular, particularly if color is used.

d. Elements of Spotty Brightness.—Elements of spotty brightness with definite brightness patterns may be used very effectively for certain decorative purposes. Such elements are not suitable for sign-letter backgrounds or where the brightness of the brightest part of the pattern is so great as to be glaring. Low-diffusion materials with lamps spaced close to the element produce this type of element with a great deal of sparkle and highlighting. Materials with more diffusion with lamps spaced relatively far apart produce softer spots.

70. Exterior Applications of Luminous Elements.—In exterior applications, luminous elements are generally used for display and decoration or for luminous signs or backgrounds for silhouettes. Only seldom is the illumination as produced by the element upon any receiver surface of any great usefulness. Consequently the selection of the brightness level of the element is usually much less than that which may be employed in interior applications where the luminous element may be producing a useful illumination upon a working plane.

Table 24 gives suggested luminosity values for various exterior applications. If the luminous element is diffusing, the bright-

ness may be obtained by dividing the luminosity by π . Otherwise the methods suggested in Art. 71 should be used.

TABLE 24.—SUGGESTED LUMINOSITY VALUES: EXTERIOR APPLICATIONS^a

The selection of luminosity levels is influenced by the following conditions:

- (a) Character, size, and brightness of immediately adjacent (competitive) displays.
- (b) Signs as such should always be brighter than other portions of a design.
- (c) Character of the institution; *e.g.*, a conservative business will require less bright displays than a theater.
- (d) Relations in brightness of an element to another of the same display, for the purpose of producing emphasis or a design in brightness.
- (e) Extent of entire pattern and size of the elements. Lower brightness may suffice when scale is large.
- (f) In color, a lower brightness often proves effective.

Type and application of luminous element	General brightness of district		
	Low	Medium	High
	Luminosity, foot-lamberts		
Decorative flush elements (principal units in design), including panels and recesses.	30-100	50-150	100-300
Decorative projecting elements (principal units in design).....	50-130	70-170	150-300
Decorative elements, <i>e.g.</i> , spandrels and niches (particularly when subordinate elements in design).....	30- 60	40- 80	50-150
Luminous background signs.....	90-150	120-200	150-350
Luminous letter-stroke signs.....	150-200	200-400	300-600
Small luminous facades (as small entirely luminous store fronts and buildings)....	80-120	100-150	120-200
Marquee and entrance soffits and marquee fasciae.....	80-150	100-250	200-400
Luminous beams under canopies and marquees (restricted size, as for gasoline service stations).....	150	250	400
Pylons (as for gasoline service stations, entrance markers, etc.).....	100	200	300

^a From "Illumination Design Data," General Electric Company, October, 1936.

71. Interior Applications of Luminous Elements.—In exterior elements the luminosity of the element may be a very good criterion of design, since the brightness of the element at its brightest part is generally below such a value as to cause glare.

This is especially true if the element material has a rather good diffusing quality. However, in interior applications of luminous elements it may be desirable to increase brightness of the element to as high a value as is permissible without excessive glare. Consequently the maximum *brightness* of the element is the limiting factor and not its luminosity. Of course the brightness and luminosity are still related through the factor of π if the surface of the element is perfectly diffusing. Table 25 gives the limiting values of brightness expressed in candles per square inch for the various classifications of interior elements and also the corresponding luminosities for perfectly diffusing elements.

TABLE 25.—SUGGESTED MAXIMUM BRIGHTNESS VALUES: INTERIOR APPLICATIONS^a

Factors that influence the selection of a limiting brightness for elements:

- (a) *Contrast with Surrounding Surfaces.*—Too great a contrast produces an unfavorable appearance; hence the brighter the surroundings, the higher can be the brightness of the elements.
- (b) *Illumination in the Room.*—For equal glare effect, the illumination must be increased by ten times to permit doubling the brightness of the units.
- (c) *Position of Elements.*—They may be brighter when mounted high out of the usual field of view or when their light is not directed toward the observer.
- (d) *Casual or Prolonged Viewing.*—Higher brightnesses are acceptable where people are passing than where they are in one position for a considerable period as in an office or auditorium.
- (e) *Size of Luminous Area.*—As luminous area is increased, the brightness selected should be lower. This is especially true of elements in walls.

Classification of source	Brightness, candles/sq. in.	Luminosity of perfect diffuser, foot-lamberts
(a) Protruding ceiling elements, 20 ft. or more above floor.	1	500
(b) For elements in low ceilings, particularly in larger rooms (lower over mezzanine).	0.5	250
(c) Wall panels or recesses in passages.	0.4	200
(d) Wall panels and niches not usually in line of sight.	0.3	125
(e) Decorative panels constantly in view . . .	0.2	75

^a From "Illumination Design Data," General Electric Company, October, 1936.

72. Reflecting Materials.—Classifications of reflecting materials as to specular, mat (diffuse), and semi-mat have been made

in Chap. 8. The terminology as established there is continued here. Table 26 gives the range of reflection factors of several materials used in architectural elements as determined for illumination from incandescent lamps. None of the materials listed is extremely selective as to spectral reflection, and conse-

TABLE 26.—REFLECTING MATERIALS^a

Material	Classification	Reflection factor (incandescent light)
Aluminum-alloy film on glass.....	Specular	0.90-0.94
Silver plate.....	Specular	0.87-0.92
Glass mirror.....	Specular	0.80-0.90
Aluminum foil.....	Specular	0.85-0.87
Alzak aluminum.....	Specular	0.75-0.84
Rhodium.....	Specular	0.70-0.78
Aluminum, polished.....	Specular	0.60-0.72
Tin.....	Specular	0.68-0.71
Chromium.....	Specular	0.62-0.67
Stainless steel.....	Specular	0.55-0.65
Nickel.....	Specular	0.60-0.63
Monel.....	Specular	0.57-0.62
Aluminum, mill finish.....	Specular	0.53-0.55
Black structural glass.....	Specular	0.04-0.05
Alzak aluminum.....	Semi-mat	0.72-0.80
Oxidized and etched aluminum.....	Semi-mat	0.70-0.86
Aluminum, brushed.....	Semi-mat	0.55-0.57
Chromium, satin.....	Semi-mat	0.50-0.56
Stainless steel, satin.....	Semi-mat	0.52-0.56
Magnesium carbonate.....	Mat	0.93-0.97
White plaster.....	Mat	0.90-0.92
White paint.....	Mat	0.75-0.88
White porcelain enamel.....	Mat	0.60-0.82
White and cream terra cotta.....	Mat	0.60-0.80
White structural glass.....	Mat	0.74-0.78
Limestone.....	Mat	0.35-0.58
Sandstone.....	Mat	0.20-0.42
White porcelain enamel.....	Specular and mat	0.60-0.80

^a From "Illumination Design Data," General Electric Company, October, 1936.

quently the reflection factors may be applied to any type of illumination. Certain materials are shown under several classifications where differences in manufacture result in different reflecting properties.

73. Transmitting Materials.—The choice of a transmitting material is more involved than the choice of a reflecting material if the unlighted appearance of the element is important. Materials such as the opal glasses generally reflect a considerable amount of light and appear rather white in daylight. The transmission of such glasses is consequently rather low. Table 27 gives the transmitting characteristics of several materials used in architectural elements. The transmission factor is for incandescent light and for the usual range of thickness used. The factors may be used for other illuminates except for those materials which are spectrally selective.

TABLE 27.—TRANSMITTING MATERIALS*

Material	Classification	Transmission factor (incandescent light)
Fused quartz.....	Transparent	0.91-0.93
Clear glass.....	Transparent	0.80-0.90
Glass, clear mat (1).....	Semi-translucent	0.75-0.89
Glass, clear mat (2).....	Semi-translucent	0.62-0.87
Glass, clear configurated...	Semi-translucent	0.67-0.87
Plastic, clear mat.....	Semi-translucent	0.60-0.80
Alabaster glass configurated	Semi-translucent	0.60-0.70
Opalescent glass.....	Translucent	0.55-0.85
Flashed-opal glass.....	Translucent	0.30-0.52
Alabaster.....	Translucent	0.18-0.50
Solid-opal glass.....	Translucent	0.12-0.40
Enameled glass.....	Translucent	0.27-0.38
White plastic, diffuse.....	Translucent	0.03-0.35
Marble, impregnated.....	Translucent	0.00 ⁺ -0.21
Amber glass.....		0.40-0.60
Green glass.....		0.10-0.15
Red glass.....		0.07-0.14
Blue glass.....		0.01-0.04

* From "Illumination Design Data," General Electric Company, October, 1936.

74. Spacing of Lamps in Luminous Elements for Reasonably Uniform Brightness.—The diffusing property of the transmitting or reflecting material determines the spacing of lamps in luminous elements. As materials are more diffusing, the maximum spacing

TABLE 28.—ELEMENT FORMS AND EFFICIENCIES
a. *Half-cylinder Recess*

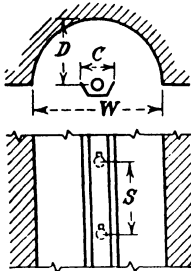

$$\begin{aligned} D &= 0.5W \\ S &= 0.95W \\ S &= 1.9D \\ A &= (W - C)S \end{aligned}$$

Efficiency for 0.75 reflection factor background is 43 per cent. For other surfaces efficiency is $\rho \times 57$ per cent.

Produces a sharply defined luminous area. Range of effects attainable—uniformity with diffuse background, sparkle, glitter, or banded effects with crinkled, fluted, or brushed metallic background.

b. *Shallow Recess*

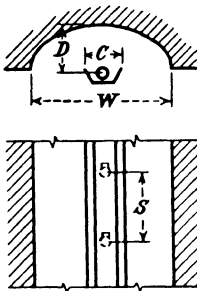

$$\begin{aligned} D &= 0.17W \\ S &= 0.25W \\ S &= 1.5D \\ A &= (W - C)S \end{aligned}$$

Efficiency for 0.75 reflection-factor background is 38 per cent. For other surfaces efficiency is $\rho \times 50$ per cent.

Shallow cavities produce slightly graduated brightness. As in half-cylinder recess a range of effects is attainable. Check dimensions with physical size of lamp used to ensure ample allowance for inserting lamps.

c. *Plane-surface Reflector*

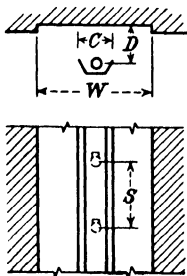

$$\begin{aligned} D &= 0.33W \\ S &= 0.50W \\ S &= 1.5D \\ A &= (W - C)S \end{aligned}$$

Efficiency for 0.75 reflection-factor background is 30 per cent. For other surfaces efficiency is $\rho \times 40$ per cent.

Width is based on 5 to 1 variation of brightness from center to edge. In design of cross-section trough, cutoff and angle of view are very important.

TABLE 28.—ELEMENT FORMS AND EFFICIENCIES.—(Continued)
d. Double Recess

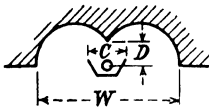

$$D = 0.07W$$

$$S = 0.50W$$

$$A = (W - C)S$$

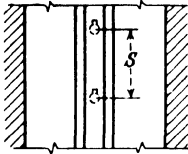

Efficiency for 0.75 reflection-factor background is 39 per cent. For other surfaces efficiency is $\rho \times 52$ per cent.

Spacing of lamps to mid-line of element is small, but interreflection of flux from this region to outside edges of element reduces brightness graduation.

e. Semi-shallow Recess Side Lighted

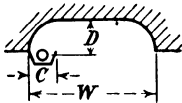

$$D = 0.33W$$

$$S = 0.33W$$

$$S = D$$

$$A = (W - C)S$$

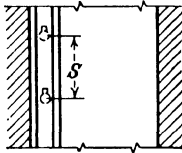

Efficiency for 0.75 reflection-factor background is 25 per cent. For other surfaces efficiency is $\rho \times 33$ per cent.

A graduated brightness is produced by lamps at one side; uniformity if lamps are located on each side with ratios as given. In small elements allow for easy lamp replacement.

f. Silhouette Background

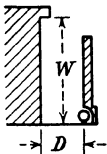

$$D = 0.25W$$

$$S = 0.56W$$

$$S = 2.25D$$

$$A = W'S$$

Efficiency for 0.75 reflection-factor background is 25 per cent. For other surfaces efficiency is $\rho \times 33$ per cent.

Requires polished-metal parabolic trough reflectors with maximum candle power directed to the far edge of surface. With ratios given brightness graduations will be of the order of 25 to 1. The degree of shading can be lessened by the use of a larger, more concentrating reflector and by increasing D with respect to W .

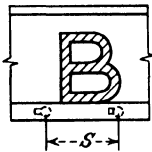

TABLE 28.—ELEMENT FORMS AND EFFICIENCIES.—(Continued)
g. Flush Panel

$$D = \frac{0.67}{a} W$$

$$S = \frac{1}{a} W$$

$$S = 1.5D$$

$$A = \frac{1}{a} WS$$

a = number of rows of lamps

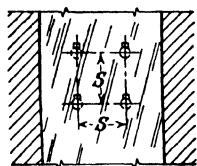
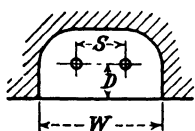

Transmission Factor of Glass	Efficiency, Per Cent
0.80	65
0.70	61
0.60	56
0.50	51
0.40	44
0.30	35
0.20	25

Representative of a great variety of forms ranging from a narrow band requiring a single row of lamps to large expanses of luminous glass areas requiring a wide variety of lamp arrangements. Efficiencies vary slightly with size and form, but spacing between lamps should conform to the cavity depth and type of translucent material used.

h. Corner Panel

$$D = 0.4W$$

$$S = 0.6W$$

$$S = 1.5D$$

$$A = WS$$

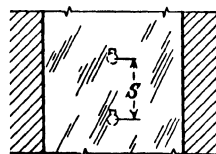
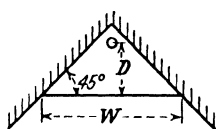

Transmission Factor of Glass	Efficiency, Per Cent
0.80	70
0.70	66
0.60	60
0.50	54
0.40	46
0.30	37
0.20	26

Lamps should be placed in the corner to permit wider spacing and better lateral uniformity of brightness with highly diffusing materials. A slight shading of brightness at the sides may be noticed.

TABLE 28.—ELEMENT FORMS AND EFFICIENCIES.—(Continued)

i. *Semi-shallow-recess Panel*

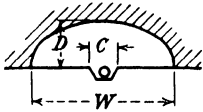

$$D = 0.33W$$

$$S = 0.67W$$

$$S = 2D$$

$$A = (W - C)S$$

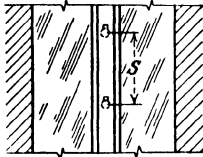

Transmission Factor of Glass	Efficiency, Per Cent
0.80	37
0.70	33
0.60	29
0.50	25
0.40	21
0.30	17
0.20	13

Indirectly lighted transilluminated elements of this character may use any type of translucent material, the choice being governed by the unlighted appearance, texture, and efficiency.

j. *Shallow-recess Panel Side-lighted*

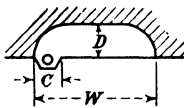

$$D = 0.17W$$

$$S = 0.30W$$

$$S = 1.8D$$

$$A = (W - C)S$$

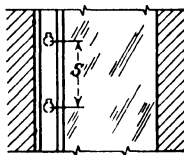

Transmission Factor of Glass	Efficiency, Per Cent
0.80	21
0.70	20
0.60	19
0.50	17
0.40	15
0.30	12
0.20	8

A graduated brightness will be obtained by a single trough located on one side; uniformity if lamps are placed at each side with the ratios as given. For choice of transmitting medium see "Semi-shallow Recess Panel" above.

TABLE 28.—ELEMENT FORMS AND EFFICIENCIES.—(Continued)
k. Shallow Reflector Side-lighted Panel

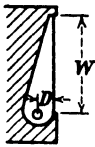

$$D = 0.10W'$$

$$S = 0.20W'$$

$$S = 2D$$

$$A = WS$$



Transmission Factor of Glass	Efficiency, Per Cent
0.80	40
0.70	38
0.60	35
0.50	31
0.40	26
0.30	20
0.20	13

With highly diffusing translucent materials, the contour of the reflecting background is relatively unimportant. With less diffusing materials, the shape affects the graduation of brightness as does the angle of view.

l. Angular Projecting Element

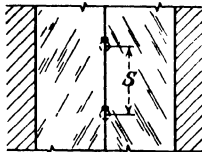
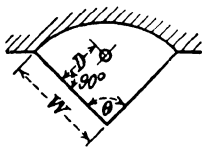

	θ		
	70°	90°	120°
$D =$	$0.35W'$	$0.50W'$	$0.87W'$
$S =$	$0.53W'$	$0.75W'$	$1.3W'$
$S =$	$1.5D$	$1.5D$	$1.5D$
$A =$	$2WS$	$2WS$	$2WS$

Transmission factor of glass	θ		
	70°	90°	120°
	Efficiency, per cent		
0.80	..	83	74
0.70	..	79	70
0.60	81	73	65
0.50	76	65	57
0.40	68	54	48
0.30	54	44	36
0.20	40	33	29

The depth of the cavity will be determined through the ratios of D to W for the particular angle of element. (Note: D is not defined in the original references and hence certain ratios given therein may not agree with those above, except S/D is held at 1.5.)

TABLE 28.—ELEMENT FORMS AND EFFICIENCIES.—(Continued)
m. Rectangular Projecting Element

	<i>E/W</i>		
	0.25	1.00	1.83
$D =$	$\frac{0.74}{a} W$	$\frac{0.50}{a} W$	$\frac{0.50}{a} W$
$S =$	$\frac{1}{a} W$	$\frac{0.75}{a} W$	$\frac{0.75}{a} W$
$S =$	$1.4D$	$1.5D$	$1.5D$
$A =$	$(2E + W)S$		
$a =$	$\frac{a}{\text{rows of lamps}}$		

	<i>E/W</i>		
	0.25	1.00	1.83
Transmission factor of glass	Efficiency, per cent		
	0.80	0.78	0.79
	0.70	0.74	0.76
	0.60	0.70	0.71
	0.50	0.63	0.65
	0.40	0.54	0.56
	0.30	0.44	0.46
	0.20	0.30	0.34

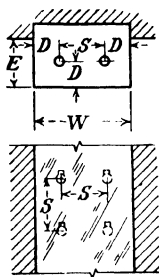

For elements in which the ratio of *E* to *W* is small a recess will be necessary. For larger ratios of *E* to *W* the recess may be eliminated. Note that the square element is more efficient than either an extremely shallow or a deep element.

n. Quarter Cylinder

$$S = 1.5D$$

$$A = \frac{\pi}{2} DS$$

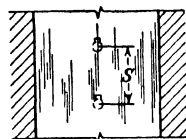
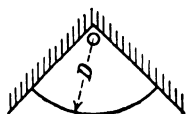

Transmission Factor of Glass	Efficiency, Per Cent
0.80	0.74
0.70	0.70
0.60	0.65
0.50	0.57
0.40	0.48
0.30	0.36
0.20	0.28

This element has essentially the same efficiency as the 120-deg. projecting element. For half cylinder multiply efficiency by 1.05.

TABLE 28.—ELEMENT FORMS AND EFFICIENCIES.—(Continued)
o. Square Column

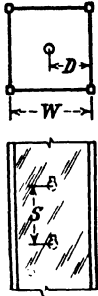

$$D = 0.5W$$

$$S = 0.7W$$

$$S = 1.4D$$

$$A = 4WS$$

Transmission Factor of Glass	Efficiency, Per Cent
0.80	0.92
0.70	0.90
0.60	0.87
0.50	0.83
0.40	0.76
0.30	0.65
0.20	0.48

Lamps should be centered in the column and positioned to avoid socket shadows. Conduit risers should be brought up in one corner so that framing conceals it.

p. Cylinder



$$S = 1.4D$$

$$A = 2\pi DS$$

Transmission Factor of Glass	Efficiency, Per Cent
0.80	93
0.70	92
0.60	90
0.50	87
0.40	79
0.30	68
0.20	54

Conduit riser should be located on least conspicuous side.

of lamps at a given distance from the diffusing medium becomes greater. The geometric arrangement of the light sources with reference to the diffusing medium and the geometry of the light source itself as well as the possibility of interreflections within the element influence the spacing limitations.

The critical spacing of lamps may be expressed as the ratio of the distance between light centers to the distance from the diffusing medium to the light centers. If the lamps are tubular lamps, as incandescent or fluorescent lumines, the critical spacing is the distance between rows of lamps.

For materials of low diffusion, such as ground glass and con-figured alabaster, the maximum ratio is approximately 0.3, whereas with solid-opal glass the ratio may be as high as 2. For flashed-opal glass the ratio is approximately 1.5 for many configurations of elements.

Table 28 gives the design limitations for a number of luminous elements. The diffusing material intended therein for transmitting elements is flashed-opal glass and for reflecting surfaces a good-quality flat paint. Where other materials than these are used, the limiting dimensions will in general need revision if reasonably uniform brightness is to result.

The dimensional ratios are self-described in each figure. The area A as shown is the area per lamp that is used in determining the lamp sizes and the efficiency of the element. The element efficiency is the ratio of the lumens emitted by the element of area A to the lumens emitted by each lamp.

75. Calculations upon Element Forms.—The maximum brightness of the element can be determined from the relationship of equation (111). For spacings such that the brightness is reasonably uniform, the constant k in the equation may be taken as 1.0. If single frosted glass is used and the spacings from lamp to glassware are not increased, the factor should be taken as approximately 4. Inserting this value in equation (111) does not eliminate spotty brightness. In fact for some applications this elimination may not be desirable. However, it does preclude the possibility of having in the field of view a brightness that is excessive to the extent of producing glare.

The relationship being discussed is

$$B_m = k \frac{\eta \phi_L M}{\pi A} \quad (111)$$

where B_m = maximum brightness of the element, in candles per square inch.

η = efficiency of the element.

ϕ_L = flux per lamp, in lumens.

M = maintenance factor.

A = area per lamp, in square inches, as from Table 28.

k = 452 times the maximum brightness in the field of view, in candles per square inch, divided by the average luminosity over A , in lumens per square foot.

The term *element efficiency* loses a great deal of its meaning when the element is not even approximately diffusing. For sparkle and banded effects the calculation of brightness becomes rather involved, since the maximum brightness may not be influenced appreciably by the area of the element but may be determined more by the brightness of the lamp source itself. In general, the less diffusing the element the greater must be the spacing of the lamp to the element surface. Beggs and Woodside have shown that for flashed-opal glassware, for example, the maximum to minimum brightness is only about 1.3 and is fairly independent of distance of the lamp source to the glass surface. Acid-frosted glass, however, will have a brightness ratio of approximately 1.5 if the distance from lamp to glass is 9 in., whereas the ratio is approximately 4 if the lamp is only 4 in. from the glass. A calculation of brightness should not be attempted from equation (111) if a less diffusing material than single frosted glass is used. For such materials the brightness as determined from equation (112) will more nearly represent the maximum brightness of the element. However, now the error in maximum brightness will be smaller the lower the diffusing qualities of the material. Logically a factor less than one should be inserted in this equation to take account of such diffusion, but no data upon factors are known to the author.

$$B_m = \tau(\text{or } \rho)B_m' \quad (112)$$

where B_m = maximum brightness of the element, in candles per square inch *if diffusion is small*.

$\tau(\text{or } \rho)$ = transmission factor (or reflection factor) of element.

B_m' = maximum brightness of source of light as viewed from transmitting (or reflecting) medium, in candles per square inch.

An example will illustrate the use of the equation relating the maximum brightness, the efficiency of the element, the spacings and size of lamp. Suppose that a flush panel as is illustrated in Table 28 (*g*) is to be used, that the width of the panel is limited by architectural features to 7 in., and that the available depth for the recess is 10 in. Beyond this point any one of a number of variables may be determined if the other controlling factors are known. Suppose, for this example, that the length of the panel is to be fixed at 24 in. and the use is such that the

brightness of the element shall be not more than 0.5 candle per square inch, since the panel is to be used over a breakfast nook in a residence that would be classified as a low-ceiling element of Table 25. The maximum size of lamps and their arrangement is to be determined.

If the value of $W = 7$ in. is substituted into the empirical relationships of Table 28 (*g*), the values of D and S are

$$D = \frac{4.7}{a}$$

$$S = \frac{7}{a}$$

The available depth of the recess is such that one row of lamps will suffice; hence

$$D = 4.7 \text{ in.}$$

$$S = 7 \text{ in.}$$

Because the panel is fixed at 24 in. long, the number of lamps to be used (if incandescent lamps are used) will be $24/7 = 3.43$ lamps. Unless a very dense solid-opal glass is to be used, three lamps will give a spotty effect. Consulting Table 27, one finds that the transmission of solid-opal glass is 0.12 to 0.40. If spotty effects are to be avoided, an opal glass having a transmission factor nearer the lower end of this range must be used. On the other hand, flashed-opal glass has a transmission factor of 0.30 to 0.52. The gain in efficiency of the unit from 25 per cent at a 0.20 transmission factor to 51 per cent at a 0.50 transmission factor is evidence that four lamps should be used behind flashed opal glass. Therefore the corrected value of S to fit an integer number of lamps is

$$S = \frac{24}{4} = 6 \text{ in. (corrected)}$$

and

$$A = WS = 7 \times 6 = 42 \text{ sq. in.}$$

The only remaining calculation is the maximum lamp size that can be used without exceeding the brightness limitation. In determining this lamp size the value of M in equation (111) should be taken as 1.0, since the brightness experienced with

new lamps and clean glassware will determine the worst condition of glare. If single flashed-opal glass is used having a transmission factor of 0.50 the element efficiency will be 51 per cent. With such glassware essentially uniform brightness results, and hence k may be taken as 1.0. Substituting these values in equation (111) gives

$$\phi_L \cong \frac{\pi AB_m}{k\eta M} = \frac{\pi \times 42 \times 0.5}{1.0 \times 0.51 \times 1.0} = 129 \text{ lumens}$$

Reference to Table 7 giving data on incandescent lamps indicates that a 15-watt lamp is rated at 150 lumens. This is practically the value obtained for ϕ_L , and hence lamps as large as 15 watts may be used.

An alternative solution of the problems is the use of fluorescent lamps rather than incandescent. The 15-watt lamps are manufactured in an 18-in. length; the 20-watt lamps, in a 24-in. length; and others, in lengths longer than the desired architectural element. Hence the only fluorescent lamps possible are the 15- and 20-watt sizes. The critical spacing of 7 in. will not be exceeded if the 18-in. lamp is used, since the distance from the end of the lamp to the end of the element would be only 3 in. with the lamp centered longitudinally. A tubular lamp has a low candlepower distribution from its end due to the socket, and consequently it is well not to crowd the critical spacing in this dimension. However, the factor of safety here is over 2, and reasonably uniform brightness will result with flashed-opal glassware.

The total lumens to be emitted by the lamps must not be more than 4×129 , or 516. If "white" fluorescent lamps are to be used, reference to Table 10 indicates that the 15-watt size emits 615 lumens whereas the 20-watt size emits 900 lumens. The 20-watt lamp is obviously too large, but the 15-watt size could be used with probably no excessive glare.

The ultimate choice of a lamp size depends upon what brightness is desired in order to produce an effect at some receiver plane. As is discussed in Chap. 4, such calculations are extremely simplified if the brightness of the source is uniform both as to position on the source as is to the angle of view. This has been the viewpoint in establishing Table 28, and hence equation (58) would be applied to the problem in question and the value of B

determined for the desired E_p , where E_p is the initial illumination. Equation (58), repeated, is

$$E_p = B \int_s \frac{\cos \alpha \cos \beta dA}{D^2} \quad (58)$$

If the value of B exceeds that permitted by the possibilities of glare, then another try must be made with a larger panel. In so doing the integral of equation (58) will change. Thus the problem may degenerate into a successive approximation process with the successive tries guided by the previous tries.

If the luminous elements are to provide general illumination to a room and are to be carried as ceiling elements, the three-curve-calculation method may be used instead of the direct-calculation method of equation (58), which neglects all interreflections.

Problems

1.12. A silhouette background is to be designed for an outdoor sign in a medium-brightness district in which there are other signs of a similar nature. The height of the background is to be 40 in. Pastel color is to be used in the background, and the reflection factor for incandescent light is 0.55. Show a cross section of the element drawn to a 1 in. to 1 ft. scale. Specify the size of incandescent, 115-volt lamps to be used, and indicate their spacing.

2.12. Half-cylinder recessed ceiling elements with troughs 10 in. wide are to be used to provide general illumination to a ballroom. The dimensions of the room are 50 by 130 ft. Three rows of nine elements each, each 55 in. wide and 10 ft. long, spaced 4 ft. apart longitudinally, are to be used the full length of the room. The average reflection factor of the walls is 0.15, and that of the ceiling is 0.75 (including the recesses). A variable range of illuminations for 0.5, 2, and 10 ft.-candles is desired. Show a cross section of the recess drawn to a 1 in. to 1 ft. scale. Specify the sizes of incandescent lamps to be used, and indicate their spacings and arrangements. The ceiling height is 15 ft.

REFERENCES

- E. W. Beggs and C. S. Woodside, Technical Aspects of Architectural Lighting, *Trans. Illum. Eng. Soc. (N.Y.)*, 1931, pp. 1007-1024.
 W. M. Potter and P. Meaker, Luminous Architectural Elements, *Trans. Illum. Eng. Soc. (N.Y.)*, 1931, pp. 1025-1051.
 "Illumination Design Data," General Electric Company, October, 1936.

CHAPTER 13

TESTING OF ILLUMINATION SYSTEMS BY SAMPLES AND MODELS

<i>Symbol</i>	<i>Term</i>	<i>Definition</i>
	Sample	A partial installation of equipment installed judiciously for testing.
	Model	A representation of an object constructed so that all component parts are in proportion.
	Image	A representation of an entity in fancied form.
<i>S</i>	Scale factor	A numeric representing the ratio of linear dimensions in the model to those in the corresponding original thing.

76. General.—The illumination received at a point on a receiver plane can be calculated theoretically only if the brightness distribution of every surface viewed by that point is known. If the luminaires within an interior room predominate in this calculation, the illumination at the point can be determined at least approximately (as has been discussed in Chap. 4) by utilizing the apparent candle-power-distribution curve of the luminaires. If the size of the luminaires is large with respect to the distances involved, or if other surfaces of sufficient brightness and area (such as luminous architectural elements or the walls and ceilings themselves) contribute significantly to the illumination at the point, then the integration process of Art. 17, or some approximation based upon the method, must be used. When all this has been accomplished, the illumination at *one* point on the working plane has been determined. If the illuminations at other points are desired, the process must be repeated for each point.

The three-curve calculation method (or lumen method) determines the *average* illumination upon the working plane and gives no information upon the illumination at any specific point in the room. Consequently, if maximum and minimum values of illumination are desired, this method is not sufficient.

In designing special luminous architectural elements certain calculations may be accomplished, but the final judgment upon

the suitability of the element may depend largely upon how the element fits into the architectural achievement as a whole as regards its size, proportions, and hue.

Consequently such desired results may often be obtained more rapidly and with better assurance of correctness by one of the following two methods.

a. Samples of the lighting equipment considered may be installed under the actual conditions for which they will be used. When this has been accomplished, measurements by special methods may be made from which the illumination distribution in certain parts of the room may be determined. Often of equal importance, the appearance of the equipment under actual conditions of use may be ascertained.

b. As an alternative to the sample method of testing, a model of the installation may be constructed and measurements made upon the installation in miniature.

Both of these methods are used rather extensively, but seldom are methods of testing formulated. The purpose of this chapter is to present such principles as seem applicable to these methods.

77. Testing by Samples.—The method to be described will apply principally to installations in large interiors in which the total completed installation would be much larger than the sample section. This will represent the most general condition, and modifications of the method can be devised to suit particular cases.

Suppose that several systems of illumination are being considered for a large office building. A trial installation into even one office room (which might measure 80 by 120 ft., for example) would be a rather ambitious undertaking. Instead, let a sample installation be made in just one bay of the room or, if the room is free of architectural obstructions, in any small section of the room. Obviously a survey under just this section would yield little useful information, since the cross lighting between bays would be missing.

The method of images is used rather extensively in other fields and can be applied here with equal usefulness. Suppose that the bay containing fixtures is shown as bay *E* in Fig. 115. The illumination at selected stations is determined by a survey in one quarter of the lighted bay *and also in certain adjacent bays or parts of bays*. The illumination readings in these adjacent

bays will be used, together with those in the lighted bay, to determine the equivalent illumination as though all bays in the whole vicinity were likewise lighted.

The illumination at the point *a* in bay *B* in the figure is the illumination at this point due to lighted fixtures in bay *E*. If bay *B* contained the lighted fixtures and bay *E* were unlighted, the illumination at the point 11 would be identical with that at *a* as measured under the conditions of the test.

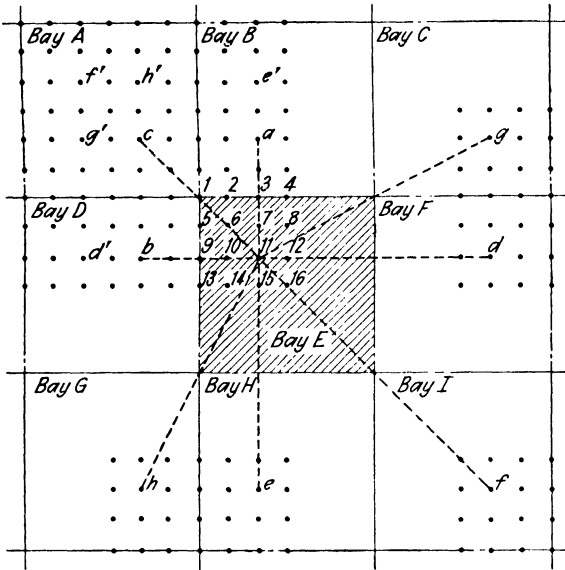

FIG. 115.—Method of images applied to sample installation of lighting equipment in bay *E*.

A similar procedure would apply regarding point *b* in bay *D*. Thus the sum of the readings at points *a*, *b*, and 11 under the conditions of the test represent the illumination that would exist at point 11 with bays *B*, *D*, and *E* all lighted in a similar manner as was *E* in the test.

Likewise in bay *A* a reading at *c* should be added to the previous readings to represent the additional illumination at 11 due to lights in bay *A*.

A reading at point *d* in bay *F* would interchange with point 11 in bay *E* and hence should be added to represent the contribution at 11 due to lights in bay *F*. However, the illumination at

point *d* in bay *F* and at point *d'* in bay *D* would be the same because of symmetry about the lighted bay. Hence the illumination can be determined by a reading at *d'* as well as at *d*. The same is true regarding points *e* and *e'* in bays *H* and *B*, respectively.

The contribution from bays *I*, *C*, and *G*, having readings at points *f*, *g*, and *h*, respectively, would be included by adding the corresponding readings at points *f'*, *g'*, and *h'* all in bay *A*.

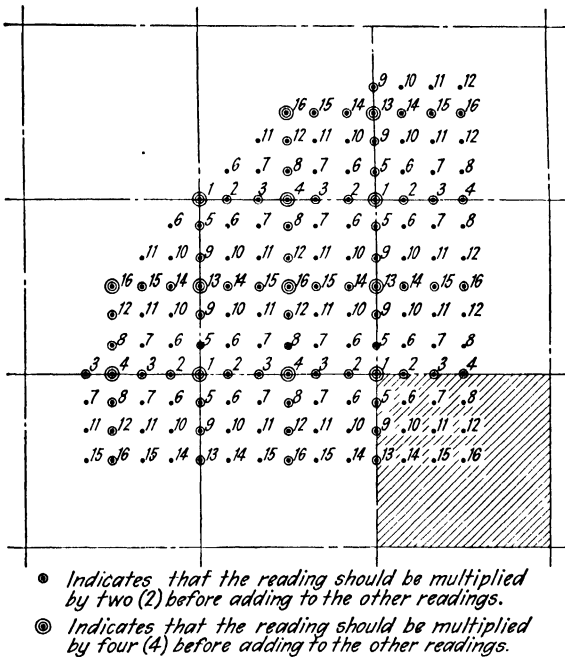

FIG. 116.—General plan of adding illuminations by the image method.

Because the points 1, 2, 3, 4, 5, 9, and 13 lie on a border line between two bays, it is apparent that readings contributing to the complete illumination at these particular points in the stations selected for the example must be multiplied by either two (2) or four (4) depending upon whether two fields adjoin each other or four fields fit together at a corner point.

The complete field extending out into the second bay away from the one lighted is illustrated in Fig. 116. This shows the general plan of adding the illuminations at the various points.

All points designated by a given number in this figure should be added together to yield the complete illumination at that point in the field. Theoretically the summation would be an infinite series were there no walls to the room. Actually the contribution from bays farther away than the second will generally be negligible except in very high-ceiling rooms with relatively small bays.

The illumination pattern resulting from the summation gives the illumination at the selected station points for a bay *not near the side walls*, since images have been brought in from all directions even though the readings are taken only in one quadrant with the center of the lighted bay as the origin. This fact should be appreciated in judging the equipment as regards the average illumination produced. In large rooms (rooms with large room indexes) the side walls, however, affect the average illumination very little, and it is for this type of room that the preceding sampling method has its most general application. Modifications of the method can be applied to other cases.

78. Testing by Models.—The reduction of large buildings, sections of buildings, or interiors to miniatures can be accomplished with reasonable cost. The illumination system, itself being to the same scale, can then be applied to the miniature, and the resulting illuminations determined.

A survey of the majority of literature published dealing with testing by miniature models will reveal that only seldom has an attempt been made to ascertain other than relative magnitudes of the results. No attempt will be made here to discuss the merits or demerits of various testing that has been accomplished. Rather the purpose will be to point out how quantitative results may be determined upon the basis of the fundamental relationships of illumination as discussed in Chap. 4.

In any illumination system always three and possibly four entities may be involved. Let the special case be considered first in which every part of the system, except the primary source of luminous flux, is nonselective spectrally. As an example consider a room that contains surfaces any region of which has spectral reflection factors over the range of wave length from 0.40 to 0.76μ of a constant value. Other regions may have different reflection factors, but spectrally every part will be nonselective. Subjectively one would say that the room

was decorated in shades of gray. Whatever be the spectral nature of the source of luminous flux, an investigation at a point on any surface in the room would reveal an illumination of exactly the same spectral nature as the source. This follows from a careful consideration of the fundamentals of Arts. 44 to 47.

A further restriction will be placed upon the surfaces of the room. None of the surfaces will be capable of emitting luminous flux when acted upon by irradiation outside the range of 0.40 to 0.76μ .

If these restrictions are valid for the system, then the elimination of the entity of spectral conditions, except as a constant invariant condition of the system, leaves the three remaining entities:

a. Conditions involving the magnitude of the sources of the system (the cause).

b. Conditions involving the magnitude of the illumination on surfaces of the system (the effect).

c. Conditions involving the three-dimensional physical properties of the system.

Entities classified under *c* are constants of the system with the foregoing restrictions in force and are independent of the cause-and-effect phenomena. This is not a necessary condition in order that the method of models may be used, but the resulting simplification to a consideration of magnitudes alone is rather desirable at first.

The specification of brightness of the primary sources of the system fixes the conditions listed under *a*. The conditions listed under *b* are in general those which are desired, and *c* has already been discussed for the special case being considered first.

The general equation relating these three entities as regards their magnitudes was given in equation (17), which is repeated below.

$$E_p = \int_S \frac{B}{D^2} \cos \beta \cos \alpha dA \quad (17)$$

When a miniature model is used for testing, certain parts of the equation will be affected directly by a linear scale factor S . Obviously such parts will all specify dimensions, either of the enclosure itself or of any physical parts within the enclosure,

such as the luminous sources and representations of any furniture, desks, carpeting, or similar furnishings.

Since both the illumination E_p and the brightness B in equation (17) are specifications at *points* on the receiver and source planes, respectively, no scale factor should be applied to these entities. The cosine functions are dimensionless factors and hence should likewise receive no scale factor. dA and D^2 would, however, both receive scale factors of S^2 , since they are specifications of area or (length)². When such factors have been inserted, they will immediately cancel, since dA and D^2 are reciprocal parts of the equation.

Thus the conclusion can be drawn that the cause-and-effect phenomena between any pair of points on a source and a receiver plane are independent of scale of the model when cause is specified through brightness. Illuminations may be interpreted directly once the brightness conditions of the model sources are known with respect to those of the actual sources.

However, if luminaires are used in the system and the cause phenomena are expressed as apparent intensities of the source as a whole entity even in its miniature form, then the equation relating the apparent intensity of the source and the illumination received directly from the source at a point on a receiver plane must be studied. This is equation (8a) of Chap. 4.

$$E_p = \frac{I}{D^2} \cos \beta \quad (8a)$$

The dimensional factor of S^2 is already included in the apparent intensity as determined for the miniature luminaire. In building the model a scale factor was chosen such that

$$D' = SD \quad (113)$$

where D = distance in the full-size (actual) system.

D' = corresponding distance in the model.

S = scale factor (a numeric less than unity for a miniature model).

If I' is the apparent intensity of the miniature model luminaire and E_p' is the illumination in the model, then

$$E_p' = \frac{I'}{(D')^2} \cos \beta \quad (114)$$

If the variables without the primes indicate the true conditions to be determined, then dividing one equation by the other and

inserting the relationship of equation (113) gives

$$\frac{E_p}{E_p'} = S^2 \frac{I}{I'} \quad (115)$$

or

$$E_p = S^2 \left(\frac{I}{I'} \right) E_p' \quad (115a)$$

If in building the model, care is taken that the apparent intensities of the model luminaires are decreased as the square of the scale factor, then the illumination conditions as tested will represent the actual illumination conditions of the full-size system. Otherwise the ratio of intensities as indicated in equation (115) must be multiplied by the square of the scale factor.

When a study has been made of the relations of cause-and-effect magnitudes in scale models with strictly constant dimensional and reflecting conditions, the method can be expanded to include even a variation of spectral conditions at any one of innumerable positions in the room if each position in the full-size room is matched by identical positions (with due regard to scale) in the miniature model.

The cause-and-effect phenomena that have been studied in the special case above can be considered between any pair of points in the model and the corresponding points in the full-size room. Since each phase of this microscopic examination may be matched between the two, it is obvious that the relationships regarding the magnitudes of the individual cause-and-effect phenomena will likewise hold for the ensemble as a whole.

The application has been made to interiors. The same facts can be applied to any type of investigation in the illumination system. One of the most thorough studies on highway-illumination fundamentals was conducted upon a model built at a one-eighth scale factor.

Problems

1.13. A sample installation of four fluorescent luminaires, rated at 200 watts each (four 40-watt "white" lamps with auxiliaries), in one bay of a large room yielded the results shown in Fig. 117. The ceiling height of the room was 10 ft., and each bay was 18 by 16 ft. At the corner of each bay was a column 24 in. square, which greatly reduced the lighting into adjacent diagonal bays as is indicated in the data. (a) Determine the illumination

at the stations selected in one quarter of one bay for all bays in the vicinity also lighted in a similar manner. (b) Draw an illumination contour map of the quadrant for increments of illumination of 5 ft.-candles. (c) Using a planimeter, determine the areas between adjacent contour lines. Multiply these respective areas by the mean illuminations of the areas. What is the average illumination by this method? (d) Compare the results of (c) to the average illumination determined by the average of the data points of (a).

2.13. A model of a football field and its illumination system is constructed to a 1/50 scale. Two floodlights of different distribution are being con-

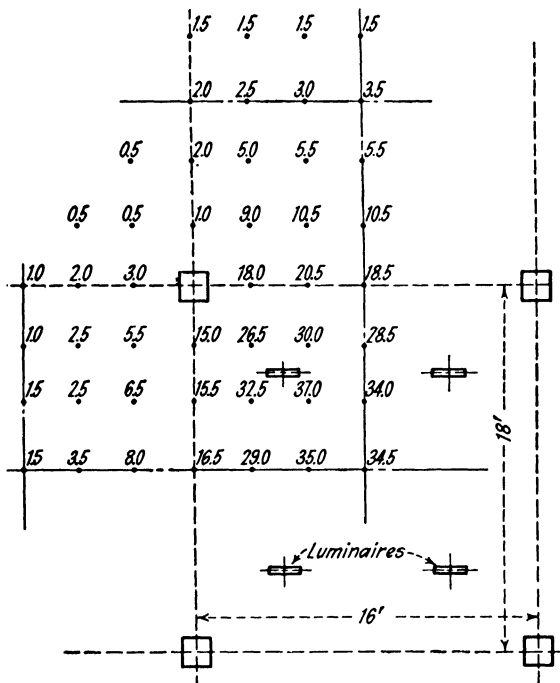

FIG. 117.

sidered for the actual installation. One of these, designated as *A*, is represented in miniature so that the relative distribution matches the original exactly but the magnitude of all its apparent intensities taken at 2 ft. are 1/1000 as large as the full size unit when taken at 100 ft. The second unit, designated as *B*, likewise possesses proper relative values, but in it the apparent intensities at the same respective distances are in the ratio of 1/1500. A measurement of the illumination at a specified point on the miniature playing field with an installation of miniature sources of type *A* gives 23 ft.-candles. A measurement using type *B* gives 19 ft.-candles on the model at the same position. What will be the illumination in the full-size installation in each case?

CHAPTER 14

DESIGN OF FLOODLIGHTING SYSTEMS

<i>Symbol</i>	<i>Term</i>	<i>Definition</i>
ϕ_B	Beam lumens	The luminous flux within such a solid angle from the source that the apparent candle power of the source is not less than 10 per cent of the maximum beam candle power.
	Floodlight lamps	Lamps having concentrated filaments, generally used in narrow-angle floodlights.
	Setback construction	A type of skyscraper building construction in which at various elevations above the street level the floor area of the successively higher levels is decreased.

79. General.—The nighttime lighting of exterior areas serves many useful purposes. Such lighting extends into the fields of advertising and recreational pursuits as well as into the purely utilitarian fields such as the lighting of railway and industrial yards, parking areas, and similar locations. The application of the term *floodlighting* to such uses is generally an erroneous procedure, since the efficient lighting of areas from relatively large distances requires equipment possessing rather restricted distributions of luminous flux rather than a “flooding” distribution. However, regardless of the spread of the beam, the term floodlighting has been adopted by common usage and so will be used here.

80. Beam Spread.—The specification of the manner in which the luminous flux is emitted by the floodlighting unit is generally stated in terms of the angle of the beam. If the unit is not symmetric about a central axis, two angles may be specified—one measured perpendicular to the other.

The angle (or angles) so specified is the *total* angle of the beam in that direction and not simply that from the central axis outward. The angle is considered as extending between such values that the beam candle power is decreased to 10 per cent of the maximum beam candle power as determined at some specified distance (generally 100 ft. or more if the beam angle

is small). Light emitted in zones outside this angle is usually disregarded, since it is seldom of any use except where the relative ratio of the area to be lighted to the distance from the source to the area is large.

The characteristics of the beam are determined by the design of the reflector contour and of the lens system (if such is used), together with the size and position of the primary source. A floodlighting unit may have a minimum beam divergence with a high beam candle power or a greater beam divergence with more luminous flux in the beam. Generally high efficiency and narrow beam spread are conflicting conditions, and usually one is obtained at the expense of the other.

81. Location of Equipment.—The location of equipment is usually determined through a coordinated study of the physical surroundings, the desired lighting effects, and the equipment available and its characteristics.

Small buildings of simple architectural treatment are generally most effectively displayed when illuminated rather uniformly. The floodlights may be placed on roofs of other buildings or on curb posts. The distance from the building to the floodlight should generally be not more than 200 ft., and the lights should be so located that the incident light is received nearly perpendicular.

Larger buildings with setback features and towers lend themselves to nonuniform illumination. Units should be located just inside the parapets and enough above the floor level of the setback to prevent immersion in rain water or snow but at such elevation as to shield the units from external view.

Floodlighting of monuments must be accomplished with the light sources in such positions as to produce natural shadows on the statuary. Usually this requires that the light come from above the horizontal and often from several angles.

When ground surfaces are to be floodlighted, the equipment is generally located on poles or on the roofs of adjacent buildings. In general the floodlights should be located as high as possible in order to reduce glare. Recommended mounting heights are listed in some of the tables that follow.

82. Types of Equipment.—Floodlights may be classified generally into one of two types—enclosed units and open units.

The enclosed-type unit consists essentially of a reflector and a lamp source mounted in a metal housing and covered with either

a glass cover plate or a lens. The reflector materials most commonly employed are silvered glass, chromium plate, and polished aluminum, with the silvered glass used in the majority of the enclosed-type units.

The open-type unit is generally less expensive and is suitable only for broad-angle projection. The reflector, usually made of porcelain enameled steel, aluminum, or chromium plate, acts to direct the light in a broad beam and also prevents rain or snow from reaching the lamp bulb. Obviously the open-type unit is suitable only when the light is to be projected horizontally or downward, since the reflector as a whole cannot safely be tilted upward.

The advantages of the enclosed type of unit are (a) more accurate control of the beam; (b) more permanence in construction; and (c) a higher maintenance factor, since the reflecting surfaces are protected from dust and dirt.

The advantages of the open-type unit are (a) low initial cost and (b) light weight. The latter factor reduces the size and hence the cost of poles and brackets used in mounting the units.

83. Levels of Illumination.—The illumination required for the particular application depends greatly upon the seeing tasks involved and upon the surrounding conditions. The previous discussion concerning illumination standards in Chap. 10 applies equally well here.

For tabulation purposes the illumination levels for good practice are represented in several parts. The principle applications, excluding building and monument floodlighting and recreational lighting, are presented in Table 29. Recommendations for various recreational lighting applications are covered in the discussion and figures that follow in Art. 85. Recommendations for floodlighting buildings and monuments are given in Table 30.

84. Calculations for Floodlighting.—Various means of arriving at the number of floodlighting units to be used and the size of lamps to be used therein have been established. Most of these methods are some form of the "lumens in the beam" method or modification of it to suit particular requirements.

If the area to be floodlighted and the average illumination to be obtained are known, then the product of these values gives the total number of lumens of luminous flux that must be received by the surface. If the positioning and directing of the

TABLE 29.—RECOMMENDED STANDARDS OF ILLUMINATION
FOR OUTDOOR LIGHTING*

	Foot-candles
Automobile parking spaces.....	1
Bulletin and poster boards:	
Bright Surroundings:	
Light surfaces.....	50
Dark surfaces.....	100
Dark surroundings:	
Light surfaces.....	20
Dark surfaces.....	50
Buildings:	
Construction work.....	5
Excavation.....	2
Circus:	
Seats.....	2
Arenas.....	10
Featured attractions.....	50-100
Coal Yards—protective.....	2
Dredging.....	2
Drill fields.....	5
Flags—floodlighted.....	30-50
Gasoline filling stations:	
At pumps.....	20
Yard and driveways.....	5
Loading docks and platforms.....	5
Lumber yards.....	1
Motordromes:	
Seats.....	2
Track.....	20
Piers:	
Freight.....	5
Passenger.....	5
Prison yards.....	5
Protective industrial.....	2
Quarries.....	2
Railroad yards:	
Receiving.....	0.1
Classification.....	0.2
Shipyards construction.....	5
Smokestacks.....	15
Storage yards.....	1
Waterfalls.....	10
Water tanks.....	15

* From Westinghouse "Illumination Design Handbook," 1936, and "Illumination Design Data," General Electric Company, 1936.

projectors with due respect to the beam spread has been accomplished properly, then the total lumens received at the surface divided by the lumens in the beam give the number of projecting units needed. A maintenance factor of 0.70 is generally included as in equation (116),

$$N = \frac{A_T \times E}{0.7 \times \phi_B} \tag{116}$$

where N = number of floodlighting units.

A_T = area to be lighted.

E = average illumination desired.

ϕ_B = lumens of flux in the beam.

TABLE 30.—FOOT-CANDLE RECOMMENDATIONS FOR FLOODLIGHTING BUILDINGS AND MONUMENTS^a

Representative building materials	Approximate reflection factors, per cent	Foot-candles for downtown ^b buildings in cities of		
		Over 50,000	50,000 to 5,000	Under 5,000
White terra cotta.....	75	15	10	5
Cream terra cotta.....				
Light marble.....				
Light gray limestone.....	50	20	15	10
Bedford limestone.....				
Buff limestone.....				
Smooth buff face brick.....				
Briar hill sandstone.....	35	30	20	15
Smooth gray brick.....				
Medium-gray limestone.....				
Common tan brick.....				
Dark field-gray brick.....	20	50	30	20
Common red brick.....				
Brownstone.....				

^a From "Illumination Design Data," General Electric Company, 1936.

^b For buildings in outlying districts use the foot-candles recommended for downtown buildings in cities of the next smaller classification.

NOTE: Buildings composed of material having a reflection factor much below 20 per cent cannot economically be floodlighted unless there is a large amount of light trim.

The method seems simple in application, but selection of the floodlighting unit itself often cannot be made until the number of lumens of flux in the beam is fixed and until the geometric positioning of the unit and the portion of the total area to be covered by each unit have been definitely determined. Also in applications to uniform illumination the beam spread of the unit selected must be coordinated with the area to be lighted. In applications to nonuniform illuminations the average illumination E in equation (116) may have practically no meaning where the point-by-point values of illumination may be more important than the average. Hence equation (116) is generally useful only in arriving at a first approximation of the number of units if certain values of ϕ_B are available. From this start, then, the system can be designed by a successive trial and error method.

The selection of the type of unit for the first approximation must be governed by familiarity with what is reasonable. To apply an extremely small beam-spread unit to floodlighting a relatively large area from a reasonably small distance is obviously not economical, since an enormous number of small units would result. Conversely, the beam spread of a single unit should not at the most be appreciably greater than that required to cover the total area; or light spill will reduce the average illumination on the area of interest.

Table 31 is useful in arriving at this first approximation step for several applications.

Table 32 gives the beam lumens, ϕ_B in equation (116), for typical floodlighting units. The catalogue data on the beam spreads and beam lumens for the particular units to be actually chosen later should be consulted at that stage in the design. However, the values given in the foregoing table are sufficiently accurate for the first approximation. Projectors employing "floodlight" lamps generally have high beam efficiencies. However, the "general service" lamps cost less, have a longer rated life, and can be burned in any position. For a beam spread greater than about 15 deg. there is no particular advantage in an extremely concentrated light source such as the floodlight lamps, and hence the general service lamp would normally be chosen.

Having arrived at several possibilities of the number of floodlighting units of some general classification as to beam angle (or angles), catalogue data on units of this type should be

TABLE 31.—A GUIDE TO THE SELECTION OF THE PROPER BEAM SPREAD^a

Representative floodlighting applications	Usual distance away, ft.	Proper beam spread
Buildings two or three stories high, lighted from marquees or posts at curb.....	10- 30	Broad
Buildings lighted from across street or some distance away:		
Areas less than 3,000 sq. ft.....	50-100	Medium
Areas more than 3,000 sq. ft.....	50-100	Broad
Areas less than 3,000 sq. ft.....	100-150	Narrow
Areas more than 3,000 sq. ft.....	100-150	Medium
Areas less than 10,000 sq. ft.....	150-300	Narrow
Areas more than 10,000 sq. ft.....	150-300	Medium
Buildings of the setback type:		
Setbacks one or two stories high.....	On building	Broad or medium
Setbacks three or more stories high....	On building	Medium or narrow
Columns and ornaments.....	2- 10	Narrow
Construction work, parking spaces, gasoline stations, etc.....	At edge	Broad
Football stadiums.....	50-100	Medium

^a From "Floodlighting," General Electric Company, 1931.

consulted. With the project laid out to scale the manner of aiming and spacing of the projectors should then be determined. Since probably only a few of the projectors may be lighting the surface with their light received perpendicular, great care must be taken in the selection of lamp sizes, beam spreads, and degree of overlapping of light from the several projectors if the surface is to be illuminated reasonably uniformly. It is at this point in the design that the trial-and-error system may become laborious. Tables of average coverage areas, classified as to the beam spread and the position of the total area to be lighted with respect to the projectors, are very convenient in facilitating this step. The data apply whether the lighted area is vertical or horizontal.

Table 33 presents these data for various angles of beam spread. The value of D in the table is the distance from the projector to the plane of the lighted surface or area, measured perpendicular to the surface, as illustrated in Fig. 118 for a vertical surface. The distance Z in the table determines the average angle of

TABLE 32.—BEAM LUMENS OF TYPICAL FLOODLIGHTING UNITS^a

Beam spread	Projectors designed for floodlight lamps ^b		Projectors designed for general service lamps			
	Lamp size, watts	Average beam lumens	Lamp size, watts	Average beam lumens		
				Reflector diameter 12 to 16 in.	Reflector diameter 18 to 24 in. ^c	
Narrow (15 deg. and less)	250	1100	300	1400		
			500	2500		
	500	2600	750		5500
			1000		7800
		1500	10,500		
Medium (16–29 deg.)	250	1150	300	1700		
			500	3000		
	500	2800	750	4900		6000
			1000	7000		8500
		1500	12,500		
Broad (30 deg. and over)	250	1200	300	1900		
			500	3400		
	500	2900	750	5200		6200
			1000	7400		8800
		1500	13,000		

^a From "Floodlighting," General Electric Company, 1931.

^b These lamps have concentrated filaments and can be burned in any position except within 45 deg. of the vertical, base up.

^c These large units are recommended for long throws or where the installation will be kept in operation for at least five years or where there are unusually severe operating conditions.

throw and consequently determines the average area covered by each projector. One of two conditions will always apply:

a. If a perpendicular from the plane of the lighted surface to the projector falls *within* the total area to be lighted, Z is one-half the distance from the base of the perpendicular to the farthest edge of the surface to be lighted. This is the condition shown as (a) in Fig. 118.

b. If the perpendicular from the plane of the lighted surface to the projector falls *outside* the total area to be lighted, Z is the distance from the base of the perpendicular to the mid-point

of the total area to be lighted. This is the condition shown as (b) in Fig. 18.

The value of A_E is the average area lighted effectively by each projector, corrected to allow for overlapping of the beams to a degree to ensure reasonable uniformity.

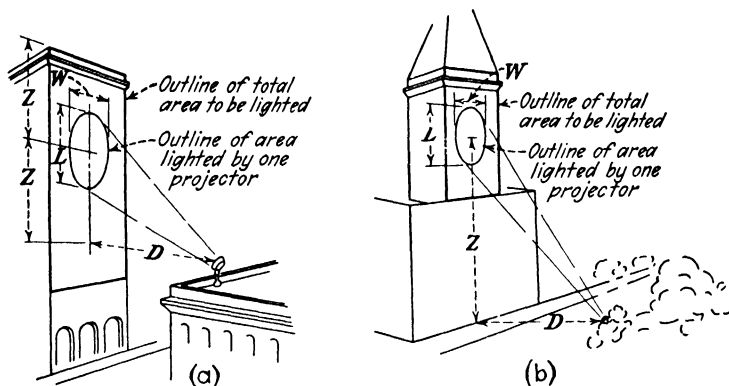

FIG. 118. —Explanation of terms in Table 33.

These values are sufficient to determine the number of projectors necessary to give uniformity in the coverage. The number of projectors necessary obviously is

$$N' = \frac{A_T}{A_E} \quad (117)$$

where N' = number of projectors necessary for reasonably uniform coverage.

A_T = total area of lighted surface.

A_E = average area lighted effectively by each projector from Table 33.

The values of L and W from the table give the actual length and width of the ellipse lighted by each projector if Z is taken as the actual distance from the center of the ellipse to the perpendicular point regardless of the area to be lighted. These values are not used in the design procedure at this stage but are useful in laying out the beam patterns over the entire area later.

If the number of projectors obtained from equation (117) is smaller than or at most equal to the number obtained from equation (116), then the value obtained from equation (116)

TABLE 33.—SPOT SIZES—DIMENSIONS AND AREAS*
 (Average effective coverage for various beam spreads and locations of projectors. All distances in feet.)

10-deg. beam-spread projector					15-deg. beam-spread projector				
D	Z	A _F	L	W	D	Z	A _F	L	W
15	0	5	3	3	15	0	10	4	4
	10	8	4	3		10	20	6	5
	20	21	7	4		20	50	11	7
	30	52	14	6		30	130	21	9
	40	113	22	8		40	290	37	12
25	0	11	4	4	25	0	25	7	7
	20	23	7	5		20	50	11	8
	40	71	16	8		40	170	25	13
	60	195	31	11		60	490	49	18
	80	450	54	15		80	1200	90	24
50	0	38	9	9	50	0	90	13	13
	20	47	11	9		20	110	15	14
	40	81	14	11		40	190	22	17
	60	150	22	14		60	340	33	20
	80	260	32	17		80	600	49	25
75	0	67	13	13	75	0	170	20	20
	40	110	17	14		40	250	25	22
	80	220	28	18		80	540	43	29
	120	530	48	25		120	1210	74	38
	160	1040	76	32		160	2500	119	49
100	0	120	17	17	100	0	310	26	26
	40	150	20	19		40	390	31	28
	80	250	29	22		80	580	44	34
	120	470	43	28		120	890	66	41
	160	830	63	33		160	1950	98	51
150	0	270	26	26	150	0	610	39	39
	40	300	28	27		40	680	42	41
	80	400	34	30		80	900	51	45
	120	570	43	34		120	1310	65	51
	160	860	57	39		160	1970	86	58
200	0	480	35	35	200	0	1090	53	53
	40	510	37	36		40	1160	55	54
	80	600	41	38		80	1360	61	57
	120	770	48	41		120	1730	72	61
	160	1030	58	45		160	2330	87	68
300	0	1080	52	52	300	0	2460	79	79
	40	1110	53	53		40	2520	80	80
	80	1200	56	54		80	2720	85	82
	120	1350	61	57		120	3070	92	85
	160	1580	68	60		160	3590	102	90
500	0	3010	87	87	500	0	6810	132	132
	40	3030	88	88		40	6870	133	132
	80	3120	90	89		80	7070	135	133
	120	3270	93	90		120	7410	139	135
	160	3490	97	92		160	7900	145	138

* From "Illumination Design Data," General Electric Company, 1936.

TABLE 33.—SPOT SIZES—DIMENSIONS AND AREAS.^a—(Continued)

20-deg. beam-spread projector					25-deg. beam-spread projector				
D	Z	A _B	L	W	D	Z	A _B	L	W
15	0	18	5	5	15	0	30	7	7
	10	33	8	7		10	50	10	8
	20	93	16	9		20	160	20	12
	30	250	30	13		30	460	41	17
	40	620	55	17		40	1300	83	23
25	0	44	9	9	25	0	70	11	11
	20	100	15	12		20	150	19	14
	40	330	34	17		40	540	45	22
	60	1030	73	25		60	1960	105	34
	80	2920	145	36		80	7270	251	53
50	0	155	18	18	50	0	210	20	20
	20	195	21	19		20	320	26	24
	40	330	30	23		40	550	38	29
	60	630	45	28		60	1070	58	36
	80	1160	68	35		80	2060	90	45
75	0	310	26	26	75	0	480	33	33
	40	440	34	30		40	710	43	38
	80	1010	59	39		80	1630	75	50
	120	2320	102	52		120	3930	135	67
	160	5050	171	67		160	9060	238	88
100	0	490	35	35	100	0	770	44	44
	40	610	41	38		40	980	52	48
	80	1050	59	46		80	1700	75	58
	120	2000	90	56		120	3290	116	72
	160	3700	136	69		160	6340	180	89
150	0	1100	53	53	150	0	1740	67	67
	40	1230	57	55		40	1940	71	69
	80	1630	69	60		80	2580	87	76
	120	2380	89	68		120	3820	113	87
	160	3610	117	79		160	5920	151	100
200	0	1940	71	71	200	0	3090	89	89
	40	2080	73	72		40	3280	92	91
	80	2470	82	77		80	3910	104	96
	120	3160	97	83		120	5030	123	104
	160	4240	118	91		160	6800	150	115
300	0	4400	106	106	300	0	6940	133	133
	40	4520	108	107		40	7140	136	134
	80	4890	114	110		80	7740	143	138
	120	5530	123	114		120	8790	156	144
	160	6480	137	120		160	10,300	173	152
500	0	12,200	176	176	500	0	19,300	222	222
	40	12,300	177	177		40	19,500	223	222
	80	12,700	181	179		80	20,100	228	225
	120	13,300	187	181		120	21,100	235	228
	160	14,200	195	185		160	22,500	246	233

^a From "Illumination Design Data," General Electric Company, 1936.

TABLE 33.—SPOT SIZES—DIMENSIONS AND AREAS.^a—(Continued)

30-deg. beam-spread projector					35-deg. beam-spread projector				
D	Z	A _R	L	W	D	Z	A _R	L	W
15	0	45	8	8	15	0	60	9	9
	10	80	12	10		10	110	14	12
	20	240	26	14		20	360	32	17
	30	790	56	21		30	1430	79	27
	40	2900	133	33		40	8690	262	50
25	0	100	13	13	25	0	140	16	16
	10	140	16	15		10	170	19	17
	20	220	23	18		20	310	28	20
	30	430	36	21		30	660	45	27
	40	920	59	28		40	1430	75	34
	50	1930	94	37		50	3270	131	45
60	3950	155	46	60	8590	249	63		
50	0	350	27	27	50	0	510	32	32
	20	450	33	29		20	650	37	34
	40	800	46	35		40	1160	55	41
	60	1590	73	44		60	2440	90	53
	80	3200	117	56		80	5300	151	69
75	0	700	40	40	75	0	970	47	47
	20	790	43	42		20	1070	51	49
	40	1060	53	46		40	1460	63	54
	60	1590	69	53		60	2200	83	61
	80	2480	93	61		80	3620	114	73
	100	4000	128	72		100	5780	160	84
	120	6400	175	84		120	10,100	226	103
100	0	1130	54	54	100	0	1560	63	63
	40	1430	63	58		40	1980	74	68
	80	2550	92	70		80	3560	110	82
	120	5050	146	89		120	7510	180	106
	160	10,300	234	112					
125	0	1760	67	67	125	0	2440	79	79
	40	2130	73	71		40	2870	88	83
	80	3090	97	80		80	4350	116	96
	120	5200	138	96		120	7430	167	113
	160	9140	200	116					
150	0	2540	80	80	150	0	3510	95	95
	40	2880	86	85		40	3900	102	97
	80	3820	105	92		80	5300	125	108
	120	5700	135	107		120	8000	166	123
	160	10,300	234	112					
200	0	4500	107	107	200	0	6250	126	126
	40	4800	111	109		40	6660	132	129
	80	5700	125	116		80	7950	149	136
	120	7500	150	127		120	10,300	178	148
	160	10,200	184	141					

^a From "Illumination Design Data," General Electric Company, 1936.

TABLE 33.—SPOT SIZES—DIMENSIONS AND AREAS.^a—(Continued)

40-deg. beam-spread projector					50-deg. beam-spread projector				
D	Z	A [#]	L	W	D	Z	A [#]	L	W
15	0	80	11	11	15	0	130	14	14
	5	110	13	12		5	175	17	16
	10	150	17	14		10	260	22	18
	15	310	25	19		15	530	33	25
	20	630	43	23		20	1250	63	30
25	0	185	18	18	25	0	305	23	23
	10	240	22	20		10	400	28	26
	20	450	33	24		20	800	44	32
	30	970	55	32		30	2050	83	44
	40	2300	98	42		40	6950	187	66
35	0	320	26	26	35	0	520	33	32
	10	380	28	27		10	580	37	33
	20	510	35	32		20	890	47	39
	30	850	49	35		30	1550	67	47
	40	1490	71	43		40	3000	105	59
45	0	470	33	33	45	0	780	42	42
	10	520	35	34		10	820	44	42
	20	650	40	37		20	1070	52	47
	30	890	49	42		30	1550	67	53
	40	1320	66	46		40	2460	91	62
55	0	640	40	40	55	0	1030	51	51
	20	790	46	44		20	1300	59	56
	40	1320	66	51		40	2330	88	68
	60	2850	104	65		60	5250	152	88
	80	5600	172	83					
70	0	1020	51	51	70	0	1680	65	65
	20	1180	55	54		20	1940	72	69
	40	1680	71	60		40	2860	93	78
	60	2700	98	70		60	5000	135	94
	80	4700	142	84					
85	0	1500	62	62	85	0	2460	79	79
	20	1680	67	64		20	2750	85	82
	40	2130	78	69		40	3600	102	90
	60	3080	100	78		60	5400	133	103
	80	4750	132	92					
100	0	2100	73	73	100	0	3400	93	93
	20	2280	78	74		20	3700	98	96
	40	2700	86	79		40	4500	112	102
	60	3500	104	87		60	7800	138	113
	80	5000	130	98					
	100	7300	168	110					

^a From "Illumination Design Data," General Electric Company, 1936.

will satisfy the conditions of uniformity of illumination. If the number obtained from equation (117) is greater than that from equation (116), then the choice of another floodlighting unit must be made to satisfy the conditions of both relationships. The new design should employ either projectors of wider beam spread or more projectors with smaller lamps.

When a satisfactory adjustment has been accomplished (if such is necessary after the first trial), a layout of the area should be made with the actual beam spreads in both dimensions projected on the surface to be lighted. If certain of the projectors cover larger areas at greater distances than others, the aiming should be so adjusted for overlapping that more overlapping occurs in these areas. This condition results when either Z or the dimension parallel to W is large with respect to D . If either is the case, a relocation of a portion of the projectors may be desirable. The total area to be lighted may then be broken into as many parts as there are positions of projectors, and each considered separately. The increased cost of mounting the projectors at many locations must be balanced against the possible increase in uniformity. The values of Z given in Table 33 for each respective beam spread and value of D generally will be found reasonably limited in this respect.

85. Setback Floodlighting Design.—The methods of calculation previously discussed fail when the value of D is relatively small with respect to Z . This is the condition existing in floodlighting of large buildings from setbacks at various levels of the building. The spread of the upper portions of the beam is quite large with respect to the spread at its lower portions. Hence for a symmetrical beam the illumination at the upper regions would be very much less than that closer to the projector.

A knowledge of the distribution of the luminous flux in the beam becomes extremely important if beams for several projectors are to be combined to give desired effects of illumination. Tests have been made upon many projectors as used for floodlighting service. The average results of these tests are shown in Fig. 119. Both horizontal and vertical angles are shown divided into four equal parts. This divides the beam into 16 sections. The percentage of beam lumens in each of these sections is shown in the figure. Under extreme conditions of

uniformity the percentage of flux in sections 6, 7, 10, and 11 may be as small as 10 per cent, with this reduction made up by increased flux in sections 2, 3, 14, and 15.

The side elevation in Fig. 120 shows a projector mounted on the parapet on a setback at a distance D from the building with the beam so adjusted that its axis makes an angle of θ with the vertical. The points $C, D, E, F,$ and G represent the respective levels of the same points of the beam cross section shown in Fig. 119.

The front elevation in Fig. 120 shows the horizontal distribution of the beam having a horizontal spread of H degrees. The

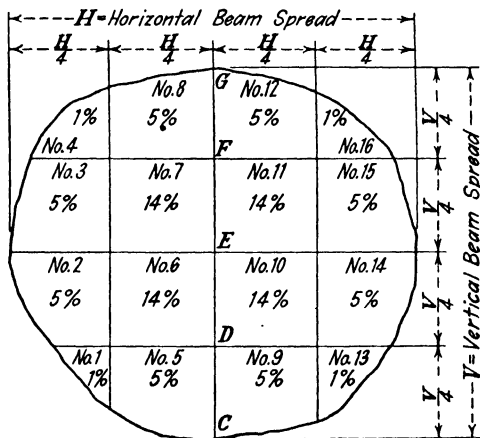

FIG. 119.—Distribution of luminous flux in percentage of total beam lumens.

beam as incident upon the building is shown divided into the same areas as in Fig. 119.

For assumed positioning of the unit, the pattern covered by each section of the beam can be laid out to scale. The sections can then be measured by some convenient method such as by a planimeter. Knowing the beam lumens within the sections, one can determine the resulting average illumination over each section.

The combination of beams of several characteristics may be desirable in accomplishing specified degrees of graduated illuminations of each section of a building between setbacks. Non-symmetrical projectors may also be used which place more

lumens in the beam sections 4, 8, 12, 16, and smaller amounts in the respectively lower sections of the beam. If such projectors are employed, a knowledge of how the luminous flux is distributed

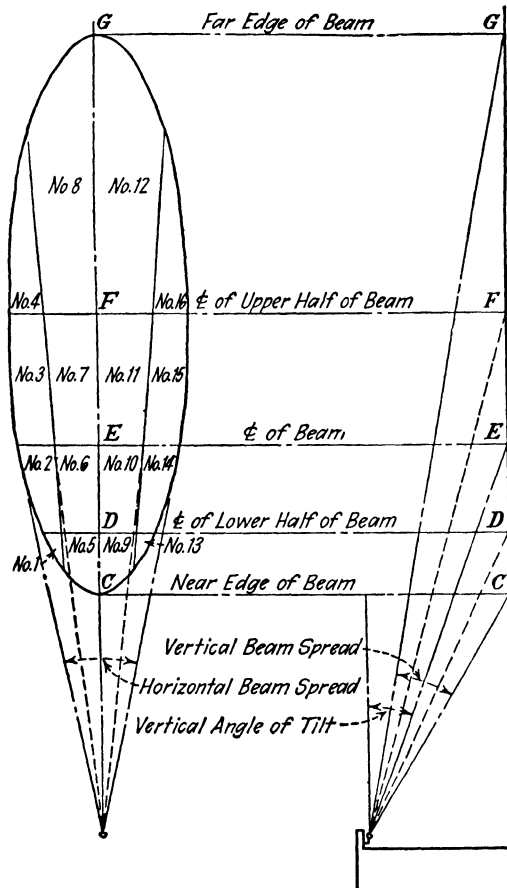

FIG. 120.—Beam outline on illuminated surface.

must be acquired before the design of spacings and aimings can be completed.

86. Recreational Lighting.—The methods previously described may be applied in lighting recreational sports areas as well as for the lighting of other areas. However, many designs have been established for many of the more popular sports, and

certain combinations of equipment have been found to give very good results. The arrangement of units and recommendations as to the number and size of projectors are included in the following figures for some of these sports.

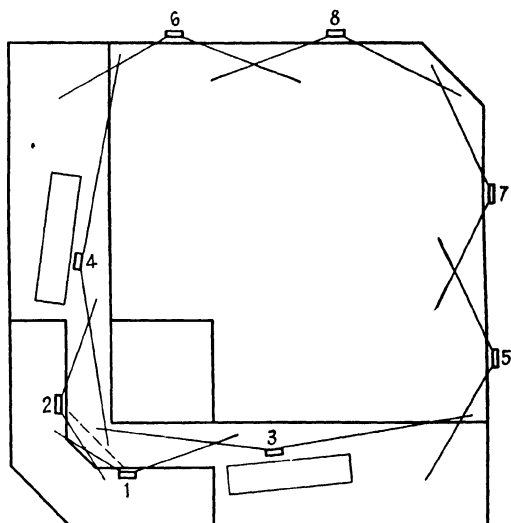

FIG. 121.—Floodlighting of baseball fields.

a. *Baseball.*—The location of groups of floodlighting banks is shown in the accompanying figure. Approximately 10 per cent of the lights should be placed on each of the positions 1, 2, 5, 6, 7, and 8, with 20 per cent on each of the positions 3 and 4.

TABLE 34.—RECOMMENDATIONS FOR BASEBALL LIGHTING

Class	Load at normal voltage, kilowatts	Mounting height, ft.
Major league.....	750-1000	{ Open units—100 (minimum) { Enclosed units—120 (minimum)
AA.....	400- 600	
A and B.....	200- 350	{ Open units—100 (minimum) { Enclosed units—120 (minimum)
C and D.....	175- 250	
Semi-pro.....	100- 150	80-90 70-80 60-70

Acceptable installations result when they conform to the recommendations of Table 34.

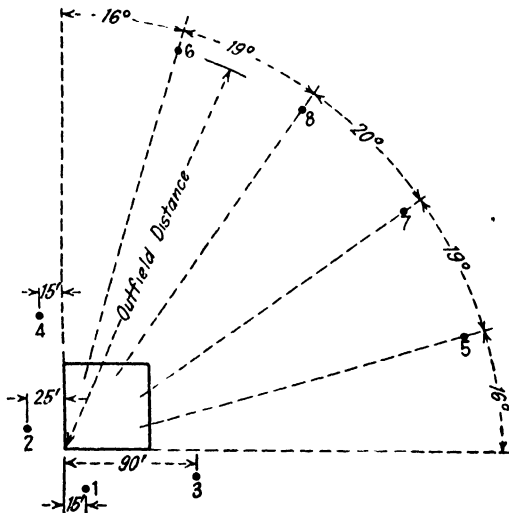

FIG. 122.—Floodlighting of Class A softball fields.

b. Softball.—The size of the audience, the size of the field, and the skill of the players are the principal factors that govern the

TABLE 35.—RECOMMENDATIONS FOR SOFTBALL LIGHTING

Distance from home plate to outfield, ft.	Number of 1500-watt lamps on each pole			Total kilowatts at rated voltage
	Poles 1 and 2	Poles 3 and 4	Poles 5 to 8	
Class A (8 poles)				
150	2	3	2	27
150-200	2	4	3	36
200-240	3	5	5	54
240-280	4	8	6	72
Class B (6 poles)				
150	2	2	3	21
150-200	2	3	4	27
200-240	2	4	5	33
240-280	3	6	6	45

illumination requirements for softball. Open-type reflectors with 1500-watt general service lamps are generally used. Units on infield posts should be mounted not less than 40 ft. high. Outfield units should be 40 to 60 ft. above ground depending on distance from home plate. Figure 122 illustrates the 8-pole field mounting system. Only 2 poles may be used at the outfield boundary, as indicated in class *B* in Table 35, each located 26 deg. from the first- and third-base lines.

c. Football.—Floodlighting units may be installed on poles erected on each side of the field rather close to the side lines or may be mounted behind the spectators at a greater distance from the field. When the distance from the side lines to the projectors is more than 30 ft., enclosed types of units should be used. Otherwise open-type

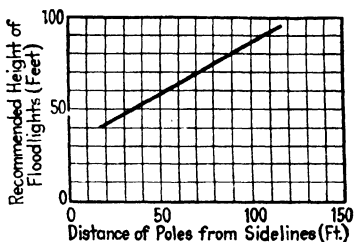

FIG. 123.—Recommended mounting heights for football floodlighting units.

TABLE 36.—RECOMMENDATIONS FOR FOOTBALL LIGHTING

Classification	Distance of poles from side lines of field, ft.	Total number of 1500-watt floodlights	Total number of poles (one-half on each side)	Lights per pole	Total kilowatts at rated voltage
Field accommodating several thousand spectators.	15- 30	80	10	8	120
	30- 75	80	8	10	120
	75-120	84	6	14	126
The better than average installation.....	15- 30	60	10	6	90
	30- 75	64	8	8	96
	75-120	60	6	10	90
Average high-school and small college field.....	15- 30	40	10	4	60
	30- 75	40	8	5	60
	75-120	42	6	7	63
Minimum installation for low-cost project.....	15- 30	32	8	4	48

units are generally used. Table 36 summarizes the recommendations for several classifications of fields.

The recommended mounting height is dependent upon the distance of the floodlights from the side lines of the playing field. The relationship may be determined from Fig. 123.

d. Others.—Recommendations for the number of locations, mounting height, and the number and size of floodlights for

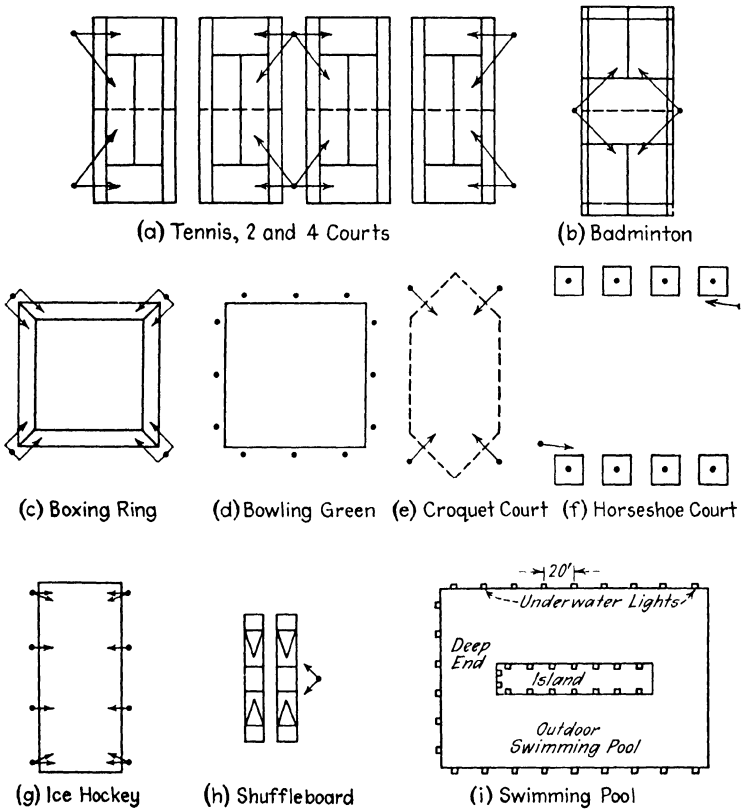

FIG. 124.—Miscellaneous floodlighting layouts.

several minor sports are included in Table 37. These particular recommendations are based upon average municipal requirements, and reasonably good results will be obtained if these are followed as a general guide. The locations of units are illustrated in Fig. 124.

TABLE 37.—RECOMMENDATIONS FOR GENERAL SPORTS LIGHTING

Sport	Number of locations	Mounting height	Number and size of floodlights	Total kilowatts at rated voltage
Tennis.....	4 (2 courts)	30-35	8-1500 watts	12
Tennis.....	6 (4 courts)	30-35	16-1500 watts	24
Badminton.....	2	30	4-1000 watts	4
Boxing.....	4	18	8-1000 watts	8
Bowling.....	12	25	12-1500 watts	18
Croquet.....	4	20	4-1000 watts	4
Horseshoe.....	2 (4 courts)	20	2- 750 watts	1.5
Ice hockey.....	8	35	12-1500 watts	18
Shuffleboard.....	1	20	2- 200 watts	0.4
Swimming pool (under-water lighting).	From 2 to 3 watts per square foot of pool, bottom surface		1000 or 1500 watts	

Problems

1.14. The front of a building 65 ft. wide by 125 ft. high is to be rather uniformly illuminated above an elevation of 12 ft. The building is in a city of 75,000 population, and its front surface is of Bedford limestone. Rental space is available on the roof of a building across the street. The roof of this building is 40 ft. above street level, and the floodlights must be located in one position 110 ft. from the closest point on the surface to be illuminated and opposite one edge of that surface. Prepare a layout of the projectors to be used specifying the aiming position for each projector. What average illumination will be maintained with the equipment chosen?

2.14. A parking area 80 by 150 ft. is to be floodlighted. On one side of the area is a two-story building extending back 120 ft. from the street. The back end of the parking area borders on an alley, and the other two sides border on streets. The roof of the adjoining building is 30 ft. above the parking area and can be used for locating floodlighting units. Prepare a layout of a floodlighting system for this area showing all equipment as regards size, beam characteristics, and aiming positions.

3.14. A high-school football field is to be illuminated by floodlighting units placed 15 ft. from the side lines. The football field is 300 by 160 ft. Show a layout of the system of floodlighting units giving size of units, beam spread, mounting heights, and aiming positions. For the floodlighting units chosen, what is the average illumination upon the playing field if the units are operated at rated voltage?

REFERENCES

- "Floodlighting," General Electric Company, 1931.
- E. B. Hallman, Floodlighting Design Procedure as Applied to Modern Setback Construction, *Trans. Illum. Eng. Soc. (N.Y.)*, **29**, 1934, pp. 287-295.
- "Westinghouse Illumination Design Handbook," Westinghouse Electric Company, 1936.
- "Illumination Design Data," General Electric Company, 1936.
- "How to Floodlight Football Fields," *Gen. Elec. Co. Bull.* GEA-3218, 1939.
- R. J. Swackhamer and G. G. Bobst, Lighting for Night Sports, *Trans. Illum. Eng. Soc. (N.Y.)*, **35**, 1940, p. 447-457.

CHAPTER 15

DESIGN OF STREET-LIGHTING SYSTEMS

<i>Symbol</i>	<i>Term</i>	<i>Definition</i>
	Discernment	The recognition of the presence of an object and its identifying contours.
	Iso-foot-candle diagram	A diagram illustrating points of equal illumination.
<i>B'</i>	Equivalent veiling brightness	A glare condition can be expressed as a veiling brightness that would reduce visibility equivalently.

87. General.—The major purposes of urban street lighting as formulated by the Committee on Street and Highway Lighting of the Illuminating Engineering Society are

a. To promote safety and convenience in the streets at night through adequate visibility.

b. To enhance the community value of the street.

c. To increase the attractiveness of the street

The first of these purposes applies equally well to the lighting of interurban highways, since safety is the major factor to be considered in such lighting.

The principal technical problems of lighting either the urban street or the interurban highway involve means of providing conditions of visibility adequate for accurate, certain, and comfortable seeing. Consequently the problems of both are here considered jointly. Wherein radically different methods are utilized to obtain adequate visibility in street- and in highway-lighting practice, the distinction will be clearly drawn.

Many of the definitions and tables of this chapter are taken directly from "Recommended Street Lighting Practice," *Transactions of the Illuminating Engineering Society*, January, 1941.

88. Visibility.—Under the relatively simple traffic conditions of a generation ago the standards of lighting for streets and highways were rather adequately fulfilled by equally simple expedients such as lanterns and arc lamps. Today greatly increased traffic volume and speed have necessitated an enormous rise in our standards. As in other seeing tasks, the

visibility of the critical objects of the street or highway depends upon their size, brightness, brightness contrast with their background, brightness pattern of the surrounding visual field, and the time available for seeing. This last factor has been tremendously reduced in our present modes of vehicular travel. Consequently other factors must compensate for the short time intervals involved if visibility is to be maintained at an adequate level. Except for the size of the critical objects, the other factors involved are at least partially under the control of the illumination engineer.

89. Methods of Discernment.—A clear understanding of how one discerns an object on a street or a highway at night is essential to an illumination engineer if he is to be capable of designing an adequate and efficient highway- or street-lighting system.

a. Silhouette.—An object is discerned by silhouette when the general level of brightness of all or a substantial part of it is lower than the brightness of its background. This method of discernment predominates in the observation of distant objects on lighted streets and highways where the object itself may possess relatively low average brightness in the direction of the observer whereas the street or highway may possess a relatively high background brightness.

b. Reversed Silhouette.—An object is discerned by reversed silhouette when the general level of brightness of all or a substantial part of it is higher than the brightness of its background. Such brightness of an object depends upon direct illumination on its side toward the observer. The outline of the object is discerned against a relatively dark background with little or no knowledge as to the surface details of the object.

c. Surface Detail.—When an object is seen by virtue of the variations in brightness or in its spectral emission over its surface, without regard to its general contrast with its background, it is discerned by surface detail. Such brightness depends upon a rather high direct illumination on the side toward the observer.

Where high illumination is employed, as on some business streets and heavy-traffic thoroughfares, discernment of near-by objects is accomplished chiefly by surface detail. In the first case it may be desirable to ascertain the individual nature of objects so as to recognize acquaintances, read street names, and

accomplish similar operations. In the condition of heavy-traffic thoroughfares the pavement may be largely obscured by a shifting pattern of vehicles, and hence discernment by either type of silhouette may be seriously impaired. Since discernment by surface detail involves recognition of the smaller details of objects, it is a relatively high order of seeing, which contributes to assurance and comfort as well as to safety.

d. Glint.—When luminous flux falls on a specular surface, the reflection forms an image at the observer, not of the object, but of the luminous source from which the flux originated. Usually the reflecting surface is not a plane and hence the image may be distorted. A. J. Sweet in "Fundamentals of Rural Highway Lighting" states the process of such discernment very lucidly in saying: "The observer, therefore, does not truly 'see' the object, but discerns its presence by an unconscious process of reasoning, deducing from the experience of life that a light source would not be in the location from which the light comes, and further deducing, by the apparent position and by the nature of the blurring, the character of the object which is producing the reflection." This method of discernment is called discernment by glint.

e. Shadows.—An object, which may be invisible because of equality of brightness between itself and its background, may cast a shadow. This shadow may present an interruption of the general brightness pattern to an observer, thus disclosing the presence of the object. The object is therefore discerned by a mental interpretation of the disturbed brightness pattern.

Although illuminating engineering opinion varies considerably as to the relative importance of discernment by the various methods, it is generally agreed that except for business streets and heavy-traffic thoroughfares lighting systems designed primarily for the direct-silhouette method give maximum safety conditions for a very moderate expenditure. Reid and Chanon have suggested that, until more precise criteria are established, we consider discernment by silhouette and by surface detail for design and evaluation purposes as having the following relative importance:

a. Open-highway high-speed traffic with large clearance distances between adjacent vehicles, discernment by silhouette 90 per cent and by surface detail 10 per cent.

b. Heavy-traffic thoroughfares, discernment by silhouette 70 per cent and by surface detail 30 per cent.

c. Well-lighted business districts or extremely heavy-traffic thoroughfares where pavement is largely obscured by dense traffic, discernment by silhouette 50 per cent and by surface detail 50 per cent.

90. The General Design Problem.—A careful study of the various physical characteristics of the street or highway to be lighted is required if the lighting design is to provide adequate visibility conditions. The following points of view should be considered:

a. *Type of street or highway*—a classification according to the use of the street or highway and of abutting property.

b. *Traffic*—the character, speed, and volume of vehicular traffic and the volume of pedestrian traffic.

c. *Dimensions and configurations*—the width of street and sidewalk areas (if such exist). Curb contours or absence of curbs.

d. *Street or highway surface*—the type and spectral- and geometric reflection characteristics of paved or unpaved surfaces.

e. *Buildings*—the predominating type of building construction on adjacent areas and the character of use. (This applies principally to street lighting.)

f. *Transportation*—public-transportation facilities by street railway or buses. (This likewise applies principally to street lighting.)

g. *Parking*—the location of parking lanes or highway “shoulders” and the amount and method of parking.

h. *Trees*—the presence or absence, kind, location, and height of trees; spread of branches over street, highway, and sidewalks; and the height of lower branches.

The classification of streets and highways may be made according to the character of the abutting property. Generally the method by which the lighting is accomplished is influenced by this classification. The nature of the source of luminous flux, the type of luminaire, and the style of post are items that would be so governed. Headings under which the classification could be accomplished are:

- a. Primary business streets
- b. Secondary business streets

- c. Industrial streets
- d. Residential streets
- e. Boulevards
- f. Viaducts and bridges
- g. Urban express roadways
- h. Alleys
- i. Two-lane interurban highways
- j. Three-lane interurban highways
- k. Four-lane interurban highways
- l. Divided traffic lane highways

The Street Lighting Committee of the Institute of Traffic Engineers has recommended that streets be classified in accordance with their traffic as is shown in Table 38.

TABLE 38.—CLASSIFICATION OF STREET TRAFFIC

Classification	Volume of Vehicular Traffic (Maximum Night Hour, Both Directions)
Very light traffic.....	Under 150
Light traffic.....	150- 500
Medium traffic.....	500-1200
Heavy traffic.....	1200-2400
Very heavy traffic.....	2400-4000
Heaviest traffic.....	Over 4000

Except for installations of lighting equipment such that discernment by surface detail is accomplished, a specification of the illumination required upon a street or highway gives only a partial specification of the necessary conditions. The ultimate specification should be in terms of the visibility afforded by the system. At the present time such specifications are only in proposal form, although much progress is being made in this aspect of lighting. The values given in Table 39, then, hold only when the pavement-reflection characteristics are favorable, as in the case of light concrete or light-finished asphalt. Somewhat higher values should be employed where street-surface reflections are less favorable. Where there is considerable pedestrian traffic, provision should be made for adequate lighting of sidewalks.

Various combinations of lamp sizes, types of luminaires, longitudinal spacings, and mounting heights may produce the illumination levels of Table 39. Certain ranges of combinations

TABLE 39.—LUMENS PER SQUARE FOOT (FOOT-CANDLES) RECOMMENDED FOR VARIOUS TYPES OF ROADWAY CARRYING TRAFFIC OF VARIOUS DEGREES OF DENSITY

Classification	Very light traffic		Light traffic		Medium traffic		Heavy traffic		Very heavy traffic	
	Average	Minimum	Average	Minimum	Average	Minimum	Average	Minimum	Average	Minimum
Principal business streets			0.4	0.1	0.8	0.2	1.2	0.3	1.5	0.4
Secondary business streets			0.3	0.07	0.6	0.15	1.0	0.25	1.3	0.3
Through high-speed arteries (other than business streets)			0.3	0.07	0.6	0.15	1.0	0.25	1.3	0.3
Express free ways and viaducts					0.4	0.1	0.8	0.2	1.2	0.3
Residence streets	0.1	0.02	0.2	0.05	0.4	0.1				
Industrial warehouse streets	0.1	0.02	0.2	0.05	0.4	0.1				

TABLE 40.—GENERAL CONSIDERATIONS IN SIZE AND LOCATION OF UNITS

Classification	Lamp lumens	Mounting height, ft.	Spacing measured along middle line of street, ft.
Very light traffic	1000	15	90-110, staggered
	2500	20-22	130-170, staggered
	4000	25-30	200-250, center
Light traffic	2500	16-18	100-120, staggered
	4000	20-25	130-170, staggered
	6000	22-25	130-170, centered
Medium traffic	6000	20-25	100-120, staggered
	10,000	22-27	130-170, staggered
	15,000	25-30	130-170, staggered
Heavy traffic	10,000	24-28	100-150, opposite
	10,000	24-28	75-90, staggered
	15,000	24-28	150-180, opposite
Very heavy traffic	15,000	25-30	100-150, opposite
Heaviest traffic	15,000	25-30	100, opposite

shown in Table 40 have been found to produce effective results for most well-designed commercial luminaires of today. Because of greater street widths, larger lamps or closer spacings usually are required on business streets to produce desired results. Among the values in the table the larger lamps or the closer spacings are appropriate on business streets.

91. Surface Brightness of Streets and Highways.—Except for those streets upon which discernment of objects is principally by surface detail, the tabulated values of illumination in Tables 39 and 40 are only general guides. More important than the maximum, average, or minimum illumination are the brightness and brightness variation of the pavement as viewed by the motorist and pedestrian.

Many studies of pavement brightness, employing widely different techniques, have been made. These studies have established the fact that practically no hard-surface roadway is capable of reflecting luminous flux diffusely where the angles of incidence viewing may be relatively large. The general discussion in Art. 44 considered the case of such large angles of incidence.

A pedestrian or a motorist whose eyes are 56 in. above the pavement views a level pavement at 200-ft. range at a viewing angle of 1.34 deg. At closer range the angle is larger, *e.g.*, being 1.8 deg. at 150 ft. Conversely at greater range the angle becomes smaller, approaching zero at the horizon. The brightness of the roadway at approximately 200 ft. ahead of the vehicle is of primary importance to the operator of such a motor vehicle traveling at speeds greater than those encountered in business districts.

Reid and Chanon have reported the results of a laboratory study upon the reflecting properties of several sections of roadway surface cut from roadways that had been in use for eight or nine years. With the incident light adjusted to predetermined values, brightness measurements were made with the Luckiesh-Taylor brightness meter. This instrument is a visual comparison device similar to the Macbeth illuminometer previously described but with a very restricted field of view. The incident light was directed on the pavement samples at angles from 0 deg., or nadir, to 89 deg., corresponding to all lamp positions of significance in street and highway lighting. For representa-

tive mounting heights these angles embraced test points over surfaces up to 100 ft. in width and within 1500 ft. of the source.

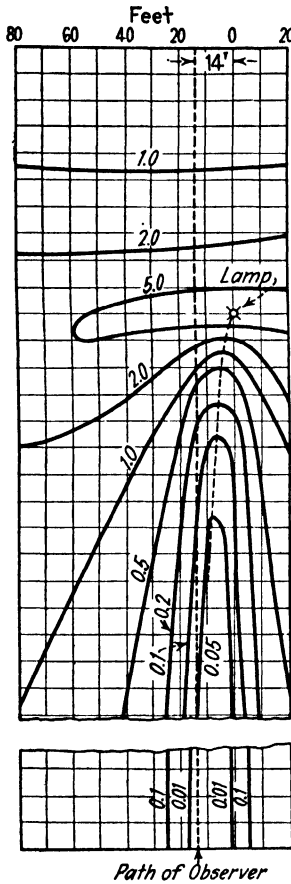

FIG. 125.—Iso-foot-candle diagram for traffic-worn concrete to give uniform pavement brightness of 0.32 candle per square foot (lamp mounted 25 ft. high).

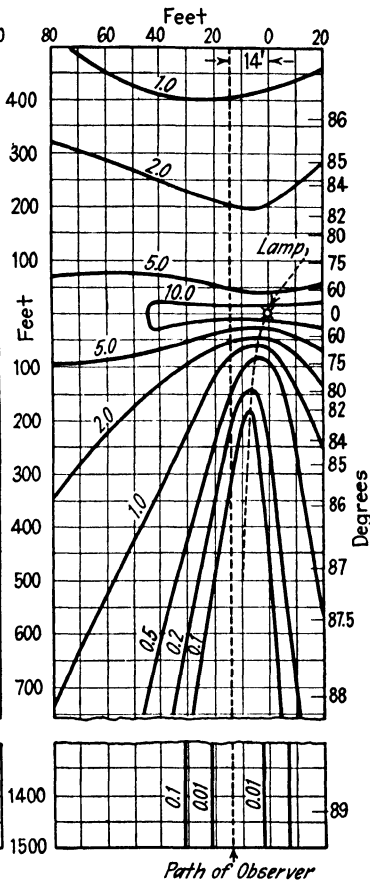

FIG. 126.—Iso-foot-candle diagram for traffic-worn asphalt to give uniform pavement brightness of 0.32 candle per square foot (lamp mounted 25 ft. high).

Angles in view were investigated from 1.8 to 0.9 deg. The brightness values for the angles in this range differed so slightly that only the angle corresponding to 200-ft. range at 56-in. elevation was used in the main tests.

Two sets of data are reported (both upon dry samples): one upon concrete, the other upon asphalt. The reflection factor

of the concrete was 22 per cent, representing principally the diffuse characteristic of the surface. That for the asphalt pavement under similar conditions of measurement was 8 per cent.

The manner in which the data are presented by Reid and Chanon can best be described with reference to Fig. 125. The area represents a section of a traffic-worn concrete street. The lamp is located at the origin of the coordinate system shown and is mounted 25 ft. above the pavement. The path of the observer is always along the dashed line in the figure, which is 14 ft. to the left of the lamp position. Note that for conciseness in presentation the scale of dimensions perpendicular to the path is expanded with respect to that along the path. Imagine an observer at the 400-ft. point looking toward the pavement in the general direction of the lamp (upward on the figure). At the point on the path directly 200 ft. before him, note that the iso-foot-candle diagram gives an approximate value of 0.2 ft.-candle. This indicates that if the illumination at this position on this particular pavement is 0.2 ft.-candle for the lamp position as shown, the brightness of the pavement will be 0.32 candle per square foot. Any point on the pavement 200 ft. distant from the observer still at the 400-ft. mark will also exhibit the same brightness if the illumination at the respective point is that obtained from the iso-foot-candle diagram. (The observer must always be looking in the general direction of the path but not necessarily along it. As he comes closer than 200 ft. to the lamp position, he may be looking at points past the lamp.)

If the illumination is x foot-candles from some actual light source at some point on the surface as viewed from a location on the path, then the brightness of such a point will be $0.32(x/\text{iso-foot-candle value from the figure})$ in candles per square foot, since the cause-and-effect phenomena are linear.

The mounting height of the lamp is 25 ft. for the figure as shown. However, this chart can be used in obtaining brightness results for any mounting height within reason. The relationship between illumination and the pavement brightness is dependent only upon the angle of incidence for a fixed observer and a fixed pavement point. Consequently, if the height of the lamp is h feet rather than 25 ft., the scales of the street area must be changed in the same proportion, *viz.*, $h/25$, thus maintaining the iso-foot-candle curves at the same angles of incidence as before.

Although technically only points 200 ft. distant from the observer can be investigated as to brightness, actually any points more than perhaps 75 or 100 ft. away from the observer will yield brightnesses possessing very little error.

By means of an iso-foot-candle diagram for a particular luminaire, the brightness in candles per square foot produced at each point on the roadway by the luminaire may be obtained by dividing the delivered foot-candles by the foot-candles from the iso-foot-candle diagram and multiplying the ratio by 0.32. A similar determination for other near-by luminaires permits a summation of the brightness produced at each point. The curves of Art. 29 may be employed to advantage if the photometric data on the luminaire is in terms of its intensity distribution.

A similar iso-foot-candle diagram is shown in Fig. 126 for a traffic-worn asphalt pavement.

The spacing, mounting height, and size of lamp may be adjusted to give various degrees of uniformity of brightness as well as to obtain the actual values of brightness for a particular luminaire. In general the more uniform the brightness of the roadway surface the less opportunity there will be for failure to discern an object because it chances to lie in a region of low brightness.

The curves of Fig. 125 and 126 are not general relationships that can be applied under all conditions with no errors, and their limitations should be realized in applying them to street- and highway-lighting designs. As the data are presented, the observer must always be on a line 14 ft. offset from the position of the lamp. If other paths of observation are required, technically the curves would need to be replotted, taking account of the 200-ft. distance as a variably rotated radius. Actually, except for points close to the lamp, a very good approximation can be obtained if, with the new street plan stationary, the family of iso-foot-candle lines is rotated with the lamp as a pivot until the axis through the valley of the lines (which is shown as the dotted curve) is tangent to the desired viewing position at such a distance from the lamp source as seems most desirable. Such a method may be applied in laying out brightness patterns for curving as well as straight roads.

The results as shown in the data apply to dry pavement conditions. For two points, one in line with the lamp and the

other outside the possible high brightness area, the ratio of brightness for a given illumination may be, for example, 5 to 1 (or the illumination for a constant brightness may be 1 to 5) under dry conditions. Wetting the surface changes the specular condition of the pavement tremendously, and the same points may exhibit a brightness ratio as high as 4000 or 5000 to 1 for equal illuminations. Consequently the data give not even an approximation for moisture conditions on the pavement.

92. Evaluation of Discernment by Silhouette.—The visibility of an object discerned by silhouette increases as the pavement brightness increases. Tests by Reid and Chanon upon 25 observ-

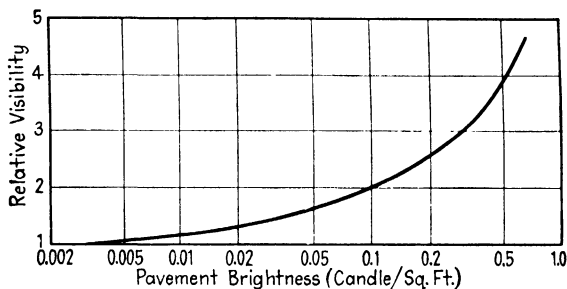

FIG. 127. —Obstacle brightness by silhouette.

ers with so-called normal eyesight yielded the results shown in Fig. 127. The values of relative visibility are average readings on the Luckiesh-Moss visibility meter for the observers. The object represented a 1-ft. disk of virtually zero brightness at a 200-ft. distance. The study was a laboratory study with no sources possessing high brightness in the field of view. The values are carried to a relative visibility of 1 because this may be considered the minimum degree of seeing having any direct value as applied to safety on streets or highways.

This value corresponds to a minimum pavement brightness of approximately 0.003 candle per square foot. If all conditions were favorable to the ultimate degree, this brightness could be obtained with an average illumination of an extremely small fraction of any of those of Table 39 (of the order of magnitude of several hundredths of 1 ft.-candle). Exceedingly accurate control of the luminous flux would be necessary both from the viewpoint of the illumination distribution upon the roadway

and, more important, for the elimination of direct glare of the source from the observers viewpoint.

Upon level highways these two goals are in general mutually contradictory when the economics of longitudinal spacings are considered. However, upon upgrade hills the glare from the source can be reduced tremendously *when the observer views that hill from near the crest of another hill*. Such conditions can often be observed when the roadway of an upgrade hill is illuminated only by the headlamps of an oncoming vehicle descending the hill while the observer is still descending a previous grade and before he approaches the minimum elevation. Under such conditions the glare from the lamps on the oncoming vehicle is exceedingly low and hence is not veiling the roadway brightness from the observer's view.

The average illumination upon the pavement for several hundred feet in front of the oncoming vehicle is of the order of magnitude of several hundredths of 1 ft.-candle. The roadway is hence of the range of brightness of minimum seeing conditions for discernment by silhouette. An observer who has noted this effect will generally agree that such pavement brightness will permit discernment by silhouette of objects subtending reasonably large visual angles but that for smaller objects the pavement brightness is not conducive to rapid discernment.

93. Evaluation of the Loss in Visibility because of Glare.—Street- and highway-lighting systems produce a degree of blinding and hence a reduction in visibility because of the glare inherent in the system. This blinding effect has been studied by several observers. It is generally concluded that the angle of the glare source with respect to the line of vision is an important specification of the blinding effect. The blinding effect decreases as this angle is increased. Researches by Holladay have indicated that the distance of a given source from the observer is likewise a contributing factor. This seems logical, since the portion of the retina occupied by the image of a particular blinding source is a variable with distance—the area increasing as the object becomes closer even though the retinal brightness may be constant. Holladay has shown that the blinding effect may be expressed as an equivalent veiling brightness empirically related to the conditions of a single glare source through

$$B' = \frac{7.3E_i}{\delta^{1.8}} \quad (118)$$

where B' = equivalent veiling brightness, in candles per square foot.

E_i = illumination from the glare source at the observer's eyes and upon a plane normal to the line from the eyes to the glare source, in foot-candles.

δ = angle between the source and the line of vision, in degrees.

For two or more glare sources the resultant veiling brightness was found to be approximately the sum of the equivalent veiling brightnesses due to each acting alone.

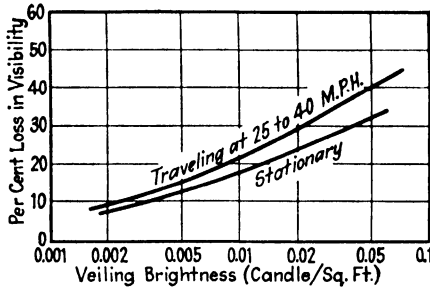

FIG. 128.—Effect of glare on discernment.

A motorist driving along a lighted roadway is subjected to constantly fluctuating veiling brightnesses dependent upon the particular lighting system. In general at speeds of 25 to 40 miles per hour the loss of visibility has been found to be approximately 20 per cent greater than for a constant veiling brightness equal to the average for successive roadway positions. Tests upon 11 observers by Reid and Chanon for various amounts of veiling brightness produced the results of Fig. 128. Pavement brightnesses ranging from 0.02 to 0.6 candle per square foot were employed in the study. The curves are average ones that apply with reasonable accuracy to all pavement brightnesses in this range.

Minimum acceptable mounting heights are shown in Table 41 for reasonable glare conditions.

94. Relationship between the Illuminating Engineering Society Code Classifications of Traffic and Relative Visibility.—Although

TABLE 41.—MINIMUM ACCEPTABLE MOUNTING HEIGHTS FOR LUMINAIRES, IN FEET^a

Lamp size, lumens	When using luminaires of maximum concentration (beam candle-power approximate 6/10 of lumen rating) (see note <i>b</i>)	When using semi-concentrating luminaires (beam candle-power equals 3/10 of lumen rating) (see note <i>c</i>)	When using diffusing globes only (maximum candle-power approximate 1/10 of lumen rating)
1,000 (<i>d</i>)	15	15	15
2,500 (<i>e</i>)	18	18	18
4,000	20	18	18
6,000	22	18	18
10,000	25	21	18
15,000	28	24	18
25,000	33	27	20

NOTES: *a*. Observe that the above are recommended minimum mounting heights. Higher mounting heights than these generally are preferable.

b. For example, a reflector-refractor type of luminaire providing this high degree of concentration.

c. There are other luminaires that have been designed to give some degree of light redirection with reflecting or refracting equipment (sometimes using outer globes) which do not attain the high degree of concentration defined in column 2. From a glare standpoint these can be mounted somewhat lower as indicated.

d. The 1000-lumen lamps are to be used for between-intersection lighting only, on very light-traffic streets and in alleys. No conditions of street lighting prevailing in the United States justify the use of smaller than 1000-lumen lamps. The 2500-lumen lamp is the smallest size that may be used with good economy.

e. On forested streets a 15-ft. mounting height for 2500-lumen lamps may be permissible provided close spacing is used with post-top units.

no classifications of relative visibility appear in the "1940 Recommended Practices of Street Lighting" of the Illuminating Engineering Society as standards, Reid and Chanon have proposed values based upon their researches. These values of relative visibility or revisions of them hold promise of later being accepted as standards. The proposal is incorporated in a graphical construction chart embodying the essential ideas discussed in this chapter. A modification of the chart appears in Fig. 129 and is in reality a plot of Fig. 127 and the upper curve of Fig. 128.

An example will illustrate the use of the chart. The following data are known from calculations, as previously discussed, or from tests: (*a*) the average pavement brightness is 0.09 candle per square foot; (*b*) the obstacle brightness is 0.02 candle per square foot; (*c*) the street is a heavy traffic thoroughfare; and

(d) the average equivalent veiling brightness from equation (118) is 0.03 candle per square foot. The relative visibility is desired.

The construction details follow: Mark the points *P* and *O* on the respective pavement-brightness and obstacle-brightness scales. Draw a construction line joining these points. Deter-

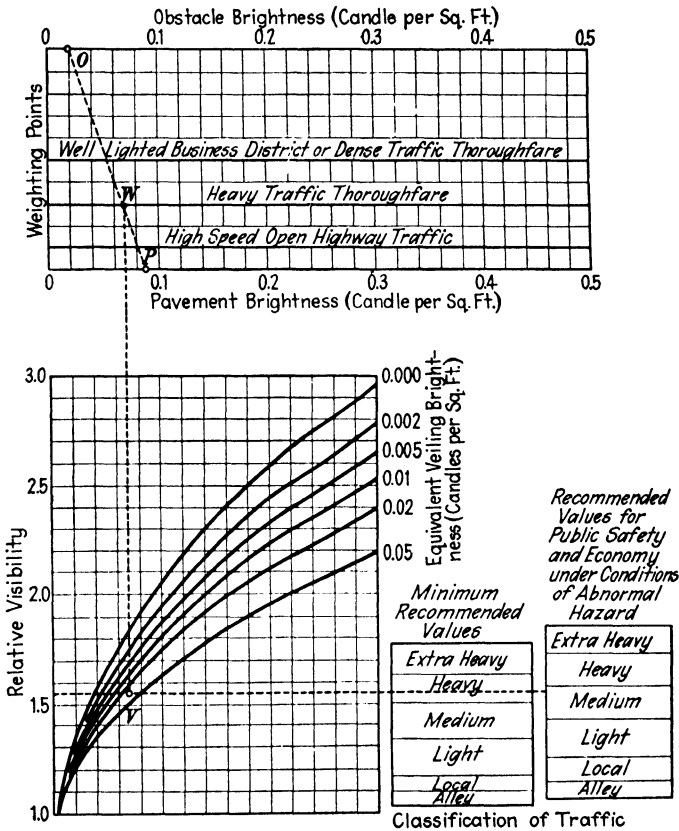

FIG. 129.—Street-lighting evaluation chart for observer in motion at 25 to 40 miles per hour.

mine the intersection of this line with the heavy-traffic thoroughfare, yielding point *W*. This construction weighs the discernment by silhouette and by surface detail in the ratio of 70 to 30, respectively. Project vertically downward to an interpolation on the family of equivalent-veiling-brightness curves to the value of 0.03 candle per square foot. The ordinate

at this point (V) is the relative visibility for the conditions stated. The value is found to be 1.55. This value projected to the right enters the block labeled heavy-traffic conditions or medium-traffic conditions depending upon whether minimum recommendations or hazard recommendations are considered. The result is the average evaluation of the system. Often of more interest is the lowest value of visibility afforded by a system. The lowest values of pavement and obstacle brightness and the highest value of veiling brightness encountered at any position on the street or highway should be used for such an evaluation.

95. Critical Discussion.—At best the method just described may be of relatively low precision. The data represented in Figs. 127 and 128 were obtained for discernment by silhouette alone. The first weighing process (itself on a rather arbitrary basis) brings in discernment by surface detail. From that point on, the weighted value is treated to relationships obtained actually for silhouette discernment.

Also the numerical evaluation of veiling brightness is subject to the limitations of equation (118). If several sources are contributing to the blinding effect, the summation of the component veiling brightnesses yields only an approximation of the integrated effect.

The interrelationship between traffic classifications and relative visibilities can be arrived at only by practice. Such practice cannot come about overnight.

It is only when we can measure concepts in a subject that that subject can advance from the classification of an "art" to a "science." In the past much in street lighting has been "art." There is need that it be a science, and only by establishing the size of things can that end be attained.

Consequently we are much in advance of the days when planning a street-lighting system consisted of mounting a map on a board and sticking in colored-headed pins to represent lighting units on different classifications of streets. If the heads of the pins came too close together, one of two things was wrong—either the scale of the map was too large, or the luminaires were being placed too close together. Which was wrong was a matter of conjecture. The engineering of street and highway lighting has passed through the embryonic stage. It is now coming into its own right.

REFERENCES

- L. L. Holladay, The Fundamentals of Glare and Visibility, *J. Optical Soc. Am.*, **12**, 1926, p. 271.
- K. M. Reid and H. J. Chanon, Studies in Fundamentals of Highway Lighting, *Trans. Illum. Eng. Soc. (N.Y.)* **31**, 1936, p. 481.
- A. J. Sweet, Fundamentals of Rural Highway Lighting, *Trans. Illum. Eng. Soc. (N.Y.)*, **31**, 1936, p. 481.
- K. M. Reid and H. J. Chanon, Evaluation of Street Lighting, *Trans. Illum. Eng. Soc. (N.Y.)*, **34**, 1939, p. 1209.
- K. M. Reid and H. J. Chanon, A Street Lighting Evaluator, *Trans. Illum. Eng. Soc. (N.Y.)*, **35**, 1940, p. 72.
- Recommended Practice of Street Lighting, 1940, *Trans. Illum. Eng. Soc. (N.Y.)*, **36**, 1941, p. 17.

INDEX

A

- Absorption, 97
- Angstrom unit, 3
- Angular correction, light-sensitive cells, 55
- Apparent intensity, 29-30
 - determination of, 55
- Architectural elements, luminous, 202
 - banded effects, 202
 - brightness of, 215
 - graduated or shaded, 202
 - spotty, 202
 - uniform, 202
 - table, 208-214
 - efficiency, 202, 215
 - table, 208-214
 - exterior, 203
 - luminosity values, 204
 - interior, 204
 - maximum brightness limits, 205

B

- Badminton courts, floodlighting, 248-249
- Barrier layer cell, 52
- Base designations, lamp, 114
- Baseball fields, floodlighting, 245
- Beam lumens, 229, 234, 236
- Beam spread, 229, 235
- Black-body radiator, 10-11, 21, 36
- Bowling greens, floodlighting, 248-249
- Boxing rings, floodlighting, 248-249
- Brightness, 15, 19, 21, 22, 24, 31-39, 41-42
 - architectural elements of, 215

- Brightness, relationship between, and luminosity for perfectly diffusing source, 74-75
 - surface, of streets and highways, 257-261
 - veiling, equivalent, 251, 263
- Brightness contrast, 159
- Brightness-distribution curve, 69
- Brilliance, 14, 15, 22
- Bulb shapes, lamp, 114

C

- Caloric system, 20
- Candle, unit, 21, 27
- Candle power, 62
 - distribution curve, 61-63, 173, 220
 - determination of, 55
 - mean hemispherical, 61, 68
 - mean spherical, 61, 68
- Circular-disk source, illumination from, 81-84
- Coefficient of distribution, 173, 175, 182, 185, 187
 - chart, direct, 181
 - horizontal, 181
 - indirect, 180
- Coefficient of utilization, 173, 186
 - table, fluorescent luminaires, 196-199
 - incandescent luminaires, 188-195
- Cold-cathode lamp, 112
- Color, 14, 15, 21
- Commission of Illumination, International, 14, 15
- Component flux, 173
 - direct, 184
 - horizontal, 184
 - indirect, 184

- Continuous-spectrum source, 7-9, 26, 40, 102
- Contrast, brightness, 159
- Correction, angular, light-sensitive cells, 55
- Cosine law, illumination, 27
- Croquet courts, floodlighting, 248-249
- D
- Density, radiant-energy, 2
radiant-power, 1, 2
- Diffuse reflection, 98
- Diffuse surfaces, 96
- Diffusion, perfect, 61
relationship between luminosity and brightness, 74-75
- Direct component flux, 173, 184
- Discernment, 251
methods of, 252
by silhouette, evaluation of, 261
- Disk, circular, illumination from, 81-84
- Distribution, coefficient of, 173, 175, 182, 185, 187
chart of, direct, 181
horizontal, 181
indirect, 180
- Distribution curve, brightness, 69
illumination, 72
intensity (candle power), 61-63, 173, 220
determination, 55
- Dynamical system, 19
- F
- Efficiency, luminaire, 61, 173, 185
- Electromagnetic system, 20
- Electrostatic system, 19
- Elements, luminous architectural, 202
banded effects, 202
brightness of, 215
graduated or shaded, 202
spotty, 202
uniform, 202
table, 208-214
- Elements, luminous architectural, efficiency, 202, 215
table, 208-214
exterior, 203
luminosity values, 204
interior, 204
maximum brightness limits 205
- Emission, 1
spectral, 1, 10, 16
- Enclosed floodlights, 230-231
- Energy, radiant, 1, 41
spectral, 41
- Entities, illumination system, summary, 43-45
- Evaporation, filament, incandescent lamp, 138
- Eye, human, 14, 25
- F
- Filament evaporation, incandescent lamp, 138
- Filter data, Corning, 108
Wratten, 107
- Floodlight lamps, 229
- Floodlighting, badminton courts, 248-249
baseball fields, 245
bowling greens, 248-249
boxing rings, 248-249
croquet courts, 248-249
equipment for, location, 230, 235
types, 230
football fields, 247-248
hockey rinks, ice, 248-249
horseshoe courts, 248-249
- Floodlights, enclosed, 230-231
open, 230-231
- Fluorescence, 11, 96
- Fluorescent lamps, 11-13, 112, 144-157
ballast equipment for, 150, 151
circuits for, 147-249
operating characteristics, 149-157
power-factor correction, 149, 152
ratings, 146, 153, 154
spectral irradiation from, 12
starters for, 147

- Flux, lamp, 173
 luminous, 24, 39, 41
 determination, 57, 66-68
 total, 173
 Football fields, floodlighting, 247-248
 Foot-candle, 27, 37, 40
 Foot-lambert, 41
 Frequency, 1, 3
- G
- Gaseous-discharge lamps, 112, 139
 Geometric graphs, 61
 Gibson and Tyndall, work of, 15
 Glare, 96, 99, 263
 Glint, 253
 Graphs, geometric, 61
- H
- Harrison and Anderson, work of, 174
 Hemispherical source, illumination
 from the inside, 79
 Heterogeneous radiation, 2
 Hockey rinks, ice, floodlighting, 248-
 249
 Homogeneous radiation, 2
 Horizontal component flux, 173, 184
 Horseshoe courts, floodlighting, 248-
 249
 Hot-cathode lamp, 112
 Hue, 14, 15
 wave-length boundaries of aver-
 age individual, 102
 Human eye, 14, 25
- I
- Illumination, 24, 25
 components, 88
 cosine law, 27
 determination of, circular-disk
 source, 81-84
 hemispherical source (inside), 79
 irregular shape source, 94
 plane surface source of infinite
 extent, 77-78
 rectangular source, 84-90
 strip source, 90-94
- Illumination, distribution curve, 72
 inverse square law, 27-29
 measurements, visual methods, 47
 standards, commercial and public
 interiors, 163-166
 floodlighting, 231-233
 industrial interiors, 166-172
 recommended, 159, 161-172,
 231-233, 256
 stores, 162
 street lighting, 256
 Illuminometer, 47
 Macbeth, 48
 Image, 220
 Images, method of, 221-224
 Incandescence, 7, 96, 112
 Incandescent lamps, 21, 112-139
 base designations, 114
 bulb shapes, 114
 economics of voltage variation,
 135-138
 filament evaporation, 138
 history, 113
 life of, variation with voltage, 134
 operating characteristics, 134
 ratings, 115-133
 spectral irradiation from, 9
 Indirect component flux, 173, 184
 Intensity, 21, 27, 62
 apparent, 24, 29-30
 determination, 55
 distribution curve, 61-63, 173, 220
 element of source, 69
 International Commission of Illumi-
 nation, 14, 15
 Interreflections, 173, 214
 Inverse square law of illumination,
 27-29
 Irradiation, 1, 5, 9, 25
 spectral, 1, 26
 Iso-foot-candle diagram, 74, 251, 258
- L
- Lamp, cold-cathode, 112
 floodlight, 229, 234
 fluorescent, 11-13, 112, 144-157
 flux, 173

- Lamp, gaseous-discharge**, 112, 139
 hot-cathode, 112
 incandescent, 21, 112-139
 life, 112
 mercury vapor, high-pressure, 6,
 139-143
 low-pressure, 7
 sodium vapor, 143-144
- Law**, definition, 159
- Light**, 40
 center, 56
- Light-sensitive cells**, 51-55
 angular correction, 55
 barrier layer, 52
- Line-spectrum source**, 3-7, 25, 41
- Luckiesh-Moss visibility meter**, 160
- Lumen**, 40
- Lumen method**, 174, 220
- Lumens**, beam, 229, 234, 236
- "Lumens in the beam" method**,
 floodlighting calculation, 231,
 233
- Luminaire**, 173
- Luminaire efficiency**, 61, 173, 185
- Luminescence**, 4, 96, 112
- Luminosity**, 24, 41, 102, 109
 function, 17, 21, 22, 102, 110
 relationship between, and bright-
 ness, for perfectly diffusing
 source, 74-75
- Luminous architectural elements**,
 202
 banded effects, 202
 brightness of, 215
 graduated or shaded, 202
 spotty, 202
 uniform, 202
 table, 208-214
 efficiency, 202, 215
 table, 208-214
 exterior, 203
 luminosity values, 204
 interior, 204
 maximum brightness limits, 205
- Luminous flux**, 24, 39, 41
 determination, 57, 66-68
 incandescent lamp, variation with
 voltage, 134
- Luminous source**, 22
 primary, 96
 secondary, 97
- Lummer-Brodhun cube**, 48
- M**
- Macbeth illuminometer**, 48
- Magnetostatic system**, 19
- Maintenance factor**, 173, 200, 215
- Mat surface**, 99
- Mean hemispherical candle power**,
 61, 68
- Mean spherical candle power**, 61, 68
- Mercury vapor lamp, high-pressure**,
 6, 139-143
 low-pressure, 7
- Micron**, 3
- Model**, 220
 of lighting installation, 221
- Models**, testing by, 224-227
- O**
- Objective entities**, 14, 22, 25, 159
- Opaque bodies**, 97
- Open floodlights**, 230-231
- P**
- Phosphorescence**, 12, 96
- Photoelectric**, 47, 51
- Photometer**, 47
- Physical concepts**, 19
- Physiological concepts**, 19
- Plane surface source of infinite
 extent**, illumination from, 77-78
- Planimeter**, 7
- Platinum**, 21
 temperature of solidification, 36
- Power, incandescent lamp, variation
 with voltage**, 134
 radiant, 1
- Primary source**, 96
- Psychological concepts**, 19
- Q**
- Quantum theory**, 2

R

- Radiant energy, 1, 41
 - spectral, 41
- Radiant-energy density, 2
- Radiant power, 1
- Radiant-power density, 1, 2
- Radiation, 1
 - heterogeneous, 2
 - homogeneous, 2
 - thermocouple, 4
- Radiator, black-body, 10-11, 21, 36
- Recommended standards, illumination, 159, 161-172, 231-233, 256
 - commercial and public interiors, 163-166
 - floodlighting, 231-233
 - industrial interiors, 166-172
 - stores, 162
 - street lighting, 256
- Recreational floodlighting, 244-249
- Rectangular source, illumination from, 84-90
- Reflecting materials, 205-207
- Reflection, 97
 - diffuse, 98
 - specular, 98, 206
- Reflection factor, 96, 104, 206
 - spectral, 96, 101
- Relative visibility, 160, 261, 265-266
 - spectral, 14, 16, 25, 26, 41
- Reversed silhouette, 252
- Room index, 173, 178
 - charts for, 179
- Room ratio, 178

S

- Sample, 220
 - of lighting installation, 221
- Samples, testing by, 221-224
- Saturation, 14, 15
- Scale factor, 220, 226-227
- Secondary source, 96, 97
- Seeing, process of, 24
- Semi-mat surface, 99
- Sensitivity, 47
 - spectral, relative, light-sensitive cells, 52-55
- Setback construction, 229
 - floodlighting, 242-244
- Shadows, 253
- Shuffleboard, floodlighting, 248-249
- Silhouette, 252, 261
 - discernment by, evaluation of, 261
 - reversed, 252
- Size, visual, 159
- Sodium vapor lamp, 143-144
- Softball fields, floodlighting, 246-247
- Solidification temperature, platinum, 36
- Source, continuous-spectrum, 7-9, 26, 40, 102
 - line-spectrum, 3-7, 25, 41
 - luminous, 22
 - primary, 96
 - secondary, 97
- Spacing, of lamps in architectural elements, 214
 - of luminaires, interiors, 176
 - street lighting, 256
- Spectral emission, 1, 10, 16
- Spectral irradiation, 1, 26
 - fluorescent lamps, 12
 - incandescent lamps, 9
 - mercury vapor, high-pressure, 6
 - low-pressure, 7
 - sun, 9
- Spectral reflection factor, 96, 101
 - sensitivity, relative, light-sensitive cells, 52-55
 - transmission factor, 96
- Spectroradiometer, 5
- Spectroradiometric function, 6, 8, 21
- Specular surfaces, 96
- Specular reflection, 98, 206
- Spot sizes, floodlight, table, 238-241
- Spread, beam, 229, 235
- Standard, definition, 159
- Standards, illumination, 159, 161-172, 231-233, 256
 - commercial and public interiors, 163-166
 - floodlighting, 231-233

- Standards, illumination, industrial interiors, 166-172
 stores, 162
 street lighting, 256
- Street lighting, evaluation chart, 265
 units, location, 256
 mounting heights, 256, 264
- Street traffic, classification, 255
- Strip source, illumination from, 90-94
- Subjective entities, 14, 21, 25, 159
- Subtraction method of illumination, 83
- Sun, spectral irradiation from, 9
- Surface, detail, 252
 mat, 99
 semi-mat, 99
 specular, 98
- Swimming pool, floodlighting, 248-249
- Symmetry, intensity distribution, 62
- System, caloric, 20
 dynamical, 19
 electromagnetic, 20
 electrostatic, 19
 magnetostatic, 19
- T
- Tennis courts, floodlighting, 248-249
- Thermocouple, 4
- Three-curve calculation method, 174, 183, 220
- Total flux, 173
- Traffic, street, classification, 255
- Translucent bodies, 96, 207
- Transmission, 104
 diffuse, 105
 perfect, 105
- Transmission factor, 96, 109, 207
 spectral, 96, 106
- Transmitting materials, 207
- Transparent bodies, 96, 207
- U
- Ulbricht sphere, 57
- Unit candle, 21, 27
- Units, illumination system, summary, 43-45
- Utilization, coefficient of, 173, 186
 table, fluorescent luminaires, 196-199
 incandescent luminaires, 188-195
- V
- Vapor lamps, 112, 139
- Veiling brightness, equivalent, 251, 263
- Visibility, 251-252
 loss in, because of glare, 262
 meter, Luckiesh-Moss, 160
 relative, 160, 261, 265-266
 spectral, 14, 16, 25, 26, 41
- Visual methods, illumination measurement, 47
- Visual size, 159
- Voltage, incandescent lamp, economics, 135-138
- W
- Wave length, 3
- Wave-radiation, theory, 1, 2
- Working plane, 174
- Z
- Zonal constants, 68

