

BIRLA CENTRAL LIBRARY

PILANI (RAJASTHAN)

Call No

Accession No.

PROBLEMS IN RADIO
ENGINEERING

ALSO BY

E. T. A. RAPSON

EXPERIMENTAL ELECTRICAL ENGINEERING

A guide to the experimental work necessary for students taking the Ordinary and Higher National Certificates in Electrical Engineering, and also the B.Sc. and I.E.E. Examinations. 6s. net.

"A very meritorious production, reflecting great credit on the author and publishers. Will be very useful both to students and teachers."—ELECTRICAL REVIEW.

EXPERIMENTAL RADIO ENGINEERING

Assisted by
E. G. ACKERMANN

This book sets out a number of experiments and methods of measurements suitable for a three- or four-years' course in radio engineering. 159 pp. 8s. 6d. net.

"An admirable publication, supplying the type of instruction in practical work which is very difficult to obtain"—ELECTRICAL REVIEW.



PROBLEMS IN RADIO ENGINEERING

BY

E. T. A. RAPSON

M.Sc. (ENG.) LONDON, A.C.G.I., D.I.C.
M.BRIT.I.R.E., A.M.I.E.E., Assoc.I.R.E., F.P.S.

WHITWORTH EXHIBITIONER
HEAD OF THE DEPARTMENT OF RADIO ENGINEERING
SOUTHALL TECHNICAL COLLEGE

SIXTH EDITION



LONDON
SIR ISAAC PITMAN & SONS, LTD.

1946

First Edition 1935
Second Edition 1935
Third Edition 1938
Fourth Edition 1939
Revised Reprint 1940
Fifth Edition 1942
Reprinted 1943
Sixth Edition 1945
Reprinted with minor corrections 1946

SIR ISAAC PITMAN & SONS, LTD.
PITMAN HOUSE, PARKER STREET, KINGSWAY, LONDON, W.C.2
THE PITMAN PRESS, BATH
PITMAN HOUSE, LITTLE COLLINS STREET, MELBOURNE
UNITED BUILDING, RIVER VALLEY ROAD, SINGAPORE
27 BECKETTS BUILDINGS, PRESIDENT STREET, JOHANNESBURG
ASSOCIATED COMPANIES
PITMAN PUBLISHING CORPORATION
2 WEST 45TH STREET, NEW YORK
205 WEST MONROE STREET, CHICAGO
SIR ISAAC PITMAN & SONS (CANADA), LTD.
(INCORPORATING THE COMMERCIAL TEXT BOOK COMPANY)
PITMAN HOUSE, 351-353 CHURCH STREET, TORONTO



THE PAPER AND BINDING OF
THIS BOOK CONFORM TO THE
AUTHORIZED ECONOMY STANDARDS

MADE IN GREAT BRITAIN AT THE PITMAN PRESS, BATH
Dg. (T.35)

PREFACE

THESE problems were collected and classified to facilitate the class-work in Radio Engineering, which forms part of the course for the Higher National Certificate in Electrical Engineering developed at Southall Technical College.

They are drawn from past examination papers of the City and Guilds of London Institute in Radio Communication, the Institution of Electrical Engineers in Electrical Communications, and the University of London in Telegraphy and Telephony. Acknowledgments are made to these authorities for permission to reproduce the questions.

The descriptive examples have been included to guide those readers who are engaged in private study for the above examinations. References for further reading have been given to assist the private student.

E. T. A. R.

SOUTHALL TECHNICAL COLLEGE

PREFACE TO THE SIXTH EDITION

IN this edition two new chapters dealing with A.C. Bridges and Cathode-ray Tubes respectively have been added.

By permission of the Council, specimen examination papers of the British Institution of Radio Engineers have been included, and acknowledgment is hereby made to the Secretary, 9 Bedford Square, London, W.C.1.

A FIRST COURSE IN WIRELESS

By "DECIBEL."

Being a Reprint in Book Form of a series of articles which appeared in *World Radio* under the title "The Radio Circle; for Beginners Only."

In crown 8vo, cloth, 221 pp. 5s. net.

WIRELESS TERMS EXPLAINED

By "DECIBEL."

Based upon a series of articles which were published in *World Radio* under the title "A Wireless Alphabet."

In crown 8vo, cloth, 80 pp. 3s. net.

MODERN RADIO COMMUNICATION

By J. H. REYNER, B.Sc., A.C.G.I., A.M.I.E.E.

In two volumes. Each in crown 8vo, cloth gilt, illustrated.

Vol. I. 330 pp. 7s. 6d. net.

Vol. II. 255 pp. 7s. 6d. net.

THE RADIO AND TELECOMMUNICATIONS ENGINEER'S DESIGN MANUAL

By R. E. BLAKEY, D.Sc.

In demy 8vo, cloth, 142 pp., illustrated. 15s. net.

ELECTRIC CIRCUITS AND WAVE FILTERS

By A. T. STARR, M.A., Ph.D., A.M.I.E.E., A.M.I.R.E.

In demy 8vo, cloth gilt, 476 pp. 25s. net.

THERMIONIC VALVES IN MODERN RADIO RECEIVERS

A Handbook on Theory and Practice.

By ALFRED T. WITTS, A.M.I.E.E.

In crown 8vo, cloth gilt, 218 pp. 10s. 6d. net.

THERMIONIC VALVE CIRCUITS

By EMBRY WILLIAMS.

In demy 8vo, cloth, 174 pp., illustrated. 12s. 6d. net.

Sir Isaac Pitman & Sons, Ltd., Parker Street, Kingsway, W.C.2

CONTENTS

	PAGE
PREFACE	V
EXAMPLE	/
1. CAPACITANCE AND CONDENSERS	1
2. SELF-INDUCTANCE	6
3. SERIES CIRCUITS	8
4. PARALLEL AND COMPOUND CIRCUITS	12
5. SERIES RESONANCE	15
6. PARALLEL RESONANCE	18
7. RESONANCE CURVES AND DECREMENT	20
8. MUTUAL INDUCTANCE AND COUPLED CIRCUITS	22
9. DAMPED OSCILLATIONS	29
10. SPARK TRANSMITTERS	31
11. HIGH FREQUENCY ALTERNATORS	33
12. RECTIFICATION	33
13. VALVES AND THEIR CHARACTERISTICS	35
14. THE VALVE AS RECTIFIER	41
15. THE VALVE AS AMPLIFIER	44
16. THE VALVE AS GENERATOR	56
17. HETERODYNE RECEPTION	62
18. SUPERHETERODYNE RECEPTION	62
19. MODULATION	63
20. TRANSMITTERS	69
21. FREQUENCY CONTROL AND STABILIZATION	71
22. RECEIVERS	73
23. SELECTIVITY	75
24. FIELD STRENGTH	76
25. AERIAL RESISTANCE AND EFFICIENCY	77

EXAMPLE	SUBJECT	PAGE
26.	DIRECTIONAL TRANSMISSION AND RECEPTION	80
27.	RECEIVING AERIALS	83
28.	FRAME AERIALS	85
29.	AERIAL TUNING	88
30.	DIRECTION FINDING	89
31.	AERIAL STRESSES	91
32.	SHORT WAVES	93
33.	PROPAGATION	94
34.	INTERFERENCE	95
35.	REPRODUCERS AND MICROPHONES	95
36.	FILTERS AND ATTENUATORS	99
37.	POWER SUPPLIES	106
38.	TRANSMISSION LINES	106
39.	MEASUREMENTS	109
40.	MEASURING INSTRUMENTS	113
41.	A.C. BRIDGES	114
42.	CATHODE-RAY TUBES AND TIME BASES	117
43.	WAVEMETERS	119
44.	TELEVISION	120
45.	ACOUSTICS	121
46.	MISCELLANEOUS	122
47.	RADIO SERVICE WORK	125
	ANSWERS TO QUESTIONS	142

PROBLEMS IN RADIO ENGINEERING

1. CAPACITANCE AND CONDENSERS

Simple Parallel Plate Condenser

$$C = \frac{1.11\kappa A}{4\pi d} = \frac{0.088\kappa A}{d} \text{ micromicrofarads}$$

where A = area of each plate (sq. cm.),

d = distance apart (cm.),

κ = permittivity (or dielectric constant).

Multiple Plate Condenser

$$C = \frac{1.11\kappa A(N-1)}{4\pi d} = \frac{0.088\kappa A(N-1)}{d} \mu\mu\text{F.}$$

where N = total number of plates.

Composite Condenser

For a composite plate condenser made up of dielectrics of thickness d_1, d_2 , etc., having permittivities of κ_1, κ_2 , etc., respectively, these may be considered to be in series, and we have

$$C = \frac{0.088A}{(d_1/\kappa_1 + d_2/\kappa_2 + \dots)} \mu\mu\text{F.}$$

Concentric Cylindrical Condenser

$$C = \frac{0.24\kappa l}{\log(R/r)} \mu\mu\text{F.}$$

l = axial length in cm.

R = radius of outer cylinder

r = radius of inner cylinder

Self-capacitance of Single-layer Coil

$$C = 0.5R \text{ to } 0.75R \mu\mu\text{F.}$$

where R is the coil radius in cm.

Self-capacitance of Double Layer Coil

$$C = 0.18\kappa RL/D \mu\mu\text{F.}$$

where R is the radius, L the length, and D the distance between layers of the coil all in cm.

Energy Stored in a Condenser is

$$Q^2/2C = CV^2/2 = QV/2 \text{ joules}$$

when Q , C and V are expressed in coulombs, farads and volts respectively.

Power Loss

An imperfect condenser can be represented by a perfect condenser C either (a) in series with a low resistance r , or (b) in parallel with a high resistance R .

$$(a) \text{ Series.} \quad \tan \phi = 1/\omega Cr$$

$$\therefore \text{ power factor } \cos \phi = \frac{1}{\sqrt{[1 + 1/\omega^2 C^2 r^2]}} \doteq \omega Cr$$

$$\text{Power loss} = I^2 r = I^2 / \omega C \tan \phi = (I^2 / \omega C) \tan \delta$$

where δ is the dielectric loss angle = $(90 - \phi)$.

$$(b) \text{ Parallel.} \quad \tan \phi = \omega CR$$

$$\cos \phi = \frac{1}{\sqrt{[1 + \omega^2 C^2 R^2]}} \doteq 1/\omega CR$$

$$\text{Power loss} = V^2/R = V^2 \omega C / \tan \phi = V^2 \omega C \tan \delta$$

Condensers in Parallel and in Series

In parallel, total capacitance is given by

$$C = C_1 + C_2 + C_3 + \dots$$

Condensers in parallel share their charges.

In series, total capacitance C is given by

$$1/C = 1/C_1 + 1/C_2 + 1/C_3 + \dots$$

Potential Gradient

(a) Simple parallel condenser

$$g = V/D$$

where V is the p.d. between the plates and D their distance apart.

(b) Composite parallel condenser having a solid dielectric thickness d , permittivity κ , in contact with one plate.

Potential gradient in the air

$$g = \frac{V}{D - d(1 - 1/\kappa)}$$

(c) Cylindrical condenser. Potential gradient at radius x is

$$g = \frac{V}{x \log_h (R/r)}$$

where R and r are the outer and inner radii respectively.

Charge and Discharge

The voltage across a capacitance C in series with a resistance R at time t sec. after connection to a voltage V is

$$v = V(1 - e^{-t/CR})$$

During discharge $v = Ve^{-t/CR}$.

The time constant of the circuit is CR sec. and is the time taken for the condenser to charge up to 0.63 of its final voltage or to discharge down to 0.37 of its initial voltage.

EXAMPLES 1

1. Give details of the design of an oil condenser for a capacitance of 0.001 microfarad. The voltage limitations may be assumed to require a plate separation of $1\frac{1}{2}$ in. and the dielectric constant of the oil may be taken as 2. (*I.E.E.*, Oct., 1926.)

2. Describe the construction of a variable condenser suitable for receiving purposes. (*C. & G.*, 1, 1928.)

3. A transmitting condenser has a capacitance of 0.025 microfarad. Its power factor is 0.0005. What power is dissipated in the condenser when carrying a current of 200 amperes (r.m.s.) at a frequency of 25 000 c/s?

(*C. & G.*, 1, 1928.)

4. Describe, with sketches, the construction of one type of fixed condenser suitable for a radio transmitter.

(*C. & G.*, 1, 1929.)

5. What is meant by the "self-capacitance" of a coil? Describe some methods of measuring its value. What would be the approximate self-capacitance of a single layer solenoid 5 cm. radius and 10 cm. long? State the basis of your estimate.

(*I.E.E.*, Nov., 1929.)

6. Calculate the capacitance of a condenser formed by two long concentric circular cylinders of length l and radii R_0 and R_1 .

(*I.E.E.*, May, 1930.)

7. A condenser has five plates, each measuring 5 cm. by 2 cm. They are separated by mica plates 0.1 mm. thick and having a dielectric constant of 9. Calculate the capacitance in micromicrofarads.

(*I.E.E.*, May, 1930.)

8. Describe the construction of a fixed condenser suitable for high voltage and high frequency. A condenser of 2 microfarads capacity is charged to a potential difference of 1 000 volts. What is the amount of energy stored in the condenser? If this charged condenser is connected in parallel with an uncharged condenser of 3 microfarads capacity, what will be the potential difference and the total energy stored after connection? Explain the reason for any difference in the energy stored in the two cases.

(*C. & G.*, 1, 1932.)

9. Two parallel square metal plates, each of 20 cm. side, are separated by an air-gap of 1 cm. A slab of dielectric of permittivity 5 and thickness 5 mm. is placed between the plates and in contact with one of them. Calculate the capacitance of the condenser so formed. If the condenser is charged to a p.d. of 2 000 volts, calculate the voltage gradient in the air space.

(*I.E.E.*, Nov., 1932.)

10. A high frequency fixed type condenser consists of a number of parallel plates uniformly spaced and immersed in oil. It is desired to make the condenser suitable for higher voltage by doubling the spacing between the plates. Assuming that the modified condenser is worked at double the voltage previously used, compare in the two cases—

(a) the capacitances,

(b) the total volt-amperes taken by the condenser,

(c) the volt-amperes per unit volume of dielectric taken by the condenser.

(*C. & G.*, 1, 1933.)

11. What is meant by the permittivity of a dielectric? An air dielectric fixed condenser and inductance are found to resonate at a wave length of 500 metres. The condenser and

inductance are immersed in oil, and it is then found that they resonate at 750 metres. What is the permittivity of the oil?

(*C. & G., Prelim., 1935.*)

12. A condenser of eleven rectangular plates each 2 inches by 1 inch, separated by mica plates 4 mils thick, has a capacitance of 4 000 $\mu\mu\text{F}$. What is the dielectric constant of the mica?

(*I.E.E., May, 1935.*)

13. Find a formula for the capacitance of a parallel-plate condenser. The capacitance of a parallel-plate condenser is measured, and a slab of insulating material of thickness 0.5 cm. is introduced between the plates, which are then separated until the capacitance is restored to its original value. To do this it is found that the distance apart of the plates has to be increased by 0.34 cm. What is the permittivity of the insulating material?

(*I.E.E., Nov., 1935.*)

14. A variable condenser has a maximum capacitance of 1000 micromicrofarads and a minimum capacitance of 100 micromicrofarads. When in the maximum position it is charged to 1000 volts. The charging supply is then disconnected and the condenser turned to the minimum position. What was the original energy and the final energy stored in the condenser? Explain the reason for any difference.

(*C. & G., Prelim., 1936.*)

15. A condenser is being charged from a d.c. source through a resistance of two megohms. If it takes 0.5 second for the charge to reach three-quarters of its final value, what is the capacitance of the condenser? Prove any formula used.

(*I.E.E., May, 1936.*)

16. Describe the construction and explain the action of one type of electrolytic condenser. How does the working voltage affect the capacity? Why is a d.c. potential necessary?

(*C. & G., Prelim., 1937.*)

17. When a slab of insulating material of 0.4 cm. thickness is introduced between the plates of a parallel-plate condenser, it is found that the distance apart of the plates has to be increased by 0.35 cm. in order that the capacitance of the condenser shall be restored to its original value. What is the permittivity of the insulating material?

(*I.E.E., Nov., 1937.*)

18. The losses in a condenser can be represented by either a series resistance r or a shunt resistance R . Deduce an expression for the relationship between the two equivalent resistances. If the product of the equivalent series resistance and capacitance of a condenser at a certain frequency is 20×10^{-10} , and the power factor is 0.001, at which frequency was the measurement made?

(*C. & G., 2, 1940.*)

2. SELF-INDUCTANCE

REFERENCES. *Electric Circuits and Wave Filters*, by Starr (Pitman); *Admiralty Handbook of Wireless Telegraphy* (H.M. Stationery Office); *Radio Frequency Measurements*, by Moullin (Griffin).

Wire, h cm. above Earth

$$L = 0.0046l \log(2h/r) \mu\text{H. when } l > 2h$$

$$\text{and } L = 0.0046l \log(2l/r) \mu\text{H. when } l < 2h$$

where l cm. is the length and r cm. is the radius of the wire.

Single-layer Coil

$$L = 0.0098d^2N^2k/l \mu\text{H.}$$

where N is the number of turns, l cm. the length and d cm. the diameter of the coil, and k is Nagaoka's constant which depends upon d/l and is given in the following table—

d/l	0	0.1	0.2	0.5	1	2	5	10
k	1	0.96	0.92	0.82	0.69	0.53	0.32	0.20

Toroid or Long Solenoid

If d/l is small and the coil is air-cored,

$$L = 0.0098 d^2N^2/l \mu\text{H.}$$

$$= 0.0098 d^2n^2l \mu\text{H.}$$

where n is the number of turns per cm. length.

If the core has a permeability μ ,

$$L = 0.0098 d^2n^2\mu l \mu\text{H.}$$

Multi-layer Coil

$$L = \frac{0.023 N^2d(1 - 2.25 c/d)}{1 + 2.3 l/d} \mu\text{H.}$$

where d is the outside diameter, c the radial depth, and l the length of the coil all in cm.

Inductances in Series and in Parallel

In series, the total inductance is given by

$$L = L_1 + L_2 + L_3 + \dots$$

In parallel, the total inductance L is given by

$$1/L = 1/L_1 + 1/L_2 + 1/L_3 + \dots$$

Growth and Decay of Current

The current at any time t after connection to a voltage V in a circuit of inductance L and resistance R is

$$i = (V/R)(1 - e^{-Rt/L})$$

The decay of the current is given by

$$i = (V/R)e^{-Rt/L}$$

The time constant of the coil is L/R sec.

The reactance of an inductance L is ωL .

The dynamic resistance of a coil having inductance L , resistance R and self-capacitance C is L/CR .

EXAMPLES 2

1. A glass tube 3 cm. in diameter is bent round to form a ring of 20 cm. diameter, and the tube is then wound uniformly with 500 turns of wire. Calculate the inductance of the toroid so formed, proving any formula used. (*C. & G., Final, 1927.*)

2. A single layer solenoid is 6 cm. diameter and 24 cm. long, and is wound uniformly with 10 turns of wire per cm. of length. Calculate the approximate inductance in microhenries of the coil, and state, with reasons, whether you consider your calculation is an over or an under estimate.

(*I.E.E., Nov., 1929.*)

3. What is meant by the terms self-induction and reactance? Two coils have self-inductance of 5 henries and 10 henries respectively. What will be their reactance at a frequency of 50 cycles per second when connected (a) in series, (b) in parallel?

(*C. & G., 1, 1932.*)

4. A wooden ring has a mean diameter of 15 cm. and a circular cross-section of diameter 2 cm. It is wound uniformly with one layer, and the winding has 30 turns per cm. Calculate the inductance of this toroidal coil. (*I.E.E., Nov., 1932.*)

5. State the methods which are adopted to reduce the self-capacitance of receiving inductances. In two similar coils

having the same number of turns, the linear dimensions of one coil are in all cases double the corresponding dimensions of the other. How will their inductances compare?

(*C. & G., Prelim., 1934.*)

6. A relay with an inductance of 3.0 henries and a resistance of 180 ohms operates with 1 milliamperere. What time will elapse before the relay commences to operate after a potential difference of 0.25 volt is established across its terminals? Prove any formula used.

(*I.E.E., Nov., 1934.*)

7. A glass tube 4 cm. in diameter is formed into a ring of 25 cm. diameter, and the tube is wound uniformly with 750 turns of wire. Find the inductance of the toroid formed in mH., proving any formula used.

(*I.E.E., May, 1935.*)

8. An impulsing relay, having a resistance of 600 ohms and an inductance of 1.8 henries, is adjusted to operate with a current of 20 mA. What will be the operating lag of the relay when it is connected in series with a non-inductive resistance of 1000 ohms and a battery of 48 volts?

(*I.E.E., Nov., 1936.*)

9. An inductance coil has an inductance of 0.025 henry. When a 100 volt 50 cycle potential is impressed across the coil the current flowing is 10 A. What are the resistance and the power factor of the coil?

(*C. & G., Prelim., 1937.*)

10. What is meant by the time-constant of a circuit? A 50-volt battery, a 100-ohm resistance, and coil having an inductance of 4 henries and a resistance of 100 ohms, are connected in series. Find (a) the current after a period equivalent to the time-constant of the coil, and (b) the rate at which the current will then be increasing.

(*I.E.E., May, 1937.*)

11. The current in a circuit comprising resistance and inductance can be represented by the expression $i = (E/R)(1 - e^{-Rt/L})$. If $E = 120$ volts, $R = 60$ ohms, $L = 0.12$ henry, $e = 2.71$, plot a curve showing the value of i as t varies from 0 to 0.004 second. From your curve find the time taken for the current to reach 1.26 amp.

(*C. & G., 1, 1939.*)

3. SERIES CIRCUITS

The more important formulae for use with series circuits are given in the following table. Although the use of vector operators is not essential in series circuits they are given here as an alternative to the scalar quantities to make them

familiar to the student. The use of vector operators when dealing with parallel circuits is essential.

Reactance of a resistance R	R	R
" " an inductance L	ωL	$j\omega L$
" " a condenser C	$1/\omega C$	$1/j\omega C = -j/\omega C$
Impedance Z of R, L, C in series	$\sqrt{[R^2 + (\omega L - 1/\omega C)^2]}$	$R + j\omega L - j/\omega C$
Current I in circuit	V/Z	V/Z
Voltage across resistance	IR	IR
" " inductance	ωLI	$j\omega LI$
" " condenser	$I/\omega C$	$-jI/\omega C$
Power factor	R/Z	
Resonant frequency	$1/2\pi\sqrt{LC}$	
Impedance at resonance	R	

EXAMPLES 3

1. A current of 1 ampere, frequency 100 000 cycles per sec. is passed through a coil of resistance 20 ohms and inductance 400 microhenries. What is the voltage across the coil?

(*C. & G.*, 1, 1926.)

2. A current of 0.5 ampere, frequency 159 000 cycles per sec., is passed in series through a condenser of 1 000 microfarads and an inductance of 800 microhenries. Find the voltage across each and across the two together. Resistances may be neglected.

(*C. & G.*, 1, 1927.)

3. If the potential difference across a condenser and a resistance in series is given by the expression $v = 25 \sin 10^4 t$, and the current through by $i = 10 \sin (10^4 t + 30^\circ)$, what are the values of the condenser and the resistance?

(*I.E.E.*, Oct., 1927.)

4. What is understood by the statement that the impedance of a circuit is $R + jX$? If the resistance of a series circuit is 15 ohms, the inductance is 800 microhenries and capacitance 1 000 micromicrofarads, draw a diagram from which the impedance of the circuit at frequencies round about resonance can be read off.

(*I.E.E.*, Oct., 1927.)

5. An alternating voltage of 100 volts (r.m.s.) at a frequency of 100 000 cycles is applied to a circuit consisting of a coil of 1 500 microhenries inductance, a condenser of 0.007 microfarads capacitance, and a resistance of 25 ohms, all connected in series. Find the value and phase angle of the resulting current.

(*C. & G.*, Final, 1928.)

6. A transmitting aerial is tuned to 600 m. by a series

inductance of 200 microhenries. What is the voltage at the leading-out insulator when the aerial is supplied with 20 amperes (r.m.s.) at this wavelength? (*C. & G.*, 1, 1929.)

7. A condenser, resistance, and inductance are connected in series across an alternating current supply of 100 volts, 500 cycles. If the capacitance of the condenser is 2 microfarads, the inductance is 1 henry and the resistance is 10 ohms, what is the current flowing in the circuit, and what is the voltage across each item? (*C. & G.*, 1, 1929.)

8. A circuit consisting of a coil, a variable condenser, and a thermo-couple is lightly coupled to a variable frequency power oscillator. A galvanometer is connected to the couple. The circuit is in resonance when the oscillator is adjusted to 1 000 m. When the oscillator is adjusted to 1 005 m., the galvanometer deflection is halved. If the capacitance of the condenser is 0.0015 microfarad, what is the resistance of the circuit? (*C. & G.*, *Final*, 1929.)

9. In a transmitting circuit two condensers in series carry a high frequency current of 100 amperes, r.m.s. The capacitances of the condensers are 0.025 and 0.015 microfarad. If the wavelength of the transmitter is 5 000 m., what is the voltage across each condenser? (*C. & G.*, 1, 1930.)

10. What is the current in a circuit consisting of an inductance of 1.5 henries, a resistance of 100 ohms, and a condenser of 20 microfarads all in series, when subjected to an impressed e.m.f. of 100 volts r.m.s. at 50 cycles per sec. (*C. & G.*, 1, 1930.)

11. A coil of inductance 2 mH. and resistance 20 ohms is connected in series with a condenser of capacitance $500\mu\mu\text{F}$. An e.m.f. of value 1 volt is induced in the circuit. Calculate the p.d. across the condenser when this e.m.f. has a frequency of (a) 158 kc. per sec., and (b) 150 kc. per sec. (*I.E.E.*, *May*, 1930.)

12. A condenser of $4\mu\text{F}$. is connected in series with a resistance of 400 ohms. This combination is connected in series with two inductances in parallel of values 10 henries and 5 henries respectively. What current will flow through the resistance when an e.m.f. of 100 volts r.m.s. at 50 periods per sec. is applied to the circuit? (*C. & G.*, 1, 1931.)

13. A condenser of 2 microfarads, a resistance of 50 ohms, and an inductance of 6 henries are connected in series. What current will flow when an e.m.f. of 200 volts r.m.s. at 50 periods per sec. is applied to the circuit? (*C. & G.*, 1, 1932.)

14. What is the impedance at a frequency of 900 kc. per sec. of a circuit consisting of a condenser of 0.0002 microfarad capacitance in series with a coil of 200 microhenries inductance and 25 ohms resistance? (*C. & G.*, *Prelim.*, 1934.)

15. A circuit consisting of a resistance of 50 ohms, an inductance of 10 henries and a capacitance of 1 microfarad in series is found to pass 1 ampere with a certain applied e.m.f. alternating at 50 cycles per second. What will it pass with the same e.m.f. alternating at 100 cycles per second?

(*C. & G., Prelim., 1935.*)

16. An e.m.f. of constant amplitude but variable frequency is induced in a circuit consisting of inductance, capacitance and resistance in series. Show that the vector locus of the current in the circuit is a circle. (*I.E.E., May, 1935.*)

17. At a frequency of 796 cycles per second, an e.m.f. of 6 volts sends 100 mA. through a certain circuit. When the frequency is raised to 2 866 cycles per second, the same voltage sends only 50 mA. through the same circuit. Of what does the circuit consist? (*I.E.E., May, 1936.*)

18. A series circuit has a resistance of 20 ohms, an inductance of $400\mu\text{H.}$, and a capacitance of $320\mu\text{F.}$ Draw the vector locus of the current when an e.m.f. of 10 volts at varying frequency acts in the circuit. From the vector locus find (a) the resonant frequency, (b) the frequencies at which the current is one-half its maximum value. (*I.E.E., May, 1936.*)

19. A coil of constant inductance is connected to an alternating supply of 100 c/s and the current flowing is noticed. When a 4-microfarad condenser, of negligible resistance, is joined in series with the coil the value of the current is the same as before. Calculate the inductance of the coil. If the coil has a resistance of 600 ohms find the total impedance of the circuit. (*I.E.E., Nov., 1937.*)

20. A resistance of 10 000 ohms and a condenser of 0.01 microfarad are connected in series. If 100 volts at a frequency of 1 kc/s are applied across the circuit, what is the potential across (a) the resistance, and (b) the condenser? Find the value of the tangent of the angle between the applied voltage and the voltage across the resistance.

(*C. & G., 1, 1938.*)

21. The impedance of a series circuit consisting of resistance and inductance is 200 ohms when the frequency is 500 kc/s. If the value of the resistance is 100 ohms, what is the value of the inductance? (*C. & G., 1, 1940.*)

22. The voltage across a circuit consisting of an inductance and a resistance in series is 100 volts. If the resulting voltage across each of the components is the same, what is the value of this voltage? Explain your answer by means of a diagram.

(*C. & G., 1, 1941.*)

4. PARALLEL AND COMPOUND CIRCUITS

The effective impedance Z of impedances Z_1, Z_2 , etc., in parallel is given by the vector equation

$$1/Z = 1/Z_1 + 1/Z_2 + \dots$$

Each impedance in this equation is in the form of an operator $Z = r + jx$, where r is the total resistance and x is the equivalent reactance of the circuit.

Expressed in the polar form, this may be written

$$\begin{aligned} Z &= \sqrt{(r^2 + x^2)} \angle \tan^{-1}(x/r) \\ &= z \angle \phi \end{aligned}$$

where

$$r = z \cos \phi$$

$$x = z \sin \phi.$$

EXAMPLES 4

1. Find an expression for the effective impedance of two circuits in parallel, one consisting of a condenser C and a resistance R_c , and the other of an inductance L having a resistance R_l . Show that at wireless frequencies the locus of the impedance is very nearly a circle of diameter $L/C(R_l + R_c)$.

(*I.E.E.*, Oct., 1927.)

2. Two impedances having values of $80/30^\circ$ ohms and $24 + j70$ ohms are paralleled. What is the value of the resultant impedance expressed as the sum of real and imaginary quantities? What is the value of its modulus?

(*C. & G.*, *Final*, 1929.)

3. A coil of inductance L and resistance R is connected in parallel with a condenser of capacitance K : these two together are connected in series with a condenser of capacitance C and a source of sinoidal applied voltage. Find the apparent input resistance of the whole system when the frequency $n = p/2\pi$ is such that $p^2L(C + K) = 1$.

(*I.E.E.*, Nov., 1929.)

4. A coil of inductance 5 mH. and resistance 50 ohms is joined in parallel with a condenser of $508 \mu\mu F$. capacitance: these two together are joined in series with a non-inductive resistance of 50 000 ohms to a source of alternating p.d. of magnitude 1 volt and frequency 100 kilocycles per sec. Calculate the p.d. between the terminals of the condenser.

(*I.E.E.*, Nov., 1929.)

5. A circuit consists of a condenser of 10 microfarads capacitance which is joined in series with a combination of an inductance of 0.5 henry in parallel with a resistance of 300 ohms. What is the value and phase angle of the current in the condenser when an applied e.m.f. of 250 volts r.m.s. at 100 cycles per sec. is applied to the circuit?

(*C. & G., Final, 1930.*)

6. A coil is wound with very fine stranded wire, and at low frequencies it is found to have an inductance of 3.2 mH. and a resistance of 100 ohms. It has a self-capacitance of $32 \mu\mu\text{F}$. Calculate the apparent inductance and resistance for currents the frequency of which corresponds to a wave length of 600 m.

(*I.E.E., May, 1930.*)

7. Find the values of the non-inductive resistance and non-resistive inductance which, when connected in parallel, have the same impedance at a given frequency as a coil of inductance L and resistance R .

(*I.E.E., May, 1930.*)

8. A non-inductive resistance of 10^5 ohms is connected in the anode circuit of a rectifier valve, and is shunted by a bypass condenser of $500 \mu\mu\text{F}$. capacitance. A modulated signal, the carrier wave of which has a length of 300 m., is applied between grid and filament of the valve. Calculate the impedance of the combination to the carrier frequency and also to currents of frequency (a) 5 kc. per sec.; and (b) 100 cycles per sec.

(*I.E.E., May, 1930.*)

9. A coil of inductance 1 mH. and resistance 10 ohms is connected in parallel with a condenser of $80 \mu\mu\text{F}$. capacitance, and a p.d. of 1 volt at a frequency of 750 kc. per sec. is applied to the terminals of the combination. Find the current in the coil, the current in the condenser, and also the current from the source.

(*I.E.E., May, 1930.*)

10. Explain the term "self-capacitance" of a coil. A certain coil has an inductance of 5 mH. and a self-capacitance of $5 \mu\mu\text{F}$. What will be its effective resistance and inductance at a frequency corresponding to a wavelength of 600 m., if the high frequency resistance of the windings is 100 ohms? Find the effective power factor of the coil at this frequency.

(*I.E.E., Nov., 1931.*)

11. How would you measure the self-capacitance of a coil? A coil of 3 mH. inductance has a self-capacitance of $10 \mu\mu\text{F}$.: if the apparent resistance is 70 ohms at a wavelength of 1 000 m., calculate the resistance it would have in the absence of self-capacitance.

(*I.E.E., Nov., 1932.*)

12. A resistance of 1 500 ohms and an inductance of 5 henries are connected in parallel across a 50 cycles per sec. alternating

current supply of 1 000 volts r.m.s. What will be the total current taken from the mains? (*C. & G.*, 1, 1933.)

13. An alternating voltage of 100 volts (r.m.s.) at 50 periods per sec. is applied to a circuit consisting of a condenser of 2 microfarads in parallel with a coil having an inductance of 5 henries and a resistance of 100 ohms. What will be the amplitude and phase of the current through the inductance, and the amplitude and phase of the current taken from the mains? (*I.E.E.*, May, 1933.)

14. A circuit consists of two branches in parallel. One branch consists of an inductance L in series with a resistance R ; the other branch consists of a condenser C in series with a resistance R . If $\sqrt{L/C} = R$, prove that the impedance of the circuit is independent of frequency and equal to R .

(*C. & G.*, Final, 1933.)

15. A condenser of 2 microfarads is shunted by a variable resistance. Draw the vector locus of the impedance of the parallel circuit at a frequency of 796 cycles per second as the resistance is varied from zero to infinity. From the locus read off the impedance when the resistance has values of 100 ohms and 250 ohms. (*I.E.E.*, Nov., 1934.)

16. A coil with an impedance of $20 + j50$ has induced in it an e.m.f. of 10 volts. Across the coil are connected two circuits in parallel, the impedances of which are $100 + j0$ and $60 - j40$ respectively. Find the current which flows in the coil.

(*I.E.E.*, May, 1936.)

17. A circuit includes two sections AB and BC in series. The section AB consists of two branches in parallel. The first of these is formed of a non-inductive resistance of 60 ohms in series with a condenser of 50 microfarads, whilst the second consists of a resistance of 60 ohms having an inductance of 250 millihenries. The section BC consists of a resistance of 100 ohms having an inductance of 300 millihenries. The frequency of the current is 50 cycles per second. The voltage across the section AB is 500 volts. What is the voltage across the section BC ?

(*I.E.E.*, Nov., 1936.)

18. The arms of a T-network $ABC-BD$ are as follows: AB and BC each consist of a coil having a resistance of 40 ohms, and an inductance of 4 mH., and BD is a 10-microfarad condenser. Across A and D is established a p.d. of 6 volts at a frequency of 796 c/s. Find the current in a resistance of 40 ohms connected across C and D and its phase angle with regard to the applied potential difference.

(*I.E.E.*, May, 1937.)

19. An inductance of $1/\pi$ mH. and a capacitance of $0.1/\pi$

microfarad are connected in parallel across an a.c. supply. If the frequency is 100 kc/s and the value of the current in the inductance arm is 1 ampere, find (a) the voltage across the parallel circuit, (b) the current in the capacitance arm, (c) the total current in the common external circuit.

(C. & G., 1, 1939.)

5. SERIES RESONANCE

REFERENCES. *Radio Frequency Measurements*, by Moullin (Griffin); *Admiralty Handbook of Wireless Telegraphy* (H.M. Stationery Office); *Wireless*, by Turner (Cambridge Univ. Press); *Radio Engineering*, by Terman (McGraw-Hill); *Principles of Radio Engineering*, by Glasgow (McGraw-Hill).

The condition for resonance is that the reactance must be zero.

This is achieved in a simple series L, C, R circuit when

$$\omega^2 = 1/LC,$$

in which case the impedance $Z = R$ and the current is a maximum.

If V is the applied voltage, the current $I = V/R$ and the voltages across the coil and across the condenser

$$= V\omega L/R = V/\omega CR$$

The magnification factor $Q = 1/\omega CR = \omega L/R$.

In a composite circuit the condition for resonance is determined by finding the total vector impedance in the cartesian form $R + jX$, and equating the imaginary component, i.e. X , to zero.

Practical formulae for the determination of the resonant frequency are

$$f = 159.2/\sqrt{LC} = 300/\lambda$$

where $\lambda = 1.885\sqrt{LC}$

and $\lambda f = 300$.

Here, f is in megacycles per sec., λ in metres, L in microhenries, and C in micromicrofarads.

EXAMPLES 5

1. A condenser having a capacity of 800 micromicrofarads

and a resistance of 1.5 ohms is connected across a coil having an inductance of 1 500 microhenries and a resistance of 8.5 ohms, and an e.m.f. of 10 volts is induced in the coil. Find the frequency of the e.m.f. which will produce the largest current in the circuit and the value of the current when the frequency has this value. (C. & G., 1, 1926.)

2. An inductance and condenser are connected in series and are found to resonate at a wavelength of 750 metres. A second condenser of $250 \mu\mu\text{F}$. capacitance is connected in parallel with the first condenser, and the circuit now resonates at 1 000 m. What is the value of the inductance and the capacitance of the first condenser? (C. & G., 1, 1930.)

3. An alternator generating 500 volts r.m.s. at a frequency of 100 cycles per sec. has an armature, the inductance of which is 0.25 henry. What power will it deliver into a resistance of 100 ohms? Can this power be increased by the use of a condenser? If so, how should the condenser be connected and what is the value of its capacitance? What power will be delivered to the resistance with the condenser in use? (C. & G., 1, 1930.)

4. What is meant by resonance in a circuit? What is a resonance curve? How is the resonance curve of a circuit affected by resistance? A condenser of $1000 \mu\mu\text{F}$. is connected in series with an inductance of 500 μH . What is the wavelength at which this circuit would resonate? If an additional condenser of $250 \mu\mu\text{F}$. is connected in series, what will be the wavelength of resonance? (C. & G., 1, 1931.)

5. A coil of 2 mH. inductance is shunted by a capacitance of 2 000 $\mu\mu\text{F}$. These two together are connected in series with an inductance of 4 mH., and an alternating p.d. is applied to the combination. Find the frequency of this p.d. to which the compound circuit will be in acceptor resonance. (I.E.E., May, 1931.)

6. If each coil in Q. 5 has a resistance of 10 ohms at the resonant frequency, find the apparent input resistance of the combination. (I.E.E., May, 1931.)

7. Two low-decrement coils, each of inductance 5 mH., are connected in series with one another. A capacitance of $500 \mu\mu\text{F}$. is connected across one coil and a capacitance of $400 \mu\mu\text{F}$. across the other coil. Find the frequency at which the network is in acceptor resonance, and sketch the resonance curve between frequencies of about 50 and 150 kc. per sec. (I.E.E., Nov., 1931.)

8. An inductance L , having a resistance R , is joined in parallel with a capacitance C ; these two together are in series

with an inductance L having a resistance R . Find the effective resistance and reactance of the combination when the frequency is such that $\omega^2 = 1/LC$. (*I.E.E., May, 1932.*)

9. How would you determine the natural wavelength of a coil? An oscillatory circuit containing a thermo-milliammeter is weakly coupled to a power oscillator and tuned to resonance when the reading of the thermo-milliammeter is 20 milliamperes. A resistance of 5 ohms is then added in series with the resonant circuit and the current becomes 4 milliamperes. What is the resistance of the circuit? If damped oscillations had been generated in the circuit itself by means of a buzzer and the current without the added resistance had been 20 milliamperes, what would have been the reading when the resistance of 5 ohms was inserted? (*C. & G., Final, 1933.*)

10. Explain why the ratio $\omega L/R$ is known as the magnification of an oscillatory circuit. Show how to find the effect on the magnification of a high resistance shunting the oscillatory circuit. If the inductance and resistance of an oscillatory circuit, tuned to 300 m., are $150\mu\text{H}$. and 10 ohms respectively, find the magnification when the condenser is shunted by a resistance of 50 000 ohms. (*I.E.E., Nov., 1935.*)

11. A tuned circuit consists of a condenser of $0.0005\mu\text{F}$. capacitance and an inductor of 1 mH. What is the wavelength to which it will resonate? What will be the effect on the wavelength of adding a condenser of $0.0003\mu\text{F}$. in series with the original condenser, and an inductor of 0.4 mH. in parallel with the original inductor? (*C. & G., Prelim., 1936.*)

12. A series tuned circuit has a capacitance of 0.2 microfarad; what must be its inductance, in order that resonance shall occur at a frequency of 500 kc/s? What is the effect of resistance on the frequency/amplitude response curve of such a circuit? (*C. & G., 1, 1938.*)

13. A resistor, condenser, and variable inductor are connected in series across a 200-volt 50 c/s a.c. supply. The maximum current which can be obtained by varying the inductance is 314 mA., and the voltage across the condenser is then 300 volts. Calculate the capacitance of the condenser and the values of the inductance and resistance. (*I.E.E., May, 1938.*)

14. The capacitance of a condenser used for tuning a receiver can be varied between 30 and 300 micromicrofarads. If the inductance is 100 microhenries, what is the approximate tuning range of the receiver? (*C. & G., 1, 1940.*)

15. When an inductance and resistance are connected in series it is found that the current passing at a fixed frequency of 100 kc/s is half that passing when the resistance alone is in

circuit, the applied voltage remaining constant. What is the power factor of the inductance/resistance circuit? If the value of the resistance is 100 ohms, what must be the value of the capacitance needed in series with the inductance and resistance to restore the current to the same value as when the resistance alone was in circuit? (C. & G., 2, 1941.)

6. PARALLEL RESONANCE

REFERENCES. *Radio Frequency Measurements*, by Moullin; *Admiralty Handbook of Wireless Telegraphy*; *Radio Engineering*, by Terman; *Principles of Radio Engineering*, by Glasgow.

The condition for resonance is the same as that for an acceptor circuit, viz. that the reactance must be zero.

In a simple circuit having two parallel branches, one containing a capacitance C and the other an inductance L in series with a resistance R , this occurs when

$$\omega^2 = (1/LC) - (R^2/L^2) \doteq 1/LC$$

if R is small.

The effective or dynamic resistance of the circuit at resonance

$$= L/CR = \omega^2 L^2/R$$

In more involved circuits the resonant condition is determined by finding the total vector impedance and equating the imaginary component to zero.

If a network has no resistance it will be a stopper circuit when the reactance is a maximum.

EXAMPLES 6

1. An alternating current of 5 milliamperes divides between a condenser and a coil connected in parallel. If the condenser has a capacity of 350 micromicrofarads and a negligible series resistance whilst the coil has an inductance of 250 microhenries and an effective resistance of 12 ohms, at what frequency will the voltage across the combination be a maximum, and what will be the value of this maximum voltage?

(L.U., 1926.)

2. A condenser of 0.004 microfarad is shunted by an inductance of 1 000 microhenries having a high frequency resistance of 30 ohms. A voltage of 0.5 volt (r.m.s.) is applied across the terminals of the condenser at the resonant frequency of the circuit. Find the values of the currents in the condenser, in the inductance, and in the supply circuit.

(*C. & G., Final, 1928.*)

3. The anode current of a valve generator contains a fundamental component of frequency 500 kc. per sec. and amplitude 10 mA. The anode circuit consists of a coil of 500 μ H. inductance and decrement 2 per cent, shunted by a condenser. Calculate the value of the current in this tuned oscillatory circuit.

(*I.E.E., May, 1930.*)

4. A compound impedance consists of three parallel branches. The first branch is an inductance of 1 mH., the second is an inductance of 1 mH. in series with a capacitance of 1 000 $\mu\mu$ F., and the third is a capacitance C . Find the value of C in order that the whole may be in stopper-circuit resonance to a frequency of 80 kilocycles per sec.

(*I.E.E., Nov., 1932.*)

5. One branch of a parallel circuit consists of an inductance of 80 mH having a resistance of 6 ohms, and the other branch consists of a condenser of capacitance 2.0 μ F. and negligible resistance. What is the impedance of the circuit at the resonance frequency and at frequencies 5 per cent greater than and 5 per cent less than the resonance frequency?

(*I.E.E., May, 1935.*)

6. A parallel circuit consists of two arms, one containing resistance and inductance in series, the other containing capacitance. The impedance across the circuit at resonant frequency is measured. The three elements are then placed in series and the impedance at resonant frequency again measured. The impedance in the first case was found to be much higher than in the second case. Explain these facts by the aid of vector diagrams. If the values of the two impedances were 10 000 ohms and 100 ohms respectively, calculate the ratio of the inductance and capacitance. (*C. & G., 2, 1939.*)

7. The oscillatory circuit of a wavemeter consists of a variable condenser of capacitance C in series with a coil of inductance L and resistance R . Explain why at a given frequency the setting of the condenser for resonance is not the same when employing a voltage-detector as it is when employing a current-detector. If $L = 400$ microhenries and $R = 90$ ohms, determine the capacitance values required to give current and voltage resonance at a frequency of 0.25 Mc/s.

(*I.E.E., May, 1940.*)

7. RESONANCE CURVES AND DECREMENT

The decrement δ of an L, C, R circuit is given by

$$\delta = R/2fL = \pi R/\omega L = \pi R\omega C = \pi R\sqrt{C/L}$$

$$\div \pi \text{ (power factor of coil)}$$

In a resonance curve, let I = current at resonant frequency f . Let the current be I/k , at two frequencies f_1 and f_2 on either side of f .

Then the decrement

$$\delta = \frac{\pi}{m} \left(\frac{f_1 - f_2}{f} \right)$$

where

$$m = \sqrt{(k^2 - 1)}.$$

If $k = \sqrt{2}$, $m = 1$, and we have $\delta = \pi \left(\frac{f_1 - f_2}{f} \right)$

If C is varied instead of f , $\delta \div \frac{\pi}{2} \left(\frac{C_1 - C_2}{C} \right)$

EXAMPLES 7

1. Explain, giving experimental details, how to obtain the resonance curve of an oscillatory circuit with a natural frequency of about a million. Show how to obtain the decay factor or logarithmic decrement of the circuit from the curve.

(*L.U.*, 1926.)

2. What is meant by resonance and resonance curves in wireless circuits? How would you proceed experimentally to draw a simple resonance curve?

(*C. & G.*, 1, 1927.)

3. Give details of an experimental method of drawing the resonance curve of an oscillatory circuit with a natural frequency of about a million cycles per sec. Show how to find the decay factor of the circuit from the curve.

(*C. & G.*, *Final*, 1927.)

4. Give an account of an experimental method of drawing the resonance curve of an oscillatory circuit with a natural frequency of about a million cycles per sec. Show how to find the decay factor of the circuit from the curve.

(*I.E.E.*, *Oct.*, 1927.)

5. The resonance curve, connecting current and frequency, is plotted for a simple inductance, resistance, capacitance circuit. Prove that the decrement of the circuit is π times the fractional width of the resonance curve at $1/\sqrt{2}$ of its maximum height.
(*I.E.E., Nov., 1929.*)

6. If a resonant circuit of natural frequency f_0 has induced in it a constant e.m.f. of varying frequency, there will be found two frequencies f_1 and f_2 above and below f_0 at which the current in the circuit is half the value of the current at f_0 . Show that

$$f_1 \times f_2 = f_0^2 \quad \text{and} \quad f_1 - f_2 = (\sqrt{3})R/2\pi L$$

(*C. & G., Final, 1930.*)

7. A simple L, C, R circuit is acted on by an e.m.f. of constant amplitude but varying frequency. Show that the power factor of the circuit is equal to the fractional width of the resonance curve measured at $1/\sqrt{2}$ of its maximum height.

(*I.E.E., Nov., 1932.*)

8. A tuned circuit consists of a condenser of 1,000 $\mu\mu\text{F}$. capacitance, and a coil of 0.3 mH. inductance and 40 ohms resistance. If f_0 is the frequency of resonance, compute and plot on squared paper the resonance curve between $0.9 f_0$ and $1.1 f_0$. What is the band width in cycles at half the peak response?
(*C. & G., Inter., 1935.*)

9. Derive an expression for the width of response of a resonant circuit at $1/\sqrt{2}$ of the amplitude at resonance, under a constant applied e.m.f. in terms of the equivalent decrement of the circuit.
(*C. & G., Final, 1936.*)

10. In order to measure the resistance of a coil of negligible self-capacitance it is connected in series with a thermomilliammeter of 9 ohms heater resistance across a variable condenser. The circuit is then weakly coupled to a high-frequency source of 1 megacycle per second. When the condenser is tuned to resonance, a current of 10 mA. flows in the circuit. The condenser is then adjusted above and below the resonance frequency, until the current is 7.07 mA. The values of the condenser to give this current are 450 and 650 micromicrofarads respectively. What is the resistance of the coil?

(*C. & G., Inter., 1937.*)

11. A coil of unknown resistance and inductance is connected in parallel with a low-loss variable air condenser, and the circuit so formed is made resonant at a frequency of 1 Mc/s by adjusting the condenser to a capacitance value

of 200 micromicrofarads. It is found that the circuit current falls to $1/\sqrt{2}$ of the value at resonance on changing the capacitance to 198 micromicrofarads. Calculate the inductance, resistance, and power factor of the coil at the frequency in question. (I.E.E., Nov., 1940.)

8. MUTUAL INDUCTANCE AND COUPLED CIRCUITS

REFERENCES. *Telegraphy and Telephony*, by Mallet (Chapman & Hall); *Wireless*, by Turner (Cambridge Univ. Press); *Principles of Radio Engineering*, by Glasgow; *Radio Engineering*, by Terman.

The e.m.f. induced in a circuit which is coupled by a mutual inductance M to another circuit in which a varying current flows is given by

$$e = M(di/dt) \text{ or } E = \omega MI$$

or vectorially $E = j\omega MI$

If two inductances, L_1 and L_2 , having a mutual inductance M , are connected together, their joint inductance will be

(a) In series aiding $L_1 + L_2 + 2M$

(b) In series opposing $L_1 + L_2 - 2M$

(c) In parallel aiding $\frac{L_1 L_2 - M^2}{L_1 + L_2 - 2M}$

(d) In parallel opposing $\frac{L_1 L_2 - M^2}{L_1 + L_2 + 2M}$

Mutual Inductance Coupling: (Fig. 1)

Coefficient of coupling $k = M/\sqrt{(L_1 L_2)}$

Equivalent resistance $R = R_1 + R_2(\omega M/Z_2)^2$

Equivalent reactance $X = X_1 - X_2(\omega M/Z_2)^2$

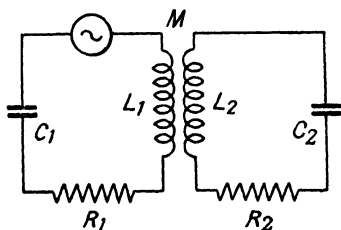

(FIG. 1)

Internal Inductance Coupling: (Fig. 2)

$$k = \frac{L}{\sqrt{[(L + L_1)(L + L_2)]}}$$

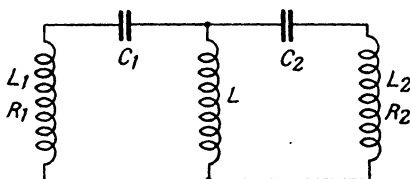

(FIG. 2)

External Inductance Coupling: (Fig. 3)

$$k = \sqrt{\left[\frac{L_1 L_2}{(L + L_1)(L + L_2)} \right]}$$

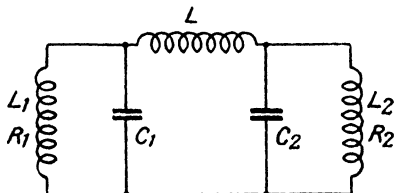

(FIG. 3)

Internal Capacitance Coupling: (Fig. 4)

$$k = \sqrt{\left[\frac{C_1 C_2}{(C + C_1)(C + C_2)} \right]}$$

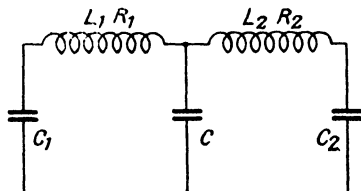

(FIG. 4)

External Capacitance Coupling: (Fig. 5)

$$k = \frac{C}{\sqrt{[C + C_1](C + C_2)}}$$

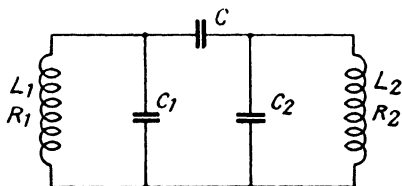

(FIG. 5)

Secondary Current with Mutual Inductance Coupling

The secondary current at resonance in a pair of tuned inductively-coupled circuits is

$$I_2 = \frac{E}{\omega M \{1 + (R_1 R_2 / \omega^2 M^2)\}}$$

This is a maximum at critical coupling, i.e. when

$$\omega^2 M^2 = R_1 R_2$$

or

$$k^2 = 1/Q_1 Q_2$$

The maximum current = $E/2\omega M = E/2\sqrt{(R_1 R_2)}$. The corresponding primary current = $E/2R_1$.

If $k > 1/\sqrt{Q_1 Q_2}$, there are two peaks of secondary current; if the circuit resistances are each equal to R , each peak has a height $I = E/2R$.

The frequency width between the peaks is

$$f_p = f\sqrt{[k^2 - \frac{1}{2}\{(1/Q_1^2) - (1/Q_2^2)\}]}$$

where f is the resonant frequency of each circuit.

If $R_1 = R_2$ the peak separation becomes

$$f_p = f\sqrt{(k^2 - 1/Q^2)}$$

and the two peak frequencies are

$$f\{1 \pm \frac{1}{2}\sqrt{(k^2 - 1/Q^2)}\}.$$

The width of the resonance curve at the trough is $f_t = f_p \sqrt{2}$.

If the circuit resistances are negligibly small, the peak frequencies are approximately $f\sqrt{1 \pm k}$.

These frequencies also represent the frequencies of free oscillations in two coupled circuits, as in a spark transmitter.

EXAMPLES 8

1. An oscillatory circuit consists of a coil of inductance 3500 microhenries and resistance 12 ohms, and a condenser of capacitance 900 micromicrofarads and resistance 1 ohm. Coupled with the coil of this circuit, with a mutual inductance of 100 microhenries, is a second coil through which is passed a current of 1 ampere at such a frequency as to make the current in the oscillatory circuit a maximum. Find the value of the current in the oscillatory circuit. (*C & G., Final, 1926.*)

2. Two circuits, each consisting of an inductance of 0.005 henry and a condenser of 0.003 microfarad, are coupled together by a condenser of 0.1 microfarad which forms a branch common to the two circuits. What is the coefficient of coupling? (*I.E.E., Oct., 1926.*)

3. The resonance curve of a spark transmitter is found to have two peaks, one at 590 metres and the other at 620 metres. Calculate the coefficient of coupling between the primary and secondary circuits. (*I.E.E., Oct., 1926.*)

4. Two tuned oscillatory circuits are coupled by mutual

inductance. Show that with sufficient coupling two current maxima will appear in the secondary, as the frequency of the e.m.f. in the primary is varied, and find an expression for the frequencies at which the maxima occur.

(*C. & G., Final, 1927.*)

5. Define mutual inductance. If an e.m.f. of 1 volt is induced in one coil by an alternating current of 5 milliamperes, frequency 500 000, in another coil, what is the mutual inductance between the two coils?

(*I.E.E., Oct., 1927.*)

6. Two circuits have a mutual inductance of 100 microhenries. What voltage will be induced in one circuit by a current in the other of 10 milliamperes (r.m.s.) at a frequency of 100 000 cycles?

(*C. & G., 1, 1928.*)

7. Two tuned circuits, each consisting of a condenser of 0.001 microfarad and an inductance of 1 500 microhenries, are coupled together by means of a third inductance of 200 microhenries common to both circuits. If free oscillations are set up in the circuits by some means, at what frequencies would they occur?

(*C. & G., Final, 1929.*)

8. Two circuits tuned to a frequency of 318 000 and each having a decay factor of 10 000 and an inductance of 400 μH . are coupled together by a mutual inductance of 10 μH . An e.m.f. of 1 volt is induced in the first circuit. Draw a curve showing the current in the second circuit as the frequency of the e.m.f. is varied from 2 per cent below to 2 per cent above the resonant frequency of the circuits.

(*L.U., 1931.*)

9. Two coils have inductances of 250 μH . and 100 μH . respectively. They are placed so that their mutual inductance is 50 μH . What will be their joint inductance (a) in series aiding, (b) in series opposing, (c) in parallel aiding, (d) in parallel opposing?

(*C. & G., Final, 1931.*)

10. A high frequency ammeter is coupled to an oscillatory circuit by means of an air cored transformer. The primary winding carries 100 amperes at 10^5 cycles per sec. The secondary circuit has a total inductance of 20 μH . and a mutual inductance with the primary of 1 μH . If the resistance of the secondary circuit including the meter is 4 ohms, what current will flow through the meter?

(*C. & G., Final, 1931.*)

11. A circuit of inductance L_2 and resistance R_2 is coupled by mutual inductance M to a coil of inductance L_1 and resistance R_1 . Derive an expression for the apparent input impedance of this coil.

(*I.E.E., May, 1931.*)

12. Two tuned circuits are coupled together magnetically

The inductance, resistance, and capacitance of the two circuits are in order—

1st circuit: 500 $\mu\text{H.}$, 25 ohms, 800 $\mu\mu\text{F.}$

2nd circuit: 800 $\mu\text{H.}$, 40 ohms, 500 $\mu\mu\text{F.}$

The mutual inductance is 90 $\mu\text{H.}$ An e.m.f. of 1 volt of varying frequency is induced in the first circuit. Draw a curve showing the current amplitude in the second as the frequency is varied through resonance. (L.U., 1932.)

13. Two circuits, each consisting of an inductance of 160 microhenries, a resistance of 10 ohms, and a condenser of 0.001 microfarad, are coupled by a mutual inductance between the inductances of 2 microhenries. If an e.m.f. of 100 volts r.m.s. at 400 000 cycles per sec. is applied in series with one circuit, what will be the currents in the circuits?

(C. & G., Final, 1932.)

14. Two coils, one of 800 $\mu\text{H.}$ and 200 ohms and the other of 200 $\mu\text{H.}$ and 40 ohms, are coupled by a mutual inductance of 150 $\mu\text{H.}$ A p.d. of 10 volts, frequency 79 600 cycles per sec., is established across the first. Find the current in the second when a condenser of 1 000 $\mu\mu\text{F.}$ is connected across its terminals.

(I.E.E., May, 1934.)

15. The effective resistance of a coil at an ω value of 10^6 is increased by 9.6 ohms when the coil is coupled by mutual inductance with a resonant circuit having a resistance of 15 ohms. Find the value of the mutual inductance, proving any formula used.

(I.E.E., Nov., 1934.)

16. Two circuits each consisting of an inductance of 1 mH., a resistance of 100 ohms, and a condenser of 0.001 $\mu\text{F.}$, are coupled by a mutual inductance between the coils of 10 $\mu\text{H.}$ At what frequency will an e.m.f. of 1 volt in one of the circuits produce maximum current in the other? What will be the value of the currents in each circuit?

(C. & G., Inter., 1935.)

17. Define mutual inductance. A glass tube, 3 cm. in diameter, is formed into a ring of 20 cm. diameter, and is wound uniformly with 1 200 turns of wire. A second coil of 500 turns is wound closely on the first. Find the mutual inductance between the two coils, in microhenries.

(I.E.E., Nov., 1935.)

18. A long solenoid of cross-sectional area 16 sq. cm. has a winding of 10 turns per cm. length. At the middle of the

solenoid is a secondary coil of 250 turns. What current, at a frequency of 1 000 cycles per second, must flow in the solenoid in order that a p.d. of 0.5 volt may appear at the secondary terminals?
(*I.E.E.*, May, 1936.)

19. Two circuits, each consisting of an inductance of 2 millihenries, a resistance of 200 ohms, and a condenser of 0.002 microfarads, are coupled by a mutual inductance of 10 microhenries. At what frequency will an e.m.f. of 1 volt in one of the circuits produce maximum current in the other? What will be the values of the current in each circuit?

(*I.E.E.*, Nov., 1936.)

20. Why are coupled circuits used in radio receivers? What is the advantage of variable coupling in a receiver? Indicate with diagrams two methods of providing variable coupling in a receiver. What is meant by the term "coefficient of coupling"?

(*C. & G.*, Prelim., 1937.)

21. A circuit consisting of a condenser of 0.001 microfarad capacitance and an inductance of 500 microhenries is coupled magnetically with a second consisting of a condenser of 0.0005 microfarad capacitance and an inductance of 1000 microhenries. The mutual inductance between the coils is 100 microhenries and the resistances of the primary and secondary coils are 15 ohms and 35 ohms respectively. What is the effective series impedance of the primary circuit at a frequency of 200 kc. per second?

(*C. & G.*, Inter., 1937.)

22. Two coils, each having an inductance of 200 μ H. and a resistance of 15 ohms, are tuned to a frequency of 400 kc/s. They are coupled by a mutual inductance of 8 μ H. to form a band-pass filter. Calculate (a) the value of the critical coupling; (b) the frequency separation of the secondary current peaks; (c) the width of the secondary current curve at the trough.

23. Two inductively-coupled circuits comprise resistance, capacitance, and inductance in series, in both the primary and the secondary circuits. Deduce a formula for the effective resistance and the effective impedance of the primary. If the values of resistance, capacitance, and inductance in the primary and secondary circuits, respectively, are 20 ohms, 0.005 μ F., 300 μ H.; 10 ohms, 0.001 μ F., 100 μ H., the mutual inductance is 20 μ H. and the frequency is 1 Mc/s, find the effective impedance as measured across the primary terminals.

(*C. & G.*, 3, 1938.)

24. Two circuits, each having a resistance of 20 ohms, an inductance of 500 μ H. and a capacitance of 1 000 μ μ F., are coupled together magnetically, the mutual inductance

being $20 \mu\text{H}$. An e.m.f. of 10 volts of varying frequency is injected from an external source into one circuit. Find the current in the second circuit when the frequency is above the natural frequency of each circuit and is adjusted to give the maximum current response in the second circuit.

(L.U., 1939.)

25. Each of two circuits *A* and *B* consists of a coil and a variable condenser. Each coil has an inductance of $1500 \mu\text{H}$. and a resistance of 30 ohms, and the two circuits have a mutual inductance of $100 \mu\text{H}$. Circuit *A* is tuned to $750/2\pi$ kc/s with *B* on open circuit, and circuit *B* is tuned to $810/2\pi$ kc/s with *A* on open circuit. Calculate the current in *B* when an e.m.f. of 2 volts, having a frequency of $780/2\pi$ kc/s, is induced in circuit *A*.

(L.U., 1940.)

9. DAMPED OSCILLATIONS

REFERENCES. *Admiralty Handbook of Wireless Telegraphy; Telegraphy and Telephony*, by Mallett.

The number of oscillations occurring in an oscillatory circuit before the amplitude is reduced to 1 per cent of the initial value is given by

$$N = 1 + 4.605/\delta$$

where δ is the decrement of the circuit.

$$\delta = R/2fL = \pi R/\omega L = \pi R\omega C = \pi R\sqrt{C/L}$$

The natural frequency of the circuit is given by

$$\omega^2 = (1/LC) - (R^2/4L^2)$$

A circuit in which *R* is equal to or greater than $2\sqrt{L/C}$ is aperiodic or non-oscillatory.

EXAMPLES 9

1. When does shock excitation occur in practice, and what are the results in a single circuit having inductance, capacity, and resistance in series? Find the number of free oscillations which occur in such a circuit before the amplitude is reduced to 1 per cent of its initial value. (L.U., 1925.)

2. A direct current is flowing in an inductance across which

a condenser is connected. Explain what happens when the source of supply of the current is suddenly disconnected.

(*C. & G.*, 1, 1926.)

3. A resonance circuit has the following constants: capacitance 0.003 microfarad, inductance 0.001 henry and resistance 10 ohms. The condenser is charged and allowed to discharge through the circuit. Calculate the number of oscillations which occur up to the point when the amplitude is reduced to 10 per cent of the initial amplitude. (*I.E.E.*, Oct., 1926.)

4. What is meant by logarithmic decrement? What is the expression for the logarithmic decrement of a simple resonant circuit consisting of inductance L , capacitance C , and resistance R ? If such a circuit has a logarithmic decrement of 0.115, how many cycles would occur after the circuit was initially excited before the amplitude of oscillations was reduced to 1 per cent of the initial value?

(*C. & G.*, Final, 1930.)

5. A condenser of 0.01 microfarad is charged to a d.c. potential and connected across an inductance of 1 000 microhenries having a resistance of 15 ohms. What time will elapse after connection before the amplitude of the oscillatory current has decreased to 1 per cent of its initial amplitude?

(*C. & G.*, Final, 1932.)

6. A condenser of 0.005 microfarad is charged and connected across an inductance of 2 millihenries having a resistance of 10 ohms. How many complete oscillations will occur before the amplitude of the oscillating current has decreased to 1 per cent of its initial amplitude? (*I.E.E.*, May, 1933.)

7. A condenser of capacity 350 micromicrofarads is charged and then connected across a coil of inductance 10^{-4} henries and resistance 2.5 ohms. Determine (i) the logarithmic decrement of the oscillation in the circuit, (ii) the time taken for the oscillation to fall to 1 per cent of its initial value and the number of oscillations during that time, (iii) the resistance which when connected in series with the circuit is just sufficient to damp out the oscillation. Assume that the radiation resistance of the circuit is negligible. (*L.U.*, 1934.)

8. What is meant by a damped oscillation? How are such oscillations produced? Why is the use of damped oscillations for radio-communication purposes declining?

(*C. & G.*, Prelim., 1936.)

9. A circuit consists of resistance, capacitance, and inductance in series. Either

(a) Write down the formula for the natural frequency of the circuit. If the resistance were negligible, the resonant

frequency would be $1/2\pi$ kc/s: If the inductance is 10 mH., what is the value of the resistance when the circuit is about to pass from a non-oscillatory to an oscillatory condition? or

(b) Deduce the formula for the natural frequency of the circuit. (C. & G., 3, 1940.)

10. SPARK TRANSMITTERS

The power input to the transmitter is given by

$$P = \frac{NCV^2}{2 \times 10^9} \text{ kilowatts}$$

where N = spark train frequency,

C = capacitance of primary condenser in microfarads,

V = charging voltage.

EXAMPLES 10

1. Describe the synchronous spark system and explain why it is desirable to tune the low frequency portion of the circuit.

(I.E.E., Oct., 1928.)

2. Explain the action in the oscillatory circuit of a spark transmitter. Show how to find the energy stored in the condensers, and hence the average power consumption in the circuit.

(C. & G., 1, 1927.)

3. Describe and explain the action of a synchronous spark system of wireless telegraph transmission.

(I.E.E., Oct., 1927.)

4. Draw a circuit diagram of a rotary spark transmitter of about $1\frac{1}{2}$ kW. input, assuming that a d.c. supply is available. Indicate the usual switches, fuses, and transmitting key.

(C. & G., 1, 1928.)

5. A spark transmitter has a transformer whose secondary winding is centre tapped. It is desired to modify this transmitter to a tonic train or interrupted continuous wave valve transmitter having the same note frequency as the original spark. Draw a diagram showing the essential components and circuits necessary to effect this.

(C. & G., 1; 1929.)

6. Describe, with sketches, three types of spark gap used on spark transmitters and state the advantages and disadvantages of each type.

(C. & G., 1, 1930.)

7. Describe the construction and action of a quenched spark gap. Give a description and wiring diagram of a $\frac{1}{4}$ kW. quenched spark transmitter suitable for marine use, to work from a 24-volt battery. (C. & G., 1, 1931.)

8. Give a diagram and description of a spark transmitter of about $1\frac{1}{2}$ kW. input. What determines the power input to a spark transmitter? Show how it is possible to change the wavelength of such a transmitter without changing the power input. (C. & G., 1, 1932.)

9. In a spark transmitter the primary condenser has a capacitance of 0.016 microfarad and is charged from an alternator through a transformer having a step-up ratio of 100. If the inductance of the alternator is 0.05 henry and the frequency of the alternator is 50 cycles per sec., what additional inductance should be added to the low-tension circuit to produce resonance? (C. & G., 1, 1933.)

10. In a spark transmitter, what is the effect on the emitted waves of increasing the coupling between the primary circuit and the aerial? What is the difference in this respect between a quenched spark and an unquenched spark transmitter? (C. & G., 1, 1933.)

11. A synchronous spark transmitter has a primary condenser of 0.1 microfarad capacitance and is charged from a transformer delivering 10 000 volts r.m.s. at 500 cycles per sec. If the charging circuit is tuned to resonance and one spark occurs every half cycle, what is the input power of the transmitter? (I.E.E., May, 1933.)

12. The primary circuit of a spark transmitter consists of an inductance of $1 \mu\text{H.}$ and a condenser of $0.025 \mu\text{F.}$ If the condenser is charged to 20 000 V. peak value when the spark occurs, what will be the maximum instantaneous value of current which flows through the inductance, neglecting any losses in the circuit? What will be the frequency of the oscillation? (C. & G., Prelim., 1934.)

13. Describe with a diagram the construction and working of a $\frac{1}{4}$ kW. spark transmitter suitable for marine use. What are the advantages of spark sets over I.C.W. sets for marine emergency purposes? (C. & G., Prelim., 1934.)

14. In a spark transmitter the closed circuit condenser has a capacitance of 0.16 microfarad. The high tension power transformer has a step-up ratio of 1 to 30. What inductance will be required in the primary circuit for low frequency tuning, if the frequency of the supply is 200 cycles per second? (C. & G., Prelim., 1937.)

11. HIGH FREQUENCY ALTERNATORS

EXAMPLES 11

1. Describe the construction of one type of high frequency alternator, and state the advantages and disadvantages of this as compared with a valve transmitter.

(*C. & G., Final, 1928.*)

2. Describe, with sketches, the construction and principle of operation of an alternator suitable for the generation of currents of 500 periods per sec. What factors determine the frequency generated by such a machine? (*C. & G., 1, 1931.*)

3. Describe with sketches any type of radio frequency alternator in use at the present time. How is the frequency maintained constant? What is the degree of constancy attained in practice? What are the approximate upper limits of frequency of such machines and what imposes this limit? What are the advantages and disadvantages of alternators as compared with valve transmitters?

(*C. & G., Final, 1931.*)

4. Describe with sketches (*a*) a rotating armature type alternator, (*b*) an inductor type alternator, suitable for a frequency of 500 cycles per sec. If the shaft of the machine rotates at 3 000 r.p.m., how many poles are necessary in each machine?

(*C. & G., Prelim., 1934.*)

5. Describe, with a diagram, the construction of one type of high frequency alternator used for radio transmission. What methods of keying are adopted with such machines?

(*C. & G., Inter., 1935.*)

12. RECTIFICATION

REFERENCES. *Wireless*, by Turner; *Radio Frequency Measurements*, by Moullin; *Telegraphy and Telephony*, by Mallett.

If a rectifier has a characteristic of the form $i = f(v)$ and if E is the r.m.s. value of the applied p.d., then the rectified current is given to a first approximation by

$$I = \frac{E^2}{2} \cdot \frac{d^2i}{dv^2}$$

EXAMPLES 12

1. Two oscillating e.m.f.'s, $a \sin pt$ and $b \sin qt$, are applied to the grid of a rectifier valve with a curved characteristic. Deduce an expression for the rectified output.

(*I.E.E.*, Oct., 1926.)

2. What is meant by rectification? Give instances of its use in transmitting circuits and in receiving circuits.

(*C. & G.*, 1, 1927.)

3. The relation between the current I through any rectifying device and the p.d. V between its terminals is given by the equation

$$I = aV + bV^2$$

Show that if an alternating voltage of any wave form and r.m.s. value E is applied to the rectifier, then a steady current J will flow of value $J = bE^2$.

(*I.E.E.*, Nov., 1929.)

4. What is the action of a crystal detector when used on a receiving set? Draw a typical characteristic curve of a crystal. Why is a polarizing potential sometimes necessary with a crystal detector? Give a diagram showing how such a potential is applied.

(*C. & G.*, 1, 1930.)

5. The relation between grid current and grid potential of a certain valve may be represented by a cubic equation. Derive a formula for the rectified current which would be produced by the application of a small alternating voltage between grid and filament.

(*I.E.E.*, May, 1930.)

6. A rectifier with a parabolic characteristic has applied to it a high frequency p.d. which is modulated simultaneously with two frequencies f_1 and f_2 . Show that the rectified current contains terms of frequency f_1 , f_2 , $2f_1$, $2f_2$, $(f_1 + f_2)$, and $(f_1 - f_2)$. Show also that the relative strength of these spurious tones depends on the depth of modulation.

(*I.E.E.*, May, 1931.)

7. What are meant by damped waves, continuous waves, and interrupted continuous waves? Why is a detector necessary in order to obtain audible indication in a telephone of high frequency oscillations? Is a simple detector sufficient in order to obtain audible indications of continuous waves? If not, state what additional apparatus is necessary and the reasons for its use.

(*C. & G.*, 1, 1932.)

8. Explain the action of a crystal detector. Why is high frequency amplification, before detection, of particular advantage in the reception of weak signals?

(*C. & G.*, Prelim., 1936.)

13. VALVES AND THEIR CHARACTERISTICS

Valve Constants

Fig. 6 represents portions of the mutual characteristics of a three-electrode valve for two anode voltages V and v .

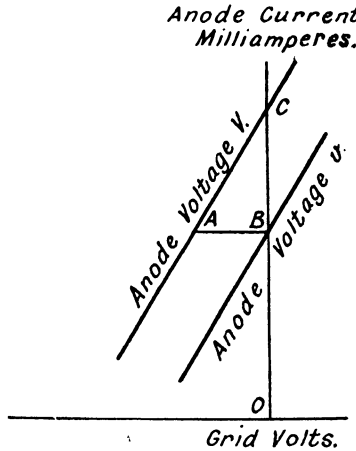

FIG. 6

The anode a.c. resistance $\rho = (V - v)/BC$ kilohms

The mutual conductance $g = BC/AB$ mA. per volt

The amplification factor $\mu = (V - v)/AB$

It follows that $\mu = g\rho$

Deriving a Mutual Characteristic from an Anode Characteristic

Let OA , Fig. 7, represent the anode current–anode voltage characteristic for a fixed grid voltage v . The same curve may be made to represent the anode current–grid voltage curve for a fixed anode voltage V if the amplification factor μ is known and is assumed to be constant.

Let the value V on the anode voltage scale be marked v to form one point on a new scale of grid voltage. The remainder of the latter scale may be completed by letting one unit along the axis represent $1/\mu$ of that represented

on the anode voltage scale, numbers on the right being made more positive and those to the left more negative.

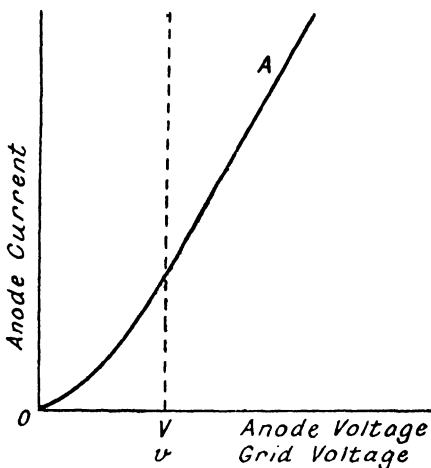

FIG. 7

If the curve OA had been drawn originally for zero grid volts, then a vertical erected at V , as shown dotted, would represent the zero ordinate on the required mutual characteristic.

Voltage Amplification

The voltage amplification given across a non-inductive resistance R in the anode circuit of a valve is

$$\mu[R/(R + \rho)]$$

EXAMPLES 13

1. Explain the difference between the static and dynamic characteristics of a triode valve in the case of (a) a resistance load in the anode circuit, and (b) a reactive load.

(*I.E.E.*, Oct., 1926.)

2. Explain carefully how the characteristic curves of a three-electrode thermionic valve can be obtained experimentally, and show how to derive from the curves the constants used in calculating the behaviour of the valve in various circuits.

(*L.U.*, 1926.)

3. Draw, giving approximate scales, a family of characteristic curves of a small three-electrode valve. Show how, from the curves, to find the values of two constants of the valve which will enable an estimate of its amplifying properties to be made. Derive an expression for the voltage amplification given across a non-inductive resistance in the anode circuit.

(*C. & G.*, *Final*, 1927.)

4. Draw typical characteristic curves for a three-electrode valve as follows—

(a) Grid voltage, anode current curves with constant filament current and various anode potentials.

(b) Grid voltage, grid current curve with constant filament current and constant anode potential.

(c) Grid voltage, anode current curves with different filament currents but constant anode potential.

(*C. & G.*, 1, 1930.)

5. Describe the action of a three-electrode thermionic valve. How is it used (a) as an amplifier, (b) as a detector? What is meant by amplification factor, a.c. impedance, and mutual conductance?

(*C. & G.*, 1, 1931.)

6. Explain why the anode current of a thermionic valve may be limited by the filament current and also by the presence of a space charge. How would you measure the amplification factor of a small receiving valve and of a high-power high-voltage transmitting valve?

(*I.E.E.*, *May*, 1931.)

7. Describe, with sketches, the construction and mounting of a copper anode power valve for use in a transmitting station.

(*I.E.E.*, *Nov.*, 1931.)

8. The relation between anode current and anode potential of a triode valve, in which the grid potential was zero, is given in the following table—

Anode potential, in V.	50	100	150	200	250	300	350
Anode current, in mA.	1.0	3.5	6.5	9.3	10.1	10.2	10.2

The amplification factor of the valve was 7.0. Derive the characteristic relating anode current and grid potential for a constant anode potential of 150 V.

(*I.E.E.*, *Nov.*, 1931, and *Nov.*, 1932.)

9. The following readings were taken on a three-electrode valve. Plot the characteristic grid voltage anode current

curves and determine the internal impedance at zero grid voltage, the amplification factor, and mutual conductance.

Grid voltage	0	- 2	- 4	- 6	- 8	- 12	- 14	- 16	- 18
Anode current in mA.									
(A) with 130 V. H.T.	15	13	11	9	7	3	1.5	0.7	0.2
(B) with 100 V. H.T.	10	8	6	4	2	0.4	0.1	—	—

(C. & G., 1, 1932.)

10. Describe the purpose and advantages of a screen-grid valve and of a pentode. Describe the physical principles of the action of the first, and sketch a common arrangement for the electrodes.

(I.E.E., May, 1932.)

11. What materials are used for the cathodes of small thermionic valves? Describe the formation of a space charge and explain why this modifies the distribution of electric field between the electrodes. Explain what is meant by secondary emission from an anode, and show how this may be produced.

(I.E.E., May, 1932.)

12. In a certain triode it was found that a current of 5 mA. was obtained when the anode and grid potentials had the following values—

V_a	500	310	139	86	58	35	10
V_g	- 32	- 12.5	3.5	9.5	13.5	16.5	26

Plot the curve relating V_a and V_g for this anode current, and deduce the amplification factor of the valve. Discuss why this factor becomes smaller when the grid is very positive.

(I.E.E., May, 1932.)

13. Describe, with a diagram, the method that you would adopt and the apparatus that you would use to determine the grid voltage anode current characteristic curves of a three-electrode valve.

(C. & G., 1, 1933.)

14. Describe with characteristic curves the action of a screen grid valve when used as a high frequency amplifier. What advantages, if any, does this valve possess over a three-electrode valve?

(I.E.E., May, 1933.)

15. What is a pentode? Describe the action of a pentode and the functions of the various electrodes when used as an audio frequency amplifier.

(I.E.E., May, 1933.)

16. What factors determine the electron emission from the filament of a thermionic valve? What materials are normally used for the filaments of present-day valves?

(I.E.E., Nov., 1933.)

17. Draw typical examples of the following characteristic curves—

(a) The anode voltage anode current curves of a diode for different filament currents.

(b) The anode current grid voltage curves of a triode for different values of anode voltage. (*C. & G., Prelim., 1934.*)

18. What is a pentode? Explain the functions performed by the various electrodes. Give a typical anode current grid voltage characteristic for a pentode.

(*C. & G., Inter., 1934.*)

19. Draw in section a cooled anode three-electrode transmitting valve and explain how the connection between the metal anode and the glass portion is effected. What materials are used for the anodes of such valves and what fluids are used for cooling?

(*C. & G., Inter., 1934.*)

20. Write a short account of the use of various forms of diode in modern wireless circuits.

(*I.E.E., Nov., 1934.*)

21. The following values of anode current were obtained with a triode—

Anode voltage . . .	25	50	75	100	Volts
Anode current with grid voltage = 0 . . .	0.4	2.8	6	8.5	mA.
Anode current with grid voltage = -4.2 . . .	0	0.6	3.0	5.7	mA.
Anode current with grid voltage = -8.3 . . .	0	0	1.0	2.9	mA.

Plot the anode current-anode voltage characteristic curves. If a battery of 150 volts and a resistance of 15 000 ohms are connected in series with the anode and cathode, what will be the anode current at the above three values of grid voltage?

(*C. & G., Prelim., 1935.*)

22. What is a screened grid valve? Describe the functions of the various electrodes. Draw a typical anode current-anode voltage characteristic curve for a screened grid valve and comment on the shape. What is a variable "mu" valve and how does it differ in construction and performance from the normal type?

(*C. & G., Inter., 1935.*)

23. The mains supply to two valves is at 400 volts. Between the mains and the anode of the first valve is a resistance of 10 000 ohms, and between the anode of the first valve and the anode of the second valve is a resistance of 5 000 ohms. The first valve takes a current of 12mA. and the second a current of 10 mA. Find the effective resistance of each valve.

(*I.E.E., May, 1935.*)

24. Write an account of the development and uses of multi-electrode valves.

(*I.E.E., May, 1935.*)

25. A three-electrode valve has the following static characteristics—

Grid voltage . . .	+ 2.5	0	- 2.5	- 5	- 7.5	- 10
Anode current in mA., with 120 volts h.t. . .	7	6.35	5.4	4.45	3.5	2.55
Anode current in mA., with 80 volts h.t. . .	4.75	3.8	2.85	1.9	1	0.5

Plot the characteristic grid voltage-anode current curves, and determine the internal impedance at zero grid voltage, the amplification factor and the mutual conductance.

(*C. & G., Prelim., 1936.*)

26. A triode valve has a characteristic given by $I_p = 0.002(E_p + 10E_g)^2$, where I_p is in mA. and E_p and E_g are in volts. Plot the characteristic curves for an anode voltage of 160, between values of E_g of + 4 and - 16. What is the mutual conductance of the valve at zero grid potential with the above anode voltage?

(*C. & G., Prelim., 1937.*)

27. A high- μ triode valve has the following characteristics (see table, page 41). Plot the characteristics, with the anode voltages as abscissæ and the anode currents as ordinates for the given values of grid potentials. If an external resistance is inserted in the anode circuit, what will be the anode currents with an anode voltage of 250 volts and grid voltages of - 2.0, - 1.5, - 1.0, - 0.5 and 0 when the external resistance is (a) 100 000 ohms, (b) 500 000 ohms?

(*C. & G., Inter., 1937.*)

Anode Voltage	Anode Current in mA. at Following Grid Potentials						
	- 3.0	- 2.5	- 2.0	- 1.5	- 1.0	- 0.5	0
60	0	0	0	0	0.08	0.4	0.9
80	0	0	0	0.01	0.19	0.59	1.16
100	0	0	0	0.06	0.30	0.79	1.45
120	0	0	0	0.12	0.49	1.02	1.76
140	0	0	0.03	0.24	0.68	1.28	—
160	0	0	0.10	0.40	0.92	1.52	—
180	0	0.03	0.18	0.58	1.16	—	—
200	0	0.08	0.30	0.80	1.41	—	—
220	0.02	0.14	0.48	1.03	—	—	—
240	0.05	0.24	0.68	1.30	—	—	—

28. What is the meaning and significance of the mutual conductance of a three-electrode thermionic valve? If the valve has an amplification factor of 30 and an impedance of 20 000 ohms, what is its mutual conductance?

(*C. & G.*, 1, 1940.)

29. The anode resistance of a triode is 1 000 ohms and its amplification factor is 6; a resistance of 1 200 ohms is connected in its anode circuit. Determine the value of the a.c. voltage to be applied in the grid circuit in order to ensure an a.c. power supply of 3 watts to the load resistance.

(*I.E.E.*, Nov., 1940.)

14. THE VALVE AS RECTIFIER

REFERENCES. *Wireless*, by Turner; *Radio Engineering*, by Terman; *Modern Radio Communication*, by Reyner (Pitman); *Thermionic Valves in Modern Radio Receivers*, by Witts (Pitman).

Grid Rectification

The output voltage across the anode resistance R is

$$\frac{E^2}{2} \cdot \frac{d^2i}{d^2e^2} \cdot \frac{R_g}{1 + R_g(di/de)} \cdot \frac{\mu R}{R + \rho}$$

where E is the r.m.s. signal voltage, e and i the instantaneous grid voltage and grid current respectively, R_g the grid leak, μ the amplification factor, and ρ the anode a.c. resistance.

If r is the effective resistance of the valve and leak in parallel and C the capacitance of the grid condenser, then the p.d. V applied to the grid is

$$E \cdot \frac{r}{\sqrt{[r^2 + 1/\omega^2 C^2]}}$$

Anode Rectification

The output voltage across the anode resistance R , if the signal voltage E is applied in the grid circuit is

$$\frac{E^2}{2} \cdot \frac{d^2 i}{de_g^2} \cdot \frac{R}{1 + R(di/de_g)}$$

where i is the instantaneous anode current and e_g and e_a the instantaneous grid and anode voltages respectively.

If the signal voltage E is applied in the anode circuit, the output signal becomes

$$\frac{\mu^2 E^2}{2} \cdot \frac{d^2 i}{de_a^2} \cdot \frac{R}{1 + R(di/de_a)}$$

The rectified current, ignoring the anode resistance, is

$$I = \frac{E^2}{2} \cdot \frac{d^2 i}{de_g^2}$$

If the mutual characteristic is a parabola,

$$i = a(b + e_g)^2$$

and

$$I = (E^2/2) \cdot 2a = aE^2$$

EXAMPLES 14

1. Draw diagrams showing two arrangements for using a three-electrode thermionic valve as a detector for wireless signals. Explain the action of each. (*L.U.*, 1925.)

2. Describe the anode bend and grid leak methods of rectification, and discuss their relative merits with weak and strong signals as regards rectified current strength and selectivity.

(*C. & G.*, *Final*, 1926.)

3. Explain in detail the actions taking place when a three-electrode valve is used as a detector employing grid rectification.

(*I.E.E.*, *Oct.*, 1927.)

4. Explain the action of a thermionic three-electrode valve as a rectifier for receiving purposes. Give typical characteristic curves of grid and anode current for such a valve.

(*C. & G.*, 1, 1928.)

5. In a valve receiver it is observed that when signals are being received the anode current of the detector valve decreases. In another receiver the anode current of the detector valve increases when signals are received. Explain the reasons for this difference if neither detector uses a grid leak.

(*C. & G.*, 1, 1929.)

6. Explain how the signal current varies with the incoming voltage when the anode-bend rectifying valve has square law characteristics. In what manner does the relation obtained affect the design of a wireless receiving apparatus?

(*L.U.*, 1929.)

7. A small receiving valve is being used as a cumulative grid rectifier. Why will a small positive bias for the grid usually be required if the valve has a dull filament, and usually not be required if it has a bright filament? To what fundamental cause do you ascribe this difference?

(*I.E.E.*, Nov., 1929.)

8. A voltage at 100 kc. per sec. is applied to a cumulative grid rectifier in which the effective resistance of valve and leak in parallel is 0.1 megohm. Find what the capacitance of the condenser must be in order that the p.d. applied to the grid shall be 90 per cent of the applied voltage.

(*I.E.E.*, May, 1931.)

9. A valve rectifier which functions by curvature of the anode-current/grid-potential characteristic has in the anode circuit a resistance R which is shunted by a large capacitance. A small sinoidal voltage is applied between grid and filament. Derive an expression for the steady change of voltage across the resistance R . The relation between anode current and grid potential is parabolic.

(*I.E.E.*, May, 1931.)

10. The relation between anode current and grid potential of a certain valve, in which the anode was maintained at a potential of 80 V., is given in the following table—

V_g (V.).	10	8	6	4	2	0	-2	-4	-6	-8	-10	-12
i (mA.)	5.63	4.88	4.13	3.38	2.63	1.88	1.2	0.6	0.22	0.02	0	0

A sinoidal voltage of r.m.s. value 8.5 V. is applied between the grid and a point whose potential is 2 V. negative to the filament. Plot the curve of anode current during a whole cycle of applied

voltage, and calculate the mean rectified current by finding the areas of the positive and negative half-cycles of current.

(*I.E.E.*, Nov., 1931.)

11. Describe the two usual methods of using a three-electrode valve for the rectification of wireless signals, and discuss their relative advantages.

(*L.U.*, 1932.)

12. Explain the action of an anode-bend valve rectifier. If the static characteristic of the valve follows a square law, and the anode current is 8.0 mA. with zero grid volts and 2.0 mA. with -5 grid volts, what rectified current will be obtained with an alternating grid potential of 1.5 volts (r.m.s.)?

(*L.U.*, 1933.)

13. Describe three methods in which a thermionic valve can be used for detection. Explain the action of the valve in each case.

(*C. & G.*, *Prelim.*, 1934.)

14. Explain how a three-electrode valve having a square-law characteristic is used in the reception of wireless signals. If the anode current at a certain anode voltage is given in milliamperes by the expression $I_a = 0.1(6 + V_g)^2$, find the rectified current given by a signal which establishes across grid and filament a potential difference of 2 volts r.m.s.

(*I.E.E.*, Nov., 1934.)

15. Explain the use of diodes and three-electrode valves in rectification. Give reasons for the employment of a diode for rectification in modern broadcast receiving sets.

(*I.E.E.*, May, 1935.)

15. THE VALVE AS AMPLIFIER

REFERENCES. *Wireless*, by Turner; *Admiralty Handbook of Wireless Telegraphy*; *Telegraphy and Telephony*, by Mallett; *Radio Engineering*, by Terman; *Principles of Radio Engineering*, by Glasgow; *Thermionic Valves in Modern Radio Receivers*, by Witts.

Voltage Amplification

GENERAL. The voltage amplification factor m is given by

$$m = \mu[Z/(\rho + Z)]$$

where μ and ρ are the amplification factor and the a.c. resistance of the valve respectively, and Z is the impedance in the anode circuit expressed as a vector. This equation is a vector equation.

(a) *Resistance coupling.*

$$m = \mu \cdot [R/(\rho + R)]$$

If the resistance R is shunted by a capacitance C ,

$$m = \mu \frac{R}{\sqrt{[(\rho + R)^2 + \omega^2 C^2 \rho^2 R^2]}}$$

(b) *Choke coupling.*

$$m = \mu \frac{\omega L}{\sqrt{(\rho^2 + \omega^2 L^2)}}$$

If the choke has a resistance R ,

$$m = \mu \sqrt{\left[\frac{R^2 + \omega^2 L^2}{(R + \rho)^2 + \omega^2 L^2} \right]}$$

(c) *Tuned anode.* At resonance,

$$m = \mu \frac{L}{L + \rho CR}$$

$$= \frac{\mu}{1 + \rho CR/L}$$

At frequency ω , if $R \ll \omega L$,

$$m = \frac{\mu}{\sqrt{\{[1 + \rho CR/L]^2 + [(\rho/\omega_0 L) (\omega/\omega_0 - \omega_0/\omega)]^2\}}}$$

$$= \frac{\mu L}{\sqrt{\{[L + \rho CR]^2 + [\rho C(\omega L - 1/\omega C)]^2\}}}$$

$$= \frac{\mu L}{\sqrt{\{[L + \rho CR]^2 + [\rho(\omega/\omega_0^2 - 1/\omega)]^2\}}}$$

where ω_0 is the resonant pulsance.

(d) *Transformer coupling.* Assuming an ideal transformer with unity coupling factor and the secondary load a pure non-inductive resistance R ,

$$m = \mu [RT/(R + \rho T^2)]$$

where T is the step-up ratio of the transformer.

This has a maximum value $m = \mu T/2$ when

$$T = \sqrt{(R/\rho)}$$

If the secondary load is assumed to be infinite

$$m = \mu \frac{T\sqrt{(R^2 + \omega^2 L^2)}}{\sqrt{[(R + \rho)^2 + \omega^2 L^2]}}$$

where R and L are the resistance and inductance respectively of the primary.

In a radio frequency amplifier with infinite secondary impedance

$$m = \mu \frac{\omega k \sqrt{(L_1 L_2)}}{\sqrt{[\rho^2 + (\omega L_1)^2]}} = \mu \frac{\omega M}{\sqrt{[\rho^2 + (\omega L_1)^2]}}$$

where k is the coupling factor and L_1 and L_2 are the inductances of the primary and secondary respectively and M their mutual inductance.

Power Amplification

For maximum power output the load resistance R in the anode circuit is given by $R = \rho$, where ρ is the anode a.c. resistance of the valve.

If the load resistance R is coupled to the anode circuit by a transformer, then for maximum output

$$R = \rho/T^2$$

where T is the ratio of the primary to the secondary turns

or
$$T = \sqrt{(\rho/R)}$$

The turns ratio of an output transformer is given approximately by $T = \sqrt{(R_o/Z_s)}$

where Z_s = impedance of speech coil at 400 c/s

R_o = optimum load of the output valve.

For triodes, R_o usually lies between 2ρ and 3ρ .

For pentodes, R_o usually lies between $\rho/4$ and $\rho/10$.

With two output valves in parallel,

$$\text{optimum load} = R_o/2.$$

With two output valves in push-pull.

$$\text{optimum load} = 2R_o.$$

Negative Feed-back

If A = voltage amplification factor of amplifier,
 β = fraction of output voltage fed back in series
 opposition with input,

$$\begin{aligned} \text{Resultant amplification} &= A/(1 + \beta A) \\ &\doteq 1/\beta \text{ if } \beta A \gg 1. \end{aligned}$$

The Decibel

If one power P_1 exceeds another power P_2 by D decibels,
 then $D = 10 \log (P_1/P_2)$

Similarly, the relationship between two voltages or two
 currents may be expressed in decibels if these quantities
 operate in equal impedances. Thus,

$$\begin{aligned} D &= 20 \log (V_1/V_2) \\ D &= 20 \log (I_1/I_2). \end{aligned}$$

The Cathode Follower

If the valve has constants μ , ρ , g and the cathode resist-
 ance is R , the voltage amplification factor of the stage is

$$m = \mu / \{\mu + 1 + (\rho/R)\}$$

The output impedance

$$Z_o = \frac{m}{g}$$

The a.c. resistance to h.t. fluctuations is

$$R_a = \rho + R (\mu + 1)$$

EXAMPLES 15

1. A triode, employed as a cathode follower, has an ampli-
 fication factor of 40 and a mutual conductance of 4 mA. per
 volt; the cathode resistance is 10 kilohms. Calculate (a) the
 voltage amplification of the stage; (b) the output impedance;
 (c) the anode a.c. impedance of the stage to voltage fluctuations
 between anode and h.t. negative.

2. What is meant by the tuned anode method of high
 frequency amplification? If the coil has an inductance of
 400 microhenries and resistance 10 ohms, the condenser a
 capacitance of 500 micromicrofarads and resistance 1 ohm,

what at resonance will be the voltage available from a signal voltage of 0.1 between the grid and filament of the valve, if the latter has an amplification factor of 12 and an internal resistance of 30 000 ohms? (C. & G., *Final*, 1926.)

3. The slope of the anode-current grid-potential curve of a three-electrode valve is 1.05 milliamperes per volt, and the slope of the anode-current anode-potential curve is 0.40 milliampere per volt. What voltage amplification will the valve give across an anode resistance of 15 000 ohms? Prove any formula used. (I.E.E., *Oct.*, 1927.)

4. A valve amplifier consists of a valve having an internal anode circuit impedance of 30 000 ohms and an amplification factor of 25. An external impedance is placed in the anode circuit. What is the amplification obtainable with this arrangement if this impedance consists of—

(1) A resistance of 30 000 ohms.

(2) A coil of 5 millihenries and 25 ohms resistance shunted by a condenser of 0.001 microfarad, the amplifier in this case being operated at the resonant frequency of this circuit? (C. & G., *Final*, 1929.)

5. A valve having an amplification factor of 7 and an anode slope resistance of 7 000 ohms is to be used as a low frequency amplifier. The anode circuit transformer has a transformation ratio of 3, and its low resistance winding has an inductance of 10 henries. Calculate the magnification for voltages of frequency 100 and 400 cycles per sec. (I.E.E., *Nov.*, 1929.)

6. Explain how valves may be used to amplify high frequency voltages, paying particular attention to the various methods that are available for avoiding reaction.

(L.U., 1930.)

7. Explain and describe some neutralizing methods of producing stability in valve amplifiers. (I.E.E., *May*, 1930.)

8. A triode valve has an internal resistance of 20 000 ohms and an amplification factor of 14. A non-inductive resistance of 50,000 ohms is connected between anode and filament. Calculate the p.d. across this resistance when a p.d. of 1 volt is applied between grid and filament. Explain and justify all the steps of your calculation. (I.E.E., *May*, 1930.)

9. A gramophone pick-up gives 0.5 volt. Give an outline design of an amplifying circuit suitable for delivering 10 watts to a loud-speaker having an impedance of 1 000 ohms. Include details of the valves used. (L.U., 1931.)

10. In a two-stage amplifier the first valve has an amplification factor of 20 with a plate impedance of 25 000 ohms and a

tuned anode circuit, inductance of 4 000 μH . and resistance of 100 ohms, tuned by a variable condenser. The second valve has an amplification factor of 6, a plate impedance of 10 000 ohms, and an output impedance consisting of a choke of 10 000 μH . inductance. What will be the voltage amplification of the amplifier at a frequency of 100 kc.?

(*C. & G.*, *Final*, 1931.)

11. What are the causes of instability in radio frequency amplifiers? How are these troubles overcome in practice? Give a circuit diagram of the radio frequency circuits of a receiver having two radio frequency amplifier stages.

(*C. & G.*, *Final*, 1931.)

12. In any valve amplifier of very large magnification there is a background noise which originates within the apparatus. Describe some probable causes of the origin of this noise and any means of reducing it.

(*I.E.E.*, *May*, 1931.)

13. A valve has an anode slope resistance of 20 000 ohms and an amplification factor of 10. There is a non-inductive resistance of 100 000 ohms, shunted by a capacitance of 100 $\mu\mu\text{F}$. in the anode circuit. Calculate the magnification for voltages of frequency 100 kc. per sec.

(*I.E.E.*, *May*, 1931.)

14. A valve has an anode slope resistance of 30 000 ohms and an amplification factor of 16, and is to be used as a tuned-anode high frequency amplifier for a frequency of 100 kc. per sec. The coil in the anode circuit has an inductance of 2 mH. and a resistance of 10 ohms. Find the tuning capacitance with which this coil must be shunted and the magnification at 100 kc. per sec. If the circuit is left unaltered, what would be the magnification at 200 kc. per sec.?

(*I.E.E.*, *May*, 1931.)

15. Estimate the improvement in transmission to be obtained from a two-valve, two-wire repeater having the following constants—

Amplification factor of valve = 9.0

Internal resistance of valve = 22 000 ohms

Impedance of line = 85Q ohms

Step-up ratio of input transformer = 30

The transformers may be assumed to be ideal and properly designed.

(*L.U.*, 1932.)

16. Explain the action of the three-electrode valve when used as an amplifier. In a particular case, with a load resistance of 8 000 ohms the voltage amplification was 5.5 and with 12 000 ohms it was 6.5. What amplification at a frequency

of 800 cycles per sec. would be expected, using a choke coil of 10 H. inductance? (L.U., 1932.)

17. In an audio frequency amplifier the valve has an amplification factor of 40 and an internal impedance of 40 000 ohms. It is coupled to a succeeding stage by a transformer of 1 to 3.5 ratio having a primary inductance of 40 henries and a primary resistance of 500 ohms. The secondary load is of infinite impedance. What will be the amplification for frequencies of 40, 100, 1 000, and 10 000 cycles per sec. if the primary of the transformer resonates at 10 000 cycles?

(C. & G., Final, 1932.)

18. Describe the construction of an iron-cored transformer suitable for use in an audio frequency amplifier. The output valve in a receiver is coupled to a loud-speaker through a transformer. The impedance of the loud-speaker is 15 ohms, and it is desired that the primary winding of the transformer should present a load of 7 500 ohms to the valve. What should be the winding ratio of the transformer? (C. & G., 1, 1932.)

19. Discuss the advantage of a "push-pull" arrangement of valves in an amplifier, and draw a circuit diagram of a simple broadcasting receiver in which such an amplifier is used.

(I.E.E., May, 1932.)

20. The relation between anode current and grid potential for a certain triode in which the anode was fed through a non-inductive resistance of 100 000 ohms is given in the following table—

Grid potential, V.	-12	-10	-8	-6	-4	-2	0	2	4	6	8
Anode current, mA.	0.05	0.105	0.2	0.3	0.5	0.75	1.0	1.25	1.45	1.52	1.55

If the grid has a negative bias of 4 volts, find the amplification for an applied p.d. of 0.25 volt (r.m.s.), and plot the complete cycles of anode current which will result from an applied p.d. of 5.7 volts (r.m.s.). (I.E.E., May, 1932.)

21. A valve has an anode slope resistance of 20 000 ohms and an amplification factor of 16. It is used as a low frequency amplifier and the anode impedance is an inductance of 2 henries. Calculate the magnification when the input voltage has a frequency of 4 kilocycles per sec. (I.E.E., Nov., 1932.)

22. What factors determine the condition for maximum power output from a valve amplifier working at a given frequency? The tuned anode circuit of a three-electrode valve used as an amplifier consists of a coil having an inductance of 160 microhenries and a resistance of 8 ohms in parallel

with a condenser of capacity 0.001 microfarad. If the plate of the valve is connected to the electrical mid-point of the coil, determine the internal resistance of the valve for maximum power output. Assume that the anode current is small compared with the oscillatory current. (*L.U.*, 1933.)

23. Describe, with circuit diagrams, the principles of action of choke-coupled, transformer-coupled, and resistance-coupled audio frequency amplifiers. How do the characteristics of each type vary with frequency? (*C. & G.*, 1, 1933.)

24. The intermediate frequency amplifier of a superheterodyne receiver consists of three stages with tuned anode coupling adjusted to a mid-band frequency of 100 kilocycles per sec. Each valve has an amplification factor of 100 and an internal impedance of 100 000 ohms. The anode circuit inductance is 5 millihenries with a resistance of 30 ohms. What is the gain of the amplifier in decibels between the grid circuit of the first valve and the anode circuit of the third valve at a frequency (a) of 100 kilocycles per sec., and (b) of 90 kilocycles per sec.? (*I.E.E.*, *May*, 1933.)

25. Discuss the various methods used to ensure stability in high frequency amplifiers, (a) in receiving sets, and (b) in short-wave transmitters. (*I.E.E.*, *May*, 1933.)

26. A valve has an a.c. resistance of 25 000 ohms and an amplification factor of 20. In the anode circuit is connected a tuned circuit consisting of a coil of 10 millihenries inductance and 200 ohms resistance in parallel with a condenser of 0.001 microfarad. What will be the voltage amplification of the combination (a) at the resonant frequency of the anode circuit, and (b) at 0.9 of the resonant frequency? (*I.E.E.*, *Nov.*, 1933.)

27. Why is a high frequency amplifier consisting of a triode with tuned-grid and tuned-anode circuits liable to be unstable? How can such an amplifier be stabilized? (*I.E.E.*, *Nov.*, 1933.)

28. Explain the neutrodyne principle, and show how it can be applied to prevent a valve amplifier from generating local oscillations as a result of interelectrode capacity. Draw a diagram of connections for a push-pull neutrodyne amplifier. (*L.U.*, 1934.)

29. Explain precisely the meaning of the symbols in the expression

$$I_a = \frac{\mu V_g}{R_a + Z}$$

In connection with a valve amplifier, and establish the relationship, stating the assumptions made. (*I.E.E., Nov., 1934.*)

30. Describe the push-pull method of amplification, and enumerate and explain its advantages over the single valve method. (*I.E.E., May, 1935.*)

31. The voltage amplification given by a three-electrode valve is 3.65 when the load resistance is 15 000 ohms and 5.10 when the load resistance is 30 000 ohms. Find the amplification factor and internal resistance of the valve, proving any formula used. (*I.E.E., May, 1935.*)

32. Explain carefully what are meant by the amplification factor and the internal resistance of a valve. Show that an equivalent circuit of a valve may be formed consisting of an e.m.f. equal to the grid voltage multiplied by the amplification factor, in series with the internal resistance and the load impedance of the valve. State the conditions which must be fulfilled for this circuit to be used. (*I.E.E., Nov., 1935.*)

33. Describe the method of amplification known as quiescent push-pull, explaining its advantages and disadvantages.

(*I.E.E., Nov., 1935.*)

34. A three-electrode thermionic valve is to be used as a high-frequency amplifier, employing a tuned anode impedance consisting of a condenser and an inductance in parallel. Show how the voltage amplification obtainable at a given frequency depends upon the characteristics of the valve and of the external circuit. A certain three-electrode valve used as an amplifier has a mutual conductance of 1 mA. per volt and an a.c. resistance of 20 000 ohms. The external anode circuit impedance, which is tuned to a frequency of 1 megacycle per sec. consists of a coil with an inductance of 0.2 mH. and a resistance of 5 ohms, in parallel with a condenser having an insulation resistance of 1 megohm. If a sine wave alternating e.m.f. of 1.5 volts is impressed on the grid, calculate the magnitude of the alternating p.d. developed across the anode impedance. (*L.U., 1935.*)

35. Give a diagram of a low frequency transformer-coupled amplifier. What tends to limit the amplification of such an amplifier (a) at low frequencies, and (b) at high frequencies?

(*C. & G., Prelim., 1936.*)

36. Describe the action of the three-electrode valve amplifier. If the voltage amplification obtained with load resistances of 15 000 and 25 000 ohms is 6.5 and 8.0 respectively, what amplification will be obtained with a load resistance of 50 000 ohms? Assume linear characteristics. (*I.E.E., May, 1936.*)

37. Describe the action of the three-electrode valve amplifier.

A valve has an anode slope resistance of 20 000 ohms and an amplification factor of 16. It is used as a low frequency amplifier with an anode load of 2 henries inductance and negligible resistance. Calculate the magnification when the input voltage has a frequency of 4 kc. per sec.

(*I.E.E.*, Nov., 1936.)

38. Define (a) the decibel, (b) the neper. A low frequency amplifier has a gain of 56 decibels. The input circuit is of 600 ohms resistive impedance and the output is arranged for a load of 10 ohms. What will be the current in the load when an alternating potential of 1 volt is applied at the input? A transmission line has an equivalent of 7 decibels; what is the equivalent of this in nepers?

(*C. & G.*, *Inter.*, 1937.)

39. In an audio-frequency amplifier the valve has an internal impedance of 30 000 ohms and an amplification factor of 40. It is coupled to the succeeding stage by a transformer having a ratio of 1 to 3 and a primary inductance of 30 henries. The secondary load is a resistance of 500 000 ohms. Neglecting the internal capacitances of the valve and the self-capacitance, resistance, and leakage of the transformer, what will be the amplification for frequencies of 100 and 10 000 cycles per second?

(*C. & G.*, *Final*, 1937.)

40. Calculate the current and the voltage-drop in a 600-ohm resistance in which the power dissipated is (a) 5 decibels above, and (b) 10 decibels below, 1 mW. Compute the ratios of voltages and currents when equal powers are dissipated in 600-ohm and 1 200-ohm resistances.

(*I.E.E.*, Nov., 1937.)

41. A low frequency amplifier has a gain of 40 decibels. The impedance of the input circuit is 600 ohms (resistive) and the output is arranged for a load of 20 ohms. What will be the current in the load when an alternating potential of 1 volt is applied at the input?

(*I.E.E.*, Nov., 1938.)

42. Two valves, one with a voltage amplification factor of 40 and the other 20, have an anode a.c. resistance of 100 000 and 20 000 ohms respectively. Which valve will give the greater voltage amplification with a resistance of 50 000 ohms in its anode circuit?

(*I.E.E.*, May, 1938.)

43. A three-electrode valve obeys the following equation over its working range: $I_a = 0.12V_a + 0.90V_g - 3.1$ where I_a is the anode current in mA., and V_a and V_g are the anode and grid potentials, respectively, in volts. Calculate the amplification of potential when a resistance of 12 000 ohms is inserted in the anode circuit.

(*I.E.E.*, Nov., 1938.)

44. Give a circuit diagram of a two-stage radio-frequency voltage amplifier. If 90 per cent of the oscillatory voltage

developed across the anode circuit of the first valve is applied across the grid circuit of the second valve, calculate the effective voltage amplification of the first stage from the following data: Valve amplification factor = 30, a.c. resistance of valve = 10 000 ohms, effective output impedance = 45 000 ohms. (C. & G., 2, 1938.)

45. What is meant by the load line of a power valve? A triode has the following anode characteristics—

Grid Volts = 0		Grid Volts = - 40		Grid Volts = - 80	
Anode Volts	Anode Current	Anode Volts	Anode Current	Anode Volts	Anode Current
50	12	—	—	—	—
75	25	175	10	300	7
100	43	200	23	325	17
125	65	225	38	—	—
—	—	250	58	350	28

If the grid bias is - 40, the anode voltage supply 350 volts and the external load 6 000 ohms, calculate the power output when the grid swing has an amplitude of 40 volts.

(C. & G., 2, 1939.)

46. A triode valve gives a voltage amplification of 25 decibels at a frequency of 100 kc/s when the external anode-circuit impedance consists of a resistance of 50 000 ohms shunted by a capacitance of 100 $\mu\mu\text{F}$. If the valve employed has an anode a.c. resistance of 14 000 ohms, calculate its mutual conductance.

(I.E.E., Nov., 1939.)

47. A certain pentode has the following characteristics when operated at a screen voltage of 400 V.—

P.d. between control grid and cathode	Anode Current (mA.)			
	P.d. between anode and cathode (volts)			
	200	300	400	600
— 8 volts	100	110	115	120
— 16 „	51	59	63	67
— 24 „	19	21	22	23

Find the amplification factor, the anode impedance and the mutual conductance of the valve when the grid bias is -16 V. and the anode voltage is 400 V. If the peak value of a sinoidal voltage applied to the grid is 8 volts, calculate the power output and the second harmonic distortion when the load resistance is $4\ 000$ ohms. (L.U., 1939.)

48. A triode has an amplification factor of 25 and an internal resistance (a.c.) of $18\ 000$ ohms. In its anode circuit is a coil having an inductance of $250\ \mu\text{H.}$ and a resistance of 8 ohms tuned by a parallel condenser to a frequency of 500 kc/s. Calculate the voltage amplification at (a) 500 kc/s, (b) 450 kc/s. (L.U., 1939.)

49. Describe two methods of applying negative feed-back to an audio-frequency amplifier, and compare their advantages. (C. & G., 2, 1940.)

50. A single-valve amplifier having an input transformer with a turns ratio of 1 to 5 and an output transformer whose ratio is arranged to match impedances and obtain maximum power gain, is inserted in a long line of which the characteristic impedance is 600 ohms. If the amplification factor of the valve is 12 and its a.c. resistance is $8\ 000$ ohms, estimate the gain in decibels. (I.E.E., May, 1940.)

51. A loud speaker having an effective resistance of 30 ohms is to be connected to the secondary of a transformer, the primary of which is in the anode circuit of a triode having an anode a.c. resistance of 850 ohms. Determine from first principles the most efficient ratio of transformation, assuming that the speaker has (a) negligible reactance, (b) reactance of 25 ohms. Neglect the magnetizing current and the losses of the transformer. (L.U., 1940.)

✓52. What do you understand by a negative feed-back amplifier? For what purposes is this type of amplifier employed, and what are its advantages? If the overall gain of a feed-back amplifier is 60 db., and the attenuation in the feed-back path is 61 db. what gain has the amplifier without the feed-back? (I.E.E., Nov., 1940.)

53. In a low-frequency amplifier, the input voltage is applied across a 600 -ohm resistance in parallel with the grid and cathode of a triode: the latter has a voltage amplification factor of 20 and an internal a.c. resistance of $12\ 000$ ohms. In the anode circuit is a $15/1$ step-down output transformer feeding a resistive load of 60 ohms. Calculate the overall gain of the amplifier in decibels. (I.E.E., May, 1941.)

54. A triode of voltage amplification factor 30 and internal resistance $50\ 000$ ohms is to be used as a tuned-anode amplifier

for speech-modulated signals of carrier frequency 1 Mc/s. The coil in the anode circuit has an inductance of 200 μ H. and an effective resistance of 5 ohms. With what capacitance must this coil be shunted, and what is the voltage amplification at the carrier frequency and at 1.01 Mc/s? Hence discuss the effect of the amplifier on a speech-modulated signal.

(I.E.E., May, 1941.)

16. THE VALVE AS GENERATOR

REFERENCES. *Telegraphy and Telephony*, by Mallett; *Radio Frequency Measurements*, by Moullin; *Wireless*, by Turner; *Theory and Design of Valve Oscillators*, by Thomas.

Tuned Grid Circuit

Condition for oscillation is $M = RC/g$, where M is the mutual inductance between the anode and grid coils, R and C the resistance and capacitance of the tuned circuit, and g the mutual conductance of the valve.

The effective resistance is $R - gM/C$.

The pulsance $\omega = 1/\sqrt{LC}$, where L is the inductance of the tuned circuit.

Tuned Anode Circuit

Condition for oscillation is $gM = CR + aL$, where $a = 1/\rho$.

The effective resistance is $R - (1/C)(gM - aL)$.

The pulsance $\omega = \sqrt{(1 + aR)/LC} \doteq 1/\sqrt{LC}$.

The ratio $\frac{h\text{th harmonic current}}{\text{fundamental current}}$ is given by

$$\frac{I_h}{I_1} \cdot \frac{\delta}{\pi} \cdot \frac{1}{h^2 - 1} \text{ in the coil, and}$$

$$\frac{I_h}{I_1} \cdot \frac{\delta}{\pi} \cdot \frac{h^2}{h^2 - 1} \text{ in the condenser,}$$

where I_1 is the fundamental anode current and I_h its h th harmonic, and δ is the decrement of the LCR circuit.

Anode Tap

For maximum power, the fraction to be tapped from the filament end is

$$b = \sqrt{(CR\rho/L)}$$

The condition for oscillation is

$$M = 2bL/\mu$$

The optimum inductance is then $\sqrt{(R\rho)/\omega}$ and the optimum capacitance is $1/\omega \sqrt{(R\rho)}$.

Dynatron

Condition for oscillation is $r = L/CR$, where r is the negative slope resistance of the valve.

The effective resistance is $R - L/Cr$.

$$\text{The pulsance } \omega = \sqrt{\left[\frac{1 - R/r}{LC} \right]}.$$

Phase Shift Oscillator

Three-section type

$$\text{Minimum gain} = 29$$

$$\text{Pulsance } \omega = 1/CR\sqrt{6} \text{ (Phase advance)}$$

$$\omega = \sqrt{6}/CR \text{ (Phase retard)}$$

Four-section type

$$\text{Minimum gain} = 18.4$$

$$\omega = \sqrt{0.7}/CR \text{ (Phase advance)}$$

$$\omega = 1/CR\sqrt{0.7} \text{ (Phase retard)}$$

EXAMPLES 16

1. Draw a diagram of connections showing how a three-electrode thermionic valve may be used to generate high frequency currents, and explain the action. Upon what circumstances does the high frequency power that can be obtained depend? (C. & G., 1, 1926.)

2. Describe how by employing a valve with reaction the high frequency resistance of an oscillatory circuit may be reduced. Find an expression connecting the oscillatory current with the applied potential difference in terms of the mutual inductance of the reaction and the circuit and valve constants, and hence find the mutual inductance necessary for self-oscillations to commence. (C. & G., *Final*, 1926.)

3. Explain how high frequency alternating currents may be produced by means of a three-electrode valve. Discuss the conditions necessary to be fulfilled in the circuit arrangement described. (C. & G., *Final*, 1927.)

4. Explain how a three-electrode valve may be used to

produce high frequency alternating currents. Discuss the design of the circuit arrangements. (*I.E.E.*, Oct., 1927.)

5. Give sketches showing one arrangement for the maintenance of electrical oscillations by a triode valve, and discuss mathematically the necessary circuit conditions. (*L.U.*, 1929.)

6. A triode generator has an inductance, resistance, capacitance circuit in series with the anode, and this circuit is coupled to the grid by a mutual inductance. Derive the condition for the starting of self-oscillation. (*I.E.E.*, Nov., 1929.)

7. Explain briefly the use of the "anode tap," or similar adjustment in a valve generator. A triode has a filament emission of 2 A. The anode is fed from a supply at 20 kV., but can dissipate only 2 kW. steadily without overheating. Calculate approximately the greatest high-frequency output obtainable for brief periods; show that to deliver as much as half this output continuously, the generator must be arranged to have an efficiency of not less than 72 per cent, reckoned without regard to the power used in the filament.

(*I.E.E.*, Nov., 1929.)

8. Show that, if an oscillating valve circuit is arranged so that the maximum power output is obtained, the efficiency (neglecting the power used in heating the filament) is only 50 per cent. Explain how the efficiency may be increased, and state the attendant disadvantages. (*L.U.*, 1930.)

9. Describe, with schematic diagrams, three different circuits in which a three-electrode valve can be used to generate oscillations. (*C. & G.*, 1, 1930.)

10. Draw the circuit diagram of a small valve generator, suitable for laboratory measurements for generating current of frequency about 30 000 kc. per sec. State approximate electrical dimensions for the components and also describe their mechanical construction, giving approximate linear dimensions. (*I.E.E.*, May, 1930.)

11. Explain the action of a valve oscillator with a tuned-anode circuit. If the anode circuit has a resonant frequency of $500\,000/2\pi$ and a decay factor of 12 500, and if the frequency of the oscillations produced is 0.1 per cent less than the resonant frequency of the circuit, the valve employed having an internal resistance of 10 000 ohms and an amplification factor of 10, find the mutual inductance between the anode and the grid coils necessary for the maintenance of oscillation, on the assumption that capacitance effects are negligible.

(*L.U.*, 1931.)

12. What factors limit the power output and the high-frequency current obtainable from a valve generator? Why

is the current in the oscillatory circuit relatively free from higher harmonics? (*I.E.E., May, 1931.*)

13. The grid of a small receiving valve is maintained at a potential of about 200 V. positive to the filament, and a curve is plotted connecting anode current and anode potential. Sketch the form of curve which would be obtained, and explain the physical mechanism which produces the portion with a negative slope. Show, with circuit diagrams, how such an arrangement can be used to produce continuous oscillations in an oscillatory circuit (Dynatron generator). (*I.E.E., Nov., 1931.*)

14. Explain the purpose of an "anode tap" or similar adjustment in a valve generator and explain why it is often essential to operate the valve of a generator at an efficiency higher than that corresponding to maximum output.

(*I.E.E., Nov., 1931.*)

15. Find expressions for the condition for maintenance and for the frequency in a valve oscillator with the tuned circuit connected to the anode. Show all the voltages and currents involved in a vector diagram, and indicate how the frequency of the oscillation departs from the resonance frequency of the oscillatory circuit. Suggest a method of eliminating this departure.

(*L.U., 1932.*)

16. Show by means of a diagram how a three-electrode valve can be used to generate oscillations. Show in the diagram means whereby the direct current anode potentials and grid bias potentials are excluded from the high-frequency circuits.

(*C. & G., 1, 1932.*)

17. If the anode current of a valve generator is represented by the equation $i = A(\sin pt - \frac{1}{2} \cos 2pt)$, and if the anode circuit impedance consists of an inductance of 1 mH., having a resistance of 5 ohms, joined in parallel with a capacitance of 4 000 $\mu\mu\text{F.}$, find the fractional amplitude of the second harmonic current in the coil.

(*I.E.E., May, 1932.*)

18. A valve generator was adjusted so that the anode current was zero during one half-cycle. During the other half-cycle its wave-form was a peaky curve which may be represented by the equation

$$i = 4(\sin pt - \frac{1}{3} \sin 3pt) \text{ amperes.}$$

The anode potential was approximately $v = (10 - 5 \sin pt)$ kV. The power used in heating the filament was 1 kW. Find the efficiency of the generator and the power dissipated at the anode of the valve. Sketch a curve showing a complete cycle of anode current, anode potential, grid potential, and current in the anode circuit impedance.

(*I.E.E., May, 1932.*)

19. If the grid of a valve is made very positive to the anode it is found that, over a limited range, the anode current decreases when the anode potential is increased, thus producing a negative-resistance device. If an impedance in the anode circuit consists of an inductance L of resistance R , connected in parallel with a capacitance C , it is found that a steady alternating current may be produced in the impedance (Dynatron generator). If the slope resistance of the valve characteristic is $-r$ ohms, find the relation between L , C , R , and r , which must exist for oscillations to start, and also find the frequency of these oscillations. (*I.E.E., May, 1932.*)

20. Give a diagram and description of any valve circuit suitable for the generation of high-frequency oscillations having wavelengths of less than 1 metre. State how these oscillations can be modulated by audio frequencies.

(*I.E.E., Nov., 1933.*)

21. Give a diagram of an electron valve oscillator circuit suitable for the production of oscillations of a wavelength of the order of 50 cm. How can the wavelength of such oscillations be determined?

(*C. & G., Final, 1934.*)

22. Explain the operation of a valve oscillator in which a tuned circuit connected to the anode is coupled by mutual inductance to a coil connected to the grid. What causes the frequency of the oscillator to be different from the resonant frequency of the tuned circuit, and by what circuit adjustments would this difference be reduced to a minimum?

(*I.E.E., May, 1934.*)

23. A tuned circuit of $L = 500\mu\text{H.}$, $R = 20$ ohms and $C = 300\mu\text{F.}$, is connected across the grid and filament of a triode of $\mu = 10$ and $R_a = 50\,000$. In the anode circuit is a coil $L_a = 100\mu\text{H.}$, coupled with the inductance L by a mutual inductance of $20\mu\text{H.}$ Estimate the alteration the presence of the valve makes in the effective resistance of the tuned circuit.

(*I.E.E., May, 1934.*)

24. Show that it is possible to obtain sustained oscillations with any device, the voltage current characteristic of which has a negative slope. Describe an oscillator based on this principle.

(*I.E.E., May, 1934.*)

25. A three-electrode valve oscillator with the oscillatory circuit connected to the anode is required for a wave length of 600 metres. Taking the resistance of the oscillatory circuit as 30 ohms, and the internal resistance of the valve as 5 000 ohms, find what the values of the inductance and of the

capacitance should be in order that the valve output may be a maximum. (I.E.E., May, 1935.)

26. In a valve oscillator with a tuned anode circuit, a mutual inductance between grid coil and anode coil of $740\mu\text{H.}$ is required to start oscillations when the load is equivalent to a resistance of 20 ohms in the tuned circuit, but the mutual inductance must be increased to $980\mu\text{H.}$ when the equivalent load resistance is 40 ohms. If the valve has an internal resistance of 20 000 ohms and an amplification factor of 10, find the inductance and capacitance of the oscillatory circuit. Prove any formula used. (I.E.E., May, 1936.)

27. Show that the effective resistance of an oscillatory circuit in the anode circuit of a triode may be either reduced or increased by back coupling to a grid coil. If the oscillatory circuit consists of a coil of $200\mu\text{H.}$ inductance and 12 ohms resistance shunted by a condenser of $800\mu\mu\text{F.}$ capacitance, and if the amplification factor of the valve is 12 and its internal resistance is 20 000 ohms, what back coupling will be necessary (1) to reduce the effective resistance to 2 ohms; (2) to cause oscillations to commence? (L.U., 1938.)

28. The tuned-anode circuit of a radio-frequency oscillator consists of a condenser of capacitance $600\mu\mu\text{F.}$ in parallel with a coil of inductance $400\mu\text{H.}$ and resistance 6 ohms. The anode of the valve is connected to a tapping point on the coil: find the position of the tapping point to give maximum power output if the a.c. resistance of the valve is 18 000 ohms. (I.E.E., May, 1940.)

29. If the oscillatory circuit connected to the anode of a triode consists of a coil of $400\mu\text{H.}$ inductance and 25 ohms resistance in parallel with a condenser of capacitance $500\mu\mu\text{F.}$, and if the amplification factor of the triode is 5.5 and the anode a.c. resistance is 5 000 ohms, calculate from first principles the minimum value of the mutual inductance required with the grid circuit in order that oscillations may commence. (L.U., 1940.)

30. Derive the condition for self-oscillation of the magnetically coupled triode oscillator in which the oscillatory circuit is inserted between grid and filament. In a particular oscillator the constants of the oscillatory circuit are $L = 150\mu\text{H.}$, $C = 250\mu\mu\text{F.}$, $R = 15$ ohms, while the valve has a voltage amplification factor of 12 and an internal a.c. resistance of 8 000 ohms. Calculate the mutual inductance between the anode and grid coils for self-oscillation, and the generated frequency. What effect would be produced by increasing this mutual inductance to $10\mu\text{H.}$? (I.E.E., May, 1941.)

17. HETERODYNE RECEPTION

EXAMPLES 17

1. What is meant by heterodyne reception in the case of continuous wave wireless telegraphy? Sketch in detail and explain the action of any arrangements by which a single three-electrode valve can be used to effect reception of continuous wave signals. (L.U., 1925.)

2. Explain with a circuit diagram how heterodyne reception can be carried out with a single valve. Describe what happens as the tuning of the circuit is varied over a range of several hundred cycles per second about the frequency of the incoming signal. (C. & G., *Final*, 1926.)

3. Describe the heterodyne method of receiving continuous wave wireless signals. Show that if in the detector the rectified current is proportional to the square of the applied voltage, while in the remaining instruments the current is proportional to the voltage, then the current in the telephones is proportional to the signal strength. (I.E.E., *Oct.*, 1927.)

4. Describe the method of heterodyne reception of C.W. signals. What is the difference between autoheterodyne and separate heterodyne? Which system is to be preferred? (C. & G., 1, 1928.)

5. Explain fully the theory of the heterodyne reception of continuous-wave wireless telegraph signals, and describe, with a circuit diagram, how it is carried out in practice. (I.E.E., *May*, 1935.)

18. SUPERHETERODYNE RECEPTION

REFERENCE. *The Superheterodyne Receiver*, by Witts (Pitman).

EXAMPLES 18

1. Explain the superheterodyne system of reception, give a diagram of connections, and explain the advantages and disadvantages of the system. (L.U., 1926.)

2. Describe the supersonic heterodyne method of reception. What are important advantages of this method? What is the most serious disadvantage of the method, and how can it be overcome? (C. & G., *Final*, 1930.)

3. Discuss the advantages of the superheterodyne system of reception. (I.E.E., *Nov.*, 1931.)

4. Describe by means of a schematic diagram the principle

of a supersonic heterodyne receiver. What are the advantages and disadvantages of this type of receiver? How can the disadvantages be overcome? (I.E.E., May, 1933.)

5. What considerations govern the choice of intermediate frequency for a superheterodyne receiver? What are the advantages and disadvantages of (a) high intermediate frequencies, (b) low intermediate frequencies? Mention any circumstances which may render it desirable to use an intermediate frequency higher than the received frequency.

(I.E.E., Nov., 1933.)

6. Describe the principle of the superheterodyne method of receiving wireless broadcast signals and discuss its advantages over other methods of reception. Give an outline circuit diagram of a typical arrangement. (I.E.E., May, 1934.)

7. Describe the principle of operation of a supersonic heterodyne receiver. Give a circuit diagram suitable for the reception of C.W. telegraphy or telephony. (C. & G., Inter., 1934.)

8. Explain the superheterodyne method of receiving modulated wireless signals. Give a circuit diagram including approximate details of valve and circuit constants, of a set suitable for receiving broadcast signals on wavelengths of 200-500 metres.

(I.E.E., Nov., 1935.)

9. Explain the principle of operation of a superheterodyne receiver. What factors influence the choice of frequency for the intermediate circuit in such receivers? In some cases superheterodyne receivers are arranged to receive signals on frequencies above and below the intermediate frequency; how is this accomplished?

(C. & G., Inter., 1936.)

10. What is meant by the "superheterodyne" method of radio reception, and what are its special merits? Explain the operation of a hexode frequency-changer for use in a superheterodyne receiver. What is an "image signal," and how can it be eliminated?

(I.E.E., Nov., 1940.)

19. MODULATION

REFERENCES. *Telegraphy and Telephony*, by Mallett; *Wireless*, by Turner; *Radio Engineering*, by Terman; *Communication Engineering*, by Everitt.

If a carrier wave $C \sin \omega t$ is modulated by an acoustic wave $M \sin pt$, the modulated carrier may be represented by

$$(C + M \sin pt) \sin \omega t$$

$$= C \sin \omega t + (M/2) \cos (\omega - p)t - (M/2) \cos (\omega + p)t$$

The second and third terms of this expression represent

the lower and upper sidebands respectively, and contain frequencies equal to the difference and the sum respectively of the carrier and modulating frequencies.

Depth of modulation $m = M/C$.

Percentage modulation = $100M/C$.

Anode Choke Modulation

Voltage fluctuation at anode

$$= \frac{\mu\omega L V_g}{\rho_2 \sqrt{[1 + \omega^2 L^2 (1/\rho_1 + 1/\rho_2)^2]}}$$

where ρ_1 and ρ_2 are the anode resistances of the oscillating valve and control valve respectively; L is the inductance of the choke; μ is the amplification factor of the control valve, and V_g the voltage applied to its grid.

Distortion in the Receiver

If a carrier of frequency f is equally modulated by two acoustic tones, the higher frequency being N and the lower n , the ratio in which these two tones are received in a circuit of decrement δ is

$$\begin{aligned} \frac{I_n}{I_N} &= \sqrt{\frac{f^2\delta^2 + 4\pi^2 N^2}{f^2\delta^2 + 4\pi^2 n^2}} \\ &= \sqrt{\frac{1 + 4\pi^2 N^2/f^2\delta^2}{1 + 4\pi^2 n^2/f^2\delta^2}} \end{aligned}$$

If n is small, say less than 100 cycles,

$$\begin{aligned} I_n/I_N &\doteq \sqrt{[1 + (2\pi N/f\delta)^2]} \\ &\doteq \sqrt{[1 + (4\pi L N/R)^2]} \end{aligned}$$

If a modulated signal $(C + M \sin pt) \sin \omega t$ is applied to a rectifier, the characteristic of which is represented by

$$i = a + bv + cv^2,$$

the acoustic output is given by

$$i = c[CM \sin pt - (M^2/4) \cos 2 pt]$$

Power

The power transmitted by the carrier $\propto C^2$.

The power transmitted by each side band $\propto (M/2)^2$.

The total power transmitted $\propto C^2 + M^2/2$.

R.M.S. Values

The r.m.s. value of a modulated carrier is

$$\sqrt{\{(C^2/2) + (M^2/4)\}}$$

The ratio of the r.m.s. values of the modulated to the unmodulated carrier is

$$\sqrt{(1 + \frac{1}{2}m^2)}$$

EXAMPLES 19

1. What is meant by a "modulated wave"? Describe the "anode choke" method of modulating the high frequency currents in an aerial by sound waves. (*C. & G., Final, 1927.*)

2. Describe the choke control method of wireless telephone transmission, explaining the considerations underlying the determination of the relative sizes of the valves employed.

(*I.E.E., Oct., 1927.*)

3. Give a theoretical justification for looking upon a modulated wave in wireless telephony as consisting of a "carrier wave" and "side bands." Explain how good reception is possible when only one side band is transmitted.

(*I.E.E., Oct., 1927.*)

4. Give a diagram showing how a valve transmitter can be modulated by speech currents for telephone transmission, and explain briefly the action.

(*C. & G., 1, 1929.*)

5. Explain, with wiring diagrams, the method of modulating a small triode telephone transmitter by (a) grid control, (b) choke control. Explain, with references to the triode characteristics, the action of both methods of control.

(*I.E.E., Nov., 1929.*)

6. What are meant by the terms "modulation" and "demodulation" of a high-frequency current? Show how each process may be carried out by the use of valves whose characteristic curves follow a square law. How may distortion of the original signal be avoided?

(*L.U., 1930.*)

7. Explain, with diagrams, two methods whereby a valve transmitter can be modulated by speech currents. What is meant by depth of modulation or percentage modulation? How can this be measured in an actual radio telephone transmitter?

(*C. & G., Final, 1930.*)

8. The input circuit of a radio receiver has a logarithmic decrement of 0.0314 when tuned to a frequency of 800 kc. The carrier wave of a station working on this frequency is equally modulated by tones of 50 cycles and 5 000 cycles.

In what ratio will these two tones be received, assuming that the remainder of the receiver has a flat response?

(*C. & G., Final, 1931.*)

9. An acoustically modulated e.m.f. acts on an aerial tuned to the carrier frequency. Explain why the modulation ratio of the voltage applied to the detector is less than the modulation ratio of the signal e.m.f. A voltage $V = E(1 + m \cos nt)\cos \omega t$ is applied to a rectifier which has a parabolic characteristic $i = cV^2$. Derive an expression for the acoustic frequency output of the rectifier. (*I.E.E., Nov., 1931.*)

10. Explain the anode-choke method of producing modulated high-frequency currents. If the amplification factor of the control valve is 10, the internal resistances of the control and oscillating valves are 10 000 and 50 000 ohms respectively, and the inductance of the choke is 10 H., estimate the variation of the anode potential of the oscillating valve produced by a sinoidal variation of potential at the grid of the control valve of amplitude 3 V. and frequency 1 000 cycles per sec.

(*L.U., 1932.*)

11. Explain, with the help of characteristic curves, why the output of a simple valve generator depends on the steady potential of the anode and the grid. Show how this property may be used to modulate the output of a telephony transmitter, and sketch a simple system whereby this may be carried out.

(*I.E.E., May, 1932.*)

12. Describe some arrangement for measuring the depth of modulation of a high-frequency current.

(*I.E.E., May, 1932.*)

13. A detector valve has a resistance of 150 000 ohms in the anode circuit, and is used to rectify a voltage whose carrier frequency is 150 kilocycles per sec., modulated with a frequency of 5 kilocycles per sec. A by-pass condenser is connected across the resistance, and its capacitance is such that its presence reduces to 5 000 ohms the impedance of the anode circuit to the carrier frequency. By how much will it reduce the impedance to the modulation frequency?

(*I.E.E., May, 1932.*)

14. A straight-line rectifier is operated by a highly selective receiver, which is acted on by two modulated signals; the receiver is tuned to the carrier of one modulated signal, but is appreciably out of tune to the other. Draw and discuss the envelope of the rectified current, and discuss the result of this current in an acoustic receiver.

(*I.E.E., Nov., 1932.*)

15. What is meant by the terms "low-power modulation" and "high-power modulation" applied to a radio-telephone

transmitter? What are the advantages of each type of modulation? State approximately the maximum percentage modulation which can be obtained in practice in each case without serious loss of quality in the transmission.

(*I.E.E., May, 1933.*)

16. How can the percentage modulation of a radio-telephone transmitter be determined (a) at the transmitter, and (b) at a distant receiving station?

(*I.E.E., May, 1933.*)

17. Explain what is meant by a single side band suppressed carrier radio-telephone system. Give a schematic diagram of the apparatus necessary at the transmitter for the production of this type of emission. Mention any advantages of the system for long waves and for short waves.

(*C. & G., Final, 1934.*)

18. Show how a valve having a square-law characteristic may be used to produce modulated high-frequency currents. Discuss the nature of the modulated currents and their reception by a valve of square-law characteristics.

(*I.E.E., May, 1934.*)

19. Explain what is meant by modulating a carrier wave. Show that the effects of amplitude modulation is to produce two side bands of frequency, one above and the other below the carrier frequency. Examine the effect on the use of the system for the transmission of information, of suppressing one of the side bands. If a wireless transmitter radiates 4 kW. with an unmodulated carrier wave and 5.2 kW. when the carrier wave undergoes a sinoidal variation of amplitude, calculate the percentage modulation employed. Assume negligible distortion.

(*L.U., 1934.*)

20. What is the nature of a modulated high-frequency voltage? Prove any statement made, and explain how the signal distortion obtained on rectification by a square-law rectifier may be avoided.

(*I.E.E., Nov., 1934.*)

21. A high-frequency oscillation of frequency f is modulated by a frequency p so that the resultant current is represented by the expression

$$i = A(1 - B \sin 2\pi pt) \sin 2\pi ft.$$

Resolve this expression into the carrier and two side frequencies. What is meant by percentage modulation, and what is the percentage modulation in the above case? A transmitter supplies 10 kW to the aerial when unmodulated; what will be its output when modulated 100 per cent?

(*C. & G., Inter., 1935.*)

22. Show that a modulated high-frequency current contains

two additional frequencies for each modulation frequency. Explain how speech modulation of high-frequency currents is effected in wireless telephony. (*I.E.E., May, 1935.*)

23. Show that with single side-band transmission, a square-law detector receives without distortion. If the anode current of the detector is given in mA. by $I_a = 0.5(6 + V_g)^2$ find the signal current when the amplitude of the grid voltage of the carrier is 2.5 volts and of the side band 1.0 volt.

(*I.E.E., Nov., 1935.*)

24. Describe the anode-choke method of producing speech-modulated wireless signals. Give an outline diagram, including approximate valve and circuit constants, of a transmitting circuit suitable for broadcasting 10 kW. at 250 metres.

(*I.E.E., Nov., 1935.*)

25. Describe two methods of modulating a high-frequency oscillator with speech frequency. A radio telephone transmitter in the unmodulated state has a carrier output of 10 kW. and can be modulated to a maximum of 80 per cent by single frequency tone before overloading. To what value can the carrier power be increased if a limit of 50 per cent modulation is imposed?

(*C. & G., Inter., 1936.*)

26. What is meant by frequency modulation of a carrier wave? What are the advantages and disadvantages of this system compared with amplitude modulation, and why is it difficult to achieve a satisfactory practical application of the method? An oscillatory circuit with an inductance of 0.4mH., a capacitance of $63\mu\mu\text{F.}$ and a resistance of 4 ohms is used to receive a carrier wave having a frequency modulation of 1.5 kc. per sec. Give a suitable value for the carrier frequency and estimate the corresponding percentage modulation of the received current.

(*L.U., 1936.*)

27. A carrier frequency voltage $e = A \sin \omega t$, is modulated by a low-frequency voltage, $e = B \sin pt$. The depth of modulation is M . If the modulator has a square law characteristic, derive an expression for the output from the modulator in terms of carrier and side-bands.

(*C. & G., Inter., 1937.*)

28. A sinoidal carrier having a voltage amplitude V is modulated by a sinoidal tone having a voltage amplitude v . Deduce a formula to give the resulting instantaneous value of carrier and side-bands. If the ratio of v to V is 0.6, find the relative power in the carrier and side-bands.

(*C. & G., 3, 1939.*)

29. An aerial coupled to a valve oscillator radiates a sinoidal carrier wave, and a modulator is provided so that a

simple harmonic variation in the amplitude of the wave can be produced. If the r.m.s. value of the aerial current before modulation is 12·5 A. and during modulation is 14 A., calculate the percentage modulation employed assuming no distortion.

(*I.E.E.*, May, 1939.)

30. The r.m.s. value of a radio-frequency voltage before modulation by a sine-wave audio-frequency voltage is 50 volts, and after modulation 55 volts. Calculate the percentage modulation.

(*I.E.E.*, Nov., 1940.)

31. A carrier wave is amplitude modulated at audio frequency. Deduce an expression to show that two side-bands are produced. What is the relative power in each side-band and carrier when the modulation coefficient is 0·5?

(*C. & G.*, 3, 1941.)

20. TRANSMITTERS

REFERENCES. *Admiralty Handbook of Wireless Telegraphy; Wireless*, by Turner; *Modern Radio Communication*, by Reyner.

EXAMPLES 20

1. Draw a circuit diagram explaining how speech modulated, high-frequency currents for wireless telephony may be produced in an aerial.

(*C. & G.*, 1, 1926.)

2. What considerations govern the design of a valve oscillator transmitting circuit for, say, 1 kilowatt output into the aerial?

(*C. & G.*, *Final*, 1926.)

3. A 6 kW. valve transmitter is required for a wavelength of 1 500 metres. The antenna capacity is 0·002 microfarad and the resistance 10 ohms. Work out the value of aerial tuning inductance and estimate the value of the anode tap, grid condenser, and grid leak, and the high-frequency choke coil in the direct current supply. Assume glass valves of 600-watt dissipation worked at 70 per cent efficiency, and a direct current supply from rectifiers at 10 000 volts.

(*I.E.E.*, Oct., 1926.)

4. Describe the essential features in the working of a small telegraph transmitting station using continuous waves.

(*C. & G.*, 1, 1927.)

5. Give an account of the various ways in which a valve

generator system may be coupled to an aerial, and discuss their relative advantages. (C. & G., *Final*, 1927.)

6. Describe a method of keying (a) a high-power, long-wave transmitter, and (b) a short-wave beam transmitter.

(I.E.E., *May*, 1930.)

7. Give a circuit diagram and brief description of a radio telephone transmitter. Show clearly how the output is modulated by speech currents.

(C. & G., 1, 1931.)

8. (a) State three different methods used in keying valve radio telegraph transmitters, mentioning any advantages or disadvantages.

(b) Give a circuit diagram and a brief description of a master oscillator controlled valve transmitter, working off an a.c. supply, which can be used for radio telephony or radio telegraphy.

(C. & G., *Final*, 1932.)

9. Draw a wiring diagram for a complete transmitter of about 100 kW. capacity and medium wavelength. Describe the purpose of each stage and the method of keying.

(I.E.E., *Nov.*, 1932.)

10. What methods are adopted in practice to prevent the radiation of radio frequency harmonics by a valve transmitter?

(I.E.E., *May*, 1933.)

11. Give a circuit diagram and description of a radio-telephone transmitter having a master oscillator drive. Explain clearly how the output is modulated by audio frequency currents.

(I.E.E., *Nov.*, 1933.)

12. Give a diagram and description of a $1\frac{1}{2}$ -kW. ship's interrupted continuous-wave telegraph transmitter with rectifier for high-tension supply from a single-phase alternator. Show how keying is effected, and how the valve filament supply is kept constant when keying.

(I.E.E., *Nov.*, 1933.)

13. Describe a method of producing inverted speech for privacy purposes in radio telephony.

(C. & G., *Final*, 1935.)

14. Describe with sketches the construction of a high-power cooled-anode valve for a short-wave transmitter. Give a circuit diagram with a brief description of the output stage of a radio-telephone transmitter designed to work on short waves. The output of the transmitter is 20 kW. carrier power, which is fed to a balanced transmission line of 500 ohms impedance. If the transmitter is modulated 100 per cent, what is the maximum peak voltage across the output?

(C. & G., *Inter.*, 1937.)

21. FREQUENCY CONTROL AND STABILIZATION

REFERENCES. *Wireless*, by Turner; *Telegraphy and Telephony*, by Mallett; *Admiralty Handbook of Wireless Telegraphy*; *Quartz Oscillators*, by Vigoureaux.

Quartz Crystals

The following formulae refer to thickness vibrations only—

X-cut plates:

Frequency $f = 2870/t$ kc/s where t is the thickness of the plate in mm.

The temperature coefficient is $- 21 \times 10^{-6}$ per 1° C.

Y-cut plates:

For thin plates, $f = 1960/t$ kc/s.

The temperature coefficient is $+ 90 \times 10^{-6}$ per 1° C.

EXAMPLES 21

1. Describe, with circuit diagrams, the use of a quartz crystal as a frequency standard and also as a frequency control for a valve generator. (*I.E.E.*, Nov., 1929.)

2. Give diagrams showing how a quartz crystal may be used to control the frequency of a valve generator. Replace the quartz by its equivalent network and thereby explain the action of the system. (*I.E.E.*, May, 1930.)

3. Describe the methods which are used for maintaining a constant frequency for transmitting stations of (a) moderate frequency, (b) very high frequency. (*I.E.E.*, May, 1931.)

4. Draw diagrams showing two methods by which a quartz crystal can be used to control the frequency of a valve generator and describe suitable mountings for the crystal. Draw the electrical network which is equivalent to the crystal. (*I.E.E.*, Nov., 1931.)

5. Explain how quartz-crystal oscillators can be used in conjunction with a valve to generate high-frequency currents. Discuss the advantages, difficulties, and applications of such generators. (*L.U.*, 1932.)

6. Discuss the problem of maintaining constant the frequency of a telephone transmitter of about 30 m. wavelength. and describe various methods which are used for this purpose,

How does the frequency shift compare at present with the necessary width of a telephone channel?

(*I.E.E., May, 1932.*)

7. Describe, with wiring diagrams, some methods of stabilizing the frequency of a transmitting station of 30 m. wavelength. What precautions should be used in operation to maintain the frequency of an unstabilized station?

(*I.E.E., Nov., 1932.*)

8. Discuss the use and care of crystals as frequency stabilizers and as standards of frequency: give diagrams of one or more suitable forms of holders for plate and for bar crystals.

(*I.E.E., Nov., 1932.*)

9. What properties of a quartz crystal enable it to be used in a valve oscillator? Give a circuit diagram and an explanation of the action of such an oscillator, and explain its advantages and disadvantages compared with other valve oscillators.

(*L.U., 1933.*)

10. Describe, with a diagram, a valve oscillator circuit having inherently a high constancy of frequency without mechanical stabilizing devices, and suitable for the beating oscillator of a short-wave receiver.

(*I.E.E., May, 1933.*)

11. What are the reasons for the use of piezo electric crystals for frequency control? What precautions are necessary if the best results are to be obtained? What approximately are the highest frequencies for which quartz crystals can be manufactured and used? How can frequencies above this limit be controlled?

(*C. & G., Final, 1934.*)

12. Describe, with a circuit diagram, the principle of operation of a frequency changer circuit, using valves, suitable for use in connection with a tuning fork or crystal frequency control equipment on a radio transmitter.

(*C. & G., Final, 1935.*)

13. What is the piezo-electric effect? What materials exhibit the effect? What processes or preparation is necessary in materials in order to obtain the effect? How is the piezo-electric effect utilized in equipment for radio transmitting and reception?

(*C. & G., Final, 1936.*)

14. A quartz crystal oscillator is required for a short-wave telephony transmitter. Describe the various steps to be taken in the preparation of the crystal from the initial to the final stage. What degree of frequency stability would you expect to obtain?

(*C. & G., 3, 1940.*)

15. Describe how a quartz crystal can be employed to control the frequency of a triode oscillator. Discuss the conditions that determine the constancy of the frequency.

What is meant by *X*- and *Y*-cut crystals and what are their relative merits? (L.U., 1940.)

22. RECEIVERS

REFERENCES. *Modern Radio Communication*, by Reyner; *Admiralty Handbook of Wireless Telegraphy*.

EXAMPLES 22

1. Describe what happens in a simple crystal receiving set when a continuous wave produces currents in the aerial.

(C. & G., 1, 1926.)

2. If two valves are available for the reception of broadcast signals, discuss the various considerations that will decide the manner in which they should be used.

(C. & G., *Final*, 1927.)

3. In a selective valve receiver the aerial circuit is loosely coupled to the first valve. How would you modify this receiver to make it less selective for search or "stand by" purposes? Give a diagram of such a receiver having a reacting detector and two low-frequency valves with necessary change-over switches.

(C. & G., 1, 1929.)

4. Discuss the principal causes of the imperfections of reproduction of music which are likely to occur in a wireless broadcast receiver, but omit the acoustic imperfections of the loud speaker.

(I.E.E., *Nov.*, 1929.)

5. Give a circuit diagram of a valve receiver suitable for the reception of modulated waves between 300 and 500 m., consisting of one stage of high-frequency amplification, detector, and one stage of low-frequency amplification. Include in the diagram switch connections for stand-by and selective adjustments whereby the high frequency stage is disconnected and the aerial connected to the detector valve in the stand-by position. Indicate clearly the method of rectification employed.

(C. & G., *Final*, 1930.)

6. Describe a complete receiving circuit for a telephone service at about 30 m. wavelength.

(I.E.E., *May*, 1930.)

7. Give a circuit diagram and brief description of a radio receiver suitable for the reception of spark, I.C.W. or C.W. signals between 500 and 2 500 m. wavelength and possessing the following features—

Tuned coupled aerial circuit, one high-frequency stage, detector, one low-frequency stage, separate heterodyne.

(C. & G., 1, 1931.)

8. A receiving aerial has an effective height of 5 m. and is

acted on by an incident field strength of 3 mV./m. It is tuned to the incoming signal by means of an inductance, and this tuned circuit has a decrement of 8 per cent. The p.d. across this tuning inductance is transferred to the rectifier by means of a high frequency amplifier whose magnification is 8. Calculate the voltage applied to the rectifier. (*I.E.E., May, 1931.*)

9. Make an outline circuit diagram of a broadcast receiving set containing a screen grid valve, a rectifying valve and a pentode valve, and a loud-speaker. The wavelength range required is from 200 to 500 m. Give approximate values of inductances and condensers and of the voltages and currents at various points. (*L.U., 1932.*)

10. Explain the action of a radio receiver when used to convert radio telephony signals into speech signals. How does the sharpness of tuning of the receiver affect the quality of the speech output? (*C. & G., 1, 1932.*)

11. Describe, with wiring diagrams, a suitable receiver system for the reception of telephony at a wavelength of about 15 m. (*I.E.E., May, 1932.*)

12. Describe, with wiring diagrams, a receiver suitable for a radio telephone trunk, operating at a wavelength of about 30 m. (*I.E.E., Nov., 1932.*)

13. Describe, with a diagram, the circuit and action of a super-regenerative receiver. State the range of wavelength for which this receiver is most suited, and mention any of its advantages and disadvantages. (*C. & G., Final, 1933.*)

14. Describe a method whereby the audio frequency output of a broadcast receiver is automatically controlled to compensate for variations in the level of the received signal due to fading. (*I.E.E., Nov., 1933.*)

15. What advantage is derived from using a coupled circuit in a receiver? How is the response of the receiver to incoming signals modified as the coupling is gradually increased from 'zero to a maximum'? (*C. & G., Prelim., 1934.*)

16. Why is retroaction used in some types of receiver? Indicate by diagrams three ways in which retroaction can be applied to a receiver and mention any disadvantages attending its use. (*C. & G., Prelim., 1934.*)

17. What are the advantages of automatic gain control when applied to a radio-telephone receiver? How does the time of operation of the control affect the performance of the receiver? Give a diagram of a control system, suitable for a high-class broadcast receiver. What can be done to avoid excessive noise when tuning between stations?

(*C. & G., Final, 1934.*)

18. Explain what is meant by diversity reception. Indicate by means of a circuit diagram how radio-telegraph reception on this system is carried out in practice.

(*C. & G., Final, 1934.*)

19. Why is a detector necessary in order to receive wireless signals? What apparatus additional to a detector is necessary for the reception of continuous waves? Describe any method whereby I.C.W. signals can be audibly received without a detector.

(*C. & G., Prelim., 1935.*)

20. Describe, with a diagram, the principles of operation of a super-regenerative type of receiver. What are the advantages of this type of receiver, and what is the range of wave length for which it is best suited? (*C. & G., Inter., 1935.*)

21. Describe one system of push button tuning of a receiver.

(*C. & G., 2, 1939.*)

22. Explain the need and method of application of automatic gain control in a broadcast receiver. Give some approximate idea of the output level of such a receiver for varying input levels.

(*C. & G., 2, 1940.*)

23. Under what circumstances is automatic volume control desirable in a radio receiver? Describe, with the aid of a circuit diagram, a method of obtaining delayed automatic volume control in a superheterodyne receiver. (*L.U., 1940.*)

24. Describe how the fidelity and selectivity of a broadcast receiver can be measured.

(*C. & G., 2, 1941.*)

23. SELECTIVITY

If m is the modulation ratio of a carrier wave of frequency f , and N is the modulating frequency, the modulation of the wave received in a resonant LCR circuit of decrement δ is reduced to

$$m_1 = \frac{m}{\sqrt{[1 + (2\pi N/f\delta)^2]}} = \frac{m}{\sqrt{[1 + (4\pi LN/R)^2]}}$$

The attenuation in respect to the carrier is

$$\begin{aligned} & 10 \log \{1 + (2\pi N/f\delta)^2\} \text{ decibels} \\ & = 10 \log \{1 + (4\pi LN/R)^2\} \text{ decibels} \end{aligned}$$

EXAMPLES 23

1. What is meant by the selectivity of a receiving set, and upon what does it depend? In receiving the waves sent out

for wireless telephony, why is it necessary that the tuning should not be too sharp? (C. & G., 1, 1926.)

2. What is meant by the term "selectivity" as applied to a wireless receiving circuit? Describe, and explain methods of obtaining good selectivity in a broadcast receiver without seriously impairing the quality of the reproduction. A simple receiver includes a tuned circuit having the following constants—

$$\text{Inductance} = 4.9 \times 10^{-4} \text{ henries.}$$

$$\text{Capacity} = 1\,000 \text{ micro-microfarads.}$$

$$\text{Resistance} = 9.8 \text{ ohms.}$$

Determine the attenuation of a side band due to a frequency of 2 000 cycles per sec. (L.U., 1933.)

24. FIELD STRENGTH

Neglecting absorption, the field strength due to a distant transmitting station is given by

$$\mathcal{F} = 377(hI/\lambda d) \text{ volts per metre}$$

where h = effective height of transmitting aerial in metres,

d = distance in metres,

λ = wavelength in metres,

I = aerial current in amperes.

For an imperfectly conducting earth, the field strength $F = \mathcal{F}S$, where $S = \varepsilon^{-kd/\sqrt{\lambda}}$ represents the attenuation factor.

If F_1 and F_2 are the field strengths and S_1 and S_2 are the attenuation factors corresponding to distances d_1 and d_2 respectively, then

$$S_1 = (F_2/F_1)^{d_1/(d_2 - d_1)}$$

and

$$S_2 = (F_2/F_1)^{d_2/(d_2 - d_1)}$$

The power radiated from an aerial is given by

$$W = 1.584h^2I^2/\lambda^2 \text{ kilowatts,}$$

and hence

$$\mathcal{F} = (300\sqrt{W})/d \text{ volts per metre}$$

The magnetic field H in lines per sq. cm. is related to the electrostatic field strength F in volts per cm. by the equation

$$F = 300H$$

EXAMPLES 24

1. What is meant by field strength? On what factors does the field strength of a distant transmitting station depend? How can the field strength of such a station be measured? What precautions are necessary in making such measurements?

(*C. & G., Final, 1928.*)

2. If 100 kW. of energy are radiated from an antenna of 100 m. effective height, on a wavelength of 5 000 m., what would be the strength of the electric field in microvolts per metre at a distance of 100 kilometres, assuming that no absorption effects are present?

(*C. & G., Final, 1932.*)

3. The field strength of a station transmitting on 40 kc/s is measured at a distance of 50 kilometres and found to be 30 millivolts per metre. At a distance of 200 kilometres the field is 2 millivolts per metre. What is the attenuation factor of the wave?

(*C. & G., Final, 1933.*)

4. Explain the nature of the electromagnetic waves propagated from a vertical aerial. If the electric field strength of a plane wave is 0.1 volt per metre, what is the magnetic field strength in lines per sq. cm.?

(*I.E.E., May, 1934.*)

5. Describe any method of measuring the field strength of a short-wave radio signal. What special features, if any, distinguish the apparatus from that used for long and medium wave measurements?

(*C. & G., Final, 1935.*)

6. Explain what is meant by the field strength of an electromagnetic wave, and why the field strength produced at a distant point by a short-wave transmitting station is liable to undergo considerable variations. Describe any method by which field strength may be measured at a wavelength of, say, 50 m.

(*I.E.E., May, 1941.*)

25. AERIAL RESISTANCE AND EFFICIENCY

REFERENCES. *Admiralty Handbook of Wireless Telegraphy; Telegraphy and Telephony*, by Mallett.

The radiation resistance of an aerial is given by

$$\begin{aligned} r &= 1584 (h^2/\lambda^2) \text{ ohms} \\ &= 1.76 \times 10^{-8} h^2 f^2 \text{ ohms} \end{aligned}$$

where h is the effective height expressed in the same units as λ in the first equation and in metres in the second, and f is the frequency in kilocycles.

The power radiated is

$$W = I^2 r$$

$$= 1.584 (hI/\lambda)^2 \text{ kilowatts}$$

If H is the actual height, the effective height is $h = kH$ where k is the aerial form factor. This factor depends upon the shape of the aerial as indicated approximately in the following table, where L is the length of the horizontal roof for $\bar{\text{—}}$ aerials and half the total roof for flat top T aerials.

L/H	0	.2	.5	1	2	5	10
k	0.64	0.74	0.83	0.9	0.96	0.99	1.0

The radiation constant = hI metre-amperes.

The aerial efficiency = r/R where R is the total aerial resistance.

EXAMPLES 25

1. Explain the variation of the total effective or equivalent resistance of an aerial with variation of wavelength, discussing in detail the causes of the variations of the various component resistances. (L.U., 1925.)

2. Give sketches showing the polar diagrams of the radiation in a vertical plane from a short-wave antenna excited on (a) its fundamental, and (b) its third harmonic. The method of exciting the antenna should also be shown. (I.E.E., Oct., 1926.)

3. The current measured at the base of a radio-telegraphic antenna is 220 amperes. The antenna is of L-form with a "radiation height" of 160 ft. and the wavelength employed is 8 000 m. What is the amount of energy radiated? (I.E.E., Oct., 1926.)

4. What are the various quantities that form the total "aerial resistance"? Draw a curve showing how the various parts and the total depend upon the wavelength. (C. & G., 1, 1927.)

5. Enumerate and explain the various sources of loss in aerial circuits and discuss their variation with wavelength. Give a definition of "effective resistance" and "radiation resistance." (I.E.E., Oct., 1927.)

6. Explain what are meant by the capacitance, inductance, and resistance of an aerial, and show how to measure these quantities. Modification of the earth system of a certain transmitting aerial caused its resistance to be reduced to one-quarter of its previous value. It was then found that the aerial current had to be increased by 10 per cent in order to produce the same field strength at a distant point. Calculate the improvement in the efficiency in the aerial.

(*I.E.E., Nov., 1929.*)

7. Describe, with diagrams, the approximate distribution of current along the length of a vertical aerial when the frequency of the current corresponds to a wavelength (*a*) much greater than, (*b*) roughly equal to, and (*c*) less than four times the length of the aerial. Describe any experiments which have been made to measure the distributions. Explain the action and purpose of the phasing coils used in the separate members of an antenna array for beam transmission.

(*I.E.E., Nov., 1929.*)

8. An aerial has an effective height of 100 m. and the current at the base is 450 amperes r.m.s. at 40 000 cycles per sec. What is the power radiated? If the total resistance of the aerial circuit is 1.12 ohms, what is the efficiency of the aerial?

(*C. & G., Final, 1930.*)

9. What is meant by the radiation resistance of an aerial? The radiation resistance *R*, in ohms, is related to the height *l* in metres and the frequency *n* in cycles per sec. by the formula—

$$R = \frac{16}{9} \cdot \frac{l^2 n^2}{10^{14}} \text{ ohms}$$

Assuming that this formula is valid for aeriels whose height is one-quarter wavelength, find the radiation resistance of such an aerial.

(*I.E.E., Nov., 1931.*)

10. The following measurements were taken on an antenna by adding inductance and measuring the wavelength—

Added inductance in micro-henries	7.3	13.9	24.5	41.5	66.8	89	109.2	129
Wavelength in m.	522	541	573	620	688	738	782	826

Determine by means of a graph the inductance, capacitance, and natural wavelength of the antenna. If the effective height of the antenna is 30 m., what power would be radiated on 600 m. with a current of 10 amperes in the base of the antenna?

(*C. & G., Final, 1933.*)

11. Deduce an expression for the radiation resistance expressed in ohms of a vertical aerial in terms of its effective height and wavelength of the radiation, given the expression $E = (4\pi I_e H_e / 10\lambda d) \sin \theta$ for the component of the electric force in e.m.u. at an angle $(90 - \theta)$ from the earth's surface and distance d from a vertical aerial of effective height H_e carrying a current I_e amperes. Point out any assumptions made and show how they affect the accuracy of the expression obtained. A transmitting aerial having an effective height of 200 ft. takes a current of 50 amperes (r.m.s.) at a frequency of 480 kc. per sec. Calculate: (1) the radiation resistance of the aerial; (2) the power radiated; (3) the aerial efficiency for a total aerial resistance of 50 ohms. (L.U., 1933.)

12. Describe a method whereby the resistance of a large transmitting antenna can be accurately determined.

(I.E.E., May, 1933.)

13. The aerial at a transmitting station has an effective height of 150 metres and the current at the base is 700 A. at 16 000 cycles per second. What is the power radiated? If the capacitance of the aerial is 0.04 microfarad what is the voltage across the lead-out insulator? Give a sketch and brief description of a suitable lead-out insulator for such a station.

(C. & G., Final, 1937.)

14. What do you understand by "effective height" and "radiation resistance" of an aerial? If the effective height of an aerial is 1/100th of the length of the wave emitted, what is its radiation resistance?

(C. & G., 1, 1938.)

15. Explain how and why the efficiency of a wireless aerial varies with the wavelength of the radiation. If a certain aerial has a total effective resistance R given by the expression $R = (30/\sqrt{\lambda}) + (4 \times 10^{-3})\lambda + 8 \times 10^4/\lambda^2$ ohms, where λ is the wavelength in metres, calculate the aerial efficiency for a wavelength of 400 metres.

(I.E.E., Nov., 1939.)

16. A receiving aerial has a total resistance of 12 ohms, when receiving a signal of frequency 500 kc/s. If the effective height of the aerial is 30 metres, what is its radiation efficiency?

(C. & G., 2, 1940.)

26. DIRECTIONAL TRANSMISSION AND RECEPTION

REFERENCES. *Wireless*, by Turner; *Short Wave Wireless Communication*, by Ladner and Stoner (Chapman & Hall); *Admiralty Handbook of Wireless Telegraphy*; *Principles of Radio Engineering*, by Glasgow.

In an antenna array with finite spacing the total field in a direction making an angle θ with the normal to the array is

$$F = F_1 \frac{\sin (N\alpha/2)}{\sin (\alpha/2)}$$

where F_1 = field due to one aerial

N = number of vertical aerials

α = phase difference between the radiations of consecutive aerials in the given direction.

Also $\alpha = \{(2\pi a/\lambda) \sin \theta\} \pm \phi$

where a = spacing of the aerials

λ = wavelength

ϕ = phase difference between the currents in adjacent aerials.

F vanishes when $N\alpha/2 = \pi, 2\pi$, etc.

If the aerial currents are in phase, $\phi = 0$ and the first zero occurs when

$$\sin \theta = \lambda/Na.$$

The angular width of the broadside beam is then 2θ .

EXAMPLES 26

1. Describe any type of directional antenna array suitable for short wave transmission or reception and indicate carefully how it is connected to the feeders. An antenna array consists of eight vertical aerials in a straight line spaced half a wave length apart and energized equally in phase. What will be the angular width of the forward beam in the horizontal plane?

(*C. & G., Final, 1935.*)

2. State and explain the essential principles underlying the operation of the aerial array as used for the "beam system" of wireless communication. Show how the spacing of the component conductors of the array affects the shape of the polar curve of radiation from it, and state the means employed to obtain propagation of the wave at the best zenithal angle. Why is the direction of the beam leaving England for New York practically North-west although the latitude of New York is about the same as that of Madrid? (*L.U., 1935.*)

3. Derive expressions for the polar diagram in the horizontal plane for an antenna array consisting of N elements

spaced half a wavelength apart in a straight line energized in phase. Derive a similar expression for the polar diagram of an array system having elements spaced half a wavelength and alternate elements phased 180 degrees from the remainder, in order to secure maximum radiation in the line of elements. How does the sharpness of directivity compare in the two cases?

(*C. & G., Final, 1937.*)

4. An antenna array consists of 10 vertical aerials in a straight line spaced half a wavelength apart and energized equally in phase. Deduce the angular width of the forward beam in the horizontal plane.

5. An antenna array consists of 10 vertical aerials energized equally in phase. The aerials are spaced 15 metres apart and transmit signals on a wavelength of 20 metres. What will be the angular width of the forward beam in the horizontal plane?

6. A beam array consists of N similar vertical radiators in the same plane (normal to the direction between the transmitting and receiving station). The height of all radiators above the ground is the same and the separation between adjacent radiators is half a wavelength. Assuming all radiators have the same resistance, what is the gain in decibels of the array with reference to a single radiator? What gain would you expect to obtain from a correctly designed reflector curtain? If the number of radiators in the array were increased to $2N$, what additional gain would you expect? What does this suggest regarding the limitations of the gain of an array?

(*C. & G., 2, 1938.*)

7. Two similar vertical aerials spaced half a wavelength apart, their lower ends being the same height from the ground, are fed in anti-phase, the maximum amplitude of the current in each radiator being equal. A single vertical comparison aerial similar in all respects to each of the other two aerials has the same maximum amplitude of current. Assuming that there is no interaction between the single aerial and the combination, compare the field strengths due to (a) the combination of the two aerials, and (b) the single comparison aerial, at equally large distances in (1) the direction of the line joining the two aerials, (2) the direction normal to this line, and (3) in the direction making an angle of 30° to this line.

(*C. & G., 2, 1939.*)

8. Two vertical aerial wires carry high-frequency currents in phase with each other and are separated by a distance of half a wavelength. Calculate the strength of the radiated field in a direction inclined at (a) 60° to the plane of the wires,

(b) 30° to the plane of the wires, in terms of the field strength at right angles to the plane of the wires. (*I.E.E., May, 1939.*)

9. Two vertical aerials, similar in all respects, are situated a fraction of a wavelength apart. How would you connect them to form a directional aerial, and what would be the shape of the polar diagram of this directional aerial in the horizontal plane? (*C. & G., 1, 1940.*)

10. What is meant by the gain of an array? Explain the action of a tuned reflector of an array. One broadside array covers four times the area of another. What would be the approximate gain in decibels of the larger over the smaller array? (*C. & G., 2, 1941.*)

27. RECEIVING AERIALS

REFERENCES. *Modern Radio Communication*, by Reyner; *Admiralty Handbook of Wireless Telegraphy*.

If F is the field strength in volts per metre and h the effective height of the receiving aerial, the received e.m.f. will be

$$E = Fh \text{ volts}$$

If R is the resistance of the circuit the current is

$$I = Fh/R$$

The voltage across the aerial coil is FhZ/R , where Z is its impedance.

The voltage received in a frame in the plane of propagation of the wave is

$$E = 2\pi FAN/\lambda \text{ volts}$$

where A is the frame area in square metres, N its number of turns, F the field strength in volts per metre, and λ the wavelength in metres.

EXAMPLES 27

1. A small receiving aerial has a vertical height of 8 m. and a horizontal roof of length 20 m., a capacitance of $160 \mu\mu\text{F.}$, and an effective resistance of 80 ohms at a frequency of 1 000 kc. per sec. Estimate the p.d. across the tuning inductance produced by an incident field strength of 1 mV. per m.

(*I.E.E., May, 1930.*)

2. Write a short account of the nature of electromagnetic waves. Find the voltage induced by a plane wave of field strength 0.01 volt per metre and wavelength 300 m. in—

(1) A vertical aerial 8 m. high;

(2) A frame aerial 1 m. square of 12 turns, the plane of the frame being in the plane of propagation of the wave.

(*L.U.*, 1932.)

3. Explain what is meant by the terms (a) apparent inductance, (b) capacitance, (c) resistance, and (d) effective height of an aerial. The apparent capacitance, inductance, and resistance of an aerial were found to be $250 \mu\mu\text{F}$., $20 \mu\text{H}$., and 20 ohms respectively at a wavelength of 300 m. A signal of this wavelength and of field strength 5 mV. per m. produced a p.d. of 1 volt across a loading coil of 5 ohms resistance inserted between the aerial and earth and adjusted to tune to the signal. Calculate the effective height of the aerial.

(*I.E.E.*, May, 1932.)

4. Outline the process of calculating approximately the capacitance of a proposed aerial, and describe how to measure this capacitance when the aerial has been erected. What capacitance would you expect to find (a) in a large aerial such as that at Bordeaux or Carnarvon, (b) in a typical aerial for broadcast reception?

(*I.E.E.*, Nov., 1932.)

5. The effective height of a transmitting antenna is 75 m. and it is energized by a current of 20 amperes at 500 kilocycles per sec. A receiving antenna distant 20 miles from the transmitter has an effective height of 10 m., a capacitance of 300 micromicrofarads and negligible inductance. It is tuned to resonance with a series inductance. The total resistance of the receiving antenna and coil circuit is 10 ohms. What is the potential across the coil? Ignore the effects of absorption and assume the inverse-distance law of propagation.

(*I.E.E.*, May, 1933.)

6. A transmitting aerial having an effective height of 120 ft. takes a current of 10 amperes at 1 000 kilocycles. If a receiving aerial with an effective height of 50 ft. and an effective resistance of 4 ohms is erected at a distance of 50 miles from the transmitter, estimate the current in the receiving aerial. State the assumptions made in any formula employed. Explain the formula and each step in the argument. What complications, if any, would be introduced into the calculation if the distance between the transmitting and receiving aeriels were 1 000 miles?

(*L.U.*, 1934.)

7. A transmitting station has an aerial of 100 metres effective height carrying 200 A. at 100 000 c.p.s. A receiving

station 50 miles distant has an aerial of 10 metres effective height which is tuned with a series inductance of 10mH. The resistance of the receiving aerial circuit is 100 ohms. What voltage would appear across the inductance coil?

(*C. & G., Final, 1936.*)

28. FRAME AERIALS

The voltage received in a frame aerial is given approximately by

$$E = (2\pi FAN/\lambda) \cos \theta \text{ volts}$$

where A = frame area in square metres,

F = field strength in volts per metre,

N = number of turns,

λ = wavelength in metres,

θ = angle between the plane of the frame and the direction of propagation.

This applies to loops of all shapes, provided that the loop is small compared with a wavelength.

The exact expression is

$$E = 2FHN \sin [(\pi W/\lambda) \cos \theta]$$

where H = height of frame in metres,

W = width of frame in metres.

If the field strength is given in electromagnetic units it can be transformed to electrostatic units by the relationship
1 gauss (line per sq. cm.) = 300 volts per cm.

The voltage across the tuning capacitance C (microfarads) if the circuit resistance is R is, at resonance,

$$V = \frac{FAN}{300CR} \cos \theta \text{ volts.}$$

EXAMPLES 28

1. A frame aerial has 20 turns of diameter 6 ft., the resistance of the coil being 2.5 ohms at 3 000 m. wavelength. If a

signal of this wavelength has a field strength of 30 microvolts per metre, what current will it produce in the coil when it is tuned to the signal?
(*I.E.E.*, Oct., 1926.)

2. What are the advantages and disadvantages attending the use of frame aerials for reception purposes? In what way can a frame aerial be used as a means of determining the direction of a distant transmitting station?

(*C. & G.*, 1, 1928.)

3. A frame aerial consists of 40 turns; each turn is a square of 1.5 m. side, and the whole has an inductance of 9 000 microhenries. The frame is tuned by a variable condenser. If the frame aerial has a resistance of 8 ohms, what will be the voltage across the condenser when the frame and condenser are tuned to resonance with an incoming field of 20 000 microvolts per metre at a wavelength of 5 000 m.?

(*C. & G.*, *Final*, 1929.)

4. A loop of area 1 sq. m. and having 10 turns has its plane at 45° off the line of bearing of a distant station which produces an incident magnetic field of strength 10^{-9} lines per sq. cm. at a wavelength of 1 000 m. Find the e.m.f. induced in the loop.

(*I.E.E.*, May, 1930.)

5. A rectangular frame 100 cm. long and 50 cm. wide is mounted on an axis with its plane vertical; it is wound with 20 turns of wire. An incident signal has a magnetic field strength of 10^{-8} C.G.S. units and a wavelength of 300 m. Draw to scale a polar diagram of the e.m.f. induced in the loop as it is rotated through a complete revolution.

(*I.E.E.*, Nov., 1932.)

6. A small frame aerial is connected across a calibrated variable condenser. A valve voltmeter is also connected across the condenser. The frame is placed so that its plane is inclined at 45° to the direction of a distant transmitting station sending a continuous dash on 100 000 cycles per sec. Maximum deflection of the voltmeter is obtained when the condenser is adjusted to 1 000 $\mu\mu\text{F}$. The frame is then turned until its plane is in the direction of the transmitting station and the condenser adjusted to give an equal deflection on the valve voltmeter. The capacitance of the condenser is then 990 $\mu\mu\text{F}$. What is the inductance and resistance of the frame aerial circuit?

(*C. & G.*, *Final*, 1933.)

7. A frame aerial consisting of four turns wound on a square of 1 m. side has an inductance of 60 microhenries. It is placed with two of its sides vertical and with its plane in the direction of a transmitting station which gives a field of

10 millivolts per metre at 1 000 kilocycles per sec. If the frame has a resistance of 1 ohm at this frequency and is tuned by a variable condenser of negligible resistance, what will be the voltage across the condenser? Would the result be affected if the frame were placed with a diagonal vertical?

(*I.E.E.*, Nov., 1933.)

8. Find an expression for the voltage induced in a frame aerial by a plane electromagnetic wave, and hence describe the directional properties of the frame aerial. Show how the expression can be simplified if the dimensions of the frame are small compared with the wavelength of the wave.

(*L.U.*, 1934.)

9. Describe a frame aerial. What are the properties which distinguish this type of aerial from a vertical type aerial?

(*C. & G.*, *Prelim.*, 1935.)

10. Explain how and why a frame aerial can be used to indicate the line along which a plane electromagnetic wave is advancing. A rectangular frame aerial having 10 turns is 150 cms. high and 100 cms. wide. The frame is placed with its plane vertical and at an angle of 30° with the direction of propagation of an electromagnetic wave having an electric field strength of 5 mV. per metre at 300 kc. per sec. Assume that the inductance of the frame is $500\mu\text{H.}$, that its resistance is 1.5 ohms and that the circuit is closed by means of a condenser whose capacitance is adjusted for resonance. Calculate the voltage across the terminals of the condenser, and the current through it.

(*L.U.*, 1936.)

11. Explain how a frame aerial can be used for direction finding. A frame aerial consisting of 10 turns, each one metre square, is situated in a field of 10 mV. per metre and wavelength 300 metres. Find the maximum voltage that can be induced in the frame.

(*I.E.E.*, May, 1936.)

12. Explain how a frame aerial is used for direction finding. A frame aerial is set up with its plane in the direction of a transmitting station. When tuned, a hot wire milliammeter in the frame circuit indicates 10 mA. If the frame is rotated through an angle of 45° , what will be the reading on the milliammeter?

(*C. & G.*, *Prelim.*, 1937.)

13. A frame aerial 1 metre high and 1.5 metres wide consists of 16 turns of wire. The frame has a resistance of 10 ohms and an inductance of 800 microhenries. It is tuned to an incoming field of 10 microvolts per metre at a frequency of 300 kc. per second. What will be the voltage across the terminals of the tuning condenser if the plane of the frame is in line with the sending station?

(*C. & G.*, *Inter.*, 1937.)

14. A frame aerial 1 metre high and 1 metre wide consists of 20 turns of wire. The frame has a resistance of 12 ohms and an inductance of 1 mH. It is tuned to an incoming field of $10 \mu\text{V}$. per metre at a frequency of 300 kc/s. What will be the maximum voltage across the terminals of the tuning condenser?
(*I.E.E.*, Nov., 1938.)

15. Find the maximum e.m.f. induced in a frame aerial 2 feet high by 1 foot wide and having 20 turns of wire by a signal of wavelength 800 metres and electric field strength 3 mV. per metre. Prove any formula used. (*L.U.*, 1938.)

16. If a frame aerial of area 2 square metres has 20 turns of wire and its plane is 45° off the line of bearing of a distant transmitting station which produces an incident electric field-strength of 10 mV. per metre at a frequency of 0.5 Mc/s, find the e.m.f. induced in the frame. (*I.E.E.*, May, 1940.)

17. A frame aerial consists of 12 turns having a mean diameter of 60 cm. When the plane of the frame is inclined at an angle of 60° to the direction of propagation of a 300 metre unmodulated wave, the capacitance connected across the frame aerial has to be adjusted to $240 \mu\mu\text{F}$. to give the maximum reading on a valve voltmeter connected across the condenser. When the frame is turned so that its plane is in the direction of propagation, the reading on the voltmeter is limited to the original value of 0.15 volt by increasing the capacitance by $4.7 \mu\mu\text{F}$. Calculate the field strength in volts per metre.
(*L.U.*, 1940.)

18. A frame aerial wound on a square frame of 1 m. side is placed with a diagonal vertical and with its plane directed towards a transmitting station operating on a wavelength of 250 m. The aerial coil consists of 5 turns and has an inductance of $90 \mu\text{H}$. and a resistance at the above wavelength of 1.5 ohms, while the field strength set up by the transmitting station is 10 mV. per metre. If the frame is tuned by a variable condenser of negligible resistance, calculate the voltage developed across this condenser. (*I.E.E.*, May, 1941.)

29. AERIAL TUNING

EXAMPLES 29

1. A receiving aerial has an effective capacitance of 200 micro-microfarads and negligible inductance. In series with it is placed a condenser of 800 micromicrofarads and an inductance

of 250 microhenries. What is the wavelength to which it is tuned? If the condenser is short-circuited, what additional inductance must be added to tune the aerial to 942 m.?

(*C. & G.*, 1, 1928.)

2. An aerial tunes to 450 m. with an inductance of 100⁰ microhenries in series and tunes to 600 m. with an inductance of 200 microhenries in series. What is the capacity and inductance of the aerial?

(*C. & G.*, 1, 1932.)

3. An antenna has a capacitance of 300 $\mu\mu\text{F}$. and an inductance of 30 μH . What series inductance must be added to tune it to a wavelength of 1 500 metres? What alternative method can be used to tune the aerial?

(*C. & G.*, *Prelim.*, 1935.)

4. An antenna has a capacitance of 400 $\mu\mu\text{F}$. and an inductance of 60 μH . What series inductance must be added to tune it to a wavelength of 1 500 metres? What alternative method can be used to tune the aerial? (*I.E.E.*, *Nov.*, 1937.)

5. The equivalent inductance and capacitance of an aerial circuit are measured by means of a transmitting wavemeter. It is found that with a loading inductance of 600 μH . the natural wavelength of the aerial circuit is 400 m., and with a loading inductance of 200 μH . the natural wavelength is 300 m. Calculate the equivalent inductance and capacitance of the aerial.

(*I.E.E.*, *May*, 1939.)

30. DIRECTION FINDING

REFERENCE. *D/F Handbook for Wireless Operators*, by Crook (Pitman); *Wireless Direction Finding*, by Keen (Iliffe & Sons).

EXAMPLES 30

1. A transmitting station which is due west of a small rotatable loop direction finder produces a maximum signal voltage of 0.5 volt. The sensitiveness of the receiver is such that a signal voltage of less than 0.025 volt cannot be perceived by the telephones. Assuming that zero signal does occur when the plane of the loop is north and south, over what range of scale can the pointer be swept without the transmitter becoming audible? (*I.E.E.*, *Nov.*, 1929.)

2. Explain the principle of direction-finding and the cause of night errors. Describe technical details of the application of direction-finding systems to marine use. (*I.E.E.*, *May*, 1930.)

3. Describe any type of directional receiver with its associated aerial system. Explain how it is used to determine the direction of a distant transmitting station.

(*C. & G.*, 1, 1931.)

4. What are the relative advantages of Bellini-Tosi and rotating loop direction-finders? How are these systems used to determine sense? To what errors are these systems liable? Can these errors be overcome? If so, how?

(*C. & G.*, *Final*, 1931.)

5. Explain how an open aerial and a loop can be combined to give a heart-shaped polar diagram for reception.

(*I.E.E.*, *May*, 1931.)

6. Describe a direction-finding system suitable for use on ships. Give sketches showing the arrangement and screening of the coil and discuss the principles involved. Outline the rotating-beacon system used for giving a bearing to ships at sea.

(*I.E.E.*, *May*, 1932.)

7. Describe, with diagrams, a frame aerial suitable for direction-finding on shipboard, and the method of correcting the errors due to the iron work of the ship.

(*I.E.E.*, *Nov.*, 1932.)

8. Describe a method whereby the direction and sense of a distant transmitting station can be determined.

(*I.E.E.*, *May*, 1933.)

9. What are the causes of aberrations, other than instrumental errors, in the direction determinations of Bellini-Tosi and rotating-loop direction-finders at night? What methods have been developed for countering these aberrations?

(*I.E.E.*, *Nov.*, 1933.)

10. What is the cause of night errors in rotating loop and Bellini-Tosi direction finders? Explain clearly how the Adcock aerial tends to obviate such errors. Give diagrams of the aeriels and associated circuits for (a) rotating Adcock system, (b) fixed Adcock system.

(*C. & G.*, *Final*, 1934.)

11. Find an expression for the voltage induced in a square vertical frame aerial as it is rotated about a vertical axis in a plane electromagnetic wave. Explain how direction-finding by wireless is achieved. Discuss briefly the errors which may occur and the methods of minimizing them.

(*I.E.E.*, *Nov.*, 1935.)

12. Give a detailed explanation of the determination of direction and sense of an incoming radio signal by means of a Bellini-Tosi or rotating loop direction finder. What are the relative phases of the resultant voltages impressed on the loop and vertical aerial? Why are bearings sometimes unreliable

(a) at night, and (b) in directions coinciding approximately with a coast-line? (C. & G., *Final*, 1936.)

13. What are the relative advantages of Bellini-Tosi and rotating loop direction finders? State the errors to which these systems are liable. (I.E.E., *Nov.*, 1936.)

14. Describe with sketches the principles of operation of any type of direct-reading direction finder for indicating the direction of arrival of an incoming wave.

(C. & G., *Final*, 1937.)

15. P , Q , R and S are four similar vertical aerials of an Adcock type direction finder. An incoming signal makes a varying angle α with the diagonal PR of the square so formed. Deduce a formula to show that, provided the distance apart of the verticals is small compared with the wavelength, the angular displacement of the rotating coil of the goniometer is a true indication of the value of α . (C. & G., 3, 1940.)

31. AERIAL STRESSES

Unloaded Aerial

The maximum sag or dip at the centre is given by

$$D = wl^2/8T \text{ feet}$$

where l = length of aerial in feet,

w = weight of single wire in lb. per foot,

T = tension at lowest point in lb.

The tension at the support is

$$T_s = T + wD$$

Line Subjected to Wind

If p = wind load in lb. per sq. ft. of projected area of wire, then the wind pressure per foot is

$$P = pd/12 \text{ lb.}$$

where d = diameter of wire in inches.

Total load per foot

$$W = \sqrt{(P^2 + w^2)}$$

Hence, sag

$$= Wl^2/8T \text{ feet}$$

EXAMPLES 31

1. A receiving antenna is erected, comprising a horizontal portion with two parallel wires 6 ft. apart and 80 ft. long, and a

vertical down-lead 60 ft. in length. The weight of the wire used is 0.06 lb. per yd. run. The horizontal portion has a sag at the centre of the span of 5 ft. Calculate the pull in the halyard.
(*I.E.E.*, Oct., 1926.)

2. State the various types of masts and towers used to support the antennæ of land stations. Discuss the relative advantage of stayed masts versus self-supporting towers for various heights of structures.
(*C. & G.*, Final, 1931.)

3. A 1 in. diameter steel wire rope having a safe working load of 10 tons supports an antenna between two masts 1 200 ft. apart. If the weight of the rope is 9 lb. per fathom and the maximum load due to the antenna is 2 lb. per foot of span, what must be the initial sag in the rope if the safe working stress is not to be exceeded under an horizontal wind load of 30 lb. per sq. ft. of projected area of the rope?

(*C. & G.*, Final, 1932.)

4. A steel aerial tower 500 ft. high stands on a square base of 120 ft. side. The weight of the tower, including foundations, is 400 tons. The wind load on the antenna produces a force at the top of the mast normal to the direction of the wind equal to $0.5 v^2$ lb. where v is the velocity of the wind in feet per second. The wind load on the tower itself produces a force in the direction of the wind equal to $1.5 v^2$ lb. at a height of 200 ft. from the ground. The foundation of the tower extends 10 ft. below ground. If the resultant moment due to the above forces is parallel to one of the sides of the square base, what is the velocity of the wind, in miles per hour, which will cause the tower to overturn?

(*C. & G.*, Final, 1933.)

5. Discuss briefly the relative advantages of self-supporting steel towers and stayed masts. Which type is cheaper to construct and erect? What means are adopted to counteract the tendency of steel towers or masts to distort the radiated field due to reflection?

(*C. & G.*, Final, 1935.)

6. A 1-inch diameter steel wire rope having a safe working load of 10 tons, supports an antenna between two masts 1 000 ft. apart. If the maximum load due to the antenna is 2.5 lb. per ft. of span, and the weight of the rope is 1.5 lb. per ft., what must be the initial sag in the rope if the safe working stress is not to be exceeded, under a horizontal wind load of 25 lb. per sq. ft. of projected area of the rope?

(*I.E.E.*, Nov., 1936.)

7. In the last bay of an overhead route there are eight 40-lb. copper conductors. The span is 60 yards and the dip at the centre of the span is 7.36 in. The terminal pole stay is

connected at the point of resultant pull 30 feet from the ground, and has a spread of 10 feet. What is the tension in the stay?

(*I.E.E., May, 1937.*)

8. There is a difference of dip of 1 inch between two wires at the centre of a 60-yard span of 40-lb. cadmium-copper aerial route. The tension in the wire with the lesser dip is 50 lb. What is the tension in the other wire? Calculate the dip of each wire.

(*I.E.E., Nov., 1938.*)

9. The poles of a particular open-wire route carrying 20 copper wires of 150 lb. gauge are 25 ft. in height, have diameters at the top and at ground level of 8 in. and 10 in. respectively, and are spaced 60 yd. apart. If the resulting pull of the wires occurs at 22 ft. above ground level, calculate the bending moment at the foot of the poles due to a transverse wind pressure of 18 lb. per sq. ft. The diameter of 150 lb. gauge copper wire is 0.097 in.

(*I.E.E., Nov., 1940.*)

32. SHORT WAVES

REFERENCE. *Short Wave Wireless Communication*, by Ladner and Stoner; *Short-wave Radio*, by Reyner (Pitman).

EXAMPLES 32

1. Write a brief account of the methods and progress of short-wave telegraphy.

(*I.E.E., Oct., 1927.*)

2. Discuss the possible application of an ultra-short-wave channel of communication, and describe briefly some experiments which have been made with ultra-short waves.

(*I.E.E., Nov., 1932.*)

3. Describe briefly the various devices that have been used to generate alternating currents of wavelength 1 m. or less. Explain what determines the frequency of such oscillations.

(*L.U., 1933.*)

4. Give an account, with circuit diagrams, of the reception of short-wave signals, paying particular attention to the various methods for avoiding self-oscillation of the receiving circuit.

(*I.E.E., Nov., 1934.*)

5. Describe two methods of diversity reception suitable for short-wave telegraphy. Indicate the merits and demerits of each method.

(*C. & G., Final, 1937.*)

6. Describe either a Magnetron or a Klystron valve suitable for generating very short wavelengths. Explain its mode of action.

(*C. & G., 3, 1941.*)

33. PROPAGATION

EXAMPLES 33

1. Explain the causes of fading in the reception of short and medium waves. What methods are adopted in practice to minimize the effects of fading?

(*C. & G., Final, 1933.*)

2. What are the causes of fading? What determines the minimum distance from a transmitting station at which fading is likely to be encountered? How is this distance affected by wavelength and power of the transmitting station?

(*I.E.E., May, 1933.*)

3. How does the propagation of short waves, say below 50 m. wavelength, differ from the propagation of long waves?

(*I.E.E., Nov., 1933.*)

4. What is meant by the term Heaviside layer? How can the height of the layer be determined?

(*I.E.E., Nov., 1933.*)

5. What is the part played by the Heaviside layer in the propagation of short waves? Why is it necessary, in short-wave communication over long distances, to use longer waves during the night than during the day?

(*C. & G., Final, 1934.*)

6. Write a short account of the nature of electromagnetic waves and their propagation round the earth.

(*I.E.E., Nov., 1934.*)

7. What are the causes of fading—

(a) In the case of medium-wave stations within range of the ground ray;

(b) in the case of short-wave stations beyond the range of the ground ray?

What methods are adopted in practice to combat fading?

(*C. & G., Final, 1935.*)

8. Discuss the nature of (a) a plane electromagnetic wave, (b) the electromagnetic wave from a half-dipole (ideal aerial).

(*I.E.E., Nov., 1935.*)

9. What grounds are there for believing in the existence of ionized layers in the upper atmosphere? Describe the methods adopted to determine the heights of such layers.

(*C. & G., Final, 1937.*)

10. Write a short essay on the influence of the ionosphere upon the propagation of electromagnetic waves of various wavelengths ranging from, say, 15 to 3 000 metres.

(*I.U., 1940.*)

34. INTERFERENCE

EXAMPLES 34

1. Give a list of the methods in common use for minimizing the effects of atmospheric and other interference with a short statement of their effectiveness and limits of application.

(*C. & G., Final, 1929.*)

2. What are the methods adopted in practice to reduce the effects of atmospheric and interference in reception (a) in the antenna system, (b) in the receiver?

(*C. & G., Final, 1932.*)

3. Explain why some types of electrical machinery are liable to produce interference with radio reception. How is such interference transmitted? Indicate any method or methods of suppressing interference from small direct current motors.

(*C. & G., Inter., 1934.*)

4. Explain how the interference to radio reception caused by industrial and domestic electrical plant can be prevented or minimized. Give typical methods of suppressing such interference in the case of—

(a) a series d.c. motor,

(b) a shunt d.c. motor,

(c) a universal motor used on a.c. or d.c. circuits,

(d) a neon sign.

(e) an oil-burning equipment of the automatic type.

(*C. & G., Inter., 1936.*)

35. REPRODUCERS AND MICROPHONES

REFERENCES. *Elements of Loud Speaker Practice*, by McLachlan (Oxford Univ. Press); *Telegraphy and Telephony*, by Mallett; *Wireless*, by Turner; *Applied Acoustics*, by Olson and Massa; *Loud Speakers*, by McLachlan.

The force on the moving system is given by

$$F = AI/10 \text{ dynes}$$

where I = current in amperes in the coil,

A = force factor in dynes per ampere.

In the case of a telephone receiver,

$$A = 2BN/R$$

where B = flux density in air gap due to permanent magnet,

N = total turns on both coils,

R = reluctance of magnetic circuit

In the case of a moving-coil speaker,

$$A = Bl$$

where B = mean flux density in the gap,
 l = length of wire on the coil in cm.

The motional impedance is given by

$$z = \frac{A^2 \times 10^{-9}}{r + j(\omega m - s/\omega)} \text{ ohms}$$

where m = mass of moving parts in grams,
 s = stiffness in dynes per cm.,
 r = mechanical resistance in dynes per cm. per sec.

If the suspension in a moving coil speaker exerts a negligible control, $s = 0$, and

$$z = A^2/(r + j\omega m)10^9 \text{ ohms.}$$

If the electrical resistance and inductance of the coil are R and L respectively, the total impedance is

$$R + j\omega L + \frac{10^{-9} \cdot A^2}{r + j(\omega m - s/\omega)}$$

If the coil has a velocity of v cm. per sec., its e.m.f. is

$$E = Av/10^8$$

The displacement of the coil is given by

$$U = v/\omega = v/2\pi f = AI/10\omega r \text{ cm.}$$

The resonant frequency is $f = (1/2\pi)\sqrt{(s/m)}$ c/s.

The decay factor is $\alpha = r/(2m)$.

If R_s is the resistance of a speaker when the cone is stationary and R_f is the resistance when the cone is free, the motional resistance is $R_m = R_f - R_s$, and the efficiency is given approximately by $\eta = R_m/R_f$.

EXAMPLES 35

1. Describe the construction and action of a telephone receiver. What determines the most suitable resistance for the windings of such a receiver in any particular case?

(C. & G., 1, 1929.)

2. Describe the telephone receiver and obtain an expression for its force factor. Why is an ordinary telephone receiver unsuitable for use as a loud-speaker?

(L.U., 1929.)

3. Why does a telephone receiver respond most readily to currents of particular frequencies? Describe any experimental means of determining these frequencies accurately.

(L.U., 1930.)

4. Sketch roughly to scale any form of telephone receiver or loud-speaker. Give some idea of the magnitude of the currents and fluxes in operation. In what way does the motion of the moving part affect the impedance of the instrument? (L.U., 1931.)

5. Describe any microphone suitable for the transmission of broadcast signals and explain, with diagrams, how it is arranged to control the output of the station. (I.E.E., May, 1931.)

6. Describe, with diagrammatic sketches, the principle of a moving-coil loud-speaker, and explain why the alternating motion of the coil may make the input reactance appear to be capacitive. The coil of a certain moving-coil speaker had an inductance of 0.2 H. and was wound with 300 m. of wire and moved in a uniform radial magnetic field. A simple harmonic voltage of constant value and frequency 500 cycles per sec. was applied to the coil. The e.m.f. produced by the movement of the coil could be varied by adjusting the exciting current of the magnet winding. It was found that the current through the coil rose to a maximum value of 10 mA. (r.m.s.) when the strength of the magnetic field was 5 000 lines per sq. cm. Calculate the amplitude of movement of the coil if the control due to the suspension was negligible.

(I.E.E., Nov., 1931.)

7. Compare the different requirements of microphones for service in a telephone installation and in a broadcast studio, and discuss how they are met by the instruments used.

(L.U., 1932.)

8. What is meant by the "motional impedance" of a telephone receiver? Give a theory of the telephone receiver showing how the motional impedance depends upon the electrical and mechanical design.

(L.U., 1933.)

9. Describe the construction of a telephone receiver and explain its action in the production of audible signals. Why is a condenser sometimes connected across a telephone, and when is the use of such a condenser advisable?

(C. & G., 1, 1933.)

10. What is meant by the motional impedance of a telephone receiver? Explain how it would be measured and how the total impedance of the receiver would vary with frequency.

(I.E.E., May, 1934.)

11. Describe with sketches the construction of a modern form of moving-coil loud-speaker. Explain the action, and find a formula from which the pull on the coil can be calculated.

(I.E.E., May, 1934.)

12. Compare and contrast the different duties of a telephone

receiver and a loud-speaker. A telephone receiver has 680 turns on each pole of the permanent magnet, which gives a flux density in the air gap of 900 lines per sq. cm. The reluctance of the magnetic circuit to alternating fluxes is 0.6 c.g.s. units. A moving-coil loud-speaker has a coil of 1 100 turns and diameter 2.5 cm. in a field of 1 400 lines per sq. cm. If the loud-speaker were fitted with a diaphragm identical with that of the telephone receiver, what would be the ratio of the currents required to give the same amplitude of vibration in the two cases? (L.U., 1934.)

13. The impedance of a telephone receiver is measured in a bridge in which the arms adjacent to the receiver have resistances of 1 000 ohms and 800 ohms respectively, and the arm opposite the receiver has at balance a resistance of 8 000 ohms in parallel with a capacitance of 0.2 microfarad. Find the resistance and inductance of the receiver, proving any formula used. (I.E.E., Nov., 1934.)

14. Why is it desirable to use a permanent magnet in the ordinary telephone receiver? What happens if the permanent magnet of a telephone receiver is replaced by a soft iron core? (C. & G., Prelim., 1936.)

15. Describe a method of ascertaining the effective mass and the effective stiffness of a telephone receiver diaphragm. The effective mass of such a diaphragm, when assembled in a receiver, is 1.4 grammes, and the effective stiffness is 54×10^6 dynes per cm. Calculate the principal resonance frequency of the receiver. Explain why, and in what manner, the response curve of a receiver when held to the ear differs from that representing sound reproduction into free space. (L.U., 1936.)

16. Write a theory of the action of a telephone receiver. If a current of 2.0 mA. through a receiver produces, at the resonant frequency of 1 000 c/s, a vibration amplitude at the centre of the diaphragm of 0.008 mm., and if the motional impedance at this frequency is 160 ohms and the decay factor is 120, find the force factor of the receiver and the equivalent mechanical constants of the diaphragm. (L.U., 1938.)

17. Explain the operation of a moving-coil loud speaker, drawing diagrams to show (a) the magnetic circuit of the instrument, clearly indicating the direction of the magnetic flux, (b) the method of support of the cone and the attachment of the moving coil. (C. & G., 1, 1939.)

18. Describe tests that should be carried out on a loud speaker to determine its suitability for use in a broadcast receiver. (L.U., 1940.)

36. FILTERS AND ATTENUATORS

REFERENCES. *Theory of Electrical Artificial Lines and Filters*, by Bartlett (Chapman & Hall); *Electric Circuits and Wave Filters*, by Starr (Pitman); *Telegraphy and Telephony*, by Mallett; *Wireless*, by Turner.

Filters

Let x be the series impedance and y the shunt impedance, and let g be the positive value of $1 + x/2y$.

Then the attenuation constant is given by

$$\begin{aligned} \alpha &= \cosh^{-1} g \\ &= \log_h [g + \sqrt{(g^2 - 1)}] \end{aligned}$$

The attenuation

$$\begin{aligned} &= \alpha \text{ nepers} \\ &= 8.686\alpha \text{ decibels.} \end{aligned}$$

Recurrent Networks

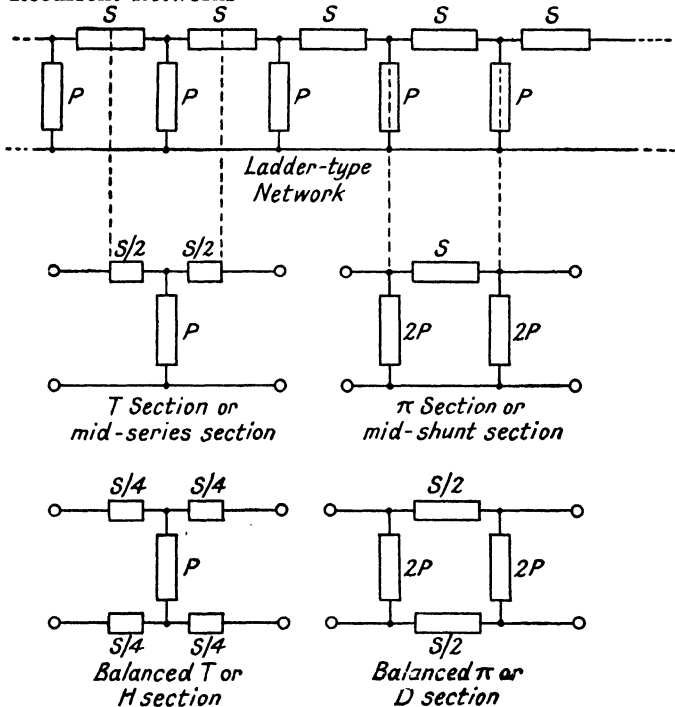
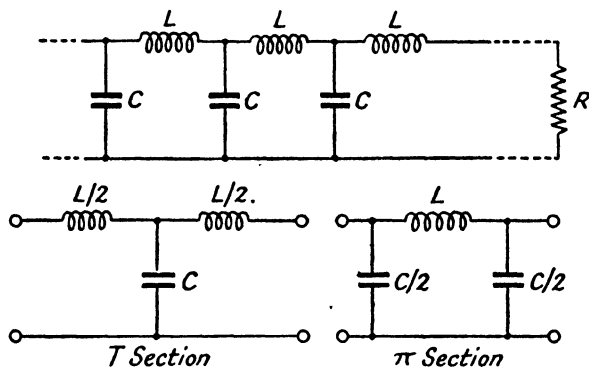

FIG. 8

Low-pass Filter

FIG. 9. CONSTANT- k TYPE

$$L = 2R/\omega$$

$$\omega = 2/\sqrt{LC}$$

$$C = L/R^2$$

$$R = \sqrt{L/C}$$

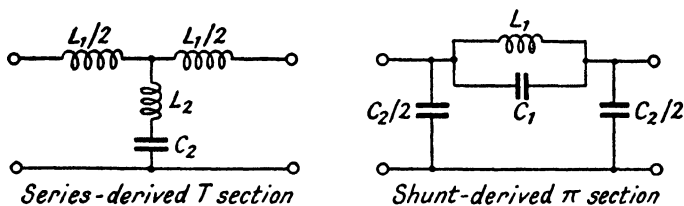

FIG. 10. DERIVED TYPE

$$L_1 = mL$$

$$L_2 = AL$$

$$C_1 = L_2/R^2$$

$$C_2 = L_1/R^2$$

where $m = \sqrt{1 - (f/F)^2}$, $A = (1 - m^2)/4m$, f is the cut-off frequency, and F is the frequency of maximum attenuation.

High-pass Filter

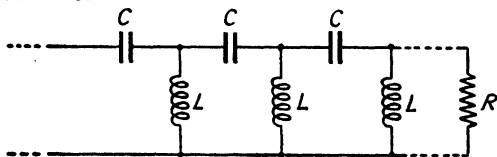

High-pass Filter. Constant- k type

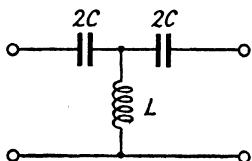

T Section

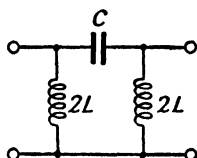

π Section

FIG. 11. CONSTANT- k TYPE

$$L = R/2\omega$$

$$C = L/R^2$$

$$\omega = 1/2\sqrt{LC}$$

$$R = \sqrt{L/C}$$

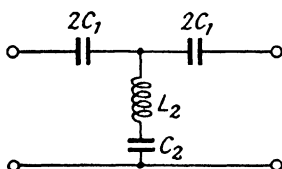

Series-derived T section

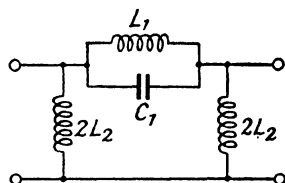

Shunt-derived π section

FIG. 12. DERIVED TYPE

$$L_1 = L/A$$

$$C_1 = L_2/R^2$$

$$L_2 = L/m$$

$$C_2 = L_1/R^2$$

where $m = \sqrt{1 - (F/f)^2}$, $A = (1 - m^2)/4m$

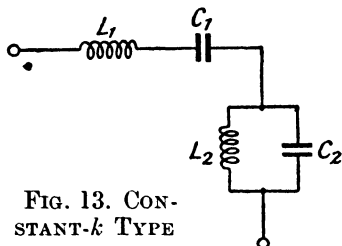
Band-pass FilterFIG. 13. CONSTANT- k TYPE

$$L_1 = 2R/(\omega_1 - \omega_2)$$

$$C_1 = L_2/R^2$$

$$L_2 = (\omega_1 - \omega_2)R/2\omega_1\omega_2$$

$$C_2 = L_1/R^2$$

Band-elimination Filter

$$L_1 = 2R(\omega_1 - \omega_2)/\omega_1\omega_2$$

$$C_1 = L_2/R^2$$

$$L_2 = R/2(\omega_1 - \omega_2)$$

$$C_2 = L_1/R^2$$

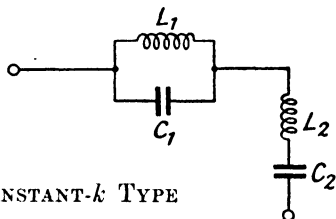
FIG. 14. CONSTANT- k TYPE**Attenuators**

T type. The series resistances A and B and the shunt resistance C to produce a loss of D decibels between resistances P and Q respectively are given by

$$C = [2\sqrt{(PQN)}]/(N - 1)$$

$$A + C = P(N + 1)/(N - 1)$$

$$B + C = Q(N + 1)/(N - 1)$$

where

$$D/10 = \log N$$

$$\text{If } P = Q, \quad C = (2P\sqrt{N})/(N - 1)$$

$$\text{and } A = B = P(\sqrt{N} - 1)/(\sqrt{N} + 1)$$

Π type. The series resistance C and the shunt resistances A and B to produce a loss of D decibels between resistances P and Q respectively are given by

$$C = \frac{1}{2}(N - 1)\sqrt{(PQ/N)}$$

$$1/A + 1/C = (N + 1)/P(N - 1)$$

$$1/B + 1/C = (N + 1)/Q(N - 1)$$

$$\text{If } P = Q, \quad C = P(N - 1)/2\sqrt{N}$$

$$\text{and } A = B = P(\sqrt{N} + 1)/(\sqrt{N} - 1)$$

EXAMPLES 36

1. Give circuit diagrams of the following, and show by sketches the approximate magnitude of the attenuation produced in the various ranges.

(a) A low-pass filter; (b) a high-pass filter; (c) a band-elimination filter; (d) a band-pass filter. (*I.E.E.*, Oct., 1926.)

2. Give circuit diagrams of a low-pass filter, a high-pass filter, and a band-pass filter, and explain their various uses.

(*I.E.E.*, Oct., 1927.)

3. Draw a diagram of (a) a low-pass, (b) a high-pass, and (c) a band-pass filter circuit, and explain the action of each type. Illustrate your explanation with a numerical example for a filter of one type.

(*I.E.E.*, May, 1930.)

4. Give an example of (1) a low-pass filter; (2) a high-pass filter, and (3) a band-pass filter, and find expressions for their cut-off frequencies.

(*L.U.*, 1931.)

5. What is a wave filter? Give typical characteristic curves indicating the attenuation in respect to frequency in the case of high-pass, low-pass, and band-pass filters. How does the ratio of series impedance Z_1 to shunt impedance Z_2 in a filter determine its attenuation in respect to frequency?

(*C. & G.*, Final, 1934.)

6. A chain circuit consists of a number of T links having in each half of the horizontal part an inductance $L/2$ and resistance $R/2$, and in the vertical part a capacitance C . Explain how the transmission properties of the circuit vary with frequency, and find expressions for the propagation constant and the cut-off frequency.

(*I.E.E.*, May, 1934.)

7. An attenuator of T-type is required to produce a loss of 10 decibels in a 600 ohm transmission line. Compute the values of the shunt and series resistances.

(*C. & G.*, Final, 1934.)

8. Define the terms (a) decibel, and (b) neper. An attenuator inserted in a transmission line produces a loss of 60 decibels; what is this loss in nepers?

(*C. & G.*, Inter., 1935.)

9. It is desired to insert a T-type low-pass filter having a cut-off of 3 000 cycles in a line of 600 ohms characteristic impedance. Compute the values of the series and shunt elements of a suitable filter section, assuming non-dissipative elements.

(*C. & G.*, Final, 1935.)

10. Compute the values of the series and shunt elements of an H-type attenuator having a characteristic impedance of 600 ohms and a loss of 40 db.

(*C. & G.*, Inter., 1936.)

11. What is meant by a wave filter of (a) the constant- k type, (b) the derived type? A high-pass filter for 600 ohms

terminations is required to cut off below 20 000 c.p.s. Compute the values of the shunt and series elements.

(*C. & G., Final, 1936.*)

12. What are the requirements for an inductance coil intended to be used in a filter circuit? How are the requirements met in modern practice? A simple three-stage, high-pass filter is to be inserted in a transmission line which has a characteristic impedance of $600 \Omega / 0^\circ$. The cut-off frequency is 500 c.p.s. Calculate the inductances of the coils and the capacitances of the condensers required. (*L.U., 1936.*)

13. What is the effect of resistance in modifying the performance of wave filters? What are the conditions determining the transmitting ranges and attenuating ranges of a wave filter? A single T-network having $Z_1/2$ as the value of each series impedance, and Z_2 as the value of the shunt impedance, is terminated with an impedance Z_k . It is required that the input impedance must also be Z_k . Find Z_k in terms of Z_1 and Z_2 . (*C. & G., Final, 1937.*)

14. Calculate the values of a three-element low-pass constant- k filter having a cut-off frequency of 1 000 cycles per second and a terminal impedance of 600 ohms, using (a) a T-section and (b) a Π -section.

15. Design a constant- k low-pass filter to have a cut-off frequency of 796 cycles per second and a terminal impedance of 600 ohms, using (a) a T-section and (b) a Π -section.

16. Design an m -derived low-pass filter to have the same characteristics as that of the filter in the preceding question, using (a) a T-section and (b) a Π -section. Take m to be 0.6.

17. Design a composite low-pass filter having the same constants as in the preceding questions and comprising one simple section and one derived section, using (a) mid-series sections and (b) mid-shunt sections.

18. Calculate the values of a three-element high-pass constant- k filter having a cut-off frequency of 2 000 cycles per second and a terminal impedance of 600 ohms, using (a) a T-section and (b) a Π -section.

19. Design a constant- k high-pass filter to have a cut-off frequency of 796 cycles per second and a terminal impedance of 600 ohms, using (a) a T-section and (b) a Π -section.

20. Design an m -derived high-pass filter to have the characteristics of the filter in the preceding question, using (a) a T-section and (b) a Π -section. Take m to be 0.6.

21. Design a composite high-pass filter having the same constants as in the preceding questions and comprising one

simple and one derived section, using (a) mid-series sections and (b) mid-shunt sections.

22. A constant- k band-pass filter terminated by 600 ohms has a lower cut-off frequency of 120 kc/s and an upper cut-off frequency of 123 kc/s. Calculate the values of the elements for (a) a T-section and (b) a Π -section.

23. A constant- k band-elimination filter is required to suppress frequencies between 1 000 and 1 800 cycles per second, and to have a terminal impedance of 500 ohms. Calculate the values of the elements of (a) a T-section and (b) a Π -section.

24. A symmetrical filter section of the T-type has series inductances of 100 mH. and a shunt capacitance of 1 μ F. Determine the cut-off frequency of the filter. Prove any formula employed. (I.E.E., Nov., 1939.)

25. In a T-type attenuator designed to work into a load of 600 ohms, each series resistance is 400 ohms. Compute the attenuation.

26. In a π -type attenuator designed to operate into a load of 600 ohms, each shunt resistance is 1 000 ohms. Calculate the attenuation.

27. In an H-type attenuator matched to a transmission line of 600 ohms impedance, each of the series resistances is 240 ohms. Calculate the attenuation. Determine, also, the value of the shunt resistance.

28. Calculate the values of the series and shunt elements of a π -type attenuator having a characteristic impedance of 600 ohms and a loss of 20 decibels. (I.E.E., May, 1938.)

29. Draw the circuit diagram of a symmetrical H-section resistance attenuator. Derive formulae for such an attenuator and calculate the component resistances of a 20 decibel section of 600 ohms characteristic impedance. (I.E.E., Nov., 1938.)

30. An attenuator of the T-type is required to give a loss of 20 db. in a transmission line having a characteristic impedance of 1 200 ohms. Calculate the values of the shunt and series resistances of the attenuator. (I.E.E., May, 1939.)

31. Define the transmission units "decibel" and "neper." Show that a symmetrical T-section of pure resistances whose attenuation is $20 \log A$ decibels has series resistances each equal to $R(A - 1)/(A + 1)$ and shunt resistance $2AR/(A^2 - 1)$, where R is the iterative resistance of the network.

(I.E.E., Nov., 1940.)

37. POWER SUPPLIES

REFERENCES. *Modern Radio Communication*, by Reyner; *Admiralty Handbook of Wireless Telegraphy*.

EXAMPLES 37

1. Give a circuit diagram of a three-phase full-wave thermionic rectifier, using cooled anode valves suitable for furnishing high-tension direct current to a high-power valve transmitter. The anodes of the rectifier valves are to be worked at earth potential. Smoothing circuits are to be shown suitable for supplying the penultimate and final stages of the transmitter. The output of the rectifier is 200 kW. and the efficiency 85 per cent. What will be the current taken from the supply mains at a power-factor of 0.8 if the voltage of supply between phases is 400? (C. & G., Final, 1933.)

2. Describe fully how the necessary direct current for a large wireless transmitting station is obtained from a three-phase low-tension supply. (I.E.E., May, 1935.)

3. The power supply to a transmitting station is 11 000 volts, 50 c/s, three-phase. The short-wave transmitters, having a maximum output of about 60 kW., require an anode voltage not greater than 6 500 volts. Give an outline of the design of the power equipment. (C. & G., 3, 1940.)

38. TRANSMISSION LINES

REFERENCE. *Telegraphy and Telephony*, by Mallett.

The characteristic impedance of a line is

$$Z = \sqrt{\left[\frac{R + j\omega L}{G + j\omega C} \right]}$$

where R , L , C and G represent the resistance (ohms), inductance (henries), capacitance (farads) and conductance (mhos) respectively per unit length of line.

For high frequency currents, R and G become negligible in comparison with ωL and ωC and

$$Z = \sqrt{L/C},$$

its angle being zero.

If the characteristic resistance of a line is Z and the resistance of the load R , the reflection ratio is

$$4r/(1 + r)^2$$

where $r = R/Z$. The reflection loss is

$$10 \log [(Z+R)^2/4ZR] = 20 \log [(Z+R)/2\sqrt{ZR}] \text{ decibels}$$

Twin and Concentric Lines

The characteristic impedance of a parallel-wire air line is

$$Z = 276 \log (S/r) \text{ ohms}$$

where S is the spacing and r is the radius of the conductors expressed in the same units.

This usually lies between 400 and 800 ohms for practical values of the ratio S/r .

The characteristic impedance of a concentric line is

$$Z = 138 \log (R/r) \text{ ohms,}$$

where R is the inner radius of the outer conductor and r is the outer radius of the inner conductor.

This usually lies between 50 and 150 ohms for practical values of the ratio R/r .

If the conductors are separated by a dielectric of permittivity κ , the characteristic impedance is

$$Z = (138/\sqrt{\kappa}) \log (R/r) \text{ ohms.}$$

Quarter-Wave Lines

The impedance Z_1 measured at one end of a quarter-wave line which is terminated at the other by an impedance Z_2 is

$$Z_1 = Z_0^2/Z_2$$

where Z_0 is the characteristic impedance of the line.

In other words, a quarter-wave line matches two impedances Z_1 and Z_2 connected to its extremities if

$$Z_0 = \sqrt{(Z_1 Z_2)}.$$

EXAMPLES 38

1. The attenuation of energy in a carrier transmission line is stated to be 16 transmission units. Assuming the line to be properly terminated without reflections, what is the ratio of the voltages at the two ends of the circuit?

(*I.E.E.*, Oct., 1926.)

2. A high-frequency transmission line consists of a pair of open wires having an inductance of 0.004 henry per mile and

a capacitance of 0.01 microfarad per mile. What is its characteristic impedance? If the line is connected to an antenna whose input impedance is $80\sqrt{0}$ ohms, what will be the loss due to reflection? How can this loss be reduced?

(*I.E.E.*, May, 1933.)

3. Explain with a schematic diagram the working of a simple type of radio telephone link between two land line networks. Can such a system be worked on the same wavelength in both directions? What are the limitations of such a system?

(*C. & G.*, *Inter.*, 1934.)

4. Find the characteristic impedance of a telephone loop having a resistance of 10 ohms, an inductance of 12 mH., a capacitance of $0.010 \mu\text{F.}$, and a leakance of 10^{-5} mho, all per loop mile.

(*I.E.E.*, Nov., 1934.)

5. A high-frequency transmission line consists of a pair of open wires having a distributed capacitance of $0.01 \mu\text{F.}$ per mile and a distributed inductance of 3 mH. per mile. What is the characteristic impedance of this line? Describe a suitable method for connecting this line to an aerial having an impedance of 100 ohms.

(*C. & G.*, *Final*, 1935.)

6. Describe, with a diagram, the apparatus necessary for the connection of a long distance radio-telephone link to the public telephone system. Why is it necessary to use a singing suppressor in such circuits? Describe a thermionic or electro-mechanical type of singing suppressor.

(*C. & G.*, *Final*, 1935.)

7. Describe the method used to connect a radio-telephone link to a trunk telephone circuit where active stabilizing devices are not used. What are the limits imposed in such circuits to the maximum amplification which can be employed?

(*C. & G.*, *Inter.*, 1936.)

8. An antenna array presents an impedance of 3 000 ohms to the transmitting line feeding it, which consists of two 0.10 in. diameter copper wires, 9 in. apart. Calculate the dimensions of a suitable matching system between the antenna and the feeder.

(*C. & G.*, *Final*, 1936.)

9. In a communication channel involving both wireless and land line, describe the circuit arrangements necessary at the junction of the two.

(*I.E.E.*, May, 1936.)

10. A high-frequency open-wire transmission line has a distributed capacitance of 0.02 microfarad per mile and a distributed inductance of 7.2 mH. per mile. What is the characteristic impedance of the line? Find suitable dimensions of a quarter-wave matching line to match this transmission line to a load of 200 ohms.

(*C. & G.*, *Final*, 1937.)

11. A beam aerial is connected to a two-wire open transmission line. If the aerial at the junction of the transmission line has a resistance of 1 200 ohms, and the ratio of the distance between wires to the diameter of each wire is 50, design a device to match the aerial to the transmission line. If the device could not conveniently be located adjacent to the aerial, where would you place it?
(*C. & G.*, 3, 1938.)

12. A high-frequency open-wire transmission line has a distributed capacitance of 0.03 μ F. per mile and a distributed inductance of 10.8 mH. per mile. Calculate the characteristic impedance of the line. Find suitable dimensions of a quarter-wave matching line to match this transmission line to a load of 300 ohms.
(*I.E.E.*, Nov., 1938.)

13. A highly insulated coaxial cable is used as a radio-frequency transmission line. If the inner conductor has a diameter of $\frac{1}{8}$ in. and the outer conductor an inside diameter of $\frac{1}{2}$ in., determine the characteristic impedance of the cable. Assume that the spacer between the conductors has a permittivity of unity.
(*I.E.E.*, May, 1939.)

14. Deduce an expression for the input impedance of a quarter-wavelength transmission line operating at radio frequency and terminated by a given impedance. Explain the significance of the result obtained when the far end of the line is (a) open-circuited, (b) short-circuited. Calculate the input impedance of a quarter-wavelength line operating at radio frequency, having a characteristic impedance of $90 \sqrt{0^\circ}$ ohms and terminated by an impedance of $81 \sqrt{30^\circ}$ ohms.

(*I.E.E.*, Nov., 1939.)

15. The central conductor of a concentric cable feeding an aerial array has a diameter of $\frac{1}{16}$ in. and the outer conductor an inside diameter of $\frac{3}{8}$ in. If the permittivity of the low-loss dielectric which separates the conductors continuously along their length is 2.2, calculate the characteristic impedance of the cable. Describe, and explain the principle of, one method by which a feeder may be "matched" to an aerial system of different impedance.
(*I.E.E.*, Nov., 1940.)

39. MEASUREMENTS

REFERENCES. *Radio Frequency Measurements*, by Moullin; *High Frequency Measurements*, by Hund; *Measurements in Radio Engineering*, by Terman; *Radio Frequency Electrical Measurements*, by Brown; *A.C. Measurements*, by Owen; *Radio Frequency Measurements*, by Hartshorn.

Inductance

Self-inductance by resonance method ;

$$L = 25\,330/f^2C \text{ microhenries}$$

where

$$f = \text{frequency in Mc/s,}$$

$$C = \text{capacitance in } \mu\mu\text{F.}$$

Effect of self-capacitance ;

$$\text{Apparent inductance } L_s \doteq L/(1 - \omega^2LC)$$

$$\doteq L(1 + \omega^2LC)$$

where

$$L = \text{true inductance of coil,}$$

$$C = \text{self-capacitance of coil.}$$

Apparent mutual inductance between two coils ;

$$M_s = M[1 + \omega^2(L_1C_1 + L_2C_2)]$$

where

$$M = \text{true mutual inductance,}$$

$$L_1, L_2 = \text{inductances of the coils,}$$

$$C_1, C_2 = \text{self-capacitances of the coils.}$$

Capacitance

Self-capacitance of a coil ;

$$C = (f_1^2C_1 - f_2^2C_2)/(f_2^2 - f_1^2)\mu\mu\text{F.}$$

where $C_1 =$ tuning capacitance in $\mu\mu\text{F.}$ at frequency f_1 ,

$C_2 =$ tuning capacitance in $\mu\mu\text{F.}$ at frequency f_2 .

Using the harmonic method, i.e. when $f_2 = 2f_1$

$$C = \frac{1}{3}(C_1 - 4C_2).$$

Measurement of very small capacitance by the heterodyne method ;

$$c = 2fC/F.$$

where $C =$ oscillator capacitance,

$F =$ frequency at which the test is made,

$f =$ change in beat frequency having due regard to sign.

Resistance

By the capacitance variation method ;

$$R = (C_1 - C_2)I_1/2\omega C_1C_2\sqrt{(I_0^2 - I_1^2)}$$

where I_0 = induced current at resonance,

I_1 = induced current at capacitances C_1 and C_2 on either side of resonance.

If $I_0 = I_1\sqrt{2}$, $R = (C_1 - C_2)/2\omega C_1 C_2$

By the frequency variation method ;

$$R = L(\omega_1 - \omega_2)/\sqrt{\{(E_0/E_1)^2 - 1\}}$$

where L = the inductance of the circuit,

E_0 = condenser voltage at resonance,

E_1 = condenser voltage at pulsatances ω_1 and ω_2 on either side of resonance.

If $E_0 = E_1\sqrt{2}$, $R = L(\omega_1 - \omega_2)$.

EXAMPLES 39

1. Explain how an attenuator can be used in connection with a radio frequency oscillator and an audio frequency oscillator for measuring the amplification, selectivity and fidelity of broadcast receivers. (*C. & G., Inter., 1934.*)

2. Describe any method of measuring the field strength due to a distant transmitting station. What approximately is the minimum field strength that can be measured by normal equipment? (*C. & G., Inter., 1936.*)

3. Determine an expression which gives the effective inductance at any frequency of a coil of known self-capacitance. If the self-capacitance of a coil is $8 \mu\mu\text{F}$. and its low-frequency inductance is $100 \mu\text{H}$., calculate its effective inductance (a) at 0.8 Mc/s , (b) at 1.6 Mc/s .

4. Two coils, of inductances $50 \mu\text{H}$. and $200 \mu\text{H}$. respectively, are magnetically coupled. Determine the effective value, at a frequency of 2 Mc/s , of the mutual inductance between them if their self-capacitances are 5 and $7 \mu\mu\text{F}$. respectively and the coupling coefficient is 0.05 . Prove the formula used. Neglect the effect of mutual capacitance between the coils.

5. An oscillator is tuned by a standard capacitor of $730 \mu\mu\text{F}$. to oscillate at 1 Mc/s : a heterodyne oscillator is tuned to a frequency a little below the first to produce a beat note of 3 kc/s in a receiver which is coupled to both. On connecting a small capacitor in parallel with the standard, the beat frequency falls to 1.8 kc/s and increases with increase of the heterodyne oscillator frequency. Compute the value of the added capacitance and prove the formula used.

6. An oscillator, tuned by a standard capacitor of $500 \mu\mu\text{F.}$, operates at 2 Mc/s: a heterodyne oscillator, tuned to a frequency a little below the first, produces a beat note of 3 kc/s in a receiver which is coupled to both. On connecting a small capacitor in parallel with the standard, the beat frequency falls to 400 c/s and decreases with increase of the heterodyne oscillator frequency. Calculate the value of the added capacitance.

7. A coil, tuned by a capacitance C , is loosely coupled to a high-frequency oscillator. The values of C to produce resonance at 1 Mc/s and 1.5 Mc/s are 794 and $350 \mu\mu\text{F.}$ respectively. Determine the inductance and self-capacitance of the coil.

8. A coil is tuned to a frequency of 700 kc/s by a capacitance of $250 \mu\mu\text{F.}$: to tune the coil to the second harmonic of this frequency a capacitance of $55 \mu\mu\text{F.}$ is required. Calculate the self-capacitance of the coil.

9. A coil tuned by a condenser C is loosely coupled to a high-frequency generator. The values of C to produce resonance at 1 Mc/s and 1.4 Mc/s are 800 and $400 \mu\mu\text{F.}$ respectively. Find the self-capacitance of the coil.

(*I.E.E., May, 1938.*)

10. The voltage across an oscillatory circuit of inductance 1 mH. when loosely coupled to a high-frequency oscillator and tuned to resonance is 4 V.: this decreases to 1.4 V. when the oscillator frequency is adjusted to 255 kc/s and to 247 kc/s for the same oscillator current. Compute the high-frequency resistance of the circuit.

11. In the measurement of the resistance of a circuit at 200 kc/s by the capacitance variation method, the two values of capacitance necessary to give a secondary current of half the resonant value were 471 and $495 \mu\mu\text{F.}$ respectively. Calculate the resistance of the circuit at this frequency.

12. An oscillatory voltage of frequency 700 kc/s is introduced across a resistance of 0.2 ohm in series with a $100 \mu\text{H.}$ coil and a condenser tuned to this frequency: the "Q" of the circuit is found to be 120. Determine the h.f. resistance of the coil if the series resistance of the condenser is negligible.

13. In order to measure the resistance of a coil of negligible self-capacitance it is connected in series with a thermo-milliammeter of 9 ohms resistance across a variable condenser. The circuit is then weakly coupled to a high-frequency source of 1 Mc/s. When the condenser is tuned to resonance, a current of 10 mA. flows in the circuit. The condenser is then adjusted above and below the resonance

frequency, until the current is 7.07 mA. The values of the condenser to give this current are 450 and 650 $\mu\mu\text{F.}$, respectively. What is the resistance of the coil?

(*C. & G.*, 2, 1937.)

14. A coil of negligible self-capacitance is connected in series with a thermo-milliammeter of 8 ohms heater resistance across a variable condenser. The circuit is then loosely coupled to an h.f. source of 1 Mc/s. A current of 10 mA. flows in the circuit when the condenser is tuned to resonance. The condenser is then adjusted above and below the resonance frequency until the current is 7.07 mA. The values of the condenser to give this current are 400 and 600 $\mu\mu\text{F.}$, respectively. Calculate the resistance of the coil. (*I.E.E.*, Nov., 1938.)

15. Describe one method of measuring the field strength due to a local medium-wave broadcasting station. State the approximate values of field strength that you would expect.

(*C. & G.*, 2, 1940.)

40. MEASURING INSTRUMENTS

REFERENCE. *Radio Frequency Measurements*, by Moullin

EXAMPLES 40

1. Describe with diagrams one type of field strength measuring set. What precautions are necessary in the construction of such a set? State how the set is used to measure fields.

(*C. & G.*, *Final*, 1931.)

2. Describe some circuit arrangements suitable for a valve voltmeter and discuss for each the dependance of the calibration on frequency and on wave-form. (*I.E.E.*, May, 1932.)

3. Describe with a diagram a valve voltmeter suitable for the measurement of high-frequency potential differences of the order of 0.1 volt. How would you calibrate such an instrument?

(*I.E.E.*, Nov., 1933.)

4. Describe a valve-wattmeter method of measuring powers of telephonic frequency and magnitude. (*I.E.E.*, May, 1934.)

5. Describe two types of ammeters suitable for measuring high-frequency currents of the order of 10 amperes. Mention any characteristics of these instruments. How do they behave when supplied with direct current or low-frequency alternating current? What would be the scale reading when the meter was supplied with 5 amperes r.m.s. of high-frequency current superimposed on 5 amperes of direct current?

(*C. & G.*, *Inter.*, 1935.)

41. A.C. BRIDGES

REFERENCES. *Alternating Current Bridge Methods*, by Hague (Pitman).

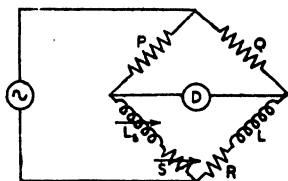
**Maxwell Inductance Bridge**

$$L = \frac{QL}{P}$$

$$R = \frac{QS}{P}$$

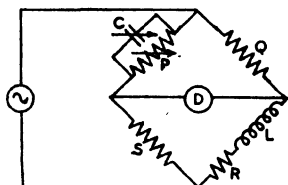
**Maxwell L/C Bridge**

$$L = CQS$$

$$R = \frac{QS}{P}$$

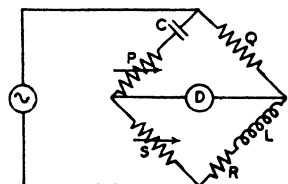
**Hay Bridge**

$$L = \frac{CQS}{1 + (\omega CP)^2}$$

$$R = \frac{PQS (\omega C)^2}{1 + (\omega CP)^2}$$

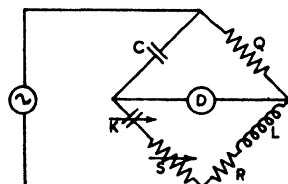
**Owen Bridge**

$$L = CQS$$

$$R = \frac{CQ}{K}$$

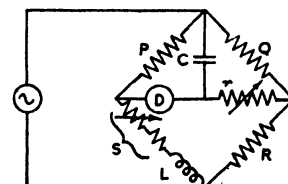
**Anderson Bridge**

$$L = CP \left(R + r + \frac{rR}{Q} \right) -$$

$$S = \frac{PR}{Q}$$

FIG. 15

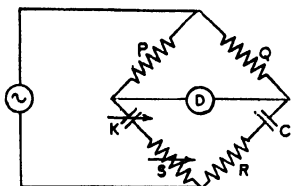

Series-resistance Capacitance Bridge

$$C = \frac{KP}{Q} \quad R = \frac{QS}{P}$$

Parallel-resistance Bridge.
The same formulae are applicable if R and S are in parallel with C and K respectively.

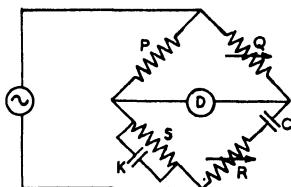

Wien Bridge

$$K = C \left(\frac{Q}{P} - \frac{R}{S} \right)$$

$$C\dot{K} = \frac{1}{\omega^2 RS}$$

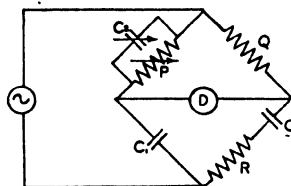

Schering Bridge

$$C = \frac{C_1 P}{Q}$$

$$R = \frac{C_2 Q}{C_1}$$

Power factor = $\omega C_2 P$

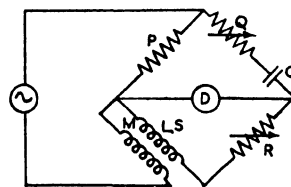

Carey Foster Bridge

$$M = CP(R + S)$$

$$L = M \left(1 + \frac{Q}{P} \right)$$

Heaviside-Campbell Equal-ratio Bridge

If $P = Q$

$$L = 2(M - m)$$

$$R = S - s$$

where m, s are the readings obtained with L, R short-circuited.

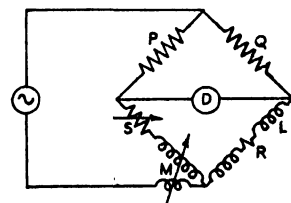

FIG. 16

EXAMPLES 41

1. In a Hay bridge, one arm consists of a $1 \mu\text{F}$. capacitor in series with a resistance of 32 ohms. The two adjacent arms contain resistances of 597 and 37 ohms respectively. Calculate the inductance and effective resistance of the coil if the pulsance used is 5 000. Prove any formula used.

2. In a Maxwell bridge the resistance in two opposite arms are 2 000 and 750 ohms respectively. The third arm consists of a capacitance of 0.05 microfarad in parallel with a resistance of 40 000 ohms. Deduce the conditions for balancing this bridge and calculate the inductance and resistance of the coil under test.

3. A Schering bridge, used to test a condenser, comprises a standard capacitor of 0.05 microfarad, a non-inductive resistance of 20 000 ohms in the opposite arm, and a third arm consisting of a capacitance of 300 micromicrofarads in parallel with a non-inductive resistance of 1 200 ohms. Calculate the capacitance and power factor of the condenser at a frequency of 1 kc/s.

4. In an Anderson bridge for the measurement of the inductance of a coil, the three resistive arms of the bridge are 100, 100, and 1 000 ohms respectively. A capacitance of 0.2 microfarad is connected to the junction of the two latter and a resistance of 210 ohms to the junction of the two former. Calculate the inductance of the coil and prove the formula used.

5. In an Owen bridge, each capacitance is 0.2 microfarad and the resistance in series with one of them is 2 047 ohms; in the arm opposite to the latter is a resistance of 100 ohms while the remaining arm comprises a resistance of 89 ohms in series with the coil under test. Calculate the inductance and resistance of the coil and prove the formulae used.

6. In a Wien bridge, the ratio arms consist of resistances of 200 and 100 ohms respectively. Opposite to the latter is a capacitance of 0.01 microfarad in series with a resistance of 100 ohms. If the frequency of the bridge is 796 c/s, calculate the capacitance and shunt resistance of the capacitor forming the fourth arm. Prove any formula used.

7. In a Carey Foster bridge used for measuring the mutual inductance between two coils, a fixed capacitance of 0.35 microfarad is used. With a standard resistance P of 100 ohms in the primary circuit, the resistance R in series with the secondary is 440 ohms to secure balance, while if P is 200 ohms R is found to be 200 ohms. Calculate the mutual inductance of the coils and prove the formula used.

42. CATHODE-RAY TUBES AND TIME BASES

REFERENCES. *Cathode-Ray Tubes*, by M. von Ardenne; *Cathode-Ray Oscillography*, by McGregor-Morris; *The Cathode-Ray Tube*, by Parr; *Cathode-Ray Oscillographs*, by Reyner; *Cathode-Ray Tubes*, by Watson-Watt; *Time Bases*, by Puckle.

Cathode-ray Tubes

$$\text{Electric deflection} = \frac{0.5 \ell Ll}{V} \text{ cm.}$$

where V = p.d. between anode and cathode in volts,

ℓ = electric deflecting force in volts per cm. = v/d ,

v = p.d. between deflector plates in volts,

d = distance between deflector plates in cm.,

L = distance from centre of plates to screen in cm.

l = length of plates in direction of beam in cm.

$$\text{Magnetic deflection} = \frac{0.3 H L l}{\sqrt{V}} \text{ cm.}$$

where V = p.d. between anode and cathode in volts,

H = magnetic deflecting force in oersteds,

l = length of electron path through the field in cm.,

L = distance from centre of field to screen in cm.

If the whole of the beam lies in the magnetic field, then

$$\text{Magnetic deflection} = \frac{0.15 H L^2}{\sqrt{V}} \text{ cm.}$$

Linear Time Bases

(1) Neon type with fixed resistance.

$$\text{Sweep frequency } f = \frac{1}{T} \text{ kc/s}$$

$$\text{where } T = CR \log_h \frac{V - V_s}{V - V_e}$$

C is the charging capacitance in μF .,

R is the charging resistance in $k\Omega$,

V is the d.c. supply voltage,

V_e is the striking voltage of the lamp,

V_s is the extinction voltage of the lamp.

(2) Soft-valve type with constant charging current.

$$\text{Sweep frequency } f = \frac{I}{CV} \text{ kc/s.}$$

C is the capacitance in $\mu\text{F.}$,

I is the charging current in mA.,

V is the difference between the striking and extinction voltages.

(3) Multivibrator type.

$$\text{Recurrence frequency } f = \frac{1}{T} \text{ kc/s}$$

$$\text{where } T = C_1 R_1 \log_h \frac{V_2}{v_1} + C_2 R_2 \log_h \frac{V_1}{v_2}$$

C is the grid capacitance in $\mu\text{F.}$,

R is the grid resistance in $k\Omega$,

V is the static p.d. across the anode resistance,

v is the static cut-off grid bias ($V = 0$).

The suffixes relate to the respective valves.

EXAMPLES 42

1. In a cathode-ray tube, the length of the deflecting plates in the direction of the beam is 1.27 cm., the spacing of the plates is 0.475 cm., and the distance from the centre of the plates to the screen is 20 cm. Calculate the approximate voltage between plates to produce a deflection of 1 cm. on the screen if the potential between anode and cathode is (a) 150 volts, (b) 300 volts.

2. In a cathode-ray tube employing magnetic deflection, the distance from the centre of the coils to the screen is 20 cm. and the magnetizing force produced by the coils is 1.2 oersteds along a distance of 4.3 cm. in the direction of the beam. Calculate the approximate deflection produced when the anode voltage is (a) 100 volts, (b) 400 volts.

3. The spot of a cathode-ray tube is displaced vertically by a magnetizing force of 2 oersteds. Calculate the potential which should be applied to the horizontal deflecting plates, which are 0.5 cm. apart, to return the spot to the centre of the screen. The anode voltage is 400 and the length of the deflecting plates is the same as that of the magnetic field.

4. A cathode-ray tube, supported with its axis vertical, has an anode potential of 625 V. If the distance from the anode to the screen is 25 cm., calculate the deflection of the spot due to the earth's field ($H = 0.18$).

5. In a simple neon time base, the charging resistance and capacitance are 0.3 megohm and 0.016 microfarad respectively. The neon lamp strikes at 170 V. and is extinguished at 140 V. Calculate the time constant of the charging circuit and the approximate frequency of the time base if the supply voltage is 200.

6. A linear time base employs a saturated diode in conjunction with a gas triode. The striking voltage and the internal volt drop of the latter are 270 V. and 20 V. respectively. If the diode charging current is 5 mA. and the capacitance is variable from 0.001 to 1.0 microfarad, calculate the sweep frequency range of the time base.

7. In a symmetrical multivibrator, with a high-tension supply of 250 V., each valve has an anode voltage of 110 V. with the coupling capacitor removed, while the static cut-off grid bias is 20 V. with full anode voltage. Calculate the recurrence frequency if each grid capacitance and resistance are 0.006 μF . and 50 $k\Omega$ respectively.

43. WAVEMETERS

EXAMPLES 43

1. Describe the construction and use of any form of wavemeter, and give an outline of a means of its calibration.

(*C. & G.*, 1, 1928.)

2. Describe how a wavemeter may be accurately calibrated by reference to a tuning fork.

(*C. & G.*, *Final*, 1926.)

3. A tuning fork is maintained in oscillation at 2 000 cycles per sec., and by means of a triode it produces a current in which higher harmonics are observable. This current induces an e.m.f. in a heterodyne wavemeter tuned by a variable capacitance C . It is known that when $C = 114$ millimicrofarads the wavelength is approximately 16 000 m. Heterodyne screams are observed with their centres of silence at 146.0, 115.3, 80.0, 50.0, and 35.5 millimicrofarads respectively. Plot a calibration curve of the wavemeter, and from it read the true wavelength at 114 millimicrofarads. (*I.E.E.*, *Nov.*, 1929.)

4. Describe how to calibrate a wavemeter from the harmonics of a source of known frequency. Illustrate the procedure by numerical examples. (I.E.E., May, 1930.)

5. Describe the construction and method of use of a wavemeter, suitable for use at a transmitting station, for measuring the wavelength of both spark and C.W. transmitters.

(C. & G., 1, 1931.)

6. Describe, with diagrams, an apparatus with which a wavemeter can be calibrated in terms of a standard tuning fork.

(I.E.E., May, 1931.)

7. Describe the process of calibrating a wavemeter by means of harmonic ratios and a single standard transmission of known frequency.

(I.E.E., May, 1932.)

8. Describe the construction and principle of action of a resonant type wavemeter suitable for measuring the wavelength of a spark transmitter. What precautions should be taken to minimize error when using the instrument?

(C. & G., 1, 1933.)

9. A wavemeter consists of a variable condenser having a range of from 50 to 1 000 micromicrofarads and two coils of 300 and 100 microhenries respectively. If the coils are fixed so that their mutual inductance is 25 microhenries, what range will the wavemeter have when the coils are used (a) in series aiding, (b) in series opposing, (c) in parallel aiding, (d) in parallel opposing?

(I.E.E., Nov., 1933.)

10. Describe the construction of simple type of wavemeter suitable for measuring the wavelength of a spark or I.C.W. transmitter. How would you use such a wavemeter in conjunction with a buzzer and inductance to compare the capacitances of two condensers?

(C. & G., Prelim., 1935.)

11. Describe a simple type of resonance wavemeter. If the condenser of the wavemeter is variable from 50 to 450 micromicrofarads, calculate the values of the inductances required to permit the wavemeter being used over a wave band of from 100 to 2 000 metres.

(C. & G., Prelim., 1937.)

12. Describe a suitable type of wavemeter to give an approximate check upon the frequency of a short-wave transmitter.

(C. & G., 2, 1941.)

44. TELEVISION

REFERENCES. *Television*, by Reyner (Chapman & Hall); *Television*, by Zworykin and Morton; *Principles of Television Engineering*, by Fink; *Television Engineering*, by Wilson.

The frequency band required for a picture scanned along its longer dimension is

$$f = pl^2r/2$$

where p = rate of picture repetitions,

l = number of scanning lines per picture,

r = ratio of longer to shorter dimension of the picture.

EXAMPLES 44

1. Find the frequency band necessary to be transmitted in a 30-line scanning system with a picture ratio of 2.4 and a scanning speed of 12.5 per sec.

2. Calculate the permissible scanning speed per second for a 60 by 72 element picture to keep the frequency band within 45 kilocycles.

3. Determine the wavelength for the transmission of a 120-line system, with a picture ratio of 4/3 and 20 picture repetitions per second if the frequency band is to be about 0.45 per cent of the carrier frequency.

4. Assuming double side-band transmission, calculate the band width necessary in a 405-line system with 25 pictures per second and a picture ratio of 4/3.

45. ACOUSTICS

REFERENCES. *Applied Acoustics*, by Olson & Massa (Blakiston); *Modern Acoustics*, by Davis (Bell); *Acoustical Engineering*, by West (Pitman).

The reverberation time for a room in which the average absorption coefficient is less than 0.2 is given approximately by Sabine's formula—

$$T = \frac{0.05V}{a_1S_1 + a_2S_2 + \dots} = \frac{0.05V}{\Sigma aS} \text{ seconds}$$

where V = volume of room in cubic feet.

a_1, a_2 = absorption coefficients of the various surfaces of areas S_1, S_2 square feet.

For rooms in which the average absorption coefficient is greater than 0.2, use may be made of Eyring's formula—

$$T = \frac{-0.021V}{S \log(1-a)}$$

$$\text{where } a = \frac{a_1 S_1 + a_2 S_2 + \dots}{S_1 + S_2 + \dots}$$

$$\text{and } S = S_1 + S_2 + \dots$$

or Millington's formula—

$$T = - \frac{0.021 V}{S_1 \log(1 - a_1) + S_2 \log(1 - a_2) + \dots}$$

$$= - \frac{0.021 V}{\Sigma S \log(1 - a)}$$

EXAMPLES 45

1. An auditorium has a volume of 260 000 cubic feet. The concrete floors occupy 9 600 square feet, the plaster walls and ceiling 26 000 square feet, curtains 800 square feet, and wood seats 7 500 square feet. The absorption coefficients of the materials are 0.015, 0.033, 0.25, and 0.04 respectively. Calculate the reverberation time of the hall when empty.

2. The auditorium in the preceding problem has a seating capacity of 1 500. Assuming that the absorption of the audience per person is 4.7 units, calculate the reverberation times when the hall is (1) one-third full, (2) two-thirds full, and (3) full.

3. If the seats in the hall of the preceding questions are upholstered to raise the absorption coefficient to 0.3, find the reverberation times of the room when it is (1) empty, and (2) two-thirds full.

4. A room 21 feet long, 18 feet wide, and 8 feet high has its walls and ceiling covered with material having an absorption coefficient of 0.7 and the floor covered with material having an absorption coefficient of 0.4. Find the reverberation time, using (a) Eyring's formula and (b) Millington's formula.

46. MISCELLANEOUS

EXAMPLES 46

1. Write a short account of one of the following—

- (a) The quartz-crystal oscillator.
- (b) Reception by super-heterodyne.
- (c) Progress in short-wave working.

(C. & G., Final, 1926.)

2. Write a short account of the causes and effects of corona. In what respects do these phenomena affect the design of a wireless station? *(I.E.E., Oct., 1926.)*
3. Describe the action of one type of frequency changer as used on a radio transmitter. *(C. & G., Final, 1928.)*
4. Describe, with sketches, either (a) any type of automatic call device, or (b) a Wheatstone transmitter and receiver. *(C. & G., Final, 1928.)*
5. What is the Armstrong super-regenerative circuit? For what range of frequencies is it most suitable? What are the advantages and disadvantages of this circuit? *(C. & G., Final, 1928.)*
6. Describe the effect of eddy currents in conductors carrying high-frequency currents. State what steps are taken in practice to minimize these effects. *(C. & G., 1, 1929.)*
7. An alternator having a terminal voltage of 120 volts (r.m.s.) is connected to the primary of a transformer having a primary to secondary ratio of 1 to 30. A resistance of 5 000 ohms is connected across the secondary terminals. What is the primary current and what is the equivalent resistance in the primary circuit? *(C. & G., 1, 1929.)*
8. Describe the difficulties and advantages of using one wavelength for several neighbouring broadcasting stations. *(I.E.E., Nov., 1929.)*
9. Explain how sustained vibrations of a tuning fork may be obtained without the use of contacts. Outline the design conditions necessary for success. State any uses to which the device may be put. *(L.U., 1930.)*
10. Describe some mountings suitable for longitudinal and for transverse quartz resonator crystals. Discuss the mountings and types of resonator in respect of temperature coefficient, uniqueness of response, and effect of atmospheric conditions. *(I.E.E., May, 1930.)*
11. Why is the high-frequency resistance of an inductance coil higher than the d.c. resistance? State the methods that are adopted to reduce the high-frequency resistance in coils. *(C. & G., 1, 1931.)*
12. Describe two types of static frequency changer or frequency multiplier used for high-frequency transmitters. What are the advantages and disadvantages of such apparatus? *(C. & G., Final, 1932.)*
13. Show roughly by means of a sketch the current density in a solid cylindrical conductor when carrying a high-frequency current, and explain the reason for any variation in density.

What steps are taken in practice to avoid excessive losses and uneconomical use of material in high-frequency conductors?

(*C. & G.*, 1, 1933.)

14. Describe with sketches the construction and method of operation of any type of automatic alarm device in actual use on ships.

(*I.E.E.*, May, 1933.)

15. Describe the construction of two types of high-value resistors used for high-frequency receiving circuits. What precautions are taken in practice to reduce the self-capacitance of such resistors?

(*I.E.E.*, Nov., 1933.)

16. Describe the construction of an L.F. iron cored transformer. What effect has an air gap in the magnetic circuit on the performance of a transformer?

(*C. & G.*, *Prelim.*, 1935.)

17. What methods are adopted to reduce eddy current losses in (a) inductances, (b) iron cores used for L.F. transformers, (c) iron cores used for H.F. transformers?

(*C. & G.*, *Prelim.*, 1935.)

18. Describe the principles and mode of operation of any type of distress call apparatus in use at the present day.

(*C. & G.*, *Inter.*, 1935.)

19. Describe, with a sketch, the construction and action of a cathode-ray tube. Give a diagram of a circuit for producing a time base for use with a cathode-ray tube.

(*C. & G.*, *Final*, 1935.)

20. What is the difference between a potential transformer and a current transformer? Why must the latter type of transformer always be worked with the secondary winding connected across a very low impedance? A transformer having 1 000 turns on the primary winding and 200 turns on the secondary winding has a resistance of 250 ohms connected across the secondary terminals. What is the apparent a.c. resistance of the transformer and resistance measured across the primary terminals?

(*C. & G.*, *Prelim.*, 1936.)

21. The output from a frequency multiplier contains 4 A. r.m.s. at fundamental frequency, 5 A. r.m.s. at double the fundamental frequency and 3 A. r.m.s. at three times the fundamental frequency. What current would be indicated on a hot-wire ammeter?

(*C. & G.*, *Inter.*, 1936.)

22. Two solid copper wires, one very thin and the other many times thicker, are of such lengths that their resistance is the same to low-frequency currents. Would you expect their resistances to change to the same extent at very high frequencies? Give reasons for your answer.

(*C. & G.*, 1, 1940.)

47. RADIO SERVICE WORK

REFERENCES. *Wireless Servicing Manual*, by Cocking; *Radio Service Manual*, by Harris; *Principles and Practice of Radio Servicing*, by Hicks.

EXAMPLES 47

1. How does an alternating current differ from a direct current? Define frequency, peak voltage, and r.m.s. voltage
(*C. & G.*, 1, 1938.)

2. The following quantities have to be measured—
 (a) h.t. voltage applied to the anode of a valve;
 (b) l.t. voltage applied to the filament of a valve;
 (c) anode current.

In each case state the type of meter you would use, and give a suitable diagram of connections. (*C. & G.*, 1, 1938.)

3. A valve connected to a heater circuit and with a fixed grid bias is connected in series with a 50 000-ohm resistance to a high-tension supply of 200 volts. The p.d. measured from anode to cathode is 80 volts when a voltmeter of 100 000 ohms resistance is employed. What is the resistance within the valve between anode and cathode? (*C. & G.*, 1, 1938.)

4. Explain how you would test two of the following components—

- (a) Low-frequency transformer.
 (b) Mica dielectric fixed condenser 0.0005 mfd.
 (c) Medium-wave tuning coil.
 (d) A mains-energized moving-coil loud-speaker.
 (e) Carbon track potentiometer volume control.

(*C. & G.*, 1, 1938.)

5. A 1-ampere fuse is connected in series with the primary winding of a mains transformer which has 400 primary turns and 1 000 secondary turns. What would be the open circuit secondary voltage when the primary is connected to 200-volt mains? What is the maximum current which may be taken from the secondary winding before the fuse will blow?

(*C. & G.*, 1, 1938.)

6. Sketch the essential parts of—
 either (a) a permanent magnet moving-coil loud-speaker,
 or (b) a permanent magnet gramophone pick-up.

Describe the operation of the example chosen.

(*C. & G.*, 1, 1938.)

7. How do electrolytic condensers differ from those of the ordinary paper and mica types? What advantage have they? Under what circumstances are they preferable to other types?

How would you test an alleged faulty electrolytic condenser of 8 mfd. capacity, designed to work in a 450-volt circuit?

(*C. & G.*, 1, 1938.)

8. Compare the behaviour of a condenser, connected in a d.c. circuit, with one of a similar capacity connected in an a.c. circuit. What effect has frequency upon the result when considering the a.c. case?

(*C. & G.*, 1, 1938.)

9. You are installing wireless apparatus in a house which has a telephone, hot and cold water systems, gas, and metal-clad electricity installation. Which of these, if any, would you employ for your earth connection? Give reasons for not choosing the others.

(*C. & G.*, 1, 1938.)

10. Draw a circuit of a diode rectifier valve connected to an a.c. supply. Show where the d.c. voltage can be measured, also indicate its polarity. Give an explanation of the rectifying action.

(*C. & G.*, 1, 1938.)

11. Given a multi-range meter, h.t., l.t., and g.b. batteries, detail all the tests you would apply to a directly heated triode valve. Illustrate one of the tests by a circuit diagram.

(*C. & G.*, 1, 1938.)

12. An a.c. receiver, operating from 200-volt mains, employs four valves of the 4-volt 1-ampere class. The total h.t. (unsmoothed) is 80 milliamperes at 300 volts. Both h.t. and l.t. are taken from the mains via a suitable transformer. How many watts does the primary winding consume? Why is the answer only approximate?

(*C. & G.*, 1, 1938.)

13. An indirectly heated valve is self-biased by a 1 000-ohm resistance connected between cathode and h.t. negative, the grid return being taken to h.t. negative. The valve passes 30 milliamperes anode current under normal conditions. What is the bias voltage developed across the cathode resistance? If a replacement resistance has to be fitted, would a $\frac{1}{2}$ -watt type be satisfactory? Give reasons.

(*C. & G.*, 2, 1938.)

14. Describe how a moving-coil meter with 100-ohm coil and a full scale deflection of 1 milliampere could be made to read—

(a) 250 volts full scale.

(b) 100 milliamperes full scale. (*C. & G.*, 2, 1938.)

15. Taking as an example a radio receiver with h.f. amplifying valve, detector, and l.f. amplifier, describe briefly alternative methods of controlling volume. Illustrate by simplified circuit diagrams.

(*C. & G.*, 2, 1938.)

16. A valve is rated to consume 2 milliamperes at 50 volts.

The full h.t. voltage is 250. What value dropping resistance should be employed to operate the valve at its correct anode voltage? Calculate the wattage of this resistance.

(C. & G., 1, 1939.)

17. The following condensers are available, each of "500 volt d.c. working" type—

- 0.002 microfarad.
- 0.003 "
- 0.005 "
- 0.006 "

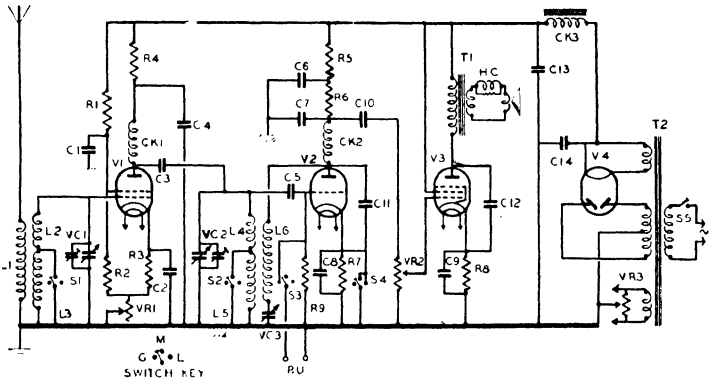

FIG. 17

- | | | | |
|-------------|---------------|--|-------------------|
| C1. 0.1 | mfd. | VR1. 15 000 | ohms |
| C2. 0.1 | " | VR2. 500 000 | " |
| C3. 0.0001 | " | VR3. 50 | " |
| C4. 2 | " | VC1. 0.0005 mfd. max. | } Ganged. |
| C5. 0.0001 | " | VC2. 0.0005 | |
| C6. 2 | " | VC3. 0.0005 | |
| C7. 0.001 | " | CK1. H.F. Choke. | } 100 ohms each. |
| C8. 2 | " | CK2. H.F. | |
| C9. 50 | electrolytic. | CK3. Loud-speaker Field | 2 000 ohms. |
| C10. 0.1 | " | HC. Hum Neutralizing Coil. | |
| C11. 0.0005 | " | T1. Output Transformer. | |
| C12. 0.002 | " | | Primary 350 ohms. |
| C13. 8 | electrolytic. | | Secondary 5 ohms. |
| C14. 8 | " | T2. Mains Transformer. | |
| R1. 35 000 | ohms. | L1. Aerial Coupling Coil. | |
| R2. 25 000 | " | L2. " " | 3 ohms. |
| R3. 250 | " | L3. " " | 12 " |
| R4. 5 000 | " | L4. " " | 3 " |
| R5. 10 000 | " | L5. " " | 12 " |
| R6. 50 000 | " | L6. Reaction Coil. | |
| R7. 1 000 | " | S1, S2, S3 and S4. Waveband and Gramophone Switch. | |
| R8. 100 | " | S5. Mains on/off Switch. | |
| R9. 500 000 | " | | |

How can a capacity of 0.004 microfarad be made up from these condensers? On what d.c. voltage would it be safe to use the condensers grouped in the way you propose?

(*C. & G.*, 1, 1939.)

18. Is it usual to fit mains transformers in a.c./d.c. receivers? Give reasons. What special principle is there in connection with the supply to the heaters of valves in these receivers? Why is it necessary?

(*C. & G.*, 1, 1939.)

19. Sketch the connections to a triode valve when used as an amplifier. Give a brief description of the amplifying action. How would negative grid bias be applied and why is it necessary?

(*C. & G.*, 1, 1939.)

20. There are in general use three methods of radio frequency rectification employing thermionic valves. What are these methods? Describe one in detail, showing graphically how low-frequency signals are produced as a result of rectification.

(*C. & G.*, 1, 1939.)

21. What would you say were the three commonest faults met in—

either (a) a permanent magnet moving-coil loud-speaker, or (b) a magnetic type of gramophone pick-up?

How would you repair these faults?

(*C. & G.*, 1, 1939.)

22. Describe briefly the functions of each valve in the receiver circuit given in Fig. 17: at the same time suggest suitable valve types. Should V1 have any special characteristics? If so, why?

(*C. & G.*, 1, 1939.)

23. Which controls affect the volume of signals obtained from the loud-speaker? How does each of these controls function?

(*C. & G.*, 1, 1939.)

24. A receiver of the type shown is employed in a radio-gramophone. Satisfactory radio signals are received but the gramophone does not operate. Give a list of the parts you would check and indicate the sequence of checking in order to locate the fault.

(*C. & G.*, 1, 1939.)

25. What components in the receiver would you suspect when—

(a) No voltage could be measured from anode to cathode of V2.

(b) The receiver worked satisfactorily on medium waves but was weak on long waves?

(*C. & G.*, 1, 1939.)

26. How would you test three of the following components used in the receiver shown—

(a) Choke CK1.

(b) Coil L2.

(c) Condenser C2.

(d) Transformer T1.

(e) Condenser C9 (electrolytic)? (*C. & G.*, 1, 1939.)

27. A receiver of the type shown is found to operate satisfactorily on gramophone but receives only the local station on medium waves. No reception at all is obtained on the long wave. A universal meter measuring volts, current, and resistance, is available. Detail the tests you would make in their correct sequence in order to locate the trouble.

(*C. & G.*, 1, 1939.)

28. Calculate the wavelength in metres of the following frequencies—

(a) 125 kc./s.

(b) 15 Mc./s.

What would be the third harmonic of a signal operating on 1 000 metres? (Velocity of propagation = 300 000 000 metres per second.)

(*C. & G.*, 2, 1939.)

29. Draw the essentials of a mains operated low-frequency amplifier, including tone controls for bass and treble. Describe how each type of control operates on a signal.

(*C. & G.*, 2, 1939.)

30. Many modern receivers are fitted with tuning indicators which enable the user to tune the receiver to resonance easily. Describe one of these indicators and show how it would be connected in a receiver. Can a tuning indicator be connected to a receiver which does not employ automatic volume control? Give reasons.

(*C. & G.*, 2, 1939.)

31. An indirectly heated pentode is used in the output stage of a mains receiver. If the anode current of the valve under normal operating conditions is 30 mA., how is the correct bias of 17.5 volts developed across a 500-ohm resistance connected between cathode and h.t. negative?

(*C. & G.*, 2, 1939.)

32. Give a brief description of one of the following test instruments, and describe the uses to which it might be put in radio servicing—

(a) All-wave oscillator. (b) Cathode-ray oscillograph.

(c) Valve voltmeter. (d) Audio-frequency oscillator.

(*C. & G.*, 2, 1939.)

33. Describe how you would carry out one of the following installations. How would you overcome the difficulties that would arise—

(a) Car radio in a saloon car, where the body and roof are all metal and coil ignition is employed.

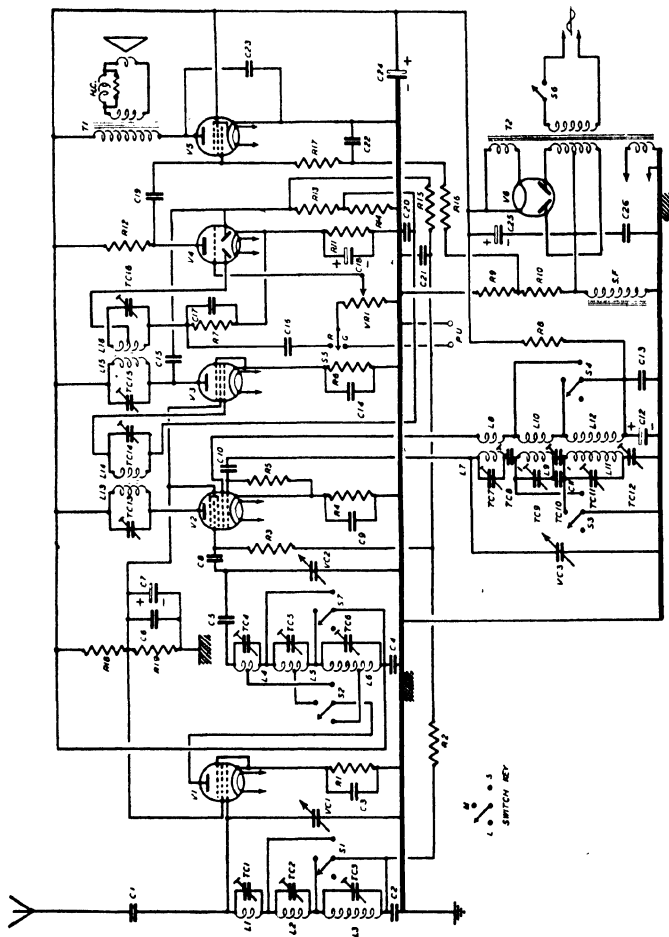

FIG. 18

Component	Value	Material	Value	Value	Description
C1.	0-00001	mfd.	0-05	mfd.	TC16—Trimmer Condensers.
C2.	0-05	"	350	ohms.	L1. Aerial coil.
C3.	0-1	"	75 000	"	L2. "
C4.	0-1	"	500 000	"	L3. High-frequency Coupling Coil.
C5.	0-1	"	250	"	L4. "
C6.	0-1	"	50 000	"	L5. "
C7.	4	electrolytic.	350	"	L6. "
C8.	0-00005	"	500 000	"	L7. Oscillator Coil.
C9.	0-1	"	25 000	"	L8. "
C10.	0-00005	"	8 500	"	L9. "
C11.	0-00035	"	50 000	"	L10. "
C12.	4	electrolytic.	750	"	L11. "
C13.	0-005	"	50 000	"	L12. Intermediate Frequency Coil.
C14.	0-1	"	500 000	"	L13. "
C15.	0-000075	"	500 000	"	L14. "
C16.	0-01	"	500 000	"	L15. "
C17.	0-0001	"	100 000	"	L16. "
C18.	25	electrolytic.	150 000	"	T1. Output Transformer.
C19.	0-05	"	25 000	"	T2. Mains
C20.	0-25	"	35 000	"	SF. Loud-speaker Field 1 600 ohms.
C21.	0-05	"	2 megohms.	"	HC. Hum Neutralizing Coil.
C22.	0-25	"	0-0005 mfd. max.	"	S1, S2, S3, S4, S7. Waveband Switch.
C23.	0-0025	"	0-0005	"	S5. Radio and Gramophone Switch.
C24.	8	electrolytic.	0-0005	"	S6. Mains on/off Switch.
C25.	8	"	"	"	"

} Ganged.

(b) Speech amplification in a large hall where the speeches are delivered from a platform at one end, the audience being divided between the ground floor and a balcony.

(c) A sensitive all-wave mains receiver has to be installed in a third floor flat of a ferro-concrete building near the centre of a busy town. There are six floors to the building, which is fitted with electric lifts. What precautions would you take to reduce electrical interference to an absolute minimum?

(C. & G., 2, 1939.)

34. Describe briefly the functions of each valve in the receiver whose diagram is given in Fig. 18. At the same time suggest suitable valve types.

(C. & G., 2, 1939.)

35. Which trimmer condensers will affect the overall performance of the receiver on the medium wave band? What is the function of each of these trimmers?

(C. & G., 2, 1939.)

36. Give a list of components on the attached circuit which go to make up the automatic volume control circuits. Has this receiver amplified, delayed, or full automatic volume control? Explain the action of this form of control.

(C. & G., 2, 1939.)

37. Describe tests which would check whether—

(a) The low-frequency section of the receiver was in order.

(b) The oscillator was functioning correctly.

(c) Automatic volume control was operating satisfactorily.

(C. & G., 2, 1939.)

38. How is the required grid bias developed and fed to V5 on the attached circuit? If the total h.t. current taken by all the valves is 70 mA., what is the bias voltage applied to V5?

(C. & G., 2, 1939.)

39. Describe briefly the functions of three of the following pairs of components as used in the attached circuit—

(a) C5 and C23.

(b) C6 and C13.

(c) R2 and C2.

(d) C18 and C16.

(e) TC8 and TC11.

(f) TC5 and TC1.

(C. & G., 2, 1939.)

40. A battery of 150 volts is connected across a resistance network of such a value that the current flow is 5 mA. Calculate (a) the value of the resistance network; (b) the watts dissipated by this resistance.

(C. & G., 1, 1940.)

41. Three resistances connected in parallel have an effective value of 25 000 ohms. Two of these resistances have values of

between cathode and H.T. negative has a value of 200 ohms? Give the wattage of the bias resistor. (*C. & G.*, 2, 1941.)

The following six questions refer to a radio receiver the circuit of which is given in Fig. 20.

89. The receiver shown has an intermediate frequency of 465 kc/s. Assume that a signal of 1 000 kc/s is being received and describe in detail the passage of this signal through the receiver. (The receiver is connected to a.c. mains.)

(*C. & G.*, 2, 1941.)

90. The receiver (for the purpose of this question) is connected to d.c. mains. What do you consider is likely to be wrong in the three following cases—

(a) Valves, visual tuner and pilot lamps do not light.

(b) Valves, visual tuner and pilot lamps light, but screen of visual tuner does not fluoresce, and no signals are heard at all.

(c) When receiver is switched "on" the fuse F1 blows.

(*C. & G.*, 2, 1941.)

91. How many valves in this receiver are controlled by A.V.C.? Give a list of the components which go to make up the A.V.C. circuit. Is the visual tuner controlled by the same circuit? How does this type of indicator operate?

(*C. & G.*, 2, 1941.)

92. Explain briefly the functions of the following components: (a) R21; (b) CK3, C36; (c) R24; (d) C16; (e) C23.

(*C. & G.*, 2, 1941.)

93. Describe the effect each of the following breakdowns would have on the operation of the receiver: (a) C6 shorting; (b) C33 shorting; (c) R20 open circuit; (d) R5 open circuit.

(*C. & G.*, 2, 1941.)

94. Give a full description of the correct method of realigning all the tuned circuits of this receiver. What test instruments are required for this operation, and where should they be connected?

(*C. & G.*, 2, 1941.)

ANSWERS TO QUESTIONS

EXAMPLES I

3. 5.09 kW. 5. About $3 \mu\mu\text{F}$. 7. 3 186 $\mu\mu\text{F}$. 8. Energy stored in condenser = $\frac{1}{2}CV^2 = \frac{2 \times 1\,000^2}{2 \times 10^6}$ joules
= 1 joule. *Ans.*

Condensers in parallel share the original charge

$$\therefore CV = (C + C_1)V_1$$

$$\therefore V_1 = \frac{2 \times 1\,000}{2 + 3} = 400 \text{ volts. } \textit{Ans.}$$

Total energy after connection = $\frac{5 \times 400^2}{2 \times 10^6}$ joules
= 0.4 joules. *Ans.*

The difference in energy is due to that dissipated in the spark on connecting the second condenser.

9. 59 $\mu\mu\text{F}$; 3.33 kV. per cm.

10. (a) $C = kA/4\pi d \propto 1/d$

If d is doubled, C is halved. *Ans.*

(b) $I = V\omega C$. This remains the same, since V is doubled and C is halved. Hence the volt-amperes are doubled. *Ans.*

(c) Since the spacing is doubled, the volume of dielectric is doubled and the volt-amperes per unit volume remain the same. *Ans.*

11. 2.25. 12. 3.56. 13. 3.12. 14. 0.0005 joules; 0.005 joules.

15. 0.18 μF . 17. 8. 18. $\omega^2 C^2 Rr = 1$; 79.6 kc./s.

EXAMPLES 2

1. 0.353 mH. 2. 853 μH . 3. (a) 4 712; (b) 1 047 ohms. 4. 1.67 mH.

5. 2:1. 6. 21.2 milliseconds. 7. 1.13 mH. 8. 1.24 milliseconds.

9. 6.2 ohms; 0.62. 10. 0.216 A.; 1.69 A/s. 11. 0.002 sec.

EXAMPLES 3

1. 252. 2. $V_C = 500$; $V_L = 400$; $V = 100$. 3. 0.8 μF ; 2.16 ohms. 5. 0.14 A.; 88° lagging. 6. 12.57 kV. 7. 33.53 mA.; $V_C = 5.34$; $V_R = 0.335$; $V_L = 105.4$.

8. When $\lambda = 1000 \text{ m.}$, $f = \frac{3 \times 10^8}{10^3} = 3 \times 10^5$

$$\therefore \omega = 6\pi \times 10^5.$$

$$\omega L = \frac{1}{\omega C} = \frac{10}{6\pi \times 10^5 \times 0.0015} = \frac{10}{0.009\pi} = 353.68$$

When $\lambda = 1\ 005\ \text{m.}$, $\omega L = \frac{353.68}{1.005} = 351.94$

$$\frac{1}{\omega C} = 353.68 \times 1.005 = 355.45$$

$$X = 355.45 - 351.94 = 3.51$$

$$Z = \sqrt{R^2 + 3.51^2} = 2R$$

$$R^2 + 3.51^2 = 4R^2$$

$$\therefore R = \sqrt{(3.51^2/3)} = 3.51/\sqrt{3} = 2.03\ \text{ohms. Ans.}$$

9. 10.61 kV.; 17.68 kV. 10. 0.305 A. 11. (a) 58.5 V.; (b) 8.92 V.

12. $\frac{1}{\omega C} = \frac{10^6}{100\pi \times 4} = 795.8$

$$L = (10 \times 5)/(10 + 5) = 10/3\ \text{H.} \quad \therefore \omega L = 100\pi \times (10/3) = 1047.2$$

$$X = 1047.2 - 795.8 = 251.4$$

$$Z = \sqrt{(400^2 + 251.4^2)} = 472.4$$

$$\therefore I = \frac{100}{472.4} = 0.212\ \text{A. Ans.}$$

13. 0.672 A. 14. 248 ohms. 15. 13.78 mA. 17. $R = 52\ \text{ohms}$; $L = 6\ \text{mH}$. 18. 445; 438; 452 kc. 19. 0.317 H; 632 ohms. 20. 53.2 V.; 84.7 V.; 1.59. 21. 55.1 μH . 22. 70.7 V.

EXAMPLES 4

1. $[R_1 - \omega^2 LCR_c + j\omega(CR_c R_1 + L)]/[1 - \omega^2 LC + j\omega C(R_c + R_1)]$

2. $\frac{1}{Z} = \frac{1}{80\sqrt{30^\circ}} + \frac{1}{24 + 70j} = 0.0125\sqrt{30^\circ} + \frac{24 - 70j}{24^2 + 70^2}$
 $= 0.0125 \cos 30^\circ + 0.0125j \sin 30^\circ + \frac{24 - 70j}{5\ 476}$
 $= 0.010825 + 0.00625j + 0.004382 - 0.01278j$
 $= 0.01521 - 0.00653j$

$$\therefore Z = \frac{1}{0.01521 - 0.00653j} = \frac{0.01521 + 0.00653j}{0.01521^2 + 0.00653^2} = 55.48 + 23.84j. \text{ Ans.}$$

The modulus is $\sqrt{(55.48^2 + 23.84^2)} = 60.38\ \text{ohms. Ans.}$

3. $[(C + K)/C]^2 R$. 4. 0.8 volt. 5. 1.59 A., leading $3^\circ 26'$.

6. - 0.16 H, (the coil is condensive); 0.5 megohm.

7. Let r and l be the required resistance and inductance respectively.

Then $Z = \frac{1}{1/r + 1/j\omega L} = \frac{j\omega l r}{r + j\omega l} = \frac{j\omega l r(r - j\omega l)}{r^2 + \omega^2 l^2}$
 $= (j\omega l r^2 + \omega^2 l^2 r)/(r^2 + \omega^2 l^2) = R + j\omega L$
 $\therefore R = \omega^2 l^2 r/(r^2 + \omega^2 l^2) \quad L = l r^2/(r^2 + \omega^2 l^2)$
 $R/L = \omega^2 l/r \quad \therefore l = Rr/\omega^2 L$

Solving these equations gives $r = R + \omega^2 L^2 / R$

$$l = L + R^2 / \omega^2 L. \text{ Ans.}$$

8. 318; (a) 5.37×10^4 ; (b) 10^6 ohms.
 9. 0.212 mA.; 0.377 mA.; 0.165 mA.
 10. 176.3 ohms.; 6.635 mH.; 0.0085.
 11. 55.9 ohms. 12. 0.922 A.
 13. 63.5 mA. lagging $86^\circ 22'$; 4.09 mA. lagging $8^\circ 5'$.
 15. 70.7; 92.8 ohms respectively. 16. 0.142 A. 17. 961 V.
 18. 33.3 mA. lagging 90° . 19. 200 V.; 4 A.; 3 A.

EXAMPLES 5

1. 145.3 kc.; 1 A. 2. 492.6 μ H.; 321.4 μ F.
 3. 0.721 kW.; 10.13 μ F. in series; 2.5 kW.
 4. 1 333 metres; 596 metres. 5. 97.44 kc. s. 6. 50 ohms.
 106.1 kc./s.

$$\begin{aligned} 8. Z &= \frac{1}{1/(R + j\omega L) + j\omega C} + R + j\omega L = \frac{R + j\omega L}{1 - \omega^2 LC + j\omega CR} \\ &\quad + R + j\omega L \\ &= \frac{j(R + j\omega L)}{j^2 \omega CR} + R + j\omega L = \frac{\omega L}{\omega CR} - \frac{j}{\omega C} + R + j\omega L \\ &= R + \frac{L}{CR} + j\left(\omega L - \frac{1}{\omega C}\right) = R + \frac{L}{CR} \end{aligned}$$

Hence, resistance is $R + L/CR$; reactance is zero. *Ans.*

9. 1.25 ohms; 8.94 mA 10. 34. 11. $\lambda_1 = 1\ 334$ m.; $\lambda_2 = 436$ m.
 12. 0.507 μ H. 13. 3.33 μ F.; 3.04 H.; 637 ohms. 14. 103-326 m.
 15. 0.5; 9.19 m μ F.

EXAMPLES 6

1. 538 kc./s.; 297.6 volts. 2. 1 mA.; 0.998 mA.; 60 μ A.

3. Now $\delta = R/2fL \therefore R = 2fL\delta$

Impedance of circuit $Z = L/CR$

$$\therefore \text{p.d. across it} = LI/CR = V$$

$$\text{Current in condenser} = V\omega C = LI\omega C/CR = LI\omega/R$$

$$= 2\pi f LI/2fL\delta = \pi I/\delta$$

$$= \frac{\pi \times 10 \times 100}{1\ 000 \times 2} = 1.571 \text{ A. Ans.}$$

4. 2619 μ F. 5. 6670; 1960; 1870 ohms respectively.
 6. 10^6 . 7. 993 μ F.; 1013 μ F.

EXAMPLES 7

8. 36 760. 10. 45.4 ohms. 11. 127 μ H.; 8.04 ohms; 0.0101.

EXAMPLES 8

1. 4.33 A. 2. 2.91 %. 3. 4.94 %. 5. 63.66 μ H. 6. 0.628 volt.

$$\begin{aligned} 7. \text{ Now } f &= \frac{1}{2\pi\sqrt{LC}} = \frac{10^6}{2\pi\sqrt{(1\ 700 \times .001)}} = \frac{10^6}{2\pi\sqrt{1.7}} \\ &= 122.1 \text{ kc./s.} \end{aligned}$$

$$k = \frac{2}{\sqrt{(17 \times 17)}} = \frac{2}{17} = 0.1176$$

$$\sqrt{(1+k)} = \sqrt{1.1176} = 1.057$$

$$\sqrt{(1-k)} = \sqrt{0.8824} = 0.9393$$

$$\therefore f_1 = \frac{122.1}{1.057} = 115.5 \text{ kc./s.}$$

$$f_2 = \frac{122.1}{0.9393} = 130 \text{ kc./s. Ans.}$$

9. (a) 450 $\mu\text{H.}$; (b) 250 $\mu\text{H.}$; (c) 90 $\mu\text{H.}$; (d) 50 $\mu\text{H.}$
 10. Now $e = \omega MI = 2\pi \times 10^5 \times 10^{-6} \times 10^2$
 $= 20\pi$
 $Z = \sqrt{(16 + 16\pi^2)}$ since $X = 2\pi \times 10^5 \times 20 \times 10^{-6}$
 $= 4\pi$
 $\therefore I = \frac{20\pi}{4\sqrt{10.87}} = 4.765 \text{ A. Ans.}$
 11. $Z = R_1 + \frac{\omega^2 M^2 R_2}{Z_2^2} + j\left(X_1 - \frac{\omega^2 M^2 X_2}{Z_2^2}\right)$
 13. Primary 7.94 A.; secondary, 3.67 A.
 14. 0.88 mA. 15. 12 $\mu\text{H.}$
 16. 159.2 kc.; primary, 9.9 mA.; secondary, 0.99 mA.
 17. 848. 18. 0.158 A. 19. 80 kc.; 5 mA.; 0.125 mA.
 21. 122.5 ohms. 22. 0.03; 10.7 kc./s.; 15.1 kc./s. 23. 1820 ohms.
 24. 0.25 A. 25. 10.35 mA.

EXAMPLES 9

3. 43. 4. 41.
 5. $\delta = \pi R\sqrt{(C/L)} = \pi \times 15\sqrt{(0.01/1000)} = 15\pi/100\sqrt{10}$
 $= 0.15$
 $N = 1 + \frac{4.605}{0.15} = 1 + 30.7 = 31.7$
 $t = 2\pi\sqrt{(LC)} = 2\pi\sqrt{\frac{1000 \times 0.01}{10^6 \times 10^6}} = \frac{2}{10^5}$
 $\therefore T = \frac{31.7 \times 2}{10^5} = 0.634 \text{ millisecond. Ans.}$
 6. 93. 7. (i) 0.0147; (ii) 0.369 millisecond; 314; (iii) 1067 ohms.
 9. 20 ohms.

EXAMPLES 10

9. 0.0133 H. 11. 10 kW.
 12. Now $\frac{1}{2}CV^2 = \frac{1}{2}LI^2$
 $\therefore I^2L = V^2C$
 $\therefore I = V\sqrt{\frac{C}{L}} = 2 \times 10^4 \sqrt{\frac{0.025 \times 10^6}{10^6 \times 1}}$
 $= 2 \times 10^3 \sqrt{2.5} = 3162 \text{ A. Ans.}$
 $f = 1/2\pi\sqrt{(LC)} = 1/2\pi\sqrt{(10^{-6} \times 0.025 \times 10^{-6})} = 10^6 \text{ cycles. Ans.}$
 14. 4.4 mH.

EXAMPLES 11

4. (a) 20; (b) 10.

EXAMPLES 12

$$1. \frac{1}{4} \cdot \frac{d^2i}{dv^2} [a^2(1 - \cos 2pt) + b^2(1 - \cos 2qt)] \\ + [2ab \{ \cos (p - q)t - \cos (p + q)t \}]$$

5. Let the equation of the rectifier characteristic be

$$i = a + bv + cv^2 + dv^3$$

Then $di/dv = b + 2cv + 3dv^2$

$$d^2i/dv^2 = 2c + 6dv$$

Hence rectified current is $E^2(c + 3dv)$ where v is the no-signal grid voltage. *Ans.*

EXAMPLES 13

8. Since the valve amplification factor is 7, a change of V volts on the anode is equivalent to a change of $V/7$ volts on the grid for a given anode current.Hence at the anode potential of 150 volts, the anode current will be 1.0 mA. at a grid potential of $(50 - 150)/7 = -14.3$ volts.

Similarly for each other anode current, giving the curve—

Anode current, mA. . .	1.0	3.5	6.5	9.3	10.1
Grid potential, volts . .	-14.3	-7.1	0	7.1	14.3 <i>Ans.</i>

9. At zero grid voltage, the anode current changes 5 mA. for 30 V. change on the anode.

$$\text{Hence internal impedance} = \frac{30 \times 1000}{5} = 6\,000 \text{ ohms. } \textit{Ans.}$$

The anode current is 10 mA. when $V_g = 0$, $V_a = 100$, and also when $V_g = -5$, $V_a = 130$.

$$\text{Hence amplification factor} = 30/5 = 6. \textit{Ans.}$$

For a constant anode potential of 100 volts, the anode current changes 2 mA. for a change of 2 volts on the grid.

$$\text{Hence mutual conductance} = 2/2 = 1 \text{ mA. per volt. } \textit{Ans.}$$

12. 10.7 21. 5.3; 4.3; 3.2 mA. 23. 15 000; 13 000 ohms respectively. 25. 15 700 ohms; 5.96; 0.38 mA/V. 26. 6.15 mA/V. 27. (a) 0.39; 0.64; 0.91; 1.18; 1.48; (b) 0.15; 0.23; 0.3; 0.39; 0.45 mA. 28. 1.5 mA./V. 29. 18.3 V.

EXAMPLES 14

$$8. \quad V_g = \frac{R}{\sqrt{R^2 + X^2}} \cdot V = 0.9V$$

$$\therefore R = 0.9\sqrt{R^2 + X^2} \text{ i.e. } R^2 = 0.81R^2 + 0.81X^2$$

$$\therefore 1/\omega C = X = R\sqrt{0.19/0.81}$$

$$C = \frac{10^{13}}{2\pi \times 10^6 \times 0.1 \times 10^6} \sqrt{\frac{0.81}{0.19}} \mu\mu\text{F.}$$

$$= 32.86 \mu\mu\text{F. Ans.}$$

9. $cE^2R/[1 + 2cR(e_g + v)]$ where $i = c(e_g + v)^2$ represents the equation of the curve and e_g is the pre-signal grid voltage.

10. 1.72 mA.

12. Let the characteristic be represented by

$$i = a(b + v)^2$$

$$\text{Then } 8 = ab^2$$

$$\text{also } 2 = a(b - 5)^2$$

$$\therefore \text{ by division, } 4 = [b/(b - 5)]^2$$

$$1 - 5/b = \pm 1/2 \text{ and } b = 10/3 \text{ or } 10$$

The value $b = 10/3$ is inadmissible.

$$\therefore a = 8/100 = 0.08$$

$$\text{Now } di/dv = 2a(b + v) \text{ and } d^2i/dv^2 = 2a = 0.16$$

$$\therefore \text{ Rectified current } I = \frac{1.5^2}{2} \times 0.16$$

$$= 0.18 \text{ mA, Ans.}$$

14. 0.4 mA.

EXAMPLES 15

✓ 1. (a) 0.95; (b) 238Ω; (c) 0.42 MΩ. 2. 0.85 volt. 3. 2.25.

$$4. (1) \text{ Amplification} = \mu \cdot \frac{R}{R + \rho}$$

$$= \frac{25 \times 30\,000}{30\,000 + 30\,000} = 12.5 \text{ Ans.}$$

$$(2) \text{ Amplification} = \mu \cdot \frac{L}{L + \rho cR}$$

$$= \frac{25 \times 5 \times 10^{-3}}{5 \times 10^{-3} + 3 \times 10^4 \times 0.001 \times 10^{-6} \times 25}$$

$$= 21.74. \text{ Ans.}$$

$$5. (a) \quad X = \omega L = 2\pi \times 100 \times 10 = 2\,000\pi$$

$$\therefore m = \frac{7 \times 3 \times 2\,000\pi}{\sqrt{(49 \times 10^6 + 4\pi^2 \times 10^6)}}$$

$$= 42\pi/\sqrt{88.48} = 14. \text{ Ans.}$$

$$(b) \quad X = \omega L = 2\pi \times 400 \times 10 = 8\,000\pi$$

$$m = \frac{7 \times 3 \times 8\,000\pi}{\sqrt{(64 \times 10^6\pi^2 + 49 \times 10^6)}}$$

$$= 168\pi/\sqrt{680.7} = 20.2. \text{ Ans.}$$

8. 10 volts. 10. 45.8. 13. 5.75. 14. 1 266 $\mu\mu\text{F.}$; 13.45; 0.447.
 15. 25.5 decibels. 16. 10.1. 17. 34.14; 74.47; 138.2; 140.
 18. 22.36. 20. 12.5. 21. 14.87. 22. 5 000 ohms.
 24. (a) 113 db. (b) 70 db.

$$26. (a) \quad m = \frac{\mu}{1 + \rho CR/L} = \frac{20}{1 + .5} = 13.33 \text{ Ans.}$$

$$(b) \quad \omega = 9 \times 10^4 \sqrt{10} \quad \omega L = 900 \sqrt{10} \quad 1/\omega C = (1000 \sqrt{10})/0.9$$

$$\frac{1}{Z} = \frac{200 - 900j\sqrt{10}}{4 \times 10^4 + 81 \times 10^5} + \frac{0.9j}{1000\sqrt{10}}$$

$$\frac{\rho}{Z} = 2.5 \left[\frac{200 - 900j\sqrt{10}}{814} + 0.9j\sqrt{10} \right]$$

$$= 0.6142 - 1.625j$$

$$\therefore m = \frac{\mu}{1 + (\rho/Z)} = \frac{20}{1.614 - 1.625j} = 8.73 \text{ Ans.}$$

31. 8.5; 20 000 ohms. 34. 27.7 V. 36. 9.68. 37. 14.87.

38. 8.14 A; 0.8 neper.

39. The actual circuit is equivalent to one in which the secondary resistance R is replaced by a resistance R/T^2 in parallel with the primary inductance L , where T is the transformation ratio. This parallel circuit therefore forms the load impedance of the valve.

$$\text{Then } m = \mu ZT / (\rho + Z) = \mu T / (1 + \rho/Z)$$

$$= \frac{\mu T}{1 + \rho [T^2/R + 1/j\omega L]}$$

$$= \frac{40 \times 3}{1 + 3 \times 10^4 \left[\frac{9}{5 \times 10^6} + \frac{1}{2\pi f \times 30j} \right]}$$

$$= \frac{120}{1.54 - (500j/\pi f)}$$

$$\text{If } f = 100, m = \frac{120}{1.54 - (5j/\pi)}$$

$$= \frac{120}{1.54 - 1.592j}$$

$$= \frac{120}{\sqrt{(1.54^2 + 1.592^2)}} = 54.18 \text{ Ans.}$$

$$\text{If } f = 10\,000, m = 120 / (1.54 - 0.159j) \approx \frac{120}{1.54}$$

$$= 77.93 \text{ Ans.}$$

40. (a) 2.3 mA.; 1.38 V.; (b) 0.408 mA.; 0.245 V.; 0.707; 1.414.
 41. 0.913 A. 42. The latter, which gives 14.3 compared with 13.3.

43. 4.43. 44. 22.1. 45. 0.87 W. 46. 1.97 mA./V. 47. 190; 33 000 ohms; 5.8 mA./V.; 3.3 W.; 0.67%. 48. (a) 20.3; (b) 5.0. 50. 18.3. 51. (a) 5.32; (b) 4.67. 52. 79.3 db. 53. 7. 54. 126.7 $\mu\mu\text{F}$.; 25.9; 21.4.

EXAMPLES 16

7. 10 kW. 11. 0.18 mH. 17. Now $\delta = \pi R\sqrt{C/L}$

$$\begin{aligned} \therefore \text{Fractional amplitude} &= \frac{I_h}{I_1} \cdot R\sqrt{\frac{C}{L}} \cdot \frac{1}{h^2 - 1} \\ &= \frac{1}{2} \times 5\sqrt{\left(\frac{4 \times 10^3}{10^9}\right)} \cdot \frac{1}{4 - 1} \\ &= \frac{5 \times 2}{2 \times 10^3 \times 3} = \frac{1}{600} \text{ Ans.} \end{aligned}$$

18. 40.6%; 6.32 kW.

23. Now alteration in resistance = gM/C

$$\text{But } \mu = g\rho$$

\therefore Alteration in resistance = $\mu M/\rho C$

$$\begin{aligned} &= \frac{10 \times 2 \times 10^{10}}{5 \times 10^4 \times 10^5 \times 3} = \frac{4}{3} \\ &= 13\frac{1}{3} \text{ ohms. Ans.} \end{aligned}$$

25. 123 μH .; 822 $\mu\mu\text{F}$. 26. 5 mH.; 0.006 μF . 27. (1) $M = 30 \mu\text{H}$. (2) $M = 32.7 \mu\text{H}$. 28. 0.402 of coil from cathode end. 29. 84.1 μH . 30. 2.5 μH .; 822 kc./s.

EXAMPLES 19

8. 1.6 to 1.

$$\begin{aligned} 9. \quad \text{Now } i &= \frac{e^2}{2} \cdot \frac{d^2i}{dv^2} \\ &= E^2/2(1 + m \cos nt)^2 \cos^2 \omega t \times 2c \\ &= E^2c(1 + m^2 \cos^2 nt + 2m \cos nt)(\cos^2 \omega t) \\ &= E^2c[1 + (m^2/2)(1 + \cos 2nt) \\ &\quad + 2m \cos nt][(1 + \cos 2\omega t)/2] \\ \therefore \text{Audio output} &= (cE^2/2)[(m^2/2) \cos 2nt + 2m \cos nt] \\ &= cE^2[(m^2/4) \cos 2nt + m \cos nt] \text{ Ans.} \end{aligned}$$

$$\begin{aligned} 10. \quad \text{Now } V &= \frac{\mu\omega LV_g}{\rho_2 \sqrt{[1 + \omega^2 L^2(1/\rho_1 + 1/\rho_2)^2]}} \\ &= \frac{10 \times 2\pi \times 10^3 \times 10 \times 3}{10^4 \sqrt{\left[1 + 4\pi^2 \times 10^6 \times 10^3 \left(\frac{1}{5 \times 10^4} + \frac{1}{1 \times 10^4}\right)^2\right]}} \\ &= \frac{60\pi}{\sqrt{(1 + 4\pi^2 \times 1.44)}} = 24.78. \text{ Ans.} \end{aligned}$$

13. 44 000 ohms. 19. 77.5%. 21. 100 B; 15 kW. 23. 0.88 mA., r.m.s. 25. 14.4 kW. 28. Power in both side bands = 0.18 power in carrier. 29. 71.3%. 30. 64.8%. 31. 6.25%.

EXAMPLES 20

14. 8.94 kV.

EXAMPLES 22

8. 4.71 volts.

EXAMPLES 23

2. 4.115 decibels.

EXAMPLES 24

2. Now $F = 300\sqrt{W/d}$
 $= \frac{300\sqrt{100}}{100 \times 1000}$ volts per metre
 $= (3/100) \times 10^6 \mu\text{V./metre}$
 $= 3 \times 10^4 \mu\text{V./metre. Ans.}$

3. 0.00076.

4. $1/3 \times 10^{-5}$ lines per cm².

EXAMPLES 25

3. 2.85 kW. 6. Efficiency is increased to 3.3 times.

8. 57 kW.; 25.1%. 9. 100 ohms.

10. 74 $\mu\text{H.}$; 950 $\mu\mu\text{F.}$; 500 m.; 0.396 kW.

11. (i) Radiation resistance $r = 1.76 \times 10^{-6} \lambda^2 f^2$
 $= (1.76/10^8) (200 \times 3048 \times 480)$
 $= 15.07$ ohms. *Ans.*

(ii) Power radiated $= I^2 r$
 $= 50^2 \times 15.07$ watts
 $= 37.68$ kW. *Ans.*

(iii) Efficiency $= (15.07/50) \times 100\%$
 $= 30.14\%$. *Ans.*

13. 50 kW.; 174 kV. 14. 0.158 ohm. 15. 13.9%. 16. 33%.

EXAMPLES 26

1. 29°. 4. 23°. 5. 15° 18'. 6. 4.5 db.; 3 db. 7. If the comparison field = F., that due to the combination is (1) 2 F.; (2) 0; (3) 1.956 F. 8. (a) 0.707; (b) 0.209. 10. 6 db.

EXAMPLES 27

1. 96.5 mV. 2. (1) 80 mV.; (2) 2.51 mV.

3. Now $\lambda = 1885 \sqrt{LC} \therefore 300 = 1885 \sqrt{L \times 250 \times 10^{-6}}$

$$L = \left(\frac{300}{1885} \right)^2 \times \frac{10^6}{250} = 101.4 \mu\text{H.}$$

- ∴ Inductance of loading coil = 81.4 μH.
 Reactance of loading coil = $2\pi \times 10^6 \times 81.4 \times 10^{-6}$
 = 511.6 ohms

If h is the effective height in metres

$$\text{Then e.m.f.} = 5h \text{ mV.}$$

$$\text{current} = 5h/25 = h/5 \text{ mA.}$$

$$\text{P.D. across coil} = (h/5) \times 511.6 = 1000$$

$$\therefore h = 1000/102.32 = 9.77 \text{ metres. Ans.}$$

5. 31.07 volts. 6. 21.76 mA. 7. 19.6 V.

EXAMPLES 28

1. 1.32 μA. 3. 0.959 volts.

$$\begin{aligned} 4. \text{ Now } E &= (2\pi FAN/\lambda) \cos \theta \\ &= \frac{2\pi \times 3 \times 10^4 \times 10 \times 0.7071}{10^9 \times 10^3} \text{ volts.} \\ &= 1.33 \mu\text{V. Ans.} \end{aligned}$$

$$\begin{aligned} 6. \text{ Now } &= 1/2\pi\sqrt{LC} \quad \therefore L = 1/4\pi^2 f^2 C \\ &= \frac{10^{12}}{4\pi^2 \times 10^{10} \times 10^3} \text{ henries} \\ &= 100/4\pi^2 = 2.53 \text{ mH. Ans.} \end{aligned}$$

$$\text{Again } E = \frac{2\pi FAN}{\lambda} \cos \theta = e \cos \theta$$

$$\text{Then } I = \frac{e}{Z} \cos \theta \text{ and } E_c = \frac{e}{Z\omega C} \cos \theta$$

$$(i) \quad Z = R; \theta = 45^\circ \quad C_1 = 1000 \mu\text{F.}$$

$$\therefore E_c = \frac{e}{\omega RC_1 \sqrt{2}}$$

$$(ii) \quad \cos \theta = 1 \quad C_2 = 990 \mu\text{F.}$$

$$\text{Now } \omega L = \frac{1}{\omega C_1} = \frac{10^{12}}{2\pi \times 10^5 \times 10^3} = 1591.5$$

$$\frac{1}{\omega C_2} = \frac{10^{12}}{2\pi \times 10^5 \times 990} = 1607.5$$

$$\therefore X = 16$$

$$\therefore E_c = \frac{e}{\omega C_2 \sqrt{R^2 + 16^2}} = \frac{e}{\omega RC_1 \sqrt{2}}$$

$$\therefore \frac{\sqrt{R^2 + 16^2}}{R} = \frac{C_1 \sqrt{2}}{C_2} = \frac{1000 \sqrt{2}}{990}$$

$$\therefore R = \frac{16}{\sqrt{1.0406}} = 15.6 \text{ ohms. Ans.}$$

7. 0.316 volts. 10. 0.257 V.; 0.272 mA. 11. 2.09 mV.
 12. 7.07 mA. 13. 0.227 mV. 14. 197.3 μ V. 15. 87.6 μ V.
 16. 2.96 mV. 17. 0.048 V./m. 18. 0.568 V.

EXAMPLES 29

1. 377 metres; 1 000 μ H. 2. 443 μ μ F.; 28.6 μ H. 3. 2.08 mH.
 4. 1.523 mH.; shunt capacitance of 0.0102 μ F. 5. 314 μ H.;
 49.2 μ μ F.

EXAMPLES 30

1 $11^\circ 28'$.

EXAMPLES 31

1. 7.6 lb.

3. Wind load $= \frac{30 \times 1 \times 1\ 200}{12} = 3\ 000$ lb.

Safe tension $T = \sqrt{(22\ 400^2 - 3\ 000^2)} = 22\ 198$ lb.

Now $w = 2 + \frac{9}{6} = 3.5$ lb./ft.

\therefore Sag $= w l^2 / 8T = \frac{3.5 \times 1\ 200 \times 1\ 200}{8 \times 22\ 198}$
 $= 28.4$ feet. *Ans.*

4. 250. 6. 25.2 ft. 7. 1 265 lb. 8. 44 lb.; 7.36 in.; 8.36 in.
 9. 15 590 lb.-ft.

EXAMPLES 35

6. Now $U = v/\omega$
 $= 10^8 E / A\omega$, since $E = A v / 10^8$
 $= 10^8 \omega L I / A\omega$ since $E = \omega L I$

\therefore Amplitude $= \frac{10^8 \times 0.2 \times 10 \times 1.414}{1\ 000 A} = \frac{0.2828 \times 10^6}{A}$

Now $A = B l = 5\ 000 \times 3 \times 10^4$

\therefore $U = \frac{0.2828 \times 10^6}{5 \times 10^3 \times 3 \times 10^4} = \frac{0.2828}{150}$ cm.
 $= \frac{0.2828}{15}$ mm. = 0.0189 mm. *Ans.*

12. Telephone receiver current would be 2.97 times speaker current
 13. 100 ohms; 0.16 H. 15. 989 c/s. 16. $A = 6.37 \times 10^6$ dynes/
 amp.; $r = 253$ dynes/cm./sec.; $m = 1.06$ gm.; $s = 41.7 \times 10^6$
 dynes/cm.

EXAMPLES 36

6. $\sqrt{(R + j\omega L)(j\omega C)}$; $1/\pi\sqrt{LC}$.

7. Shunt resistance, 421 ohms; each series resistance, 313 ohms.

8. 6.91 nepers.

9. Each series element = 31.8 mH.
 Shunt element = 0.177 μ F.
10. Series, 294 ohms; shunt, 12 ohms.
11. Each series element of a T-section, 0.0133 μ F; shunt element, 2.39 mH.
12. 95.5 mH.; 0.265 μ F.
13. $Z_x = \sqrt{4z_1^2 + z_1z_2}$.
14. (a) Each series element, 95.5 mH.
 Shunt element, 0.53 μ F.
 (b) Series element, 191 mH.
 Each shunt element, 0.265 μ F.
15. (a) Each series inductance, 120 mH.
 Shunt capacitance, 0.667 μ F.
 (b) Series inductance, 240 mH.
 Each shunt capacitance, 0.333 μ F.
16. (a) Inductance of each series arm, 72 mH.
 Inductance in shunt arm, 64 mH.
 Capacitance in shunt arm, 0.4 μ F.
 (b) Inductance in series arm, 144 mH.
 Capacitance in series arm, 0.178 μ F.
 Capacitance of each shunt arm, 0.2 μ F.
- 17.

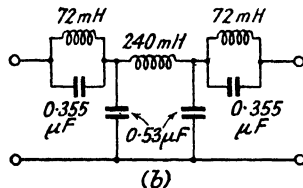
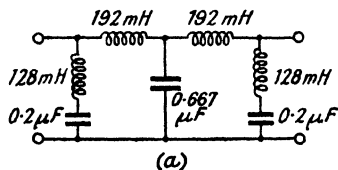

18. (a) Each series element, 0.133 μ F.
 Shunt element, 23.9 mH.
 (b) Series element, 0.0663 μ F.
 Each shunt element, 47.7 mH.
19. (a) Each series capacitance, 0.333 μ F.
 Shunt inductance, 60 mH.
 (b) Series capacitance, 0.167 μ F.
 Each shunt inductance, 120 mH.
20. (a) Capacitance of each series arm, 0.556 μ F.
 Capacitance in shunt arm, 0.625 μ F.
 Inductance in shunt arm, 100 mH.
 (b) Inductance in series arm, 225 mH.
 Capacitance in series arm, 0.278 μ F.
 Inductance of each shunt arm, 200 mH.

21.

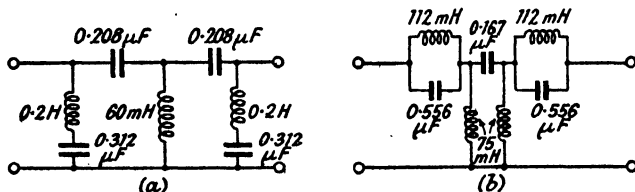

22. (a) Each series inductance, 31.8 mH.
Each series capacitance, 53.9 μF .
Shunt inductance, 9.7 μH .
Shunt capacitance, 0.177 μF .
- (b) Series inductance, 63.7 mH.
Series capacitance, 27 μF .
Each shunt inductance, 19.4 μH .
Each shunt capacitance, 0.088 μF .
23. (a) Each inductance in series arm, 35.4 mH.
Each capacitance in series arm, 0.4 μF .
Inductance in shunt arm, 49.7 mH.
Capacitance in shunt arm, 0.283 μF .
- (b) Inductance in series arm, 70.7 mH.
Capacitance in series arm, 0.2 μF .
Each inductance in shunt arms, 99.5 mH.
Each capacitance in shunt arms, 0.141 μF .
24. 712 c/s. 25. 14 db. 26. 12 db. 27. 19.1 db.; 135 ohms.
28. Series resistance, 2970 ohms; each shunt resistance, 733 ohms.
29. Series elements, 245 ohms; shunt element, 121 ohms.
30. Shunt resistance, 242 ohms; each series resistance, 982 ohms.

EXAMPLES 37

1. 424.6 A.

EXAMPLES 38

1. Now $10 \log (W_2/W_1) = 16 = 20 \log (V_2/V_1)$
 $\therefore \log V_2/V_1 = 0.8$
 $V_2/V_1 = 6.31$. Ans.
2. 633 ohms; 4 decibels. 4. 1 092 ohms at $\omega = 5 000$.
5. 548 ohms.
8. Two quarter-wave lines, one having $d = 0.05$ in., $s = 18$ in. in series with the antenna; the other, $d = 0.5$ in., $s = 5$ in.
10. 600 ohms; $S/r = 18$. 11. A transformer of turns ratio 1.47.
12. 600 ohms; parallel-wire line with $S/r = 34.4$. 13. 83.1 ohms.
14. $100/\sqrt{30^\circ}$ ohms. 15. 72.4 ohms.

EXAMPLES 39

3. 102 μH .; 108 πH . 4. 6.3 μH . 5. 7 μF . 6. 1.3 μF .

