

BIRLA CENTRAL LIBRARY
PILANI (RAJASTHAN)

Call No. 621.319
T570

Accession No. 33178

OUTDOOR HIGH VOLTAGE SWITCHGEAR

BY

R. W. TODD, A.M.I.E.E., Assoc.A.I.E.E.

AND

W. H. THOMPSON, A.M.I.E.E.

WITH A FOREWORD BY

A. P. M. FLEMING, C.B.E., M.Sc. M.I.E.E.



LONDON
SIR ISAAC PITMAN & SONS, LTD.

1937

SIR ISAAC PITMAN & SONS, LTD.
PITMAN HOUSE, PARKER STREET, KINGSWAY, LONDON, W.C.2
THE PITMAN PRESS, BATH
PITMAN HOUSE, LITTLE COLLINS STREET, MELBOURNE

ASSOCIATED COMPANIES

PITMAN PUBLISHING CORPORATION
2 WEST 45TH STREET, NEW YORK
205 WEST MONROE STREET, CHICAGO

SIR ISAAC PITMAN & SONS (CANADA), LTD.
(INCORPORATING THE COMMERCIAL TEXT BOOK COMPANY)
PITMAN HOUSE, 381-383 CHURCH STREET, TORONTO

FOREWORD

OF the many links between the generation of electrical energy and its use by the community, none is of greater or more growing importance than that which is concerned with the means of its control in the form of switchgear and circuit-breakers. The demands on this link have altered entirely in magnitude and character with the advent of the interlinkage of large power systems and the use of increasingly higher voltages. In magnitude of operation this link may have to deal with the continuous flow or the disruption of flow of millions of kilowatts, and within a decade or so the problem has changed from being one concerned with the mere mechanical opening of a circuit to one in which the most scientific study has been applied, with the corresponding evolution of mechanisms that will operate with extreme rapidity, precision and reliability, commensurate with the contingent liabilities that failure of operation of large modern power systems involves.

In this evolution, increase in scientific knowledge arising from an understanding of the ionization of gases and the development of modern methods of measuring electrical quantities of a rapidly fluctuating character, have been factors of major importance. Notable in the latter respect is the employment of the cathode ray oscillograph, which has been brought to such a marvellous state of development.

Coupled with a knowledge of the most modern developments in electro-physics, the modern switchgear and circuit-breaker designer needs a very wide range of mechanical engineering knowledge and experience, as he has to evolve mechanisms which will operate with great speed, accompanied by conditions

involving considerable pressures and the possibilities of the development of very great forces.

This book embodies in a marked degree these wide and varied conditions as revealed by the knowledge of designers, who have had life-long experience in this field of engineering under conditions where the most modern scientific research, the most up-to-date full power testing facilities, and access to the widest range of operating experience are encountered. Within the compass of one volume the Authors have achieved a very notable contribution to the literature of the subject.

A. P. M. FLEMING.

PREFACE

THIS work is a collection of data and technical information acquired by the authors during many years active experience in the design of High Voltage Switchgear.

There are books already published on Switchgear which deal in part with High Voltage Gear, but this book purports to deal solely with this important branch of Electrical Engineering.

The authors are indebted to many people and firms for help they have received in the preparation of this volume. Their particular thanks are due to—

Mr. J. S. Peck and Mr. A. P. M. Fleming for their encouragement and also for permission to publish certain technical data.

Mr. W. A. Coates for his help in reading over the MSS. and for his constructive criticism.

Dr. Allibone, who advised and helped with the chapters on Arc Phenomena and Impulse Technique.

Mr. T. W. Ross for his assistance in the section on protective gear.

Mr. D. R. Davies for his advice on Metal Clad Switchgear.

Mr. B. L. Goodlet and Mr. C. Dannatt for their help.

Mr. P. Cooper for his information on porcelain manufacture.

The staff of the High Voltage Switchgear Section at Metropolitan-Vickers Electrical Co., Ltd., for many services.

The Metropolitan-Vickers Electrical Co., Ltd., for permission to publish the work, and for many facilities they have offered to this end.

The following firms who have supplied photographs, drawings, and data of their apparatus and have consented to their publication—

The British Thomson-Houston Co., Ltd., Ferguson Pailin, Ltd., A. Reyrolle & Co., Ltd., Taylor Tunnicliff & Co., Ltd., A.E.G. Co.

We have drawn lavishly from the works of many eminent people in the electrical field, and, whilst we have acknowledged these gentlemen in the bibliography at the end of each chapter, we gladly add to that our thanks.

R. W. T.

W. H. T.

CONTENTS

	PAGE
FOREWORD	v
PREFACE	vii

CHAPTER I

INTRODUCTION	1
------------------------	---

CHAPTER II

DIAGRAMS OF SCHEMES AND STATION LAY-OUTS	5
--	---

Station lay-outs—Outdoor mounting—"High" type stations—"Low" type stations—National specifications dealing with outdoor stations—Choice of a suitable site for an outdoor station—Steel structures—Tension loading—Deadweight loading—Windage—Isolating switch operation—Erection and maintenance loading—Electrical clearances—Stress diagram—Material—Design—Factor of safety against overturning—Foundations—Stresses—Slenderness ratio—Galvanizing—Marking—Galvanizing *versus* paint—Reinforced concrete structures—High structures—Low structures—Indoor mounting

CHAPTER III

ELECTRICAL PORCELAIN AND ITS MANUFACTURE	43
--	----

Porcelain manufacture—Raw material—Comparing the body—Forming—Throwing and turning—Jollying—Casting—Drying—Glazing—Firing

CHAPTER IV

THE DESIGN AND TESTING OF PEDESTAL INSULATORS	53
---	----

General electrostatics—The dielectric field—Specific inductive capacitance—Shape of the electrodes—Cap and pin-type insulators, shaping the body—Shaping of rain sheds—Equipotential surfaces—Diffraction—Spacing of rain sheds—Spark-over values of pin-type insulators—Puncture values of cap and pin-type insulators—Weather conditions—Rain—Precipitation—Resistivity—Fog—Humidity—Wind—Atmospheric pressure and temperature—Fouling—Deposits—Types of deposits—Effect of electrical forces on insulator fouling—Insulators in fouled positions—Protected leakage path type—Leakage resistance form factor—Disadvantages of protected path insulators—Rain-washed insulators—Disadvantages of rain-washed insulators—Choice of insulators for fouled conditions—Mechanical strength and manufacture—Roughing or knurling—Cementing—Shape of sections—Mechanical design of insulators—Testing of porcelain insulators—Variations in test results—Puncture tests—Mechanical tests—Porosity tests—Temperature cycle tests—High frequency and impulse tests—Impulse testing—Designation of wave forms—Positive and negative values—Maximum and minimum impulse spark-over values

CONTENTS

CHAPTER V

	PAGE
AIR-BREAK SWITCHES FOR LOAD-BREAKING AND ISOLATING PURPOSES	99

Isolating switches—Light load-breaking switches—Load-breaking switches—Pole operated isolating switch—Gang-operated switches—General details of switches—Bases—Rotating insulator bearings—Break-jaw contacts—Mechanical operation—Dimensions—Pole centres for isolating switches and load-breaking switches—Phase centres for load-breaking switches—Load-breaking capacity of outdoor air-break switches—Arc breaking in air—Magnetic blow out—Convection—Wind—Load-breaking at commercial power factor—Breaking line charging currents—Earth switches

CHAPTER VI

CONTACT PRESSURE AND TEMPERATURE RISE	123
---	-----

CHAPTER VII

ARC INTERRUPTION PHENOMENA	127
--------------------------------------	-----

Theory of arc interruption—Arc voltage—Arc energy—Multiple breaks in series—Arc energy (*continued*)—The gas bubble—Thermal ionization—Energy balance—Gas volume and pressure—Head of oil—Tank pressure

CHAPTER VIII

RESTRIKING VOLTAGE AND BREAKING CAPACITY	172
High frequency effects on restriking voltage—Breaking capacity	

CHAPTER IX

OIL CIRCUIT-BREAKER DESIGN	172
--------------------------------------	-----

General features—Oil—Condensation—Vermin—General construction—Pole interconnecting gear—Tanks—Floor mounting—Maintenance—Oil circuit-breaker contacts—Butt type—Finger and wedge type—Plug and socket type—Arc control devices—Theory of operation of the plain explosion pot—Oil-blast explosion pot—The de-ion grid contact—Cross-jet explosion pot—The turbulator contact—Electrical clearances for oil circuit-breakers—Air clearances—Oil clearances—Corona shields and stress distributors—Insulation barriers—Oil—Recommended oil clearances—Impurities in oil—Surface creepage distances—Contact lifting mechanisms—Lever and toggle mechanism—Rack and pinion mechanism—Arcs control mechanism—Dashpots—The oil dashpot—The spring buffer—The oil-spring dashpot—Operating mechanisms for oil circuit-breakers—Dirt and damp—Solenoid operating mechanism—Operating coils—Solenoid mechanism: Metropolitan-Vickers; Ferguson Pailin—Motor-operated mechanisms—Flywheel type—Spring type—Centrifugal motor type—Motor-operating mechanism—British Thomson-Houston—Compressed air operated mechanism

CONTENTS

xi

CHAPTER X

	PAGE
BUSHING INSULATORS	263
Porcelain bushing—Condenser type bushing—The oil-filled bushing—The voltage tap—Design data—Comparison of bushings—Test methods—Schering bridge	

CHAPTER XI

BUS-BARS, CONNECTIONS AND THEIR FITTINGS	282
Strained conductors—Tension insulators—Tubular conductors—Wind pressure—Vibration—Semi-strained conductors—Terminals	

CHAPTER XII

LIGHTNING SURGE PROTECTION	294
Lightning—Travelling waves—Reflection—The lightning arrester function—Types of arresters—The auto-valve arrester—The Thyrite arrester—The Ferranti surge absorber—Application of arresters—Interference—Arcing ground suppressors—Choke coils—Co-ordination of insulation, and co-ordinating gaps—Humidity—Relative air density—Rainfall—Time lag	

CHAPTER XIII

OUTDOOR HIGH VOLTAGE FUSES	342
The carbon tetra-chloride fuse—The “Quenchol” fuse—The oil-blast fuse—The “Expulsion” fuse	

CHAPTER XIV

RELAY PROTECTIVE GEAR	348
The Translay system—Impedance system; definite impedance relay—Impedance/time relay—Lock-in system—Split-pilot system—Ratio-balance system—Interlock system—Application of protective systems to e.h.v. schemes—Some typical protective systems—The “One Switch” station; Impedance system of protection—The “Three Switch” station; Impedance and lock-in protective systems—The “Mesh” type station—Restricted earth fault protection—Parallel feeder protection—Bushing-type current transformers	

CHAPTER XV

AUXILIARY WIRING AND MULTI-CORE CABLES	388
Cables for small wiring—Multicore cable—Multicore cable schemes—D.C. cables for solenoid coils—Terminal boards and auxiliary switches	

CHAPTER XVI

	PAGE
METAL CLAD SWITCHGEAR	392
66 kV. metal clad equipment—Single-break vertical metal clad equipment—132 kV. metal clad equipment	

CHAPTER XVII

MODERN CIRCUIT-BREAKER DESIGN AND FUTURE TREND .	409
Expansion circuit-breakers—Air-blast circuit-breakers—The impulse type oil circuit-breaker—Future trend—Automatic reclosing	
INDEX	425

INSETS

CATHODE RAY OSCILLOGRAM RECORD OF AN OIL CIRCUIT-BREAKER CLEARING A THREE-PHASE SHORT CIRCUIT <i>Frontispiece</i>	
FIG. 19. THE "THREE CIRCUIT-BREAKER" TYPE OF STATION	18
FIG. 82. OSCILLOGRAM OF RUPTURING TEST	117

OUTDOOR HIGH VOLTAGE SWITCHGEAR

CHAPTER I

INTRODUCTION

THE term "high voltage" used in the title of this book is intended to refer to apparatus for 33 kV. and upwards. The term "extra high voltage" has been avoided because present convention applies this title to voltages of 3 000 and above. The obvious inadequacy of this has influenced the authors to abandon the adjective "extra."

The transfer of electrical power by means of high voltage outdoor transmission is not new. Schemes for this purpose have been operating for many years in a satisfactory manner in all parts of the world. Outdoor switchgear for the control of the lines and transformers for such schemes has been installed and operated under climatic conditions between the abnormal cold of Russia and the humid heat of India.

The first few such schemes to be put into practical use were designed and installed in America. This is perhaps understandable, as the geography of that country gives rise to the necessity for a scheme that will transmit electrical power over long distances. The British Grid has demonstrated that high voltage transmission can be applied with advantage in a comparatively small country for the interlinking of generating and distribution stations.

A similar example, earlier than the British Grid, is that of New Zealand.

The use of outdoor high voltage transmission in Great Britain is new, but the same cannot be said of the products of British manufacturers of high voltage switchgear. At least two firms in England have been making this class of apparatus, for use abroad, since 1921.

Although this book is based on British practice, data on American and European designs have been included.

2 *OUTDOOR HIGH VOLTAGE SWITCHGEAR*

In all branches of engineering, technical and practical information is necessary before a useful knowledge of the subject can be obtained, and in the chapters that follow an endeavour has been made to set out the technical and practical information in what is believed to be the most useful manner. There are instances where the treatment is to some extent applicable to low voltage as well as to high voltage. Two examples of this are the chapters on "Electrical Porcelain and its Manufacture" and "Arc Interruption Phenomena."

Information appertaining to low voltage switchgear has, however, been kept to a minimum.

The complete equipment of a high voltage switching station includes a varied collection of apparatus which requires specialized knowledge for its design and arrangement. The reader is first introduced to the general diagrams of schemes that may be used for a switching station, the choice of suitable sites, and the lay-outs of stations themselves.

Having dealt with what may be termed the general engineering portion of the subject, chapters on detail subjects follow.

Because high voltage practice is mainly a question of insulation, and because porcelain is the principal solid insulating material used, the manufacture of this important material is dealt with in the first chapter on apparatus.

Porcelain has been used for low voltage switchgear insulators for many years. The comparative smallness of such insulators has enabled large safety factors to be obtained at low cost. The design and manufacture of high voltage porcelain is, however, exacting, and the skill of the potter is in this case more severely taxed than in any other field of electrical porcelain manufacture.

Some of the porcelains used in high voltage work are larger than anything that has been previously made in this medium.

In order to keep the costs within reason it is necessary to design to a known safety factor and so to proportion the insulators that the maximum use is made of the material included in their make up.

The type of insulator used on transmission lines has been fully treated elsewhere, and is therefore considered only in brief in this book. Its use in outdoor stations is to support bus-bars and long connections.

Chapter IV deals mainly with pedestal insulators for use with switchgear; many of the principles explained, however, apply

to transmission line insulators. The designer's chief problem is common to all outdoor insulators, i.e. the prevention of arc-over caused by the accumulation of dirt and moisture upon the porcelain surfaces.

The complete solution of this problem has not as yet been reached, and insulators having arc-over values many times the working voltage on which they are used is common practice. Much can, however, be done by the application of correct methods in design. The present situation has been summarized by Prof. W. M. Thornton, who made the following statement in his presidential address before the I.E.E.

"It is not too much to say that if a robust insulating, weather resisting covering material should ever be discovered on which moisture films could not form or be maintained so that surface flash-over could not occur, high-tension insulator design would be entirely changed. Meanwhile the world cost of guarding against flash-over and of maintaining the insulation of overhead lines must be reckoned in millions of pounds a year."

Air-break switches and isolating switches provide the principal mechanical problems in connection with pedestal insulators. Both these types of switches are similar in appearance and are therefore liable to be confused. They perform duties which differ widely in character. The simple and somewhat infrequent service rendered by both types is apt to deprive them of the careful consideration they deserve. Their service and detail design are dealt with in Chapter V.

Among the various pieces of apparatus necessary to complete a switching station the circuit-breaker is undoubtedly the most important.

Although the actual constructional design of a circuit-breaker involves mechanical knowledge, the main problems are electrical. In order to appreciate fully these electrical requirements, a knowledge of arc phenomena and the conditions prevailing during electrical short circuit are necessary. These matters are dealt with at some length in the chapters preceding those on circuit-breaker design.

Whereas lightning protective apparatus is used for the purpose of protecting the system from the abnormal voltages induced by storms, relay protective gear ensures the isolation of faulty apparatus or defective transmission lines.

As it is essential that all healthy parts of the system should

4 *OUTDOOR HIGH VOLTAGE SWITCHGEAR*

be left in circuit during such operations, correct discrimination by the tripping relays is necessary. High voltage networks present new problems in this connection due to the long lengths of transmission lines used, and the frequent interconnection of power stations. Several protective systems designed for such service have been developed and a number of the more important arrangements are described and illustrated. No attempt has been made to include every known system of protection.

There is a distinct tendency both in America and Europe to depart from the conventional type of oil circuit-breaker. The new designs so far developed can claim reductions in operating time and either a saving in the quantity of oil contained, or its complete elimination.

Three different types of such circuit-breakers are described in the closing chapter, together with notes dealing with the possible future trend in high voltage switchgear practice.

BIBLIOGRAPHY

Prof. W. M. Thornton, *J.I.E.E.*, Jan., 1935.

CHAPTER II

DIAGRAMS OF SCHEMES AND STATION LAY-OUTS

THE following symbols are used in the diagrams and drawings illustrating this chapter.

- O.C.B.* = Oil circuit-breaker.
- I.S.* = Isolating switch.
- T* = Transformer.
- B.B.* = Bus-bars.
- S.I.* = Strain insulator unit.
- P.I.* = Post insulator unit.
- A.B.S.* = Air-break switch.
- A* = Alternator.
- F* = Fuse.

High voltages are used only when a transfer of power is to be made that would be either impossible or uneconomical at generating voltage. Such conditions are usually created by one or more of the following requirements—

(a) An abundant supply of potential power such as water, coal, or even peat may be available at a location which is many miles from a district or districts where it can be usefully employed. In such a case a generating station is built at the source of power and the transfer made via high tension transmission lines.

(b) A power station having a local supply to maintain may increase its load by installing high voltage feeders to one or more outlying districts.

(c) The interconnection of a number of large generating stations situated at varying distances from each other. Such a scheme enables the most efficient stations to run at an improved load factor, the less efficient plant being used only during heavy load periods. The number of stand-by generating sets can be reduced, and an additional insurance against failure of supply obtained. The British Grid can be cited as an example of such a scheme.

The station diagram chosen will depend on which of the above requirements have to be met. It will be further influenced by the capital expenditure permissible, the degree of flexibility required, and the importance placed on maintenance of supply.

Most of the arrangements used on lower voltage schemes are utilized ; ring mains, single, duplicate and radiating feeders, single and double bus-bars, etc., all have their place. The application of such circuits is generally known. There are, however, occasions when circumstances make possible certain economical arrangements that are peculiar to high voltage distribution. Several schemes of this type will be dealt with and compared with the more conventional methods.

The requirements outlined under (a) will mean that the whole of the power generated, except for a station auxiliary

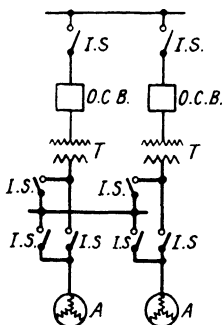

FIG. 1

DIAGRAM OF SWITCHING STATION, SHOWING LOW TENSION TRANSFER ISOLATORS

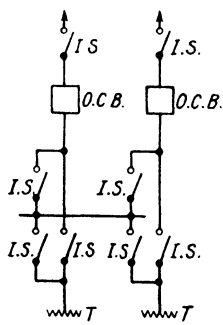

FIG. 2

DIAGRAM OF SWITCHING STATION, SHOWING HIGH TENSION TRANSFER ISOLATORS

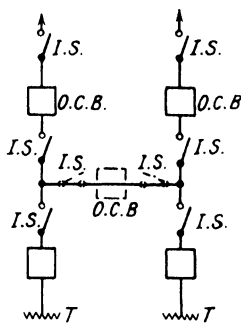

FIG. 3

CONVENTIONAL DIAGRAM FOR CONNECTING TWO TRANSFORMERS AND TWO FEEDERS

supply, will be transmitted at high tension. In such cases saving can be made by switching each alternator and its step-up transformer as a unit. Synchronizing is carried out by the transmission voltage oil circuit-breaker, thereby dispensing with generator voltage breakers. In large power stations, this saving is considerable, as heavy current large breaking capacity breakers with their complementary equipment are expensive items. The interconnection of the various alternators with any one of the transformers can be accomplished by a series of isolating switches and a stub bus-bar. (Fig. 1.)

A somewhat similar scheme may be used for switching a transformer and an outgoing feeder as a unit, thus halving the number of breakers required. Interlinking by isolators and bus-bars is again possible. (Fig. 2.) Such an arrangement may be used for the requirements specified under (b). The

application is, however, limited, as in many cases transformers are installed of such a capacity that they supply more than one feeder. The cost of installing smaller capacity transformers for each feeder in such cases might be higher than the saving in switchgear.

The capital saved in both the cases described above is offset to some extent by the longer time required for change-over switching during trouble periods. Further, a fault on either of the two items switched as a unit means the disconnection of both. In the case of Fig. 1 the probability of fault in either alternator or transformer is approximately equal, but under

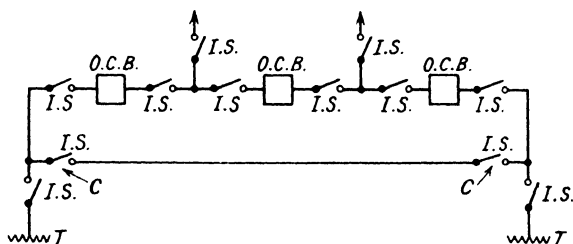

FIG. 4. AN ECONOMICAL ALTERNATIVE TO FIG. 3, USING THREE BREAKERS

the conditions illustrated in Fig. 2 about 90 per cent of the service interruptions will be caused by line troubles.

When circumstances as described in (c) prevail, some form of ring main is usually adopted. A minimum of two transformers at each point is necessary if continuity of supply is essential. The conventional diagram for two transformers and two feeders is shown in Fig. 3. Four or even five breakers and six to eight three-phase isolators are utilized. Fig. 4 illustrates an economical alternative in which three breakers and twelve isolators are necessary. This scheme, which was first introduced by Mr. J. R. Beard, has been extensively used in the British Grid. Special protective gear arrangements are necessary, which are dealt with in Chapter XIV. The normal operating condition of this station is with all breakers and isolating switches closed, except isolators C.

In certain cases, the small load demand at a particular substation in a ring may make a three-breaker arrangement uneconomical. In such cases a compromise can be made by using one breaker situated between the transformer tapping

points, and connected direct in the ring, using air break switches and fuses for transformer control. (Fig. 5.) Such an arrangement has been used with advantage at 33 kV. The protective gear, described more fully in Chapter XIV, functions in such

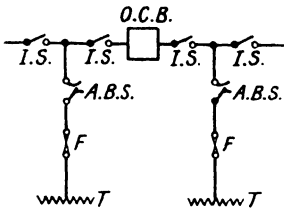

FIG. 5. AN ECONOMICAL ALTERNATIVE TO FIG. 3, USING ONE BREAKER

a manner that the oil circuit-breaker is tripped by a fault on either feeder, and at the same time opens the breaker controlling the low tension side of the transformer connected to the faulty feeder. Thus the trouble is isolated and service maintained through the remaining portion of the ring and the remaining transformer.

The conventional arrangement adopted for the larger types of station which control a number of feeders and transformers is the double-bus scheme shown in Fig. 6. An alternative to this arrangement is shown in Fig. 7. This latter scheme, known as the *mesh type* is a development of the three-breaker station, Fig. 4. On comparing these two diagrams it will be seen that,

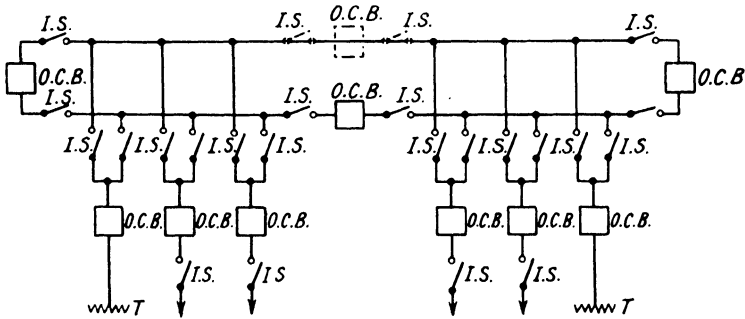

FIG. 6. CONVENTIONAL DIAGRAM FOR A DOUBLE BUS-BAR SWITCHING STATION

provided a suitable physical lay-out has been adopted, a three-breaker station may be extended to a mesh arrangement.

The principal difference between the double-bus and mesh type stations is that the mesh arrangement connects all circuit-breakers together in a complete ring, the feeders and transformers being tapped off between the breakers. The normal running arrangement is with all breakers and isolators in the ring closed. Circuits out of commission are isolated by their

respective isolating switches. Each circuit is fed by two breakers, and maintenance work may be carried out on either of these breakers without closing down the circuit or sacrificing

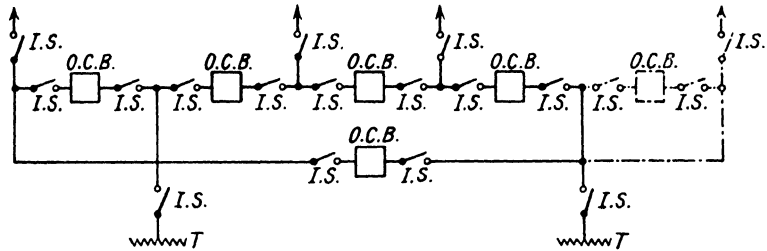

FIG. 7. AN ECONOMICAL ALTERNATIVE TO FIG. 6

its automatic protective features. The protective gear and its connections are so arranged to ensure correct operation for feeder or transformer. In the normal double bus-bar case, maintenance work on a breaker

makes it necessary to close down the particular circuit it controls. This condition can be avoided in two different ways. The first scheme is to provide double breakers for each circuit, Fig. 8, a modification that increases considerably the capital cost. The second arrangement, Fig. 9, adds a by-pass isolator which transfers the circuit to the auxiliary bus-bars, the latter being connected to the main bus-bars via an automatic bus-bar coupling breaker, thereby preserving the automatic protection of the circuit.

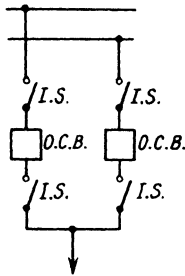

FIG. 8

DIAGRAM OF DOUBLE BREAKER ARRANGEMENT FOR DOUBLE BUS-BARS

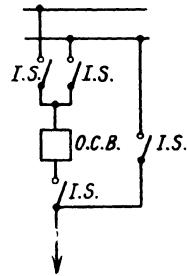

FIG. 9

DIAGRAM OF BY-PASS ISOLATOR SCHEME TO FACILITATE BREAKER MAINTENANCE

Double-bus schemes in any case must of necessity include a bus-bar coupling breaker to enable the bars to be synchronized. In many cases bus-bar sectionalizing breakers in one or both of the bus-bars are included to further aid flexibility. No such additions are necessary with the mesh scheme. Sectionalizing for line charging, fault location or pressure testing is possible with both schemes. In the double bus-bar case, a section of

10 OUTDOOR HIGH VOLTAGE SWITCHGEAR

bus-bar is isolated from the main bars and the feeder in question, together with the necessary transformer connected thereto. In the mesh arrangement, the feeder is connected to its adjacent transformer, the ring being broken either side by isolating switches, the remaining transformer or transformers feeding the remainder of the ring. This scheme is only possible when either one or two feeders are installed for each

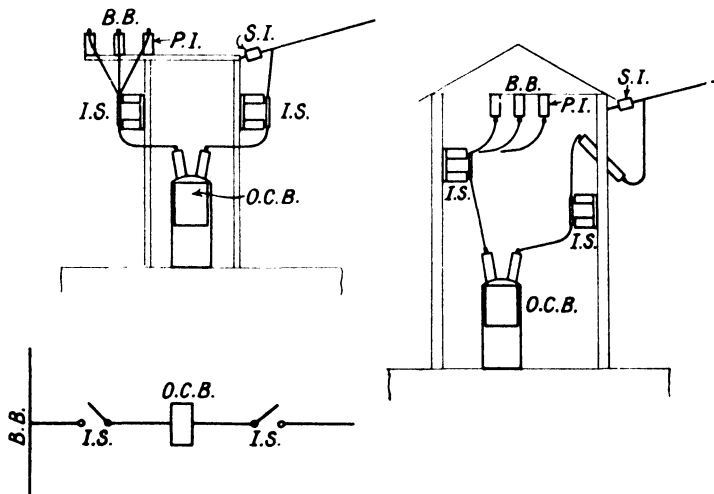

FIG. 10. TWO ARRANGEMENTS SHOWING THE SIMILARITY BETWEEN INDOOR AND OUTDOOR LAY-OUTS

transformer circuit, as adjacent circuits only can be joined together. It is, of course, possible to interconnect any two circuits provided all intermediate circuits have been isolated. In most instances, such a course is impossible. The double bus-bar makes possible the connecting together of any two or more circuits. Thus any one transformer may be connected to any feeder, irrespective of its physical position.

STATION LAY-OUTS

Outdoor Mounting. The designing of high voltage switchgear for outdoor mounting was the logical solution of an economic problem. The large clearances required between phases and to earth, together with the overall size of the apparatus itself, made enclosing buildings an expensive item, particularly at voltages above 66 kV.

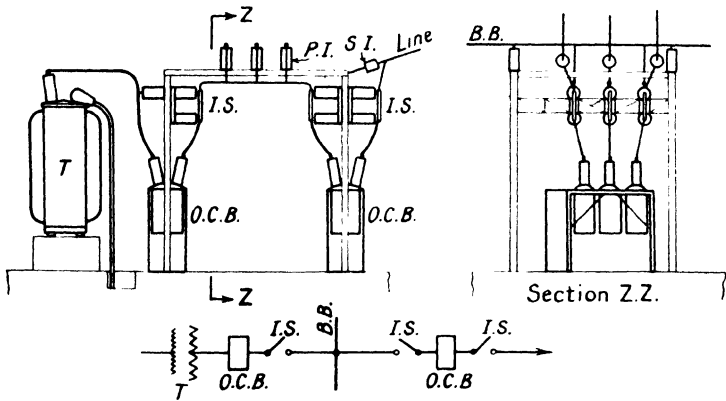

FIG. 11. SINGLE BUS-BAR ARRANGEMENT WITH POLE-OPERATED ISOLATING SWITCHES

Two circuits per bay. Suitable for use up to 66 kV. Girder structure. High type.

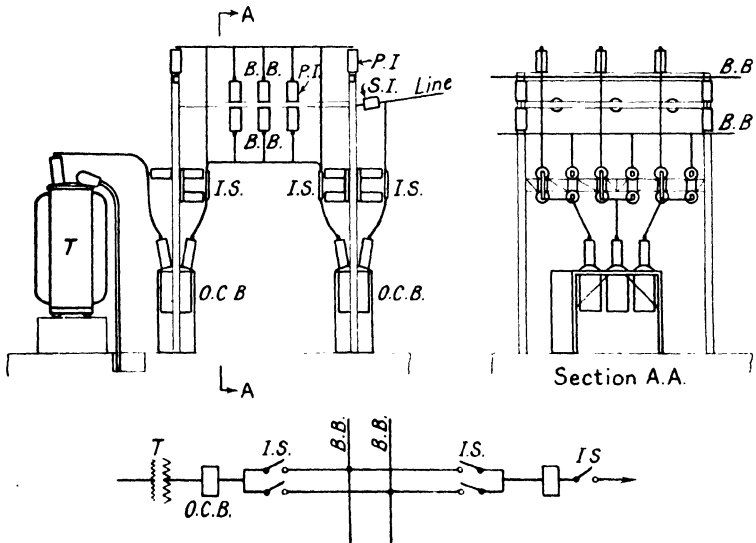

FIG. 12. A SIMILAR ARRANGEMENT TO FIG. 11, BUT ARRANGED WITH DOUBLE BUS-BARS

12 OUTDOOR HIGH VOLTAGE SWITCHGEAR

Investigation proved that only a small percentage of this cost was necessary to make the apparatus suitable for outdoor mounting. Indoor mounting is still resorted to in special circumstances. Such cases will be dealt with later.

“High” Type Stations. Until recent years, practically all

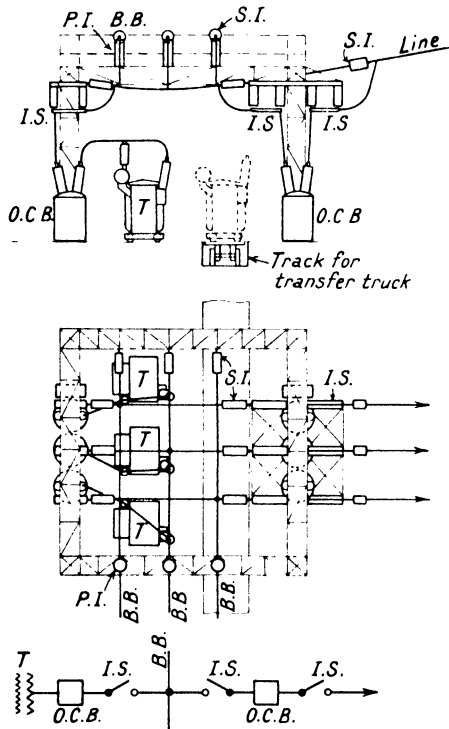

FIG. 13. SINGLE BUS-BAR ARRANGEMENT WITH GANG-OPERATED ISOLATING SWITCHES

Two circuits per bay. Suitable for voltages of 88 kV. and above. Lattice structure. High type.

outdoor stations were constructed on the same general lines. A skeleton steel frame structure was utilized to support the isolating switches, connections, and bus-bar supporting insulators. (Figs. 11 to 15.) This type of arrangement follows closely the lay-out that would be used indoors, as the structure is virtually a skeleton building. (See Fig. 10.) This construction, known generally as the “High” type, is still extensively

used, particularly where floor space is limited and when ground is expensive.

The station arrangements possible are legion: illustrations

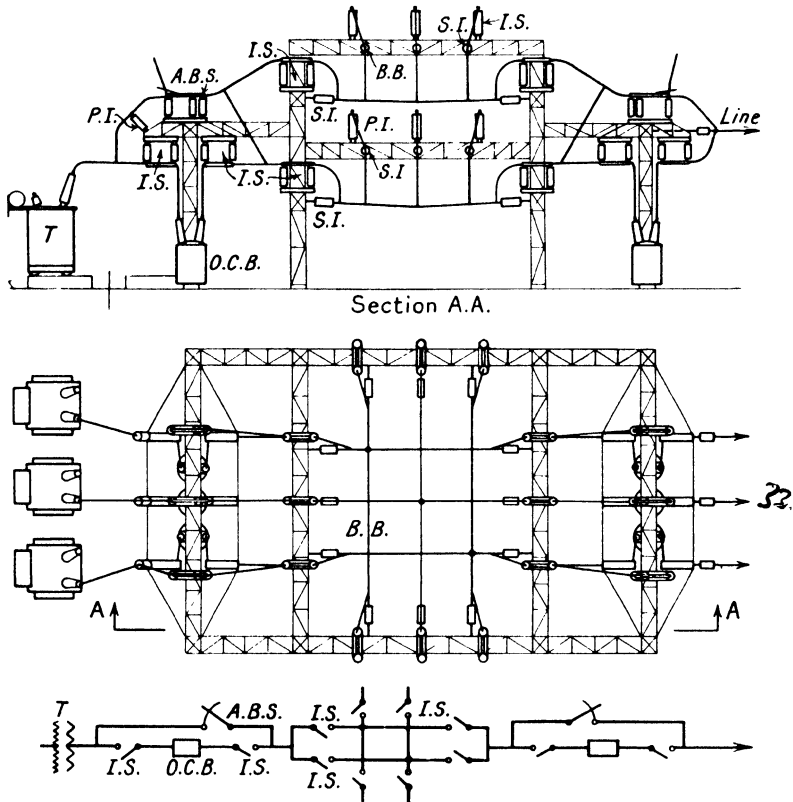

FIG. 14. DOUBLE BUS-BAR ARRANGEMENT WITH GANG-OPERATED ISOLATORS AND AIR-BREAK BY-PASS SWITCHES FOR THE CIRCUIT-BREAKERS

Two circuits per bay. Suitable for voltages of 88 kV. and above. Lattice structure. High type.

are therefore given of key arrangements which may be used in building up complete schemes.

“Low” Type Stations. During the last few years a new principle has been employed in lay-out design.

It was in all probability due to attempts to incorporate two desirable features; firstly, to provide an arrangement in which non-rusting, i.e. ferro-concrete, structures could be

14 *OUTDOOR HIGH VOLTAGE SWITCHGEAR*

utilized in an economical manner, and secondly, to make the maintenance of isolators and insulators safer and easier. The

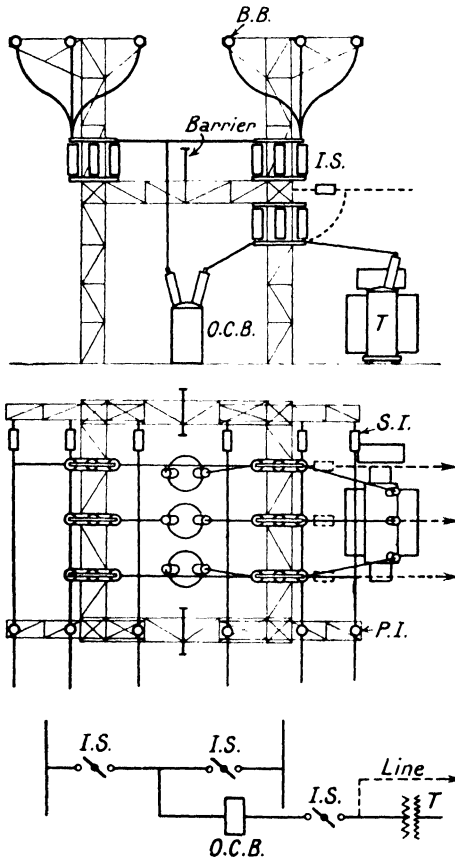

FIG. 15. DOUBLE BUS-BAR ARRANGEMENT WITH GANG-OPERATED ISOLATING SWITCHES

One circuit per bay. The alternative connections for the transformer or transmission lines are shown. Lattice structure, High type. This arrangement is used extensively on the 132 kV. British Grid.

principle, briefly, is to mount all apparatus as near to ground level as regulations and safety permit.

Such stations are known as the "Low" type and have the following additional advantages: isolating switch drives are simplified; a general inspection can be made from ground level;

the scheme of connections is easier to follow, and the complete cost is usually lower than the high type. The steel structure used in the high station is replaced by a number of isolated trestles and pedestals which often carry but a single piece of apparatus. In such cases, a workman cannot walk from a dead

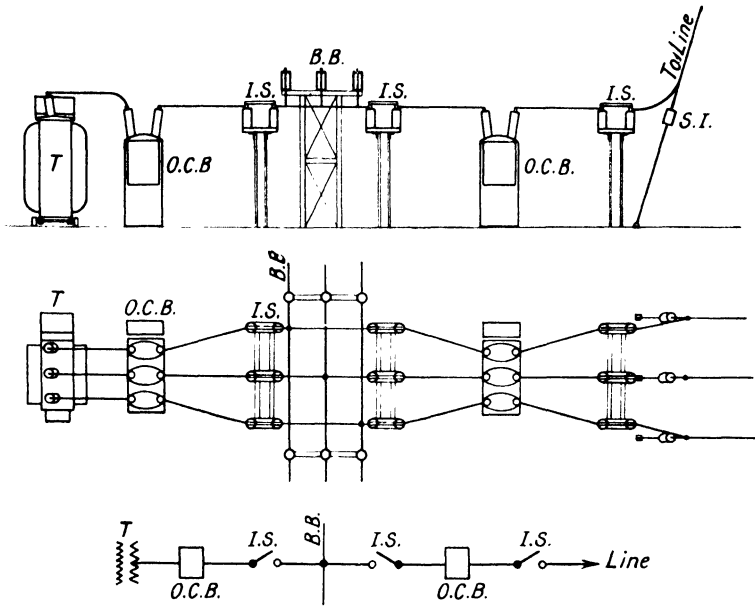

FIG. 16. SINGLE BUS-BAR ARRANGEMENT WITH GANG-OPERATED ISOLATORS

Two circuits per bay. Suitable for any voltage. Steel pedestals shown. Low type.

to a live section. Where a low lay-out is required for accessibility, and concrete cannot be used for the pedestals owing to transport or manufacturing difficulties, steel can, of course, take its place. The ground space occupied is larger and site costs will in some cases absorb the price advantage. Drawing office time is reduced due to the simple structures, which in many instances are duplicates of each other.

A comparison of the costs and apparatus necessary for both high and low stations of the three-breaker, double-bus, and mesh type stations is given in Table I, page 17. Figs. 16 to 20 show a number of key arrangements.

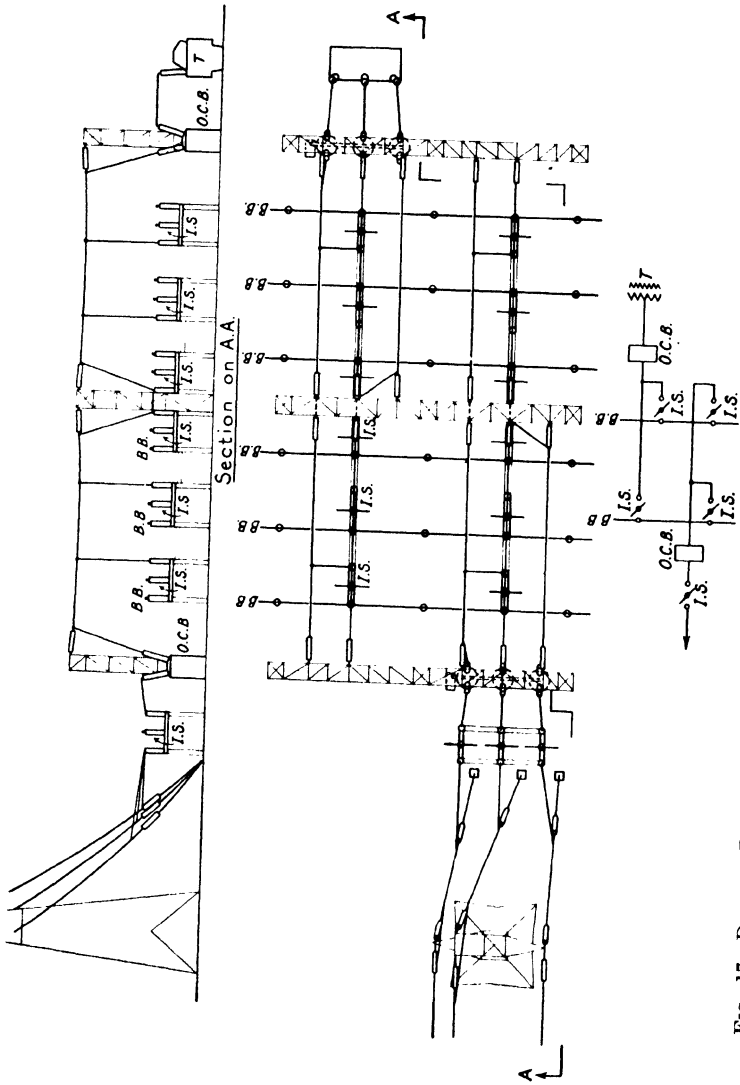

FIG. 17. DOUBLE BUS-BAR ARRANGEMENT WITH TANDEM-MOUNTED GANG-OPERATED ISOLATORS
 One circuit per bay. Suitable for any voltage. Steel towers for jumper connections and concrete pedestals
 for insulators are shown. T.C.B. stands for tandem-mounted gang-operated breakers.

NATIONAL SPECIFICATIONS DEALING WITH OUTDOOR STATIONS

Most National Specifications include some reference to outdoor switchgear. The types of regulations laid down, however,

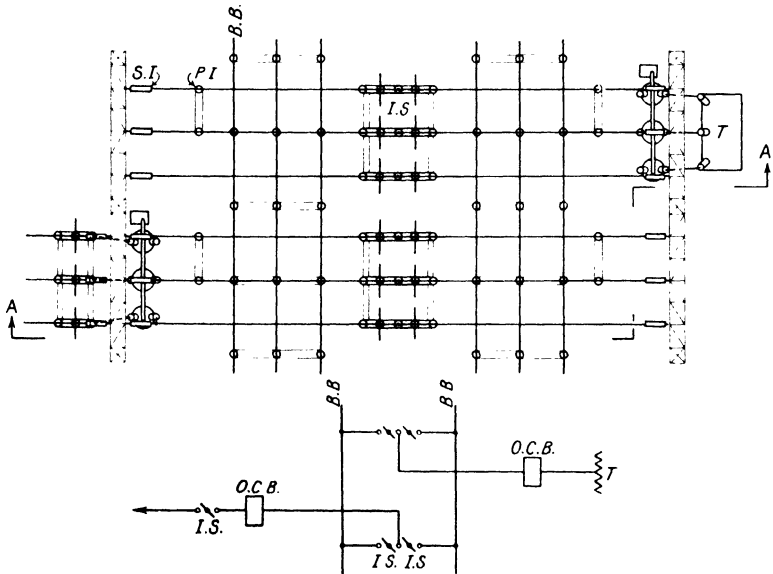
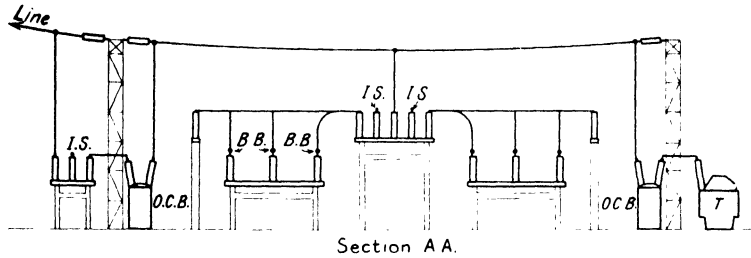

FIG. 18. AN ALTERNATIVE ARRANGEMENT TO FIG. 17 WITH PARALLEL MOUNTING FOR ISOLATORS
Note double isolator for bus-bars.

vary considerably. As examples, the British and American Specifications can be cited.

The American N.E.M.A. Switchgear Standards Publication No. 31—10, May, 1931, establishes the following in some detail—
A standard form of tender to be used by switchgear suppliers.

TABLE 1*

	3-Switch: 2 Feeders and 2 Transformers		Controlling 4 Feeders and 2 Transformers		
	High	Low	Double Bus-bar		Mesh
			Standard		
			High	Low	
Approx. cost of switchgear, with foundations, ferro-concrete, and/or steel structures . . .	£17 500	£16 000	£34 500	£30 000	£27 000
Area of site, sq. yd.	1 200	2 800	4 000	6 500	5 400
No. of oil circuit-breakers	3	3	7	7	6
No. of isolators	10	10	22	28	22
No. of post insulators	6	18	42	42	20
No. of suspension insulators . . .	—	—	24	—	—
No. of strain insulators	20	—	12	78	36
Length of rigid conductors, yd. . .	120	200	—	300	200
Length of flexible conductors, yd. .	12	—	1 300	1 200	1 000

A steelwork specification, current ratings of bare conductors, and phase spacing for isolators, horn switches and bus-bars. These dimensions are given as phase centres, not clearances: a rather uncertain method, as phase clearances will vary with the dimensions of the apparatus.

Safety standards are recommended for all types of switchgear, although these regulations are not legally compulsory, and the table of clearances from ground to live metal designated as "Isolation by Elevation" may be ignored and the table issued in the "National Electrical Safety Code" used in its stead. This latter publication is No. 3 of the Handbook series of the Bureau of Standards published by the United States Government Printing Office, Washington.

The publication is a comprehensive volume covering many sides of electrical engineering, and in addition to safety recommendations provides information tables on practical subjects such as transmission line tensions, sags, depreciation of wood poles, etc.

Rule 114 covers the guarding of live parts, and as no particular mention is made to outdoor application, it can be assumed that the clearances given apply.

* "The British Grid System," W. A. Coates. Paper read before the Belfast Association of Engineers.

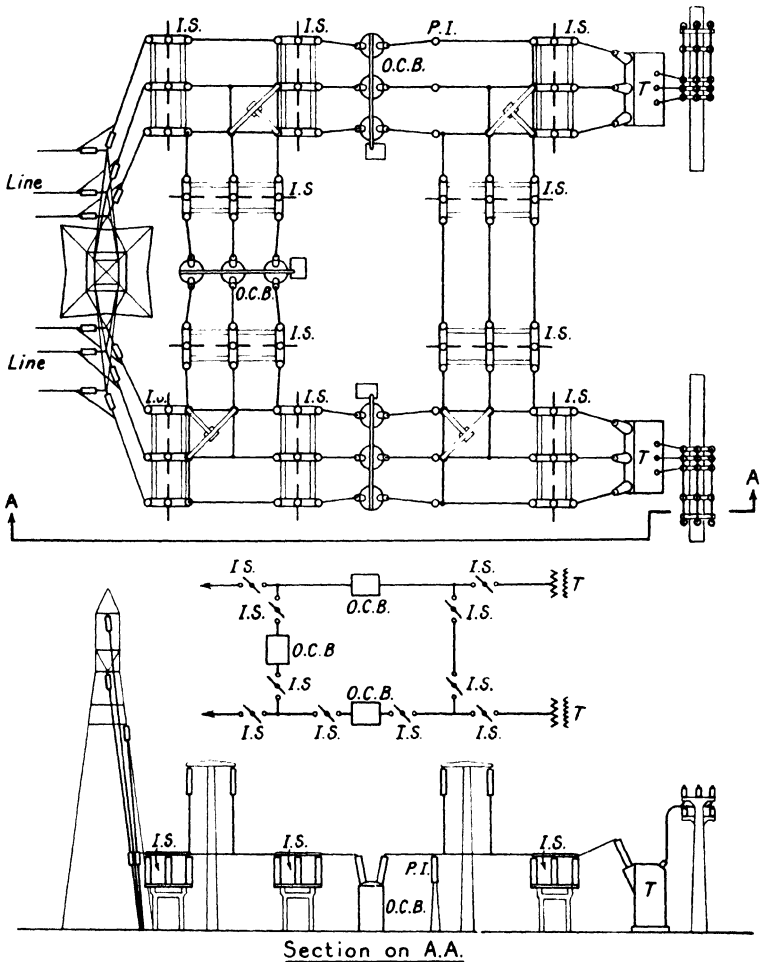
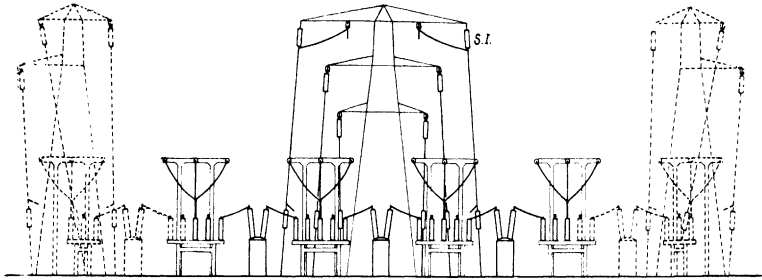

FIG. 20. A "THREE CIRCUIT-BREAKER" TYPE OF STATION (FIG. 4)
 BUT OF THE NON-EXTENSIBLE TYPE
 As used on the British Grid.

Three different sets of dimensions are specified ; the minimum vertical clearance of unguarded parts, the minimum horizontal clearance of unguarded parts, and the minimum clearance from guards to live parts. The vertical clearances are of the same order as in B.S.S. No. 162 ; for instance the American clearance



Section on A.A.

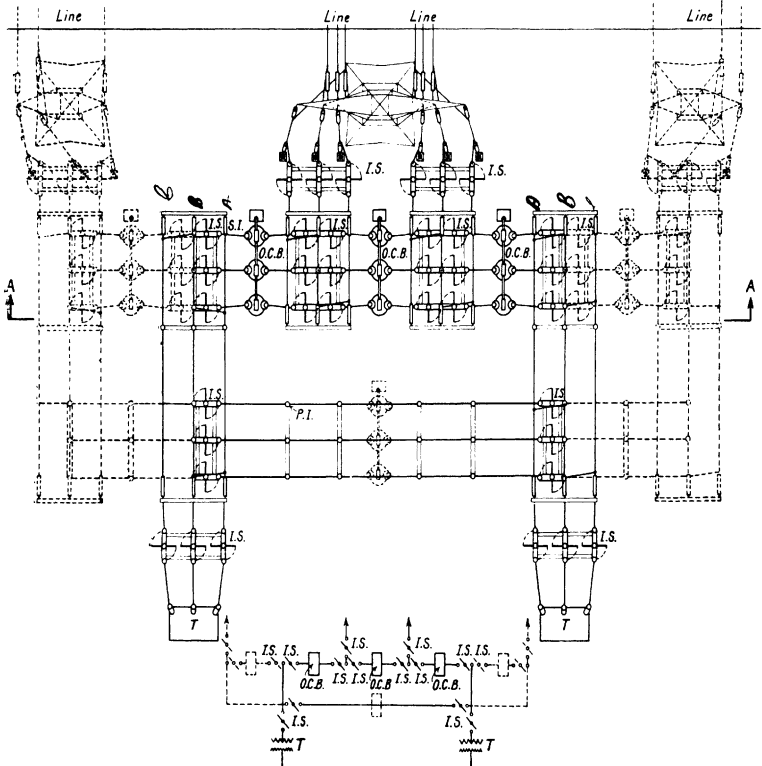

FIG. 19. THE "THREE CIRCUIT-BREAKER" TYPE OF STATION (FIG. 4), SHOWING EXTENSION TO "MESH" ARRANGEMENT (FIG. 6)

Concrete structures shown except for transmission line tower. As used on the British Grid.

for 11 kV. is 9 ft., whilst the British clearance is 8 ft. 6 in.; for 132 kV. the American Specification gives 12 ft. 2 in., and the British gives 11 ft. 3 in. The horizontal clearances, however, vary between one-half and one-third of the vertical clearances. The 11 kV. horizontal clearance is given as 3 ft. 6 in. and the 132 kV. clearance as 6 ft. 8 in. B.S.S. No. 162 makes no difference between horizontal and vertical safety clearances. The Clearance to Guards table is issued as a guide to workmen employed in installing guards for temporary work.

British Regulations as set forth in B.S.S. No. 162—1934 establish two important standards; the minimum electrical clearances (B.S.S. No. 162, Table III) that may be considered electrically safe, and definite regulations and clearances to ensure the safety of operating and maintenance engineers (B.S.S. No. 162, Table IV). These tables of clearances and some of the explanatory data connected with them are reproduced on pages 35 to 41. Outdoor bus-bar clearances from B.S.S. No. 159 are given on page 21.

B.S.S. No. 162, Appendices III and IV, explains in some detail various schemes for dealing with the safety clauses in the specification. This information has a direct bearing on station lay-out, and is therefore reprinted in full as an appendix to this chapter. The reader is recommended to read this appendix before proceeding further.

The increase in cost to comply with the safety regulations is not as formidable as would at first appear. The old method of designing a station to give electrical clearances only is still permitted. The dimensions given in Table III of B.S.S. No. 162—1934 must, however, be observed for clearances from ground to live metal, and the whole station be shut down when work, involving men leaving ground level, is required.

In cases where atmospheric conditions are such that insulator cleaning is seldom, if ever, necessary, it is considered reasonable to assume that maintenance work aloft will not exceed one overhaul per year. In many instances this time interval will be exceeded.

The inspection and adjustment of oil circuit-breaker and isolating switch operating mechanisms can be added to the list of maintenance work given in B.S.S. No. 162 as possible from ground level.

When a complete shut down is impossible, sectionalization is essential. Where sufficient ground space is available, the

OPEN BUS-BARS. OUTDOOR TYPE*

The clearance distances specified in this table apply to rigid bus-bars only. When the suspension permits of swinging, these clearance distances must be maintained for the maximum amplitude of swing.

TABLE IX

Rated Voltage between Phases or Poles	Minimum Clear- ance to Earth in Air	Minimum Clear- ance between Phases in Air
kV.	Inches	Inches
6.6	6	8
11	7	11
22	9	17
33	13	23
44	16	28
55	20	34
66	23	41
88	30	52
110	37	64
132	44	76
165	55	94
220	72	125

* Abstracted by permission from British Standard Specifications No. 159—1932 (Table IX). This publication can be obtained from the British Standards Institution, 28 Victoria Street, London, S.W.1, price 2s. 2d., post free.

22 OUTDOOR HIGH VOLTAGE SWITCHGEAR

spacing method is preferable, as large permanent screens are often difficult to instal and are usually unsightly.

It is seldom necessary to treat each circuit as a section, and most cases are met by dividing the station into two parts. Such a division is helped by spacing the oil circuit-breakers at the section clearance from the line side of their isolators, thus allowing complete access to this important piece of

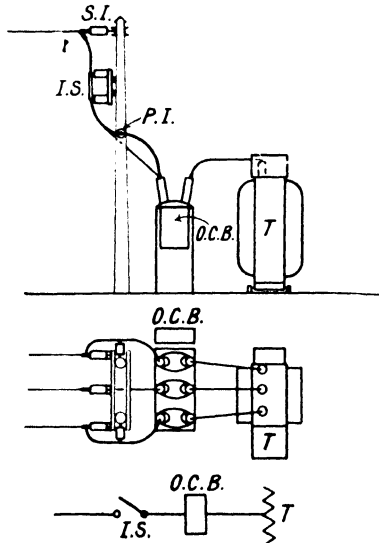

FIG. 21. SINGLE LINE TERMINATING AT A TRANSFORMER

apparatus, with the remainder of the station alive. This scheme is particularly useful for breakers having floor-mounted tanks to which access is obtained by a manhole in the top. Figs. 16 and 19 illustrate this point.

High stations must be provided with suitable ladders to obtain access to all parts, and hurdles must be placed on horizontal girders between sections to prevent workmen crossing from a dead to a live section.

The Choice of a Suitable Site for an Outdoor Station. In most cases a number of alternative sites are available for any one station; the general requirements are therefore worth recording.

Among the most difficult situations are those met with in congested areas. The actual choice of the site in this case is

usually simplified by the fact that there are few alternatives. Space is, as a rule, the main difficulty, and considerable ingenuity is sometimes required to accommodate all the apparatus. An example is shown in Fig. 23.

When several sites are available, each should be investigated thoroughly, and the various points for and against tabulated in order to arrive at an accurate comparison. The type of

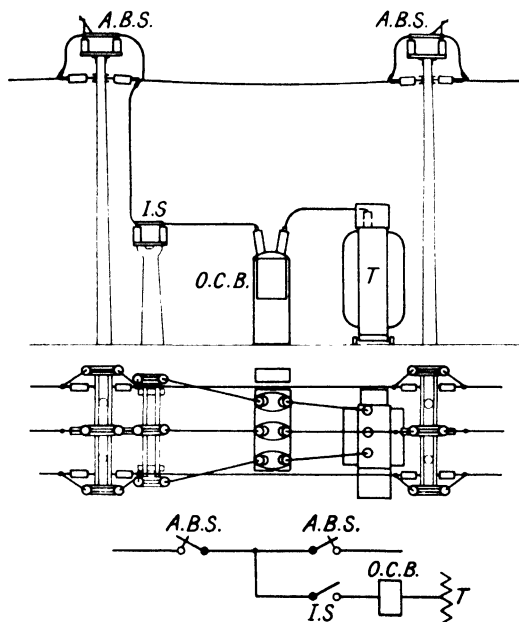

FIG. 22. SINGLE TEE OFF FROM A LINE TO A TRANSFORMER

station desired, viz. high or low, is first decided, and a rough lay-out made in order to establish the area required. This drawing should include the space necessary for future extensions. The proposed approach of the transmission lines should be plotted for each site, as this information may influence the station lay-out.

The character of the ground itself comes next in importance, in order that an approximate estimate of foundations can be made. One site may have a rock bed just below the surface, whilst another may be swampy. The latter kind would make pile driving or even a complete concrete raft necessary. The

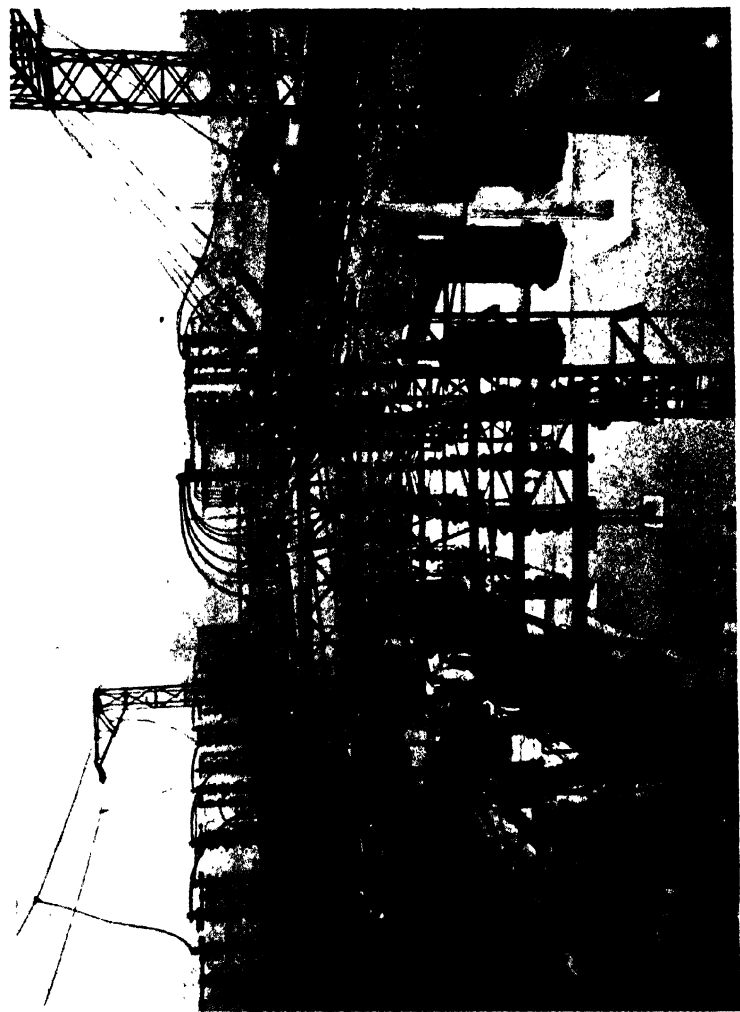

FIG. 23. 132 KV. OUTDOOR SWITCHING STATION AT GREENOCK (SCOTTISH GRID)

Diagram 9 c for Fig. 4

levelling of ground may be expensive, and when surplus earth requires to be removed from the site, the cost of transport and dumping should be included.

These civil engineering investigations must also include a survey of a suitable approach road to the station. The transformers are usually the largest and heaviest load. In one case known to the authors the approach roadway, which passed under a railway bridge, had to be excavated at this point to allow the transformer to pass.

Finally, purchasing prices and any legal obligations should be recorded.

From such data, the choice of the most suitable site will present little difficulty.

It may be that the site has necessarily to be at some considerable altitude, and whilst in this case the same attention to the points given above apply, there is, in addition, the question of the reduced spark-over value of the insulators at this altitude. Curves are given in B.S.S. No. 223—1931 for altitude corrections to spark-over values for certain temperatures. In order to enable the reader to calculate the effect of altitude on spark-over for any case, the following deduction is given—

The relative spark-over voltage at any altitude may be determined from the standard equation for relative air density

$$\delta = 0.392b/(273 + t) \quad . \quad . \quad . \quad . \quad . \quad . \quad (1)$$

In this equation, b is the barometric pressure, which varies with altitude in accordance with the equation

$$H = 153.85t \{ 1 - (b/b_0)^{1.9} \}^* \quad . \quad . \quad . \quad . \quad . \quad (2)$$

where H is height in metres, t temperature at ground level in degrees C., b_0 barometric pressure at ground level, and b barometric pressure at height H . In Fig. 24 a curve is given for variation of barometric pressure with height. The variation of temperature t with altitude is given in curve Fig. 25.

As an example, suppose it is required to know the spark-over voltage at an altitude of 1 500 m. of an insulator that at normal temperature and pressure has a spark-over value of 120 kV. From the curve in Fig. 24 it is found that the barometer reading for 1 500 m. is 632 mm., and from the curve Fig. 25 the

* *Glazebrook's Dictionary of Applied Physics*, Vol. III.

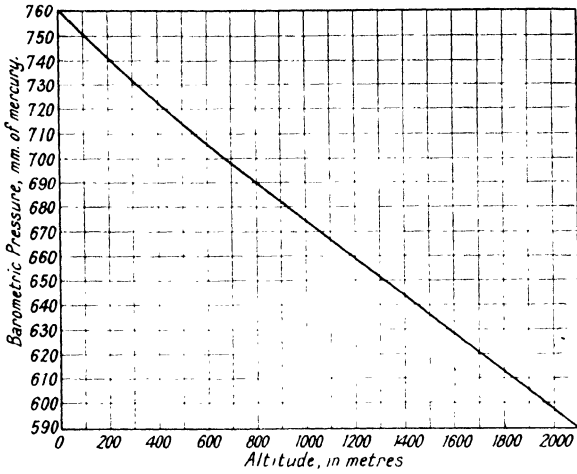

FIG. 24. VARIATION OF BAROMETRIC PRESSURE WITH ALTITUDE

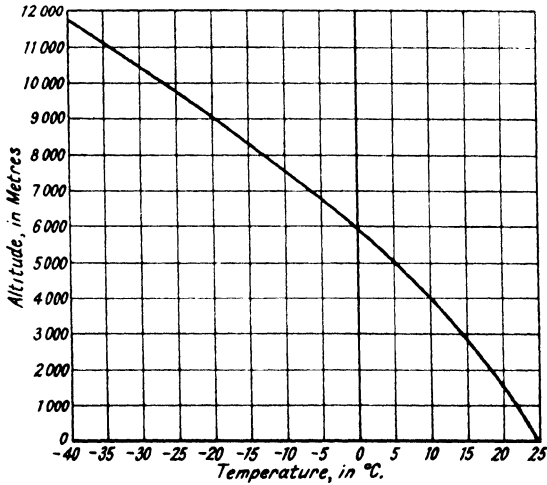

FIG. 25. SHOWING MEAN DISTRIBUTION OF TEMPERATURE WITH ALTITUDE

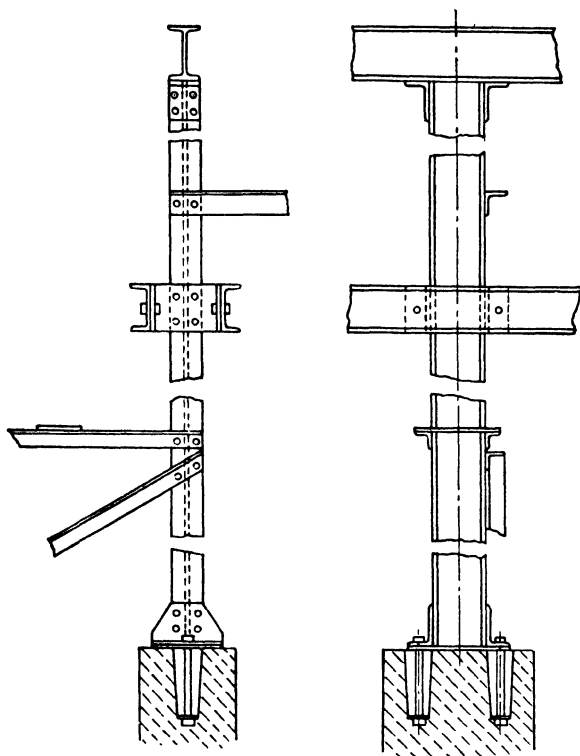

FIG. 26. TYPICAL JOINT CONSTRUCTION USED ON GIRDER
HIGH TYPE STRUCTURES

temperature at this altitude is about 20° . Substituting these values in equation 1, the correction factor is

$$\delta = \frac{0.392 \times 632}{273 + 20} = \frac{250}{293} = 0.85$$

whence spark-over voltage = $120 \times 0.85 = 102$ kV.

STEEL STRUCTURES

When the total height of a structure does not exceed 30 ft. and the longest span 18-20 ft., simple joist and channel construction is the most satisfactory and economical. Most high type stations up to 66 kV. are constructed in this manner.

Fig. 26 shows a few typical details. High stations similar to Figs. 14 and 15 may have a tower height up to 60 ft., with girder spans of 50 ft.

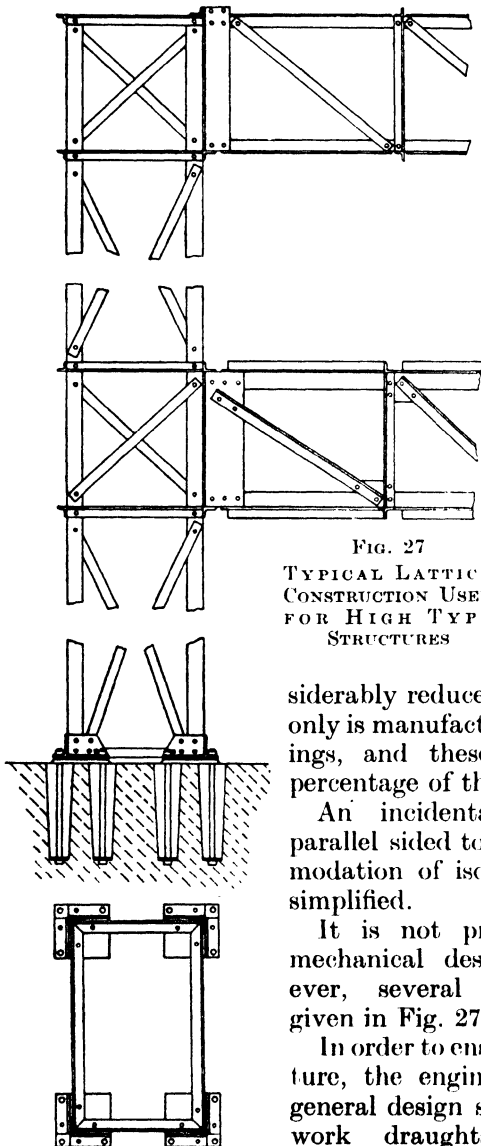

FIG. 27
TYPICAL LATTICE
CONSTRUCTION USED
FOR HIGH TYPE
STRUCTURES

In such cases a fabricated lattice arrangement is employed.

Early type up-rights or towers were constructed in a similar manner to transmission line towers with a wide base tapering upwards to the dimensions decided for the horizontal girders. This design, while technically sound, is more expensive than the modern parallel sided tower. This latter type is built up on standard units, and drawing office and template-making time is thereby

considerably reduced. Usually one station only is manufactured to one set of drawings, and these charges form a big percentage of the complete cost.

An incidental advantage of the parallel sided tower is that the accommodation of isolating switch drives is simplified.

It is not proposed to enter into mechanical design. There are, however, several constructional details given in Fig. 27.

In order to ensure a satisfactory structure, the engineer responsible for the general design should supply the steel-work draughtsman with complete

loading data. Some of the information is peculiar to outdoor switchgear, and a summary is given.

1. **Tension Loading.** In most high stations, the transmission lines, which may approach from varying directions and have different tensions, are terminated on the structure. Similar loading may also be imposed by strained bus-bars or connections within the station itself. Accurate angles and tensions are necessary as the stresses imposed will affect the construction. It is usual to specify that permanent distortion of the structure shall not occur should any one of a three-phase set of strained leads break.

2. **Dead Weight Loading.** The weight of the apparatus to be mounted is the principal item under this heading. Outline drawings of each piece, giving particulars of weight distribution in cases of unbalanced loads, should be supplied. Where accurate snow and ice loading is known, it should be given as x lb. per sq. ft. on all horizontal surfaces. A safe value for England may be taken as 5 lb. per sq. ft.

3. **Windage.** Apart from the maximum velocity or wind pressure, it is desirable to give the particulars of any shielding that may be afforded, such as a power station building or hill. It is preferable to specify windage in pounds per square foot, and in the absence of definite information, the following loadings can be taken to cover all normal cases—

ON LATTICE COLUMNS AND GIRDERS: 25 lb. per sq. ft. on $1\frac{1}{2}$ times the projected area.

ON OTHER FLAT SURFACES: 25 lb. per sq. ft. on the projected area.

ON CYLINDRICAL AND ROUND SURFACES: 18 lb. per sq. ft. on the projected area.

Opinions differ on the relationship between velocity and pressure. Further, the pressure varies with the height above ground and barometric pressure. It should also be noted that *indicated* and *actual* pressures vary. Therefore, in all calculations on stresses from wind pressure, care must be taken that actual wind velocity is known apart from indicated wind velocity. There are various methods by which wind velocity is measured, but none gives actual results. Experiments have been carried out at the National Physical Laboratory which show that by comparing the *cup anemometer* method side by side with the *pressure tube anemometer*, the ratio of the speed of the wind to the speed of the cups, usually

known as the *factor* of the anemometer, is not constant. This ratio is found to vary with the actual wind velocity, being greater at low than at high velocity. The variation is not due to friction in the instrument, but rather to inconstancy of the inertia of the cups at different wind speeds. The value of the factor for the cup anemometer is now taken as 2.2, and is found to be correct for an actual wind velocity of about 22 miles per hour. For stronger winds the factor exaggerates the true speed, while for lighter winds it understates it.

It is perhaps better practice to design for indicated velocities, since the anemometers used give an indicated velocity, which is an average over several minutes. Therefore sudden gusts during that period may not be far different in actual value from the indicated velocity given for the average value. By this practice the worst condition is provided for.

As an example, the figures given above may be taken as being approximately equivalent to an indicated wind velocity of 102 m.p.h., and an actual velocity of 77 m.p.h. Wind pressures are dealt with at some length by Still.

Isolating Switch Operation. The operation of ganged isolating switches often imposes considerable stress on the structure, and the nature and magnitude of these stresses should be understood and allowed for by the structure designer. Lack of attention to this point causes increased friction in the operating mechanisms, and many cases of difficult operation have been due to a too flexible structure. Co-operation with the steel draughtsman also enables guides, mountings, etc., to be incorporated in the main fabrication.

Erection and Maintenance Loadings. The weight of workmen on the structure during erection of the apparatus may impose considerable stress, particularly on long horizontal girders. If ignored in design, permanent distortion may result. In other instances the temporary sag caused may render impossible the setting of switch operating gear. A minimum of two 12-stone men working together on any part of the structure should be allowed for. In many instances lifting tackle is necessary to hoist the apparatus into position, and points of attachment should therefore be fixed and a maximum lift given.

Electrical Clearances. The run of bus-bars and connections in many cases makes it impossible to fit bracings in the most desirable positions from the mechanical standpoint.

Connections should, therefore, be clearly shown on the general arrangement drawing, together with the electrical clearances desired.

A careful check of the steelwork drawings should be made by the electrical draughtsman to ensure that electrical clearances are maintained.

Stress Diagram. In all lattice type structures where uneven loadings are imposed, a mechanical stress diagram should be prepared.

In the absence of an official steel structure specification, compliance with the following requirements will ensure a sound construction, provided good workmanship is obtained.

Material. All steel used, including that for bolts and nuts, is to comply with B.S.S. No. 15 for grade "A" steel, and all rolled sections with B.S.S. No. 6. The minimum thickness for main members to be $\frac{1}{4}$ in. for galvanized structures, and $\frac{5}{16}$ in. for painted structures. For other members these minima may be reduced to $\frac{3}{16}$ in. when galvanized, and $\frac{1}{4}$ in. when painted.

Design. When single bolted connections are used, the minimum diameter of bolt is to be $\frac{5}{8}$ in. In cases where one $\frac{5}{8}$ in. bolt would take the load but where two bolts are required to fix an end, $\frac{1}{2}$ in. diameter bolts may be used.

Each bolt shall be provided with a lock washer of approved type. All bolts shall have a shank length such that shear forces are taken on the unscrewed portion.

Punched holes are not permitted for members over $\frac{3}{8}$ in. in thickness.

Riveted or welded assemblies shall not be used unless special agreement is obtained. (Apart from the additional cost of shipment for assembled parts, experience has shown that deformation during transit is difficult to avoid and costly to rectify.)

Factor of Safety against Overturning. The complete structure shall have a factor of safety not less than $2\frac{1}{2}$ against uprooting or overturning.

Foundations. The area of column base plates to be such that the loading on the concrete foundations does not exceed 12 tons per sq. ft. The foundations should finish 6 in. above ground level. The structure shall be secured to the foundations by anchor bolts and not by grouting in.

Stresses. The following unit stresses are not to be exceeded—

Tension on net section	17 900 lb. per sq. in. (8 tons)	per sq. in.
Single shear on bolts	12 000 ..	(5·35 tons) ..
Double shear on bolts	21 000 ..	(9·4 tons) ..
Bearing pressure on bolts	24 000 ..	(10·7 tons) ..
Compression on gross section for		
members with fixed ends	17 900 [1 - 0·0033(L/R)]	lb. per sq. in.
Ditto for pin jointing	17 900 [1 - 0·005(L/R)]	..

where L is the greatest length in inches of the unbraced portion of the member and R the least radius of gyration in inches; provided that the working compression stress on the cross-section in no case exceeds 15 200 lb. (6·7 tons) per sq. in. These figures give a minimum factor of safety of four based on the ultimate stress of the material.

Slenderness Ratio. In no case is a compression member to have a greater unsupported length in inches than 120 times its least radius of gyration in inches, or 45 times its least width in inches.

Galvanizing. Hot dip galvanizing, complying with B.S.S. No. 443, shall be applied after all machining, drilling, etc., has been completed, with the exception of nuts which shall be screwed after galvanizing and the threads greased.

Marking. Each member shall have its part number stamped upon it to such a depth as to be clearly legible after galvanizing.

Galvanizing versus Paint. The correct finish for outdoor steelwork is not definitely established, and some authorities prefer a particular paint to hot dip galvanizing. Both finishes can be effective, provided they are applied in a correct manner, and their quality is sound.

Galvanizing is perhaps deservedly the more popular. It can be completed at the factory on each separate piece. The steel must be suitably cleaned, otherwise the zinc will not adhere. The finish is not easily damaged in transit.

It is equally important that steel should be clean and free from rust before painting. Unfortunately, paint will adhere quite well for a few weeks on rust and dirt. The quality of the spelter used in galvanizing varies but little, whereas the types and qualities of paint are legion. Final painting must always be done on site, owing to transport damage, and considerable harm can be done to the paintwork by workmen climbing the structure. The best finish is to galvanize, erect, then allow twelve months' weathering, and paint with a paint of proved quality.

REINFORCED CONCRETE STRUCTURES

The principal advantage of concrete is its resistance to all weather conditions. Provided it has been manufactured correctly, it requires no maintenance.

High Structures. The application of concrete structures to the high type of lay-out is limited by the large sections necessary for high towers and long beams. It is difficult to give limiting

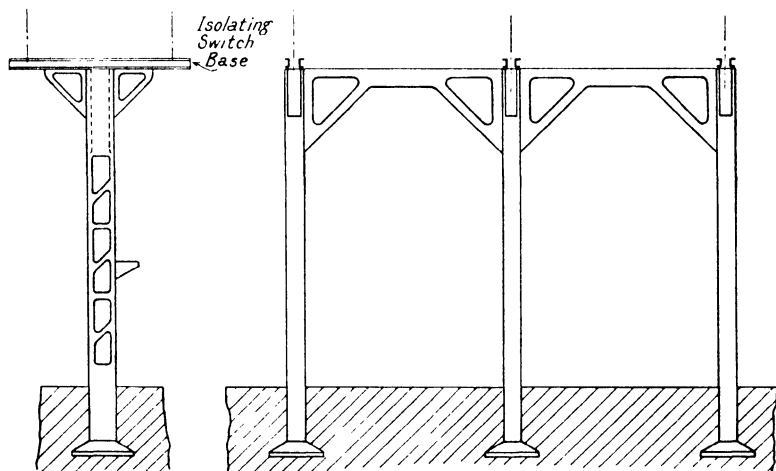

FIG. 28. CONCRETE PEDESTAL FOR ISOLATING SWITCH MOUNTING

Ferro-Concrete and Electrical Construction, Ltd.

dimensions as they are governed by manufacturing methods, and the design of the steel reinforcements.

A normal station arrangement at 66 kV. may be taken as the economical limit. The cost will in most cases be far in excess of a similar steel structure, and the only advantage is immunity from rusting. There are several methods of construction. One is that of casting the complete structure in position, by erecting shuttering of the desired shape in which have been fixed the necessary steel wire reinforcements. This design produces a heavy appearance, as the sections are large. A more slender construction is obtained by making the structure of steel joists, etc., similar to a normal steel one, and encasing it in concrete on completion. The lattice type shown in Fig. 28 would appear to have definite advantages, due to

the weight reduction it allows obtained thereby and its pre-cast manufacture. A more elegant appearance is obtained, and rigidity is provided through specially designed reinforcements. The authors have no record of such a station having been made.

Stations constructed of hollow concrete poles cast by a centrifugal method have been used in Germany.



FIG. 29. PHOTOGRAPH TAKEN DURING THE CONSTRUCTION OF THE STONEMWORK FOR A 132 kV. BRITISH GRID SUB-STATION
(Central Electricity Board)

Low Structures. Trestles required for the low type of station afford the best scope for concrete, and the costs of such structures are usually cheaper in concrete than in galvanized steel.

Invariably the pedestals, etc., are cast on site. The method of casting in position by the erection of shuttering, in a similar manner to that described for high stations, may be used. This procedure proves expensive where a number of units are identical, due to the joinery work involved in shutter construction. In such cases pre-cast methods have the advantage

that the moulds are constructed to lie flat on the ground, the unit being extracted therefrom after setting. Thus many pieces can be cast in the same mould, and the cost of erection is more than outbalanced by the saving in moulds and the simpler casting method. The finished appearance is similar in either of the above methods. (Fig. 29.)

A Specification for reinforced concrete is not given here, as this information can be found in any Civil Engineering handbook.

Indoor Mounting. The number of installations which are mounted indoors has decreased considerably during recent years.

There are, however, certain cases where such protection is necessary, among which may be included stations located in districts where any of the following conditions exist—

(a) Heavy falls of snow.

(b) Atmospheric pollution, such that insulator maintenance is impossible.

(c) Congested areas where sufficient space is not available, even for a high station, and where bare copper connections are rendered dangerous.

In all such cases, metalclad gear is superseding the older type of open lay-out arrangement, as marked space economy is obtained thereby. This class of gear is dealt with in Chapter XVI.

APPENDIX

The following appendices from British Standards Specification No. 162—1934* are reproduced by permission.

CLEARANCE DISTANCES FOR OUTDOOR SWITCHGEAR, OPEN TYPE

47. Clearance distances on switchgear incorporated in the arrangement shall be not less than the figures given in Tables III and IV.

The clearance distances specified in Table III apply to rigid conductors only. When the suspension permits of swinging, these clearance distances shall be maintained for the maximum amplitude of swing.

* Copies of this publication can be obtained from the British Standards Institution, 28 Victoria Street, London, S.W.1, price 2s. 2d., post free.

TABLE III
CLEARANCES FOR RIGID CONDUCTORS OTHER THAN BUS-BARS *

1	2		3		4	
Rated Voltage	Min. Clearance Distance to Earth in Air		Min. Clearance between Poles in Air		Min. Clearances between Terminals on One Pole in Air	
kV.	ft.	in.	mm.	ft.	in.	mm.
6.6	0	5	127	0	7	178
11	0	6	152	0	10	254
22	0	8	203	1	2	356
33	0	12	305	1	6	457
44	1	2	356	1	11	584
55	1	5	432	2	4	711
66	1	9	533	2	9	838
88	2	3	686	3	7	1 092
110	2	9	838	4	5	1 346
132	3	3	991	5	3	1 600
165	4	0	1 219	6	6	1 981
220	5	4	1 627	9	0	2 743

* This Table is reproduced from B.S.S. No. 116--1929. Table VI. For clearances for bus-bars, see B.S.S. No. 159.

TABLE IV
SECTION CLEARANCES FOR SAFETY PURPOSES, TO ENABLE INSPECTION, CLEANING, REPAIRS, PAINTING AND GENERAL MAINTENANCE WORK TO BE CARRIED OUT

Rated Voltage	Minimum Clearances to Ground Level, Platform Level (or Other Position where Men may Normally Stand with the Switchgear Alive) from Nearest Live Conductor in Air		
kV.	ft.	in.	mm.
6.6	8	5	2 565
11	8	6	2 590
22	8	8	2 641
33	9	0	2 743
44	9	2	2 794
55	9	5	2 870
66	9	9	2 972
88	10	3	3 124
110	10	9	3 276
132	11	3	3 429
165	12	0	3 657
220	13	4	4 064

NOTE. For the application of the above Table, see Appendix III.

APPENDIX III*

NOTES ON ISOLATION OF SECTIONS AND CIRCUITS

Maintenance work in an outdoor open-type sub-station must be carried out with safety to the men engaged, and therefore isolating switches are provided in order to render a sufficient portion of the equipment dead. The sub-station is usually divided into sections, but a section is normally itself subdivided into circuits by isolators, so that individual circuits or pieces of apparatus may be dead, although not necessarily, for the purposes of work thereon.

It is important to recognize the use to which these two kinds of isolation should be applied, since the dimensions in Table IV are laid down for the clearances between the nearest conductors of neighbouring sections, while there need be only the clearances of Table III between the parts of adjacent circuits not worked on above ground level whilst either circuit remains alive.

It is specified that all conductors which can be made alive must be situated a minimum distance above the ground, rendering it safe for a man to move about amongst the equipment, even when it is "alive," provided he does not leave ground level and does not use long tools or materials. Any work, therefore, that can be done from the ground is carried out without risk if the piece of apparatus upon which he is engaged be isolated; and when the section is divided into circuits, only that circuit involved need be made dead. Such functions include—

(a) Painting the oil circuit-breaker and transformer tanks supporting steel-work and other parts as far as the man can reach from the ground without artificial means.

(b) Testing and adjustment of transformer tap-changing, trip coils and operating mechanisms.

(c) Drawing-off and replenishing the oil.

(d) Inspection of contacts (where the oil switch tank can be lowered to ground level by the operator).

(e) Testing of multi-core cables and protective gear.

(f) Isolation of an overhead line or underground cable for testing or maintenance.

The above list is important, as it includes the most frequent maintenance operations required in an outdoor sub-station.

Other maintenance work which involves ascending above ground level brings the workman within reduced clearances of conductors which are ordinarily alive, and he can only be safeguarded by ensuring that a sufficient radial clearance separates him from live metal, supplemented where and when necessary by divisions, screens, or other means. For work carried out above ground level, the whole section in which he is working must be made dead.

There is thus no difficulty in distinguishing between the two sets of conditions, and it is simply necessary to lay down that no man must leave the ground or use long tools or materials in an outdoor sub-station without first assuring himself that the whole section has been made dead, and that no work must be done from the ground level unless he is certain that the part on which he is to work has been made dead.

* This is the extract to which reference is made on p. 20.

APPENDIX IV

SECTION DELIMITATION

The provision of section clearance and the question of supplementing them where necessary arises from the terms of Regulation 18 (*d*) of the Electricity Regulations made under the Factory and Workshop Act. High Court decisions in electrical and other factory cases have laid down the principle that it is insufficient merely to warn an employee of a danger, and that steps must be taken to protect him against the consequences of error. Whilst the methods necessary to achieve this object will depend on the conditions, the following may be taken as a guide—

(1) *Non-sectionalized Switchgear.* Where the design is such that no provision is made for division of the switchgear into separate sections as defined in this Specification, the whole of the switchgear must be made dead before work which involves leaving ground level is undertaken.

(2) *Group-sectionalized Switchgear.* Where the design is such that two or more groups of unspaced circuits can be divided into sections as defined in this Specification, the area of each may be delimited by permanent screenwork, permanent fencing, or by temporary enclosure, as by ropes or chains (see examples in Figs. 1 and 2).

The division may be temporary, in the form of ropes or chains stretched from side to side of the station, green or red flags or warning notices being placed in one section or the other to prevent mistakes in identification. Coloured lamps may be used at night, and the provision of floor sockets for temporary screen standards is recommended.

Note. Where permanent screenwork resulting in complete physical division between sections is adopted, the clearance between such sections may be in accordance with Table III.

As compared with permanent divisions, temporary methods of delimitation entail increased responsibility and care in supervision to ensure their use and effectiveness.

(3) *Circuit-sectionalized Switchgear.* Where the design is such that each circuit constitutes a section as defined in this Specification, the area of each may be delimited as follows—

(i) At ground level by indicative fencing of a permanent or removable character. (See example in Fig. 3.)

Note. Fatalities have occurred in consequence of workmen mistaking the circuit-breaker or transformer on which work is in hand.

(ii) Above ground level by divisions or screens of a permanent nature to prevent passage *via* the structure from one section to another. (See example in Fig. 4.)

(iii) Above ground level by the elimination of structural steelwork or other means of access between sections. (See example in Fig. 5.)

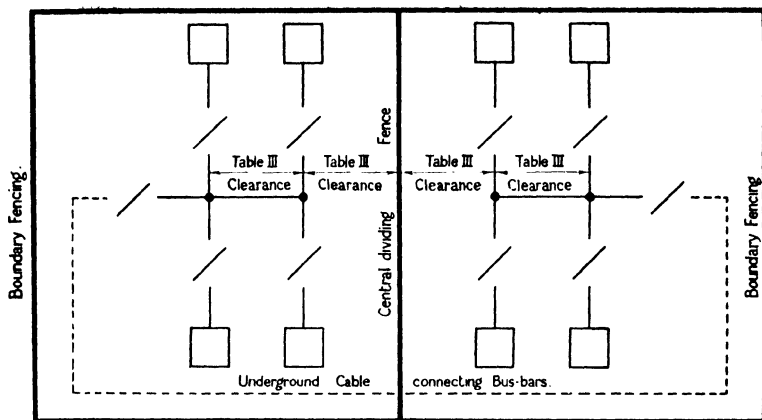

FIG. 1. CENTRAL DIVIDING SCREEN CARRIED WELL ABOVE BUS-BAR LEVEL.

Entry to each section controlled by locked doors.

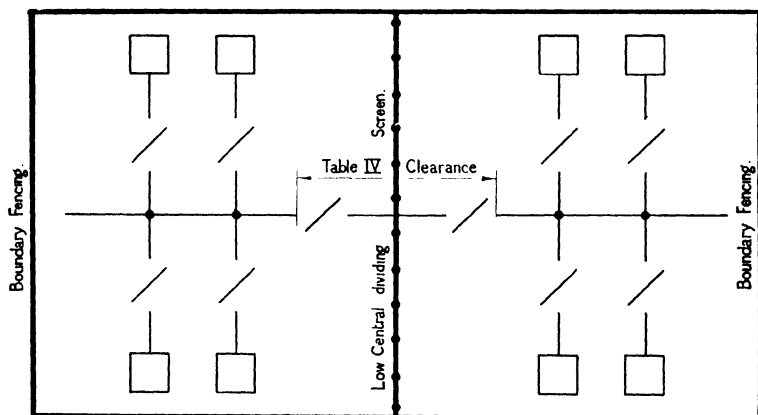

FIG. 2. LOW CENTRAL DIVIDING SCREEN ERECTED UNDER ISOLATED BUS-BAR SECTION REQUIRING TABLE IV CLEARANCES

No means of access between sections *via* structure over screen. Entry to each section controlled by locked doors.

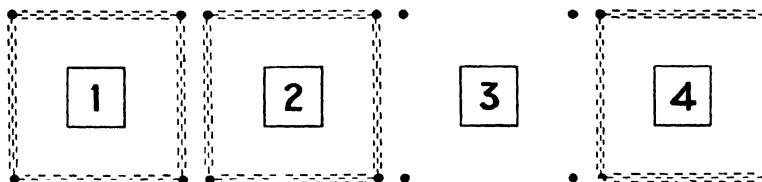

FIG. 3. LOW CHAINS PERMANENTLY HUNG ROUND CIRCUIT-BREAKERS, THE CONDUCTORS BEING SPACED IN ACCORDANCE WITH TABLE IV

Chains shown removed from circuit-breaker No. 3 to indicate that it is made dead for purposes of work thereon.

GENERAL NOTES.

(1) The question of section delimitation must be considered in conjunction with means of access to points above ground level where such work may be necessary. Design should envisage method and path or direction of access and eliminate necessity of climbing the structure. Where fixed ladders are

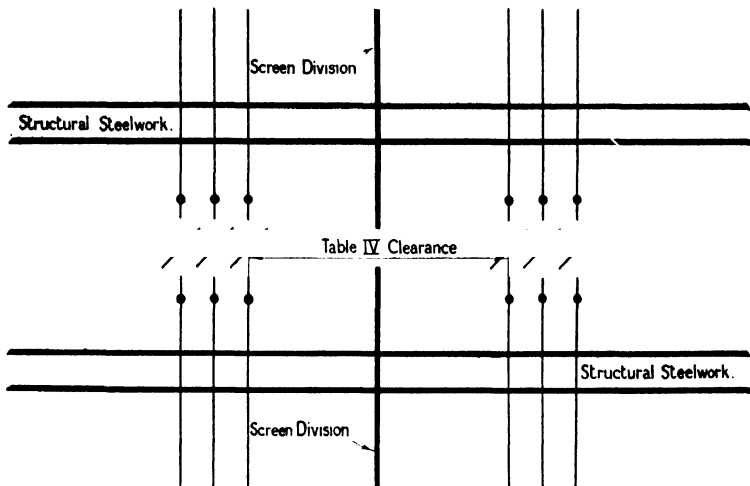

FIG. 4. SCREEN DIVISION, BARRIER FENCE OR RADIAL SPIKES
FIXED ON STRUCTURAL STEELWORK TO PREVENT PASSAGE ALONG THE
STEELWORK FROM ONE SECTION TO ANOTHER

provided, some form of locking-off, such as a hinged flap at the ladder bottom, will serve both as an indicative device and also to prevent unauthorized climbing.

(2) This appendix is intended to provide for normal maintenance work only. Should special work such as extensions, large scale renewals or work involving handling of lengths of material be necessary, special and appropriate precautions in addition are called for.

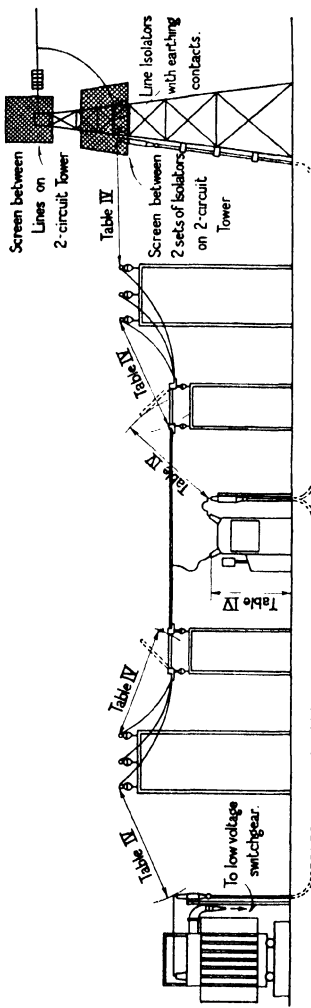

FIG. 5. NO STRUCTURAL STEELWORK OR OTHER MEANS OF ACCESS ABOVE GROUND LEVEL BETWEEN SECTIONS SPACED IN ACCORDANCE WITH TABLE IV.

BIBLIOGRAPHY

B.S.S. No. 6.

B.S.S. No. 15.

B.S.S. No. 159.

B.S.S. No. 162.

B.S.S. No. 223.

B.S.S. No. 413.

Bureau of Standards Handbook No. 3. U.S.A.

Glazebrook's Dictionary of Applied Physics. Vol. 3.

N.E.M.A. Switchgear Standards U.S.A.

Still. *Electric Power Transmission.*

CHAPTER III

ELECTRICAL PORCELAIN AND ITS MANUFACTURE

WITHOUT porcelain, high voltage transmission would have been extremely difficult, if not impossible. Its high dielectric strength, non-hygroscopic nature, and low cost make it unique among commercial materials. Substitute materials have been tried from time to time, but in the high voltage field porcelain maintains its position.

Porcelain is a material which differs in almost every respect from any other material used by the engineer, and is somewhat outside his purview. This difference is not always appreciated, and difficulties arise due either to designers expecting similar manufacturing qualities to those they would in metal, or to their having incorrect ideas as to the mechanical strength of the material. The following chapter dealing briefly with the manufacture of porcelain has been included to enable a general conception to be obtained of its possibilities, qualities and limitations.

PORCELAIN MANUFACTURE

General. Contrary to general belief, porcelain is not made from a clay found in abundance in North Staffordshire. The reason for this misunderstanding is due to the fact that most of the works making all varieties of porcelain articles are to be found in the district known as The Potteries. One of the reasons for this gathering is that North Staffordshire is an extensive coalfield, and produces fuel that is particularly applicable for the firing of pottery.

There are also extensive fireclay deposits, and this material is a necessity in the manufacture of bricks for kilns and saggars; the latter act as containers for the ware whilst being fired. The quantity of fireclay used in the Potteries runs into thousands of tons per year.

Raw Material. The clay used for making electrical porcelains is a mixture of certain plastic and non-plastic materials in very carefully graded quantities. Each manufacturer has his own mixtures, which are known as *bodies*. One maker may

have several bodies, each suitable for a particular class of work. The actual quantities of the various ingredients are as a rule kept secret. The plastic ingredients consist principally of two clays known as *ball clay* and *china clay*. England is particularly fortunate in having remarkably good supplies of both of these clays. The main sources of supply are Dorset, Devon, and Cornwall, and clays from these areas have a world-wide demand.

Both these clays are the result of decomposition of Felspathic Rock.

China clay is formed at the source of the decomposition, and a process of artificial washing removes impurities, including alkalis and the remaining decomposed materials.

Ball clay is the portion of the material naturally transported by the agency of water and re-deposited in lake beds, sometimes many miles away from its original source, having accumulated on its way alkalis and organic matter. Only the fine grained plastic clay reaches the lake beds, the coarse material having settled out during transportation.

This fineness of grain in ball clay is mainly responsible for its plasticity and its reluctance to give up its water content during drying. Both clays are used in their natural state, except for the removal of foreign matter, although variations occur in deposits taken from different sources. The biggest variation is found in the ball clays, and the alkaline contents account for some of these differences. Analysis helps to some extent in detecting these variations, but there are also physical differences in the "working" properties. As an example, a given ball clay may be strong in the wet state but weak when dry. Another may have exactly opposite characteristics. A wide variation in firing temperatures may be necessary to bring different clays to their maturing point, and to keep within a reasonable range of firing temperatures adjustments have to be made in the composition of the other materials, to compensate for the lack, or the reverse, of alkalis in the ball clay. The source from which various makers obtain their ball clay can account for some of the difference in the firing temperatures used. As the final result of a change in clay may not show until the finished insulators are taken from the kiln, careful check on material is necessary, and the ceramic chemist and his laboratory form an extremely important link in the manufacturing chain.

The non-plastic materials come under two main headings—fluxes and relatively inert material.

The flux is the vitrifying and strengthening agent used during the firing process, and under this heading there is considerable choice of substances, among which are the following: Felspars, Steatite, Calcium Phosphate, Insoluble Barium Salts, etc.

Felspar is one of the most popular fluxes, but is unfortunately almost non-existent in this country. The bulk supplies used in Great Britain come from mines in Norway and Sweden. Its fluxing properties are determined by the alkaline contents, the bulk of which is in the form of potash and soda.

The inert materials are usually a variety of Silicon Dioxide, such as quartz or flint: ground porcelain is also used. Flint is obtainable in this country in pebble form. One of the functions of these materials is to counteract distortion and possible collapse of the articles during firing, and to prevent excessive shrinkage during the drying process in the clay stage.

The characteristics of the final product can be varied by adjusting the quantities of the ingredients. Additional clay tends to improve the resistance of the porcelain to temperature changes, whilst an increase in flint adds mechanical strength. Additional felspar has the effect of increasing the dielectric strength.

The non-plastic materials also keep the body open, before firing, thereby assisting in the drying stage. Without their assistance, difficulty would be experienced in extracting the water from the centre of the article, as the ball clay, owing to the fineness of its particles, tends to fill up the pores of the mass.

Preparing the Body. The clays are prepared separately from the non-plastic materials. Their treatment is carried out in a mixing machine known as a *blunging mill*. This consists of a large circular tank, in the centre of which is a rotating shaft. Attached to this shaft are arms arranged to rotate in opposite directions. Water is added to the clay, and the rapidly revolving arms beat the contents to a uniform consistency. Free iron which is one of the impurities found in clay is then extracted by running the liquid over strong electro-magnets.

The non-plastic materials are first put through crushers or rollers, and are finally ground in special mills until the correct degree of fineness is obtained. Water is added to facilitate this process and the quantity is critical. Too little water is apt to

clog the grinding by the sticky mass produced, while too much makes the liquid so thin that little grinding action takes place.

The final mix is made in a blunging mill with all the material in a fluid state. After the specified mixing time has elapsed, the body (at this stage known as *slip*) has a consistency of thick cream, and it is necessary to extract the excess water in order to bring the mix to a plastic workable mass. The slip is therefore drawn off through sieves into filter presses. The filter press consists of a series of narrow fabric bags, usually rectangular or round in shape, and held between wood or metal trays. Each bag is filled with the slip. When all bags are full, a pressure of about 100 lb. per sq. in. is applied at the ends of the press and the excess water is forced through the fabric, leaving a pliable working body in the bag.

The next process is to eliminate air pockets and laminations. The method of accomplishing this differs with various makers.

One method which originated on the continent of Europe is to roll the clay in a machine similar to a mortar mill, but with a flat bed instead of a pan. Side rollers keep the clay from escaping over the edge and help in the kneading. Another popular method is to use a machine similar to a large mincing machine, known as a *pug*. The main carcass is barrel shape, in which are revolving knives. The knives serve the dual purpose of cutting up the clay and then pressing it through a die, which extrudes it to a shape convenient for use. This results in a homogeneous mass with respect to water contents, and an even distribution of stresses. A maturing or ageing period of several weeks is necessary after this process, and the clay is stored in cool, damp cellars for this purpose.

Forming. There are three different methods by which an insulator can be formed. They are known as—

1. Throwing and turning,
2. Jollyng, including pressing, and
3. Casting.

Each method produces the same quality of porcelain, but has its own particular application in manufacture. Before describing these methods the problem of shrinkage, which applies to all three cases, should be considered. Apart from the free and chemically combined water which is contained in most of the materials, additional water has been added to the body to bring it to the required consistency for working. A

body in a proper working condition contains approximately 22 per cent free water in addition to a further 14 per cent that is chemically combined in the clay materials. The free water is eliminated by drying after shaping. The chemically combined water cannot be removed in this way, and is driven out during firing at temperatures about 600° C. The loss of water naturally causes shrinkage and considerable movement takes place, both during drying and firing. These contractions have to be allowed for when forming an insulator in the clay stage. In certain cases a total shrinkage of 14 per cent is quite possible, two-thirds of this being during firing. This means that an outdoor end of a bushing, say 3 ft. 6 in. finished length, would be made 4 ft. long in clay. This unavoidable contraction tends to aggravate stresses set up during the forming, drying, or firing operations, which in bad cases may develop into cracks. Such cracks may not be discovered until the insulator is subjected to its routine electrical tests.

The undesirable loss from this trouble is minimized by—

1. Correct design of the insulators from the potting standpoint.
2. Careful check to ensure that the properties of the materials used in the body are constant.
3. Utilizing the correct manufacturing method for each particular type and size of insulator.
4. Due regard to drying conditions and, in the case of large articles, sufficient time allowed to permit moisture to be driven out slowly.

Throwing and Turning. This method, which has the advantage that no special tools are required, is carried out in two stages, first the throwing and then the turning. For throwing, the clay is delivered to the potter from the ageing process store. Throwing is the manipulation of the body on the potter's wheel, the latter consisting of a horizontal revolving disk. It is the potter's duty first to work the clay further to eliminate entrapped air and laminations, and finally to form the mass to the correct length and diameter for the turning process. Considerable skill is required, as incorrect working can do more harm than good, causing defects that will not develop until after the firing stage. The blank produced by the potter is too soft for turning, and a period of drying is necessary to bring the body to the required consistency.

Due to contraction the time of this partial drying is critical,

and there is only a limited range over which turning can be carried out, otherwise a batch of insulators all turned to the same size will vary on completion due to the various stages of drying they were in when turned. Some manufacturers use an extruding machine similar to a pug, which eliminates the throwing process in cases where a large quantity of blanks are required.

The turning operation is carried out in a lathe having a rest similar to that used by woodworkers. The hand tools are in profile form in accordance with the required shape of the insulator. Whenever possible a mandrel is used to support the body during this operation.

Jollyng is a method evolved from throwing. The body in this case is placed in a plaster of Paris mould shaped to one surface of the insulator. It is pressed firmly into the mould until the latter is filled. The mould is then placed on a special potter's wheel and as it revolves a metal tool shaped to the other surface of the insulator is brought down to the exposed clay. This tool does not rotate and is fixed at a slope such that a pressing action is imparted to the body. By a vertical movement the tool is brought in contact with the clay, thus forcing the latter into the mould, at the same time forming the upper surface to the required shape. This method can only be applied when the lower surface is of such a shape that it will leave the mould, and the upper surface has contours such as can be correctly shaped by the profile tool.

After forming, the insulator is allowed to dry in its mould until sufficient contraction has occurred to make its extraction safe.

Casting. For casting the body is not used in a plastic state, but in the form of a creamy liquid (*casting slip*). The moulds are constructed of plaster of Paris, which, as is well known, takes up water easily. The slip is poured into the mould and allowed to stand for a definite period. Owing to the porosity of the mould the slip adjacent to it is deprived of its water and commences to solidify. The time the slip is allowed to stay in the mould is governed by the required thickness of the insulator, as the longer the time, the thicker the wall of clay against the mould becomes. At the required time the surplus slip is poured from the mould and the deposited clay allowed to dry sufficiently for it to be extracted from the mould. The design of the mould should be such that the clay is allowed to

leave easily when contracting, otherwise fatal stresses will be set up.

Casting, due to the excessive contraction, would have had a very limited application had the only method of reducing the body to liquid form been that of adding water. Fortunately, a peculiar physical phenomenon saves the situation. By the addition of certain alkaline salts and other electrolytes to the body, it is possible to produce a slip capable of being easily poured, which contains very little more water than the plastic body used for turning and jollying.

Drying. The drying of insulators in the clay stage is the same for all three types of manufacture. Special rooms are built for this process in which the temperature, humidity, and ventilation can be adjusted in such a manner as to ensure that drying takes place uniformly throughout the whole mass. Should the outside be allowed to harden before the centre is dry, cracking is unavoidable. This process cannot be speeded up without risk of considerable loss.

Glazing. Until recent years each insulator was fired twice. The first firing was to vitrify the body (the insulator in this condition is said to be in the *biscuit* stage) and the second to fire the glaze. Present-day practice is to have one firing and the insulator is dipped into the glaze before it is taken to the kiln. It is a great assistance to the potter if one end of the insulator can be left unglazed in order that it can stand on this surface. The glaze itself is a clay mixture similar to the body, but with a larger percentage of fluxing material which produces the glass-like finish, and certain metallic oxides to obtain the required colour. Brown is almost the universal colour for outdoor work.

The main purpose of the glaze is to impart a smoother surface to the insulator than is possible were the body left in the biscuit state, thus making the accumulation of dirt deposits more difficult. A secondary but important feature is that a correct combination of glaze and body increases the mechanical strength of the insulator. Glaze is not applied to protect the porcelain from moisture, although this belief is not entirely unknown.

Firing. Firing is the final process of an intricate sequence, and is perhaps the most critical. There are several types of ovens or kilns. The oldest type, which is still the most popular for high voltage insulator work, is known as the *round kiln*.

Many of this type can be seen from the train when passing through the Potteries. A typical example is here shown (Fig. 30) from which it will be seen the fire boxes are placed on the outside of the kiln. The gases, on emerging from the firing zones, split and travel in two directions; part go upwards to the top, then downwards and under the bottom, and from there pass between the outer walls upwards and out. The second part first pass under the kiln bottom, entering the kiln through the floor, moving upwards and then downwards to join with the gases started in the other mentioned direction.

In all types of kilns, the method of filling is generally the same.

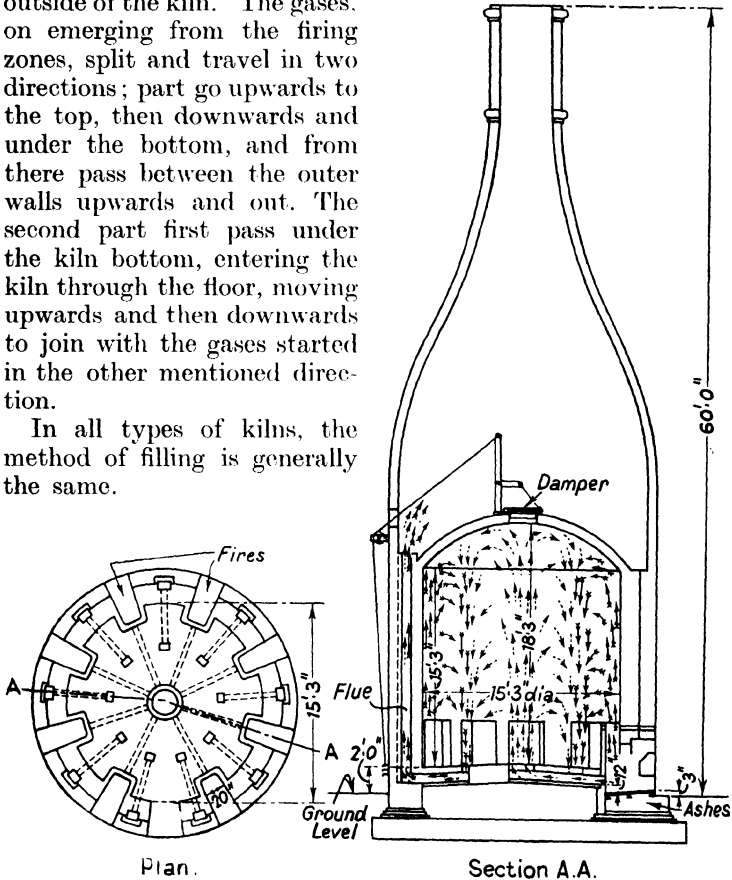

FIG. 30. A ROUND KILN USED FOR FIRING PORCELAINS
(Taylor, Tunncliffe, Ltd.)

The insulators are placed in fire clay receptacles known as *saggers*. Where an insulator has an unglazed end, this surface is used to stand it upon in the sagger. In cases where the article is completely covered by the glaze, three porcelain props known as *stilts* are used to support it. These stilts leave

slight marks similar to those found on the bottoms of domestic plates and saucers. Only light articles can be treated thus, as with heavy pieces the stilts would become embedded to a considerable extent. The saggeres are placed one on top of the other with a ring of fire clay between them to prevent smoke and fire gases entering and contaminating the insulator. In the case of tall pieces such as bushing insulators, the sagger is built up of a number of sagger rings with the fire clay packing at each joint. The water vapour and other gases driven off from the insulator during firing escape through the joints between the saggeres.

The stacking of the saggeres in the kiln is a skilled operation; various types of insulator occupy different positions and the maximum amount of material is packed in, as the firing cost of a partly-filled kiln is as much as a filled one. There may be as many as twenty-four saggeres in a stack; with each sagger containing its average weight of insulators the bottom sagger will have to support approximately 1 200 lb. Failure of a bottom sagger means at the least that its particular stack is ruined, and the fall may involve others. When the kiln is full, the doorway is bricked up and firing commences. Coal is used as the fuel in most cases for round kilns.

An approximate time from starting to fire until the kiln is cool enough to empty (known as *drawing*) is six days. The peak temperature varies between 1 250° C. and 1 350° C. This maximum temperature has to be steadily maintained within a very limited variation for a definite period to ensure complete vitrification. The contraction during firing is 8 to 10 per cent. This is caused not only by the loss of moisture but by the collapse of the pores in the body. The semi-molten flux is the agent which causes this collapse by drawing the particles together, thus forming a non-hygroscopic homogeneous mass. This process is known as *vitrification*.

Although the literal definition of vitrification is "a process of bringing to a state of glass," vitreousness is a term applied to porcelain, understood by the trade to mean a condition produced by the application of certain temperatures on the material used, whereby the latter is fused to a condition that does not permit the entry of moisture. This is the subject of a B.S.I. Specification which defines tests to be carried out to determine this condition.

Whilst the characteristic of vitreousness is most important,

it is essential not to lose sight of the fact that what is of equal importance is the maintaining of other characteristics such as mechanical strength, and the ideal insulator material is one that has a good balance of all the required characteristics in such a way that one is not brought into extra prominence to the detriment of any of the others. As an instance, it would be perfectly easy to produce a porcelain body more of the appearance of glass, but the mechanical strength in such a case would be considerably weakened.

The tests to prove correct firing, and therefore complete vitrification, are sufficient to ensure that this has taken place, since, apart from the pyrometers used to indicate temperatures, tests are made from every kiln on many pieces of porcelain as a further check.

Over-firing is a condition which must be guarded against, as this produces a weakened structure, owing to bloating of the material. This fault, however, is one that is easily observed by visual examination, and ordinary routine checking, as indications of this fault are very obvious in the final inspection. These remarks apply to the body, but the glaze (particularly when coloured glazes are used) also gives an indication of the firing conditions to which the ware has been subjected.

CHAPTER IV

THE DESIGN AND TESTING OF PEDESTAL INSULATORS

WHEN considering the design of any type of outdoor insulator, various requirements emanating from entirely different sources have to be co-ordinated to ensure a satisfactory final result.

Consideration of any one of these requirements alone would ensure complete compliance with that particular phase, but might prejudice the solution of other problems. After a review of all the circumstances, a compromise is usually necessary to obtain a balanced design. These facts should be realized when considering the merits of insulators designed and manufactured by different makers.

The main factors influencing design are—

1. *General Electrostatics.* Dielectric field form, the external and internal potential distribution, equipotential surfaces and refraction.

2. *Weather Conditions.* Rain, snow, ice, atmospheric pressure, temperature variation, fog, mist, and humidity.

3. *Fouling.* Chemical fumes, salt, soot and ash deposits, etc.

4. *Mechanical Strength.*

5. *Manufacture.* Under this heading the fixing of metal parts to porcelain is included, in addition to ceramic problems.

6. *Tests.*

GENERAL ELECTROSTATICS

Until the advent of high voltage transmission, the study of electrostatics was solely an academic subject. At generating voltages considerable liberties could be taken with the dielectric field without loss of power or insulation failure, whereas the magnetic field required careful study to obtain satisfactory results.

Electrical energy flowing along a conductor exists in two forms, electrostatic and electromagnetic, each of which has its own independent field form. The electrostatic energy = $\frac{1}{2} CV^2$. The electromagnetic energy = $\frac{1}{2} Li^2$. The energy is actually stored in these fields which are formed in the space surrounding the conductors. Electrical energy cannot flow

without the existence of both fields. It is the electrostatic field that is of importance in insulator design.

As the electric circuit has been given more consideration than the dielectric circuit by most engineers, an analogy between them may help in defining the terms of the latter.

TABLE II

Electric Circuit	Dielectric Circuit
Current	Flux
Current density	Flux density
Conductivity	Specific inductive capacitance (s.i.c.) or dielectric constant (κ)
Resistance	The reciprocal of s.i.c., sometimes termed <i>elasticance</i>
Magnetizing force	Electromotive force
Magnetomotive force	Voltage per unit length of dielectric circuit, or voltage gradient, or intensity
Magnetic field	Dielectric field

F. W. Peek, Jr., gives an analogy with Hooke's Law, the voltage gradient being substituted for force or stress and flux density for the resulting electrical strain. S.i.c. or κ is then a measure of the electrical elasticity of the material. Thus $l = Lf/E$ where l = strain, L = original length, f = stress and E = modulus of elasticity. The electrical equivalent given by Peek is as follows: $\alpha = D\varepsilon/\kappa$ where α = increase in flux density, D = original flux density, ε = potential stress or intensity, and κ = dielectric constant.

The Dielectric Field. Dielectric lines or tubes of force were first conceived by Faraday to explain the action of force across space. They are therefore known as *Faraday tubes*.

These tubes leave a conducting surface coincident with the radius of curvature at the point considered, or in other words at right angles to the conducting surface at that point. From this it will be realized that the field produced between two parallel plate electrodes will be strictly uniform (if fringing at the edges be neglected); the field being a series of equally spaced straight lines at 90° to the electrodes.

The density and shape of the field flux is influenced by the following factors.

- (a) The s.i.c. of the insulating medium between the electrodes.
- (b) The shape of the electrodes.
- (c) The number of insulating materials of different s.i.c.

between the electrodes and their relative positions with respect to each other.

(d) The shape of the dielectrics.

(e) The potential difference between the electrodes.

(a) **Specific Inductive Capacitance.** The scientific standard for unit s.i.c. is that of a vacuum. Tests have proved, however,

that for all practical purposes air can be considered as having unit s.i.c. The dielectric strength of air remains constant, therefore a definite number of lines of force are required per unit area before breakdown occurs. It has been proved experimentally by a number of authorities that with air at 15°C. under a pressure of 760 mm. the maximum electrical stress it can withstand is 30 000 volts per cm.

(b) **The Shape of the Electrodes.** Electrodes should be shaped so as to avoid concentration of field and to keep the lines of force as far apart as possible, the reduced density thus minimizing the number of highly-stressed regions. Referring to Fig. 31 the fringing can be counteracted by making the plate round and fitting a curved rim of defined radius. The maximum intensity, however, is still at the edge. It is possible to obtain the same breakdown values between two spheres as between two plate electrodes provided the radius of the sphere is the same as that of the curved rim of the plates.

The nearest practical equivalent to a uniform field is therefore that produced between large sphere electrodes. The

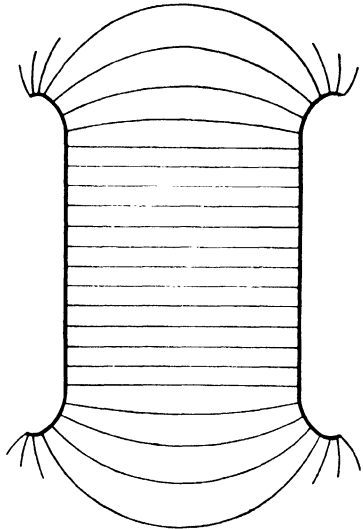

FIG. 31

THE DIELECTRIC FIELD PRODUCED BETWEEN PARALLEL-PLATE ELECTRODES HAVING ROUND EDGES

TABLE III

Diameter of sphere in cm.	6.25	12.5	25	50	100	Needle gap
Disruptive kV.	110	151	171	189	195	Approx. 50

disruptive voltage for the same spacing increases with the sphere diameter. The table on p. 55 gives the spark-over voltage in air between various sizes of ungrounded spheres, the spacing between them being 10 cm. in each case.

This difference in breakdown value of the gap is entirely due to the varying field intensity close to and at the surface of the electrode. The field form between two spheres is shown in Fig. 32.

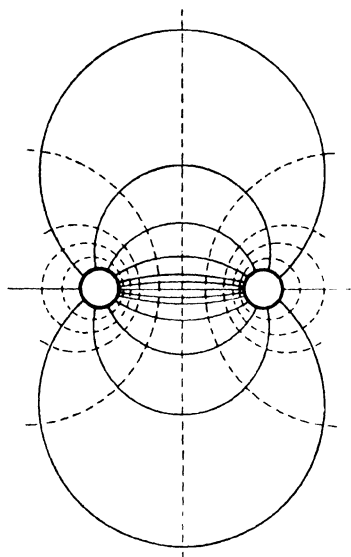

FIG. 32

DIELECTRIC FIELD PRODUCED
BETWEEN SPHERE ELECTRODES

The full lines indicate the shape of the field. The dotted lines show equipotential zones.

With increasing voltage between the electrodes a value is reached when the air adjacent to them becomes stressed to the 30 000 volts per cm. limit, and breakdown of this portion occurs. The smaller the sphere the lower is this disruptive voltage for a given gap.

The failure of a portion of the air in effect alters the shape of the spheres and diminishes the distance between them, thereby increasing the stress in the remaining air and thus causing complete breakdown. When spheres are spaced at a dimension less than their diameter, preliminary breakdown is, in effect, coincident with spark-over. This spacing is seldom exceeded when using spheres for accurate voltage measurement,

although no appreciable corona forms below a spacing of three diameters. In practice it is seldom possible to use large spheres on apparatus, but usually highly-stressed regions can be partially relieved by careful shaping of the electrodes. It is often a help to plot roughly the field form when deciding shapes of both electrodes and insulation.

After a little practice an approximate field can be drawn without calculation or test which will be accurate enough to enable preliminary shapes to be fixed.

METHODS OF OBTAINING DIELECTRIC FIELD FORMS

Mathematical Calculation. Although it is possible to calculate and graphically plot field forms, the lengthy calculations necessary for irregularly shaped electrodes make this method impracticable.

Insulation Filings Method. This method can be used for obtaining the field form from the electrodes only, or from a complete insulator unit. In the former case a sheet of press-board which has been cut to embrace the electrodes is mounted horizontally. The upper surface of the board, which should lie on the axis of the electrodes, is then thinly sprinkled with mica,

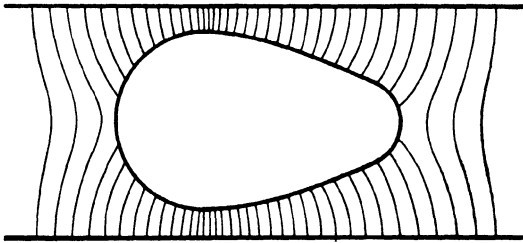

FIG. 33. DISTORTION OF THE DIELECTRIC FIELD BETWEEN PARALLEL-PLATE ELECTRODES CAUSED BY THE INTRODUCTION OF AN EGG-SHAPE PORCELAIN PLACED HORIZONTALLY BETWEEN THE ELECTRODES

asbestos or fibre filings and the required voltage applied between the electrodes. Slight tapping on the pressboard assists the filings to adjust themselves to the field form. In the case of a complete insulator the card is cut to embrace the whole unit.

Single Straw Method. Perhaps the most accurate and convenient method is that originated by Toepler, modifications of which have been devised to obtain an indication of field intensity as well as field shape.

The Toepler scheme uses a straw suspended by silk threads, which, when introduced into the field, adjusts itself thereto, in just the same manner as a steel needle would take up a position in a magnetic field.

A shadow of the insulator and the straw is thrown upon a screen by a suitable projector. By moving the straw into different positions in a plane parallel to the screen and marking its shadow position thereon, the field form can be plotted.

(c) and (d) **The Number and Relative Positions of Different Insulating Materials.** An insulating material having the same s.i.c. as air can be placed between two electrodes without changing the dielectric field form, irrespective of the shape of the material. Should the s.i.c. of this insulation differ from that of air then the stress in the air between the surfaces of the electrodes and the insulation will be altered unless the insulation is so shaped to avoid such an occurrence.

Fig. 33 illustrates the effect on the field form between two plate electrodes by the introduction of an egg-shaped porcelain

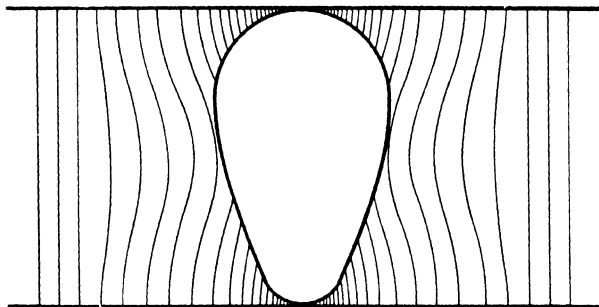

FIG. 34. DISTORTION TO THE DIELECTRIC FIELD BETWEEN PARALLEL-PLATE ELECTRODES CAUSED BY THE INTRODUCTION OF AN EGG-SHAPED PORCELAIN PLACED VERTICALLY BETWEEN THE ELECTRODES

placed horizontally. Fig. 34 shows the modification resulting from the body being mounted vertically.

It will be noted that the lines of force are concentrated in the porcelain and are more dense at the surfaces nearest the electrode. In both cases the disruptive voltage will be lowered by the presence of the porcelain.

The explanation of this phenomenon lies in the difference of the s.i.c. of air and porcelain; thus unit potential produces a greater flux in the porcelain in direct proportion to its s.i.c. At the surface of the porcelain the tangential component of the intensity must be the same in the air as it is in the porcelain.

When a dielectric flux passes from air to porcelain, or vice versa, the flux density D across the immediately adjacent air layer must be the same as that across the immediately adjacent porcelain layer. Therefore, as D is common, there results from the standard equation $D = CV$ the condition

$$C_a V_a = C_p V_p$$

where the suffixes denote air and porcelain respectively. Let the s.i.c. now be represented by the dielectric constant κ , then, if C_p is κ times the value of C_a , from the above equation

$$V_a = \kappa V_p$$

Or, the voltage stress in the air at the surface of the porcelain is κ times as great as the stress in the porcelain at the surface.

Consider the case of a voltage V across a number of dielectrics in series, and suppose the dielectrics to be of constants $\kappa_1, \kappa_2, \kappa_3$, etc., and of thicknesses d_1, d_2, d_3 , etc. Let them be in the form of flat plates of area A , such that their capacitances are given by $A(\kappa_1/d_1); A(\kappa_2/d_2); A(\kappa_3/d_3)$, etc., A being constant. Then, as these are in series, the total capacitance C_0 will be

$$C_0 = \frac{A}{d_1/\kappa_1 + d_2/\kappa_2 + d_3/\kappa_3 + \dots} \quad (3)$$

The voltage V will divide across the various dielectrics in inverse proportion to their capacitances. Thus, the voltage across each dielectric will be

$$V \frac{d_1}{\kappa_1} \cdot \frac{1}{d_1/\kappa_1 + d_2/\kappa_2 + d_3/\kappa_3 + \dots}$$

$$V \frac{d_2}{\kappa_2} \cdot \frac{1}{d_1/\kappa_1 + d_2/\kappa_2 + d_3/\kappa_3 + \dots}$$

$$V \frac{d_3}{\kappa_3} \cdot \frac{1}{d_1/\kappa_1 + d_2/\kappa_2 + d_3/\kappa_3 + \dots}$$

etc.

and the voltage gradients will be

$$\mathcal{E}_1 = \frac{V}{\kappa_1} \cdot \frac{1}{d_1/\kappa_1 + d_2/\kappa_2 + d_3/\kappa_3 + \dots}$$

$$\mathcal{E}_2 = \frac{V}{\kappa_2} \cdot \frac{1}{d_1/\kappa_1 + d_2/\kappa_2 + d_3/\kappa_3 + \dots}$$

$$\mathcal{E}_3 = \frac{V}{\kappa_3} \cdot \frac{1}{d_1/\kappa_1 + d_2/\kappa_2 + d_3/\kappa_3 + \dots}$$

etc.

From the above, it follows that the insertion of a porcelain slab into an air field will result in a stress in the air κ times as great as the stress in the porcelain. In the limiting case of an

infinitely thin air layer between electrode and porcelain, the stress in the air will become κ times as great as would be the stress were the porcelain not present.

Therefore, it will be realized that the higher the κ value of the insulation introduced into the field, the higher will be the stress in the air. It will also be apparent that with a lower voltage than that required to cause flash-over between the electrodes some sections of the air may still be overstressed and local corona formed. This state of affairs can be observed

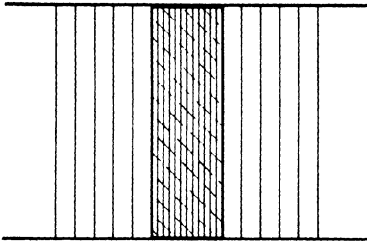

FIG. 35

A BODY WHICH CONFORMS IN SHAPE TO THE DIELECTRIC FIELD PRODUCED BETWEEN ELECTRODES DOES NOT PLACE ADDITIONAL STRESS IN THE AIR SURROUNDING THE BODY

when taking flash-over tests on pin or strain type insulators in a darkened test room. Observation on the amount of corona and at what voltage it commences is used as a guide when comparing insulators of different designs submitted for the same service. Insulators to be so tested are usually mounted on a common base and voltage applied simultaneously.

In Fig. 34 the tangent at any point at the sides is of a nearer relation to the normal lines of force than at a point on the surface of the rounded ends. The field intensity in the air is therefore less at the sides.

If a porcelain cylinder or any other parallel sided insulator is inserted between the plate electrodes, Fig. 35, then the side of the insulator conforms exactly with the field form and no additional stress is placed on the air by the addition of the insulation. It is therefore possible to insert a solid dielectric having a greater s.i.c. than air between any two electrodes without increasing the stress in the air if the solid dielectric is so shaped that it conforms to any one of the Faraday tubes. The importance of this fact and its bearings on the design of pin type insulators was brought to the fore by C. L. Fortescue and S. W. Farnsworth, A.I.E.E. *Transactions*, 1913, page 893.

Shaping of the Main Body of Cap and Pin Type Post Insulators on Electrostatic Principles. Fig. 36 shows the dielectric

field form between a typical cap and pin of a post type insulator. The heavy line on the left-hand side illustrates a suitable body porcelain shaped to conform to a Faraday tube.

Tests have demonstrated that by shaping the porcelain in this manner a flash-over figure of 15 to 20 kV. per inch is obtained. The variation in this value is due to the shaping of the metal parts and the accuracy of the porcelain in conforming to the field.

Switch parts or bus-bars mounted on an insulator also affect the field form, and may reduce the flash-over value although the added metal parts have not shortened the path to earth. The insulator illustrated would be suitable for indoor use, but would have too short a leakage path for outdoor service; rain sheds are therefore fitted.

Theoretical Considerations Affecting the Shaping of Rain Sheds. The chief function of a rain shed is to increase the leakage path of the insulator. The protection of a portion of the insulator from rain is not always strictly necessary, although many designs fulfil such a requirement.

Indiscriminate shaping of sheds may have an undesirable influence on the field and cause other troubles which will be enumerated later.

As it is usually impossible to form sheds to the dielectric field, an arrangement is necessary in which the least field disturbance is caused, and concentration at the sheds avoided. One method of attaining this end is to shape the sheds to conform as nearly as possible to equipotential surfaces between the metal parts.

Equipotential Surfaces. All points in the space surrounding an electrode have definite potentials of their own, these values varying according to their positions in the field. The joining up of all points having the same potential completes what is known as an *equipotential surface*. A thin sheet of metal

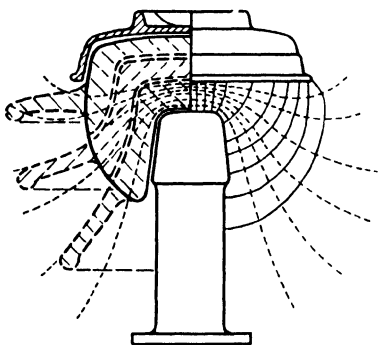

FIG. 36

SHOWING THE DIELECTRIC FIELD FORM AND THE EQUIPOTENTIAL SURFACES BETWEEN A TYPICAL CAP AND PIN, ALSO A BODY AND SHED SHAPE CONFORMING THERETO

shaped to conform to one of these surfaces and inserted in its correct position in the field will not alter the form of the latter.

Such surfaces formed between spheres are shown dotted in Fig. 32. They are at 90° to the dielectric field at the point of intersection and conform exactly with the magnetic field. Fig. 36 shows in dotted lines the equipotential lines between the cap and pin, also rain sheds shaped to conform as nearly as practicable to these surfaces. By this arrangement the field

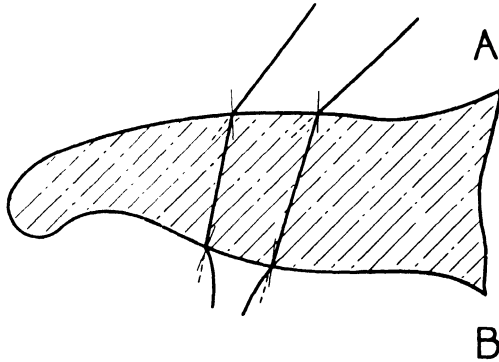

FIG. 37. SECTION OF A PORCELAIN RAIN SHED SHOWING DIFFRACTION

form will be but slightly affected when the surface resistance of the sheds is lowered by rain or fouling, as all points along the surface of any shed are practically at the same potential.

A shed so shaped that its surface cuts a number of equipotential surfaces is not necessarily wrong, as the stress between the various sections may be of a safe value.

Diffraction. The actual section of a rain shed should be of such a shape that diffraction is reduced to a minimum. As already stated, lines of force leave a conductor at right angles to its surface, but they may strike the surface of a dielectric at any angle. Thus it is possible for a dielectric to be shaped so that concentration of lines of force is affected at any desired part, just in the same way as a glass lens may be shaped to concentrate light rays by refracting the rays through the required angle. So also may the lines or rays be scattered by suitably shaping the dielectric or lens.

Fig. 37 shows this effect on a rain shed so shaped as to diffract two lines of force so that concentration is obtained.

The portion of porcelain enclosed by these two lines is thus subjected to an unequal stress, while the air adjacent to side *A* is not so highly stressed as is that adjacent to side *B*. If, therefore, the air field intensity on side *A* is just below the breakdown value, that on side *B* will exceed it and local discharge will occur.

Spacing of Rain Sheds.

Having fixed suitable rain shed shapes for any particular unit their effectiveness can be discounted by incorrect spacing. Referring back to Fig. 35, the addition of small corrugations, Fig. 38 (left-hand half), lengthens the leakage path considerably, but in so doing increases the stress in the air adjacent to the insulator. The spark-over value is but slightly increased although a considerable increase in leakage path has been obtained. The right-hand section gives the same length of leakage path as that on the left, but causes far less field distortion, and obtains a corresponding increase in spark-over value. The crowding together of rain sheds intensifies the condition illustrated as long as thin air sections are formed which become highly stressed. The long leakage path obtained by this practice is of little practical use and will result in producing a unit less efficient in service than one with a smaller number of well-spaced sheds.

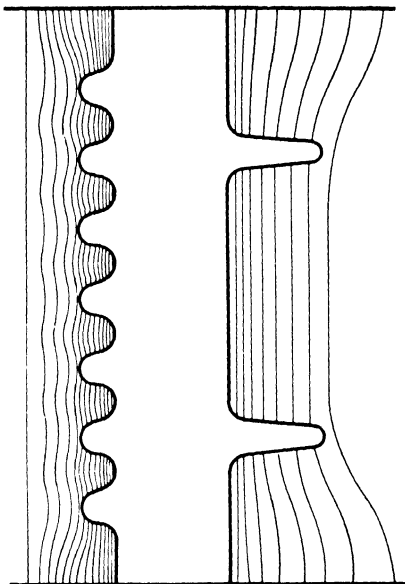
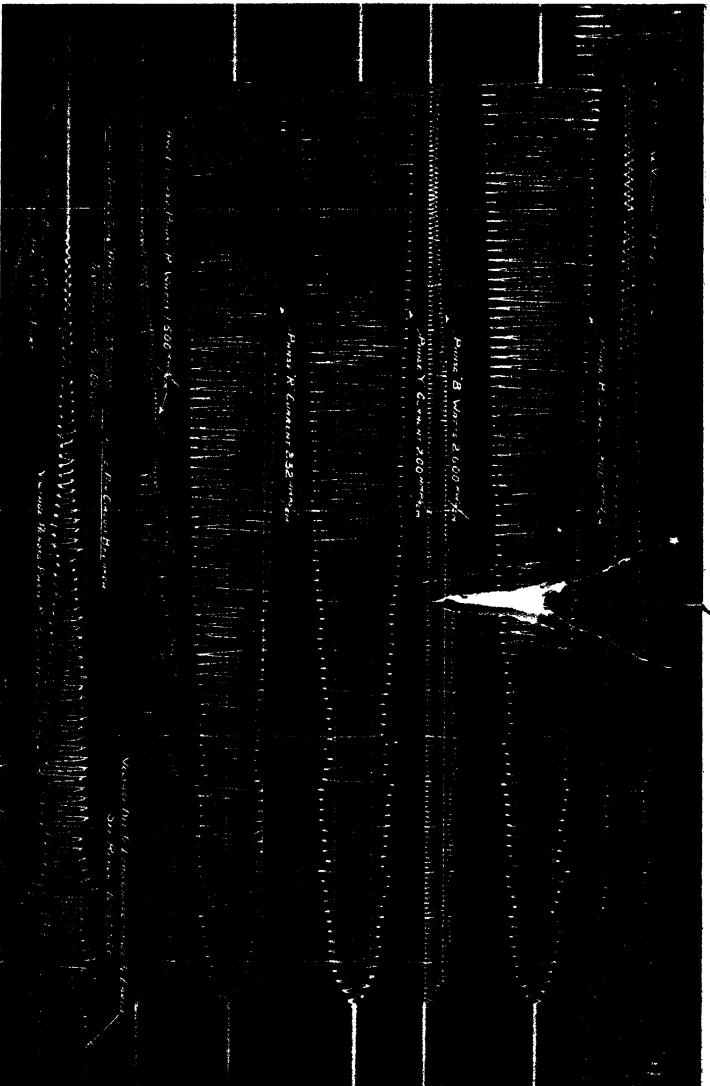

FIG. 38. SECTION OF A PORCELAIN INSULATOR SHOWING ON THE RIGHT THE CORRECT AND ON THE LEFT THE INCORRECT METHOD OF INCREASING THE LEAKAGE PATH

An insulator constructed to obtain a long leakage path by crowding will often have a high wet-to-dry spark-over ratio when tests are made on a clean unit, thereby giving a false impression of its service safety factor. This high ratio is caused by the large percentage of porcelain protected from rain.

An insulator constructed to obtain a long leakage path by crowding will often have a high wet-to-dry spark-over ratio when tests are made on a clean unit, thereby giving a false impression of its service safety factor. This high ratio is caused by the large percentage of porcelain protected from rain.

Dry and Wet Spark-over Values of Pin-Type Insulators. Provided the generally accepted proportions of a pin-type



(1-5771)

FIG. 82. OSCILLOGRAM OF RUPTURING TESTS ON THE AIR-BREAK SWITCH SHOWN IN FIGS. 53 AND 54
 (Mitsubishi Electric Research Dept.)

64 OUTDOOR HIGH VOLTAGE SWITCHGEAR

insulator are observed, the number and shape of the rain sheds will have little effect on the dry spark-over voltage of a clean unit. Fig. 39 shows a series of curves giving the dry spark-over voltage against the "tight string" length between live metal and earth of various types of insulators. These curves were

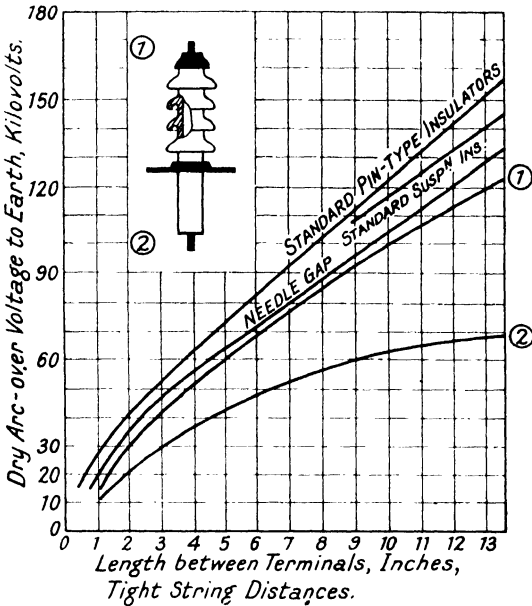

FIG. 39. DRY SPARK-OVER VOLTAGE OF VARIOUS TYPES OF INSULATORS
Lapp Insulator Co., U.S.A.

issued by the Lapp Insulator Co., Inc., U.S.A. The pin insulator curve has been checked by the authors with various makes of units and found to give a very good approximation.

Wet spark-over values are influenced by rain-shed design. Provided clean insulators are tested, a unit having a large portion of porcelain shielded from rain will give a higher wet spark-over value than a unit of similar size but of a more open design.

As already pointed out, a high wet-to-dry ratio is not a guide to insulator efficiency.

Rain tests taken in line with B.S.S. No. 137 on a representative collection of post type insulators show that the wet spark-over voltage may be between 65 per cent to 75 per cent of the dry spark-over.

Puncture Values of Cap and Pin-Type Insulators. The increased flash-over voltage of an insulator obtained by adding

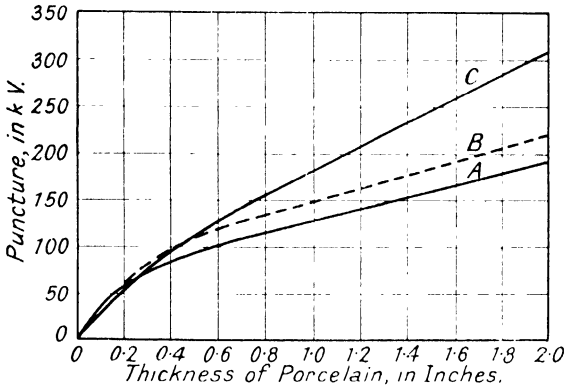

FIG. 40. VARIATION OF PUNCTURE VOLTAGE WITH PORCELAIN THICKNESS

Curves "A" and "B" embrace safe figures for pin type insulators. Curve "C" gives values for uniformly stressed field.

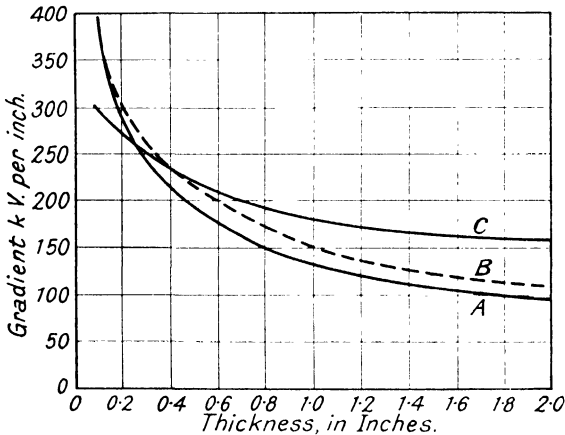

FIG. 41. PUNCTURE VALUES IN kV. PER IN. FOR VARIOUS THICKNESSES OF PORCELAIN

Curve designations as Fig. 40.

rain sheds is limited by the puncture voltage through the porcelain between the cap and pin, as spark-over must occur at a value lower than the puncture value under all service conditions. The ratio of spark-over volts to puncture volts may

vary with different insulator designs. This is due to other design features (such as mechanical strength) affecting the thickness of porcelain employed.

On 50 periods the puncture value should not be less than 130 per cent of the dry spark-over; in some cases it may be found to be as high as 190 per cent.

Due to ceramic difficulties it is uneconomical to manufacture this type of insulator for voltages above 22 or 33 kV. in one piece. It is therefore customary to construct units in two or more pieces, each piece being arranged to form a rain shed in addition to a portion of the main body. Fig. 36. This arrangement aids the technical design in so far as some measure of control is obtained on the voltage gradient of the porcelain between the cap and the pin. The cement joints and the metalwork acting as the plates, and the porcelain as the dielectric, of condensers in series, the capacitance of each condenser should be as far as possible equal.

With this arrangement the thickness of any section seldom exceeds one inch.

Fig. 40 gives the variation of puncture voltage with porcelain thickness.

Fig. 41 gives the puncture gradient value in kilovolts per inch for various thicknesses of porcelain.

Curves *A* and *B* in these illustrations embrace values which can be used safely for pin-type insulator design.

Curve *C* gives values for a uniformly stressed field, i.e. between flat plates with rounded edges.

When system voltages exceed 50 kV. it is usual to employ multiple insulator units. Examples of such assemblies for use on 132 kV. are drawn in Fig. 42.

WEATHER CONDITIONS

Rain. Rain is of definite service to insulators due to its cleaning effect. Its two important properties in connection with insulator spark-over values are precipitation and resistivity.

Precipitation. Spark-over voltages fall rapidly with increasing intensity up to a rainfall of approximately 3 mm. per minute, after which further increase has but little influence. The standard of 5 mm. (0.2 in.) per minute adopted by Britain and America is therefore a safe figure and is actually in excess

of any rainfall experienced in service except under unusual conditions.

Resistivity. Resistivity provides a more awkward problem than precipitation. The variation in rain-water resistance is caused by the presence of impurities either in solution or suspension and widely different values are obtained.

At resistances of approximately 5 000 ohms per cm. cube or

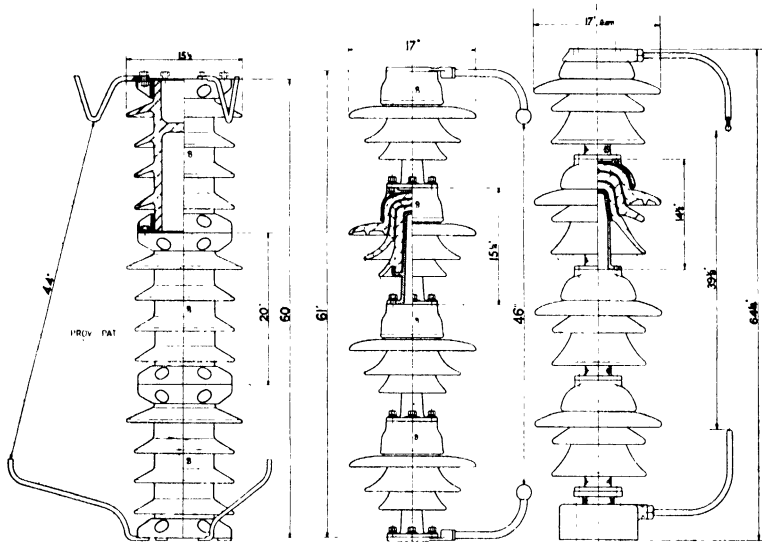

FIG. 42. POST INSULATORS BUILT UP OF SEVERAL SEPARATE UNITS, EACH FOR 132 KV.

below, the impurity content is liable to influence flash-over values, quite independently of its effect on the water resistance.

Fig. 43 shows the variation in spark-over of a particular insulator with varying water resistance. The general shape of this curve is only approximately similar for all insulators, as the shape of the unit has a definite influence on the values obtained. It is therefore impossible to draw a curve of percentage spark-over against water resistance for use with various designs of insulators. Comparisons of wet spark-over values should only be made when the units concerned have been tested with water of the same resistivity.

Fog. Fog and mist are the worst weather conditions for

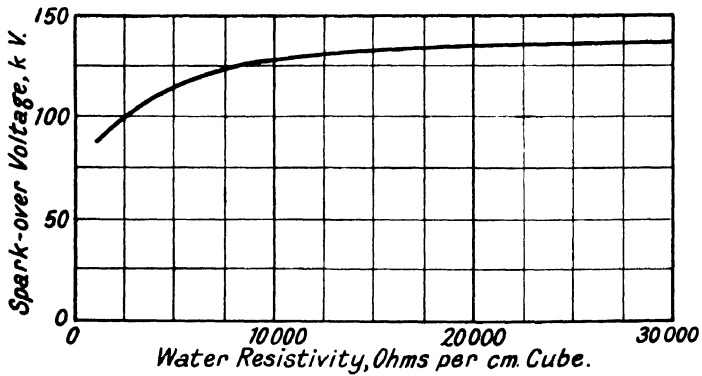

FIG. 43. VARIATION IN SPARK-OVER OF A PARTICULAR INSULATOR WITH VARYING WATER RESISTANCE
 ("The Testing of Porcelain Insulators," Goodlet, *I.E.E. Journal*, 1929.)

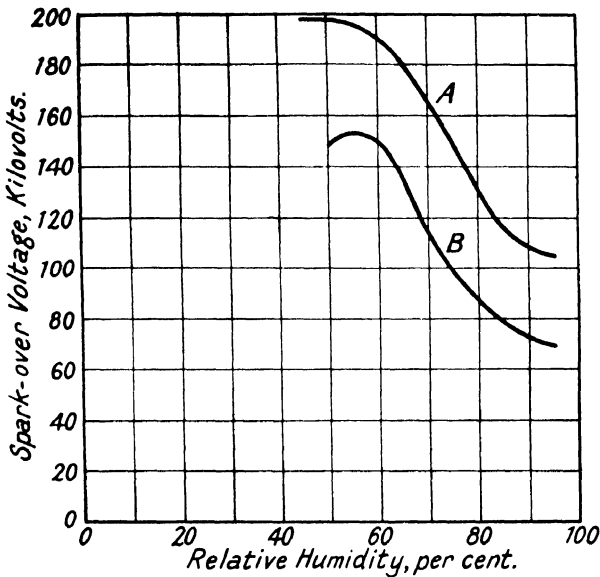

FIG. 44. SPARK-OVER VOLTAGE OF SMOKE-FOULED INSULATORS AS A FUNCTION OF RELATIVE HUMIDITY
 (Goodlet and Milford, *International Conference, Paris*, 1929.)

insulators and are often the final means of causing spark-over. They envelop the complete unit, carrying moisture to the whole surface. Portions of the insulator that are dirty are thereby rendered damp and more conductive. Electrostatic precipitation (see page 71) is encouraged, and the foreign matter carried in suspension in the enveloping fog is drawn to the insulator surface, which further decreases the surface resistance.

Humidity. Fig. 44. Provided the relative humidity does not exceed 60 per cent, spark-over troubles even on fouled units are few. Between 60 and 100 per cent spark-over values fall rapidly. (Refer also to Chapter on Tests.)

Wind. The effect of wind can be either beneficial or detrimental. A large percentage of the dust and dirt that settles on exposed surfaces by the aid of gravity or light breezes is removed by wind.

Enclosures and hollows formed in the insulator construction reduce the wind velocity and cause eddies which build up impurity layers in these seemingly protected areas. These surfaces are not exposed to the cleaning effect of rain in many cases.

It is well known that wind passing over industrial areas, sandy plains, the sea, etc., will collect and carry with it considerable quantities of foreign matter. A prevailing wind of this type will build up a heavy deposit on one side of an insulator during a dry spell, particularly if some of the ingredients are of an adhesive nature. This deposit may be such that on the arrival of rain, which may be accompanied by wind from this same direction, the cleaning effect will not be sufficiently rapid to avoid flash-over.

Atmospheric Pressure and Temperature. The variation of each of these conditions has a marked effect on insulator spark-over. The fluctuation is, however, small when compared with the effect of fog and rain, and is of more importance during testing than in service.

FOULING

Deposits of Dirt, Salt, Tar, etc. The available data on the composition of air impurities is very limited. One official report on the subject is issued by the Advisory Committee on Atmospheric Pollution (Air Ministry). Quantitative figures

and constituent impurities in the atmosphere at various parts of the British Isles are given. A summary of this information has been published. This information has a limited use to insulator designers for two reasons.

1. The apparatus used for collection retained all solid matter, therefore the deposit recorded for a given period has no relation to that collection by an insulator which is scoured by wind and rain. It has been suggested that not more than 5 to 10 per cent of the total precipitation helps to form a permanent deposit.

2. There are certain special cases which are met with where the conditions are local and of a more severe nature than would be considered typical for the district in question. Two such examples are—

An outdoor station installed alongside a main power station, the latter having short smoke stacks. The prevailing wind may be from the stacks towards the outdoor station. (Several cases of this type can be cited.) Under such conditions abnormal tar, ash and grit deposits are encountered, especially where pulverized fuel is used.

An outdoor station feeding a cement factory. In this case the fine cement dust deposited on the insulators is formed into a hard coating by the action of a humid atmosphere, fog or rain. Such a coating is particularly conductive when wet and extremely hard to remove.

Types of Deposits. When considered purely from the insulator standpoint, deposits can be segregated into three main classes. Owing to the variety of ingredients contained therein, all of them are hygroscopic, their conductivity increasing with water absorption. Deposit "C" suffers least from this trouble.

Class "A." Dust of a non-adhesive nature easily removed by wind and rain is common to all situations. When this is the only deposit its influence on insulators can be ignored.

Class "B." Adhesives soluble in water and therefore removable by rain. The principal ingredient in this category is salt deposited in crystal form by wind and sea fog in coastal districts. Its natural attraction for moisture, and adhesive property when damp, aids the building of a particularly objectionable deposit as, apart from adhering to the porcelain itself, it captures a percentage of deposits "A" and "C." Heavier deposits are collected in districts adjacent to rocky coasts. This is due to the spray caused by the sea against the rocks

being greater than that from the sea breaking on a sandy beach.

Class "C." Adhesive deposits not soluble in water. Trouble from this deposit is principally confined to industrial districts where tar carried in the smoke-laden atmosphere forms the main deposit. Its sticky nature aids its combination with both classes "A" and "B."

An industrial area near the coast will be troubled by a combination of all three types.

The Effect of Electrical Forces on Insulator Fouling. Although gravity and wind play their part in building up a surface deposit, electrical forces also contribute.

When the potential applied to an insulator is such that discharges cannot occur, a deposit is built up by the attractive properties of the field. This process is slow and will accumulate the thickest coating where the field intensity is highest. These portions of high intensity are usually on the underside of the sheds.

In cases where the applied voltage may cause local electrical discharge either continuously or under certain weather conditions, such as fog, the building up of a deposit is appreciably accelerated by the electric wind created. The dirt is precipitated on the surface adjacent to the spark.

The action is identical with that used for air purification by electrostatic precipitation, and similar nitrous solutions are formed by the action of the brush on the impurities. These products are particularly adhesive and aid tenacity.

This phenomenon, known as *ionic bombardment*, occurs with any electrical discharge. In the insulator case, the stream of ions leaving the brush collides with air molecules and sets them in motion. This exodus from the surface of the insulator causes an inrush of dirt-laden air.

With the building up of the deposit local stresses increase, thus intensifying the discharge, accelerating the attraction of dirt and further shortening the leakage path.

Mist and fog aid the process by decreasing the resistance of the fouled surfaces, and complete flash-overs are more frequent under such conditions. These failures occur in many cases at normal working pressure. Mr. P. J. Ryle gives the experience of the Newcastle-upon-Tyne Electric Supply Co., Ltd., England, with a 66 kV. line which shows that fouled insulator strings having a wet flash-over of 175 kV. when clean, have flashed

over at normal working voltage (38·2 kV. line-to-earth) under fog or drizzle.

INSULATORS DESIGNED FOR FOULED POSITIONS

The expense incurred by shut-downs due to dirt deposits and the cost of manually cleaning insulators has resulted in the design of special insulators for fouled positions. Several entirely different types have been produced.

Owing to the difficulty of framing tests that will accurately establish the efficiency of insulators with various types of fouling, no standard specifications have as yet been set up.

The number of organized tests made in service to establish data are far less than would be expected. This is due to the difficulties encountered when experimenting with service lines. Certain power companies have solved this problem by installing a test rack on which experimental insulators are mounted. Voltage is applied by a fuse protected tapping from the transmission line.

Service tests must of necessity extend over long periods, and artificial fouling has been resorted to by certain investigators in order to accelerate results.

Unfortunately only a limited number of reports on such tests have been published, therefore available data does not cover experience on all the known conditions.

Protected Leakage Path Type. The first types of insulator to be erroneously called "Fog type" were designed on the "long protected leakage path" principle. Their advocates claim that such units are the logical development from the normal, well proved pin-type insulator. The reasoning underlying their design is that an insulator is virtually a high resistance placed between live metal and earth. The value of this resistance will vary according to the foreign matter present on the insulator surface. As it is impossible to prevent fouling the obvious remedy is to increase the length of the leakage path sufficiently to counteract the loss in surface resistance. This can be achieved by using insulators of a higher voltage rating. This method is expensive, as the price of units rises rapidly from 33 kV. upwards, and normal design does not provide the maximum leakage length obtainable with a given total volume.

Figs. 45 and 46 show two examples of insulators designed

on the long leakage path principle. The first type obtains its additional creepage by undershed projections, while the second is a standard unit fitted with an umbrella top shed.

As surface resistance is a function of area, and not merely of length, an accurate comparison between insulators cannot be made by using leakage path lengths; the main virtue of this type of insulator being increased resistance. A factor known as the *leakage resistance form factor* has been evolved to check this value.

Resistance Leakage Form Factor of Insulators. Consider a unit square on the surface of an insulator. The area intervening

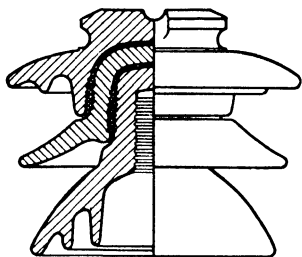

FIG. 45. SEA-FOG PIN-TYPE INSULATOR
(Bullers, Ltd.)

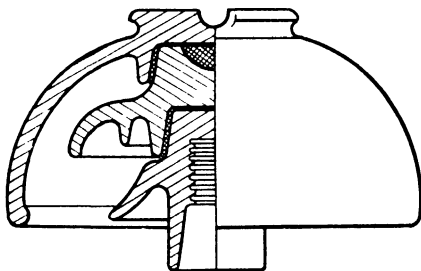

FIG. 46. FOG-TYPE INSULATOR
(Ohio Brass Co., U.S.A.)

between two opposite sides of this square will have a given resistance dependent upon the quality and nature of the surface. Let this value = K .

Because the square chosen is of unit area, the value K may be considered as the specific surface resistance for the material. The total surface resistance will depend upon how many unit squares there are over the total surface of the insulator.

Let N be the number of equivalent unit areas placed together on the surface of the insulator in a line between electrodes. Then, because they are electrically in series, the resistance will be NK .

Let m be the number of equivalent unit areas placed together in a ring on the surface of the insulator, and concentric with the insulator axis. Then, because they are electrically in parallel, the resistance of the ring will be $K \times 1/m$. The number m in a ring will vary according to the position of the ring on the surface. Let M be the value for the mean ring. Then the total number of unit areas over the surface will be MN ,

cleaning from two to four times a year, substituting Lapp fog units has eliminated cleaning entirely. In severe cases, where

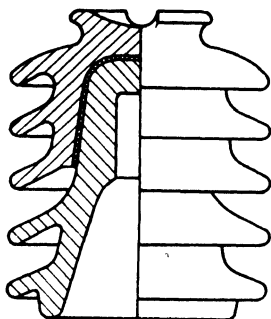

FIG. 47
FOG-TYPE INSULATOR
(Lapp Insulator Co., U.S.A.)

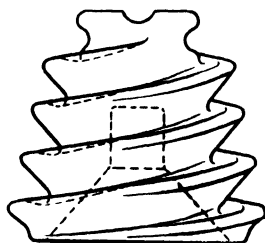

FIG. 48
RAIN-WASHED INSULATOR
(Jeffery-Dwitt Insulation Co., U.S.A.)

normal insulators were cleaned every four to six weeks, Lapp units required cleaning once or twice a year.

Disadvantages of Rain-washed Insulators. These are—

1. The closely-spaced rain sheds create wind eddies and the resulting fouling on their under surface.

2. The sheds being of the same diameter and closely spaced cause sections to be short circuited by rain drips.

An insulator on similar lines to the Lapp unit but modified to avoid the above two objections is shown in Fig. 48. The rain sheds consist of two spiral inverted skirts. In the insulator shown, each spiral has two full turns. By inverting the shed shape the whole surface is exposed to rain. Dripping between sheds is avoided as the rain-water flows down the spirals.

A further type falling within the category of rain-washed insulators is shown in Fig. 49. This type, which originated in Germany, was primarily designed for use with isolating switches, its mechanical construction being such that high torsional and bending strengths are obtained. Its shape is similar to the top porcelain of a bushing insulator. Experience has proved that

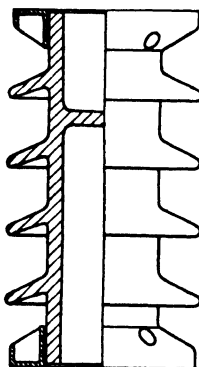

FIG. 49
PEDESTAL
INSULATOR
(Steatite & Porcelain
Products, Ltd.)

bushings are less affected by fouling than pin-type insulators, the explanation again being open design and large areas exposed to wind and rain. The top and bottom metal caps are identical, and the body shape conforms approximately to a Faraday tube.

The Choice of Insulators for Fouled Conditions. The electrical design of insulators has been dealt with at some length owing to its importance in high voltage engineering. The most difficult problem, and one on which authorities differ, is, perhaps, the choosing or designing of an insulator for a particular installation where fouled conditions are prevalent. This section is included in the hope that it will assist engineers faced with such a task.

The problem in all cases is to maintain a resistance to earth of such a value that the leakage current will not attain a value sufficient to cause flash-over.

(The symbols for the various deposits described on pages 70 and 71 are used below.)

(1) *Where the main deposit is "A."* In these cases any reputable maker's standard unit could be used. The dry and wet flash-over voltages should not be less than those recommended in B.S.S. No. 137.

(2) *Where the principal deposits are "A" and "B," high humidity is common, and long periods of dry weather experienced.* In such a case there will be periods when the whole surface of the insulator is fouled. Under fog or high humidity, this surface will be rendered conductive, its resistance varying inversely as the deposit thickness.

To cater for this condition a long leakage path will be required, the design being such that the deposit is as nearly as possible evenly distributed over the whole surface.

When rain falls after a long dry spell the surfaces on which it falls will be rendered highly conductive until such time as the deposit has been washed away. The resistance of the rain will also be lowered due to its combination with the deposit. To meet this requirement a sufficient area of porcelain must be protected from the rain to maintain insulation with the exposed portions short-circuited.

The best insulator would appear to be one constructed with a body shape conforming to a Faraday tube, and the sheds lying approximately on equipotential surfaces. Such a construction avoids uneven coating and prevents field distortion

under rain. Under-shed corrugations would help provided they did not distort the field or form wind traps. The rain sheds must be such that water drips cannot short-circuit protected sections. This can be accomplished either by varying the shed diameters or spacing them far enough apart.

The bottom shed should be as close as possible to the pin without causing undue air stress. If shaped to approximate an equipotential surface such a shed will be practically parallel with the pin and of small diameter throughout its entire length. Such a shed will have a high surface resistance factor since resistance increases with decreasing area; moreover it will be well protected from rain.

Periodical hand cleaning will be necessary, therefore all parts must be accessible. The length of leakage path can only be determined from knowledge of the amount of components of the deposit. Most cases will be met by installing units two sizes above those recommended in B.S.S. No. 137. The insulators shown in Figs. 45 and 49 are two examples of suitable shapes. The following table gives a comparison between the spark-over values of two insulators of different make put forward for the same service voltage. Both were tested under identical conditions. Insulator "A" complied with the general requirements set forth above.

TABLE IV

Insulator Letter	Leakage Resistance Factor	Dry Spark-over 50% Humidity No Deposit	Spark-over with 0.007 g. Salt Deposit per sq. cm. Surface		
			60% Humidity	80% Humidity	95% Humidity
A	1.35	133 kV.	138 kV.	73 kV.	58 kV.
B	1.6	170 kV.	168 kV.	40 kV.	22 kV.

(3) Where the principal deposits are "A" and "B" and rain is frequent throughout the year. This condition will be found more common than (2), and fortunately is less arduous.

The insulator recommended for condition (2) could be utilized but good results would be obtained by installing one of the self-cleaning variety. In certain cases hand cleaning would then be eliminated.

4. *When deposits "A" and "C" are encountered.* In this case the problem is to obtain as long a period as possible between hand cleaning operations as no appreciable help will be afforded by rain.

A standard type of insulator would be suitable provided it complied generally with the requirements specified for condition (2). Particular attention should be paid to cleaning accessibility, as deposit "C" is very adhesive. It is often necessary to use a metal sponge (pan scrubber) to remove the more obstinate varieties. For this reason under-shed corrugations should be avoided.

5. *Where all three types of deposit are encountered.* Here again the surface is rendered conductive with damp. Rain will remove deposit "B" and in so doing carry away a proportion of deposits "A" and "C." This cleaning action of rain will vary according to the proportions of "B" and "C." Where "B" predominates and rain is frequent, the self-washing type of unit will be most suitable. When "C" has the bigger percentage, or when long dry spells are experienced, the type of insulator recommended for condition (2) would be preferable.

MECHANICAL STRENGTH AND MANUFACTURE

From the information given in Chapter III it will be apparent that consideration of porcelain manufacture will not only ensure freedom from ceramic trouble but will, as a rule, mean a cheaper insulator.

The principles recognized when designing cast iron parts can in general be applied to porcelain. Rapid changes in section, sharp corners and edges, and intricate shapes are to be avoided.

Shed curvature should be as liberal as possible in order to avoid hollows being formed should settling occur during firing. Most sheds are placed inverted in the sagger in order that they may rest on their unglazed top. (Fig. 51.)

The demand for unnecessarily fine dimension limits increases the number of insulators to be rejected, thereby raising production costs. Most manufacturers are prepared to accept a limit of $\pm 2\frac{1}{2}$ per cent as a standard tolerance. This limit is satisfactory for most purposes. In cases where grinding is resorted to, such as at the ends of a bushing porcelain, Fig. 159, any desired limits can be obtained. Porcelain grinding is, however, slow and expensive, and a reasonable tolerance will

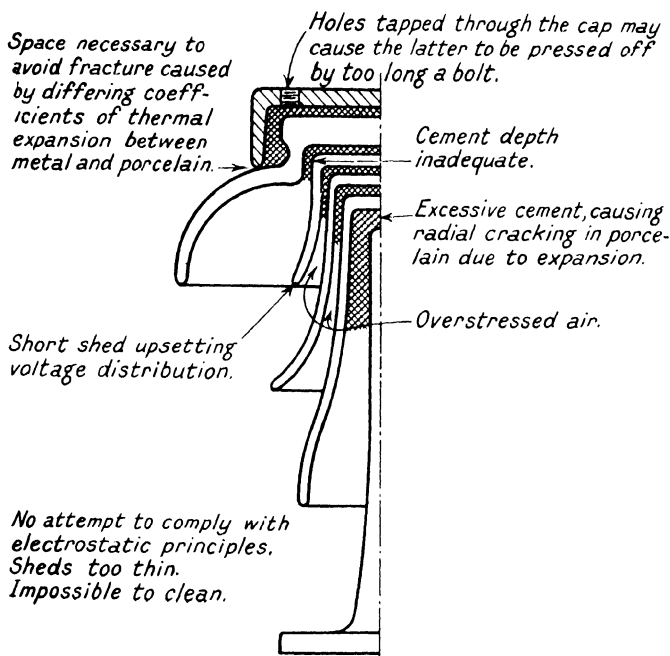

FIG. 50. SECTION OF A CAP AND PIN-TYPE INSULATOR ILLUSTRATING VARIOUS DEFECTS

All points have been taken from actual examples. The drawing is exaggerated to emphasize the defects.

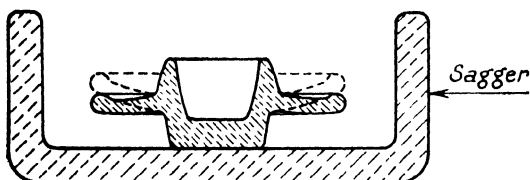

FIG. 51. ILLUSTRATING THE SAG OF THE PORCELAIN SHED THAT MAY RESULT IF SUFFICIENT ALLOWANCE FOR SETTLING IS NOT MADE

mean a slightly lower price. Such tolerances are usually possible, as grinding is primarily to provide a true flat surface for jointing. When necessary, a tolerance of plus or minus 0.015 in. can be worked to.

Roughing or Knurling. The method used for preparing a porcelain surface to receive cement varies with different makers, and has a marked effect on the mechanical strength of the unit. The cheaper method is to groove or knurl the insulator while in the clay stage, and leave this portion unglazed. The cross-section of the insulator is thereby reduced unless the porcelain is thickened where knurling is required.

It is not generally known that glaze can add materially to the mechanical strength of porcelain. Additional layers are sometimes applied to stressed sections for this reason. A roughing which does not necessitate an unglazed surface is therefore preferable, and certain makers glaze over diamond knurling.

Perhaps the most popular roughing is known as *sand glazing*; it was first introduced by the Ohio Brass Co., U.S.A. This process affixes porcelain granules of predetermined size to the surface of the insulator by means of special glaze, there being one layer of glaze next to the insulator and one over the granules. The final result is similar in appearance to builders' pebble-dash in miniature.

Cementing. Until recent years the frequent failure of outdoor insulators was accepted as unavoidable. Investigation proved that few failures were due to porous porcelain but that the principal cause was expansion of the cement jointing material, and the use of poor cement. Research on cementing by various authorities has established Portland cement as one of the most suitable materials for this work, provided the necessary precautions to allay expansion are taken.

There are three accepted causes of expansion—

1. The maturing time of normal Portland cement may extend over several years. Expansion may take place during such a period. The known failure of large numbers of insulators after a period of several years trouble-free service would seem to prove this theory.

2. Portland cement will expand if allowed to absorb water.

3. The coefficient of thermal expansion of cement and iron is higher than that of porcelain. The range of temperatures experienced in many countries is sufficient to cause failure from

this cause unless preventive methods are applied. The present methods used to eliminate expansion failures are—

Cement and Sand Mortar. By mixing a percentage of sand (usually not more than 50 per cent) with the Portland cement, a reduction in expansion can be obtained, as sand is an inert material.

Resilient Coatings. The coating with a resilient material of all porcelain and metal surfaces to be cemented together, in combination with steam curing of the cement, has proved,

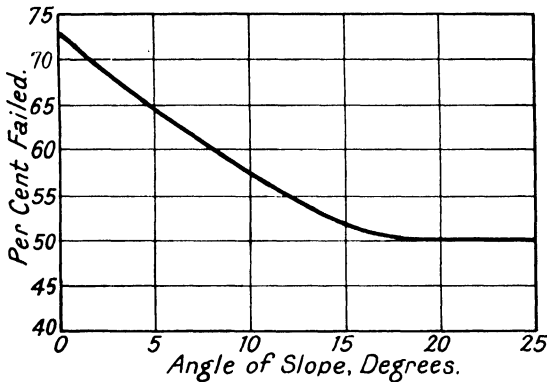

FIG. 52. A RECORD OF FAILURES FOR PORCELAIN TEST CUPS CEMENTED TOGETHER, THE SLOPE OF THE CUP SIDES VARYING

The per cent failure is the average of all results obtained with each particular slope studied, i.e. whether with or without resilient coatings or whether cement or mortar was employed (*E. H. Fritz.*)

during test and in service, completely to cure expansion troubles. A bitumen paint is commonly used. Its consistency and the thickness of the coat is critical. While sufficient thickness is necessary to buffer expansion, an excess will have a detrimental effect on the mechanical properties of the insulator.

Steam Curing of Cement. This process claims to accelerate the expansion of the cement at a high temperature while it is in a weak state, thereby preventing maturing expansion in service.

Insulators to be treated are placed in the curing oven as soon as the cement has hardened sufficiently to allow of careful transport. The oven is maintained at a definite temperature by blowing live steam into it from nozzles situated along the top and bottom of two sides. The curing time varies with different makers, 36 hours being an average. The total time

from commencing to cement until the insulator is ready to be dispatched is approximately four days, which is ten days less than the old method of water setting.

No matter what cementing method is used, exposed cement should be carefully painted with a reliable waterproof paint.

Shape of Sections. The shaping of sections to be cemented together can in many cases reduce the mechanical stress caused by expansion. Fig. 36 shows a pin-type insulator so designed. The conical shape of the cementing surfaces in this case reduces the tensile stress component on the porcelain should the cement expand. The results of a series of experiments to prove this principle is given by E. H. Fritz, Fig. 52.

The angle used in practice is critical, and is governed to some extent by the method used for roughing the cementing section of the porcelain. Too steep an angle will obviously affect tensile strength; 15° is suggested as a maximum for general use.

The space allowed for cement should be such that its maximum thickness does not exceed $\frac{3}{8}$ in. An average thickness is $\frac{1}{8}$ in.

Mechanical Design of Insulators. In order to assist in the mechanical design of units, the physical properties of porcelain and Portland cement are given.

TABLE V
PORCELAIN

Ultimate compression strength	40 000 lb. per sq. in.
Ultimate tensile strength on specially shaped test pieces	5 000 to 7 000 lb. per sq. in.
Ultimate tensile strength figure to be used in insulator design*	2 500 lb. per sq. in.
Ultimate shear strength	3 000 to 6 000 lb. per sq. in.
Specific gravity	2.3
Modulus of elasticity	10×10^6 lb. per sq. in.
Coefficient of thermal expansion	0–100° C. 4.16×10^{-6}
Specific inductive capacitance	5.4 to 5.8
Thermal conductivity	2 to 2.5 $\times 10^{-3}$ g. cal. per sq. cm. per sec.

TABLE VI
STEAM-CURED PORTLAND CEMENT (NEAT)

Ultimate tensile strength	1 000 to 1 500 lb. per sq. in.
Ultimate compression strength	5 000 lb. per sq. in. approx.
Ultimate shear strength (pure shear)	3 000 to 4 000 lb. per sq. in. approx.

* It is not possible to obtain in practice mechanical strengths proportional to figures obtained on test pieces, owing to the difficulty of obtaining a grip on the porcelain, which avoids concentration of stress.

TABLE VII
VARIATION OF DRY SPARK-OVER VOLTAGE OF DIFFERENT INSULATORS OF THE SAME DESIGN

Insulator No.	1	2	3	4	5	6	7	8	9	10
Dry Spark-over Voltage (kV. effective)—Mean of 10 observations	114.9	106.4	98.5	104.9	95.1	95.0	95.8	101.8	98.7	103.4
Deviation kV.	+13.45	+4.95	-2.95	-3.45	-6.35	-6.45	-5.65	-0.35	-2.75	+1.95

Mean of the means on individual units = 101.45 kV.

The average deviation from the mean is ± 4.8 per cent, while the maximum deviations are $+13.25$ per cent and -6.35 per cent.

(From a Paper by B. L. Goodlet "Testing of Porcelain Insulators.")

TABLE VIII
VARIATION OF WET SPARK-OVER VOLTAGE OF DIFFERENT INSULATORS OF THE SAME DESIGN

Insulator No.	1	2	3	4	5	6	7	8	9	10
Wet Spark-over Voltage kV. (Mean of 10 observations)	69.2	69.8	68.0	67.0	73.0	67.2	65.3	69.9	68.6	66.6
Deviation kV.	+0.74	+1.34	-0.46	-1.46	+4.54	-1.26	-3.16	+1.44	+0.14	-1.89

Mean of the means on individual insulators = 68.46 kV.

(From a Paper by B. L. Goodlet "Testing of Porcelain Insulators.")

The properties of the various metals used are not given, as they can easily be obtained elsewhere.

TESTING PORCELAIN INSULATORS

The generally accepted tests for insulators are fully explained in the various National Specifications (British—B.S.S. No. 137, American—A.I.E.E. No. 41). This information is not repeated, but difficulties and modifications that will be encountered are considered.

Variations in Test Results and Some of their Causes

PHYSICAL DIFFERENCES IN INSULATORS. From what has been said on the manufacture of porcelain, it will be realized that insulators made to the same drawing will not be strictly identical. The variations, though usually small, have an effect on the insulator's characteristics.

A slight reduction in a shed diameter due to settling during firing will affect the spark-over figures. A warp in a shed or a local increase in glaze thickness may influence the water distribution under rain, and so on. This fact is clearly demonstrated by the tests recorded in the tables* given on p. 83, which give the dry and wet spark-over of ten different insulators of the same design.

VARIATION IN TEST CONDITIONS. Apart from the varying test values obtained on insulators of the same design, the figures obtained on the same unit tested at different times vary. The causes of these disparities can be divided into four groups—

1. Atmospheric change.
2. Difference in test set up.
3. Tests taken at different testing laboratories.
4. Unaccountable.

Variation No. 1 is recognized in most specifications. In B.S.S. No. 137 the effects of temperature and air density are acknowledged, and a graph is given to enable voltage readings to be adjusted. Variations due to humidity are also mentioned, but no method for correcting voltage readings is given. A standard condition at which guarantee figures apply is stated to be: Temperature 25° C.; barometric pressure 760 mm.; humidity 80 per cent. The influence of humidity and temperature on spark-over values on clean insulators is shown in Fig.

* Goodlet, "The Testing of Porcelain Insulators," *I.E.E.*, 1929.

53. It will be observed that the effect on each insulator tested differs; it is therefore impossible to obtain a universal correction factor.

The A.I.E.E. Specification No. 41 specifies a standard test condition, a vapour pressure of 0.6085 in. (15.45 mm.) of

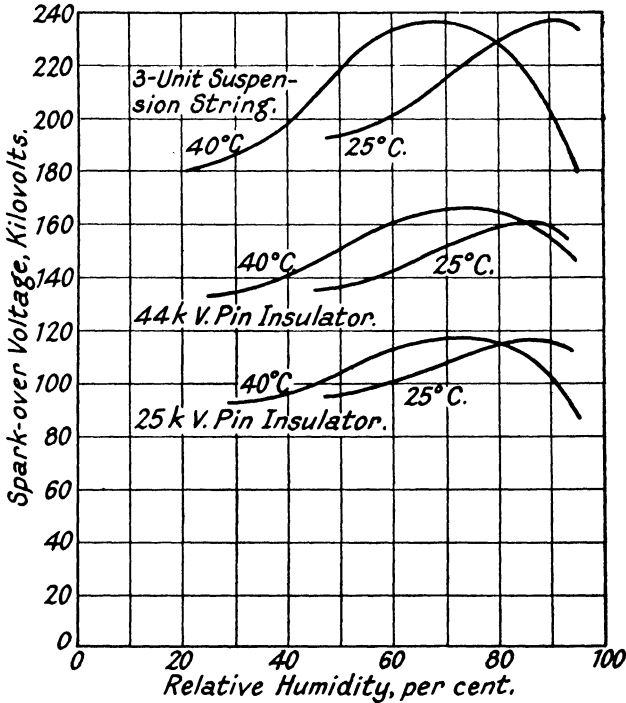

FIG. 53. THE INFLUENCE OF HUMIDITY AND TEMPERATURE ON SPARK-OVER VALUES
(Goodlet and Milford)

mercury. This is equivalent to a relative humidity of 65 per cent at 77° F. (25° C.) and a barometric pressure of 30 in. (762 mm.).

No graph is given for temperature or air density correction, but a method of deducing humidity variations is suggested as a temporary measure pending a more satisfactory solution (section 41—601). Three sets of tests are taken on each type of insulator at different humidities, at least one test being made at a higher and one at a lower humidity than standard. The

spark-over at standard humidity is then graphically interpolated along a smooth curve drawn through the three points determined by the tests with spark-over voltage and vapour pressure as co-ordinates.

A tolerance is also given which it is stated is to provide for testing variables which are difficult to control (41—104). "The spark-over voltages of a pin-insulator design shall be considered as checked, if the average of the dry spark-over voltages of three insulators shall be within 5 per cent and the average of the wet spark-over voltages of three insulators shall be within 10 per cent of the corresponding assigned voltage."

The British Specification (paragraphs 11 and 12) is not so accommodating. "The voltage at which spark-over occurs shall be not less than that shown in columns 2 and 3 of Table I."

Due to this lack of tolerance in the British Specification a designer will need a higher factor of safety to ensure compliance than would be necessary were he working to the American Specification.

The difficulty of reproducing spark-over tests is clearly illustrated by Goodlet.

"A certain pin-type insulator was mounted in the laboratory and its dry spark-over voltage observed at intervals over a long period, all controllable conditions being held as nearly constant as possible. On the occasion of each test the first few figures were discarded, the mean being derived from ten subsequent observations.

"The average deviation of the mean spark-over voltage on any one occasion from the mean of all the figures taken was ± 2.4 per cent while the maximum deviations were as much as $+ 8$ per cent and $- 4.2$ per cent."

Variation No. 2. The set-up of insulators for test is a further fruitful cause of variation. An insulator tested alone by bringing a testing wire direct to the top cap will usually give different results from those obtained with the same unit assembled in a switch or other piece of apparatus. Variation will also occur with the shape and size of the apparatus carried. The effect on the dry spark-over is usually caused by the resulting change in the field form. In some cases the distance from live metal to earth is reduced.

Wet spark-over may be influenced by uneven water distribution. A piece of apparatus may be of such a shape that

water is collected by it and discharged in a stream at one spot.

Variation No. 3. To obtain varying values on the same insulators when tested at different testing plants is disconcerting to all parties concerned, particularly when the tests are to prove contract guarantees. Frequently such discrepancies are found to be due to an incomplete history of test conditions. As an example, the 44 kV. pin-type insulator in Fig. 53 can be taken. If No. 1 Plant tested at 40° C. with 75 per cent humidity, the dry spark-over would be approximately 166 kV. No. 2 Plant may have tested at 40° C. but with 30 per cent humidity, thereby obtaining a dry spark-over of approximately 136 kV.

The necessity for recording complete test data is obvious, but in many cases it is neglected. In certain cases the discrepancies are due to differences in the test plants concerned. No. 1 Plant may consist of carefully designed and checked machines and transformers with an accurate method of voltage indication. No. 2 Plant may default in some of these essentials.

B.S.S. No. 137 (1930), Section V, page 9, attempts to stabilize testing methods but gives considerable latitude, presumably to avoid the re-equipping of existing laboratories to comply to one standard.

No matter what methods of obtaining and measuring the test voltages are used, a satisfactory equipment should comply with the following general conditions—

1. The actual alternating voltage used for testing must be as nearly as practicably possible of true sine-wave form.
2. The low tension voltage supplying the testing transformer must not be capable of varying except by methods under the complete control of the testing engineer. As an example, a supply which in addition to feeding the testing transformer supplied power to a heavy intermittent load, thereby causing voltage variation, would be unsuitable.
3. The rating of the complete plant must be such that it remains stable up to the largest capacity load likely to be imposed.
4. Voltmeter readings must check up with spark-gap settings throughout the entire range and be unaffected by the capacitance of the apparatus under test.
5. Any method of varying the test voltage which at intervals momentarily disconnects the apparatus under test, must not be used. Such methods usually cause voltage surges which

are not indicated on the voltmeter, but which may cause premature spark-over.

Puncture Tests. As already stated, insulators are designed to spark-over at a voltage considerably lower than their puncture value when tested in air at commercial frequency. Surface spark-over must therefore be eliminated if the unit is to be punctured.

The usual method is to immerse the insulator in oil. This method introduces variations that are entirely independent of the insulator. The presence of the oil along the surface of the insulator seldom, if ever, entirely eliminates brush discharge right up to the value at which puncture takes place. The voltage at which discharge commences will vary with the dielectric strength of the oil. These discharges which commence at a much higher voltage than those in air are of an entirely different type to the latter. Once started they develop far quicker, are more concentrated, and of greater intensity. The streamers remain at the surface of the insulator burning a path for themselves in the glaze. Once discharge has commenced, breakdown usually follows, even when the voltage is not raised above the discharge value. Further, owing to the dissimilarity between the discharges in oil and air, the modifications to the dielectric field caused thereby bear no relation to one another. Fortunately for the user all this tends to give a lower figure than the true puncture value.

Variations can also be caused by the size, shape and material of the testing tank used: too small a tank influences the field distribution, whether it be made of metal or insulation. The A.I.E.E. again recognize the difficulty (41—203) by allowing an average deviation of 10 per cent. B.S.S. No. 137, Clause 16, does not allow a tolerance but states that the voltage need not be taken above the guaranteed puncture value.

Mechanical Tests. The tests specified in the various National Specifications refer to pin-type insulators for transmission line service, and the mechanical tests are arranged accordingly. B.S.S. No. 137, for instance, gives one test only, a bending load of $2\frac{1}{2}$ times the specified working load applied at the top of the unit at right angles to the axis.

The varying mechanical duties required of switchgear insulators make it necessary to broaden the scope of mechanical tests, and torsional and tensional type tests are necessary. In certain cases a vibration test is specified, the rate of vibration

being of the order of 150 per min. During the vibration period, which is usually approximately 8 hr., the insulator carries its normal working load. This test is to demonstrate an insulator's ability to withstand vibration caused by winds.

Porosity Test. This test, which was very necessary a few years ago, could now be dispensed with as a type test on finished insulator units purchased from makers of repute. The improvements made in electrical porcelain manufacture and the factory tests taken make it practically impossible for a porous porcelain to be built up into an insulator unit. Its deletion from specifications might, however, encourage unscrupulous makers to supply an inferior product.

Temperature Cycle Test. This test, also known as the "Inherent Stress Test," was brought into being to demonstrate the capability of an insulator to withstand the variations of temperature met with in service. It is an intensified form of these conditions. The nearest natural approach in severity is a sleet storm occurring after a period of hot sunshine. This test, apart from stressing the porcelain, expands and contracts the metal fittings and the cement used for their assembly.

Insulators that have withstood this test satisfactorily have been known to fail in service through porcelain cracks caused by expansion of metalwork. The knowledge of this fact has resulted in a demand by some engineers for an increased temperature range. This practice is of doubtful value. A temperature variation from 7° C. to 70° C. is virtually impossible in service, therefore failure occurs at a temperature range below that at which tests were made. Thus it must follow that some change has taken place between the time of testing and the failure. An increase in the test temperature range cannot ensure that detrimental changes in structure will not occur.

High Frequency and Impulse Tests. These tests have not as yet been adopted as standard procedure in National Specifications, although mention of them is made. Again, taking the British and American Specifications as examples, B.S.S. No. 137, 1930, Appendix III, gives a quantity of useful information in a condensed form, and states "It is considered inadvisable to incorporate any test of this nature in a standard specification until further information is available." The A.I.E.E. Specification gives an optional h.f. test for suspension insulators only.

The advantages of such tests are recognized by most organizations, and many testing laboratories are equipped for making

them. The general principles involved are therefore worthy of short consideration. Inasmuch as the impulse test represents conditions actually obtaining in practice, its incorporation in the standard specifications at some not distant date is almost certain.

For every dielectric there is a limiting value of the steady field intensity, beyond which breakdown of the dielectric will occur. This intensity, as already stated, is measured by the number of lines of force per unit area. Breakdown of a dielectric does not occur instantaneously, since such a breakdown necessitates the expenditure of energy and this involves time. Thus, when the voltage is slowly increased until the breakdown intensity of field is obtained, a spark does not pass immediately. The energy of discharge will be of the form

$$E = \frac{1}{2} DdIt$$

where D equals the field intensity, d the distance apart of electrodes, I the current, and t the time for spark to pass. This equation will have a minimum value for each dielectric; thus, with a given value of D and d , there will be a minimum value of time t before the spark will pass. This is the time-lag for the particular dielectric at the given voltage. To consider air, which is the most common dielectric subject to spark discharge, the reason for the time-lag is that before a spark can develop the free ions and electrons in the surrounding medium have to be accelerated by the electric field until they have produced further ions by collision, which in their turn must also produce ions. During the time that ions are being produced by collision processes, re-combination of ions is also proceeding, and the final development of the complete discharge or spark between the electrodes signifies that the processes of production of ions have overtaken those of re-combination of ions. This takes time, and the value of this time-lag depends on many conditions. Primarily it depends on the presence in the air of some ions initially. If two electrodes, say plates, are submitted to a difference of electrical pressure, and if the intervening air were perfectly dry and free from all trace of ionization, no spark would pass until the potential was raised to a sufficiently high value so that the potential barrier of the negative electrode was overcome and electrons were thus emitted to start the ionization of the air preparatory to the full development of the spark. Such a condition in ordinary practice never exists.

There are always many free electrons or ions present in the atmosphere. Daylight alone acting on the electrodes will produce electrons, while the action of ultra-violet rays is very intense in this respect. Above all, the radio-active matter contained in the soil and air is sufficient to maintain a considerable state of ionization in the air. Given then that electrons are present, the voltage between the plates will set them in motion. From the collisions and resulting ions, the number of charged particles in motion increases very rapidly, finally resulting in a discharge of spark dimensions.

In any high voltage test for spark-over using alternating pressures, the whirring sound that is heard to increase gradually until it becomes the crack of the spark, results from the partial breakdown of the air at each succeeding half cycle until at one half cycle the breakdown path of the discharge extends from one electrode to the other, the ultimate discharge being reached in so short a space of time that the sound becomes a crack.

The time-lag of breakdown is one of the most important features in impulse spark-over of insulators and of solid and liquid dielectrics. It is present in all kinds of dielectrics. Its value is subject to the laws of chance, varying between wide limits for a given gap and for different dielectrics. In the case of a gas it is affected by pressure, temperature, composition, history, etc., all of which should be quite apparent. The shape of the conductor affects the lag in so far as the smaller the conductor area, or projected area, perpendicular to the direction of the field, the smaller the volume of gas intervening, and therefore the smaller the number of free electrons and ions available to commence the ionization of the path. The extreme case of this is the point electrode, and with points a time lag of from three to four times that for large surfaces is experienced. For shaped surfaces between the point and the sphere, rather shorter time-lags occur, whilst for spheres at spacings less than three-quarters of their diameters, the time-lags are extremely small; of the order of $\frac{1}{10} \mu$ sec. The time-lag referred to so far is that corresponding to the minimum voltage which will cause a spark to pass between the electrodes. When voltage is applied at a commercial frequency of say 50 cycles per sec., the spark-over value must be maintained for a certain minimum time to accommodate the above lags, if spark-over is to occur. This is indicated in Fig. 54, where V_1 is the minimum spark-over voltage and t_1 the time for which the voltage V_1 is maintained

during a half cycle. At the frequency stated, the value of t_1 will necessarily be less than 0.01 sec., and will also be affected by the shape of the voltage wave. For higher frequencies with the same peak values, the time of duration of the voltage V_1 will be less per half cycle than t_1 . It will be, say, t_2 . Therefore, other things being the same, there will be a value of high frequency for which the value of t_2 will be less than the time-lag of the dielectric as above defined, and spark-over will not occur at that voltage V_1 . In order to obtain spark-over at this higher

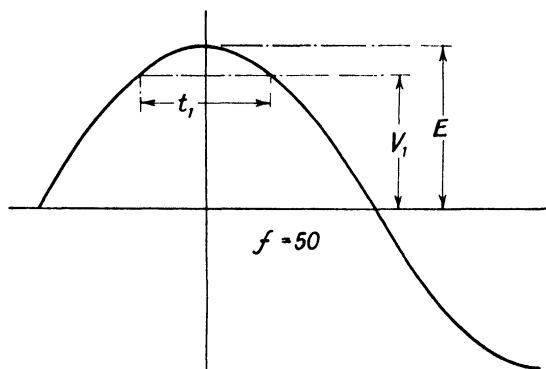

FIG. 54. 50-CYCLE SINUSOIDAL VOLTAGE WAVE
Showing duration of minimum spark-over value of V_1 .

frequency, it is necessary for the value of the peak voltage to increase above the nominal value V_1 , and thus compensate for the decrease in the time value t_2 such that the energy expression $E = \frac{1}{2} D d I t$ remains unchanged. Suppose, for example, a dielectric to have a time-lag of one microsecond, and for given gap length, a nominal minimum spark-over value of 100 000 volts d.c. Then, with a 50 cycle sinusoidal voltage wave, the minimum peak value to effect spark-over would be very slightly more than 100 000 volts. This is because the time to reach the peak value from zero is 5×10^{-3} sec., and the time to reach the value 100 000 volts which is to endure for a minimum of 10^{-6} sec., is $5 \times 10^{-3} - 5 \times 10^{-7} = 4.999 \times 10^{-3}$ sec. This corresponds to an angular value of 0.009° from the peak value; therefore

$$100\,000 = E \sin 89.99^\circ$$

From which

$$E \simeq 100\,000 \text{ V. (See Fig. 55.)}$$

In the case of a high frequency of say 200 000 cycles per sec. (see Fig. 56), the time from zero to peak is 1.25×10^{-6} sec. The angular displacement of the 100 000 V. value from the peak value

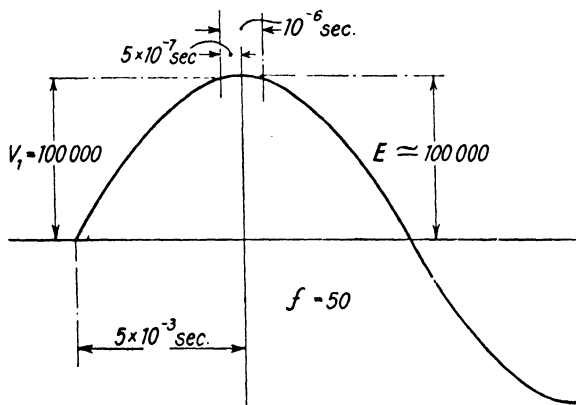

FIG. 55. 50-CYCLE VOLTAGE WAVE
Showing that a 100 kV., 1μ sec. gap breaks down at practically peak voltage on the wave.

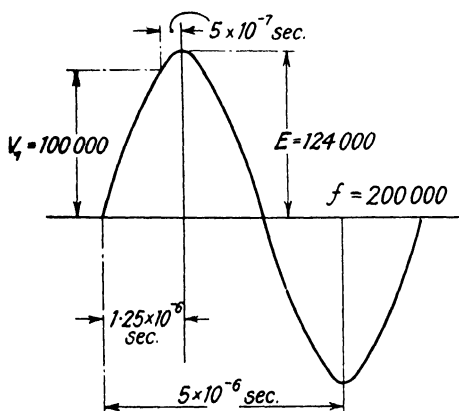

FIG. 56. 200 000-CYCLE VOLTAGE WAVE
Showing that a 100 kV. 1μ sec. gap requires a peak value of approximately 124 kV. for breakdown.

is $\frac{5 \times 10^{-7} \times 90}{1.25 \times 10^{-6}} = 36^\circ$. Therefore, $E = \frac{100\ 000}{\sin 36^\circ} = 124\ 000$ V.

In the case of an impulse or surge which, suppose, reaches its peak value in half a microsecond and has a tail of the form

$$V = Ee^{-t/K}$$

where E is the peak value and K a circuit constant; to find the value which E must reach to effect spark-over, suppose K equals 1.5×10^{-6} . Then,

$$\begin{aligned}
 100\,000 &= Ee^{-(10^{-6}/1.5 \times 10^{-6})} \\
 \text{or } E &= 100\,000 \times 2.72^{.67} \\
 &= 100\,000 \times 1.95 \\
 &= 195\,000 \text{ V. (See Fig. 57.)}
 \end{aligned}$$

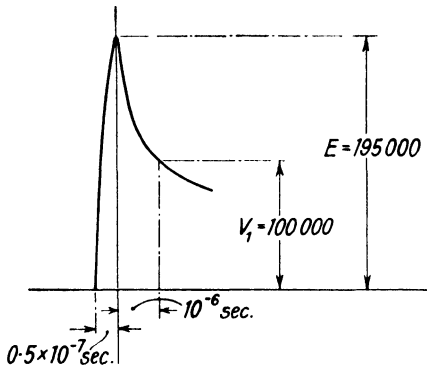

FIG. 57. IMPULSE VOLTAGE WAVE
Showing peak value required for a 100 kV., 1 μ sec. gap.

Thus, with a given dielectric and given gap conditions, the spark-over values are 100 000, 124 000 and 195 000 volts for commercial frequency, high frequency and surge or impulse frequency respectively.

The above is the generally accepted theory for the variation of spark-over values at different frequencies, etc., but it must be understood that it is not strictly correct numerically, and is only intended to indicate the way the time-lag of breakdowns affects the spark-over figure.

If V_1 is the voltage to break down a gap at a given commercial frequency, and V_2 the voltage to break down the same gap at impulse pressure, the ratio of V_1/V_2 has been designated by F. W. Peek, Jr., as the impulse ratio of the gap concerned. With spheres this ratio is of the order of unity, and with points it is from 1.5 to 2. For gaps of a form intermediate between the sphere and point it has a value between 1 and 2. For example, the impulse ratio of a pin and cap type insulator is

approximately 1.3. A table of impulse ratios cannot be given because they vary so much with different designs of apparatus.

The way in which the time-lag varies with the applied voltage may not be the same for the air surrounding an insulator as for the material of the insulator itself, therefore it will be apparent that an insulator which sparks over below its puncture value when tested at 50 periods will not necessarily behave in the same manner on high frequency or impulse. The high spark-over values obtained may be sufficient to cause puncture. Such tests would therefore seem essential when trying out new designs.

High Frequency Testing. It is established that undamped

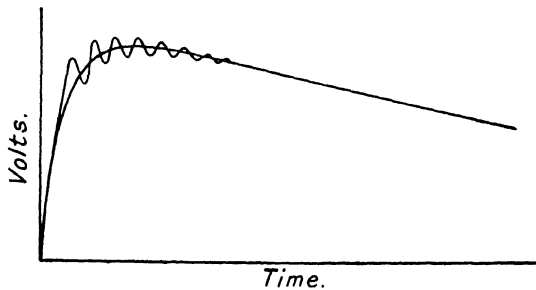

FIG. 58. SHOWING H.F. OSCILLATIONS ON AN IMPULSE VOLTAGE WAVE

high frequency oscillations do not occur in power systems. Various frequencies for damped oscillations are specified by different authorities. As an instance, A.I.E.E. mention both 200 000 and 100 000. Goodlet suggests 100 000 as a standard, stating that from his knowledge the highest frequency to cause serious trouble was 80 000; also that the variation in spark-over between 66 000 and 587 000 cycles was small.

Impulse Testing. The last few years have seen a distinct advance in impulse testing technique. The principal factor contributing to this improvement is the development of the cathode ray oscillograph. This instrument enables wave shapes to be accurately recorded, whereas previously their form was determined by calculation. It thus discloses undesirable features in an impulse generator wave-form when such are present. When used for insulator testing, the point on the wave at which spark-over occurs is recorded. Fig. 58 illustrates an example shape of an impulse wave when h.f.

oscillations are present. Prior to the introduction of the cathode ray oscillograph the oscillations shown at the peak were suspected, but their nature was unknown. It was therefore difficult to eliminate them. Their presence, however, had a definite influence upon the values obtained by the measuring sphere gap, as the voltage measured was that of the highest peak value of these oscillations. The cathode ray oscillograph records this phenomenon, and this enables the required correction to be made.

Standardization has not yet been possible, as research on this matter is still proceeding. Until standard specifications can be issued, misunderstandings will be unavoidable, as wave shape terminology and definitions will vary with different engineers. Perhaps the more important point is that results obtained at different testing laboratories will be difficult to compare. To illustrate this point, one example is given. The impulse ratio of a particular insulator will seem to have a higher value when tested with a voltage wave having high frequency oscillations present than when tested with a smooth or "corrected" wave.

In order to help in the better understanding of impulse testing data, the following designations are given—

Designation of Wave-form. The present method of designating impulse waves is to specify them in the form of a fraction. The equivalent of the numerator denotes the steepness of the wave front, or the time from the foot to the peak of the wave, and that of the denominator the time from the foot of the wave to the instant when the tail has dropped to half the value between peak and zero. Thus suppose a wave rises from zero to a peak of say 500 kV. in 1μ sec., and falls from peak to 250 kV. in 19μ sec., then this would be specified as a $\frac{1}{19}$ wave.

Positive and Negative Values. When the electrodes are dissimilar, the spark-over value will vary for a positive and a negative wave. This is because of the different field formations at the two electrodes having different effects on the time lag for the commencement of the spark. To take an extreme example the better to emphasize the fact, in a point-to-plate gap, when the point is of negative polarity, the development of the spark will not be so rapid as when the point is of positive polarity.

Maximum and Minimum Impulse Spark-over Values. The spark-over value of an insulator may be varied between definite limits known as *maximum* and *minimum values*.

MINIMUM SPARK-OVER VALUE. This figure may be obtained by connecting the insulator under test in parallel with a measuring sphere gap. The voltage and gap are then adjusted so that during a predetermined number of voltage applications spark-over occurs an equal number of times over the insulator and the measuring gap. Oscillographic records taken on such

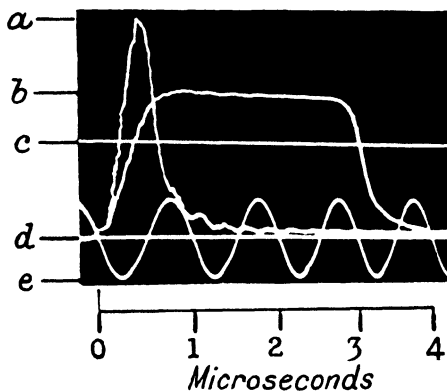

FIG. 59. CATHODE RAY OSCILLOGRAPH OF MINIMUM AND MAXIMUM IMPULSE SPARK-OVER ON A PARTICULAR INSULATOR
(Metropolitan-Vickers, Research Dept.)

Wave Front -- 1 μ sec.

Wave Tail -- 50 μ sec.

(a) Maximum impulse spark-over.

(d) Zero line.

(b) Minimum impulse spark-over.

(e) Timing oscillation.

(c) Calibrating voltage line.

Wave length = 300 metres.

Oscillogram 301/5

tests have shown that spark-over occurs at a point along the tail of the wave.

MAXIMUM SPARK-OVER VALUE. If the measuring gap now be increased and the applied voltage raised, it will be found that the spark-over figures obtained will increase also, until a value is reached when a further increase in voltage will not produce a higher spark-over value on the insulator. The reason is that spark-over is now occurring on the front of the wave. The latter is arrested in its upward trend by the insulator sparking over, and the amplitude it would have otherwise attained can have no influence on the spark-over value. Fig. 59 shows the minimum and maximum impulse spark-over of a particular insulator recorded on one and the same oscillogram.

The ratio between maximum and minimum spark-overs

varies with wave form, and the insulator under test. With a 0.5/1 wave both values would be virtually the same. With a long tail wave the ratio will become appreciable. The minimum spark-over is influenced primarily by the length of tail, whilst the maximum figure is controlled by the rate of rise of voltage at the wave front. When the type of spark-over is not stated, it is usual to assume that minimum figures at positive values are required.

The author's remarks on high frequency and impulse voltages are necessarily brief, since the problem is one of great complexity and cannot be dealt with in anything like its entirety in this book. Reference should be made to the works of Allibone, etc. Finally, it should be noted that spark-over depends upon the gap, temperature, atmospheric pressure, humidity, frequency, wave form, light, and other sources of ionization. It is essential that records of tests should be complete in every detail, otherwise comparison is impossible.

BIBLIOGRAPHY

- A.I.E.E. Specification No. 41.
 T. E. Allibone, discussion on Goodlet's paper, *J.I.E.E.*, 1933.
 B.S.S. No. 1371
 F. P. Burch and R. V. Whelpton, "Cathode Ray Oscillograph," *J.I.E.E.*, 1932.
 G. R. Falkner Nuttall, *World Power*, June, 1930.
 S. W. Farnsworth, *A.I.E.E. Trans.*, 1913.
 C. L. Fortescue, *A.I.E.E. Trans.*, 1913.
 E. H. Fritz, *Elec. World*, Aug., 1932.
 B. L. Goodlet, "Electromagnetic Phenomena in High Voltage Testing Equipment," *J.I.E.E.*, 1934.
 B. L. Goodlet, "Testing of Porcelain Insulators," *J.I.E.E.*, 1929.
 B. L. Goodlet and J. B. Mitford, "International Conference on Large Electric Systems, Paris, 1929."
 A. Mathias, *Elektrizitätswirtschaft*, Nov., 1927.
 S. M. Murray-Jones, *Elec. World*, Dec., 1930.
 F. W. Peek, Jr., *Dielectric Phenomena*.
 P. J. Ryle, *J.I.E.E.*, July, 1931.
 Sir J. J. Thomson and G. P. Thomson, *Conduction of Electricity through Gases*.
 R. C. J. Wood, *J.A.I.E.E.*, Dec., 1929.

CHAPTER V

AIR-BREAK SWITCHES FOR LOAD BREAKING AND ISOLATING PURPOSES

THERE exists a certain amount of confusion as to the precise difference between a switch used for isolating purposes and one capable of load breaking.

The two main factors contributing to this uncertainty are—

1. Most makers use the same general design of switch for both purposes.

2. Switches which are only capable of breaking the magnetizing current of a transformer are often designated as "Air-Break Switches."

To clarify the situation a short specification is given of each type.

Isolating Switches. The operation of an isolator must be carried out after the circuit has been broken. Interlocks are often fitted to ensure the meeting of this condition.

Single phase switches operated by a separate insulated operating pole, or multiphase units connected together by a common mechanism extending to ground level, may be used. The phase and pole centres are dictated by flash-over values.

Light Load-Breaking Switches. The usual duty of this type of switch is the breaking of transformer no-load magnetizing currents. Load currents of a few amperes can as a rule be successfully broken under normal weather conditions, provided the power factor be good. Such switches are in use for voltages up to 220 kV. In many instances an isolating switch mounted at slightly greater phase centres and fitted with arcing horns is used.

Load-Breaking Switches. Under this heading are included switches capable of breaking normal load currents, or rupturing the charging currents of transmission lines. Their use makes possible the electrification of districts where capital cost must of necessity be limited. The clearances between phases and poles are determined by the size and shape of the arc formed during opening rather than by arc-over requirements.

Pole Operated Isolating Switch. Fig. 60. The limit in the application of this type of switch is set by the difficulty experienced in manipulating the operating pole. When the switch

has to be mounted at, say, 20 ft. above ground, the length of the pole becomes unwieldy. The difficulty is aggravated when there is a wind blowing and also if access is impeded by floor mounted apparatus. Operation at night is intricate and a check to ensure that all phases have been operated is necessary.

The one excuse for the design is its low cost.



FIG. 60. TYPICAL 37 kV. HORIZONTAL BLADE
ISOLATING SWITCH

(British Thomson-Houston Co., Ltd.)

The essential features are—

1. The ring or catch attached to the blade to accommodate the pole hook should be at least 4 in. in diameter in order to make engagement possible when high mountings are used.
2. The blade and jaw should be designed for strength and robustness, since they may be subject to considerable side thrust due to the operator not being able to get a straight pull.
3. Vertical mounting, Fig. 11, should be avoided above 66 kV., as bending moment imparted to the insulators during the opening pull is too great for the standard designs of post insulators. This pull must be computed on the value required to overcome stiffness in the break jaw, due to ice or dirt.

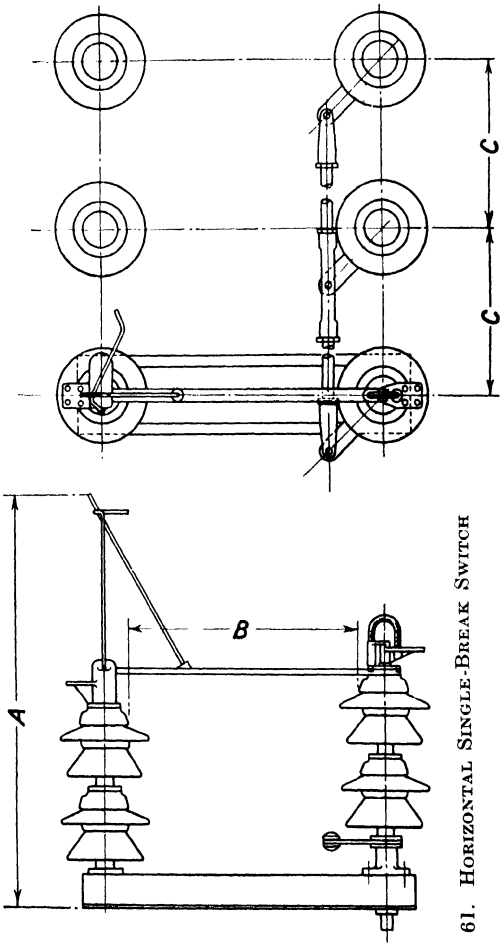

FIG. 61. HORIZONTAL SINGLE-BREAK SWITCH

Voltage Rating	A		B		C	
	For Air-Break Switches	For Isolating Switches	For Air-Break Switches	For Isolating Switches	For Air-Break Switches	For Isolating Switches
11 000	ft. in. 2 9	ft. in. 1 2	ft. in. 1 0*	ft. in. 1 0*	ft. in. 3 6	ft. in. 2 9
22 000	3 2½	1 5	1 5½	1 0*	4 0	3 1
33 000	3 9	1 6	2 0	1 2	5 0	4 2
44 000	4 6½	1 10	2 6½	1 7	6 0	4 11
66 000	5 5½	2 0½	3 5½	2 1	8 0	6 0

* These dimensions are greater than necessary from electrical considerations; the ruling factor being bird clearances.

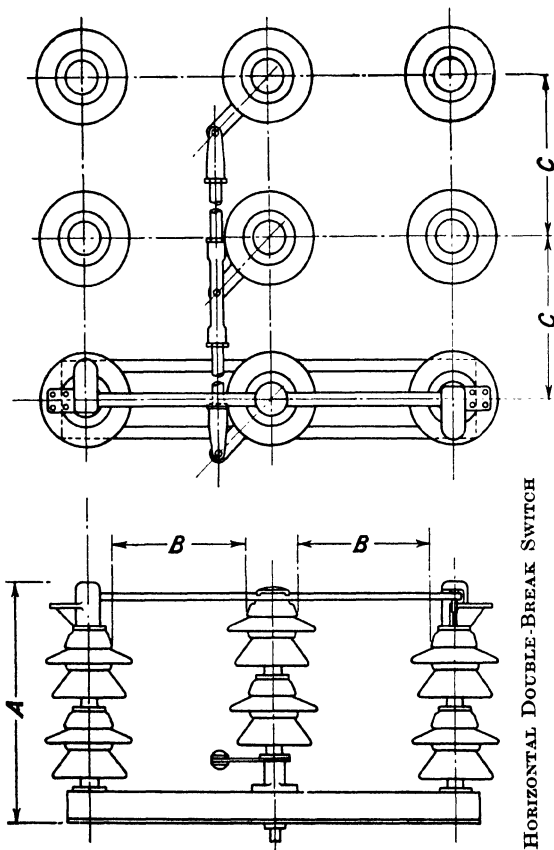

FIG. 62. HORIZONTAL DOUBLE-BREAK SWITCH

Voltage Rating	A	B	C
33 000	ft. in. 1 6	ft. in. 7 $\frac{1}{2}$	ft. in. 5 11
44 000	1 10	9 $\frac{1}{2}$	2 11
66 000	2 0 $\frac{1}{2}$	1 0 $\frac{1}{2}$	3 2
88 000	3 5 $\frac{1}{2}$	1 5	4 2
110 000	5 1 $\frac{1}{2}$	2 3	7 10
132 000	7 11 $\frac{1}{2}$	2 8 $\frac{1}{2}$	7 16
165 000	9 3	3 4 $\frac{1}{2}$	8 11
220 000	9 6 $\frac{1}{2}$	5 4	12 2

Gang-operated Switches. Although detail designs vary considerably, practically all switches of this type fall under one of three headings—

Horizontal Break ;

Vertical Break ;

Carriage Type.

HORIZONTAL BREAK. This type is perhaps the most popular. Up to 33 kV. it has a close rival in the vertical break "Rocker" switch, but above this voltage it is used by most manufacturers. A single break arrangement is usually adopted up

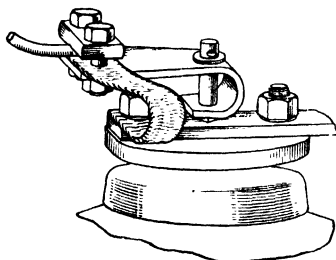

FIG. 63. CHEAP TYPE OF SWIVEL TERMINAL

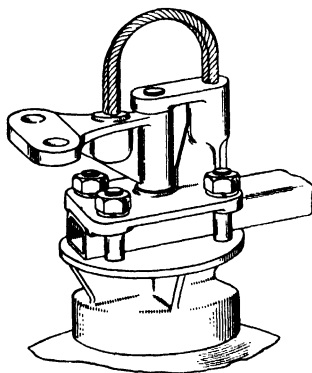

FIG. 64. SWIVEL TERMINAL

to 66 kV., Fig. 61, and a double break above this voltage, Fig. 62.

In both cases operation is carried out by rotating the insulator to which the blade is attached.

The only special detail occurs in the single break type. One of the leads to the switch has to be taken to the revolving insulator. This necessitates a swivel terminal. Two examples are shown in Figs. 63 and 64.

The horizontal break makes possible a simple design using a small number of robust parts. The single break type has but two insulators per phase. As the moving portion is revolved and not lifted, operation is comparatively easy.

The disadvantage of this design is that phase centre dimensions are greater than for the vertical break types when used as isolating switches. This applies particularly to single break units. When used for load breaking the phase centres necessary

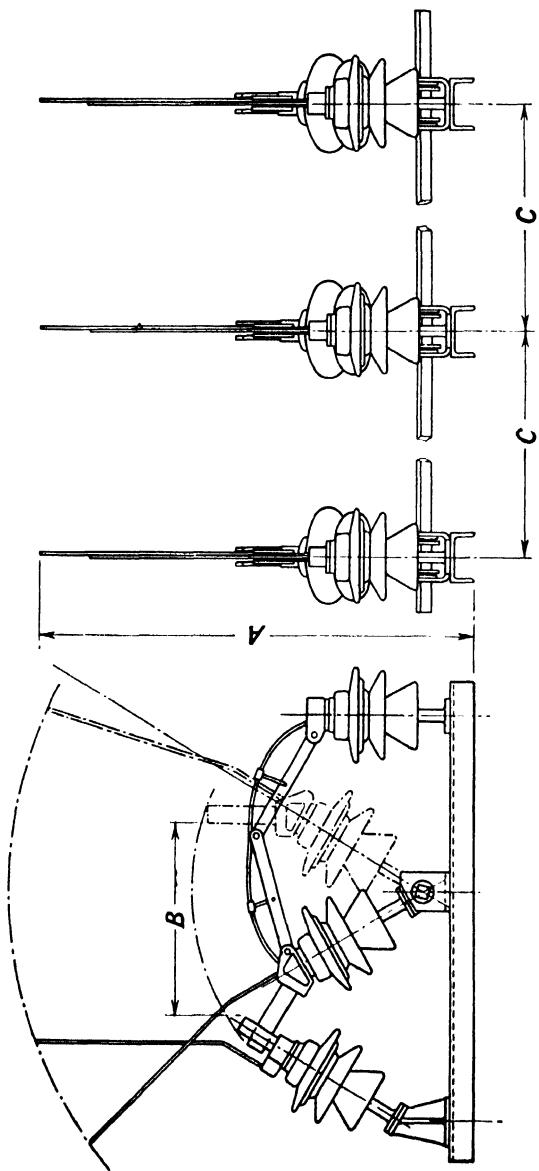

FIG. 65. ROCKER TYPE SWITCH

Voltage Rating	A		B		C	
	For Air-Break Switches	For Isolating Switches	For Air-Break Switches	For Isolating Switches	For Air-Break Switches	For Isolating Switches
11 000	ft. in.	ft. in.	ft. in.	ft. in.	ft. in.	ft. in.
22 000	4 8	1 7	1 0	9	3 6	1 6
33 000	4 11	1 11	1 6	1 0	4 0	2 0
	5 1	2 1	2 0	1 3	5 0	2 6

are the same for all types of switch. This will be referred to later.

VERTICAL BREAK. This type of switch can be again subdivided into two main groups—Rocker Type and Revolving Insulator Type—the former being the more popular.

Rocker Type (Fig. 65). This design lends itself to sound economical construction up to 33 kV. Above this voltage it is very difficult to balance the moving portion, hence undue stresses are imposed on the moving insulator and operation is

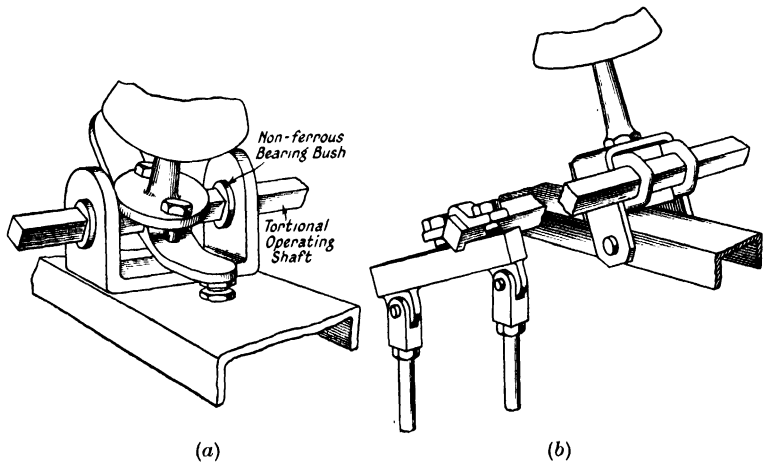

FIG. 66. ROCKER TYPE SWITCH OPERATION

rendered difficult. This objection has been successfully overcome in some cases by counter-balancing or by the use of buffers. This switch shares with all other vertical break types the advantage that it can be mounted at minimum phase centres when used as an isolator or light load-breaking switch. The special design features are the electrical connection between the swinging and stationary insulator, Fig. 65, and the method of ganging the phases. Fig. 66 (a) and (b) shows two methods; in 66 (a) the interconnecting rod is in torsion; in 66 (b) arrangement the torsion stress is relieved.

Revolving Insulator Type. The operating mechanism for this type is similar to the horizontal break type. The difference is that instead of the blade being solidly coupled to the top of the revolving insulator, a mechanism transferring the horizontal swing to a vertical operation is necessary. Many ingenious

designs are in existence which accomplish this change in motion. Figs. 67 and 68 show two typical cases. The complete cost of this type is greater than that of either the horizontal break or

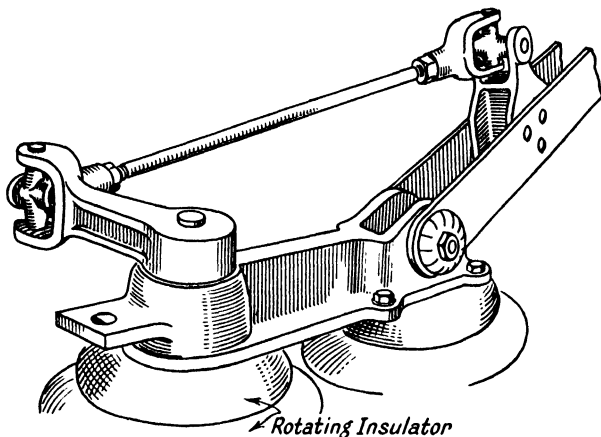

FIG. 67. VERTICAL-BREAK ROTATING INSULATOR AIR-BREAK SWITCH OPERATION

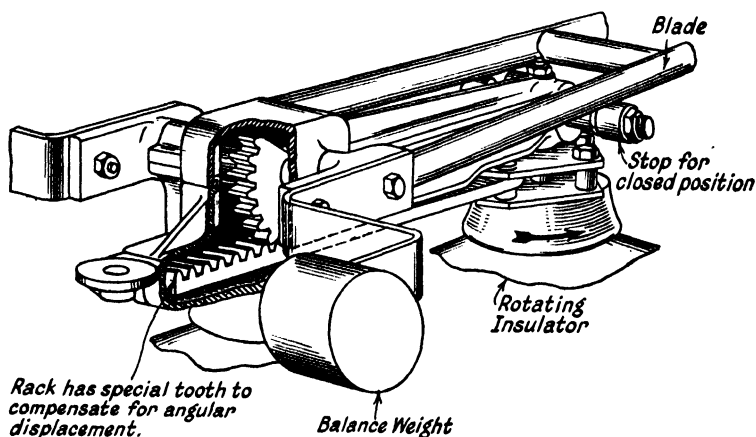

FIG. 68. VERTICAL-BREAK MECHANISM FOR AIR-BREAK SWITCH FOR 115 kV AND ABOVE

rocker type switches. For this reason its field is limited. Its main application is for load-breaking switches for 66 kV. and above.

CARRIAGE TYPE. The construction of this switch is such that

the moving contact or blade complete with its insulator, is mounted upon a carriage which is propelled by gearing, chains or other means. The construction is inherently costly and can only be considered for 110 kV. and above. It is only used in special cases where its construction suits a particular station

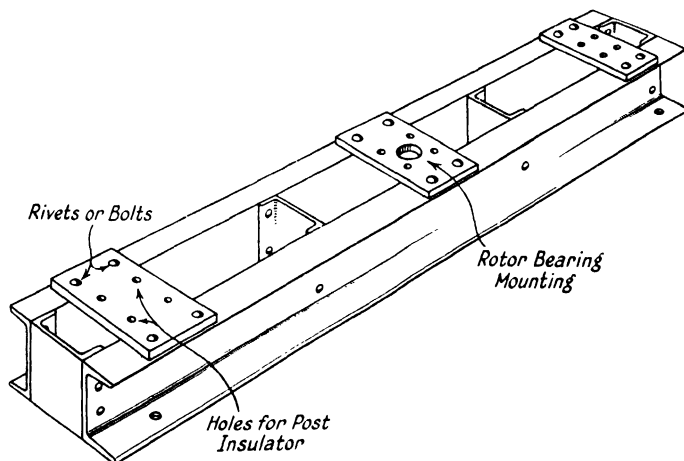

FIG. 69. BUILT-UP TYPE OF ISOLATING SWITCH BASE

lay-out, and therefore the greater cost can be offset against saving in structures, etc.

GENERAL DETAILS APPLICABLE TO ALL TYPES OF SWITCHES

Bases. For voltages up to 66 kV. a channel section base is generally used. It may be rolled steel section or folded from sheet, the latter being cheaper for the smaller sizes. At 88 kV. and above the increased pole centres and weight demand a more rigid construction. Fig. 69 shows a popular built-up type. The advent of electrical welding and metal folding has resulted in several new types of base being produced. Figs. 70 and 71 show two examples. It is always advisable to design isolator bases slightly flexible, so as to minimize the shock imparted to the insulators during operation.

Rotating Insulator Bearings. The type shown in Fig. 72 is satisfactory provided the weight of the insulator and blade does not exceed 100 lb. The blade length should not be longer

than 54 in. Above these limits it is necessary to fit either ball or roller races. (Fig. 73.)

The bearing proper should in all cases be either babbitt lined

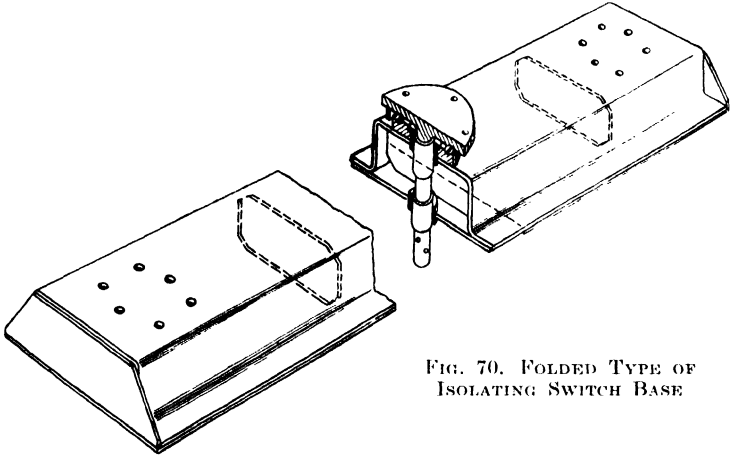

FIG. 70. FOLDED TYPE OF ISOLATING SWITCH BASE

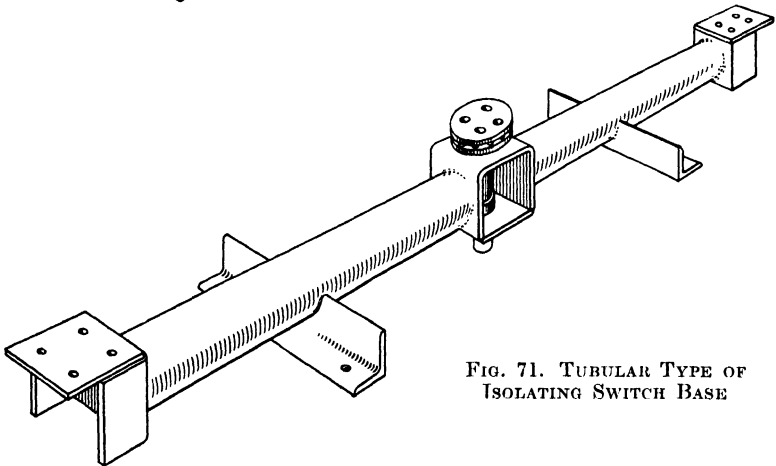

FIG. 71. TUBULAR TYPE OF ISOLATING SWITCH BASE

or bushed with a non-ferrous metal. In Fig. 70 the bearing forms an integral part of the base.

Break-jaw Contacts. The design of contacts differs with almost every make. The main design requirements are therefore given, together with illustrations and descriptions of a few types. Heavy current contacts are seldom required and are therefore omitted.

Infrequent operation, oxidization, dirt deposits and changing weather conditions all tend to promote adhesion. In countries where snow and frost are experienced, freezing up also must be overcome or avoided. A well-designed contact caters for these conditions. Three such types are shown in Figs. 74A, 74B, and 74c.

In 74A the complete fixed contact is enclosed in a housing in which a flared slot is incorporated to allow blade access. Note that the contact fingers are made self-aligning by floating them on springs.

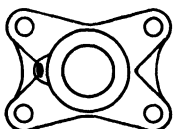
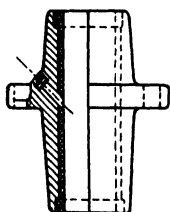

FIG. 72. LIGHT TYPE ISOLATING SWITCH BEARING FOR ROTATING POST INSULATOR

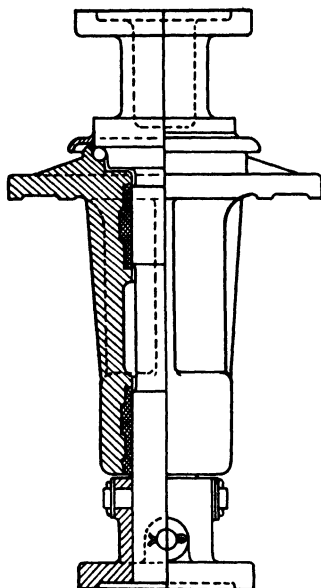

FIG. 73. HEAVY TYPE ISOLATING SWITCH ROTATING SHAFT AND BEARING FOR POST INSULATOR

The contact in 74B has no housing or shield of any kind. Contact is made by a toggling moving contact arm forcing itself between a contact block and a strong horse-shoe spring. The leverages are such that a wiping action of increasing pressure is applied during closing which cleans away dirt, oxide or ice. The contact pressure when closed is 250 lb. along a half-inch line. On opening, the twist imparted to the blade tail and the deflection of the horse-shoe spring successfully shatter any ice accumulation.

In 74c the contact proper is situated on the moving blade,

protected by a top shroud or roof. A cleaning action occurs as the moving contact passes over the fixed knife edge.

Fig. 75 shows a cheap form of contact, modifications of which are used by many makers for pole operated isolators, up to 44 kV.

Where excessive oxidization is encountered, copper or brass

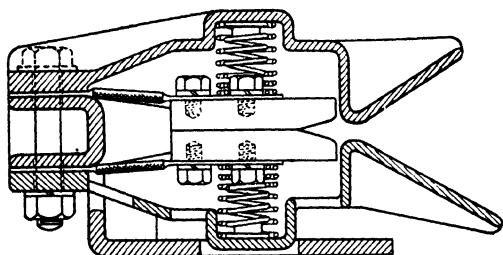

FIG. 74A. SELF-ALIGNING SHROUDED CONTACT
(*British Thomson-Houston Co.*)

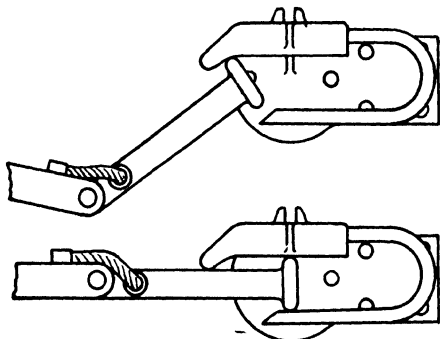

FIG. 74B. HIGH PRESSURE TYPE CONTACT
(*Metropolitan Vickers Elec. Co.*)

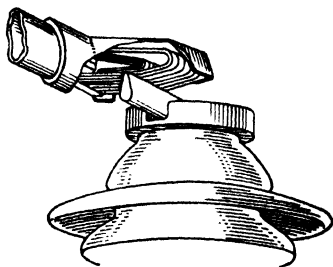

FIG. 74C. SHROUDED SELF-CLEANING CONTACT
(*A. Reyrolle & Co.*)

parts forming a contact face should be either tinned or coated electrically with silver or cadmium. In certain cases silver inserts have been used. Where conditions are reasonable, a slight coating of grease is sufficient, and lanoline is recommended for such use.

Mechanical Operation. Here again the scope for the designer is so large that many types of operating gear are used and generalities only can be given.

The force required at the operating handle is directly governed by the type of contact used, therefore as the contact load varies so does the mechanism employed change. Even when contact loads are the same there is still variation due to differing points of view. Some makers will favour simplicity provided that the power required at the handle is not excessive. Others may add additional mechanism in order that operation can be accomplished with comparatively little effort.

The interconnection between the operating mechanism and the switch, also between the separate phases, may include tension, compression or torsional members.

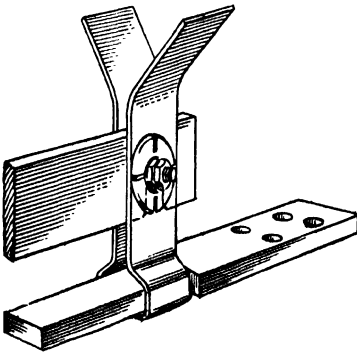

FIG. 75. CHEAP TYPE CONTACT

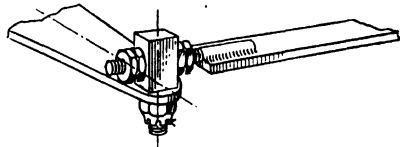

FIG. 76. END DETAIL OF PHASE INTERCONNECTING ROD FOR SMALL PHASE CENTRES

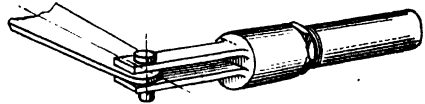

FIG. 77. END DETAIL OF PHASE INTERCONNECTING ROD USING A SCREWED TUBE IN TENSION AND COMPRESSION

As one example, the phase interconnecting mechanism for rotating insulator types of switch can be taken. For small phase centres, say up to 42 in., a flat iron bar which is placed alternatively in tension or compression is quite satisfactory. (Fig. 76.) With increasing spans a single steel tube with screwed clevis ends can replace the flat iron. (Fig. 77.) When the phase centres become greater than 72 in., two smaller diameter tension tubes may be used, so arranged that they take the operation alternatively. (Fig. 78.) Note that in this case clamp fittings are shown which avoid the weakening of the tube by screwing, and the difficulty of successfully galvanizing the threads.

A further example is the interconnection between the operating handle and the switch itself.

The rocker type of switch drive is usually one of two schemes.

For small switches having light contacts a single vertical tube is placed alternatively in tension or compression. Heavier switches are operated by tension members only; these may be solid rod, tube or wire rope. Although the use of wire rope is tempting, it has the disadvantages of stretching and corrosion.

When considering rotating insulator switches, the simplest type of drive is arranged by connecting a vertical tube to the insulator rotating shaft at one end and to the handle at the other. Operation is effected by rotating the tube. Slight twist is unimportant as the travel lost can be regained by

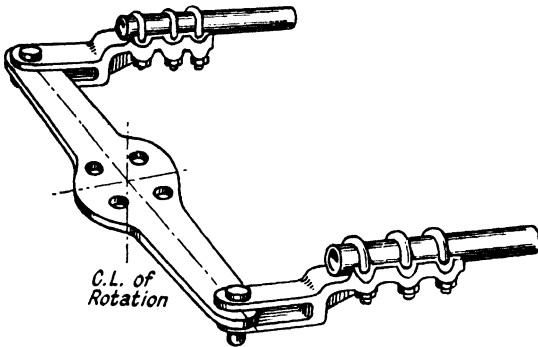

FIG. 78. END DETAIL OF PHASE INTERCONNECTING ROD FOR LARGE SWITCHES USING TUBES IN TENSION AND CLAMP FITTINGS

taking the handle through a slightly greater angle than that required by the switch. With increasing loads a system of toggles is employed and in some cases gearing or levers arranged to increase the angular movement of the operating handle.

Fig. 79 shows the principle of a geared operating handle which rotates the switch through 90° when the handle travels 180° . Fig. 80 illustrates a lever arrangement accomplishing the same duty, through a reciprocating vertical shaft.

Dimensions. Overall dimensions of the various types of switches are given in Figs. 61, 62 and 65. These figures may be taken as representing present-day practice. The dimensions which cause most controversy are the pole and phase spacings.

Pole Centres for Isolating Switches. The actual clearance between poles of the same phase should be such that the arc-over voltage between them, with the switch open, is at least 10 per cent greater than the arc-over voltage to earth. This

is to ensure that isolated apparatus will not be energized by an arc-over from the live side of the switch. In cases where it is necessary to fit large insulators to counteract fouling, arcing horns should be fitted to them so as to preserve the arc-over ratio given.

Pole Centres for Load-breaking Switches. The total length of break at the arcing horns is usually a function of the pole centres. For this reason the dimensions suitable for isolators

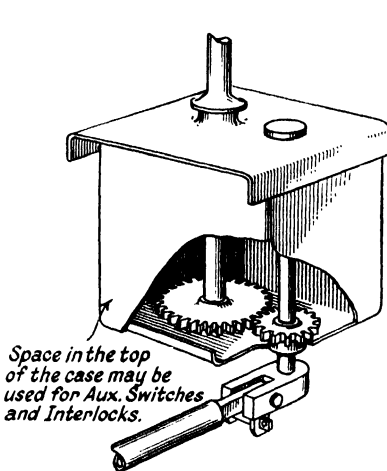

FIG. 79. ISOLATING SWITCH OPERATING HANDLE GIVING 180° ROTATION OF THE HANDLE FOR 90° ROTATION OF THE SWITCH

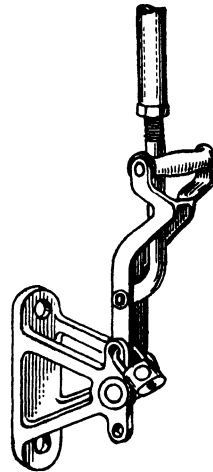

FIG. 80. ISOLATING SWITCH OPERATING HANDLE ARRANGED FOR 180° TRAVEL

are usually exceeded. The length of break required at the horns is determined by the switch design.

Phase Centres for Load-breaking Switches. The breaking capacity of all load-breaking switches, irrespective of type, is influenced more by phase centres than by any other dimension. It is this spacing that decides whether the switch will be reasonably immune from short circuits caused by the arcs being blown together.

The dimensions given in Figs. 61, 62 and 65 are, in the opinion of the authors, the minimum for reasonable reliability. It will be noted that the same dimensions are given for horizontal and vertical break. Provided the horn shapes are similar to Fig. 81 (c) and (d) the arc is struck well above the switch itself and

the spacing between the arcs is approximately the same for both types of break.

The Load-breaking Capacity of Outdoor Air-Break Switches. Chapter VII has dealt with arc phenomena and matters affecting breaking capacity. These data have been given primarily to aid the better understanding of oil circuit-breaker problems.

Much of the information, however, is applicable to arc-

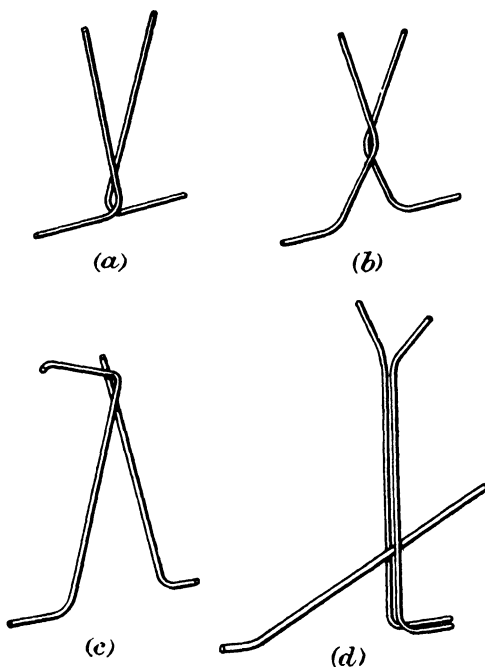

FIG. 81. AIR-BREAK SWITCH HORNS

breaking in air. The normal outdoor air-break switch is not intended to be a competitor of the oil circuit-breaker. Its main sphere constitutes the switching of normal load currents. Overload and short-circuit protection is in most cases provided by other apparatus. When designed and installed correctly, an air switch is capable of handling considerable power. The number of organized breaking tests has been few, presumably owing to their high cost when compared with the value of the switch. Data on a few tests are given at the end of this chapter.

The assignment of breaking capacity is not a matter of precision. Apart from the variables previously enumerated for oil circuit-breakers, two further entirely uncontrollable elements are introduced, wind, and the state of the atmosphere.

Arc-breaking in Air. The drawing of an arc is unavoidable when breaking a circuit in air. It is the duty of a switch so to increase the resistance of the arc path that the potential difference across the switch break is no longer capable of maintaining the arc. This can best be accomplished by increasing the arc length. By this means the potential gradient in the arc is reduced in two ways, first by lengthening it and secondly by introducing into its path unionized air.

It is generally the case that during the major part of the switch travel, the r.m.s. current in the arc will decrease but little, irrespective of the opening speed. The fact is important for two reasons.

In the first place, the speed of break is in most cases under the direct control of operators, and the varying times taken by different men is of minor importance.

The second point is that the final stretching of the arc takes place with the switch stationary, therefore full use must be made of any available means of arc extending and deionizing.

The three principal aids are magnetic blow-out, convection, and wind.

Magnetic Blow-out. The effect of magnetic blow-out varies with current. It is, however, possible to increase its action considerably by a correct design of arcing horns. Fig. 81 (*a*) shows the type of horns used in early designs. The arc is formed at the base of the horns and depends on convection to start it upon its upward path. The magnetic blow-out effect can only come into operation after a loop has been formed. Fig. 81 (*b*) illustrates a modification which partly cures this defect. The loop is, however, rather small. The main idea with both these types was to provide paths along which the arc could rise and thereby extend.

The angle of the horns is critical. If too acute, the arc is reluctant to leave the base of the horns, especially when separated at speed. In other cases it is inclined to swing down and go to earth. This type of construction is seldom used on modern switches.

Fig. 81 (*c*) and (*d*) show two horns of a later design. (*c*) is suitable for horizontal and (*d*) for vertical break. In both these

cases the arc is drawn at the extreme ends of the horns, and forms the top of a magnetic loop of good proportions.

Further, shorts to earth are avoided as the point of break is well above earthed metal.

The switch in Figs. 21 and 22 is fitted with horns (*c*).

Convection. Convection is a direct function of the current. The greater the current, the greater the heat generated and the greater the convection currents which help to lengthen the arc. The beneficial effect is partly countered by the fact that increased currents also mean increased ionization.

In order to make full use of convection, the free air space beneath the arc should be as generous as possible.

Wind. It is perhaps incorrect to classify wind as an aid. Its presence in any case is uncertain. In cases where it blows directly across phases a short circuit may be caused. It does, however, often help in stretching the arc. A high wind will usually snap out an arc when it is comparatively short, due to the rapid deionization brought about by the high velocity of the air passing through the arc. It is sometimes claimed that a light breeze is the worst wind condition in that it is not strong enough to blow the arc out, but aids it in wandering. A well-designed switch should be capable of breaking without the aid of wind.

Load-breaking switches can be divided into two sections: one for breaking normal load currents at commercial power factor, and one for transmission line control. The duty imposed on the switch differs in each case.

Load-Breaking at Commercial Power Factor. Normal load currents seldom have a power factor of less than 0.8, therefore there is but little voltage across the switch break to re-establish the arc at the instant of current zero. A correctly designed switch will give reliable service, although its operation will be influenced by weather, which in particularly adverse cases may cause incorrect operation. An operating efficiency of approximately 95 per cent can be expected.

The currents to be dealt with seldom exceed 300 A. This value is by no means the maximum current that can be handled. The highest power known by the authors to have been successfully broken on an outdoor air-break switch is 4 500A. at 30 kV. This was accomplished on a horizontal break switch. Tests have been taken at various times in the U.S.A. to demonstrate load-breaking ability. The published information

is, however, meagre, and in some cases contradictory. The statements given do appear to confirm the operation efficiency figure of 95 per cent. Records of a series of ten tests carried out by Metropolitan-Vickers Co. in 1933 are given to illustrate breaking characteristics.

SWITCH DATA: Two insulator, horizontal, single break type air-break switch pole centres 31 in. 60 in. phase centres. Horns



FIG. 83. HORIZONTAL AIR-BREAK SWITCH BREAKING 250 A.
AT 30 KV.

The bright ring in the left-hand arc is an indicating lamp. Arc just about to break.

(Metropolitan-Vickers Elec. Co. Ltd.)

as per Fig. 81C. Operation was effected by an overcurrent tripping device fitted to the switch.

TEST DATA: Line voltage 30 kV. Currents broken varied between 164 and 278 A. Arc duration varied between 61 and 76 cycles. Duration of short varied between 73 and 88 cycles. No wind. All tests successful. Fig. 82 shows an oscillogram of one of the tests. Fig. 83 shows the arc just before breaking. Fig. 84 was taken at the approximate completion of the moving arm travel.

Breaking Line-Charging Currents. A line-sectioning switch will at times be called upon to break the charging current of an open-ended transmission line. Let E be the peak value of the phase voltage of the line before the switch opens, and consider the time t_0 when the current passes through zero. The voltage at both sides of the switch is, at this instant, equal to E .

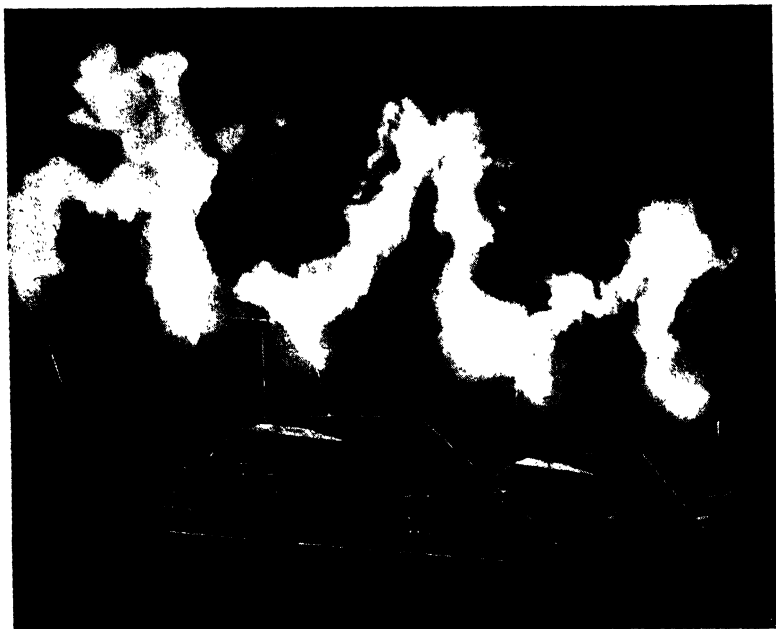

FIG. 84. HORIZONTAL AIR-BREAK SWITCH BREAKING 278 A.
AT 30 kV.

The moving contact has just completed its travel, shown by the vibration of the moving horns. All arcs are clear of each other.

(*Metropolitan-Vickers Elec. Co. Ltd.*)

Now consider when the switch contacts are parted, and, at some time t_1 , when again the current passes through zero, and ignore the arc volts. At this instant t_1 , the voltage of each contact is practically E , see Fig. 85 (b); but, while the line contact will remain at this voltage, except for line losses, the voltage on the other contact will follow that of the system. Therefore, in half a cycle after instant t_1 , say at instant t_2 , the voltage of the contact on the supply side of the switch will be $-E$, whilst that on the line side is still E , see Fig. 85 (c). Thus there is a

pressure of $2E$ across the contacts to restrike the arc. As the switch opens, there will be periods when the breakdown value of the contact gap will be less than $2E$, in which case the arc, after the zero pauses, will restrike before the value $2E$ is reached. Also, there will be a certain gap length which the pressure $2E$ cannot break down, and it is when this length is reached that the arc will not restrike, and the switch will have opened the circuit.

In addition to the above, there is the question of voltage transients, sometimes called *switching surges*, which are set up as a result of the arc remaking. Consider the instant when the arc restrikes, when the voltage across the gap is $2E$. At this instant the voltage of the line is E and the voltage of the supply side of the switch $-E$, and when the arc strikes, the line tends to become charged negatively. This is not effected instantaneously, because of the finite time required for the propagation of the charge. There is in consequence a travelling wave started along the line, which, on a fifty mile line, would reach the open end in $50/186\ 000 = 0.00027$ sec., see Fig. 85 (d). At the end of the line this wave will reflect and the voltage double,

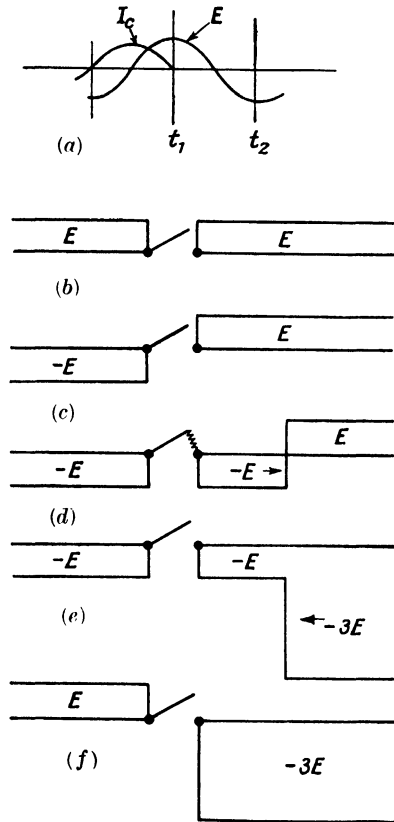

FIG. 85. VARIATIONS OF VOLTAGE ACROSS SWITCH GAP THAT OCCUR WHEN BREAKING LINE-CHARGING CURRENTS ON AN OPEN-ENDED TRANSMISSION LINE

- (a) Voltage and charging current curves for open-ended transmission lines.
- (b) Voltage distribution at instant t_1 .
- (c) Showing effective voltage of $2E$ across gap to restrike arc at instant t_2 .
- (d) Showing voltage wave $-E$ propagated along line as a result of arc restriking.
- (e) Showing voltage wave reflected by open end of line and of value $-3E$.
- (f) Showing next half cycle of system voltage wave which gives an effective voltage across gap of $4E$.

with the result that there will be a voltage wave travelling back to the switch of value $-3E$, see Fig. 85 (e). When next the current passes through zero, the line side is at $3E$, and half a cycle later the supply side is at E ; thus a pressure of $4E$ becomes possible to break down the gap, see Fig. 85 (f). If the gap breaks down again, a wave of value E is propagated along the line, and, at the end of the line, doubling will again occur with this time a returning wave of value $5E$; and so on. The limit to this building up of transient voltages is probably due to line losses, etc. It is, however, believed that as much as five or six times normal voltage can occur across the switch contacts from such causes, and this is sufficient to indicate the cause of the difficulty experienced in breaking line charging currents.

The actual currents to be broken are small in comparison to those of power loads, but it must not be believed that it is only the line charging current that is to be broken. This is only true for the first instant, for after that, due to the restriking of the arc, there will be current transients set up in a manner similar to the voltage transients.

The magnitude of these currents is limited due to the decay resulting from the line surge impedance.

The severity of the above conditions reduces considerably the currents that may be successfully broken. Twenty amperes may be taken as an approximate limit at 33 kV. and ten amperes at 115 kV. These values may appear low at first sight, but charging currents in many cases fall within this range.

The arc which draws out to a length far in excess of a power arc of many times its current value has the appearance of a luminous waving string. The extended length and the resultant large cooling surface, together with the continuous movement of the arc through unionized air, results in final rupture. Switches used for this duty should be mounted at as large a phase spacing as possible. The switch horns must be the highest point on the complete structure, thus leaving the space above entirely free.

A record of field tests taken by the New Zealand Public Works Department at 110 kV., three-phase, 50 periods, is given below.

SWITCH DATA: Three insulator revolving post type vertical break air-break switch. Pole centres 4 ft. 6 in., phase centres 12 ft. Horns as per Fig. 81 (d).

The charging current of a 25 mile transmission line, which was approximately 8 A., was readily broken in good weather conditions. A 60 mile line having a charging current of 20 A. was not satisfactorily broken. The excessive arc lengths for currents above 10 A. made their rupture precarious.

Earth Switches. In order to ensure safety during repair or maintenance work on the transmission lines, it is customary to arrange that such lines are not only isolated but adequately

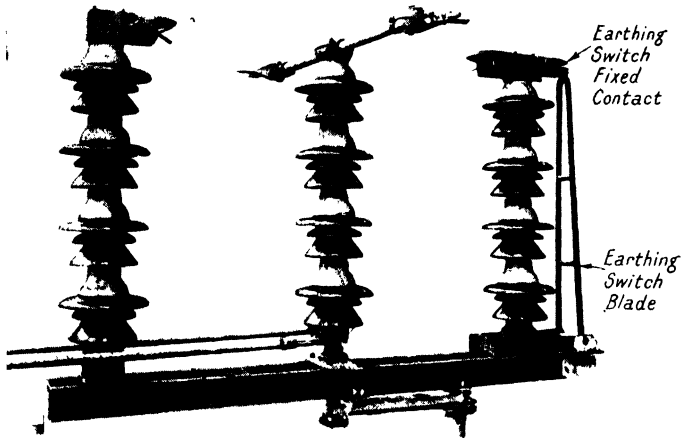

FIG. 86. 132 kV. ISOLATING SWITCH WITH EARTHING SWITCH
(Metropolitan-Vickers Elec. Co. Ltd.)

earthed. This earthing is generally effected by one of two alternative methods, thus—

(a) The isolating switches controlling the lines are fitted with earthing contacts such that, when the isolating switch blades are moved to the open position, they can, for the purpose of earthing, be opened still more until they engage with these earthing contacts. The earth contacts are generally mounted on a bracket, supported directly on the main switch base, and a copper earthing strip is taken from the base to the earthing network of the system. With this method it is clear that the isolating switch must be mounted so that the blade is connected to the line side. No interlock is required, since, from the nature of the arrangement, it is impossible to have the switch blade in the closed and earthed positions at the same time.

(b) A separate switch for earthing purposes is fitted, although this may be incorporated with the line isolating switch. For example: an additional jaw contact is fitted adjacent to the main contact at the top of the stationary post insulator of the isolating switch, Fig. 86. The earthing blade hinge bearing is mounted at the base of the same insulator post. Thus the combination must be installed with the isolating switch blade on the station side of the equipment, and the fixed contact on the line side. A separate operating gear controls the earth blade, and an interlock is necessary between this operating gear and that of the isolating switch, so that it is impossible to have both of these switches closed at the same time.

BIBLIOGRAPHY

- C. H. Bennett, *Elec. World*, Oct., 1915.
"Pole Top Switch Tests," *Elec. World*, Oct., 1925.
Raymond C. R. Schulze, *Elec. World*, April, 1927.

CHAPTER VI

CONTACT PRESSURE AND TEMPERATURE RISE

It is known that the conductance of a pair of contact faces, however smooth and well bedded, will not be the same as the conductivity of the metal itself. In all cases the conductance is less. This means that for a given current density there will be a greater watt loss across such contact faces than there is through the same proportion of the metal itself. In consequence there will be a greater generation of heat, and this will tend to establish a higher temperature at the contact faces than that which occurs in the conductor proper. Temperature rise is therefore the limiting feature of all contact design.

The value of the conductivity given by the metal can never be equalled by the conductance across a pair of contact faces, because it is impossible in practice to press the surfaces together with a force sufficient to flatten out all the minute protuberances such that molecular spacing would be obtained. It is, however, reasonable to expect that the greater the pressure put across the contacts the greater will be the degree of compression, and therefore the nearer the approach the conductance will make to the 100 per cent value as represented by the conductivity of the metal. That this is so is demonstrated by the tests which show that the voltage drop across a pair of contacts varies directly as the current and inversely as the contact pressure. This may be expressed in the form of an equation, thus—

$$V = IK/P \quad . \quad . \quad . \quad . \quad . \quad . \quad . \quad (5)$$

where V equals the voltage drop across the contacts, I the current, P the contact pressure, and K a constant dependent upon the metal and nature of the contact surfaces.

Schaelchlin has investigated this question of contact pressure on the basis that all contact surfaces are made up of numerous points, some more protuberant than others. As the pressure increases, the most prominent points become depressed and allow other points, hitherto separated, to come into contact. Furthermore, when the projections are depressed they increase in lateral dimension, and thus provide larger contact surface

and current carrying capacity. This effect acts to reduce contact resistance and therefore the I^2R loss.

For clean copper surfaces Schaelchlin gives the value of K as being equal to 2.3×10^{-4} , but in practice this may vary

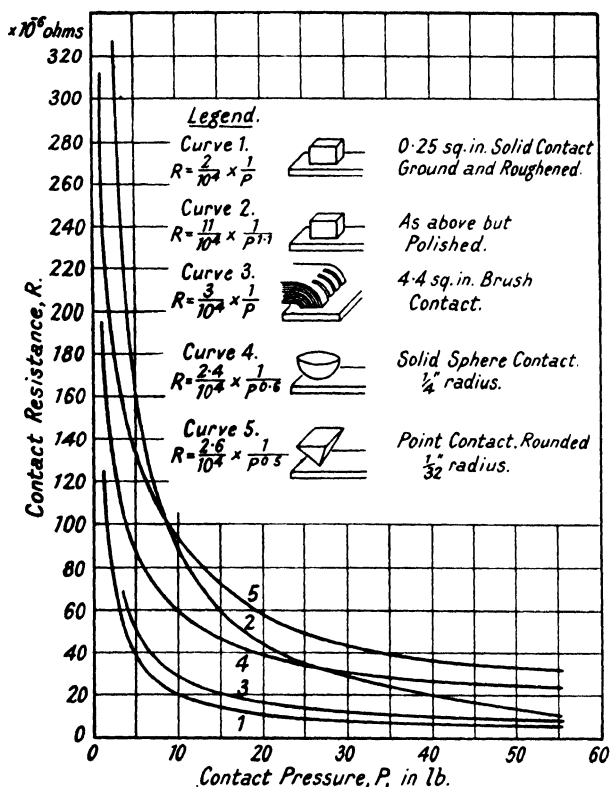

FIG. 87. VALUE OF THE CONSTANT K FOR DIFFERENT TYPES OF CONTACTS

(From paper by O. Schaelchlin)

somewhat dependent upon the nature and condition of the surfaces in question. If then the correct value can be assigned to the constant K , the watt loss across a pair of contact faces can be determined from equation 5. In Fig. 87 a series of curves is given which is taken from Schaelchlin's paper. From these can be derived the value of K for different kinds of contact surfaces.

The energy represented by the watt loss across a pair of contact faces is converted into heat, so that the contact faces become a source of heat supply, and therefore the temperature of these surfaces, and of those of the adjacent conductors, will rise until thermal balance is reached between the heat generated and that lost by conduction, etc. The heat generated at the contacts is dissipated through the conductors connected to the contacts, and lost from the surfaces of those conductors by radiation, convection and conduction through the surrounding medium. Thus if H is the total heat lost from the surface, and H_r , H_c and H_s that lost by radiation, convection and conduction respectively, then

$$H = H_r + H_c + H_s$$

In addition to the heat from the contact faces, there is the heat generated in the conductors by virtue of their resistance. Therefore, if H_a and H_b represent the heat supplied from the contact faces and from the conductors respectively, then H , the total heat lost from the surfaces, is equal to the sum of these, or

$$H = H_a + H_b$$

The value of H in watts can be obtained from equation (5), thus—

$$H = I^2 K / P$$

Therefore, if a value can be found for K , this equation gives the relationship between the heat generated by a given current, and the contact pressure, whence the resulting temperature rise can be calculated.

The heat losses from the conductor surfaces are, however, different functions of the temperature difference between conductor surfaces and surrounding medium. Thus the loss due to radiation is found to vary as the fourth power of this temperature difference, whilst the convection loss is governed by the $\frac{3}{4}$ th power. The equations for all these losses can be obtained from a standard treatise on Heat.

The temperature of the conductor surfaces due to the heat from the contacts is, however, not constant along the conductor, but follows an exponential law of the order

$$\theta_x = \theta_0 e^{-\mu x} \quad \dots \quad (6)$$

where θ_x is the temperature at a point distant x from the contacts, and θ_0 the temperature of the contacts; whilst $\mu^2 = dp / \kappa A$, where d is a dissipation coefficient, p the perimeter of

the conductor, κ the thermal conductivity of the metal, and A the sectional area of the conductor.

It will be appreciated that the calculation for the value of H to be substituted in equation (5) is somewhat complex, particularly when the contacts and conductors are of irregular shapes. In general, it can be taken that for contact surfaces subject to the action of salty or polluted atmospheres, high contact pressure is an advantage, because the area of the contact surfaces can be reduced in proportion to the increase in pressure, as given in equation (5), and the reduced area offers a smaller scope for the action of the atmosphere. As an example, for currents up to 600 A. a line contact about half an inch long under a pressure of 150 lb. will be found to be adequate.

BIBLIOGRAPHY

Fishenden and Saunders, *Calculation of Heat Transmission*. H.M. Stationery Office.

Schaelchlin, *Éléct. Journal*, Vol. XXV, No. 8.

CHAPTER VII

ARC INTERRUPTION PHENOMENA

THE THEORY OF ARC INTERRUPTION

To interrupt the flow of current in an electric circuit it would appear to be necessary only to pull two contacts apart: yet by doing this one of the most complex problems in the whole range of electro-physics is presented. When two such contacts are separated, the result is the establishment of an arc between them. The phenomena involved in this arc constitute the problem referred to.

Although the study of the arc has progressed considerably in recent years, it is by no means complete, and, in this chapter, the endeavour to give an introduction to the subject is necessarily based on the science as it stands to-day. It is therefore subject to the somewhat changing views that are a consequence of the rapid advance of physics.

Before dealing with the arc it is advisable to consider what is happening in the conductors that form the circuit prior to the separation of the contacts. The atoms of which a metal is composed are known to be electrically neutral, though each is regarded as consisting of a central small nucleus bearing a large positive charge surrounded by a cloud of electrons or unit negative charges. The total negative charge borne by these electrons is equal to the total positive charge on the nucleus, and all atoms of the same element, copper for example, have identical nuclei and the same number of surrounding electrons. Most of these electrons are bound to the nucleus by very strong forces, and in arc phenomena these electrons are never separated from the nucleus. The remaining electrons are, however, bound by very weak forces and it is these weakly-bound electrons that play a role in the phenomena of conduction, whether metallic or gaseous. The nucleus together with the tightly-bound electrons may be regarded as a unit, which is obviously electro-positive, and is called the *positive ion*. This, together with one or two loosely-bound electrons, comprises the atom as a whole. The Rutherford-Bohr model of the atom pictures all these electrons revolving in different orbits around the nucleus like planets around a sun, the loosely-bound

electrons corresponding to the most remote planets of the system.

At normal temperatures a metal consists of an assembly of small crystals, each crystal being composed of atoms of the metal spaced at regular intervals at distances of about 2×10^{-8} cm. apart. Though the mean positions of the atoms are fixed, each atom is in a state of rapid motion depending solely upon the temperature of the metal, and those electrons most weakly attached to the atom frequently find themselves in a field-free space between adjacent atoms. If, then, a potential difference

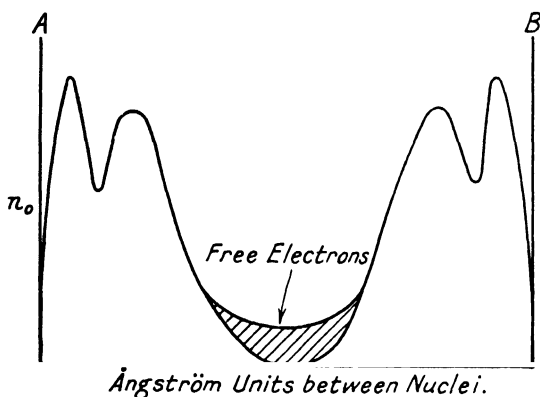

FIG. 88. ELECTRON DISPOSITION IN A METAL

The humps in the two curves correspond to the frequency of the various quantum shell electrons. The lines *A* and *B* represent the nucleus position between any two atoms of the metal.

is established in a metal, these loosely bound electrons will be able to move under its influence no matter how small, and it is this electron drift that is measured as current.

It is impossible in the present work to expound the different theories of electrical conductivity in metals, the early theory of Drude which supposed the electron to be moving freely through the metal and obeying the gas laws, the later theory of Lindemann which placed the free electrons at the corners of a "lattice" that dovetailed into the crystal lattice of the metal positive ions, and finally to the latest theories of Sommerfeld based on the wave theory of the electron. The common feature of all theories is that there would appear to be about one electron per atom associated with the process of conductivity, and that the electrons are free to drift under the smallest applied potential. (Fig. 88.)

When the electrons approach an outer boundary of a crystal aggregate, they reach a position where the net resultant force on them is directed inwards from the boundary, the force increasing towards the boundary. Whether electrons can escape beyond this boundary depends upon their energy, a minimum or threshold value being necessary, which value is a characteristic of each metal. Under normal conditions, electrons do not possess this necessary threshold energy, but energy may be given to them by various means—

1. By the incidence of light radiations of a sufficiently short wavelength.
2. By increasing the temperature of the metal.
3. By the application of strong electric fields to the surface of the metal.

When a circuit in which current is flowing is suddenly broken it is not to be expected that the electron drift will be arrested instantaneously without a display in some form or other of the energy with which it was invested prior to the opening of the circuit. Such display is seen in the arc or spark which accompanies the interruption, and it is necessary to examine which of the three methods outlined above becomes operative in allowing the conductivity electrons to escape from the boundary of the metal. When light radiation falls on a metal surface its energy is absorbed by the atoms of the metal, and it has been observed experimentally that, under certain conditions, free electrons leave the surface of the metal. The Quantum Theory has given a quantitative explanation of this phenomenon, and briefly the energy of motion with which the escaped electrons leave the surface, i.e. $\frac{1}{2}mv^2$, is equal to the difference between a constant, depending on the wavelength of the light used, and a constant depending on the metal. Or

$$\frac{1}{2}mv^2 = hn - w \quad . \quad . \quad . \quad . \quad . \quad . \quad (7)$$

where m is the mass of the electron, v its velocity, n the frequency of the monochromatic light, h is Planck's constant and w is a constant for the given metal. w may be regarded as the energy the electron requires to escape from the forces of attraction of the positive ions of the metal, and it can be expressed as the product qV_0 of the electron charge q and a potential difference V_0 . For the element copper, it is found that the light of longest wavelength which will just liberate an electron from a copper surface, the electron appearing in free

space with almost zero velocity, is 1 600 Ångström units, which corresponds to a light frequency of $\frac{3 \times 10^{10}}{16 \times 10^{-6}} = 1.87 \times 10^{15}$ cycles per sec., and a light quantum energy of $6.55 \times 10^{-27} \times 1.87 \times 10^{15} = 1.23 \times 10^{-11}$ ergs.

As the electron has almost no free energy under these conditions, $\frac{1}{2}mv^2 = 0$, and the escape energy of the electron becomes

$$hn = 1.23 \times 10^{-11} \text{ ergs} = qV_0 = V_0 \times 4.77 \times 10^{-10} \text{ ergs.}$$

$$\text{From which } V_0 = 7.8 \text{ V.}$$

That is, the electron experiences a total retarding force corresponding to an electric gradient of 7.8 volts. This force is called the *photo-electric work function* for the metal.

Regarding the second method by which electrons are known to be enabled to leave a metallic surface: briefly, when the temperature of the metal is raised, and an electric field is established at its surface, the rate of emission of electrons is an exponential function of the temperature, thus

$$I = AT^2e^{-b/T} \quad . \quad . \quad . \quad . \quad . \quad . \quad . \quad (8)$$

where I is the emission current, T the absolute temperature, and A and b constants. A is theoretically a universal constant for all metals, but b is characteristic of the metal, and is associated with the work done on an electron in leaving the surface, i.e. the *thermionic work function*. This thermionic work function and the photo-electric work function are now known to be identical in the case of very pure metals. Both are changed differently if impurities are present; the change being in the direction of lower values.

Regarding the third method, the potential gradient necessary to produce electron emission at the surface of a metal is of the order of 10^5 volts per centimetre, and the law of emission is given by

$$I = BF^2e^{-c/F} \quad . \quad . \quad . \quad . \quad . \quad . \quad . \quad (9)$$

It is of the same form as that for thermionic emission. F is the field strength, and the constant c contains the thermionic work function again.

Now consider the condition in an oil circuit-breaker at the moment of breaking circuit. When the contacts first part gas will rush into the gap, but as the spacing is extremely small the

pressure in the gap will certainly be less than atmospheric pressure. Now the electric strength of a gas gap varies directly with the pressure, down to quite low pressures; therefore, at small spacings of the gap the conditions for the initiation of a spark are very favourable. At the same time, if the contacts start to separate at the moment current is flowing through them, there will be an extremely rapid rise of voltage across the gap and conditions will then be favourable for the conductivity electrons to be dragged out of the negative contact, as outlined in method 3. This is probably the first process in the formation of an arc between the contacts. When open only 10^{-5} cm., for example, there may be as much as a hundred volts potential difference between the contacts. This would give a field strength well in excess of that required to drag the electrons from the cathode contact. This voltage difference alone would not be sufficient to cause ionization, as it is below the minimum critical sparking voltage for air, but the current flowing from the cathode under the action of the intense field can readily ionize the gas molecules as they rush into the widening space between the contacts. Under the action of the field the positive gas ions travel towards the cathode, delivering a considerable energy to the cathode on account of their large mass. The cathode in turn heats up under the positive ion bombardment, and in a very short time the second method of releasing electrons from a surface becomes operative. Thus thermionic emission sets in, and is of a far larger order of magnitude than the so-called *autoelectronic* emission which started the sequence of the ionization processes. No doubt, also, the intense ultra-violet light radiation, emitted during the first few ionizing collisions, calls into play the first method referred to of liberating electrons, but it is not possible to define the importance of this agent quantitatively.

When the system voltage is in phase with the current, no current will flow across the gap when the field across the gap is zero; but the cooling of the hot spots on the electrodes may not be sufficient to entirely prevent thermionic emission, so that when the potential increases once more ionization will follow. Also, the residual ionization in the arc gases may be adequate to start the arc when the potential builds up.

When $\cos \phi$ of the circuit is less than unity there will be a greater probability of the arc restriking after a current zero point than would be the case for a circuit in which $\cos \phi$ were

equal to 1. This is because the acting value of the voltage is greater in the former case than it is in the latter. Thus the power factor will have a definite effect upon arc interruption. This is treated in more detail in the section dealing with restriking voltage. See Fig. 89.

The initiation of the arc, then, is a process whereby the electrons are liberated from the metal by the action of the intense electric field which exists when the contact gap is very small. When these electrons leave the cathode contact they proceed towards the opposite

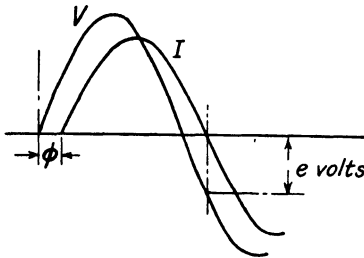

FIG. 89. VOLTAGE AVAILABLE (e) TO RE-STRIKE ARC AFTER A CURRENT ZERO POINT FOR A CIRCUIT WITH A POWER FACTOR OF $\cos \phi$

contact under the action of the field, gaining energy as they go. During this passage to the opposite electrode they collide with neutral gas atoms, and, in the collision process, generally lose energy and ionize the atom by ejecting an electron from its structure. Thus the number of electrons liberated by one electron increases rapidly in the passage from one contact to the other. Another possible collision process is that occurring with an atom that has

already lost one electron. This collision may result in recombination of the positive ion with the electron to form a neutral atom once more. Owing to the larger mass of the positive ion, its motion under the action of the field is much slower than that of the electron, and most of the arc current, i.e. 90 to 98 per cent, is carried by the free electrons. The positive ions form a space charge which remains more or less immobile between the contacts.

The whole of this action is dependent in extent upon the pressure of the gas in which it occurs, because the greater the gas pressure, the greater the density, and therefore the shorter will be the mean free path of translation. For the same reason the result is governed by temperature. It will be gathered from the above that the movement of an ion or electron will not be continuous but will result in a series of runs between the collisions. It is generally assumed that when a collision occurs, the electron will lose all its velocity and start again from rest. If the field strength is ϵ and the charge q , the force on the ion

will be ϵq , and its acceleration, if free to move, will be $\epsilon q/m$, where m is the mass of the ion. But, as the path is not free but made up of a series of short runs, this acceleration is not maintained. Instead, the ion moves with a constant mean velocity which will be proportional to the field force ϵ .

Let t be the time taken for an ion to describe its mean free path, then its velocity at the end of this path is

$$V^1 = \epsilon q t / m \quad \dots \quad (10)$$

and its average velocity over the path is $\epsilon q t / 2m$, which is also its average velocity across the gap.

Now, because of the different values that m will have for the different ions, etc., the velocities of the positive and negative ions will not be the same, as is indicated by the equation given above. For any given ion, the term $q t / m$ will be constant, and can therefore be represented by K_1 and K_2 for the positive and negative ions respectively. Therefore, if U equals the velocity of the positive ions and V the velocity of the negative ions, then the above equation can be written

$$\left. \begin{aligned} U &= K_1 \epsilon \\ \text{and } V &= K_2 \epsilon \end{aligned} \right\} \quad \dots \quad (11)$$

These values represent the mobilities of the ions.

Because in the constants K_1 and K_2 the factor t is dependent upon the length of mean free path, it is clear that these constants will vary for different values of gas pressures and temperature. Therefore the mobility of the ions, which is defined as the velocity of the ion in centimetres per second under the action of a field force of one volt per centimetre, is governed by the pressure and temperature of the gas in which it moves.

It follows that the pressure and temperature will also affect the rate of recombination of the ions, since the more dense the gas, the shorter the mean free path, and therefore the greater the likelihood of the electron or negative ion to meet and combine with a positive ion. The rate of recombination R is given by the expression

$$R = dN/dt = - \alpha N^2 \quad \dots \quad (12)$$

where α is the coefficient of recombination and N the number of positive and negative ions per cubic centimetre of the gas path between the contacts.

$$N = N_0 / (1 + N_0 \alpha t) \quad \dots \quad (13)$$

134 OUTDOOR HIGH VOLTAGE SWITCHGEAR

where N equals number of ions at instant t , N_0 number at instant t_0 . Under given conditions the value of R is smaller when the current is large, and greater when the current is small, or

$$\alpha N^2 = K i^{1/N} = R. \quad (14)$$

For air and carbon dioxide, at standard pressure and temperature

$$\alpha \simeq 1.6 \times 10^{-6}$$

For hydrogen under the same conditions,

$$\alpha \simeq 1.4 \times 10^{-6}$$

The higher the current value the greater will be the rate of electron emission from one contact and absorption by the other, and the less the probability of recombination of the electrons with positive ions *en route*. This is a fortunate fact in so far as it means that the rate of recombination is greater about the periods of zero current values than it is for the periods about the peak values. In other words, the rate of growth of the dielectric strength is a maximum about the current zero periods.

The above leads to the conclusion that arc extinction can be brought about by two or three different means—

1. By facilitating recombination within the gap.
2. By lengthening the gap so that between collisions the electrons will not be able to gain enough energy to effect ionization by collision.
3. By preventing or reducing emission at the cathode.
4. By displacement.

Also, arc extinction is impossible until the energy that the electrons acquire by their acceleration in the electric field is less than the ionization voltage of the gas atoms in the gap. The displacement method mentioned in (4) is based on the theory of Prince, and is that in which arc extinction is obtained by displacing, by any means, the arc products from between the arc electrodes, and substituting therefor a good dielectric.

Arc Voltage. Having seen from above that the arc is the flow of electrons and ions from one contact to another through an intervening gas, and that the path of these electrons and ions is subject to intermittent obstructions caused by the

collisions between them, it is not to be expected that the voltage gradient between the contacts will be constant. Actually, this arc voltage takes the form shown in Fig. 90. The cathode potential drop is small compared with that of the anode or positive conductor; while for about 80 per cent of the central portion of the gap the gradient is reasonably uniform. The major portion of the arc is made up of the positive column; the negative dark space is too narrow to be visible.

The voltage distribution given in Fig. 90 is for fixed current values and its general form applies to any fixed value at standard pressure and temperature. For different current

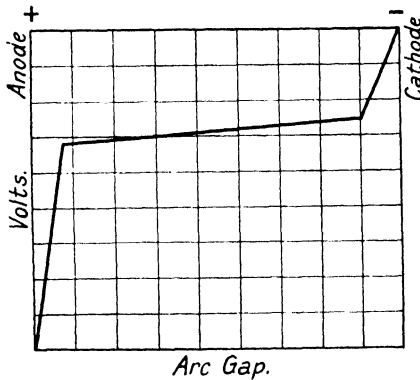

FIG. 90. VARIATION IN VOLTAGE GRADIENT BETWEEN ANODE AND CATHODE OF A PAIR OF CONTACTS BETWEEN WHICH AN ARC PERSISTS

values, while the form of the curve will remain the same, the distribution will vary.

In regard to the oil circuit-breaker arc, this voltage distribution is not considered, but the arc voltage is taken as being that of the mean value across the whole arc.

A number of equations are given by various authorities for arc voltage. For instance there is Mrs. Ayrton's classical equation

$$V_a = a + bl + (c + dl)/i \quad . \quad . \quad . \quad . \quad (15)$$

Prof. Steinmetz gives

$$V_a = a + c(l + \delta)/\sqrt{i} \quad . \quad . \quad . \quad . \quad (16)$$

Norberg changes this to

$$V_a = K_1 + (K_2/\sqrt{i})l \quad . \quad . \quad . \quad . \quad . \quad . \quad . \quad . \quad . \quad (17)$$

And the British Electrical Research Association gives

$$V_a = V_c + (K/\sqrt{i})l + \beta l \quad . \quad . \quad . \quad . \quad . \quad . \quad . \quad . \quad . \quad (18)$$

In these equations V_a is the arc voltage, a, b, c, d, K_1 and K_2 are constants depending upon the material of the contacts, etc., l is the length of the arc and β is the instantaneous voltage per unit length of arc proper.

It is probable that each of these equations, which all profess to express the same thing, is nearly right within the limits of its own application, yet none is strictly correct. Mrs. Ayrton's equation refers to d.c. arcs, short in length, and of about thirty amperes in current strength. On the other hand the equation given by the Electrical Research Association is for long a.c. arcs up to about 1 600 amperes. But the variation of voltage throughout the arc length is very complex, and not one of the above equations will give a correct solution unless the proper values are assigned to the constants. In fact, it is not possible fully to represent arc voltage by any one equation, because it is governed by such things as the composition, condition and history of the contacts on the one hand, and on those of the fluid or gas in which the arc occurs, on the other; as well as upon temperature, pressure, light, etc.

For high current values, the arc becomes fat, in order to supply the current thermionically. In this case the central part of the arc reaches a condition of what can be termed *ionic saturation*. Further increase of current does not then increase the current density of this central portion or core of the arc, but increases instead the cross-sectional area of the arc. This means that the potential drop per unit length of arc will decrease with increasing current until a limiting value of current is reached, after which any further increase in current does not affect the voltage drop. From the theory of ionic collisions, this is to be expected, since when all the atoms in a given volume of dielectric have been ionized there can be no further increase in current density in that volume. In the study of a.c. arcs in general, the values of current dealt with will be high, so that saturation will be reached and the voltage drop will therefore be constant. The curve representing the voltage for about 40 per cent on each side of the peak value of a half

current cycle will be almost a horizontal line, with small ripples superimposed on it due to chance variations of cooling conditions of the arc and many other small disturbing effects. (See Fig. 91.)

Now when approaching the zero value on the system current cycle, the rapid decrease in the current value that occurs about that point results in a corresponding increase in the rate of

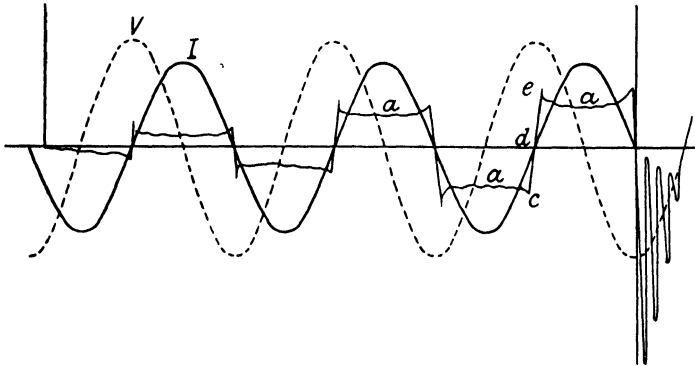

FIG. 91. CHARACTERISTICS OF ARC VOLTAGE CURVE WHICH IS IN PHASE WITH CURRENT CURVE *I* AND 90° DISPLACED FROM SYSTEM VOLTAGE CURVE *V*

recombination in the arc path. This is indicated in the equation

$$\alpha N^2 = K/i^{1/N} \dots \dots \dots (19)$$

This in turn means that the resistance of the arc increases: therefore there will be a rise in the arc voltage curve as it approaches the zero point of the current wave. Immediately after the current has passed through zero the rate of recombination will be at its highest, as also will be the arc resistance. There is, therefore, a somewhat greater voltage rise across the arc after zero than just before it. On the whole there is a violent change about the zero environs.

These variations of the arc voltage are shown in Fig. 91, in which the central portion *a* represents the duration of fairly constant voltage over most of the current half-wave between the current zero points; *cd* is the voltage variation on approaching the current zero point, and *de* the corresponding variation following current zero. The illustration is quite

figurative, and is only a very general indication of what would be observed on an oscillogram. The extraneous influences acting on the arc can affect the voltage curve considerably, but the figure is sufficient to explain the general tendency to which the voltage curve inclines.

From the above it may be expected that the equation to the voltage across the arc will contain at least three terms. One of these will represent the voltage over the middle portion of the half cycle, a in Fig. 91. This is the voltage which is independent of the current but dependent only on the arc length. Another term will represent the voltage in the region of current zero values; whilst a third term will be required to express the potential drop at cathode and anode. The first of these can be represented by βl , where β is a constant and l the length of the arc. The third can be given as V_c , since it will have a fixed value for any given pair of contacts and intervening gas. The second term, which is to express the voltage variation about the zero current point, can be derived from the expression for the rate of recombination of the ions in the arc path, i.e. from equation

$$R = \alpha N^2$$

R has been shown (by equation (14) to be equal to $Ki^{-1/N}$. This voltage term will also depend upon the length of the arc, since N , the number of ions, obviously depends upon the length of the arc path. Therefore, the second term can be written

$$Kl\sqrt[N]{i}$$

The whole equation for arc voltage thus becomes

$$V_a = V_c + (Kl\sqrt[N]{i})l + \beta l \quad . \quad . \quad . \quad . \quad . \quad (20)$$

This equation, it will be observed, agrees with that which has been given by the Electrical Research Association, although the authors are not aware whether that body arrived at the formula by the same reasoning. In the E.R.A. equation, the value of the index N is given as 2, and for the small current values as those about the zero point, $N = 2$ would seem applicable.

For current values of the order of those that occur at the peak of the wave in large oil circuit-breakers, the second term in the equation becomes of small consequence, and can, therefore, in general be ignored. This being so, the arc voltage

varies only as the arc length, plus an allowance for contact drop. Numerous tests have been made by the Electrical Research Association to determine the value of the constant β . An extract from the results of these is given in Table IX.

TABLE IX

R.M.S. Current (Frequency 40 Cycles)	β (Mean) during Arcing	β in Last Half-cycle of Arcing
Amperes	Volts	Volts
140	49	44
260	49	44
460	48	49
455	54	52
730	45	51
1 075	53	37
1 590	44	42

(From Paper by Wedmore, Whitney and Bruce—J.I.E.E., May, 1929.)

It will be found there that the values vary between 44 and 54 volts per cm. for currents ranging from 140 to 1 590 A. The E.R.A. have decided to adopt a mean value of 50 volts per cm. as the optimum figure for arc voltage for currents of this order.

With currents of smaller value, such as those sometimes encountered on high voltage systems, or line charging currents, ionic saturation is not reached, and the above requires a certain amount of modification. For such currents, the variation of arc resistance is, in general, inversely as the square of the current, from which it follows that if V_a is the arc voltage

$$V_a/I \propto 1/I^2 \text{ or } V_a \propto 1/I \quad . \quad . \quad . \quad . \quad . \quad (21)$$

This is expressed as a function by the curve AB in Fig. 92, which has the form of a rectangular hyperbola. The line CD , specified as the resistance line, represents the difference in voltage between that given by the supply and that absorbed by the resistance of the circuit excluding the arc itself. Or

$$V_a = V - v_1$$

where V equals the supply voltage, and v_1 equals the volts absorbed by the circuit, excluding the arc volts. At the points V_p and I_q the voltage and current given by the circuit agree with the values required by the arc. They are therefore points of stability. For any intermediate point x , the voltage given by the circuit for current, I_x is $V_{c,x}$, whilst that required by the

arc for the same current is V_{ax} . From the figure $V_{cx} > V_{ax}$ therefore there is instability in the arc in so far as the circuit is forcing more current through it than is required. For any point y , beyond the stable point P , the voltage given by the circuit for current I_y is V_{cy} , whilst that required by the arc is V_{ay} . In this case $V_{cy} < V_{ay}$; or the circuit is unable to

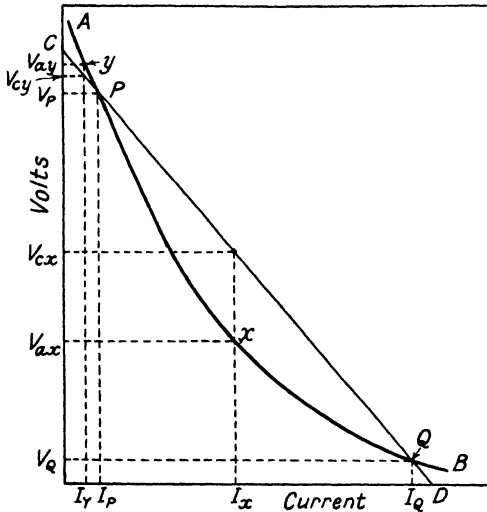

FIG. 92. CHARACTERISTIC CURVE FOR A LOW CURRENT ARC

supply the voltage required by the arc. Therefore this is an unstable point and the arc will extinguish.

The above represents conditions at some constant arc length. There will be an arc characteristic curve of the kind AB for each different length of arc. If these curves be drawn, and a locus of the stable points be drawn for the various arc gap lengths, it will be found that the locus curve ultimately becomes tangential to the resistance line. This tangent point represents the last stable point to be reached in the lengthening of the arc; beyond which extinction of the arc is inevitable. This is shown in Fig. 93.

The above treatment applies to a.c. and d.c. arcs. In the case of an a.c. arc, there is in addition arc hysteresis to be considered. This results from the fact that, with the commencement of a small arc, there is a certain value of voltage associated

with it. As the current increases, this voltage will decrease in value, until, if the increase of current is sufficient to reach ionized saturation, it obtains a constant value. If the current be then decreased, the corresponding variation in voltage will not be the same as it was for increasing current; or, the current-voltage curves are not coincident for increasing and decreasing currents. Actually, the decreasing current curve will lie below that for increasing current. This means there are certain current values for each of which there are two voltage values.

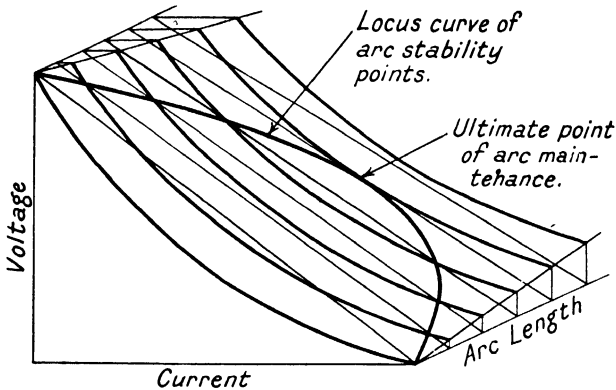

FIG. 93. VARIATION OF ARC CHARACTERISTICS WITH OPENING OF CONTACTS AND ULTIMATE STABILITY POINT AFTER WHICH FURTHER LENGTHENING WILL RESULT IN ARC EXTINCTION

In Fig. 94 the curve AB represents the voltage variation for increasing currents, and curve BC that for decreasing currents. The hysteresis loop is the result of the rate of deionization of the arc path, as determined by the rate of recombination within the arc, not keeping pace with the rate of change of current; the rate of change of current being that due to a 50 or 60 cycle system. The difference between the curves AB and BC for zero current value, i.e. AC , is representative generally of the difference between de and cd in Fig. 91, page 137. There will be a curve of the kind AB shown in Fig. 94 for each half cycle of an alternating current, and the value OA represents the voltage necessary to restart the arc after current zero. The voltage at the end of the half cycle will, of course, be OC , and this will have to increase to OA , as stated above, before the arc will remake.

There will be a series of curves for the current half cycles, and these will differ from each other in so far that, as the contacts move farther apart and the arc becomes longer, the arc characteristic will change accordingly. This is similar to that which takes place with the d.c. arc as the gap widens. These characteristic curves will lie one above the other, and the locus of their peak values will form another curve representing the variations of restriking voltage as the circuit-breaker opens. When the value of this restriking voltage becomes greater

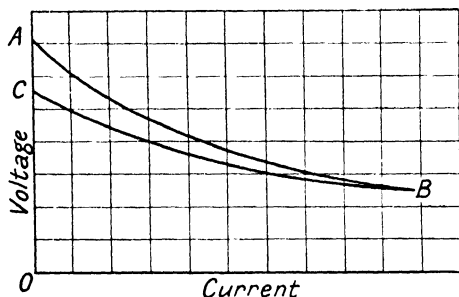

FIG. 94. CHARACTERISTIC OF AN A.C. ARC, SHOWING EFFECT OF ARC HYSTERESIS

than that which the system can supply, the arc will be unable to restrike and the circuit will be broken.

The above is shown graphically in Fig. 95, in which a, b, c, d , etc., are the arc characteristic curves for the different lengths of arc gap as the circuit-breaker opens. OI is the arc current, and OV_a, OV_b, OV_c , etc., the arc voltages for the increasing gaps; whilst OV is the system or restriking voltage. The point X is that at which the arc voltage and system voltage are equal, and is the last stability point. A further increase in gap length beyond X must result in arc extinction, since the system voltage or restriking voltage, as given in the figure, are then less than those required by the arc.

Arc Energy. Having obtained from the foregoing some idea of the variation in the voltage across the arc during a half cycle, and knowing the current strength of the arc, it should be possible to calculate the energy of the arc during this half cycle. The three factors in the expression for arc energy are current, voltage and time, the same as for the energy of any other part of an electric circuit. Therefore, if i, v and t represent

these three factors for a half cycle, then the arc energy equation can be given as

$$E_a = \int v.i.dt \dots \dots \dots (22)$$

and the total energy for N half cycles, as

$$E_N = \sum_0^N \left\{ \int v.i.dt \right\} \dots \dots \dots (23)$$

Of the quantities entailed in this equation, the current i can be calculated with fair accuracy. For the voltage v , it will be

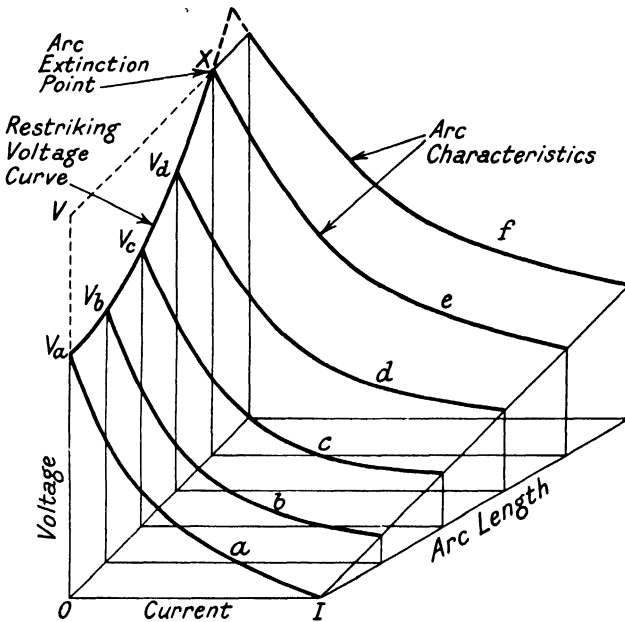

FIG. 95. VARIATION OF A.C. ARC CHARACTERISTICS WITH ARC LENGTHENING
Also shows ultimate stability point.

recalled that this is dependent on the value of the current. If the current is such as to effect ionic saturation, then the value of 50 volts per cm., as given by the Electrical Research Association, can be accepted as a fairly close estimate of the true value. The time factor in the arc energy expression is allied with the critical gap length, and thereby with the speed of opening.

Speed of Break. Now it has already been shown that the voltage drop across an a.c. arc when the current reaches zero is not of itself sufficient to restart the arc. A definite increase in voltage must be provided, and this restriking value becomes greater as the arc gap lengthens. As shown in Fig. 95, there is eventually reached a restriking value higher than the system recovery voltage is able to supply. It would therefore seem advantageous so to design the speed of opening of the breaker that this critical gap length will be reached in the smallest possible time. The objection is sometimes raised that this critical length is attained during a half cycle rather than at the end of one, and there is undoubtedly a greater probability that this will be so than otherwise. Thus, suppose the critical length of gap is reached just after the arc has restarted after zero. Then for all of the next half cycle, the arc will burn at a length greater than the critical length, and there will be a correspondingly greater amount of energy released. But, and here is where the speed comes in, the greater the velocity of the contacts, the greater will be the increase of arc length during the half cycle, and therefore the greater the energy in the arc. Furthermore, the shorter the time of total duration of the arc, the more important becomes the critical gap when reached just after a current zero point. Because the smaller the number of half cycles of arc duration, the larger percentage of this number does one half cycle become.

From this it would seem that there is a critical speed for the best performance. For example, let

L = critical length of gap.

V = velocity of contacts.

f = frequency, say 50 cycles per sec.

t = time to reach critical gap length at average velocity V ,
such that $L = Vt$ and $t = L/V$.

v = arc voltage.

i = current.

E_c = arc energy at critical gap length = $viLt$.

Then if the critical gap length is reached just after a zero current point, the additional arc energy involved for the ensuing half cycle equals vi multiplied by both the length of gap traversed in this half cycle, and by half the time of duration

of the half cycle. The increase in the length of the gap in the half cycle is $V/100$, and the duration of a half cycle $\frac{1}{100}$ sec. Therefore the energy expressed by this is

$$\frac{1}{2} \left(\frac{1}{100} \cdot \frac{V}{100} \right) vi = \frac{V}{2 \times 100^2} vi.$$

But, in addition, there is the arc of critical length, L , which has also endured for this same half cycle. This is represented by

$$\frac{1}{2} viL \times \frac{1}{100} = \frac{viL}{200}$$

Therefore the total additional energy released by the arc during this half cycle is

$$E_a = \left(\frac{V}{2 \times 100^2} + \frac{L}{2 \times 100} \right) vi$$

This is a minimum when $E_a = 0$, or, when

$$\frac{V}{2 \times 100^2} = - \frac{L}{2 \times 100}$$

from which $V = 100 L$. Or, the optimum speed is when the contact velocity equals a hundred times the length of the critical gap.

From this then it is to be appreciated that there is a critical speed of opening which will give the least display of arc energy, but it is a speed that is not common with circuit-breakers of a critical gap length of more than a few inches. For example, consider a circuit-breaker which has a critical gap length of 9 in. Then the critical speed is $\frac{9 \times 100}{12} = 75$ ft. per sec.; a speed difficult to obtain in practice.

In high voltage circuit-breakers the critical gap is necessarily large, on account of the system voltage, apart from any effect of voltage transients at recovery. Therefore, the critical speed, as determined above, becomes almost impossible of attainment. Even so, the higher the speed of opening of the high voltage circuit-breaker, the better will be the performance of the breaker. This is only logical, since the sooner the critical gap length is reached, even although this should not coincide with a zero current point as the critical speed ensures, the shorter will be the total duration of the arc, and thus the less the

energy liberated. It is wrong to suggest that the high speed is detrimental because it draws out too long an arc. Once the critical gap is reached, the arc can only maintain for one more half cycle, and, in the case of high voltage circuit-breakers where the critical gap is unavoidably long and may entail a number of half cycles, the addition of one more becomes of small account. The greatest advantage is to obtain the critical gap length in the shortest possible time; practical limitations will ensure that during the next half cycle the arc will not be drawn out too far.

Multiple Breaks in Series. This question of speed of opening in the high voltage circuit-breaker is affected considerably by the adoption of a number of breaks per phase in series, and it is advisable to consider the limitations to the number of breaks per phase. In the first place, if V is the cross bar speed and N the number of breaks per phase in series, the effective speed of opening is NV ft. per sec., and it would seem that the critical speed would be achieved when

$$NV = 100L \text{ or when } V = (100/N)L$$

But this is to assume that the critical gap L is the same for a long gap as it is for a series of shorter ones. This is not necessarily the case. If reference is made to equation (20) on page 138 for arc voltage

$$V_a = V_c + Kl\sqrt{i} + \beta l$$

it will be seen that the two last terms are dependent directly upon the arc length, whilst the first is for anode and cathode drop. Thus for N breaks, the anode and cathode drop becomes N times greater than for one break. In the second term, while l becomes l/N for N breaks, the current i remains unchanged. On the whole then, the voltage distribution across any one of a series of gaps will be different from that across a single gap of equivalent length. Therefore the critical gap length will be different.

The fact of the anode and cathode drops being increased is an advantage to multi-break, since the greater the proportion of the available voltage that is absorbed in these drops, the less will be available for restriking the arc. During high current values, the third term of the equation would lead to the supposition that the number of breaks was of no consequence. During the periods of current zero proximity, the second term of the equation, which for N breaks becomes $Kl\sqrt{i} \cdot N$, states

that the voltage is N times less than for one break, and again suggests that the number of breaks is of no consequence on the voltage across the N arcs as a whole. Therefore equation (20) can be rewritten for N breaks in series as

$$V_{a,N} = NV_c + Kl\sqrt{i} + \beta l \text{ for } N \text{ gaps} \quad . \quad . \quad . \quad (24)$$

From this it is to be observed that as the number of breaks increases, so is the voltage more and more absorbed in overcoming anode and cathode drop. Where then lies the limitation to the number of breaks in series? In the first place a certain

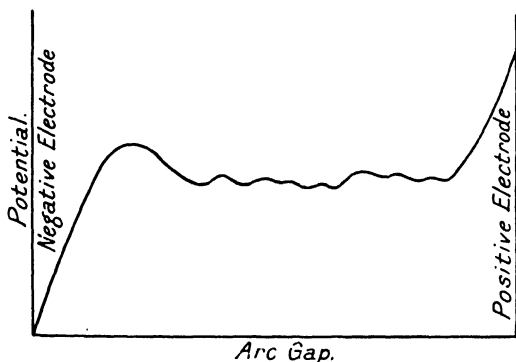

FIG. 96. POTENTIAL DISTRIBUTION BETWEEN THE ELECTRODES OF AN ELECTRIC ARC

indication has just been given of the difference in the voltage distribution between a long arc and a series of short arcs of the same total length. But, if reference is made to Fig. 90, which shows the voltage distribution across an arc gap, it will be observed that the anode and cathode drops give an acute voltage gradient near each electrode, whilst there is a comparatively even distribution in the middle. In the long arc the proportion of small gradient to steep gradient is much greater than in the short arc. But the question is not quite so simple even as this, since the gradient in the middle part of the arc is not a continuous function. It depends among other things on the pressure, temperature and composition of the intervening gases. An example curve of the type of potential distribution to be expected is given in Fig. 96.

In a series of short arcs, although the potential distribution curves for each will be generally the same as shown in Fig. 96,

they will not be exactly so. Also, it will be appreciated that while for the long arc there is but one cathode and anode "fall," as represented by *ab* and *cd* respectively in the figure, in the short arcs there will be as many of each as there are short arcs in series. It is true they will not be of the same magnitude, nor even in proportion. In addition to this, the voltage across each of the arcs in series will be controlled by the capacitance between the various arc gaps and between them and earth. This can be amply explained by considering the case of two arcs in series. Thus, suppose the two arc gaps to have each the same capacitance, and suppose the capacitance between the two arc gaps and earth to be four times that between each arc gap, so that the capacitances are in the proportion of one to four. It is then easy to prove that, in the case of a three-phase short circuit earthed, the voltage distribution across the arc gaps of the first phase to clear is 83.4 per cent across one gap and 16.6 per cent across the other. Thus one gap is doing more of the work than the other.

From the practical point of view in multiple-arcing there is the difficulty of arranging the various sets of contacts so that the arcs will not be able to merge into one when the breaker operates under heavy current conditions. Provided all points in the design are carefully considered, it would seem that there is an advantage in the multiple-arc breaker, and further, that the advantage is in direct proportion to the number of arcs in series.

Arc Energy (2). Returning to the question of arc energy, a value* has been assigned for the voltage per centimetre of arc length, whilst the current value can be determined from oscillograms or calculated from circuit constants. There remains to be found a value for *t*, the duration of the arc. From the above it will be appreciated to what extent this is allied to speed of opening, and number of breaks in series. But having determined these values and realizing that the energy figure is the summation of a series, the expression can be written for the mean value of arc energy, as

$$E = \frac{1}{2} V_a I_m t l_e \quad \dots \dots \dots (25)$$

where *E* is arc energy in watt seconds, V_a is arc voltage, I_m is r.m.s. value of arc current, and l_e is effective arc length in centimetres. This equation should be applied to each half cycle

* See page 143.

of the duration of the arc, or, if it is desired to make the calculation in one step, then the values V_a and I_m must represent the mean values of arc voltage and current throughout the whole period of arc duration. It may be preferable to base the calculation on contact bar speed, in which case the equation is written

$$E = \frac{1}{2} V_a I_m V_c t^2 \quad . \quad . \quad . \quad . \quad . \quad . \quad . \quad (26)$$

where V_c is the mean velocity of contact separation. If there are N breaks in series, it is to be appreciated that

$$V_c = NV_b$$

where V_b equals mean velocity of the contact bar.

It is the custom of some authorities to add to the above equation for the total energy liberated by the arc the energy absorbed at the contacts. This portion of the energy figure is represented by

$$2 v_c I_m t$$

where v_c represents the energy loss at the contacts due to heat conduction into the conductors and radiation. The final equation for arc energy thus becomes

$$E = \frac{1}{2} V_a I_m V_c t^2 + 2 v_c I_m t \quad . \quad . \quad . \quad . \quad . \quad . \quad . \quad (27)$$

This total energy, and the mean time during which it endures, is the correct physical interpretation of the breaking capacity of the circuit-breaker; although it is not the one conventionally adopted. This point will be further discussed later.

There is an expression given by Dr. Bauer for arc energy of the form

$$E = c V I t \quad . \quad . \quad . \quad . \quad . \quad . \quad . \quad (28)$$

in which V is the system voltage, I the current and c a switch constant. The constant c is said to vary between 0.07 and 0.2, and to depend upon the manner in which the voltage and current vary during the period of arcing. This expression is used extensively on the Continent, but is not accepted by the Electrical Research Association as being sufficiently accurate.

The Gas Bubble. When circuit-breaker contacts come together under oil, it is safe to assume that a film of oil adheres

to the contact surfaces despite the pressure that keeps the contacts together. When the contacts part as a result of the circuit-breaker opening under load, there is a tendency to form a vacuum or cavity between the surfaces. This is to be avoided if at all possible, since the cavity would not be a true vacuum but would be filled with oil vapour. The conductivity of such vapour would be much higher than that of oil, whilst its thermal capacity would be much less.

The ideal condition, then, is that the movement of the contacts on opening should disturb the oil as little as possible, so that the arc upon formation, is in the closest possible proximity with the oil. This is an advantage to multi-breaking, since at the commencement of arcing the quantity of oil close to the arcs increases in direct proportion to the number of arcs formed. From this it follows that the moving contacts should, as far as possible, be streamlined in the direction of opening. This has the double advantage in that it gives the least disturbance to the oil, and offers the least resistance to acceleration.

One must not confuse the theory of oil turbulence for arc extinction, as utilized by the various arc control devices, with the turbulence created by the parting of contact surfaces. The former is an advantage whilst the latter is not.

The temperature of the arc is dependent to some extent upon the material of the contacts. With carbon electrodes a temperature of arc root of $3\,500^{\circ}$ K. can be attained, and with copper electrodes a temperature of between $6\,000$ and $7\,000^{\circ}$ K. has been reached. The obvious effect of this temperature is to heat up and volatilize the adjacent oil. A certain heat absorption is required for this purpose, depending upon the specific heat and boiling point of the oil, and on the latent heat of the gases formed. The gases then increase in temperature and expand. The rate of gas formation and expansion is too slow to affect the rate of temperature rise to any great extent, with the result that the gases in the immediate neighbourhood of the arc are quickly raised to temperatures almost coincident with that of the arc itself.

Numerous experiments have been made to determine the nature of the gases formed by an arc in transformer oil. According to the findings of the Electrical Research Association, the constituents and their proportions are as given in Fig. 97. These values will vary according to the grade of oil used. Also, the curves are plotted to points, each of which is the

mean of a series of tests at a given current value. For instance, at 270 A. the acetylene content varied from 9.7 per cent to 26.0 per cent, and the hydrogen content from 65.9 per cent to 82.4 per cent. At 2 150 A. the variation is not so pronounced, the acetylene figures being from 17.7 per cent to 26.6 per cent,

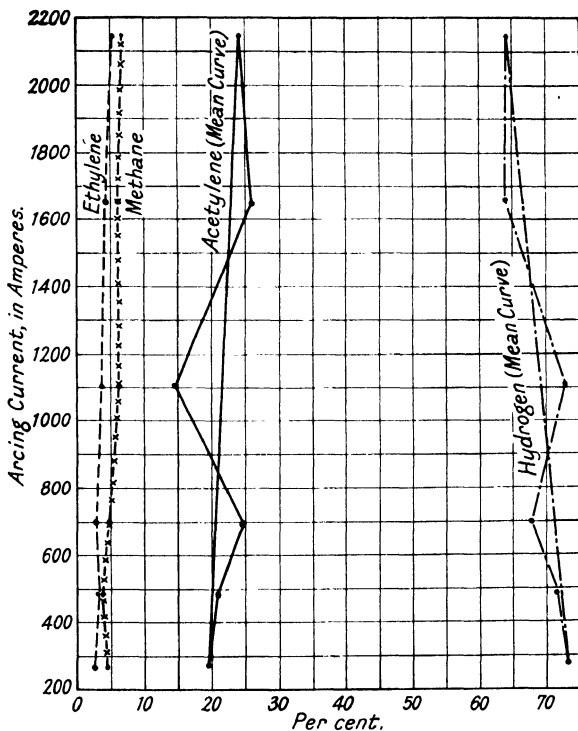

FIG. 97. CURVES SHOWING ANALYSIS OF OIL DISSOCIATED BY ARCING

and the hydrogen from 62.3 per cent to 71.7 per cent. From the mean of the curve there seems to be a slight tendency for the acetylene content to increase with increasing current, and for the hydrogen to decrease. On the whole, however, the actual values vary so much in the separate tests that no definite law can be said to exist on this point.

In the ideal case these gases will form a regular mass, the envelope of which will assume the shape of an egg. It will be appreciated that the lengthening of the arc will prevent this

gaseous envelope from assuming the truly spherical form, owing to the upward tendency of the hot gases and the slight lag in gas formation as the arc extends.

In those oil circuit-breakers in which the arc is formed in the body of the tank unhampered by any control device, the formation of the gas envelope is important in so far as it determines the impact shocks on the tank side and the rate of cooling of the arc. But where a control device is fitted, the arc chamber is of such limited dimensions that the natural shape of the gas envelope is quickly distorted by the irregular walls of the chamber. In such cases the shape of the gas bubble is of small consequence.

The more the gas bubble expands, the smaller becomes the rate of heat loss from the arc, since the gases intervening between the arc and the oil wall of the bubble have a smaller heat conductivity than has the oil.

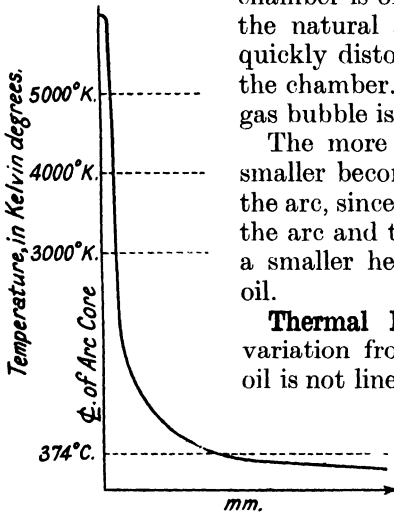

FIG. 98. VARIATION OF TEMPERATURE FROM CORE OF ARC TO OIL

Thermal Ionization. The temperature variation from the core of the arc to the oil is not linear, but follows an order somewhat as shown in Fig. 98. It

will be observed from this that the gradient is particularly steep from the core to the gas adjacent, and then more gradual through the gas to the oil. The maximum

temperature of an arc core is not definitely known, but it would seem to be somewhere in the neighbourhood of 7 000° K. At this temperature the gases formed from the oil become subject to dissociation and ionization.

This means that at a given temperature the gases will disintegrate, and the complex molecules will split up into simpler molecules. As the temperature is further increased the atoms become ionized. The temperature at which this thermal ionization takes place varies according to the nature of the gas.

It was Nernst who investigated the thermodynamics of chemical reactions, and on his work Saha deduced an equation for thermal ionization. In the first place it should be understood that all gases are subject to certain critical potentials.

Thus if hydrogen is submitted to an electric stress, at first of low value and then increasing, there will be no measurable current through the gas. As the potential is raised, a value is reached at which the free electrons in the gas have sufficient energy when striking the gas molecules to create radiations of short wavelength; which radiations, acting on the electrode, give rise to feeble currents. This is a critical potential and is known as the *resonance potential* for the gas in question. If the potential is further increased, the current increases steadily until another critical value is reached. This is when the electrons have acquired sufficient energy to ionize the gas molecules by impact, and is known as the *ionization potential* for the gas.

This ionization potential is of some importance in high-powered arcs, because of its different values in different gases and vapours. For instance, the ionization potential for molecular hydrogen is 15·9 volts, whilst that for copper is about 7·8 volts. In the alkali metals the ionization potential varies practically inversely as the atomic weight; thus for caesium it is 3·9 volts. The main importance of ionization in the gas bubble of the oil circuit-breaker is that it is a measure of the conductivity between the parting contacts, and the lower it can be kept the more quickly will the circuit be interrupted. It is of critical importance during the zero current pause of the a.c. system. The emission voltage for most metals being less than the ionization voltage for most gases means that, during the major portion of the half cycle, the current is nearly all emission current from the glowing electrodes, and very little ionization current. About the zero pauses, however, the conditions are reversed, and a new half cycle may easily be started by ionization currents.

From what has already been said, it will be understood that ionization is the result of the mobility of the ions, since it is from this, together with their mass, that they obtain their energy. Thus if m is the mass and V^2 the mean square of translational velocity, the kinetic energy of molecular agitation is

$$\epsilon_m = \frac{1}{2} m \overline{V^2} \quad \dots \quad (29)$$

The temperature of the gas is a measure of this velocity of agitation, while the ionization is measured by the molecular energy. Thus, if P is the pressure of a gas, Maxwell has shown that

$$P = \frac{1}{3} m N \overline{V^2}$$

where m is the mass, N Avagadro's number, and \bar{V}^2 the mean square of translational velocity. The gas law gives the expression

$$Pv = R\theta \quad . \quad . \quad . \quad . \quad . \quad . \quad . \quad . \quad (30)$$

where P is as above, v the volume, θ the absolute temperature and R the gas constant. From equation (30) is obtained

$$P = R\theta/v$$

whence

$$R\theta/v = \frac{1}{3} mN\bar{V}^2 \quad . \quad . \quad . \quad . \quad . \quad . \quad . \quad . \quad (31)$$

or $\bar{V}^2 = 3R\theta$, since $v = 1/mN$. Substituting this value of \bar{V}^2 in equation (29), the molecular energy is given by the expression

$$\epsilon_m = \frac{3}{2} mR\theta \quad . \quad . \quad . \quad . \quad . \quad . \quad . \quad . \quad (32)$$

Thus it is proved that thermal ionization is a measure of the velocity or mobility of the ions and the temperature of the gas.

Now ionization of a molecule, when it takes place, can be represented by $M \rightleftharpoons M^+ + e - u$; where M is the neutral molecule, M^+ the ionized molecule, e the electron, and u the heat of reaction per gramme molecule. And

$$u \propto \frac{3}{2} mR\theta \propto \frac{1}{2} mV^2$$

Saha has given the equation for thermal ionization thus

$$\text{Log}_{10}K = -\frac{u}{4.571\theta} + \sum n c_p \frac{\text{Log}_{10}\theta}{R} + \sum n C \quad . \quad . \quad (33)$$

u , θ , and R have the meanings given above; C and c are chemical constants. K is the proportion of molecules or atoms ionized and is equal to $(P^+ P^-)/P$; where P^+ is pressure due to positive ions, P^- pressure due to negative ions, and P that due to the neutral atoms.

Now u is expressed in gramme-calories, but it is more convenient to use the value in ionization potential. One gramme-calorie is equal to 4.18×10^7 ergs. Ionization voltage is the voltage through which an electron must fall to acquire sufficient energy to ionize the molecule on impact. The value of e , the electron charge, is 4.774×10^{-10} e.s.u., and one volt equals $\frac{1}{300}$ e.s.u. Therefore, the work done by a charge of 4.774×10^{-10} units falling through $\frac{1}{300}$ unit, or one volt, is $(4.774 \times 10^{-10})/300$ ergs, or, one ionization volt = 1.591×10^{-12}

ergs. The number of atoms in a gramme-atom, or molecules in a gramme-molecule, is 6.06×10^{23} , and as the ionization potential is per atom or molecule, the expression becomes

one gramme-calorie

$$= \frac{4.18 \times 10^7}{1.59 \times 10^{-10} \times 6.06 \times 10^{23}} = 4.35 \times 10^{-5} \text{ volts.}$$

Or, one ionization volt

$$= 23\,000 \text{ gramme-calories.}$$

The ionization of the gas is, of course, just another way of expressing its conductivity, so that the greater the ionization, the greater the conductivity. Apart from the electrical conductivity there is the thermal conductivity, and for oil circuit-breakers, the higher the thermal conductivity the better, since, the more rapidly the heat is borne away, the more rapid is the temperature fall in the arc, and the smaller is the ionization, and so the conductivity.

Kopeliowitsch has calculated for hydrogen the degree of dissociation against absolute temperature, and curves taken from his paper are reproduced in Fig. 99. Nos. 1, 2, 3 and 4 are for pressures of 0.1, 1.0, 10 and 100 kg. per sq. cm. respectively. From these curves it will also be observed that the temperature for 100 per cent dissociation varies with the pressure. With a pressure of 100 kg. per sq. cm. the temperature necessary to effect 100 per cent dissociation is of the order of $10\,000^\circ \text{K.}$ whilst with a pressure of 10 kg. per sq. cm. the temperature for 100 per cent dissociation is about $7\,000^\circ \text{K.}$ These temperatures may be higher than the arc is likely to reach, from which it would seem to follow that the major part of the conductivity of the arc flame is due to the ionization of the metal vapours and not to that of the gases. O. Mayr has also investigated this question and some of his curves are shown in Fig. 100. These show the dissociation of the different gases, and also the ionization for copper vapour. Thus for temperature between say $6\,000^\circ \text{K.}$ and $7\,000^\circ \text{K.}$ and at a pressure of 10 kg. per sq. cm. the hydrogen will be 100 per cent dissociated, and the copper about 9 per cent ionized. There will also be a small degree of ionization of the hydrogen atoms which, according to curve No. 2, Fig. 100, will be about 0.5 per cent.

Thus it is seen that the greater part of thermal ionization

of the arc path is that effected on the metal vapours. In addition to this thermal ionization there is the ionization due to the main arc stream described earlier.

An advantage of the high temperature is that atomic hydrogen has a better thermal conductivity than when it is in the molecular state. For instance, Langmuir has shown that at 6 000° K. the conductivity is 18.5 times better. This is because,

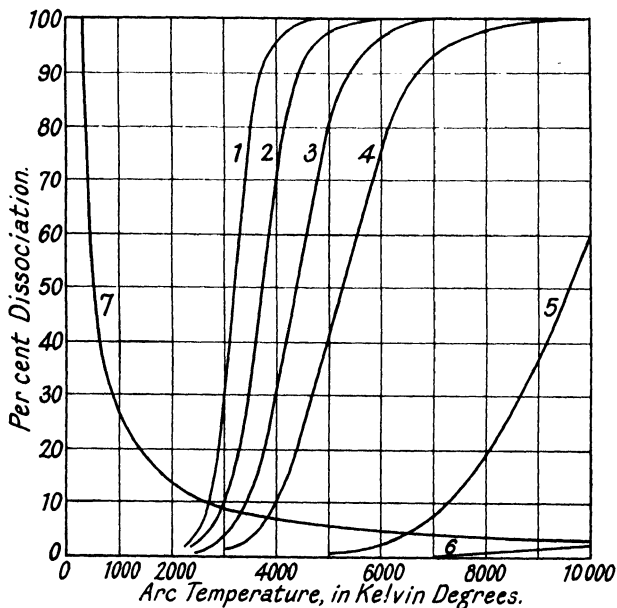

FIG. 99. DEGREE OF DISSOCIATION OF HYDROGEN AS A FUNCTION OF ABSOLUTE TEMPERATURE
(From paper by Dr. Kopeliowitsch)

owing to their lighter weight, hydrogen atoms diffuse more quickly. The diffusion of ions is not so rapid as is that of the neutral atoms, and the diffusion of the negative ions is somewhat greater than that of the positive. In all cases the diffusion is reduced as the pressure increases, which is only to be expected because the mean free path is then shorter. This diffusion serves two purposes. The general diffusion tends to lower the temperature of the gas bubble, and the ionic diffusion tends to lower the degree of ionization in the arc path.

There are two conditions, then, by which the arc will be

interrupted: one, that the rate of heat conduction from the arc shall be greater than the rate of heat generation by the arc, and the other that the rate of recombination shall be greater than the rate of ionization.

In his investigation of these questions Kopeliowitsch has given a formula for what he calls the increase in the strength of the gas gap. With the aid of this and calculations he has made for the rate of restriking voltage, he has plotted curves

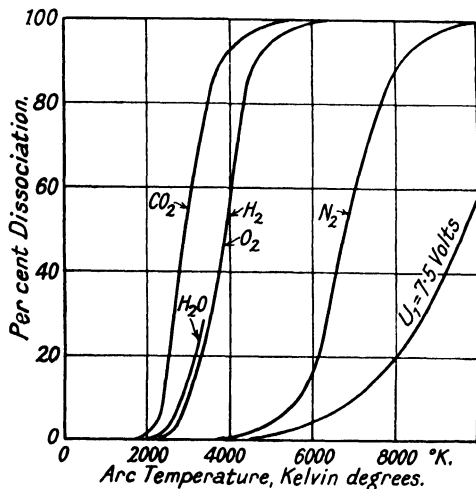

FIG. 100. RELATION BETWEEN ARC TEMPERATURE AND DISSOCIATION OF MEDIA
(From paper by Dr. O. Mayr)

shown in Fig. 101 for an example case. It is assumed that the circuit has a natural frequency of 3 000 cycles per sec., and the final quenching takes place at the third current zero. After the first current zero, the increased strength of the path is as shown by the curve 1a, and the restriking voltage by the curve 1. These two intersect at the point A after 42 microseconds; at which point the restriking voltage equals the breakdown voltage and restriking of the arc takes place. After the second current zero, there is a similar occurrence according to curves 2a and 2, and the arc again strikes at B in 100 microseconds. After the third current zero, the breakdown voltage of the path, as determined by the rate of ionization and recombination, builds up more rapidly than does the restriking voltage, and

the arc does not remake. Kopeliowitsch gives as the quenching condition

$$(V_b + \sqrt{2} \cdot E_0 \sin \phi)e^{-\alpha\tau} \cos(2\pi f_0 \tau + \pi) + \sqrt{2} \cdot E_0 \sin \phi < N[\epsilon_1 v t \tau F(vt_1 I_k P \tau) + \epsilon_0] \quad (34)$$

The symbols have the following meanings—

V_b = arc voltage, E_0 = generator voltage, ϕ = angle of lag, e = natural logs, τ = time of rupture in secs., f_0 = natural frequency of circuit, N = number of breaks in series, ϵ_1 =

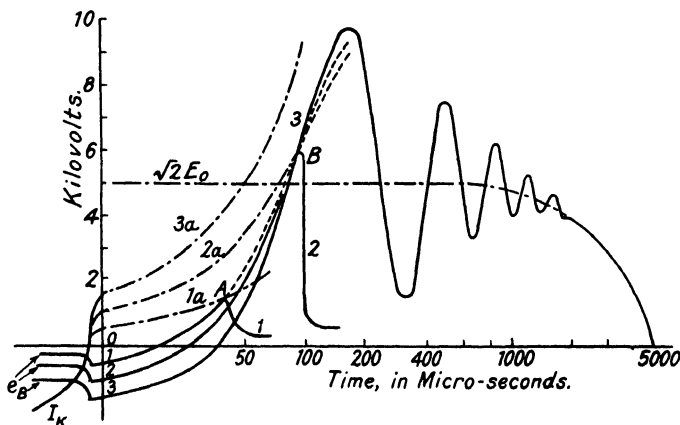

FIG. 101. SPARKING PHENOMENA

Curves 1, 2 and 3 represent restriking voltage. Curves 1a, 2a and 3a represent increase in gap strength. Points A and B are re-sparking points. e_b is arc voltage.

(From paper by Dr. Kopeliowitsch)

increase in strength of gas path per cm. per sec. in volts, v = speed of break in metres per sec., P = pressure in oil circuit-breaker, $F(vt_1 I_k P \tau)$ is an empirical function. ϵ_0 is the strength of the gas path at time $\tau = 0$.

While the principle of this method is undoubtedly right, the practical difficulty lies in determining the correct values for the factors in the empirical term.

Energy Balance. The Electrical Research Association is at present engaged in a scientific investigation of circuit-breaking phenomena, and to the work so far done Mr. C. E. R. Bruce has made a valuable contribution by calculating the distribution of energy liberated in the oil circuit-breaker. This has been given at some length in his paper in the *I.E.E. Journal*, No. 413.

A balance sheet is made out for a given case in which the total energy liberated in the breaker is balanced against the energy absorbed in breaking up the oil and the expansion of gases, etc. It is given that the energies absorbed comprise—

- 1. Contact energy.
- 2. Radiation.
- 3. Energy to heat the oil.
- 4. Energy to boil the oil.
- 5. Energy to break up the oil.
- 6. Energy to raise the gas to arc temperature.
- 7. Energy to expand the gas.
- 8. Energy to dissociate the hydrogen.

1. *Contact energy.* For this the formula

$$E_1 = 30 I_0 t \text{ joules} \quad (35)$$

is used; I_0 being the mean current and t the time of arc duration. The constant 30 is the voltage drop at the contacts as deduced by the Electrical Research Association. This deduction is made by calculating for the energy lost by the flow of heat from the arc root into the conductor.

2. *Loss due to radiation.* This has been determined by test, from which the value of 8 volts per cm. was determined. The formula for radiation loss is then

$$E_2 = 8 \times \frac{1}{2} l I_0 t \quad (36)$$

where l is the arc length in cm. This formula cannot be considered as final. No allowance is made for temperature or surface area.

3. *The energy to heat the oil.*

$$E_3 = M (t_1 - t_2) s \quad (37)$$

where M is the mass of oil in grammes, t_1 and t_2 are the temperature range, and s is the mean thermal capacity = 0.65 calories per gramme or 2.72 joules per gramme.

4. *The energy to boil the oil.*

$$E_4 = M \times \text{latent heat of oil} \quad (38)$$

Latent Heat = 217 joules per gramme approx.

5. *The energy to break up the oil.* From the tests made it has been determined that the oil splits up into approximately 86

per cent carbon and 14 per cent hydrogen, from which the mean molecular constitution for the oil is given as $C_{11}H_{33}$. The gross calorific value of the oil is given by the Electrical Research Association as 4.5×10^4 joules per gramme. To this must be added the energy in joules for heating and boiling the oil. Table X is reproduced from Mr. Bruce's paper, and in this is given the proportion per 1 000 cub. cm. of the various gases liberated.

TABLE X

Gas	Volume	Mass of H in Gases	Mass of C in Gases	Mass of Gas
Symbol	Cub. Cm.	G.	G.	G.
H ₂	690	0.0615	—	0.0615
C ₂ H ₂	230	0.0205	0.2460	0.2665
CH ₄	50	0.0089	0.0267	0.0356
C ₂ H ₄	30	0.0054	0.0324	0.0378
Total	1 000	0.0963	0.3051	0.4014

From this table it is seen that in the 1 000 cub. cm. of gases there is 0.0963 g. of hydrogen. As stated above, this quantity of hydrogen forms 14 per cent of the oil products. Therefore the quantity of oil to produce 1 000 cub. cm. of this gas is $(0.0963 \times 100)/14 = 0.688$ g. The mass of gas given by this amount of oil is, from the table, 0.4014 g. The difference between this value and the mass of oil, i.e. 0.287 g., is the quantity of carbon deposited, thus making a total carbon content of $0.287 + 0.3051 = 0.592$ g. The calorific value of the oil for 1 000 cub. cm. of gas is $0.688 \times (4.5 \times 10^4 + 1\,220) = 3.18 \times 10^4$ J., assuming 1 220 J. as an average value for the heating and boiling of the oil.

In the first place, consider the oil to be split up into H₂O and CO₂; then, allowing for the heats of formation of these, the chemical energy to break up 0.688 g. of oil for the formation of 1 000 cub. cm. of gas is

$$0.0963H_2 + 0.592C + \left(3.18 \times 10^4 - \frac{0.0963 \times 2.86 \times 10^5}{2} - \frac{0.592 \times 3.96 \times 10^5}{12} \right) \text{J.}$$

or, $0.0963H_2 + 0.592C - 1\,520$ J. 2.86×10^5 and 3.96×10^5 are the heats of formation of hydrogen and carbon respectively.

To this must be added the energy required to raise the aforementioned products to the oil boiling point. This will necessitate approximately another 690 J. Thus the value for breaking up the oil is now 2 210 J. To this a further addition must be made to allow for the thermodynamical energy. This represents the energy absorbed by the change in volume of the gas. Thus from the gas law $Pv = R\theta$, for each gramme-molecule increase in volume at constant pressure there will be an energy absorption of $R\theta$, where R is the gas constant and θ the absolute temperature. The value of R in joules is $1.997 \times 4.18 = 8.36$, and the absolute temperature at which the oil boils is 658 Kelvin degrees. Thus the energy for the 1 000 cub. cm. of gas is

$$\frac{0.0963}{2} \times 8.36 \times 658 = 266 \text{ J.}$$

Therefore the total energy for the breaking up of the oil is

$$E_5 = 2\,476 \text{ J. per 1\,000 cub. cm. of gas liberated.} \quad (39)$$

6. *To raise the gases to arc temperature.* The Electrical Research Association presume the temperature of the arc to be 2 800° K. and the mean thermal capacity of the gases as 2.63 J. per 1 000 cub. cm. Thus the energy in this case is

$$E_6 = 2.63 \times (2\,800 - 658) = 5\,640 \text{ J. per 1\,000 cub. cm. of gas liberated.}$$

In more general terms, this can be given as

$$E_6 = s(t - 658) \text{ J. per 1\,000 cub. cm.} \quad (40)$$

where s is the thermal capacity of the gas and t the arc temperature. The value of s varies according to the degree of acetylene present, and the figure of 2.63 is the mean for the temperature given. Fig. 102 shows how the value of s varies for different H_2C_2 contents and for different arc temperatures. This curve is reproduced from Mr. Bruce's paper.

7. *Expansion of the gases.* The formula for this is

$$E_7 = Rt_a \log_{\epsilon} (t_a/t_{bp}) \text{ joules per gramme molecule of gas } H_2 \quad (41)$$

where R is the gas constant, t_a the arc temperature and t_{bp} the boiling point temperature of the oil. For 1 000 cub. cm. of gas the value of $E_7 = 0.0481 Rt_a \log_{\epsilon} (t_a/t_{bp})$ obtained as

follows. The value of R per gramme molecule is 8.36 J. A gramme-molecule of hydrogen is 2 g. The mass of hydrogen in 1 000 cub. cm. of the gas is 0.0963 g., which equals $0.0963/2 = 0.0481$ gramme-molecule.

8. *Dissociation of the hydrogen.* For the degree of dissociation of the hydrogen into its atomic state, the Electrical Research

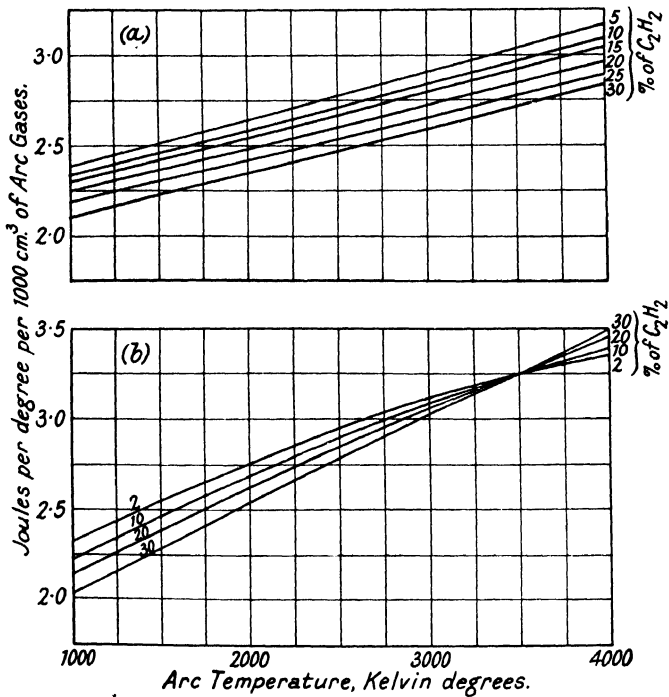

FIG. 102. VARIATION OF MEAN HEAT CAPACITY OF OIL PRODUCTS BETWEEN ARC TEMPERATURE AND OIL BOILING POINT, WITH ARC TEMPERATURE AND ACETYLENE CONTENT

(a) Assuming carbon and hydrogen present.
 (b) Assuming observed gases present.

(From paper by C. E. R. Bruce.—*I.E.E. Journal* No. 413, 1931)

Association use Langmuir's equation. A curve is given in Fig. 103 which is plotted from the values given in Langmuir's paper. For the energy to produce such dissociation the equation used is

$$H = 406\,000 + 14.6\theta - 0.00188\theta^2 \text{ joules per gramme-molecule}$$

where θ is the absolute temperature. Therefore if x is the degree of dissociation effected on m g. of hydrogen, the energy involved is

$$E_s = xmH/2 J. \quad (42)$$

The value of x is given in Fig. 103 for a pressure of one atmosphere.

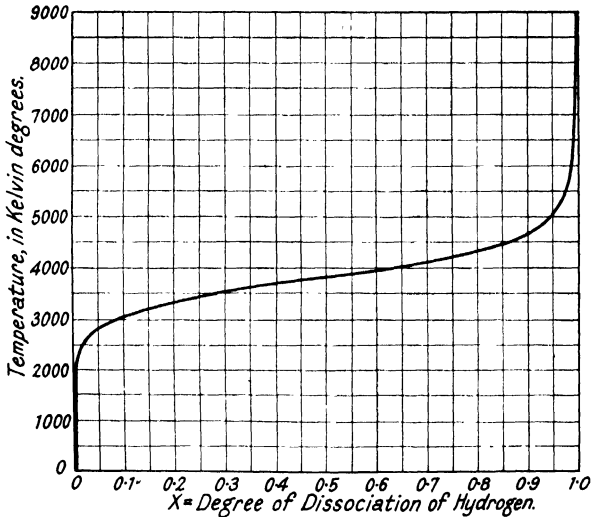

FIG. 103. DEGREE OF DISSOCIATION OF HYDROGEN INTO ATOMS AT ONE ATMOSPHERE PRESSURE

Let N = number of hydrogen molecules.
 " n = " " atoms formed by dissociation.
 " then $x = n/N$.

(Plotted from Langmuir's values)

The summation of the values E_1 to E_8 inclusive, will represent the total energy absorbed from the arc, and must therefore be equal in magnitude to the energy of the arc.

Hence, the energy balance is given by the equation

$$E_1 + E_2 + \dots + E_8 = \frac{1}{2} V_a I_m V_c t^2 + 2v_c I_m t. \quad (43)$$

The right hand side of the equation is the expression for arc energy as given by equation (27). This value can, however, be obtained from an oscillogram which shows the current and voltage, or total energy input into the circuit. In order to give some idea of the relative values of the various energy losses, the following is a very approximate proportion in which

the different values of E_1 to E_8 may be expected to be found: $E_1 = 17.5$ per cent; $E_2 = 11.5$ per cent; $E_3 = 4.3$ per cent; $E_4 = 1.0$ per cent; $E_5 = 15.7$ per cent; $E_6 = 34$ per cent; $E_7 = 9.7$ per cent; $E_8 = 6.3$ per cent.

Gas Volume and Pressure. The volume of gas produced per kW.-sec. of arc energy has been the subject of investigation by many eminent workers. Bruce gives 70 cub. cm. per kW.-sec. of arc energy; Muller gives 100 cub. cm. per kW.-sec. Zelessky, 60 cub. cm. per kW.-sec. and Bauer, 46.5 cub. cm. per kW.-sec. The figure of 60 cub. cm. per kW.-sec. may be accepted as being the nearest to the correct value for n.t.p.; i.e. 25° C. and 760 mm. The amount of gas liberated will depend on circumstances. The closer the oil wall is kept to the arc surface by any condition or device, the more gas will be produced per kW.-sec. It is possible at very high current values that this value of 60 cub. cm. will be increased, but there is no experimental data available on the point. For low currents, say of the order of 300 or 400 A., the value will be approximately 35 cub. cm. per kW.-sec.

The uncertainty that attaches to the correct determination of the volume of gases evolved for a given arc energy makes it futile to go to any great mathematical accuracy in the calculation of the forces which result from this evolution of gas. When an arc control device is fitted, the confined space of the arc chamber limits the expansion of the gas bubble, and higher gas pressures and greater gas volumes per kW.-sec. ensue. On the other hand the first impact from these greater forces consequent on the higher pressures is exerted upon the walls of the control device, and not on the tank.

In an open type breaker then, the gas evolution may be from 35 to 70 cub. cm. per kW.-sec. whilst in an enclosed arc chamber of such devices as explosion pots, etc., where the internal pressure may reach over 300 lb. per sq. in., the gas produced may be over 150 cub. cm. per kW.-sec. measured at n.t.p. From the latter values, the resulting stresses on the arc chamber may be calculated, and from the former, those on the tank.

Head of Oil. In the case of the open breaker, there is the head of oil to be considered. This can be determined with quite sufficient accuracy by the following method. The breaker will have a maximum kVA breaking capacity, and from this there will be a corresponding maximum arc energy. This arc energy will produce a given volume of gas which may be estimated

from what has been given above. The time factor in the production of this volume of gas will be the same as the time factor in the arc energy expression, which suppose is equal to t . The work done by the volume of gas during expansion in time t will be equal to the mean pressure times the volumetric expansion. The latter will be equal to the actual volume at end of time t , since, at time $t = 0$, the volume is nil. The expansion will be adiabatic rather than isothermal. The gas bubble will have a natural tendency to rise, but the lower surface of the

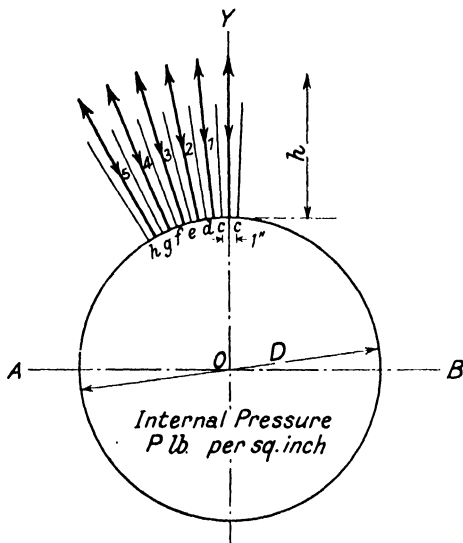

FIG. 104. GAS BUBBLE AND INTERNAL PRESSURE P PER UNIT AREA

bubble will be forced downwards by the moving contact when this latter opens downwards, as it mostly does. This movement of the lower surface of the bubble is not a mechanical effect, but is due to the approaching arc continually volatilizing the oil surface as it comes into contact with it. The position of the lower oil surface of the bubble in effect retreats before the drawing out of the arc. These two opposing movements, to rise and to be drawn down, help this expansion of the bubble, and maintain its centre almost stationary in relation to the fixed contact.

Now consider some instant at which the bubble is of a given diameter D and internal pressure P , and refer to Fig. 104, which

shows a graphical method whereby it is possible to obtain an approximate determination of the forces acting on, and movement of the oil above, the gas bubble. All forces acting below the plane *A-B* are ignored as regards their effect on the upper portion of the oil. Except for the small fluid compressibility

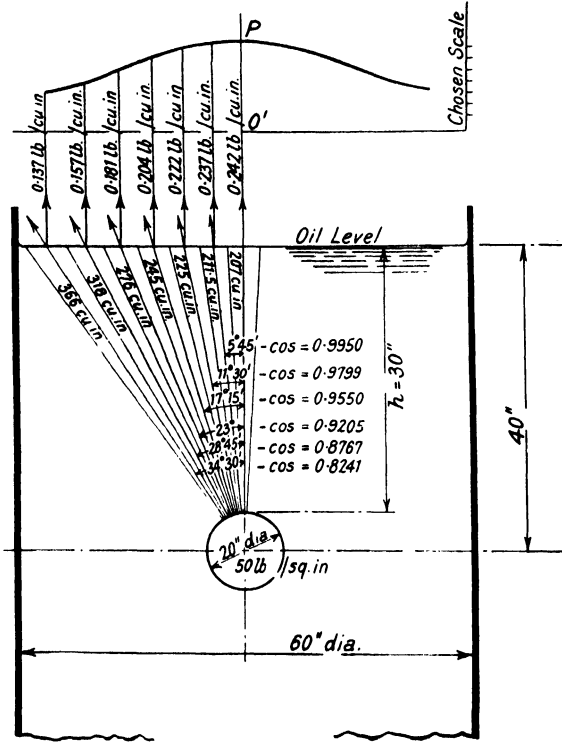

FIG. 105. GRAPHICAL METHOD OF DETERMINING NATURE OF OIL SURFACE DISTURBANCE
Chimney effect not apparent.

these force effects are negligible. Of the oil above *A-B* consider that volume that rests on a square base of side *c-c*, and let *c-c* be unity so that the base area is unity. The pressure on this base will be *P* lb., since *P* is the chosen value for the internal pressure per unit area. The volume of oil being acted on by the force of *P* lb. will be the volume of the frustum of an inverted pyramid on square base of side *c-c* and height *h*. (See Figs. 104, 105 and 106.) Let *V* equal this volume. The force *P* thus

acts on volume V along line OY . Draw line $O'P$ to represent the magnitude of this force divided by volume V , to some suitable scale. Then $O'P$ will represent the force per unit volume and will be a true vector for the force concerned. Let the remainder of the bubble hemisphere be divided into similar

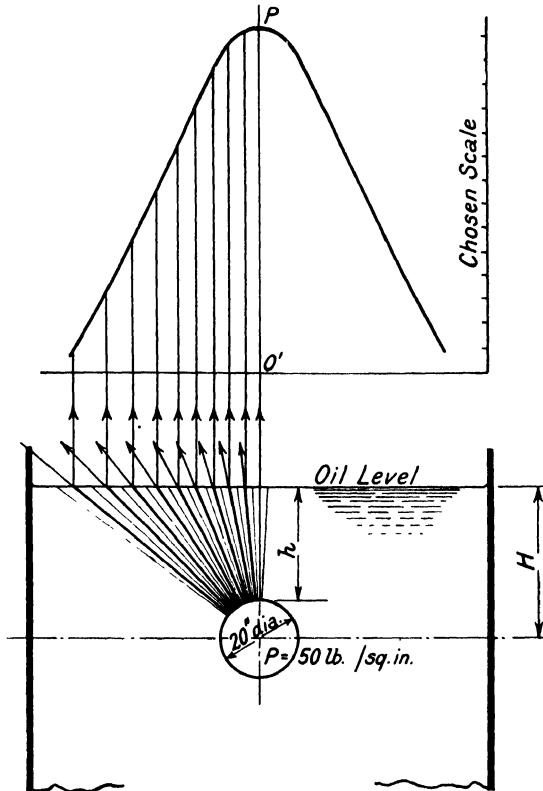

FIG. 106. OIL SURFACE DISTURBANCE WITH PRONOUNCED CHIMNEY EFFECT

units of area such as those given by sides $c-d$, $d-e$, etc., in the figure. The same force P will act on each of these, but the mass or volume will be different, and so also will be the direction of the force vector. Therefore, to obtain the force per unit volume, the force P will be divided by values V_1 , V_2 , etc. Having obtained the force per unit volume for each inverted pyramid of oil, resolve this force from its direction along the axis

of the pyramid into its component vertical to the surface of the oil. If this is done for each one of the oil columns chosen, a series of vertical vectors will be obtained, and these will represent to scale the relative upward forces acting on the oil from the pressure P in the bubble beneath. From the shape of the envelope of these vectors, the extent of the chimney effect will be obvious. In Fig. 105 there is no chimney effect and the head of oil may therefore be considered adequate, that is provided the pressure P is that which results from breaking the maximum kVA. for which the breaker is rated. Fig. 106 gives an example in which the head of oil is not sufficient and chimney effect is pronounced.

To take an actual case, suppose a breaker has a capacity of 100 000 kVA. at 33 000 volts. The maximum current in the arc will be 1 750 A. Suppose interruption is complete in five half cycles, then the duration of the arc is 0.05 sec. at 50 periods. Suppose the speed of opening is 5 ft. per sec. (average), then the length of the arc is $5 \times 0.05 = 0.25$ ft., which equals 5.1 cm. Therefore the arc voltage is $5.1 \times 50 = 255$ V., and the arc energy = $\frac{1}{2} \times 1750 \times 255 \times 0.05 = 11\ 150$ W.-sec. = 11.15 kW.-sec. Take the figure of 45 cub. cm. per kW.-sec. as the rate at which the gas is liberated, then the total quantity of gas liberated in the 0.05 sec. is $45 \times 11.15 = 500$ cub. cm., which is 30.5 cub. in. But this is the volume at n.t.p. It is necessary to calculate the volume at the temperature of the arc. Assume the arc temperature to be $3\ 500^\circ$ K., and the normal temperature at 288° K. Therefore from the law $V_i/V_i' = \theta/\theta'$ the volume at the arc temperature is

$$\frac{30.5 \times 3\ 500}{288} = 370 \text{ cub. in.}$$

This volume of gas is compressed into the bubble, and if we consider the instant when the bubble diameter is 4 in., the compressed volume of the liberated gas will be $4/3\pi\ 2^3 = 33.4$ cub. in. Therefore the internal pressure at this instant will be

$$\frac{370 \times 14.7}{33.4} = 163 \text{ lb. per sq. in.}$$

From this pressure the forces acting on the oil can be calculated and plotted graphically in the manner described above. The forces shown in Figs. 105 and 106 are not the total forces acting on the oil, but the forces per unit volume, and are given in

this manner to obtain the relative values in order to determine whether chimney effect is likely to occur. When the total forces are to be calculated, due allowance must be made for the opposing pressure from the compression of the air cushion. The effect of the air cushion is not nearly so important as it is generally made out to be. On light load-breaking, the oil surface is little disturbed and the air cushion effect is hardly called into action. On the heaviest loads the internal pressures are so high that the air is quickly shot out of the vents and the oil flung *en masse* against the top cover of the breaker, and in many cases follows the air through the vent. In general if the air volume is 8 to 10 per cent of the oil volume above the contacts, it is ample. When an arc control device is fitted an even smaller air volume will suffice.

Tank Pressure. A lot has been written by various authorities on the question of tank pressures, and all have based their calculations upon the volume of gas produced, arc energy, etc. This is all very well when it is required in connection with the head of oil and so on, but when, as is often the case, it is required in order to check the possibility of the tank bursting, then it is quite another matter. The most important factor in tank stress is that due to the restriking of the arc after zero. Sir J. J. Thomson has shown that when a spark passes between any two electrodes there is an extremely high pressure developed within the spark. It is created with the rapidity of the spark and spreads out as a pressure wave of steep front. Thus whatever obstacle it strikes receives an impact force of magnitude varying inversely as the distance of the object from the centre of the spark. There is, however, one difficulty at least in obtaining an accurate determination of this pressure, and that is the difficulty of estimating the sectional area of the arc. But to introduce this viewpoint by example and thus give an idea of the value of impact forces arising from this cause, the following approximate calculation is made on the case chosen for the example given above. Thus, to calculate the value of the impact force from the striking of the arc in the first half cycle of the short circuit, the mean current during this half cycle is, from the previous example, 1 750 amperes. The duration of the arc for the half cycle is, at 50 periods, 0.01 sec. Therefore the discharge is $1\,750 \times 0.01 = 17.5$ C. The length of the arc at the end of the half cycle will be, at 5 ft. per sec. opening speed, $5 \times 0.01 = 0.05$ ft. = 1.53 cm. Therefore, taking 50

170 OUTDOOR HIGH VOLTAGE SWITCHGEAR

as the average for voltage per cm. of the arc, the mean voltage across the arc will be

$$\frac{50 \times 1.53}{2} = 38 \text{ V.}$$

The energy of discharge is then $\frac{1}{2} \times 38 \times 17.5 \times 10^7 = 3.3 \times 10^9$ ergs; the value of 10^7 being a constant to bring the value to C.G.S. units. Now comes the uncertainty in the calculation. Assume the section of the arc as half a square centimetre. Then the mean volume of the arc for the half cycle is

$$\frac{0.5 \times 1.53}{2} = 0.38 \text{ cub. cm.}$$

Now the energy in a cubic centimetre of gas at n.t.p. is 15.2×10^5 ergs. Therefore the pressure from the discharge is given as

$$\frac{3.3 \times 10^9}{15.2 \times 10^5 \times 0.38} = 5750 \text{ atmosphere.}$$

which equals $14.7 \times 5750 = 84500$ lb. per sq. in.

This pressure varies inversely as the square of the distance from the centre of the arc. Therefore, if the tank side is 10 in. from the arc centre, the impact pressure on the tank side from the above is

$$\frac{84500 \times 0.8^2}{(10 \times 2.54)^2} = 83.5 \text{ lb. per sq. in.}$$

(0.8 is the arc diameter in cm. from the assumed sectional area of 0.5 sq. cm.). This impact load is in addition to the more steady pressure which occurs from the gas in the arc bubble. Thus it is observed that when the arc strikes after every current zero there is an impact stress impressed on all objects adjacent; so that for the five half cycles duration of arc in the case cited above there are five hammer blows of increasing severity given to the tank, etc. It is probable that many cases of tank bursting are due to this effect, and not to an explosion of the gases, as is more often believed.

In the scientifically designed circuit-breakers the calculation for tank stresses is an involved business, but as a general rule it can be given that, for the impact pressures, the tank loading may be at least four times the normal stress. Thus a tank that will satisfactorily withstand a steady pressure of 50 lb. per sq.

in. will be strong enough to withstand an impact loading of 200 lb. per sq. in.

BIBLIOGRAPHY

- H. Ayrton, *The Electric Arc*, London, 1902.
 B. Bauer, Zurich, 1915.
 J. Biermauns, *A.S.E. Bulletin*, No. 22, 1932.
 C. E. R. Bruce, *J.I.E.E.*, No. 418.
 J. A. Crowther, *Ions, Electrons and Ionizing Radiations*.
 E. R. A., *J.I.E.E.*, No. 389, Vol. 67.
 Hulme-Rothery, *The Metallic State*.
 F. Kesselring, *A.S.E. Bulletin*, No. 23, 1932.
 J. Kopeliowitsch, *A.S.E. Bulletin*, No. 22, 1932.
 I. Langmuir, *G.E. Rev.*, Vol. 29, 1926.
 O. Mayr, *A.S.E. Bulletin*, No. 23, 1932.
 James Clerk Maxwell, *Theory of Heat*.
 A. L. Muller, *Archiv fur Elektrotechnik*, Vol. 25, 1930.
 S. D. Norberg, *Properties of the Electric Arc*, Stockholm, 1925.
 Ornstein and Vermeulen, *Z. f. Ph.*, Vol. 70, 1931.
 H. Pearce and T. T. Evans, *J.I.E.E.*, Vol. 68, 1932.
 J. Slepian, *Trans. A.I.E.E.*, Vol. 26, 1927.
 C. P. Steinmetz, *Trans. A.I.E.E.*, Vol. 25, 1906.
 Sir J. J. Thomson and G. P. Thomson, *Conduction of Electricity Through Gases*.
 E. B. Wedmore, W. B. Whitney and C. E. R. Bruce, *J.I.E.E.*, Vol. 65, 1927; *J.I.E.E.*, Vol. 67, 1929.
 A. M. Zalessky, *Elektrichestro*, Jan., 1931.

CHAPTER VIII

RESTRIKING VOLTAGE AND BREAKING CAPACITY

ON page 141 it is asserted that the minimum voltage necessary to restart the arc after zero is that represented by OA in Fig. 94. Obviously the system must supply this voltage; yet during the period of arcing the system voltage is reduced to that required for the maintenance of the arc only, which at the approach of zero current becomes equal to OC in Fig. 94. How then is the voltage of the system raised from OC to OA to effect the re-striking? It is necessary to consider the circuit as a whole before this query can be answered.

During the period of arcing the circuit consists of the arc, the cables, machines, transformers, etc.; all of which for a given circuit and for currents of given sequence can finally be represented by the three parameters, resistance, inductance and capacitance. The resistance may be considered constant except for the arc; so also may the capacitance be considered constant, but the inductance is by no means so. Because inductance is a function of the magnetic circuit, change in current value will tend to alter the values in the magnetic circuit of machines and transformers, so that the inductance of the circuit is no longer the same. Thus an important factor controlling restriking voltage is the type of machine or machines supplying the circuit. It is impossible in this work to go closely into the characteristics of electrical rotating machinery, yet it is necessary to touch briefly on the subject in order to direct attention to the effect of such machinery on this question of restriking voltage.

In all kinds of rotating machinery there are conductors linked with magnetic fields, and the relative movements of these fields and conductors are naturally all important. Furthermore, the effect of the relationship between field and conductor will be different for different types of machines. Thus the effect of short-circuit will differ according to whether the generator is a turbo-alternator, salient pole machine, waterwheel alternator, etc. Again, for a given type of machine, there will be variation dependent upon whether armortisseur windings are or are not fitted. Still further, when there is a difference

between direct reactance and quadrature reactance of the machines, the effects will be governed by the position of the rotor with reference to the stator at the instant at which short-circuit occurs. From the above few facts alone, it will be appreciated that the problem is very extensive. Sufficient has already been said to indicate that before anything approaching accuracy in the determination of restriking voltage and breaking capacity can be achieved, it is desirable to know the characteristics of the rotating machines connected to the system.

When a circuit is closed it is well known that the time taken for the current to reach its steady value is dependent upon the proportions of resistance, inductance, and capacitance in the circuit. Exactly the same applies to the voltage. If resistance alone were present the steady value would be obtained immediately, but the presence of inductance and capacitance causes the current or voltage either first to overshoot the mark and then settle down to the steady value in a time dependent on the proportion of resistance inductance and capacitance, or else to reach the steady value in an exponential manner. All this is expressed mathematically by the standard equation

$$Ri + L \frac{di}{dt} + \frac{1}{C} \int idt = E \quad . \quad . \quad . \quad . \quad . \quad (44)$$

In a treatise on mathematics the proof will be found that in the above equation, if $R > \sqrt{4L/C}$, the value of i will vary exponentially. This means that with certain values of R , L and C the current will grow from zero to its steady value in an exponential manner. The voltage will grow similarly when the circuit is opened after short-circuit. It is also proved that if $R < \sqrt{4L/C}$, the current will assume an oscillatory character; which means that it will first overshoot the mark in the positive sense, then rapidly diminish and overshoot it in the negative sense, and so on; each successive positive and negative peak value diminishing in geometric progression until the steady value is reached. Again, so also will the voltage vary when a circuit of such values of R , L and C is opened after short-circuit.

In Fig. 107 there is given a curve showing the growth of voltage or current for the condition $R > \sqrt{4L/C}$. This curve can be represented by the equation

$$e = E (1 - \varepsilon^{-t/k}) \quad . \quad . \quad . \quad . \quad . \quad . \quad (45)$$

which is a logarithmic function; in that the value of the ordinate at any instant is proportional to the rate of growth of the ordinate at that instant.

From the above equation it is not difficult to prove that $E - e = K (de/dt) = Ee^{-t/k}$; where E is the maximum value of the voltage, e the value at time t , and K a constant equal to L/R : which is known as the *time constant* of the circuit.

Thus, if the time constant of the whole circuit were known, the value of the voltage at any instant could be ascertained. Unfortunately the time constant of a circuit varies according

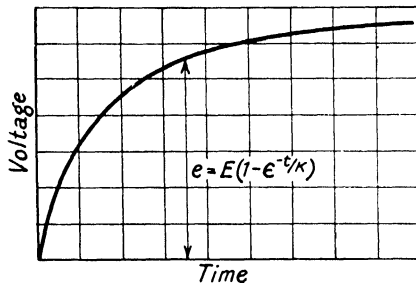

FIG. 107. GRAPH SHOWING GROWTH OF VOLTAGE FOR CONDITION

$$R > \sqrt{\frac{4L}{C}}$$

A similar one applies for current growth.

to the value of L , since $K = L/R$ and L varies as determined by the machine characteristics.

Consider a circuit in which resistance predominates. The closing of this circuit would result in the current rising sharply to a steady value, and, because reactance is negligible, the voltage would be in step with the current and would therefore also rise from approximately zero value. If, on the other hand, the circuit were nearly all reactance, the voltage wave would be in quadrature, and therefore, when the circuit was closed, the current would attain a value 90° different in phase from that of the voltage. Conversely, when the current in a resistance circuit is interrupted at its zero value, the voltage across the contacts will appear at a value nearly zero. But when the current in a reactive circuit is interrupted at its zero value, the voltage across the contacts will tend to appear at its maximum value. For circuits of intermediate values of resistance and reactance, intermediate values of restriking voltage will occur.

and therefore the restriking voltage. In the case of overhead transmission lines, the relative value of L/C is generally such that the resulting voltage wave is oscillatory and of high frequency. Furthermore, from points of discontinuity or open ends, partial or complete reflection occurs.

With circuit-breakers operating close to generating machinery the question of restriking voltage is very complex. It is necessary to seek the aid of symmetrical components, which is done in the following example.

Consider a three-phase short-circuit to earth, as shown

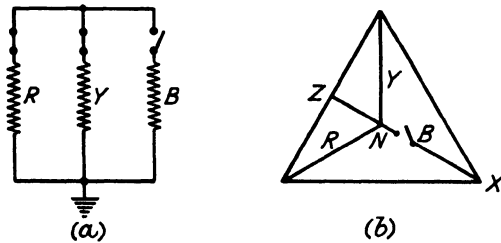

FIG. 109. THREE-PHASE SHORT CIRCUIT TO EARTH
 (a) Diagram showing blue phase to open first.
 (b) Vector diagram for above.

diagrammatically in Fig. 109. Let e_a , etc., equal the phase voltages; i_a , etc., the phase currents.

Let e_a^+ , e_a^- , e_0 equal the positive, negative and zero phase sequence components respectively. Then

$$\left. \begin{aligned} e_b &= e_b^+ + e_b^- + e_0 = 0 \\ e_c &= e_c^+ + e_c^- + e_0 = 0 \end{aligned} \right\} \dots \dots \dots (48)$$

since the phases b and c are short-circuited.

Now $i_b^+ = i_c^+$ and $i_b^- = i_c^-$

Also $Z_b^+ = Z_c^+$ and $Z_b^- = Z_c^-$, where the Z 's are the impedance components. Therefore

$$\left. \begin{aligned} e_b &= i^+ Z^+ + i^- Z^- + i_0 Z_0 = 0 \\ e_c &= i^+ Z^+ + i^- Z^- + i_0 Z_0 = 0 \end{aligned} \right\} \dots \dots \dots (49)$$

Assume the current between the terminals as unity, such that

$$i_a = i^+ + i^- + i_0 = 1 \dots \dots \dots$$

Then from equations (48) and (49) it can be deduced that

$$\left. \begin{aligned} i^+ &= \frac{Z-Z_0}{Z^+Z^- + Z-Z_0 + Z_0Z^+} \\ i^- &= \frac{Z+Z_0}{Z^+Z^- + Z-Z_0 + Z_0Z^+} \\ i_0 &= \frac{Z+Z^-}{Z^+Z^- + Z-Z_0 + Z_0Z^+} \end{aligned} \right\} \dots \dots \dots (50)$$

Now e_a will also equal $i^+Z^+ + i^-Z^- + i_0Z_0$, and the voltage e_a is the voltage across the terminals, i.e. is the restriking voltage. By substituting in the equation for e_a , the values for i^+ , i^- and i_0 given in equation (50), e_a can be written

$$e_a = \frac{3Z^+Z-Z_0}{Z^+Z^- + Z-Z_0 + Z_0Z^+} \dots \dots \dots (51)$$

And this equals the value of Z for the system, because the current is presumed unity.

Let E equal the phase-to-neutral voltage before short-circuit, then

$$i = E/Z^+$$

Therefore,

$$e_a \text{ (or restriking voltage) equals } iZ = EZ/Z^+ \dots \dots \dots (52)$$

Substituting the value of Z as given in equation (51)

$$\begin{aligned} \text{The restriking voltage } e_a &= \frac{3EZ^+Z-Z_0}{(Z^+Z^- + Z-Z_0 + Z_0Z^+)Z^+} \\ &= \frac{3EZ-Z_0}{Z^+Z^- + Z-Z_0 + Z_0Z^+} \dots \dots \dots (53) \end{aligned}$$

There is a special case which is generally given; that is, when the impedance of the network is so much greater than that of the rotating machinery that Z^+ can be taken as equal to Z^- ; also, that the fault is unearthed, or the neutral insulated, such that Z_0 becomes infinitely great and can be ignored. In this case equation (53) reduces to

$$3EZ/2Z = 1.5 E \dots \dots \dots (54)$$

There is another and more simple method by which may be solved the special case of a three-phase short-circuit on an

un-earthed system, or vice versa. Let Fig. 109 (a) represent the diagram of the circuit in question, and Fig. 109 (b) the corresponding vectors. Then, if the first phase to open is the blue phase, it is easy to see that the voltage across this break is the phase voltage of the blue phase plus the vectorial sum of the *R* and *Y* phase voltages. Or, if *E* is the phase voltage of the system, then, from the figures, the voltage across the first phase to clear is $XN + NZ$. And, as NZ is half XN , then $XN + NZ$ becomes equal to $1.5 XN$, which is equal to $1.5 E$.

When the breaker is in service near to the generating plant so that the positive and negative sequence reactances are not the same, the equation (53) must be used for the restriking voltage. Here, however, lies a difficulty in how to determine the value to assign to the negative phase sequence reactance for the machine.

Because the short-circuit is at or near the machine terminals, the load will be reactive and, assuming the earth impedance is at least very high, the restriking volts will be in quadrature with the current. Therefore, when current is interrupted at a zero value, the voltage will be 90° leading. Now the maximum voltage is generated in the machine windings when the armature coils are linking the quadrature field. Therefore the reactance at this instant is the quadrature sub-transient reactance. Thus the equation for the restriking voltage may be written

$$e = K_1 x_q'' i \quad . \quad . \quad . \quad . \quad . \quad . \quad . \quad . \quad (55)$$

where x_q'' is the quadrature sub-transient reactance. When the short-circuit current is at a maximum, i.e. sub-transient current, the voltage will be zero, and, for zero voltage, the machine pole paths are direct. Therefore the machine reactance at this instant is the direct sub-transient reactance.

$$\text{or } i'' = \frac{E}{x_d''} \quad . \quad . \quad . \quad . \quad . \quad . \quad . \quad . \quad (56)$$

where i'' is the sub-transient current, *E* the phase voltage and x_d'' the direct sub-transient reactance.

By superimposing the two equations above there is obtained for the restriking voltage

$$e = K_1 E \frac{i}{i''} \frac{x_q''}{x_d''} \quad . \quad . \quad . \quad . \quad . \quad . \quad . \quad . \quad (57)$$

Messrs. Park and Skeats in their paper on Circuit-breaker Recovery Voltages give the above equation as

$$e = K_q EK_\delta K_q \dots \dots \dots (58)$$

and assign to the various constants the values below—

- Constant K_q . . . depends on earth connection and
 - equals 1.0 for line-to-earth short-circuit ;
 - equals 1.73 for line-to-line short-circuit or for first phase to clear of two line-to-earth short-circuit on an impedance earthed or insulated system,
 - equals $\frac{3x_0}{S_q'' + 2x_0}$ for three-phase short-circuit
 - equals 1.5 for three-phase insulated short circuit on an earthed system, or for three-phase earthed short-circuit on insulated system.

Constant K_δ . . . equals $\frac{i}{i'}$ for all short-circuit

Constant K_q . . . equals 1.0 for all single-phase short-circuits and two line-to-earth short-circuit
 equals S_q''/S_d'' for all three-phase short-circuit.

S_q'' and S_d'' equal the summation of the different values of x_q'' and x_d'' in the circuit.

Messrs. Park and Skeats give the following values for the constant K_q for the different type machines—

TABLE XI
 QUADRATURE REACTANCE FACTORS

Types of Machine	$\frac{x_q''}{x_d''}$
Turbo-alternators—	
(a) Laminated rotor	2.5
(b) Solid rotor	1.4
Salient-pole machines—	
(a) Without amortisseur	2.3
(b) With amortisseur	1.1
Induction motors	1.0

There is, however, a fourth factor which must be considered. This is one which will deal with the question of displacement.

It has already been pointed out that in a reactive circuit the current and voltage are in quadrature. Therefore, if a short-circuit occurs in such a circuit at the instant of zero voltage, the current should be at its maximum value, whereas it obviously is at zero. To explain this, we must refer to the fundamental equation for an a.c. circuit

$$Ri + L(di/dt) = E \sin(\omega t + \phi) \quad . \quad . \quad . \quad . \quad (59)$$

The solution of this equation contains two terms, one which is an exponential, and the other a sinusoidal.

Thus,

$$i = I_m \sin(\phi - \theta)t^{-R/L} + I_m \sin(\omega t + \phi - \theta) \quad . \quad . \quad (60)$$

The evanescence and unidirection of the exponential term give it the feature of a d.c. current of transient nature. It is therefore called the d.c. component. The sinusoidal term is called the a.c. component. Now the algebraic sum of these two components at any instant must equal the value of the fundamental or actual current.

If $\phi = \theta$, then $\phi - \theta = 0$; which is the condition obtaining when a circuit is closed in a reactive circuit at the instant of maximum voltage. But when $\phi - \theta = 0$, the transient term or exponential disappears, and therefore the current starts from zero and follows the sinusoidal term, or the a.c. component becomes the actual current and there is no displacement.

But when $\phi - \theta = 90^\circ$, which is the condition obtaining when the circuit is closed at voltage zero of a reactive circuit, the initial value of the d.c. transient is equal numerically to the peak value of the actual steady current, as will be seen by studying the exponential term in the equation above for i . And because the actual current is the sum of the two components, and also because at instant $t = 0$ the current equals zero, the a.c. component for this condition must be equal numerically although opposite in sign to the d.c. component. That is, the a.c. component starts at negative maximum. A quarter-cycle later the a.c. component is zero, and therefore the actual current is equal to the value of the d.c. component at this instant. Another quarter-cycle later the a.c. component is at positive maximum and the actual current is now equal to the sum of the d.c. component, which in this time has diminished but little from its maximum value, plus the peak value of the a.c. component, i.e. it is equal to practically twice

the normal peak value, or it is totally displaced. As time progresses, the following peak values of the actual current become less, in proportion to the diminution of the d.c. component, until, when the latter has disappeared, the actual current coincides with the a.c. component and becomes the sustained value and symmetrical. (See Fig. 110.)

During the above process, the voltage of the system will be in quadrature with the a.c. component, and when the latter is zero, the former will be maximum. Now the arc will be extinguished only when the actual current is zero, and the zero of the a.c. component will not occur at the same time as the zero

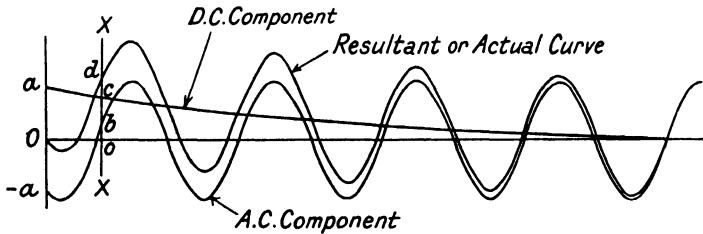

FIG. 110. ANALYSIS OF THE A.C. FUNCTION $Ri + L\frac{di}{dt} = \text{SIN}(\omega t + \phi)$

Numerically $oa = o(-a)$ and $od = ob + oc$ for any line xx .

of the actual current until the d.c. component has disappeared. Therefore, when the arc is interrupted at a given zero of the actual current, the value to which the restriking voltage will attain will depend upon the value at that instant of the current in the a.c. component. For instance, suppose interruption occurs when the a.c. current component is at a value $I_m \sin \delta$, then the voltage will be 90° ahead of this, and therefore the restriking voltage at that instant will be $E_m \sin(\delta + 90^\circ)$. Now at this instant of interruption the a.c. component of current will be equal and opposite to the d.c. component; therefore, if the number of cycles between short-circuit and interruption be known, the value of the d.c. component can be calculated from the equation

$$i_{ac} = Ie^{-t/T} \dots \dots \dots (61)$$

where I is the initial value of d.c. component; T the circuit time constant and t the time of duration of the short-circuit.

This value of i so found is also the value of the a.c. component at this instant, as explained. Therefore it can be expressed

$$i = I_m \sin(\omega t + \phi - \theta) \quad (62)$$

θ is the angle between voltage and current in the a.c. component which, in a reactive circuit, is 90° . Again, because the current at time $t = 0$ is zero, the angle ϕ vanishes and thus the equation reduces to

$$i = I_m \sin(\omega t - 90^\circ) \quad (63)$$

The voltage is, as explained, 90° ahead, and is therefore equal to

$$e_r = E_m \sin \omega t$$

The value of E_m in the above equation is obtained from equation (56), page 178, therefore $\sin \omega t$, which may be put equal to K_d , is the fourth factor to allow for displacement.

The final equation for restriking voltage therefore becomes

$$e_r = K_g K_s K_q K_d E_m \quad (64)$$

To summarize, we may note that if the short-circuit occurs near the generating plant, the equation for restriking voltage is that given by equation (64) above; the value of the constants involved in this equation for different types of machines being obtained from Table XI.

Equation (53) given on page 177 may be used if the value of Z is known for the machines.

Regarding the effect of neutral impedance, it can be noted that when the neutral impedance is a resistance, the restriking voltage will tend to start from near the zero value, and will increase in value as a logarithmic; whereas if the neutral is earthed through a reactor, the restriking voltage will rise instantaneously upon interruption to a given value.

The above indicates that the reactive load is more difficult to interrupt than is the resistive load.

High Frequency Effects on Restriking Voltage. There has been dealt with on page 173 the result of the condition when $R > \sqrt{4L/C}$ in the equation

$$Ri + L \frac{di}{dt} + \frac{1}{C} \int idt = E.$$

There is still the condition to be considered when $R < \sqrt{4L/C}$. As already stated, this gives an oscillatory character to the

surge, which is in effect the high-frequency surge oscillation to be considered.

Every circuit has inductance, capacitance and resistance present in some degree. When it has them in the proportion which gives $R < \sqrt{(4L/C)}$, then an interruption of that circuit will give rise to a voltage oscillation of frequency

$$f = \frac{1}{2\pi} \sqrt{\left[\frac{1}{LC} + \frac{R^2}{4L} \right]} \quad \dots \dots \dots (65)$$

and of amplitude $2E$, where E is the amplitude of the normal voltage wave. Furthermore, this high-frequency oscillation will be superimposed on the voltage wave at the system frequency. The high-frequency surge will travel along the circuit and, in the case of open-ended transmission lines, will be reflected completely, whilst at points of discontinuity, it will be partly reflected. These reflections may, by crossing, increase the value of the surge voltage to an extremely high value.

In general, the resistance value in a short-circuit is small compared with that of reactance, in which case it can be ignored. The equation for the high-frequency oscillation then reduces to

$$f = 1/2\pi\sqrt{(LC)} \quad \dots \dots \dots (66)$$

This is, of course, for a lumped impedance, but for a distributed impedance, such as is represented by a transmission line, the equation becomes

$$f = 1/4\sqrt{(LC)} \quad \dots \dots \dots (67)$$

The better to exemplify the above to the calculation of restriking voltage, the following example is given—

EXAMPLE. Consider the test for breaking capacity on an e.h.v. oil circuit-breaker. Let the circuit be as shown in Fig. 111 and let the apparatus be of characteristics as follows—

Generator

- 48 000 kVA. 11 000 V., star connected, solidly earthed neutral.
- Quadrature sub-transient reactance 11 per cent.
- Direct sub-transient reactance 10 per cent.
- Synchronous reactance 13 per cent.

Transformer

45 000 kVA.

Ratio 11 000/27 000 V.

Leakage reactance 8 per cent.

Capacitance to ground $0.007 \mu\text{F}$.

Normal Full-load Current = 1 030 A.

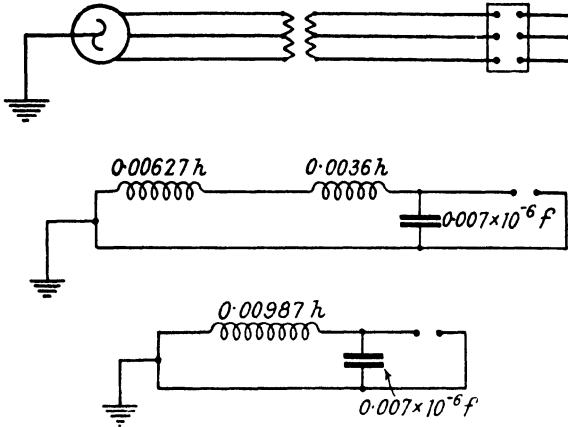

FIG. 111. CIRCUIT CONNECTIONS AND EQUIVALENT CIRCUITS FOR A THREE-PHASE UNEARTHED SHORT CIRCUIT ON A SOLIDLY EARTHED SYSTEM

The various reactance values referred to h.t. become—

$$x_q'' = 1.665$$

$$x_d'' = 1.515$$

$$x_g \text{ (for generator)} = 1.97$$

$$x_t \text{ (for transf.)} = 1.243$$

Therefore

$$S_q'' = 1.665 + 1.243 = 2.908$$

$$S_d'' = 1.515 + 1.243 = 2.76$$

and

$$\frac{S_q''}{S_d''} = \frac{2.908}{2.76} = 1.055 \text{ equals } K_q \text{ of equation (64)}$$

Also,

$$i'' = \frac{15\,600}{2.76} = 5\,650 \text{ A.}; \quad \text{where } 15\,600 \text{ is phase-to-neutral voltage.}$$

And,

$$i = \frac{15\,600}{1.97 + 1.243} = 5\,000 \text{ A.}$$

Therefore,

$$\frac{i}{i''} = \frac{5\,000}{5\,650} = 0.887 = K_a \text{ of equation (64).}$$

The short-circuit becomes a three-phase unearthed short on a solidly earthed system. Therefore, from page 179 the value of $K_g = 1.5$.

The value of the fourth factor K_d may be obtained thus—Suppose the short-circuit to endure for 3.8 half-cycles and that the current wave is totally displaced. The value K_d is, from page 182, $\sin \omega t$ and $t = 0.01 \times 3.8 = 0.038$ sec.

Therefore $\omega t = 11.9 = 682^\circ$, and $\sin 682^\circ = 0.79 = K_d$.

The value of the restriking voltage therefore becomes from equation (64)

$$\begin{aligned} e_r &= 1.5 \times 0.887 \times 1.055 \times 0.79 \times 15\,600 \times \sqrt{2} \\ &= 24\,400 \text{ V.} \end{aligned}$$

If the resistance of the circuit is such that $R < \sqrt{(4L/C)}$, this restriking voltage wave is oscillatory. This means that the pressure will oscillate between zero and twice the value given above. The frequency of this oscillation will be obtained thus. From the transformer reactance of 8 per cent the leakage inductance is found to be 0.0036 H., and the generator inductance 0.00627 H. The transformer capacitance is given as 0.007×10^{-6} F., and the generator is solidly earthed. Neglect the capacitance to earth of the leads between the h.t. transformer windings and the oil circuit-breaker. Then, the frequency of oscillation is

$$\begin{aligned} f &= \frac{1}{2\pi\sqrt{[(0.00627 + 0.0036)(0.007 \times 10^{-6})]}} \\ &= 18\,900 \text{ cycles per sec.} \end{aligned}$$

From which the rate of rise of restriking voltage is

$$\begin{aligned} &24\,400 \times 4.5 \times 18\,900 \times 10^{-6} \\ &= 2\,040 \text{ V. per } \mu\text{sec.} \end{aligned}$$

The factor 4.5 is the tangent for an undamped wave, or the steepness of a line drawn from the zero point and tangential to the voltage curve. In practice there will be some resistance damping present, and the value 4.5 will be modified according

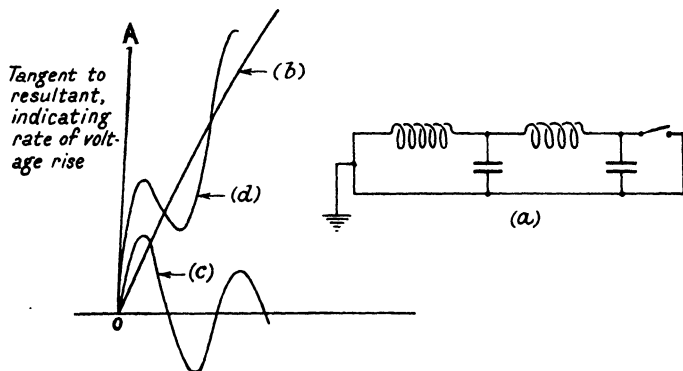

FIG. 112. EFFECT OF DOUBLE FREQUENCY CIRCUIT
 (a) = Equivalent circuit. (b) = First natural frequency.
 (c) = Second natural frequency. (d) = Resultant frequency.

to the extent of this. As an average value the figure 4.35 may be taken as representative.

In the above example it has been assumed, for the sake of simplicity, that the circuit contains but one natural frequency, whereas in practice it is more probable that it will have two or more such frequencies. In fact, for the case given, there would be a capacitance between the machine windings and earth, and this would make the equivalent circuit in accordance with Fig. 112, *a*. Such a circuit would have a double frequency, and the oscillations of these two frequencies would superimpose on each other to give a resultant frequency. Thus suppose in Fig. 112 the curve *b* represents one of the natural frequencies of the circuit, and the curve *c* represents the other, then the resultant frequency curve would be that given by the curve *d*. In this case the rate of rise of restriking voltage is represented by the steepness of the tangent *OA*.

The whole problem of multiple frequency circuits is rather complex, and the reader is referred to the bibliography at the end of the chapter for particulars of articles that deal more fully with the question.

Breaking Capacity. The breaking capacity of a circuit-breaker is clearly its capacity to interrupt a given load. The power to do this reaches its maximum at the instant of arc interruption, since at this instant the current is still at a high r.m.s. value, and the voltage rises to a value much higher than that during the continuance of the arcing.

The interruption of the load commences when the circuit-breaker contacts part, and is complete when the arc ceases to restrike after zero. During this period of arcing, the current decreases from an initially high value to some lower value dependent upon the conditions of the short-circuit. The voltage at the instant of contact separation is practically zero, but commences to increase in value following the creation of the arc. It continues to increase in a fairly regular manner as the arc lengthens, until, after the last current zero, it rises rapidly to the restriking voltage figure. This restriking voltage may, or may not, be greater than the peak value of the system voltage, as will be gathered from what has gone before. Whatever the value is, it is this value which is the critical one in the breaking capacity of the circuit-breaker.

The breaking capacity of a circuit-breaker is obtained by the work done in a given time. Thus, if t is the time of the arc duration, I the mean current in amperes and E the voltage, the work represented by interruption is

$$EIt \text{ volt-ampere-seconds.}$$

This work has been dealt with in t sec., therefore the power represented is EIt/t or EI volt-amperes. It is unfortunate that all countries do not agree upon how the voltage and current shall be measured; therefore the rated breaking capacity of an oil circuit-breaker will depend upon the country which assigns the rating.

The British standard convention for breaking capacity is to take as the current factor the r.m.s. value of current at the instant of contact separation, and for the voltage factor, the r.m.s. value of the first major half-cycle of voltage after the arc has been extinguished.

This value is known as the recovery voltage.

Thus the breaking capacity per pole is

$$I \times E \dots \dots \dots (68)$$

Where I = r.m.s. current at the instant of contact separation, i.e. at the instant $G - G$ in Fig. 113, and E = r.m.s. voltage of the first major half-cycle after the arc is extinguished.

The kilovolt-amperes broken in the three-phase circuit is the product of the above and the phase factor, i.e. 1.73, 2 or 1 for three-, two- or single-phase circuits respectively.

When the short-circuit current is displaced, the r.m.s. value of the current to be used in the equation for breaking capacity must include the d.c. component. This value is obtained thus

$$I = \sqrt{[(AC)^2 / \sqrt{2} + (DC)^2]} \dots (69)^*$$

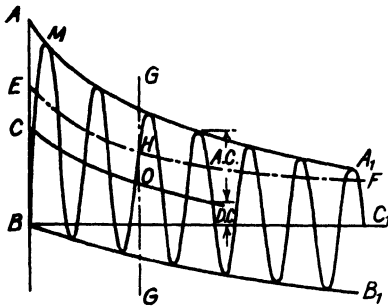

FIG. 113. CURRENT CURVE FOR AN ASYMMETRICAL SHORT CIRCUIT

The making capacity is given by the product of the peak value of the current in the first major half-cycle after the arcing contacts make circuit, the rated voltage

of the system, and the phase factor. The making current is that represented by BM in Fig. 113.

As an example in the calculation of short-circuit breaking capacity from data obtained from an oscillogram record of a test, consider the following, which is based on an actual test carried out on a 33 000 volt oil circuit-breaker and for which the oscillogram is shown in Fig. 114. It will be noted that the current in the yellow phase is totally displaced. This means that the short-circuit occurred at the instant of zero voltage on the yellow phase voltage wave. The oscillogram does not show this phase voltage but shows only the yellow-to-blue line voltage.

The first phase to clear in this short-circuit test was the yellow phase, which did not remake after the point marked X on the oscillogram. The maximum peak value of current in this phase was 10 200 A., obtained from the scale on the oscillogram. The "breaking current" (B.S.I. designation) is

* See Fig. 113.



FIG. 114. OSCILLOGRAM OF THREE-PHASE SHORT CIRCUIT TEST
(Metropolitan-Vickers Research Dept.)

the r.m.s. current at the instant of contact separation. In the test under review the contacts first parted at the time indicated by the line *PP*, see oscillogram in Fig. 114 and curve in

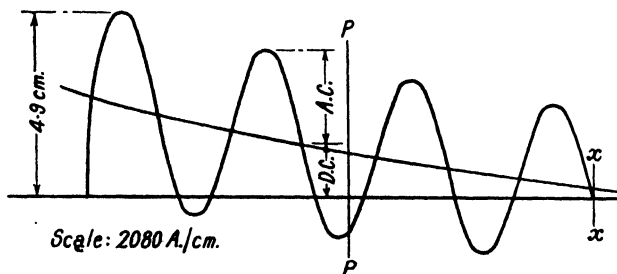

FIG. 115. CURRENT CURVE OF Y PHASE FOR OSCILLOGRAM IN FIG. 114

PP is instant of contact separation, and *xx* instant of arc extinction.

Fig. 115. Therefore the r.m.s. value of the current contains a d.c. component and is thus given by the expression

$$I_r = \sqrt{\left[\left(\frac{A.C.}{\sqrt{2}}\right)^2 + (D.C.)^2\right]}$$

which from Fig. 115 has the following numerical value

$$I_r = \sqrt{\left[\left(\frac{4\ 360}{\sqrt{2}}\right)^2 + 2\ 500^2\right]} = 3\ 960\ \text{A.}$$

The voltage factor is obtained from the value *oa* given on the oscillogram for the first major half-cycle after the arc extinction. This, however, represents the *Y-B* voltage, whereas the value required is that of the voltage across the yellow phase arc. Upon reference to Fig. 109 (*b*) it will be seen that the voltage across the arc is equivalent to the vector *XZ*, which, in terms of the *Y-B* voltage, is equal to $\sqrt{3}(YB)/2$. From the oscillogram Fig. 114, *YB* measures $1.5 \times 25\ 000$ or 37 500 volts; whence the recovery voltage factor is $(\sqrt{3})/2 \times 37\ 500 = 32\ 500$. Thus the breaking capacity for the three-phase breaker is

$$3\ 960 \times 32\ 500 \times 1.73 = 222\ 000\ \text{kVA.}$$

In order to determine the value of the restriking voltage, it is necessary to analyse the oscillogram still further. Thus, (*a*), Fig. 116, represents the arc voltage curves for the yellow and blue phases independently, whilst (*b*) gives the resultant arc voltage curve across these two phases. It will be seen that,

at the instant of zero arc voltage on the yellow phase, the arc voltage across the Y - B phases has the value oy as shown in Fig. 116 (b).

It is presumed that the nature of the circuit is such that high frequency oscillations will occur upon arc interruption. In this case the voltage across the yellow and blue phase arcs immediately before interruption of the yellow phase arc is that represented by Oy ; whereas at the instant of extinction

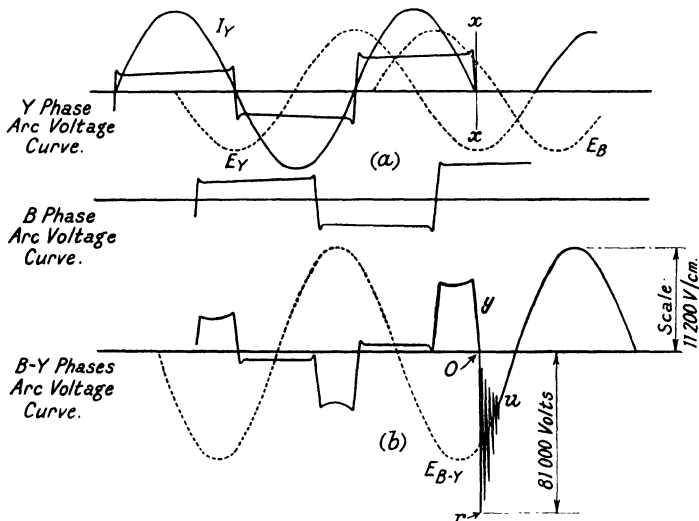

FIG. 116. DIAGRAMMATIC OSCILLOGRAM OF SHORT-CIRCUIT TEST ON OIL CIRCUIT-BREAKER

of the yellow phase arc this voltage should be equal to the normal B - Y line less the voltage drop in the blue phase arc. Therefore, the high frequency oscillation will start from the point O in Fig. 116 (b) and will rise to the value O_r , which is twice the value of the normal B - Y voltage at that instant.

From the oscillogram, Fig. 114, this value of restriking voltage is $2 \times 1.5 \times 26\,900$, i.e. $2 \times 1.5 E_\phi$, where E_ϕ is the peak value of the normal phase voltage; whence restriking occurs at 81 000 volts.

BIBLIOGRAPHY

- C. Dannatt and S. E. Goodall, *Electrician*, April, 1935.
- C. H. Flurschein, *J.I.E.E.*, Vol. 76, 1935.
- R. H. Pask and W. F. Skeats, *Trans. A.I.E.E.*, Vol. 50, 1930.
- R. M. Spurk and W. F. Skeats, *Trans. A.I.E.E.*, Vol. 53, 1933.

CHAPTER IX

OIL CIRCUIT-BREAKER DESIGN

General Features. This section deals with a number of features in the design of oil circuit-breakers which are in themselves too small to warrant a separate section for each. Thus, in Figs. 117, 118 and 119 are given the approximate overall dimensions of various sizes of breakers, and these figures may be used to determine the space to be allotted to the breaker in the lay-out of the station apparatus. From the illustrations in this figure it will be noticed that the conventional type circuit-breakers are divided into three groups—

(1) Frame-mounted breakers with separate tank for each phase.

(2) Frame-mounted breakers with all three phases in one tank.

(3) Floor-mounted breakers.

The first two groups include breakers for voltages up to 88 kV. At voltages higher than this, the weight of the tank with its oil makes the breaker too heavy for frame mounting, so that floor mounting becomes a necessity. A further reason against mounting the higher voltage breakers on a frame is that the height of the terminals above ground level would tend to make an uneconomical station lay-out. Group (3) may therefore be considered to apply to breakers above 88 kV.

The high voltage oil circuit-breaker is generally designed for outdoor use because, for economical reasons, high voltage installations are seldom made indoors. When an indoor circuit-breaker is required, the outdoor circuit-breaker can be made to suit this condition with but little alteration.

Two of the principal demands that outdoor use imposes on the circuit-breaker are that correct operation shall be certain in all weathers, and that deterioration caused by exposure shall be reduced to the minimum. The latter requirement can be satisfied by a robust design and sound construction, and by the absence of small parts that are likely to corrode quickly. Also, if the contour of the breaker is free from crevices that would harbour water, all joints are adequately protected, and if the surface is treated with a good paint, the life of the breaker will

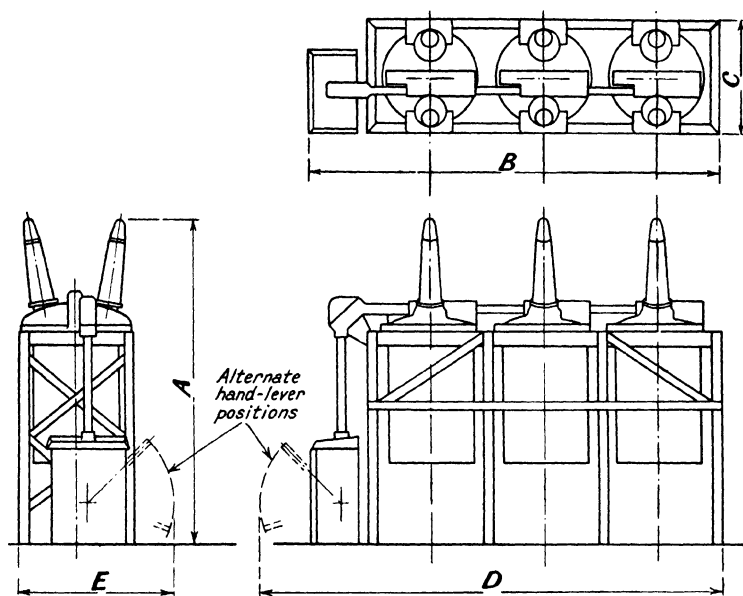

FIG. 117. OUTLINE OF FRAME MOUNTING OIL CIRCUIT-BREAKER HAVING SEPARATE TANKS FOR EACH PHASE

Used up to 88 kV.

VOLTAGE		DIMENSIONS				
		A	B	C	D	E
33 000	in.	124	146	46	176	80
	mm.	3 149	3 708	1 168	4 470	2 032
44 000	in.	138	192	58	222	87
	mm.	3 505	4 876	1 573	5 638	2 210
66 000	in.	160	210	66	240	87
	mm.	4 064	5 334	1 676	6 076	2 210
88 000	in.	170	227	68	257	98
	mm.	4 318	5 765	1 727	6 528	2 489

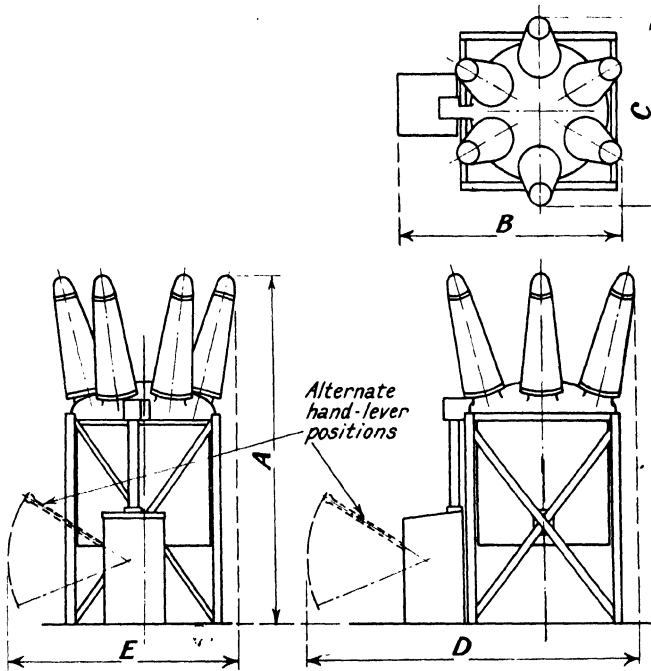

FIG. 118. OUTLINE OF FRAME MOUNTING OIL CIRCUIT-BREAKER HAVING ALL PHASES IN ONE TANK
Used up to 88 kV.

VOLTAGE		DIMENSIONS				
		A	B	C	D	E
33 000	in.	136	97	80	133	104
	mm.	3 454	2 464	2 032	3 278	2 642
44 000	in.	144	103	86	139	110
	mm.	3 658	2 717	2 184	3 531	2 794
66 000	in.	172	103	86	139	110
	mm.	4 419	2 717	2 184	3 531	2 794

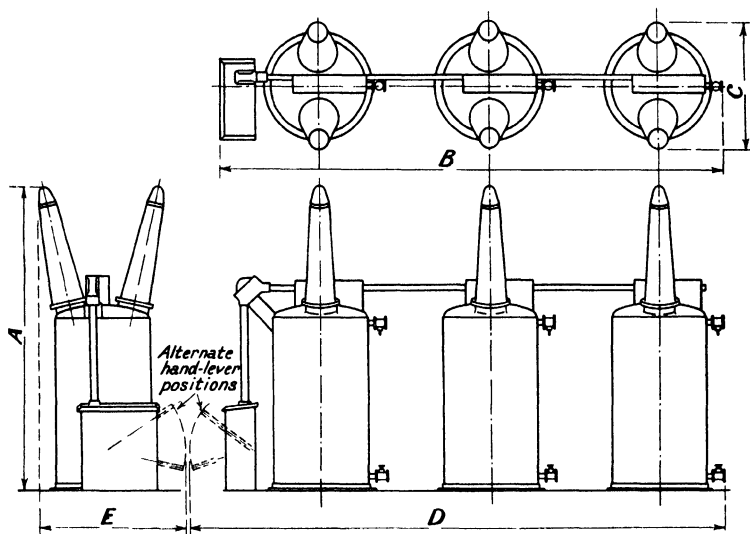

FIG. 119. OUTLINE OF FLOOR MOUNTING OIL CIRCUIT-BREAKER
HAVING SEPARATE TANKS FOR EACH PHASE

Used for voltages above 88 k . .

VOLTAGE		DIMENSIONS				
		A	B	C	D	E
110 000	in.	174	250	72	286	87
	mm.	4 420	6 350	1 820	7 264	2 210
132 000	in.	196	280	100	316	112
	mm.	4 978	7 112	2 540	8 026	2 845
165 000	in.	240	309	108	345	114
	mm.	6 095	7 848	2 743	8 763	2 895
220 000	in.	277	456	131	492	117
	mm.	7 036	11 582	3 327	12 497	2 782

be not only considerably extended thereby but correct operation will also be aided.

There are temperature variations in all countries, and due allowance must be made for the expansions and contractions that result from such variations. An example of this may be given by citing the effect that temperature change has upon the terminal bushings. The coefficient of linear expansion of brass is 0.0000189 per degree C., and for porcelain 0.00000416 per degree C. If it be assumed that the central conductor of a particular bushing is 108 in. long at 0° C. and the length of the top porcelain housing is 56 in. at 0° C.; then at 60° C. the porcelain will have increased in length by 0.014 in. and the conductor by 0.122 in. Such a variation is quite sufficient to break an oil- or compound-tight joint. It is therefore necessary so to design bushings that such differences in expansion cannot stress the construction.

Oil. The oil in the breaker tank will become more viscous as the temperature drops, and for this reason a special low freezing point oil is marketed for use in countries where the temperature is likely to fall to very low values. The B.S.S. No. 148—1933 gives particulars of the three standard grades of oil recommended, and grade A.30 or B.30 is that specified to maintain its fluid properties down to a temperature of — 30° C.

Condensation. Condensation inside the circuit-breaker tank is unavoidable in locations that are subject to a very humid atmosphere. In most designs the liberal electrical clearances used and the baffled venting arrangements provided render any further precautions unnecessary. In certain cases, however, engineers request that heater elements be fitted inside the oil tank to prevent condensation. Such heaters are usually situated just below oil level, and may be ordinary electric lamps of sufficient capacity. The heat dissipated will be that given by the watt value of the lamps or other heaters, but must be sufficient to maintain the temperature within the tank at a few degrees above that of the outside temperature. The size of heater required will depend on the temperature difference desired, and upon the superficial area of the outside radiating surface. As a general guide, the following example may be helpful.

It was desired that the top layer of oil in a circuit-breaker tank should for a depth of 4 in. be maintained at a mean temperature of 8° C. above that of the surrounding atmosphere.

The area of surface from which heat loss took place was approximately 8 000 sq. cm., made up of the top surface and tank side to the 4 in. depth. The loss from the remainder of the tank was ignored. Assuming the surface dull black and the ambient temperature of the order of 20° C., the heat loss for a mean temperature rise of 8° C. was approximately 0.009 watts per sq. cm. Therefore in the example the total loss was

$$8\ 000 \times 0.009 = 72\ W.$$

Vermin. It is necessary that all vents and ventilation holes shall be adequately protected against the ingress of vermin. A metal gauze is the usual method of effecting this protection, but the gauze should be durable and therefore made of a non-corrosive metal.

General Construction. In frame-mounted breakers, the general construction is that each single pole unit is mounted on the top plate or tank cover. Thus this cover carries the lead-in bushings, to which are attached the stationary contacts, the contact lifting mechanism, moving contact and buffer gear. Where separate tanks are used for each phase, provision is also made in the top cover for the inter-connecting link gear that couples the three single-pole units to the main operating mechanism; or, in the case of Arens rod control (see page 238), provision is made in the top cover for coupling this rod control with the moving contact lifting rod.

In the three separate pole circuit-breaker it is desirable that leakage of gas shall not be possible between the three single-pole units, and for this reason it is necessary that the interconnecting rods between poles shall be coupled to the contact lifting gear in a small chamber, separate and sealed from the air chamber formed by the breaker top cover and tank. With circuit-breakers of the Arens control type of operation, this is unnecessary because each single-pole unit has its own separate operating rod.

Pole Interconnecting Gear. The interconnecting gear between breaker units may be in the form of rods, links or any other arrangement to suit the idea of the designer. The essential is that adjustment can easily be effected to ensure that all three units close and open simultaneously. In general, a rod or tube type of interconnecting link is used, particularly for breakers of large size, because these represent the most economical sections for strength. Such links are contained in a

housing to protect them from the weather, and this housing may very well be standard steam pipe of a size sufficient to accommodate the link in question. The joints between the links and lifting mechanisms of the separate units are made in the small chamber above referred to. The same precaution must be taken in the design of these joints as elsewhere in this class of apparatus, i.e. that there shall be no tendency to stick after an extended period of inactivity. To this end bronze alloy or stainless steel pins are desirable, and the metal of the link adjusting gear should be likewise considered. For instance, if such gear includes screw threads, these must be protected against the action of the atmosphere, or adjustment in the field becomes impossible. This protection may be simply the addition of a suitable grease over the thread surface.

Tanks. The oil circuit-breaker tank is in effect nothing more than an oil container, although it is true that it sometimes has to contain the oil under pressure. Most tanks have an insulation liner to prevent the arc from reaching earthed metal, and they are fitted with such adjuncts as oil gauge, filling, draining and filter valves, as well as oil sampling cocks.

The cylindrical shape is undoubtedly the best from the point of view of pressure resistance for minimum thickness of wall, but, nevertheless, there are occasions when the cylindrical is not the most economical shape. From the standpoint of electrical clearance with the conventional three-tank double-break circuit-breaker, the most economical shape is that of a rectangle with semicircular ends. For relatively small capacity breakers this shape can be used with advantage, and it can be designed to withstand quite satisfactorily test pressures up to about 50 lb. per sq. in. Such tanks are generally constructed of rolled boiler plate, and are reinforced with ribs welded on to give the required strength. The neutral axes due to bending stress for a tank of this shape are about the positions where the semicircular ends meet the straight sides, and the reinforcing ribs can be shaped to follow roughly the stress diagram accordingly. The maximum bending stress, M , on the tank side is, if we adopt the expression given for the elliptical shape, given by the equation

$$M = (P/2)(a^2 - K_x^2 - K_y^2) \quad . \quad . \quad . \quad . \quad . \quad . \quad (70)$$

where P is the internal pressure per unit area, a is half the major axis, and b half the minor axis. $K_x^2 = b^2/2$ and $K_y^2 =$

$a^2/2$. To this must be added the direct tensile stress, in order to obtain the total stress to which the tank is subjected.

The weight of a tank complete with oil is considerable, and some convenient method of lowering it to the ground is necessary when frame mounting is used. Apparatus for this purpose may take the form of a tank carriage in which is incorporated a screw lowering gear. An alternative scheme is to use a portable worm and wheel winch which can be attached to the circuit-breaker frame. The middle of the steel cable is attached to the centre of the drum and the cable ends are provided with hooks. The cable is led from the drum over pulleys, which are located in suitable positions on the circuit-breaker frame, to the tank, where the hooks are attached to suitable eyelets.

Floor Mounting. As regards the large circular tanks for breakers of high breaking capacity, these are mostly designed with a concave top and bottom welded or riveted to the main body of the tank. Although some manufacturers adhere to the practice of making the tank top separate from the body of the tank, there seems no clear reason for this. The one-piece tank, built on the principles of boiler construction, seems undoubtedly the preferable method. These tanks are for floor mounting, and for this purpose the tank body is extended beyond the curved bottom in the form of a skirt, and thus provides a steady support for itself, as well as facilitating the painting of the bottom. Access to the interior of these tanks is by a man-hole, which may be in either the top or side of the tank. It therefore becomes essential that all parts to be fitted within the tank shall be of dimensions that will pass through the man-hole. Furthermore, there must be sufficient space within the tank for the fitter to work on the assembly of these parts, as well as upon any adjustments or replacements that become necessary after installation.

Maintenance. The bursting of the tank of a floor-mounted circuit-breaker is so rare an occurrence that the possibility can be ignored. Therefore it can be reckoned that all maintenance work on breakers of this kind will be carried out on the breaker *in situ*. This renders the addition of any device to facilitate the movement of the breaker a refinement rather than a necessity. Such refinements are sometimes specified, and these may take the form of a device that is a combination of detachable wheels and lifting jack, or, of course, the tank may be fitted with permanent wheels; a fairly common practice

200 OUTDOOR HIGH VOLTAGE SWITCHGEAR

on the Continent. Again, sometimes a truck with a lifting device included is used for the purpose.

One difficult task of maintenance is the replacement of a breaker bushing terminal. The failure of a high voltage bushing terminal seldom happens, but when such an event does occur it is very desirable to remove the faulty article and replace it with a sound one in the shortest time. On frame-mounted

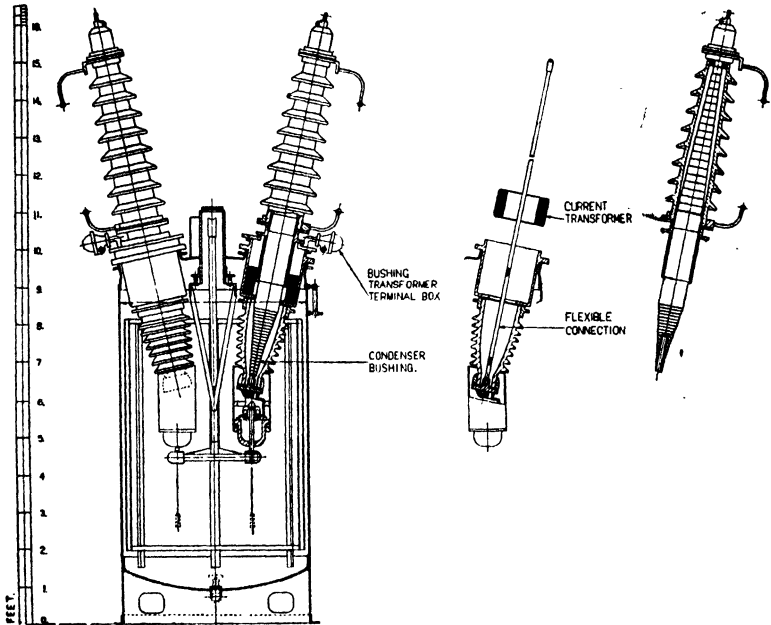

FIG. 120. METHOD OF REMOVING A CONDENSER BUSHING FROM AN OIL CIRCUIT-BREAKER

(Metropolitan-Vickers Elec. Co. Ltd.)

breakers the task is comparatively easy, because the tank can be quickly lowered and access to the breaker interior obtained; but with the floor-mounted breaker the problem is more difficult. In most of the latter cases it is necessary to empty the oil from the tank and remove the stationary contacts before the removal of the actual bushing can begin.

There is a design, however, that avoids the necessity for emptying the tank of oil and removing contacts, etc., and this is shown in Fig. 120. In this design the bushing is used as an insulating tube only, in that its central tube does not carry the

current. The breaker stationary contact, which is normally attached to the oil end of the bushing, is in this case fixed to an independent porcelain, which latter also acts as the arc shield for the bushing and forms an oil container for the bushing end, separate from that of the tank. This porcelain is carried by a metal casing of cylindrical shape which fits into the aperture in the breaker top cover which is usually occupied by the bushing. The cylindrical casing provides accommodation for the bushing current transformers, as well as a mounting flange for the bushing itself. The conductor is a length of flexible cable, one end of which is connected to the stationary contact at the end of the fixed porcelain. The cable passes through the brass tube on which the bushing is wound, and the other end is clamped to a suitable terminal at the top end of the bushing.

From this it will be understood that the bushing can be withdrawn from the breaker without disturbing contacts or oil, or anything more than the unbolting of the cable terminal connection at the top and the flange bolts at the seating.

A further advantage of this type of breaker is that the contacts can all be correctly aligned in the manufacturer's shops, and need not be further disturbed on site by the installing of the bushing terminals.

~~OIL~~ CIRCUIT-BREAKER CONTACTS

Contacts of all types must satisfy two distinct requirements. First they must carry their rated full load current without excessive temperature rise. B.S.S. No. 116—1929 specifies a rise of 30° C. for currents up to and including 2 000 A. This requirement presents little difficulty, as normal ratings seldom exceed 600 A. The large volumes of oil required for insulation purposes at the higher voltages help in limiting temperature rise, and contacts designed for use at 11 000 volts may have their normal current rating increased from 20 to 30 per cent when used for 33 kV. and above.

The second requirement is that they should be capable of breaking and making their rated short-circuit current a specified number of times, and after such operation full load current must be carried without undue heating. This requirement, which influences the general design of the breaker as well as that of the contacts, is generally known as the *duty cycle*. It is dealt with in more detail later.

202 OUTDOOR HIGH VOLTAGE SWITCHGEAR

When the system voltage is 33 kV. or above, the current carrying portion of the contact is usually one of three types—

- ✓ Butt;
- ✓ Finger and wedge; or
- ✓ Plug and socket.

Butt Type. This contact is used extensively, as it embodies several desirable features. Provided sufficient contact pressure is applied, the contact area is unimportant (see Chapter VI).

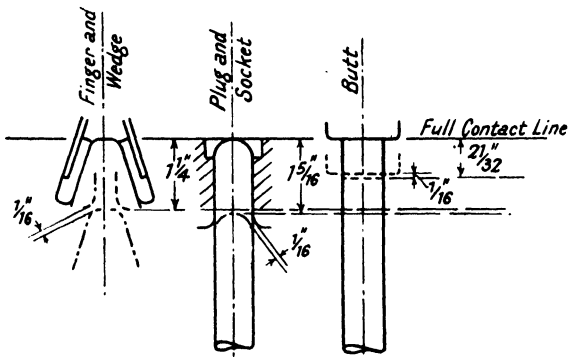

FIG. 121. DIAGRAM SHOWING THE TRAVEL NECESSARY TO OPEN THREE TYPES OF CONTACT

It is therefore possible to allow arcing to take place on the main contact and thus dispense with arcing contacts.

Impetus is given to the moving contact on opening, as the springs provided to obtain the contact pressure when closed function as throw-off springs when the breaker is tripped. In this respect the butt type contact is unique.

The motion between the first movement of the cross bar and the parting of the contacts is less with the butt contact than with other types. The amount of such motion, which may vary between $\frac{1}{4}$ in. and $\frac{3}{4}$ in., should be kept to a minimum, as the time lag between the inception of a short-circuit and the arc forming at the contacts is thereby reduced. Fig. 121 shows the advantage gained by a butt contact having a $\frac{5}{8}$ in. compression, compared with typical finger and wedge, and plug and socket type contacts.

The temperature rise at rated current depends upon the contact pressure and the provision of sufficient metal in the

contact itself to dissipate satisfactorily the heat generated. This latter requirement is usually more than met by the dimensions necessary to ensure mechanical strength for contacts up to 600 amperes.

Two examples of modern butt contacts are shown in Fig. 126. Their sturdy simple design should be noted. Contact pressure may vary considerably with different designs. A guide may,

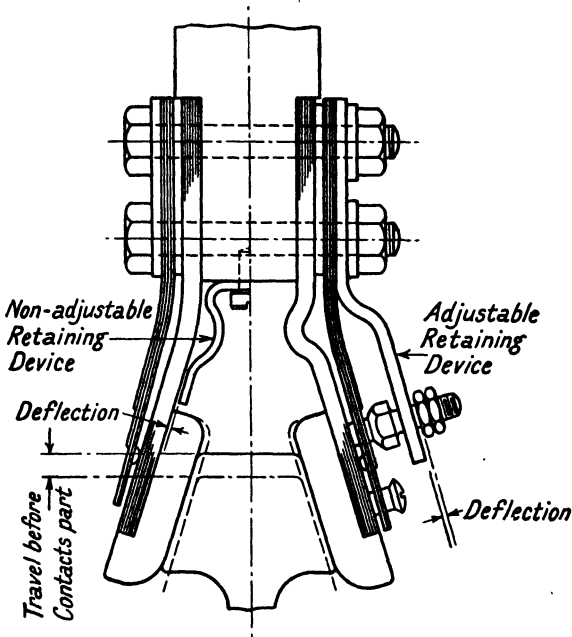

FIG. 122. TYPICAL FINGER AND WEDGE MAIN CONTACT SHOWING TWO TYPES OF RETAINING DEVICES

however, be taken from a normal 600-ampere contact constructed from $1\frac{1}{2}$ in. diameter rods and similar in construction to Fig. 124. In such a case a pressure varying between 150 and 200 lb. would give satisfactory operation.

Finger and Wedge Type. This form of contact is favoured by a number of manufacturers, and the same general design used for the lower range of voltages is quite suitable for high voltage application. At the smaller breaking capacities where open contacts are satisfactory, they are used for both main and arcing contacts. In cases where a main contact is necessary in

addition to an arc control device contact, the finger and wedge pattern is often chosen for the former.

In order to obtain the maximum lead between the main and arcing contacts, the angle of the wedge on the main contact should not be less than 34° . A retaining device to restrict the travel of the fingers to approximately $\frac{1}{16}$ in. is also necessary. (Fig. 122.)

Plug and Socket Type. This contact is used in several types of arc control devices. The socket segments and the moving plunger can be so shaped that arcing takes place on a different portion of the contact from that used for carrying the main current; thus a main and arcing contact is combined in one assembly. The power necessary to close a circuit-breaker fitted with this type of contact is less than that required for a similar circuit-breaker fitted with butt contacts. As an example, the power required at a solenoid mechanism to close a certain circuit-breaker fitted with plug contacts was 19 kW.; an increase of 7 kW. was necessary when butt contacts were fitted.

Modern types of plug and socket contacts are illustrated in Figs. 123, 125, 127 and 131.

Most early types of breakers used contacts that drew an unrestricted arc in the open tank, but the use of such contacts should be limited to the lower range of breaking capacities.

In the light of present day knowledge, it is difficult to realize that contact design remained unaltered in principle for all voltages and breaking capacities until about 1929. Increase in breaking capacities was obtained by higher contact speed, the adoption of multi-breaks, greater mechanical strengths of tanks and mechanisms, increased head of oil above contacts, increased thermal capacity of contacts, and so on. The only device making any attempt to control the arc itself was the explosion pot. Operating experience and tests proved that inconsistency of operation existed at both high and low voltages. Without going deeply into the causes of these variations, at least one point seems certain. The drawing of an open arc in an oil breaker is accompanied by a rapid rise in hydrostatic pressure in the neighbourhood of the arc. There will usually be at least two such arcs in one tank. The pressure generated causes the oil to be thrown to, and reflected from, the uneven surfaces provided by the tank, mechanism and bushings. Uniformity of oil movement under such conditions would appear impossible. As oil turbulence has a direct bearing on

arc extinction, it would appear unreasonable to expect consistency of operation.

B.S.S. No. 116—1929 indicates the short-circuit operation efficiency expected. To summarize clauses 40 to 43, a circuit-breaker having once broken its rated short-circuit kVA. must be capable of again breaking this same power on closing (make-break) with a lapse of two minutes between the two breaks. Also, after such a cycle of operations, normal full load current must be carried without overheating.

This implies that some damage may have occurred, and examination and repair may be necessary before further short-circuits can be satisfactorily ruptured. It will be noted that in the framing of such requirements the well-being of the circuit-breaker only is considered.

The steady growth of generating plant and the interlinking of large power schemes increased the duty required and proved the breaker to be the weak link. Apart from the expense and inconvenience of inspection, operating times were in many cases sufficiently long to cause system instability.

Modern forms of arc control device have gone a long way to solve most of these problems.

Arc Control Devices. All the contacts described in this chapter have one principle in common—they utilize the products of the arc to effect its own extinction.

With these devices, however, there is at present no known method of ascertaining precisely the physical action that the oil and gases have in determining the extinction of the arc. Their efficiency can be proved by oscillograph records of short-circuit tests, and useful data may be obtained by careful examination after such tests.

The Theory of Operation of the Plain Explosion Pot. The plain explosion pot which has been in use for over twenty years was the first arc control device. It has remained practically unaltered in principle since its conception.

The original idea of its action was that the pressure generated within the pot was applied to the top of the moving contact plunger, thereby increasing its speed. That this does happen was substantiated by tests made by J. D. Hilliary in 1924. These tests also demonstrated that the beneficial action of the device was most marked at high currents. Later investigations have shown that the additional speed obtained is of secondary importance.

Referring to Fig. 123, it will be noted that the explosion chamber is provided with one outlet through which the moving contact passes. During the first portion of the opening stroke this outlet or *throat* is practically closed by the contact rod. The pressure generated within the chamber by the expansion

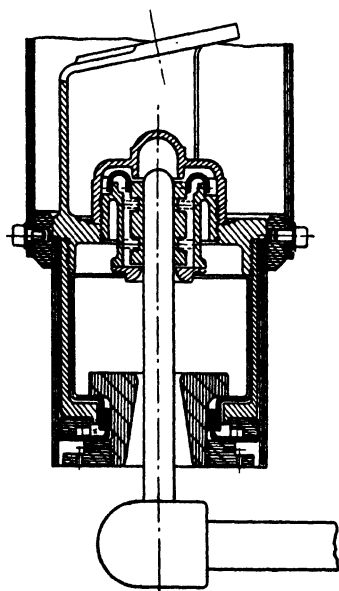

FIG. 123. SECTION THROUGH A PLAIN EXPLOSION POT CONTACT

of the volatilized oil is therefore held. As the moving contact passes out of the chamber, it is followed by the arc which then fills the throat. At this stage the chamber can discharge its contents, provided the internal pressure generated is sufficient to overcome the pressure in the arc stream itself. If such a condition exists, a blast of partly ionized gas and atomized oil is forced into the arc stream. The amount of deionization obtained will naturally vary with the pressure generated, which in turn is a function of the current in the arc. Thus, efficiency improves with increasing current—a very desirable feature.

The efficiency of this pot for rapid interruption falls quickly with diminishing current values.

In fact, for currents below a certain value, rapid interruption cannot be obtained. The blast through the throat at small currents need not be in contact with the arc, as the arc section will itself be small. For this reason the imprisoned gases and oil, in addition to having less pressure than at high currents, will also have a larger area for exit.

Explosion pots can be made more effective at these low currents by one or more of the following methods.

(1) Reducing the clearance between the plunger contact and the throat to a practical minimum, thus conserving internal pressure.

(2) Making the plunger contact diameter small, thereby reducing the pressure leakage area, and forcing the arc to pass

through a confined orifice which concentrates the deionizing blast.

(3) Providing maximum arc length within the chamber.

The limit to all three methods is the pressure generated within the chamber at high currents. Mechanical rupture of the chamber must not occur. Further, the circuit-breaker bushing which holds the complete contact must not be endangered by the mechanical reaction upon it when the contact rod leaves the throat. For these reasons throat and moving contact dimensions are often more liberal than theoretical design would require. The improvement in operation gained by a small throat diameter, mentioned in (2) above, has been proved by several authorities. In order to maintain this feature in high rupturing capacity breakers, vents are sometimes fitted in the top of the explosion chamber. By this means dangerous internal pressures are relieved.

The Oil-Blast Explosion Pot.

Fig. 124 illustrates the general construction of the oil-blast explosion pot which was first introduced by the General Electric Co., U.S.A. It differs from the original explosion pot in that two distinct arcs are drawn within the explosion chamber. Both contacts are of the butt type, the main moving contact being of tubular construction.

The first opening movement of the breaker separates the top pair of contacts, which travel through a predetermined distance before the main contacts part.

It is the duty of the arc which is drawn between the top contacts to provide a pressure within the chamber before the second contacts part. Immediately these latter contacts

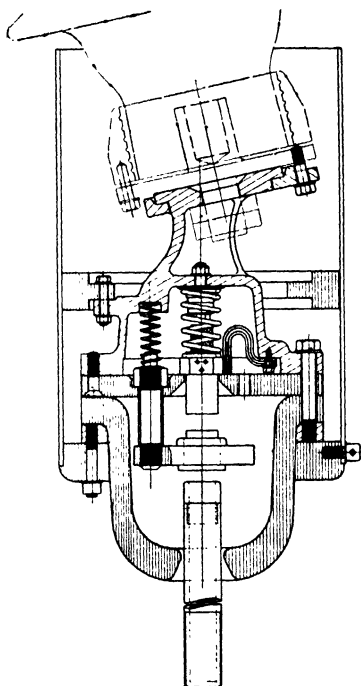

FIG. 124. SECTION THROUGH AN OIL-BLAST EXPLOSION-POT CONTACT
(General Electric Co., U.S.A.)

separate, there is an escape path from the pot via the hollow moving contact. The second arc is therefore attacked at its inception by the oil and gas forcing their way through the arc to escape down the tube. By this means a wall of insulation is forced between the contacts, the dielectric strength of the former finally building up at a greater rate than the rate of rise of the restriking voltage. This insulation barrier prevents re-establishment of the arc after the current wave has passed through its next zero. This principle of operation known as the *Displacement Theory* was first advanced by D. C. Prince, and quantitative evidence of its efficiency has been published by Prince and Poitras.

The important differences between this device and the normal explosion pot can be summarized as follows. The oil and arc products are forced to escape across and not round the arc. The attack upon the arc occurs immediately the second contacts break, and not when the contact leaves the throat of the pot. Thus, a reduction in arcing time is obtained. Internal pressure is relieved at the breaking of the second contact. This forms a safety-valve against mechanical rupture, and allows a small throat clearance to be used with a resulting gain in pressure conservation.

Table XII by Spurck and Strang gives a comparison of tests taken on circuit-breakers equipped with standard type of butt-contact explosion pots and oil-blast explosion pots. The line voltages for these tests were 136 kV. and 140 kV.

The main structural feature in explosion pot design is the provision of an explosion chamber that will withstand high internal pressures without mechanical rupture. Up to approximately five years ago all such chambers were of metal construction, Fig. 123, the interior insulation and throat being of bakelite. This construction proved very satisfactory for voltages up to 88 kV. Above this voltage the insulation of the throat became difficult. Puncture of the throat provided a parallel arc path to the metal pot outside the chamber. This difficulty was completely solved by the introduction of the insulated pot, Fig. 124.

Fig. 125 illustrates the A.E.G. solution of this same problem. It will be noted that the metal chamber is retained as an insert in the main body.

The De-ion Grid Contact. Fig. 126. The de-ion grid is based on the principal propounded by Dr. J. Slepian and is designed

TABLE XII
SUMMARY OF FIELD TESTS TAKEN AT 136 kV. AND 140 kV.
(Spurck and Strang)

Rate of Rise of Restriking Voltage	No. of Tests	Arc Duration, Cycles, Average	Arc Duration, Half-cycles, Average	Arc Length, Inches, Average
(Calculated Volts per μ sec.)	<i>Butt Contacts in Explosion Pots</i>			
270	17	6.2	12.4	15.5
600	4	7.1	14.2	17.0
2 400	7	15.0	30.0	24.5
Total test average	28	8.6	17.2	18.0
	<i>Oil-blast Contacts in Explosion Pots</i>			
270	15	2.6	5.2	4.5
600	9	3.7	7.4	7.1
2 400	16	4.1	8.1	8.8
Total test average	40	3.5	7.0	6.8

(A.I.E.E. Trans.—1931. Vol. 50.)

TABLE XIII
SUMMARY OF FIELD TESTS ON OIL CIRCUIT-BREAKERS FITTED WITH
DE-ION GRID CONTACTS
(L. W. Dyer)

Voltage	No. of Tests	R.M.S. Amperes Interrupted	Arc Duration in Cycles
66 kV.	29	1 050 to 6 970	1 to 3.5
110 kV.	14	896 to 3 860	1 to 4
220 kV.	16	1 100 to 2 950	2 to 4.5

{ *Elec. World*—April, 1930. }
{ *Elec. Journal*—March, 1930. }

to make use of the fact that ionized gas constituting an arc path is mobile and of negligible mass, while oil has appreciable mass and is therefore more difficult to move than the arc.

This contact was the first high voltage device to use horizontal barriers. The contact proper is of the butt type which, when in the closed position, is surrounded by a laminated structure of insulated plates. Escape vents are formed at one end of this structure, and a narrow slot is provided to allow free passage of the moving contact. This slot is omitted in the upper laminations, and the moving contact is shaped to avoid fouling.

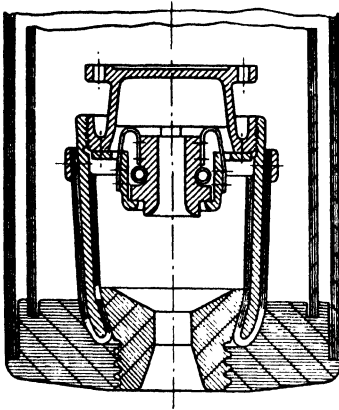

FIG. 125. SECTION THROUGH
EXPLOSION POT CONTACT
(A.E.G.)

An iron magnetic element is introduced at regular intervals in the assembly, and a number of the insulation plates are cut in such a manner that internal oil pockets are formed. The number of plates increases with voltage.

With the parting of the contacts an arc is drawn in a narrow slot which is open at one end only. This opening faces in the

opposite direction to that normally taken by the arc. The insulated iron inserts modify the magnetic field of the arc, thereby forcing it towards the closed end of the grids. This movement is aided by the normal magnetic blow-out effect caused by the inductive loop. During this movement the arc is brought into contact with the oil stored in the pockets, thereby generating gas. The expanding gases can only escape by passing through the arc stream to the open end of the slots. The arc is subjected thereby to a turbulent blast of un-ionized gas, which splits up the arc stream into a number of parallel paths, the space around which is filled with un-ionized gas. At current zero the gas diffuses into the space which was arc path, and the arc space is filled with a low ion density gas of considerable dielectric strength. The amount of gas generated is comparatively small, as most of the oil subjected to decomposition is that trapped in the grids. Furthermore, the

proximity of the insulation plates to the gases reduces the temperature of the latter, thereby aiding de-ionization.

A measure of the efficiency of the contact can be taken from the field tests recorded by L. W. Dyer, from which Table XIII was compiled. A test taken at 110 kV. with plain contacts,

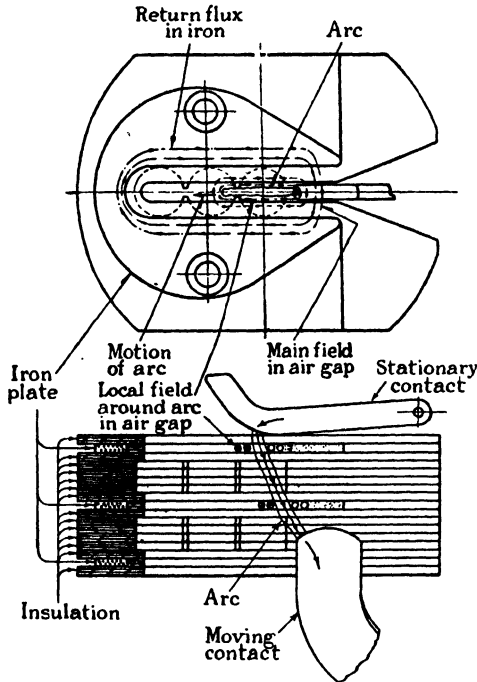

FIG. 126. DE-ION GRID CONTACT
(Westinghouse Co., U.S.A.)

but otherwise under the same conditions as those recorded, gave an arcing time of 13 cycles when breaking 3 500 A.

✓ Cross-jet Explosion Pot (Fig. 127). The current-carrying portion of this device is of the plug and socket type. The top metal section which is attached to the breaker bushing also houses the fixed portion of the contact and forms the upper section of the explosion chamber.

The cross-jet assembly is constructed entirely of insulation. The jet, complete with arc splitters and a top and bottom throat piece, is a sliding fit in a cylindrical bakelite container.

212 OUTDOOR HIGH VOLTAGE SWITCHGEAR

Clamping studs serve the dual purpose of fixing the container to the explosion chamber and clamping the jet assembly in position. At the lower voltages one or two arc splitters only are necessary, at 33 kV. three are used.

With each upward step of system voltage a corresponding

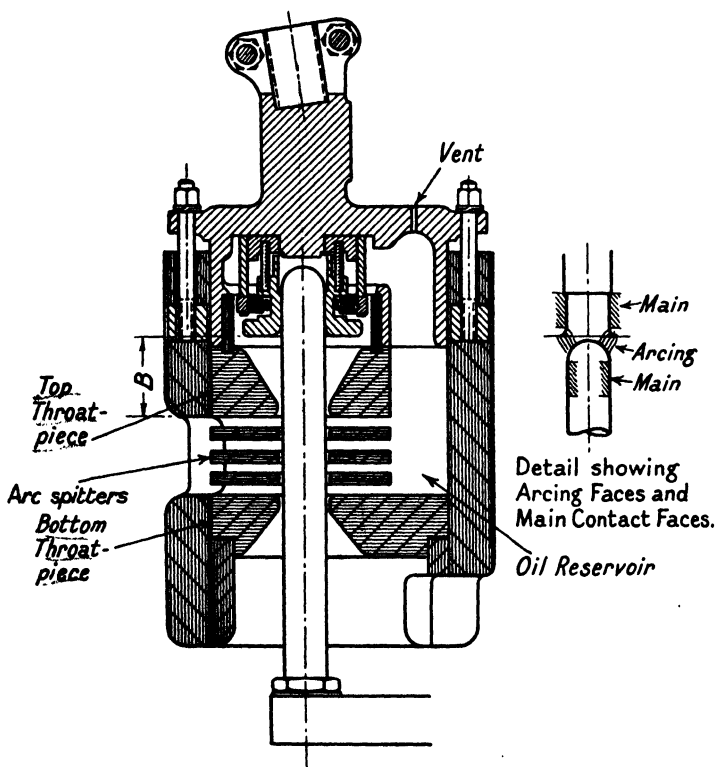

FIG. 127. SECTION THROUGH CROSS-JET CONTACT
(Metropolitan-Vickers, Elec. Co.)

rise in recovery voltage will occur, together with a decline in short-circuit current value. The adding of arc splitters caters for the increase in voltage and insures that rupture will occur before the moving contact leaves the bottom throat.

The pressure generated within the explosion chamber bears a direct relationship to the current in the arc. Adjustment is therefore made to obtain the desired pressure with different

current values by varying the arcing time within the explosion chamber. For example, dimension *B*, Fig. 127, may be increased for each higher system voltage value.

The first portion of the opening operation is similar to that of a normal explosion pot in that pressure is built up within the chamber by the entrapped arc. The explosion chamber connects directly with a reservoir of oil situated at the closed ends of the jets. This oil is protected from the arc in the chamber, but is subjected to the pressure generated thereby. As the moving contact enters the horizontal channel, the radial blast of gas and oil shot into the arc directly from the explosion chamber is greatly reinforced in its rupturing action by a flood of clean oil forced across the arc path by the pressure imparted to the oil reservoir from the explosion chamber.

Should rupture not occur at the first zero pause after the contact has passed the first arc splitter, the jet outlet is effectively sealed by the arc stream. Pressure can therefore build up until a value sufficient to cause rupture at a successive current zero. Fig. 128, which was prepared from an actual test, proves this. The drop in pressure at the first jet indicates that an unsuccessful attempt at rupture was made. From this point the pressure built up to approximately double the value available at the first jet. The cross-blast occurs at all jets exposed by the moving contact. Fig. 129 was taken when testing a 33 kV. breaker with plain open contacts; the average of the currents broken was 3 480 A. and the arcing time 7.2 cycles. Fig. 130 illustrates the same breaker fitted with a cross-jet explosion pot breaking 3 747 A., the arcing time in this case being 1.6 cycles.

The performance of the cross-jet explosion pot can also be judged by the fact that a single unit mounted in the circuit-breaker illustrated in Fig. 250 broke 10 800 A. at a recovery voltage of 70.8 kV. with an arcing time of 2.64 half-cycles.

The Turbulator Contact (Fig. 131). The current-carrying section of the device is of the plug and socket type. The stationary contact is attached to a metal base, which in turn is fixed to the bushing insulator. This contact is surrounded by a metal casting which forms an oil reservoir. Between this casting and the baffles, a distance piece of insulation is fitted. The baffle plates are so shaped that each alternate plate is provided with a vent. The throat, which is of bakelized paper, is self-aligning and fits closely round the moving contact, thus

sealing the enclosure. The whole assembly is securely clamped between a bottom metal ring and the top base plate by insulated steel studs. The bottom metal ring is shrouded by a ring of insulating material, and the complete enclosure is surrounded

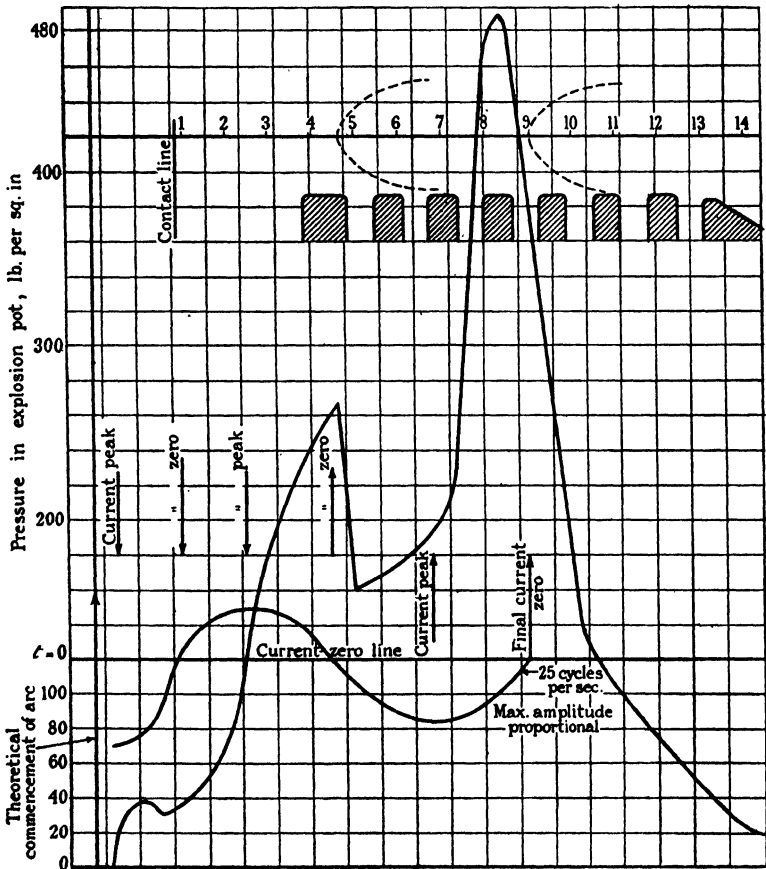

FIG. 128. PRESSURE/TRAVEL CURVE FOR CROSS-JET EXPLOSION-POT
(From paper by W. A. Coates)

by a bakelite paper tube, in which is provided an opening situated opposite to the vents in the baffle plates.

With the parting of the contacts, an arc is drawn in what is virtually a closed chamber, and the resulting generation of gas creates a high pressure in the enclosure. As the moving

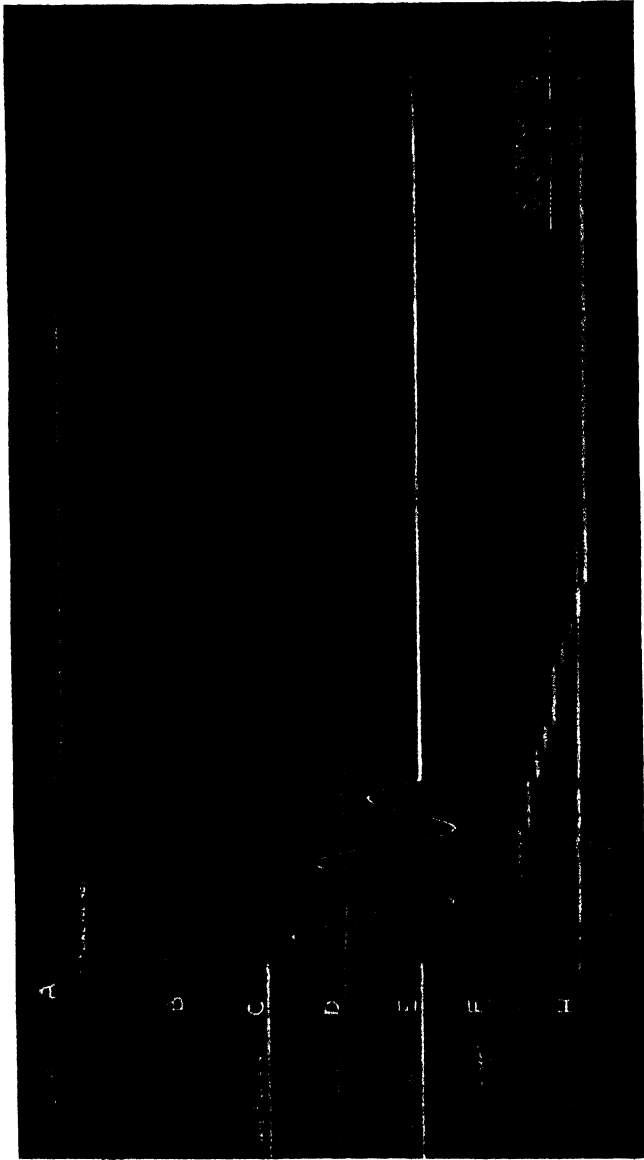

FIG. 130. TEST ON A 33 KV. OIL CIRCUIT-BREAKER WITH CROSS-JET EXPLOSION POTS

Scale: $A = 22\ 000\ \text{kW./cm.}$
 $B = 15\ 000\ \text{V./cm.}$
 $C = 1\ 600\ \text{A./cm.}$
 $D = 37\ 800\ \text{kW./cm.}$
 $E = 1\ 430\ \text{A./cm.}$
 $F = 1\ 790\ \text{A./cm.}$
 $G = \text{Travel indicator.}$
 $H = 25\ 3000\ \text{kW./cm.}$

(Metropolitan-Vickers Research Dept.)

contact recedes, the vents in the device are exposed. This action combined with the high pressure existing in the enclosure causes turbulence, and comparatively cool gas, oil vapour and oil is injected transversely through the ionized arc path with

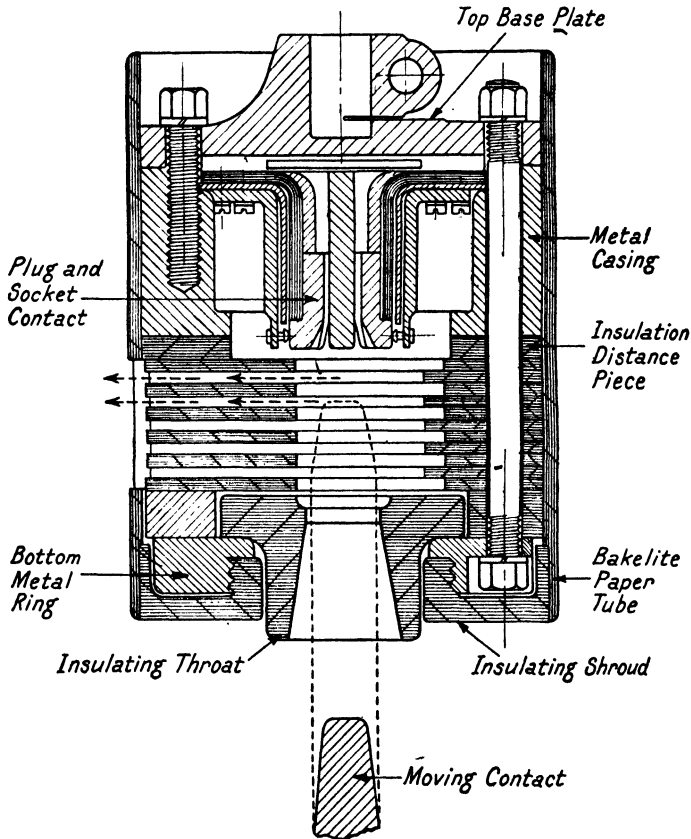

FIG. 131. SECTION THROUGH A TURBULATOR CONTACT
(A. Reyrolle & Co.)

consequent de-ionization. The expansion of the gas through the vents also causes a rapid drop in temperature, which further increases the rate of de-ionization. The shape of the baffle plates also provides pockets for cool oil, which aid the action. Any magnetic effect on the arc tending to lengthen it is resisted due to the construction of the enclosure.

All the arc quenching devices described shorten the duration of the arc. Thus arc energy, arc length, oil deterioration and contact burning are all reduced. A large measure of consistency in operation is obtained at all breaking capacities within the range of the breaker to which they are fitted. The test figures given in the text, together with those referred to elsewhere, give proof of this statement. Comparisons between these tests should be considered with caution, as erroneous conclusions can easily be made. As an instance, a variation in the rate of rise of restriking voltage at which the tests are taken can make considerable difference to the arcing time. (See Chapter VIII, page 172.) Comparisons yielding reliable conclusions are only possible when each device under consideration has been submitted to a complete range of tests under identical conditions.

There is little published data of British origin available that deals with arc control devices.

The fact that such devices are now becoming standard practice will result in this subject being given more attention, and the reader is advised to watch for articles and papers dealing with such matters.

ELECTRICAL CLEARANCES FOR OIL CIRCUIT-BREAKERS

Air Clearances. The air clearances used for isolating switches and connections must of necessity line up with those used for circuit-breakers. The minimum dimensions specified in B.S.S. No. 116—1929 and B.S.S. No. 162—1934, are therefore identical. The dimensions may appear large, but the hazard of clearance reductions caused by birds, blown twigs, etc., has to be allowed for.

Oil Clearances. The clearances necessary in oil for the higher range of voltages are not defined in any national specification. (The V.D.E. rules give oil clearances for circuit-breakers from 3 to 30 kV.). The omission is understandable when it is recalled that, not only are chance reductions in clearance almost impossible, but also that the necessary clearance adjacent to the contacts varies very widely with different designs of oil circuit-breaker contacts.

At voltages below 33 kV. the spacings necessary to avoid corona are small. Above this voltage, corona will occur unless large clearances are used or the metal surfaces specially shaped.

With increasing voltage the problem becomes more important, as small increases in dimensions may appreciably influence costs. As an example, if a 110 kV. circuit-breaker equipped with three separate circular tanks required 2 050 gallons of oil per breaker, an increase of the clearance from the fixed contact to the tank side by 1 in. would mean the addition of 140 gal. of oil.

The theory of oil breakdown has received considerable attention by many investigators. The problem is a complex one, however, and no quantitative experimental laws exist which are generally accepted. The impression obtained by a perusal of the published data on oil is one of uncertainty, created by the diversity of opinions and the apparent discrepancy between test results. When considering the possible variations in testing methods alone, such a condition is unavoidable. Apart from the varying electrode shapes, spacings and methods of voltage measurement, the quality of the oil itself and the quantity and type of impurities it contains alone can account for many fluctuations.

Most of the work of investigation has been carried out at comparatively small electrode spacings. A critical résumé of the information available up to 1928, together with tests taken by the British Electrical and Allied Industries Research Association, is given by Whitehead. When considering oil clearances for circuit-breakers, information is required on the behaviour of oil at large electrode spacing. There would appear to be only two papers in English on this subject, one by Minor and one by Goodlet, Edwards and Perry. Minor gives a series of values taken between $\frac{1}{2}$ in. and 1 in. diameter rods at 3 min. and 10 min. periods respectively, with spacings up to 18 in. (Fig. 132.) Goodlet, Edwards and Perry have provided a graph showing the breakdown of medium quality oil (35 to 45 kV. on the B.S.I. gap) at gap spacings up to 24 in. The electrodes were a 12.5 cm. diameter sphere to plane and a point to plane. (Fig. 133.)

This information is of distinct value in determining commercial clearances. It must, however, be used with caution. Both series of tests were taken in a tank of insulating material and the electrodes in each case were of regular shape, thus providing a known field form. Such conditions are impossible in a circuit-breaker where the tank, operating mechanism, etc., are one electrode, and the complete fixed and moving contact assembly

the other. Before giving definitely recommended dimensions for circuit-breaker clearances, it is desirable first to consider the conditions to be met and the methods adopted to obtain economical arrangements.

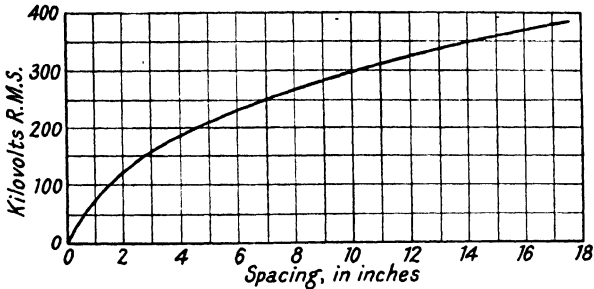

FIG. 132. BREAKDOWN VOLTAGE—TEN MINUTES HOLD ONE INCH DIAMETER RODS

(From a paper by Minor, J.A.I.E.E. April, 1927)

Corona in oil follows somewhat similar rules to those which apply in air. Its behaviour is, however, more uncertain and is at times erratic. It makes its appearance suddenly and

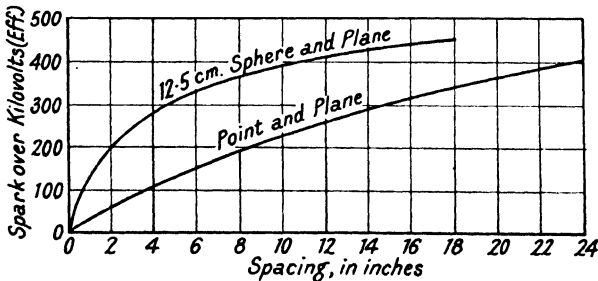

FIG. 133. BREAKDOWN OF MEDIUM QUALITY OIL

(From a paper by Goodlet, Edwards, and Perry, J.I.E.E., Vol. 69)

quickly develops into a viscous state, sending out long streamers. The value at which corona forms in oil is higher than that in air, as its dielectric constant is from 2.5 to 2.6.

The rapid development of a discharge would appear to indicate that the ionized gas generated by the first spark is quickly supplemented by collision ionization. Furthermore, although the viscous nature of the oil will tend to baffle the

extension of the streamers, it will also retard movement from mutual repulsion, thereby causing local concentration.

Discharges are likely to occur at situations where live metal, oil and a solid dielectric meet, the difference in the dielectric constant of the two dielectrics causing field concentration. Such discharges, known as *creeping sparks*, have a strong tendency to adhere to the surface of the solid insulation, and in most cases will attack such surfaces. The tracks of the streamers form an irregular pattern not unlike the branches of a tree in shape. Many of the paper and wood products are particularly affected, as the tracks once made are conductive and enable the streamers to extend their activities further. Porcelain is the best commercial material to withstand this action, as the tracks are not conductive. With heavy discharges however, it will crack from local heating. It will be apparent from the above that corona formation must be prevented.

The different conditions in oil when compared with air may cause what would appear at first to be incorrect test results. As an instance, a particular design of contact lifting rod when pressure tested in air satisfactorily stood 420 kV. for 5 min. When tested in oil, breakdown along the surface occurred in 30 sec. at 364 kV. This failure was caused by excessive field concentration at the contact end. The trouble was entirely removed by fitting a metal stress distributor, which incidentally reduced the clearance from live metal to earth by 6 in.

From this example it will be appreciated that unless correct conditions prevail no defined clearance dimension is of use. Clearances are directly affected by dielectric field forms, voltage gradients and dielectric constants. They can be varied by the use of stress distributors, corona shields and voltage distribution liners, all of which will be dealt with later.

Before determining the clearances for any particular case, certain data must be available. The test voltage which is to be applied to the completed breaker is of first importance. In England and America this test pressure is usually two and a quarter times line voltage plus 2 000 volts. (B.S.S. No. 116—1929 and A.I.E.E. Standard No. 19.) To ensure compliance with this test, a margin of tolerance is necessary. This being merely a factor of safety on a safety factor, its value should be low. It should cover inaccuracy in manufacture and variations in oil breakdown value. The safety factor used by different engineers will naturally vary. A value of 5 per cent is suggested

as the low limit. The second point is to consider the internal dimensions that are governed by breaking capacity. If open contacts are used, the head of oil above the contacts and the clearance between the fixed contact and the tank side may be greater than would be dictated by dielectric stability. The fitting of arc control type of contacts usually enables smaller clearances to be used.

Corona Shields and Stress Distributors. Where sharp points on live parts are unavoidable, corona can be prevented by

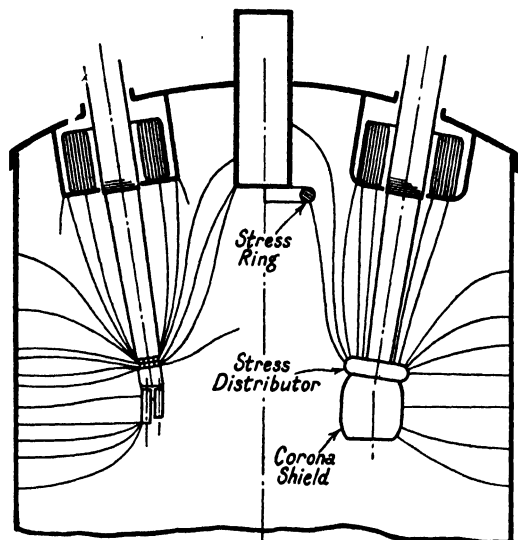

FIG. 134. THE MODIFICATION TO THE DIELECTRIC FIELD IN AN OIL CIRCUIT BREAKER BY THE ADDITION OF SHIELDS, ETC.

shrouding the section involved in an enclosure so shaped that all edges are covered by a shield of round contour. This shield, which should be electrically connected to the section it is protecting, modifies the field form and prevents concentration. Fig. 134 illustrates such an example.

In certain cases the shrouding of points is not sufficient to effect the necessary reduction in clearance dimensions. In such cases a modification of the complete dielectric field can be obtained by fitting stress distributors. These may be of various kinds. A circular plate fitted with a curved rim of defined radius is used both in air and oil, and an example of its use is

on bushing insulators, as illustrated in Fig. 135. In many cases a shield of this form with unbroken surface is impracticable, and stress rings or cylinders are then employed in their stead. An example is that of a moving contact, where the additional oil resistance obtained by adding a complete shroud would seriously reduce the opening speed of the breaker. Fig. 136 shows a stress ring fitted to a moving contact. The ring shown

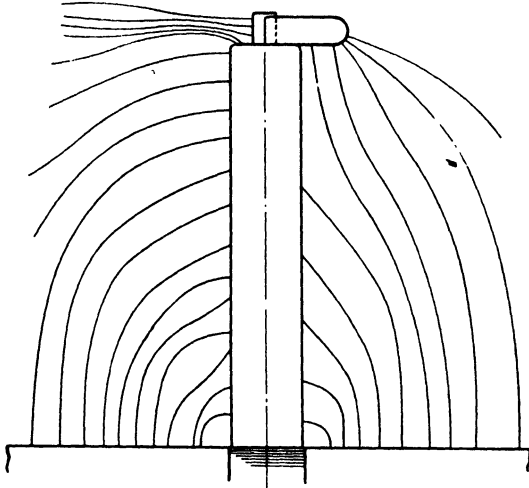

FIG. 135. THE MODIFICATION TO THE DIELECTRIC FIELD OF A BUSHING INSULATOR BY THE ADDITION OF A STRESS DISTRIBUTOR

is of the shape dictated by classical theory, but is not necessarily the best arrangement. Although it may sound paradoxical, the breakdown voltage between needle points increases as the angle of the point is reduced. This peculiar condition has been known for many years, but little practical use has been made of the knowledge. The phenomenon can be explained by considering the dielectric field form produced between a point and plate electrode. In theory the point can be made so fine that it can accommodate one dielectric line of force, in which case all other lines must then spring from the sides of the point. It has already been explained that all dielectric field lines must leave an electrode at 90° to the surface. This being so, the smaller the angle of the point the further will the field be extended. This is made clear in Fig. 137.

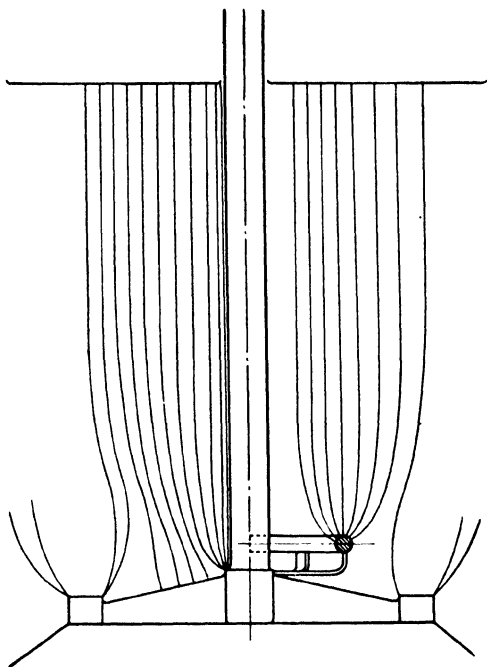

FIG. 136. THE MODIFICATION TO THE DIELECTRIC FIELD OF AN OIL CIRCUIT-BREAKER MOVING CONTACT BY THE ADDITION OF A STRESS RING

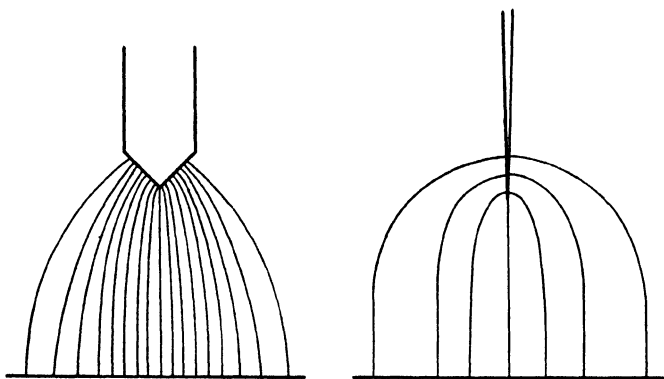

FIG. 137. FIELD FORM AROUND WIDE AND NARROW ANGLE NEEDLE POINTS

The same conditions prevail with sharp-edged cylinders. Fig. 138 shows a test set up to demonstrate this fact. The spacing from the cylinder to the earth plate was 15 in.; spark-over occurred along the path indicated at 435 kV., the arc length



FIG. 138. SPARK-OVER TEST ON SHARP-EDGED CYLINDER
(From a paper by Goodlet, Edwards, and Perry)

being approximately 30 in. Sharp-edged stress distributors of cylindrical or other similar shapes have been used with success in circuit-breakers, instead of the shape shown in Fig. 136.

An alternative type of shield used on the continent of Europe is similar in shape to Fig. 136, but includes an insulation covering which embraces the whole metalwork. By this means the desired modification in the field form is obtained, likelihood of

corona is reduced, and the reduction in the clearance caused by adding the distributor is compensated to some extent by the additional insulation.

Insulation Barriers. The judicious use of solid insulation barriers between live metal and earth is a further method of reducing clearances. This principle is dealt with in Chapter X in connection with oil-filled bushings, which also gives equation (80), controlling the design of dielectrics in series. Apart from evenly distributing the voltage gradient in the oil, these barriers also prevent the lining up of moisture and dirt chains, thereby considerably increasing reliability.

Bakelite tubes make the best cylindrical barriers up to approximately 12 in. in diameter. They are strong both electrically and mechanically, easy to fix, and can be made accurately to dimensions. As the distance from live metal increases, small inaccuracies are unimportant, and barriers made from dried and varnished fullerboard are more economical. The joint may be made by overlapping and lacing with cord. The varnishing of the fullerboard is to prevent moisture absorption.

Oil. In the design stage, the strength of oil should be taken as that represented by "medium quality," which has an effective value of 35 to 45 kV. on the B.S.I. gap. It must, however, be realized that in service there will be occasions when oil with a lower strength than this will be in use in the circuit-breaker.

The reduction in the breakdown value of oil is due entirely to the presence of impurities, but the effect which such impurities have upon the strength of the oil is somewhat complex. For instance, their activity in this direction is controlled to some extent by the shape of the electrodes which the oil surrounds.

Peek states that, at small spacings, the dielectric strength of oil is reduced 30 per cent if water is present in so small a proportion as one to 10 000 parts of oil. Goodlet shows that at large spacings and with point-to-plate electrodes the breakdown voltage is independent of the quality of the oil; whilst with a 12.5 cm. sphere and plate electrodes the breakdown voltage varies directly as the quality of the oil.

In the case of the sphere-to-plate electrode, the effect may be explained by the fact that impurities are attracted by the field and that their presence there distorts that field. Any distortion of a regular field will result in a greater electrical

stress at the point of distortion than would exist otherwise. Hence, the greater the number of such points of distortion between, or in the vicinity of, a pair of sphere plate electrodes, the greater the total field distortion and the greater the stress for a given voltage. In other words, the greater the number of impurities present, the lower the breakdown value. The number of impurities present in a given quantity of oil is clearly an inverse measure of its quality. Furthermore, there is a tendency for the impurities to arrange themselves along the lines of force of the field, and by so doing to provide a relatively low resistance chain between the electrodes. This effect is more pronounced at the smaller spacings. No doubt if the impurities can make continuous chains, there is less field distortion than when they are promiscuously arranged, but the lesser field distortion is more than counterbalanced by the effect of the continuous conductive path provided.

The theory of the point-to-plate gap is rather more involved, but some idea as to why the breakdown voltage is unaffected by the quality of the oil may be obtained from the following explanation.

The field intensity between the point and plate is very irregular, and perhaps 90 per cent of the total stress takes place across a tenth of the total gap adjacent to the point. Thus, when the voltage of the point is raised, the oil in the immediate vicinity is highly stressed and will eventually break down, giving rise to local discharge. The impurities can have little, if any, effect in this case, since the field is so highly concentrated about the point that impurities would require to be present in large measure to cause any appreciable distortion. It is therefore the oil about the point that breaks down and allows streamers to spread out from the point. The voltage at the far end of these streamers is practically the same as that of the point. Hence, momentarily, the stress across the oil between the streamer end and the plate is increased, and the further out the streamer spreads the greater is this increase, because the voltage across the gap is, at this instant, across a portion represented by streamer end and plate.

As the voltage of the point is increased the streamers will become longer, and the highly-charged oil about the point will act as an expanding sphere and further the action. Ultimately a streamer will result of sufficient length to give a stress across the remaining part of the oil in the gap, which stress will

break down the oil whatever its strength may be. Thus the complete gap has discharged more or less unaffected by the impurities present.

The formation of the impurities into continuous chains is prevented in the case of the point plate electrode by the turbulence created by the strong discharge action of the point.

Actually, the fact that the breakdown voltage between needles is unaffected by oil quality is of little practical importance in circuit-breaker design. The spacings required for needle point electrodes are greater than those necessary for rounded surface electrodes in normal quality oil. Furthermore, corona commences from sharp points at voltages much lower than the breakdown voltage of the gap. As an instance, a needle-to-plate gap of 15 in. having a breakdown voltage of 150 kV. will commence to discharge at approximately 75 kV.

Recommended Oil Clearances. Design clearances, therefore, are based on the assumption that proper use has been made of corona shields and stress distributors, and that the oil will be maintained at medium quality. Curve *A*, Fig. 139, gives recommended clearances under such conditions. Curve *B* shows the order of reduction that can be obtained by using a number of insulation barriers to improve the voltage gradient, in addition to shields and stress distributors.

Impurities in Oil. The impurities present in outdoor circuit-breaker oil differ in degree from those met with in indoor circuit-breakers. As impurities have a direct bearing on clearances, they are worthy of some consideration. Experience has proved that it is impossible entirely to prevent the ingress of water into the oil of outdoor circuit-breakers, such water being of doubtful purity. Provided reasonable care has been exercised in making watertight joints at all covers and between the tanks and tops, ingress will be slow. The principal contribution would then be obtained from condensation. Much of this water settles at the bottom of the tank under the action of gravity. It is not unusual to find an appreciable quantity of water at the bottom of a circuit-breaker tank that has been in service for some time. This settled water does not affect the efficient operation of the breaker provided that solid insulation is kept above the maximum water level. The drop in breakdown voltage caused by pure water is not excessive. Its effect on other impurities that may be present is, however, considerable.

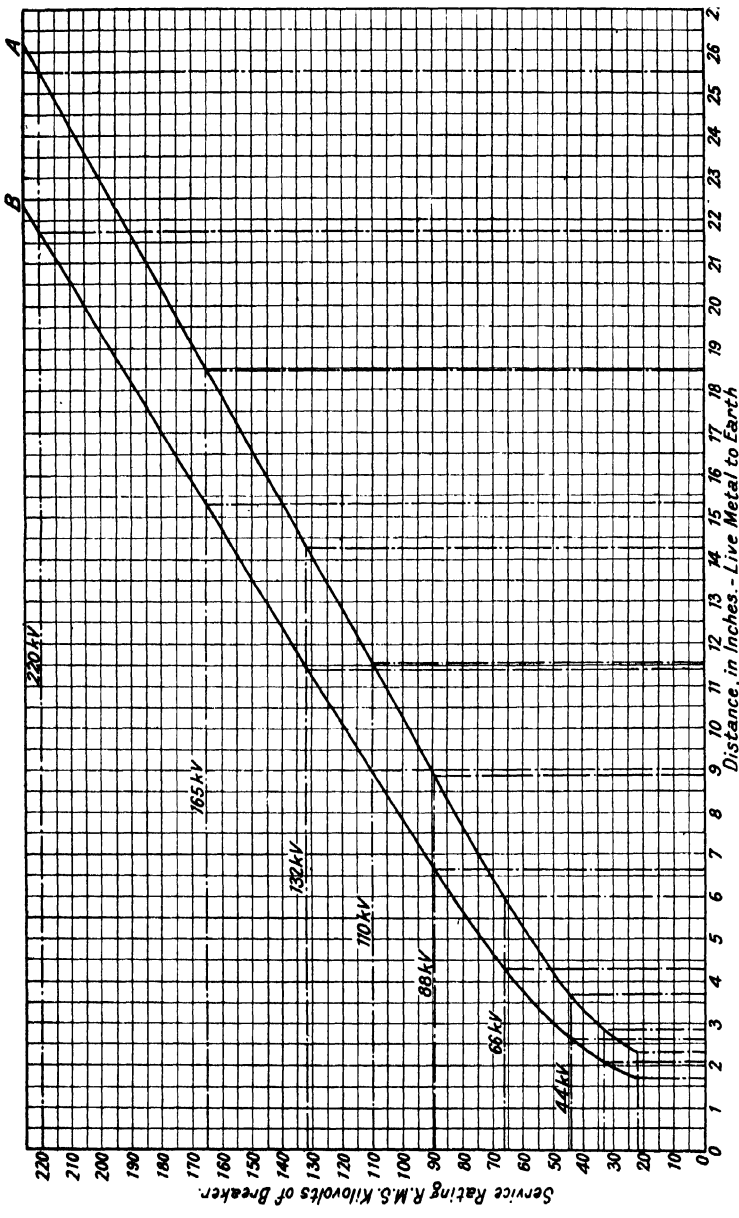

FIG. 139. RECOMMENDED OIL CLEARANCES FOR OIL CIRCUIT-BREAKERS
 (Assuming a one minute pressure test of 2.25 times rated voltage plus 2 000 V.)

Tests taken by the British Electrical and Allied Industries Research Association show that cotton or pressboard fibres have no great effect upon dry oil, the drop in the breakdown voltage being approximately 30 per cent. When, however, the same quantity of fibres was added to oil containing moisture, the drop in the breakdown voltage was approximately 90 per cent. In the case of dry oil the fibres have a fairly high electric strength, and their detrimental effect on the breakdown voltage will be caused by flux concentration due to the difference in the relative dielectric constants. When water is present in the oil, the fibres act as storage for this moisture and become conductors. They also increase the amount of moisture that can be held in suspension. Furthermore, the addition of this moisture to the fibres aids their movement in the dielectric field, due to the fact that they now have a relatively high electrostatic capacity.

Most impurities are porous and will be affected in a similar way to the fibres mentioned.

Low breakdown voltage, therefore, is caused by the combination of solid impurities and water. As already stated, it is impossible to prevent the ingress of water. It is, however, possible to extract solids by the use of oil-purifying apparatus, and many schemes have such equipments permanently installed with an oil piping system connected to all circuit-breakers. In cases where heavy load breaking is rare, oil has been known to keep in a satisfactory condition for several years.

With the opening of a circuit-breaker under load, a further impurity—carbon—is introduced. In small quantities carbon does not seriously affect breakdown voltage. In circuit-breakers controlling the higher voltages, the quantities of oil used are large, and the currents to be broken small. Therefore the proportion of carbon to oil is less than that experienced with low voltages. In cases where heavy breaking duties have been imposed upon a circuit-breaker, the liberation of carbon may be excessive. As, however, an inspection of the contacts will be necessary after such duty, the purification of the oil can be carried out at the same time.

Surface Creepage Distances. The first consideration when designing solid insulation for oil immersion is the prevention of corona at its surface. This can only be done by designing so that field concentration is avoided. The use of stress distributors for this purpose has already been explained. It is

fortunate that careful examination after a voltage pressure test will usually reveal the tell-tale spark tracks even after a one minute test.

It is sometimes necessary to arrange insulation in such a manner that it is only partially immersed in oil. A contact lifting-rod is an example of this. In these instances excessive stress may be concentrated along the portion in air due to the different values of κ for air and oil, and breakdown occurs although the creepage distance in oil alone would be adequate. In such a case the insulation may be shortened until the whole length is oil immersed. Where this procedure is impossible, the stress in the air must be kept within a safe figure.

The following values are given as a general guide. Assuming reasonable dielectric field formation, a test value of 22 kV. per in. of creepage surface may be taken as a safe figure for porcelain, bakelite or similar insulation. Where the voltage distribution along the surface is controlled as in a condenser bushing the value may be increased to 27 kV. per in.

CONTACT LIFTING MECHANISMS

The mechanism for bringing the circuit-breaker contacts from the open into the closed position is first of all governed by the general design of the circuit-breaker. It may vary between the complicated mechanisms of an oil-piston type for automatic reclose, and the simplest wire rope type that might be used in the ordinary vertical break circuit-breakers, and which is described later.

So much depends on individual design that it is impossible to cover all types, but the main features of all these mechanisms are—

(1) That the moving contact shall follow a straight line throughout the whole of its travel.

(2) That the necessary strength of parts shall be obtained with the minimum of materials.

(3) That the greatest speed of operation shall be attained with the limited forces acting.

(4) That vibration and recoil shall be as small as possible.

(5) That the load curve shall be as nearly as possible coincident with the performance curve of the closing power unit.

The requirement (1) is obtained either indirectly by the

suitable disposition of levers, or directly by the use of a flexible drive such as the Arens rod.

Point (2) is really one that applies to all mechanisms: in some it is essential, although in others it is not so. In the case of the contact operating mechanism, it is desirable in so far that the smaller the mass to be moved, the greater the acceleration with a given mechanism; and the greater the acceleration, the higher the speed of contact separation. Also, the smaller the mass, the less the duty on the closing mechanism and therefore the less the call for power for the operation of the circuit-breakers.

Point (3) arises from the fact that the higher the speed of contact separation, the greater the breaking capacity, other things being the same. This feature has been dealt with in Chapter VIII.

The absence of vibration and recoil in point (4) is almost self-explanatory. Vibration tends to cause a mechanism to stick, and recoil may result in the arc gap being reduced to a value small enough to cause arc re-establishment.

The essence of point (5) is that, if the load curve of the contact operating mechanism is above that of the closing mechanism, the latter will not close the breaker. On the other hand, if the curve for the closing mechanism is very much above that of the operating mechanism, the breaker will be closed too violently.

It is not necessary that the load curve of the operating mechanism should be regular in form. Indeed it is almost certain that it will not be so, due to the fact that a sudden increase in load is bound to occur when the contacts meet. Although this increase may be modified by the use of toggles in the lever mechanism, it is very unlikely that the result will make the load curve quite regular. In general, therefore, the load curve will tend to increase towards the end of the closing stroke, and this tendency will be accentuated by the fact that all accelerating or throw-off springs will be tending towards their maximum loading at this time. An example load curve for a lever and toggle mechanism is shown in Fig. 140.

It is a fortunate chance that the characteristic curve of a solenoid-type closing mechanism is of the same general form as that of the load curve of most contact-operating mechanisms. This is because the pull on the solenoid plunger rapidly increases as the air-gap decreases. With a motor operated type

of closing mechanism, the curves are not the same either in shape or slope. Thus, to consider the centrifugal type of motor-closing mechanism, it must be admitted that this has a speed-torque characteristic which falls with increase of speed, and therefore exhibits a curve that is opposite in this respect to the load curve of the contact mechanism. How these two apparently ill-sorted features are made to produce an efficient result is explained by the fact that energy is stored in the revolving weights of the centrifugal mechanism when the torque

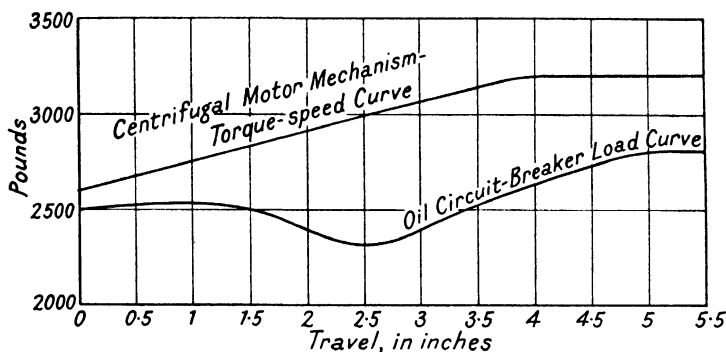

FIG. 140. CURVES OF LOADS ON MECHANISM AND OIL CIRCUIT-BREAKER

is high, and the contact mechanism load is small, and this energy is returned to aid the motor mechanism when the torque of the latter is small and the contact mechanism load is high. Thus the combined effort of motor and centrifugal mechanism is flexible and has a characteristic curve that is able to conform to the shape of the load curve of the contact mechanism. Even so, whenever it is required to design a contact-operating mechanism that it is known will be operated by a motor-closing mechanism, every effort should be made to avoid sharp peaks in the load curve of the operating mechanisms.

As has been already stated, it is impossible to describe all kinds of contact-operating mechanisms, but there is no reason why the design of two or three different types should not be chosen to indicate the general nature of the problem.

Lever and Toggle Mechanism. For this purpose let us consider the design of the lever and toggle mechanism. This is shown in single line diagram in Fig. 141. The horizontal pull P is that which has to be transferred to the main closing

234 OUTDOOR HIGH VOLTAGE SWITCHGEAR

mechanism, and will be determined by the relation between the contact bedding forces, etc., and the lever system employed. There are two fixed fulcrum points, one at *A* and the other at *B*, and one sliding fulcrum point at *C*. The fulcrum *A* is in the nature of a trunnion bearing with space for the contact-lifting

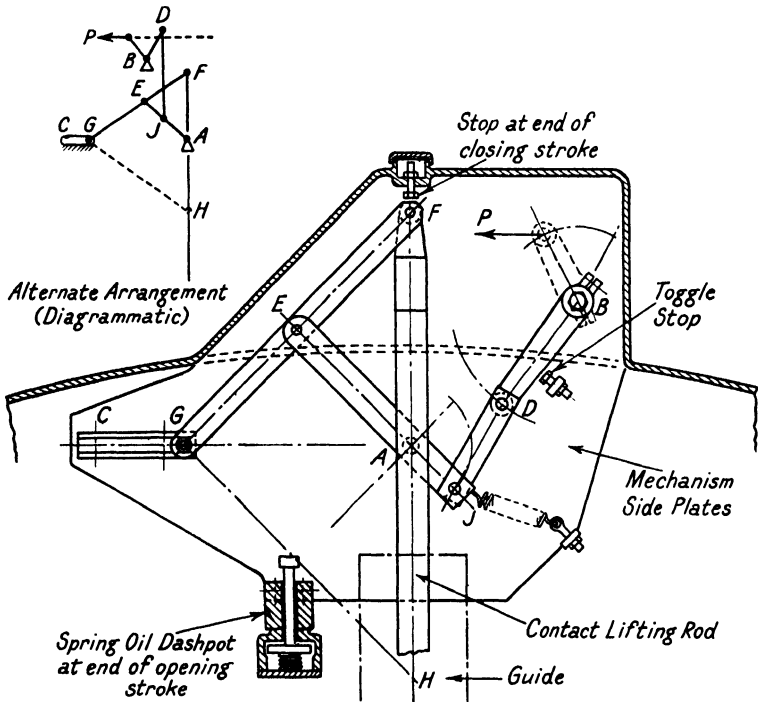

FIG. 141. CONTACT LIFTING MECHANISM

rod *FH* to pass freely between. Sometimes a link pivoted at one end is used in place of the sliding bearing *C*, but the free end of this link describes an arc during its travel, and this departure from the horizontal results in vibration of the moving contact-lifting rod. The proportions of the levers are such that true vertical travel is obtained. Thus the arm *AE* is equal in length to the arms *EF* and *EG*. Furthermore, the arm *AE* is perpendicular to lever *FG* when the mechanism is in either the fully closed or fully open position. With these conditions, it can be proved by simple geometry that the travel of the end

F of the lever FG will lie on a straight line. The end G is made to oscillate in the sliding bearing of C , which bearing must be in the same horizontal line with A .

Suppose the weight of the moving contact to be 60 lb. and the total bedding forces 330 lb. Then the maximum vertical load on the contact-lifting rod will be 390 lb. To obtain a force of 390 lb. along FH , the force along GF must be equal to $390/\cos 45^\circ = 550$ lb. This force is obtained along GF by the turning effort of the lever AE about the centre A . It should be noted that the maximum result is obtained from the turning moment of lever AE , by the fact that the lever GH is perpendicular to AE when in the position of maximum load on FH . The moment required at E to give 550 lb. along GF is $550 \times 15 = 8\,250$ lb. in., and from this is obtained the perpendicular force necessary at the end J of lever AJ . In the present example the latter force is $8\,250/6 = 1\,375$ lb. This will represent the force required along the lever DJ , if the latter is acting in the position of maximum efficiency; which is along a line perpendicular to AJ . If the arm DJ does not act perpendicularly to AJ , but is inclined from it by some angle ϕ , then the force required along DJ will be $1\,375/\cos \phi$. For instance, suppose the arm DJ made an angle of 15° to the perpendicular at J . Then the force required along DJ to produce the moment of 8 250 lb. in. about A would be $8\,250/6 \cos 15^\circ = 1\,480$ lb. To produce a force of 1 375 lb. along DJ requires that the turning moment of BD about the fulcrum B shall be equal to $1\,375 \times 1.5 = 2\,220$ lb. in., and this is the torque that the toggle has to give about B . It is easy from this to obtain the figure $2\,220/6 = 370$ lb., which is the pull required along the pole interconnecting rod in the direction of P .

In this position the toggle is exerting its maximum effort, and the various members are subject to their highest load stress. They can therefore be designed for strength on this load value. If a graph be plotted for the pull at P against mechanism travel, a load curve will result, and for the example given above this load curve is shown in Fig. 140. From this it will be seen that, in spite of the fact that the toggle reaches its maximum effort at the end of the travel, there is still a decided peak at this point in the load curve. In this example, it is because the contact-bedding pressure increases more rapidly than does the advantage of the toggle.

The circuit-breaker fitted with the contact-lifting mechanism just considered was closed by a motor-operated centrifugal mechanism, and the torque speed curve of this is also shown in Fig. 140. It should be noted how well the two curves agree, because the closing action of the circuit-breaker which they represent was very efficient, and this was due largely to the close agreement between load and operating curves.

In the design of the contact mechanism, the stresses set up by impact are to be included with those obtained for the steady condition as given above. Such impact occurs during both opening and closing of the contacts, and will be greater or less according to the type of circuit-breaker involved. Too great an impact on closing may cause overtravel and consequent damage to the contacts. To avoid this, an overtravel stop or buffer should be fitted; preferably to act at the end of the contact rod. The possibility of trouble due to overtravel, etc., is more likely in automatically-operated circuit-breakers than in manually-operated breakers. The impacts set up by the violent opening of the breaker under, say, short-circuit conditions are also controlled by dashpots. In any case, it is clear that the stresses from impact must be provided against when designing the various levers. The actual design of the mechanism parts and the calculation for the stresses to be sustained by them are purely mechanical engineering problems, and will not be treated here, but the following points may be of help in the general design.

The position of the toggle might be on the opposite side of the pin *A*, Fig. 141. This would result in a smaller stress on the pin *A*. The amount of toggle should be considered carefully in view of the fact that the greater the amount of toggle, the quicker will be the action of the mechanism. High bearing pressure on the toggle joints is generally unavoidable, and consequently it is sometimes necessary to introduce roller or ball bearings at these points to minimize the loss due to friction.

It is good practice not to use steel pins at the joints; particularly at those link joints that are subject to high bearing pressure. The bearing *A* in Fig. 141 is an example of this. When the bearing and the pin are both of ferrous metal, there is a good chance that the two surfaces will seize up due to the action of the oxygen on the iron. It must be remembered that these mechanisms may stand for a considerable time without operation, and during that time the lubricant that may have

been there at the beginning may have lost its properties or have run out. The bearing, then, should be lined with a bronze bush or, better still perhaps, a bronze pin should be used. It is possible to obtain high tensile bronze with an ultimate strength of 35 tons, and so the strength of steel may be obtained with the chemical inertness of the bronze. Such a pin in a steel bearing will avoid the trouble mentioned above, since the steel and bronze surfaces will not bind during periods of inaction.

Rack and Pinion Mechanism. Another contact-lifting mechanism is the rack and pinion type. With this, one end of a toothed rack is coupled through an insulated rod to the moving contact. The rack engages with a pinion, the revolution of which lowers or raises the rack as the case may be. There is necessarily a pinion for each single-pole breaker unit, and the three pinions of a triple-pole breaker are mounted on a common shaft. This shaft can be operated through reduction gears by a motor for electrical closing, or it may be operated through levers by a solenoid. Between the closing mechanism and the common shaft a catch or tripping device can be introduced, upon the operation of which the rack and attached contacts are allowed to fall freely for the opening of the circuit-breaker. Very rapid opening can be obtained with this type of mechanism, particularly if accelerating springs are used in addition. It is, however, very important to ensure that the common operating shaft is of sufficient torsional rigidity to prevent the least deflection. With very high-voltage breakers the distance between the three poles will be considerable, and yet this common shaft must transmit the closing effort throughout this length without distortion. If twist should occur along the shaft during operation, the result would be that the breaker pole nearest the operating mechanism would close first and the other two poles second and third respectively. It is possible to design for an adjustment in the rack and pinion device to correct for inaccuracies in alignment due to shaft deflection.

A disadvantage with this type of operating mechanism, when used with double-break circuit-breakers, is that when the breaker is closed the rack will be sticking up above the pinion by an amount equal to the travel of the contacts. In the case of high-voltage breakers this distance may well be of the order of 3 ft. or more. This means that a pocket must be provided in the tank top to accommodate the rack when the breaker is closed. This pocket will be a vertical protuberance between

the bushings of the circuit-breaker, and provision must be made to maintain the required clearance from the line end of the bushings to grounded metal. This can be achieved by making the bushings sufficiently long, or by setting them at a

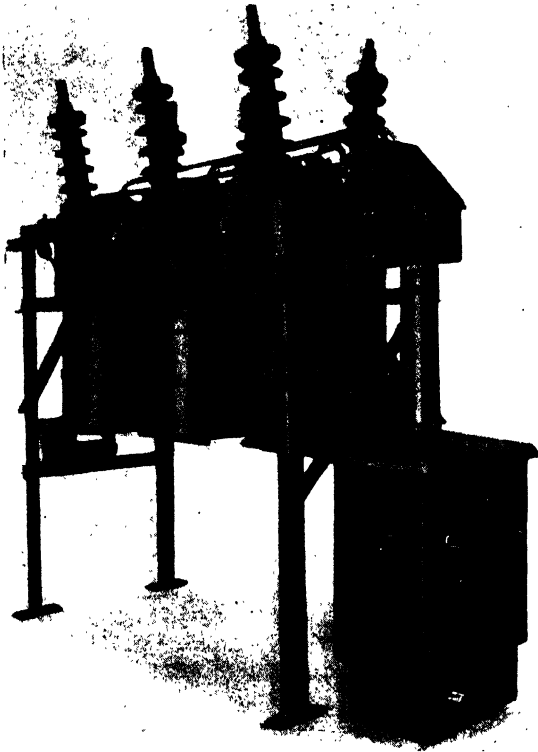

FIG. 142. 33 kV. OUTDOOR OIL CIRCUIT-BREAKER WITH "ARENS"
ROD OPERATION
(Metropolitan-Vickers Elec. Co.)

greater angle to the vertical. This drawback is not present in circuit-breakers of the multiple break type, since the actual travel of the rack is the corresponding fraction of the total break.

Arens Control Mechanism. A third type of contact-operating mechanism represents the application of the Arens control to this purpose. This is a patent device for the transmission of power by means of a flexible rod, and functions on the same

principle as the bowden wire. The Arens rod is, however, reversible in its action, in so far that it will act in either tension or compression. In Fig. 142 there is shown an oil circuit-breaker fitted with such a mechanism. The device is bent to the desired shape and the outer case securely clamped to the tank top. Precaution must be taken that this joint is weather-proof. One end of the inner cable is fastened to the moving contact, whilst the other end is connected with the solenoid or motor-closing mechanism. Thus there is a direct coupling between the closing mechanism and circuit-breaker contacts, and all links, levers, shafts and toggles are avoided. This is undoubtedly one of the most direct and simple methods of operating the contacts of an oil circuit-breaker.

There are, of course, points to be considered in the use of the Arens drive, as with the other types of operating mechanisms. The size of cable must be chosen so as to be adequate for the duty assigned to it, and the jointing of the cable end to the mechanism end must be thoroughly made, with no risk of slipping. The best method for the latter purpose is to swage the end of the cable into a member suitable for attachment to the contact or mechanism. If these points are duly observed, no fear need be entertained that the cable will stretch. Tests have been carried out, and prove that with prolonged use the extension of the steel cable is quite negligible.

This contact-lifting device provides the further advantages that there are few parts to go wrong, and adjustment for length of travel can easily be made. The inertia of moving parts is reduced to a minimum, and in consequence the speed of opening of the breaker is higher when compared with a lever system mechanism. Again, the air chamber at the top of each breaker tank can be more easily sealed to prevent an interchange of gases between them. The friction in the cable, which has to be included in the design calculations, is kept low by the lubrication provided at each operation of the breaker by oil from the circuit-breaker tanks. This oil creeps up the rod by capillary attraction. In Fig. 143 a curve is shown that gives results from friction tests in both the static and moving conditions. From these tests the coefficient of friction can be calculated from the equation

$$e^{\mu\alpha} = (W + w)/w \quad . \quad . \quad . \quad . \quad . \quad . \quad (71)$$

where μ is the coefficient of friction, and α the angle of lap in radians, W = the load, and w = the friction load. It is

240 OUTDOOR HIGH VOLTAGE SWITCHGEAR

assumed that all the friction occurs at the bends, and upon this assumption the coefficients of friction are found to be as given in the table below.

COEFFICIENTS OF FRICTION ARENS CONTROL

Condition	Temperature	
	20° C.	- 13° C.
Static	0.268	0.279
Moving	0.223	0.196

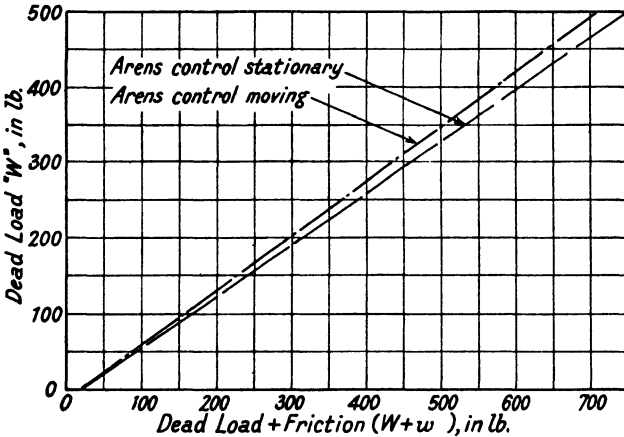

FIG. 143. FRICTION TESTS ON WIRE CONTROLS

DASHPOTS

On the question of dashpots used for absorbing the stored energy during opening of the circuit-breaker, it might be said that there are two main types: the *oil dashpot* and the *spring dashpot*. Whichever type is chosen, the dashpot should be placed so that it acts as nearly as possible on the centre of gravity of the moving mass it is intended to control. In this way the stresses caused by the impact are more evenly distributed throughout the mechanism. This is a small feature that is unfortunately very often overlooked.

The Oil Dashpot. Theoretically, the oil dashpot is more "correct" than the spring dashpot, since it not only absorbs energy but it cannot return it. Any spring, when compressed or elongated, will endeavour to return the energy that has been put into it, and, if it is of a size to absorb the right amount of energy from the moving mass of, say, the contacts and mechanism of a circuit-breaker, the return of this energy will in all probability cause the breaker mechanism to bounce badly. This is a particularly undesirable feature, and one that is not possessed by the oil dashpot.

The oil dashpot is not so elastic as the spring type, and for very sudden impacts becomes almost solid. To an extent this can be controlled by the size of the oil vent hole or by the relative shape of piston and cylinder, but it is not possible to obtain quite the same elasticity with oil as with a spring. A weakness of the oil type that involves a vent hole, is the possibility of this hole becoming blocked. This trouble would not prevent correct operation of the dashpot if it were full of oil, since it is unlikely that the obstruction would withstand the high pressure set up in the oil by the impact; but if the blockage occurred after the breaker had opened, it would prevent oil filling the dashpot again, and therefore, on the next occasion of the breaker opening, there would be no oil to receive the impact, and the mechanism would be subject to the full shock of the direct impact. The oil dashpot of the converging cylinder bore type is free from this disadvantage.

The Spring Buffer. The main difficulty with the spring type buffer is to design the spring so that it will absorb the right amount of energy, yet when in the quiescent state will not support the mechanism. Also it must not cause excessive bouncing. Dashpot springs that are too strong will prevent the circuit-breaker attaining its full opening travel, except for the brief period during which they are compressed by the impact load. Of course it may be argued that the full travel is only required during this short time, in which case the strong spring is admirable. Springs that will not absorb enough of the kinetic energy of the moving contact are of little or no use, since there is a good chance that they will be smashed by the impact, and in any case will not give the required buffer action. The spring dashpot will help the closing of the circuit-breaker by virtue of the fact that in the open position of the breaker it is exerting a pressure in the closing direction.

The Oil-Spring Dashpot. Perhaps the most successful dashpot is a combination of the oil and spring types. With this design, the springs are generally arranged to come into action first, and to reduce the velocity of the moving mass. Later, the oil dashpot engages and acts as a damping device, not only to the remaining momentum in the moving contact but also to the time constant of the springs, and so prevents their too sudden recoil. In this way the bouncing of the mechanism is considerably reduced. An example of such an arrangement is shown in Fig. 141.

OPERATING MECHANISMS FOR OIL CIRCUIT-BREAKERS

The operating mechanism for breakers of 33 kV. and above is in most cases an independent unit which is connected to the breaker by means of connecting rods and bell crank levers. This construction has several advantages, viz. the design is not complicated by the inclusion of contact lifting levers; the complete unit can be self-contained in its own box and arranged for floor or low frame mounting, thus rendering it easily accessible from ground level; and the same mechanism can be used for a range of different size breakers.

The electrical requirements are generally similar to those that have proved necessary for the lower voltage range of breakers, a brief summary of which is given below.

The breaker should have a *trip free* or *free handle* feature. The term "free handle" was obviously coined for a hand-operated breaker. It has since been applied to all mechanisms irrespective of the motive force operating them. The requirement means that the portion of the mechanism connected to the closing power unit must not be permanently coupled to the breaker. The mechanism must therefore have two sections; one directly coupled to the breaker called the *fixed* portion, and one directly connected to the power unit called the *free* portion. The tie between these two sections is made by the tripping feature. Thus, when the trip coil operates, it disconnects the two sections and leaves the section permanently fixed to the breaker free to move independently of the other section.

The reason for this requirement is to prevent a breaker being held in on a fault by the closing section of the mechanism.

When breakers are closed by a power unit such as a solenoid

or motor, arrangements must be made to introduce hand closing in case of necessity. Where necessary, the tripping mechanism must be so designed that it can be operated by relatively low-powered trip coils. An example of such a case is when the output of bushing transformers, incorporated in the breaker, has to operate overload coils situated in the mechanism.

The mechanical construction is, however, influenced by out-of-door mounting. Indoor mechanisms are protected from dirt, damp and extremes of temperature change, whereas outdoor mechanisms have to operate under these adverse conditions. Maintenance and adjustment of indoor gear can be carried out in comparative comfort, whereas work on out-door apparatus may have to be done under severe weather conditions.

For these reasons there are several requirements which should be complied with no matter what type or design of mechanism is contemplated.

Dirt and Damp. The first requirement to counter dirt and damp is to provide an efficient mechanism box, or housing, which is rainproof and which will discourage condensation. Condensation is cured by good ventilation. In extreme cases the inside of the mechanism box should be painted with a cork paint similar to that used in ships for the same purpose. The mechanism itself cannot, however, be treated in this way. Another alternative is to install a small heater inside the box to raise the inside temperature slightly. In practice this has proved unnecessary except in extreme cases. It has, however, an additional advantage where low temperatures are experienced in that it reduces the delay in operating time caused by oil thickening.

Doors or removable covers should, if possible, be of a rain-proof design that dispenses with gaskets, as the latter are inclined to be damaged in operation. This can be accomplished by arranging water traps and rain sheds, Fig. 144.

However good the box, foreign matter will penetrate in certain situations; a good example being where sand storms are encountered. Rain may beat on a mechanism when the door is open, and some measure of condensation is bound to take place. The mechanism itself must therefore be designed accordingly.

Bearings in steel or iron should be bushed with a non-corrosive metal, or, alternatively, the shaft or pin should be made

244 OUTDOOR HIGH VOLTAGE SWITCHGEAR

of non-corrosive metal. This is to prevent sticking due to rusting. For the same reason, steel surfaces that move independently, but remain in contact for certain positions of the mechanism, should be separated by a non-corrosive washer. Levers, links, and catches should be operated by springs in preference to gravity; or, if gravity control must be utilized,

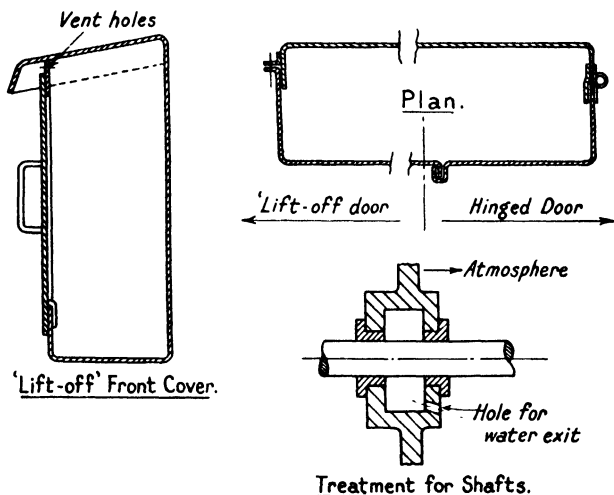

FIG. 144. METHOD OF RAINPROOFING OPERATING MECHANISM HOUSINGS

adequate safety margin must be allowed to overcome sticking. It should also be noted that where light levers and triggers are employed, due precaution must be taken to guard against these becoming clogged with grease and dirt, particularly as low temperatures will tend to congeal grease. Also, it is to be noted that it requires a smaller percentage of corrosion of the metal parts to "stick" a light mechanism than it does for a heavy one.

The doors or covers of the mechanism chamber should be as large as possible in order to give the maximum of accessibility. This makes for ease in the examination and maintenance of auxiliary switches and terminal boards, and in the adjustment of tripping mechanisms. It is very desirable that this should be easily accomplished and checked, since it sometimes happens that work of this nature has to be carried out in bad weather. It is a decided advantage if the wear of parts, such

as trip catches, can be taken up by an adjusting screw. To have to dismantle the mechanism in order to remove a catch for the regrinding of a worn surface is laborious and costly.

Some other points are that the principle of the mechanism should be easy to follow, the number of parts kept to a minimum, and no parts hidden from view. Also, the operating motor, solenoid or trip coil should be capable of being removed without upsetting the mechanical setting of the mechanism or circuit-breaker, and liberal room should be allowed for multicore cable glands. Such glands in awkward positions will prevent the cable man from making a good joint. If these several points are observed, ease of maintenance, speed of inspection and general labour saving will result.

Solenoid Operating Mechanisms. The solenoid coil and plunger type of closing mechanism was used on some of the earliest types of oil circuit-breakers. It is still the most popular closing mechanism, which is no doubt due to its reliability and easy action. The solenoid will give directly a straight line pull. It is quick in action, and can be designed to exert considerable force. The straight-line feature of the solenoid simplifies the incorporation of a free-handle action in the mechanism.

The stroke of the plunger is necessarily short, since the pull between plunger and pole piece varies directly as the square of the flux density, and the flux density varies inversely as the reluctance. When the circuit-breaker is in the open position, the air gap of the solenoid is at its maximum length; therefore, considerable force may be required to attract the plunger when it is in this position. It is thus necessary to ensure that sufficient energy is available to start the circuit-breaker on its closing stroke. As the plunger of the solenoid moves along to its "closed" position, the magnetic pull rapidly increases, but due to the fact that the meeting of the oil circuit-breaker contacts occurs towards the end of the stroke, and also that accelerating springs, etc., are being compressed towards their maximum, the closing force required from the plunger will increase accordingly. It has already been mentioned under "Contact Lifting Mechanisms" that the ideal arrangement between lifting mechanism and closing mechanism occurs when the load curve of the former lies just below the operating curve of the latter, and that both curves are of similar form.

In general, a greater expenditure of electrical energy is incurred with the solenoid operating mechanism than with other

types, and therefore a reliable d.c. supply is necessary. Such a supply is usually provided by a storage battery, and, although this battery may be used for other purposes such as emergency lighting, its capital cost and maintenance are charges against the circuit-breaker operation.

The battery in turn introduces the necessity of a charging set, and this generally takes the form of a motor-generator set. On schemes where there are many stations, a portable motor generator set can be used with advantage for bulk charging.

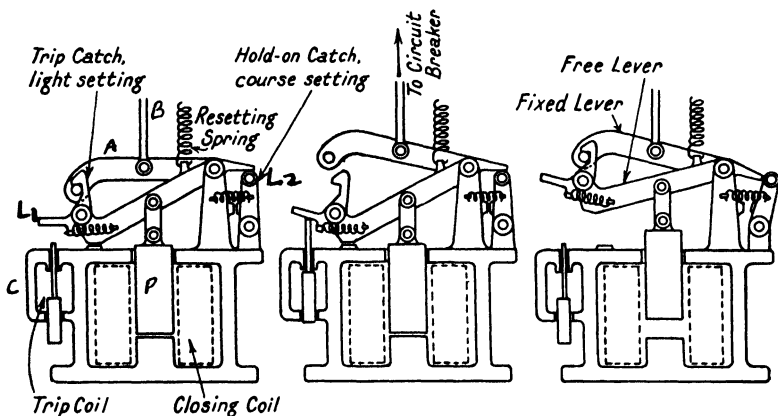

FIG. 145. DIAGRAMMATIC DRAWING OF A FREE-HANDLE SOLENOID-OPERATING MECHANISM

In this case trickle-charging rectifiers are used for normal needs. Of course, both battery and motor generator set can be dispensed with if a rectifier unit of sufficient capacity is installed. A disadvantage of this plan is that, should the rectifier be supplied by the circuit controlled by the oil circuit-breaker, and should this circuit be opened by that circuit-breaker, there will be no power available to reclose the breaker. It is decidedly preferable that the closing and tripping supplies of all high voltage oil circuit-breakers should be from an independent source.

In the design of the solenoid closing mechanism, the chief problem is to secure a mechanically shock-proof yet sensitive arrangement. The force with which the plunger strikes the pole piece gives a bad jar to the whole mechanism, and it is essential that this shall not cause the trip mechanism to operate. On the other hand, the trip mechanism must not be

too hard in or the breaker may fail to open when required. The "free handle" feature, which is now a B.S.I. requirement, *vide* B.S.S. No. 116—1929, aids the solution of this problem, in that tripping mechanism which connects together the fixed and free portions is usually completely reset in the open position of the breaker. The hold-in portion of the mechanism is therefore the only part that has to latch in on the closing stroke, and as the trip mechanism is independent of the hold-in

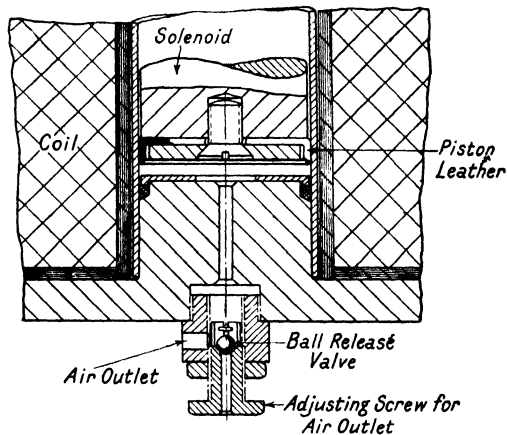

FIG. 146. METHOD OF SHOCK ABSORBING BY MEANS OF AIR DASH-POT

portion there is no need for the latter to have too fine a setting. This is shown diagrammatically in Fig. 145.

In order to reduce the impact on closing, an air dashpot is sometimes fitted, and this is arranged to come into action at the end of the stroke as required. Fig. 146 illustrates such a device fitted to the end of the solenoid plunger.

OPERATING COILS. The pressure used for energizing the operating coils of solenoid mechanisms is generally between 100 and 250 volts. The essence of the coil design should be to obtain the necessary ampere-turns with the minimum current. A design that economizes in copper or iron by the use of large operating currents is not good, since such large currents bring a lot of troubles in their train. In any case, it will be found that the current necessary, even at its lowest value, will be too large for direct manipulation. The usual practice is that the controller mounted on the switchboard shall enable the circuit

to be closed on to the comparatively small operating coil of a contactor. The closing of the contactor, that follows from the energizing of its operating coil, completes the circuit on to the main solenoid coil, and when the switchboard controller is turned back to the normal position, the resulting de-energizing of the contactor coil will enable the contactor to open and break the main circuit. It will be understood that the breaking of this circuit is more onerous than the making of it, since the solenoid, with its high density magnetic circuit, provides an inductance of considerable value.

The current-carrying capacity of this contactor need not be of the same value as that of the normal closing current of the solenoid, since the rating of the contactor will be for continuous service, whilst the duration of the solenoid operation will be quite short. The breaking capacity of the contactor must, however, be carefully considered, because, not only are operating currents large, but also the highly inductive nature of the circuit creates a peak e.m.f. at the instant of break. In the interests of cable economy, this contactor is generally mounted in the solenoid mechanism box, and the cables are brought to it through sealing glands attached to the box.

The difficulty in extinguishing the current of these solenoids can be reduced by connecting a non-inductive resistance across the solenoid terminals. Thus the induced energy can be partly absorbed through this resistance. To connect the resistance in parallel with the coil will result in an increase in current, and since it is presumed that this is already large, under some circumstances such an increase may be prohibitive. In this case, the alternative is to arrange the resistance to come into action when the contactor opens.

As regards the trip coil and mechanism, there are at least four points to be taken into consideration.

(1) The iron circuit of the trip coil should be independent of that of the closing-coil circuit. This will prevent interference between these two fields when both coils are being energized at the same time, which is the condition created when the free-handle device is called into action. Fig. 145 shows an incorrect arrangement.

(2) It is desirable that the trip mechanism shall be capable of functioning throughout the full stroke of the closing operation, which implies that at any position in the travel of the mechanism during closing the energizing of the trip coil will

trip the breaker. This will prevent the breaker from being held in on fault condition by the hand closing lever. Fig. 145 illustrates a wrong arrangement.

(3) The sensitivity of the trip mechanism may be affected by the pull of the closing solenoid. Thus, at the instant when the breaker has just closed and the solenoid is still energized, the pull of the latter on the mechanism may result in a force greater than normal to hold the trip mechanism rigid. The trip coil must be sufficiently strong to meet this condition. See Fig. 145.

(4) There are two schools of thought in regard to trip mechanism sensitivity—

(a) A light trip involving a number of toggles.

(b) A heavier but more simple mechanism.

With the first arrangement the power required to operate the mechanism is small, and the setting of the mechanism is not a critical matter. The second arrangement makes use of the fact that as, due to closing coil requirements, the power available is ample, the number of levers and toggles can be reduced to a minimum.

There are many designs of solenoid mechanism, but two only will be described and illustrated.

THE METROPOLITAN-VICKERS SOLENOID MECHANISM. A general view of this mechanism when in the open position is shown in Fig. 147. The solenoid is coupled in direct line with a vertical operating rod by means of a simple free-handle tripping mechanism.

The operating features can best be understood with the aid of the diagrams in Figs. 148 and 149. These illustrations differ from the actual mechanism in that one half only is shown. The resetting springs and trip lever are also diagrammatic, as their inclusion in a correct position would complicate the diagram. The mechanism proper has duplicate toggle links and hold-in catches situated on either side of the operating rod; these are shown clearly in Fig. 147.

The coupling between the fixed and free portions is made by a single toggle, one member of which is in tension and one in compression. The tension lever *A* is attached to a carriage *B*, which in turn is fixed to the solenoid *C*. The end of *A* is so shaped that it can only swing in a counter-clockwise direction. The compression lever *D*, which carries a ballrace *E* at its lower end, is also made to travel during tripping in a counter-clockwise direction about its pivoted centre *F*. Movement in the

250 *OUTDOOR HIGH VOLTAGE SWITCHGEAR*

opposite direction is prevented by the stop *G*, which forms a part of lever *A*. An adjusting screw *H*, which is fitted in lever *D*, enables the angular set of the toggle to be varied. Lever *D* must be so adjusted that the centre of the ballrace is to the left of the centre-line of lever *A*. Both levers *A* and *D* are

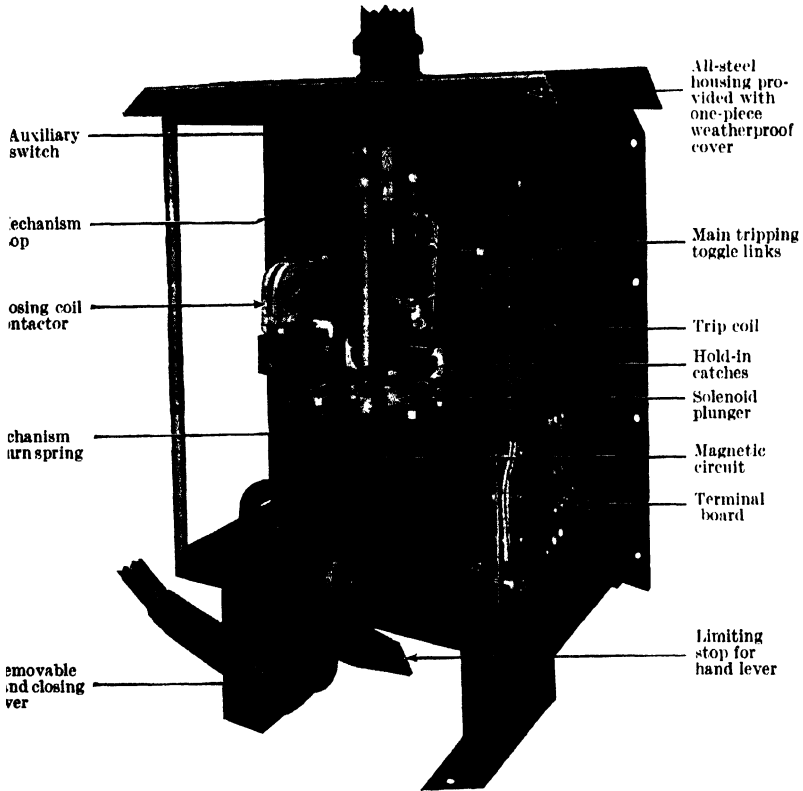

FIG. 147. SOLENOID-OPERATED TYPE "T" CLOSING MECHANISM

(Metropolitan-Vickers Elec. Co., Ltd.)

retained in their correct position by tension spring *J*. The ballrace *E* rests on the horizontal face of the operating rod extension *K*, to which is attached the hold-in catch *L*. This catch is so shaped at its pivoted end that it cannot swing upwards. When the mechanism is in its normal position, viz. the trip coil not energized, the projection *M* on the carriage *B*

prevents the catch *L* from moving downwards. In this condition the free and fixed portions can be moved as a unit, the solenoid and operating rod being solidly coupled. Assuming that the breaker is in the open position, the energizing of the solenoid will pull the complete assembly downwards until the

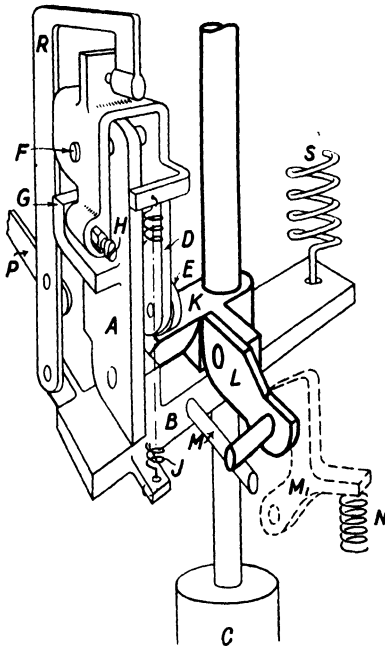

FIG. 148

DIAGRAM OF METROPOLITAN-VICKERS SOLENOID-CLOSING MECHANISM SHOWN IN A CLOSED POSITION

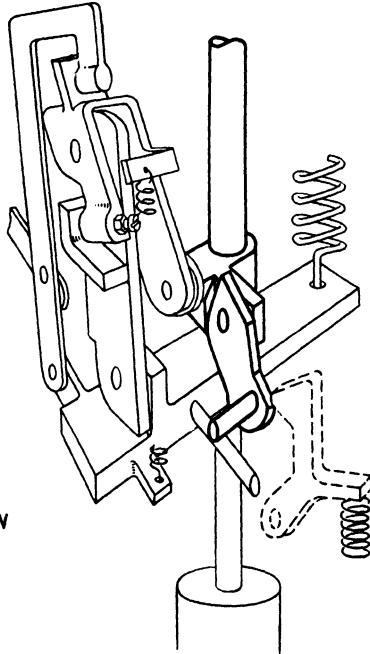

FIG. 149

DIAGRAM SHOWING THE MECHANISM IMMEDIATELY AFTER TRIPPING

catch *L* strikes the trigger *M*, which is attached to the top of the solenoid iron circuit. As catch *L* is firmly held, trigger *M* is forced back against its spring *N* until *L* has passed, at which point trigger *M*₁ is returned by its spring *N*. As the pivot centre of *M*₁ is directly below the middle of the catch face of *L*, the mechanism assembly is held in the "on" position.

Tripping takes place in the following manner—

The trip coil, which is not shown in the diagram, causes the trip rod *P* to be pulled horizontally, thus turning the trip lever

R on its centre, which in turn rotates the toggle assembly. The position of the toggle levers is now as shown in Fig. 149. It will be noted that lever *D* at this stage is at such an angle that the pull of the breaker will cause it to move to the right, until the ballrace *E* slides off the operating rod extension *K*. The pull rod or fixed portion is now free, and the hold on catch *L* releases itself by rotating in a clockwise direction. Thus the breaker moves to the completely open position. Fig. 149 shows the mechanism at the point when the catch *L* is just releasing. The solenoid and toggle mechanism, usually known as the *free* portion, is now detached from the breaker and can be raised to the re-engaging position by means of a resetting spring *S*. On the upward stroke the ballrace strikes and slides up the sloping face on the underside of the rod extension *K*, snapping into the reset position by virtue of the spring *J*. It should be noted that the trip lever *R* is carried on the carriage *B*, and is therefore in a position to trip the mechanism at any point of the closing stroke. Furthermore, when the trip lever *R* is in the tripped position it is impossible to close the breaker, as the ballrace *E* will slip off its platform on *K* when the solenoid is energized, and the carriage and its levers only will be pulled to the "on" position. Thus the mechanism is "free-handle" throughout the whole of its stroke and cannot pump. There is no dashpot or buffer springs to absorb the closing shock: the stop for the closed position is formed by the solenoid plunger hitting against its pole piece. A fullerboard washer is placed on top of the pole-piece to prevent a metal-to-metal impact. To enable the mechanism to be closed by hand, a pull-rod is passed through a hole in the pole-piece and screwed into the solenoid plunger. To the opposite end of the rod is attached a section of roller chain, which in turn is fixed to one end of a cam. The cam is keyed to a shaft which is hexagonal at one end, this end protruding in front of the mechanism containing box. By means of the closing handle, which may be likened to a large spanner, the shaft can be revolved, giving a straight-line pull on the solenoid by virtue of the chain and cam arrangement. (Fig. 150.)

FERGUSON PAILIN TYPE "C" SOLENOID-OPERATING MECHANISM. The special feature of this mechanism is shown in Fig. 151 (*a*), (*b*) and (*c*). It comprises a chain coupling between the solenoid plunger shaft *A* and the circuit-breaker connecting rod *B*. The coupling chain *C* is enclosed in a steel

race, the top portion D of which is a loose member pivoted at E . The member D is normally held in the closed position by the lever latch F , pivoted at G .

To close the circuit-breaker, the solenoid exerts a force along A that pushes the rod B through the medium of the chain C .

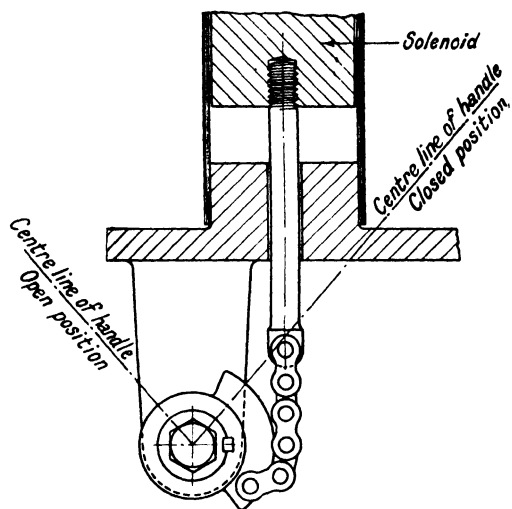

FIG. 150. A CHAIN AND CAM ARRANGEMENT USED FOR HAND OPERATING SOLENOID-TYPE MECHANISMS

The chain C is prevented from collapsing under the compression by the constraining action of the portion of the race D . At the end of the closing stroke, the spring-loaded catch H engages with the shaft A to hold it locked.

To trip the breaker, the trip-coil mechanism operates on the lever latch F to release it from D . As the shaft A is held by the catch H , the chain C is able to collapse under the pressure from B into the position shown in Fig. 151 (b), because the restraint is now withdrawn from D , which latter rotates about its centre E into the position shown. It is clear from the figure that the trip feature can operate with the mechanism in any part of its closing stroke. When the breaker reaches the open position, the catch H is released and the shaft A drops and the mechanism resets itself. This mechanism has the advantage of simplicity, since there are no levers or links involved. Fig. 152 shows the mechanism in its weatherproof housing.

Motor-operated Mechanism. The advantage of a motor-operated mechanism is twofold. In the first place it may be used on either an a.c. or d.c. supply, and secondly it absorbs less power for the purpose in hand. The first essential of design

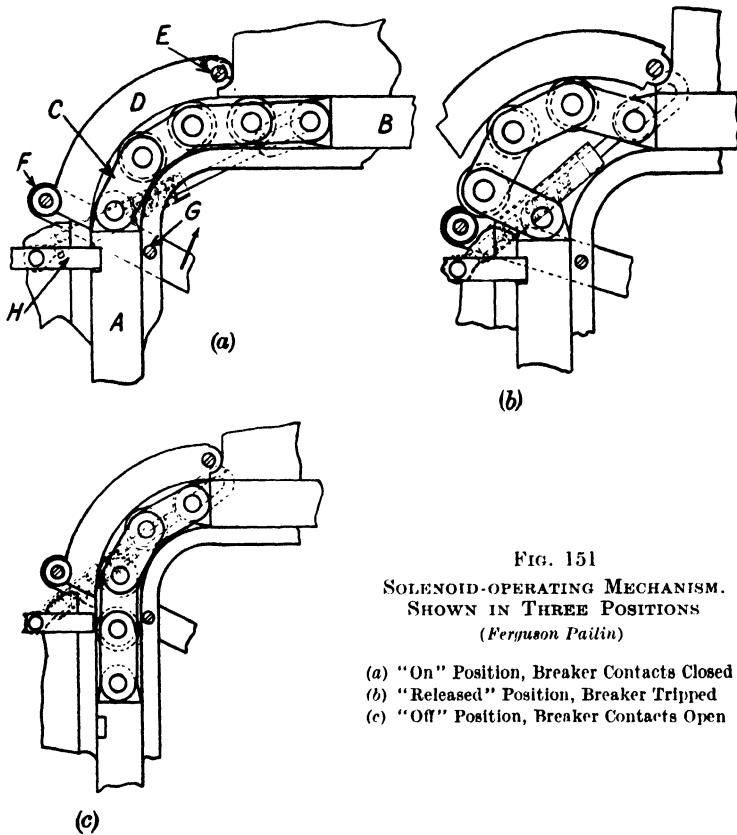

FIG. 151
SOLENOID-OPERATING MECHANISM.
SHOWN IN THREE POSITIONS
(*Ferguson Pailin*)

- (a) "On" Position, Breaker Contacts Closed
- (b) "Released" Position, Breaker Tripped
- (c) "Off" Position, Breaker Contacts Open

in this type of mechanism is the transformation of the rotary motion of the high-speed motor into a straight line pull on the operating shaft. This involves more parts than are needed in the solenoid mechanism. The free-handle feature must also be embodied in the motor-type mechanism as in the other types.

Various methods of operation have been devised for such mechanisms, and some of these are described below.

FLYWHEEL TYPE. In this, a flywheel of suitable proportions is driven up to speed by the motor, and, when sufficient kinetic energy has been stored, a clutch operates to disconnect the flywheel from the motor and connect it to the mechanism of the pull-rod. The clutch may be controlled by a small solenoid or by centrifugal force.

SPRING TYPE. In this case, the motor operates through a geared mechanism to extend a spring. The potential energy of the extended spring provides the force required on the pull-rod to close the breaker. A tripping mechanism is used to release the spring for this purpose.

A point in regard to this type of mechanism is that the springs are almost continuously energized, awaiting the need for operation.

The main drawback to these two types is that the energy of the motor has to be passed into some form of intermediary before it reaches the pull-rod of the circuit-breaker contact mechanism. This entails loss of time, and generally renders the oil circuit-breaker unsuitable for the purposes of synchronizing. Thus there is the time required for the flywheel to reach the requisite speed, and then the time for the clutch to operate to disconnect it from one mechanism and connect it to the other. The spring-type mechanism has the disadvantage that for operations in succession, time must be allowed for the spring to be reset between each operation.

CENTRIFUGAL MOTOR TYPE. Here the motor is made to drive a mechanism in the form of governor balls. One end of this mechanism is attached to the motor spindle and the other to the free-handle breaker mechanism. Thus, when the motor speeds up, the balls fly outwards, and as a result, the end of the mechanism attached to the breaker pull-rod is

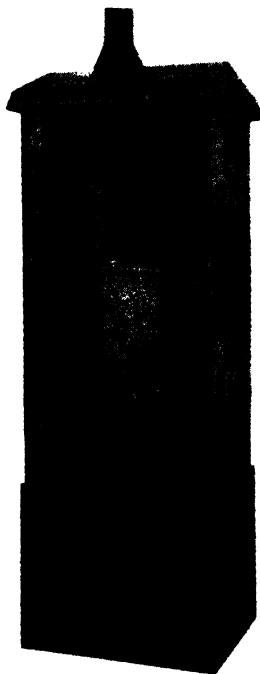

FIG. 152
SOLENOID OPERATING
MECHANISM
(*Ferguson Patent*)

drawn downwards. The action, therefore, is direct. This is undoubtedly the most popular type, mainly perhaps because the time interval between the closing of the control switch and the breaker reaching the fully closed position is practically the same as that for a solenoid mechanism.

The cost of the motor and governor mechanism is generally more than that for a solenoid. To some extent this is accounted for by the finer accuracies that are necessary in the mechanical parts. The motor speed may require to be of the order of 5 000 r.p.m., dependent upon the power to be developed. For this reason the governor portion is mounted on ball races and the revolving parts are properly balanced. A limit-switch operated by the mechanism cuts off the motor from the supply source a fraction of a second before the circuit-breaker is fully closed, and the stored energy is sufficient to latch the mechanism in the closed position.

BRITISH THOMSON-HOUSTON FORM B2 MECHANISM. Fig. 153 shows a part section of this mechanism, and Fig. 154 (*a*) shows diagrammatically the mechanism in the normal position, that is, with the breaker open and the mechanism reset ready for closing. In this position the fly-weights *A* are near the vertical motor shaft *B*, to which they are connected by links *C*, and to a crossbar *D* by links *E*.

Links *F* connect the crossbar *D* to a crank *G* that rotates about its fulcrum and operates a tension toggle linkage formed by links *H*, *J* and *K* through the medium of link *L*. The movement of the free end of the toggle linkage, link *H*, is restrained by a link *M* that is fixed to a fulcrum *N*.

A main bell crank *O*, which rotates about its fulcrum and operates the breaker connecting-rod *P*, is connected to one end of the toggle linkage; the other end of the latter is secured by link *Q* to a fulcrum *R* and also to a tripping mechanism through link *S*. The tripping mechanism consists of a number of toggles "in series" with a roller *T* on the end link to engage with the actual tripping latch *U*.

As the motor gathers speed—reaching maximum speed almost instantaneously—the fly-weights are forced outwards, and the links *C* and *E* take up the position indicated in Fig. 154 (*b*). The crossbar *D* is thus pulled downwards, drawing with it the longer arm of the operating crank *G*. The shorter arm moves upwards, and link *L* draws the toggle links *H*, *J* and *K* towards the left. This rotates the main bell crank *O* about its fulcrum

and, therefore, the breaker connecting-rod P is drawn downwards. The shorter arm of the operating crank G continues to move upwards until the link L has passed the centre of the fulcrum of crank G , and then it is locked in this position by

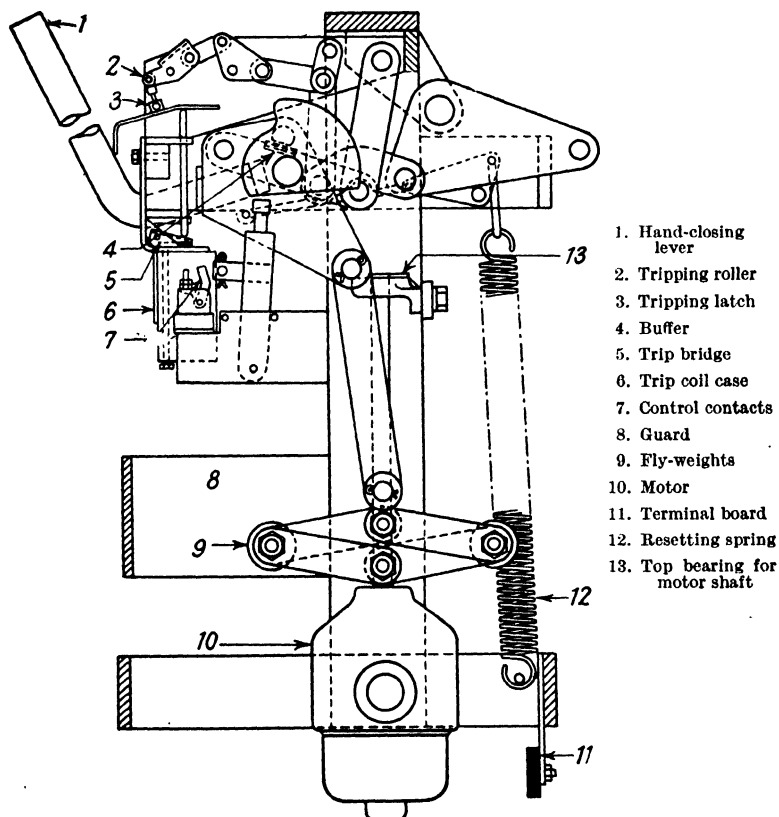
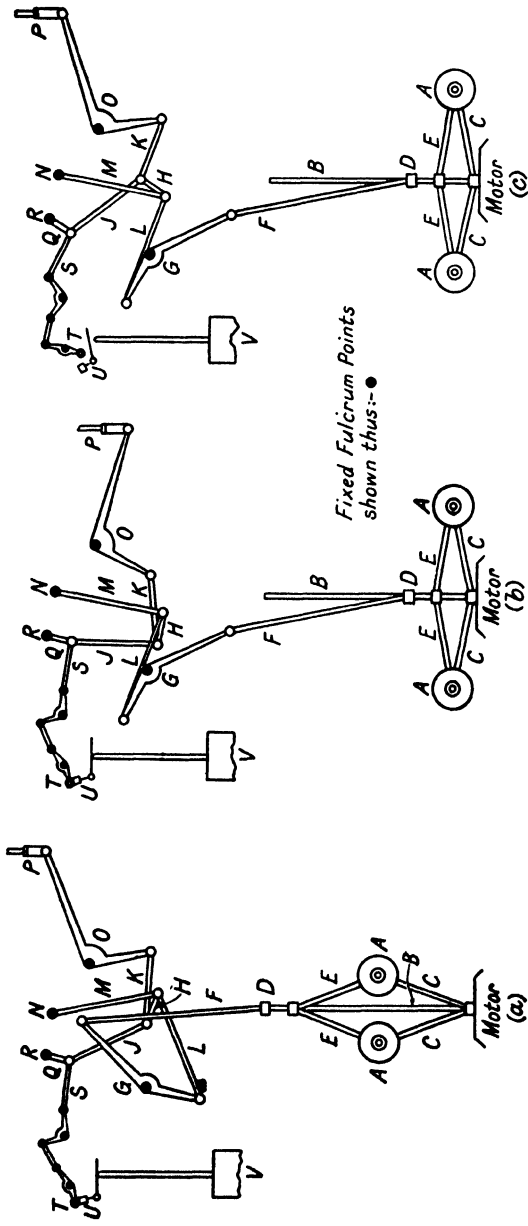

FIG. 153. MOTOR OPERATED CLOSING MECHANISM
(British Thomson-Houston Co., Ltd.)

the upward pull exerted by the weight of the breaker moving parts and the pressure of the accelerating springs. The mechanism is now in the position shown in Fig. 154 (b), that is, the breaker is closed and the mechanism is still reset.

When the mechanism is tripped—either by hand or due to the action of one of the automatic features V —the tripping



Breaker open, mechanism reset.

Breaker closed.

Breaker tripped, mechanism not reset.

FIG. 154. DIAGRAM OF OPERATION FOR THE MECHANISM SHOWN IN FIGS. 153 AND 155

latch U is moved clear of the roller T , which falls down behind it. The toggles of the tripping linkage then collapse as shown in Fig. 154 (c). This removes the forces restraining the toggle links J , H and K , so that the links H and K —which have

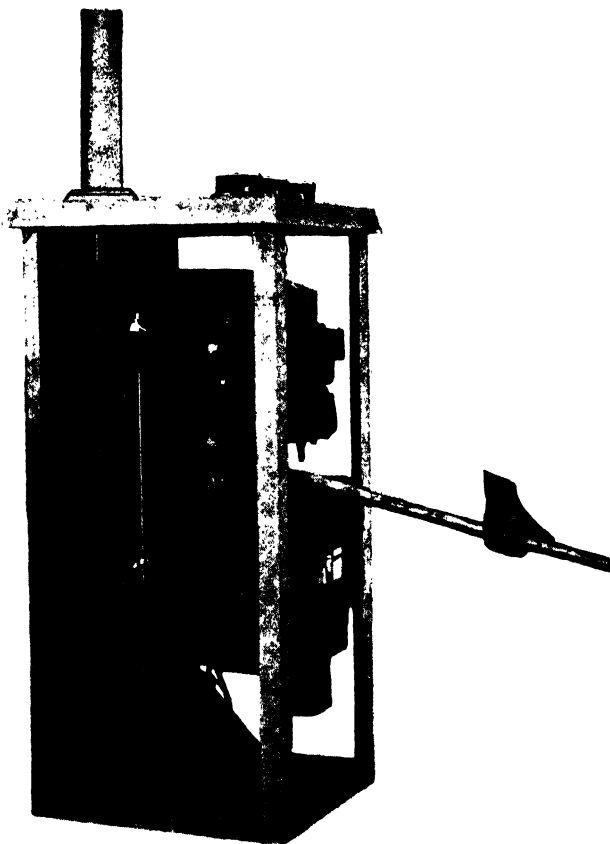

FIG. 155. MOTOR OPERATING MECHANISM
(British Thomson-Houston Co.)

hitherto maintained an acute angle between them—open out and allow the main bell crank O to return to its original position under the weight of the breaker parts and the breaker accelerating springs.

The resetting spring 12, Fig. 153, aided by the weight of the mechanism parts, then draws the fly-weights upwards to

their original position, at the same time resetting the latching mechanism. The links and levers are now again in the normal position, as shown in Fig. 154 (a).

A buffer 4, Fig. 153, consisting of a number of steel plates, is provided to cushion the impact of the centrifugal mechanism when it reaches the fully-closed position.

Compressed Air-operating Mechanism. This method of closing oil circuit-breakers is really an old one. It fell into disfavour, however, as a result of its general unreliability. Some of these causes of failure may be summarized as follows—

(1) Leakage of air caused by poor joints and incorrectly designed valves.

(2) Sticking, due to dirt and condensation.

(3) Inefficient compression gear, which failed to come into action when the pressure in the storage cylinder dropped to the danger value.

There were also cases where the three phases of the circuit-breaker were not mechanically interconnected, but each phase had its own air-operating piston. With this arrangement it was possible to have one or two phases of the breaker operating whilst another would remain dormant. As a result, maintenance work was found to be excessive and expensive, especially as it often involved the breaking and making of airtight pressure joints, as well as extreme care in cleaning.

The recent development of circuit-breakers of the air-blast and compression types has brought with it an improvement generally in compressed air application. One of the main difficulties is to ensure that the pressure shall be maintained during long periods of inactivity. This means that even the smallest leaks become important, because a small leak acting over a long period is just as damaging to efficiency as a large leak over a short time. If air leaks could be entirely removed, then quite a small capacity air reservoir would suffice for circuit-breaker operation because of the infrequent use and the comparatively small amount of air used at each operation.

The advantages obtained with an efficient air system may be stated thus—

(1) An independent source of power is available. This is equivalent to the electric battery power supply, which is also independent. But, compared with the battery, the air supply has these advantages—

(a) It requires no special room to house the equipment, as does the battery because of the acid fumes.

(b) The equipment is easy to accommodate and comparatively light in weight.

(2) High-speed operation can be attained, and this without the same shock to the mechanism as with springs.

Up to the present, however, the application of the compressed air mechanism is found mostly on the continent of Europe in connection with expansion and air-blast circuit-breakers. It is being used to some small extent in the U.S.A., and to an even smaller extent in Great Britain.

Although this mechanism has been put into use for closing circuit-breakers, its application to the purpose of tripping has yet to be accomplished. One of the difficulties of the latter use will be to adapt the air-tripping device to the operation of the protective relays. Indeed, the relay itself would have to be of a special type in order to meet these requirements, and quite a system of small air pipes would be needed from the relays to the circuit-breaker trip gear. Alternatively, of course, the present standard auxiliary tripping supply may be used for operation between the relay and the circuit-breaker trip mechanism, but then this involves another supply source of energy in addition to the air supply.

To produce valves, joints, pistons, etc., of the accuracy that will ensure airtightness would entail considerable expense in manufacture, so that on the whole it would seem that the adoption of such a mechanism must result in a more costly oil circuit-breaker.

BIBLIOGRAPHY

- A.I.E.E. Stds. No. 19.
- B.S.S. No. 116.
- B.S.S. No. 148.
- B. P. Baker and H. M. Wilcox, A.I.E.E. Winter Conference, 1930.
- W. A. Coates, Discussion on Pearce and Evan's paper, *J.I.E.E.*, 1932.
- L. W. Dyer, *Elec. World*, April, 1930.
- B. L. Goodlet, F. S. Edwards and F. R. Perry, *J.I.E.E.*, Vol. 69, 1931.
- J. D. Hilliary, *J.A.I.E.E.*, 1924.
- Miner, *J.A.I.E.E.*, April, 1927.
- D. C. Prince and E. J. Poitras, *Elec. World*, Feb., 1931.
- R. M. Spurk and H. E. Strang, A.I.E.E. Winter Conference, 1931.
- J. Slepian, A.I.E.E. Winter Conference, 1930.
- S. Whitehead, *Dielectric Phenomena*. (McGraw Hall.)

262 OUTDOOR HIGH VOLTAGE SWITCHGEAR

"Oil Circuit-breaker Tests, Philadelphia, 1930," Philip Sporn and Harry P. St. Clair, A.I.E.E. Winter Conference, 1931.

"The Oil-blast Circuit-breaker," D.C. Prince and W. F. Skeats, A.I.E.E. Winter Conference, 1931.

"The Theory of Oil-blast Breakers," D. C. Prince, *A.I.E.E.*, March, 1932.

"Engineering Features of Oil-blast Action," D. C. Prince, *General Electric Review*, August, 1933.

CHAPTER X

BUSHING INSULATORS

IN Chapter IV the general principles of electrostatics were introduced. It will be necessary to proceed a little further into these to enunciate more closely the problem of the bushing insulator. This problem is precisely that of bringing an electrified conductor through an earthed ring or cylinder. The charge carried by such a conductor is associated with a field of lines of force, or tubes of force; the latter having the property that their density over a given area is proportional to the intensity across that area. Thus the intensity varies inversely as the cross-section of the tube. It is a convention that every tube has its origin on a unit positive charge and ends on a unit negative one. From this it may be deduced that the total charge on a conductor is numerically equal to the excess of the number of tubes that leave a conductor over the number that arrive on it. This excess is called the *polarization*, and is equivalent to Maxwell's dielectric displacement current. The tubes exist in a state of axial tension and lateral repulsion. The former constitutes the stress in the dielectric, and the safe accommodation of such stress is the problem of the bushing insulator.

The tension along the tubes of force is a constant for each tube, which results in the direct proportion between field intensity and number of tubes per unit area. Such a system will represent energy, and the energy of a unit length of tube can be proved to be equal numerically to the tension that exists along that unit length, or, again, to half the intensity of that unit length. Thus, if Q equals the charge, and $V_1 - V_2$ the potential difference, the energy will be equal to

$$\frac{1}{2}Q (V_1 - V_2) \text{ per unit length} \quad . \quad . \quad . \quad . \quad . \quad . \quad (72)$$

When Q is unity, as it is for each separate tube, then the energy is equal to

$$\frac{1}{2} (V_1 - V_2) \text{ per unit length} \quad . \quad . \quad . \quad . \quad . \quad . \quad (73)$$

that is, to half the intensity.

The additional factors are due to unit constants, and τ is the velocity of light which is equal to 3×10^{10} cm. per sec.

If, now, a conductor at high potential is passed through an earthed cylinder, the distribution of flux will be something like that shown in Fig. 156. From this figure it will be observed that there is a much higher flux density at the ends of the earth band than on the surface of the conductor. Also, within the body of the earth band, the flux density is less on the band

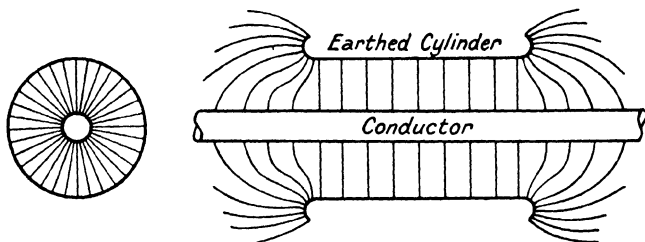

FIG. 156. SHOWING DISTRIBUTION OF FLUX BETWEEN AN ELECTRIFIED CONDUCTOR AND A CONCENTRIC EARTHED CYLINDER

than it is on the conductor surface. Altogether, the flux distribution is very unequal.

The earth band, and that portion of the conductor which passes through it, form the equivalent of two co-axial cylinders. The capacitance between them is therefore

$$\frac{1}{2 \log_e (r_b/r_c)} \dots \dots \dots (76)$$

where r_b is the radius of the earth band, and r_c the radius of the conductor. Consequently if Q is the charge on the conductor per unit length, the potential distribution between conductor and cylinder will be

$$P = 2Q \log_e (r_b/r_c) \dots \dots \dots (77)$$

This is the equation to the curve in Fig. 157, from which it will be seen that the potential gradient is much steeper near the conductor than farther away. In the higher voltage range, this inequality in the potential stress becomes serious, and in all well-designed bushing insulators an endeavour is made to control the field or adjust the dielectric to make this stress more uniform.

In Chapter IV it has been shown to what extent the field form is affected by the introduction of various dielectrics and conductors. Therefore it will be understood that if metallic or insulation cylinders be inserted in the dielectric medium between the conductor and earth band, the field form may be affected to a greater or lesser extent, according to the nature, size and relative disposition of the cylinders in question. And

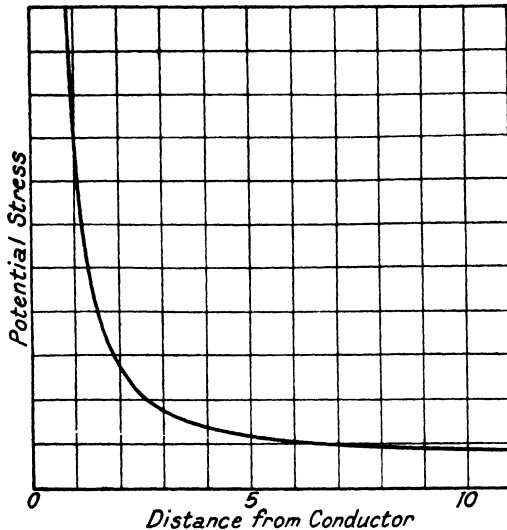

FIG. 157. SHOWING DISTRIBUTION OF POTENTIAL OR POTENTIAL GRADIENT BETWEEN ELECTRIFIED CONDUCTOR AND CONCENTRIC CYLINDER

$$\text{Equation to curve is: } P = 2Q \log_{\epsilon} \frac{r_b}{r_c}$$

this is true irrespective of whether the dielectric medium is oil, paper, porcelain or compound, etc. It would therefore seem necessary only to choose a suitable material for these cylinders, and so to dimension and dispose it as to obtain whatever field control was required. In general this is true, although in particular it is not quite so simple.

Several types of bushings have been designed embodying the above principle to a smaller or greater extent. There is the *Hermisdorf bushing* made of built-up porcelain, shown in Fig. 158. This cannot be graded to the same extent as can the so-called *condenser bushing* shown in Fig. 159. The latter is

constructed by winding layers of treated paper on the conductor rod, and by inserting layers of tin-foil between the paper at calculated spacings. In the Hermsdorf bushing the thickness of the porcelain is the limiting feature, whilst in the condenser type it is the thickness of the paper layers.

The value of a bushing depends not only on its ability to control the dielectric stress, but also upon the quality and strength of the actual dielectric used.

At a particular potential a given conductor will carry a definite charge per unit area, which charge will represent a certain field flux density at the surface. For that portion of the conductor which lies within the cylindrical earth band, the field will radiate in straight lines perpendicular to the conductor and inner cylinder surface. All equipotential surfaces between the limits of conductor and earth band will be cylinders and will be concentric with the conductor and earth band. As explained in Chapter IV, the insertion into a field of bodies of metal or insulation, shaped to conform to equipotential surfaces, will cause no disturbance or distortion of that field. The introduction of such cylindrical bodies will, however, convert the space between conductor and earth band into a number of condensers in series.

The displacement current that passes through each of these condensers will be the same, because, except for a certain loss at the edges, the whole of the flux that leaves the surface of the conductor over the bushing length will end on the inner surface of the earth band. In doing so it will necessarily pass through each of the condensers *en route*. In this case, then, the value of Q is

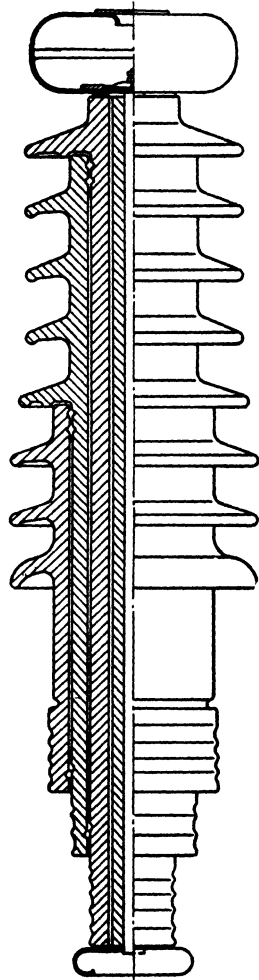

FIG. 158. HERMSDORF BUSHING MADE OF BUILT-UP PORCELAINS

constant. Therefore, because $Q = CV$, it only remains to make the capacitance of each of the condenser steps the same, to effect constant voltage per step.

The Condenser Type Bushing. To consider the condenser bushing, Fig. 159, let ϵ be the field intensity; then the displacement will be $\epsilon\kappa/4\pi$, which is equal to the surface density; κ being the dielectric constant. Again, if Q is the total charge on a metal layer of radius r and length l , then $Q = \kappa CV$. From this the surface density will be $\kappa CV/2\pi rl$, and the theory of constant displacement for all layers is thus mathematically expressed by

$$\epsilon\kappa/4\pi = \kappa CV/2\pi rl \text{ or } 2CV = \epsilon rl,$$

whence, because $2CV$ is constant for each layer

$$\epsilon = \text{constant}/rl \quad \dots \dots \dots (78)$$

The equation (78), however, gives the condition for a hyperbola. This means that the ends of the metal layers will form a curve of that order, with the conductor as one of the asymptotes. These proportions would give practically constant radial stress, which is the purpose of the Nagel design. But this would result in a condition of unequal axial stress, because of unequal differences in the lengths of these layers.

The Fortescue design aims at constant axial stress and accommodates unequal radial stress. In this design the lengths of the metal cylinders are arranged in arithmetical progression, and r is proportioned to maintain equal capacitance per step. It therefore follows that the voltage per step will be equal, and because these equal voltages are impressed across equal length differences between successive steps, the axial stress will be constant.

From the equation for the geometric capacitance of coaxial cylinders, the formula for steps of equal capacitance may be deduced to be

$$C = \frac{l_x \kappa}{2 \log_e (r_{ox}/r_{ix})} \quad \dots \dots \dots (79)$$

where C is the capacitance of each step, l_x the length of any step x , r_{ox} the radius of the outer metal layer of step x , and r_{ix} the radius of the inner metal layer of step x . Because of the difference in layer lengths and the admittance to ground of each layer, the above formula is not strictly correct, but the error is small enough to be of no consequence in practice.

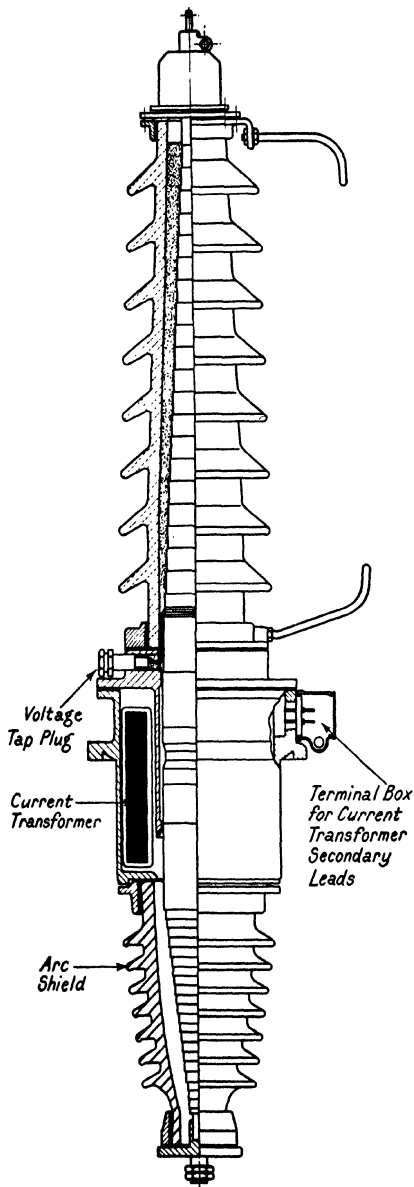

FIG. 150

CONDENSER TYPE BUSHING INSULATOR
Showing bushing type current transformer.

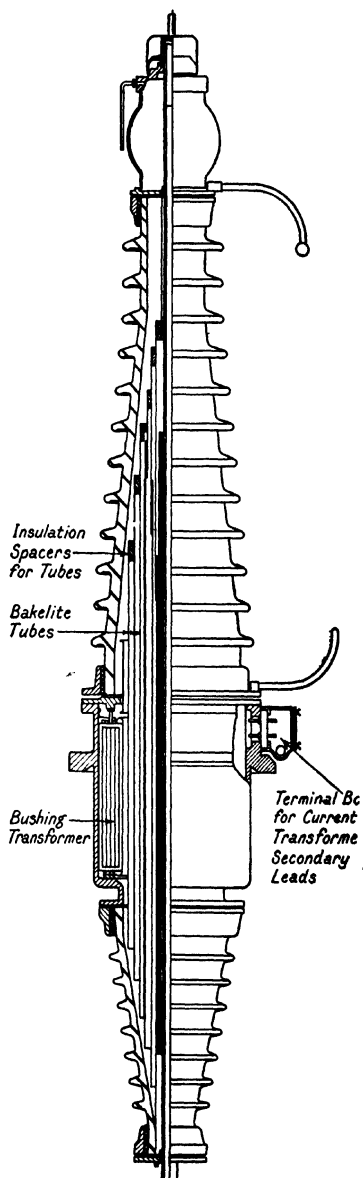

FIG. 160

OIL-FILLED TYPE BUSHING INSULATOR
Showing bushing type current transformer.

From the conditions of the case, l forms a series in arithmetical progression; therefore the corresponding values of $2 \log_e (r_o/r_i)$ in equation (79) will necessarily form a similar series in order to keep the value of the capacitance equation constant. It will be found that if the logarithms of the ratios of the radii of the metal layers are to form an arithmetical progression, the difference between the radii of successive metal layers will not be constant; that is, the thickness of the dielectric layers will not be constant. It can be proved that these dielectric layer thicknesses form another series which can be expressed by an equation to a parabola: or, if the number of the layer is plotted against the thickness of the layer, the resulting curve is a parabola. When calculating for the design of these bushings, it is as well to plot this curve, since any mistake in the calculation will immediately show up as an irregularity in the curve, and if the thicknesses of the first and last steps are unequal, an uneconomic design is indicated.

The Oil-Filled Bushing. When metal cylinders are not used to obtain stress grading but rather insulation cylinders, the control is governed by the nature and disposition of the dielectric used. An example of such a bushing—a so-called *oil-filled bushing*—is shown in Fig. 160. In this the central conductor passes through an oil-filled chamber comprising an upper and a lower porcelain casing connected to either end of a cylindrical earth flange. Solid dielectric tubes of various lengths and diameters are inserted in the oil chamber concentric with the conductor.

In the bushing illustrated these tubes are of bakelite, but in certain makes they may be of dry paper or porcelain, and fewer in number. On the other hand, for bushings up to 66 kV. rating, the oil and insulation tubes are sometimes omitted, and the space filled up with compound. It will, of course, be realized that the less the advantage that is taken of the gradient possibilities, the bigger will the diameter of a bushing become.

The equation controlling the design of dielectrics in series is that given below

$$G_x = \frac{1}{x\kappa_x} \cdot \frac{E}{\frac{\log_e (r_2/r_1)}{\kappa_1} + \frac{\log_e (r_3/r_2)}{\kappa_2} + \dots + \frac{\log_e (r_{x+1}/r_x)}{\kappa_x}}{\frac{E}{\dots + \frac{\log_e (r_{n+1}/r_n)}{\kappa_n}}} \quad (80)$$

where G_x is the potential gradient at a point x , E the applied voltage, and κ the dielectric constant.

The two best-known types of high voltage bushings in general use are the oil-filled and condenser types. Each has proved itself in service over a long period of years. There are advantages and disadvantages peculiar to the two types, and these are summarized at the end of this chapter.

Both the oil-filled and condenser type bushings have a definite ratio between earth band and conductor diameters that will give the minimum voltage gradient on the surface of the conductor. This is when the ratio of earth band diameter to conductor diameter is equal to e , the base of Napierian logarithms. It can easily be proved thus—

Let r equal the conductor radius, and R equal the earth band radius; then G , the voltage gradient, will equal

$$\frac{dE}{dr} = \frac{E}{r \log_e (R/r)} \quad (81)$$

This will be a minimum when $r \log_e (R/r)$ is a maximum, or when

$$\frac{d [r \log_e (R/r)]}{dr} = 0$$

which occurs when $(R/r) = e$. From this it follows that the most economical proportion between the length of the earth band and the total bushing length is when the ratio of the bushing length to earth band length is also e ; this is deduced as follows. The superficial area of interior surfaces of the earth band should be equal to the superficial area of the conductor under the first insulation layer. Or, $l\pi D/L\pi d$ should equal unity, because these are the plates of the condenser. L equals the length of the conductor under the first insulation layer, d equals the diameter of the conductor, l equals the length of the earth band, and D equals the inside diameter of the earth band. The above reduces to $lD/Ld = 1$. The best ratio of D/d has been shown equal to e ; therefore the ratio for l/L to correspond with these conditions is $1/e$, or the ratio of the bushing length to the earth band length is $L/l = e$.

The two edges of the earth band are subject to a high concentration of lines of force and the adjacent dielectric becomes correspondingly highly stressed. It is therefore advisable to arrange that these edges are immersed in either oil or compound. To overcome this trouble, the earth band is sometimes

buried in the insulation and a false and shorter earth band wound on the outside.

When there is any arrangement by which a complete iron

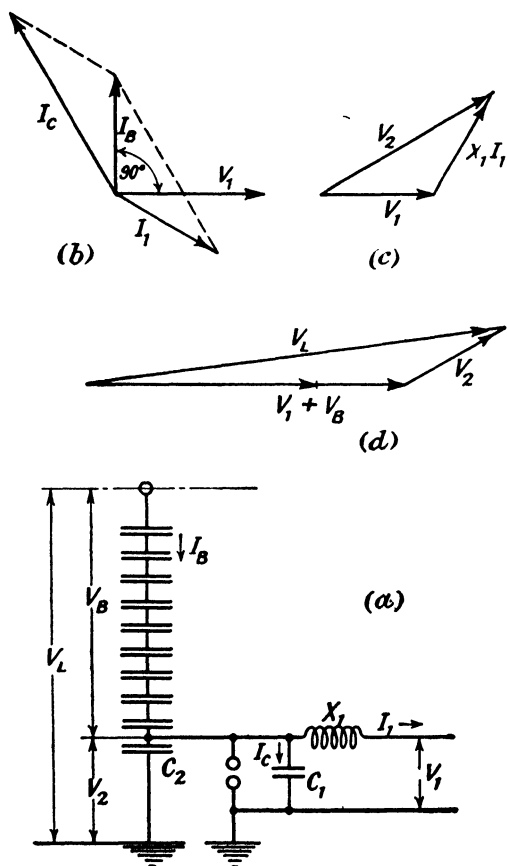

FIG. 161

- (a) Schematic diagram.
- (b) Vector diagram for I_1 , V_1 , I_B , and I_C .
- (c) " " " V_1 , V_2 and $X_1 I_1$.
- (d) " " " V_L , V_2 .

circuit is likely to be formed by a steel wire earth band, this band is made in two sections with about $\frac{1}{10}$ in. between them.

Voltage Tap. A feature that can be incorporated in either type of bushing is the potential tap that can be taken from the

bushing so that the available energy may be used for various purposes. In the condenser type there is a pressure of about 4 000 volts per step on the bushing, and a connection is sometimes made from the last metal layer before the earth band. This connection is brought out to a suitable terminal or plug socket. There is thus available a potential of approximately 4 000 volts between this tap connection and earth band, which pressure may be stepped down through a voltage transformer to a working pressure of, say, 110 volts. This source of supply can be used for synchronizing equipment. It is necessary to include in the 110 volt secondary circuit of the transformer a tuning device comprising variable reactor and condenser. By this means adjustment can be made for voltage regulation and

TABLE XIV

Line Voltage	Output at 110 V.
88 kV.	10 VA.
110 "	12 "
132 "	15 "
154 "	20 "
220 "	30 "

vector relationship. The output, regulation, etc., will depend upon the nature and extent of the secondary burden as a whole, since a change in burden will cause a corresponding change in pressure across the tapped step of the bushing. This will result in a change in voltage distribution across the other steps and in a change in the charging current of the bushing.

In Fig. 161 schematic and vector diagrams are given to illustrate the above more clearly. It is to be remembered that the voltage V_1 is required to be in lagging quadrature with the charging current I_b , and so reproduce the normal relationship between the bushing voltage and charging current. This charging current I_b will be the vectorial sum of I_1 and I_c , and V_1 is required to be 90° behind I_b . The vector diagram to obtain this condition is shown in (b), Fig. 161. Now V_1 will be the vectorial sum of V_2 and $X_1 I_1$, shown in (c), Fig. 161; and V_L will be the vectorial sum of $(V_1 + V_b)$ and V_2 : which is shown in (d). This gives the conditions required. In addition to the above, the constants of the secondary burden must be

included before a case can be fully considered. In Table XIV is given the likely VA. output to be expected from such tapped bushings. The output from the tapped oil-filled bushing will be slightly lower.

DESIGN DATA

In the foregoing pages the bushing insulator has been considered from the theoretical point of view, since such is necessary to form the basis of design. In addition to this, there is an amount of data required on the physical properties of the materials used before a design can be completed. The actual manufacture of the bushing cannot be treated in a book of this nature, since the methods vary with different makers. To describe these methods would involve more space than is available.

It is an axiom of all bushing design that the air end shall spark-over (*a*) before puncture of the bushing, or (*b*) before spark-over at the oil end occurs. To enable the designer to calculate for this condition, the following data must be in his possession—

(i) The spark-over values across different shapes of porcelain insulators; both in air and in oil, and for dry and wet conditions.

(ii) The spark-over values across the surface of materials such as bakelite, porcelain, etc., both in air and under oil. This is known as the *electric strength of surface*, and for bakelite, when in oil, corresponds to the electric strength along the laminae.

(iii) The puncture value, or *electric strength* of bakelite, porcelain, etc.

Reference should be made to the B.S.I. Specifications Nos. 223 and 316 for *Electrical Performance of High Voltage Bushing Insulators*, and *Synthetic-Resin Varnish-Paper Boards and Tubes* respectively, in which are given standard specifications and tests.

In all types of spark-over tests in air, the state of the atmosphere is of importance. It is therefore customary to make such tests under given atmospheric conditions, referred to as *controlled atmosphere conditions*. Thus, the relative humidity of the atmosphere must be 75 per cent at a temperature of 15°–25° C., and a barometric pressure of 760 mm. The

correction factor for relative air density, is given by

$$\delta = 0.392 b / (273 + t)$$

where b is barometric pressure in mm. and t is temperature in degrees Centigrade.

The data defined in (i), (ii) and (iii) above are given here-under; but it must be appreciated that quite big variations may be experienced with different classes of materials, and the values given are more general than particular. They represent what may be expected from good quality products, and in accordance with the B.S.I. ruling.

(i) For spark-over values across porcelain insulators in air, see Fig. 39. For shed-type insulators, the wet values may be taken as 65–75 per cent of the dry spark-over.

For spark-over values across the surface of porcelain under oil, the minimum is 15 kV. per in.

(ii) *In Air.* The B.S.I. test value for 1 min. across a surface 1 in. long in air is 12 kV. For lengths such as would be used in bushing insulators a figure of 7.5 kV. per in. may be taken as a safe value.

Under Oil. The B.S.I. test value for 1 min. across a surface 1 in. long under oil is 20 kV. For bushing insulator lengths 15 kV. per in. may be taken.

(iii) The puncture or electric strength of bakelite and similar products is regulated by the B.S.I. one minute test values of

250 kV. per mil for thicknesses up to $\frac{1}{8}$ in.

200 kV. „ „ „ „ $\frac{1}{8}$ in. to $\frac{1}{4}$ in.

The puncture values for various thicknesses of porcelain walls are given in the curves in Fig. 40.

TABLE XV
COMPARISON OF OIL-FILLED WITH CONDENSER TYPE BUSHINGS

	Condenser Type	Oil-filled
<i>Manufacture</i>	Satisfactory service depends upon the quality of the insulation material. Also on the care and skill in manufacture	Provided good porcelain is obtained, satisfactory service depends on simple and easily controlled insulating materials. No special skill is required in manufacture, except in the making of leak-proof joints

276 OUTDOOR HIGH VOLTAGE SWITCHGEAR

TABLE XV—*continued*
COMPARISON OF OIL-FILLED WITH CONDENSER TYPE BUSHINGS

	Condenser Type	Oil-filled
<i>Over-voltage</i>	Due to the grading of the voltage in approximately even steps, the design is inherently good for dealing with over-voltages of short duration. Sudden over-voltages on a well-designed bushing will cause spark-over on the outside of the rainshed before puncture inside the bushing	Oil insulation is inherently well able to withstand prolonged over-voltage. Provided there is no moisture in the oil or insulation tubes, a sudden over-voltage will cause spark-over on the outside of the rainshed before puncture inside the bushing
<i>Dimensions</i>	The overall length from the mounting flange to the terminal at the air end is less with the condenser type than with the oil-filled. The difference is small with l.v. bushings, but quite appreciable with h.v. bushings. The length from flange to terminal under oil in circuit-breaker application is about the same for both types. For transformer application of the bushings, this length can be made less on the oil-filled than on the condenser type The diameter of the hole in the top plate for receiving the bushings can be made smaller with the condenser type than with the oil-filled	
<i>Damage from Blows</i>	Damage to the rainshed does not cause immediate trouble	Will not withstand any damage to the porcelain sheds. A hair crack will leak oil and cause breakdown
<i>Damage from Moisture</i>	The risk of absorbing moisture is small	Slight risk of moisture entering through the oil sight glass vent due to breathing under varying temperature conditions
<i>Leakage of Rainshed Filling Medium</i>	No leakage, if the medium is a thick compound	Great care is necessary to secure oil-tight joints, and further care during slinging to avoid "starting" joints through untoward mechanical stresses
<i>Mechanical Strength</i>	Stronger than oil-filled bushing	No side pull on the bushing is permissible due to the risk of "starting" oil joints

TABLE XV—*continued*
COMPARISON OF OIL-FILLED WITH CONDENSE TYPE BUSHINGS

	Condenser Type	Oil-filled
<i>Erection and Re- placement</i>	Great care is essential when lowering bushings into position in the oil circuit-breaker or transformer that the lower condenser steps are not damaged	There is no exposed insulation to need special care during erection
<i>Maintenance and Checking</i>	Cleaning and inspection of the rainsheds is all that is required	Cleaning and inspection of the rainsheds plus checking of the oil level and condition of the oil
<i>Repairs</i>	Damaged rainshed replacement is a longer and more involved operation than with an oil-filled bushing Damage to insulation cannot be repaired. New bushing would be necessary	Damaged rainshed replacement is a simpler matter than with the condenser type; the only difficulty is to ensure an oiltight joint A damaged insulation tube can be replaced with reasonable ease

TEST METHODS

There are certain standard tests laid down in the B.S.I. Specification No. 223 to which all high voltage bushings are subject. The first of these is the dry and wet pressure test for 1 min. and 30 sec. respectively at 50 cycles per sec. and at n.t.p. The test values specified are given in the specification in tabular form against the rating number of the bushing. The dry test under this heading is a routine test, or one to which each bushing must be submitted.

Type tests are specified as—

- (i) Dry spark-over test.
- (ii) Wet high voltage test.
- (iii) Temperature rise test.
- (iv) Puncture or oil flash-over test.
- (v) Temperature cycle test.
- (vi) Porosity test.

Any tests other than those stated above are covered under the B.S.I. Specification of Performance Tests, and for these

special arrangements are made, dependent upon the nature of the test involved.

There is one test peculiar to the condenser type bushing, which is known as the ‘‘Dielectric loss’’ or ‘‘Watt loss’’ Test. This is a test to determine the quality of the insulation used in the bushing. It is based on the fact that with a perfect insulator the only current is the capacitance charging current; whereas with an imperfect insulator there is in addition a leakage current. The test is made by means of the Schering bridge, and is described in more detail in the next section.

Schering Bridge. An impure condenser can be represented

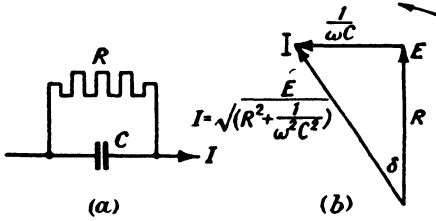

FIG. 162

(a) Capacitance and resistance in parallel.
 (b) Vector diagram for C and R in parallel.

by a capacitance and resistance in parallel, as shown in Fig. 162 (a). When a voltage is applied to such a condenser there will be a pure capacitance current and a leakage current. This leakage current will be represented by the current in the resistance.

Such a circuit will have a power factor in accordance with the relative value of resistance and capacitance. The vectors for these are shown in Fig. 162 (b).

The value of the leakage current will be determined by the quality of the insulation used as the dielectric for the condenser. Therefore the watt loss in the resistance represents the watt loss in the condenser. This watt loss is clearly proportional to the angle δ , which is called the *loss angle*. Therefore if this angle can be measured, the loss can be calculated. Thus

$$W \text{ (loss)} = EI \cos \delta \quad \dots \dots \dots (82)$$

The loss angle is given by

$$\tan \delta = 1/\omega RC \quad \dots \dots \dots (83)$$

where $\omega = 2\pi f$.

The method adopted for measuring this loss angle is by means of the Schering bridge. The connections for this are as given in Fig. 163. The condenser under test is represented by the impure capacitance C_1 . A pure capacitance C_2 is used as a standard for capacitance and energy loss. R_3 is an adjustable non-inductive resistance, and R_4 a fixed non-inductive

resistance shunted by a variable condenser C_4 . The resistance side of the bridge is connected to earth, and the other side to the h.t. terminal of a transformer. G is a vibrating galvanometer controlled by the switch S . It is necessary carefully to screen the various parts and leads to avoid errors due to the effects of extraneous fields.

When voltage is applied to the bridge, the resistance R_3 and condenser C_1 are adjusted until zero deflection is obtained on the galvanometer. The circuit is then represented by four impedances, which may be designated Z_1, Z_2, Z_3 and Z_4 ; the suffixes corresponding to those used for the capacitances and resistances of the bridge.

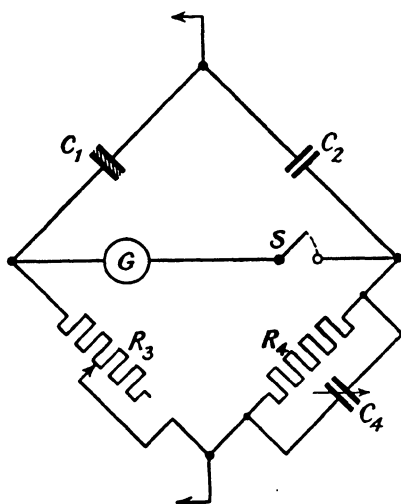

FIG. 163. SCHEMATIC DIAGRAM OF SCHERING BRIDGE

The vectors for the C_1 arm are as in Fig. 164 (a), from which

$$Z_1 = \frac{1}{\omega C_1 \cos \delta} \left/ \frac{\pi}{2} - \delta \right.$$

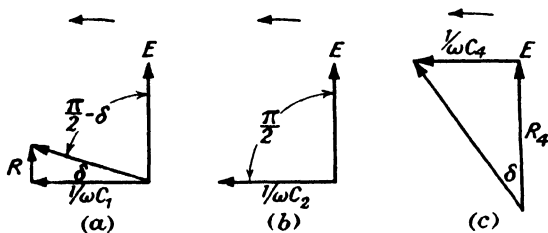

FIG. 164

- (a) Vector diagram for arm $C_1 (Z_1)$
- (b) " " " " $C_2 (Z_2)$
- (c) " " " " $R_4 C_4 (Z_4)$

The vectors for the C_2 arm are as in Fig. 164 (b) from which

$$Z_2 = \frac{1}{\omega C_2} \left/ \frac{\pi}{2} \right.$$

The vector for Z_3 is obviously $R_3 / 0$; whilst the vectors for Z_4 arm are as in Fig. 164 (c) from which

$$Z_4 = \frac{R_4}{\cos \delta} \angle \delta.$$

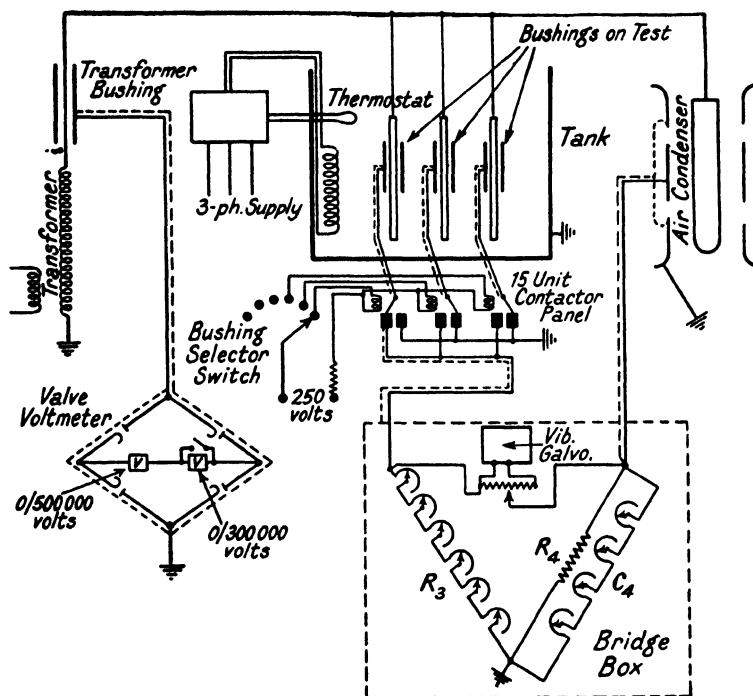

FIG. 165. SCHEMATIC DIAGRAM OF CONNECTIONS OF SCHERING BRIDGE TESTING SET AS USED BY METROPOLITAN-VICKERS CO. LTD.

The condition for balance in the bridge is

$$Z_1/Z_3 \text{ shall equal } Z_2/Z_4.$$

Therefore by substitution

$$\frac{\frac{1}{\omega C_1 \cos \delta} \angle \frac{\pi}{2} - \delta}{R_3 \angle 0} = \frac{\frac{1}{\omega C_2} \angle \frac{\pi}{2}}{\frac{R_4}{\cos \delta} \angle \delta}$$

from which

$$C_1 = C_2 R_4 / R_3 \cos^2 \delta \quad . \quad . \quad . \quad . \quad . \quad . \quad . \quad . \quad (84)$$

The loss angle is $\tan \delta$ which is given from above as

$$\tan \delta = 1 / \omega C_4 R_4 \quad . \quad . \quad . \quad . \quad . \quad . \quad . \quad . \quad (85)$$

A diagram of connections of an actual Schering bridge testing set as used by the Metropolitan-Vickers Co. is given in Fig. 165. From this it will be seen that a number of bushings can be arranged for testing on one set-up; each bushing being chosen for test by the operation of a suitable selector switch. The temperature of the oil in which the bushings are immersed is governed by automatic control from a thermostat.

BIBLIOGRAPHY

- B. G. Churcher and C. Dannatt, *World Power*, May, 1926.
 C. L. Fortescue, *A.I.E.E. Proc.*, Vol. 32.
 W. Huter, *E.T.Z.*, June, 1932.
 W. J. John, *J.I.E.E.*, March, 1932.

CHAPTER XI

BUS-BARS, CONNECTIONS AND THEIR FITTINGS

IN high voltage applications current values rarely reach 800 A., and quite often the size of the conductor has no relationship to the value of the current to be carried.

The outdoor high voltage station has bus-bars that are either in the form of flexible cables strung between strain-type insulators, or else consist of tubular conductors supported on post-type insulators. There are also combinations of these, of which the Bolton conductor may serve as an example. This is, in fact, a stranded cable, of which each strand is a tube of small diameter.

Because of the large clearances required in this class of work, the lengths of these bus-bars and interconnections become somewhat great, and the higher the system voltage, the greater in general does the conductor span become. It is obviously very desirable that the conductors shall not sag too much, bend easily, or break under wind pressure or ice loading conditions; and this requirement becomes so onerous in high voltage schemes that the resulting conductor is the outcome of a design that is controlled by mechanical rather than electrical considerations. In fact, it might be said that the only electrical consideration which affects the conductor diameter in high voltage schemes is that of corona. In Table XVI is given the relationship between conductor diameter and system voltage which will keep the corona loss within commercial limits.

The longest conductor spans in the outdoor station may be made with stranded cable strained between tension insulators. This particularly applies to spans above 25 ft.; below this length the tubular conductor is possible. The circular section for either type is taken for granted, since it is better from the point of view of wind resistance and vibration, as well as of corona.

Strained Conductors. With this type of conductor, the sag is kept within the required limits by stringing the conductor to a given tension. The relationship between sag and maximum tension for flexible stranded cables is obtained thus

$$T_s = (w^2 l^4 / 16 d^2 + w^2 l^2 / 4)^{1/2} \text{ lb.} \quad (86)$$

where d is the sag in feet; l , the span length in feet; w , the weight per foot run of the conductor in pounds; and T_s is the stringing tension, or tension along the conductor, at the point of attachment to the insulator string.

This equation assumes the parabola law, which, although not theoretically accurate is quite close enough for practical problems of this nature. Furthermore, equation (86) does not allow for wind pressure or ice loading. The effect of wind pressure is considered later, but ice loading can be treated by

TABLE XVI
RELATIONSHIP BETWEEN CONDUCTOR DIAMETERS AND SYSTEM VOLTAGES TO KEEP CORONA LOSS WITHIN COMMERCIAL LIMITS

System Voltage, kV.	Minimum Conductor, Diameter, Inches
33	0.250
44	0.250
66	0.375
88	0.500
110	0.625
132	0.750
165	0.920
220	1.275

giving to w the value for the weight of the conductor when loaded with ice to the required thickness. The effect of temperature is such that the tension will be increased by a drop in temperature, and therefore the sag will be diminished; whilst the reverse is true for an increase in temperature. The variation in sag for the different tensions is given by the equation (86); whilst the variation of tension with change in temperature is clearly the result of the expansion and contraction of the conductor material.

If the conductor has been strung to a tension T_s when the temperature was, say, 50° F., and if at this tension and temperature the sag is d_{50} , then the sag that will occur when the temperature is at some other value t is given by the expression

$$d_t = \sqrt{[d_{50}^2 + (3/8) \alpha (t - 50)l^2]} \quad \dots \quad (87)$$

where α is the coefficient of expansion of copper per degree F., which is 0.000095, and l is the conductor span in feet.

At very high voltages, such as 115 kV. and upwards, the

use of ordinary stranded conductor becomes uneconomical, because generally the diameter of the conductor, as fixed by corona limitations, is very much greater than is required for the current capacity. Thus a stranded cable of this diameter would contain far more copper than is required, and in consequence would be costly and unnecessarily heavy. It is in

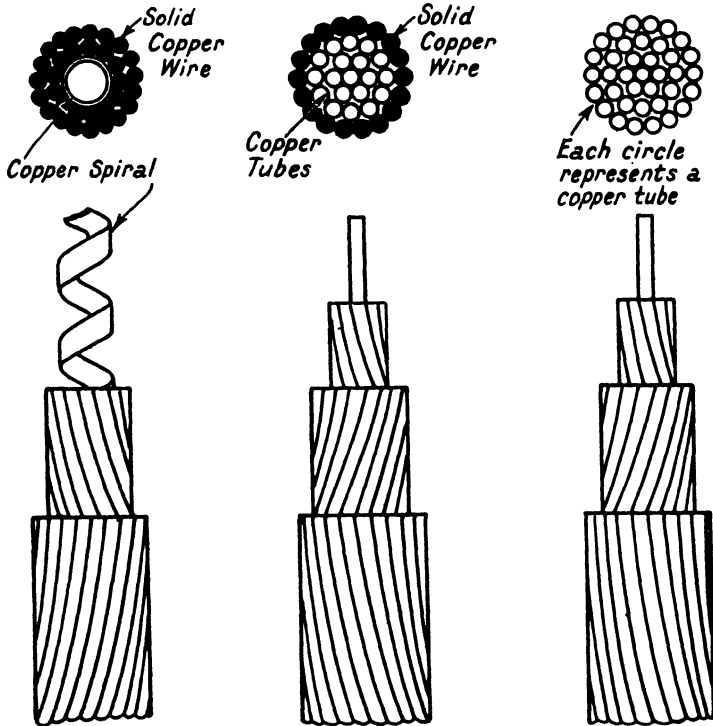

FIG. 166. SPECIAL CABLES FOR HIGH VOLTAGE SERVICE
(Pirelli General Cable Works, Ltd.) *(Thos. Bolton & Sons, Ltd.)*

such cases that the special conductors find their application. For instance, there are the special cables already mentioned. These provide the diameter to suit corona demands, and yet are comparatively light in weight and cheaper than a stranded cable of the same diameter. Fig. 166 shows three such cables, and because of the greater stiffness of the sections of these cables, the sag for a given tension will be less than would be obtained from a stranded cable of comparable dimensions.

In addition to the above there is the steel core aluminium cable which has the advantages of strength, lightness and a current-carrying capacity equal to 60 per cent of that of copper. With this type of conductor, special terminals have to be used, because a copper-aluminium joint between which moisture can penetrate becomes in effect an electrolytic cell, the action of which is to decompose the aluminium element.

† **Tension Insulators.** The straining of a flexible cable for the purpose of using it as a station bus-bar or interconnection involves the use of tension insulators. These are of the same kind as those used on the overhead transmission line. The number of units to be used in the string of such insulators will be governed by the impulse spark-over value that is required at this point of the system. The number of units to give a particular spark-over value can be obtained from Figs. 206 and 207. These numbers of units are for use with suspension strings or tension strings that occur in the run of the conductor. It is the custom to add one more unit to strings that are situated at the end of a conductor. This is because in such positions surge reflections will be greater than at the other points, and therefore increased insulation is warranted.

When these insulator strings occur at each end of a flexible line, as they usually do, their weight has its effect upon the sag of the conductor. To obtain the total sag for such a condition, it is first necessary to calculate the sag for the conductor as given by equation (86). This sag will be that which occurs below the point of suspension at the ends of the insulator strings. The tension that has been put on the conductor to obtain this sag will represent one of the two forces acting on the string of insulators. Actually, such a string of insulators will itself have flexibility, and the correct solution of the problem should take this into account: but for ordinary practical problems it is sufficient to consider the string as a rigid body anchored by a swivel fixing at one end, and under the action of two forces. One of these is a horizontal force which is the horizontal component from the line pull, and the other is a vertical force from the weight of the insulator itself. The value of the horizontal component of the line tension is given by the expression

$$T_H = wl^2/8_d \text{ lb.} \quad . \quad . \quad . \quad . \quad . \quad . \quad . \quad (88)$$

Having thus obtained these vertical and horizontal forces

where δ is the deflection in inches; l , the span length in inches; W , the total weight of the conductor; I , the moment of inertia of conductor section; and E , Young's modulus. Where the deflection is permitted to be greater than the conductor diameter, but not more than, say, twice that diameter, the following empirical equation for deflection may be applied

$$\delta = Wl^3/150 EI \quad (90)$$

The difficulty of calculating for conductor sag is further increased when a conductor of special section is used. The simplest of these special conductors is the copper-clad steel tube. In this it is troublesome to know how to combine the values of I and E for the copper and steel portions. It is, however, quite accurate enough for practical purposes to ignore the copper tube in calculating for the moment of inertia, and to obtain I for the steel tube alone. It is essential, however, that the copper tube be included when calculating W , the weight of the conductor, and a closer result will be obtained if the copper tube is included in the calculation for the value of E . The latter is effected by taking the value of E for the composite tube as being proportional to the relative sectional areas of the copper and steel. Thus, suppose the area of the copper tube be A and that of the steel tube a , and suppose E_c and E_s be the moduli of copper and steel respectively, then the modulus for the combined tube can be taken as

$$E = (AE_c + aE_s)/(A + a) \quad (91)$$

To enable the above to be applied without further reference, Table XVII gives the required physical values for copper, steel, aluminium, etc.

TABLE XVII

Material	Weight lb. per in.	Coefficient of Linear Expansion per ° F.	Value of E (Young's Modulus)
Copper	0.32	0.0000095	15×10^6
Steel	0.28	0.00007	28×10^6
Aluminium	0.097	0.0000126	11×10^6
Ice	0.0324	—	—

diameter, when the wind velocity is 30 m.p.h. The product $V \times D$ is $1.25 \times 30 = 37.5$, and from the curve a in Fig. 167 the value of κ corresponding to $VD = 37.5$ is found to be 0.00302. Therefore the pressure on the conductor per sq. ft. of projected area is

$$P = 0.00302 \times 30^2 = 2.7 \text{ lb.}$$

For stranded cables the results of experiment are not so certain; but for the value of the wind resistance coefficient κ for such cables, curve (b) in Fig. 167 represents a suggested maximum limit, which will probably be quite close enough for the lengths of conductors that are to be dealt with in high voltage station lay-out. For the more exact treatment of this subject, the reader cannot do better than refer to the works of W. B. Woodhouse: "Overhead Electric Lines," *J.I.E.E.*, Vol. 67, 1929.

Vibration. In addition to the stress imposed upon conductors by wind pressure, there is also that which occurs from vibration, because when wind blows across a conductor the result is not only a direct mechanical pressure on the conductor, but also there is a tendency to set the conductor in a state of vibration. Such vibration can be of two kinds: one which is in the nature of stationary waves of relatively high frequency and small amplitude, and one which takes the form of travelling waves. The last-named occurs from such causes as a sudden change in the mechanical loading at one point in the line—say the falling from the line of a quantity of ice or snow due to thaw. But with the conductor lengths that are used in outdoor stations, travelling waves are practically non-existent, and it will suffice for this class of work if attention is confined to the vibration of stationary waves. It is impossible here to consider the reason why a wind blowing transversely across a conductor should cause it to vibrate, but it is known that, not only is this true, but that the velocity of the wind, the shape of the conductor, and the nature of the surface each has its effect upon the degree of vibration that results. For instance, the vibration of a smooth surfaced cylinder may be greater than that which occurs under the same circumstances but with a rough surfaced cylinder.

Any conductor supported between two points will have its own natural frequency of vibration and harmonic. The former is dependent upon the tension on the conductor, whilst the

harmonic is a function of the conductor length. Therefore, as the conductor length and tension vary with change of temperature, its natural frequency and harmonic will vary accordingly. It is when the frequency of the vibration caused by a wind across the conductor coincides with the natural frequency of that conductor under the conditions prevailing that trouble may occur due to a rapid increase in amplitude. The condition is akin to that of resonance in an electrical circuit, and means should be taken to prevent it. Quite an amount of damping is provided by the stiffness of the conductor itself, but for long unsupported lengths something additional is required.

Varney gives the relationship between the alternating wind

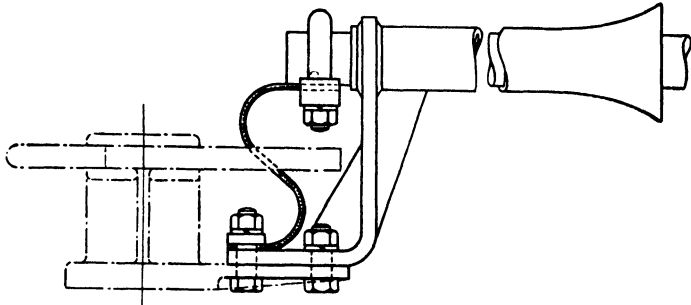

FIG. 168. CONDUCTOR SUPPORT AND VIBRATION DAMPING DEVICE

pressure, and the wind velocity and conductor diameter by the equation

$$f_w = 2.22 v/d \text{ cycles per sec.} \quad (94)$$

where f_w equals the frequency, v is the wind velocity in ft. per sec., and d is the conductor diameter in inches.

The frequency of vibration on the n th harmonic for a conductor of span l is given by the equation

$$f_n = \frac{n}{2l (Tg/w)^{1/2}} \text{ cyc.} \quad (95)$$

It is clear that a condition of resonance will result when

$$f_w = f_n.$$

In general it seems that the maximum vibration comes from comparatively light winds.

In Fig. 168 is given one damping device that can be used for the purpose of reducing vibration on the bus-bar conductors of an outdoor station. This will no doubt suffice to indicate the

general lines on which such damping can be effected. The conductor in question is of tubular section with large outside diameter and thin wall, which gives a light stiff mechanical section and meets corona and current requirements adequately. Extending over each end of the conductor for about 2 ft. is a bell-mouthed tube which fits the conductor tube very closely. The conductor has free axial movement within the bell-mouthed tube so that expansion and contraction are not restricted. The damping is effected by the interference between the frequencies of the end tubes and that of the conductor. It is not claimed that this device entirely destroys vibration, but that it prevents the damage caused by resonant vibration. This device has also the advantage that it provides a support for each end of the conductor, so that in effect the conductor span is reduced from the distance between the post support insulators to that between the bell mouths of the damping tubes.

A tube of a somewhat similar kind, although not for the purpose of damping, is used to support flexible jumper connections that are required to pass clear of the earthed end of an insulator post. In this case the stiffness of the tube constrains the flexible conductor to a path that ensures that the necessary electrical clearance is maintained. An example of the application of this is given in Fig. 14.

Semi-Strained Conductors. This type comprises special conductors designed for the purpose of being strained between post insulators of stout design, and the former having a section with a relatively large modulus. The special conductors shown in Fig. 166 are examples of these. To calculate the sag of a conductor of this nature for a given tension is very difficult, because the conductor, having neither the rigidity of a beam nor the flexibility of a wire, obeys neither the beam formula nor the parabolic law. Each such special conductor is a law unto itself, and the moment of inertia of each special section must be obtained before any attempt can be made to calculate for the sag.

When the conductor is required to be very long, it is usual to support it *en route* by post or suspension type insulators. By this means the tension may be lessened, because the sag is taken up by the insulator supports. These supports may be mounted on the steelwork structure that carries the isolating switches, etc.

Actually, the design of outdoor station bus-bars is a question

of economics as well as of technical considerations. For instance, it may prove cheaper in certain cases to use a small bore

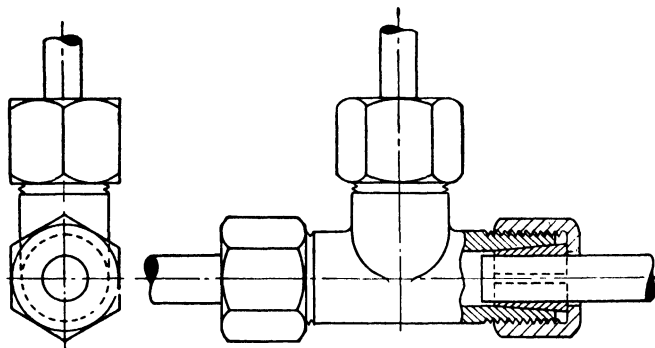

FIG. 169. CONE GRIP TYPE OF CONNECTION

tube with intermediary post supports than to use a larger tube in one span. The remarks in these last two paragraphs apply with equal force to the strained and tubular conductors in the preceding sections.

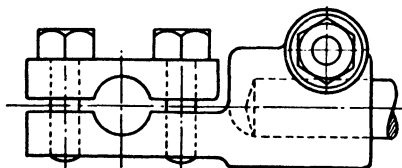

FIG. 170. CLAMP TYPE TERMINAL

Terminals. The ordinary sweated terminal so common in indoor electrical work is not suitable for outdoor use. There are

two main reasons for this; one is the inability of the soldered joint to stand up to a continuous tensile load, and the other is

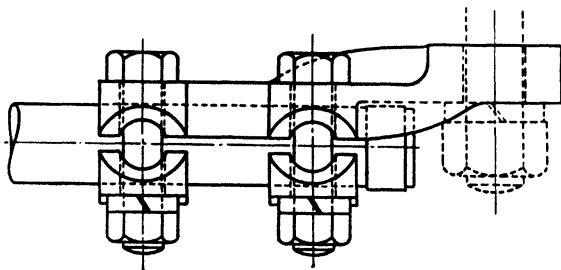

FIG. 171. TERMINAL CLAMP FOR STRANDED CABLE

the uncertainty of the joint being properly made when the work has to be carried out in the difficult positions that often

occur in outdoor high voltage work. Terminals for outdoor use therefore conform to a few special types, and of these the cone grip and clamp types shown in Figs. 169, 170 and 171 are good examples. The clamp type is perhaps the more popular because it is generally cheaper and provides a positive grip. The cone clamp on the other hand depends for its efficiency upon good workmanship in manufacture, but is undoubtedly of neater appearance.

In addition to these, there are terminals that are designed to allow a limited movement of the conductor, and so provide for the effects of expansion and contraction. An example of this type is given in Fig. 172, and it will be seen that, whilst solid electrical connection is maintained between terminal and conductor by means of the shunt, the conductor is free to slide within the terminal for a limited distance. This type of terminal generally finds its application at one end of a long conductor, the other end of which terminates in a clamp type of terminal; thus the conductor is held rigidly at one end and supported at the other with a certain freedom of movement.

Then there is the special terminal that is required to connect an aluminium conductor to a copper or brass terminal. As previously explained, the junction of these two metals must be protected or electrolysis will occur, to the deterioration of the aluminium. An example of this type is shown in Fig. 173.

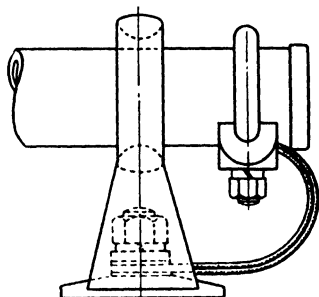

FIG. 172. EXPANSION-TYPE CONDUCTOR SUPPORT

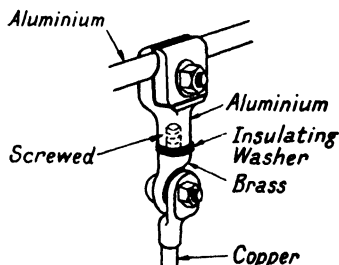

FIG. 173. TERMINAL USED FOR CONNECTION BETWEEN COPPER AND ALUMINIUM

BIBLIOGRAPHY

P. J. Ryle, *J.I.E.E.*, Vol. 69, 1931.

W. B. Woodhouse, *J.I.E.E.*, Vol. 67, 1929.

CHAPTER XII

LIGHTNING SURGE PROTECTION

Lightning. The modern theory of lightning was born about the beginning of the present century, when it became known that the atmosphere was subject to ionization. About that time Prof. C. T. R. Wilson proved that air normally contains a number of positive and negative ions, and that the conductivity of the air is a measure of the number of ions present, and of their mobility. When the air becomes laden with particles of dust or moisture, the free ions become attached to these particles, and as the mobilities of the particles are much lower than are those of the free ions, the conductivity of the air is thus considerably reduced.

In a cloud, which is but an accumulation of water particles in suspension, the conductivity is only about one-hundredth part that of ordinary clean air. It has long been known that if water particles are broken up, the resulting smaller particles become positively ionized, whilst the freed electrons attach themselves to other water particles so that the latter become charged negatively. On this basic fact two entirely different theories have been put forward to explain how large accumulations of electric charge become formed in different parts of a cloud; one part becoming negatively charged and the other part positively. When the electric stress between the two parts of the cloud or between two oppositely charged clouds, or between a cloud and the earth, attains a certain minimum value, a spark will develop between the opposite poles and result in the familiar discharge called lightning. The point of origin of the discharge appears to be the negative pole, which is in support of Prof. Wilson's theory of charge separation, but it must be understood that the theory of formation of the spark is still in a state of flux. Most probably the lightning flash originates at the negative pole of a cloud, and a streamer starts from that pole, and proceeds to earth, or to another cloud, with or without any evidence of branching of the discharge. This so-called *leader stroke* is then followed up by the so-called *main stroke* which proceeds from the positive pole back to the negative pole, sometimes, but not always, exhibiting

branching. Both these kinds of strokes can be imitated in the laboratory. Thus the direction of branching or forking is not the valuable criterion of polarity that it was once thought to be.

Lightning strokes are in general unidirectional. A cloud loses its charge, or part of its charge, by a simple discharge occurring between the cloud and earth, etc. The discharge current rises to a maximum with great rapidity and then decreases to zero. Due, however, to the inductance and capacity of the discharge path, there may result, under given conditions, oscillations, which will be superimposed on the unidirectional wave of the main discharge. An example of such a discharge is shown in Fig. 174.

The next important factor in regard to the lightning flash is

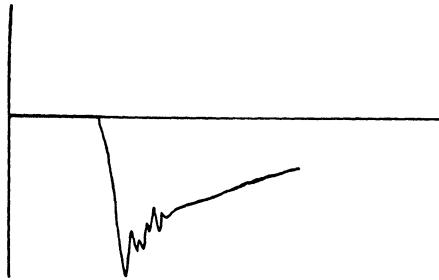

FIG. 174. EXAMPLE OF A LIGHTNING SURGE, SHOWING SUPERIMPOSED HIGH-FREQUENCY RIPPLES

the order of magnitude of the energy released. Prof. Wilson takes twenty coulombs as the average value of the charge released in a single flash, and this corresponds, with cloud potentials of the order of 500 million volts, to a release of energy of 10^{10} joules. The duration of the discharge varies between 5 and 1 000 μ sec.; so that it will be seen that discharge currents of 20 000 amperes are common.

These values refer to the complete discharge. The energy and current in one of the branches will obviously be smaller.

If a conductor in the form of a transmission line be located beneath a cloud that is carrying a charge Q , and is at a height of H metres above the ground, there will be bound on the line a charge of magnitude

$$q = \frac{2h Q}{H \log_e (2h/a)} \dots \dots \dots (96)$$

where h is the height of the line above the ground, and a , the radius of the conductor. If the cloud then discharges itself completely, the charge previously bound on the conductor will be released, and the energy so liberated will travel along the conductor until it becomes finally transformed into heat. The value of this energy is given by the expression

$$W = \frac{3\pi Q^2 h^2}{8H^3 \log_e (2h/a)} \quad \dots \quad (97)$$

Under typical clouds the bound energy on the conductor might be, say, one-millionth part that of the energy on the cloud.

From equations (96) and (97) it will be seen that the height of the line governs the charge and energy induced on the line

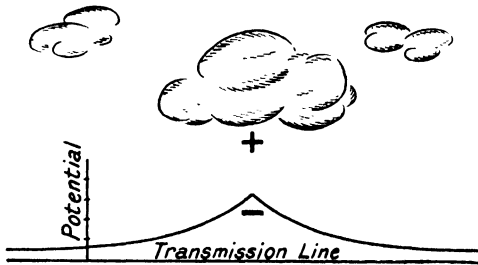

FIG. 175. SHOWING EFFECT OF A CHARGED CLOUD ON A TRANSMISSION LINE

by the cloud. In addition to the above there is the *fine weather effect*, or the electrical pressure gradient due to the atmosphere itself, which reaches a maximum near the surface of the earth and diminishes as the height increases. As the effect of this on the lightning discharge is not apparent, it is not proposed to consider it further.

In Fig. 175 there is shown diagrammatically the effect of a charged cloud on a line. It is possible, of course, for a cloud to become suddenly charged as the result of a flash to it from another cloud, and the resulting voltage gradient to earth may then be as much as 50 kV. per ft. This would mean that a line 20 ft. high above earth would have as suddenly impressed upon it a pressure surge of a million volts.

From equation (96) it is evident that the distribution of the charge induced on a line is controlled by the distribution of the charge on the clouds. The latter may be of infinite variety

and it is therefore illogical to consider any one distribution more than another. Even so, for the purpose of example, consider the following case. A transmission line 15 metres high and with conductors of 0.5 cm. radius, passes beneath a cloud three kilometres above the ground. The energy induced on this line is obtained from equation (97), and is found to be 4×10^{11} ergs, if the charge on the cloud be taken as 20 coulombs. The charge q induced on the line is found from equation (96) to be 0.023 coulomb. When the cloud discharges in the lightning flash this energy is released and starts two waves, one in each direction along the line. Each wave will be of energy 2×10^{10} ergs or 2×10^3 joules. Suppose the duration of the discharge to be 1 000 μ sec., then the energy of the surge can be represented as

$$2 \times 10^3 / 10^{-3} = 2 \times 10^6 \text{ watts.}$$

The induced charge on the line was found to be 0.023 coulomb, and, as the time of discharge is 1 000 μ sec., the current will be 23 amperes. Therefore the mean voltage of the discharge will be $2 \times 10^6 / 23$ or 100 000 volts, and if, for simplicity, we assume a wave of regular triangular shape, the peak value of the voltage surge will be of the order of 200 000 volts.

Travelling Waves. From whatever cause created, a surge is the movement of a charge along the conductor, and, because of the impedance of the conductor, is always associated with a pressure surge of the same form. The shape of the surge or wave at any moment is governed by the circumstances that control the distribution of the charge beneath the cloud, and by the subsequent history of the surge. The surge produced by a direct or induced stroke may have an almost vertical front. Due to the fact that in travelling along the line the surge encounters not only a surge impedance produced by distributed constants, but also a series of lumped capacitances represented by line insulators, all of which must be charged up, the front of the wave will become sloped back. This effect is increased by the fact that the peak of the wave will travel more slowly than the foot, due to corona loss. The lumped capacitances of oil circuit-breaker and transformer bushings will also tend to slope the wave front. The wave may be conveniently represented by two parts; the front, which is that part from the beginning of the wave to its peak; and the tail, which is that part from the peak of the wave to the end.

As the rate of rise of voltage is usually much more rapid than the subsequent diminution, surges are frequently treated mathematically as having a rectangular shape; i.e. a wave front of zero length, and a wave tail of constant amplitude and infinite length. This would very approximately be similar to an actual wave of, say, a $\frac{1}{2}$ μ sec. wave front, and a 1 000 μ sec. wave tail. Actual travelling waves on transmission lines have wave fronts varying from 0.1 to 20 μ sec., and wave tails varying from a few to many hundred microseconds.

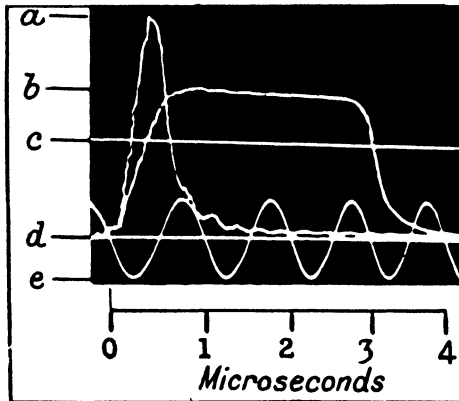

FIG. 176. EXAMPLES OF DIFFERENT FORMS OF IMPULSE WAVES

The above oscillograms were taken by Metropolitan Vickers with a Cathode Ray Oscillograph.

But the shape of the actual wave experienced on the transmission line must not be considered to be the precise mathematical shape that is used in the laboratory. In Fig. 176 there are shown a few examples of different waves.

Reflection. Consider a transmission line with one end open, and suppose from any cause a wave of voltage is impressed upon it. This wave will travel along the line and, upon reaching the open end, will be reflected. A similar phenomenon may be observed when waves in water meet a vertical surface. Let E be the value of the original voltage wave; upon reflection the value will become $2E$. This is because the forward progress of the wave is stopped by the open end of the line, and so the wave will compress upon itself for a period, until the forward energy has been converted. The pressure will then exert itself

in the reverse direction. The occurrence is somewhat analogous to that of a ball thrown at a wall. Upon striking, the kinetic energy of the ball is transformed into static energy of pressure within the ball, which latter is momentarily compressed. The

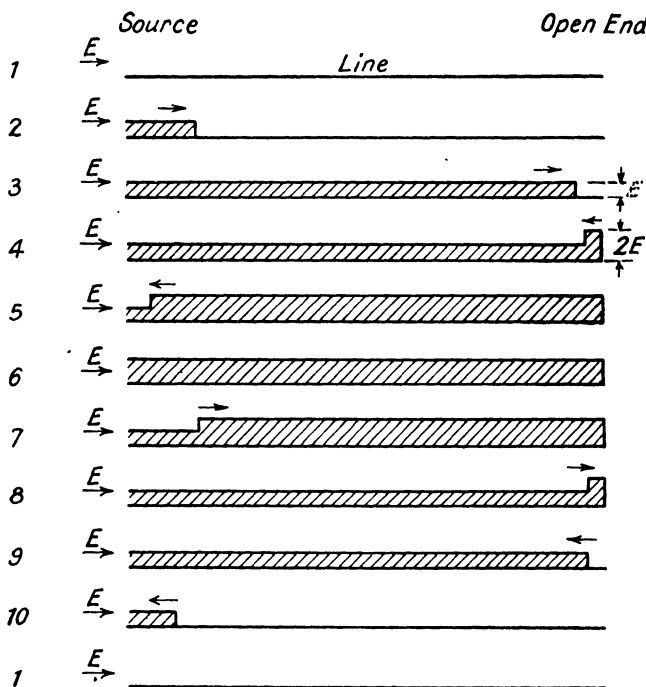

FIG. 177. EFFECT OF VOLTAGE REFLECTIONS ON AN OPEN-ENDED TRANSMISSION LINE

Sending end is assumed to be maintained by supply source at a voltage E

energy of this pressure is then exerted to move the ball in the reverse direction.

In Fig. 177 there are shown the effects of voltage reflections on an open-ended line. From this it will be seen that the oncoming surge E reflects and travels back to source at the value $2E$. The source, however, is assumed to be maintained at E by machines, etc. In order to meet this condition, the second reflection will be $-E$, which added to $2E$ of the first reflection, gives the required value of E at the source terminals. This second reflection of $-E$ will travel on to the open end

and in doing so will reduce the previous value $2E$ to E . At the instant of reaching the open end, the values are E and $-E$; therefore the third reflection is a wave of zero voltage back to the source. After this the sequence is repeated as shown in the figure by the second outgoing wave of $+E$. From the resistance of the line, the wave suffers continual energy transformation or attenuation, during its travels, so

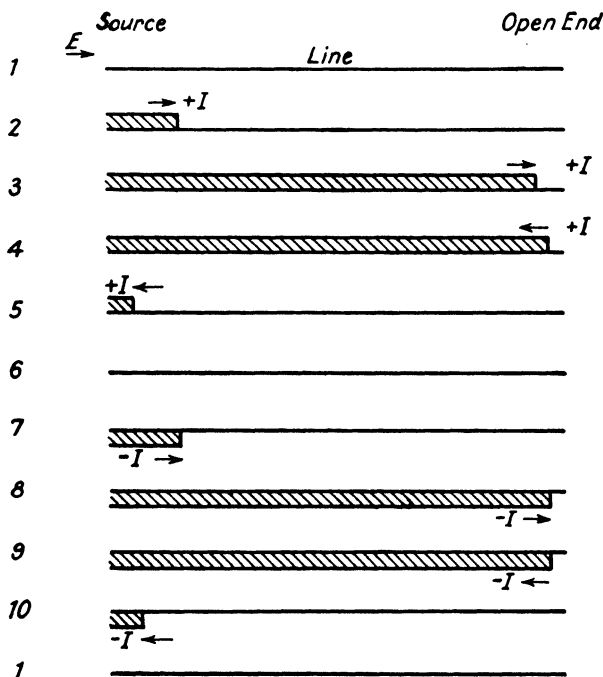

FIG. 178. EFFECT OF CURRENT REFLECTIONS ON AN OPEN-ENDED TRANSMISSION LINE

that the amplitudes of the reflections are ultimately reduced to zero.

Fig. 178 shows the corresponding reflections for current waves along an open line. In this case it is clear that the net current value at the line end must be zero; therefore the reflected current is $-I$. The remainder of the figure should be self-explanatory from what has already been given. Thus if I is the surge current in the original wave, and $-I'$ the same in the reflected wave, then $I + (-I') = 0$; which is the

required condition. Again, if E is the surge voltage, and Z the surge impedance of the line, then $I = E/Z$.

Similarly, $-I' = E'/Z$; where E' is the reflected surge voltage, or

$$\left. \begin{aligned} E &= IZ \\ E' &= I'Z \end{aligned} \right\} \dots \dots \dots (98)$$

Numerically, $I = I'$. Therefore, from equation (98), $E = E'$.

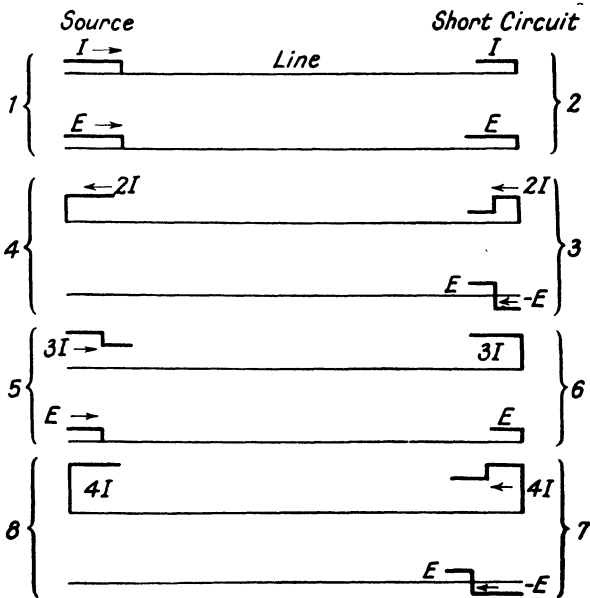

FIG. 179. VOLTAGE AND CURRENT REFLECTIONS THAT OCCUR WHEN THE WAVES MEET A SHORT CIRCUIT

In Fig. 179 are shown the reflections that occur when traveling waves meet a short-circuit. Here, the voltage must be zero; therefore the reflected wave is $-E'$, and is equal in magnitude to E , the original wave. Or, $E = -E'$; which gives the required condition, $E + E' = 0$.

The relations between surge voltage, current and impedance still hold good in accordance with equation (98). Therefore the first reflected current at short-circuit can be deduced from equation (98) to be equal to $2I$. After that the current increases by I for every additional reflection, as shown in the figure.

The next important case is when a travelling wave meets a point of discontinuity; say a change in impedance such as is represented at the junction of an overhead line with an underground cable. Let the surge impedance of the air line be Z_A and that of the cable Z_B , and the corresponding suffixes be used for the other quantities. From what has gone before, it will be understood that the instantaneous value of the voltage impressed on the junction by the oncoming wave is the sum of the oncoming wave and the reflected wave. Or, if E_A is

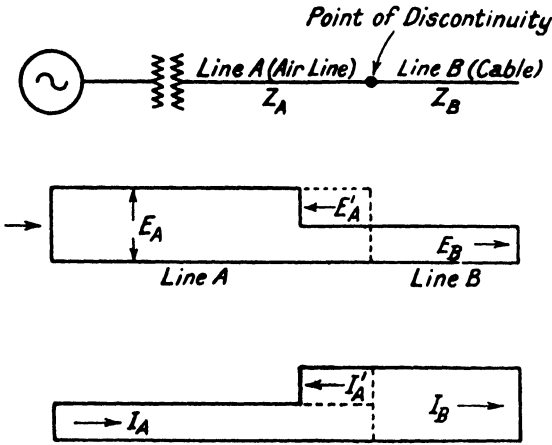

FIG. 180. EFFECT OF TRAVELLING WAVES MEETING A POINT OF DISCONTINUITY
Line A is assumed to have a higher surge impedance than line B.

the oncoming wave, E'_A the reflected wave, and E_J the voltage at the junction, then

$$E_J = E_A + E'_A \quad \dots \quad (99)$$

E_J equals the voltage transmitted to line B.

Now the total current in the two lines must be identical at the point of junction. Therefore, if I_B represents the current in line B, then $I_B = E_J/Z_B$.

Also, $I_A = E_A/Z_A$ and the reflected current, $I'_A = E'_A/Z_A$. But this reflected current is negative, therefore,

$$\frac{E_B}{Z_B} = \frac{E_A}{Z_A} - \frac{E'_A}{Z_A} \quad \dots \quad (100)$$

By combining equations (99) and (100) it will be found that

$$E_B = \frac{2Z_B}{Z_A + Z_B} \cdot E_A \quad (101)$$

$$I_B = \frac{2Z_A}{Z_A + Z_B} \cdot I_A \quad (102)$$

The reflected voltage and current in line A is

$$E'_A = \frac{Z_B - Z_A}{Z_A + Z_B} \cdot E_A \quad (103)$$

$$I'_A = \frac{Z_A - Z_B}{Z_A + Z_B} \cdot I_A \quad (104)$$

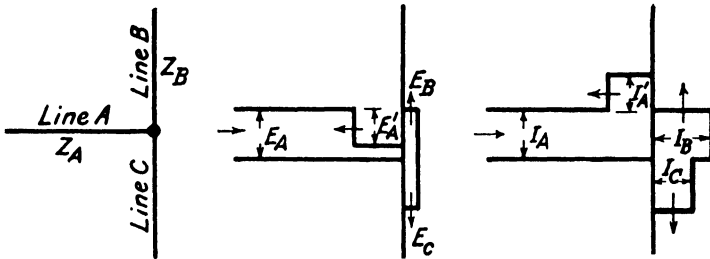

FIG. 181. EFFECT OF TRAVELLING WAVES MEETING A "TEE" JUNCTION OF LINES

Line C is presumed to leave a higher surge impedance than line B.

These reflections are shown diagrammatically in Fig. 180 in which line A is assumed to have a higher surge impedance than line B. The above holds good, not only for the change of impedance due to the junction of an air line and cable, but for the change of impedance from any cause; for example, that due to the connection of the high voltage winding of a transformer to a line.

In the case of a "tee" line the transmitted and reflected voltages are given by the following equations. See Fig. 181.

$$E_B = E_C = \frac{2Z_B Z_C}{Z_A Z_B + Z_A Z_C + Z_B Z_C} \cdot E_A \quad (105)$$

$$E'_A = \frac{Z_B Z_C - Z_A Z_B - Z_A Z_C}{Z_A Z_B + Z_A Z_C + Z_B Z_C} \cdot E_A \quad (106)$$

From equations (103) and (104) it should be noted that if $Z_A = Z_B$ there will be no reflected wave, and consequently no

disturbance. The surge impedance of a line is equal to $Z = \sqrt{L/C}$. For overhead lines it varies from about 400 to 600 ohms. For cables the value of C is greater than it is for air lines; therefore Z for cables is smaller; 40 to 60 ohms approximately.

The velocity of propagation for the voltage and current surge equals, $V = 1/\sqrt{LC}$; which for air lines is nearly equal to 3×10^{10} cm. per sec. For cables it is about half this value, dependent upon the dielectric constant of the cable insulation.

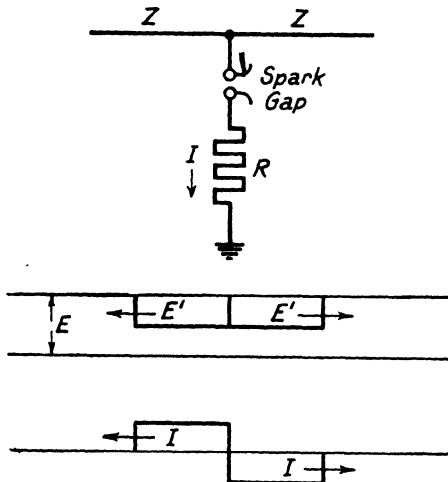

FIG. 182. TRAVELLING WAVES PROPAGATED ALONG THE LINES AS THE RESULT OF THE DISCHARGE OF A SPARK GAP CONNECTED TO THE LINE

The attenuation of the travelling waves is given by the equations

$$E_x = E e^{-0.5(R/Z + GZ)x} \quad . \quad . \quad . \quad . \quad . \quad . \quad (107)$$

$$I_x = I e^{-0.5(R/Z + GZ)x} \quad . \quad . \quad . \quad . \quad . \quad . \quad (108)$$

E and I are the values of the voltage and current respectively at some arbitrary point, and E_x and I_x the corresponding values at a point a distance x from this datum point. R is the resistance; Z , the impedance and G the conductance or leakance. Again, it should be noted that the attenuation in cables is more rapid than in air lines, due to the fact that G is higher for cables than for air lines.

The above does not allow for "skin effect" by which the resistance varies according to the frequency.

The Lightning Arrester Function. Consider now the waves propagated when a spark gap discharges, since this is the first function of most arresters. Suppose E to be the voltage of the line before discharge, and suppose R to be the value of resistance in series with the gap. Then upon discharge let the current that flows be equal to I . Therefore the voltage drop across the gap and resistance is, say, RI , and the voltage of the line is at this point reduced from E to a voltage equal to RI . In consequence a wave of voltage is propagated in both directions along the line, of value $E' = E - RI$. (See Fig. 182.) The current is equal to $I = 2E/(Z + 2R)$.

From the foregoing it may be deduced that when a pressure

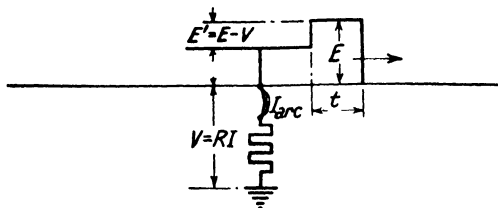

FIG. 183. EFFECT OF TIME-LAG OF DISCHARGE GAP ON WAVE

The period of time-lag is represented by t , and during this time the wave travels on undiminished. After time t the value is decreased from E to V , but the front part of the wave, as represented by t , continues at the pressure E .

surge reaches a point of discontinuity there is a reflected wave and a transmitted wave, and that if the surge comes from a line of higher to one of lower surge impedance, the transmitted wave will be of reduced pressure; whilst the transmitted current wave will be increased. Again, if the point of discontinuity be a tee junction of lines, the transmitted pressure waves will be equal along the other two branches of the tee, although the transmitted current waves will be in proportion to the surge impedances of those branches. In other words, the energy of the surge will split up at the junction in proportion to the surge impedances of the branches.

The case of a discharge gap that has a time-lag should be particularly noted. During the time represented by the lag the wave will travel on undiminished, and when the gap does discharge the transmitted wave will be of shape somewhat as shown in Fig. 183. Thus any insulation that the transmitted

wave reaches will be submitted to the full force of the surge for the period equivalent to the time lag.

The function of the lightning arrester is to absorb the energy of the surge and to reduce the value of the transmitted pressure wave. An arrester circuit to earth necessarily has resistance; also, when such an arrester is connected to a line, there results the condition of a tee junction. It then follows that the energy absorbed from the surge by the arrester will be a function of the arrester resistance. But, the value of the transmitted pressure wave will also be a function of the resistance of the arrester circuit. Thus, if no resistance were in the arrester circuit, the line voltage would be reduced to zero when the gap

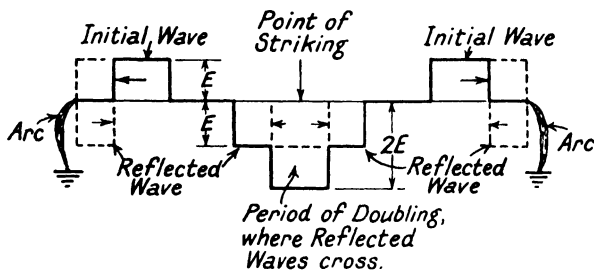

FIG. 184. EFFECT OF DISCHARGE TO EARTH WITH NO RESISTANCE IN CIRCUIT

The wave is 100 per cent reflected, and where the reflected waves cross there is a doubling effect giving 200 per cent line stress (except for the line losses).

discharged, and there would be a 100 per cent reflected negative voltage wave. There would also be a reflected current wave equal to twice the incoming surge current.

The reflected voltage wave would restress the line after it passed the tail of the incoming surge, and, if there were a similar arrester condition at the other end of the line, there would be a 200 per cent voltage on the line where these two reflected waves crossed. See Fig. 184. Therefore, although the surge would not reach the transformers under such conditions, the stress on the line would be doubled, and spark-over on the insulators almost certain.

Gap design, then, must be considered, and with point gaps the time-lag is important. For instance, if a point gap be set to spark over at E volts for minimum value on the tail of the wave, the instantaneous spark-over value is found to be about $2E$. Hence, if a steep-fronted wave of $2E$ occurs, this

will be the value of the wave transmitted to the transformer. The minimum spark-over voltage desirable on a 132 kV. system with solidly earthed neutral is, say, 400 kV. to earth. Yet, with a point gap, the instantaneous peak voltage that can be reached on the gap before breakdown is 800 kV. approximately, and this will be passed on to the transformer. (See Fig. 185.)

It would seem that a high resistance would absorb the maximum energy and so meet the first requirement. But this is not so, since R , the resistance value, determines the current. There is an optimum value of R that will give the maximum energy absorption; obtained thus. Let I equal the arrester current,

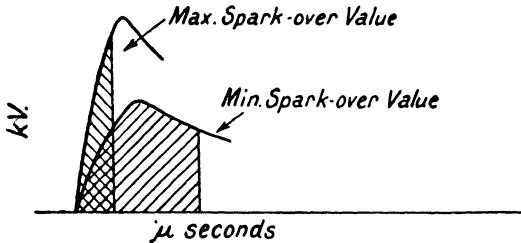

FIG. 185. WAVE SHAPES THAT GIVE MAXIMUM AND MINIMUM SPARK-OVER VALUES

Z equal line surge impedance, R the arrester discharge path resistance, and E the applied surge voltage. Then, energy of discharge equals I^2R .

Arrester current equals $I = 2E/(Z + 2R)$.

Therefore energy = $4E^2R/(Z + 2R)^2 = 4E^2R/(Z^2 + 4R^2 + 4ZR)$.

To be a maximum

$$\frac{d}{dR} \cdot \frac{R}{Z^2 + 4R^2 + 4ZR} \text{ must equal } 0.$$

Whence

$$R = Z/2$$

or R (optimum) equals 250 ohms approximately for a normal line.

A spark gap fitted with such a value resistance would have maximum efficiency in absorbing energy, but would pass on too high a voltage wave for high discharge current values.

Consider an arrester of the type to keep the value of the

transmitted wave as low as possible. The ideal in this case would be an arrester with a characteristic which maintained the transmitted wave to a value but slightly in excess of the peak value of the maximum line voltage. The volt-ampere characteristic curve for this is shown in Fig. 186, from which it

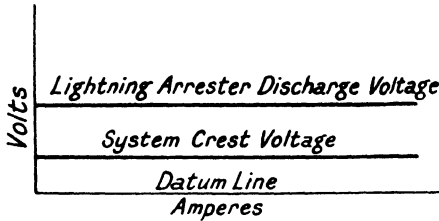

FIG. 186. IDEAL CHARACTERISTIC FOR AN ARRESTER THAT WOULD MAINTAIN THE TRANSMITTED VOLTAGE WAVE AT A GIVEN VALUE

will be seen that, although the surge current through the arrester increases, the arrester voltage is kept constant. Such an arrester would require its impedance path to vary inversely as the current.

Now consider the other type of arrester, one in which the

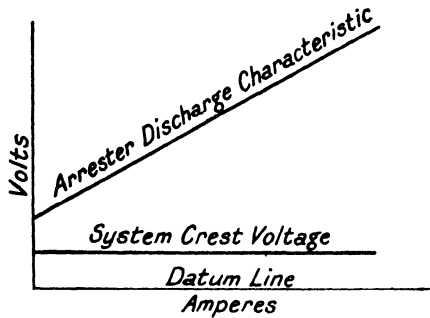

FIG. 187. CHARACTERISTIC VA. CURVE FOR AN ARRESTER THAT WOULD EFFECT MAXIMUM ENERGY ABSORPTION

maximum energy absorption is effected. The VA. curve for this is shown in Fig. 187, and here it is seen that the voltage across the arrester increases rapidly with increase in surge current.

With the first type of arrester the voltage surge would be completely reflected; so that, although the passage of a transmitted surge would be prevented and damage to plant thereby

avoided, the pressure surge would not be eliminated from the line. Such a surge would be left to travel backwards and forwards along the line, assuming the same conditions at both ends, until breakdown of the line insulation occurred, or the surge was absorbed by the line resistance.

An arrester of the second type would relieve the line of the surge voltage, but in so doing would transfer it on to the plant, to which it may do more serious damage than that caused by the breakdown of line insulation.

The ideal arrester then would seem to be one that is a combination of the above, but with a rather greater proportion of the characteristic of the first mentioned.

In Chapter IV it is shown that the breakdown voltage of insulation depends upon the frequency, and that at high frequency a higher voltage stress is permissible without damage than at low frequency. A line surge is generally represented by a single wave, and strictly has no frequency. It is, however, sometimes loosely referred to as being equivalent to a high frequency because of its short duration. The difference between the breakdown voltage value of insulation subject to high frequency and that of insulation subjected to an impulse wave is due entirely to the fact that in the former case the voltage impacts on the insulation are sustained, whereas the impulse represents but a single impact. It follows, then, that the breakdown value for an impulse will be higher than that for a high frequency train, and higher still than that for normal frequency voltage. Therefore it is permissible to allow the transmission of a wave past an arrester of higher voltage than that of the system. This acceptance of such a voltage rise across the arrester enables the arrester to conform to the second principle, and absorb energy. On the other hand, there is a limit to the value of the transmitted wave that will do no damage, the value of which limit depends on the duration of the surge, as represented by the shape of the wave. The arrester must be certain to keep the transmitted wave below this critical value. Because of the possibility of surges with differing wave fronts and tails, it is not practicable to give a fixed value to this limit, but when the arrester discharges the voltage may generally be allowed to increase to two and a half times normal peak value; after which a horizontal VA. characteristic should be maintained.

Because of the discharge gap that is placed in series with most

arresters, there will be momentarily a higher voltage than 2.5 times across the arrester, until this gap breaks down. It is considered that the discharge time-lag of a properly designed gap is so short that the correspondingly brief application of this higher voltage is not detrimental. Such a gap also assists in preventing the flow of power current at line voltage being maintained after the surge has passed.

TYPES OF ARRESTERS

There is a number of types of arresters, some of which may fulfil the above requirements. Two very well known ones are the "Auto-valve" and the "Thyrite."

The Auto-Valve Arrester. The Auto-Valve arrester is based on the principle that current must be passed freely when the voltage across the arrester exceeds a given value, called the *breakdown value*, but must cease when the voltage has dropped below another value. This latter value is known as the *cut-off voltage*.

The breakdown voltage is not necessarily the highest voltage that can appear across the arrester, although it is preferable that it should be. The ratio of the maximum voltage across an arrester to the cut-off voltage is the *voltage ratio of the arrester*.

The Auto-Valve arrester is made up of a series of cylindrical blocks placed one on the other, and housed in a porcelain casing. The material of the block or element is very carefully chosen for reasons that will be given later. The thickness of the elements depends upon the voltage for which they are to be used, and the cross-section is according to the current they are to carry. The flat surfaces of the elements are copper sprayed for contact, and the cylindrical surfaces are cemented to prevent surface creepage. The number of such elements in a stack is fixed by the voltage of the service on which the arrester is to be used. A discharge gap is placed in series with the stack of elements.

Now it is desirable that the voltage ratio of an arrester should be small, thereby indicating that the arrester will discharge at a voltage but little in excess of that at which it will cut-off the discharge. As already stated, this may be as low as 2.5 : 1. Also, it is desirable that as the surge current through the arrester increases, the voltage shall remain fairly constant, and this suggests a negative resistance coefficient for the material of the elements of the arrester.

How these elements comply with these conditions, the following theory will explain. It is known that there are always some free electrons present in a gas, and that these are all-important in the mechanism of spark discharge. When a potential difference exists across a pair of electrodes, there will be a drift of "free electrons" as a result, and, as the p.d. increases, so will the drift increase. When the p.d. reaches a certain value, dependent upon gas pressure, etc., the energy in the electron drift will have increased to such an extent that the collisions that occur between the electrons and gas molecules will be sufficiently violent to emit ultra-violet light radiations. This is the *radiation* or *resonance* potential for the given gas under the given conditions. The luminosity of the ultra-violet rays gives to the discharge the feature from which it derives its name of "glow discharge."

If the p.d. now be further increased, a value will be reached when ionization commences, and, as the p.d. continues to increase beyond this value, ionization of the path will proceed in geometrical progression until the path breaks down and a spark passes. Under suitable conditions the spark will become an arc and the p.d. will drop to a very much lower value, in consequence of the extreme ionization of the path, than that required for either resonance or ionization. Thus, a much higher voltage is required to maintain a glow discharge than is required for an arc. Therefore the glow discharge is preferable for a high cut-off value. Again, the characteristic of a discharge in open air is different from that of a discharge through a hole of fine bore. For small currents the two characteristics are identical, but as the current increases, the characteristic curves diverge. In Fig. 188 are given the curves for open air and capillary holes. The change in character is due to the increased rate of recombination of the ions in the discharge in the small capillaries; this recombination being aided by the presence of the "cold" walls. The effect of the walls is only appreciable with the larger currents. Hence the divergence of the two curves in Fig. 188. With increasing currents it is seen from these curves that there is a certain minimum voltage required to maintain a discharge through a given hole of capillary dimensions, which minimum depends on the actual size of the hole. At any voltage below this minimum the discharge cannot be maintained.

The elements of the Auto-Valve arrester are made of a

porous material, and the pores provide the capillary holes for the current discharge. Upon reference to Fig. 189 it will be seen that at a voltage A the current can increase to AB , but as the voltage is lowered the current will decrease until eventually it becomes C . If the voltage is then further slightly lowered and held constant at that point, the current ceases to flow. The value, therefore, falls to zero. The curve $ABCF$

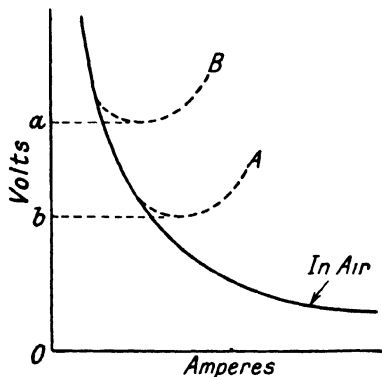

FIG. 188. DISCHARGES IN AIR AND THROUGH HOLES OF FINE BORE

The full line curve is for discharge through air. Curves A and B are for discharge through holes of fine bore— A being of greater diameter than B . oa represents minimum voltage for discharge through hole A . ob represents minimum voltage for discharge through hole B .

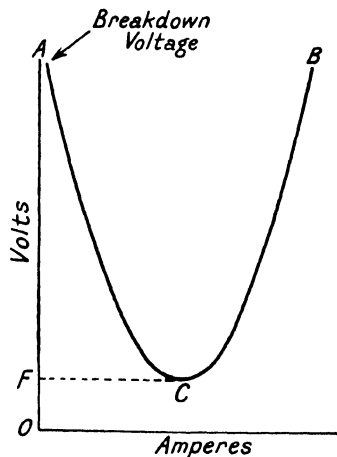

FIG. 189. THEORETICAL VA. CURVE FOR A POROUS DISC SUCH AS IS USED IN MODERN LIGHTNING ARRESTERS OF represents minimum voltage for maintenance of glow discharge through the disc.

which the current value follows is a typical volt-ampere curve for glow discharge through a hole of fine bore, and is the characteristic of the bore in question. In a piece of porous material the pores will be of different sizes, and each size will have its own particular breakdown and cut-off value. This means that the shape of the VA. curve for the material as a whole will be more irregular than that shown in the figure. An example curve of an Auto-Valve arrester is shown in Fig. 190.

If an amount of conducting matter be mixed with the material of the arrester elements, the characteristic will show a flattening of the top part of the curve. This is due to the conductivity of this material more than compensating for ion recombination in the bore discharge. If too much of this conducting matter be used, the bottom portion of the curve will be affected, and the

cut-off value for the elements will be very indefinite. Again, the grain size of the material must not be too coarse, or there will be a decided fall in the VA. curve. This is due to the pores running into one another and the resistance becoming reduced in value accordingly. Examples of curves for these conditions are given in Fig. 191.

The Thyrite Arrester. This arrester sets out to achieve, as

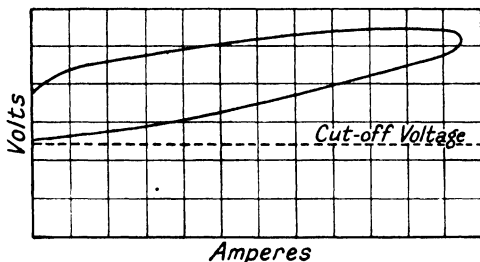

FIG. 190. ACTUAL VA. CURVE FOR A MODERN LIGHTING ARRESTER

nearly as is practically possible, the ideal of holding the voltage to the value it had upon the initial discharge. It therefore aspires to a horizontal volt-ampere characteristic such as is shown in Fig. 186. This characteristic gives the equation $RI = \text{Constant}$. The constant, of course, is the value of the critical voltage of discharge. The current curve from such an equation is a rectangular hyperbola, and, therefore, if the log values of R and I be plotted, a straight line graph will result. (See Fig. 192.) The slope of the curve is 45° , and, as $\tan 45^\circ = 1$, the slope of this ideal arrester is 1. In an equation of the form $RI^a = \text{Constant}$, the index a is always the slope of the curve when R and I are plotted on log-log paper. Thus, in the ideal case, $a = 1$. In the same equation R will always equal the constant, when I is unity, and this irrespective of the value of the index a . If then the constant and index are known, the characteristic of such an arrester will be known.

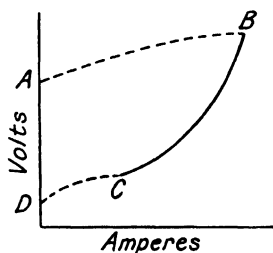

FIG. 191. SHOWING EFFECT OF DIFFERENT SIZES OF PORES ON THE VA. CHARACTERISTIC
Line *AB* represents the different breakdown values of the different sizes of pores.
Line *BC* represents current decreases in all pores.
Line *CD* represents the different cut-off values for the different sizes of pores.

The material for the discharge path of an arrester to this ideal should thus have an *RI* characteristic slope of unity when plotted on log-log paper. The sponsors of the Thyrite arrester also claim it as a desideratum that the material should not be affected by the steepness of the voltage wave, nor yet if the current is increasing or decreasing. It should have no loop in its VA. curve. They claim that Thyrite is a material that possesses the above qualities, with the exception that the index *a* has the value of 0.72 instead of unity. Thyrite takes its name from the Greek word meaning "gate" or "opening," and is a

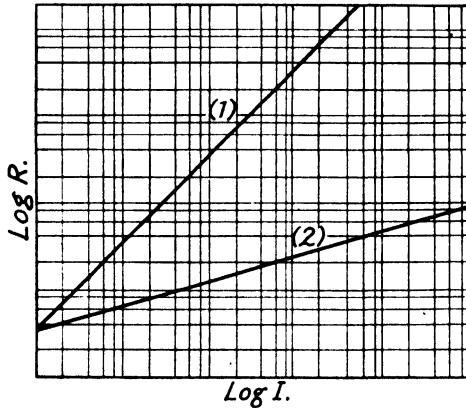

FIG. 192. VALUES OF *RI* = CONSTANT

Curve No. 1 is for equation $RI^1 = \text{Constant}$. Curve No. 2 is for equation $RI^a = \text{Constant}$ where *a* has value less than unity. The slope of Curve No. 1 is 45° and represents the characteristic for the "ideal" of this type of arrester. The slope of Curve No. 2 is $\tan B = a$.

material which has mechanical properties similar to those of dry-process porcelain. It is virtually an insulator at one voltage and a conductor at some higher voltage. The constant for Thyrite varies directly as the thickness of the material. That is, there is a constant voltage value for each thickness of element. The element used is 6 in. thick and has a constant equal to 400 approximately.

From the equation $RI^a = c$ (Constant) may be deduced, for the value $a = 0.72$, the relationship

$$R = cI^{-0.72}$$

whence

$$RI = cI^{0.28}$$

which equals the value of the voltage held by the discharge

of the arrester. Now the constant c has the value of 400 ohms approximately per kV. Therefore, for a 132 kV. system, the voltage of the transmitted wave, as determined by the arrester, is

$$400 \times 132 \times I^{0.28} = 52\,800 I^{0.28}.$$

If the breakdown value is 430 kV. the surge current of discharge will be

$$I^{0.28} = 430\,000/52\,800; \text{ or } I = 1\,778 \text{ amperes.}$$

Or, again, if a lightning stroke gave a surge current of 10 000 amperes the arrester voltage would be 570 kV., i.e. the voltage transmitted is not held constant because the index a is equal,

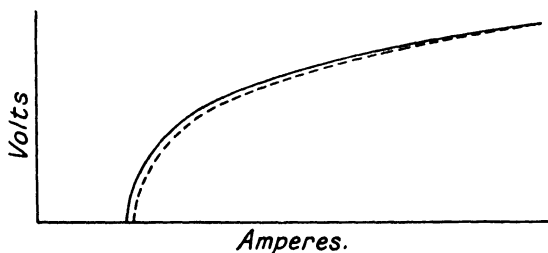

FIG. 193. EXAMPLE OF VA. CURVE FOR THE THYRITE LIGHTNING ARRESTER

not to unity, but to 0.72. A typical VA. curve for this arrester is given in Fig. 193.

The voltage of discharge for this arrester depends only upon the number of Thyrite elements in series between line and earth. The voltage drop across the arrester, or impedance voltage, depends upon the current discharged through the arrester; and this in turn depends upon the voltage of the surge on the line. The surge voltage to reach the arrester cannot be higher than the impulse flash-over of the line insulation. What has already been said about travelling waves will enable it to be understood that, according as the impedance of the arrester circuit is greater than, equal to, or less than the surge impedance of the line, so will the current through the arrester be less than, equal to, or greater than the current in the surge. The manufacturers of the Thyrite arrester have adopted the useful practice of plotting curves for the current and voltage for different arrester discharge circuit resistances, which curves they style *impulse regulation curves*,

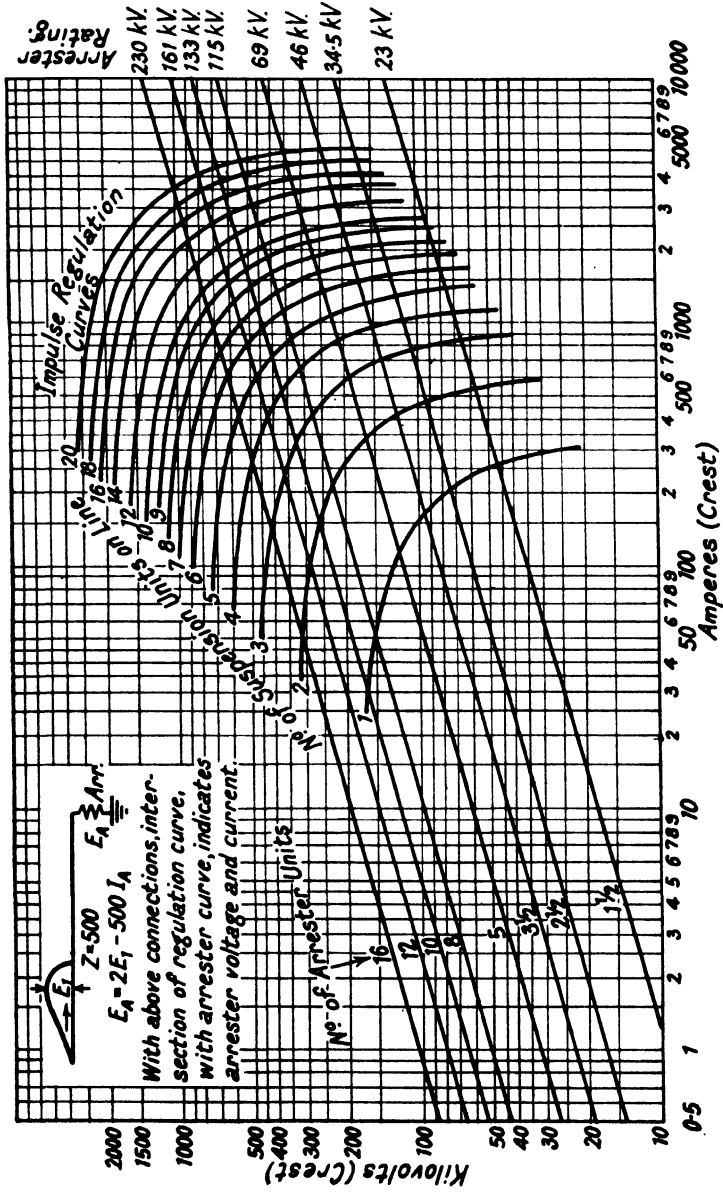

FIG. 194. PROTECTIVE PERFORMANCE OF THYRITE LIGHTNING ARRESTER FOR EARTHED NEUTRAL SERVICE
 Arrester located at end of line.

and combining them with the volt-ampere characteristic curves of the arrester. There is one such *impulse regulation* curve for each value of line insulation, and as the line insulation depends upon the number of insulator units per string on the line, these impulse regulation curves can be specified in terms of the number of such insulator units. An example of a set of curves for a grounded neutral system is shown in Fig. 194. The point of intersection of an impulse curve with a VA. curve represents the maximum voltage and current that can occur on a line that has insulation as represented by that impulse curve, and is fitted with an arrester of the stated VA. characteristics. Thus, in Fig. 194, consider the VA. curve for an arrester for 23 kV., and suppose this arrester is fitted to a line that has an

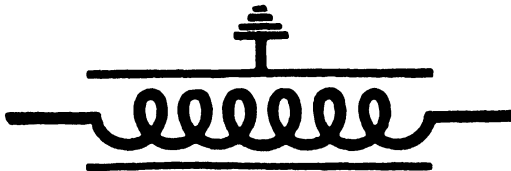

FIG. 195. DIAGRAMMATIC ARRANGEMENT OF FERRANTI SURGE ABSORBER
(Ferranti)

insulation of two units per string. The maximum surge voltage that can occur with this combination is, from the curve, 58 kV., and the maximum current, 540 amperes.

The Ferranti Surge Absorber. This device operates on a different principle from that of the Auto-Valve and Thyrite arresters. The two latter depend for their action upon the amplitude of the voltage surge, whereas the former is governed only by the steepness of the wave front. It is argued that the main purpose of a lightning protective device is to protect the plant, such as transformers, etc., rather than to prevent line flash-overs. Commercial economy will decide how much should be spent on lightning protective devices, and therefore the most suitable type of apparatus to install. Line flash-over is mainly a matter of surge amplitude, whereas damage to the windings of apparatus is undoubtedly effected by the steepness of the surge front as well as by the amplitude of the surge.

The Ferranti surge absorber is in effect a combination of inductance, resistance and capacitance, and is shown diagrammatically in Fig. 195. Now with such a combination it is

known from general principles that the greater the value of the capacitance and inductance, the longer will be the wave front of the transmitted wave, and the lower will be the amplitude of that wave. The effect of the resistance, however, is not so certain. It depends upon the relative values of the accompanying capacitance and inductance. The resistance at power frequency will be of smaller value than at surge frequency. For very small values of resistance, the amplitude of the transmitted wave may be greater than that of the initial wave. This is no doubt due to high frequency oscillations being superimposed on the transmitted wave.

In the surge absorbers under discussion, the values of inductance, capacitance and resistance are chosen to give a certain degree of protection. The absorber placed in series with the transmission line comprises an air core inductance, and adjacent to the conductors of the coil, but insulated from them, is a steel casing. This latter is called the *energy dissipator* and is connected to earth. The inductance coil is in effect the primary winding of a transformer; whilst the steel casing forms the secondary winding of one short-circuited turn. The losses due to the secondary current induced by the surge in the steel casing, represent the effectiveness of the absorber in reducing the amplitude of the surge. The device functions similarly to that of the combination of condensers and inductance coils as used in radio receiving set eliminators for smoothing out the rectified a.c. wave.

It is true that if the rate of increase of voltage is rapid enough transformer windings insulation will break down, although the actual voltage maximum may be comparatively low. The two first-named arresters will not take care of this condition, since they depend upon a given value of surge amplitude to cause operation, and are not affected by rate of increase of voltage. Indeed the Thyrite arrester makes a definite claim that the material of its discharge circuit is unaffected by steepness of wave front. The surge absorber is governed directly by the steepness of wave front. The steeper the wave front the more effective the absorber is in giving protection.

APPLICATION OF ARRESTERS

Whatever type of arrester be chosen, there are certain points in the application which may be considered with advantage. The degree of protection required will depend largely upon

the value of the apparatus connected to the line. Again, the effect of a surge of given value on an h.v. line will be less than the effect of the same surge on a line of lower voltage, because the ratio of the surge voltage to the high voltage will be less than the ratio of the surge voltage to the lower voltage. Line characteristics should be considered as well as those of the plant to be protected, and the device installed should be capable of preventing line flash-over for all but the most severe surges, as well as stopping the transmission of steep fronted waves.

Every case of lightning arrester installation should be considered on its own merits, and because of the somewhat intricate nature of the phenomena involved, it is preferable that the problem of the installation of lightning protective apparatus should be carefully considered.

One important consideration in regard to the installation of lightning arresters is that of the earth connection of the system. It is undoubtedly preferable from the point of view of arrester operation that the system should be earthed. When the system is insulated, there is always present the question of arcing grounds. Such arcing grounds are oscillatory discharges of high frequency, and the crest value may reach as much as three and a half times the normal system maximum. An arcing ground may endure for quite an appreciable time, in which case a considerable current will discharge through an arrester. Unfortunately there is no arrester with a large enough thermal capacity to handle a discharge of this nature, and consequently an arrester so stressed will fail. As already mentioned, an average lightning discharge may be of the order of 2×10^3 joules, whereas an arcing ground can be of much greater energy.

When an insulated system has to be equipped with lightning arresters there are one or two courses open. One is to install arresters of a rating suitable to the phase voltage of the system and thus secure the best protection against lightning at the expense of possible arrester failure due to arcing grounds. The second is to install arresters of a higher rating; which will not be subject to the same failure from arcing grounds, but will also not give so fine a protection against lightning surges. Under such conditions a compromise is unavoidable, since the two demands on the arrester are fundamentally opposed.

Interference. It is possible for high voltage and low voltage lines to run adjacent. In this case the effect of the low voltage line on the high voltage line is negligible, under both healthy and fault conditions. Also, under healthy conditions, the effect of the high voltage lines on the low voltage lines is negligible, because the electrostatic and electro-magnetic fields are more or less balanced. But under fault conditions, the effect of the high voltage lines on the low voltage lines may be considerable. Again, the effect of an arcing ground on a h.v. line will induce a similar trouble on the l.v. line. Thus it is possible

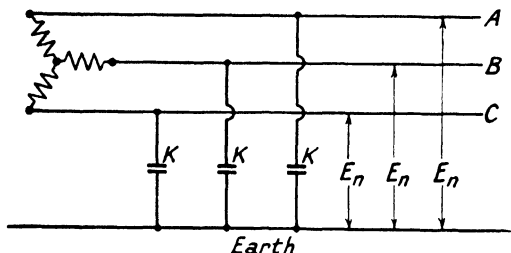

FIG. 196. CAPACITANCE AND VOLTAGE DISTRIBUTION OF A THREE-PHASE SYSTEM WITH NEUTRAL INSULATED AND UNDER HEALTHY CONDITIONS

for a disturbance on a h.v. line to cause the arrester on an adjacent l.v. line to discharge.

To calculate the effect of interference between two sets of lines, say *A* and *B*, it is necessary to know the value of dV/dt for the lines *A* on which the initial surge occurs, and also to know the value of the mutual inductance between the two sets of lines. Then, if dv/dt represents the value of the surge induced on lines *B* by the surge dV/dt on lines *A*,

$$dv/dt = M (dV/dt). \quad \dots \dots \dots (109)$$

$$M = 2l \{ (\log_e 2l/a) - q \} 10^{-4} \text{ henries per kilometre.}$$

l = length of line in metres, *a* = separation of two lines in metres. *q* ∝ 0.5 and 5.0 depending on length of line.

Arcing Ground Suppressors. The danger of over-voltages on the lines caused by arcing grounds, leads naturally to the question of the arcing ground suppressor. Arcing grounds cannot occur on an earthed system unless the line be of considerable length, or be earthed through a reactance. Also, arcing grounds do not occur on lines of short length whether

the system be earthed or insulated, because of the negligible capacity currents of such lines.

Fig. 196 shows diagrammatically a three-phase transmission line connected to the high voltage winding of a power transformer. Each of these lines has a capacitance to earth, which is given by the equation

$$C = \frac{3.89 l}{100 \log_{10} (24h/r)} \mu\text{F.} \quad (110)$$

where l is length of line in miles; h is height of conductor from earth in feet, and r is radius of conductor in inches.

The capacitance current to earth is given by

$$I_e = 2\pi fcE_n \quad (111)$$

E_n is the pressure to earth under healthy conditions. E_n is the same for all phases, and so also is the charging current when the lines are symmetrical to earth. Therefore

$$I_A = I_B = I_C$$

Should an earth occur on any one of these lines, say line A , the pressure of the other two lines immediately increases to $(\sqrt{3})E_n$. As a consequence, the capacitance current in these lines will increase likewise to $(\sqrt{3})I_B$ and $(\sqrt{3})I_C$. For line A , E_n obviously equals zero, and also $I_A = 0$.

When a flash-over occurs on an insulated neutral system, the current which flows is the capacitance current that charges the line. Power current cannot flow since there is no return path. If the line is quite short, the capacitance current is very small, and the effect of arcing grounds is negligible. But for lines of greater length, the capacitance current becomes more and more important. On h.v. networks of large capacity, the effect of arcing grounds is of considerable moment. If the lines are symmetrically spaced to earth, the charging currents are equal, and, in a three-phase system, their sum at any instant is zero. Thus: $I_A + I_B + I_C = 0$.

Consider a three-phase 132 000 volt line with symmetrical spacing to earth, and suppose that these have, under healthy conditions, a capacitance current of 50 amperes per phase. When an earth fault occurs on any phase, say phase A , the capacitance current distribution changes. The voltage of phase A drops to zero, and the capacitance current drops to zero also. The voltage of phases B and C each becomes 132 000

322 OUTDOOR HIGH VOLTAGE SWITCHGEAR

volts, and the capacitance current $\sqrt{3} \times 50 = 86.5$ amperes. The earth fault current in phase *A* is therefore the vectorial sum of the capacitance currents in phases *B* and *C*, i.e. equals $\sqrt{3} \times 86.5$ or 150 amperes. (See Fig. 197.)

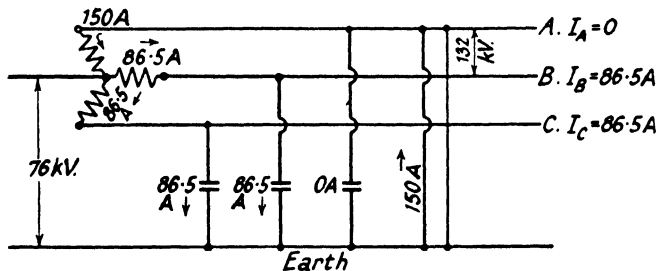

FIG. 197. DISTRIBUTION OF CURRENTS WITH AN EARTH ON THE *A* PHASE

The accompanying transient voltage will be approximately 3.5 times the normal line voltage.

Prof. W. Petersen instituted the use of an inductance coil between the neutral point and earth in order to prevent the maintenance of an arcing ground. The value of the reactance of this coil must be a certain function of the capacitance of

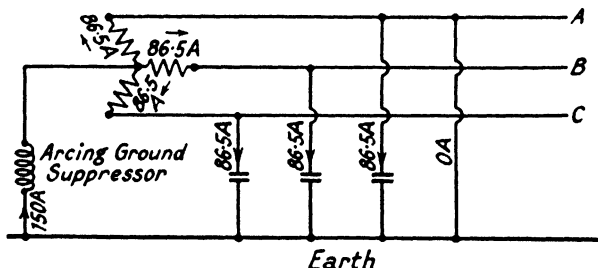

FIG. 198. DISTRIBUTION OF CURRENTS WITH AN EARTH FAULT ON THE *A* PHASE AND AN ARCING SUPPRESSOR FITTED

the lines to be protected. Whatever current flows through the reactance of this coil will be in lagging quadrature with the voltage; and, as earth fault currents are in leading quadrature with the voltage, it is clear that if these two currents can be made numerically equal, they will cancel out. Fig. 198 gives the diagram for the current distribution for the above example when a Petersen coil is connected between neutral and

earth. The coil must be such that when phase voltage is impressed across it, it will pass three times the normal charging current of any one conductor of the line.

The effect of the application of the arc suppression coil can perhaps be best understood by consideration of the method of phase sequence vectors. Let E_R, E_Y, E_B in Fig. 199, be the voltage, and I_R, I_Y, I_B , be the line charging current vectors of a healthy system. These charging or capacitance current vectors will lead the voltage vectors by 90° . Let C be the capacitance of any line to earth, and E_ϕ be the phase voltage. Then the line-to-earth charging current is given by $I_R = I_Y = I_B = \omega C E_\phi$; where $\omega = 2\pi f$. The voltage vectors will be designated by—

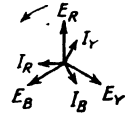

FIG. 199
LINE CHARGING CURRENT AND VOLTAGE VECTORS FOR A HEALTHY SYSTEM

$$\left. \begin{array}{l} \begin{array}{c} \text{+j} \\ \swarrow R \\ \uparrow \\ \searrow Y \\ \swarrow B \\ \text{-j} \end{array} \\ \begin{array}{l} -1 \\ +1 \end{array} \end{array} \right\} \begin{array}{l} E_R = jE_\phi \\ E_Y = (\frac{1}{2}\sqrt{3} - j\frac{1}{2})E_\phi \\ E_B = (-\frac{1}{2}\sqrt{3} - j\frac{1}{2})E_\phi \end{array} \quad (112)$$

From which the sequence vectors are

$$\left. \begin{array}{l} \text{Phase Sequence Vectors} \\ \begin{array}{c} \text{+ve} \\ \swarrow R \\ \uparrow \\ \searrow Y \\ \swarrow B \end{array} \quad \begin{array}{c} \text{-ve} \\ \circ \end{array} \quad \begin{array}{c} \text{Zero} \\ \circ \end{array} \\ \begin{array}{l} E_R^+ = jE_\phi; E_Y^+ = \lambda^2 E_R^+; E_B^+ = \lambda E_R^+ \\ E_R^- = 0 \text{ etc.} \\ E_R^0 = 0 \text{ etc.} \end{array} \end{array} \right\} (113)$$

The current vectors are

$$\left. \begin{array}{l} \begin{array}{c} \swarrow Y \\ \uparrow \\ \searrow B \\ \swarrow R \end{array} \\ \begin{array}{l} I_R = (-1)I_\phi \\ I_Y = (\frac{1}{2} + j\frac{1}{2}\sqrt{3})I_\phi \\ I_B = (\frac{1}{2} - j\frac{1}{2}\sqrt{3})I_\phi \end{array} \end{array} \right\} (114)$$

From which

$$\left. \begin{array}{l} \text{Phase Sequence Vectors} \\ \begin{array}{c} \text{+ve} \\ \swarrow Y \\ \uparrow \\ \searrow B \\ \swarrow R \end{array} \quad \begin{array}{c} \text{-ve} \\ \circ \end{array} \quad \begin{array}{c} \text{Zero} \\ \circ \end{array} \\ \begin{array}{l} I_R^+ = (-1)I_\phi \text{ etc.} \\ I_R^- = 0 \text{ etc.} \\ I_R^0 = 0 \text{ etc.} \end{array} \end{array} \right\} (115)$$

Now consider an earth fault on the line of the yellow phase, and on a neutral insulated system not protected by an arc

suppression coil. The system of vectors now becomes as shown below. From this it will be seen that the vector designations are

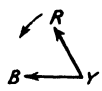

$$\left. \begin{aligned} E'_R &= (-\frac{1}{2}\sqrt{3} + j\frac{3}{2})E_\phi \\ E'_Y &= 0 \\ E'_B &= (-\sqrt{3})E_\phi \end{aligned} \right\} \dots \dots \dots (116)$$

which gives

Phase Sequence Vectors

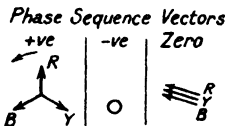

$$\left. \begin{aligned} E'_R^+ &= jE_\phi \text{ etc.} \\ E'_R^- &= 0 \text{ etc.} \\ E'_R^0 &= (-\frac{1}{2}\sqrt{3} + j\frac{1}{2})E_\phi \end{aligned} \right\} \dots \dots (117)$$

And the current vectors



$$\left. \begin{aligned} I'_R &= (-\frac{3}{2} - j\frac{1}{2}\sqrt{3})I_\phi \\ I'_Y &= (\frac{3}{2} + j\frac{3}{2}\sqrt{3})I_\phi \\ I'_B &= (-j\sqrt{3})I_\phi \end{aligned} \right\} \dots \dots \dots (118)$$

Whence

Phase Sequence Vectors

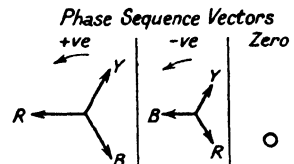

$$\left. \begin{aligned} I'_R^+ &= (-2) \text{ etc.} \\ I'_R^- &= (2 - j\frac{1}{2}\sqrt{3}) \text{ etc.} \\ I'_R^0 &= 0 \end{aligned} \right\} \dots (119)$$

The inductance of the arc suppression coil is chosen to correspond to the capacitance to ground of the network. Thus

$$1/\omega L = 3\omega C \dots \dots \dots (120)$$

where $\omega = 2\pi f$.

This condition will give, for an earth fault, a current in the arc suppression coil equal to in magnitude, but 180° displaced from, the current in the earth fault. Therefore the vectors for a fault on the yellow phase, as in the above example, but with a suppressor coil inserted, become

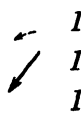

$$\left. \begin{aligned} I'_R &= 0. \\ I'_Y &= (-\frac{3}{2} - j\frac{1}{2}\sqrt{3})I_\phi \\ I'_B &= 0 \end{aligned} \right\} \dots \dots \dots (121)$$

which resolve into components, thus

Phase Sequence Vectors

$$\left. \begin{aligned}
 I_R^{+} &= (+1) I_\phi \text{ etc.} \\
 I_R^{-} &= \left(-\frac{1}{2} + j\frac{1}{2}\sqrt{3}\right) I_\phi \text{ etc.} \\
 I_R^{0} &= \left(-\frac{1}{2} - j\frac{1}{2}\sqrt{3}\right) I_\phi \text{ etc.}
 \end{aligned} \right\} \quad (122,$$

From the above it is to be observed that the insertion of an arcing ground suppressor coil in the neutral results, on the occasion of an earth fault, in the establishment of the following—

- (1) A positive sequence current the same as that for healthy conditions.
- (2) A negative sequence current the same as that for healthy conditions, i.e. 0.
- (3) A zero sequence current, as the result of the displacement of the neutral voltage to earth.

The result (1) is obtained from the fact that the sum of the current vector for the fault without suppressor coil and the current vector for the fault with the suppressor coil is equal to the current vector for the healthy condition. Thus—

	I_R^{+}	from equation equals	-2
	I_R^{+}	„ „ „	$+1$
Sum equals	<u>I_R^{+}</u>	„ „ „	<u>-1</u>

The result (2) is obtained in a similar manner, thus

	I_R^{-}	from equation equals	$\frac{1}{2} - j\frac{1}{2}\sqrt{3}$
	I_R^{-}	„ „ „	$-\frac{1}{2} + j\frac{1}{2}\sqrt{3}$
Sum equals	<u>I_R^{-}</u>	„ „ „	<u>0</u>

Thus it is seen that the insertion of the coil in the neutral has brought the system back to normal, with the exception of the zero sequence currents through the coil. These currents are equal and opposite to the fault current that would otherwise flow from the earthed phase.

In construction, the arcing ground suppressor is somewhat similar to a small power transformer. The inductance coil is wound on a laminated core and immersed in oil in a

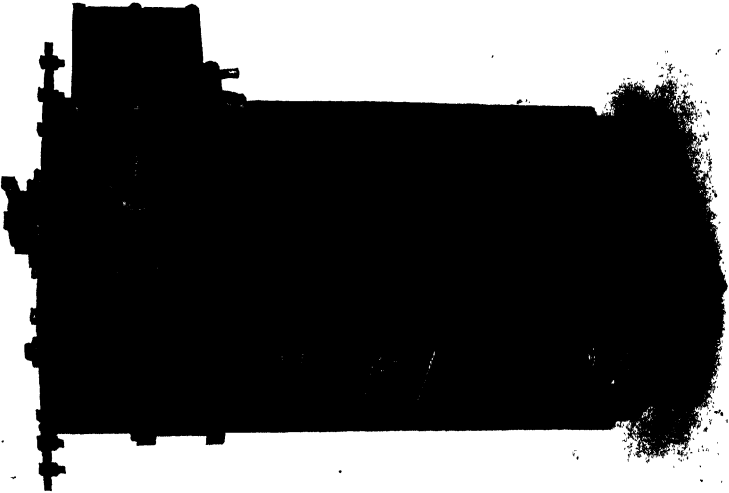
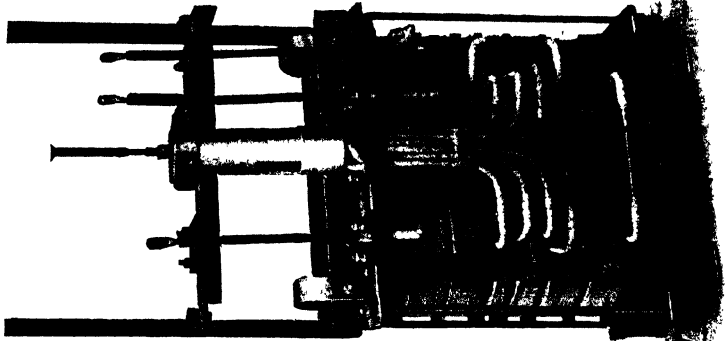

Fig. 200

suitable tank. An oil cooling system is incorporated, and also an oil conservator. The high voltage lead-in bushing can be of the same design as that used for the transformers or oil circuit-breakers. The rating of the suppressor winding will be governed by the network on which it is to be used, and obviously the same general laws for copper losses and iron losses, etc., that apply to transformer windings will apply to the winding of the arc suppressor.

From what has been given above, it will be understood that the arc suppressor compensates the earth capacitance current of the network. When a portion of the network is cut off as a result of some switching operation, the network charging current will be altered. To compensate for this change, it is necessary to have some adjustment provided on the arc suppressor. This adjustment is provided by taps taken from the suppressor winding. These tapped connections are taken to a selector switch which is suitably marked. Thus a range of settings is provided to accommodate the variations likely to occur on the network. In general, however, a well-designed arc suppressor will operate quite satisfactorily on a given setting for deviations in capacity up to a maximum of about $7\frac{1}{2}$ per cent. An illustration of the arc suppressor is given in Fig. 200.

Actually, there is a small energy component in the earth circuit due to losses in the line, and to copper and iron losses in the suppressor coil. This energy component will affect the relationship between the line capacity and coil inductance current, but the effect is sufficiently small to be ignored in practice.

It is worthy of note that the installation on a system of an arcing ground suppressor coil can reduce by about 80 per cent the number of times oil circuit-breakers will trip out on earth faults. An interesting application of arcing ground suppressors is made on a 66 000 volt system in Malaya. Here, the suppressor coil is used in conjunction with an earthing resistance; see Fig. 201. A tapping is made on the suppressor coil (1) to give a pressure of approximately 400 volts. This supply is connected to the primary of a small voltage transformer (2), which latter passes on the supply at about 110 volts to a relay (3) with inverse time characteristics. The contacts of this relay control an auxiliary supply to the operating coil of a contactor (4), and the latter, when closed, puts the same supply on to the closing coil (5) of an oil circuit-breaker (6). The oil circuit-breaker in turn brings the earthing resistance (7) in circuit in

parallel with the suppressor coil. By this means the current from a persistent earth fault is limited to a definite value by the resistance, and in due time the fault is cleared by the earth fault protective gear installed on the same system.

It may be imagined that the combination of line capacitance and coil inductance will tend to create over-voltage surges due to resonance. This is prevented by transposing the lines as frequently as possible to maintain the neutral point at earth

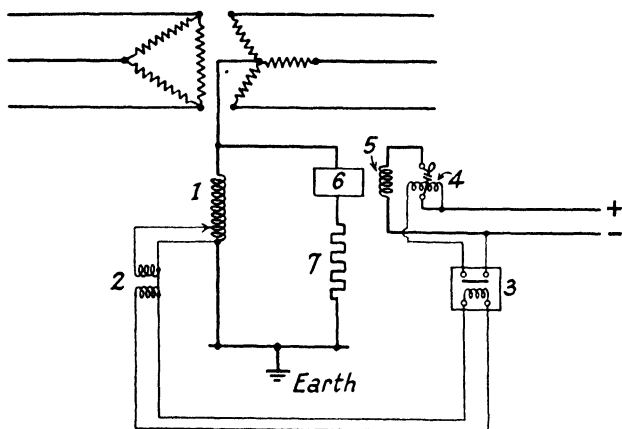

FIG. 201. ARCING EARTH SUPPRESSOR USED IN CONJUNCTION WITH EARTHING RESISTANCE

- | | |
|------------------------------------|---------------------------------------|
| 1 = Arcing earth suppressor coil. | 5 = Oil circuit-breaker closing coil. |
| 2 = Voltage transformer 400/110 V. | 6 = Oil circuit-breaker. |
| 3 = Inverse time relay. | 7 = Earthing resistance. |
| 4 = Contactor closing coil. | |

potential, and by arranging the iron circuit of the suppressor coil so that magnetic saturation is obtained under the working conditions. This last tends to limit the number of tappings that can be made to a coil and therefore reduce its flexibility. The Metropolitan-Vickers Co. have a patented type of coil on which a range of tappings is provided that will give a 4 to 1 range of adjustment.

On a large network it is preferable to install an arc-suppressor coil at different points of the systems. This will enable smaller coils to be used, since the total current rating of all the coils installed must equal the capacitance current of the total network. The advantage of this is that the individual coil currents are distributed through the various transformers

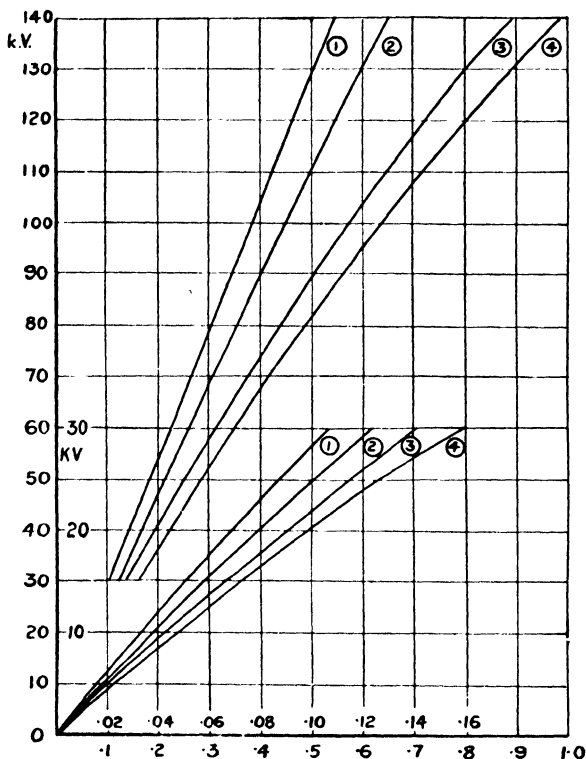

FIG. 202. AVERAGE VALUE OF EARTH CURRENTS FOR OVERHEAD TRANSMISSION LINES

CURRENT TO EARTH IN AMPERES PER MILE

- (1) For a single line without earth wire
- (2) For a single line with earth wire
- (3) For a double line without earth wire
- (4) For a double line with earth wire

on the system, and there is therefore not the same likelihood of overloading the windings of one transformer should an earth fault occur when the normal load current is high. This possible overloading of transformer windings due to the use of arc-suppressor coils is a point that requires careful consideration. Practice at present suggests that the arc-suppressor coil should have a rating of about 25 per cent of that of the transformer. If the network capacitance current is too large for this, then two or more arc-suppressor coils must be required. In Fig. 202

curves are given to indicate the average value of earth current for overhead transmission lines at various voltages, when one phase is earthed and the neutral point insulated. These curves will provide a guide to the capacitance of an arc-suppressor coil necessary for a given network.

CHOKE COILS

The question of the insertion of choke coils in overhead transmission lines has received quite an amount of attention in recent years, and the general outcome of the investigations made seems to indicate that such coils serve no useful purpose unless they are of a size that is really not a practicable proposition.

It must be admitted that a choke coil, whatever its size, represents in effect an obstruction in the path of a traveling wave. From what has been given in the first part of this chapter, it will be understood that when a wave reaches a point of discontinuity in the line, such as would be provided by a choke coil, reflected and transmitted waves will result. The proportion of the reflected wave to the transmitted wave will depend solely on the relative values of the surge impedances involved, and upon the shape of the incoming wave.

It is definite that the more steep the wave, either in front or tail, the more active becomes the choke coil in its influence upon the wave form. The matter therefore is entirely one of relative proportions. It has been found by test and experiment that the effect of small choke coils, say of the order of $40 \mu\text{H.}$, is quite inappreciable except on waves with rectangular fronts. Such steep fronted waves do not occur in practice, and the effect on a lightning wave of 7 or 8 μ sec. front by a choke coil of $40 \mu\text{H.}$ inductance would not be sufficient to alter the wave shape to any extent.

When an incoming wave crosses the end of a choke coil, there is a rate of change of current through that end of the coil proportional to the slope of the front of the wave, and in consequence an e.m.f. is induced proportional to this rate of change of current. This is in the nature of a back e.m.f., and is superimposed on that of the incoming wave. It is what has previously been referred to as the reflected wave, and the equation $E_r = E_o + E_a$ here holds good in so far that the

actual voltage at any instant on the incoming end of the choke coil is equal to the sum of the incoming surge voltage at that instant and the voltage of the reflected wave at the same instant.

The voltage at the other end of the coil is controlled by the fact that it has as suddenly impressed upon it, but through the choke coil, a voltage equal to that at the incoming end, and this is what has been termed the transmitted wave. There are two effects, however, which tend to make the shape of this

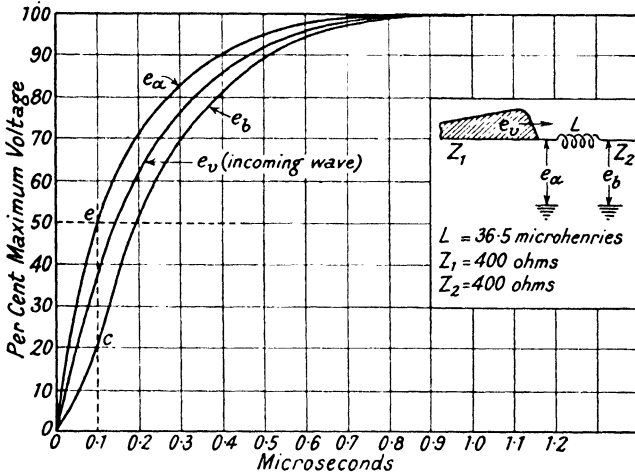

FIG. 203. EFFECT OF A CHOKE COIL ON AN INCOMING WAVE OF ONE MICROSECOND FRONT

- e_a = Voltage at incoming end of choke coil
- e_b = Voltage at outgoing end of choke coil
- e_v = Incoming wave voltage
- e and c = voltage values at 0.1μ sec.

transmitted wave different from that of the incoming wave. One is that an amount of energy is absorbed from the wave as it passes through the coil; and the other is the fact that the wave, when at the outgoing end, Fig. 203, passes from a relatively high surge impedance to a lower one. Equation (101) shows that this will result in a drop in the pressure value of the transmitted wave. Hence, the voltage passed on to the apparatus beyond the choke coil is theoretically less than the voltage in the coil.

In Fig. 203 is shown the effect of a choke coil of $36.5 \mu\text{H}$. which is an average size coil, on a wave of 1μ sec. front. In this it will be observed that there is no decrease in ultimate peak value, but the front of the transmitted wave is slightly flatter

than that of the incoming wave, whilst the front of the reflected wave is steeper. No appreciable decrease in the amplitude of an incoming wave can occur unless the choke coil has impedance big enough to absorb sufficient energy to so effect it. The greatest factor leading to that end is the capacitance of the coil, and for this to be effective a very big coil is required.

The flattening of the transmitted wave shown in the figure is an advantage, however small it may be, since even a slight flattening of a steep-fronted wave represents quite an appreciable reduction in the rate of change of current in the end turns of a transformer winding.

The increase in voltage on the line side of the choke coil by the reflected wave is an advantage when a lightning arrester is connected to this side of the coil. Thus, suppose the discharge gap of the arrester were set to spark over at 50 per cent of the peak value of the surge, then this value would be reached a fraction of a second earlier by the reflected wave than it would by the incoming wave were no coil present. The arrester would therefore commence to function so much earlier. The actual gain is too small to be of use in the example shown in the figure, since the advantage in time is only 0.05μ sec., and this for a 1μ sec. fronted wave. The corresponding gain in time with the same coil and a lightning surge of, say, 7μ sec. front would be less still and therefore quite negligible in practice, because the time-lag of an average lightning arrester discharge gap is of the order of 0.1μ sec.

A disadvantage of the choke coil is the possibility of dangerously high voltages being reached by the crossing of the waves that will be reflected backwards and forwards between the inductance of the choke coil and that of the windings of the protected apparatus. Furthermore, the rate and manner at which the voltage builds up on the transmitting side of the coil depends upon the relative values of resistance and inductance, etc. It may be that the peak value will be reached in the form of an aperiodic, or it may be oscillatory. If the conditions are such that the latter occurs, then a peak value is reached that is probably twice as great as that of the normal maximum of the wave. This condition is, of course, synonymous with resonance of the coil, and represents the worst feature the choke coil has from the point of view of transmission line use.

CO-ORDINATION OF INSULATION AND CO-ORDINATING GAPS

On many systems of the outdoor type it is the custom to have a "weak link" in the insulation chain. The intention of this is that, in the event of travelling waves occurring on the system from various causes, spark-over will take place at this weak link and the wave will be prevented from reaching the station apparatus. Such a weak link is sometimes obtained by varying the number of units in the strings of line insulators, so that, from about half a mile out of the station, the number of units per string becomes less on approach to the station. Grading in this manner is obviously limited to two or three units per string, even on very high voltage systems. On systems of about 66 kV. it is limited to one unit, and even this gives a coarse grading. An improvement on this method is to fit arc horns to the various insulator strings, and to set the gaps of these to give the required spark-over value. A drawback of the "half mile of weak insulation" scheme is that search has to be made over the whole of this length of line for the damaged insulator, if puncture should result from the impulse. It must not be forgotten that, even when horns are fitted to a post or string of insulators, there is a very good chance of the porcelain cracking from the heat of the spark cascade which can occur through the wind blowing the arc on to the surface of the porcelain.

The idea of grading is sometimes taken further, and the different sections of the equipment are arranged to have different insulation values. Thus, the transformers proper would have the highest insulation value, the transformer and circuit-breaker bushings the next, whilst post and isolating switch insulators, and line insulators would probably come next. This is the idea of co-ordinating the values of the insulation of the different pieces of apparatus on the system, so that the most expensive part of the equipment is rendered the most proof against damage, whilst the other parts are less so.

Another method of protection on the "weak link" principle is to install a spark gap on the line, so that when spark-over occurs the charge is carried through the gap direct to earth. The setting of this gap is such that its dielectric strength will be co-ordinately lower than that of the apparatus it is to protect; and from this feature it is known as a *co-ordinating gap*.

Before the merits of either of these methods can be considered

it is necessary to give some attention to the properties of the insulation involved. For instance, it is known that insulation of any kind has not a single breakdown value, but several dependent on the nature of the electrical stress. Whilst we know that there may be a voltage value which a given piece of insulation will withstand indefinitely, it is also known that the same piece of insulation will stand up to much higher voltages for certain given periods of time, and in general, the higher the applied voltage, the shorter the time period for which the insulation will withstand it without deterioration. Therefore, before any real co-ordination can be obtained between parts of a system, it is necessary to know the characteristics of the insulation and also those of the voltage waves that are to be encountered.

Now apart from oil and bushing insulators, the system is made up of insulation in the form of porcelains for the lines, bus-bars, etc., and fibrous insulation in the form of barriers for transformer windings, etc. In the first case, failure mostly takes the form of surface flash-over; whilst in the second, failure is more generally by puncture of the insulation. Oil is a self-sealing insulator, whilst bushing insulators are designed to spark over before puncture. Extensive tests are being conducted to determine the volt/time characteristics of the fibrous type of insulation, since the apparatus using this is that which first and foremost has to be protected against damage from impulse waves. The impulse spark-over characteristics of porcelain insulators have been studied by Allibone, Hawley and Perry, and a very valuable contribution to the science of impulse testing and surge phenomena is given in their paper "Cathode Ray Oscillographic Studies of Surge Phenomena."

In Fig. 204 is given a characteristic curve for a transformer insulation barrier, and it will be noticed that the percentage increase in voltage strength is rapid with time values below one microsecond.

It is found that a spark gap formed with electrodes of square section of about $\frac{5}{8}$ in. side gives a volt/time characteristic somewhat similar to that of the barrier insulation, and to that of post and strain insulators. Such a gap, known as a *rod gap*, might be set so that its characteristic curve would be just below that of the insulation to be protected.

It has already been stated that the shapes of lightning waves vary considerably from the very steep fronted waves that

follow a direct hit, to the more sloping ones from side strokes. If the curve for insulation shown in Fig. 204 be taken as representative of such insulation in general, then it will be seen that for time values less than one microsecond the insulation curve is not so steep as the rod gap curve. To set the rod gap so that its curve would lie wholly without the insulation curve would mean that, for values greater than one microsecond, the discrepancies between the breakdown values of the gap and insulation would be too big. This is one of the weaknesses of the rod gap as a means of protection. Another weakness is

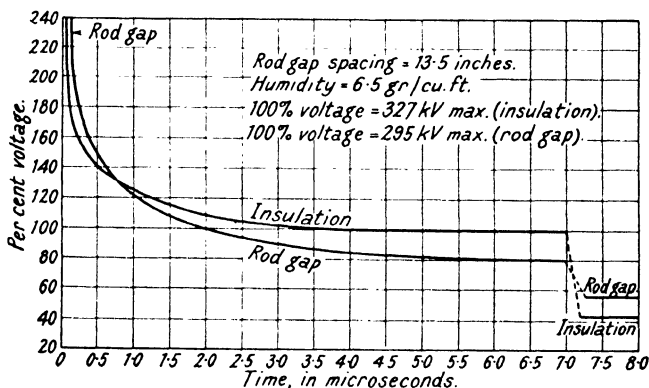

FIG. 204. RELATIVE IMPULSE STRENGTHS (VOLT-TIME CURVES) OF AN INSULATION BARRIER AND A ROD GAP. 1.5/40 POSITIVE WAVE
(From a paper, by Montsinger, Lloyd and Clem. "A.I.E.E. Journal")

that when it does discharge, the apparatus is safeguarded at the expense of putting a direct earth on the line involved.

It may be thought that the first weakness could be overcome by substituting a sphere gap for the rod gap, since the time-lag of the former is practically nil. Or, it has been suggested that a sphere gap be used in parallel with the rod gap. The big drawback to both of these schemes is that the sphere gap loses its particular property if its surface suffers the least deformation. Therefore, were such a gap to spark over under a lightning surge and then be subjected to the power arc that follows, the burning on the surfaces of the spheres would alter the characteristic of the gap and make it more akin to that of a point gap. This is a much more serious drawback to the use of a sphere gap for this purpose than is the distortion to the gap surface caused by dirt or corrosion, since the latter could be overcome

by suitable shielding. The rod gap thus becomes one of the most practical means of protection of apparatus against voltage surges, and if applied correctly can be made to give quite a reasonable measure of protection within the limits of its capabilities. It must, however, be realized that the function of the rod gap is to save the apparatus at the expense of shutting down the line, because it is certain that the earth current which would follow the discharge of the gap would operate the protective gear to open the associated circuit-breaker.

The voltage surges that occur on a system are of two kinds; those which result from switching operations and from arcing grounds, and those which are of lightning origin. In general, the higher the voltage of the surge, the steeper the front. On the other hand, statistics indicate that the crest values of less than 5 per cent of switching surges reach four times normal voltage. This means that if the normal frequency spark-over voltage of the insulation is a little more than four times that of the system line-to-neutral voltage, there is very little likelihood of breakdown from switching surges. Almost the same values apply in the case of surges from arcing grounds. Therefore there seems no point in making further insulation co-ordination for this purpose. It is when we come to the disturbances from lightning causes that co-ordination is required. There is, however, no logical reason why the insulation within a station should have different values. One value should be adopted for this in accordance with the purposes for which it is required, and the rod gap should be set to spark over at some lesser value. In order to prevent trouble due to voltage reflections from the transformer, the gap should be placed as far from the former as possible. It is unfortunate that the gap will not relieve the transformer from the repeated stresses just below spark-over value that may sometimes occur. The best cure for this is to use a lightning arrester in conjunction with the gap. The arrester can be chosen to deal with surges induced by side strokes of lightning, whilst the co-ordinating gap can be set to operate on very severe surges of the order of direct hits. The function of the arrester will be to absorb the energy of the surge without closing down the line, and that of the gap will be to save the apparatus in the extreme cases, even at the expense of the line supply.

In an endeavour to obtain proper co-ordination, it is becoming the practice to state that apparatus should be designed so

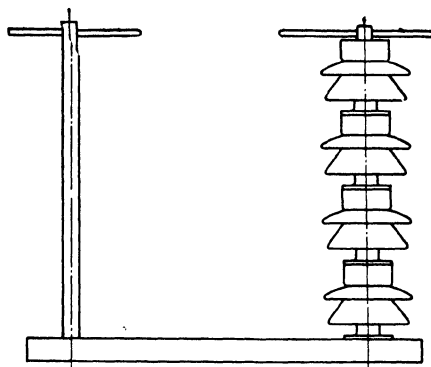

FIG. 205. TYPICAL CO-ORDINATING ROD-GAP

TABLE XVIII

SPARKOVER CHARACTERISTICS OF ROD GAPS

Barometer, 760 mm.; Temperature, 25° C.; Humidity, 6.5 grains per cub. ft.; Vapour Pressure, 0.6085 in. of Hg.

Gap Spacing, In.	Flash-over kV. (to nearest 5 kV. above 150)		
	60-cycle Crest, Dry	Minimum Positive Impulse Waves	
		1/5 μ sec.	1.5/40 μ sec.
0.5	—	24	24
1.0	—	42	42
1.5	—	53	53
2.0	42	61	61
2.5	—	67	67
3.0	—	75	74
3.5	—	85	82
4.0	78	95	89
4.5	—	107	98
5.0	84	120	106
6.0	103	148	124
8.0	119	195	160
10.0	145	240	190
15	215	—	—
20	275	440	350
25	345	—	—
30	415	640	505
35	485	—	—
40	550	835	650
45	620	—	—
50	685	1 035	800
55	755	—	—
60	820	1 230	945
65	890	—	—
70	955	1 425	1 095
75	1 010	—	—
80	1 080	1 620	1 240
85	1 130	—	—
90	1 190	1 815	1 385
100	1 315	2 010	1 530

that impulse strength against lightning is greater than the impulse spark-over voltage to earth of an air rod gap, similar to that shown in Fig. 205.

This means that the transformer will have an insulation, the impulse strength of which has been measured on a rod gap. Therefore, if a similar rod gap, but with a slightly smaller setting, be connected to the line close to the transformer, it is impossible for impulse waves above a given value, coming from the line, to reach the transformer. The insulation value of the line equipment then becomes independent of that of the station equipment, and variation of line insulation can be made to suit local conditions. Unfortunately, the above does not hold for direct lightning strokes of very steep front, because, as already indicated, the rod gap is not quick enough on such steep fronted waves. For this last case there seems only one solution, which is to combine station shielding by a network of overhead earth wires and counterpoises, with rod gaps and lightning arresters. The arresters would clear the system of impulses up to a certain steepness without further disturbance, whilst the earth wires would tend to slope back the front of an extremely steep incoming wave, and thus give the rod gap a chance to discharge within the necessary time interval. The probability of direct hits on the station lines would be proportionally reduced by the amount of shielding provided.

An advantage of the use of the rod gap is that when spark-over does occur, the arc is away from the porcelain insulators, and therefore the troubles due to cracked porcelains and the difficulty of locating them are entirely removed. An amount of research work has yet to be done before definite values can be given, and unfortunately many words have yet to be spoken before agreement is reached by the authorities concerned on the conventions to be adopted as the basis of measurements.

A further difficulty in the use of rod gaps for co-ordinating purposes is the effect that weather has on the spark-over value for a given setting. Such a gap is definitely affected by weather conditions, whilst transformer insulation under oil, with which the gap is to co-ordinate, is not so affected. These conditions may be divided into three parts—

- (1) Humidity.
- (2) Relative air density.
- (3) Rainfall.

Many authorities in America have studied this question, and the general findings would seem to follow the argument given below.

Humidity. The average increase on minimum spark-over

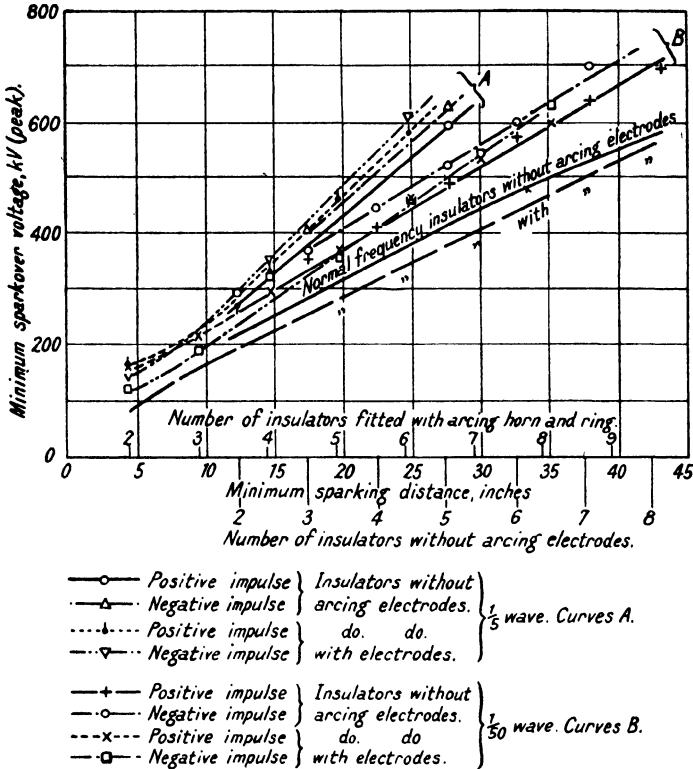

FIG. 206. MINIMUM IMPULSE SPARK-OVER (DRY) AND IMPULSE RATIO OF PORCELAIN CAP AND PIN-TYPE INSULATORS
 Diameter 10 in., spacing 5 in.
 (From a paper by Messrs. Allibone, Hawley and Perry)

value due to humidity is, for waves between 0.5/5 and 1.5/40, about 1.75 per cent per grain per cub. ft.

The effect of humidity on the gap is such that the minimum spark-over value for a given gap setting increases as the humidity increases. The rate of this increase is greater the greater the gap setting. Increase of humidity increases the time-lag for a given spark-over value, but this increase of time-

lag with increase of humidity becomes less as the spark-over value increases. The maximum time-lag decreases as the humidity is increased. As the spark-over value is increased, all

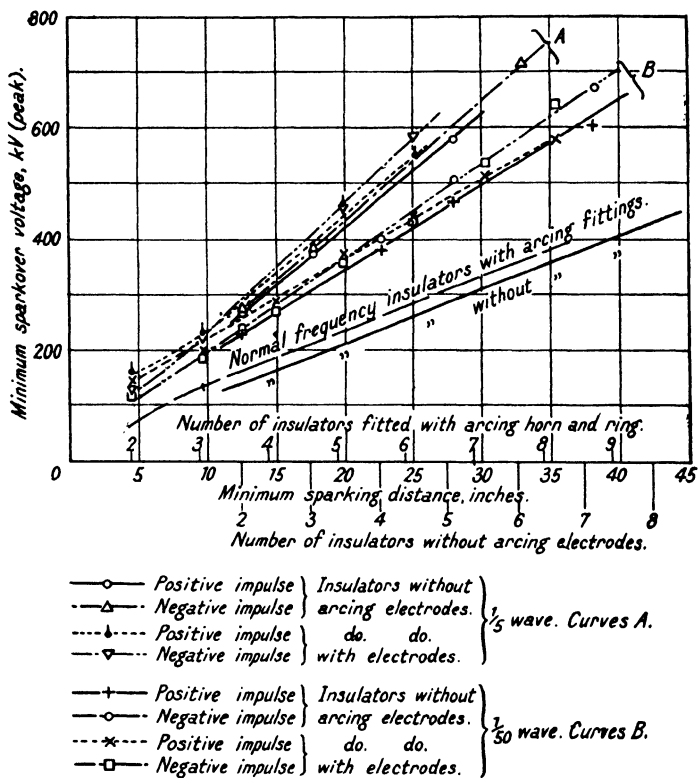

FIG. 207. MINIMUM IMPULSE SPARK-OVER (WET) AND IMPULSE RATIO OF PORCELAIN CAP AND PIN TYPE SUSPENSION INSULATORS

Diameter 10 in., spacing 5 in.

(From a paper by Messrs. Allibone, Hawley and Perry)

time lag-curves tend to converge. Therefore the effect of wave shape is only of importance on minimum spark-over value.

Relative Air Density. The variations due to relative air density are of the same kind as those for humidity. This might be expected from the modern physical theory of the spark.

Rainfall. The minimum spark-over value increases under rain conditions on that obtained when dry, although the effect is less the shorter the time-lag.

Time-Lag. In all cases the time-lag of a given gap is less the greater the applied voltage of spark-over. According to Allibone, Hawley and Perry, the time-lag for a given wave shape is higher for a positive wave than for a negative wave; and according to Fielder, the time-lag for a given spark-over value is higher for a negative wave than for a positive wave. These two findings are not at variance as may first appear. The Allibone time-lag variation refers to that obtained with minimum spark-over value between positive and negative waves on a given gap, whilst the change in time-lag given by Fielder is that which occurs at any particular spark-over value on a given gap between positive and negative waves.

The theory of impulse spark-over on gaps and over insulation surface, etc., is very complex, and the authors would refer those interested to the paper by Allibone, Hawley and Perry quoted above.

In Fig. 205 is shown a typical rod gap, and the settings given in Table XVIII are taken from the A.I.E.E. lightning and insulator sub-committee report, 1934. In Figs. 206 and 207 are curves for cap- and pin-type porcelain insulators.

BIBLIOGRAPHY

- T. E. Allibone, W. G. Hawley, and F. R. Perry, *J.I.E.E.*, Nov., 1934.
A. L. Atherton, *Elec. Journal*, Feb., 1929.
E. Beck, *Elec. Journal*, Feb., 1929.
P. L. Bellaschi and F. J. Vogel, *J.A.I.E.E.*, June, 1934.
Brown-Boveri Review, Aug., 1931.
C. Dannatt and J. W. Dalgleish, *Electric Power Transmission and Inter-connection*. (Pitman.)
K. B. McEachron, *G.E. Rev.*, May, 1928.
V. M. Montsinger, W. L. Lloyd, and J. E. Clem, *J.A.I.E.E.*, June, 1934.
S. Murray-Jones and R. A. Hudson, *Elec. World*, Oct., 1929.
E. T. Norris, *Elec. World*, Jan., 1929.
A. M. Opsahl, *Elec. Journal*, 1930.
J. F. Peters and J. Slepian, *J.A.I.E.E.*, Aug., 1923.
B. F. J. Schonland and T. E. Allibone, "Branching of Lightning," *M.-V. Gazette*.
J. Slepian, R. Tanberg, and C. E. Krance, *A.I.E.E. Trans.*, 1930.

CHAPTER XIII

OUTDOOR HIGH VOLTAGE FUSES

THE high voltage fuse is a complementary piece of apparatus to the air-break switch, and is used in combination with it in cases where, for economic reasons, the installation of an oil circuit-breaker is not warranted. Its chief application is that of protecting the high voltage winding of the power transformer, and in this respect it performs a duty which differs in principle from that usually imposed on the low voltage fuse. The function of the fuse connected to the high voltage side of the transformer is to disconnect the circuit in the event of a short-circuit in the transformer itself. This disconnection should be accomplished within a time short enough to prevent the circuit-breaker controlling the transmission line from being opened by its trip mechanism. Overloads or short-circuits on the low tension system should be isolated by the operation of circuit-breakers or fuses on the low tension side, and should on no account blow the high voltage fuses, since, should the latter occur, the complete supply from the transformer would be cut off. Failure to realize this simple truth is often the reason why high voltage fuses of a too small current rating are used; the annoying consequence of which practice is the unnecessary shut down of the system under fault conditions. The capacity of the high voltage fuse should therefore be determined by the minimum short-circuit current that can occur at the point of the system at which the fuse is installed, and not by the kVA. rating of the transformer which the fuse is to protect. The inverse time characteristic inherent in all fuses makes them unsuitable for dealing with short-circuits because, under such fault conditions, the circuit must be opened in the minimum of time. It is usually possible, however, to obtain a fuse with a current rating which is sufficiently high to prevent inadvertent blowing on low voltage faults, but small enough to allow the fuse to blow on short-circuit faults with a small time lag. The modern outdoor power transformer has reached a high level of reliability, and the fuses protecting it will seldom be called upon to operate. This point is mentioned because some engineers are insistent that fuses shall be capable of

replacement from ground level. This feature necessitates additional expense, which can hardly be justified in view of the rare occasions that fuses blow on short circuit.

There are many designs of fuses, and these vary in capital cost as much as they do in appearance and efficiency. A few typical ones are described later, and these may be taken as representative of h.v. fuse practice in general. The principal difficulty that faces designers is that the expense involved in testing out and perfecting any particular type may easily exceed the profits that are likely to be earned over a considerable period.

The Carbon-Tetrachloride Fuse. One old and popular type of fuse is that commonly known as the carbon-tetrachloride fuse. This was originally introduced by Messrs. Schweitzer & Conrad, but is now manufactured by several other makers.



FIG. 208. HIGH VOLTAGE LIQUID FUSE
Allen West & Co.

The complete unit of this type of fuse is enclosed in a steam gauge glass tube which is sealed at both ends by brass ferrules, which ferrules also form the contacts. One end of the fuse wire is attached to one of the contact ferrules, whilst the other end is attached to the end of a tension spring. The other end of this tension spring is fixed to the other ferrule. Thus the fuse wire is kept in a state of tension. A copper braid shunt is provided to relieve the spring of current-carrying duty. The remaining space within the tube is filled with a non-inflammable liquid possessing a high dielectric strength. The melting of the fuse element releases the spring, and thereby gives a quick-break action to the arc. The liquid is forced into the arc stream by means of a director. Most fuses on this principle are mounted vertically with the fuse wire at the top. The exceptions to this rule are the 88 kV., 110 kV. and 132 kV. fuses manufactured by Messrs. Allen West & Co., Ltd. (Fig. 208). These fuses are mounted horizontally and are similar in appearance to two normal fuses in series. The fuse wire takes up a central position with a spring at either end. A central metal portion provides a fixing for the glass tubes and has a safety vent incorporated in it.

At voltages up to 66 kV. complete rupture in one half-cycle is possible, and breaking capacities up to 400 kVA. at 33 kV. and 750 kVA. at 66 kV. can be obtained. Tests made by the Central Electricity Board, England, on Allen West 132 kV. fuses proved them capable of rupturing successfully 992 000 kVA. at 132 kV., 50 cycles. The time of rupture given by one test was 0.0213 sec. or 1.065 cycle, and for another 0.0404 sec. or 2.02 cycle.

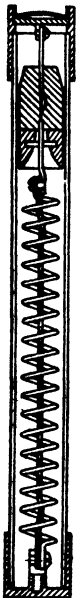

FIG. 209
TYPICAL
EXAMPLE
OF A
CARBON-
TETRA-
CHLORIDE
FUSE

The principal points to note in connection with this type of fuse are—

(1) It is of single-pole operation, viz. the blowing of the fuse on one of three phases does not open the other two.

(2) It is delicate to handle due to the glass tube.

(3) After operation the fuse must be returned to the makers for rewiring.

The “Quenchol” Fuse. A fuse that is free from the latter complaint is the “Quenchol” fuse made by the General Electric Co., Ltd., England. This has a screwed top which serves the dual purpose of safety-valve container and access point for rewiring and refilling. The rewiring and refilling operation can be carried out quite satisfactorily by the user.

Fig. 209 shows a typical example of fuses of the types referred to above.

The Oil-Blast Fuse. The only high voltage fuse known to the authors, which disconnects all three phases in the event of a single phase fault, is that manufactured by the British Thomson-Houston Co. Ltd., and known as the “Oil-Blast Fuse,” and although this was originally developed for 132 kV., lower voltage units are available. This design was suggested by the high efficiency of the oil-blast oil circuit-breaker explosion pot. The fuse container

takes the form of a porcelain shell similar to that used for the air end of an oil-filled bushing. A steel plate is bolted to the bottom of this shell, and attached to this plate, and within the porcelain shell is the moulded bakelite explosion chamber, similar to that shown in Fig. 124. Space is also provided for twelve displaced fuse ferrules.

The fusing element is an independent unit consisting of a glass tube with metal end ferrules, which protect the fuse wire

from damage and relieve it from mechanical stress. This fuse unit is screwed at one end to a contact lifting rod, and at the opposite end it engages with a spring collar type of fixed contact. This contact holds the fuse and lifting rod assembly against the action of an opening spring attached to a metal

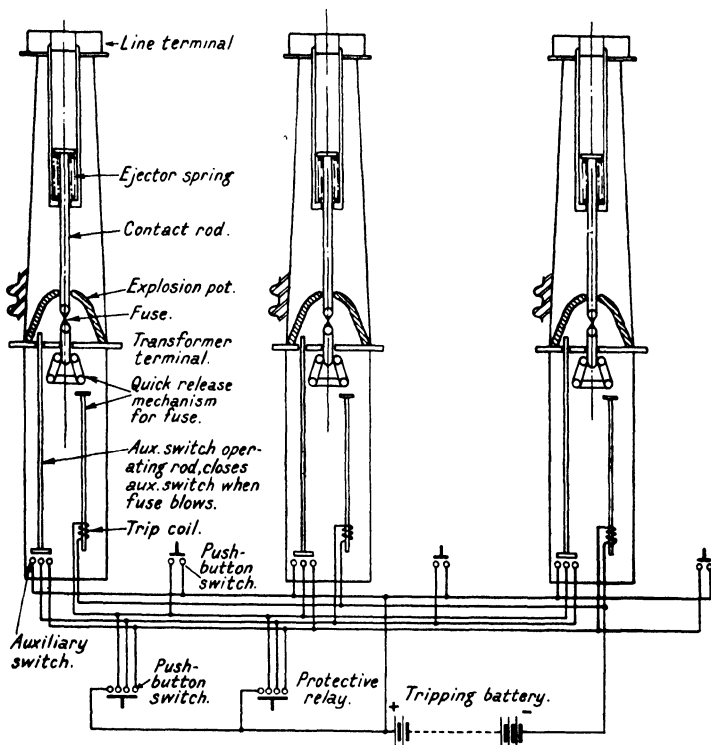

FIG. 210. DIAGRAM SHOWING OPERATION OF BRITISH THOMSON-HOUSTON OIL BLAST FUSE

hood at the top of the porcelain shell. The porcelain shell or container is filled with oil to a point just above the mouth of the explosion chamber. The melting of the fuse wire shatters the glass fuse container and thus releases the lifting rod, which now moves upwards at a speed of approximately 25 ft. per sec. The arc is extinguished in the explosion chamber by the oil-blast action in a manner similar to that which occurs in the oil circuit-breaker. The complete unit is mounted on a post

insulator, the connections to the fuse being taken from terminals fixed to the top and bottom fittings of the porcelain shell container.

Reloading of the unit is carried out by removing the top hood, extracting the lifting rod, screwing a new fuse unit to its end, re-inserting the lifting rod, and forcing it to the closed position by a ramrod. As the new fuse enters the fixed contact it displaces the old fuse ferrule. An alternative scheme is to mount the complete fuse within the terminal bushings of a transformer. The interlocking arrangement which operates all phases on the blowing of any one fuse is shown in Fig. 210.

The fuse ferrule is held in a quick release mechanism which is operated by a trip coil. The trip coil circuit, which is fed from a suitable battery, is completed by an auxiliary switch, the operating rod of which is brought into the explosion chamber. The pressure generated within this explosion chamber when the fuse blows pushes the operating rod downwards, and thus closes the auxiliary switch contacts. The trip coil and insulated operating rods for the auxiliary switch and trip mechanism are enclosed in a porcelain housing situated underneath the metal plate holding the explosion chamber. The same trip circuit can be utilized for remote hand tripping or protective relay operation.

This fuse has been tested by the Central Electricity Board; the result of this test showed that 580 000 kVA. was ruptured in 1.2 cycles with no apparent distress.

Although the fuse is similar to an oil circuit-breaker in operation, the time taken for reloading or closing the fuse is appreciably longer than that required for reclosing an oil circuit-breaker. After first disconnecting the complete unit by means of an isolating switch, the fuse of each phase must be examined and new fuse elements fitted where necessary.

The "**Expulsion**" Fuse is a further type of single-phase fuse which is extensively used for outdoor service. It is one of the most economical to purchase and to maintain. Although its principal application is at voltages below 66 kV., there are units up to 132 kV. that are giving satisfactory service. A typical fuse of this type is shown in Fig. 211.

The general design of the expulsion fuse is similar in all



FIG. 211
TYPICAL
EXAMPLE
OF AN
EXPULSION
FUSE

makes, although various refinements, some of which will be dealt with later, are included by certain manufacturers. In the example illustrated, the fuse element consists of a double twisted fuse wire which passes from beneath a pinching screw in the bottom ferrule, up the centre of the insulation tube and partly through the top ferrule or expulsion chamber. At this point the twisted wire ends, and a single strand of it only is carried on through the remainder of the chamber and clamped at the top. This simple arrangement ensures that rupture will occur at the single strand in the expulsion chamber. The high internal pressure generated by the initial arc creates an expulsion action down the centre of the insulation tube. This action discharges what is left of the fuse element together with the arc products.

From this description it will be apparent that the material used for the insulating tube plays an important part in the efficient operation of the fuse. Most paper product tubes are unsuitable for the purpose, as the arc burns a conducting track which, after a few operations, is continuous from end to end. High grade fibre is one of the best materials for this purpose, as, apart from being track-free, the gases liberated from the fibre by the arc aid in the extinction of the latter.

A modification to the arrangement which is made by the General Electric Co. of America is the fitting of a spring within the bottom ferrule to put tension on the fuse element. The fuse element in this case comprises the single strand of fuse wire and a piece of high resistance steel wire in parallel with it. The steel wire takes the tension of the spring, and thus relieves the fuse wire of this stress. Then the fuse blows, the steel wire takes the full fault current, and the heat this generates in the wire together with the heat from the arc of the fuse quickly melts the steel wire. The function of the spring is to aid in the quick extraction of the unmelted portion of the fuse element, and is particularly useful at low current values when the pressure generated in the expulsion chamber is small.

Breaking capacities of the following order can be expected from this type of fuse: 100 000 kVA. at 33 kV. and 150 000 kVA. at 66 kV.

BIBLIOGRAPHY

- P. Altburger, *Elektrizitätswirtschaft*, Dec., 1933.
Henderson, *Automatic Protective Gear for A.C. Supply Systems*. (Pitman.)

CHAPTER XIV

RELAY PROTECTIVE GEAR

THE protection of electric circuits had developed to a high degree of efficiency before the advent in this country of outdoor high voltage transmission. Nevertheless, the use of very high voltages for various kinds of power transmission schemes necessitated methods of protection peculiar to themselves. As a result, a number of protective devices has been designed for particular application to high voltage networks.

The British Grid is a good example of a high voltage scheme, and the types of protective gear applied to it will provide sufficient explanation for the application of protective methods to high voltage schemes in general. In the first place, it is necessary to describe the different types of protective systems, and then to proceed to their application.

Six types of such systems will be considered, and these may be taken as representative of high voltage protective practice as a whole. Some of these are pilot systems and others non-pilot systems. It should be obvious that non-pilot systems find their principal application to long distance feeders, where the cost of pilots would be prohibitive. For all systems it is generally agreed that solid earthing of the neutral point is preferable for protective gear operation. A large percentage of faults on overhead line systems are earth faults, and a solidly earthed system enables more sensitive protection to be obtained on earth faults than is to be obtained on unearthed systems. Also, it should be appreciated that when a fault occurs on a network, the fault current may be carried by healthy feeders as well as by the unhealthy ones. Again, under certain conditions, it is possible for the fault current to be of smaller value than that of the normal full load current of the line.

The Translay System. This is a pilot wire current balance system. The principle of its operation is based on the fact that, in a healthy feeder, the current entering at one end is equal in magnitude and phase to the current leaving at the other.

The relay used with this system is of the induction type, and, briefly, functions as follows (see Fig. 212). A primary winding 1 is wound on the laminated magnet core 2, and energized by

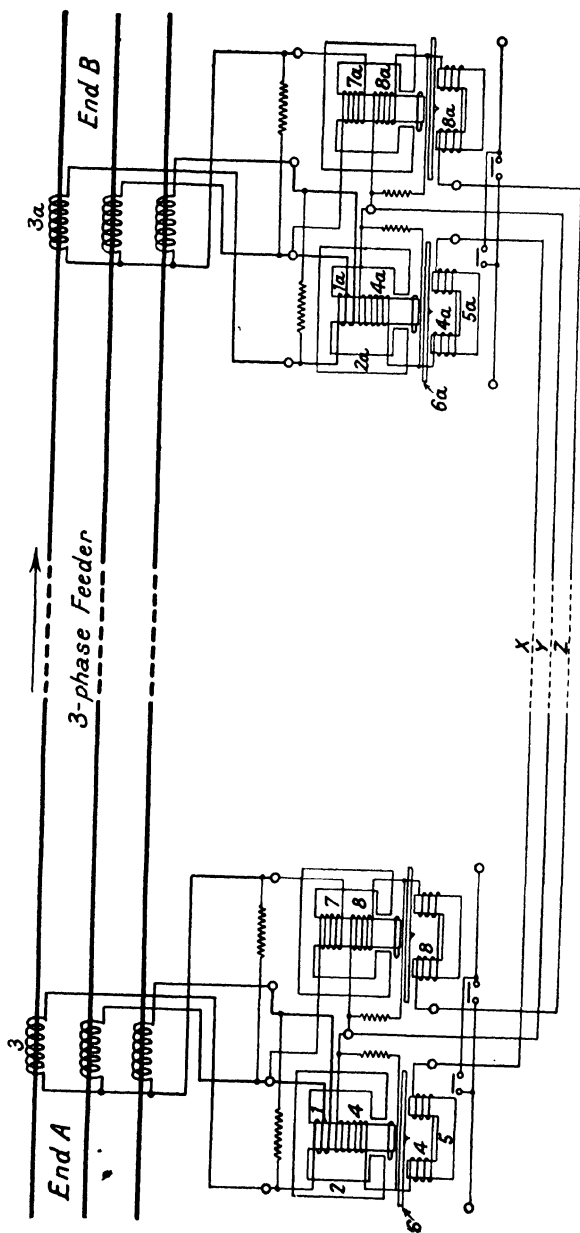

FIG. 212 TRANSLEY PROTECTION OF THREE-PHASE FEEDER

a current transformer 3. A secondary winding 4 is connected in series with the lower element magnet 5, as shown in the figure. Thus the flux created in the magnet 2 by the current in the winding 1, induces a current in the winding 4 that in turn creates a flux in the magnet 5. These fluxes are in quadrature, and interact to cause eddy currents in the disc 6. The interaction of these fluxes and eddy currents causes the disc to rotate.

The trip coil contacts are mounted on the rotating disc and close the trip circuit when the relay operates. Various compensating devices are included for damping and pilot capacity bias, etc. A second element

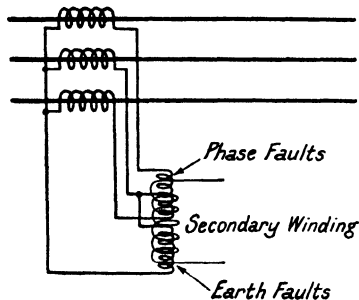

FIG. 213. DIAGRAM ILLUSTRATING SUMMATION OF THREE-PHASE CURRENTS FOR PROTECTIVE RELAYS

with windings 7 and 8 operates on the same principle, but this element is connected so as to respond only to earth leakage faults.

If two such relays are connected to current transformers at each end of a feeder, as shown in Fig. 212, and the secondary circuits connected in series through pilot wires, then, when the same current flows through both current transformers, a condition of

balance may be obtained due to the induced voltages in the two secondary windings being in opposition. Under such conditions the relay does not operate. Any difference between the current entering through the current transformer 3 and that leaving through the current transformer 3a, will, however, result in an out-of-balance in the voltages induced in the windings 4 and 4a, and thus a current will flow through these two windings by way of the pilots. The flux that results in the magnet 5 from this out-of-balance current, will react with that in the magnet 2, and with the disc 6 to operate the relay.

Such relays are made for phase-to-phase faults and earth leakage protection. A separate element is used for each when it is desired to have independent control of phase-to-phase fault and earth leakage settings. If separate earth leakage setting adjustment can be sacrificed, then a single element relay will suffice for both purposes. In this case the windings are arranged as those shown in Fig. 213. Here it will be seen that

there are two phase-fault windings and a summation winding for earth faults.

Current setting for both kinds is obtained by turning a small knob which adjusts the tension on the spiral spring that controls the relay disc. The relay has a slightly inverse time characteristic, as shown by the curve in Fig. 214, and stability on through faults is obtained by means of a biasing loop on the relay that produces a backward or restraining torque.

Impedance System—Definite Impedance Relay. This is a non-pilot wire system, and, as the name implies, functions in accordance with the impedance of the line to be protected. The

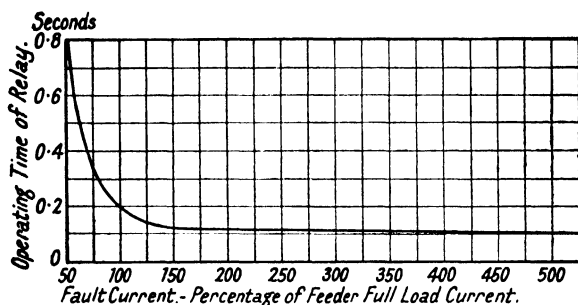

FIG. 214. CURVE SHOWING RELATION BETWEEN FAULT CURRENT AND OPERATING TIME OF RELAY

impedance of any given line is practically constant, and therefore the impedance of any section of a line varies directly as the length of that section. Also, impedance is represented by $Z = E/I$; hence, if I represents the current through the line and relay, the voltage E across the relay will be proportional to Z , the line impedance. A relay may then be constructed with an operating coil that is energized by current transformers, and a restraining coil energized by voltage transformers each acting in the required ratio. The Metropolitan-Vickers Co. adopt this principle in their type "FZ" definite impedance relay. In this, two armatures are mounted, one at each end of a balanced beam. One armature is attracted by the current coil element and the other by the voltage coil element. Thus the pull on the armature of the voltage coil element is designed to be directly proportional to E , and inversely proportional to I ; or the operation of the relay is proportional to $E/I = Z$.

352 OUTDOOR HIGH VOLTAGE SWITCHGEAR

In Fig. 215 a diagrammatic sketch is given which is self-explanatory. It is clear that the relay can be wound for any required value of E/I , such that any value below the chosen one will cause the relay to operate. Furthermore, operation is almost instantaneous within the feeder section that the relay covers, whilst outside that section it is inoperative. In the interests of stability, the relay is generally designed to protect 75 per cent of the feeder length; the remaining 25 per cent being protected by a back-up relay also of the impedance type.

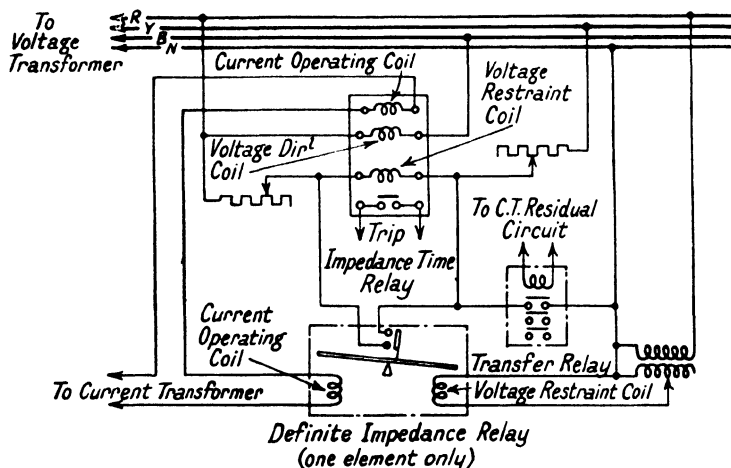

FIG. 215. DIAGRAM SHOWING METHOD OF INTERCONNECTING DEFINITE IMPEDANCE (TYPE FZ) AND IMPEDANCE TIME (TYPE NZ) RELAYS, USING TRANSFER RELAY

Connections are shown for one phase only.

Impedance/Time Relay. This back-up relay is known as the impedance/time relay, and is a discriminative relay based on the principle that operation will take place in a time dependent upon the distance of the fault from the relay. Thus a series of such relays, placed at different points along a line, would give correct discriminative protection, since, on the occurrence of a fault, the relays would automatically select their own times of operation, according to their distances from the fault. The relay nearest the fault would operate in the shortest time, and that farthest away in the longest time.

The explanation of the way in which the desired characteristic is achieved lies in the fact that, as the time of operation

Fig. 212. It is different in so far that the primary winding of this current element has a number of tappings which enable a corresponding number of different current setting values to be obtained. There is also a voltage element which consists of a magnet 1 and an armature 2. The magnet winding is

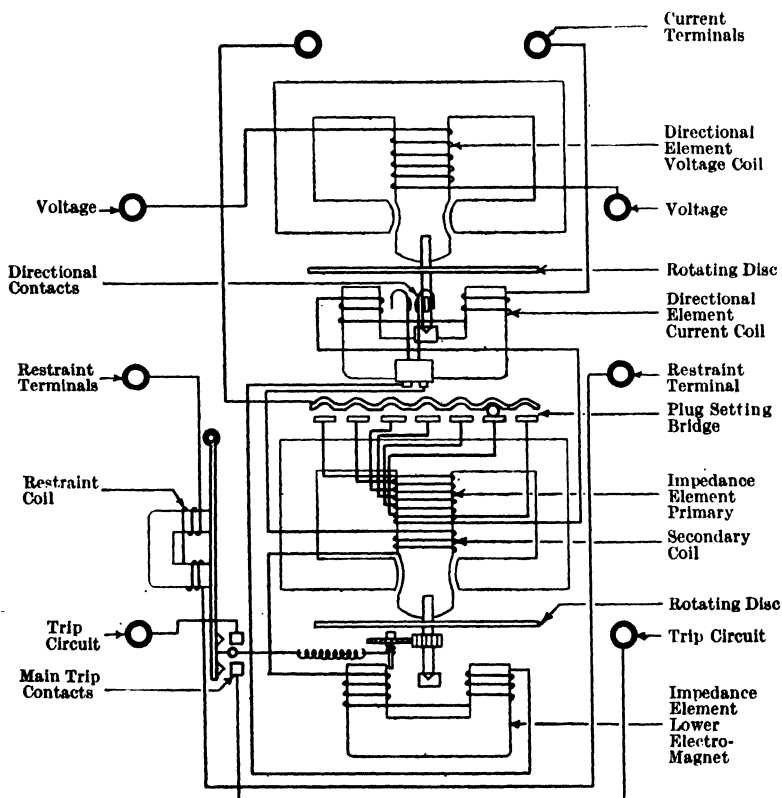

FIG. 217. DIAGRAM OF CONNECTIONS OF THE TYPE "NZ" DIRECTIONAL IMPEDANCE TIME RELAY

energized from the voltage of the system. The armature is coupled to the spindle 3 which carries the contact lever 4. The rotating disc 5 drives the spindle 6 through a gear. This spindle 6 is coaxial with the spindle 3, and these two spindles are coupled through the medium of the spiral spring 7. Thus, the greater the current through the relay, the greater the torque transmitted by the disc 5 to the spindle 6, and, by the

winding up of spring 7, this torque is passed on to the spindle 3, by which it exerts a pull against the restraining pull of the voltage element. The lower the voltage across this element, the lower the restraining pull on the armature 2. Therefore, the relay truly functions in accordance with E/I .

There are two kinds of impedance/time relays made by the Metropolitan-Vickers Co.; one, the type "PZ," which is non-directional, and the other, the type "NZ," which has a directional feature. The latter is shown diagrammatically in Fig. 217. The directional element, shown in the top portion of the diagram, comprises a voltage and current winding, the fluxes

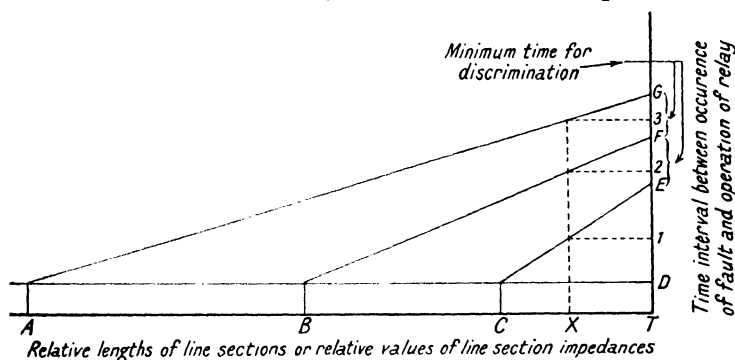

FIG. 218. TIME/DISTANCE CURVES FOR IMPEDANCE/TIME RELAYS

from which interact with the induced eddy currents in the disc to cause disc rotation. It will be clear that the direction of disc rotation will depend on relation between the currents in the current and voltage elements. A reversal of current in the current element will cause a reversal of the disc rotation. For normal current direction, the disc is held against a stop; whilst a change in current direction will cause the disc to rotate and close the directional contacts as shown in the figure. These contacts are made to complete the secondary winding of the impedance element: thus the impedance element is inoperative until the directional element has performed its function, which means that the relay is sensitive only to faults in a given direction.

Characteristic curves for these relays are shown in Fig. 218. These are in the nature of time-distance curves. Thus, in the figure, AT represents a transmission line, which is divided into three unequal sections AB , BC and CT . At the end of the line at A and at the junction of the sections B and C , it is

assumed that impedance/time relays are installed for the purpose of protecting their own section of the line, and of acting as back-up protection to the relays in the succeeding sections. Thus, for the section of line CT , the impedance/time relay at C would be set for the length of line CT , and would have the characteristic CE , i.e. a fault at C would operate the relay at C after the time interval CD , whilst a fault at T would operate the relay at C after the time interval TE . The relay at B would be set for a section of the line of length equivalent to $(BC + CT)/2$. This would give the relay at B the characteristic BF . Similarly, the relay at A would be set for a section

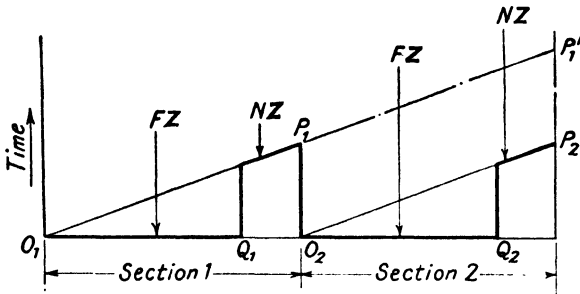

FIG. 219. CHARACTERISTIC DIAGRAM OF IMPEDANCE RELAY PROTECTION OVER TWO LINE SECTIONS

of the line of length equivalent to $(AB + BC + CT)/3$, and this would give the relay at A the characteristic AG . Now, suppose a fault at a position X on the transmission line, then the relay at C should operate to clear this fault in the time $T1$. If the relay at C were to fail, the relay at B would act as back-up protection and would operate in the time $T2$. In the same way, the relay at A would operate in the time $T3$ should the relays at both B and C fail to function, or should the circuit-breaker trip mechanism at those points fail to act. Thus it is seen that each relay acts as a back-up protection to the relay preceding it. Fig. 219 shows a typical operation curve for definite impedance protection with impedance/time relays as back-up protection.

Lock-in System. This is a pilot wire lock-in system based on the work of C. E. Longfield. It takes its name from the special feature whereby, on the occurrence of a fault, relays operate to lock in, and thus prevent the operation of protective relays on all sections of a feeder except that nearest to the fault. The

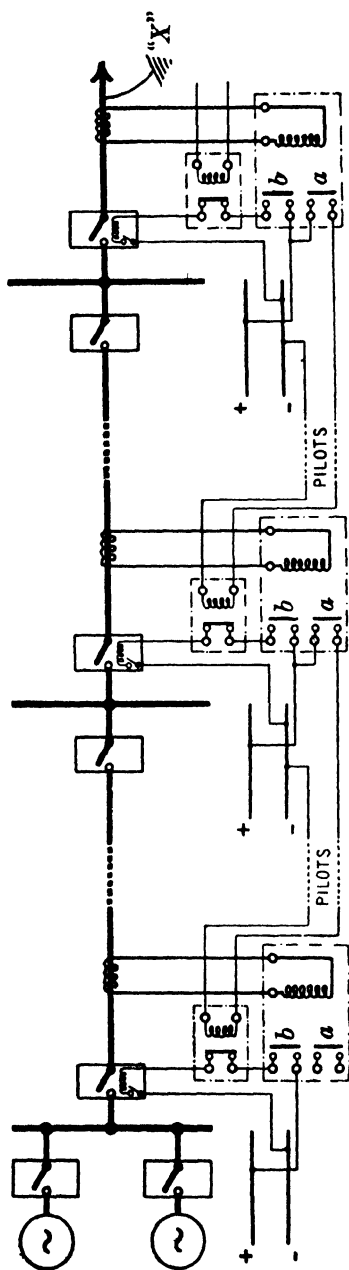

FIG. 220. INTERLOCKING OVERLOAD PROTECTION (LONGFIELD SYSTEM)
Overload relay contacts *a* operate instantly, and contacts *b* after 0.1 second.

system can better be followed by reference to Fig. 220. It involves the aid of d.c. pilot wires, and because of this, telephone lines may be used for the purpose without any risk of interference with the telephones. A protective relay is employed at each section point, which relay is fitted with two contacts *a* and *b*. The connections are made in accordance with the figure, and the manner of operation is that, in the event of a fault at a position *X*, all current transformers between *X* and the supply point are energized to operate their respective protective relays. The contacts *a* of all these relays close instantaneously, and the contacts *b* after 0.2 sec. The closing of the contacts *a* energizes all the lock-in relays at the preceding points. Thus all the lock-in relays function except that at the point nearest to the fault *X*. The function of the lock-in relay is to open the trip coil circuit so that, when the contact *b* of the protective relay closes after a delay of 0.2 sec., the trip circuit is already open-circuited by the lock-in relay, and the circuit-breaker is thus unaffected. As the lock-in relay at the point nearest the fault is not energized, it does not open the trip circuit of this circuit-breaker. Therefore, after the brief delay of the protective relay at this nearest point, the contact *b* closes and trips the circuit-breaker which is nearest to the fault. It will therefore be seen that proper discrimination is obtained on any number of feeder points in series, with a maximum time lag of only 0.2 sec.

The protective relay may be of various kinds; over-current, earth leakage, directional or non-directional, etc., and thus the lock-in system is applicable to either radial feeder or ring main schemes, and so on.

Split-pilot System. This is a pilot wire balance system, and was evolved by Messrs. A. Reyrolle & Co. Ltd. The scheme is shown diagrammatically in Fig. 221, whence it will be observed that the current transformer secondaries are coupled by three pilot wires through two differentially wound relays. In the figure, (*a*) shows the condition for a healthy line. In this case there is balance between the current transformers, and any capacity current likely to flow in the pilot wires will split up from 1 between 2 and 3, and thus produce no effect on the differentially wound relays. Again, under such healthy conditions, the potentials at the mid-points of the pilot wires due to a through current will be the same, and no disturbance to the general balance of things will therefore result if these points

are connected together. The tripping connection is shown in (b) of the figure, between the mid-points *X* and *Y*.

In the event of a fault within the protected area, balance is upset, and the transformer secondary currents are distributed through the pilots in accordance with the impedances of the different pilot sections. Now *Y* being the mid-point of one of

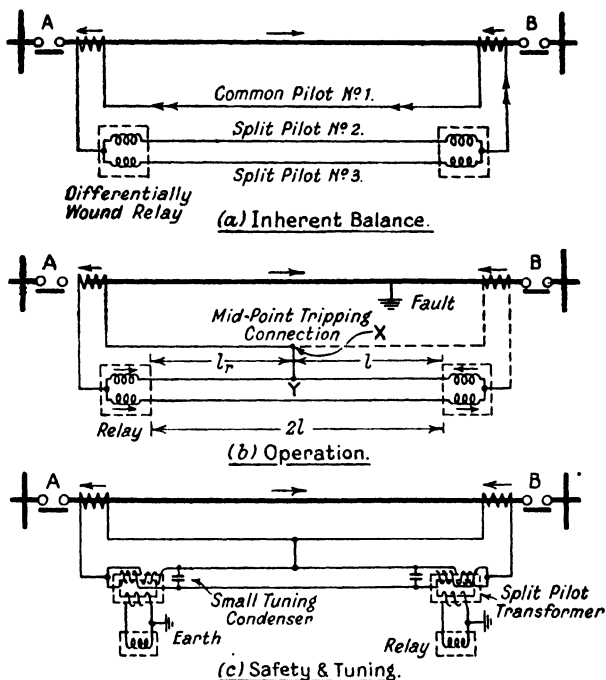

FIG. 221. DIAGRAM ILLUSTRATING PRINCIPLE OF SPLIT-PILOT PROTECTIVE SYSTEM

the split pilots, and $2l$ the length of pilot between the differential relays, the relative impedances of the two parallel paths for the current from the current transformer at the *A* end, will be 3 to 1. Thus the relative currents through the differential relay at the *A* end will be in the proportion of 1 to 3; or there will be an out-of-balance current to operate the relay of magnitude $3 - 1 = 2$. The currents through the relay at the *B* end are $1 + 1 = 2$. Thus both relays will operate to isolate the faulty section. The effect of the current transformer at the *B* end, although it changes actual current values

somewhat, does not disturb the relation between the currents in the differential relay coils.

In Fig. 222 is shown the diagram for split-pilot protection for extra high voltage lines, say from 44 to 220 kV. The principal difference between it and the system shown in Fig. 221 (which is usually applied to feeders below 44 kV.) is that solid core current transformers are employed instead of distributed air gap transformers. Tuned relays are used in both systems

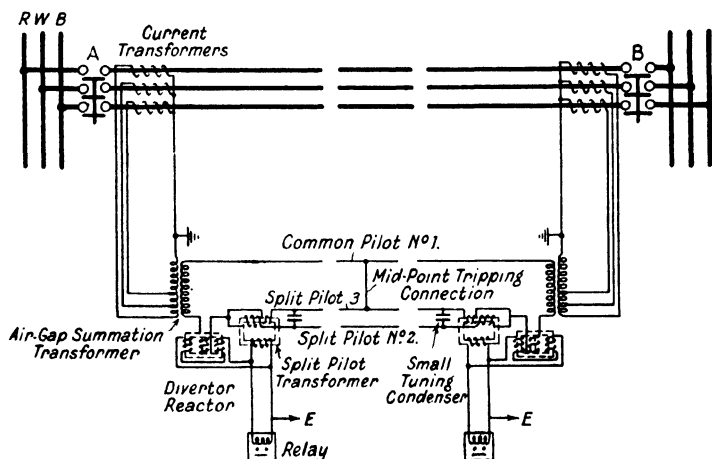

FIG. 222. DIAGRAM SHOWING SPLIT-PILOT PROTECTION SYSTEM FOR VOLTAGES UP TO 220 kV.

and these are responsive only to currents of normal frequency, and are therefore immune from wrong operation by oscillatory currents created by fault conditions in other sections.

Ratio-balance System. This is a non-pilot system somewhat akin to the impedance system already described. The ratio-balance system, however, functions on line reactance instead of on line impedance, and, in consequence is independent of the effect of the variation of arc resistance. This scheme, which is sponsored by Messrs. Reyrolle & Co. Ltd., is shown diagrammatically in Fig. 223. It is essentially a distance measuring method with time qualifications, and therefore two distinct elements are involved. The distance measuring element operates as follows: There are two magnetic systems *A* and *B*, see Fig. 223, both of which act upon an induction member, shown in the figure as a disc. The magnetic system *A* is

energized by two coils, a current coil and a voltage coil; whilst the magnetic system *B* is energized by a current coil only. The torque on the induction member is produced by the interaction of the fluxes from *A* and *B*. No torque is produced by *A* or *B* separately.

The flux in the magnetic system *A* is proportional to the vectorial sum of the currents flowing in the current and voltage coils. It is therefore possible, by means of a phase shifting device, to adjust the phase relationship between these currents to obtain a flux in *A* proportional to

$$I - V \sin \phi/K \quad \dots \dots \dots (124)$$

where *I* is the current coil, *V* the voltage on the voltage coil, ϕ the phase angle between *I* and *V*, and *K* a constant.

The flux in *B* is proportional to the current *I*. Now in any wattmeter movement, the torque is proportional to the product of the two fluxes and a function of the phase angle between them. The latter, for the present purpose, may be considered constant, therefore the torque on the induction member can be expressed mathematically by—

$$T = c [I - (V \sin \phi/K)] I$$

where *c* and *K* are constants.

Therefore

$$T = cI^2 - c/K (VI \sin \phi) \quad \dots \dots \dots (125)$$

Thus it is seen that the expression for the torque consists of two terms, of opposite sign. The relay is arranged to operate to close its trip contacts when the first term exceeds the second, and is restrained against the stop when the second term exceeds the first. When the vectorial difference between the two terms is equal to zero, the relay is on the point of operation. Or, the relay is on the point of operation when—

$$CI^2 - (c/K) VI \sin \phi = 0$$

Hence,

$$V \sin \phi/I = K \quad \dots \dots \dots (126)$$

This means that the relay will operate at or below a constant value $V \sin \phi/I$, whence it derives its name *reactance relay*.

The time element comprises a clock that gradually inserts resistance into the voltage coil circuit of the distance element, thus reducing the flux produced by *V*. Suppose the flux produced by *V* is in consequence reduced at a rate directly

proportional to the time t . Then, in equation 126, substitute V/t for V , and the expression becomes—

$$V \sin \phi / tI = K$$

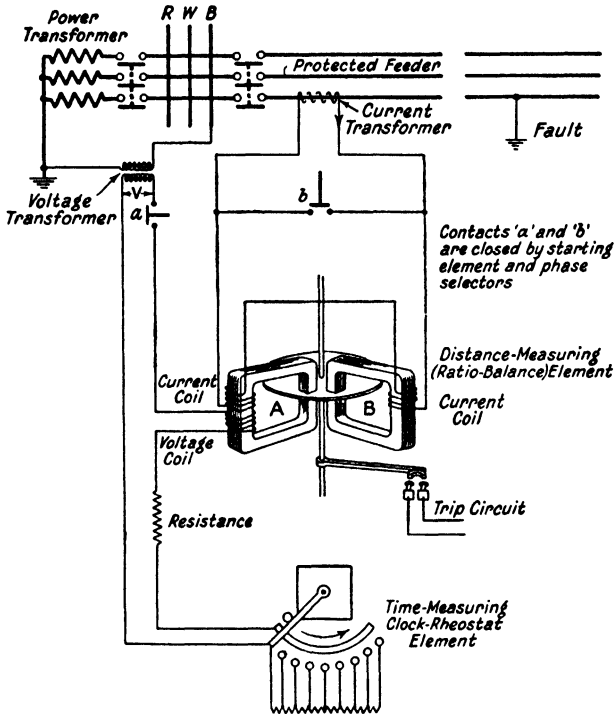

FIG. 223. DIAGRAM ILLUSTRATING THE PRINCIPLE OF THE TIME-DISTANCE DISCRIMINATING UNIT OF REACTANCE TYPE RATIO-BALANCE PROTECTIVE SYSTEM

OR

$$t = (1/K) \times (V \sin \phi / I) \dots \dots \dots (127)$$

Thus the tripping time of the time element is proportional to the reactance $V \sin \phi / I$.

The windings are thus arranged so that at, or below, a definite value of line reactance, the induction element will operate instantaneously. Referring to Fig. 223, it will be noted that, on the occurrence of a fault, the contacts a and b are made to close by what are termed *starting elements* and *phase selectors*. The closing of these contacts completes the circuits through the current and voltage coils of the element. Then, if the fault be

within the limit of the reactance value for which the relay is set, operation will take place immediately. If, however, the fault be outside the first protected area, the time measuring element comes into action and gradually inserts resistance into the voltage coil circuit of the reactance element. Thus the

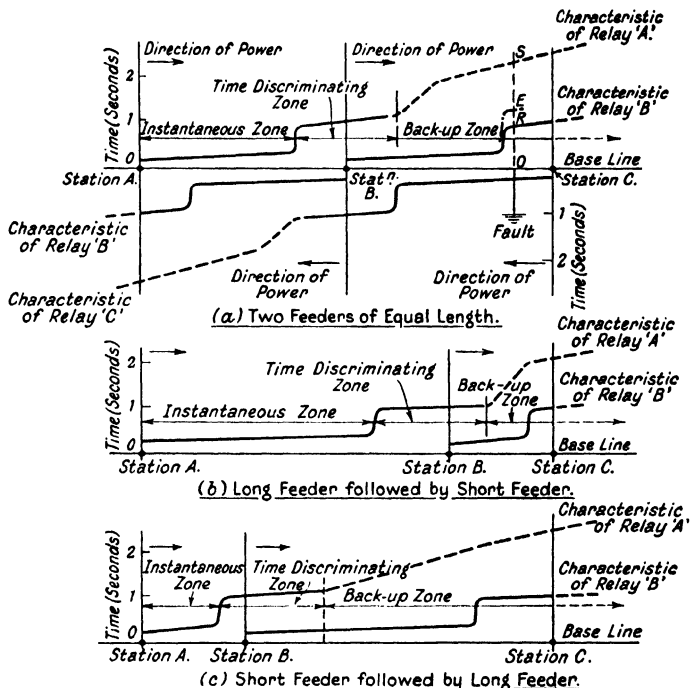

FIG. 224. DIAGRAM ILLUSTRATING TIME-DISTANCE CHARACTERISTICS OF RATIO-BALANCE PROTECTIVE SYSTEM FOR SECURING STABILITY AND DISCRIMINATION

reactance value of the relay is gradually increased, and will eventually correspond to the reactance value of the line to the fault, when the relay will then operate. It is clear that the more distant the fault, the higher will be the reactance value of the line to the fault, and therefore the longer the time delay of the relay before the correct value of resistance is inserted in the voltage coil winding. In other words, definite time discrimination is obtained.

In Fig. 224 are shown characteristic curves for this system,

from which will be seen that the relays at the different points of a line can be set to give instantaneous protection over the major portion of their own immediate section of the line, and delayed or back-up protection over the more remote sections.

Interlock System. This is somewhat similar to the lock-in system, and, by the interlock principle, actually obtains the same result of preventing all but a desired breaker from tripping. It is used in conjunction with the usual overcurrent and earth-leakage relays. Fig. 225 shows the scheme diagrammatically. It is to be observed that, in addition to the overcurrent element, there is a directional element arranged to

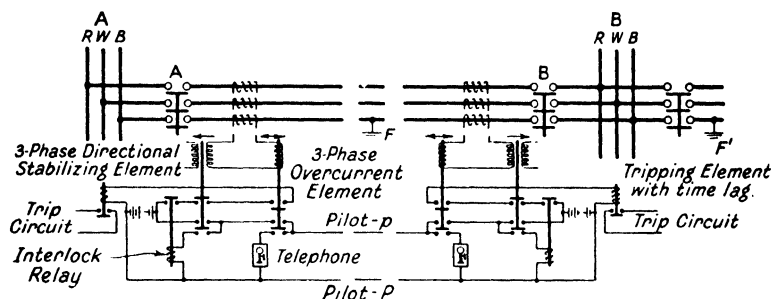

FIG. 225. DIAGRAM ILLUSTRATING "INTERLOCK" PROTECTION SYSTEM UTILIZING AN EXISTING PILOT CIRCUIT

operate only when the fault current flows away from the protected section of the line. Both these elements are instantaneous in operation.

The *modus operandi* is, that when a fault occurs within the protected section, say at F in the figure, the fault current will flow from the bus-bars inwards to the fault. The directional elements will therefore be unaffected, and the overcurrent elements alone will operate, and in doing so will complete the circuit from the batteries to the trip coils. They will also momentarily isolate the telephone lines P, p . Thus the circuit-breaker at each end of the section is tripped after a delay of 0.3 sec., and the faulty section isolated.

In the event of a fault outside the section, say at F' , there will be a current through the B end in a direction that will operate the directional element at this end. The overcurrent elements at each end will also operate, and, as for the former case, will interrupt the telephone lines. The operation of the directional element at the B end will interrupt the trip circuit

of the *B* oil circuit-breaker, and thus prevent the latter opening, and it will also close the battery circuit, by way of the telephone lines and lower pair of overcurrent element contacts, on to the interlock relay at the *A* end. This interlock relay will open-circuit the trip circuit of the *A* oil circuit-breaker, and thus prevent the latter opening. Therefore, the whole sequence has been to prevent the oil circuit-breakers at both *A* and *B* ends of the section from being operated, and thus the fault outside this section has caused no disturbance within the section. The various steps in the sequence should be clear by reference to Fig. 225. It will be appreciated that the time lag of 0.3 sec. in the tripping coil is necessary to allow the other elements time to function.

Application of Protective Systems to E.H.V. Schemes. As stated earlier in this chapter, it is intended to consider the application of protective systems to the British Grid scheme as being representative of e.h.v. protection practice as a whole.

In Chapter II the various kinds of station lay-outs are dealt with, and reference should be made to that chapter in order to appreciate fully the *raison d'être* of the particular protective system employed. For instance, the purpose of the three-switch station is given as that of furnishing a lay-out which will give the same switching facilities and continuity of supply as were obtainable with the old four- or five-switch station lay-out. That this saving in plant can be effected by the three-switch station is due in no small degree to the protective system used.

Whilst in this chapter only two or three of the protective systems described above are referred to, it will be appreciated that the other systems can equally well be substituted since they have generally similar characteristics.

SOME TYPICAL PROTECTIVE SYSTEMS

The "One Switch" Station—Impedance System of Protection. This is the most simple type of the British Grid station lay-out, and an example of it is to be found in the East England Area. The scheme is shown diagrammatically in Fig. 226, from which it will be seen that two tee feeders are tapped off from the main through lines. Each of these feeds a step-down transformer, with no oil circuit-breaker in the feeder between the main line and the transformer. There is, however, an oil circuit-breaker on the l.t. side of each transformer. The

one h.v. breaker of the scheme is inserted in the main line between the tapping points to the two transformers.

From current transformers mounted on this h.v. oil circuit-breaker a supply is given to the current element of a definite impedance earth fault relay "FZ"; an impedance/time earth fault relay "PZ"; an impedance/time phase fault relay "PZ"; and to two directional relays "NY." The voltage supply for the pressure coils of these relays is taken from a three-phase voltage

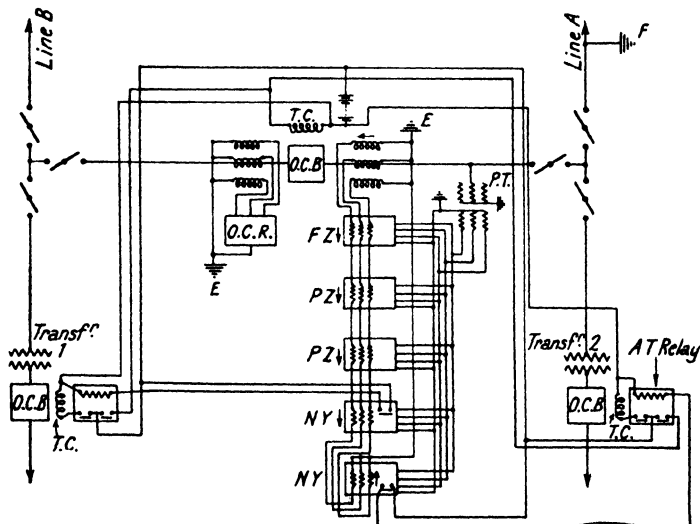

FIG. 226 SINGLE-LINE DIAGRAM OF "ONE-SWITCH" GRID STATION PROTECTIVE SCHEME.

transformer on the main line bars. It is desired that, in the event of a fault on the *A* section of the line, the h.v. oil circuit-breaker should open to prevent the fault from being fed from section *B*, and that the l.v. oil circuit-breaker controlling the *A* transformer should open to prevent a feed to the fault from that direction. Thus the supply to the *B* section would be maintained, and the fault isolated from this station. A corresponding operation occurs for a fault on the *B* section.

Refer to Figs. 226 and 227, and assume an earth fault at *F* on the *A* section. If the position of *F* is within 75 per cent of the protected line area, the definite impedance relay "FZ" will operate. Should *F* be outside the 75 per cent limit, the impedance/time earth fault relay "PZ" would operate. The

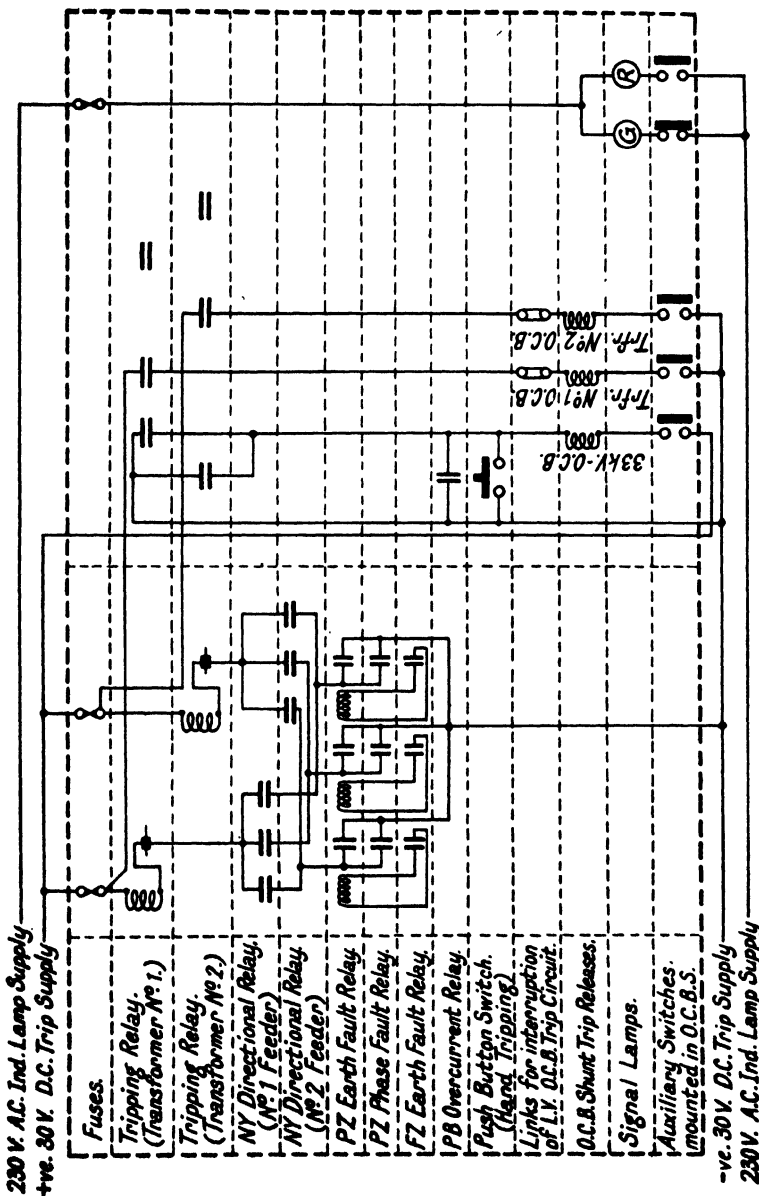

FIG. 227. SCHEMATIC DIAGRAM OF TRIPPING CIRCUITS FOR "ONE-SWITCH" STATION

operation of the type "FZ" relay is instantaneous, and its trip contacts are arranged to short-circuit the voltage restraint coil of the type "PZ" earth fault relay. The latter then operates to close its trip contacts.

From Fig. 226 it will be noticed that current is made to pass in one direction through one of the type "NY" directional relays, and in the opposite direction through the other. Therefore, there is one directional relay only that will be sensitive to a fault on a given section. For the fault at *F*, the particular type "NY" relay associated with the fault current in that direction will operate and close its trip contacts. The closing of the trip contacts of both the type "PZ" earth fault relay and the type "NY" relay completes the auxiliary supply through the coil of the tripping relay (*AT*). The latter closes the trip coil circuits of the h.v. oil circuit-breaker and that of the l.v. breaker controlling the *A* section transformer. This has the desired effect of isolating the fault from the station and maintaining the supply to the *B* section. The type "PZ" phase fault relay functions in a similar manner for phase faults. Back-up protection is provided by an overcurrent inverse time relay.

The "Three Switch" Station—Impedance and Lock-in Protective Systems. The lay-out of this station is shown in Fig. 20 and the schematic diagram of the impedance and lock-in protective systems applied is shown in Fig. 228. It will be observed from this figure that on each of the main line circuit-breakers there is a set of current transformers connected in parallel with a similar set of transformers on the coupler oil circuit-breaker.

The length of one of the main lines is given as 13.65 miles and that of the other as 4.14 miles. Now it is a limitation of impedance protective gear that the line impedance value must be above a definite figure, dependent on the system voltage, in order that the relays can make use of this feature, and in practice it is found advisable to consider, for 132 kV. lines, a length of about 8 miles as the minimum for the satisfactory application of this type of protective gear. Lower voltage lines will have correspondingly shorter lengths for the critical value. In consequence of this minimum value of line length, the longer of the two main lines shown in Fig. 228 has impedance protection applied to it, whilst for the shorter line (4.14 miles) lock-in protection is chosen. A double set of paralleled current trans-

formers is used for each purpose; the object being that, when any main line is fed by either power transformer and isolated from the other, there is always a set of current transformers in action to supply the current coils of the protective relays and thus maintain the line protection.

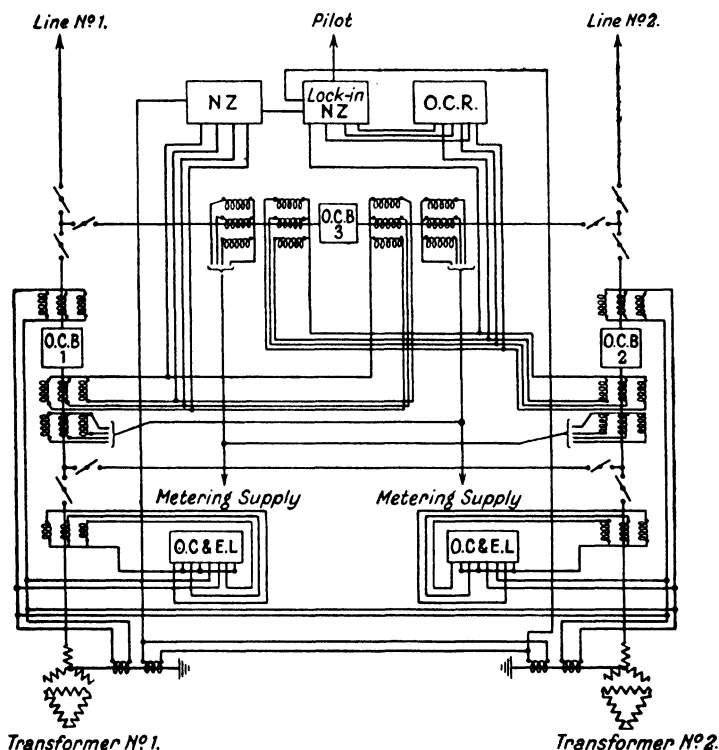

FIG. 228. SCHEMATIC DIAGRAM OF PROTECTIVE SCHEME APPLIED TO GRID THREE-SWITCH STATION

The impedance and lock-in relays do not directly close the trip circuits of their respective oil circuit-breakers, but energize tripping relays. The latter are fitted with multiple tripping contacts such that, when this relay is energized by either the impedance or lock-in relay, these contacts close the auxiliary supply on to the various circuit-breaker trip coils.

The voltage coils of the impedance and lock-in relays are energized from a voltage transformer connected on the l.v.

side of the power transformer. As it is necessary that correct vector relationship shall be maintained between the current and voltage elements of these protective relays, and also that the voltage on the relay shall be in strict proportion to the actual line voltage compensating current transformers must be incorporated with the power transformers to maintain the required relationship and proportion. Suitable cross connections are made through auxiliary switches on the oil circuit-breakers to ensure that, whether either one or both of the power transformers are in action, there will be a correct voltage supply to the relay elements.

The "Mesh" Type Station. An example of this type of Grid station is shown diagrammatically in Fig. 229. From this it will be seen that there are two step-up transformers and three outgoing feeders F_1 , F_2 and F_3 , all connected on the "mesh" principle. The type of protection applied in the example chosen is definite impedance and impedance/time, with over-current relays as back-up, and there is a set of relays to give this protection to each of the outgoing feeders.

The flexibility of this type of station lay-out has already been explained in Chapter II. It remains here to say something as to the way the full measure of protection is maintained for any and every one of the different switching arrangements that can occur. To do this it is necessary to consider each feeder line separately; although it might first be noted that each set of current transformers attached to each oil circuit-breaker is in parallel with another set. Thus, the current transformers associated with the oil circuit-breaker No. 1 are in parallel with those on oil circuit-breaker No. 5; whilst those on oil circuit-breaker No. 2 are in parallel with No. 3, and so on. The current transformers connected in "core balance" for earth leakage protection are paralleled somewhat differently, i.e. those with oil circuit-breaker No. 1 are in parallel with those with oil circuit-breaker No. 2, etc. The function of these will be explained later.

Consider now the feeder line F_1 . The supply from the power transformers to this feeder must traverse either bus-bar No. 1 or bus-bar No. 2 of the mesh, or it may travel by way of both. In any case, current will pass through the current transformers attached to either oil circuit-breaker Nos. 1 or 5, or through both. As the secondaries of these groups of current transformers are in parallel, it is immaterial which bus-bar supplies the

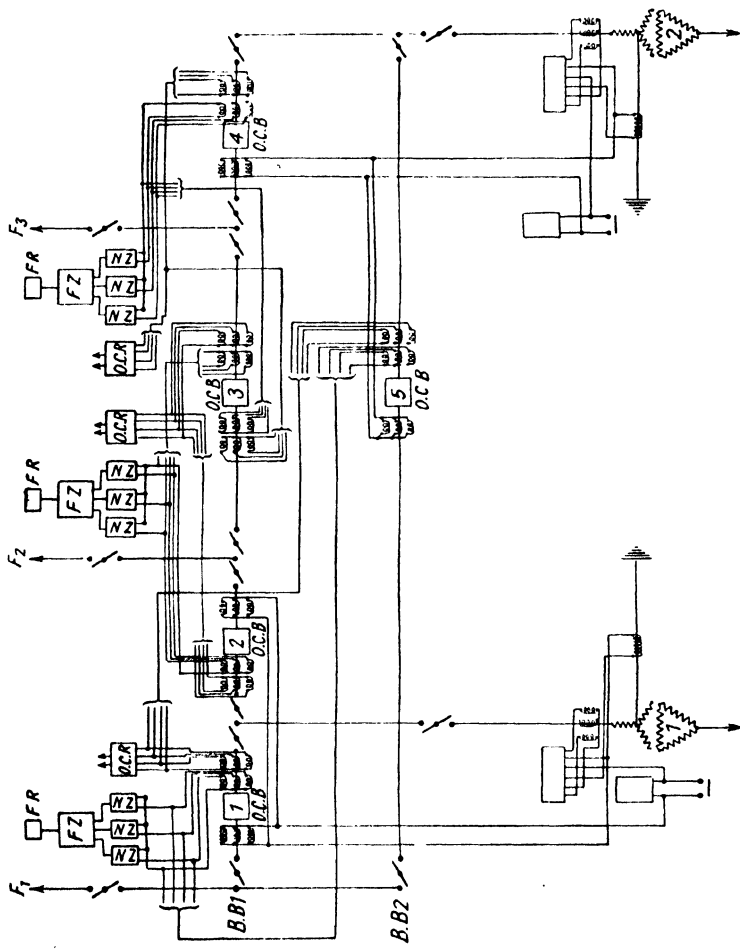

FIG. 229. SINGLE-LINE DIAGRAM FOR "MESH" TYPE STATION PROTECTIVE SCHEME

line F_1 , since one or the other set of current transformers will be energized to operate the protective relays controlling that line.

In the case of the line F_2 the supply to this must pass along either bus-bar No. 1 and oil circuit-breaker No. 2, or along bus-bar No. 1 and oil circuit-breaker No. 3; or, of course, it may pass along both of these. This ensures that the current transformers associated with either or both of these oil circuit-breakers will be energized; and again, because the secondaries of these are in parallel, a supply to the relays for this line is maintained, irrespective of whether the oil circuit-breaker No. 2 or No. 3 is open.

The same reasoning holds for the protection of the line F_3 and the oil circuit-breakers Nos. 3 and 4.

The arrangement of the relays in each of these sets for the line protection is interesting. There is a set of three single-phase type "NZ" directional impedance/time relays normally connected for phase fault protection. In conjunction with these there is a three-pole type "FZ" definite impedance relay which is practically instantaneous in operation and is for earth faults. There is also a type "FR" transfer relay. The two former are energized by the same double set of current transformers in parallel; the function of the "FR" relay will be given later. A three-pole overcurrent relay, operated by a separate set of double current transformers in parallel, provides back-up protection for phase faults.

The voltage supply to the directional elements of the "NZ" relays is given directly from the secondary of a three-phase voltage transformer, but the voltage supply for the restraint coils of these relays, whilst coming from the same source, is first passed through a set of two resistance boxes which are nominally for the purpose of obtaining voltage adjustment on the restraint coils (see Fig. 230). The directional voltage coils of the "NZ" relay are connected in delta across the voltage transformer, and thus measure line-to-line volts. The restraint coils of this relay are normally also connected in delta across the same source; but, in series with them, one on either side of each coil, are the two resistance units mentioned above. Thus the voltage across these coils is also proportional to line-to-line volts. This is as is required for phase fault protection. In addition, however, there is a connection taken from a point between the restraint coils and one of the resistance units

of each of the three elements, and these connections are coupled to the three contacts on one side of the "FR" transfer relay. The three contacts on the other side of the transfer relay

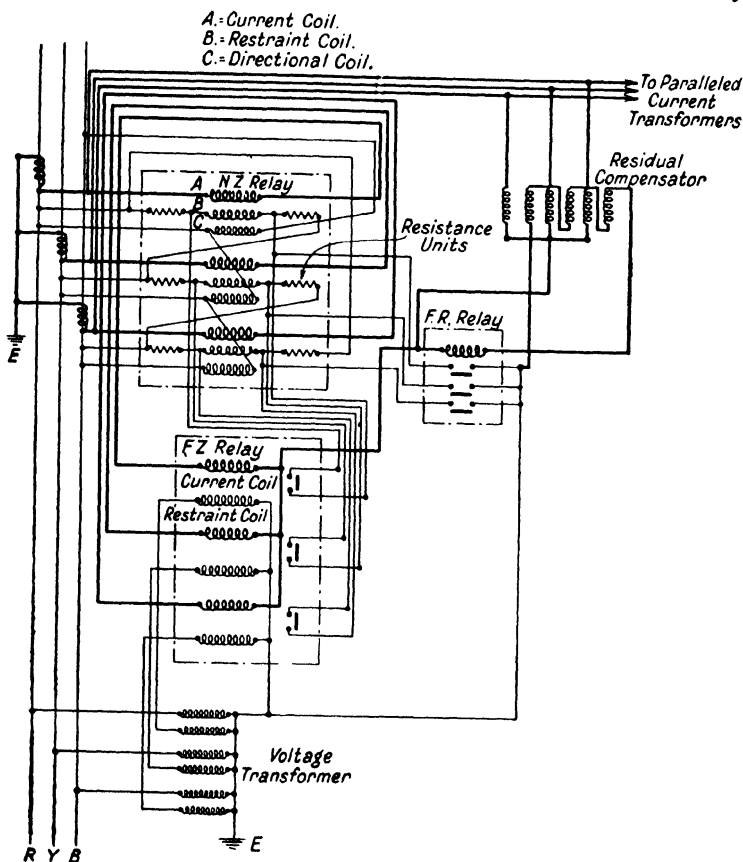

FIG. 230. RELAY COMBINATION USED IN "MESH" TYPE STATIONS FOR PHASE AND EARTH FAULT PROTECTION

Current connections shown in thick lines. Voltage connections in thin lines.

are connected together, and a common connection is taken from them to the neutral point of the voltage transformer. Therefore, when the transfer relay operates, the closing of its contacts converts the connections of the restraint coils of the "NZ" relay from the delta to the star formation across the

voltage transformer. Thus the voltage across these coils is now representative of phase-to-neutral volts, as is required for earth fault protection. The reason for this arrangement will best be understood by considering the protection as a whole.

The characteristic diagram for this is shown in Fig. 219. As already explained, the "NZ" relays normally operate on phase faults, and for a given section their operating curve will be O_1P_1 as shown in the figure. They are effective for 100 per cent of the length of their own section, and act as back-up protection for the next section. This is exhibited by the characteristic curves O_1P_1 and O_2P_2 for the relays covering sections 1 and 2 respectively.

The characteristic of the "FZ" relay is given by O_1Q_1 and is effective for 75 per cent of the length of the line section. It operates instantaneously on earth faults.

The "FR" or *transfer* relay is a sensitive earth-fault relay also instantaneous in operation. From the diagram in Fig. 230 it will be seen that it is connected in series with the secondary of a transformer, known as a *residual compensator*, across the current transformer neutral, and the common star point of the impedance relay coils and the primary of this residual compensator. Under healthy conditions there will be no residual current in either the relay coil system or the primary of the residual compensator, and therefore none through the "FR" relay. With earth fault conditions there will be residual current from both the impedance relay coil system and the primary of the residual compensator. This leakage current is magnified by the compensator.

Therefore, for earth faults, the "FR" relay will operate and convert the voltage connections of the "NZ" from the delta to the star formation as described above. In consequence the "NZ" will operate after the appropriate time delay and trip out the associated oil circuit-breaker.

Restricted Earth Fault Protection. In addition to the earth fault protection described above, which is mainly for feeder lines, there is a system of earth fault protection for station bus-bars, etc. The sphere of application of this is confined to faults within the station area, from which feature is derived the designation "restricted earth fault" protection.

If reference is made to Fig. 229 it will be observed that, on the line side of each of oil circuit-breakers Nos. 1 and 2, there is a set of three current transformers. Each set is connected

in core balance, and the two sets are connected in parallel with each other and with a single current transformer that is in the star point lead on the h.t. side of the power transformer. These current transformers feed a relay which has overcurrent and directional features. The connections are arranged so that the e.m.f. generated in the single transformer in the starpoint lead is in opposition to that generated in the other two sets of current transformers for any earth fault that may occur on the outgoing lines: whilst for faults that occur within the area between the current transformers these e.m.f.'s are in concurrence. Furthermore, the ratios of the various transformers are chosen such that the value of the secondaries of the bus-bar transformers is higher than that of the star point transformer; for example, the bus-bar current transformers may have a ratio 100/5 and the star point current transformer a ratio 400/4.5. Thus, for faults on the lines, the facts of the current transformer secondary e.m.f.'s being in opposition and the ratio of the bus-bar transformers being the higher, there will result a current from the bus-bar transformers through the directional element of the relay that will tend to rotate the disc against its stop; or, for this condition, the relay will be inoperative. For faults within the area between the relays, or *protected area* as it is called, the e.m.f.'s of the bus-bar current transformers will concur with that of the star-point transformer, and the resultant current will flow through the relay coils in a direction opposite to that for the former case. Thus the relay will operate to open oil circuit-breakers Nos. 1 and 2 and isolate the fault. A similar arrangement of transformers and relay is attached to the second power transformer and oil circuit-breakers Nos. 4 and 5. There are many incidental features and attachments to the protection of this type of station, but as these may vary considerably, it is not thought worth while to go into all these details.

Parallel Feeder Protection. This system of protection, as the name implies, is for use with lines that are run in parallel. The basis of operation is the fact that, normally, both lines of a duplicate system will share the load equally. If from any cause, such as a fault on one line, the balance should be disturbed, then the relays must be sensitive to the difference between the currents in the two lines, and operate when that difference exceeds a certain magnitude. It is from this feature that the relay derives the name "differential," and when such

a relay is also fitted with a directional element, the "differential directional" relay results. The Metropolitan-Vickers type "ND" relay provides a good example of the modern differential directional relay, and its action may be described briefly as follows.

It is a non-pilot wire relay, and is made up of two elements—a differentially wound current element, and a directional element. Both of these elements are of the standard induction

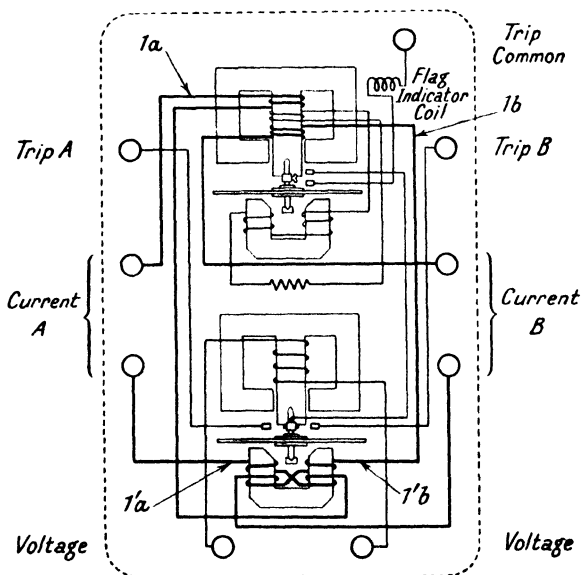

FIG. 231. INTERNAL CONNECTIONS OF TYPE "ND" RELAY

type, acting on a disc. The differential current element comprises, in effect, a small transformer, with two primary windings *1a* and *1b*, acting in opposition. These primary windings are in series with the opposed windings of the operating magnet of the directional element (see Fig. 231). The secondary winding of the current element energizes also the lower magnet of this element. One primary winding of the current element is energized by a current transformer in one of the parallel feeder lines, and the other by a current transformer in the other feeder line. It will thus be understood that when equal currents are flowing in the parallel feeders, equal currents will flow in the

two primary windings of the relay current element, and as these are in opposition, no resultant torque on the relay disc will ensue. As out-of-balance current increases between the feeder lines for any reason, so will an increasing torque be put on the relay disc, until operation takes place. It must also be observed that, should the current change direction in one of the feeder lines, there will result the condition of the current in the two coils $1a$ and $1b$ being in concurrence instead of in opposition. The out-of-balance current operating the relay, will, in this case, be represented by the algebraical sum of the currents in each of the separate feeders. The rotation of the disc of this element is always in the same direction, since whichever line current predominates, the flux in the lower magnet results from that in the upper magnet, and the same relationship is therefore always maintained.

The directional element is made up of two parts, a voltage winding energizing a polarizing magnet, and two current windings in opposition on a lower magnet. These current windings $1'a$ and $1'b$ are those in series with $1a$ and $1b$ described above. There are double contacts in this element, such that whichever current winding produces the larger flux to react with the flux from the voltage winding, the disc will rotate in the associated direction to close the corresponding contacts. It will be seen that there are three trip-circuit terminals. One is common and is in series with the flag indicator coil and trip contacts of the differential element, whilst the other two connect to the trip contacts of the directional element, as shown in the figure. The relay therefore cannot operate to trip a circuit-breaker until both elements have functioned. Thus the required out-of-balance or differential and directional features are obtained.

A somewhat similar differential directional relay, Metropolitan-Vickers type "NFD," is shown diagrammatically in Fig. 232. In this, the differential element has one coil only, and this is fitted with a number of tapping points so that connection can be made from the line current transformer through either the whole of this current winding or only some portion of it. The differential feature is obtained by cross connecting the two sets of current transformers on the parallel feeder lines, and this has the effect that only the algebraical sum of the two line currents will flow through the relay coil. The directional element of this relay is practically the same as for the relay described above.

As examples of the application of the two kinds of parallel line protection to high voltage schemes, an explanation is given below of the protection applied to a 66 kV. hydro-electric system in Malaya, and to a somewhat similar system in Egypt.

The system in Malaya adopted the first type of parallel line protection described above. A section of the scheme is

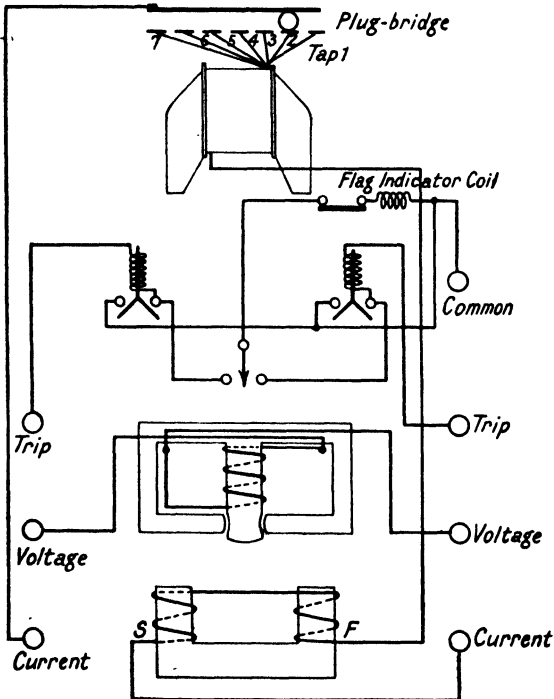

FIG. 232. INTERNAL CONNECTIONS OF DIFFERENTIAL DIRECTIONAL RELAY, "NFD" TYPE

shown in Fig. 233, and in Fig. 234 are shown the connections for the differential directional relays. Stations A and D (Fig. 233) are supply points, whilst B and C are sub-stations. There are two sets of current transformers at each station, and of these one set is connected in core balance to operate the differential earth leakage relay; whilst the other set is connected to operate the phase fault differential relays. The second set of current transformers also operates a back-up inverse-time relay connected for overcurrent and earth leakage.

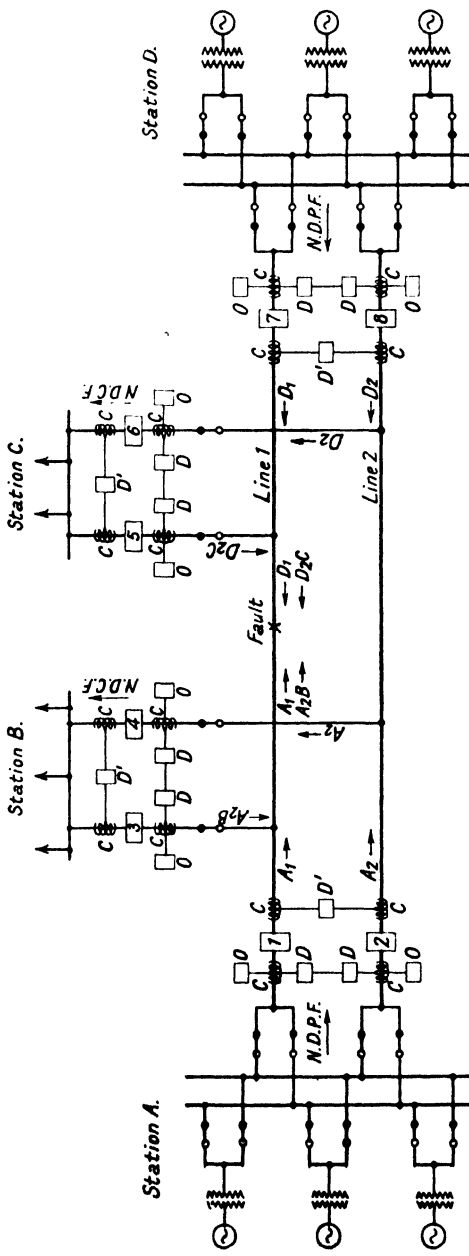

FIG. 233. APPLICATION OF DIFFERENTIAL DIRECTIONAL PROTECTION TO A 66 KV. PARALLEL LINE SYSTEM

- 1-2, etc. = Oil circuit-breakers.
- C = Current transformers.
- D = Differential directional phase fault relays.
- D' = Differential directional earth fault relays.
- O = Overcurrent relays.
- N.D.P.F. = Normal direction of power flow.

Consider a fault on line No. 1 at the point indicated in Fig. 233, and suppose all stations connected to the duplicate lines. The fault will be fed from stations *A* and *D* along line No. 1, as indicated by the arrows *A1*, *D1*. It will also be fed from stations *A* and *D* by way of line No. 2, and the bus-bars of sub-stations *B* and *C*, as indicated by the arrows *A2B*, *D2C*. The actual distribution of current from stations *A* and *B*, through the bars of stations *B* and *C*, will depend upon the

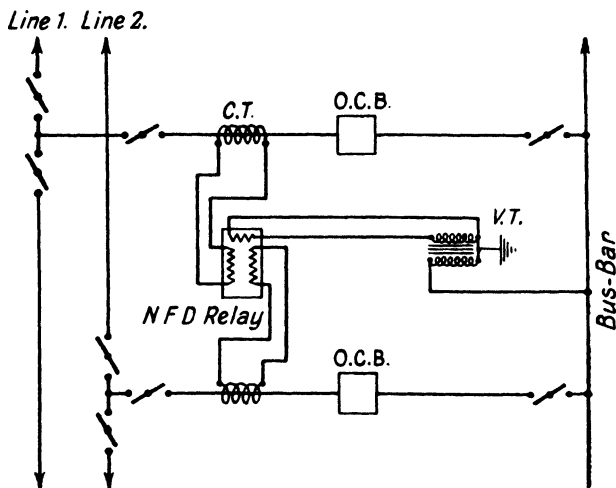

FIG. 234. SINGLE LINE DIAGRAM SHOWING METHOD OF CONNECTING TYPE "NFD" DIFFERENTIAL DIRECTIONAL RELAY

relative capacities of stations *A* and *D*, and upon the relative line impedances between the various stations.

For the distribution shown, the differential relays at stations *B* and *C* will operate to open breakers 3 and 5, thus removing these two stations from the faulty line. After a suitable time discrimination, the differential relays at stations *A* and *D* will operate to open breakers 1 and 7. Thus will the faulty section be entirely isolated without any loss of load to the system.

The system in Egypt includes a number of outdoor stations, from each of which continuity of supply is considered a necessity. All lines are in duplicate, and, logically, differential directional protection was suggested. The type chosen was the second of the two kinds described above.

A section of this system is shown in Fig. 235, and in Fig. 236 are given the connections for the "NFD" relays. Two generating stations are considered (Fig. 235), designated *A* and *D*, and two sub-stations *B* and *C*. Suppose the fault to be on line No. 1 at the point indicated. As in the Malayan system, the fault will be fed from stations *A* and *D* along line No. 1, as indicated by arrows *A1*, *D1*. It will also be fed from station *A* by way of line No. 2, and the bars of sub-stations *B* and *C*, as

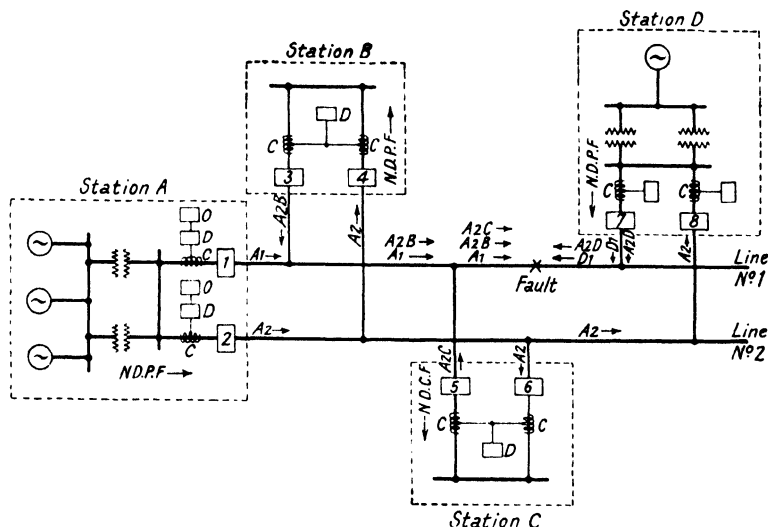

FIG. 235. APPLICATION OF DIFFERENTIAL DIRECTIONAL PROTECTION TO A 66 kV. PARALLEL LINE SYSTEM

1-2, etc. = Oil circuit-breakers.

C = Current transformers.

D = Differential directional relay.

O = Overcurrent relay.

N.D.P.F. = Normal direction of power flow.

indicated by arrows *A2B*, *A2C*, and, because station *D* is of much smaller capacity than station *A*, the latter can feed the fault along line No. 2, and the bars of station *D*. This is shown by arrow *A2D*.

At each of stations *B* and *C* there is a reversal in the direction of current in the line feeders from line No. 1, since the normal direction of current flow in these feeders is from the main line to the sub-station. This reversal will operate the "NFD" relays to open oil circuit-breakers Nos. 3 and 5, thus cutting off these two stations from the faulty line. There is also a reversal of current in the feeder from line No. 2 to station *D*,

382 OUTDOOR HIGH VOLTAGE SWITCHGEAR

since the latter normally supplies current to the main line. This reversal operates the directional relays at this station to open breaker No. 7. The fault is now fed only by station A along line No. 1. Out-of-balance in the differential relays at this station will make the relays operate to open breaker No. 1 and thus completely isolate the faulty section.

When working out the time settings for the various relays on a protective scheme, it is essential to take into consideration the time of operation required by the tripping of the affected

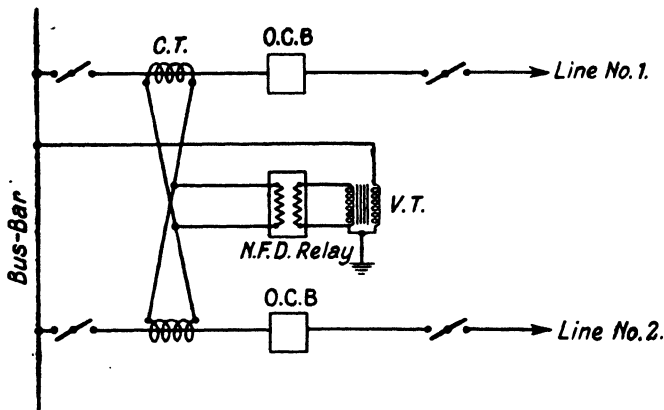

FIG. 236. SINGLE LINE DIAGRAM SHOWING METHOD OF CONNECTING A SINGLE ELEMENT TYPE "NFD" DIFFERENTIAL DIRECTIONAL RELAY

oil circuit-breakers. In general, half a second can be taken to represent the time required for this purpose; although in a case of time setting discrimination involving a large number of circuit-breakers, the exact tripping time should be obtained from the breaker manufacturer.

BUSHING TYPE CURRENT TRANSFORMERS

In high voltage practice the operation of protective relays is often obtained with the use of the bushing-type current transformer. This is mainly because such a transformer is economical in cost and space, since it can be accommodated very conveniently on the high voltage bushings of the oil-circuit breakers or power transformers. There is, however, sometimes a tendency to expect too much of it, and to overlook the fact that it is a bar-primary transformer of a rather special nature.

There is no doubt that the bushing-type current transformer,

although admirable and entirely satisfactory for many purposes, is very limited in its capacity. It is to be remembered that not only has it a single turn primary, but the core has necessarily a comparatively long mean magnetic path. This, of course, is due to the fact that it has to slip over the diameter of the high voltage bushing, and as such bushings are of appreciable diameter, this feature becomes very pronounced in the higher voltage range.

In order to obtain some idea of the capabilities of bushing

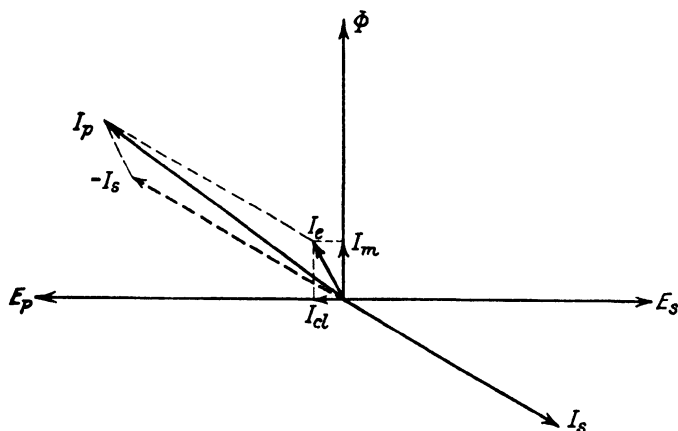

FIG. 237. TYPICAL VECTOR DIAGRAM OF BUSHING TYPE CURRENT TRANSFORMERS

- | | |
|--------------------------------------|-------------------------------|
| E_p = Primary voltage. | E_s = Secondary voltage. |
| I_p = Primary current. | I_s = Secondary current. |
| $-I_s$ = Secondary current reversed. | Φ = Flux. |
| I_m = Magnetizing current. | I_{cl} = Core loss current. |
| I_e = Excitation current. | |

transformers, it is requisite that they be treated in some detail. At the outset it should be realized that the performance of the transformer depends only on the core section, the length of mean magnetic path, and the quality of the iron used. Again, the primary current must provide, not only the ampere-turns for the secondary load, but also the ampere-turns for magnetizing the core. With very small primary currents, and the higher voltages are generally accompanied by such small currents, the major portion of the primary current may be absorbed for core magnetization, with very little surplus for the secondary output.

Consider now Fig. 237, which shows the vector diagram for

an example transformer. This may be analysed as follows. For a given secondary output current, I_s in the figure, the primary has to provide a magnetizing current that will create in the core the necessary flux for this purpose. This current is in phase with the flux. In addition, the primary has to provide current to overcome core losses, and this current will

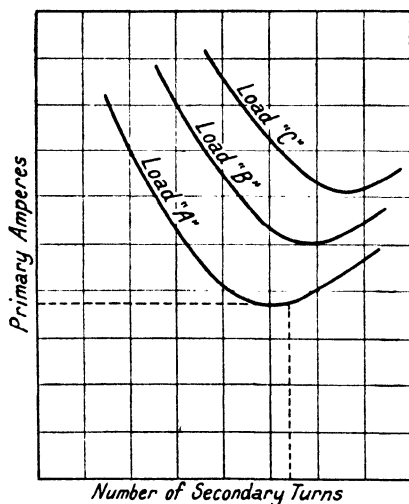

FIG. 238. CHARACTERISTIC CURVES OF BUSHING TYPE CURRENT TRANSFORMERS AT VARIOUS SECONDARY BURDENS

be in phase with the primary voltage. The vectorial sum of these two currents represents the excitation current of the transformer and is shown by the vector I_e in the figure. Therefore, the total primary current necessary for this secondary output I_s becomes I_p , which is the vectorial sum of I_e and I_s . The difference in phase between the primary and secondary currents will be exactly 180° only when the power factor of the total secondary burden is equal to the power factor of the excitation current.

The total secondary burden is the internal burden of the transformer plus the external load burden.

If the number of secondary turns be plotted against primary current for a bushing type transformer with a given secondary burden, a curve will result something of the shape of those shown in Fig. 238, and, furthermore, there will be a similar curve for each different burden. The characteristic exhibited is that, for a given burden, there is a definite number of secondary turns that corresponds with the minimum primary current. Any departure from this critical number of secondary turns results in an increase in primary current. This feature demonstrates the necessity of allowing the manufacturer a free hand in designing the transformer for a specific purpose, since the ideal turns ratio may be quite different from the nominal current ratio.

Multicore Cable Schemes. Where the pieces of apparatus that require connection to the control board are few, it is usual to run the multicores direct from each piece to the control or relay board. A stage is reached, however, when such an arrangement becomes uneconomical, especially where the control and relay boards are some distance from the outdoor station. A more economical lay-out can then be obtained by combining the leads between the control board and outdoor station site into one or more large multicore cables. One of these cables

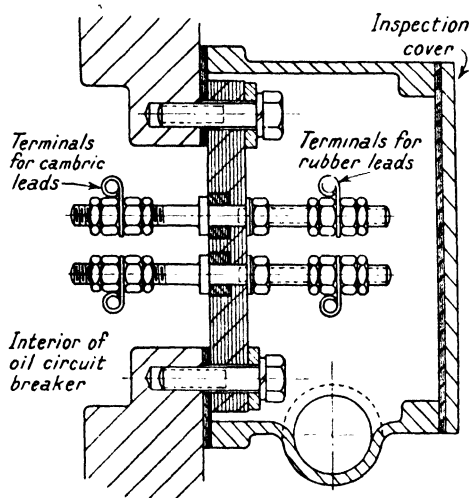

FIG. 240. TERMINAL BOARD FOR THE INTERCONNECTION BETWEEN A BUSHING TYPE CURRENT TRANSFORMER MOUNTED IN AN OIL CIRCUIT-BREAKER AND THE INTERCONNECTING CABLES

may contain as many as sixty cores. Each of these trunk multicores is brought to a convenient position on the outdoor site and terminated in a weatherproof cubicle. Smaller multicore cables are then used for bringing the leads from each piece of apparatus to the cubicle, where all interconnections are made on accessible terminal boards. This arrangement in many cases reduces cable laying costs in addition to the saving made on the cable itself.

The actual methods used for laying the cables vary according to their number and the type of ground in which they are to be laid. The most satisfactory scheme is to provide a system of concrete trenches so arranged that cables from the various

pieces of apparatus will have to run but a short distance in the ground before they meet a trench. The top of the trench or trough should be at ground level and be covered by a concrete slab. A cheaper scheme, which is used for small stations and where single cables are some distance from a trench, is to lay the cable direct in the ground. In such cases it is advisable to lay tiles or slabs immediately above the cable just below ground level. These covers aid the tracing of the cable run and prevent mechanical damage. The ground itself should be analysed for acid content, which, if present, should be notified to the cable makers. An economical method of arranging interconnecting cables on the high type of station is to run them along the steel structure members, to which they should be clamped. This method reduces excavation work to a minimum.

D.C. Cables for Solenoid Coils. The large currents taken by oil circuit-breaker closing solenoids provide a problem in cabling, as an excessive voltage drop between the battery and the coil must not occur. For this reason it is usual to install the battery on the station site in close proximity to the circuit-breakers. The most economical cable arrangement is usually obtained by installing a ring main which travels from breaker to breaker by the shortest possible route. Each coil is thereby fed by two cables. This scheme has the advantage common to all ring main schemes in that a faulty section of cable can be isolated without disconnecting any breaker. When calculating the voltage drop on any particular cable arrangement, the drop in the battery itself must not be neglected.

Terminal Boards and Auxiliary Switches. These items, which are directly connected with small wiring, do not always receive the consideration their importance demands. Incorrect operation has often been traced to a defective terminal board or auxiliary switch contact. Terminal spacing should be liberal, at least half an inch clearance between each, the terminal studs themselves being 0 B.A. or more. Auxiliary contacts should be larger than would appear essential for the currents to be carried, and should preferably have a wiping action. Easy access to terminals and auxiliary switch contacts is too often overlooked.

The following example will suffice to indicate the method to be adopted to determine the minimum size of cable required for the battery supply to an oil circuit-breaker closing coil.

Let the minimum operating power to close the breaker be found on test to be 104 A., at 81 V. across the coil terminals with the coil cold. From this, the coil cold resistance is 0.78 Ω. Let the internal resistance of the battery for a discharge current of 104 A. be 0.0004 Ω. per cell, and suppose the battery to consist of 60 cells. The B.S.I. Regulations, B.S.S. No. 116—1929, state that the breaker must close satisfactorily at 20 per cent below normal operating voltage and with the coil temperature up to 40° C. The temperature coefficient of resistance of copper is 0.00427. Therefore, if the cold resistance of the coil of 0.78 Ω. be supposed to be taken at an ambient temperature of 15° C., the resistance at 40° C. will be given by

$$R_{40} = 0.78 (1 + 0.00427 \times 25) = 0.87 \Omega.$$

Suppose the minimum cell open circuit e.m.f. to which it is permissible to discharge the battery is 1.9 V., then the minimum battery open circuit e.m.f. is $60 \times 1.9 = 114$ V.

The problem can now be stated thus—

Minimum current required through coil	104 A.
Resistance of circuit—	
Battery internal resistance 60×0.0004	0.024
Coil resistance at 40° C.	0.870
Cable resistance	x
Total resistance of circuit	$x + 0.894 \Omega.$
Minimum open circuit e.m.f. of battery	114 V.

From the above we have

$$104 = 114/(x + 0.894).$$

$$\text{Therefore } x = 0.202 \Omega.$$

If the cable route length be 100 yd., which is 200 yd. loop length, the resistance per yard of the cable required is $0.202/200 = 0.00101 \Omega.$ The nearest cable size to meet this value is 19/0.044 copper stranded conductor, which has a resistance of 0.8721 Ω. per 1 000 yd. or 0.0008721 Ω. per yd.

In the case of a ring main cable, care must be taken, when calculating the minimum cable size, to observe the fact that the maximum length of cable run will be that which occurs when, due to a fault, the ring is opened between the battery and the nearest oil circuit-breaker, and in consequence the feed has to be taken along the healthy arm of the ring to the most remote breaker.

CHAPTER XVI

METALCLAD SWITCHGEAR

UNTIL recent years, 33 000 volts was the limit of the voltage range for which metalclad switchgear was manufactured. This was no doubt due to the fact that this class of gear, being of British origin, was designed for the home market, and 33 000 volts was the highest voltage in general use in Britain at that time. With the advent of the Grid, conditions changed due to the extended voltage range, and metalclad switchgear is

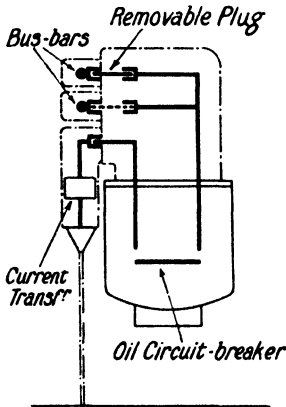

FIG. 241. HORIZONTAL DRAW-OUT ISOLATION USED FOR METAL-CLAD SWITCHGEAR

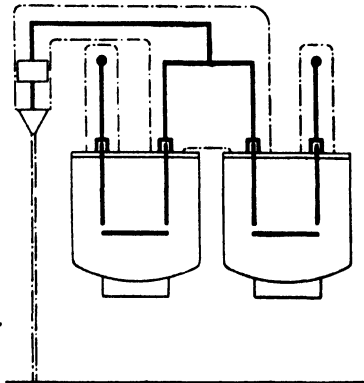

FIG. 242. VERTICAL DROP-DOWN ISOLATION USED FOR METAL-CLAD SWITCHGEAR

now manufactured for Grid lines up to 132 kV. It will also be appreciated that the development of metalclad switchgear is dependent upon the development of high-voltage cables. In countries abroad the use of metalclad gear was not regarded with much enthusiasm at first, but now the design is much more popular, and installations are to be found in most parts of the world.

There is no doubt that this class of gear is very successful where economy in space has to be effected, and it has made possible the most extensive switching arrangements in the most congested surroundings. Perhaps the best example of

this is that of the Battersea Power Station, which is situated in the heart of London and serves one of the most densely populated areas in the world. In such cases the saving in the cost of ground space and buildings will easily offset the greater cost of metalclad gear compared with that of the open type indoor switchgear.

All metalclad designs fall into one of four distinct groups, dependent upon the method used to isolate the oil circuit-breaker for inspection. These types are generally known as follows—

Horizontal drawout. (Fig. 241.)

Vertical drop-down. (Fig. 242.)

Vertical lift-up. (Fig. 244.)

Fixed oil circuit-breaker isolated by means of oil immersed isolating switches. (Fig. 250.)

The types illustrated in Figs. 241 and 242 have been used extensively for voltages up to and including 33 kV.

Where duplicate bus-bars are used, selection is effected in various ways. Thus with the horizontal drawout arrangement, oil selectors, which are mounted in a

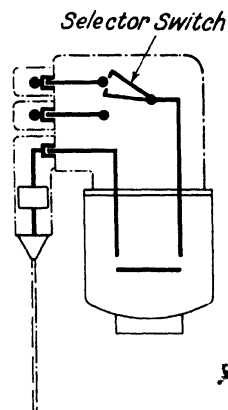

FIG. 243. ARRANGEMENT FOR OIL SELECTORS IN HORIZONTAL DRAW-OUT ARRANGEMENT

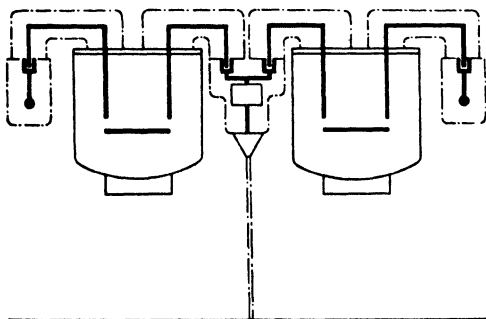

FIG. 244. VERTICAL LIFT-UP ISOLATION USED FOR METAL-CLAD SWITCHGEAR

chamber above the circuit-breaker (Fig. 243), may be used. An alternative arrangement utilizes removable plugs as in Fig. 241. The change-over with vertical drop-down isolation is effected by lowering the circuit-breaker and transferring it across to

the second set of bus-bars, and again raising it to the service position (Fig. 242). The vertical lift-up scheme is similar to the vertical drop-down, except that the circuit-breaker is raised instead of lowered (Fig. 244). This latter scheme is used in the 66 kV. switchgear for Battersea. In this case two circuit-breakers per circuit are used owing to the importance of the station; a single circuit-breaker per circuit with one spare circuit-breaker would in some stations give sufficient flexibility.

As all live parts are shrouded in earthed metal containers, it is necessary to make arrangements for voltage testing the switchgear and cables. This is usually accomplished by providing a socket contact at the points chosen for the attachment of testing connections. An aperture in the earthed metal container immediately above the socket is then necessary to enable a testing bushing to be inserted. This aperture is normally closed by means of a locked cover. Such an arrangement is shown in Figs. 245 and 246.

The use of compound and oil instead of air as the insulation medium in metalclad gear, and the absence of all exposed live parts, make the safety clearances given in Chapter II inapplicable to this class of switchgear. Indeed, the question of clearance only arises in regard to passage ways between units, and these must be of such a size that efficient operation and maintenance are possible.

Up to 33 kV. the established design changes but little, differences being mainly a matter of increase of dimensions as the voltage increases, but at 66 kV. and above, the dielectric problems become more difficult, and these, together with the large internal clearances necessary and the greater weight and bulk of apparatus, tend to direct design along different lines. For instance, at 66 000 volts the distance the circuit-breaker has to be moved away from the bus structure for isolation purposes is quite large when considered in conjunction with the weight and bulk of the breaker, particularly when the latter is of large rupturing capacity. And, again, the design of the isolating plug and socket contacts between the circuit-breaker and stationary connections presents rather more difficulty.

At voltages not exceeding 33 kV. air insulated isolating plug and socket contacts are generally used. Above 33 kV. the difficulty in designing isolating plugs which do not overstress the surrounding air has led to the adoption of designs which provide for the oil immersion of all bare connections, etc.

Metalclad gear for 66 kV. and above is usually designed so that it can be made suitable for outdoor mounting if so desired.

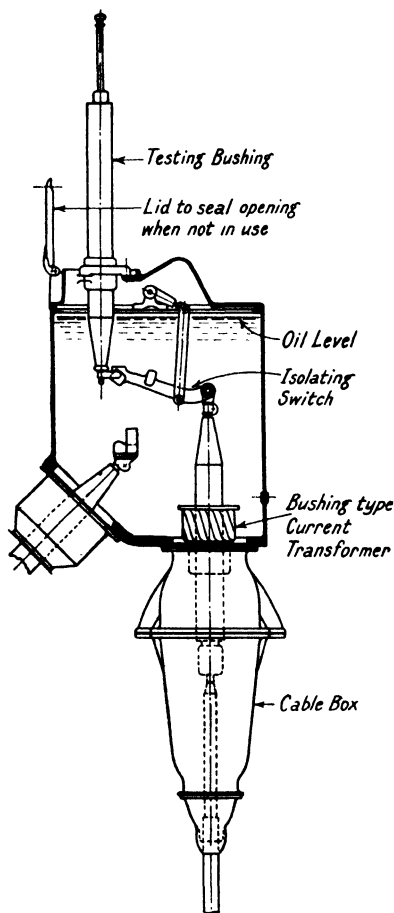

FIG. 245. TESTING BUSHING ARRANGED TO TRANSMIT TEST VOLTAGE TO A CABLE

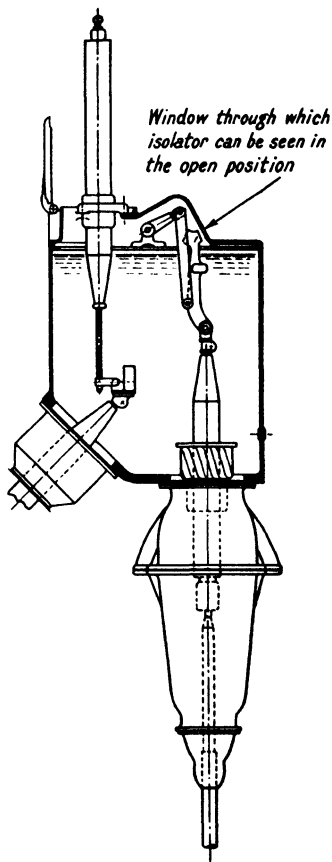

FIG. 246. AN ALTERNATIVE POSITION OF THE TESTING BUSHING IN FIG. 245 ARRANGED IN THIS CASE FOR SWITCHGEAR TEST

Metropolitan-Vickers Type K10 Metalclad Gear. This type of metalclad switchgear contains a number of original and ingenious solutions to some of the special difficulties attached to such gear for 66 000 volt service. Thus the amount of oil

has been reduced to a minimum, and compound has been avoided entirely. If compound were used as the dielectric for this service voltage a considerable amount would be needed to give the required thickness of insulation between line conductor and earthed metal, and it is found in practice to be very difficult to obtain a homogeneous filling with a large quantity of a semi-fluid compound. More unfortunate still is the fact that it is next to impossible to determine whether the filling is really homogeneous or not. It is for this reason that compound as a dielectric was avoided in this design of gear, and the substitute—oil—adopted. Oil has the disadvantage of being inflammable and quick to leak; therefore, the design arranged that the quantity of oil used should be reduced to the smallest possible. With this end in view, the K10 gear was designed to include a number of separate chambers, each oil-filled, but with no oil communication between them. Thus, apart from the oil circuit-breaker itself, there is a separate oil chamber for each of the terminals of the breaker contacts, and from this chamber is brought out the connection for the isolating plug. The corresponding isolating sockets are each in their own separate chambers, which are mounted on the bedplate of the equipment, and from which connections are taken to the bus-bars, etc. The conductors that pass from the breaker to the oil chambers, and from one oil chamber to another, are all insulated in the manner of condenser bushings, by which is meant that the electrical stress is graded between the conductors and the earthed metal of the chambers, and also over the surface of the bushing ends under the oil.

The same principle is applied to the bus-bars themselves, in that each bus-bar is a long condenser bushing with each of its ends terminating in an oil-filled chamber. It will thus be seen that all bus-bars and associated connections are insulated without oil or compound, except the ends and tee joints which are insulated in their separate oil chambers. This means that should an oil leak occur it will be confined to its own chamber.

In the case of the Battersea Power Station, the circuit-breakers and bus-bars are situated on different floors. The sectional view of this station, Fig. 247, shows this quite clearly, whilst Fig. 248 shows the type K10 metalclad oil circuit-breaker. The latter consists of a fabricated steel plate structure, or soleplate, on which are fixed four square section guideposts. The main frame of the oil circuit-breaker has a square hole at

each corner, through which it is kept in a proper relationship to the soleplate by the guide posts. For isolating purposes the breaker is raised as a whole by means of a travelling crane. When it is at the correct height, the square holes in the breaker

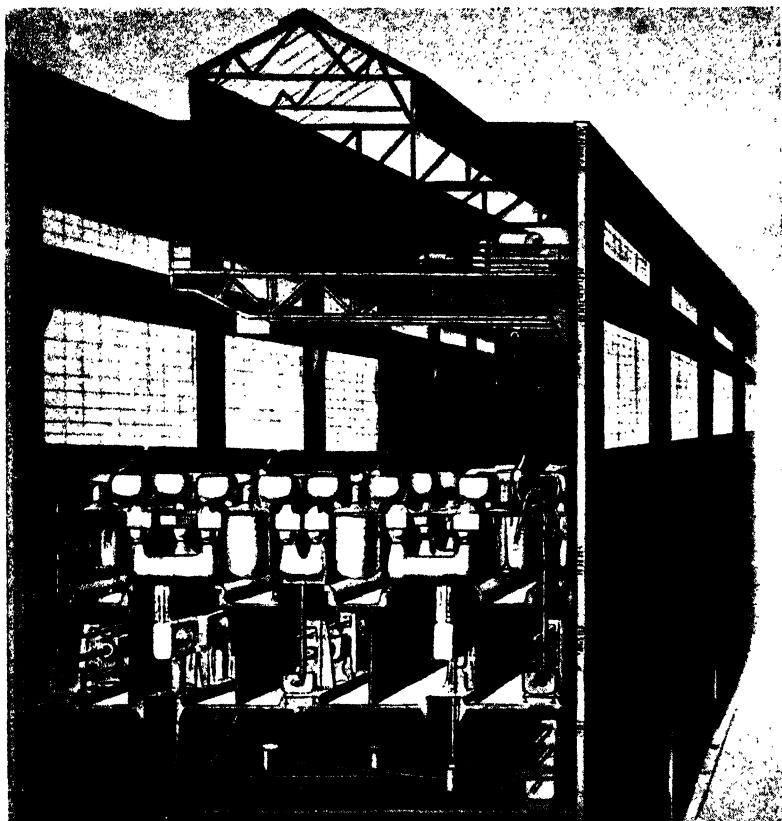

FIG. 247. SECTIONAL VIEW OF 66 kV. METAL-CLAD SWITCHGEAR AT BATTERSEA POWER STATION
(Metropolitan Vickers Elec. Co.)

frame have traversed beyond the square portion of the guide posts, and in this position the guide posts can be rotated 45° , and the breaker unit lowered to rest on the support provided by the misalignment that now exists between the square posts and square holes. When the breaker is raised to this position the isolating plugs are withdrawn from their sockets in the

fixed chambers below. The socket in this chamber is well below the oil level, so that when the plug is removed no live metal is exposed to the atmosphere. To prevent dirt entering the oil pots, a patent automatic self-sealing shutter is fitted.

Each phase of the circuit-breaker is a separate assembly in its own cylindrical oil tank, and the three are fastened to the main supporting frame to form a three-phase unit. The closing and tripping mechanism is contained in a separate chamber mounted above the centre phase of the breaker, as can clearly be seen in Fig. 248. This closing mechanism is the usual solenoid acting through toggle links, and embodies a free-handle feature over the whole of its closing stroke. The opening speed is high, obtained by means of powerful accelerating springs, and oil dashpots come into action towards the end of the stroke to absorb shock.

The type of contacts used is purely a question of the purpose to be assigned to the breaker and of the ideas of the designer. What is given elsewhere in this book on the design of contacts applies to metalclad gear as well as to outdoor type oil circuit-breakers. The tanks of the circuit-breaker of the type K10 metalclad gear are cylindrical in shape, and made of welded boiler plate with a domed base and seating. This is the best shape to withstand high internal pressures most efficiently. Each tank is designed to withstand a hydraulic test pressure of 500 lb. per sq. in.

The bus-bars, as already explained, are specially designed condenser bushings with their ends terminating in separate oil chambers. The earth band of the bushing is provided by a sheathing of copper sheet over which is wound a layer of tinned copper wire. This makes a strong mechanical armouring as well as an earth band, and being earthed and bonded at suitable intervals ensures electrical stability. Furthermore, each set of three-phase bus-bars is mounted in its own compartment, which is entirely separated by fireproof walls from the remainder of the apparatus. This minimizes the risk of fire, and enables individual lengths of bus-bar to be isolated and oil chambers to be inspected. Fig. 249 shows a set of these bus-bars.

Each piece of ancillary apparatus, such as current transformers and voltage transformers, is mounted in its own oil filled chamber. All these various oil sealing chambers are provided with a large head of oil, and the filling level can easily and safely be checked by means of a dipstick while the

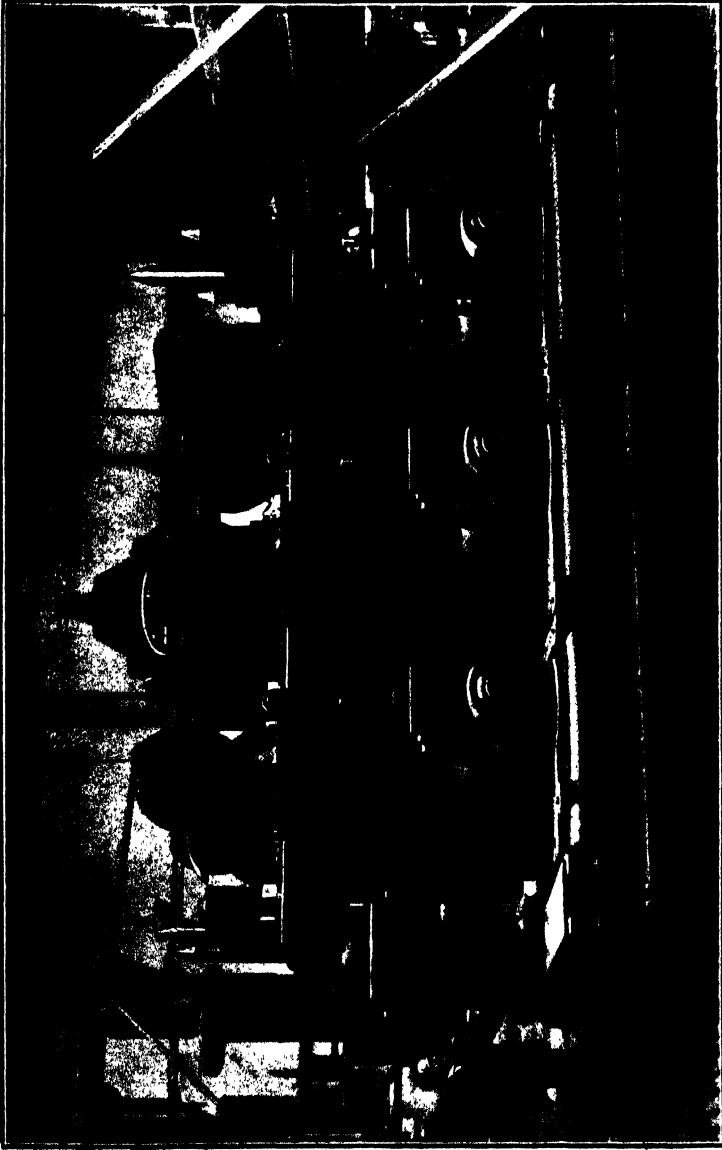

FIG. 248. METROPOLITAN-VICKERS TYPE "K10" 66 kV. METALCLAD OIL CIRCUIT-BREAKER,
FOR BATTERSEA POWER STATION
(Metropolitan-Vickers Elec. Co.)

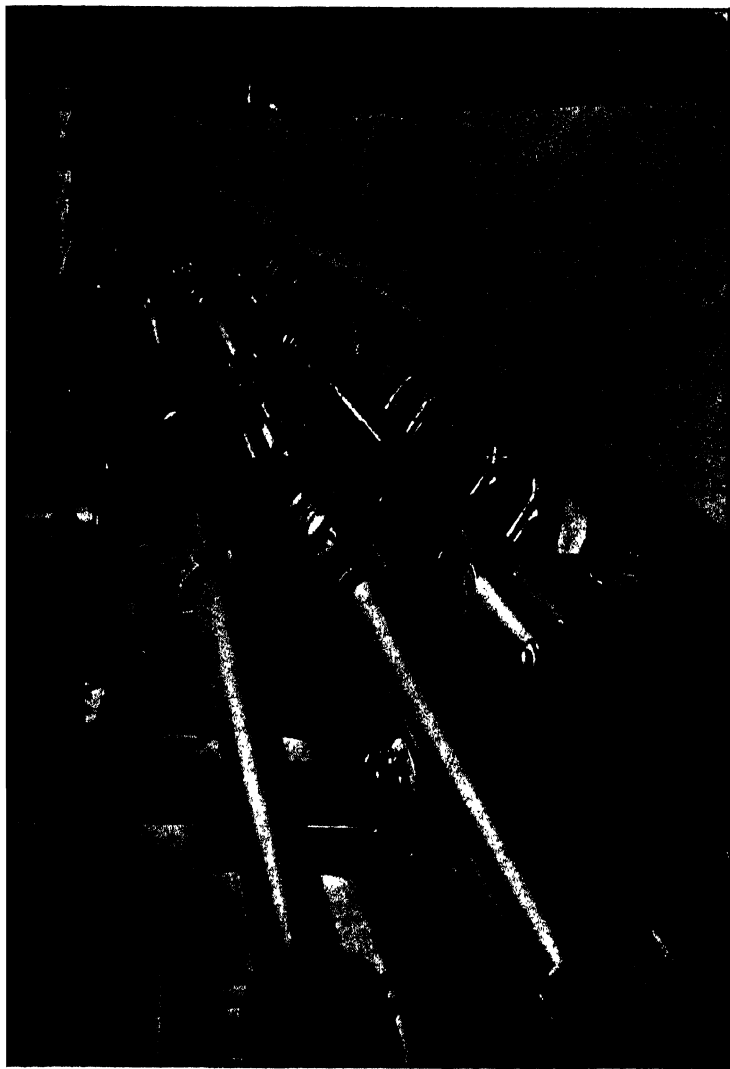

FIG. 249. BUS-BARS ON FLOOR BENEATH OIL CIRCUIT-BREAKERS
BATTERSEA POWER STATION
(Metropolitan-Vickers Elec. Co.)

Impulse Type Oil Circuit-Breaker. The principal features of this circuit-breaker are—

- (1) Its rapid arc extinguishing properties.
- (2) A consistent performance at all current values up to its maximum rating.
- (3) The economical use of oil.

All the oil circuit-breaker devices described in this Chapter depend for their efficiency upon the power generated by the arc itself. This power varies in accordance with the energy interrupted. Actual tests have proved that despite this variation a well-designed breaker can be depended upon to break currents up to its rating without undue damage to itself. The arcing time for a particular condition cannot, however, be estimated within several half-cycles. This fact will in many cases be of secondary importance, but where large stations are interconnected, delay in fault clearance may mean that synchronous machinery will be thrown out of step.

The design of the impulse circuit-breaker is such that the variation and duration of arcing times are considerably reduced when compared with a conventional circuit-breaker. When considering the problem of arc extinction, it would appear logical to expect that, provided the necessary oil velocity could be obtained, the arc products, existing between two contacts at a current zero, could be swept away and replaced by oil of such a thickness that the re-establishment of the arc would be prevented. To attain such an arrangement two requirements are at once apparent. Some means are necessary to produce a dependable oil supply at the necessary velocity, and secondly, the required velocity for any particular case must be known. The first requirement can be met by an arrangement whereby the oil velocity at the contacts is entirely independent of the arc itself and is of a known value. The second requirement can be obtained by tests and calculation.

Tests on an experimental single-phase breaker, built to fulfil the requirements enumerated, have been described by Prince and Poitras. The breaker has a single break of $1\frac{1}{4}$ in. and is shown diagrammatically in Fig. 258. The oil supply to the jet is provided by a spring-loaded piston, which is released when the breaker is tripped; thus a known oil velocity is obtained. A small break was chosen because it was thought that uniformity of oil flow would be better maintained in a small gap. Furthermore, the energy required to propel the oil through the

gap at a given velocity would be less than that required for a larger break; also, movement of the contact would have ceased at the time of current zero. The interruption period is indicated in Fig. 258. It is assumed that the arc products, at the instant of current zero, have a cone-shaped boundary surface a, a . In a time dt this surface will be displaced to a_1a_1 ; thus giving an oil thickness of $d\phi$ between the contacts to act as insulation against the rising potential.

Some 400 tests were made on this breaker at voltages and currents ranging from 3 800 to 13 200 volts and 6 600 to 23 000

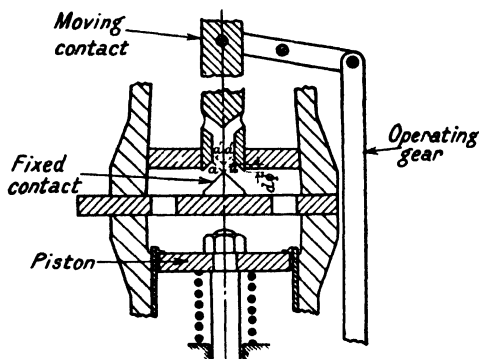

FIG. 258. DIAGRAMMATICAL SKETCH OF SINGLE-BREAK IMPULSE OIL CIRCUIT-BREAKER

amperes and restriking voltages between 80 and 800 volts per μ sec.

A larger breaker was then made with eight short breaks in series of the form shown in Fig. 259. The test voltages in this case went up to 242 kV. line to earth, with restriking voltages up to 5 200 volts per μ sec. (Prince, 1933.)

The analysis of the test records on both the above breakers supplied the following data—

(1) The current to be broken and the line voltage had no influence upon the efficiency of the breaker when clearing a short-circuit, but correct operation was a direct function of the rate of rise of the restriking voltage and oil velocity. In other words, for a given rate of rise there was a minimum oil velocity below which the breaker would fail, irrespective of the line voltage or the current to be broken. This phenomenon was

so marked that the breaker could be made to fail or clear at will by adjusting the rate of rise of the restriking voltage.

(2) The dielectric strength of oil under impulse conditions is 550 000 volts per in. By using this value for oil, the oil velocity required for any particular rate of rise of recovery voltage can be established. To take the example given by Prince, assuming an oil velocity of 120 ft. per sec., the dielectric

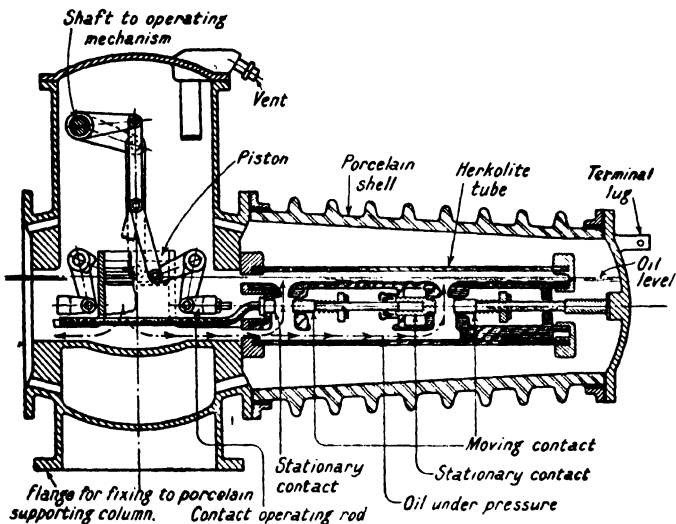

FIG. 259. PART SECTIONAL DRAWING OF THE INTERRUPTING UNIT OF A 138 kV. IMPULSE CIRCUIT-BREAKER

(In order to show the operation clearly several detail parts have been omitted and only one-half of the breaker shown.)

(General Elec. Co. (U.S.A.))

strength of this oil flowing in between the contacts increases at the rate $120 \times 12 \times 550\,000 = 792 \times 10^6$ volts per sec. If the recovery rate of the restriking voltage is greater than this amount, the arc may restrike.

(3) Although the voltage recovery rate proved the critical factor immediately after a current zero, the normal voltage of the system has to be catered for. For this reason an adequate total break capable of standing the one minute over-potential test is necessary. A multibreak contact enables the necessary total clearance to be obtained, apart from increasing the number of oil films obtained during opening operations. Furthermore,

the energy required to impart the necessary oil movement is kept to a minimum.

Impulse breakers for use on the higher voltage range have since been designed, and a description and test report on a 138 kV. circuit-breaker have been published. (Prince and Böhne.) An important point disclosed is the speed of operation, which can be seen from the following two test examples.

Test Voltage	Rate of Rise of Restriking Volts per μ sec.	Current in Arc r.m.s.	Time from Trip Impulse to Interruption, μ sec.	Arcing Time, Sec.
132	2 000	2 900	0.040	0.0117
176	4 200	1 810	0.046	0.0134

The same operating principle as used in the single-phase breaker already described has been adopted. In this case, however, a total of four breaks has been used for each phase, all of which are fed with oil from a common piston, which again is spring controlled. A diagrammatic drawing of the circuit-breaker is shown in Fig. 259.

The interrupting unit is contained in two horizontal porcelain and the central metal housing which connects them together. This complete assembly is mounted on a porcelain column which insulates it from earth. The pedestal insulators also contain the current transformers and the operating rods connecting the circuit-breaker to the operating mechanism, which can be seen at the base. The reduction in the oil quantity necessary for arc rupturing and insulation purposes is made possible by the unique construction of the circuit-breaker.

The circuit-breaker tank consists of two paper product insulation tubes (herkolite), and the central metal casting. As these parts are insulated from earth by the supporting pedestal insulators, the only clearances necessary are those affecting breaking capacity and the voltage distribution between the contacts and the incoming and outgoing terminals. The oil quantity required to fill the insulation tubes, porcelain and central body casting to the required level is 82 gal. per

phase, as compared with a quantity of 900 gal. or more for a conventional circuit-breaker. The insulation tubes prevent the pressure produced by the piston, or the arc itself, from being transmitted to the outer porcelain.

A full description of this circuit-breaker is given in the article referred to on page 423 by Prince and Böhne.

Future Trend. During the past ten years the rate of development in high voltage switchgear has been considerable, yet it seems probable that the pace may be even greater in the near future. Putting on one side such radical and largely speculative developments as d.c. transmission at extremely high voltages, the greatest potentiality for change is in the circuit-breaker. The vested interests in a.c. transmission will for a long time be a deterrent to d.c. transmission.

A few years ago, it was customary to presume that the highest breaking capacity likely to be needed would be 1.5×10^6 kVA. at any voltage. To prevent greater concentration of power, reactors would be used, or the system would be split in some way. To-day, in this country, there are single generator units of 108 000 kVA., and in the U.S.A. of very nearly twice that figure. Since it is not practicable to run a system completely segregated with one unit on each part and no standby, it is very evident that breaking capacities higher than 1.5×10^6 kVA. will be necessary in the near future.

The largest generators at present in use have an output much greater than can be carried over a single feeder at the voltage of 132 kV. Even with present means of consumption, it is clear that the national demand in this country is bound to increase considerably during the next few years. This leads to the corollary that the greater feeder capacity will mean higher voltage for transmission. Again, the greater capacity and higher voltage on the primary side will be accompanied by a greater demand for gear of a normal rating on the secondary and tertiary sides.

It has been shown that in Europe quite marked strides have been made in the development of "oil-less" (*sic*) circuit-breakers. This, no doubt, is because of unfortunate experiences with oil circuit-breakers of limited capacity. Experiences of this kind, causing serious trouble, have not occurred in this country. For instance, there have been no bad fires or explosions caused by the failure of oil circuit-breakers, and consequently there seems little reason to believe the oil circuit-breaker will soon

be superseded. This view is emphasized by the fact that none of the oil-less designs so far known to the Authors lend themselves to complete enclosure as required by metalclad gear.

In this country the development in the oil circuit-breaker is more likely to concentrate on methods for controlling the arc and accelerating the breaker movement. Thus, with the help of extra high-speed protective relays, such breakers would enable a network to be opened on fault and closed again before synchronous machinery had time to fall out of step. Also, more effective arc control will result in a reduction in the quantity of oil required. This tendency is demonstrated by the success achieved in America with the single-break oil circuit-breaker that has arc extinction by means of an oil-blast under independent pressure, and, in this country, with the cross-jet explosion pot operated by self-generated pressure.

The investigations made so far have shown that the switching surge, which is inevitable on a system when the circuit is opened, is one of the prime factors in arc interruption. It is now known that interruption due to the effect of the surge is conditional upon the rate of rise of the front of the surge being greater than the rate of rise of the dielectric strength of the medium intervening between the arc contacts after a current zero point. These investigations have not yet, however, determined exactly how to represent this condition with the mathematical accuracy that is necessary for design purposes, although it has already been shown how to calculate the limits of the restriking voltage transient. But the question is receiving so much attention in both this country and abroad, that it needs little imagination to anticipate solution in the near future.

The demand for circuit-breakers of larger breaking capacity and for higher voltages is becoming accompanied by an appreciation that such breaking capacities must be proved. The old idea of assigned values is rapidly giving way to the desire for proved performance. Such proof, in the absence of exact data on restriking voltage and the state of the arc path, is a little vague; although since the network of a high power test plant has usually a higher natural frequency than that of a distribution system, the error is probably on the right side for the purchaser of the breaker.

Unfortunately, there is still a divergence of opinion on the interpretation of actual test results, mainly because the restriking voltage does not enter into the present conventional

apparatus is in commission. The special dipstick pockets for some of these sealing chambers can be seen in Fig. 248. The joints of all oil sealing chambers are rendered oil-tight by the use of a form of compressed cork packing specially treated with gold size and fitted between machined faces.

A system of mechanical interlocks is used to prevent incorrect operation. Thus—

(a) The oil circuit-breaker cannot be isolated or lowered into the service position until the breaker contacts are fully open ;

(b) The oil circuit-breaker tanks cannot be removed until the breaker is in the isolated position ;

(c) All contact spout orifices are closed automatically by means of a metal door or shutter when the circuit-breaker is raised from its service position ;

(d) The circuit-breaker contacts cannot be operated until the breaker is in its service position or is fully isolated ;
and so on.

A feature of special note in the metalclad scheme described above is that, by means of the travelling crane, any unit can be raised from its service position and transported to the repair house without any disturbance to the remainder of the equipment. This undoubtedly makes for ease of maintenance and efficiency.

The above general description of a particular metalclad design will indicate the lines on which the design of such apparatus may follow. But, although the main principles of this class of gear remain the same, it is entirely a matter of individual opinion as to how they shall be put into practice. In further demonstration of this, the description of a new type of metalclad oil circuit-breaker may be given with advantage.

The Single-Break Vertical Metalclad Equipment. One of the main features of the oil circuit-breaker of this equipment is the incorporation of a new arc control device. This is known as the *cross-jet explosion pot*, and is treated fully in Chapter IX. Two of the chief advantages resulting from the use of this device are—

(1) The very short arc lengths that are obtained under short-circuit rupturing conditions, and the corresponding reduction in arc duration.

(2) The consistent and reliable operation that ensues under short circuits of varying intensity.

In consequence, there seems ample justification for utilizing

only one such arc control device per phase in a breaker, instead of the conventional two. This leads to a more compact design of breaker, and, because the arc is handled by the cross-jet device within the confines of the pot, the volume of oil in the breaker tank can be appreciably reduced below that required in the open-type contact breaker. This further tends to smaller bulk in the unit as a whole.

The factors that control the dimensions of the oil tank are—

- (1) Adequate voltage clearance from live parts under oil.
- (2) Ability to withstand secondary explosions resulting from the ignition of gas that has accumulated above oil level and caused by a subsequent short-circuit interruption.

These considerations led to the design of the metalclad unit shown in Fig. 250. Here the oil circuit-breaker is shown as a built-in portion of the equipment as a whole. The cross-jet pot forms the fixed contacts, and is supported directly on the lower lead-in bushing. The lifting rod of the moving contacts is in two parts. The part to which the contact proper is attached slides in the socket at the end of the upper lead-in bushings; whilst the other part, which is a rod of insulation material, couples to the operating lever. The socket attached to the upper lead-in bushing is made in segments, and provides a good rubbing contact with the metal portion of the lifting rod during operation. A similar design of socket is contained within the cross-jet explosion pot, so that the moving contact is able to enter this and make good contact in the closed position of the breaker.

In order to prevent any possibility of the contacts seizing under extreme service conditions, the moving contact rod is made of copper and the fixed contact socket segments are made of gunmetal. This design has been justified by a large number of tests with currents as high as 81 000 peak amperes.

The manner of operating this equipment is clearly shown in the figure, and it should be noticed that complete isolation of the circuit-breaker is possible by means of the isolating switch. These isolating switches are gang operated, and each set is in its own oil chamber. Here again the bus-bars consist of aligned lengths of condenser bushings, the ends of which are in separate oil chambers. Tee-off connections are taken from the bus-bars by condenser bushings, the remote ends of which carry the fixed contacts of the isolating switch. The method of providing an earthed position for the isolating switch is also worthy of

notice. Another feature is that there is no removable oil tank for the circuit-breaker, but a hinged door is provided for inspection and maintenance purposes directly opposite to the

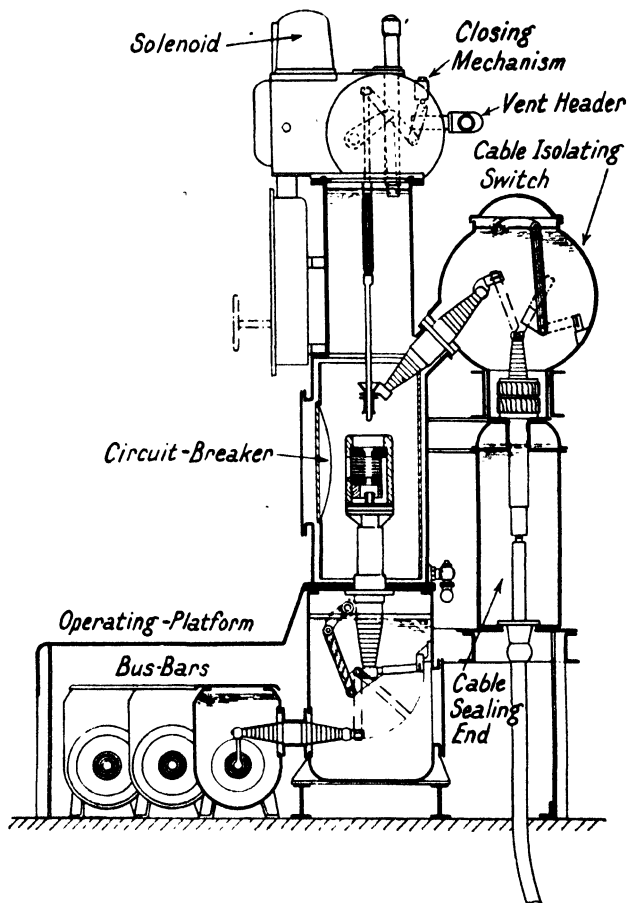

FIG. 250. 66 kV. METALCLAD UNIT FITTED WITH A SINGLE-BREAK OIL CIRCUIT-BREAKER

cross-jet pot. This door is, of course, oil tight when closed. When required, the oil is drained off by means of a drain pipe. This pipe connects with a bus pipe, whence the oil can be directed to a storage tank or filter as may be required.

132 kV. Metalclad Equipment. The metalclad gear so far

treated has been limited to 66 kV., but there is also an equipment designed for use on 132 kV. lines. This has been evolved by Messrs. A. Reyrolle & Co. Ltd., and an example of it is to be found at the Tongland substation on the Central Electricity Board's Grid scheme.

This station is an orthodox "three switch" station; a diagram of which type is given in Fig. 4.

One of the special features of this equipment is that the oil circuit-breakers used are the ordinary outdoor high voltage type of breaker, with the exception of the lead-in bushings. A sectional view of the breaker is shown in Fig. 251. The special bushings are made in two parts, one of which slides within the other. The outer and fixed portion of the bushing is of tubular section, and is built in the form of a condenser for even stress distribution. This is the part *B* in Fig. 251. The other portion of the bushing is situated within the bore of the outer cylindrical bushing, and is able to slide up and down within this bore.

This inner bushing is also of the condenser type, and carries at its lower end a poppet type contact that rubs against the inner wall of the outer bushing. The inner wall of the outer bushing is in electrical connection with the circuit-breaker stationary contact, and, by means of the sliding contact, the inner bushing is also in connection with the stationary contact over the whole length of its travel. To the top end of the inner, or moving, bushing is attached a spring-loaded butt type contact, and this meets with a similar contact on the isolating switch when the bushing is raised to its top position. This isolating portion will be described later.

The inner bushing is fitted with a tubular sleeve over the earth band. This sleeve is fitted with piston rings, and thus acts as a piston within the bore of the outer bushing extension chamber. This can be seen in Fig. 251. Also, rectangular grooves are provided at each end of the piston sleeve, and in these a latch is made to engage when the bushing is in either its extreme lower or upper position. The operation of the moving bushing is effected hydraulically. Thus, to raise the bushing, a pump, driven by an electric motor, displaces the oil from the portion above the piston rings to that below, until the pressure obtained in the lower portion is sufficient to force the bushing upwards. The lowering process is, of course, just the reverse action.

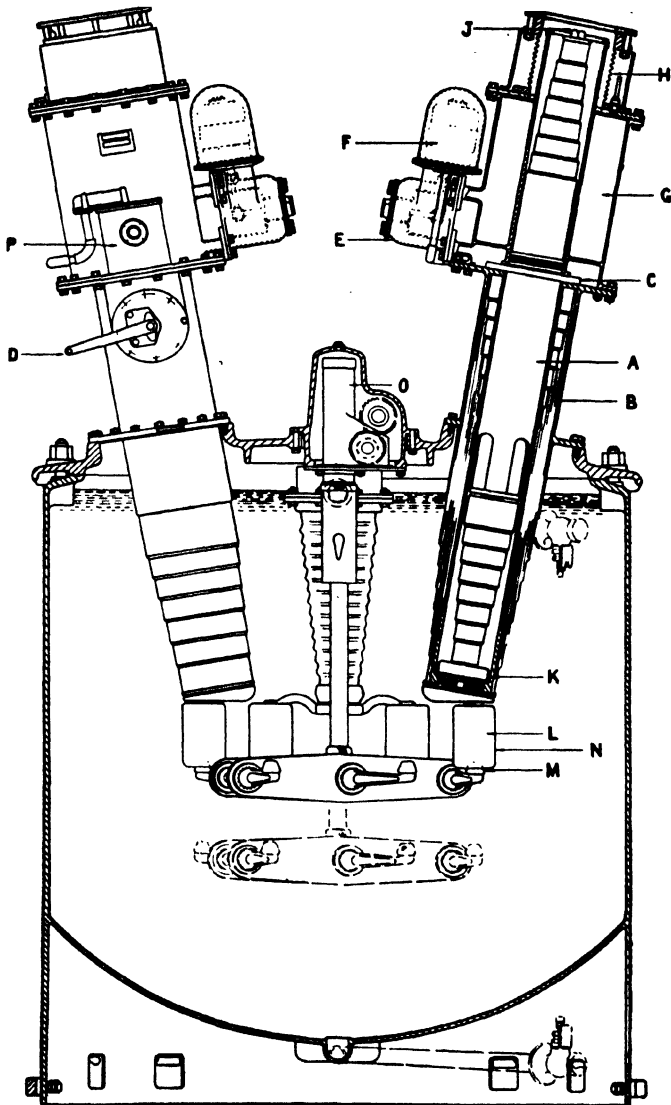

FIG. 251. SECTIONAL VIEW OF 132 KV. METAL-CLAD OIL CIRCUIT-BREAKER

- | | |
|--|---|
| A = Sliding bushing Isolator. | J = Spring-loaded butt contacts. |
| B = Fixed outer bushing. | K = Sliding contacts. |
| C = Holding-up latch. | L = Circuit-breaker fixed contacts. |
| D = Operating lever for latch. | M = Plunger bar: six breaks in series. |
| F = Oil pump for sliding bushing isolator. | N = Stress-shield. |
| F = Oil pump motor. | O = Circuit-breaker mechanism unit. |
| G = Current transformer chamber. | P = Auxiliary switches (motor circuit interlocks and indicators). |
| H = Extensible connecting trunk. | |

(A. Reyrolle & Co.)

The operating handle that controls the motor feed also controls the latch which engages in the grooves of the moving bushing. Thus when the controller is moved to the "On" position, the latch is withdrawn and the pump motor started. When the bushing has reached the end of its stroke, the latch at that end engages in the appropriate groove and, in doing so, cuts off the motor supply.

At the top of the fixed bushing, above the transformer chamber, flexible coupling sleeves are fitted; these connect with the sluice valves on the underside of the isolating switch chamber. The latter is mounted on a lattice steel structure and is therefore in rigid relationship with the ground level. For this reason the flexible sleeve is provided to permit the necessary alignment for coupling. The isolating switch chamber is shown in Fig. 252, and as the whole of the chamber is filled with oil, it will be understood that isolation is obtained under oil by lowering the moving bushings of the circuit-breaker. If the sluice valves are then closed and the flexible coupling sleeves disconnected, the oil circuit-breakers may be withdrawn for inspection or repair without disturbing the rest of the equipment.

Some of the isolating switch chambers are mounted between adjacent circuit-breakers, as shown in Fig. 252, whilst others form end units to connect together the outer poles of the circuit-breakers. The purpose of this will be easily followed if reference is made to Fig. 4, which shows the connections for a "three switch" station.

The isolating switch chamber houses three post insulators mounted at the corners of an equilateral triangle. These insulators are inverted from the roof of the chamber, and, in the case of the intermediate chambers, the ends of two of them are fitted with the butt type contacts that engage with the spring loaded contacts of the circuit-breaker moving bushings. These two contacts are permanently connected together, and one of them, which carries the isolating switch blade, is enabled to rotate so that this blade can make contact with the connection to the third insulator. Thus, the cable attached to the third insulator contact can be connected to either of its associated circuit-breakers by closing the isolating switch and raising the moving bushing of whichever circuit-breaker is required, or even both if desired.

Suitable earthing plugs are provided by means of which the

cable connections can be earthed when required. The sets of rotary isolating switches and earthing switches are coupled together and operated from pedestals mounted alongside the breaker solenoids. The same pedestals contain the interlocking

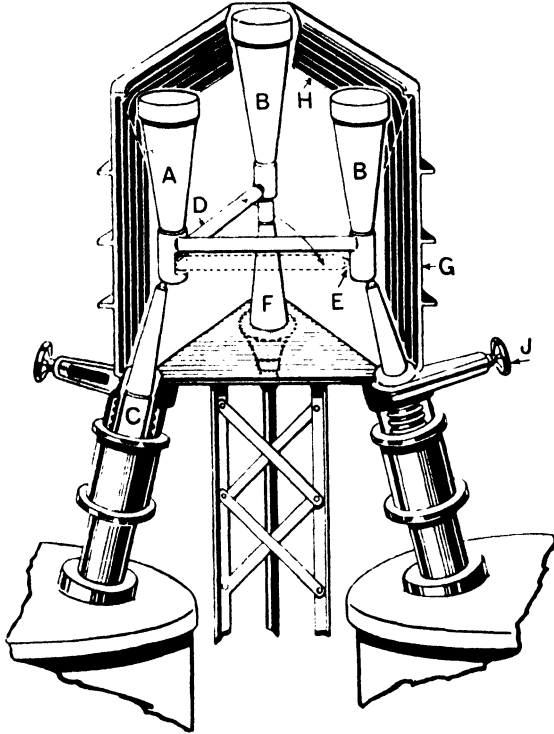

FIG. 252. ISOLATING SWITCH CHAMBER FOR 132 kV. METAL-CLAD SWITCHGEAR

- | | |
|-------------------------------------|--------------------------|
| A = Concentric Rotatable insulator. | F = Cable sealing bell. |
| B = Fixed post insulators. | G = Oil-filled chamber. |
| C = Sliding bushing insulator. | H = Insulating barriers. |
| D = Rotary isolating switches. | J = Sluce valve. |
| E = Spring-loaded butt contacts. | |

(A. Reyrolle & Co.)

mechanism between circuit-breaker, isolating switch and earthing switch, etc. These interlocks serve to prevent the circuit-breaker from being operated except when the moving bushings are in the fully closed or fully open position, and also to prevent the moving bushings from being operated until the breaker is fully open. Similarly, there are interlocks between sluce valves and moving bushings, etc.

It will be observed that all switching operations occur under oil, and furthermore that the oil level is carried to half way up the isolating switch mechanism chamber and therefore acts as an oil conservator tank. Float-operated alarm devices are fitted to give warning should the oil level fall to a predetermined level. A photograph of the actual Tongland installation of this equipment is shown in Fig. 253.



FIG. 253. 132 kV. METAL-CLAD SWITCHGEAR AT TONGLAND, SCOTLAND
(A. Reyrolle & Co.)

The connections between the switchgear, lines and transformers, and also the by-pass connection between the end isolating switch chambers, are all made with 132 kV. cables. These cables, which are of the single core type, are brought through sealing ends to the units, and a very sound and efficient coupling is thus made. Water and moisture are completely excluded by the wiped joint and lead covering of the cable.

BIBLIOGRAPHY

- H. W. Clothier, *J.I.E.E.*, Aug., 1932.
- D. R. Davies and E. I. Pilcher, *Electrical Times*, 17th Aug., 1933.

CHAPTER XVII

MODERN CIRCUIT-BREAKER DESIGN AND FUTURE TREND

Expansion Circuit-Breakers. This type of circuit-breaker was first designed for voltages up to 33 kV. The operating principle is that the circuit is broken in an inverted expansion chamber which is filled with water. With the striking of an arc, steam is generated which rapidly expands. Thus a cooling blast at high pressure is forced into the arc stream as the moving contact leaves the throat of the expansion chamber. The name "Expansion Circuit Breaker" obviously originates from the fundamental principle of its operation—the expansion of steam. At voltages above 33 kV., oil takes the place of water.

The expansion breaker, therefore, when used in the higher voltage range is virtually an oil circuit-breaker. It differs from the conventional breaker in one important feature which modifies the complete design. Oil is

used for arc quenching only and not as an insulating medium between live parts and earth. Thus the quantity of oil necessary may be of the order of 0.5 per cent of that required by a conventional oil circuit-breaker of the same rating. The breaker illustrated in diagrammatic form in Fig. 254 has the same general appearance as an insulating switch. The arc quenching device is virtually a single-break oil breaker having a bakelite tank which is protected from the weather by an outer porcelain. The fixed contact, which is of the multi-jet type, is situated at the bottom of the tank. This

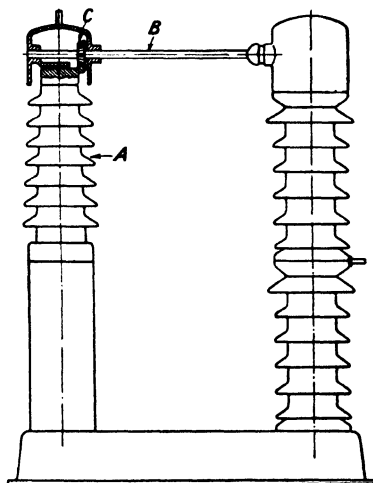

FIG. 254. DIAGRAMMATIC REPRESENTATION OF AN OUTDOOR EXPANSION CIRCUIT-BREAKER
(Siemens-Schukert)

contact is shown in Fig. 255, and an interesting feature in its construction should be noted. As previously explained in Chapter IX, the efficiency of most arc control devices varies with the current that is broken. In this case the plates forming the device are held together by compression springs instead

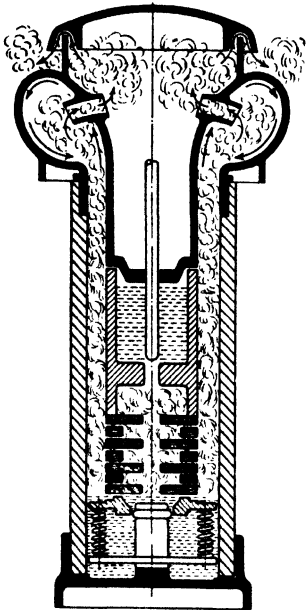

FIG. 255. DIAGRAMMATIC ILLUSTRATION OF THE ACTION OF THE CENTRIFUGAL LIQUID TRAP AND THE ARC CONTROL DEVICE

(Siemens-Schukert)

of being bolted firmly together. With the plates in the normal position, the proportions of the outlets are such as to obtain efficient operation on small currents. With higher currents and the resulting higher pressures, the plates are forced apart against the action of the springs, thus increasing the leakage clearances in proportion to the internal pressure generated. The moving rod contact moves upwards to open (see Fig. 255). As the tank is made of insulating material, its size is determined by the quantity of oil required for interruption. It is now generally accepted that the presence of carbon or other impurities in the oil has but little bearing on its arc extinguishing properties, the reason for this being that during the period of arcing the turbulence of the oil prevents the lining up of impurities to form breakdown chain paths. The fact that the small quantity of oil used in the

expansion breaker will mean that deterioration through carbonization will be accelerated is therefore of little importance, provided the oil is not meant to provide insulation between the contacts when the breaker remains in the open position. With the design of breaker in question, this insulation is obtained by incorporating an air-break switch in series with the oil-break contacts.

The operation of the breaker, which is effected by compressed air, is briefly as follows. On closing, the post insulator *A* (Fig. 254) carrying the isolating arm *B* is rotated by a mechanism

situated at its base. The contact at the end of the arm engages with its counterpart in the breaker hood, thus arresting the horizontal swing. Further rotation of the insulator revolves the arm *B* by means of the gearing *C*. This rotation is transferred by a suitable mechanism in the breaker hood to a vertical downward movement of the breaker moving contact. On opening, the sequence is reversed. Thus when the breaker contact has completed its travel, the air-break arm is swung horizontally through 90° , thereby providing the necessary insulation between the fixed and moving contacts. Successful operation depends entirely on the extinction of the arc prior to the air-break portion operating, otherwise an arc would be drawn between the isolating contacts. As an arcing time of 1 to 2 half-cycles at 100 kV. is claimed, there would appear to be an ample factor of safety against such an occurrence. It is claimed that 1 to 2 million kVA. can be ruptured in a cylinder chamber of about 8 in. diameter and $31\frac{1}{2}$ in. in height.

As the quantity of oil is small, loss through oil throwing from the vent may be serious. To prevent such losses a special shape of vent known as the *centrifugal liquid trap* is used. Its action can best be seen from Fig. 255.

When operating under ice and frozen snow conditions, it is imperative that the isolating switch contact and its operating mechanism shall be unaffected. Exhaustive tests have demonstrated the reliability of the design in this connection.

This type of breaker is manufactured in various forms by several European makers. The breaker which has been briefly described is of Siemens manufacture and has been made for voltages up to 200 kV.

Air-Blast Circuit-Breakers. This type of breaker, which dispenses entirely with oil, has been developed on the Continent of Europe and is manufactured by several firms. The design, which embraces a full voltage range of units, has passed the experimental stage, and in fact many installations have been in service for several years. In 1933 the Allgemeine Elektrizitäts Gesellschaft (A.E.G. Germany) manufactured units for 220 kV. with a breaking capacity of $2\frac{1}{2}$ million kVA.

The fundamental principle is the same for each type, in that a blast of air supplied from a reservoir is directed into the arc stream during the opening stroke. This air-blast carries away the arc products and replaces them by unionized air. It is claimed that particularly short arcing times are obtained.

Efficient operation of the breaker is obtained on low and high current values alike, as the air pressure used to extinguish the arc is independent of the arc itself.

The important design requirements are—

(1) High operating speeds.

(2) Correctly shaped air passages and contacts to facilitate high air velocities.

(3) High air pressures and assurance of air supply.

To illustrate the general design features of this class of circuit-breaker, and to show the manner in which the requirements enumerated above are satisfied, the 100 kV. circuit-breaker manufactured by the A.E.G. Co. of Germany has been chosen as a typical example to describe.

Fig. 256 shows a section through a single-pole unit of this breaker. The base *A*, which is mounted on wheels, serves the dual purpose of mounting base and compressed air reservoir. The main body consists of two hollow porcelains *C* and *E*

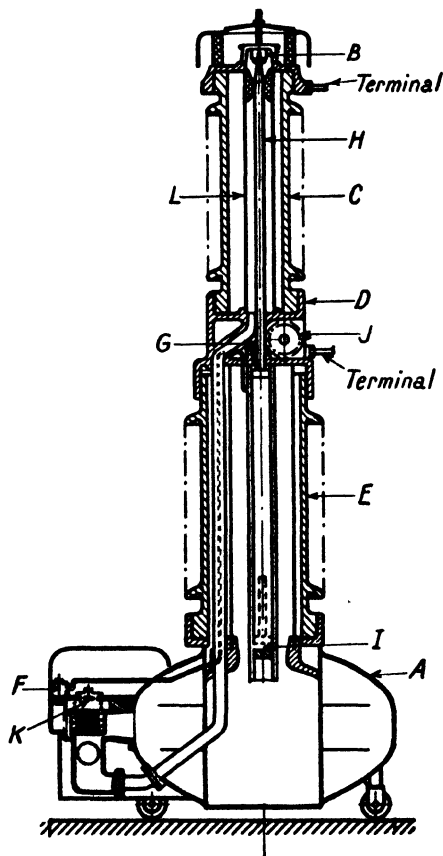

FIG. 256. SECTION OF 100 kV. AIR BLAST CIRCUIT-BREAKER (A.E.G.)

mounted in tandem; the joint between them being made at a metal centre piece *D*. The bottom porcelain, which stands upright on the base *A*, accommodates the operating cylinder for the contact rods. The current-breaking contact *B* is situated within the top of porcelain *C* and is supported by a bakelite

tube *L*, which last named may be considered as the circuit-breaker tank. This tube *L* protects the porcelain *C* from internal pressure. The head of each pole forms a silencer consisting of a slotted sheet metal casing.

When the circuit-breaker is closed, current passes from the upper connection *B* on the silencer down the moving contact rod *H* to the sliding contact *G*, which passes through the metal centre piece. The sliding contact is electrically connected to the terminal, which in turn is joined to the conductor.

The moving contact rods of the three phases are mechanically coupled to insure that all three phases shall operate simultaneously. This is accomplished by making the contact rod in the form of a toothed rack, which is made to engage with and operate the gear wheel *J*. The wheels on each of the three pole units are mounted on a common insulation shaft.

The compressed air supply for the opening stroke is released by valve *K*. A branch tube is taken from the central metal piece to the top side of the moving contact rod piston.

This arrangement ensures that the opening movement cannot commence until the tube *L* is filled with compressed air. Immediately the contacts part, this air discharges through the fixed contact throat, sweeping away the arc in its path. The hot gases ejected are not allowed direct access to the atmosphere, but are led through a layer of metal rings in the silencer in which they are cooled, and in which all the metal vapour contained in the gases is deposited.

To close the circuit-breaker, compressed air is fed through a second small valve *F* via suitable pipes to the bottom of the cylinder *I*, thus forcing the contact rod upwards.

A further air pipe, connected through a throttle valve with the compressed air tank, supplies a constant small current of air through all the internal spaces. Since this air is decompressed from the tank pressure to atmospheric pressure, it is perfectly dry and so prevents the deposition of moisture in the interior.

The air supply is obtained from an electrically-operated compressor, which automatically starts up when the pressure in the storage tank drops to a predetermined value. Alarms are fitted to warn the operating staff should the pressure, for some reason, drop to a dangerous level.

Fig. 257 shows a 6 500 A. 220 kV. air-blast circuit-breaker.

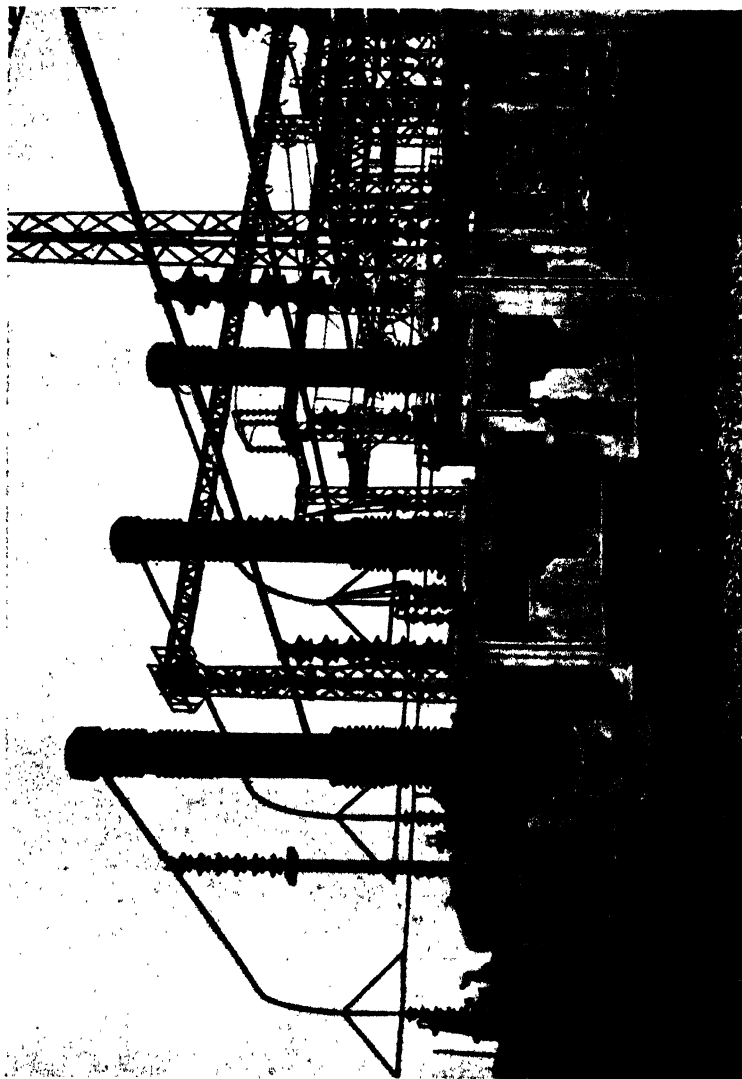

FIG. 257. AIR-BLAST CIRCUIT BREAKER, 220 000 V., 2 500 000 KVA., INSTALLED IN PARIS
(A.E.G.)

method of calculating the breaking capacity. Very strong efforts are being made by the International Electro-technical Commission to reconcile these different opinions, so that at least circuit-breaker designers may approach the new problems associated with the restriking transient, with the knowledge that co-workers in other parts of the world, are starting from the same mark. No doubt, within the next few years there will be an international specification for circuit-breaker rating that will take full account of the restriking transient.

The important factor in the investigation of circuit breaking is the use that has been made of the cathode ray oscillograph. This instrument provides a clear record of the phenomena that occur during the period of arc interruption, and without its aid, the study of these would have been considerably handicapped. It has lately been shown that the circuit-breaker itself may, and usually does, affect the restriking voltage wave, both as regards slope and amplitude. At present, the form and magnitude of this restriking voltage wave is read from the cathode ray oscillogram; rarely is an attempt made to include the circuit-breaker effect in the calculations for restriking voltage. Yet it is certain that this must eventually be done if the science is to enable circuit-breakers to be designed with precision for definite breaking capacities. It is within the bounds of possibility that ultimately a breaker will be developed that will itself control the restriking transient to a value within its own capacity for interruption. This would be opposed to the modern school of design which aims at extinguishing the arc by force, irrespective of the restriking voltage characteristics.

Similarly it is possible that as the study of the conductance of liquids and gases progresses, there may be a synthetic medium evolved which will have the necessary insulation quality as a liquid, and also will volatilize into a gas or gases that will have a high dielectric strength.

Another source of trouble on which the use of the cathode ray should throw light is that of line surges which occur from lightning, etc. The ideal lightning arrester has yet to be evolved, but here again arises the necessity for understanding not only the nature of the surges themselves, but also the behaviour of various substances when submitted to the action of such impulses. In fact, there is so much research to be done on the nature of insulation, that it is impossible to say with

any degree of certainty, to what extent modern equipment may be revolutionized in the near future.

An example of the study of the application of materials is that of glass for the purpose of outdoor insulators. Porcelain has long held the field in this respect, but glass can now be made which is almost unbreakable, and is in every way equal to porcelain. The old drawback that glass would not withstand the inherent stress test has been entirely overcome in the new product of armoured glass. The latter will pass a thermal cycle test with temperature limits at least as extreme as those for porcelain. It also has the advantage that internal flaws can be easily detected.

Automatic Reclosing. It is agreed that many troubles on overhead transmission lines are of a transitory nature, and it is most inconvenient that these should result in loss of load to the system and loss of supply to its users. Many line faults are cleared immediately when the circuit-breaker opens, and would not recur if the breaker closed again at once. An example of this is the arc-over on an insulator which will follow the short-circuit made by the body of a bird that alights against it. The bird may be killed and its body fall clear, but the arc-over once established will persist until the circuit is broken. Or, again, a power arc may follow the spark-over from a voltage surge with the same result. Yet if the circuit is open for longer than a given time, synchronous plant will fall out of step and the load will be lost. There are many such faults on large outdoor systems. In fact, a report issued by Anderson on service experience suggests that between 70 and 90 per cent of line faults are due to insulation flash-overs of this nature, all of which are cleared immediately by the opening of the oil circuit-breaker.

There are already existing a number of schemes for automatic reclosing of the circuit-breaker after it has tripped out on fault, but these generally allow a time lag between the tripping and reclosing which is altogether too long for transmission line application. Therefore, the development of a circuit-breaker which incorporates the feature of immediate reclosing is so desirable that the advent of such a product is imminent. The design of a device of this kind must, however, involve a special circuit-breaker, since the inertia of the ordinary type of breaker would prohibit the speed of operation required. The actual time interval between opening and reclosing is not easy to

determine, and it will, of course, vary for different systems. It will be governed by the capacity of the synchronous machinery interconnected, by the characteristics of the transformer feeding the network, and by the line characteristics. Should the time interval required be between 6 and 10 cycles, it is possible that circuit-breakers of the type described in the first part of this chapter could be modified so that they would fulfil the requirement.

The automatic reclosing circuit-breaker just considered must not be confused with the many types that are already in existence for reclosing breakers of the ordinary slow kind. The object of the former type is to open and reclose the circuit within a time interval that will prevent synchronous plant from falling out of step; whereas the latter type is for use on circuits on which there is no synchronous plant connected that would be affected in that manner.

BIBLIOGRAPHY

- A. E. Anderson, *J.A.I.E.E.*, Jan., 1934.
- J. Biermanns, *A.E.G. Progress*, Sept., 1929.
- Brown Boveri Review*, Jan.-Feb., 1934.
- F. Kesselring, *Elec. Rev.*, May, 1931.
- D. C. Prince, *Gen. Elec. Review*, Aug., 1933.
- D. C. Prince and C. W. Böhne, *Elec. World*, June, 1934.
- D. C. Prince and E. J. Poitras, *Elec. World*, Feb., 1931.
- Siemens Review*, Vol. X, No. 1, 1934.



**OUTDOOR OIL-IMMERSED
CIRCUIT BREAKERS for 161,000 VOLTS
2,500,000 KVA**

*One of twelve of the
largest and the highest
voltage CIRCUIT
BREAKERS ever
built in England
"METROVICK"*



**METROPOLITAN
Vickers**

ELECTRICAL

CO. LTD.

TRAFFORD PARK ... MANCHESTER 17.



INDEX

A

- ACCELERATION of electron, 133
- A.c. component, 180
- Actual wind velocity, 29
- Air-blast circuit-breakers, 411
 - break switches, 99
 - clearances for oil circuit-breakers, 218
 - cushion above oil, 169
 - density, Correction factor for, 25
 - , electrical clearances, 36
- Altitude, effect of on spark-over, 25
- Analogy of electric circuit to Hook's law, 54
 - of electrostatic quantities to electromagnetic quantities, 54
- Anemometer method of measuring wind velocity, 29, 30
- Angle of needle point and field form, 223
 - of wedge type contact, 204
- Anode potential drop, 135
- Application of differential directional relays, 378, 380
 - of lightning arresters, 318
- Application of protective systems—
 - to e.h.v. schemes, 365
 - to mesh station, 370
 - to "one-switch" station, 365
 - to parallel feeders, 375
 - to "three-switch" station, 368
- Arc control devices, 205
 - cross-jet, 211
 - de-ion grid, 208
 - oil-blast, 207
 - turbulator, 213
- Arc energy, 142, 148
 - , liberation of, 158
 - extinction, methods of, 134
 - gas bubble, 148
 - hysteresis, 140
 - phenomena, 127
 - temperature, 150
 - voltage, 134
- Arcing-ground suppressors, 320
- Arens control mechanism, 238
- Attenuation of travelling waves, 304
- Automatic reclosing, 422
- Autovalue type lightning arrester, 310

- Auxiliary switches, 390
 - wiring, 388

B

- BAROMETRIC pressure, effect on spark-over, 25
 - Bases for isolating switches, 107
- Beard switching arrangement, 7
- Bearings for rotating insulators, 107
- Bolts, limiting sizes of for structures, 31
- Breakdown value of lightning arrester, 310
 - voltage of oil, 220
- Breaking capacity, 187
 - of contactor for closing solenoid, 248
- Break-jaw contacts for isolating switches, 108
- Bus-bars, 282
- Bushing insulators, 263
 - condenser type, 268
 - design data, 274
 - dielectrics in series, 270
 - Hermendorf type, 266
 - oil-filled type, 270
 - test methods, 277
 - voltage tap, 272
- Bushing type current transformer magnetization curve, 385
 - — — transformers, 382
- Butt type contacts, 202
- By-pass isolators, 9

C

- CABLES for small wiring, 388
- Calculation for size of cable for solenoid of O.C.B., 390
 - of breaking capacity, 188
 - of lever system in contact lifting mechanism, 235
 - of relay setting, 385
 - of restriking voltage, 183
 - of tank strength, 198
- Cap-and-pin type insulators, shape of porcelain body, 60
- Capacitance of bushing, 265
 - of two co-axial cylinders, 264
- Carbon deposit in oil, measure of, 160
 - tetrachloride fume, 343

The First and Simplest Metal-Clad Unit-Type Switchgear for 66,000 Volts and over

OUR ANNOUNCEMENT IN NOVEMBER 1932

NOTABLE ACHIEVEMENTS

The Westinghouse
Company
Manufacturers of
Switchgear
and
Electrical
Equipment
Since
1887
The
Westinghouse
Company
is
the
only
manufacturer
of
switchgear
in
the
United
States

SWITCHGEAR OF THIS 66,000-VOLT DESIGN WAS
FIRST PUT INTO COMMISSION IN NOVEMBER 1931

OUR ANNOUNCEMENT IN APRIL 1931

The 1931 Report of the Central Electricity Board refers to switchgear illustrated here as "the first 66,000-volt outdoor metal-clad switchgear to be adopted in this country"; and the 1932 Report says of the 132,000-volt switchgear shown above that it is "a notable major development in switchgear design" and that "the experience gained indicates that the new construction may have a far-reaching effect on high voltage switchgear design throughout the world"



- Marriage type isolating switch, 106
 Cathode potential drop, 135
 Cathode-ray oscillograph in testing, 95
 Cement, expansion of, and insulator troubles caused by, 80
 —, physical properties of, 82
 —, steam curing of, 80
 Cementing of porcelain insulators, 80
 Chimney effect, 167
 Choice of insulators for fouled conditions, 76
 — of suitable site for outdoor station, 22
 Choke coils, 330
 Circuit-breaker—
 air-blast type, 411
 expansion type, 409
 impulse type, 415
 metalclad type, 392
 oil type, 192
 operating mechanism, 242
 Circuit isolation, outdoor stations, 37
 Clay composition of, for porcelain manufacture, 43
 Cleaning of insulators, 74
 Clearances (Air), effect on steelwork structure, 31
 — (Air), Tables from B.S. Specifications, 36
 —, American standards of, 18–20
 — for oil-circuit breakers, 218
 Coefficient of friction on Arens' control, 239
 — of recombination, 133
 Comparison of costs for concrete and steel structures, 33
 — — — for high and low stations, 18
 — of oil-filled and condenser bushings, 275
 Composition of oil, 160
 Compressed air operating mechanism, 260
 Concrete rafts, when required, 23
 Condensation in circuit-breakers, 196
 Condenser bushing, 268
 Connections, 282
 Contact energy, 159
 Contact-lifting mechanism, 231
 Contacts, butt type, 202
 —, de-ion grid type, 208
 —, finger and wedge type, 203
 — for circuit-breakers, 201
 —, plug and socket type, 204
 —, turbulator type, 213
 Co-ordinating gaps, 333
 Co-ordination of insulation, 333
 Corona in oil, 220
 — loss on conductors, 283
 — shields and stress distributors, 222
 Creeping sparks, 221
 Critical angle for insulator section joints, 82
 — speed of opening for arc interruption, 145
 Cross-jet explosion pot, 211
 Current reflections, 300
 — transformer ratio, effect of, 387
 — transformers, bushing type, 382
 — — in parallel, effect of on relay setting, 386
 Curves of loads on mechanism and oil circuit-breaker, 233
 Cut-off voltage of lightning arrester, 310
- D
- DAMPING device for conductor vibration, 290
 Dashpots, 240
 oil spring type, 242
 oil type, 241
 spring buffer type, 241
 D.c. cables for solenoid coils, 390
 — component, 180
 Dead weight loading on steel structures, 29
 Definite impedance relay, 351
 De-ion grid contact, 208
 Design and testing of pedestal insulator, 53
 Dielectric field, the, 54
 — strength of oil under impulse, 417
 Dielectrics in series, 270
 — —, stress distribution resulting from, 59
 Differential directional relays, 376, 377
 Diffraction of electrostatic lines of force, 62
 Direct sub-transient reactance, 178
 Dirt deposits, 70
 Discharge gap of lightning arrester, 305
 Discontinuity, reflection from, 302
 Displacement of current, 180
 — theory of arc extinction, 207
 Dissociation of gases, 155
 — of oil by arcing, 151
 Double bus station, 8
 Dry and wet spark-over values of pin-type insulators, 83

PORCELAIN INSULATORS

FOR

E.H.T. SWITCHES AND CIRCUIT-BREAKERS

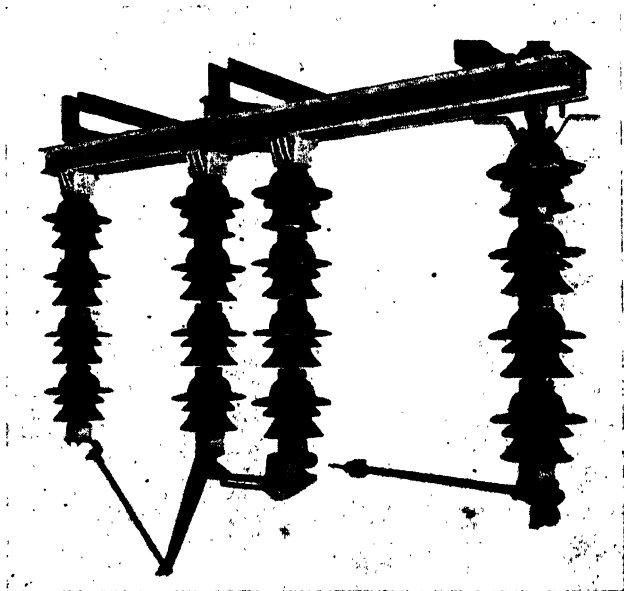

This illustration, reproduced by kind permission of The Metropolitan Vickers Electrical Co., Ltd., shows their type G.D.1—R.S.C.1 underhung 110 kV. isolating switch equipped with Taylor Tunnicliff post insulators.

The reliability of a switch or circuit-breaker obviously cannot be greater than that of the insulators used in its construction.

It is therefore essential that only the best be used.

TAYLOR TUNNICLIFF & CO. LTD.

Manufacturers of Porcelain Insulators of all Types

Eastwood, Hanley, Staffs., and 110 Cannon Street, London, E.C.4

- E**
- EARTHING** switches, 121
- Effect of—**
- cables on restriking voltage, 175
 - diffraction on spark-over, 62
 - electric force on insulator fouling, 71
 - field form on spark-over, 58
 - impurities and moisture in oil, 229
 - neutral impedance on restriking voltage, 182
 - rainsheds on spark-over, 63
 - solid di-electrics in an air field, 58
 - temperature change on circuit-breaker bushings, 196
- Effect on spark-over—**
- by dirt deposits, 70
 - by fog, 67
 - by rain, 66
 - by wind and humidity, 69
- Electrical clearances, 18–20, 31, 36, 218
- Electron drift, 128
- Energy of lightning discharge, 295, 296
- Equation for arc voltage, 135, 136
- Equipotential surfaces, 61
- Erection and maintenance loadings on steelwork, 30
- Escape energy of the electron, 130
- Examples of parallel feeder protection, 378
- Expansion of cement and insulators, trouble caused by, 80
- , trouble, cure of, 81
 - type circuit-breakers, 409
- Explosion type contact—
- cross jet, 211
 - de-ion, 208
 - oil-blast, 207
 - plain, 205
 - pressure/travel curve, 214
- Expulsion fuse, 346
- F**
- FACTOR** of safety, for steel structure members, 32
- Ferranti surge absorber, 317
- Field form—**
- effect on spark-over, 58
 - methods of plotting, 57
 - of needle point, 223
 - of sharp-edged cylinder, 225
- Finger and wedge type contacts, 203
- Finish for outdoor steel structures, 32
- Fluxes, as vitrifying agents in porcelain manufacture, 45
- Fog, effect of, on spark-over, 67
- “Fog type” insulators, 72
- Fouling, effect of electric force on, 71
- , — of, on insulator spark-over, 69
- Foundations, different types of, 23
- , loadings on concrete, 31
- Fuses—**
- carbon-tetrachloride type, 343
 - expulsion type, 346
 - oil-blast type, 344
 - outdoor high voltage, 342
 - “Quencho” type, 344
- G**
- GALVANIZING** of steelwork members, 32
- *versus* paint, 32
- Gang-operated switches, 103
- Gas bubble from arc, 148
- gap, strength of, 131
 - volume and pressure, 164
- Gases liberated by arc in transformer oil, 150
- Glazing of insulator porcelains, 49
- Grading of insulation, 333
- Growth of current and voltage in a circuit, 173
- H**
- HEAD** of oil, 164
- Heat loss from arc due to radiation, 159
- Heaters for oil circuit-breaker tanks, 196
- Hermendorf bushing, 266
- High frequency, effects on restriking voltage, 182
- — spark-over, 93
 - — test on insulators, 89
 - structures, reinforced concrete type, 33
 - voltage fuses, 342
- High-type stations, 12
- Humidity, effect of on insulator tests, 84
- , — on discharge gap, 339
 - , — on insulator spark-over, 69
- Hydrogen, dissociation of, 162
- I**
- ICE** loading on apparatus, 29
- Impedance system, protective gear, 351
- Impedance-time relay, 352

**MOST INTERRUPTIONS OF SUPPLY
CAN BE AVOIDED**

BY INSTALLING

A.E.G. PETERSEN COILS

**DAMAGE THROUGH LIGHTNING
IS PREVENTED**

BY

A.E.G. SURGE ARRESTERS

*Let us advise you how to prevent
trouble before the damage is done*

**A.E.G. India
Electric Co. Ltd.
P.O. Box 608
Bombay**

**A.E.G. Electric Co. Ltd.
131 Victoria Street
LONDON, S.W.1**

**A.E.G. Engineering Co. (S.A.)
(Proprietary) Ltd.
P.O. Box 4554
Johannesburg**

- Impulse ratio, 94
 — regulation curves for lightning arresters, 316
 — spark-over, 93
 — strength of insulation barriers, 335
 — testing, 95
 — type circuit-breaker, 415
 Impurities in oil, 228
 Indicated wind velocity, 29, 30
 Indoor mounting of apparatus, 35
 Initiation of arc, 131
 Insulation barriers, 226
 Insulators, design and testing of pedestal type, 53
 —, moisture films, 3
 Interference, 320
 Interlock protective system, 364
 Interlocking in metalclad switchgear, 401
 Interruption of arc, 127
 Ionic saturation, 136
 Ionization potential, 153
 Isolating switch—
 definition, 99
 horizontal break, gang operated, 103
 operation, 30
 rocker type, 105
 single pole, stick operated, 99
 vertical-break type, 105
 Isolation of sections and circuits, outdoor stations, 37
- L
- LANGMUIR's equation for dissociation energy, 162
 Lapp fog-type insulators, 74
 Lattice steel structures, 28
 — type concrete structures, 33
 Laying of multicore cables, 389
 Lever and toggle mechanisms, 233
 Lightning arrester—
 application of, 318
 auto-valve type, 310
 breakdown value, 310
 cut-off voltage, 310
 discharge gap, 305
 function, 385
 Thyrite type, 313
 VA characteristics, 312, 313, 315
 voltage ratio, 310
 Lightning surge protection, 294
 Limit of high type reinforced concrete structures, 33
 Limitation of frame mounted oil circuit-breaker, 192
 — of sphere gaps, 335
- Line surges and reflections, 298
 Load breaking air-break switches, 99
 — curve of contact lifting mechanism, 232
 Loading on steel structure members, 32
 Lock-in protective system, 356
 Logarithmic function of voltage wave, 175
 Low current arcs, 139
 — type concrete structures, 33
 — outdoor switchgear stations, 13
- M
- MAGNETIZATION curve for bushing-type current transformer, 385
 Maintenance, 20
 — of oil circuit-breakers, 199
 Making capacity, 188
 Manufacturing limits of insulators, 78
 Marking of steel structure members, 32
 Maximum and minimum insulator spark-over values, 96, 339, 340
 — spark-over value, 307
 Mechanical tests on insulators, 88
 "Mesh" station, protective scheme, 370
 — type station, 8
 Metalclad switchgear, 392
 Metallic atom, The, 127
 Minimum voltage to re-start arc, 172
 Mobility of the ion, 133
 Moisture films on insulators, 3
 — in oil, 229
 Motor-operated mechanism, 254, 256
 Multicore cables, 388
 Multiple arc breaks in series, 146
 — frequency circuits, 186
 M-V type "K10" metalclad switchgear, 395
- N
- NATIONAL Specifications, for outdoor stations, 17
 Needle point and field form, 223
 Non-pilot-wire protective relays, 351, 352, 360, 375, 377
 Notes on isolation of sections and circuits, 37
 Nuts, weather protection of, 32
- O
- OIL, 226
 breakdown voltage, 220
 calorific value of, 160

PUBLISHED BY PITMAN

INSTRUMENT TRANSFORMERS

Their Theory, Characteristics and Testing

A Theoretical and Practical Handbook for Test-Rooms and Research Laboratories and Measuring Instrument Designers.

By B. HAGUE, D.Sc. (Lond.), Ph.D. (Glas.), F.C.G.I., D.I.C., M.I.E.E., M.A.I.E.E., F.P.S.L.

An exhaustive treatise on the design and application of these most important components in modern high tension electrical measuring apparatus. The author has drawn on the accumulated experience of designers and engineers of many nations for his material.

In demy 8vo, cloth gilt, 684 pp. **35s.** net.

PROTECTION OF ELECTRIC PLANT

MODERN DEVELOPMENTS

By P. F. STRITZL, D.Sc. Tech. (Vienna), Chief Electrical Engineer, A.E.G. Electric Co., Ltd.

Deals with the devices for electrical plant which have been developed mainly on the Continent, although British and American apparatus of special interest is included. Each protective system or apparatus is dealt with in relation to its most important field of application. The co-ordination of the various existing protective systems is discussed, and suggestions are put forward regarding the selection of protective gear for various kinds of electrical plant.

In demy 8vo, cloth gilt, 200 pp. **18s.** net.

ELECTRIC CIRCUITS AND WAVE FILTERS

By A. T. STARR, M.A., Ph.D., A.M.I.R.E.

A textbook for telegraph engineers, wireless engineers, and advanced students who wish to obtain a clear and comprehensive grasp of the fundamental principles of wave filters.

ABRIDGED CONTENTS: Notation and Abbreviations—Fundamentals of Alternating Current Theory—Theory of Electric Circuits—Design of Resistances, Coils, and Condensers—Two-Terminal Impedances—Four-Terminal Networks—Wave Filters—Low Pass Filter—High Pass Filter—Band Pass Filter—Calculation and Measurement of Performance—Transients in Networks—Index.

In demy 8vo, cloth gilt, 376 pp. **21s.** net.

AUTOMATIC PROTECTIVE GEAR

FOR A.C. SUPPLY SYSTEMS

By J. HENDERSON, M.C., B.Sc., A.M.I.E.E.

This book provides sound instruction in the principles and problems relating to the protective systems used in modern electricity supply practice. It is an excellent textbook for students, and a practical work of great value to all electrical power engineers. It provides authoritative information that is the result of direct association with the use of all types of protective gears, and it will prove of unique assistance for practical reference.

In crown 8vo, cloth, 212 pp. **7s. 6d.** net.

Sir Isaac Pitman & Sons, Ltd., Parker Street, Kingsway, London, W.C.2

- Oil 228, (*contd.*)—
 circuit-breaker design, 192
 clearances, 228
 — for oil circuit-breakers, 218
 composition of, 160
 dashpot, 241
 dielectric strength of under im-
 pulse, 417
 dissociation by arcing, 151
 energy of dissociation, 159
 for circuit-breakers, 196
 purifying plant, 230
 spring dashpot, 242
- Oil-blast explosion pot, 207
 — fuse, 344
- Oil-filled bushing, 270
 "One-switch" station, 8
 — — —, protective scheme, 365
- Operating coils, 247
- Operating mechanism, 242
 B.T.H. form B2, 256
 centrifugal motor type, 255
 compressed-air type, 260
 flywheel type, 255
 F.P. solenoid type, 252
 motor type, 254
 M.V. solenoid type, 249
 solenoid type, 245
 spring type, 255
- Operation of isolating switch, 100
- Oscillogram of short-circuit test,
 189
- Outdoor high voltage fuses, 342
 — station lay-outs, 5
- Overall dimensions of circuit-breakers,
 193-5
- P
- PARALLEL feeder protection, 375
- Pedestal insulators, 61
- Percentage of free electrons in an
 arc, 132
- Photo-electric work function, 130
- Physical properties of cement, 82
 — of porcelain, 82
- Pilot lead resis., effect of on relay
 setting, 386
 — wire protective relays, 348, 356,
 358, 364
- Plug and socket type contacts, 204
- Point-plane oil gap, 227
- Pole interconnecting gear, 197
- Porcelain, manufacture of, 43
 —, physical properties of, 82
- Porosity test on insulators, 89
- Positive ion, the, 127
- Power factor, effect on arc interrup-
 tion, 132
- Pressure within the electric spark, 169
- Pressure/travel curve—cross-jet pot,
 214
- Proportion of sand and cement for
 insulator joints, 81
- Protected leakage-path insulators, 72
 — — —, disadvantages of, 74
- Protective gear, 348
 impedance system, 351
 interlock system, 364
 lock-in system, 356
 ratio-balance system, 360
 split-pilot system, 357
 "Translay" system, 348
- Puncture testing of insulators, 88
- Q
- QUADRATURE sub-transient react-
 ance, 178
 "Quencho" high voltage fuse, 344
- R
- RACK-AND-PINION mechanism, 237
- Radiation loss of heat from arc, 159
- Rain, effect of on spark-over of in-
 sulators, 66
- Rainfall, effect on discharge gap, 340
- Rainsheds, effect on wet spark-over
 value, 64
 — on insulators, 61
 —, spacing of, 63
- Rain-washed insulators, 74
 — — —, disadvantages of, 75
- Rate of recombination of ions, 133
- Ratio of dry to wet spark-over of
 insulators, 63, 64
- Ratio-balance protective system, 360
- Recovery voltage calculation, 183
- Reduction in oil strength due to im-
 purities and water, 230
- Reflection of surges, 298
 — — on short-circuited lines, 301
 — — on tee lines, 303
- Reinforced concrete structures, 33
- Relation between circuit parameters
 and voltage, 173
- Relative air density, effect on dis-
 charge gap, 340
- Relay protective gear, 348
 — setting, calculation for, 385
- Resilient coatings for porcelain
 cemented joints, 81
- Resistance leakage form factor for
 insulators, 73
- Resistivity, value of for rain water, 66
- Resonance potential, 153
- Restricted earth-fault protection, 374
- Restriking voltage, 172, 185

PUBLISHED BY PITMAN

Alternating Current Bridge Methods

For the Measurement of Inductance, Capacitance, and Effective Resistance at Low and Telephonic Frequencies.

By B. HAGUE, D.Sc. (Lond.), Ph.D., F.C.G.I., D.I.C., A.C.G.I., M.I.E.E., M.A.I.E.E., F.P.S.I., *Lecturer in Electrical Engineering in the University of Glasgow.*

A theoretical and practical handbook for the use of advanced students.

In demy 8vo, cloth gilt, 407 pp., with 112 illustrations. **15s.** net. Third Edition.

Transformers for Single and Multiphase Currents

By DR. GIBERT KAPP, M.Inst.C.E., M.I.E.E., *late Professor of Electrical Engineering in the University of Birmingham.*

A treatise on their theory, construction, and use. Third Edition, thoroughly revised by REGINALD O. KAPP, B.Sc.

In demy 8vo, cloth gilt, 400 pp., with 229 illustrations. **15s.** net.

Theory and Design of Electric Machines

By F. CREEDY, M.I.E.E., A.C.G.I., *Research Professor, Lehigh University, Pa.*

A treatise dealing with the fundamental principles of the design and operation of all types of electrical machines, and containing a novel method of arriving at the correct dimensions for any particular design.

In demy 8vo, cloth gilt, 350 pp. **15s.** net.

Mercury Arc Current Convertors

An Introduction to the Theory of Vapour-Arc Discharge Devices and to the Study of Rectification Phenomena.

By H. RISSIK, Hons. B.Sc. (Eng.), A.M.I.E.E., M.A.Min.E.E.

In demy 8vo, cloth gilt, 425 pp. **21s.** net.

Electrical Condensers

By PHILIP R. COURSEY, B.Sc., F.Inst.P., M.I.E.E.

A complete treatise on the design, construction, and uses of electrical condensers, both for wireless transmission and reception, and for power factor correction and other industrial purposes. A bibliography containing over 1500 references forms an important feature in the book.

In demy 8vo, 660 pp., with 514 illustrations. **37s. 6d.** net.

High Voltage Cables : Theory and Practice of Their Design and Operation

By P. DUNSHEATH, O.B.E., M.A., B.Sc., F.Inst.P., M.I.E.E.

Deals with the theory and practice of the design of cables for carrying power, particularly at the higher voltages.

In demy 8vo, cloth gilt, 174 pp., illustrated. **10s. 6d.** net.

Sir Isaac Pitman & Sons, Ltd., Parker Street, Kingsway, London, W.C.2

- "Rocker" type isolating switches, 105
 Rod gap, 334
 Roughing and knurling of porcelain insulators, 80
- S
- SAFETY regulations, 18-20
 Sag in conductors, 282
 Sand glazing of porcelain insulators, 80
 Schering bridge for testing insulation, 278
 Screens, 22
 Secondary lead resistance, effect of on relay setting, 386
 Section delimitation, 38
 Semi-strained conductors, 291
 Shape of insulator sections, 82
 Shapes of electrodes, effect on field form, 55
 ——— of solid di-electrics and their effect on the field form, 58
 Sharp-edged cylinders and field form, 225
 Shrinkage in porcelain manufacture, 46
 Single-break vertical metalclad switchgear, 401
 Slenderness ratio, for steel structure members, 32
 Snow loading on apparatus, 29
 Solenoid operating mechanism, 245, 249, 252
 Spacing of rainsheds and effect of on spark-over, 63
 Spark-over—
 correction factor for, 25
 discharge, 90
 effect of altitude on, 25, 26
 — of insulator shape on, 61
 values of rod-cap, 337
 Specific inductive capacitance (S.I.C.) 55
 Speed of break in arc interruption, 144
 Sphere gaps, limitation of, 335
 Sphere/plane oil gap, 227
 Split-pilot protective system, 357
 Spring buffer-type dashpot, 241
 Station layout, 10
 — sites, data on, 22-5
 Steam curing of cement for insulators, 81
 Steel structures, 27
 dead weight loading on, 29
 factor of safety against overturning, 31
 material specification, 31
- Steel Structures (*contd.*)—
 stresses, 32
 tension loading on, 29
 windage on, 29
 Straight-line motion in contact-lifting mechanism, 234
 Strained conductors, 282
 Strength of the gas gap, 157
 Stress diagram, 31
 — distribution resulting from di-electrics in series, 59
 — distributors, 222
 String distance spark-over values, 64
 Sub-transient reactance, quadrature and direct, 178
 Surface creepage distance, 230
 Surge absorbers, Ferranti, 317
 — impedance, 304
 — reflections, 298
 Surges, velocity of propagation of, 304
 Symmetrical components and restriking voltage, 176
- T
- TANK pressure, 169
 — raising and lowering gear, 199
 Tanks for oil circuit-breaker, 198
 Temperature cycle test on insulators, 89
 —, effect on spark-over, 25
 — of arc, 150
 — variation, effect on circuit-breaker bushing, 196
 Tension insulators, 285
 — loading on steel structures, 29
 Terminal boards, 390
 Terminals, 292
 Test methods for bushing insulators, 277
 Testing plant, 87
 Theory of breakdown of oil gap, 227
 — of operation of the explosion-pot type contact, 205
 Thermal ionization, 152
 Thermionic work function, 130
 "Three-switch" station, 7
 — —, protective system, 368
 Threshold energy, 129
 "Thyrite" lightning arrester, 313
 Time lag, effect on discharge gaps, 340
 — of spark discharge, 90
 Time-constant of circuit, 174
 Time/distance curves for impedance/time relays, 355
 Toggle mechanism, 233
 Tolerances on insulator dimensions, 78

436 OUTDOOR HIGH VOLTAGE SWITCHGEAR

"Translay" system, protective gear, 348

Transport of apparatus, precautions, 25

Travelling waves, 297

— — —, attenuation of, 304

Trip coil, 248

— — — mechanism, 249

Trunk multicore cables, 389

Tubular conductors, 286

Turbulator contact, 213

Typical protective schemes, 365

U

UNIT stresses on steel structures, 32

Use of high voltage outdoor fuses, 342

V

VA. characteristics of lightning arrester, 312, 313, 315

Value of current factor in breaking capacity, 187

— — — of secondary current in bushing current transformers, 387

— — — of test voltage, 221

— — — of voltage factor in breaking capacity, 187

Variation in test results, 84

— — — of arc temperature from core of arc to oil, 152

— — — of stress distribution between electrodes, 58

Velocity of propagation of surges, 304
Vermin, prevention of ingress to circuit-breaker tanks, 197

Vibration damping device, 290

— — — of conductors, 289

— — — test on insulators, 89

Vitrification in porcelain manufacture, 51

Voltage distribution across arcs in series, 148

— — — in the arc, 135

— — — ratio of lightning arrester, 310

— — — reflections, 299

— — — tap on bushing insulators, 272

W

WAVE-FORM designation, 96

Weather conditions, 66

— — —, effect of on discharge gaps, 338

Wedge-type contacts, 203

— — —, angle of, 204

Wet spark-over values on pin type insulators, 63

Wind, effect on insulator spark-over, 69

Wind pressure on conductors, 288

Wind velocity, method of measuring, 29, 30

Windage on steel structures, 29

CENTRAL LIBRARY
BIRLA INSTITUTE OF TECHNOLOGY & SCIENCE
PILANI (Rajasthan)

Call No.

Acc. No.

33178

DATE OF RETURN

--	--	--	--

