

GENERAL PSYCHOLOGY

GENERAL PSYCHOLOGY

RICHARD WELLINGTON HUSBAND, Ph.D.
Assistant Professor of Psychology, University of Wisconsin

RINEHART & COMPANY, INC.

PUBLISHERS

NEW YORK

FIRST PRINTING . . . APRIL 1940
SECOND PRINTING . . . JULY 1941
THIRD PRINTING . . . FEBRUARY 1945
FOURTH PRINTING . . . JUNE 1946
FIFTH PRINTING . . . JANUARY 1947

**COPYRIGHT, 1940, BY RICHARD WELLINGTON HUSBAND
PRINTED IN THE UNITED STATES OF AMERICA
ALL RIGHTS RESERVED**

P R E F A C E

IN WRITING this book I have kept three objectives constantly in mind. First, I have applied the test of practicality. I have attempted to link the topics under discussion with daily life, vocational choice, the business world, social participation. In other words, I have attempted to deal with real people in life situations. To substantiate practical suggestions I have drawn liberally on definite experimental results, as seen in the many tables, figures, and statistics quoted.

Second, I have written from a genetic point of view. I have attempted to take this stand consistently with each topic, not only when dealing with learning itself, but also with personality, emotions, intellect, and even sensations. The genetic point of view has determined to a large extent the order of chapters, a developmental order in so far as is possible.

My third objective springs from my conviction that psychology is more useful to the beginning student when considered a social rather than a biological science. I cannot, as do some authors, discuss behavior as if each person were alone in the world, for I am especially interested in helping the individual to apply psychological principles in such a way as to make himself a more acceptable and well-adjusted member of society.

In pursuing these three objectives, I have retained most of the major topics usually treated in the general psychology course, but I have attempted to present them in as practical a manner as possible. To that end I have included several chapters and many sections on definite applications of principles: to study, to teaching, to vocational choice,

to business, to rearing children, to social participation, and under a few such headings as

- Application of principles of maturation by parents and teachers
- Motivation of other people
- Reasons for failures of motivation
- Proper emotional conditioning of children
- Emotional control in adults
- Development of personality
- Uses of personality test scores
- Applications of intelligence scores to educational and vocational guidance
- Efficient learning
- Improvement of memory
- Accurate and inaccurate thinking
- Practical uses of illusions

I have purposely minimized or omitted academic discussions of some traditional topics, such as the different schools of psychology, microscopic details of nervous structure, theories of vision and audition, the James-Lange theory, theories of learning. These do not appeal to nor are they well understood by the average student. The student is more interested in what an act is like and what one can do about it than in hair-splitting definitions and quibbles on classification.

In using the experimental findings and writings of my colleagues I have attempted to give accurate citations to studies specifically quoted. Too many names are likely to confuse the beginning student; hence I have listed the author's name in the body of the chapter itself only when his work is referred to in some detail. Authors whose works are discussed at less length are referred to by key numbers directing attention to the numbered list references which follow each chapter. Many chapters contain in addition lists of general references which most students will find it profitable to examine. Since this is a general text these lists are for the student and not for the specialist. Case studies not otherwise cited are my own.

I wish to thank several of my good friends who were so kind as to read parts of the manuscript critically. Professor Harry F. Harlow spent much time over the chapters on the nervous system, on emotions, and on motivation. Dr. Hulsey Cason read the section on learning and memory. Dr. Neal Drought gave me many helpful suggestions on the early chapters which deal with the genetic antecedents of adult behavior. Professor Fred McKinney greatly improved the half-chapter on Mental Hygiene. Professors Kimball Young and Paul Farnsworth read and

PREFACE

vii

gave helpful suggestions on the material on the development of the personality. Mr. George Reeves did much to give the manuscript smoother expression. Mr. Robert W. Henning, an undergraduate student who read the entire manuscript before taking any course in psychology, gave me the benefit of a young layman's comments. My wife, Dorothy Anderson Husband, contributed a more mature layman's point of view and challenged me on many debatable points.

Madison, Wisconsin
April, 1940

R. W. H.

TABLE OF CONTENTS

PSYCHOLOGY AND ITS AIMS

- I. What Is Psychology? 3

GENETIC BACKGROUND

- II. Mental Evolution 21
III. Child Development 42

NEURAL AND SENSORY PROCESSES

- IV. Functions of the Brain and Nervous System 71
V. General Principles; Vision 86
VI. Audition and Contact Senses 112

MOTIVATION, EMOTIONS, AND PERSONALITY

- VII. Physiological and Social Motives 131
VIII. Practical Motivation 154
IX. Nature of Emotions 169
X. Acquisition and Control of Emotions 186
XI. The Nature and Measurement of Personality 210
XII. Development of the Personality 237
XIII. Deviations of the Personality 258

*TABLE OF CONTENTS***INDIVIDUAL DIFFERENCES AND INTELLIGENCE**

XIV. Individual Differences	299
XV. The Nature and Measurement of Intelligence	311
XVI. Educational and Vocational Guidance	338
XVII. Group Differences	349
XVIII. Heredity and Environment	381

LEARNING, MEMORY, AND THOUGHT

XIX. Learning	403
XX. Memory and Forgetting	436
XXI. Thinking and Reasoning	469
XXII. Unconscious and Automatic Processes	489
Index of Authors	505
Index of Subjects	509

ILLUSTRATIONS

1. Donald and Gua	24
2. Child and Chimpanzee Looking at Pictures	25
3. Gua's Table Manners	26
4. Donald and Gua Always Take the Same Positions in the Perambulator	26
5. Sultan Making a Double Stick	27
6. Grande Stacks Three Boxes and Reaches the Food	27
7. Diagram of Apparatus Used to Test Social Cooperation in Monkeys and Children	29
8. Examples of Cooperative Behavior in Chimpanzees	30
9. Problem Situations Used to Test Primates	34
10. Rat and Human Maze Patterns	36
11. Facial Expressions of the Koala Bear	37
12. Maturational Sequence	49
13. Curves of Maturation Showing Pecking Accuracy on the Part of Chickens	55
14. Connections Involved When One Sees a Bee About to Sting and Slaps It	73
15. Cerebrum and Spinal Cord	75
16. Vertical Transverse Section of the Human Brain	78
17. Lateral View of the Left Cerebral Hemisphere	78
18. Underside of the Human Brain	78

19. Cross Section of Human Right Eye	94
20. Typical Optical Defects	96
21. Eye-Movement Fixations in Reading	98
22. Müller-Lyer Illusion	100
23. Staircase Illusion	101
24. Applications of Principles of Illusion to Dress	102
25. Negative of a Well-known Historical Character	107
26. Development of an After-Image	108
27. Illustrating Auditory Localization	116
28. Diagram of Apparatus to Test Auditory Localization	118
29. The Pseudophone	118
30. Ground-Floor Plan of Obstruction Apparatus	136
31. The Effect of Introduction of Reward upon Learning	138
32. The Effect of Removal of Reward upon Learning	138
33. Facial Expressions during Emotion	182
34. Location of the Principal Glands Which Influence Behavior	240
35. A Normal Distribution and an Actual Distribution	303
36. A Bimodal Distribution	305
37. Three Sample Correlation Charts	306
38. Children's Drawings of a Man	329
39. Army Beta Test	333
40. A. Completion Tests	334
B. Maze Test	334
41. Relation between Aptitude Scores and College Grades	342
42. College Grades and Subsequent Salaries	346
43. Curves of Growth for Persons of Different Mental Levels	350
44. Maze Learning, Time	405
45. Improvement in Each Set of Five Trials on the Pursuit Rotor	405
46. Plateau in Learning Curve	406
47. Sudden Increase in Skill	409
48. Improvement in Learning Russian	410
49. Spread of Abilities with Practice	427
50. Curves of Retention for Various School Subjects	438
51. Curves of Forgetting During Sleep and Waking	452
52. Memory Curves for Learners of Various Ages	453

T A B L E S

1. Per Cent of College Students Who Hold the Misconceptions Indicated	11
2. The Medians and Quartile Ranges for Each Stage of Motor Development	50
3. Ages of Attaining Manual Manipulation Abilities	51
4. Samples of Developmental Norms	53
5. Comparisons of Dull, Average, and Bright Children in Ages of Attaining Motor Abilities	54
6. Size of Vocabulary of Preschool Children	62
7. Postural Responses in the Absence of the Cerebral Cortex	78
8. Loss of Habits in the Absence of the Cerebral Cortex	78
9. Visual Responses in the Absence of the Cerebral Cortex	78
10. List of Senses, with Their Subdivisions	88
11. Changes in Preferences of Foods	122
12. Numbers of Crossings for Various Incentives	137
13. Average Scores of Control, Praise, and Reproof Groups	147
14. Time Taken to Complete Problem Working Alone Compared with Two Working Together	151
15. Error Scores in Collective Maze Learning	151
16. Percentage of Children Who Showed Fear in Response to Various Experimental Fear Situations	188
17. Fears of Children Which Grew Out of Prior Fears	191

18. Samples of Ascendant and Submissive Traits	228
19. Distribution of Ranges of Capacities	301
20. Samples of Intercorrelations	309
21. Classification of IQ Levels	315
22. Educability of Various Levels of Intelligence	339
23. Approximate IQ's Necessary for Various Occupations	345
24. Scores of Salesmen Handling Different Types of Goods	345
25. Occupations of Fathers of Gifted Children	359
26. Intelligence Scores of Foreign Born in American Army	367
27. Intelligence Scores of Boys and Girls in High School	374
28. Average IQ's for Various Decades of Life	377
29. IQ Distribution of Parents and Children According to Occupational Class	384
30. The Relation between IQ and Parent's Occupation	385
31. Intelligence of Children According to the Occupational Status of Their Foster Fathers	387
32. Correlations of Intelligence Scores	387
33. IQ and Length of New York City Residence	389
34. Medians of Army Alpha Scores, White Soldiers	394
35. Effects of Coaching upon the IQ	395
36. Influence of Electrical Shocks upon the Speed of Maze Learning	417
37. Order-of-Merit Arrangement of the Various Degrees and Forms of Primacy, Recency, Frequency, and Vividness	433
38. Trend of Feelings toward Past Incidents	448
39. Relation between Speed of Learning and Quality of Retention in Maze Learning	460
40. Retention of Vocabulary Items	461
41. Most Important Characteristics of Inventors	481

PSYCHOLOGY AND ITS AIMS

I

WHAT IS PSYCHOLOGY?

1. The Field of Psychology

"The proper study of mankind is man," said Alexander Pope in the early 1700's. But it was not until almost two hundred years later that the science of psychology was born, and not until psychology began to employ scientific methods already familiar to chemists and physicists, that it could claim to be a *science*. How psychology became a science and what psychology has contributed to our understanding of human behavior is part of the story of this book. In studying psychology, we shall develop an understanding of what it can do for us: how it can modify and improve our behavior, and how it can aid us in attaining socially desirable goals. Psychology will broaden our knowledge of the forces that impel people to act as they do and deepen our appreciation of the manifold possibilities of living. Psychology is basic to an understanding of the world in which we live, for its subject is our world's most interesting inhabitant—man.

As a practical illustration, observe the interrelationships of law and psychology. Laws are designed to guide and to modify human behavior. They deal with reciprocal human relations and seek to prevent trouble by anticipating and attempting to control certain everyday situations. In forming a business partnership, future misunderstandings are avoided by means of a written contract. Wills often seek to control the future behavior of the beneficiaries. Criminal law attaches penalties to antisocial modes of conduct in the hope that the threat of punishment will deter crime. Civil law requires the payment of fines for infractions like speeding because otherwise some people would endanger the lives and property of their fellow men. The courts occasionally issue injunctions restraining persons or corporations from a continu-

ance of specified acts. All these restraints are necessary because men have not yet learned to live together in harmony. Laws in a democracy are based, theoretically at least, upon the "greatest good to the greatest number," but they are fallible instruments, always subject to change as human behavior changes.

When in this book we talk about motivation, emotions, personality, learning, memory, and thinking, we are not discussing some imaginary attributes of some imaginary person. We are discussing ways of motivating our associates, or, if we are engaged in business, our customers. We are trying to discover the basis of emotions we experience at one time or other. We are attempting to learn efficiently, to think accurately, and to understand the personalities of friends and associates. Our satisfaction in living is largely dependent upon how well we understand our fellow beings. We can learn to understand them better through a study of the general principles of psychology and their applications.

Even though psychology deals with everyday problems, it is far more than "organized common sense." Important as common sense is in the conduct of our affairs, we shall find that its practice often needs to be checked by the experimental method of science. Science is based upon the observation, not of an isolated act, but of hundreds and sometimes thousands of similar acts. Science is hesitant to formulate a general law until it has tested all possible exceptions to that law. Even then its conclusions are put forth tentatively and are always subject to revision. Psychology has been developed by the experimental method of science. In laboratories, classrooms, and factories psychologists have studied the principles upon which human action is based. Because it is possible to control the actions of animals to a degree impossible with human beings, they have often been used in experiments. Psychologists have learned much from doctors and physiologists, and have in turn contributed greatly to the understanding of man's physical make-up and to medical progress.

2. Definition of Psychology

Psychology studies *human behavior*. As a corollary, everything man does has psychological significance. "Know a man by his acts," is a well-known maxim, but this is not always the whole story. Man's acts include his response to environment, his ability to express and repress emotion; in fact, all the subtle variations of behavior of which man, most variable of all the animals, is capable.

In dealing with these variations of behavior we shall concern our-

selves primarily with the *normal adult human being*. In order to understand him better, however, we shall occasionally discuss animals, abnormal people, and children. Children are of particular interest to us, because so many adult actions may be explained by childhood experiences. Some adults are terror-stricken by elevators because in childhood they were confined in small closets for punishment. Others are prejudiced against red-haired persons because some redheaded boy who lived around the corner was a bully. One adult fears locomotives because he unconsciously associates them with the fire-breathing monsters in his childhood storybooks.

We are more interested in what people do and why they do it than we are in verbal justification, or "alibis." Intelligence and vocational competence are judged by what a person does or is able to do, rather than by what he says he does, intends to do, or hopes to do. This point of view differentiates modern psychology from the earlier "mental science," which emphasized the study of the soul or consciousness. Modern psychology is concerned with behavior that can be seen, demonstrated, and measured. There are vast areas of unexplored territory in the soul or consciousness, but until scientific methods of exploration are uncovered, psychology prefers to observe, record, and control behavior.

When behavior and verbal reports differ widely, observation is the best method of arriving at truth. For example, take the recent trial of several oil companies charged with regulating their prices in collusion. Although the companies vehemently denied the charge, for several years the price of gasoline in certain cities did not vary more than a tenth of a cent. The price even decreased or increased the same morning at the filling stations of all the companies. In the face of this behavior the evidence of collusion was overwhelming and the companies were heavily fined. Again, a politician promised for ten years that he would begin to reduce city expenses, but each year the budget was increased. Shall we believe him in the eleventh year when he campaigns with a "Reduce City Expenses" slogan? A student insisted that he was equally fond of classical and swing music. Yet his roommate never heard him listening to any but dance orchestras. If the roommate happened to turn on an opera or symphony, the dial was shifted to jazz the instant his back was turned. What were this student's real tastes?

Why does this student profess to like classical music, although he never listens to it? Why does a girl invent a suitor when she has none? In both cases there is undoubtedly compensation for feelings of inferiority and self-deception is employed to build self-esteem. Inferi-

ority feelings may often become factors in the development of a better personality, a subject which we shall investigate later.

3. Origins of Psychology

Psychology evolved out of man's insatiab^le curiosity about himself and his fellow beings. In that sense psychology has existed as long as man has inhabited the earth. Man is curious about all sorts of things: changing weather, growth of crops, the strange ways of animals, but most of all about himself. Primitive man speculated about dreams, death, sun and rain, the structure of minerals and stones, and how all these could be used to make him more at home in his environment. So that he might feel he was part of a larger scheme, he wanted to know things about himself. His science was rule of thumb. What has happened once may happen again, he reasoned. When he had seen how crudely the iron hatchet felled trees, he sought to fashion a more efficient ax. When he saw how marvelously land covered by the spring flood sprouted forth, he set out to devise an irrigation system. His psychology did not have a scientific basis, but in a groping way primitive man was learning about natural forces and his own capabilities and limitations. He was proud of his abilities: witness the animal drawings in the caves of southern France. He prayed to a supernatural power for the solution of his problems and limitations. The primitive man's psychology was practical; his observations and the conclusions he drew from them were adequate for his purposes. When society became more highly organized, the rule of thumb method was no longer feasible. Men began to look to the philosophers for guidance.

For centuries philosophers were the only psychologists: Plato, Aristotle, Galen, and Leibnitz were outstanding names of the early and middle periods of European civilization. Among others, the Englishmen Locke and Berkeley gave this field of learning great impetus. They were not interested in behavior as such, but rather in the soul and those functions we now call the higher mental processes. Their interest in psychology was incidental to what they considered to be the larger problem of man's destiny and his place in the order of things.

John Locke's *Essay Concerning Human Understanding*, published in 1690, was the first entire book on a psychological subject. Christian von Wolff, a German philosopher, is credited with using the word "psychology" for the first time in 1734. It is compounded from two Greek words and means literally "account of the soul." Although Locke and Wolff awakened their contemporaries to new truths about man, they did little to make psychology a science. The experimental

method was already well established in the natural sciences (Bacon, Galileo, Newton), but students hesitated to employ the same principles in the study of man. In the early 1800's a few experiments psychological in character were performed. These experiments were based upon physiology and physics rather than upon philosophy and theology, the traditional fountainheads of psychology. One of the first purely psychological measurements was unwittingly made in an English astronomical observatory. Two young men were assigned the task of observing certain stars passing a transit. They were to record their observations immediately. In doing so one of the men was always about half a second slower. The slower man was not stupid or careless; he had a slow "reaction time." We have all noticed that athletes differ in their reaction times. The margin between first and second place in a short race is often the split-second variation of response to the starter's gun.

Between 1840 and 1870 Weber and Fechner in Germany measured man's ability to discriminate weights, lengths of lines, and intensities of light. During the same period von Helmholtz was discovering the mechanisms of the eye and ear. In 1879, at the University of Leipzig, Wilhelm Wundt opened the first laboratory devoted entirely to psychological research. For many years Leipzig attracted scholars to its pioneer experiments in reaction time, sensory processes, and methods of introspection. Many leaders among American and British psychologists received training and inspiration from Wundt. These men were not concerned with the problems we consider most important today: intelligence, personality, the nature of learning—but a start had been made. Psychology had become a science, its inquiries based strictly upon observation and measurement.

Present-day psychology is related more closely to physiology, education, sociology, and anthropology than to philosophy. Biology has given us valuable data and physiology is, of course, basic to any study of behavior. Psychology becomes more important each year, because most of today's problems lie in the field of human relations. If we are preparing to teach, we need to understand individual differences, motivation, and the principles of learning. If we expect to enter the expanding fields of social welfare and government service, we must know something of group behavior and of the reactions of individuals in group situations. If we plan to go into business, our success will partly depend upon our knowledge of various types of human motivation. Every business and profession needs people who are trained in psychology. Increasingly we recognize the importance of human relations.

4. The Aims of Psychology

The purpose of any science is to *predict and control*, and this is true also of psychology. If we have enough facts in our possession, we can predict that under given circumstances a particular result will follow. If it is raining a few hundred miles to the west and an eastward wind is blowing, the weather bureau will predict rain for tomorrow. Because of the wealth of information at their command, the predictions of weather bureau experts are remarkably accurate, despite jests to the contrary. Similarly, the engineer knows what thickness of beam to install in a bridge to carry weights of five tons or fifty tons. And the psychologist can estimate with accuracy the minimal intelligence score necessary to complete high school or college, or to succeed in law or medicine.

Next comes the task of control. After we have collected enough facts and data so that we can generalize with reasonable accuracy, we apply our findings. We postpone plans for a picnic if rain is imminent. The engineer designs his structure so that it will hold up under the expected load and he allows a certain margin for safety. The psychologist may urge the parents of a bright child to send him to college, and he may suggest that a child who is mediocre in scholastic aptitude be sent to a vocational school, rather than risk failure in an endeavor for which his abilities are inadequate.

Accurate prediction demands a formula. Physics, chemistry, and engineering use many formulae; but psychology is still less exact than these fields, because human behavior is more complex and less easy to predict than the reactions of physical or chemical substances. Yet this does not mean that psychology is too uncertain to be of practical value. Also, it is important to note that the psychologist usually takes the whole individual as his unit, while the physicist deals with a group of atoms. The physicist has found that after 1,580 years only half of any given quantity of radium will remain, but he cannot say which particular particles will have been cast off. Similarly, life insurance tables tell us how many men out of a hundred, now twenty years of age, will still be alive thirty years hence, but do not list the names of the survivors.

In certain instances, however, the psychologist can predict more accurately than the physicist or actuary. For example, at the University of Wisconsin about two thousand freshmen enter the Arts College each year. By means of a formula employing high school grades and intelligence scores, it is predicted with surprising accuracy just how well each student will do in college. More than nine-tenths of those for whom failure is predicted do fail, and the great majority of those for whom

success is predicted make satisfactory college students. These predictions are not restricted to numbers or to averages. Instead of merely stating that two hundred are going to fail, the psychologist can name the likely failures.

5. Variables in Behavior

Here are some of the variables that cause us to say that it is more difficult to predict the behavior of an individual than of a physical object. In these and many other ways we as human beings differ from electricity or oxygen, one unit of which is exactly like every other unit.

(A) **PHYSICAL CONSTITUTION.** A tall, well-built man may have a different outlook on life than a small, thin man. Similarly, a man's health, energy, and possible physical defects have a definite effect upon his behavior.

(B) **PHYSICAL CONDITION AT THE MOMENT.** Physical condition colors reactions. If a person feels well, he is likely to agree to a plan requiring an expenditure of energy. If he is tired or has a headache, he will be much more difficult to motivate.

(C) **PERSONALITY.** We differ from one another in our likes, dislikes, interests, and outlooks. One person prefers music, a second baseball, a third Russian literature. One becomes angry at slight cause; another remains bland under real provocation.

(D) **PAST EXPERIENCE.** "The burned child shuns the fire" is a truism. After a man has been injured in an automobile accident, he may be afraid to drive at high speeds. A man who has been disciplined in boyhood may be more exacting in business than one who has been pampered in early life.

(E) **INTENTIONS.** The student who intends to go to medical school will in general study more regularly, show more interest, and be less susceptible to social distractions than the one with less definite intentions. The average student in a college of commerce works harder on courses which promise to be of practical use than on those which are purely theoretical. Temporary intentions likewise influence behavior. One who has made up his mind to play golf may refuse to play tennis even though he ordinarily enjoys the latter.

(F) **ENVIRONMENT.** We adapt conversation and action to our associates of the moment. A minister, a maiden aunt, a potential employer, a desirable member of the opposite sex, all get different impressions of us.

SUMMARY. These variables lead us to two main conclusions: (1) people differ from one another; (2) each of us differs from time to time in his own behavior.

In spite of the complexities that these factors introduce, study of psychology is not in vain; rather, its complexities provide endless fascination. Even if we cannot make absolutely exact predictions of behavior, a study of the general principles will help us greatly in understanding ourselves and in dealing with other people.

Psychology will help us to understand our friends' personalities better and to be more tolerant of their opinions and idiosyncrasies. It will help us to regulate our emotions, to learn more effectively, think more clearly, avoid some of the errors made by people with untrained minds, and become well-adjusted social beings.

6. What Psychology Is Not

Questions asked of psychologists at social gatherings indicate that misconceptions are prevalent concerning the subject matter of psychology. The psychologist may be asked to read minds, to hypnotize one of the persons present, to guess another's intelligence from looking at him or his photograph, to advise a vocation after a few minutes of conversation, or to conduct a spiritualistic séance. Let us, then, consider briefly some of the topics which do *not* fall within the precincts of psychology. So far in this chapter we have been outlining its legitimate contents.

Reading a person's mind is not possible, for which we can often be thankful! Of course, one can often recognize by external symptoms that an individual has something on his mind. Occasionally a student comes into my office, haltingly inquires about his grade or his future courses, starts for the door, hesitates, fidgets, returns and asks another irrelevant question. I usually say, "All right, tell me just what it is that is worrying you." He is obviously concerned about something, but whether it is school work, finances, social problems, or home worries, I cannot say.

Scientists refuse to accept any foundation whatsoever for spiritualism. While some clever stage feats have been performed, no medium has been able to produce any of the purported phenomena in a laboratory, with conditions controlled, and without the accompanying hocus-pocus which serves more to conceal what is being done and to confuse the observer than to provide the "spirits" with a favorable setting.

Hypnosis is a genuine psychological phenomenon, but it is, so far at least, of little practical importance. Efforts have been made to utilize hypnosis in medicine and in psychiatry, but for the most part the method has been abandoned. The great majority of psychologists never have anything to do with experiments in hypnosis.

Intelligence can be measured only by means of a test, not by looking

at a person, examining a photograph, talking with him casually for a few minutes, or by hearing at second hand the bright sayings of a child. Similarly, vocational guidance is given only after thoroughly testing an individual, studying his personality traits in great detail, talking with him at length about his interests and ambitions, and matching all these with the responsibilities and opportunities of the projected occupation.

Many persons are afraid to walk through a pasture if they are wearing a red sweater, or even a red tie or scarf. Yet actually bulls are totally color-blind! Their rage is inspired by movements and threatening gestures. Likewise, our household pets, dogs and cats, are color-blind. Some of you may say, "Maybe most are, but mine is different. He just loves to play with a red ball." Doubtless he does, but did you ever try him with a blue or a green ball of the same color intensity?

The fallacies discussed above seem obvious enough, and you may be thinking that you have never believed any such nonsense. Yet many college students, who should represent the most intelligent group of the population, believe in these or similar fallacies. Valentine, making a survey of the beliefs of over fourteen hundred students at Ohio State University, [1]¹ found evidence of all the misconceptions shown in Table 1. Startling as these may be, it is probable that even more superstitions are held than are admitted. Only a few students confessed frankly that they felt Friday was an unlucky day or that thirteen was an unlucky number. Yet, in actual behavior, many of them would refuse to start on a trip or begin a new enterprise on Friday. Many educated people hesitate to risk having thirteen guests at a dinner, to wear the number 13 on an athletic jersey, to rent apartment number

TABLE 1
PER CENT OF COLLEGE STUDENTS WHO HOLD THE MISCONCEPTIONS INDICATED

Fallacy	Men	Women	Total
Chess playing develops concentration.....	81%	75%	79%
Mathematics gives us a logical mind.....	70	73	72
Psychology can pick job best fitted for.....	62	74	67
Red especially exciting to cattle.....	60	67	63
Children learn faster than adults.....	57	67	61
Primitive people have keener senses.....	61	56	58
Man has only five senses.....	57	59	58
Persons may be caused to perform criminal acts while hypnotized	55	53	54
Majority of criminals very low in intelligence.....	56	51	54
Mothers intuitively know child care.....	49	53	51

¹These numbers in brackets throughout the book refer to the exact original sources listed at the end of each chapter.

13 or an office on the thirteenth floor. In many buildings when rooms and floors are numbered, 13 is omitted.

Thus, we observe an important fact of psychology: people tend to say one thing but to indicate by actual behavior that they feel another. Which is correct—what a person says or what he does? If he declares that the superstition about 13 is foolish, but at the same time will not live in room 13, has he not in truth swallowed that fallacy?

In addition to the fallacies quoted in Table 1, certain other equally erroneous beliefs were accepted by more than a quarter of these college students. Some of them were: women possess intuition; there is an innate urge to jump from high places; a hypnotized person is weak-minded; most great men were born of poor but honest parents; a person's intelligence may be estimated by looking at his face.

In the following chapters we shall from time to time quote direct or indirect evidence to show just why certain of these statements are fallacious. It is generally true that scientifically controlled data from a large number of cases, gathered under controlled conditions, give a truer answer to a question than does the opinion of one person. Yet, we always find a certain number of people who object to any psychological rule, saying that they know better and that they will keep their "tried and true" beliefs. Their beliefs may have been tried, but often they are not true, since they have not been subjected to statistical proof. In fact, psychological experimentation has disproved many time-worn proverbs, such as "Practice makes perfect" or "Two heads are better than one." For instance, "slow but sure" has been said so often that most of us believe it to be true. Actual experimentation, however, has shown that with rare exceptions those persons who work rapidly make fewer, rather than more, mistakes; that those who are able to learn rapidly also remember longer; and, conversely, that slow readers are less accurate and forget more during a given period of time.

Even long experience is not necessarily productive of accurate judgments. Employers have so generally thought they could judge intelligence from the face, in person or photograph, that the idea is widely accepted without challenge. But when this supposition was subjected to experimental verification, it was completely and thoroughly exploded. Consequently, before accepting ready-made conclusions, one should demand statistical proof of positive and negative cases, honestly and impartially obtained.

7. Methods of Psychology

How does the psychologist go about his task? How does he obtain his data? How does he get the facts that he uses in formulating laws

and general principles? There are several general approaches, and we shall inspect each.

(A) COMMON-SENSE OR RATIONAL. In using this approach to psychological knowledge, one considers how people ought to behave. For example, it is frequently stated that certain boys' organizations reduce juvenile delinquency. Regardless of how reasonable this may sound, in one city, when boys of the same age and social class were compared, it was found that virtually as many club members as non-members fell into trouble. Much planning of advertising campaigns is on the same rational level. An advertiser tries to decide what appeal should sell the most goods. He may be right, or he may waste thousands of dollars. Such guesswork methods are now being supplanted by fact-finding surveys. Highway safety engineering has faced similar problems. At one time it was thought that the more stop signs were placed the more safety would be promoted. But actual experience showed that an oversupply of signs led to disregard of warnings and more accidents. Cutting the number of signs in half actually decreased accidents in some cities.

One serious difficulty with the common-sense approach is that it often becomes anecdotal, that is, it generalizes without sufficient data. A person will quote one or two experiences and interpret them as general laws or truths. But he may be far from the truth. Virtually every child is superior, if we are to credit tales of its parents. Occasional bright remarks are repeated and generalized upon as if they were everyday occurrences. Yet the child may have repeated something he heard an adult say, or his parents may have coached him, or this bit of behavior may have been exceptional, just as once in a while the duffer makes a remarkable golf shot.

Notice that we do not deny the occurrence of the incident. The child may have made an unusually bright remark, and the mediocre golfer may have been a stroke under par for a single hole. It is in the explanation and interpretation of such facts that we often go astray. Did the child think up the remark by himself? The critical question is this: Is either instance of superiority typical or is it merely a single unusual bit of behavior?

The earliest psychological writings were contributed by philosophers. Naturally, their methods and treatments were far different from those used today, since psychology at that time had not become a laboratory science employing experimentation and statistics. These philosophers used the method known as *introspection*. That is to say, they observed their own mental processes and described them, often in terms of three divisions: sensation, images, and feelings. Introspection has been criti-

cized on the basis that it deals with trivial and inconsequential matters instead of with actual daily behavior, that it is individual and private and hence not applicable to everyone, that it is especially open to prejudice and distortion, that it is not subject to scientific measurement, and that thinking about one's own mental processes divides the attention and therefore alters what one is studying. Introspection has its uses, however, in several important fields of behavior. We shall see how it may be applied when we study emotions, sensations, and thought processes.

(B) **OBSERVATIONAL, OR EMPIRICAL.** The observational method is an objective one, whereas introspection is subjective. An *objective* fact is one which can be measured, recorded, or observed by an outside person. An intelligence test is objective, because it requires written or spoken answers, and these can be checked for accuracy. The length of time a student requires to learn a sixteen-line poem is also objective, since it may be measured in terms of minutes and seconds. But your emotion, your day-dream, or your opinion of a necktie is *subjective*. You can keep such feelings to yourself, and no one can verify your honesty in reporting them.

To return to the *observational* method—we watch people or animals do things and then we report our findings, perhaps by presenting a statistical summary. For example, we see how many times a child reaches for his toy with his right hand and how many times he uses his left. Or we watch the behavior of an insane patient who is not aware that he is being observed.

✓ The *genetic* and *case study* methods fall under this heading. In them, one watches the behavior of an individual over a period of time, just as a physician may keep a patient under observation for several weeks before deciding what treatment is desirable. The term "genetic" usually applies to the study of behavior of children as they develop. Thus, one can study the development of locomotion over many months or the acquisition of vocabulary over a period of years. { The case study method is similar, but usually applies to a concentrated study of the adult over a period of time. For example, we observe an abnormal patient for several weeks to determine whether he has dementia praecox or manic-depressive psychosis. Or we may carefully observe a factory workman for days or weeks, and study his entire record as well, to ascertain whether he demonstrates the necessary characteristics of leadership sufficiently to warrant promotion to the more responsible position of plant superintendent.

Everything learned through the observational method is correct and true, but the method has its limitations. Its chief advantage is that it

studies behavior under normal, natural conditions. However, these conditions are often likely to be complex, so that one cannot be certain just what is the exact cause of the observed effect. All the variables present in the original situation are still there. Therefore we prefer to use the experimental method.

(C) **EXPERIMENTAL METHOD.** This is the strictly scientific approach. Usually we study our problem in the laboratory, where we can eliminate all disturbing factors. Human behavior contains a great many variables, and unless we can eliminate some of them, we cannot identify true cause-and-effect relationships.

There are two main ways of doing this: (1) by excluding as many as possible of these extraneous variables; (2) by keeping all factors constant except one. Let us give an example of each.

To illustrate elimination of extraneous variables, take a simple experiment for accuracy of auditory localization. The *subject* (person on whom we are experimenting) goes into a soundproof room, insulated so that no sounds can penetrate from building or street. Buzzers, all tuned to the same pitch, are hidden so that the source of sound cannot be seen. They are sounded in random order, so that the subject cannot anticipate the direction of the next sound. In other words, the subject is limited to one cue—the sound alone.

As an example of the method of keeping factors constant, suppose we want to discover how much faster school children will learn spelling if we praise them than if we accept their work without comment. We divide the class into two halves, one of which, the "experimental" group, is commended at every opportunity, while the other, the "control" group receives neither praise nor blame for its efforts. As a further precaution we pair each person in one group with an individual of equal probable ability—the same age, grade, school marks, intelligence score, and home background—in the other. With both groups equal, we have in effect eliminated all but the single experimental factor.

In an experiment testing the effects of drugs, the experimental group is administered the drug and then required to perform certain tasks, while the control group carries out the same tasks in a normal physiological state. All factors but one—the drug—are constant.

These methods, where variables are either eliminated or kept constant, are the same that we use in solving simultaneous equations in algebra. We have equations like these:

$$\begin{aligned} 3x + 2y - z &= 8 \\ x - 2y + 3z &= 8 \\ 2x - y + 2z &= 9 \end{aligned}$$

We reduce them by appropriate addition, multiplication, and subtraction, thus getting rid of the y variable. Then we have :

$$\begin{aligned} 4x + 2z &= 16 \\ 7x + 3z &= 26 \end{aligned}$$

Which in turn reduces to $-2x = -4$. By substitution we find that $x = 2, y = 3, z = 4$.

In our example of measuring the influence of praise we have tentative equations like this :

Case A. 12 years age + intelligence score of 105 + 90 average in school + a home of medium culture + being praised = arithmetic score of 84.

Case B. 12 years + intelligence score of 105 + 90 average in school + a home of medium culture + no praise = arithmetic score of 76.

Since all variables but the last are the same in both cases, we are reasonably safe in concluding that the praise was responsible for the second boy getting 8 per cent higher marks in arithmetic.

Let us emphasize strongly the necessity of proper scientific controls. Recently, a psychological investigator attracted considerable attention with experiments which he claimed proved the existence of "extra-sensory perception." [3] That is, certain individuals are said to possess the ability to obtain certain information by means other than the usual sensory channels of the eye, the ear, and so on. The customary task assigned was to call off the designs printed on cards, with the pack face down. As there were five different geometrical forms, 20 per cent accuracy would be considered chance, and any accuracy above this taken as evidence of extra-sensory perception. In this original study certain individuals made fairly consistent scores well above chance accuracy. Occasionally more than twenty of the twenty-five cards were called correctly. Sometimes even individuals in cities over a hundred miles away, working simultaneously with the experimenter, who remained at the home base, made high scores.

But in a number of other universities carefully controlled studies failed to furnish any evidence whatsoever of extra-sensory perception, and the investigators were convinced that there were some loopholes in the original methods. Let us mention a few such possibilities, which may be pertinent in this case. [2, 5]

(1) As a general proposition, the more carefully controlled the study, the greater likelihood there is of chance percentages. Informal condi-

tions tend to relax the experimenter's caution as well as to provide the subject with more friendly surroundings. (2) Individuals have varying degrees of success; some make extraordinary scores while others fail to make even average scores. While this is not an insurmountable objection, it does arouse suspicion. We wonder why one person possesses a mysterious ability that is denied to the rest of us. (3) Not all results are reported. One is reminded of the boy who tosses a coin until it comes down heads, then goes to the movie instead of studying. (4) Recording errors occur occasionally, even without complicity, when the experimenter wants to hear a certain answer. (5) Rational inference might help. In certain card games (e.g., blackjack or 21) one may guess the next card with better than chance accuracy by noting whether the last few have been high or low. Likewise, in the present situation one might call "circle" because a circle has not appeared among the last several cards. (6) The fact that the majority of positive results were found in one laboratory makes one suspicious that one or more extraneous cues remained uncontrolled. (7) It is quite possible that the subject received cues, probably unknown both to himself and to the experimenter.

This last point is worthy of expansion. Subliminal (not consciously recognized) visual or auditory cues are often of aid in guessing. The writer has seen a pack of cards specially prepared for the experiments described above. A slight depression remained on the back of each card after the ink had dried, and, by watching these closely, it was possible to call every single figure—not just a few more than the five chance would dictate—if the pack was placed so that light reflected upon it. If the subject's back is turned, the experimenter's voice may occasionally provide a cue. Either the subject or the experimenter should be screened or placed in a soundproof room, and the voice or sound telling the subject to make his choice should be presented in a manner so automatic that there is no possibility of human variability. To show how minute cues may be picked up, we cite evidence from a careful experiment conducted by Coover at Stanford University.[1] Without notifying the subjects beforehand, he gave them minor cues by allowing playing cards to be reflected from his glasses, or by whispering, too low to be heard, the name of the card. He was thus able to produce in his subjects better than chance accuracy. In other words, it is quite probable that the success certain subjects had was due to cues that came through recognized sensory channels and not through "extra-sensory" modes of communication. Some subjects are better than others in picking up these faint stimuli, just as some people can understand faint radio signals unheard by others.

We conclude that the ability to derive extra-sensory perceptions—if it exists at all—is present only in some people, in them only part of the time, and there is far from perfect thought transference even then. This last point is of practical importance. It is much simpler to call off geometrical designs on a card than to transfer definite and complex thoughts such as “Meet me in front of Smith’s at two-thirty tomorrow afternoon” or “Bring home two pounds of steak tonight.”

SUMMARY

Psychology studies human behavior. So far as possible we prefer to accept the evidence of actual behavior rather than statements or introspections.

The aim of psychology, like that of other sciences, is to predict and control. We have so many more variables in our field than in the physical sciences that prediction as yet is far from accurate. The two chief variables are differences between individuals and changes within any single individual from time to time.

The most satisfactory approach is the experimental method. By it we are enabled to ascertain exact causes and to arrive at a more precise solution to our problem. We may have an hypothesis—say that fast learners also forget rapidly or that women are more emotional than men—that we wish to test. It may be verified or disproved by actual testing, provided the group tested is sufficiently large to offset exceptions as well as errors in testing. Conclusions derived from reason (common sense) or through introspection are subject to limitations. The observational method gives us facts and is a necessary procedure with some topics, but it too has certain drawbacks. Therefore, the critical thinker will insist that a problem is not finally solved until it has been tested under properly controlled experimental conditions.

REFERENCES

1. Coover, J. E. Experiments in psychical research. Stanford University Calif.: Stanford Univ. Press, 1917.
2. Kennedy, J. L. A methodological review of extra-sensory perception. *Psychol. Bull.*, 1939, 36, 59–103.
3. Rhine, J. B. New frontiers of the mind. New York: Farrar & Rinehart, 1937.
4. Valentine, W. L. Common misconceptions of college students. *J. appl. Psychol.*, 1936, 20, 638–658.
5. Wolfe, D. A review of the work of extra-sensory perception. *Amer. J. Psychiat.*, 1938, 94, 943–955.

GENETIC BACKGROUND

II

MENTAL EVOLUTION

1 The Genetic Viewpoint¹

All the abilities and all the knowledge that we now have or ever will have arise from three sources: (1) Innate equipment, which includes both inherited and congenital traits; (2) prenatal and postnatal development: grasping, locomotion, sex maturity; (3) learning, the process of acquiring habits, knowledge, and skills that goes on throughout life. When we survey the behavior of man as he becomes educated, mingles in society, and conducts business we shall see that learning is by far the most important of these three.

Everyone of us learns, develops, and changes during his whole life. We never stand still. The child grows rapidly both physically and mentally. In the first years the foundation of habits and personality traits is laid. Thereafter, as he matures, he constantly acquires new abilities and new items of knowledge. The adult gains experience and wisdom throughout his long maturity, even though he is no longer growing physically.

Hence we cannot discuss behavior without inquiring into its antecedents. One may be reliable and punctual because his parents always insisted on it. Another person may be a criminal because he was brought up in the slums or orphaned at an early age. A student may fail in college not because of lack of ability, but because he has never formed efficient study habits. So, to understand more about the adult, we must find out what his birth equipment was, what development has occurred since birth, and what learning has taken place during his life.

¹This section enunciates a consistent viewpoint which will be adopted toward all topics throughout the book. The reader is urged to understand thoroughly its implications before going on.

For these reasons it is desirable to approach the study of psychology from the genetic viewpoint. This viewpoint emphasizes development, growth, and learning. We intend to follow it throughout the book. In the next two chapters we shall briefly discuss animal and child behavior, tracing mental evolution and the individual growth which lead to the human adult. Subsequently, when we consider personality, emotions, intelligence, and thought, we shall always treat these processes as they grow from childhood levels into adult traits and capacities.

To consider the whole genetic field we must look back even beyond the child. Our ancestry reverts thousands of generations to simpler and simpler men, until a transition stage is reached where we consider the species as subhuman. These ancestors of perhaps a million years ago resembled our present-day apes and monkeys. Although none exactly like them is alive today, we can ascertain with reasonable approximation the progress of the human race by studying the differences between man and present-day animals.

2. Mental Evolution

Man is very much interested in animals, both from curiosity and for practical use. Witness the huge crowds at the city zoos. The "monkey house" is always popular. Can it be that people exhibit such interest in the behavior of primates because they see themselves and their friends caricatured? The upright posture, the use of the forelimbs as hands rather than solely for walking as in the quadrupeds, and the obvious ability to reason suggest a greater resemblance to human beings than to animals of subprimate levels.

Scientific interest in animals was greatly stimulated toward the end of the nineteenth century by the publication of Darwin's theory of evolution. Darwin postulated a biological, or structural, evolution of living species, from the lowest single-celled creature upward to man. The essence of his theory was that organisms have developed continuously, and that development has been toward ever more complex forms as the centuries have rolled by. This theory opposed the previous assumption of independently created species, separate and distinct from each other. In terms of Darwin's theory, it is quite likely that if land life were wiped from the face of the earth, evolution would reproduce in largely similar form the same species as are now existent. Noah's Ark was unnecessary, except to save a few million years!

By way of illustration let us trace the development of two different organs. The arms of man are parallel in structure to the front fins of fish, the wings of birds, and the forelegs of quadrupeds. All these paired organs arise in individual development from similar embryonic

rudiments of bone, nerve, and muscle. Similarly, the nervous system has the same fundamental elements in man and the higher animals. The brain of an ape, or of a smaller monkey, contains the same structural parts as our own. Ours is larger, the cerebrum is especially well developed, but the same major parts are present in both. Even the rat has largely the same parts as man. But below the mammal level major differences are found.

Well then, several scholars have argued, if we have evolution of parts of the body, why not a similar mental evolution? Unfortunately Darwin's theory was extended too far and it was assumed that when he said animals represented one continuous line leading up to man he meant that the various species must have the same mental capacities, in some cases even to the same degree. As a result, we heard astonishing tales about the achievements of various animals, many of them comparatively low in the evolutionary scale. Dogs, cats, horses, and birds were supposed to be able to talk, understand language, count, and discriminate between colors.

We have now become much more critical in our thinking, and these early fables concerning remarkable animal behavior have been discredited. But we are still much interested in the problem of mental evolution.

The assumption that human beings are at the top of the scale—they are especially superior in speech and in problem solving tasks—does not imply that we are better at everything. We cannot climb trees like monkeys or cats, or follow a scent like a bloodhound, or run as fast as a deer, or jump as far or as high in relation to our size as the grasshopper. But these are all simple sensory and motor tasks, and not intellectual ones.

Again, when we say that a man or an animal is superior in a certain function, we also want to know the degree of superiority.

To begin with, the problem of telling just how much man may be superior to certain animals is not simple. Without language, many tests are difficult to administer; and obviously, in testing animals we cannot employ tests using words. Further, it is difficult to find suitable apparatus for testing all species. A test that demands the use of hands for manipulation is fair to a human being or a monkey, but would be manifestly unfair to a dog or a crab.

3. Animals in a Human Environment

(A) "THE CHILD AND THE APE." One of the most interesting and spectacular experiments ever attempted in psychology was that per-

formed by Dr. W. N. and Mrs. L. A. Kellogg. [11]² In their household in Florida they raised their own son and a young female chimpanzee, as if both were their own children. The child was ten months old when the experiment was begun; the chimpanzee seven and a half months.

The purpose of the experiment was to see what similarities and what differences there might be between these two "children" if they were treated and raised alike. The Kelloggs insist that the usual comparisons are measures not merely of innate capacities but also of the effect of environmental influences. Instead of keeping the ape in a cage, or perhaps chained in the back yard, the Kelloggs decided to raise Donald and Gua together as brother and sister, under exactly the same conditions. The chimpanzee wore diapers and, later, rompers and shoes, at the table she sat in a high chair and used dishes and a drinking glass, slept in a bed. Observations and tests proceeded continuously for a period of nine months. The Kelloggs refrained from trying to see how much the chimpanzee could be made to learn; this was an experiment, not a stunt or circus performance.

(1) *Physical comparisons* are interesting. It is apparent that anthropoids (the higher apes, not the smaller monkeys one sees in zoos or with organ grinders) are closer to man than they are to the other animals. The skeleton is largely the same, with two major differences in proportion which somewhat influence behavior: (1) the legs are shorter and the knees are slightly bent, making upright walking less easy; the arms are longer and the thumb is not placed quite so conveniently for making delicate movements; (2) also the skull is smaller and recedes from the eyebrow line, which means a smaller brain and a much smaller frontal lobe. Body temperature, blood, and other items of body chemistry, and habits of eating and sleeping, are largely like those of man.

(2) *Walking*. In the development of walking Gua showed marked effects from being brought up in a human environment. The usual mode of locomotion in the higher apes is a half walk and a half four-footed gait. While in the semi-upright position, apes often use the backs of their fingers as supports or crutches. At eight and a half months Gua could run rapidly and gracefully, but on all fours. About this same time she could walk in an upright posture, holding onto Mr. Kellogg's hand or his trousers as he walked slowly. At nine and a half months she stood or walked upright more than half the time. An interesting contrast is noted in the mode of upright locomotion; the

²Kellogg, W. N. and L. A. The ape and the child. New York: McGraw-Hill Book Co., Inc., 1933.



FIG. 1.—Donald and Gua.
(From Kellogg.)



FIG. 2.—Both Donald and Gua are able to point out familiar objects in their picture books.

chimp holds the hands upstretched, much like a tight-rope walker. After this stage Gua surpassed the usual development of her species; she began to walk with arms at her sides, even occasionally stooping over to pick up an object without pausing. This is a greater achievement than it appears, since the ape underwent the additional handicap of wearing child's shoes.

(3) *Motor abilities.* The chimp matured much faster than the child in such acts as climbing and jumping. She could retain her balance in climbing into a high chair from almost any angle, side or back, rather than just from the front as did the boy. On the other hand, the boy did as well, or even better, at more delicate manual acts, such as picking up a coin from the floor. Structural limitations largely accounted for this, since the chimp's thumb is located farther up the wrist and the fingers are longer, thus making a pinching motion difficult.

(4) *Sensory tests.* Both "children" showed just about the same abilities in vision, audition, and other senses. An interesting difference in the use (as distinguished from sheer capacity) of one sense is the fact that Gua failed to identify people by their faces, although tests showed that her vision, color discrimination, and judgment of distance were as good as Donald's. At the outset she often failed to identify people until she smelled them. Later she learned to spot them by their clothes, but frequently failed to recognize them if they changed their clothes or appeared in a new dress or suit. This corresponds to an adult's failure to recognize a person in street clothes after having met him in evening attire or in a bathing suit. Both Donald and Gua showed about the same behavior in looking at a child's book of colored pictures, and both were fooled by the two-dimensional space; they tried to pick up objects from the page.

(5) *Social behavior,* arbitrarily, might be presupposed to bring out greater differences, since it is usually thought to be of a higher type than the functions we have just discussed. But in their play, both alone and with each other, and in their behavior toward their "parents," there was an essential similarity. They both played in a sand pile, letting the sand trickle through their fingers. They sat with their legs spread wide, and rolled a ball back and forth. They chased each other around. Gua usually enticing Donald to run after her. When they were wheeled in a perambulator the ape always took the same place—at the back near the handle, while the child rode backwards. The two got along together splendidly, playing in a perfectly natural manner.

Behavior toward the Kelloggs showed similar emotional attachments. They both kissed their "parents" frequently, and enjoyed being hugged or hugging. Gua seemed to miss them more when they

were absent and often raised quite a fuss when they left the house. She was also loyal in defending the preferred parent, Dr. Kellogg, from a pretended attack by Mrs. Kellogg.

(6) *Intelligent acts.* The chimp acquired many of these earlier than the child. She became able to eat with a spoon and drink from a glass at an earlier age, and performed these acts without spilling. She learned to use a doorknob before the boy did.

In problem solving, sometimes one was better and sometimes the other. The chimp was a little better in pulling a chair underneath a suspended cookie and climbing up to reach it, but the child was quicker in adjusting to a detour—in returning to the parents through a farther door when the nearest and straightest route was blocked off. They were about equal in realizing that a hoe could be used to pull in a desired object lying at a distance farther than they could reach.

Likewise, stupid behavior of a similar nature was exhibited by both. Donald tried to pick up objects which were under one wheel of his pusher or even under his foot. Gua got her fingers caught behind a slanting board and did not seem to realize that as long as she kept her weight on the board she could not get loose.

The ape sometimes amused herself by tracing designs with her finger in the moisture on the windowpane when she happened to breathe upon it. How many of us have done the same thing!

One important difference was that Gua did not keep her attention on any single activity for as long a time as did Donald. This same difference obtains between bright and dull human beings.

(7) *Language* marks the greatest difference between animals and man. We know that no animal possesses real speech, let alone written symbols. Animals may communicate meaning through snarls and calls, but these are probably more in the nature of emotional expressions of feelings within the animal than for the purpose of direct communication.

Yet we also recognize that many animals can learn to *understand* a certain number of words. Horses obey a few verbal commands, and dogs can form some associations. Parrots can be taught to say several words, although stories of their appropriate remarks are highly exaggerated. There is an important physiological reason why a chimpanzee cannot learn to speak. He is lacking in Broca's area, which controls motor speech. If Broca's area were removed from a human being he could no longer talk, although he could understand what others said and he could read and write. (For location of Broca's area see chart on page 78.)

Gua was able to learn many words and phrases, and to obey com-



FIG. 3.—Few children of this age could handle a spoon as well as Gua does.
FIG. 4.—Donald and Gua always take the same positions in the perambulator.



FIG. 5.—(*upper right*) Sultan making a double stick.

The chimpanzee succeeds without undue difficulty in putting two sticks together in order to make a single longer one. (From Köhler, p. 132.)

FIG. 6.—Grande has piled three boxes and reached the food goal—a banana suspended in the air.

Note Sultan's left hand extended upward as if to help. Such an action is called "empathy." (From Köhler, p. 142.)

mands they contained. At the end of the experiment she had a vocabulary of 95 such words and phrases, while Donald could respond to 107—practically equality. The chimp would act on such orders as, “Kiss Donald”; “Shake hands”; “Take it to Mama”; and “Show me your nose.”

(8) *Adaptation to environment.* A question of great interest is this: To what extent could the chimpanzee fit into a civilized environment? Could she be successfully housebroken? When the experiment was concluded neither subject was entirely safe from accidents away from the toilet, although the boy had developed greater control. The Kelloggs point out, however, that this may not be a genuine difference in response to training. All primates are easily upset emotionally, and urinate when surprised or frightened. Gua had made a lot of progress and used the toilet most of the time. Also, after an accident she displayed unmistakable guilty behavior, which implies a certain degree of conscience.

An amusing incident occurred one day when Dr. Kellogg wished to do some work and Gua kept trying to climb into his lap. After a while he ordered her to remain seated on a stool across the room. This she did for a time, but was obviously distressed at being so far from him. Finally she climbed down, pushed her chair over next to his, climbed up again and remained quiet. She had solved the problem to her complete satisfaction; she could be near her “father,” yet still obey him.

Throughout this description the essential similarity of the behavior of the two organisms has stood out. Up to the age of a year and a half, at least, the child and the chimpanzee show roughly equal status in problem solving, in sensory acuities, and in emotional behavior—a demonstration that there is no qualitative gap between human beings and anthropoid apes. In fact, except for ability to use language for communicative purposes, the young human child is in no important way any more advanced than is the chimpanzee of the same age.

(9) *Summary and evaluation.* By this time the critical reader may have said to himself, “Your experimentation may be all right; but it is obvious to anyone that a chimp is well below man’s abilities.” True enough. The crux of the whole situation lies in the fact that the study was conducted while both the child and the chimpanzee were still growing, and neither was near maturity. Puberty in such anthropoids as Gua occurs at about four years, in contrast to approximately thirteen in the human being, so at any given age the chimp was much closer to his ultimate limits of development.

Another crucial fact is that an ape is born more fully developed. The human infant is quite helpless at the time of birth. This period of help-

lessness is much shorter and often absent in the lower animals. This accounts for the faster rate of development of the chimpanzee along certain lines, especially in motor coordination.

If the experiment could have been continued a year or two longer, there is no question that the child would have left the chimpanzee far behind. Especially would this be true in problem solving and in the use of language forms. A close analysis of the findings in this experiment shows that in intellectual abilities the child was catching up to and rapidly passing the ape in the later months of testing.

At the same time, it is noteworthy that Gua assimilated many features of the human environment, and with this added stimulation might easily have become much superior to others of her species.

(B) COMPARISONS WITH OLDER CHILDREN. Several tests have shown that the maximum mental development of the higher apes—chimpanzees, gorillas, orang-utans—is about equal to that of a child of three or three and a half years. [1, 13] That is, both can solve problems of similar nature and degree of complexity. One psychologist tested his own three-year-old daughter and reported that she had about the same difficulties in solving the problems set her as did chimpanzees. The problems were such as pulling in an object with a stick, piling one box on top of another in order to get a food reward suspended higher than one's reach, joining two sticks together when neither is long enough to reach the food by itself, and lifting a ring from a nail to release a string in order to let the food drop. The same general emotional behavior was displayed: confusion, anger, loss of interest, and renewed attacks.

4. Social Behavior

There is often debate as to whether species below man have any "social feeling." A clever experiment was devised by Wolffe in which two monkeys or two children were put in cages side by side, so arranged that if *A* pulled a cord *B* got the food, and vice versa. The apparatus is diagrammed in Fig. 7. A grape was used as reward for the monkeys, and an animal cracker motivated the children. While the monkeys learned to manipulate the apparatus easily enough, it appeared that in this situation there was absence of definite cooperation, since they would pull in the cord as readily when the other cage was empty as when their partner was present. But with the children between three and five and a half years of age, language permitted social participation. We find reported such remarks as: "I'll pull yours in if you'll pull mine." "Pull it—I'll give you the cookie if you do." "If I pull that

cookie to you, will you give it to me?" "I'll even let you eat the legs." Wolfe sums up this comparative study as follows:

Formal language was the important type of behavior in securing and controlling the partner's cooperation. The monkeys could not talk and showed no signs of true cooperation. The youngest children could not talk well and consequently showed only slight indications of true cooperation. The older children talked fluently and secured ready cooperation. Formal language seemed to be a necessary basis for the development of cooperation in this experimental situation.⁸

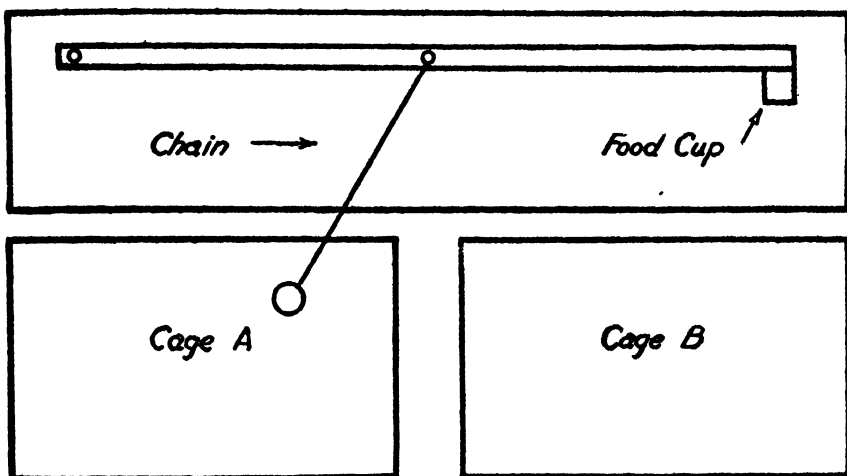

FIG. 7.—Diagram of Apparatus Used to Test Social Cooperation in Monkeys and Children.

The child or the monkey in Cage A pulls the chain attached to the pivoted lever, but the individual in Cage B gets the food. Thus social behavior is tested.

It has also been demonstrated that chimpanzees can learn to cooperate with each other in solving a problem. [2] A box was weighted too heavily for a single animal to pull in, but it could be pulled in by two chimpanzees if they pulled simultaneously on separate ropes. Such cooperation was not achieved immediately; there were several intermediate stages. It was easy enough for one anthropoid to pull in a weight commensurate with his strength. But two would not at first work together; one pulled while the other watched or played about the cage. Actual instruction aided greatly. The experimenter would gesture, or even call "Pull." In the next stage the animals became independent of the experimenter; one would watch the other pull and then

⁸Wolfe, D., Cooperation in monkeys and children. *J. Genet. Psychol.*, 1939, 55, 137-176.

time his own pull to synchronize with that of the partner. Finally the animal would solicit help from his partner with gestures when he realized that coordinated efforts were necessary to move the heavy box. This necessity finally led to rhythmical pulling.

Chimpanzees appear to be one step higher in "altruism," if the following behavior may be so termed, than the monkeys described by Wolffe. Two chimpanzees were given tokens which stood for food, but conditions were so arranged that the chimpanzee receiving the token could not exchange it himself for food. [18] This would reduce the incentive to keep the token, but would in no way force the animal to benefit his partner. The tokens would be passed from one cage to another, sometimes spontaneously, sometimes in response to begging. The experimenters described begging thus: "Typically the hand was turned palm up and the wrist, fingers, or both, flexed rapidly in a beckoning gesture. Frequently the animal whimpered or whined, softly at first and then more loudly until a high-pitched scream was reached. Stomping of the feet, rapid flexion and extension of the legs at the knee, and violent shaking of the grille often occurred." In Fig. 8 we show pictures of chimpanzees begging for and handing over tokens.

5. Human Beings in an Animal Environment

Suppose the situation set up by the Kelloggs were reversed, and a human being were brought up with animals. What would the results be? Legend gives us the tale of Romulus and Remus, raised from infancy by a she-wolf, who not only survived but became leaders in the founding of Rome. Fiction has also contributed the Tarzan stories. Tarzan grew up in the jungle, became a leader of the apes and even taught himself to read and write by puzzling out books he found. Later he adapted himself to civilization with the greatest of ease.

These examples, of course, are purely fictional. It is ordinarily impossible from a social point of view to perform experiments similar to the Kelloggs'. There have been several instances of human beings found living in uncivilized states, but no scientifically regulated experiments. The best known of these instances concerned a French boy who was found about the year 1800 wandering in the woods and living in most ways like an animal. Another instance was of two girls in India found living with wolves, and reported by a native minister in letters to American psychologists.

When the "Wild Boy of Aveyron" was captured he was in an extremely depraved state. He was about twelve years old and, according to stories of near-by villagers, had been in the wilds for about five years. It was hoped that a few months of training would restore him

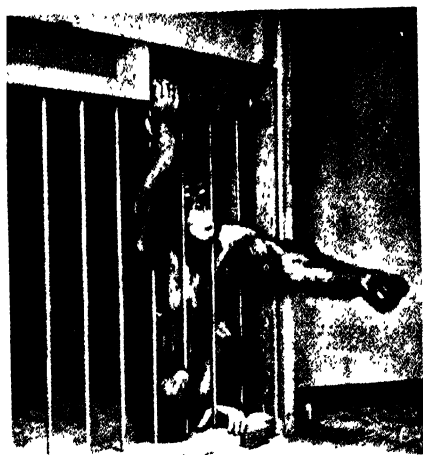

FIG. 8.—Here we see tests for possible cooperative behavior in chimpanzees. Begging is evident, giving not quite so often, but seen at times.
(Courtesy of Drs. Nissen and Crawford.)

to society, a hope that was far from realized. Because he was fortunate enough to fall into the sympathetic hands of Dr. Itard, [10] who taught him with infinite patience and understanding, he probably developed to the limits of his capacity.

At the time of capture the boy's eyes did not fixate on anything meaningfully, his hands could grasp but not explore, he paid little attention to most sounds, his voice was rarely used and then only to make guttural sounds, he did not seem to mind the foulest smells, and his reasoning and memory seemed non-existent. He did not walk in usual fashion, but trotted so fast that men could not keep up with him. He could apparently pass time indefinitely without boredom or dissatisfaction, just sitting and rocking gently like an animal. He slipped back and forth between slumber and wakefulness with ease. He sat for hours in snow or rain, he replaced burning embers on a fire and picked potatoes from a boiling kettle, and did not sneeze even when snuff was inserted into his nostrils. It was not long, however, before he recognized the value of clothing, especially on cold days. His sense of taste also became more refined.

Teaching the boy language was extremely difficult. The hardest step, and one which he never completely bridged, was in understanding the association between an object and a sound. He was given the name "Victor," and he responded to it readily. He used a few words or phrases: "eau" (water), "lait" (milk, imperfectly pronounced), and "mon Dieu" (an expression of disgust frequently used by the cook). He associated large printed words with objects, and fetched them. For example, if a card were held up bearing the word "knife," "pen," or "key," he would trot off and get the proper object. He even learned to get as many as four objects, all in one commission, although he sometimes forgot and had to come back to refresh his memory. He also learned to keep his personal property on a shelf, with the place for each possession indicated by its name printed on the wood, and was meticulous about that. It is likely, however, that this degree of knowledge and performance could have been achieved by a monkey, and much of it by a dog. Remember that the Kelloggs' ape learned ninety-five words and phrases.

Victor occasionally communicated a wish by gestures or acts. He liked to be pushed in a wheelbarrow, and would lead a person to it and then climb in. If the person failed to take the hint, he would grasp the handles, push the barrow a bit, and then return to his perch. Monkeys have been known to do the same thing.

His verbal associations were entirely specific, rather than general. For example, he recognized his own knife as a knife, and not any other.

From a whole library he picked as a book just one, one which was exactly like that in his own room.

His emotional development was meager. Whatever affection he exhibited came more from self-interest than from gratitude. Once he escaped to the forest and did not return until hungry. Laughter seemed to be imitative rather than a genuinely experienced feeling of amusement.

Of similar nature is the account of the Wolf Children of India, of whom reports are incomplete. [12, 20] These children, girls of about eight and two, were found living in a cave with wolves. They ran about on all fours, apparently in imitation of their associates. Itard's boy had walked upright, possibly because, living in isolation, he had developed the mode of locomotion best fitted to his skeleton. The younger of the two girls soon died, but the older survived several years. She learned about a hundred words, listened keenly to other people, but rarely spoke. She finally learned to eat like a human being. For a long time she lowered her face to eat or drink and did not use her hands.

To summarize, in neither of these cases did the individuals approach normality, and it appears practically certain that they never would have done so. Whether they were really feeble-minded, or had been permanently retarded because of protracted lack of intellectual stimulation is not certain. Probably both were contributing factors. In the case of Itard's boy there was the most conscientious and painstaking tutelage, yet he profited little from it. Some slight suspicion exists that he may have been the "village idiot"; if this suspicion is unfounded, we see demonstrated in a spectacular manner the importance of early environment and learning.

6. Primates: Symbolic Abilities

Do apes and monkeys think? Perhaps a better question would be: Do they employ symbols? Two of the most common human symbols are words and money. We say "horse" instead of leading a horse into the house when we wish to talk about one. We use metal and paper coinage instead of exchanging actual goods each time an economic transaction takes place. Some form of symbolic activity undoubtedly exists in primates even though it is short of actual language as human beings know it.

It is often said that the chief difference between man and animals is the possession of language. But words are not exclusively the property of man, since many animals associate words with objects and actions. We remember that the Kelloggs' chimpanzee was capable of responding

appropriately to ninety-five words and phrases. One police dog formed associations for more than a hundred words. Several species of animals give more or less purposeful cries which serve to communicate emotional states, such as a dog's snarl (anger) or bark (alarm). Symbolic activity certainly exists in monkeys and possibly to a slight extent in subprimate species.

(A) STRIVING FOR SECONDARY REWARDS. Wolfe [22] tried to see if a chimpanzee would learn to work for secondary rewards. Human beings will; we work not for food or clothing, but for money, a symbol to be exchanged later for things desired. Lower animals cannot be motivated indirectly; they need a definite and immediate food reward.

In Wolfe's experiment poker chips of various sizes and colors were used as rewards, each size or color representing a certain food, water, or activity reward. A "chimpomat" was set up; the ape would put the chip into a slot and the appropriate reward would come out, as from an automatic vending machine.

The chimpanzees learned with little difficulty to differentiate between the poker chips and brass disks. Then they were assigned to work tasks. They had to lift twelve- or eighteen-pound weights to earn their tokens. Three of the four apes worked as hard for tokens as for immediate food rewards. Some of the chimpanzees actually hoarded their "money." They worked until they had accumulated a few chips, which they used later, as they became hungry or thirsty. As long as they had a good supply of chips on hand, they would not work. They learned to choose the more appropriate reward: if they had been without water for some time, they chose the token which stood for a drink; if hungry, they chose the food token.

(B) STRING TESTS. String tests have been used extensively to study another form of symbolic ability in monkeys. [7] Monkeys and anthropoid apes without hesitation pull in objects by means of a string, as in situations A, B, and C, even when the problem is complicated by other strings. But D is beyond their abilities, since they consistently pull on the string which most nearly is a straight line toward the food. A rope loosely thrown over the handle of a basket presents a never-solved source of difficulty, as monkeys interpret touching to mean continuity. Likewise, they are unable to unwrap a rope from around an object, as the limb of a tree in E. Another difficulty is encountered in pulling the desired object over the limb of a tree, since tugging on the rope makes the object recede. To an animal of lower intelligence this is serious; it seems to be losing the object instead of bringing it closer. On the other hand, a more highly developed organism sees that this is the only way to get it. This "detour" type of situation ties up closely

with the observation in the Kelloggs' experiment that the child became adapted more readily to circumventing a closed door than could the chimpanzee.

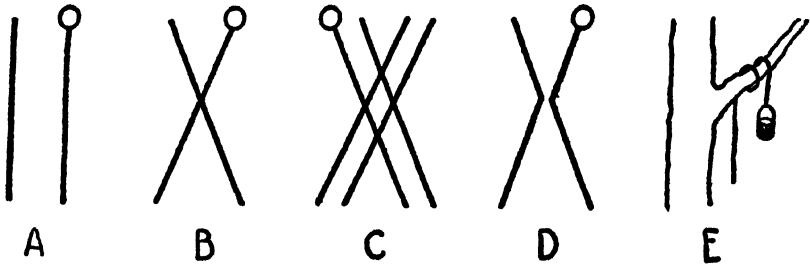

FIG. 9.—Problem Situations Used to Test Primates.

The monkey easily solves problems A, B, and C. Even the crossing in B and the four strings in C do not distract him from the food goal. But D and E prove difficult. In D the monkey looks along the line, does not notice the reversal. Problem E, where the basket hangs over the limb by loops, requires more complex intelligence.

(C) *DELAYED REACTION.* [8] If a bit of food is placed on a table covered with an inverted cup and an identical cup is simultaneously placed elsewhere on the table, the monkey or ape easily remembers which cup contains the food. After a certain delay, if the table is pushed within his reach, he will lift the correct cup and ignore the empty one. Most monkeys achieve delays as long as two minutes, and some can wait five minutes before memory is lost. [5] They can also remember the correct cup of each of two pairs presented simultaneously on a table. [6] One psychologist had the embarrassing experience of putting pairs of inverted flower pots in a circle around a room, and then seeing the chimpanzee get his food from under the correct one of each of sixteen pairs, although the experimenter himself had forgotten the sequence. [21]

Of importance is the fact that a primate can wander about its cage and still make the correct solution after a two-minute delay. In one case during the two-minute pause the animal was called to the rear of the cage, successfully negotiated a second test requiring a delay of half a minute, and then returned to the front to demonstrate memory of the first cup. In comparison, rats usually fail to solve problems if their bodily orientation is disturbed. Although we cannot say that solution of the problem requires ideas of rightness and leftness in language form, the effect is the same. The situation is similar to that of a golfer who locates a ball in the rough by noting that it went out near the fifth tree. With this cue he need not walk directly to the place but may look for the ball at his leisure.

(D) GENERALIZATION. Generalization has been tested by a maze with turns in a regularly alternating sequence: right, right, left, left, right, right, left, left. Human beings soon see the general principle and can continue correctly through an indefinite number of turns. Monkeys were able to handle a maze of sixteen turns. The rat, however, appeared to learn each turn as an isolated unit in completely rote fashion, and was unable to go beyond the original eight turns. [3]

Spence [23] tested the symbolic abilities of chimpanzees by using various multiple choice situations. The correct box was placed as follows: (1) Middle box of five boxes; (2) second box from the left end of six boxes; (3) right-end box of seven boxes; (4) left-end box of seven boxes. The chimpanzees were very successful. The first problem turned out to be hardest of all. It is possible that this is the one demanding the highest degree of symbolization, as the others possibly were more open to formation of routine position habits. Even though *the boxes were shifted about to prevent formation of highly automatic habits, it appeared that the anthropoids were generalizing; that is, they eventually solved the problem regardless of detailed location of the boxes.*

(E) COLOR VISION. Recently it has been established that monkeys possess approximately the same color vision as do human beings. [4] They are able to differentiate not only among the primary colors—red, green, blue, and yellow—but they also differentiate minutely between shades of the same color. The line is rather sharply drawn at the primate level. It is possible that fishes and bees have some rudimentary color vision. But rats, dogs, cats, and many other animals discriminate only in terms of intensity differences.

7. Mammals (Subprimate)

The author once conducted an experiment comparing the learning performances of college students and white rats. [9] The two mazes shown in the accompanying picture were used. They are identical in pattern, except that they are mirror images of each other, as may be seen if the two patterns are traced. Each starts off with a single turn in one direction, then there are three in a row the other way, two back the first way, and so on. The students learned in an average of seventeen trials, while the rats required twenty-four attempts. The ranges were from 5 to 31 for the first group, and 11 to 47 for the rats. In a similar experiment thirty days later human beings far surpassed rats in a memory test. [14]

Although the differences were comparatively small and the ranges overlapped, it is not to be construed that some of the rats were faster

with the observation in the Kelloggs' experiment that the child became adapted more readily to circumventing a closed door than could the chimpanzee.

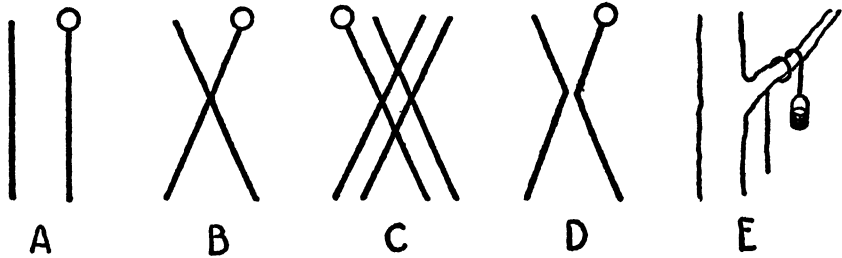

FIG. 9.—Problem Situations Used to Test Primates.

The monkey easily solves problems A, B, and C. Even the crossing in B and the four strings in C do not distract him from the food goal. But D and E prove difficult. In D the monkey looks along the line, does not notice the reversal. Problem E, where the basket hangs over the limb by loops, requires more complex intelligence.

(C) DELAYED REACTION. [8] If a bit of food is placed on a table covered with an inverted cup and an identical cup is simultaneously placed elsewhere on the table, the monkey or ape easily remembers which cup contains the food. After a certain delay, if the table is pushed within his reach, he will lift the correct cup and ignore the empty one. Most monkeys achieve delays as long as two minutes, and some can wait five minutes before memory is lost. [5] They can also remember the correct cup of each of two pairs presented simultaneously on a table. [6] One psychologist had the embarrassing experience of putting pairs of inverted flower pots in a circle around a room, and then seeing the chimpanzee get his food from under the correct one of each of sixteen pairs, although the experimenter himself had forgotten the sequence. [21]

Of importance is the fact that a primate can wander about its cage and still make the correct solution after a two-minute delay. In one case during the two-minute pause the animal was called to the rear of the cage, successfully negotiated a second test requiring a delay of half a minute, and then returned to the front to demonstrate memory of the first cup. In comparison, rats usually fail to solve problems if their bodily orientation is disturbed. Although we cannot say that solution of the problem requires ideas of rightness and leftness in language form, the effect is the same. The situation is similar to that of a golfer who locates a ball in the rough by noting that it went out near the fifth tree. With this cue he need not walk directly to the place but may look for the ball at his leisure.

(D) **GENERALIZATION.** Generalization has been tested by a maze with turns in a regularly alternating sequence: right, right, left, left, right, right, left, left. Human beings soon see the general principle and can continue correctly through an indefinite number of turns. Monkeys were able to handle a maze of sixteen turns. The rat, however, appeared to learn each turn as an isolated unit in completely rote fashion, and was unable to go beyond the original eight turns. [3]

Spence [23] tested the symbolic abilities of chimpanzees by using various multiple choice situations. The correct box was placed as follows: (1) Middle box of five boxes; (2) second box from the left end of six boxes; (3) right-end box of seven boxes; (4) left-end box of seven boxes. The chimpanzees were very successful. The first problem turned out to be hardest of all. It is possible that this is the one demanding the highest degree of symbolization, as the others possibly were more open to formation of routine position habits. Even though the boxes were shifted about to prevent formation of highly automatic habits, it appeared that the anthropoids were generalizing; that is, they eventually solved the problem regardless of detailed location of the boxes.

(E) **COLOR VISION.** Recently it has been established that monkeys possess approximately the same color vision as do human beings. [4] They are able to differentiate not only among the primary colors—red, green, blue, and yellow—but they also differentiate minutely between shades of the same color. The line is rather sharply drawn at the primate level. It is possible that fishes and bees have some rudimentary color vision. But rats, dogs, cats, and many other animals discriminate only in terms of intensity differences.

7. Mammals (Subprimate)

The author once conducted an experiment comparing the learning performances of college students and white rats. [9] The two mazes shown in the accompanying picture were used. They are identical in pattern, except that they are mirror images of each other, as may be seen if the two patterns are traced. Each starts off with a single turn in one direction, then there are three in a row the other way, two back the first way, and so on. The students learned in an average of seventeen trials, while the rats required twenty-four attempts. The ranges were from 5 to 31 for the first group, and 11 to 47 for the rats. In a similar experiment thirty days later human beings far surpassed rats in a memory test. [14]

Although the differences were comparatively small and the ranges overlapped, it is not to be construed that some of the rats were faster

learners than some of the college students. Rather it shows that the rats had a special fitness for this fairly simple test. If a greater degree of symbolization had been required, their record would not have been so good.

Of more interest to us is the fact that rats and men learned in different ways, as evidenced by the types of errors each made. The college students made errors in a sequence, while sequences are an aid to rats. Notice that choices 2, 3, and 4 turn in the same direction. With human beings few errors are made on the second, more on the third, and a great many on the fourth turn. But with rats fewer and fewer are made on these same three turns. The order of learning also is different. Human beings tend to learn the first and last portions earliest, while the rats learned the last (nearest the food), then the middle, and finally the first few turns. Thus we have evidence not so much of different ability levels as of different ways of learning.

8. Lower Organisms

In human beings, learning and insight are of vast importance, but the lower animals are governed more completely by their innate dispositions, instincts, and simple habits. The lower down the scale we go the less relative importance learning has. Birds display their lack of adaptability by flying at the same plate-glass window dozens of times in succession, apparently without realizing that transparency does not mean openness. In fish and amphibia learning is only relative and meager. Time of learning is reduced and fewer mistakes are made, but they never react quickly nor do they free themselves from the possibility of error.

Metfessel conducted an interesting experiment to ascertain the relative importance of heredity and environment in the song of canary birds. [15, 16] Bird lovers identify various species by their characteristic songs. The experiment attempted to answer these questions: Are songs inherent in the species or are they learned through imitation of others of their kind? Can the song be changed? If so, to what degree? Are there limitations which militate against change? Metfessel collected a number of canaries, trained by their owners to sing certain songs, and carefully measured their exact song by phonophotographic methods. In this way he obtained a more accurate record of what they actually sang than can be received by listening or even by taking down the songs in musical notation.

He found that canaries cannot learn to sing every kind of tune. Among those they can be taught are: "Pop Goes the Weasel," "Hail, Hail, the Gang's All Here," "Yankee Doodle," and "Holy Night, Silent

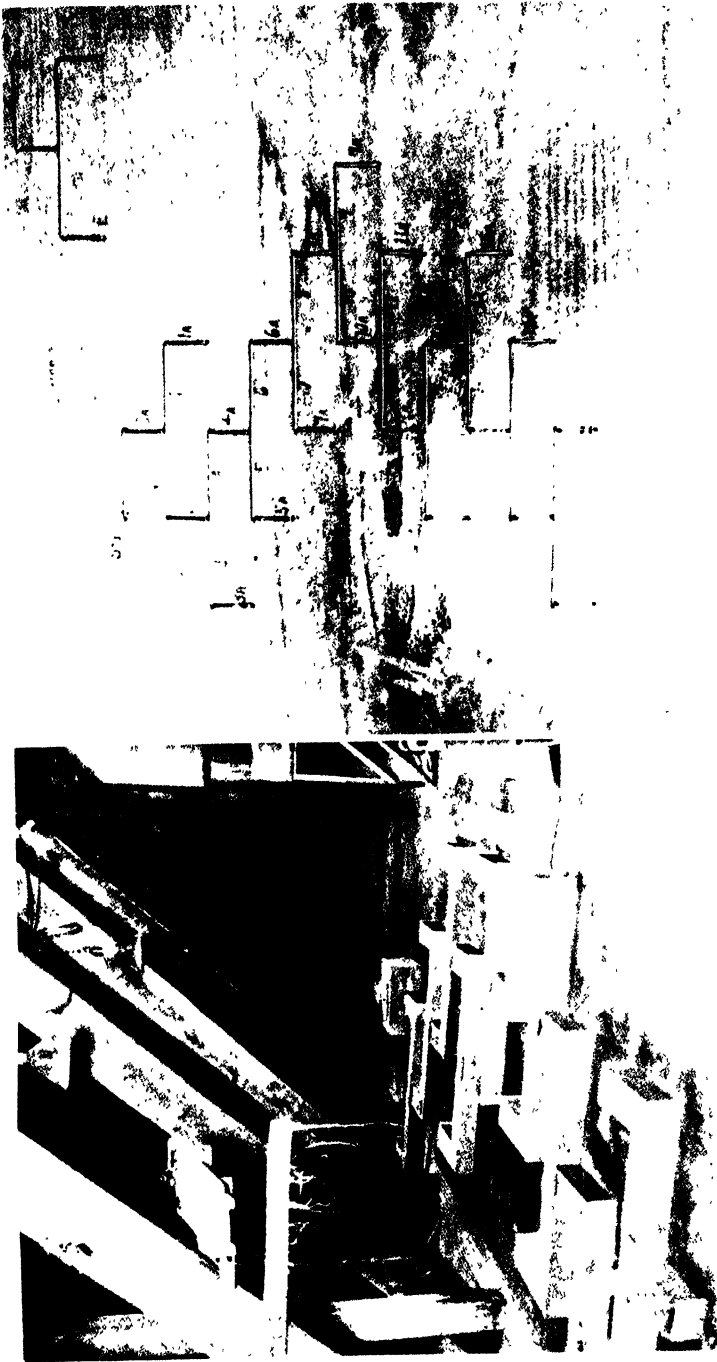

FIG. 10.—Rat and human maze patterns.

Photographs of the mazes used to test learning abilities of college students and white rats. They are mirror mazes of each other, but otherwise are identical in pattern. Naturally the rats run through the maze, while human beings are blindfolded and trace over the raised wire paths with their forefinger



FIG. 11.—Facial expressions of the koala bear.
A tourist book calls these "Disdain" and "Astonishment." Is there any sound basis for such designation?

Night." Hundreds of trials were necessary and the result was not always satisfactory, although the tunes were easily recognizable. The melody had to be within a certain range and of a certain general type. "Holy Night" was not sung in the customary stately fashion, but was trilled as rapidly as "Yankee Doodle." The canary naturally sings rapidly, and if he is taught another type of melody he distorts it to his characteristic mold.

The results of this experiment tend to effect a compromise between the extreme hereditarian and environmentalistic views. The canaries developed new songs, but the tone quality and manner of singing were always peculiar to canaries. The playing of a violin solo on a trombone is analogous. The melody might be perfectly recognizable, but anyone would know he was listening to a brass instrument, not a violin. A canary reared with other birds acquires their melodies, but naturally develops the familiar rolls and tours. Reared in isolation the same thing occurs—rolls and tours, but original melodies. The characteristic type of note is undoubtedly caused by the physiological structure of the bird's throat, and possibly in part by functional characteristics which may or may not depend upon nervous structure.

9. Warnings, Fallacies, and Errors

(A) **ERRONEOUS IDEAS.** After the principle of evolution had secured a degree of acceptance, many stories about the wonderful behavior of various animals were uncritically accepted. We have seen that, although apes may be the equals of young children in some ways, vast differences appear in the highest mental processes, involving generalization, reasoning, problem solving, and language usage. When adult members of each species are compared, the differences are especially pronounced. Evolution means continuity of development, but it does not in any sense postulate equality of abilities.

Structure-function parallels are commonly drawn, and frequently lead the unwary into errors. If the external behavior, or even the facial expression, of an animal happens to resemble that of a human being, the assumption is often made that it is experiencing a similar intellectual or emotional process. Even though we sometimes see pictures of dogs or cats laughing, looking bored, or exhibiting some other emotion, it is extremely doubtful that such labeling has a grain of truth. To illustrate, we give in Fig. 11 two pictures of the Australian koala bear, a rather primitive marsupial (pouched) form.

(B) **LLOYD MORGAN'S CANON.** In 1893 Lloyd Morgan, a famous English scientist, issued his widely quoted canon, sometimes termed the "Law of Parsimony." This principle states that behavior should be ex-

plained in the simplest possible way. [17] Instead of jumping to the conclusion that a certain act is evidence of intelligence, it is more scientific to select an elementary alternative and term it instinct, habit, or native drive. Thus, if you see a trained seal or dog (or even a friend's child) do some apparently marvelous stunt, ask, before you give him credit for superior ability, how long it took to teach him that act, how many times he has repeated it, and whether it fits in with some special ability. By special ability we mean such aptitudes as that of the spotted Dalmatian dog that runs directly under the rear axle of a coach, seals that play horns in proper sequence and juggle balls, and "Seeing Eye" police dogs. These species are especially fitted for such tasks, and would quite likely fail to acquire other habits of no greater complexity.

(C) FALLACIES. There are two quite common sources of error in interpreting animal behavior. First, the animal may pick up extraneous cues. For example, a famous horse in Germany was reputed to perform mathematical calculations. When a group of scientists tested him, they discovered that he failed to do his problem if the owner was out of the room. Hence they concluded that the horse received cues from the owner. When the horse pawed eight times after he had been asked for the square root of sixty-four, the scientists noticed that the owner moved his head slightly in time with the horse's hoof. After the proper number of strokes the owner's head stopped and the horse also stopped. Perhaps the owner did not realize that he had been providing the horse with cues. In another instance, a police dog walked to the door, window, and radiator in response to spoken commands. To the trained observer it was apparent that the most obvious cues were being given, both by the owner who leaned in the proper direction and by the witnesses who opened lanes to the designated objects.

Some animals are taught to perform acts in a certain order. A dog may go to the door, paw out the number of days in the week, and shake hands. But if you first ask him how many days there are in a week, he will go to the door; tell him to go to the door and he will paw seven times, and so on.

In evaluating claims of special ability, the animal should be tested without the owner present, with the examiner behind a screen, with commands given in random order, and with all possible sensory cues controlled.

(D) EMERGENT EVOLUTION. We have previously mentioned that evolution does not postulate that the same abilities are present in all species from lowest to highest. When higher species appeared—for instance, when the primate order emerged from the mammalian—entirely new abilities likewise emerged. Reasoning ability is present in

man, the higher apes, and the monkeys, but very little if any in the infraprimate mammals. Below the vertebrate level is another line of demarcation. Learning is limited in scope. In fishes, for example, it is slow, limited, and uncertain. Rats, on the other hand, are capable of forming complex and precise habits. A physical parallel to this principle is seen when two gases, oxygen and hydrogen, are combined to form water, which has properties of liquidity, greater density, and wetness not possessed by either gas.

SUMMARY

At the beginning of this chapter we enunciated the Genetic Viewpoint, that the whole of life is growth, development, change, and learning. This will constitute our approach to all the topics of psychology. Hence we shall trace the development of each aspect of human behavior from birth, through childhood and adulthood, to old age.

Mental evolution, illustrated by a comparison of human beings and animals, forms the factual basis of this chapter. The Kelloggs' remarkable experiment showed that the sensory, motor, and intellectual behavior of a young chimpanzee and a boy of the same age were essentially similar. The chief psychological difference was that the chimpanzee could not acquire motor speech, although she did learn to understand many spoken words and phrases. After the child had reached the age of two or three, he would begin to draw well ahead of the chimpanzee, since the latter's maximum mental development could not exceed that of a child of three or three and a half years.

We saw that with the aid of spoken language, preschool children demonstrated ability to cooperate with each other. Chimpanzees showed similar social willingness, but monkeys displayed little cooperation.

In discussing several experimental studies of animals on different levels, we saw that qualitatively different and higher abilities emerged as higher levels of species were studied. The lowest animals behaved largely in accordance with instinct and native traits; their learning was scanty and of poor quality. Mammals learned many habits, but tended to be routine in their use. Monkeys and anthropoid apes possessed a good degree of symbolic ability, as demonstrated by their willingness to work for secondary rewards, to solve problems of novel nature, such as string tests and tests in delayed reaction. The chief differences between primates and man lay in man's ability to solve more difficult problems and in his use of purposeful language for communication.

Finally, we gave a number of warnings and cautions concerning the interpretation of quality of behavior in animals.

REFERENCES

1. Brainard, P. P. The mentality of a child compared with that of apes. *J. genet. Psychol.*, 1930, **37**, 268-293.
2. Crawford, M. P. The cooperative solving of problems by young chimpanzees. *Comp. Psychol. Monogr.*, 1937, **14**, No. 68.
3. Gellermann, L. W. The double alternation problem. *J. genet. Psychol.*, 1931, **39**, 50-72, 197-226, 359-392.
4. Grether, W. Color vision and color blindness in monkeys. *Comp. Psychol. Monogr.*, 1939, **15**, No. 4.
5. Harlow, H. F., Uehling H., & Maslow, A. H. Comparative behavior of primates. I. Delayed reaction tests on primates from the lemur to the orang-outan. *J. comp. Psychol.*, 1932, **13**, 313-343.
6. Harlow, H. F. Comparative behavior of primates. III. Complicated delayed reaction tests on primates. *J. comp. Psychol.*, 1932, **14**, 241-252.
7. Harlow, H. F., & Settlage, P. H. Comparative behavior of primates. VII. Capacity of monkeys to solve patterned string tests. *J. comp. Psychol.*, 1934, **18**, 423-435.
8. Hunter, W. S. Delayed reaction in animals and children. *Behav. Monogr.*, 1913, **2**.
9. Husband, R. W. A comparison of human adults and white rats in maze learning. *J. comp. Psychol.*, 1929, **9**, 361-377.
10. Itard, J. M. C. The wild boy of Aveyron. New York: D. Appleton-Century Co., Inc., 1932.
11. Kellogg, W. N. & L. A. The ape and the child. New York: McGraw-Hill Book Co., Inc., 1933.
12. Kellogg, W. N. More about the "wolf children" of India. *Amer. J. Psychol.*, 1931, **43**, 508-509.
13. Köhler, W. The mentality of apes. New York: Harcourt-Brace & Co., Inc., 1925.
14. Lathan, C., & Fields, P. E. A report on the test-retest performance of 38 college students and 27 white rats on the identical 25 choice elevated maze. *J. genet. Psychol.*, 1936, **49**, 283-296.
15. Metfessel, M. Objective studies of roller canary song. *Psychol. Bull.*, 1935, **32**, 716-717.
16. Metfessel, M. Effect of vibrato stimulation on natural song of roller canaries. *Psychol. Bull.*, 1936, **33**, 806-807. (Also presidential address of the Western Psychological Association, 1937.)
17. Morgan, C. L. An introduction to comparative psychology. (2nd ed.) New York: Charles Scribner's Sons, 1903, p. 53.
18. Nissen, H. W., & Crawford, M. P. A preliminary study of food-sharing behavior in young chimpanzees. *J. comp. Psychol.*, 1936, **22**, 383-419.
19. Spence, K. W. The solution of multiple choice problems by chimpanzees. *Comp. Psychol. Monogr.*, 1939, **15**, No. 3.

20. Squires, P. C. "Wolf children" of India. *Amer. J. Psychol.*, 1927, **38**, 313-315.
21. Tinklepaugh, O. L. The multiple delayed reaction with chimpanzees and monkeys. *J. comp. Psychol.*, 1932, **13**, 207-243.
22. Wolfe, J. B. Effectiveness of token rewards for chimpanzees. *Comp. Psychol. Monogr.*, 1936, **12**, No. 60.
23. Wolfe, D. Cooperation in monkeys and children. Also *J. genet. Psychol.*, 1939, **55**, 137-176.

III

CHILD DEVELOPMENT

I. BIRTH EQUIPMENT

1. What We Inherit

(A) MEANING OF THE TERM "HEREDITARY." Only those traits which have been handed down from our ancestors by way of the germ plasim can properly be called hereditary. It is generally considered that anccstral contributions are one-half from parents, one-quarter from grandparents, one-eighth from great-grandparents, and so on. Male and female lines contribute equally. *Heredity is complete at the moment of conception.* Any changes after that, even during gestation, arc as truly environmental as a summer tan or a French accent. Examples of these are disorders from malnutrition or chronic diseases of the mother, malfunctions of glandular secretions prior to birth resulting in dwarfism and other disorders, birth injuries, or cleft palate.

(B) EXTENT OF INHERITANCE. Actually, we can find little of a truly psychological character that is inherited. Many of the so-called inherited traits are either peculiar to that individual alone or have been acquired through social imitation of an ancestor. Among the inherited characteristics of human beings are such things as physical structure, eye color, skin pigmentation, and curliness of hair. Physical characteristics do exert an indirect influence upon behavior. Because we have a human skeleton we walk upright. A dog must walk on four legs because of the nature of his bone structure. Still farther down the scale is the snake, whose structure necessitates a wiggling and burrowing kind of movement. If a person is born with a crippled right hand (innate but not hereditary), he will almost certainly become left-handed. If a person is deficient in certain glandular secretions, he will

lack the physical energy necessary for leadership. People with stubby fingers usually fail to become better than mediocre pianists. Structure limits function. Recently the author met a friend's son and noticed that his smile was just like his father's. Could the tendency to smile in a certain manner be inherited? No; the shapes of their faces were alike, and the smiles inevitably were similar. The similarity was, no doubt, accentuated by imitation.

(C) MECHANISMS OF HEREDITY. Since there is little direct inheritance of psychological traits, it would be inappropriate to devote much space to a discussion of the biological and mathematical angles. We know that the chromosomes of the male and the female are united in a complex and unpredictable way. This explains differences among children of the same two parents. Because certain traits are dominant, we know that heredity is not pure chance. Brown eyes appear in three-fourths of the offspring of parents one of whom has brown eyes and the other blue eyes. Normal intelligence appears to be dominant over either feeble-mindedness or brilliance.

However, psychological inheritance does not follow mathematical laws as do eye color and other well-defined biological characteristics. Intelligence certainly is not an inheritable trait; we are not convinced that it is at all dependent upon the chromosomes. There are not merely three classes of people: normal, subnormal, and superior; there are many intermediate grades. Some traits are innate but not hereditary. For example, left-handedness sometimes appears spontaneously in a child none of whose ancestors have been known to be other than right-handed.

(D) FAMILY RESEMBLANCES. (1) *Intelligence*, as we shall see, is roughly equal to that of the general level of one's family. Nevertheless, any individual may show a wide deviation from his family level. A boy from the slums may become eminent, and the son of a famous scientist may be feeble-minded. But neither case occurs very often. More frequently the deficient person springs from the slums and the superior child from superior parents.

(2) *Insanity* is not, as sometimes claimed, hereditary. The most we are warranted in saying is that it occurs, like left-handedness, more frequently in certain families than in the general population. The only strictly hereditary characteristic is a vague tendency toward an unstable nervous system which predisposes toward breakdown in an emotional crisis. That is, some people break down under the same conditions of stress from which others recover. But even instability may be acquired from associates and surroundings. Chances that a child reared in a family in which several members were unbalanced might become

abnormal are greater than if the same child had been brought up among more normal people.

(3) *Aesthetic achievement* runs prominently in certain families. Several members of the Bach, Strauss, and Wagner families have attained eminence in music. In every community certain families are known to be musically inclined. Both heredity and environment play their parts here. Heredity probably contributes better than average pitch discrimination, sense of harmony and rhythm, but not musical proficiency as such. Exposure from an early age to a musical environment, plus practice, adds skill to superior endowment.

(4) *Sensory deficiencies*, such as inability to perceive certain colors or to taste certain substances, follow definite ratios. Color deficiency, for instance, is a sex-linked trait; it appears only in males but is passed along by females, thus skipping a generation.

(5) *Habits of behaving*, such as personality traits, the type of jokes which amuse one, criminality, political affiliations, or manners of gesturing, are all obviously acquired. What in the germ plasm could possibly make father and son behave alike in such respects? This question may be asked whenever excessive claims are made for the influence of heredity upon psychological traits.

2. Nature of Birth Equipment

Since we are going to watch the child grow up to become an adult, learning and developing in all sorts of ways, let us see what equipment he begins with at birth. Such an inspection may be compared to the contractor's inventory of raw materials: lumber, bricks, cement, shingles, glass, and the like. The child's development is compounded of his native equipment, the raw materials of his existence. His speech is formed from the random vocalizations he makes soon after birth. In walking he uses the random movements his legs made when he lay on his back in the crib.

Before we catalogue native equipment we must emphasize that it is somewhat misleading to attempt hard and fast classification of behavior of the newborn infant. We quote the following passage to show how indefinite and vague is his behavior:

Although we cannot peer into the mental life of the newborn child, careful observation of his behavior leads us to believe that there would not be much to see. His movements are many, but they are aimless and undefined. He can breathe, sneeze, yawn, and perform many reflex acts, but even some simple reflexes are still undeveloped. His eyes move in different directions. He shows no clear-cut emotional patterns. He is relatively insensitive to pain. In response to being touched and handled or in response to lights and

sounds, he may cry and perform many movements, but few of these are coordinated or adapted to the stimulus that is applied. He lacks not only experience but also the machinery necessary to entertain impressions similar to those entertained by adults.

Changes in the child's behavior come rapidly, even during the first few hours of life. After a short time one can hardly recognize the same creature. If we could trace all of these early changes, we would have an insight into human nature that a study at no later period of life could give. Long before the age of five or six, when the usual child is first seen at school, he has already passed through the most important formative part of his career. [12]¹

In brief, in the newborn child almost any stimulus can elicit virtually any response. Someone bending over the crib, before the child is old enough to recognize any particular person, may start any sort of activity: babbling, laughing, or crying, approaching or withdrawing movements, various facial expressions, movements of limbs and trunk. Many of the actual movements are much the same as in adults, except that they are poorly coordinated and usually more violent than necessary. Accuracy of reaching is poor, because of both faulty coordination and poor judgment of distance. Movements are gross. Whereas the adult may move just one finger to rid himself of a fly, an infant thrashes around with his whole body.

3. Classification of Birth Equipment²

(A) **PHYSIOLOGICAL FUNCTIONS.** Obviously, if the infant is to survive at all, he must be a self-sustaining organism. At birth his circulation becomes separate from that of his mother, and breathing is established. His suckling reflex operates to take in food. Digestion and elimination operate automatically. Yet the child is completely helpless as far as taking care of himself is concerned. His food must be placed directly into his mouth. His elimination is uncontrolled, and he must remain in discomfort until his diapers are changed. For the first few months he sleeps more than he is awake. He might be compared to an engine, which consumes gasoline and oil and requires occasional adjustments and repairs.

(B) **RANDOM MOVEMENTS.** Random movements furnish dynamic raw materials which serve to build up locomotion, hand and foot coordination, skilled acts, and speech. The child can make nearly every

¹Jersild, A. T. *Child psychology*. New York: Prentice-Hall, Inc., 1935, p. 1.

²For present purposes we are summarizing briefly. The interested reader can find more details in any of the standard texts on child psychology listed at the end of the chapter.

sound and nearly every motion of which you and I are capable, but he cannot yet combine them into proper sequences. The infant cannot pronounce "metaphysical" nor can he dance a tango, but he can and does pronounce each syllable of the word "metaphysical" individually at one time or another, and slow-motion pictures have shown that he makes all the movements of the tango. Such activities, random as they may be, are valuable in developing muscular strength and control. It seems probable that these random movements are expressions of surplus energy and not, as older writers used to explain, for the prime purpose of preparing for specific kinds of future behavior, such as dancing the tango and reading poetry.

(C) REFLEXES. Because of their more simple and automatic nature, reflexes are more directly explained in terms of definite cause and effect than are most psychological processes. But in the infant even simple patterns are not yet well established. Some native reactions are weak or are elicited only by the application of a strong stimulus. Others are greatly exaggerated, showing lack of inhibition, which in turn suggests that the higher brain centers are not yet functioning perfectly.

Some of the reflexes present at birth are sneezing, yawning, hiccoughing, suckling, elimination, face and head movements, pupillary changes, turning eyes toward bright lights, arm and hand movements, and movements of trunk and legs. [5, 10, 31] Many of these have definite adaptive and survival value. Sucking is exceptionally well developed; the newborn infant not only coordinates his sucking and swallowing, but his endurance in this act is amazing.

(D) SENSORY CAPACITIES. The sensory capacities are relatively undeveloped at birth. [25] Eye movements are slow and uncoordinated. Distance vision is confined to a few feet during the first several months. The child can follow a slow-moving flashlight in an up-down or right-left direction, but he has difficulty if it is revolved in a circle. Some child psychologists say that audition is the most poorly developed sense at birth; nevertheless loud sounds frighten babies. Taste and smell seem relatively blunt, since the infant is not as distressed as the adult by unpleasant stimuli like salt water, quinine, or ammonia. Yet in some capacities he discriminates closely. Even a child a few days old may refuse cow's milk if he has been breast fed. The total impression probably consists in smell, temperature, and consistency, as well as pure taste. Temperature sensitivity seems good. The infant is very particular about such things as the warmth of his milk and his bath water. [11] Finally, touch sensitivity is good, but sensitivity to pain is not well developed. During the first week a boil may be lanced with no anesthetic and not cause serious discomfort. Pain in the adult is often

produced as much by anticipation as by actual sensation, as those people who fear the dentist's chair know well.

(E) EMOTIONS. The infant's emotions are vague and generalized.

The first emotional reactions of an infant are vague, undirected movements which seem to be somewhat proportional to the intensity of the exciting situation. Attempts to classify these reactions in terms of adult emotions are futile. These vague reactions soon become related to specific situations and consequently acquire meaning to the individual through such relationships. [19]^a

Psychologists disagree as to what emotions are present at birth or shortly thereafter. The list which seems to have gained the most widespread acceptance is Watson's. [31] He names three: fear, anger, and love or sensitive zone reaction. Fear is elicited by sudden stimuli, chiefly loud sounds and loss of support (dropping). Anger is produced by physical restraint. Sensitive zone reactions are brought about by stroking the lips, face, sex organs, or other sensitive regions. All adult emotions are said to be conditioned upon these few native ones. Certain situations are associated with sudden stimuli, and thus a new specific fear is acquired. For the mature adult social restraint has acquired the controlling effect of physical restraint in the repression of anger. We shall discover more about the acquisition of emotions in Chapter VII.

(F) PERSONALITY. Personality traits are almost entirely acquired, but it is barely possible that a few broad predispositions may be innate. Some children while still in the crib appear more sociable than others, exhibiting tendencies which are said to persist with the passage of the years.

II. EARLY DEVELOPMENT: MATURATION

1. Definition

The preceding section sets forth the list of equipment with which the child is born. In this and the next section we shall see how he develops during his early years.

In general, development occurs in two ways: (1) *Maturation* and (2) *learning*. Maturation is defined as the process of development or growth which originates from within the organism. This contrasts with learning, where the stimulation comes from some external source.

Maturation applies to both physiological and psychological growth. Physiological examples are the development in the fetus first of the whole limb, next the hand, and finally the fingers, the cutting of teeth a

^aMorgan, J. J. B. *Child psychology*, 3rd ed. New York: Farrar & Rinehart, Inc., 1934.

few months after birth, the onset of sexual maturity at about thirteen years of age. Psychological examples are development of locomotion, improvement of fine muscular coordinations, and growth of powers of reasoning.

Maturation might seem to belong with learning, since the individual does not have certain capacities at the time of birth and does have them later. But as we shall demonstrate in the next few paragraphs, this would be a mistaken assumption. Maturation is really a part of one's innate endowment. This in turn means that our birth equipment does not represent the sum total of our endowment. For twenty years after birth there appear traits that do not involve learning in any way.

We do not learn to walk. This is one of the best concrete examples of maturation. Actually, we develop skeletal strength, muscular strength, and nervous control to the point where walking becomes possible. This is proved by cases of children who because of some ailment are not allowed to walk until later than usual. Such children do not require the customary number of weeks to go through the stages of crawling, creeping on all fours, standing while holding to furniture, and so on. Rather, they pass through each in a day or two, and may even appear to skip some stages entirely. They become able to walk almost immediately upon being allowed to move about at will. If walking were an act of pure learning, such a child would be expected to require about the same length of time as does the healthy child.

Further evidence that this type of behavior is truly maturation and not learning comes from studies of premature babies. Those born prematurely are temporarily retarded in their motor development. For example, a baby should hold his head up one month after birth. In actuality, he is not just one month old—ten months have elapsed since he began his existence. So, if he is born after seven months of pregnancy, he will be three months old, by the usual reckoning, before the neck muscles have matured sufficiently to sustain the head upright. And there will be similar delays in the appearance of other motor traits. Naturally, such slight differences will mean little to the adult or even to the child beyond a year or two of age, but the effects of prematurity may temporarily create an erroneous impression of retardation. [8]

From the standpoint of maturation the exact time of birth is of little importance. Although forty weeks of gestation is average, birth with survival has been recorded all the way from twenty-four to forty-eight. The prematurely born infant has not yet attained all those functions which are present in the infant delivered at normal term. He must catch up, like a runner who starts behind the other contestants. To take a concrete example: the knee jerk appears during the seventh

month; hence, if the child is born after only six months of prenatal development, he will not have this function for another month. A child born at the usual period will have had this reflex for two months. In parallel fashion, the postmature child, while not common because of medical intervention, will be just as advanced as if he had spent the additional time in the external environment.

2. Maturation in Early Years

(A) DEVELOPMENT OF LOCOMOTION. The study of developing locomotive movements is fascinating, not only because it illustrates maturation, but also because it provides a practical understanding of child development. Shirley [26] conducted a thorough study of this subject on twenty-five infants, testing them every week during their first two years. The accompanying silhouettes are worthy of careful study. They show the regular sequence of motor development, from simple to complex. For instance, we see that the child can stand holding to furniture at nine months and can creep at ten months. The order of these stages is never reversed. One child may be advanced or retarded in comparison with others, but in each individual we find a standard sequence.

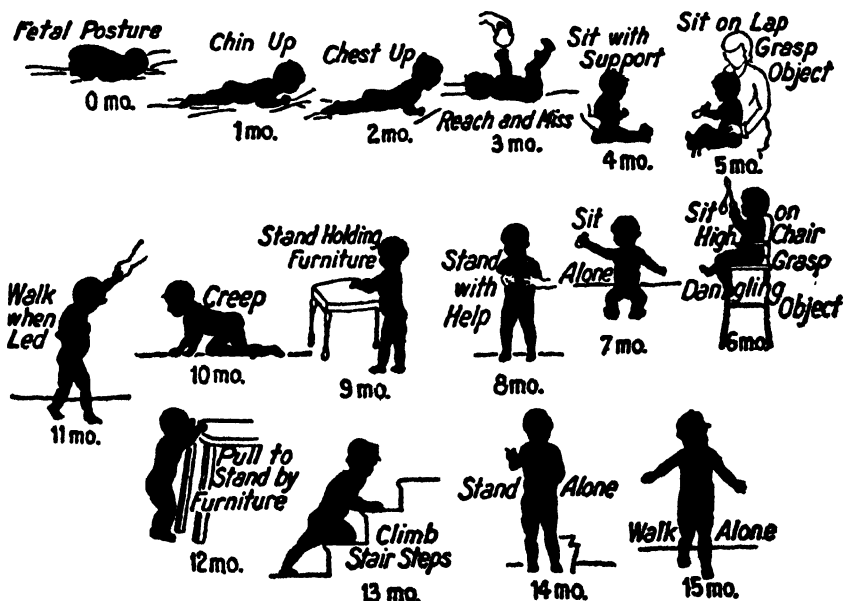

FIG. 12.—Maturational Sequence.

These silhouettes illustrate roughly what the average child will do at various ages. (From Shirley.)

To illustrate the differences in rate of development of various children, we quote in Table 2 additional data from the same investigation by Shirley. The median represents the age in weeks when half the children had attained each particular skill. The figures under Q_1 and Q_3 give the ages when 25 and 75 per cent have become able to perform the designated acts.

TABLE 2

THE MEDIANS AND QUARTILE RANGES FOR EACH STAGE OF MOTOR DEVELOPMENT [26]

DESCRIPTION OF STAGE	AGE IN WEEKS		
	Q_1	Median	Q_3
First-order skills:			
On stomach, chin up.....	2.0	3.0	7.0
On stomach, chest up.....	5.0	9.0	10.0
Held erect, stepping.....	11.0	13.0	15.0
On back, tense for lifting.....	14.0	15.0	18.0
Held erect, knees straight.....	13.0	15.0	19.0
Sit on lap, support at lower ribs and complete head control	15.0	18.5	19.5
Second-order skills:			
Sit alone momentarily.....	20.5	25.0	26.0
On stomach, knee push or swim.....	22.0	25.0	27.0
On back, rolling.....	25.0	29.0	32.0
Held erect, stand firmly with help.....	29.0	29.5	33.0
Sit alone 1 minute.....	27.0	31.0	34.0
Third-order skills:			
On stomach, some progress.....	32.5	37.0	41.0
On stomach, scoot backward.....	34.0	39.5	45.5
Fourth-order skills:			
Stand holding to furniture.....	41.0	42.0	45.0
Creep	41.0	44.5	45.0
Walk when led.....	37.5	45.0	45.5
Pull to stand by furniture.....	42.0	47.0	49.5
Fifth-order skills:			
Stand alone.....	56.0	62.0	66.0
Walk alone.....	59.0	64.0	67.0

The order and rate of appearance of the various locomotor abilities are so uniform that it is possible accurately to predict from the date of earlier and simpler functions just when the more complex ones will appear. For example, the third trait given in Table 2—stepping movements when held erect—occurs at about a fifth of the age when the child may be expected to walk. Therefore a child who is slightly advanced and gains this first ability at twelve weeks should walk at sixty weeks which, as we may see by consulting the bottom line of the table, represents a corresponding degree of advancement.

These locomotor accomplishments often appear quite suddenly.

Although no progress may have occurred for several weeks, the next stage may appear suddenly. And it may be an almost perfect performance, not just a crude attempt. The mother of one of Shirley's group of experimental babies says:

"I must tell you . . . Jimmy walked well the night after you last measured him. [The mother had become discouraged and thought he would never walk.] Just before dinner I ran to the corner grocery on an errand. When I came back there walked Jimmy to the door to meet me! And he walked the whole evening long. After dinner his daddy and I sat and watched him pace up and down and up and down this room. He must have made fifty trips if he made one . . ."⁴

This same principle is true of older children or adults when they first try to ride a bicycle. They may try dozens of times and fall off almost immediately, and then suddenly become able to keep their balance and ride along indefinitely.

(B) MANUAL MANIPULATION. Shirley also studied the development of finer motor coordination, testing such activities as reaching, grasping, and using toys and table implements. Table 3 lists many of the traits found in daily life. Just as with walking, there is a high degree of consistency in the rate of appearance of these various traits.

TABLE 3
AGES OF ATTAINING MANUAL MANIPULATION ABILITIES [26]

REACTION	AGE IN WEEKS	
	Range	Median
Reach and touch object.....	9-25	14.0
Reach and grasp object.....	5-23	15.0
Put object in mouth.....	9-20	15.0
Hold bottle for nursing.....	14-45	22.0
Hold spoon for eating.....	16-45	33.0
Pick up small objects.....	33-49	37.0
Wave bye-bye.....	26-50	38.0
Hold cup for drinking.....	26-46	38.0
Play pat-a-cake.....	25-50	39.5
Try to put on clothes.....	33-49	40.5
Pull plug out of bathtub.....	33-51	42.0

(C) INTELLECTUAL ABILITIES. The intellectual abilities are more subject to learning than are motor functions, but they also involve maturation. Prerequisites for certain school subjects furnish practical

⁴Shirley, M. The first two years. Minneapolis: Univ. Minn. Press, 1931.

examples of this. Psychology is customarily taught as a college sophomore subject. If it is given at an earlier level, it must be simplified and some of the more abstract concepts must be omitted entirely. Yet there is no course which leads up to psychology, so it is a question entirely of intellectual maturity, and not one of previous preparation. We find, for instance, that a child must be three years mentally before he knows he has a last name; he cannot count thirteen pennies until he is six years mentally; and he cannot define an abstract word such as "revenge" or "justice" until he is twelve. Other examples are seen in the latter half of Table 4.

(D) **NORMS OF DEVELOPMENT.** While looking over the chart and Tables 2 and 3, it may have occurred to you to check on the comparative rate of development of some child you know—perhaps a younger brother or sister, or the child of a near relative. Norms for this special purpose have been prepared by Gesell from extensive research on the development of infants in the Yale Clinic of Child Development. [7] Gesell has studied a great many children of various ages and classes of family and has obtained not only averages but also figures on retardation and acceleration.

Such standard figures are termed norms. A *norm* is a figure or series of figures serving as a standard of reference, such as 98.6 for body temperature, 75 as passing on an examination, or 73 as par for a certain golf course. Gesell expresses the summaries in terms of letter grades. The following table shows how the various letter grades are interpreted:

A+	means that fewer than 20%	} of infants can do the act at that age
A	“ “ fewer than 50%	
B+	“ “ 50 – 64%	
B	“ “ 65 – 84%	
C	“ “ 85 – 100%	

Let us cite one actual example. A child is given a B rating if he lifts his head and chest from a mattress at four months, and C if he does not do it until six months. Since the B rating means that over two-thirds of children can do this by four months, the average infant should perform the act before that time; C would therefore suggest a certain amount of retardation in that trait.

Samples of developmental norms are quoted from Gesell in Table 4. By using this brief table or by consulting the full list published in the original book, one can study the rate of development of any child in whom he is interested. Parents frequently try some of these simple tests on their own offspring.

TABLE 4
 SAMPLES OF DEVELOPMENTAL NORMS [7]

FUNCTION	RATINGS*		
Tries to sit up.....	4 C		
Sits with slight support.....	4 A+	6 B+	9 C
Stands with help.....	9 A	12 C	
Stands alone.....	12 A	18 C	
Rolls from back to stomach.....	4 A+	6 B	
Reaches for spoon.....	4 A+	6 B	9 C
Picks up cube.....	4 A+	6 B	
Prefers right (or left) hand.....	6 A+	9 B+	12 B
Scribbles, imitative.....	9 A+	12 B	
Scribbles, spontaneous.....	12 A	18 B	
Copies drawings: circle.....	24 A+	36 B	48 C
cross.....	36 A	48 B	
square.....	48 A	60 C	
triangle.....	48 A+	60 B	
Uses five words.....	12 A+	18 B	
Repeats new words.....	12 A+	18 B	
Names five objects.....	24 B+		
Obeys three simple orders given at once.....	36 A	48 B+	60 B
Repeats four digits.....	48 B+	60 B	
Washes self without getting clothes wet.....	36 A	48 B+	60 B

*A rating is interpreted thus: 4 C means that if the ability is attained at 4 months it merits a C rating.

3. Prediction of Development

We have pointed out previously that there is consistency in the development of any particular child. If he is accelerated in sitting up, he will almost certainly also walk earlier than the average. Gesell has extended this principle and suggested an interesting hypothesis: That the rate of appearance of simpler traits predicts that of the more complex traits to follow later. Therefore, a child who is 25 per cent accelerated in walking should be ahead in later *mental* development by approximately the same percentage.

If this hypothesis were true, it would be extremely valuable in practice. It would then not be necessary to wait until the child were several years old; he could be tested a few months after birth. Such early tests would be of great assistance to people who were planning to adopt a child, for by their use they could make certain that the child's aptitude was at least average. As it is, present tests cannot be used with accuracy until the child has a vocabulary of several hundred words, and a person is therefore taking a certain risk in adopting a child of less than three or four years of age.

But the evidence for the Gesell hypothesis is far from convincing. Shirley, for example, found very low correlations between the develop-

ment of locomotion and vocalization (both speech and the sounds that precede definite language). At the same time, if one compares extreme groups he can find apparent confirmation of Gesell's theory. We see in Table 5 that the children who later turn out to be bright are, as a group, accelerated in attaining motor abilities. On the other hand, the dull are distinctly retarded in the same functions. It also may be seen that advancement or retardation is more pronounced in the more intellectual traits, such as talking, than in motor acts. [21]

TABLE 5

COMPARISONS OF DULL, AVERAGE, AND BRIGHT CHILDREN IN AGES OF ATTAINING MOTOR ABILITIES

FUNCTION	Feeble-minded	Average	Bright
Sit unsupported97 years	.58	.49
Stand unsupported	1.68	1.01	
Take several steps	2.09	1.16	1.09
Use three or more words	3.21	1.28	.95

Here, as often happens in scientific investigations, we find a trend when we compare *averages* of widely different groups, but that trend does not hold for each individual case. In the main, bright children do walk earlier than dull ones, but the actual correlation is weak. And in some cases bright children may actually be retarded in motor activities. Some children are backward in motor development, on the basis of Gesell's norms, simply because they are considerably heavier than other children of the same age. It is quite likely that acceleration in motor activities may be taken as a favorable sign, but retardation has so many possible causes that serious prognostication of intellectual development is not to be recommended. Finally, since correlations are so weak, slight individual discrepancies at an early age may be ignored.

4. Maturation versus Training

We may ask whether the rate of appearance of certain traits, such as walking, cannot be accelerated by special training, instead of appearing at a certain predestined time. Several experiments with animals and with children have dealt with this very point.

(A) PECKING IN CHICKS. One of the best-known studies in the field of animal psychology is that by Shepard and Breed. [24] They started with two known facts: that the chick in the first day picks up about 15 per cent of the grains it aims at, but it attains an accuracy of 70 to 80 per cent by the time it is an adult chicken. What is the cause of this improvement? In this experiment, which demonstrated that

maturation, more than learning, is responsible, chicks were prevented from pecking. They were kept in a dark room and fed with a medicine dropper. Different groups were released after varying periods and were allowed to obtain their food in the customary manner. Their rates of improvement were compared with that of a control group which started to peck immediately after hatching. We can see from Fig. 13 that the delayed groups rapidly caught up to the others and that the older they were the less time they required. We can also recognize the similarity between these findings and those of older children

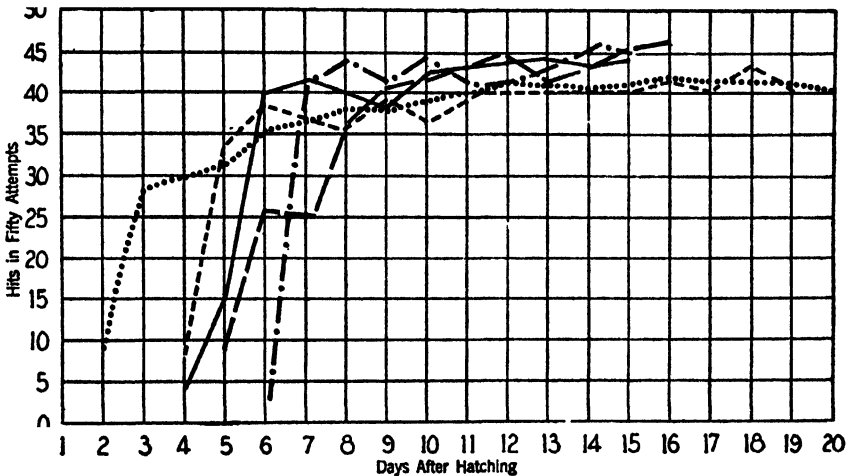

FIG. 13.—Curves of Maturation Showing Pecking Accuracy on the Part of Chickens Who Have Been Delayed Various Numbers of Days Since Hatching.

By the ninth day all groups were equal, even those chicks who had not been permitted any practice until the sixth day. (From Shepard and Breed.)

who are "learning" to walk and rapidly passing through the earlier (simpler) stages.

Further studies have not furnished quite such clean-cut results on the side of maturation. In addition to maturation, some practice helps the chick attain the maximum degree of skill. [1] In the first four or five days, maturation does account for virtually all the improvement, [4] but subsequently practice is not only beneficial but possibly even indispensable. When a certain amount of practice was allowed during one of the first few days after hatching, an earlier attainment of ultimate proficiency was obtained.

Another observation is that delay may not produce such rapid gains as this first study suggested. Groups fed in darkness for six and eleven

days were actually slower in coming to top efficiency than were those which started a day after hatching and those after three days' delay. [20] When a greater delay (sixteen days) was tried, [22] the habit in some cases was not formed at all, and the chickens were inclined to "starve in the midst of plenty." This fact suggests that there may be crucial times for undertaking the formation of certain habits, and that practice either before or after this optimal time is not so beneficial as practice at the appropriate age.

(B) FLIGHT OF BIRDS. Young birds were cooped in cages so small that they could not fly at all, and each bird was isolated so that he could not see others flying, precluding any possibility of learning by observation. When they had reached the age for flying, they were released and flew immediately. They not only kept in the air, but they handled themselves well and performed all the swoops and gyrations of grown birds.

(C) STUDIES OF CHILDREN are more difficult to control than those of animals. With animals, the environment can be controlled. An animal in a cage may be assumed to be almost completely deprived of learning and ordinary environmental experiences. But it has been wisely said that a human being cannot be raised in a vacuum. If we wish to study a person's abilities at fifteen and again at thirty-five, there is more to consider than just the age difference. Much has been learned and experienced in those twenty years.

In human beings it is therefore difficult to determine the proportions of innateness, of maturation, and of learning in any particular behavior. A close approximation can be made, however, by keeping all but one factor constant and then studying its influence. This is a practical application of the simultaneous equation method suggested on page 15.

A clever means of doing this is the "co-twin control" method. Identical girl twins of slightly less than a year of age were selected for one study. Only one of them was given special training, and the two were compared later. If the trained one proved to be better, it would be evidence of learning. But if the twins were equal in spite of the extra training one had, it would show that maturation accounted for all improvement. In this study two tests were used: stair climbing and block building. The trained twin was allowed to practice climbing stairs from the age of forty-six through fifty-two weeks. The untrained twin began with the stairs in the fifty-third week. She soon proved to be as proficient as her sister in spite of less practice. Likewise, the twin who had practiced block building by imitating the experimenter was no better than her untrained sister. The same thing

happened when the twins arrived at the age for acquiring language—about a year and a half. One was given special training for five weeks in naming objects and using words, while the other was kept in a non-verbal environment. When the latter twin was given opportunity to learn words, she learned seven more words in four weeks than her sister had learned in five weeks. [28] Hence we conclude that differences demonstrated in stair climbing, block building, and speech are accounted for by maturation alone, not by learning.

Two studies of slightly older children demonstrated much the same thing. J. R. Hilgard [10] took children from two to three years of age and gave half of them special training in buttoning, cutting with scissors, and stair climbing. After twelve weeks' training, the unpracticed group was given just four days of training, which sufficed to bring it practically to the level of the other group. Jersild [13] attacked a similar problem with children from two to eleven years of age. One group was trained for several months in color naming, word association, strength of grip, strength of back (lifting), lung capacity, tapping speed, and singing pitches and intervals. Both groups were tested before and after training, and also several months afterwards to see if such gains as might occur would be permanent. This study demonstrated that the practiced children did gain in all the tests during training, but that with one exception all such advantage had been lost when the later tests were run. For example, the trained group was faster in naming colors than were the unpracticed children, but several months later the latter group caught up to those who had had more practice, solely because they were growing in ability. The one function in which the gain was permanent was the ability to sing tones and intervals. This particular function, then, is more subject to learning than to natural growth.

Two important studies have been concerned with the problem of the best age at which to begin the instruction of children. The first was conducted by Myrtle McGraw [17] who controlled the environments of twin boys, Johnny and Jimmy, up to the age of about two. Johnny was given intensive training in various acts such as diving, swimming, roller skating, and language usage. Jimmy received no such training but was tested later to see if he would be permanently handicapped, slightly delayed, or not affected by the differences in training.

At first Johnny's performance seemed amazing. At eight months he swam the length of a seven-foot tank, and at eighteen months he swam fifty feet. At fifteen months he took great delight in diving head first from a springboard about five feet high—a feat which many college students hesitate to do. At 350 days he began practice in roller skating

(note that this is earlier than the average age of walking), and when he was still a month short of two years "his mode of action consisted primarily of the broad rhythmical body sway which is characteristic of a proficient skater . . . there was no pause between glides. In other words the act had become integrated." Jimmy, on the other hand, given only occasional experience, solely for the purpose of testing, failed to make any appreciable progress.

If, in the course of tests made months and years later, the two boys demonstrated equal capacities for these acts, the importance of maturation would be proved and Johnny's early training could be considered irrelevant and useless. McGraw made such follow-up studies after the boys had been returned to their family. These strongly support the cause of maturation, inasmuch as Jimmy gradually caught up to the level of his earlier trained twin brother. Early training, then, produced only temporary acceleration, just as in the case of the girl twins in stair climbing and block building.

The second investigation involved the same theoretical problem. It studied the optimal age of learning to play the piano. [2] Eighteen children of five to nine years of age were tested on their ability to play four-measure musical scores, simply arranged in the key of C and with just one note to be played with each hand. The best age appeared to be seven or later. Little was gained by too early a start. It was tentatively concluded that learning under seven is so slow that lessons are largely a waste of time and money, unless the child happens to be a definite musical prodigy.

A complete and final answer would necessitate the testing of large groups of children up to twelve or thirteen, but it is safe to say that the more complex the task the more advisable a late start becomes. Children in grades three to six consume immense amounts of time in learning simple arithmetical processes, their history lessons are much diluted, and geography is repeated from grade to grade. As one concrete example: percentage computation may be taught to an adult in fifteen minutes; yet the seventh- or eighth-grade child is given two or three weeks of training to acquire it. Because it was found that square root is difficult to understand during grade school years, it is now quite generally delayed until high school.

III. LEARNING IN THE FIRST FEW YEARS

1. The Importance of Learning

Learning starts the instant the individual becomes an independent organism—that is, right after birth—and continues as long as he lives.

Relatively speaking, the young child learns much more in any given period of time than does the adult. Everything is new to him. He is born with no knowledge, no information, no body of experience. At the age of six, when he enters school to begin his formal learning, he already has a vocabulary of a couple of thousand words, can carry on simple reasoning, is acquainted with many people, and has found out many things about his society and its modes of conduct.

In this chapter we shall describe briefly how the child develops certain important functions. Some of these topics will be treated in more detail later as we discuss the origins of adult behavior.

2. Motor Learning

When we examine the development of motor traits we are more involved with maturation than with genuine learning. We find that a child of ten can throw a ball farther than one of six, that he can learn to swim in fewer lessons than his younger brother, and that he acquires all sorts of motor skills with greater rapidity and a higher degree of final skill. Motor abilities improve at least up to the traditional age of maturity—twenty-one, and possibly up to thirty.

Motor learning can begin right after birth. In one experiment, eight newborn infants were given the bottle directly after a buzzer had been sounded for five seconds. [15] By the time they were four or five days old they demonstrated that an association had been formed by opening their mouths, performing sucking movements, and decreasing other activities. Obviously the buzzer is an artificial stimulus; without definite learning only the breast or the bottle would produce sucking movements.

Several theories have been advanced to account for play. One theory is that play serves as a preparation for future activities and is planned by "Nature" to develop strength and skill for subsequent use in practical affairs. We cannot deny that play has this value, but it seems to be reasoning backwards to say that this is the only reason a child plays. It is more likely that, since he has no duties beyond a few hours of school a day, and is not yet engaged in anything of a serious nature, he plays because he has surplus energy. The result may be the same; he does gain strength and skill, but the latter explanation is more reasonable scientifically.

3. Handedness

There are few topics in psychology about which there has been more argument and less agreement than the origin of right-handedness. Parents and teachers both want to know whether the child who shows

signs of becoming left-handed can or should be changed to use his right hand. The decision hinges upon whether handedness is innate or acquired. [23] An overwhelming mass of evidence suggests that one is born with a slight predisposition toward preferring one hand, but that usually the preference may be changed over without much difficulty if training is started early enough.

From 5 to 10 per cent of people are classed as left-handed, but no one is completely right-handed or completely left-handed. The left-handed person is forced by social pressure to develop the use of his unskilled hand to a greater extent than is the right-handed individual. He shakes hands, shifts gears in an automobile, uses certain tools, and may even write with his right hand. But the right-handed person may have some specific left-hand skills. One may catch a baseball with the left hand and feel definitely awkward if he tries it with the right.

Several facts suggest that handedness is to some extent innate. Tools and drawings of primitive man indicate that he was right-handed. Animals show a tendency in the same direction, although the predominance is not as great as with human beings. When a group of rats was forced to pick up food with just one paw, two-thirds preferred the right. [30] Monkeys exhibit the same tendency. They use the right hand more often in difficult skilled acts than in routine habits. [14] Finally, hand preference seems to run in families. Some have many left-handed members, others none. In spite of the fact that thousands of cases in many families have been tabulated, no definite ratio or sequence of inheritance of this trait has been established.

The difficulty of change is indirect evidence of innateness. A college girl reports her own case:

When I was about a year and a half old I was already left-handed. One day I fell and broke my left arm, and of course it had to be put into splints for several weeks. My mother hoped and expected that being forced thus to use my right arm solely for that time, at that young age, I would become right-handed. But the minute the splints were removed I went right back to being left-handed. My mother constantly tried to make me change, but naturally couldn't prevent my using the left hand when I was out of her sight.

Of course, the result might have been different if a well-trained psychologist had been in charge, and if efforts had been started earlier and continued longer.

Up to six months of age the two hands are used equally. If the infant is seated in a high chair and a piece of candy is shoved slowly toward him on a line with the middle of his body, he will appear

ambidextrous. Several studies have investigated the percentage of right-handedness at various ages and show in general that, while just 50 per cent prefer the right hand at six months, 70 per cent have a preference at one year of age, and 90 per cent, practically the adult figure, at two years. [6, 31]

Handedness is closely tied up with the side of the brain and the eye used most frequently. The left side of the brain controls the right side of the body, and vice versa. The more complex intellectual activities are allied with these motor functions. For instance, if you are right-handed, not only are skilled acts controlled by the left hemisphere, but language associations become centered in that area. Hence, a person not only eats, throws, and writes right-handed, but in a sense he also thinks right-handed. About two-thirds of all people are right-eyed, also. When one is forced to sight with one eye or the other (not both) the majority of people use the right, and practically all are consistent. [18]

It is well known that a forced change of handedness often results in stammering. [29] The child is forced to use his less skilled hand, and with it the less skilled side of the brain. Whether the stammering is emotional or neural in causation we do not know. That it may be largely emotional is suggested by the fact that speech disorders do not invariably occur, but they occur often enough to demonstrate the riskiness of a change in handedness. At the University of Iowa it was discovered that approximately 30 per cent of stammerers had had their original handedness changed. Stammering has occasionally been cured by allowing a person to return to left-handedness.

Jack was a college junior who had such serious speech difficulties that he could not recite in class or even complete a single sentence without one or more blockings. He was changed to left-handedness and six months later a number of strangers who spent the evening with him failed to notice any speech difficulty at all. His suggested change included not only writing, but combing his hair and all other skilled acts.

On the basis of such evidence we may ask the question: Why attempt to force conformity? Left-handedness is not like leprosy, something to be stamped out. The only possible justification for change is that the left-handed person is somewhat handicapped in certain situations. Writing chairs have the extension arm on the right side, shears squeeze best with the right thumb, watches wind more readily with the right hand, and controls on some machinery are placed on the assumption that the user will be right-handed. It is difficult if not virtually impossible for a left-handed person to become a dentist. But all these

are minor points, as compared with the difficulty of effecting a change and the possible harm involved.

If a parent still persists in wanting to make his child right-handed, it is strongly to be recommended that the child be so guided when he shows the first signs of preference, usually between the ages of six months and one year. This is before he learns speech, writing, or any complex manual habits. Because of evidence pointing toward the in-nateness of handedness and the risk involved in forcing a change, it is wiser not to attempt to change the child.

These points do not mean that an adult cannot successfully change handedness. In cases of crippling injury to the skilled hand, the adult must learn to use the other, but this is different from arbitrarily forcing a child to use the less preferred hand. A doctor who lost his right arm in middle age learned to remove tonsils and perform other operations with his left. A baseball player whose arm had healed badly after a break learned to throw so well with his left that he became one of the best throwing outfielders in the big leagues. Many basketball players shoot with either hand. It does not take many hours of practice to attain fair skill in eating, throwing, or writing with the unskilled hand.

4. Language and Thought

(A) SPEECH. The average child uses a few words at eighteen months and adds several hundred words each year. The wide variations in extent of vocabulary are due to intelligence, quality of social environment, and inexplicable individual differences. Environment is impor-

TABLE 6
SIZE OF VOCABULARY OF PRESCHOOL CHILDREN [27]

AGE		WORDS
2	years, 0 months	272
2	6	446
3	0	896
3	6	1,222
4	0	1,540
4	6	1,870
5	0	2,072
5	6	2,289
6	0	2,562

tant; the better educated and more literary the child's parents, the wider will be his vocabulary. In Table 6 we quote the extent of recognition vocabulary of a group of children who happened to have intelligence scores about equal to that of the average college student; therefore the figures will be typical of the reader for any given age.

The first verbal associations are often helped along by adults from

sounds babbled by the infant: "mama," "dada," "wawa" (water). Other words are soon learned, nouns for the most part, and are used singly to convey complete meanings. Adults rarely express meaning by a single word alone, although some of us hand a movie theater cashier a bill and merely say "Two." By the time the child is two years old, just half a year after speech begins, his average sentence contains two words, customarily a noun and a verb: "Bring water," "Dolly broke." Later stages include the addition of adjectives, pronouns in place of names, and other minor parts of speech. [3,16] These stages will be discussed when we deal with the development of thought in Chapter XXI.

The use of more and more complex language forms gives evidence of increasing depth and complexity of thought processes. The use of a subordinate clause indicates that things are not absolute: "We will skate tomorrow, unless it thaws." The forming of generalizations is another step. Children under five are unable to pick the common element from four trays containing respectively a dog and a bird, a dog and a pig, a dog and a cow, a dog and a sheep. More abstract generalizations, such as "In what way are bread and meat alike?" are approached at eight years of age.

Self-criticism represents an even more advanced stage. The child is usually too well satisfied with what he has done to find fault with it before he is at least six years of age. Even with adults, self-criticism is considered to be one of the marks of intelligence.

(B) IMAGINATION. Imagination of a high degree is another characteristic of the thought processes of children. The child who straddles a broomstick and gallops around the yard is really riding a horse. He is not pretending as is the adult when he plays charades. His toys are real objects which may be changed as the situation demands, and his playmates may range from heroes to criminals. Although it does not hold true in every single case, children's dreams are more frequent and more vivid than those of adults. The older we become the fewer dreams we have. Many adults have hardly any, and the ones they do have are inclined to be less realistic and vivid.

(C) ATTENTION. The ability to sustain attention grows as one grows up mentally. This is reflected in the length of class periods at different educational levels. In grade school the class periods run twenty or thirty minutes; in high school the usual duration is forty minutes; college periods are of fifty minutes, with graduate seminars up to two hours. The distractibility of young children is often used practically. Their minds can readily be turned from one subject by the substitution of a new interest.

5. Personality and Social Development

Personality traits are almost entirely acquired, their development starting long before the infant has developed either locomotion or speech. He may be spoiled and lifelong habits of selfishness developed by being made the center of all activities in the home. If the parents run to his crib every time he utters a sound, he will use that device to secure attention whether or not he is in genuine physical distress. Much of his crying is merely an expression of excess energy and not at all indicative of anything wrong. Parents who wish to train their children to be independent will rightly leave them alone for an hour or two at a time. One hesitates to ignore a crying child, possibly in actual distress, but if he is not in pain he should occasionally be allowed to expend his pent-up energy.

As with any habit system, it is wise to train the child early in conformance with customs of society. A well-established undesirable habit persists strongly and resists efforts to substitute a more desirable one. There is probably a limit to what can be expected from training. The child may be taught certain specific habits, such as watching out for little brother or running errands for grandmother. But "boys will be boys" and not little men with adult manners. Social personality traits are subject to maturation as well as to learning. Parents should remember this, and not become exasperated at recalcitrant behavior or consistent failure to follow instruction.

Genuinely social behavior is slow in developing. Up to about three years of age the child is a sturdy individualist. He is a despot, thinking of other people only in terms of himself. So far as he is concerned, his parents exist solely to serve him. He would not think of doing anything for them in return.

Between three and twelve there is an intermediate stage. His ability to walk and talk enables the child to become an integral part of society. He is more concerned with other people than heretofore, but it cannot be said that he has the social outlook of an adult. Adults usually return a favor done them, feel sympathy toward others, and help friends who have had reverses.

But watch children playing a game. Even though group participation is necessary, there are constant shouts of "I want to be captain," or pitcher, or batter, or the pursued side in "cops and robbers," or whatever role gives the ego most play. If there is compromise at all, it is for purposes of later gain. As we have seen, the experiment comparing the social cooperation of monkeys and children verified these conclusions.

CONCLUSIONS

1. *Birth equipment.* An inventory of the child's birth equipment is necessary before we can trace his development to adult status. We find few truly hereditary psychological traits. Family resemblances are due almost entirely to learning and social imitation.

Native equipment cannot be catalogued in any clear-cut fashion. Reflexes and random movements lack precision and coordination, as to both elicitation and manner of expression. At birth, sensory capacities are likewise undeveloped and not as well differentiated as they will be in a few months. Finally, emotions are few and diffuse.

These facts give further weight to our major theme, the Genetic Viewpoint; namely, that development and learning are of prime importance in virtually every psychological topic. The less equipment we find present at birth, the more must be acquired during childhood and adolescence in order that the individual may arrive at an adult status.

2. *Maturation.* The functions classed under the heading of maturation are really part of innate equipment, but they are delayed in appearance, in some instances for many years after birth. This delay in maturation proves that the organism is not complete at birth, but that it keeps on developing apart from the mother and independently of learning. Certain abilities appear after a period of time, regardless of the child's training or environment.

This principle poses some practical problems. Suppose a parent wishes his child to be a good pianist, golf player, or chess expert. He is tempted to start the child at a very early age and to force him to practice as much as possible. Is this wise? Will it produce results? All the best evidence strongly suggests that below a certain age such efforts are largely wasted. It is doubtful, for example, that a boy of thirteen who had had five years of instruction and practice would be a better golfer than another boy of equal potential skill who had had only a year of the same training beginning at twelve. Most of the improvement between eight and twelve is attributable more to maturation than to coaching. Advisable ages for starting will have to be ascertained for each activity; no universal recommendations can be made.

Lest these last remarks mislead the reader, let us sound a strong note of caution. Possibly the reader has noticed that we have been talking for the most part about motor functions. It is in this field that maturation is of prime importance. But the concept of growth from within does not extend into many phases of human behavior. We shall see that learning is far more important in the great majority of cases. The

earlier personality development is started, the better. Efforts to control situations conducive to fear and anger should be instituted before such emotions are firmly established. Table manners, use of correct grammar and pronunciation, and many other habits are entirely acquired.

3. *Early learning.* Despite the importance of birth equipment and maturation in the development of some human capacities, learning plays the largest role in the attainment of adult mental status. Learning starts immediately after birth, and continues constantly and indefinitely. It applies to all fields of behavior: motor skills, language, personality traits, social development, and emotions.

Briefly we have traced learning and growth in these fields from infancy to adolescence. We have seen, and shall continue to see, the importance of this early learning. It establishes habits, skills, and outlooks which have strong and permanent influences upon the adult's life.

REFERENCES

1. Bird, C. Maturation and practice: their effects upon the feeding reactions of chicks. *J. comp. Psychol.*, 1933, **16**, 343-366.
2. Brown, R. W. The relation between age (chronological and mental) and rate of piano learning. *J. appl. Psychol.*, 1936, **20**, 511-516.
3. Bühler, K. The mental development of the child. New York: Harcourt, Brace & Co., Inc., 1930.
4. Cruze, W. W. Maturation and learning in chicks. *J. comp. Psychol.*, 1935, **19**, 371-409.
5. Curti, M. W. Child psychology. New York: Longmans, Green & Co., 1930.
6. Downey, J. E. Laterality of function. *Psychol. Bull.*, 1933, **30**, 109-142.
7. Gesell, A. Infancy and human growth. New York: The Macmillan Co., 1928.
8. Gesell, A. The mental growth of prematurely born infants. *J. Pediat.*, 1933, **2**, 676-680.
9. Gesell, A., & Thompson, H. Learning and growth in identical infant twins. *Genet. Psychol. Monogr.*, 1929, **6**, 1-123.
10. Hilgard, J. R. Learning and maturation in preschool children. *J. genet. Psychol.*, 1932, **41**, 36-56.
11. Jensen, K. Differential reactions to taste and temperature stimuli in newborn infants. *Genet. Psychol. Monogr.*, 1932, **12**, 361-479.
12. Jersild, A. T. Child psychology. New York: Prentice-Hall, Inc., 1935.
13. Jersild, A. T. Training and growth in the development of children. *Child. Developm. Monogr.*, Teachers College, Columbia Univ., 1932, No. 10.

14. Kounin, J. S. Laterality in monkeys. *J. genet. Psychol.*, 1938, **52**, 375-393.
15. Marquis, D. P. Can conditioned responses be established in the newborn infant? *J. genet. Psychol.*, 1931, **39**, 472-492.
16. McCarthy, D. The language development of the preschool child. Minneapolis: Univ. Minn. Press, 1930.
17. McGraw, M. B. Growth, a study of Johnny and Jimmy. New York: D. Appleton-Century Co., Inc., 1935.
18. Miles, W. R. Ocular dominance demonstrated by unconscious sighting. *J. exp. Psychol.*, 1929, **12**, 113-126.
19. Morgan, J. J. B. Child psychology. (3rd ed.) New York: Farrar & Rinehart, Inc., 1934.
20. Moseley, D. The accuracy of the pecking response in chicks. *J. comp. Psychol.*, 1925, **5**, 75-97.
21. Murphy, M. The relation between intelligence and age of walking in normal and feeble-minded children. *Psychol. Clin.*, 1933, **22**, 187-197.
22. Padilla, S. G. Further studies on the delayed pecking of chicks. *J. comp. Psychol.*, 1935, **20**, 413-443.
23. Schiller, A. Theories of handedness. *J. appl. Psychol.*, 1935, **19**, 694-703; 1936, **20**, 77-92.
24. Shepard, J. F., & Breed, F. S. Maturation and use in the development of an instinct. *J. Anim. Beh.*, 1913, **3**, 274-285.
25. Sherman, M., & Sherman, I. C. The process of human behavior. New York: W. W. Norton & Co., Inc., 1929.
26. Shirley, M. The first two years. Minneapolis: Univ. Minn. Press, 1931. Fig. 20 from Vol. II; Table 2 from p. 99, Vol. I; Table 3 from p. 26, Vol. II.
27. Smith, M. E. An investigation of the development of the sentence and the extent of vocabulary in young children. Iowa City: Univ. Iowa Stud. in Child Welfare, 1926.
28. Strayer, L. C. Language and growth. *Genet. Psychol. Monogr.*, 1930, **8**, No. 3.
29. Travis, L. E., & Johnson, W. Stuttering and the concept of handedness. *Psychol. Rev.*, 1934, **41**, 534-562.
30. Tsai, L. S., & Maurer, S. "Righthandedness" in white rats. *Science*, 1930, **72**, 436-438.
31. Watson, J. B. Behaviorism. New York: W. W. Norton & Co., Inc., 1930. Chapters V and VI.

NEURAL AND SENSORY PROCESSES

cortex. One region deals with the primary act of visual reception and perception, while surrounding areas mediate associations and memories. Thus we see from one function how many parts of the nervous system may be involved.

(B) **THE NEURON IS THE STRUCTURAL UNIT OF THE NERVOUS SYSTEM.** The structural unit of the nervous system is the neuron, which consists of the cell body and its processes, the axon, and the dendrites. The axon is usually long and conducts impulses *away* from the cell body. Each neuron usually has one or more dendrites which conduct impulses *toward* the cell. The surface interfaces between the axons of one cell and the dendrites, or the cell body, of the next form a synapse (junction), and impulses are conveyed from one neuron to another in this direction.

(C) **THE REFLEX ARC IS THE FUNCTIONAL UNIT OF THE NERVOUS SYSTEM.** In any bit of behavior several neurons are connected to each other functionally. The simplest response must involve two neurons, one from the sense organ which picks up the stimulus and the second to the muscle; usually at least a third neuron, a connector neuron between the sensory and motor neurons, is involved. Such a simple sequence will apply only to the simplest types of action, such as leg withdrawal in the dog. In an act of medium complexity, we have hypothetical connections approximately as shown in Fig. 14.

(D) **NATURE OF THE NERVOUS IMPULSE.** The impulse is a physicochemical process, traveling along the nerve trunk much like the flash along a train of gunpowder. One wave follows another, with a recovery (refractory) period of about a thousandth of a second. The speed of nerve conduction varies according to the type and size of the trunk. In the large motor and sensory trunks of a human being the speed may be 200–300 feet a second, but in the smaller nerves it may be as little as a hundredth of that rate.

2. General Anatomical Organization

(A) **PERIPHERAL AND CENTRAL NERVOUS SYSTEMS.** The two chief divisions are the peripheral and central nervous systems. The central system contains the brain (neural tissue within the skull) and the spinal cord. The peripheral system is made up of the nerves and nerve centers outside these two parts. In the main the latter is composed of nerve fibers going to the muscles and coming from outlying sense organs.

(B) **THE PARTS OF THE CENTRAL NERVOUS SYSTEM.** These parts are listed briefly below, and will be discussed more fully in the next few pages.

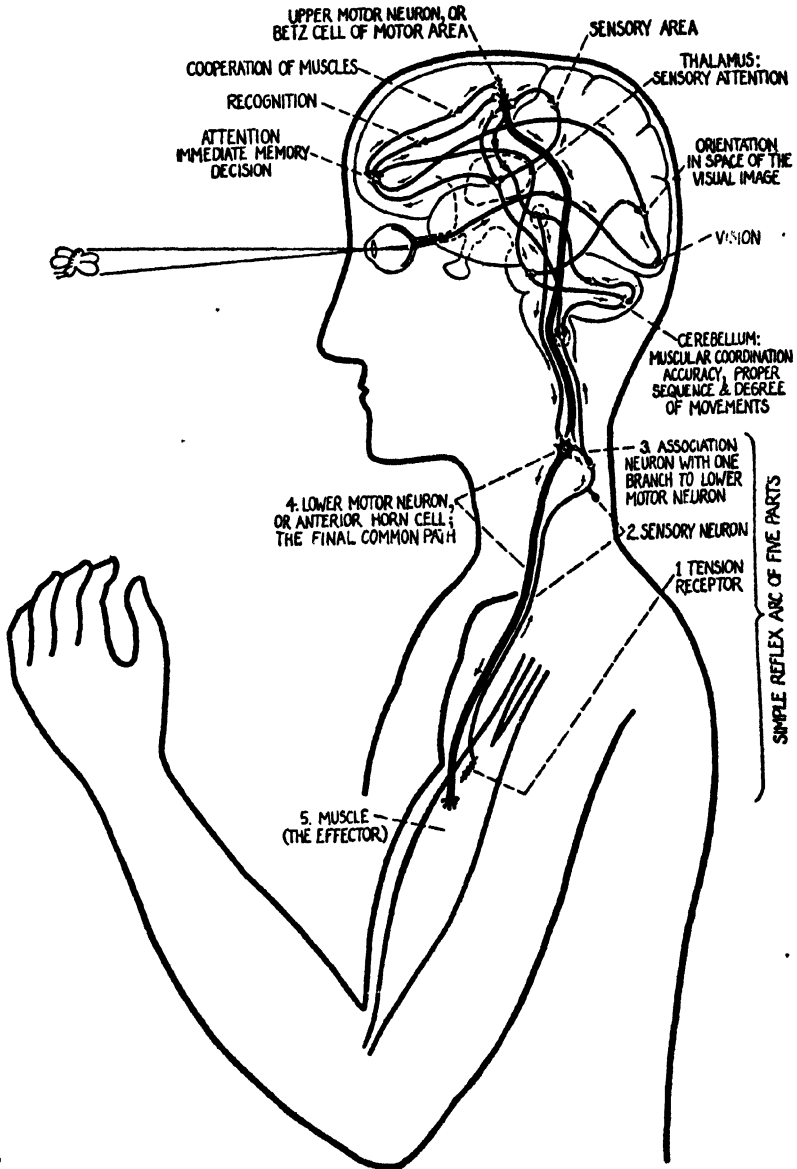

FIG. 14.—Connections Involved When One Sees a Bee about to Sting and Slaps It.

First there are the visual connections, then coordination within the appropriate regions of the brain, and finally several relays through the motor centers before the muscular response is made. A typical reflex arc is also shown.

(1) *Spinal cord* is the reflex center and pathway between the brain and the remainder of the body.

(2) *Medulla*, where the spinal cord enters the skull, expands and forms centers for control of vital functions, such as heartbeat, breathing, blood pressure, digestive movements, and some of the cruder sensorimotor reflexes. Also it serves as a pathway between the higher centers and the spinal cord.

(3) *Cerebellum* lies at the base-rear of the skull, and is off the main line from lower to higher centers. Its function is mainly that of reinforcement and coordination of voluntary movements.

(4) *Midbrain* contains the next higher group of nuclei beyond the medulla. It mediates automatic functions of posture and balance, and sensorimotor reflexes such as eye-wink and pupillary contraction.

(5) *Thalamus* is the greatest integrating center of the brain, below the cerebral hemispheres. Crude touch, pain, smell, and taste impulses are here coordinated and impulses relayed to appropriate motor centers. The thalamus undoubtedly has significance in emotion, but the exact nature of its function has been the subject of bitter dispute. This controversy will be touched upon in Chapter IX.

(6) *Cerebral hemispheres* form a great expansion and overgrowth from the lower brain centers. From the thalamus, great tracts radiate outward in different directions to the surface of the cerebral cortex, which in man and primates has completely surrounded the other parts. This is the center for the highest intellectual functions, voluntary movements, complex sensory and perceptive processes, associations, and consciousness.

3. Spinal Cord

A typical reaction has three neural components: an afferent, or sensory nerve, leading from receptor (sense organ) to the central nervous system, a central connection of greater or lesser complexity, and an efferent, or motor trunk. Some simple responses may involve nothing more than transmission across the spinal cord from afferent to efferent nerves. But the majority ascend the spinal cord, are shunted around in the higher centers, and descend through the motor tracts.

Even though the spinal cord is no thicker than one's little finger it contains at least two dozen tracts. Some of these are sensory (ascending) and some are motor (descending). Typical disorders follow lesions of one or more of these tracts.

Spastic paralysis, characterized by stiff and jerky movements, is a motor disorder caused by birth injury or other damage. Impulses which normally

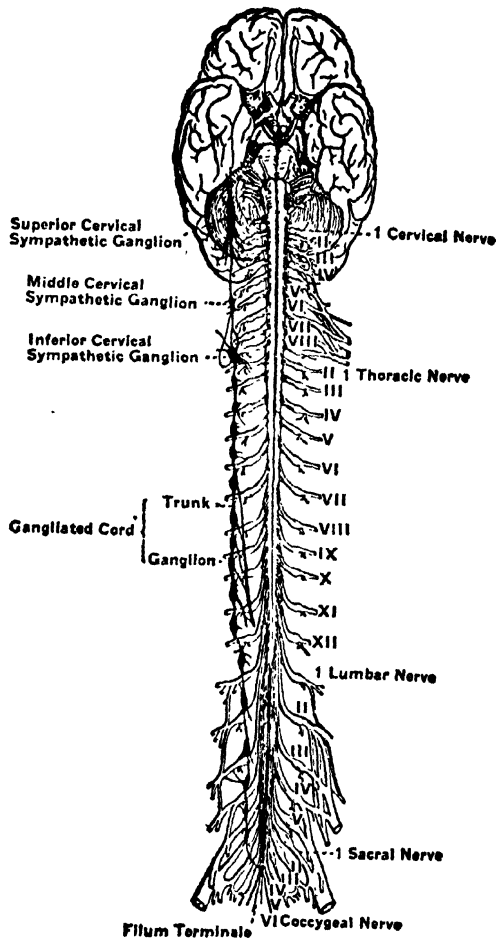

FIG. 15.—Cerebrum and Spinal Cord.

This diagram serves chiefly to illustrate how the spinal cord emerges from the brain, and how the nerve trunks emerge to supply various parts of the body. (From Herrick, p. 115.)

produce integrated muscular movements come down several tracts, and if one or more tracts are blocked there is failure to achieve the necessary tensions and relaxations of the different muscle groups.

Flaccid paralysis, such as follows infantile paralysis, is produced by destruction of the nerve cells of the neurons leading directly to the muscles, which prevents nervous impulses from reaching the muscles. There is loss not only of ability to react voluntarily, but muscular tonus also is abolished.

Tabes dorsalis, or locomotor ataxia, is a sensory disorder. The motor tracts may be unaffected. The patient loses his ability to identify the position of his limbs, and consequently suffers incoordination. His movements become jerky, exaggerated (such as too high lifting of the feet), and imperfectly controlled. If blindfolded he cannot place his finger on the tip of his nose or place the heel of one foot on the toes of the other, since without vision he is no longer able to realize the location of his nose or toes.

When the spinal cord is completely severed, there is paralysis and anesthesia of all organs below that point. If severance occurs in the neck region, as from a diving accident, death usually occurs quickly from respiratory failure. If the break is lower, the patient suffers paralysis of leg and trunk muscles, and loss of visceral functions such as circulation and elimination.

4. Cerebellum

The chief function of the cerebellum is to reinforce voluntary movements, such as walking, speaking, and balancing. Apparently the cerebellum does not initiate movement. In cases of cerebellar injury the individual shows disturbance of ability to effect smooth, coordinated, voluntary movements. There is no loss of any single movement; rather the deficiency is in smoothness of execution. Here is a typical case:

Patient cannot walk easily, or even in a straight line. In fact several times he has been arrested for drunkenness as he weaved from one edge of the sidewalk to the other. He sits down heavily; he does not check himself and ease down the last few inches. If he is laid on his back and a leg raised in the air and then dropped, it hits the bed with a thud. He cannot stop it. He has difficulty pointing to the end of his nose with his eyes shut. Speech is somewhat impaired, especially with long words or tongue-twisters such as "Methodist-Episcopal" or "artillery brigade," unless each syllable is pronounced slowly and carefully. Another characteristic symptom is that the patient cannot perform this act: place the hands palm downward side by side on a table; quickly flip them onto their backs, then back again to the palms, etc. After two or three such rapid alternations the timing coordination is lost and the hands not only lose simultaneity but also begin to fly about rather wildly.

It is probable that this case represents an extensive lesion, or injury, because, owing to the homogeneous functioning of the entire cerebellum, a small lesion may exist without noticeable impairment of any function. Prospects for recovery of normal coordination are good if the injury is not extensive or progressive.

5. Midbrain and Thalamus

The midbrain is the next higher center on the main highway from the spinal cord to the cerebral cortex, and lies above the medulla. As in the case of other intermediate centers, it serves to mediate acts which do not require conscious intervention (semi-automatic motor coordinations), and also to relay impulses upward or downward. It aids in the coordination of fairly complex reflex adjustments, enabling the organism to maintain a semblance of normal posture.

The thalamus is an integrating center just below the cerebral cortex itself. It probably mediates a sort of crude consciousness of pain, pleasure, extremes of temperature, and crude contact.

The thalamus has been postulated also as the center of normal accomplishments of emotions. This may be partially tied up with the sensory functions of the organ, since in some lesions an exaggerated sensitivity follows. A pencil drawn flat and gently across the face may feel like sandpaper or a razor, a slight noise may seem unbearably shrill, music may make one uncontrollably sad or happy. There may also be emotional anomalies. Patients may laugh at a funeral or cry at a witty remark.

6. The Cerebral Cortex

The cerebral hemispheres have reached their highest development in land mammals. In organisms below that level the lower sensory and motor centers suffice for the majority of activities. Actually, from a knowledge of the human brain, it is possible to identify the major parts of a rat's brain or vice versa. The cerebral hemispheres of an anthropoid ape are strikingly similar to those of man.

A point of great importance is that discriminative mental activity occurs only on the surface of the hemispheres. From underlying parts projection fibers and association tracts lead impulses to the appropriate parts of the surface. This means, in general, that the organism is capable of original mental activity only in proportion to the area of the surface of the cerebrum. Accordingly, "Nature" has worked out a neat trick in our brains. Because of excessive weight it was impracticable to gain flat surface by enlarging the skull. But area was gained by folding the surface layers into deep fissures. In the human being only about a third of the true surface of the brain is apparent. This may be seen by inspecting Fig. 16.

Another important point is that equal cerebral damage has more serious effects as we ascend the evolutionary scale. Animals with a comparatively small cerebrum can suffer removal of a fair-sized area

without severe functional losses. In the three accompanying tables we show the losses in various species for different functions with removal of all or part of the cerebral cortex.

TABLE 7

POSTURAL RESPONSES IN THE ABSENCE OF THE CEREBRAL CORTEX

ANIMAL	OBSERVABLE LOSS
Frog	None
Pigeon	None
Rat	Slight
Cat	Fairly normal posture; could walk
Dog	Standing and walking possible
Monkey	Sit with help, no progression
Man	Almost complete loss

TABLE 8

LOSS OF HABITS IN THE ABSENCE OF THE CEREBRAL CORTEX

ANIMAL	OBSERVABLE LOSS
Goldfish	Little, if any, loss
Pigeon	Transient loss of memory, new automatic habits readily formed
Rat	Simple habits able to be formed
Dog	General habits formed
Monkey	No evidence for learning
Man	No evidence for learning

TABLE 9

VISUAL RESPONSES IN THE ABSENCE OF THE CEREBRAL CORTEX

ANIMAL	OBSERVABLE LOSS
Frog	No loss
Pigeon	Apparently a slight loss
Rat	Detailed pattern vision lost; brightness discrimination not so good
Cat	Same losses as with rat
Dog	Same losses as with rat and cat
Monkey	Brightness discrimination only partially retained; detailed pattern vision lost
Man	All visual sensations lost

These facts will have additional significance when we turn to a discussion of localization of various functions within the cortex.

7. Functions of the Lobes

The cerebral cortex is divided into four lobes: frontal, parietal, temporal, and occipital. Parts of each of these lobes mediate known specific functions, whereas the functions of other areas are either less definite or less precisely determined.

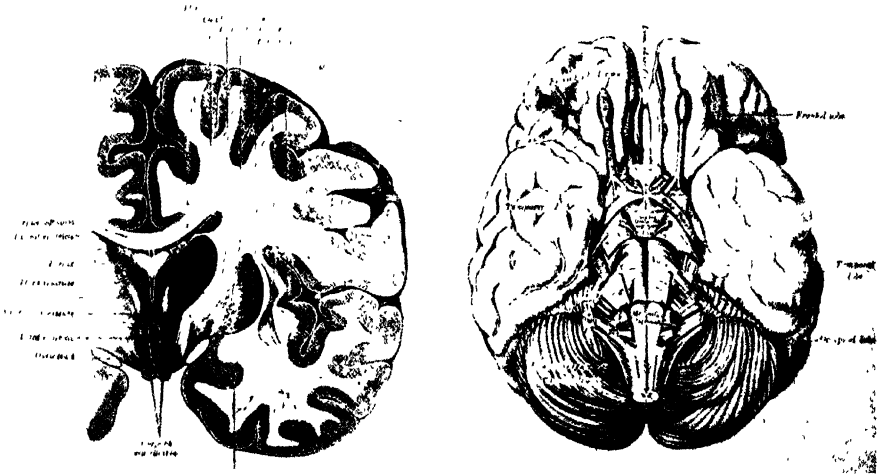
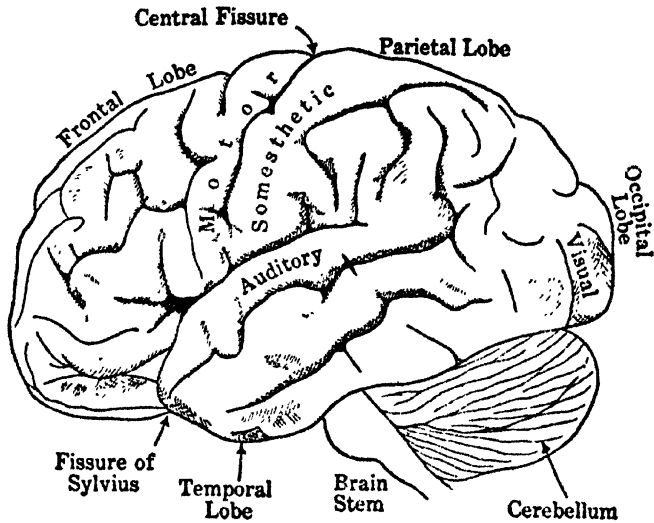

FIG. 16.—(lower left) Vertical transverse section of the human brain.
The foldings of the surface gain surface area.

FIG. 17.—(top) Lateral (side) view of the left cerebral hemisphere, with the principal areas described in Chapter IV located.

FIG. 18.—(lower right) Underside of the human brain.

Many of the lower centers are shown as well as the undersides of the lobes of the cerebral hemispheres.

(A) **FRONTAL LOBES.** As the name suggests, these lobes are in the frontal part of the brain. The extreme front part has been enormously expanded in man and constitutes one of the most striking differences between man and apes. The frontal lobes have four major functions: *motor activity, motor coordination, motor speech, and highly complex associational processes.*

(1) *The motor area* lies in the frontal portion of the prominent fissure of Rolando. The locations of areas initiating motor functions of the various parts of the body are shown in Fig. 17. A general idea of the geographical arrangement is easy to remember when one notes that the locations are upside down from those of the standing human being. The feet are innervated by tissue at the top, the facial muscles are activated by neural tissue near the bottom of the area. Electrical stimulation of this area gives rise to coordinated functional responses such as movements of the thumb and index finger, or of several fingers, rather than to twitches of single muscles. In other words, we have the coordinated responses of several muscles working together.

(2) *Premotor areas* are directly in front of the motor areas. These regulate complicated movements of a more generalized type. Skilled motor tasks require delicate coordination and accurate timing, and such acts as shaking hands, typing, and pole vaulting demonstrate synchronization of many single acts. A person who suffers a lesion in the premotor area loses ability to type words and sentences smoothly. Even walking, usually considered an automatic function, is affected.

(3) *Motor speech* is regulated in Broca's area, named for its discoverer. This is closely connected to that portion of the premotor which regulates the muscles governing speech. Lesions in this region cause disturbances of speech, such as slowness, poor articulation, and omission or elision of adjectives, adverbs, suffixes, and prefixes. Hence meaning must be conveyed by the simplest possible verbal forms, such as are normally used in telegrams. Broca's area appears only in rudimentary form in species below man. This accounts for the inability of animals to speak, in spite of their capacity to understand some words and to utter emotional cries. The reader should notice that this area concerns only the *motor* aspects of speech; an affected individual can still understand spoken words and written language.

(4) *The prefrontal areas*, lying at the extreme front of the frontal lobes, are presumed in the main to carry out complex intellectual functions. Since these cannot be elicited by direct stimulation, we must rely upon evidence derived from pathological cases, such as tumor or accident. Experimentation with animals can be better controlled, but results cannot be transferred to man without qualification.

The losses from prefrontal destruction are both intellectual and emotional, but it is difficult to assert what the effects of such destruction are, especially when it is not very great in extent. In many daily life situations there may be no detectable mental deterioration. A man acted as governor general of a foreign colony for several years after a sizable portion of his right hemisphere had been removed.

Recent careful work, however, has suggested that daily life situations or even intelligence examinations may not be critical enough tests to detect all of the losses in mental abilities. A woman who has lost some cerebral tissue may still be able to keep house, but close inspection may reveal that she is not so efficient as previously. A man may still hold down his job, but his company may assign him simpler work or overlook shortcomings in view of his misfortune, so it is hard to estimate whether or not vocational competence has persisted. Loss of even a small amount of tissue may cause inability to carry on some of the highest mental processes, such as generalization. The patient, for instance, might use a saucer for table use as previously, but would no longer be able to see its possible use as an ash tray; a heavy book might not be thought of as a possible book end; the resemblance between two round objects might not be noticed.

In daily life, it is often noticed that the patient is no longer able to hold in mind the various parts of a complex problem and to see the essential relationships. A woman might still be able to cook each dish well, but be unable to prepare a meal efficiently, since that necessitates having everything ready at one time, keeping in mind the time each dish requires to cook, and so on.

Certain personality alterations may also follow. The individual may show less initiative, be easily distracted, have difficulty maintaining concentration, and be carefree and indifferent to responsibilities. Other manifestations are a loss of restraint, often leading to boasting, selfishness, and inept humor. Impairment in the social and moral fields may also occur.

(B) PARIETAL LOBES. The parietal lobes lie at the top ("parietal" means "roof" in Latin) of the head, behind the frontal lobe. Their primary function is to receive sensory impulses, chiefly of touch and body position. As we see from Fig. 18, the sensory and motor areas are parallel, separated by the fissure. The more discriminative sensations are dependent upon activation of this area; cruder ones are mediated at the thalamus. Destruction demonstrates that the parietal lobe is responsible for perceptions of the qualities of objects, such as discriminations of size, shape, weight, texture, and positions of limbs in space. Injury of the non-primary area affects more complex func-

tions, such as comparisons. One may recognize that an object is warm or rough, but he cannot tell which of two objects is warmer or rougher.

(C) **TEMPORAL LOBES.** The temporal lobes are the centers for audition and auditory associations. The primary center for hearing, to which direct connections lead from the inner ear, lies buried in the lateral fissure in the upper part of the temporal lobes. If this were destroyed the person would lose auditory sensations. It is uncertain what effects would accompany destruction of the rest of the lobe. Supposedly these other areas mediate associations connected with audition, such as recognition of spoken words, musical melodies, and memories for auditory experiences. Taste and smell are probably localized in underlying portions of this lobe, but are not represented on the surface.

(D) **OCCIPITAL LOBES.** The occipital lobes lie at the rear of the brain, and contain the centers for vision and visual associations. Destruction of the primary center will result in total loss of vision. The surrounding areas are essential to visual associations such as memories of scenes, faces, and written language. Electrical stimulation of the surface of the exposed occipital lobe has been known to cause in the patient flashes of color, geometrical forms, and even images of familiar scenes.

A large proportion of these last three lobes—parietal, temporal, and occipital—is relatively inexcitable to electrical stimulation. Since, therefore, little definite function can be assigned to them, they are sometimes termed “silent areas.” Evidence indicates that these regions deal with complex functions in a single sense, or correlation between two or more senses. For example, in the area where the parietal and the occipital lobes meet, lesions may give rise to either visual agnosia or astereognosis. In visual agnosia the person has difficulty in recognizing the meaning and identity of familiar objects by the sense of sight. In astereognosis there is inability to identify three-dimensional objects by cues derived from active finger exploration, even though touch sensations remain. Occasionally a patient suffering from a lesion in this area experiences a disruption of complicated correlations between visual and body sense perceptions. He is unable to form a mental image of the spatial relationships among his body parts, even though visual imagery and body sense imagery are separately retained.

8. Cerebral Localization

The layman often conceives of the brain as having extremely strict and exact localization; in short, that any given muscle is innervated by one nerve fiber, that each learned act and memory is located in one special region, and so on. There is a great deal of evidence that

localization of complex mental functions is far from exact. Lashley [3] has performed a long series of experiments with rats which have shown that the ability to learn and to remember depends more upon the amount of tissue remaining intact than upon the specific parts involved. He found a high degree of correlation between amount of cortex removed and loss, as measured in maze learning. No center for learning or for memory could be discovered. Destruction of equal magnitude in any one of the four lobes produced similar losses, if primary sensory and motor areas were left intact.

Such evidence led Lashley to a theory of equipotentiality, which presumes that neither intellectual abilities nor learned habits have definite residing places, but rather that they are mediated by the entire brain surface. This theory holds that the mass of tissue available determines quality of performance.

Verification of this theory depends upon the species and the particular function under consideration. Lashley's results were at first accepted without qualification, and applied to all species. But recent operative work upon monkeys and clinical evidence from human beings has suggested that there is greater exactness of localization as we ascend the scale. With rats, sheep, and animals without a highly developed cortex, it appears that localization of function is more generalized; hence destruction of any area will not have particularly definite effects. We have already seen, in Tables 7 to 9, that more dependence is placed upon the cerebral cortex in man and subhuman primates than in lower species.

As to particular functions, those of the motor and sensory areas are fairly closely localized. In subcortical areas, such as the medulla and midbrain, we can find the centers for various acts with a variation of no more than one millimeter. In the frog it is possible to destroy ability to breathe if one small section of medullary tissue is removed. In the motor area of man, localization of function shows a high degree of specificity. However, electrical stimulation on successive days will disclose very slight shifts, enough to prove that the same neurons need not be in use every time a certain muscle group acts. Similarly, sensory localization is not entirely specific, but it may be confined within a restricted region of a certain lobe. Simple visual acts are mediated by a small portion of the occipital lobe. Simple audition is confined to a part of one of the three convolutions of the temporal lobe.

Still more variable are associative and higher mental processes. We remember that visual memories and associations are located in the non-sensory area of the occipital lobe, and that auditory memories and associations are found in the non-sensory part of the temporal lobe.

But it is not possible to find just where certain items of information are located. For example, there is no definite spot for memories of friends' faces or of familiar tunes. Nor can accidental destruction or deliberate operation remove such specific capacities as one's knowledge of a foreign language or his mathematical ability. There is an instance of a man who received such serious war injuries that he was virtually unconscious for months and was hospitalized for over a year. He suffered some permanent loss of tissue in the frontal and temporal lobes, yet he became principal of a school; and, so far as he or anyone else could ascertain, he had lost neither general intelligence nor any specific memories.

People who have suffered destruction of cerebral tissue usually make at least partial recovery. There are several possible explanations: the lesion may partially clear up (as does congestion around a bruise or sprain); the cells which remain intact may take up the entire function; other parts of the cerebrum may function vicariously; or the act may be carried out by lower centers. It is quite probable that each of these explanations holds in certain cases. In one case a woman suffered removal of the entire right (non-dominant) hemisphere, which would include motor and premotor areas; yet she became able to walk and to perform gross movements with her affected arm. She had difficulty, but there was no total paralysis. This partial recovery may have been due to shifting to lower centers or, more likely, to attaining maximal use of residual centers in the remaining hemisphere of the cerebrum.

9. Language Disorders

(A) RELATION BETWEEN THE HEMISPHERES. We know that in right-handed people the left hemisphere is usually dominant. This hemisphere controls not only skilled acts, but intellectual functions as well. The dominance of one hemisphere, with the crossing from right to left, is more pronounced in man than in animals. The lower animals tend to be bilateral, and only monkeys and men show definite dominance. But even in man there is not a complete crossing for every function. Some motor fibers in the spinal cord do not cross, but continue down the same side into lower centers. This may explain the fact that damage confined to one side of the cerebrum does not produce *complete* paralysis.

(B) LANGUAGE AND CEREBRAL DOMINANCE. Language functions also are centered on the dominant side of the brain. Speech disorders (aphasias) are much more serious if the left side of the cerebral cortex is damaged (assuming the individual to be right-handed). In fact, it has been suggested that the non-dominant hemisphere serves mainly

to reinforce or supplement the dominant. Cases of removal of the entire right hemisphere without serious speech loss have been reported. Yet barely literate people have been reported to have lost literacy following injury to the non-dominant lobe, a fact which tends to verify the suggested theory of supplementation.

(C) **APHASIA.** Language is composed of several functions: speaking, understanding speech, writing, reading, and thinking in terms of words. Traditionally, it was supposed that each of these was located in some region of the brain, and that the type of language loss depended upon the locus of trouble. But aside from specific sensory or motor destruction this theory does not conform with the facts. [2, 4] Rarely does a person entirely lose any speech function. Even when there is serious language loss, the appropriate use of words and phrases which require no originality remains, such as "yes" and "no," exclamations, profane words, and names for common objects.

Losses may be connected with the specific area injured. A patient who suffered removal of the occipital lobe failed those problems on an intelligence test which required visual imagery; yet passed much more difficult problems where auditory or other abilities were demanded. The same patient could not name an orange when shown it, but gave the name instantly on being asked to smell it; he could not give the name for a bell, but did so when it was rung.

In some instances lower abilities have been lost while more complex functions remained. A patient may lose his knowledge of the multiplication table, but still retain sufficient ability to figure out another approach to solve his problem. An architect suffered such severe injuries that he was confined to bed and could use only two or three words; yet he whiled away his time by drawing plans for houses. Occasionally he exhibited a mistake in thought, such as a room without a door or a staircase with only eight treads (which would separate the first and second floors by only five feet), but when such errors were pointed out he never repeated them.

Aphasia is of two kinds, motor and sensory. In motor aphasia the patient has difficulty in using words properly. Slowness of speech and the telegram style of speech, mentioned above, are early symptoms. The thought may be clear, but the individual finds it impossible to utter complete, coherent sentences, especially if there is any complexity involved, as in qualifying phrases, subordinate clauses, or the more rhetorical modes of expression. The more severe the deterioration the more elementary will be the speech forms.

· Sensory aphasia represents inability to understand spoken or written language. After the first few words are heard, meaning is as absent as

from speech in a foreign language. In some people sounds lose meaning : one hears a bell, but can no longer tell whether it is the telephone, the doorbell, or a fire alarm. In speaking to such a person one must use short, simple sentences, speak slowly, and with perhaps a gap between successive remarks, just as in speaking to a young child.

The latter may sound like loss of general mental power; yet the loss is restricted to certain functions, and is not all-around. It may be more pronounced in sensory than in motor speech, in visual than in auditory capacities, or it may affect verbal abilities more than non-verbal. Patients often do better in non-verbal tests than in the more conventional type of intelligence test.

REFERENCES

1. Harlow, H. F. The neurophysiological correlates of learning and intelligence. *Psychol. Bull.*, 1936, **33**, 479-525.
2. Head, H. Aphasia and kindred disorders of speech. New York: The Macmillan Co., 1926, 2 volumes.
3. Lashley, K. S. Brain mechanisms and intelligence. Chicago: Chicago Univ. Press, 1929.
4. Weisenberg, T., & McBride, K. E. Aphasia. New York: Commonwealth Fund, 1935.

GENERAL REFERENCES

- Best, C. H., & Taylor, N. B. The physiological basis of medical practice. New York: William Wood & Co., 1937. Section VIII.
- Herrick, C. J. Introduction to neurology. Philadelphia: W. B. Saunders Co., 1924.
- Lickley, J. D. The nervous system. New York: Longmans, Green & Co., 1931.
- Villiger, E. Brain and spinal cord. Philadelphia: J. B. Lippincott Co., 1931.

V

GENERAL PRINCIPLES; VISION

I. GENERAL PRINCIPLES OF SENSATION AND PERCEPTION

1. Importance of Sensations

It is perhaps impossible to overestimate the importance of the learning process. At birth an infant has no innate knowledge or information; all the knowledge he acquires comes to him through sensory channels, principally the eye and the ear. People with normal sensory equipment take these functions so much for granted that they do not realize how serious the loss of one of them can be.

For instance, deafness produces a handicap not only in hearing but also in speaking. Deaf-mutes are usually only deaf; mutism follows because they have no way of knowing how to produce the sounds they cannot hear. Congenital deafness is usually first recognized by the fact that the deaf infant does not babble as much as one with normal hearing. His first babblings are not heard; hence do not constitute a source of enjoyment and so are not repeated.

Sensory deprivation is more serious when it has existed from birth than if it occurs during mature life, after one has had opportunity to accumulate a fund of information on which to base new acquisitions and modifications. Instructive evidence comes from individuals who have been born blind, but have gained sight by surgery. The testimony is uniform that objects are not at first identified by sight alone. It is necessary to touch an object to identify it. In this way is learned the appearance of an object which has heretofore been familiar only by touch; next time it can probably be identified by appearance alone. From numerous cases it appears that judgment of distance is entirely,

and judgment of form is partially, dependent upon learning. Even identification of shape is poor, especially if the newly sighted person does not have the advantage of contrasting colors. A red shed in front of a red house might escape notice entirely. One intelligent and well-educated man, on being given sight, was able to identify a square, a circle, and a triangle only by imagining himself tracing their outlines with his forefinger. Another person in reaching for a doorknob groped like a sighted person in the dark, thus demonstrating failure to appreciate distance. This description is given of an intelligent blind-born boy, after operation restoring sight: "The boy's behavior became disorganized; he took painted objects for real, could not distinguish shapes or estimate distances. He ran into objects more frequently than when he was blind."

It is said that the blind person conceives of the world in terms of time rather than of distance. His case may be compared with that of a passenger on a night train; he cannot see the scenery, and he knows only how long it has taken to go from one city to the next.

2. Functions of the Sense Organs

All kinds of stimuli are constantly present in nature. Our sense organs relay them for attention and disposal. The process may be compared to tuning in a radio receiver. The waves from dozens of transmitting stations are available, but a program is heard only if the set is tuned to one particular station. Similarly, each sense organ is sensitive to only one type of wave motion, and that motion is translated into physicochemical nerve currents.

There are many types of stimuli to which one or another of our receptors (sense organs such as eye and ear, or the nerve endings in the skin) is sensitive. The original energy may have been light, sound, mechanical pressure, chemical, electrical, or thermal. There are other waves, but if they are outside the receptive range of one of the sense organs they can be perceived only by the use of a scientific instrument. Examples of these are X-rays and ultra-violet rays; also the sounds produced by some insects are too high in frequency to be heard by the unaided human ear. All these forms of energy are being propagated constantly, just as radio waves hit the aerial whether or not the set is turned on; they might be said to await a suitable receiving organ. We are not interested in the ancient speculation about whether a tree falling in an isolated forest produces a sound; the point is that if a person were near he would hear the sound.

Sensations are valuable not only for acquiring information, but also for moment-by-moment adjustment. We adjust constantly to pain,

pressure, heat, cold, bright or dim light, loud or faint sounds. Sensory disorders may produce what are apparently motor defects. Locomotor ataxia is characterized by jerky, poorly controlled, and exaggerated movements of the hands and legs; in walking the patient keeps his feet wide apart and raises them unnecessarily high; and he is unable to assume a specified voluntary position. This sounds very much like a motor disorder, but actually it is sensory—resulting from destruction of sensory tracks in the spinal cord. The patient is unable to identify the position of his legs at any instant; therefore he becomes unable to regulate fine coordinating movements. Patients with disorders of pain receptors have been known to sprain an ankle severely or to suffer extreme burns because they received no cues to remove the member before the injury became aggravated.

3. We Have Many Senses, Not Just Five

Traditionally, man is supposed to have five senses; to be able to see, hear, taste, smell, and feel. But the smallest number we can possibly list is ten. Even this number includes some grouping of what actually may be different senses. The senses which are undeniably distinct are:

TABLE 10

LIST OF SENSES, WITH THEIR SUBDIVISIONS

1. Vision: color, saturation, brightness, shape.
2. Audition: pitch, localization, loudness.
3. Taste: at least four fundamental tastes.
4. Smell: at least six fundamental odors.
5. Pain: pain and tickle.
6. Touch: touch pressure, vibration.
7. Heat.
8. Cold.
9. Kinaesthetic: muscles, tendons, joints.
10. Equilibrium: semicircular canals, muscles, tendons, joints.
11. (Possibly) Organic: hunger, thirst, internal pain, nausea.

If we wished to consider each of these subdivisions as an independent sense, there would be hundreds or thousands of senses. Vision might include each perceptible color, and hearing each perceptible pitch. There is some justification for this, as we shall see from evidence on color-blindness and tonal islands. This may be stretching the point too far, but we can safely say that there are many more than the traditional five senses.

The receptors are sometimes divided into those of distance and contact. Vision and audition have their stimuli arising at a distance; touch and taste demand contact. Olfaction and temperature are inter-

mediate; their stimuli are a certain distance away, yet sensation only follows contact. A bouquet of roses under a glass jar can be seen, but not smelled. A fireplace blazing within a house can be seen, but the window bars the heat.

Although the senses are distinct anatomically and nervously, functionally there is a good deal of relationship among them. Vision and audition commonly supplement each other. Localization of sounds uses both these sensory channels. Even if we are not capable of lip-reading, we can understand a speech in a noisy room much better if we look at the speaker's face than if we look elsewhere and try to hear his words. Many spelling errors can be traced to confusion between audition and vision. Writing "their" for "there" and "to" for "too" are frequent examples from hurriedly written examinations. The pronunciation is the same, but the wrong word has been chosen. Other sensory interrelations are seen in daily life. The carpenter not only looks to see if he has planed a surface smooth, but he feels it as a more delicate check. Many of the relations between taste and smell will be discussed in more detail in Chapter VI.

4. Sensation and Perception

The process of perception is necessary so that messages may be carried from the outside world to the nervous system. But if adaptive behavior is to occur, one must understand and interpret these messages and warnings. *Sensation* is merely the objective and physiological response of the sense organ, without analysis or interpretation. *Perception* involves the first stage of awareness and interpretation. Thus, if a conversation is ignored by an absent-minded friend, the latter had a sensation but experienced no perception. When we read we have both sensation and perception. A page printed in Chinese arouses only pure sensation in most of us, but a literate Chinese experiences perception.

Perception is present in almost every sensory experience. We encounter pure sensation only in such rare instances as looking at a page in foreign characters, hearing a strange language spoken, or smelling an unfamiliar flower. Possibly the visual experience of the person who has just received his vision through an operation is closest to pure sensation.

If we look at the sentence, "I read a ream of real paper," most of us do not recognize readily the fact that four of these words have three letters in common and that three of these words are, from the standpoint of pure physical stimulation, 75 per cent similar. The perceived meanings of these three words are so far different that the overlapping is not appreciated.

Finally, it can be said that improvement (learning) in pure discrimination is scanty. The blind person who learns to read Braille and to hear more acutely than a sighted individual has improved his *use* of those senses rather than their basic capacity. Learning is chiefly perception: reading, identifying odors, liking new foods, recognizing melodies, are all acts of perception.

5. Attention

Attention is a process which clarifies sensations, memories, or thoughts. A slight scratching at the door is heard; we listen more attentively and identify it as the dog wishing to be let in. When a sound is heard outside the bedroom window, we may hesitate a moment to decide whether it is leaves rustling or rain falling. Attention is a mental flashlight; whatever it is focused upon is made more distinct.

(A) CHARACTERISTICS OF ATTENTION. (1) *It is selective.* We are told that a telegraph operator can sleep through the dots and dashes calling other operators, but wakes instantly if his own signal is called. A person may not even consciously hear dozens of automobiles passing his house, but if his family's car drives up, he will go instantly to the door.

(2) *One can pay attention to only one thing at a time.* It is often erroneously reported that certain famous men have such brilliant minds that they can pay attention to several things at once. Julius Caesar is said to have dictated several letters at a time, giving alternate sentences to each of several secretaries, in order to save time in transcription. What Caesar actually did was to alternate his attention rapidly from one letter to the other. Chess masters who play many games simultaneously do the same thing; they study one board, then another. If a person appears to be performing two activities simultaneously, one of them must be automatic, not requiring continuous attention. Someone once suggested that a good example was that of women knitting and talking at the same time; a friend thereupon asked him which process he considered automatic. We think as well while walking as while seated; but if the sidewalk is slippery, we must concentrate upon an activity which has heretofore demanded no conscious attention.

(3) *Attention wavers.* Introspective evidence demonstrates that one cannot concentrate for more than a few seconds at a time. Concentration, then, is a matter of bringing back one's attention as soon as it starts to wander, instead of allowing it to be claimed by miscellaneous distractions. Wavering of attention is said to be responsible for many accidents. The driver or worker has a momentary lapse of attention at a

critical moment. In an important football game the winning touchdown was made on a forward pass to an end who was obviously at least two yards offside. Everyone in the stadium wondered how the linesman, standing parallel to the line of scrimmage, could possibly have missed the flagrant offense. A likely explanation is that the official's attention chanced to waver just at that instant.

(B) **FACTORS PRODUCING ATTENTION.** An advertiser or a soapbox orator wishes to attract attention. A serious student wishes to avoid distractions, at least during the time set aside for study. There are at least half a dozen attention-producing factors.

(1) *Motion.* An object appearing, disappearing, or moving will draw the attention. Flashing signs over stores attract customers who fail to see stationary advertising. Sitting motionless in a large room a person may escape notice, but if he moves slightly he will be seen easily.

(2) *Repetition.* A light knock on the door may not be heard, but if repeated it will arouse the attention. Bad habits, extremely annoying if repeated, are hardly noticed the first few times.

(3) *Size or magnitude.* A large billboard or a loud sound will enjoy an advantage in competition for attention over the smaller sign or fainter sound.

(4) *Vividness and novelty.* A person with a flashy necktie stands out in a crowd of strangers. A new picture on the wall attracts attention; the familiar ones are ignored.

(5) *Interest.* The automobile enthusiast notices the details of a new model; his friend riding with him notices no more than that they passed another car. A man may pay little attention while closing prices of dozens of stocks are being reported over the radio, but when one he owns is mentioned his attention is immediately attracted.

(6) *The intensity of the stimulus must be above the threshold.* The threshold, sometimes called "limen" (the Latin equivalent and the more technical term), is the point where the strength of the stimulus is just enough to arouse a conscious response. Thus, if one can barely hear a watch ticking when it is twelve feet away or barely detect one drop of lemon juice in a quart of water, we say that we have found threshold values for the strength of such stimuli in those particular senses. The *differential threshold* is the amount of change necessary to be perceived. The speed of this change is a critical matter in determining how great a shift will be necessary to become perceptible. This is true of every sense: intensity of light, sound volume, pressure, and taste, as well as temperature. We all know that if the temperature goes up slowly it may become quite hot before we notice the change, but if

we walk from a cool room directly into an overheated one the difference is readily apparent.

(C) ADAPTATION. We soon get used to, or adapt to, a constant stimulus. The ticking of a clock soon ceases to be noticed. A bath which seems painfully hot at first soon seems lukewarm. If one changes his shoes in the middle of the day, his feet immediately feel differently, but he soon becomes adapted and forgets the newness of the sensation.

Adaptation has definite value. A rather unpleasant smell in a room will be distressing on first entering, but after a minute or two the unpleasantness will pass away. One has received his warning, which may be of survival value in the case of noxious gases, but if he must remain in the presence of the smell, as in working in a chemical plant, it is much more pleasant if his olfactory sense can become fatigued. As has been discovered experimentally, pressure and taste adapt out most quickly (around ten seconds for a stimulus of near threshold value), vision and smell take about a minute, and hearing takes several minutes.

6. What Is the Stimulus?

Previous to the present discussion of sensations, there has been no need of an exact definition of the "stimulus." Usually the term is used in the same general sense as the physicist uses "cause," as being the initiator of activity. But let us point out the various possibilities of the stimulus.

In general, the stimulus may be said to involve *change*. This change may be: (1) Presentation to the sense organ, such as a pistol shot starting a race or the telephone ringing. (2) Removal of a source of energy, such as the light going out, the clock stopping, or a blanket being lifted from a sleeping person. (3) Change in the nature of the stimulus. Since the latter occurs most frequently, we shall give several examples. A revolving airplane beacon has far greater stimulus value than a stationary light of equal candlepower. If a warning or danger sign in a factory is not changed in character or moved in location from time to time, it becomes a part of the familiar surroundings and no longer serves as an effective stimulus. We get tired of a certain brand of cigarettes or pipe tobacco; a new brand furnishes a new stimulus.

Emotional stimuli also need occasional changes in order to sustain enjoyment. Pleasure derived from a popular melody waxes and wanes. It is first heard occasionally, then a dozen times a day, and finally it becomes so tiresome that people have been known to bribe orchestra leaders *not* to play a certain piece. The public becomes tired of the same movie stars, and demands new faces.

7. Important Points in This Section

1. The sense organs are the avenues of approach for stimuli from the outside world. All our knowledge and all our information must come through one or another of the sensory channels. Deprivation of one or more senses reduces our efficiency of adjustment to our environment.

2. We have many senses, not merely the traditional five.

3. We must distinguish between sensation and perception. Sensation includes only the stimuli as they meet the sense organs. Perception adds meaning and is the first step in interpretation.

4. Attention renders perceptions clearer. One can pay attention to only one thing at a time, and to that for only a few seconds before attention begins to waver. Attention is claimed by stimuli which are moving, repeated, large, novel, or along lines of one's interests.

5. A stimulus is defined as a change in energy, which may be in the form of a sensory presentation, cessation of external stimulation, or a change in its intensity or nature. This aspect of change is also characteristic of emotions.

II. VISION

1. Structure of the Eye

In this book we are not especially concerned with the intricate details of the structure and function of the eye. However, in order to understand how the eye functions while we look, read, watch the movies, or attempt to judge distance, we must learn a few of the more important mechanisms.

The eye is much like a camera in its operation. In both cases there is an aperture which lets in the light, regulates its intensity, focuses it, and records it. The parallels may be traced from Fig. 19 and the accompanying description. Unfortunately, however, the construction of our eyes is not so exact as that of a good camera. Von Helmholtz, the famous German physicist and psychologist, is said to have remarked that if one of his workmen built a microscope as poor as the average human eye he would discharge him. Many students and professional people wear glasses to reduce reading fatigue. Glasses allow clear focus with the lens of the eye in a resting state.

One or two of these parts demand further explanation. (1) The retina contains two sensitive elements: *rods and cones*, so named because of their shapes. The rods are responsible for form vision; the cones are sensitive to colors (as well as to form). At night one sees

A. *Cornea*: tough protective coat; bends incoming light rays toward a focus.

B. *Aqueous humor*: watery fluid through which light rays pass.

C. *Iris*: colored portion of eye, usually blue or brown, which expands or contracts to admit more or less light according to the intensity.

D. *Pupil*: black spot in center of eye; large when light is dim, and shrinks to a pin point in dazzling glare.

E. *Lens*: movable focusing agent. It is flattened for distance vision, and relaxed and allowed to bulge for focusing on near-by object.

F. *Vitreous humor*: gelatin-like substance through which light rays pass between lens and retina.

G. *Retina*: contains sensitive elements, which receive light rays and translate them into nerve currents. Similar in function to the camera film.

H. *Fovea*: slight indentation, point of clearest vision. If one fixates on an object, the image of that object is projected on to the fovea. Everything else is less sharp and clear.

I. *Optic nerve*: nerve fibers originate in the retina and lead to the various visual centers. Occipital lobe for more complex and conscious, thalamus and other lower centers for more reflex and automatic, processes.

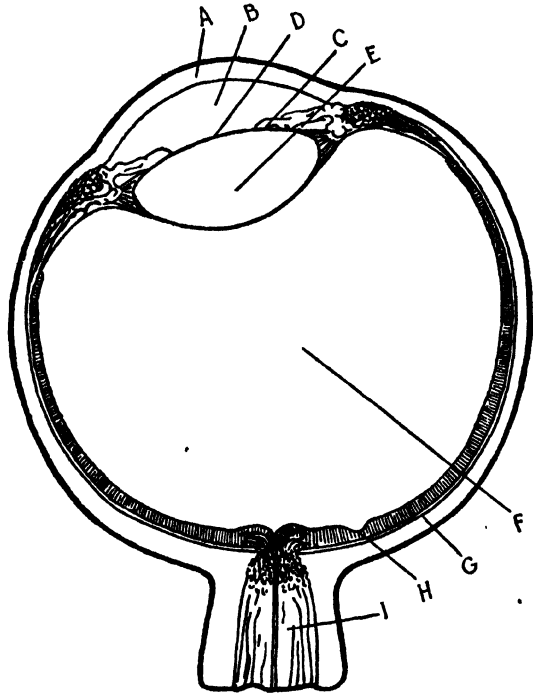

FIG. 19.—Cross Section of Human Right Eye.

with the rods alone. (2) Dark adaptation occurs not only through the iris, but also in the retina. It may take as long as twenty minutes before one is completely dark-adapted. When we enter a dark movie theater we stumble over people and seats, but after ten to twenty minutes we can recognize friends' faces several rows away.

(3) Where the optic nerve goes through the retina, practically all the rods and cones are crowded out, producing the *blind spot*. In daily life you may not realize that a portion of each visual field is missing, because you have two eyes. But if you place your head about eight inches above the page, look at the x on the diagram opposite, shut first one eye and then the other, and pay attention to the numbers as you move a pencil outward, you will see the tip of the pencil disappear and

then reappear. In this crude way you can ascertain the area which the optic nerve covers.

7 6 5 4 3 2 1 x 1 2 3 4 5 6 7

A short distance behind the eyes, the two optic nerves come together in the form of an X. Half the fibers cross, while the other half bend back and remain on the same side. Hence a rather peculiar result occurs if the optic tract is interrupted on one side behind the point of junction: one loses vision toward one entire side, and can see only what is to the right, or to the left, of his nose. But if the disorder is just behind the eyeball, before the chiasma, the vision of one eye will be entirely lost, and that of the other will be unimpaired.

The visual pathways through the brain are too complex to trace in their entirety. We have already traced some of the principal tracts in Chapter IV. Suffice it to say that the more automatic and reflex functions are mediated through the superior colliculi in the lower brain centers, while the conscious, associative, and discriminative processes employ the occipital lobe.

2. Disorders of Vision

(A) WHY DO WE NEED GLASSES? There are three fairly common defects: nearsightedness (myopia), farsightedness (hyperopia), and astigmatism. Fig. 20 portrays the first two of these conditions. In normal vision the cornea and lens bring the incoming rays to a clear focus just at the retina. In nearsightedness the cornea may have too much of a bulge or the lens may be too rounded; the result is that the focus is effected before the rays hit the retina. They start to spread out again, and the image is slightly blurred, as when one neglects to adjust a camera for the proper distance. In farsightedness the point of focus is behind the retina, so here again the image is blurred. Astigmatism is caused by imperfect curvature of either the cornea or the lens, which produces a distorted image.

This description assumes that the eye is in a resting condition. Most young people have defects so slight that the various eye muscles compensate for them. This correction, however, is achieved only at the expense of extra energy and fatigue. With students and professional men, who have to do a great deal of reading, minor visual defects demand correction. It is wise to let the glasses perform the task of adjusting and to avoid overworking the eye muscles. Well-fitted glasses enable one to read with the eyes in a normal resting state.

As a person passes middle age, normal physiological changes slightly

flatten the lens, so that one tends in effect to become farsighted. Some previously nearsighted people can discard their glasses. Those who are already farsighted may need stronger lenses.

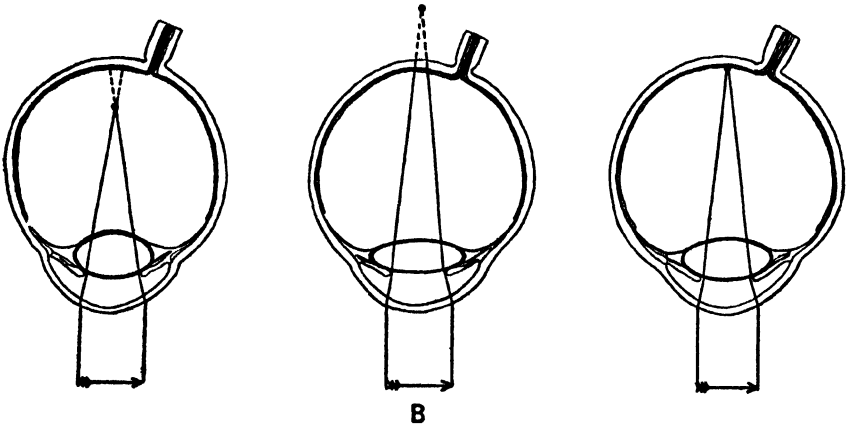

FIG. 20.—Typical Optical Defects.

Here one can see the causes of the most common visual deficiencies, and the reasons why many of us need to wear glasses. In A the cornea and the lens are well rounded and balanced, so the individual has perfect vision. In B we see the cause of farsightedness; the cornea is too flat or the lens is too little rounded, or both. The light rays do not come to a focus before they are intercepted by the retina. C shows nearsightedness. The cornea and/or the lens are too rounded, and the focusing occurs before the rays hit the retina, so they begin to spread out again. In most young people defects which are not too serious can be compensated, but only at the expense of eye-strain. Hence we wear glasses so that we can artificially arrive at the status of the individual with perfect vision. That is, the rays arrive at a focus just at the retina, with the eyes in a resting condition.

(B) CAUSES OF BLINDNESS. Since the complete visual act must involve conduction from the cornea through to the occipital lobe, blindness may result from interruption at any point. If the cornea is badly scarred, say from a burn or an explosion, it is no longer transparent. If the lens solidifies, as in cataract, the light rays are interrupted. Retinal inflammation or detachment produces blurred vision. This latter disorder is a frequent cause of blindness in veteran boxers; frequent blows dislodge the retina, and it floats in the vitreous humor. Blows may also injure the optic nerve. Interruption of the visual nerve tracts by tumor, accident, or atrophy may result in total blindness, blindness of one eye, or loss of vision in certain areas, depending upon the locus of disorder. If there is a lesion in the cortical area, there may be loss of ability to read, to identify familiar objects, or to judge distance. In some such cases the patient theoretically can still see, but he has lost ability to use vision meaningfully.

(C) MINOR VISUAL DISORDERS. *Night blindness* is a condition in which a person is for all practical purposes blind at night. Owing probably to a defect in the rods, for which lack of vitamin A in the diet is partially or totally responsible, he cannot adjust to reduced illumination. *Glare blindness* is likewise a disorder of adaptation, in which the individual cannot adapt to sudden illumination, such as the headlights of an oncoming car. A person so affected may have to stop his car dead every time he meets another or he will have to cease driving after dark. It is possible to reduce the effects of glare by watching the right side of the road. Dimming headlights is not only an act of courtesy, but it may prevent one from being hit by a driver who has glare blindness. *Lack of coordination of the two eyes*. Normally the two eyes have virtually the same visual fields. If the eye muscles are out of balance, and one eye turns inward or outward, the two fields will be disparate. One image must then be ignored. In such cases one develops what is termed "psychical blindness," which means that the eye is not organically defective but that what hits one retina is given no attention. Since several years of disuse may result in genuine blindness, it is important to have muscular imbalance corrected at as early an age as possible.

3. Eye Movements

(A) VISION OCCURS ONLY WHEN THE EYE AND THE OBJECT ARE STATIONARY IN RELATION TO EACH OTHER. Just as with photography, for sensation to occur there must be exposure for a certain length of time. In reading, the eye does not move smoothly along the line; it must pause to allow visual impressions to build themselves up. In following a moving object the eye must pursue it, as a hunter follows a bird before firing. If the eye were held still, the moving object would produce merely a blur on the retina. This fact is responsible for the peculiar back-and-forth movement of the necks of chickens as they walk. Since their eyes are far on the side of their heads they see with only one eye at a time. The bird must pull his head backward with alternate leg movements, to keep his eye stationary in relation to the environment. Presumably he sees little as the head returns forward.

(B) EYE MOVEMENTS IN READING. The eyes progress along a line of printed matter in jerks, taking in two or three words at a time. In a typical line the average reader uses about six movements. A greater number are taken by children, by adults of lesser intellectual capacity, and in reading technical passages.

Fig. 21 shows several figures from a study by Tinker [9] of eye

movements used under various reading situations. The vertical lines indicate each position at which the eyes stopped momentarily. The figure at the top shows the serial order of the movement, and that at the bottom gives the duration of fixation in hundredths of a second.

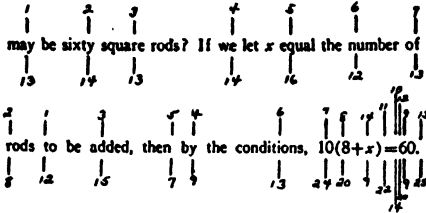

Normal reading by a college student. We see fairly regular and progressive reading, with few regressive movements, and not very wide variations in time spent on each fixation.

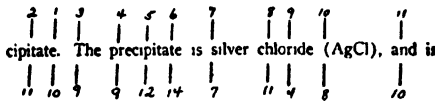

High school student reading elementary scientific material. Regularly spaced saccadic movements, with one regressive. Student obviously failed to read the formula, which gives a suggestion that if such formulae are to be learned the name of the compound should not also be presented.

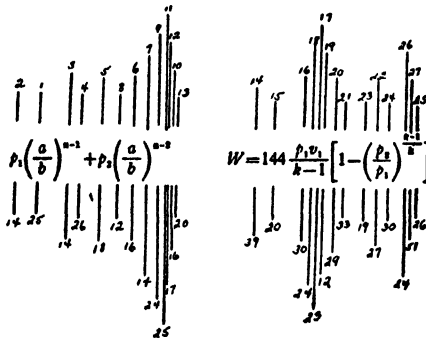

College student reading mathematical formulae. Illustrating the extreme complexity of eye movements necessary to read a complex mathematical formula. The durations of fixations are much longer than in reading prose.

FIG. 21.—Eye-Movement Fixations in Reading.

The lines indicate the successive points of fixation, the numbers above showing the rank order (1, 2, 3, etc.) and the lower numbers the durations of fixation in fiftieths of a second. Thus, the first fixation came at the "y" in "may" and lasted 13/50 of one second. (From Tinker.)

(C) EFFICIENT READING. From the three charts we discover several common faults in reading habits: (1) Too many fixations per line are used, which slows up speed of reading. (2) A reader may not fixate on the proper place when beginning a line, which necessitates a wasteful regressive movement. (3) A reader may skip over important material.

Efficient reading is especially important in literature courses in which there may be assignments of several hundred pages of reading each

week. The student who must take several hours more than his classmates to cover the same assignment is proportionately handicapped. Studies of eye movements of students on probation have shown that many of them are inefficient readers. One should cultivate forward reading and try to reduce the number of fixations per line.

Much of the eye fatigue from protracted reading is said to be due to the long sweep from the end of a line to the beginning of the next. It is suggested that books should follow the example set by newspapers and popular magazines—be set up in the form of several parallel columns. The wider the page the more desirable this is. It would be much less feasible to alternate the order of lines, as in this illustration:

It is easy enough to read in a progressive direction,
 .enil siht ni sdrawkcb krow ot redrah hcum tub

There is no physical reason why we cannot read from right to left. Arabic writing proceeds this way. But from a practical standpoint it is doubtful if such a suggestion would enjoy popularity.

Can one skim? At least two physiological facts militate against hasty skimming. First, only material centered near the fovea is clearly seen. Second, the eye must pause to assimilate. One cannot skim, literally. If one does not wish to read every single word, he must still read some of the phrases or sentences. Stories of famous men who read whole pages at single glances are absolutely false. High speed may be attained by a reader who is familiar with the material. For example, if he has been reading a large number of articles on a controversial question, say communism versus capitalism, he learns all the principal arguments from the first few articles, and covers the remainder mainly to discover each particular author's viewpoint. It is not good judgment to skim in a new field, such as a first course in psychology, sociology, or economics. It may be fatal in mathematics or physiology, where details are important.

(D) TYPES OF EYE MOVEMENTS. So far we have concerned ourselves only with the jerky movements used in reading. These are technically known as *saccadic*. They are used when one looks from one object to another, as in reading, exploring scenery, or searching for a friend in a crowd. A second principal movement is the *pursuit*, which is best exemplified by holding one's head stationary and following a moving object with the eyes. Here the eyes must move to ensure vision, but the field is kept focused on a constant spot of the retina and the image can build itself up. A third type is the *compensatory*. A person tries on a new hat, turns his head from side to side to study the hat from different angles, but keeps his eyes fixated on the hat. In this

case the eyes remain stationary in absolute space, but they move in the sense that their position within the head changes. In a fourth class of movements, *convergence and divergence*, the two eyes “toe in” or “toe out” to focus on an object which is approaching or receding.

These movements do not occur in isolation. In many visual acts all four types are involved. Suppose one is held up at a railroad crossing, and amuses himself by reading the symbols on the sides of the freight cars. Perhaps most important are the pursuit movements, employed as one follows each car. But one also uses saccadics in reading the legends, especially if they are fairly lengthy. One also moves his head, thus bringing in compensatory movements. Finally, since each car approaches and recedes, divergent and convergent movements are employed.

4. Visual Illusions

We have defined perception as sensation plus meaning or interpretation. Sometimes this interpretation is faulty, and one is deceived. Psychologists are familiar with the proofreader’s illusion: expecting words to be spelled correctly, the reader fills in missing letters and mentally corrects misspellings. Did you notice the word deliberately misspelled in the preceding sentence? This proofreader’s illusion is so strong that hardly a book is published without several such errors, even though author and editorial staff read galley proof and page proof word for word several times.

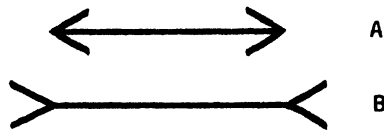

FIG. 22.—Müller-Lyer Illusion.

Which of the two straight lines is longer? How much is your judgment influenced by the directions of the arrows and the apparent enclosed areas?

Many illusions are based upon drawing attention to some irrelevant element. In the Müller-Lyer illusion judgment is based not on actual length of the lines, but in terms of the area enclosed. In the staircase illusion difficulty arises because there is no background upon which to base judgment. If a background were drawn in, there would be no shifting from apparently under to apparently above the stairs. Shapes of containers affect snap judgment as to cubic contents. A tall slender can appears to contain more than a squat one of equal capacity. A bottle seems to contain more than a tin can, because it is difficult to discount the thickness of the container walls.

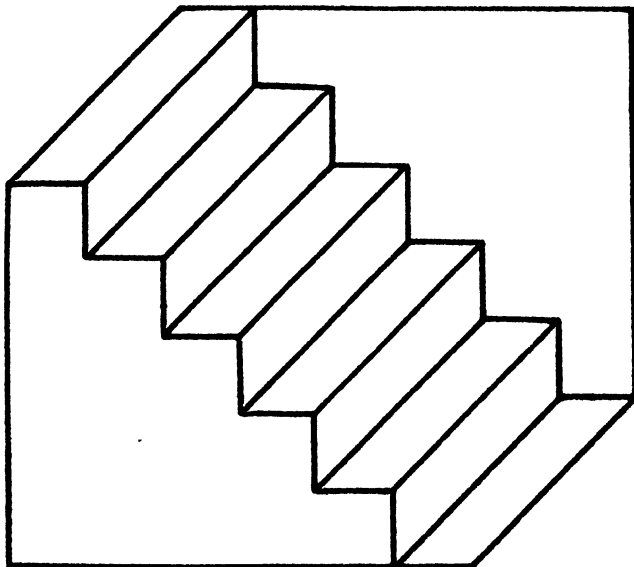

FIG. 23.—Staircase Illusion.

Are you underneath looking upward, or looking downward from above? Keep studying it, and see it shift back and forth. Which image persists longer?

Some illusions depend upon drawing the eyes of the spectator away from the critical point. Jugglers often make violent motions with the left hand to draw the onlookers' attention away from what they are doing with the right. Fake plays in football have the same purpose. A fullback pretends to hand the ball to another, but keeps it himself, hoping that the opposing team will ignore him and pursue the fullback. A play is often so cleverly executed that spectators with a good view of the field watch the wrong man and miss the play entirely. In one case a radio announcer, veteran of ten years' broadcasting experience, announced that a kick had been made; then he had to retract and tell about the fake kick and subsequent end run. It is interesting to note that children and adults of lesser intelligence are less likely to be deceived than brighter adults, since they have less idea of what to expect and are not so easily distracted.

Just as the magician deceives an audience by directing attention away from the center of action, so illusions can be utilized in costume design to direct attention away from an unfavorable characteristic. If a woman feels that she is too tall, too short, has too wide hips, or too wide or too narrow shoulders, she can minimize such departures from the average by practical application of certain principles of visual perception. Naturally, more people try to minimize size than to enlarge it,

but the principles are approximately the same. Women are inclined to be more interested in these things than are men, and their clothing permits of greater effects.

In general, minimizing a dimension demands lines directing the eye in the opposite direction. Attention may be deflected from one's poor points by placing decorations in such a way as to draw attention to some more favorable quality. We shall illustrate the practical use of certain principles by discussing the treatment of several typical body builds. [4]

(1) *Tall, thin people* should use horizontal lines, and avoid the vertical. Women are able to effect a break by means of a two-piece dress, a tunic, or a wide girdle. A round or square collar will broaden the shoulders, but a V-neck will accentuate height. A necklace should be of the choker type, not long. A broken sleeve will cut the length of the long thin arm. For men, broad shoulders, wide lapels, belted coats, and patch pockets will create an illusion of breadth, and consequently of lesser height. A dark coat and light trousers will break the line. Coat must be kept buttoned and bow ties avoided, or the expanse of shirt front will defeat the purpose.

(2) *Short, thin people* should choose clothes with vertical or diagonal lines. A hat with a turned-up brim will draw the looker's eye



FIG. 24.—Applications of Principles of Illusion to Dress.

The design of clothing can do much to affect apparent size. The pair of pictures on the left illustrates girls of the same short, stocky build, but one wears stripes to call attention away from width and toward height while the other wears checks and puff sleeves. With the girl who is taller and thinner, shown in the two sketches at the right, just the opposite principles hold.

upward. Striped or bright print materials appear to add bulk, because the space is more completely occupied than in plain fabrics. A bolero will broaden the shoulders, make the bust seem fuller and the legs longer. A string of beads of medium length also will call attention to the vertical dimension; but if too long, will make the woman look like a little girl in her mother's clothes. Men who are short and slender may wear suits of shaggy checked or plaid material. Vertical stripes add height, but are likely to create too much of a slender effect.

(3) *Stout persons* should wear vertical lines to emphasize height and minimize width. Many large women are tempted to wear tight clothing, probably in order to be able to say that they wear a small size. An overflowing effect usually results; tight clothing may be used to accentuate virtues, not to smooth out bulges. A slightly loose dress will help to conceal large dimensions. Plain colors will appear smart and trim. Stockily built women should avoid puff sleeves, wide collars, large hats, and striking colors. Men of large size should choose stripes and smooth materials. They should avoid checks and shaggy fabrics.

(4) *Special defects* can be minimized by following the general principle of deflecting attention from shortcomings and toward the best points. Fullness over thin parts and more severe lines over broader parts will serve to restore an irregular build to average dimensions. Women have the advantage of being able to effect some adjustments precluded by the more standardized design of men's clothing. The waistline can be moved up or down to adjust to long or short legs, or to a long or short trunk. Certain limits are, of course, set by styles of the particular season.

Clothing can be designed also to serve what was perhaps its original purpose—concealment. Transparent or thin clinging material should be used only to bring out good points. What one desires not to be noticed must be concealed. For example women who have heavy upper arms should not wear sleeveless dresses or attempt sleeves of transparent material or of openwork design. The most favorable effect will be produced by a sleeve of straight, undecorated, dark material.

Other items of dress should be selected with bodily proportions in mind. The hat brim should be of about the same width as the face: the narrow face demands a narrow brim. A wide brim makes the face appear doubly narrow; a narrow brim on a round face looks silly. A woman with a prominent nose should not wear a hat with receding lines; that gives double emphasis to a single prominent dimension. Only medium or tall people can wear shaggy fur coats. A short, stocky girl with a raccoon coat somewhat resembles an animated Teddy bear; she should wear a coat of some short-haired fur.

5. Judgment of Distance

(A) **JUDGMENT OF DISTANCE IS LARGELY LEARNED.** For several hundred years there raged a philosophical dispute as to whether judgment of distance was innate or acquired from experience. It is difficult to establish definite proof on either side, since growth and maturation are intertwined with learning in the growing child. By the time the normal child is old enough to have acquired speech and good muscular coordination so much of both has been acquired that it is difficult to evaluate evidence. Therefore we must draw evidence from abnormal cases. Persons born blind whose sight is given to them when grown seem to have virtually no conception of distance in their first visual experiences. Very young children often make large errors. A two-year-old German boy asked his mother to reach the balloon for him; actually it was a huge Zeppelin sailing a mile high in the sky.

Below are listed various cues which assist us in judging the distance of objects. [1] Some of these are perceptible with a single eye; others demand both eyes.

(B) **MONOCULAR FACTORS IN JUDGING DISTANCE.** If a person shuts one eye, or has a defective eye, he can judge distance by any of the following cues:

(1) *Relative size.* Other things being equal, the smaller of two images is judged to be farther. This is supplemented by knowledge of the actual size of the two objects. A small shed in front of a barn and a child nearer than an adult produce smaller images, yet are judged correctly.

(2) *Relative distinctness.* Since the air is not perfectly transparent, distant objects are less sharp in outline and detail than nearer ones. Painters use this principle in producing the illusion of depth on a flat canvas. Faithfulness to background detail would negate the desired impression. On clear days distant objects appear falsely near, because they are seen in extraordinary detail.

(3) *Vertical position.* The higher in our visual field an object is, the closer it actually is to the horizon, and the farther away we judge it to be. This is subject to some error in the case of intervening objects, such as trees and buildings, but it applies especially to objects of roughly equal distance, such as mountains in a range.

(4) *Overlapping.* If one sees all of one house, and only part of a second, he rightly judges that the first is nearer. In a painting a fence disappears behind a tree trunk and then reappears on the other side; by this we know that the tree is between us and the fence.

(5) *Presence of intervening objects.* Golfers know that it is very

difficult to judge distance from the green when the fairway is entirely level and there are no trees near by. It is virtually impossible to tell how far away a certain hummock may be when there is fresh snow on the ground, but after the snow has been cut up by foot or ski tracks, it is much easier. It is difficult to estimate the distance of a mountain range when one is standing on a mountain and a deep valley lies between.

(6) *Color shifts.* Compare the colors of a distant mountain range with those of the nearest hillside. The predominant colors in the distance are purples and hazy blues; those of nearer objects may contain reds, greens, and yellows. This is another factor utilized practically by painters to give the impression of distance.

(7) *Relative speed of motion.* If one sees cars or a train moving in the distance, he can form some idea of approximate distance. If they seem to be barely creeping along, he knows that they are far away; if they are progressing at a fair rate of speed, he judges that they are quite near. This factor is of special importance when one does not know the exact size of the moving object. A huge airplane five miles away will be no larger than a small one only two miles distant; yet the first will seem to be moving slower.

(C) BINOCULAR FACTORS IN JUDGING DISTANCE. The seven methods of judgment mentioned above can all be used by a one-eyed person. But his accuracy is not so good as that of the person with good vision in both eyes. There are two principal ways in which the two eyes work together.

(1) *Stereoscopic vision.* A generation ago a favorite parlor amusement was to look at pictures through a stereoscope. Impressions of depth are created by taking overlapping pictures with two cameras, with the two lenses at approximately as far apart as are the two eyes. Then the stereopticon projects slightly different pictures into the two retinæ. If quite different angles of an object are seen, there appears to be greater solidity and nearness, but if the areas virtually overlap one judges that the object is farther away.

(2) *Kinesthetic sensations.* Since the eyes have to turn inward to focus on a very close object, the relative sensations of strain in the eye muscles give clues as to distance. Since at approximately fifty feet the two eyes point nearly parallel, this sensation of strain is of assistance only for relatively close objects.

It also appears that binocular vision is extremely valuable in estimating the position in space of a moving object. Try driving a car or catching a baseball with one eye shut, and the difficulty will become evident immediately. If you try either of these experiments, be ready to open the other eye before an accident results!

(D) **COMPARISON WITH KNOWN DISTANCES.** The various factors here discussed are supplemented by comparison with known distances. A golfer playing on a strange course will make comparisons with holes on his home course, and select the appropriate club to hit the ball the estimated distance. Or he will note that a certain distance is a little longer than the length of a football field (100 yards), or that a strange lake must be about a mile wide, because the opposite shore appears about the same as that of a lake with which he is familiar.

6. Color Vision

(A) **PHYSICAL BASIS OF COLORS.** Light comes to us in the form of waves, possibly somewhat like the waves on a body of water. These light waves are very minute; their crests, for yellow light as one example, are only about a fifty-thousandth of an inch apart, as compared with crests several feet apart in water. Red rays, at one end of the spectrum, have greater crest separations, while blue or violet waves arrive at the eye with greater rapidity; that is, their vibration frequency is greater.

(B) **COMPLEMENTARY COLORS AND COLOR MIXTURES.** For every hue there exists another hue, known as its complementary color, which tends to cancel the first. In the primary colors, we have three main pairs:

Red	—	Green
Blue	—	Yellow
Black	—	White

(There is some argument whether black is a color. For the sake of our present discussion, we may temporarily assume it to be such.) If one rotates a disk composed of proper proportions of each member of any of these pairs, the result will be a neutral gray. If a slight trace of either color remains, its proportion may be reduced until the desired gray is effected.

Hues which are not complementaries sometimes will mix to produce a new hue which may or may not appear at all similar to either of the original two. Yellow and green will form an intermediate yellowish-green. Green and blue produce a color halfway between, an ambiguous shade whose predominant hue is subject to debate.

Red and yellow paint mixed together will produce orange, a qualitatively new hue. Details of color mixture are not important here. It is sufficient to say that every spectral color can be produced from blue, yellow, red, and green—and possibly we could dispense with green.

It is impossible to give any more precise details, since color mixtures

vary in their results according to the methods employed. Sectors rotating on a color wheel superimpose one wave length on another, whereas two paints produce a chemical fusion.

(C) **AFTER-IMAGES.** Because a certain brief time is necessary for an image to build up on the retina, the image does not die away instantaneously. If it has been built up for a full minute, the sensation may continue for many seconds or even several minutes after the stimulus has been removed. This continuing sensation is termed an after-image. It may be in black and white, or it may be in color. Generally one finds a hue reversal, following complementary color principles. Thus, if one looks at a black surface for a minute, the after-image will be white or grayish. A shade of red will result in sensation of that particular green which is its complement.

We give two illustrations to show black-white reversal. The after-image will best be built up by fixating on a point near the center of each picture; keep the gaze right on that point and allow the image one full minute to build up. Then look at a gray or neutral surface and in a few seconds the image will appear. If you have colored crayons or papers, you might make a small red square inside a larger green square; then repeat the same with blue and yellow.

Positive after-images occur sometimes, but are not so common. The best example is seen when one looks into the sun or a bright light; a blur of the same yellowish hue dazzles one at first, and fades away slowly.

(D) **COLOR ZONES IN THE RETINA.** We have already seen that colors are perceived through those elements in the retina which are known as the cones, while form is mediated through both cones and rods. It happens that the rods cover virtually a semicircle, but the cones do not. Only in the center of the visual area are all hues seen, blue and yellow are perceptible over a good share of the retina, but at the outer edges only black, white, and the intermediate grays are visible. [5]

It may seem strange that one has never realized these facts. A red object, however, does not vanish when its image is projected near the extremities of the retina; it is present in vision, but appears grayish.

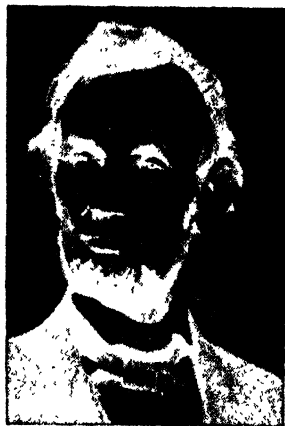

FIG. 25.—Negative of a Well-known Historical Character.

Look at him for a few seconds, and then look at a neutral surface. As soon as you have done so you will recognize the picture.

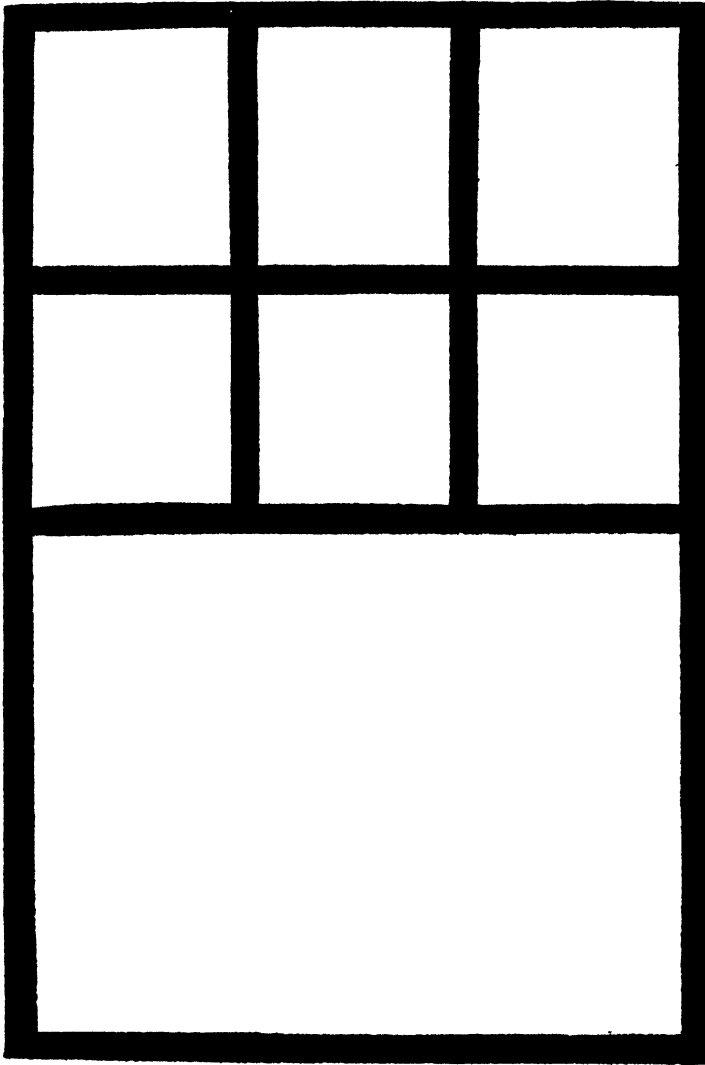

FIG. 26.—Development of an After-Image.

Imagine yourself looking out a window. Look steadily at the middle of the center cross line for about a minute, then look at a neutral (gray) surface. Several things are to be noticed: as the after-image develops, the lines will begin to swim a little; the black and white will reverse about three seconds after you look away; and the after-image will persist for as long as one to three minutes, possibly drifting away from the point of fixation.

If a dark red, it will appear nearly black; if a pinkish tinge, it will seem light gray. One may test this by fixating directly ahead and moving a colored object gradually from the point of fixation.

A practical application of this principle recently occurred in a basketball game. The losing team failed to take this factor into consideration and thereby lost the game. This team often used tricky passing, where a player would look at one teammate, but pass to another. Since this third man was seen only in peripheral vision, his jersey appeared as a shade of gray, and the ball was passed to the wrong team. This is especially liable to occur if the color is either red or green, since these are clearly seen only within a few degrees of the direct line of regard. Therefore, if a team is relying on a tricky mode of passing, it should take pains to wear jerseys of very different intensities, such as light red in contrast to dark blue, or preferably to wear a striped jersey so there can be no confusion at all. In addition, stripes are very easily seen when the wearer is in motion, thus providing additional attention value.

(E) **COLOR PREFERENCES.** Discussion of absolute color preferences is more academic than practical. Colors which appear beautiful in a sunset would be frowned upon in a shirt. Abstractly both men and women prefer red and blue over other colors, but this does not suggest that all clothes or all advertisements should be just in these two colors.

Experience is extremely important in color preferences. This includes not only personal experiences, but conformity to local and seasonal styles. In California the bright sunshine and informality of behavior predisposes to brightness in both architecture and personal adornment. Present trends favor greater liberality in color and shade combinations in both clothing and home decorations than were fashionable a decade or two ago.

7. Color Deficiencies

(A) **NATURE.** Between 5 and 10 per cent of men (but practically no women) lack perfect color discrimination. Existence of such deficiencies has been recognized for several centuries, and has traditionally been called color-blindness. Since this term contains an inaccuracy, we would prefer to call the disorder "color-weakness." The so-called color-blind person is able to see some and often all colors, but has certain quantitative deficiencies. [2, 8]

(B) **THERE ARE THREE MAIN FACTS ABOUT COLOR-WEAKNESS.**

(1) It is almost entirely confined to males.

Color deficiency is innate, and is inherited as a sex-linked trait. This means that it is passed along from a man, through his daughter, who

possesses normal color vision, to her son (his grandson). Thus it skips a generation, and is handed down by the female side of the family. Women are said to have color-weakness only if their father and their mother's father both had it.

(2) The colors most commonly affected are red and/or green; blue and yellow are seldom affected.

The totally color-blind person (the term "color-blind" is accurate only in case of absence of all color vision) would see just blacks, whites, and the intermediate grays. His visual world would be such as we see in the movies or in a photograph. But blue and yellow are rarely affected. The disorder is almost always confined to reds and greens.

(3) It usually exists in the form of weakness to one or more colors; rarely is any color entirely imperceptible.

Even red and green are rarely totally missing; rather, there is merely a weakness in discriminating certain shades of one or both. The bright, clear, saturated hues are often as well distinguished as by the normal, although possibly they appear less clear to the affected individual. But the darker shades, such as the black-red of dried blood, and lighter tints, such as pink, are more subject to confusion, either with other colors or with grays of equal intensity.

This discussion should show that color deficiency is not standardized; it occurs in infinite variations. Possibly no two persons are exactly alike in their color acuity, especially where some weakness is present. And conversely we must not assume that two persons see exactly alike just because both have partial color-blindness.

(C) WHAT DOES THE COLOR-WEAK PERSON ACTUALLY SEE? This question has been the source of much debate, but no satisfactory answer can be given. Each of us knows colors only in terms of what we actually see, and we describe our color experiences in words which we have learned. When we were youngsters our parents may have pointed to a barn, and said, "That is red." The fact that two of us agree that the barn is red does not necessarily prove that each sees exactly the same hue. A person with a slight red-weakness might still designate the barn by its correct color, but it might appear duller or otherwise different from the hue seen by a normal person. [3]

One important fact is that the affected person has no gaps in his visual field; he sees something. He may even fail to realize he has a handicap until confronted with some situation where his judgment is contrasted with another's in daily life or on a color discrimination test. One college student discovered his severe green-weakness when he happened to mention to his roommate that a certain (brown) book appeared the same as the bright green spring grass. Another first

learned of his deficiency when his mother pointed out some wild flowers which he could not see at all since the colors failed to contrast with the foliage.

(D) APPLICATIONS. In general, the color-weak person is not especially handicapped, but he will have difficulties in a few situations, and there are others where he will be better off if he recognizes his deficiency. Locomotive engineers and telephone repairmen need to have normal color discrimination. Medical students are handicapped in laboratory work if they have these deficiencies. Clothing and drygoods salesmen and florists should have good color discrimination. While few automobile accidents are caused by persons with red-green deficiency, the driver should recognize his condition so that he can learn to depend upon cues other than hue alone. Finally, the color-weak person should take care to obtain sound advice when purchasing clothes. And since his friend will not always be present to advise him in dressing, he should avoid shirts or ties of striking colors, and concentrate on more conservative shades where possible errors in choice will not be conspicuous.

REFERENCES

1. Carr, H. A. An introduction to space perception. New York: Longmans, Green & Co., 1935.
2. Haupt, I. A. Tests for color blindness. *J. gen. Psychol.*, 1930, 3, 222-267.
3. Hayes, S. P. The color sensations of the partially color-blind. *Amer. J. Psychol.*, 1911, 22, 369-407.
4. Hempstead, L. Color and line in dress. New York: Prentice-Hall, Inc., 1932.
5. Howell, W. H. Text-book of physiology. (11th ed.) Philadelphia: W. B. Saunders Co., 1930. Especially Chapter XVII.
6. Ishahara, S. Tests for color blindness. (7th ed.) Chicago: Stoelting and Co., 1936.
7. Miles, W. R., & Craig, H. Color blindness in dry goods salesmen. *Person. J.*, 1931, 9, 437-449.
8. Terman, S. W. A new classification of the red-green color blind. *Amer. J. Psychol.*, 1929, 41, 237-251.
9. Tinker, M. A. A photographic study of eye movements in reading formulae. *Genet. Psychol. Monogr.*, 1928, 3, 65-182.
10. Freeman, G. L. Relative adaptation times of the five senses. *Psychol. Monogr.*, 1936, 47, No. 212.

VI

AUDITION AND CONTACT SENSES¹

I. AUDITION

1. Auditory Stimuli

Four major phenomena of sound of special interest to the psychologist are: pitch, timbre, chords, and loudness. [8]

(A) **PITCH.** Sound comes to us in the form of air vibrations or waves. The normal human ear is capable of receiving sounds of from 16 to about 20,000 or 30,000 d.v. (double vibrations) a second. Vibration may be illustrated by holding a ruler on the edge of a desk, flipping the far end, and watching it vibrate back and forth. A double vibration is the complete cycle, from top to bottom and back again to top. In daily life the upper end of the range of pitch is seldom used. Pitches of over 2,000 d.v. rarely occur except in the shrill squeaks of insects. To give a few samples of pitch: middle C has 256 d.v.; the C an octave higher has 512; a man's speaking voice is about 150 to 200, and a woman's is generally between 300 to 350 d.v.

In melody the important thing is the relation in pitch between one note and the next. There is a constant relationship between the notes, so that one may raise or lower each note of a melody any desired amount to fit in with a singer's best range. A person who plays by ear can start a given melody with any given note, and produce the desired effect. In fact, most untrained persons fail to realize when the key is changed.

An interesting point is that different pitches have different carrying powers. Pitches from 1,000 to 2,000 d.v., which represent roughly between two and three octaves above middle C, produce the greatest

¹Much of the material customarily treated in connection with these senses is physiological and physical in nature. We shall treat only data of a more genuinely psychological nature.

volume per unit of energy. This is crudely exemplified in many situations in daily life. Announcers for open-air events are usually men with rather high-pitched voices. A famous prize-fight announcer had practically a falsetto, but his voice could carry to thousands of spectators in a noisy arena. A woman's shriek may be heard farther than a man's bellow. At the opera a soprano can drown out a bass. The sound of a single cricket may be heard above the rumble of city traffic. The next time you hear Sousa's famous "Stars and Stripes Forever" march, notice in one part how a piccolo dominates the bass horns and other low-pitched instruments.

(B) **TIMBRE.** Timbre is the means by which we differentiate one musical instrument from another or one friend's voice from another. If middle C is sung, and then played on a piano, a flute, and a violin, there would be no difficulty identifying the instrument. Less precise sounds, such as glass being broken, a knock on wood, or a silver fork dropping onto a hard substance, can also be identified

This identification is possible because of timbre. A sound is composed not only of a fundamental pitch, but also of overtones. A violin string vibrates as a whole from its two ends, and also in halves, in thirds, in quarters, and in even smaller divisions. Thus, middle C is composed not only of a sound wave having 256 d.v., but also 512, 768, 1,024, and so on. If only the fundamental (the 256 in this case) were present, we would be unable to tell a human voice from a trumpet or a violin. Discrimination among various musical instruments and various friends' voices comes not from the fundamentals, but from the relative strengths of the overtones. Filters which block out overtones make the voice harsh and nasal, so that one would not recognize his best friend's voice.

Some instruments have a relatively pure tone; that is, most of their power is concentrated in the fundamental. Others, such as the human voice, an organ, or a bell, are especially rich in overtones. For concrete comparison, let us contrast the overtones of two wind instruments, the oboe and the clarinet. The oboe has twelve or more overtones, but the fourth and fifth have the greatest strength. The clarinet has at least twenty detectable overtones, with the seventh, eighth, ninth, and tenth predominating. In fact, these four overtones account for more than half the total strength of the tone. In the G string of the violin the fourth overtone is stronger than the fundamental. [3]

Certain musical instruments convey characteristic psychological impressions. The overtones of the oboe give it a reedy quality, and hence it is an ideal solo instrument to depict pastoral scenes. War and strife are suggested by a trumpet. The violin is soothing, appropriate for

lullabies. The bassoon is often used for humorous connotation, as a clown dancing. The humor arises from deep, nasal tones played rapidly.

(C) **CHORDS.** Chords are composed of notes whose fundamentals and overtones combine in certain mathematically established relationships. If an octave is struck on a piano the notes hardly seem as two; rather, it seems almost that the same note had been struck twice. This is because the overtones are the same. A fifth, C and G, blend almost as perfectly. Discords are produced by overtones clashing with each other. Minor chords might be said to be halfway between blends and clashes. Play a sixth (C and A) and contrast it with a fifth. The overtones of the fifth blend almost perfectly; the sixth provides more contrast although it is an acceptable chord.

Preferences in chords are to some extent learned. In other words, the physical basis is not the whole matter. Children prefer major chords, while adults find more substance in chords whose overtones blend less perfectly. The trend of musical composition in the last hundred years has been in the latter direction. From the more perfect chords of Bach and Beethoven, slight departures were made by Brahms and Debussy; modern composers such as Ravel and Gershwin have employed more and more of what formerly were considered discords. A certain amount of acquaintance with these latter composers may be necessary before the hearer becomes accustomed to their unusual combinations of notes.

Noise is arbitrarily defined as sound that has a much less definite pitch than that of a musical instrument, for example. In terms of wave motion there is no sharp crest, but the tone covers many frequencies. Noises do not cover the entire scale, however; some are deep pitched, others are near the middle of the range, and others are high and shrill. But in each case many notes are covered.

(D) **LOUDNESS,** our fourth major characteristic of auditory stimuli, needs little discussion. We have already pointed out that volume depends to some extent upon pitch; rather high tones, say in the neighborhood of 1,000 d.v., carry much better than do those which are materially higher or materially lower. Also there is the subjective side. A cough at a concert may not only be annoying, but actually startling, while a noise of several times that volume heard on the street will hardly attract one's attention.

2. The Accuracy of Localization

When we hear a sound we are usually able to judge its source within a small margin of error. We usually assist the process of localization

by looking toward a small area already limited by auditory localization. But even in the dark our accuracy of sound localization is fairly good.

Recently two studies were performed to measure the accuracy of auditory localization under various conditions. In the first the author and his associates compared the accuracy of localization in the horizontal (right-left) versus the vertical (up-down) plane. We built a large cage and placed buzzers in fourteen different positions, such as 90° to the right, 90° to the left, halfway between directly in front and directly overhead, and so on. The subject sat inside the cage blindfolded, and the various buzzers were sounded in completely random order so that no possible anticipation could occur. Here are some of the results. Accuracy was about twice as good in the horizontal as in the vertical plane. Considering only those buzzers directly in front and in back of the seated subject, arranged vertically along his mid-line, the subject was least able to place sounds which originated below and/or behind him. Possibly experience has something to do with this. In daily life a person rarely hears a sound as coming from below him; most of the time he hears it as coming from the same level or from a level slightly higher than his own. If the sound comes from behind, he is likely to turn and orient his audition to the front.

In the second study we measured accuracy of localization in the horizontal plane. In half of the experiment head movements were allowed; in the other half the head was kept rigid by braces against the cheekbones and forehead. The blindfolded subject was placed in the exact center of a semicircle of buzzers, one every 10° . When a buzzer was sounded the subject pointed in the estimated direction. The results when head movements were not allowed showed an average error of 6° , and indicated that the buzzers in front of the subject were more accurately localized than those far off to one side. When head movements were allowed, the accuracy was still better. The subject then would move his head back and forth, much as one estimates the heavier of two weights by alternately lifting with one hand and then the other. By slowly rotating his head until the strength of sounds hitting each ear seemed identical, the subject was able to center a continuous sound. Airplane detectors accomplish this same thing mechanically, but eventually direction is estimated by the operator's judgment that the sounds picked up by the two receiving trumpets, amplified, and led to his two ears are equally loud.

All in all, we can say that accuracy of localization by the ear alone is good. The error is not more than the width of a burglar's body across a room of average size; hence one should have success in aiming a pistol at an intruder. Whether it is wise to shoot the pistol is another matter,

and one we cannot solve here. By way of summary, we may list the following conclusions: [6, 8] (1) Sounds in the horizontal plane are localized with accuracy; (2) those far to one side are not so well localized; (3) those above or below are rather poorly localized (as when an unseen friend calls to one from a window in a high building); (4) front-back confusion is common. (5) Another point, not discussed heretofore, is that noises are better localized than pure tones.

3. How Direction Is Estimated

Just how do we localize the source of sounds with only a few degrees of inaccuracy? Most of this ability seems to be derived from the fact that we have two ears. More detailed study of the anatomy and physiology of the auditory system adds nothing to our knowledge of localization.

Since sounds originating from any direction other than front arrive at the two ears at slightly different times, it seems probable that localiza-

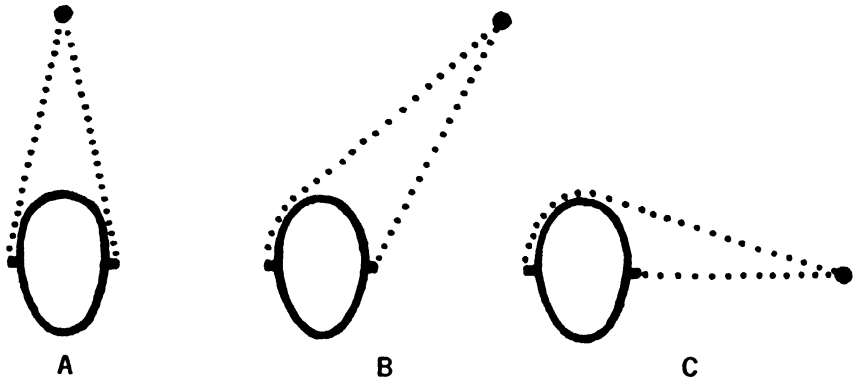

FIG. 27.—Illustrating Auditory Localization.

The farther from the mid-line of the body the sound is, the greater the difference in time of arrival of that sound to the two ears.

tion is effected by the differences in time. As we see from the three diagrams in Fig. 27, sounds from directly ahead strike the two ears simultaneously (A); those from slightly to one side (B) come to one ear slightly ahead of the other; and a sound which is far off to one side (C) not only has a greater distance to traverse, but also has to come around the head. Since the ears are only a few inches apart and sound waves travel more than a thousand feet a second, these differences are not great. But it appears that this very slight overlap furnishes the cue which enables us to tell at which side, and how far to that side, the sound originated. It has been suggested that phase difference—the fact

that the wave crest arrives at the two ears at slightly different times—may account for localization, but careful experiments have shown rather conclusively that time difference is the more critical factor. There is also the possibility that the sound coming to the nearer ear has greater intensity, but the differences are really so minute that this hypothesis also must be minimized.

The problem of localization was studied in a neat experiment by P. T. Young. [9] He devised an instrument called the pseudophone which in effect interchanged the two ears. The sounds which would normally enter the right ear were carried over the head into the passage of the left ear, and vice versa. Wearing a large, loose-fitting cap to render himself less conspicuous, Young ventured into the streets. Here are some of his experiences.

On May 14th, I stood before an open window of the institute and listened to the street sounds in front and a few feet below. The tread of horses on the pavement, auto horns, street car bells, the hum of motors, and so on, seemed to be normally localized. Once a horse came from the left to the median plane. The sound of the tread was normal in localization. When the horse reached the median plane I closed my eyes. Then the horse was distinctly heard to recede in the direction from which he came. A moment later the eyes were opened and when the horse was again seen the localization of the tread quickly became normal.

I heard a dog barking distinctly to the left-front. Quite automatically I looked towards the spot and saw some shrubbery but no dog. After a random visual search the barking dog was found to the right-back of my original position.

While walking along the sidewalk I heard the voices of two ladies and their steps approaching and overtaking me from behind on the right. Quite automatically I stepped to the left making room for them to pass. I looked back and found that I had stepped directly in front of them.

On the third day deliberate movements were made on the basis of knowledge and not on the basis of sensory localization. I found myself deliberately correcting known reversals. I heard a pedestrian overtaking me from behind on the right. Knowing that the person was actually on the left, I stepped aside to the right to let him pass.²

The last quotation suggests that the slight correction which appeared during the experiment was voluntary and artificial. The process is somewhat like shooting a rifle whose sights are crooked; the user knows that he must aim away from the target in order to hit it. But this does not prove, by any means, that localization is entirely innate; it must be

²Young, P. T. Auditory localization with acoustical transposition of the ears. *J. exp. Psychol.*, 1928, 11, 399-429.

remembered that the subject had heard all his life with his ears in the normal position, and that comparatively few hours were spent with the pseudophone.

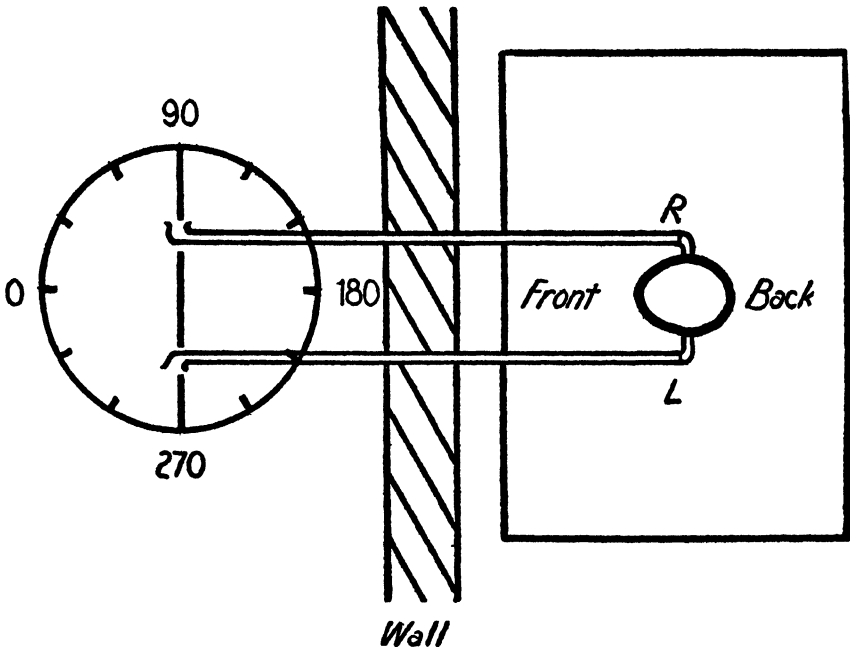

FIG. 28.—Diagram of Apparatus to Test Auditory Localization.

The receiving trumpets can be placed in any angle of the circle, and a sound stimulus administered. The wall conceals the experimental set-up from the subject. (From Young.)

Young amplified this experiment with a second which was performed under more strictly controlled laboratory conditions. [10] He led long rubber tubes through a partition, with the ends held apart exactly the same distance as the separation between the subject's ears. Then he could move these receiving trumpets about, unknown to the subject. Clicks of a telephone receiver served as stimuli. These were in various positions with reference to the ends of the tubes, when the apparatus was turned.

The detailed statistical results of this experiment do not concern us, but the general conclusions are in line with our theoretical suggestions and with the previous findings with the pseudophone. Regardless of the absolute position of the trumpets, localization was entirely in terms of the relation of the locus of the stimulus toward the ends of the trumpets.

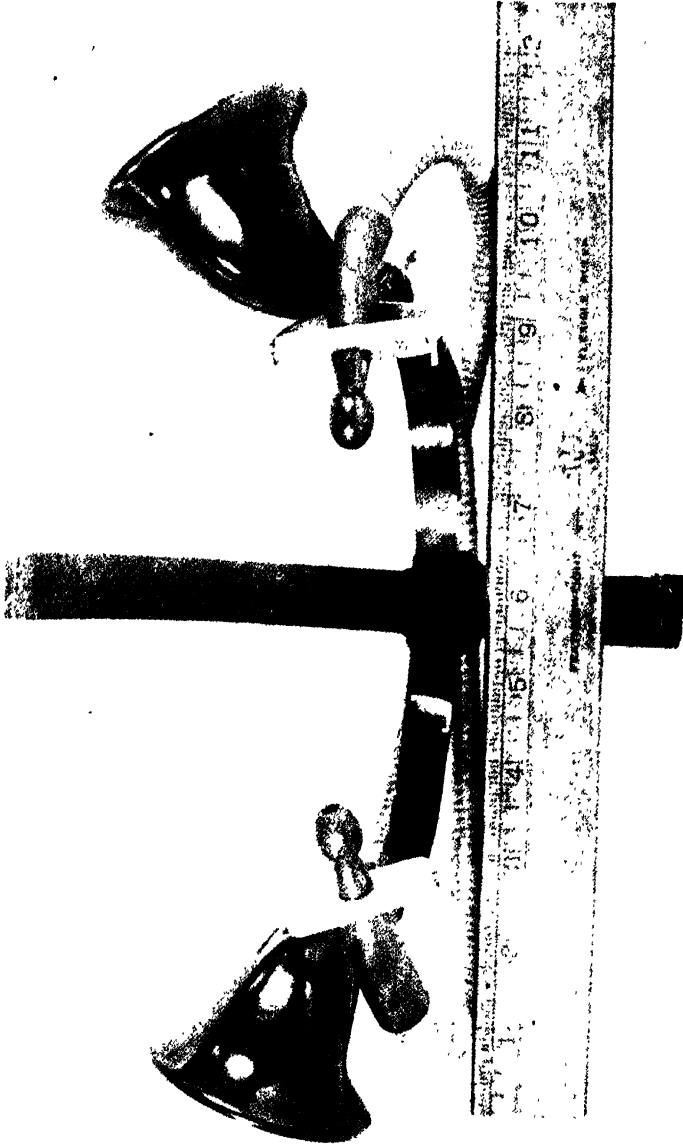

FIG. 29.—The Pseudophone.
The ear trumpet and tubes leading over the head carry to the left ear sounds which would normally go to the right ear, and vice versa.

Other cues. Not every fact of localization can be explained in terms of time differences of the stimuli hitting the two ears. This explanation cannot account for up-down localization, which may be comparatively poor, but which has decidedly more than chance accuracy. Another phenomenon is judgment of distance; again this is rather poor, but still not entirely lacking. A third item is that persons who are deaf in one ear do not entirely lose their ability to localize sounds. In a test of five persons who were totally deaf in one ear, the average error was from 27° to 63°, as compared with a departure of 9° on the part of normal subjects. [1]

Just how these aspects of localization were achieved cannot be answered on any anatomical basis. The person with one deaf ear might be able to derive certain cues by moving his head about until he found the position in which the loudest sounds were received. But a certain degree of localization is possible even on the deaf side and with the head held immobile. No satisfactory explanation will account for whatever vertical localization is possible. So we must leave our discussion with the general conclusion that the "two-ear" theory accounts for most of the facts of localization, but that some facts lie outside it.

SUMMARY

The most important psychological characteristics of sound are pitch, timbre, chords, and loudness. Pitch is the wave length, and contributes melody to music. Timbre is determined by the relative strength of the various overtones of the instrument or person's voice; it enables us to differentiate one instrument, one person's voice, or one sound from another. Chords are composed of notes whose overtones blend in well with each other; discords have clashing overtones. Loudness is a fourth phenomenon of hearing, but it needs no additional comment here.

Sounds are localized best in the horizontal plane. Those above or below are localized only with a rather wide degree of error. Sounds in front and behind are often confused. This suggests that the most important factor in localization is the time difference in the incoming sound waves as they reach the two ears. There are other minor factors: sounds which arrive at the ears simultaneously are capable of a certain accuracy of placement; a person who is deaf in one ear can localize in general, although not so well as a person with normal audition.

II. CONTACT SENSES

*SMELL, TASTE, TEMPERATURE, TOUCH, PAIN,
POSTURE*

The senses we shall discuss in this section are of less apparent importance to us in daily life than vision or audition. In social affairs especially, seeing and hearing are of greater consequence to us. At the same time we would not like to be deprived of these other receptive organs. If we should lose our sense of smell, we would be deprived of many pleasurable experiences as well as of protection from asphyxiation. Without pain we might suffer an injury without knowing it. Without warm or cold receptors we might suffer serious skin burns or freeze our toes before we realized that anything was wrong. Without sensations from muscles, tendons, and semicircular canals we might be unable to stand upright in the dark.

1. Smell

Smell is a chemical sense, since stimulation occurs only when particles discharged from the object reach the nose. For instance, witch hazel rubbed on the face after shaving ceases to emit an aroma when the face is dry. The receiving organs of smell are located in the roof of the nasal passage, where nerve fibers come through a spongy bony structure from the olfactory bulb. These nerve endings are a little off the direct path of inspired or expired air, which protects the sense against overstimulation. This is the reason vigorous sniffing is used to intensify olfaction and to enable better identification of faint odors.

Careful introspective experimentation has suggested that smells can be grouped into six chief classes:

1. Spicy: such as nutmeg.
2. Fruity: skin of orange.
3. Flowery: orchard in bloom.
4. Scorched: wool scorched.
5. Resinous: pine pitch, or pine wood burning.
6. Foul: decaying matter, such as dead cat.

Whether this, or any other, classification can be adequate is problematical. We can find examples to fit each of the six groups, but it is exceedingly difficult to fit in, say, every item of a dinner. Even complex combinations are not completely convincing. Onion, for instance, is said to be largely foul, with traces of flowery, burned, and spicy. Roses and lilacs are both flowery; yet there are distinct differences in odor.

An important fact about olfaction is its rapid adaptation. When we

enter a laboratory we may be bothered by a certain chemical smell, but after a few minutes the smell is no longer annoying. Strong odors last longer than weaker ones, but we become adapted even to them. This is a fortunate mechanism. The initial warning suffices to tell of danger, as from a leaking gas main. But if a man works in a glue factory or as a garbage collector he will rejoice that the intense initial stimulation does not continue all day. Tobacco smoking produces partial anosmia (loss of smell) and should be avoided for several hours before a subject participates in any experiment in olfaction.

2. Taste

Taste is another chemical sense; it requires a liquid solution. Sensation is produced only if the food itself is juicy or if the saliva moistens it sufficiently to allow a liquid to penetrate the taste pits on the surface of the tongue, the bottom of the mouth, and in the throat. This fact may be demonstrated simply. Wipe the surface of the tongue dry with a handkerchief, and then place a lump of sugar on the dry skin; no sensation will occur until moisture reappears. After several plain dry crackers have been eaten there will cease to be any sensation.

There are supposed to be four fundamental tastes: *sweet, sour, bitter, salty*. As with odors, the whole story does not seem to be told by such simple classification. Suppose we try to classify in terms of one or more of these four tastes such foods as roast beef, radishes, or fried eggs.

One complication is that taste, as ordinarily considered, involves not only the taste pits on the tongue, but also smell, touch, temperature, and even pain. Smell is, of course, the most important supplement. If one holds his nose and takes an unpleasant medicine, the sensation is materially reduced. Many persons lose much of the sensation of taste when afflicted with a cold. It is probable that much of the enjoyment in eating comes from the smell emanating from the food. Taste and smell do not always agree, however. Many women like the smell of cigars without desiring to indulge in them. Some people like the smell of coffee as it percolates, but find the taste unpalatable. Cauliflower tastes far better than it smells.

Certain "skin sensations" also form part of the broad field of taste. Much of the objection to castor oil is its oily texture. One person declared a definite fondness for mushroom soup if the mushrooms were strained out, but would not eat the mushrooms because of their "slimy" texture. Mashed potatoes seem to be a different substance from fried or baked potatoes. The same item may differ in desirability when served hot or cold. Some people like iced tea, but do not care for hot tea, or vice versa.

Some physiological changes in tastes come with age. Young people have more sensitive tastes than older people. They not only derive greater enjoyment from eating, but they require less seasoning and are more satisfied with the ordinary items of diet. As we grow older, we use more salt, pepper, chili sauce; and we need more unusual flavors, such as anchovy or curry, to tempt us. We also seek attractive surroundings when eating and demand more refined service; the young person's appetite is not so easily lessened by crudeness, material or social.

Liking for certain foods changes with time, with learning, and with emotionally toned experience. Here are several gustatory changes of one individual to serve as a sample.

TABLE 11
CHANGES IN PREFERENCES OF FOODS

Food	Liking Now	Former Liking	Cause of Change
Cauliflower	Fair	Avoided	Learned to eat to avoid social embarrassment
Onions	In all forms but raw	Not at all	No assignable reason
Cheese	Very fond	Disliked	
Cucumbers	Avoid at all times	Slight	Saw man faint after eating them
Coconut	Disgusting	Much	Had too many desserts containing coconut
Pancakes	Moderate	Very much	Ate them every morning for a year
Coffee	Fair	Too bitter	Gained weight from drinking milk, so forced self to take coffee

Although these illustrations may be obvious and parallel instances exist within the experience of everyone, we present them to show that a great deal of learning occurs even in a field as physiological as that of taste sensations. We learn to like certain previously disliked foods through either a brief or a lengthy effort; we lose our preference for others because of unpleasant experiences or from overindulgence; and still other foods go up or down in our estimation for no assignable reason. Since learning and change have been emphasized throughout the book, we call attention to the part they play in the sense of taste.

Many tastes are acquired. There is a theory that no one likes olives or beer the first time he tastes them. In general, children like meats and dislike most vegetables. As adults, we learn first to accept and later to enjoy a variety of foods. A person who dislikes many foods embarrasses the hostess and is unlikely to receive subsequent invitations to dine. Usually if one determines to expand his food likes he will find that after a few trials previously disliked foods can be enjoyed. Just

as in reconditioning emotions, a gradual process is advisable, especially with children. A disliked food, say spinach, should be served in small quantities, so that the child will eat all that is given him (possibly solely to get rid of it). A large helping will only intensify his dislike.

3. Temperature

(A) **HOT AND COLD ARE DIFFERENT SENSATIONS.** Entirely different nerve endings supply the skin surface for the two extremes of temperature. This may be demonstrated by mapping off a half-inch square on a hairless surface of the hand. The area is explored first with a needle that has been heated by a candle flame, and later with a needle chilled by ice. Every time a warm spot is found, indicate it with a dot of black ink; indicate cold spots by a dot of red ink. The dots will be distinct from each other, and quite numerous. Over the entire body surface, it is estimated, there are 30,000 warm receptors and 250,000 cold nerve endings.

(B) **PARADOXICAL HOT OR COLD.** An interesting exception to this rule of separateness of nerve endings is termed paradoxical hot or paradoxical cold. An extremely hot or an extremely cold stimulus will actually create the opposite sensation. This fact of physiology is sometimes used in roughhouse initiations. The initiate is told he is going to be branded, and a piece of ice is pressed to his forehead or back. His first sensation will be that of extreme heat. Likewise, if he is seated in a bathtub and puts his foot under the faucet, he may be unable momentarily to tell whether the trickle is very hot or cold.

(C) **PHYSIOLOGICAL ZERO AND PAIN.** Exposed skin surfaces are about 8–10° cooler than internal body temperature. Without one's clothes, a room temperature of about 90–91° seems neutral. Above that is warm; below that feels cool. A departure of about 30° from this mark brings not only acute temperature sensations, but pain as well. Pain appears at temperatures below about 55°, and above 115° Fahrenheit. This mechanism undoubtedly has practical value in warning the organism of potential danger, which in this case would result in severe tissue injury.

(D) **RATE OF CHANGE.** Rate of change is important in determining the intensity of temperature sensation, and possibly of pain. The water in a bathtub may gradually drop as much as 10° before one becomes aware of it. If one puts his hand into a pan of water that is being heated very slowly by a gas flame, the temperature can rise many degrees before it becomes painful. But if the other hand is suddenly plunged into the pan, the result may be exceedingly painful. If one adapts one hand to warm water and the other to cold, then places both

in water of normal skin temperature, the latter feels warm to the cold hand and cold to the warm hand. This factor of rate of change ties up with our idea of the stimulus as a change. It was demonstrated dramatically with a frog. Normally, the frog responds to excessive heat by jumping, but in one case the temperature of a chamber was raised so slowly that a frog died without a single jump or movement in an attempt to escape.

This adaptation may be on a long-time as well as a short-time basis. Since the air grows cooler gradually in the fall, a resident of the northern states suffers far less discomfort from winter than does a Floridian who comes north. After several weeks of winter weather, a temperature of 20° may seem much less uncomfortable than did the first drop to 50° in the early fall. And when spring first begins, people who shivered in fur coats at 50° in the fall may now go without top-coats at 40° .

4. Skin Sensations

There are several types of skin sensations, each received by its own nerve endings and carried in its own nerve trunks. For instance, pain is not merely a heavy touch; different nerves are involved when a shoe is felt to be tight than when it becomes definitely painful. There are six separate skin sensations: warm, cold, touch, pain, tickle, and itch. We have already discussed warm and cold.

The skin is sensitive to mechanical, chemical, electrical, and thermal stimuli. [4] The most frequent stimulus is pressure or tension, externally caused or produced by bending of the skin in movements of the skeletal muscles or from visceral distention.

(A) TOUCH. Touch involves consciousness of contact or of weight (pressure). It is caused by bending of the skin, either by direct contact or through the leverage of a hair. Hairy regions are more sensitive than smooth surfaces, since there is greater opportunity for skin distortion.

The various parts of the body have different degrees of sensitivity. This may be tested by blindfolding an individual, touching his skin surface with an ordinary drawing compass with the points set fairly close together, and seeing if he can tell whether one or two points touch him. By altering the separation between the two points, one can find the *two-point threshold*. This is small on the more frequently used parts, such as the finger tips or the lips, and relatively large in the middle of the back, which is rarely used for tactual exploration. In the middle of the back the two points of the compass have to be thirty times as far separated as on the tip of the tongue. The same principle

holds for the threshold of pressure; a weight has to be roughly a hundred times as great to be sensed on the thick sole of the foot as it does on the tongue or finger tip.

Touch nerve endings take several shapes and are located only a small distance under the skin surface. Even though these exist in great profusion, being the most dense of the contact receptors, physiological distribution alone does not account for all tactile discriminations. It is true that there are more nerve endings in the most sensitive regions, but that still does not tell the whole story. If one applies a pattern, say a small hollow square, to a given skin area and then moves it ever so slightly to one side or the other, the same pattern will still be perceived, but the underlying nerve endings will be different in their pattern. A mental fill-in has occurred.

(B) PAIN. Pain nerve endings are farther below the surface of the skin than are those for touch. Unless the stimulation is carried beneath the surface it does not become painful. Susceptibility to pain in lower layers is seen clearly enough if a sliver is run beneath the fingernail or if one touches freshly exposed skin beneath a blister. There are, however, few pain receptors in the internal organs. Certain diseases may make much headway before they become definitely painful.

Severe blows, sharp objects, extremes of heat and cold, and strong chemical or electrical applications all are adequate stimuli of pain. Also it has been noticed that extremely strong stimuli applied to other sense organs may produce sensations of pain: very bright lights, screeching sounds, concentrated chemical odors, boiling water, and the like.

Since pain warns of illness or destruction of body tissue, it has survival value. Hence pain should not be ignored or dulled by drugs more than temporarily, and then with great care. Students have had common colds turn into pneumonia by drugging themselves with aspirin, and thus being unable to perceive that the disease was spreading.

(C) TICKLE AND ITCH. Tickle and itch are often considered separate senses, but since they operate in much the same way they may be mentioned together. In general, both are produced by a light touch applied to a limited area. Susceptibility to tickling is demonstrated to be psychological as well as physiological, since it varies from time to time. At one time a person will defy all efforts to harass him, while at another he will wince at a threatening finger. Certain regions of the body are more sensitive than others, especially the soles of the feet, the lips, the inner surface of the upper arm, and near the floating ribs.

(D) COMBINATIONS. Combinations of the skin senses are found, just as we find combinations of less obviously related senses. Wetness, for example, seems to be a combination of pressure and cold. Pressure

and warmth experienced together create a feeling of oiliness. Touch sensations can be subdivided into rough, smooth, and sticky.

(E) ADAPTATION. Adaptation appears in all skin senses. The pressure of tight clothing soon ceases to be noticed. When a person has carried a knapsack several miles and then removes it, he feels as if his feet were about to leave the ground. A baseball player swings two bats while waiting his turn, so that a single bat will seem light and mobile. Pain is perhaps less subject to adaptation, but if long continued, as in a toothache, it becomes less noticeable. It is also subject to distraction. An athlete does not notice fatigue, minor injuries, or a blister until after the contest. A lively social gathering will appear to relieve a headache, although afterward it may return in double force.

5. Posture and Balance

(A) MECHANISMS. It seems a simple feat to maintain an upright posture, to balance the body while walking, or to identify with eyes shut the position in which an arm or leg happens to be at the moment. But actually the number of parts concerned and the network of nervous connections involved show these seemingly simple acts to be complex.

The principal organs used in the reception of these kinesthetic sensations are muscles, tendons, joints, perhaps the skin itself (being bent and stretched), and semicircular canals. Vision acts also in supplementary fashion. There are nerve endings buried right in the muscles, tendons, and joints, which give rise to sensations not only during voluntary movement, but also when the arms or legs are moved passively. Ability to identify such passive movement and position is employed as a clinical diagnostic test; failure suggests certain nervous lesions.

The nervous connections are exceedingly complex, and not of great interest to us. Suffice it to point out that there are branches to the cerebrum, cerebellum, midbrain, and upper spinal cord, as well as nerves serving the semicircular canals and the eyes. Active muscular movements are produced through stimulation of the receptors. These are clearly shown in the familiar righting reflex of a cat or a rabbit as it drops through space. During the drop the head is righted first; this in turn shifts the thorax; and finally the pelvis is rotated. The original movement of the neck is initiated from the semicircular canals.

An interesting observation about identification of body position is that a slight movement is usually necessary. If one asks a person whose leg is concealed under a table to tell exactly what angle his right knee has at the moment, he may be unable to tell unless he moves his leg slightly, or at least tenses his muscles in an incipient movement.

(B) SEMICIRCULAR CANALS. There are three of these canals, which operate singly or in conjunction to convey sensations of movement in three dimensions: right-left, forward-backward, up-down. These little semicircles are very minute, having an inside diameter smaller than the lead of a pencil. They are filled with fluid, which tends to remain stationary as the head rotates, just as water tends to remain stationary when a pail is rotated in a horizontal plane. This differential motion stimulates nerves in projecting hair cells, just as weeds at the bottom of a brook tend to bend in the direction the current is flowing.

As with other forms of stimulation, detection and intensity of sensation depend upon rate of change. If a blindfolded person is moved or rotated very slowly, he may not feel the movement at first. Similarly, continuous motion may cease to have stimulus value. Motion is not felt in an express elevator after it gets under way, but coming to rest may be followed by after-sensations of movement. Several hours of continuous driving often causes an illusion of the road coming toward the car, and this lasts for several minutes after one stops.

(C) VERTIGO. Vertigo, or dizziness, typically follows rapid rotation, such as whirling on a piano stool. It is produced by sensations from both the semicircular canals and the visual field. If the eyes are kept shut the unpleasant after-effects may be lessened. Dancers, in whirling, fixate momentarily on one spot after another, rather than allowing the environment to whirl past in a blur. Dizziness may come from the eyes alone; if a person looks at the near-by ground from a train window or at the water just below the prow of a boat, he may become giddy. Yet in these cases he is stationary with regard to his environment and there is no possibility of semicircular canal stimulation.

Seasickness has the same general physical causes as dizziness, but the mental side is at least as important. Many passengers on ocean liners become violently ill before the ship leaves the harbor. If a storm is encountered toward the end of the voyage after a calm early passage has given reassurance, fewer persons become affected. The rhythmical rolling of the ship in a ground swell is worse than the irregular violent pitching in a storm. Eliminating the visual by refraining from watching the horizon (apparently) rise and fall helps prevent nausea. It is interesting to observe that after a number of days on board ship the passenger has become so adapted to the motion that when he steps on land the streets seem to sway beneath him.

(D) MUSCLE SENSE. Muscle sense is of use not only in maintaining equilibrium, but also in performing many acts of skill. We

regulate the force with which we throw a ball according to the distance; we push a revolving door with the appropriate amount of strength; we press the accelerator pedal according to how fast we wish the motor to go; we reach the proper distance to pick up an object; and we lift an object of known weight with just enough strength so that we neither throw it in the air nor fail to move it. The muscle sense also furnishes us distance cues, as when we find our way through a dark house, avoiding furniture and going through doorways. The expert comptometer operator judges small distances with complete accuracy and without visual cues. These acts involve both sensory and motor components. If man received no sensory cues as his muscles operated, he would not be able accurately to regulate the movements. He might reach past an object, step too high in ascending a staircase, or lift an object with too much or too little strength. He might be unable to touch his finger to his nose if his eyes were shut.

REFERENCES

1. Angell, J. R., & Fite, W. The monaural localization of sound. *Psychol. Rev.*, 1901, 8, 225-246.
2. Best, C. H., & Taylor, N. B. The physiological basis of medical practice. New York: William Wood & Co., 1937. Chapter LXVI.
3. Miller, D. C. The science of musical sounds. New York: The Macmillan Co., 1922.
4. Nafe, J. P. The pressure, pain, and temperature senses. Chapter 20 in *Handbook of General Experimental Psychology*, C. Murchison, editor. Worcester, Mass.: Clark Univ. Press, 1934.
5. Seashore, C. E. *Psychology of music*. New York: McGraw-Hill Book Co., Inc., 1938.
6. Stevens, S. S., & Davis, H. *Hearing*. New York: John Wiley & Sons, 1938.
7. Troland, L. T. *Principles of psychophysiology*. Vol. II, Sensation. New York: D. Van Nostrand Co., 1930.
8. Woodworth, R. S. *Experimental Psychology*. New York: Henry Holt & Co., 1938. Chapters XIX and XX.
9. Young, P. T. Auditory localization with acoustical transposition of the ears. *J. exp. Psychol.*, 1928, 11, 399-429.
10. Young, P. T. The role of head movements in auditory localization. *J. exp. Psychol.*, 1931, 14, 95-125.

*MOTIVATION, EMOTIONS,
AND PERSONALITY*

VII

PHYSIOLOGICAL AND SOCIAL MOTIVES

1. Mainsprings of Action

(A) **WHY DOES BEHAVIOR OCCUR?** A large part of this book will be concerned with the behavior of people. Before we can describe behavior, however, we must know why it occurs and how we can produce a desired result. Just as we want to know whether a motor is run by gasoline, steam, or electricity, so also we want to know what makes human beings behave as they do.

Why does Joe commit petty thievery? Why does a multimillionaire continue to work ten hours a day, when he could retire and live in luxury? Why do you vote for a certain political party? Why is an employee so consistently late to work that he has to be discharged? How might we make him more prompt? How can Jim and Mary be encouraged to study harder in school? How can we make a carelessly dressed friend realize the desirability of a pressed suit and shined shoes?

Motivation is the crucial issue in deciding upon a penalty for murder. If it was premeditated murder, the culprit usually suffers death or life imprisonment. If a sudden quarrel resulted in a fight and fatal injury, the penalty might be ten years. If a motorist drives negligently and kills a pedestrian, the penalty may be still less stringent. Death suffered in hunting or sport is usually considered part of the risk a man accepts when he engages in such pursuits. Finally, if a member of a sheriff's posse shoots a notorious criminal, he may even be given a reward. In each case a person dies, but the consequences are determined by the intent or motive.

(B) **MUCH OF OUR BEHAVIOR IS IRRATIONAL.** We like to flatter ourselves that we lead predominantly rational lives, but a good share of what we do is emotionally determined. Here are a few everyday

incidents: we know that we should stay at home and work, that we should not eat an extra helping of dinner, that it is high time we were in bed, but we fail to follow reason. We give in to ourselves, because we *want* to. Most people can give reasons why they lean toward a certain political party, but the reasons are frequently selfish. People with money or property are conservative and usually favor the status quo, the system under which they have prospered. People without money or jobs want a new system, since they have nothing to lose and everything to gain by a change. Radicals who receive highly paid positions often become conservative; on the other hand, rarely does a millionaire turn radical. Uninhibited emotional behavior sometimes proves costly. One divorced wife held such malice against her ex-spouse that she spread rumors which caused him to lose his job, thereby cutting off her chance for alimony.

The prominence of the "irrational" in human beings is not necessarily unfortunate or derogatory to *Homo sapiens*. The term, as we use it, refers only to behavior which is not the result of calm and judicial deliberation, and not to behavior that is totally disorganized or wholly undesirable. The satisfaction of desires and participation in pleasurable events is what makes life enjoyable. It is friendships, parties, holidays, vacation trips, and the attainment of ambitions that relieves life of humdrum monotony.

(C) **MOTIVES MAY BE UNCONSCIOUS OR RATIONALIZED.** Often we are not even aware of a motive, though it exists and impels us to action. The restlessness accompanying hunger is an example. When a person finds himself unable to concentrate, he may wander about the house. He finds himself in the kitchen, eats something, and begins to work again, all without appreciating cause and effect. Some abnormalities have their basis in unconscious motivation. A soldier who hasn't the slightest intention of "slacking" comes down with a mysterious paralysis or blindness, which enables him to escape danger but keeps his conscience absolutely clear. An elderly woman, the rest of whose family is about to leave on a summer vacation trip, develops an illness which necessitates their staying to care for her. The motivation is obvious, even though consciously she may feel distressed at having upset the family plans.

We often give very weak reasons to justify doing what we want to do. The week school opens students go to the movies, rationalizing that they need the relaxation. We spend more than we should for a certain item, and justify it by saying that our morale needs bolstering.

(D) **MOTIVES ARE BEST INTERPRETED FROM ACTUAL BEHAVIOR.** As pointed out in Chapter I, there is often a discrepancy between what

a person says he intends to do and what he actually does. At the beginning of the school year many students announce their intention to work harder and earn higher grades, but their actual conduct soon demonstrates the weakness of their motivation.

It has been suggested that we can estimate *crudely* the relative strengths of various desires by the money spent for different commodities during the year. [16, 17] In one year the American people spent \$17 billion for food, \$8 billion for clothing, \$6½ billion for automobiles, and \$1½ billion for tobacco. Thus, food seems to be roughly twice as important as clothes and automobiles four times as important as smoking. Twice as much is spent for travel as for insurance; hence we might gather that this form of pleasure furnishes twice as strong motivation as protection. When complaints are heard about the high cost of education it would be enlightening to compare the amount spent on education with that spent on tobacco.

Such monetary comparisons are merely suggestive at best, since some items are necessities, others luxuries, some have high unit costs, others low. Necessity, not motive, sometimes dictates how money is spent. A traffic fine is paid instead of having dinner in town and going to a good show. A severe illness may require a financial outlay equal to that of a long-awaited trip to Europe. Nevertheless, actual behavior as reflected in comparative expenditures does afford a crude index to incentives.

(E) **MOTIVES ARE OFTEN PERSISTENT.** One of the distinguishing characteristics of motives is that they persist in time, although the ordinary stimulus-response situation endures for only a brief period. We may be so intent upon finding a certain item of food that we will walk all over town until we find a store that has it in stock. A boy may decide to become a physician and work hard in school for many years to achieve that ambition. The person who overcomes obstacles to rise from poverty to wealth and prominence illustrates the strength of persistent internal motivation; also, the fact that man is not stimulated entirely by external stimuli.

2. Physiological Motives

A number of drives are produced by internal stimuli, largely biochemical in nature. Some of them demand action; others demand cessation from action.

(A) **HUNGER.** Hunger is primarily caused by stomach contractions which take place when the stomach is empty. These are rhythmical, occur in waves, and give us hunger pangs. Food deprivation is naturally the principal cause, but there are certain other variables. Some of them

are: age, illness, strong emotions, length of time since the last meal, the amount eaten then, and whether the time since the last meal has been spent in exercise, office work, or sleep.

But there is more than the emptiness of the stomach in the production of hunger. In the first place, all foods are not equally attractive. Many people do not care for liver or spinach; they will partake sparingly of these items even when very hungry. At times one may go to a lot of trouble to find an especially desired dish, such as chop suey or sauerkraut. It has been suggested that craving for a certain food at a certain time represents an unconscious motivation due to a shortage of the essential chemicals contained in it. Furthermore, we have a tendency to eat by the clock. We eat dinner at about the same time every night, regardless of whether we have exercised, slept, or relaxed during the afternoon, or whether we have had lunch an hour late.

Finally, we cannot pass over the social superstructure built around the process of eating. The offering of food to a guest is a social compliment. The hostess takes special pains not only to have good food, but to prepare choice and unusual dishes, use fine china and silver, and set the table in an attractive manner. We enjoy a meal more in a luxurious dining room with snowy-white napery and polished silver than in a cheap restaurant with porcelain enamel tabletops, thick dishes, and utensils of doubtful cleanliness, with a waiter shouting orders in slang through a window. In the latter case, we are likely to eat a small amount in a hurry and leave. Even the table manners of our companions influence our appetites and enjoyment. A companion who violates certain rules is not a desirable associate and probably will not be asked to join the group again.

(B) THIRST. Thirst is of two types, true and false. True thirst represents genuine dehydration, a phenomenon which occurs after working several hours in a hot sun. False thirst occurs without water loss, when the throat is temporarily dry, as after running to catch a bus, smoking, in certain types of colds, and even in excitement. False thirst can be relieved by gargling water, without swallowing. True thirst may also be lessened temporarily in a similar manner.

(C) FATIGUE. Fatigue follows prolonged exertion and requires rest, preferably sleep. Its effect upon motivation is negative; the more tired a person is the less he desires to do anything. But fatigue itself is in turn partially dependent upon motivation. Boring tasks tire one much more quickly than interesting activities. We may play tennis for hours, but a half hour spent in weeding the garden leaves us exhausted!

(D) SEX. Sex is a chemical drive. Gonadal secretions are responsible not only for the primary sexual drive and for fertility, but

also for such secondary characteristics as muscular development, beard, voice, bodily contour, and possibly even some aspects of personality. This is proved by the fact that bodily changes occur upon removal of sex glands, and to some extent upon their cessation of function with age. Possible rhythmic character of the sex drive has been the subject of much speculation. It is largely rhythmical in lower animals, most of whom are attracted to each other only in a limited mating season. In human beings the heating of houses and wearing of clothes adapted to the temperature have largely eliminated this factor.

The learned and socially inspired components of sex are of extreme importance. No human being expresses himself or herself as directly and uninhibitedly as does an animal. Sex expression may be totally repressed—not possible in hunger or thirst—and the individual will survive. In many unmarried people and in certain religious orders there may never be direct sexual expression. The drive is present, but it is not expressed. Before marriage there are certain partial and indirect satisfactions. Very indirect expression is exemplified in walking home from school with a person of the opposite sex, in mixed parties, and in dancing. Partial satisfaction may be derived from flirtation and kissing.

(E) MATERNAL BEHAVIOR. Maternal behavior is the subject of much contention. In animals it is largely, perhaps almost entirely, innate. Animals display highly complex and appropriate behavior without previous practice or opportunity for learning. A mother rat, heretofore thoroughly tame, becomes quite fierce after her young are born, as many scientists have found to their sorrow by experiencing bitten fingers. National park rangers warn tourists to be careful not to walk or drive between a mother bear and her cub, lest the visitor be attacked. The chemical nature of the maternal drive has been shown by experiments where injection of prolactin, a female hormone, into virgin rats has produced lactation and strongly maternal behavior. Occasional departures are seen, where mothers eat or otherwise maltreat their young, but these must be considered more in the light of exceptions than as general.

Among human beings the situation is much more complex. A woman may refuse to bear children because it interferes with her business career or social contacts. An unmarried mother may abandon or even kill an illegitimate child. If motherhood were entirely instinctive, factors of social approval would be of slight importance. In human beings maternal love seems to grow with time. Women occasionally resent the inconvenience before and after the birth of a child, but after a few months they willingly give up social contacts and insist upon

devoting themselves entirely to the care of the infant. Physiological and biochemical changes are greatest before and around the time of birth; hence any delay in the awakening of the so-called maternal instinct necessitates its being considered learned. There is a further contrast with animals, in whom the maternal drive seems to awaken precisely with the beginning of lactation, a few hours after parturition.

(F) AVOIDING PAIN AND SEEKING THE PLEASANT. This is a general heading which may include a number of miscellaneous motives which cannot be treated concretely. As a rule, animals avoid extremes of cold, heat, wet, and rough surfaces; and seek warm, dry, shady, and smooth surfaces. Human beings have the same tendencies, but again they are somewhat complicated by social factors. A soldier will advance in a charge even though he is "half scared to death," so that he will not appear to be a coward. Thousands of people stand for hours in soaking rain to see a president inaugurated or to hail a courageous aviator.

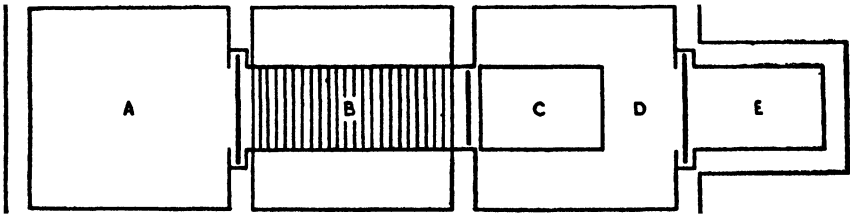

FIG. 30.—Ground-Floor Plan of Obstruction Apparatus.

Warden's Obstruction Box, used to test strengths of various drives. See text for discussion of the ways this apparatus can be used.

(G) THE RELATIVE STRENGTHS OF DIFFERENT DRIVES. Efforts have been made to study food versus thirst, food versus sex, maternal drive versus escape from pain, and the motivating power of different amounts of reward and punishment. Studies of the more complex motivating forces will be discussed in the next chapter.

One common way of approaching this problem is by means of the *Obstruction Method*, devised by Warden. [21] This apparatus is portrayed in bird's-eye view in Fig. 30. The animal is placed in Compartment A and the reward in D or E. To obtain the reward the animal must cross through the narrow tunnel, B, which has an electric grille on the floor and gives him mild but unpleasant shocks as he runs across. He is given a small portion of whatever reward is offered, such as a nibble of food, and then returned to Compartment A, where he starts again. The numbers of times a rat would cross the grille in twenty minutes were counted, with the following results:

TABLE 12
NUMBERS OF CROSSINGS FOR VARIOUS INCENTIVES

DRIVE	AVERAGE NUMBER OF CROSSINGS
Maternal	22.4
Thirst	20.4
Hunger	18.2
Sex	13.8
Exploratory	6.0
No incentive (control)	3.5

It must be emphasized that these results cannot be accepted as a final comparison of the strengths of the drives. Different animals respond differently, so that the statistics cannot be taken any more literally than the figure of 3.3 children per average family. Further, shifts of motivation crop up with various lengths of deprivation. A day or a week without food or water would arouse far greater motivation than the same time away from sex or litter. With all these qualifications, then, we must consider this investigation more in the light of a promising technique than as a means of furnishing definite conclusions.

In a series of studies Tolman and his co-workers tested the effects of giving rewards at various stages of learning, of removing it, of changing rewards during learning, and of various degrees of motivation. Food reward was given rats at different stages of learning. [3] One group found food at the end of the maze from the very first, the second was given it from the third day on, and the last group received no reward until the eighth trial. We see from Fig. 31 that practically no reduction of errors took place until after the animals began to obtain rewards for doing their task. The group which was rewarded from the outset showed an immediate and constant improvement. In a second experiment the reward was removed when the animals were well along in their learning. [4] We see (Fig. 32) that the act immediately suffered serious deterioration. In still another experiment the degrees of hunger and reward were varied. [18] The chief findings were that the more hungry and more thirsty animals learned more rapidly than those having lesser organic needs, and that hungry animals learned more rapidly when motivated by food than by water.

Can we apply the results of these last few experiments to human behavior? In this case we can, although we can by no means transfer the results and conclusions of all animal experiments. The conclusions we are about to suggest have been confirmed in experiments on human beings, although, because of many more variables, the latter do not give such clear-cut results. (1) More and better work is done if a definite goal or reward is to be attained. (2) Performance is enhanced if the

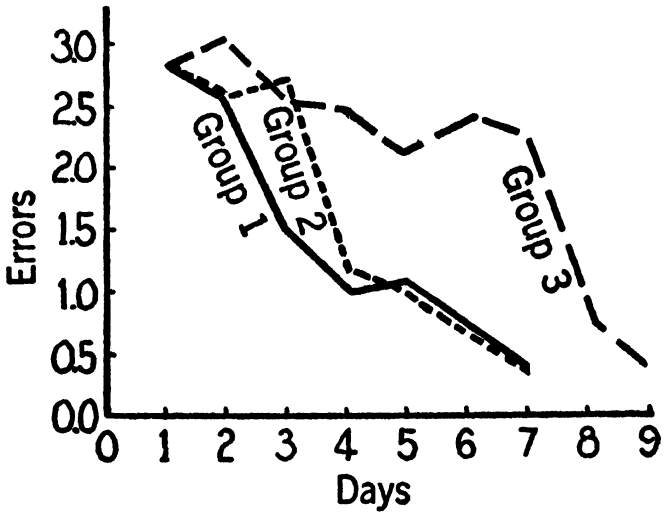

FIG. 31.—The Effect of Introduction of Reward upon Learning.
 The rat learns very little until food is introduced; then his error curve drops rapidly to the base line.

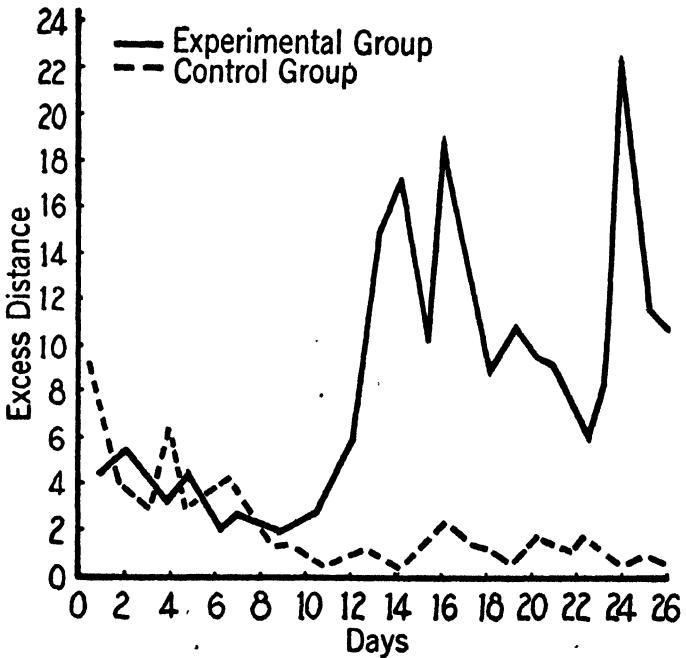

FIG. 32.—The Effect of Removal of Reward upon Learning.
 After the ninth trial no more food was given the rats at the completion of each trial. See how much excess distance was covered, possibly in search of food.

reward is appropriate: food or its equivalent in money to the hungry man; social prestige to the rich man. (3) The greater the desire the more persistent and powerful will be the effort put forth. (4) If the goal is lost or is inappropriate, indifferent work will be done. Students from wealthy families often do work far below their real abilities. Persons inheriting money often lose vocational ambition and the desire to win promotion and recognition. (5) Interest tends to cease after the urge has been gratified. After a hungry person has eaten a full meal, he not only does not wish more, but he may even be disgusted by being offered more food or being asked what he would like for the next meal. Thus, we see the physiological justification for the practice of serving a light, sweet dessert at the end of a heavy meal.

As in all phases of psychological make-up, we encounter individual differences in these physiological drives. It is quite possible that the differences are not so great as in more complex and purely psychological traits; nevertheless, there are distinct variations between one individual and another in the strength of drives. As the old saying goes, "Some people live to eat, others eat only to live." Some people have overpowering sex drives; others are rarely tempted to stray from celibate habits. Likewise, we find wide variations in need or desire for sleep, drink, or exercise. Society attempts to equalize these by impressing upon those with strong drives the need for inhibition or moderation, but with only partial success.

3. Instincts as Driving Forces

The word "instinct" is heard in popular conversation about as often as any psychological term. Nearly always it is misused. The psychologist tends to shy away from its use, because it has been used so loosely and in so many different ways that the term has lost any single precise meaning.

Some of the more commonly mentioned instincts are those of religion, music, leadership, acquisition, constructiveness, aggressiveness, criminality, self-protection, and sex. They are called instincts because many people consider them powerful innate forces. Twenty or thirty years ago it was the vogue for psychologists to list anything of this sort as an instinct. Several books gave lists of more than a hundred so-called instincts. To curb this overuse, critics have suggested various criteria to which behavior must comply if it is to be accepted as a true instinct. All agree that it must be innate, hence not learned. Others variously demand that it should be uniformly present in everyone, should have a persistent driving force, and should be difficult to change or modify.

No single trait measures up to all criteria. The so-called instinct of religion might be disqualified because not everyone is religious, and because the practice of religion varies so widely among groups and individuals. The adherents of the religious instinct answer the latter objection on the basis that the exact form of expression is not the important thing; it is the central "core" that counts.

Another difficulty is that instincts are greatly overlaid with learning. The sex instinct is modified before it ever appears. Usually before we arrive at the age of puberty a parent or some other elder tells us some of the "facts of life" and warns us of a number of things we should not do. Yet the sexual drive is not held wholly in abeyance. We go to dances, we have dates with girls, we write to "the girl" in our home town while away at school, and sometimes we even kiss her! These are partial form of expression of a more fundamental urge. But the modifications are far more extensive than the basic core.

Workings of the maternal drive are similarly complicated by learning. If it were a true and complete instinct, a mother should be able to care for her young adequately without outside help. Why all the doctors, books, special diets, and routines that seem to be necessary to bring up a child properly? In human beings it is doubtful if even the fundamental activities of protecting, nursing, and loving are wholly innate.

The most common misuse of the term "instinct" by the layman is to apply it to thoroughly learned habits. We read in the sports pages that a boxer, although groggy, fought on "instinctively" or that a baseball player, blinded by the sun, stuck out his glove and caught a hard line drive "by instinct." A good man has "the instincts of a gentleman." Perhaps a real "gentleman" should have no instincts at all. An expert jeweler is able to differentiate "instinctively" between a valuable and a mediocre gem. Actually these people have performed these acts so many times that they do them without thinking, but the acts are not and cannot become instinctive. The one indisputable criterion of an instinct is that it should be inborn, and these acts are not.

Do we have any instincts, then? Since the problem is so controversial that no two psychologists will agree on any list, we can suggest no satisfactory answer. It seems to be agreed that human behavior is so complicated by learning, experience, and thinking, that instincts play a much smaller role than with animals. And these same complications obscure detection of their presence in human beings. The most we can say is that certain forms of behavior seem to contain a large measure of the instinctive, since they appear to be predominantly innate and to exert strong driving forces. Most of those functions which may be

instinctive are the physiological drives which we have been discussing in this chapter: sex, hunger, nursing, sleep. Possibly self-preservation and acquisition can be included. Self-preservation (ego-instinct) is so strong that a man will do almost anything at the point of a pistol, will give up information on threat of torture, and will even risk social ostracism to save his life. When a person gives his life to save another, it is so rare an occurrence as to merit great publicity. It is said that acquisition is learned. However, partial evidence of its innateness may be found in the histories of communal societies that have unsuccessfully attempted to abolish private property. Some writers say that children cannot be reared to adhere to such an attitude toward property. Other writers say that it is unfair to base any conclusions about behavior upon communal societies that exist as only partially "isolated" islands in a capitalistic, property-holding system.

4. Power of Society

Under most conditions of daily life, motivation is largely social in character. We pointed out in the preceding section that even physiological motives are greatly modified by social pressures. Social customs, social pressures, and social inhibitions surround the expression of all drives. There is also a multitude of incentives entirely social in origin and nature.

Social pressures have influenced us so much all of our lives that it may never have occurred to us how fully our lives are ruled by them. Most of us accept such pressures as unavoidable. It is easier and more conducive to peace of mind to accept convention. Some of us rebel inwardly and perhaps grumble a bit, but only a few dare to defy openly the customs of our community. Sinclair Lewis's *Babbitt* and *Main Street* show how a person, if he wishes to take a better place in his firm or his community, is forced to conform.

(A) PRESSURE TOWARD CONFORMITY. The social group in which we move determines much of our behavior, over a long as well as over a short period. The group may be local, may represent a section of the country, or may even cover the whole country.

Pressures change from time to time. Styles in personal adornment illustrate this. If this season's dresses are ankle length, or knee length, or intermediate length, women follow the fashion even if it means discarding clothing which is still in perfectly good condition. Although there is no absolute conformity in hair styles, pronounced trends occur in the proportion of women having long or short hair, or even in the length of the bob. The same is true with men's mustaches and beards. The amount of make-up acceptable to society has shown remarkable

changes; if the average girl of today had "painted" thirty years ago, she would have been regarded with some suspicion. Men's clothes undergo fewer and slower changes, but some trends are noticeable. Bow ties at this writing are "out" perhaps by the time this book is used they will be approved again. Summer clothing has become slightly more comfortable, and there is more color in shirts and ties than was evident five years ago; but the very slowness with which men accept *changes demonstrates the force of social conformity.*

Conformity to the moral code is even more stringently enforced, but this, also, is subject to change. Moderate drinking is permissible in one community, and strictly taboo in another. Smoking on the part of women is subject to social regulation, rather than legal. Similarly, relations between the sexes and the question of chaperonage vary from one decade and from one locality to another.

If a person aspires to belong to a social group commensurate with his economic status, he must do more than demonstrate vocational competence. He must live in a certain part of town, entertain certain people in a certain way, and even purchase a new car at regular intervals. Such customs must be followed regardless of personal preferences or budgetary considerations. To refuse is to run a certain risk of social ostracism.

A similar situation exists with regard to college education. The mere fact of going to college often represents social conformity on the part of parents and students. A professor once asked a college girl, who seemed bright but was doing poor work, just why she had come to college, since she was apparently not willing to work hard enough to profit from it. She looked surprised and replied after a moment that she had never even thought of not going! If students wish for social success, such as joining a leading fraternity or sorority, they must conform carefully to the mores of that group.

(B) PUBLICITY AS INCENTIVE. Many acts are inspired by a wish for publicity, and many more are inhibited by fear of undesirable publicity. Newspapers often publish the names of those who give to community charities. Ostensibly this is done to show proper appreciation, but publication of such lists leads many to give who otherwise might not, and inspires others to contribute more generously.

The avoidance of unfavorable attention may have even stronger motivating value. Many people admit that they would not mind serving a short sentence in jail if no one were to find out about it. Suppose you were on a trip, and were put in jail for five days for disturbing the peace, a thousand miles from home where no one knew you. Contrast this with receiving the same sentence at home, with the whole story on

the front page of the local paper. At home, a person may put up with being short-changed⁷ or having someone shove in line ahead of him, rather than appear quarrelsome, but away from home he might not behave with such restraint. In time of war many men enlist to avoid criticism. A friend of the author's was in the counter-espionage service, assigned to locate German spies in a French city. His duties required that he wear civilian clothes, and he found to his embarrassment that he was constantly reviled by townspeople who could recognize him only as an able-bodied young man not in military service.

5. Ego

Ego, as we speak of it here, is akin to the familiar terms "self-respect," "pride," or "will-to-power." Our ambitions and aspirations, and a good share of our daily behavior, result from the working of the ego.

(A) PRIDE. Pride makes each one of us think his way of doing things is the best. An auto driver who passes us is reckless; one whom we pass is a slowpoke. A student who has more dates is girl-crazy; one who has fewer is a woman-hater. A student about to graduate discussed with two different professors the best time for marriage. One, who himself had married upon graduation, urged early marriage. The other professor had married at thirty-five, and he pointed out the advantages of a few years of independence. Our pride makes us defend our choice of a café or a movie, even if the meal or the entertainment was poor, rather than admit bad judgment.

Pride in one's place in society is the reason white-collar jobs are overcrowded and underpaid, while mechanics are sought after and earn better wages. As one clerk put it, "When you leave the office, you could pass for president of the company. In overalls you never could." Many people pay in a lower standard of living for the privilege of wearing a white shirt and a suit to work.

(B) ATTENTION-GETTING. Attention-getting is a means of bolstering the ego. A recent cartoon illustrated this effectively. It showed a typical summer resort scene, with a boy of about ten shouting to his sister, poised on the end of the springboard, "O.K., sis, you can dive now; all the boys are looking." If she had felt sure of her attractiveness, such posing would not have been necessary.

This attention-getting mechanism serves to call attention to things in which one excels. A newly rich person will buy conspicuous jewelry to call attention to his wealth; after all, one can't flash his bank balance in the face of strangers, but one can flash a diamond. Consciously and deliberately calling attention to one's actions is going one step farther.

Students often brag about how fast they drove between two cities, how little sleep they need, or how little studying they do—all to gain a little attention.

(C) **PATHOLOGICAL LYING.** Pathological lying is a means of keeping up self-respect by spinning fanciful yarns even when there is no practical good to be gained from them. Here are two examples.

W.M. is a college instructor with social aspirations far higher than his limited means will permit. Continually he represents himself as the crony of senators, governors, and university presidents. On a purely pleasure trip through the west during a summer that happened to precede a presidential campaign, he told everyone he met that he was engaged in making an official survey of the western states for the Democratic party. One summer he visited England, and met there some person with a minor title. Several years later he was telling in great detail how he had become a friend of the Duke of York. Last year, he described in even more detail how he had been presented in court to the King himself.

B.S. is a middle-aged man of good education who has not been able to get along with people, and so has been unable to keep positions in the better occupations. Now he is engaged in relief work. He constantly brags about his linguistic ability, his knowledge of the sciences, and his relations with important people. He tells of long discussions with the captain of one of the famous transatlantic liners, during a voyage when he was travelling third class. Although anyone who has traveled knows that a third class passenger seldom sees the captain, he insisted that the captain had found his company quite stimulating.

The student of psychology will recognize that in both these cases the ego is being bolstered by gross exaggerations. Only the bare elements of truth are present, but the narrator has told the stories so many times that he believes them implicitly. These stories are harmless enough; they may even be of value in certain circumstances. When one sees through the exaggerations there is no need to call attention to the contradictions. Often it is better to play the game by expressing interest and admiration. Such pathological liars may actually be among the more pleasant and entertaining of our acquaintances.

(D) **LOSS OF SELF-RESPECT.** A human being who has lost his self-respect is indeed an object to be pitied. It does not make a great deal of difference just what a person takes pride in—physical strength, wide experience, vocational competence, social prowess, family eminence, or even beauty. But people should feel pride in something about themselves, and their friends should encourage such pride. One should be careful about deflating another person's ego, particularly if the other person isn't especially outstanding. If the person is an equal, or the

leader of the crowd, a laugh at his expense may do him no harm; but if he is rather inferior he may take a slur to heart much more than appears on the surface. For the same reason, it is better to play up to the braggart, rather than to show him up as such.

6. Competition and Rivalry

It is well known that competition spurs us to greater achievements. In athletics, especially where strength and endurance are paramount, this is quite evident. In actual races distance runners do far better than in practice, and in basketball games players show more endurance and speed than in daily workouts. In performances requiring courage, competition is also inspiring. In downhill ski races, competitors will hurl themselves at breakneck speeds down slopes that inspire considerable caution in daily practice. However, in sports requiring delicate coordinations, the competitive performance may be poorer than the daily trials. Golf is a good example. Amateurs often fall down many strokes in tournament play. Even experienced professionals often have their best rounds in practice sessions.

Competition often spurs performance because the motivation is increased by rivalry, say between two schools. A person is more determined to defeat a rival than a teammate. Further, close competition is usually necessary to establish a new record. Rarely does the athlete who wins by a large margin break a record. Close competition sometimes forces not one but several of the competitors to do better than they have ever done before.

A group of boys was required to squeeze a dynamometer, to test strength of grip. When they squeezed it in the presence of other boys, they averaged 11 per cent better than when alone. Even chimpanzees pulled in heavier boxes when they had a cage mate. [7] In another test, children were asked to pull in little red flags by means of fishing reels; thus each contestant's position was always evident. Most of the children did better under competitive conditions, but a few became so excited that they failed to coordinate their movements. [19]

The chance to succeed may make a vast difference in motivation. If a person thinks he has no chance of winning he will make only half-hearted efforts, but he will redouble his efforts if he discovers that he is doing better than expected and has a chance to succeed. This occurred in a true-life situation with two big-league baseball teams. They were practically tied near the end of the season, and were to meet in a crucial game, which was featured in the newspapers as the \$100,000 game (the winner's share of the World Series money). The team that won this game went on to win practically all their remaining

games, while the losing team became discouraged and won few after that. This same problem was tested in a controlled experimental situation by Vaughn. [20] He had ten subjects of widely different abilities and experience practice rifle marksmanship one hour a week for twelve weeks. During the first six weeks they merely practiced, to acquire experience and to give an index of their relative accuracy. During the next three weeks various types of incentives were supplied, and during the final three weeks they were given more practice without special motivation. Three goals were set: highest score, highest score on handicap basis, and greatest improvement. When the experiment had been concluded, the targets were studied to see which motivation had caused the greatest improvement in each subject. The findings were interesting and instructive; namely, each individual did best under the conditions most favorable to his degree of skill. The experts did best when the competition was for highest score, those who started poorly worked hardest for the prize for improvement, and those who were fairly experienced but not especially proficient did their best under handicap competition.

Success, it must be noted, does not always demand winning. It means attaining the desired goal, whatever that may be. An athlete who is winning too easily may lose motivation; this occasionally leads to an upset, where the less skilled player defeats the favorite. Possibly the best condition for improvement of skill is to compete against a person who is slightly better than oneself, but not out of one's class. A person may be highly motivated even when he is certain to lose. A mediocre tennis player pitted against the state champion may work hard to win a single game, and derive great satisfaction from attaining that goal. And the champion may be dissatisfied with himself, even though he wins, if his performance did not come up to his own expectation.

A definite reward is not always necessary. Publicity, intangible in itself, may constitute sufficient reward. A teacher kept a study hall of junior high school pupils amazingly quiet by the simple expedient of posting a silver star opposite the pupil's name for each day of good behavior, and a gold star for a week's silence. In an experimental study, it was found that children improved in arithmetic several times as fast when stars were posted for good performance than when there was no recognition.

7. Reward and Punishment

In daily life it is a common practice to enhance incentive by giving verbal praise or blame, or by using other forms of reward and punish-

ment. There appear to be differences in expectation of reward as we ascend the evolutionary scale. Rats and other animals below monkeys refuse to learn new acts unless given a definite reward after each trial. Monkeys and young children often solve problems just for the fun of doing them. After chimpanzees have learned to hook food with a stick they sometimes amuse themselves by raking in pebbles and other objects having no intrinsic desirability.

(A) PRAISE AND BLAME. Praise and blame are verbal incentives, but effective nevertheless. In arithmetic tests children who were upbraided improved less than those who were praised, and those who were ignored showed the least gain. [1] Yet differential findings appeared when groups were separated into age and intelligence levels. The younger children responded better to censure, possibly because it was a contrast to the usual coddling a young child receives. [13] The brighter children improved more rapidly after being reproofed, and the duller derived more motivation from praise. [15] These results suggest that the *motivation should be given in terms of contrasts*. Bright children are accustomed to receiving high marks and being praised for them. The duller ones have always done poorly and are often "bawled out" by teachers and parents. Continuation of the same incentive means little; a reversal in treatment may have desirable results.

College students were given one test under identical conditions and then were divided into one control and two experimental groups for a second test. One group was told that they had done well, and that their performance suggested a high degree of intelligence. The second group was told that their first test was decidedly inferior to the average and that it was a reflection upon their intelligence. The results, summarized in Table 13, demonstrate again that a definite incentive brings about far more improvement than does no evaluation. Yet the approved group did only slightly better on the second test than did those who were told that their initial learning performance had been poor.

TABLE 13
AVERAGE SCORES OF CONTROL, PRAISE, AND REPROOF GROUPS [22]

Group	First Test	Second Test	Difference
Control	19.6	20.3	+0.7
Praise	20.7	26.4	+5.7
Reproof	20.8	25.3	+4.5

Very similar results were obtained by Sears. [14] He divided, on the basis of preliminary practice, college students into two equal groups, and had them continue practice in card sorting. He praised members

of one group, in terms both of their relative performance as compared with others within the group and of improvement of their own records against their previous time scores. To the other group he uniformly reported relative failure. The success group continued to show improvement; the failure group lost instead of gaining speed with continued practice.

It may be further recommended that one should be sparing of any type of motivation. Praise should come seldom enough so that the recipient gets a real "kick" out of it, and blame rare enough so that the person realizes he has really done poorly. Constant and frequent use of the same type of treatment soon ceases to furnish incentives.

(B) KNOWLEDGE OF RESULTS. Does the person who knows exactly how well he has done receive inspiration to do better? To put the question in a concrete way, will a high grade on an examination inspire a student to do still better, or will he relax his efforts? Will the person who has not done so well become discouraged or will he try doubly hard?

In motor tasks there is undoubtedly great advantage in knowing the results of one's efforts. In golf, typing, or industrial work the worker needs to know what he did last time in order to improve on the next attempt. Accuracy in golf is improved by watching where the ball went on the last shot, and by making an allowance for error in distance and direction on the next shot. The golfer has no other way to correct his mistakes.

In a certain industrial situation, production increased considerably when each man's output was posted without additional comment. The men were not ranked, there were no suggestions of dismissal or promotion, nor was there any expression of dissatisfaction with the amount of work done. It may be assumed that each man looked at his own record, compared it with others', and derived motivation in this way.

(C) PHYSICAL PUNISHMENT. Several experiments have tested the influence of electric shock upon performance. The consistent findings have been that learning is rendered more efficient by administration of a moderately painful shock as punishment for mistakes. In maze learning Bunch found that fewer trials are needed, fewer errors are made, and somewhat less time is taken, even though subjects become cautious in order to avoid the shock. [5] Too severe a shock so confuses the learner that he cannot concentrate well, and with fear of pain always in the background, learning is actually hampered. This is proof that improvement is not always in direct proportion to the physical strength of the motivating force. In one experiment it appeared that giving a shock during the first four trials produced as favorable results as when

it was given during eight or twelve trials (on a maze which took about sixty trials to learn). [6] Apparently a "mental set" of caution and accuracy was encouraged. This conclusion suggests possible disciplinary applications.

If a child does something undesirable, should we punish him or would it be better to guide him through the correct and desired act several times? Some writers say not to punish the child at all; a few extremists even argue that it is inadvisable to inhibit a child in any way. There is no real evidence in favor of the latter method. At the other extreme, brutality and nagging also have an undesirable influence upon the development of a healthy personality. There is definite evidence that mild punishment is beneficial, under two conditions: (1) that it come immediately after the act has been committed, not "when daddy gets home"; and (2) that it be certain to come; inconsistency of punishment on the part of the parents will not permit the forming of proper habits. Bribing the child to do what he should is bad practice. Life isn't like that. As adults we don't get pennies, or dollars, for hanging up our clothes or eating our spinach. If the parent desires to use the reward method, he may give the child an allowance, contingent upon keeping his room neat, mowing the lawn, or performing some other routine duty.

The same principles hold for the treatment of criminals. No one is rewarded, except in intangible personal or civic pride, for being honest and law abiding. Hence it is assumed that if a person fails to follow a proper mode of living he will be punished. Punishment may be softened under certain circumstances, such as for juvenile offenders, first violations, and for good behavior while serving a sentence. This last reward is given on the theory that the convict has shown himself fit to resume his place in society. His sentence is shortened as reward for past good behavior and as a token of society's hope that he will remain "on the straight and narrow." Severity of punishment by itself is conceded to be ineffective; this was realized long ago in England when men were hanged for such minor offenses as stealing sheep. Sheep still were stolen. Certainty of detection, with a light penalty, is a far greater deterrent to crime than is severity.

8. Social Facilitation

In Section 6 of this chapter we discussed the incentive values of competition and rivalry. We saw that merely being one of a group altered performance. This effect has been termed "social facilitation." There are two main results from working in a group: (1) the quantity of work increases and (2) the quality of work usually decreases. [12]

For instance, in typewriting contests, contestants type more words per minute, but they suffer a great increase in errors. In one experiment grade school children were given practice for ten minutes a day in adding six three-place numbers. [9] Those working in groups where rivalry was stressed had gained 41 per cent over the control group by the end of the experiment. Their accuracy also improved slightly—a maximum of 8 per cent—but even such a small improvement does not always appear to be the case.

Psychologists and sociologists scout the idea that there is any such thing as a group mind. There is, and can be, nothing more than a number of single minds. But it is true that a person's conduct in a group may differ from his conduct when alone. Law-abiding citizens join lynching mobs and students crash the doors of movie theaters under protection of the anonymity of a crowd. Each person is an individual, but the excitement of a crowd is so infectious as to cause widespread loss of emotional balance.

The quality of ideas usually suffers in a group situation. It is for this reason that the affairs of large groups are handled by committees, with each member studying one phase of a subject in private. In open meetings very little of value is advanced. The same principle applies to methods of study. A student can concentrate better alone than with several others in a single room. Even if no one actively interferes, more distractions are bound to arise. Students living in dormitories or rooming houses earn higher average grades than do those in fraternity houses or social clubs. The common practice of a group of students gathering together to "cram" for an examination is of doubtful value. The time spent would ordinarily be more beneficial if each worked alone without the distractions of a group.

What about the old saying, "Two heads are better than one"? Recently we have tested this with problems of three different types: the reasoning problem given on page 470, a fairly complex jigsaw puzzle, and five different algebraic and arithmetical problems. [10] Most of the latter were chosen on the grounds that they demanded thought rather than straight mathematics, so that there would be more opportunity for cooperative solution. Actually, the problem involving ranks of nobility and the jigsaw puzzle were the only ones which showed material differences between pairs working together and single workers. Even these showed differences of only about 30 per cent. If cooperative work is truly effective, it should take less than half the time spent by a single person. On the mathematical problems it was noticed that subjects frequently did not cooperate. The one with the greater aptitude tended to solve the problem largely by himself, while

the other person served as little more than onlooker. Behavior was much more genuinely cooperative in the code and puzzle problems. Another interesting point was that friends solved the code and puzzle problems about three minutes (25 per cent) more rapidly than did two strangers who were asked to work cooperatively.

TABLE 14
TIME TAKEN TO COMPLETE PROBLEM WORKING ALONE COMPARED WITH TWO WORKING TOGETHER

Problem	Alone	Together
Code solution.....	12 min. 0 sec.	9 min. 6 sec.
Jigsaw puzzle.....	17 min. 8 sec.	12 min. 36 sec.
Algebraic problems.....	4 min. 30 sec.	4 min. 39 sec.

Group maze learning was studied by Gurnee. [8] Groups of about ten persons made their successive choices by a plurality voting system, voting, for example, whether the correct turn should be left or right. Forty-two persons worked separately as a control group. The group technique permitted much more rapid learning, as is seen in the error reduction reported in Table 15.

TABLE 15
ERROR SCORES IN COLLECTIVE MAZE LEARNING

	Trial 1	Trial 2	Trial 3	Trial 4	Trial 5	Trial 6
Group	22.8	6.4	4.5	2.6	1.3	0.2
Individual	22.0	11.8	8.2	6.4	5.4	3.9

To give one further comparison: Individuals did not attain until the tenth trial the accuracy reached by the groups on the fourth trial. It must be pointed out that the groups took more time for each trial (as does any decision in a mass meeting), although the individual learners were told to concentrate on errors and to ignore the time element. The most efficient groups were those composed mostly or entirely of one sex. Might this be another angle of the distraction problem?

SUMMARY

Motivation is an extremely important topic of behavior, since it concerns itself with *why* behavior occurs. Although much of psychology describes the progress of activities, in motivation we seek to understand the forces which inspire activity. A great deal of behavior may

be accounted for on the basis of desires and drives, rather than rational decisions.

Some of the more important physiological motives are hunger, thirst, fatigue, sex, maternal behavior, the avoidance of pain, and the seeking of pleasant situations. Many of these motives increase in potency until expressed, and then tend to die down. Strong social factors, superimposed upon motives, sometimes change the nature of physiological drives.

Because of constant misuse of the term "instinct," we must be careful not to apply it to learned acts or to acts not common to all organisms. Properly, an instinct denotes an innate drive which persists as a general force even though learning and inhibition complicate and thwart it.

Much motivation is purely social in character. The force of conformity in dress, morals, and customs is strong. Publicity and attention-getting are two other strong motivating forces that can be used to encourage desirable traits.

The motivation of competition improves performance. Athletes surpass themselves; schoolboys do better in competition witnessed by friends. Knowledge of results acts as a self-motivating device, since a person compares his present with his past performances, rather than with those of other individuals.

Rewards and punishments may be in verbal form (praise and blame) or may be definitely physical (electric shocks, food, chastisement, imprisonment). In general, praise seems to produce greater motivation than blame, especially with older children and adults, but blame in turn is much more stimulating than no evaluative comment. Any such motivation should be used sparingly; otherwise it soon ceases to have stimulating value. Punishment administered for disciplinary purposes should come uniformly and immediately after the act.

Work done in a group shows special characteristics which have been given the term "Social Facilitation." There are two main trends: work is usually of greater quantity but of poorer quality than is that done in isolation.

REFERENCES

1. Anderson, H. H. Motivation of young children: further studies in success and failure, praise and blame. *Child Develpm.*, 1936, 7, 125-143.
2. Bernard, L. L. *Instinct*. New York: Henry Holt & Co., 1924.
3. Blodgett, H. C. The effect of the introduction of reward upon the maze performance of rats. *Univ. Calif. Publ. Psychol.*, 1929, 4, No. 8, 113-134.

4. Bruce, R. H. The effect of removal of reward on the maze performance of rats. *Univ. Calif. Publ. Psychol.*, 1930, **4**, No. 13, 203-214.
5. Bunch, M. E. The effect of electric shock as punishment for errors in human maze-learning. *J. comp. Psychol.*, 1928, **8**, 343-359.
6. Bunch, M. E. Certain effects of electric shock in learning a stylus maze. *J. comp. Psychol.*, 1935, **20**, 211-242.
7. Crawford, M. P. The cooperative solving of problems by young chimpanzees. *Comp. Psychol. Monogr.*, 1937, **14**, No. 2.
8. Gurnee, H. Maze learning in the collective situation. *J. Psychol.*, 1937, **3**, 437-443.
9. Hurlock, E. B. The use of group rivalry as an incentive. *J. abnorm. (soc.) Psychol.*, 1927, **22**, 278-290.
10. Husband, R. W. Cooperative versus solitary problem solution. *J. soc. Psychol.*, 1940, **11**. (In press.)
11. Leuba, C. J. A preliminary experiment to quantify an incentive and its effects. *J. abnorm. (soc.) Psychol.*, 1930, **25**, 275-288.
12. Moede, W. *Experimentelle Massenpsychologie*, 1920.
13. Murphy, G., Murphy, L. B., & Newcomb, T. M. *Experimental social psychology*. New York: Harper & Bros., 1937.
14. Sears, R. R. Initiation of the repression sequence by experienced failure. *J. exp. Psychol.*, 1937, **20**, 570-580.
15. Sullivan, E. B. Attitude in relation to learning. *Psychol. Monogr.*, 1927, **36**, No. 169.
16. Thorndike, E. L. Science and values. *Science*, 1936, **83**, No. 2140, 1-8.
17. Thorndike, E. L. What do we spend our money for? *Sci. Mon., N. Y.*, 1937, **45**, 226-232.
18. Tolman, E. C., & Honzik, C. H. Degrees of hunger, reward and non-reward, and maze learning in rats. *Univ. Calif. Publ. Psychol.*, 1930, **4**, No. 16, 241-256.
19. Triplett, N. The dynamogenic factors in pacemaking and competition. *Amer. J. Psychol.*, 1898, **2**, 507-533.
20. Vaughn, J. An experimental study of competition. *J. appl. Psychol.*, 1936, **20**, 1-15.
21. Warden, C. J., & Nissen, H. W. An experimental analysis of the obstruction method of measuring animal drives. *J. comp. Psychol.*, 1928, **8**, 325-342.
22. Wood, T. W. The effect of approbation and reproof on the mastery of nonsense syllables. *J. appl. Psychol.*, 1934, **18**, 657-664.

VIII

PRACTICAL MOTIVATION

1. Industrial Incentives

(A) **PAY.** Various schemes are used in stores and factories to motivate workers to produce more. Most familiar are the commissions paid salesmen and agents, and the piece-rate system used in many factories. It is presumed that a person will work harder if he receives pay in proportion to his efforts. The lazy and ineffectual person does not profit from the efforts of others, but is penalized for his own shortcomings. Sometimes a differential system is tried; a salesman is given a commission of 1 per cent on sales up to \$500 a week, and 2 per cent over that figure. This stimulates him to his best efforts and rewards him for making sales in excess of those necessary to cover overhead and other fixed costs.

All these are in the nature of rewards. Punishments, which in industry take the form of deductions and fines, work badly and are rarely used by thoughtful employers. Ill feeling far out of proportion to the size of the fine is caused. Attempts should be made through an interview to get at the reason behind the irregularity. If a worker becomes too slack he may have to be discharged, but petty fines raise havoc with the morale of the group. In industry we are dealing with adults, and punishment as a deterrent or incentive does not work well with mature individuals. There is no certain explanation of why this should be so, so we shall have to leave it simply as a consistent observation. Possibly children are used to being the "underdog," while adults have acquired more independence and pride.

(B) **PRIDE.** Financial incentives are by no means the only possible sources of motivation. Some illuminating facts were uncovered by Whiting Williams through firsthand study of factory workers, and

published in his books, *What's on the Worker's Mind?* and *Main-springs of Men*. [4,5] Williams dressed, acted, and lived as a common laborer while engaged in his studies, so that he would not be considered an emissary of the management. He had previously assumed, together with a great many managers, that pay is the only worry and the only source of motivation for the worker. Williams started work as a common laborer in a steel mill, and was soon offered a promotion to more skilled work. He asked how much more it paid, found it was just two cents an hour more, and accepted it rather casually. But see what happened!

From that moment it was possible to talk familiarly with the first and second helpers, those experts who peer through their colored spectacles into the changing conditions of the furnace's "bath" of hot metal up to the instant of the "tapping." For three weeks I had puzzled why these men would have nothing to do with me. Now we were suddenly become pals! But this was not all. My elevation brought honor not only inside but outside the plant. Without doubt, if my wife had lived near by, she would have received the congratulations of the wives of the unskilled laborers.¹

He had jumped a wide gap in the social scale by this apparently slight promotion. Pay could not account for more than a small fraction of the effect. This and many similar examples show that self-respect is more important than pay. We saw this general principle earlier in comparing white-collar positions and skilled labor.

Pride in work is an important matter. During the war a carpenter quit a highly paid job for one at half the pay, because he had been asked to make floating targets to be blown up by battleships, and he did not want to see his work destroyed so wantonly. Similarly, the worker who participated in the construction of Boulder Dam or the Golden Gate Bridge derives more pride from his job than the man who repairs a small highway washout. Because a man who washes skyscraper windows or operates a steam shovel attracts attention, his position is thereby enhanced.

On the negative side, certain things are especially displeasing to the worker. He is said to have three chief fears: fear of losing his job; fear of irregularity of work, and fear of not being able to take care of himself when he gets older. Other things which torment workers are lack of recognition of meritorious work, too strict and unvarying regulations, too strict and discourteous supervision, bad working conditions, and being treated as a machine rather than a human being. This latter fact applies especially to many scientific management schemes;

¹Williams, W. *What's on the worker's mind?* New York: Charles Scribner's Sons, 1920.

often a new system of work or pay is instituted without consulting or informing the workers what is going to occur or why. Most of these points boil down to self-respect and pride. Men want to feel that the work they do is worth while.

2. Practical Motivation

A man may be a fine engineer, a remarkable linguist, or a thorough scholar, but despite technical ability, if he cannot get along with people he will probably never enjoy more than mediocre success.

The essence of motivating other people is to appeal to their pride; that is, to inflate their ego. Every individual is proud of himself for one reason or another. Such pride is desirable if morale is to be sustained. Even the man who has failed at everything tries to justify and excuse himself; and regardless of how wrong his judgment may be, if his morale remains, it is still possible that he may amount to something.

Appeal may be made to a person's pride by direct flattery, by praising his past performance, by hinting that you expect good work from him, or by showing that you value his opinion. Unfavorable results are obtained from abuse, insults, and disparagements, because such tactics deflate the ego. [3]

These principles are being accepted in labor management circles, not merely for day-by-day supervision, but in forming long-term labor policies. Whiting Williams, we remember, pointed out that pay may be of less importance than self-respect. The advantages of obtaining a better paying job are not always so much in the cash itself, but in the social prestige that accrues. Self-respect is the motivating force behind moving to a better neighborhood, wearing better clothes, indulging in more expensive amusements, and even bedecking the wife with more jewels. Often material advantages are secondary. A man will prefer a raise in rank to one in pay. He likes to be called "manager," have a private office, and eat in the executive's lunchroom.

FLATTERY. Flattery is the principal way of boosting pride, and there are several ways of using it. We shall give several examples.

(1) *Use of name or title.* The newspaper editor and the astute politician recognize, take pains to remember, and use as many names as possible. Such individual recognition is especially desirable in large cities and large organizations, where person-to-person relations have diminished to the vanishing point. Calling "Oh, Jim," or "Mr. Smith, would you come here?" is far better than "Hey, you on the second machine." In writing a letter of application students will do well to find the name of the proper individual, rather than merely addressing

the letter to "Employment Manager." *Titles* set the person above others who have not earned such distinctions as doctor, professor, colonel, judge, honorable, or superintendent. Care to use such titles rather than the simple "Mr." will flatter that much more.

(2) *Suggest the importance of the other person.* Benjamin Franklin suggested the importance of the other person by putting himself under an obligation to that person. (Borrowing a book, e.g.) "He that has once done you a kindness will be more ready to do you another, than he whom you yourself have obliged." Direct flattery may be too obvious to use with a bright adult; hence one should employ more subtle ways of playing upon his self-respect. It is always flattering to ask a person's advice, since the adviser is thus placed in a position of superiority. Even if the advice is not followed, consideration has been given to the other's opinions. The intimation that a person is the only one who can perform a certain task is an immense motivating agent. Suggest to a clerk that the success of the sales drive is up to him, to an athlete that the contest hinges upon his performance, or to a general that the whole campaign depends on him—and each will outdo himself. A shrewd public speaker will take pains to praise the group, the occupation, or the city of his listeners. He will perhaps point out the necessity of that occupation in the world's work, the contribution of that society to the welfare of the city, or the outstanding civic achievements of the city in which he is speaking. Ignoring a person's presence or his efforts is discouraging to that individual. Wise executives make it a point to nod or say a word to workers or clerks as they pass by.

(3) *Listening* is an indirect form of flattery. Many conversations turn into contests to see whose interests and experiences shall be discussed, and each person leaves with the impression that the others are dull and willful. It is well to remember that you can learn nothing from others as long as you are talking yourself. By listening and occasionally leading the other person on by judicious questions, a friendly attitude can be built up. If the man on whom you desire to make an impression makes a hobby of baseball, fishing, stamp collecting, photography, dogs, travel, or music, by all means turn the conversation to that field. Men have actually spent hours preparing for an interview, reading articles or books on their prospect's hobby. When the time comes to turn to strict business, the person interviewed will be more favorably disposed.

(4) *Modesty* has the advantage of lessening the gap between the leader and the other person. Superiority or self-importance in a person implies that others are inferior, and arouses antagonism. A person who is sure of himself does not need to put himself on a pedestal to gain

situations in which motivation is not possible. We might illustrate the point by an extremely hypothetical example. It is doubtful if a wealthy self-made businessman could be induced to donate a million dollars to finance a staff of men to count all the "alphas" in the original Greek of Homer's *Iliad*.

In general, motivation depends upon the individual's own initiative, his own desire for the object or the activity. Externally applied motives are insufficient of themselves. When a parent tries to motivate a school child by saying, "You want to get better grades," no incentive is furnished the child. Unless the pupil desires higher grades himself, there will be no improvement. Likewise, an adult cannot be motivated to wear better clothes unless he sees for himself that his business and social success will be aided by such a change. As long as the desire for improvement is in the mind only of a third person, nothing will happen.

The following paragraphs contain a number of reasons why motivation may not succeed.

(A) SITUATION DOES NOT APPEAL TO THAT INDIVIDUAL. The difficulty in motivating often lies in the situation rather than in the individual. The millionaire who could not be persuaded to donate to Greek research might succumb to a committee who asked him to found a school of business. He is more interested in that particular field of education than in Greek literature. All of us are at times besieged by friends who want us to join amusement circles: golf clubs, tennis clubs, bridge groups, fishing expeditions. They wonder why we do not share their enthusiasm. Actually we have other interests. We may have no desire to play golf, not that it is a poor sport, but because during the summer months we prefer to play tennis or to swim. Hence such incentives are not taken up by ourselves, but remain within the third person.

Failure to recognize this factor explains many of the problems of higher education. Parents, professors, and administrators try to make certain students live more nearly up to the limits of their capacities. It may not have occurred to them perhaps that some individuals are not suited for the traditional educational sequence, and hence will never do well. It is unfortunate that social pressures are such that the great majority are expected to follow the one single line from grade school through college. This is not the place to estimate how many individuals are better suited for other types of training or what those forms of training should be.

As a practical matter, motivation should be designed to fit in with the interests of the individual. Ice cream may interest a man, but a bird would prefer a nice juicy worm. A boy may not respond to abstract motivation by eating his spinach, but he may ask for a second

helping after seeing a testimonial by a famous athlete. The advertisers thus score a bull's-eye in his interests; the parents do not.

(B) **EACH PERSON MAY REQUIRE DIFFERENT MOTIVATION.** Clever salesmen do not use the same series of arguments on each customer. Advertisers use different appeals to men, women, travelers, parents, college students. A football player said about his coach, "He treats each one of us differently." This implied that the same motivational tactics were not employed with all players.

(C) **CONFLICTS OF MOTIVES.** When two motives are present, one triumphs and the other is not expressed. Many such conflicts are financial in basis. A person often wonders which of two possibilities is wiser. Should I buy a new spring suit and sacrifice that vacation trip? Should I spend my vacation money to have my house painted? Should I attend a formal dance or stay home and buy a new pair of shoes with the same money? Investment of time as well as money may be considered. A man may not wish to study the rules of bridge enough to become an expert player; he decides that he is content to play an average game. He may prefer to play tennis rather than golf because it takes only half as long to get the same amount of exercise.

(D) **REWARD NOT IMMEDIATE ENOUGH.** Another source of failure in education is that the fruits of labor are not close enough to furnish sufficient motivation. It is difficult to persuade a growing boy that extra study in the fourth grade will make him wealthier in middle age. It is difficult to persuade an employer to hire you without experience, even though your services will be of added value after the training period is over. The same principle holds true for punishment. A doctor may warn you that continuance of a certain habit will have its effects in later years, but the possible consequences are so remote that the full significance of his warning is not appreciated.

(E) **CONFLICTS WITH PREVIOUS HABITS.** Many failures of motivation are due to the fact that the suggested action is at variance with established habits. Pet economies often have their basis in past necessities. A young businessman said that he almost never took taxis despite their cheapness in his city, because when he was a boy he had little money and taxis were especially expensive. Therefore, hiring a cab had always seemed a wild extravagance to him. Habits are often used to justify refusals: "I can't play golf on Sunday; I always drive out into the country"; "I don't want to eat any chop suey; I never eat foreign foods."

We shall consider here mental and emotional habits, as well as those that involve definite physical action. Marital difficulties sometimes arise from inability to get rid of certain taboos about sex. These taboos

may have served a purpose earlier by preventing improper behavior. Some people have difficulty in forming friendships with those of other races or religions because of early experiences with members of such groups. Airplane companies have difficulty in persuading older people to travel by air, because of attitudes formed in the early days of flying. Figures proving that it is several times more dangerous to travel in one's own automobile than by commercial air transport fail to convince some of these older people, because the emotional factor is stronger than the intellectual.

(F) UNPLEASANT PAST EXPERIENCE. When a person has had tough luck with an automobile, it is extremely difficult to persuade him to buy another of the same make. He has soured on the company and does not want another of their products, even though he may realize that any car manufacturer now and then turns out a "lemon." A person will avoid a certain food after becoming ill from eating it. In some cases he is even unable to look at or think about that item of diet without nausea. An unpleasant experience, such as stopping at a poor hotel or being cheated by a good one, may so affect him that he will never desire to visit that city again.

(G) INABILITY TO ATTAIN GOAL. A person who cannot quite reach the goal he has set, or his family has set for him, may entirely lose interest and stop efforts in that direction. In fact, some cases of insanity are attributed to this conflict between reality and fanciful goals. The man who wants to become a millionaire is not satisfied with a modest income, goes insane, and actually becomes in his wishful thinking a wealthy and powerful man. A similar, but less striking, example is of the man who loses a job, tries hard to get another, fails for a while, and finally allows his efforts to dwindle entirely. He has completely lost his motivation to occupy a normal place in economic society.

(H) INTERESTS MAY HAVE CHANGED. When we decline to do something, our friends may retaliate: "Well, last year you were always ready to go with us." Technically, it did not take much to motivate us then, but now motivation is much more difficult. Our liking for various foods may rise and wane. Formerly we liked coconut, say, but now we refuse anything flavored with it. Changes of interests with age are well known, and undoubtedly have a physiological basis. As we grow older we gradually lose interest in violent sports, in dancing, and in strenuous vacation trips. Another sign of maturity is less dependency upon parents and immediate family and more desire to spend time with friends of either sex.

(I) VACILLATION. Some individuals are chronically unable to arrive at a rapid decision. They express themselves somewhat as fol-

lows: "I just don't know what to say." "I suppose I should, but . . ." They may lean one way and another, reversing their decision every few minutes. Protracted vacillation may ultimately lead to no action at all. A college student debates with himself after dinner whether he should get a date or go to a movie alone. He keeps pondering until it is after nine o'clock and too late to do either. Or there may be only a single variable: whether to go to the movies or not, or whether to buy a new pair of shoes or not.

4. Loss of Motivation

(A) DESCRIPTION. Occasionally a person loses all motivation. Nothing seems to interest or amuse him. As Myerson, [2] who has written a fascinating little book on this topic, says :

To be really alive is to have lust, desire, enthusiasm and ideals; is to enjoy the things of the flesh and the things of the spirit in a hearty, wholesome fashion; is to seek eagerly and to drink deeply. To be otherwise is to be dead, even though one's heart beats regularly and rhythmically, even though one walks amongst living men like one of them.⁴

We cite at some length a case which gives a better concrete example than can any amount of abstract description.

Ex-service man speaks.

"I don't know what has come over me," he told me. "I went to France with my unit, an eager, strong young fellow. I liked everything in the world. I could eat any time, any place and any old thing—and sleep! When I hit the hay, I was off the second I touched the pillow and the next morning I would wake up like a two-year-old ready for the pasture, I could enjoy things so—people, good times, girls, music and books, and even the grind of hikes and drill was good to me. Every day was new, unlike any other day. I was full of pep and ginger and the joy of just being alive. . . .

"I do not know what it was: perhaps the 'flu' I got in November, 1918, just after the Armistice; perhaps it was the dead waiting to go home. I thought America and home would be so pleasant after the slaughter. I came back and got a job with my old concern, but something inside me was dead and got deader every day. My friends came up to greet me and you could see they were real glad to shake my hand and I couldn't feel anything at all. It seemed to me I smiled and nodded like a mechanical doll with sawdust for insides. Food seemed flat and tasteless, everything was without salt, and it was so hard to swallow it that I gagged as if it were so much cloth. I lost my appetite, and yet I would get faint with hunger. I tried to drink to see if a little booze would stir up my appetite, but it had no effect except to make me so dizzy I could not stand. Sleep had gone entirely. I never got

⁴Myerson, A. *When life loses its zest*. Boston: Little, Brown & Co., 1925.

drowsy any more, never caught myself nodding. When I went to bed, though I ached with weariness, a restlessness came over me that was maddening. No position seemed comfortable, for there was a twitching in my very blood, it seemed. Every noise in the house was like thunder, and I, who slept under the roar of German guns, could not sleep in the quiet of my suburban home. Every task loomed a mountain high—energy, pep, everything seemed gone. Venus, if she came before me dressed in silks and satins, or clad like ‘September Morn,’ would mean nothing to me. And the girls meant a lot to me before that.

“The worst, almost, is the awful restlessness. I go to a movie, and before I know it the place is full of intolerable noises; a whispering couple make me long to kill them, though a companion scarcely notices them. Everything distracts me; the scraping of feet is a personal insult; a loud laugh like a blow. I cannot sit still; I become conscious of all my body, even to my insides, and I am full of queer numbness and fleeting pin pricks. Then I bolt for the door, my heart beating fast, and a suffocating fear upon me. The noise of the city, the presence of a crowd, make my heart jump out of my chest into my throat, and yet within this excitement there is always that dead feeling inside of me. I often say to myself, ‘I would swap places with any “dago” ditch digger, eating his sandwiches at noon with appetite and satisfaction, sleeping at night, singing at his work during the day and loving himself and his fellows.’ . . .

“I wander about, for I can no longer work, like a ghost in a world of living men. When you can’t eat or sleep or work, when you can’t be hungry or passionate, when you jump like a deer at any noise, things commence to go wrong with the whole world, and you commence to question, question, question—why is this, why is that? There is no reality and no meaning to anything. I look at my face in the glass and I think of the ancient Greek cynic who said man was a forked radish with a grotesquely curved top. The rolling eyes; how queer the immovable piece of protruding flesh with two holes—the nose; the clamping teeth in a hole of a mouth. I hate to look at myself or anybody else. Even a pretty girl is a curved radish with a fluffy-haired top. A questioning mania comes over me—a circle of questions that no wise man could answer and only a fool would ask. And I can’t make up my mind to anything. If I say ‘yes,’ all the arguments for ‘no’ crowd into my mind, and then ‘yes’ and ‘no’ go at it till I grow dizzy and try to think of something else. But how can you think of something else; how can you control your thoughts? When I was well it seemed to me the easiest thing to do. If a thing was unpleasant to think about, you shivered a little, shook your head, and your mind was off to pleasant things. But now my mind goes around in a circle, and I stand aside as if my mind and I were two different things.

“Am I sad, melancholy? That’s the funniest part of it to me. When I was in France, a doughboy in my platoon went ‘nuts.’ He started in by being blue and became more and more so, until he sat in a corner of his

tent all day, refusing to eat or sleep, and if you talked to him he would slowly look at you with a face like his own funeral and whisper very slowly that 'he was damned, no good, ought to be killed' and truck like that. I am not sad at all. I don't think I have done wrong or that I am to blame for anything. I want nothing except that I want to *want* again, if you understand that, and I want to eat, drink and be merry. I want to sleep at night; I want to feel pep and energy and to stop looking at myself and the world, to stop asking 'Why, why, why?' all the time."⁵

Some people are more susceptible than others to such loss of pleasure. They become discouraged by slight reversals or minor illnesses and continually need someone to encourage and prod them. Others have a lot of available energy and receive adversity with a smile and redoubled efforts.

(B) DEVELOPMENT OF LOSS OF MOTIVATION. Every person normally likes excitement. A routine life is monotonous and boring. So we have parties and picnics, go to athletic contests and circuses, travel and enjoy all kinds of divertimento. College graduates seek work in large cities where they expect to find more glamour than their home town affords. So far, so good. No one criticizes a person for the possession of healthy desires, but excitement tends to be a habit-forming drug demanding greater and greater doses. An occasional drink turns into a desire for cocktails before every dinner and highballs every night. Some people cannot spend a quiet evening at home, but must be always on the go. Fifty miles an hour demands sixty; ordinary foods give way to unusual and highly spiced diets.

Although such extremes may be criticized from a moral standpoint, the individual still does derive pleasure. But there comes a time when jaded tastes cannot be satisfied. Such an individual is tired of eating, drinking, sex, amusements, seeing places. He develops a "what's the use?" attitude.

(C) CAUSES OF LOSS OF MOTIVATION. Apart from habituation—pleasurable activities which have become routine—there are several other causes of loss of zest in life. (1) *Age* causes a diminution of various pleasures. The aging person does not plunge into a meal with so much avidity, nor do simple foods seem so satisfactory. A stage in this decline occurs when people become finicky about their eating surroundings, demand absolute cleanliness of dishes and linen, careful handling of food, and restrained conversation on the part of their tablemates. If a person can eat from a tin plate, with the meat a bit charred, and not be bothered by rough conversation, he is no candidate for this phase of neuroticism.

⁵Myerson. *When life loses its zest, op. cit.*, p. 7.

(2) *Sleeplessness* is one of the earliest symptoms of loss of motivation. Sleep is a normal, healthy, animal function. It should be welcomed for the recovery of energies expended during the day. The more common evidences of disturbance are inability to fall asleep for long periods, brooding, waking up frequently during the night, not being refreshed in the morning. Physical work, the cruder the better, such as mowing the lawn or playing a strenuous game, will help to alleviate these symptoms. There is a mental as well as a physical side to recovery. A man who is nervously exhausted may go on a camping trip and recover his appetite and sleeping ability long before it would seem physiologically reasonable. His motivational balance has been changed.

(3) *Physical illness* is another source. Following a lengthy illness a person's energy is reduced. It is difficult to do things because he does not have the strength to meet problems as they come up. When a person cuts short the period of convalescence and goes back to work and to social affairs, he is likely to lack motivation, to feel "let down." Myerson suggests that before resuming his duties he should have full appetite and enjoy his food, sleep well and awake refreshed, and be interested in and eager for his work. The author, for example, when rather tired and on a vacation, knows he is ready to resume work when he finds himself eager to return to lecturing and writing.

(4) *Too much work* becomes monotonous, a drag, and no longer a source of pride or satisfaction. This may result from too continuous work, the worry associated with it, or failure to progress.

(5) *Destruction of hopes and ambitions*. When a man finds that he has not the ability to attain his coveted goal, or that another person of equal ability is chosen for an important position, there is small wonder that he loses enthusiasm and drive. Myerson points out that our democratic society, which boasts that a boy from the poorest home may rise to the highest position, provides a highly competitive system that is conducive to individual breakdown. On the other hand, the caste system in some European and Asiatic countries fits each person into a groove which he accepts with little friction. The individual in those countries can have no vocational, financial, or social ambitions that are beyond reasonable expectation of attainment.

(D) CURING LOSS OF MOTIVATION. (1) In mild cases, just plain *determination* may suffice. By way of minor analogy, we might cite the common experience of writing letters. We keep putting them aside with weak excuses, but after we actually start to write we really enjoy it.

(2) *Build the health up*. A sound mind demands a sound body, and when in good health a person can better enjoy his work and other

activities. Exercise, sleep, and moderation will serve to bring back the appetite, and much of the battle will be won.

(3) *Change of activities.* We have already cited the example of the camping trip. I know from my past experience that going to the mountains, camping out, cooking simple meals, hiking a number of miles a day, taking swims in cold lakes, going to bed at nine and getting up at six, will restore me to enthusiasm and zest more quickly than any other form of vacation. The greater the change from customary routine the better. I go without shaving, wear old clothes, read little and then only the cheapest magazines, ignore daily papers. I do not necessarily recommend such a vacation for everyone. Each of us has different tastes. But such a routine as I have suggested works with many people. In line with our general principles, it might be suggested that the more social type of vacation will not furnish the best possible rest. Many persons travel several hundred miles a day, stop at luxurious hotels, eat fancy foods, dance until late hours, rush about seeing the sights, and do everything but ease down from the strain of daily working life. Students sometimes say, half in jest, that they have returned to college from the summer's vacation to rest. There is more than jest in such remarks. It would appear that hobbies involving relaxation and freedom from worry are best. Fishing and hunting are two low-pressure activities which provide distraction from worries, but not at the cost of new strains.

(4) *Setting up new goals.* Loss of motivation is reported frequently among people who have too little to do: middle-aged wealthy women and the children of rich families. They have so much money that there is no necessity of their acquiring or maintaining any competence, and they even have servants to do their routine work. The millionaire often finds his business worries multiplied, but as he grows richer his wife has progressively less and less to do. Some individuals have found their zest for life increased when they lost their money. Most people appreciate the pleasures they have earned by their own efforts more than those made possible by hereditary wealth. (I am not moralizing or speaking of character development; I am concerned here only with the individual's own enjoyment of life.)

(E) CONCLUSIONS. We notice throughout all this discussion that Myerson believes in strong expression and keen enjoyment of the basic motives in life: eating, drinking, sleeping, working, getting ahead. He discourages the ascetic urges of some people, rather sarcastically suggesting that they undoubtedly lack motivation themselves, and so demand that others drop to their level. At the same time, he does not suggest unlimited freedom of expression; development of will power is a

necessary part of the personality. One must learn to stand up under disappointments and to fight back. But a rollicking rogue such as Falstaff or Henry VIII is far happier and better adjusted to society than is a highly inhibited, ultrarefined, "the-cares-of-the-world-are-on-my-shoulders" individual.

SUMMARY

In motivating other people, the general principle is to boost their pride in themselves and to avoid deflating the ego in any way. Constructive suggestions are to use the person's name or title, to indicate his importance by asking his judgment or by some other subtle flattery, to avoid placing him in an unfavorable light by undue criticism, and to avoid the use of pointed humor.

It is not possible to motivate everyone to do everything. Some individuals will not respond to certain types of motivation. To be adequate a motive must be taken up by the individual himself. As long as it remains solely the desire of someone else, it will not constitute a motivating force.

Failures of motivation occur when the situation does not appeal to the person concerned, when the particular motive is not appropriate, when there is a conflict between motives, when the reward is not immediate enough, when there are conflicts with previous habits, when the goal is not within reach, when interests have changed, and when it is not possible to arrive at a rapid decision.

Sometimes a person loses all motivation. He is no longer interested in (motivated by) food, drink, sleep, work, or his customary amusements. This loss may be alleviated by building up the health, changing activities, finding new interests and goals.

REFERENCES

1. Guthrie, E. R. *The psychology of human conflict*. New York: Harper & Bros., 1938. Chapters VIII, XXIII, XXIV, XXV, XXVI.
2. Myerson, A. *When life loses its zest*. Boston: Little, Brown & Co., 1925.
3. Webb, E. T., & Morgan, J. J. B. *Strategy in handling people*. New York: Garden City Publishing Co., 1930.
4. Williams, W. *Mainsprings of men*. New York: Charles Scribner's Sons, 1925.
5. Williams, W. *What's on the worker's mind?* New York: Charles Scribner's Sons, 1920.

IX

NATURE OF EMOTIONS

1. Emotional Behavior in General

Think of the number of times daily we manifest emotional behavior: laughter, annoyance, anger, fear, love, friendship, surprise, relief, excitement, tension, dread, anticipation, disgust, shame. Some of these emotions are pleasant; others are unpleasant. Of some we may desire to rid ourselves; others we deliberately seek and encourage.

Emotional behavior may be contrasted with rational behavior in several ways. The most apparent difference is that it is a disturbed state, in contrast with calm, calculated, and planned behavior. Being thus disturbed, behavior becomes disorganized and sometimes loses appropriateness. A person making a speech may lose a word, become panic-stricken, and be unable to extemporize; whereas he would have no such difficulty if talking with a single friend. A minor distraction may so interrupt intellectual work that it is impossible to resume the thread of thought for a long time.

Another contrast between emotional and rational behavior is in the physiological sphere. Emotion produces a diffuse or mass response. In flight (fear) or fighting (anger) the whole body is concerned. Even if no muscular movement is made, there may be sensations from head to foot. Muscles become tense, the face flushes or pales, the viscera of an arithmetic problem is achieved while the body is relatively motionless.

Darwin, proponent of the theory of evolution, suggested that emotion become upset, the knees feel weak, and the toes cold. Intellectual activity, by contrast, involves specific and minute movements. Reading, for instance, demands only small hand and eye movements; the solution of problems originated because of their survival value. Fear and anger in-

crease strength to flee or fight by releasing inhibitions which normally restrain people from exerting themselves to the utmost. In animals, preliminary manifestations of anger, such as growling, showing the teeth, and tense stalking movements, often frighten other animals away.

In our civilization, however, a great many emotional manifestations are no longer desirable, and they may even lead to unpleasant consequences. People lose their jobs or suffer social disgrace because they are unable to control their tempers, soldiers are court-martialed because they succumb to fear and run away from danger, people are killed in panics caused by theater fires, lynchings and economic or social reprisals follow intense excitement. Such behavior is termed infantile, because it represents a less mature and less inhibited form of action. It is a regression to behavior which the individual or society should have outgrown.

Approach to the study of emotions follows two lines: (1) behavioral and (2) introspective. We may prefer for scientific reasons to watch behavior in the forms of skeletal movements and physiological responses, but in the case of emotions these do not tell the whole story. Much emotion is internal and can be studied only by inducing the subject to tell us what he is experiencing. On opening night an actor may do a splendid job, but confess afterward that he was thoroughly frightened during the first few minutes. We may be exceedingly bored at a social affair, but our good manners force us to keep our feelings to ourselves, and we try to look happy and interested. A boxer may be in distress, but he tries to conceal the fact and pretend that he has not been hurt at all. The poker face is well known as an attempt to separate facial expression from actual internal feelings. We may be suffering extreme pain in the dentist's chair, but we try to remain motionless and expressionless. Because of these conscious restraints upon emotion it becomes necessary to utilize the introspective approach to the study of emotions.

2. Neural Control of Emotions

(A) **CEREBRUM.** Does the cerebrum play any part in emotions, or is emotional control entirely vested in the lower centers? Human evidence is naturally limited, but a number of studies have been conducted on dogs and cats. These show that removal of the cerebral cortex leaves the animals still capable of displaying rage or anger, although the expressions are sometimes called sham emotions, since regardless of overt expression the mental state is uncertain. (In the human being, removal of both hemispheres is followed by total and permanent unconscious-

ness, if not death, so discussion of emotional states would be irrelevant.) At any rate, the following types of behavior have been reported in dogs and cats: a dog snarls and growls when its back is gently scratched; a fly on the nose leads to a fit of activity closely resembling rage; light pinching of a cat's tail evokes hissing and biting, arching of back and clawing, panting, erection of hair, dilatation of pupils, sweating, increase of arterial blood pressure, and discharge of adrenalin, just as in the intact animal.

Some evidence suggests that cerebral destruction may actually heighten emotional expression. It is probable that the cerebral cortex acts as a brake, or inhibiting agent. Following certain disorders, a slight stimulation is sufficient to arouse excessive feelings and sensations. We have already seen (page 80) evidence parallel to this, in that destruction of the prefrontal area causes personality changes, such as loss of modesty and excessive bragging. Normally such tendencies are restrained.

(B) **THALAMUS.** This is a lower brain center within the central nervous system, which acts both in emotions and as a sensory relay station. Destruction in the thalamic area often results in emotional disturbances, although clinical evidence varies regarding human beings. In some cases positive evidence of emotional disturbance occurs; in others thalamic injury is not followed by any emotional upset, and in a few cases post-mortem investigations have disclosed no thalamic lesion. Some patients have reported that emotional experiences were tremendously heightened: tickling, pleasant music, and other sensory stimuli produced far more than normal excitement. After thalamic lesion, one musician could no longer listen to symphony music because it caused uncomfortable, acute sensations in the right half of the body. On the other hand, sometimes there is complete emotional apathy. One case cites a businessman who had a thalamic disorder, so that he felt no unhappiness upon leaving his wife for a business trip. We presume that he had formerly possessed such feelings!

(C) **AUTONOMIC NERVOUS SYSTEM.** Many of the feelings associated with emotional experiences are located in the visceral organs, especially in the lower abdominal region. Let us trace their nervous connections.

The term "autonomic" literally means "independent." In political science it refers to a group or body which is responsible to no other. In this case the term means freedom from voluntary control by the central nervous system. The principal organs governed by it are the heart and blood vessels, lungs and air passages, stomach, intestines, liver and pancreas, eliminative organs, and reproductive organs.

Most of the organs named above have two characteristics. First, they have smooth muscle fibers (like the skin of a sausage). Voluntary, or skeletal, muscles are striped; biceps or calf muscles are stringy and composed of parallel fibers. Much of the structure of these skeletal muscles can be detected only under a microscope. A second characteristic, more important from a functional standpoint, is that these organs operate in general unconsciously and involuntarily. Obviously, no one can regulate his heart or digestion as he can wiggle his fingers or toes. A few of the organs which are normally under control of the autonomic system can be regulated voluntarily. We may not pay attention to our breathing for weeks; yet we can hold our breath underwater or when we play a wind instrument. Although some people have the ability to weep at will, it is impossible to avoid a flow of tears if a foreign substance gets into the eye.

The autonomic system has "dual control," in that each organ is supplied with two sets of nerves, antagonistic to each other. The names given these two systems are the *sympathetic* and the *parasympathetic*. Normally the two systems are in balance with each other, and keep our breathing, heart action, and digestion proceeding at a normal pace. But in the stress of emotion, the sympathetic division gets the upper hand, and our processes are speeded up. It is the sympathetic division of the autonomic nervous system, then, that we need to bear in mind principally as we study emotional behavior. As an example of the way in which the two systems work, the normal heart rate is 70 to 80 beats a minute, but severing of the parasympathetic system has been known to raise it to as high as 300, while severing of the sympathetic may lower it to 30. Since intense emotion rarely raises the heartbeat to much over 100, it is clear that the parasympathetic is never totally inhibited; it merely has a lesser share in control than ordinarily.

3. Physiological Changes in Emotion

Many of the physiological changes occurring during emotion are known to us through our own experience. Additional laboratory evidence has been obtained with regard to certain effects.

(A) HEART RATE. Heart rate becomes more rapid and blood pressure rises. We are most conscious of this while in a position of expectancy, say dread, as when waiting our turn to give a speech or to have a tooth pulled. If we are running or fighting, other movements prevent our noticing heart changes. Heart attacks often occur during exciting football or baseball games, sometimes even to persons listening to the radio. After a heavyweight championship prize fight the morning papers reported that a man had died in one of the fighters' dressing

rooms, several had been carried from the arena, and several more had died at their radios. Likewise, other forms of excitement prove too much for a weak heart: a sudden fright, hearing of the death of a friend, finding one's house on fire, a mystery play.

———, Michigan. Mrs. ———, 23 years old, wife of a well-to-do farmer, died of excitement late last night as fire destroyed their five buildings, as well as poultry and live stock worth \$10,000.

(B) BREATHING. Breathing becomes more rapid and often spasmodic. This is especially true in surprise. The breath will be taken in suddenly, even if the stimulus comes when the person is exhaling. The normal rhythm of breathing may be altered for several minutes. In excitement the intake of breath is rapid and jerky, in contrast to normal, slow, steady inhalation.

(C) PERSPIRATION. Whether general or localized, perspiration is a frequent accompaniment of sustained emotion, especially tension and excitement. During examinations students are frequently seen wiping their foreheads and hands. It is also quite common for spectators at an exciting athletic contest to find themselves soaked with perspiration. A student described attending a basketball game, which was to settle the championship.

The pavilion was rather chilly when I arrived, so I kept my overcoat on. When the game started, I slipped my top coat off, next I unbuttoned my suitcoat and vest, and finally, when the game ended, I found that I had unbuttoned my shirt collar and that my undershirt was moist.

(D) SALIVARY FLUID. Salivary fluid and digestive juices cease flowing during excitement. Intense excitement and tension sometimes even bring on acute nausea. Digestion in cats ceases if a dog is placed before them and anger is aroused. Dryness of the mouth is common among speakers and athletes, particularly beginners. For digestion's sake it is strongly urged that families refrain from quarreling at the table. Businessmen will be better off if they lunch in quiet, leisurely places.

(E) ADRENALIN. The output of adrenalin is increased. The adrenal glands are located above each kidney, although they have no relation to elimination. Adrenalin produces a number of effects by itself, and also acts on the liver, which in turn releases blood sugar.

The more important effects of adrenalin are:

1. Stronger and more rapid heart contractions.
2. Rise in blood pressure, through contraction of the arterioles, which promotes removal of waste products.

3. Dilation of pupil of eye.
4. More pronounced contraction of skeletal muscles, with more rapid and complete relaxation.
5. Increased sugar content of urine, which may persist several days.
6. Opening of air passages in lungs.
7. Rapid clotting of blood.
8. Erection of hair, along backbone of dogs.

Thus, it is seen that adrenalin is very valuable for emergency purposes, such as fighting or fleeing. Strength is artificially raised, onset of fatigue is delayed, circulation of air and blood is aided, and the weakening effects of prolonged exertion or loss of blood from slight wounds are avoided. A father once made his son furiously angry before sending him out to beat the rugs, just to ensure that a thorough job would be done. In most daily situations the adrenals are not called upon, and often when they do function the resultant behavior is socially harmful rather than desirable. Possibly those who benefit most from adrenalin output are explorers, mountain climbers, and athletes, who perform difficult physical feats under stress.

4. "Lie Detection"—A Practical Use of Emotional Measures

Modern crime detection has in many instances made use of some of the psychological concomitants of emotions which we have been discussing. One of the most useful methods is to measure blood pressure, heart rate, and breathing. [21] A suspect who claims innocence is placed in an apparatus which measures heart action from the artery on the inner side of the upper arm, and records breathing from a tube fastened around the chest. He is then asked a series of questions, some neutral and some having to do with the crime. Supposedly the guilty person will become upset and give himself away by irregularities in heart and respiratory action. The innocent person will be cleared, since one question will stir up no greater emotional response than another in him.

Blood pressure is an especially sensitive index of emotional tension. Often a suspect denies everything, yet certain questions produce a physiological response. The series may be repeated and show similar results. In such a case the verbal reply may be virtually ignored. It is interesting to note that frequently a guilty person will realize that he is up against something he cannot beat, and will confess right in the midst of questioning. After confession tension will have disappeared and blood pressure will decrease. In one instance systolic readings (pressure at the crest of the pulse wave) were 155-150-158-151-156-

149-155-152 during the deception test, and when the same questions were repeated after confession the pressure dropped to 125-130-124-128-122-126-119-116.

A murder case in a large city was solved solely by use of emotional measures. A man's wife disappeared and he was suspected, but no proof existed because the body could not be found. He was placed in the apparatus and a map of the city was spread out in front of him. It was noticed that every time the pencil was pointed toward a certain suburb the suspect's blood pressure rose. So by using a method similar to the game we played as children where we called "warmer" if the seeker came near the hidden object, the location of the body was centered to within a few rods of the actual place where it was eventually found.

Two crucial questions frequently come up with regard to the accuracy of this device. First, could not the guilty person control his emotions and deceive the apparatus and the examiner? Apparently not. The reader can find the reason for himself if he reviews his knowledge of the nervous control of emotions. This lies in the autonomic nervous system, which is unconscious and involuntary and hence out of voluntary control. We may not even realize that changes are occurring. A guilty person, at the moment merely a suspect, might answer questions calmly and keep a poker face, but his visceral reactions would be a giveaway. In a case of petty thievery on a college campus, a medical student was found guilty by means of this apparatus, in spite of the fact that he had used the same instruments many times in laboratory work and boasted that if he did happen to be the guilty person he could control his responses.

The instrument appears to be fairly sensitive. A common method to convince a skeptical judge is to ask him to select one card of ten and keep his decision to himself. He is then shown each in turn and told to answer "no" when asked if it was the correct card. Blood pressure will gradually rise until the correct card has been shown, and then will sink to and remain on the subject's usual level. Tension has been relieved, just as after a confession. This situation is obviously mild enough, and the "guilt" is only academic, yet it appears clearly in nearly every case. The response would, of course, be much more violent in a crucial situation.

A second common question is whether an innocent person might not show excitement if arrested and questioned. Naturally anyone who was suspected would be bound to be tense, but his disturbance would remain on a constant level. The guilty person, on the other hand, would show heightened response to critical questions, which ideally would be framed carefully to deal with material known only to the guilty in-

dividual. Since eventually guilt or innocence must rest with the suspect, it is well-nigh impossible to estimate with certainty the accuracy of this device. It is claimed, however, to be in the neighborhood of 90 per cent.

The verbal responses of the suspects may also furnish supplementary evidence, although descriptions by the experts who use the instrument suggest that blood pressure evidence gives by far the best single cue. (1) Wide differences in the time taken to reply to various questions suggest that the conscience is not clear. (2) Peculiar responses, such as repeating the stimulus word, repeating the last response, farfetched associations, illogical associations, and in an extreme case failure to answer at all, all give evidence that something is being covered up. (3) Confusion, averted gaze, blushing, wiping the forehead, muscular tension, and fidgeting sometimes give evidence where the actual verbal reply may indicate little.

A similar technique has been employed by Luria in Russia. [16] In addition to verbal stimuli and physiological measures he tested coordination between central and motor responses. The subject is instructed to press a receiver (like a telegraph key) simultaneously with his verbal reply. Where an emotional effect is present, as in guilt, the subject loses his ability to produce the coordinated movements which characterize the perfectly composed person. As expected, word-reaction time is nearly a second longer on the average (2.3 as compared with 1.4), and in certain instances will be as long as five to ten seconds. After tension has been removed following confession, normal coordination is reestablished and reactions become regular and uniform.

5. Psychological and Physiological Aspects of Emotions

Psychologists have long disputed the exact cause of emotional states. Does the mental state come first and cause the visceral upset? Or is the true emotion founded upon the visceral responses, which then produce the conscious feelings of emotion? If the latter theory were correct, an organism would feel no emotion if it had no visceral sensations.

A few pathological cases involving nervous disorder fail to show definite correlation between loss of nervous connections and loss of emotions. A case is reported of a woman who suffered a broken neck and lost most of her bodily sensations, but who retained all emotions with undiminished strength and unaltered quality. [7] Even when the conscious emotional content is normal, organic disturbances may give rise to bizarre and inappropriate motor responses. Illustrative are those cases of pathological laughing in which the patients burst into uncon-

trollable mirth in response to painful or unpleasant stimuli, and those of pathological crying in which pleasant states or humorous anecdotes elicit copious tears. In such cases the patients actually suffer distress over the fact that their outward emotional responses are contradictory to the way they feel. [1, 4]

Some clever experimentation has been conducted by Cannon at Harvard [6] and by Sherrington [23] at Oxford to test this point. They (working independently) cut the autonomic nerves of dogs in such a way that nervous connections between the cerebrum and viscera were interrupted. But anger and pleasure seemed, from behavioral evidence, to be as keen as ever. The dogs growled, barked, bared their teeth, their hair stood erect, and all the other usual signs of violent emotion appeared when cats were brought into their presence. To rule out the possibilities that these responses might have been learned, Cannon operated on young puppies who had never seen a cat, yet the same emotional behavior was displayed. Of course, we cannot say for certain that the dogs felt any emotion, but to deny it seems far less appropriate than to assume it.

On the other hand, such evidence suggests only that physiological accompaniments are necessary for complete emotional feelings, and not that they tell the whole story. One point is that the physical reaction may occur after the response has been made. We all have had the experience of having an automobile suddenly shoot out from a side road or a parking place, of jerking our car out of the way, and then perhaps several seconds later feeling a sinking sensation. The actual response has been so sudden and violent that the driver was thoroughly startled; yet the feeling of emotion has been delayed. Another point is that it is possible to work up visceral responses by thinking about a situation. I once visited the Grand Canyon in Arizona and stood on the edge of a 4,000-foot cliff without especial excitement, but late that evening, upon recalling it, I was truly terrified. A person may become "fighting mad" when a friend tells about being cheated, insulted, or treated unfairly.

Another line of attack is to see whether emotions may be built up synthetically by duplicating their physiological accompaniments. Several experimenters have tried injections of adrenalin. [14, 18] The results are largely negative. Subjects are somewhat stirred up, as if they were going to have an emotion or were expecting something exciting to happen. Possibly the feeling is somewhat like that of a student who receives a letter asking him to see the dean immediately, but does not know quite what business may be brought up.

Subjects reported that they felt not a real, but a "cold" emotion. At

best, they experienced an emotional state without the presence of any object or reason. Here are a few reports from subjects.

"Feel as though I had had a big scare, not fright but like a reaction after fright."

"Feel as I do either before an event in which I am to take an active part—such as a public appearance or athletic competition, or before some great joy which I am anticipating."

"I seem oppressed with a vague fear of something—feeling much the same as when I've lain awake all night, frightened that Bill might die."

"Felt a bit pleasant a moment ago . . . succeeded by a disturbed feeling."¹

There appears, therefore, to be a partial emotion when adrenalin is injected. Subjects do feel a bit stirred up, but that is all. Of course the whole range of physiological influences of emotion is not present.

Of provocative interest is this parallel statement,² which suggests a physiological basis to emotion.

"Twice within the last month I have had slight stomach upsets. During the day I have felt emotionally stirred up, a mixture perhaps of depression, vague unrest, and a feeling as if something were wrong, or that I had offended someone. Yet in neither case was there anything to which such feelings could be attributed, unless one seized upon one of the ordinary concerns of daily life. I am inclined to think the stirred-up feeling was nothing more than stomach upset."

Another question is whether actors feel any genuine emotion while playing their roles. Two important problems arise here. Does expressing an emotion lead to a genuine emotional experience? Does the actor feel genuine love, hate, scorn, or righteous indignation? Secondly, do the truly great actors really "live" their parts? As to the latter, testimony seems to differ. Some first-rate actors say that they are always acting, while others have stated that they really become the playwright's character and feel the situations they are portraying. As to the first question, daily-life situations suggest that one can work himself into an emotion. For social reasons, one will feign friendliness and joviality with a person previously disliked, and will soon find himself truly liking that individual. I once staged a fake quarrel with another instructor before a class, for experimental purposes, and actually felt distinct scorn and resentment while the experiment lasted.

6. Physiological Differentiation of Emotions

So far we have discussed emotions as if all disturbed conditions produced the same effects. We know what emotion we are experi-

¹Landis, C. and Hunt, W. A. Adrenalin and emotion. *Psychol. Rev.*, 1932, 39, 467-485.

encing, whether it be fear, amusement, envy, boredom, or whatever. Can these be differentiated in terms of possible visceral patterns, or are the differences entirely within consciousness?

(A) VISCERAL RESPONSES. Cannon [5] and several others have attempted to differentiate emotions in terms of internal reactions, but have met with only the most equivocal results. Measurements of blood pressure, breathing, and chemical changes of blood content have failed to reveal consistent patterns. For example, rage and fear are both violent emotions, but quite different in their causes and effects. In rage one tends to approach and grapple with the opponent; in fear, to get as far away as possible. Yet physiological patterns, so far as present-day instruments can record, are identical.

Differentiation may be made in two ways, however. (1) In terms of violence of emotion. This will separate the grosser emotions from the more subtle and refined ones, such as the mild pleasure experienced in hearing good music, from the violent expressions of stark terror or anger. (2) In terms of approaching or withdrawing. In general, it may be said that in the pleasant emotions a person tends to approach or to continue his activity, while in those inspiring unpleasantness he tends to cease that activity or to withdraw. But these means of distinction are far from satisfactory. There are a number of very intense emotions, many of medium intensity, and many more of mild character, and we desire to find some means of differentiating them.

These facts do not invalidate certain practical uses of measures of emotion, as in the "lie detector." There we are concerned only with the presence or absence of violent emotions, and not with what particular feelings might be experienced.

(B) PATTERNS OF EMOTIONS. Apart from visceral responses, it is possible that certain emotions have characteristic general patterns. The author once made a survey of the emotion of *excitement*. [13] This emotion is of interest since it has no definite stimulus and no specific response. The best approach seemed to be an actual life situation rather than a laboratory set-up. An analysis was made of the feelings reported by athletes as to their emotional states before competition. Most commonly reported physiological symptoms were frequent urination, hollow feeling in stomach, rapid heartbeat, and dry mouth. This might start as early as several days before the contest, especially if it was to be out of town, before a conference championship, or before the season's most important game. It was interesting to note that tension almost universally vanished as soon as the contest started, and in many cases when the men had put on their uniforms and had started to warm up. These various lines of evidence suggest that tension and excitement

are due to restriction of action or movement. In other words, restraint serves to heighten emotion, but as soon as action can be accomplished the person becomes calm again. Actual emotion could not be adequately described, except to say that it might be close to dread, fear, joy, or anxiety. Reports of subjects suggested merely that it was somewhat unpleasant.

Similar effects were reported from studies made on students just before examinations. In addition to verbal reports, such as those obtained from athletes, these investigators found such physiological symptoms as heightened blood pressure, increased pulse and respiratory rates, increased blood sugar, and glycosuria. Effects were greater in freshmen than in upperclassmen who were more habituated to the examination situation. However, seniors before their final comprehensives were considerably upset. [2, 3]

High-speed motion pictures were taken of subjects displaying *startle* in reacting to an unexpected pistol shot. [11, 12] Subjects were dressed in bathing suits so that all bodily movements could be identified unambiguously.

The pattern consists of shutting of the eyes and distortion of the features, a forward movement of the head, a raising and drawing forward of the shoulders, abduction, forward elevation, and inner rotation of the upper arms, bending of the elbows, pronation of the forearms, claspings of the hands contraction of the abdomen, forward movement of the trunk, bending of the legs at the hips and knees, and random foot movements. Not all of these elements are present in every reaction.²

A description of fear in children from a few months of age to five years has been given. The younger children gave vent to crying and other vocalizations, while the older ones restricted themselves to whimpering, catching of breath, and so on. More overt behavior consisted of running away or retreating, seeking an adult for protection or help, starting and jumping, and various facial contortions.

7. Facial Expression of Emotions

We have seen that it is impossible to differentiate between various emotions in terms of physiological patterns. Might facial expressions furnish any more accurate clues? To give a general summary first, there is some, but rather poor, accuracy in identifying the emotion an individual is experiencing from inspecting his photograph at a later time. Some emotions are spotted much more successfully than others. It might be remarked that satisfactory experimentation is difficult to

²Hunt, W. A. and Landis, C. The overt behavior pattern in startle. *J. exp. Psychol.*, 1936, 19, 309-315.

obtain, since posed photographs by professional actors tend to be exaggerated and conventionalized, and laboratory stimuli from which photographs are taken are somewhat artificial. It is difficult to get perfectly natural pictures of people in daily life expressing various emotional states.

(A) ACCURACY OF IDENTIFYING DIFFERENT EMOTIONS. Some emotional expressions, especially when the emotion becomes intellectualized, are judged much less uniformly than others. The primary emotions of love and hate, joy and sorrow, were much more uniformly interpreted than the secondary ones, like repulsiveness, surprise, distrust, and defiance. The following order of accuracy in identification was found: laughter (which is practically never missed), amazement, bodily pain, hate, fear, disgust, doubt, and anger. In other tests the following figures were obtained: horror was correctly identified in 65 per cent of the tests; resentment, 15 per cent; surprise, 5 per cent; passion, 3 per cent; fear, 29 per cent; mental suffering, 44 per cent; and perplexity, 6 per cent. [9, 19, 22]

Action furnishes better means of identification of emotional states than does a still picture as was demonstrated in a study using motion pictures. Subjects were photographed displaying eleven typical emotions such as awe, anger, astonishment, contempt, and stubbornness. University students attempted to estimate the emotion being displayed. The mean percentage accuracy was 91 per cent, in contrast to 62 per cent in judging the same emotions from still photographs. It might be added that this latter figure is rather higher than is usually obtained.

The tone of voice is another indicator of feelings. The same investigators made phonograph records of subjects expressing the same eleven emotions. [8] To control interpretation from content, each subject pronounced the letters from A to K; thus only the tone of voice expressed the emotion. The average correctness was 82 per cent, although there was quite a bit of variability.

In daily life we do not ordinarily judge emotions from photographs, but by looking at the individual himself. This gives a judge two advantages: he sees the face in motion, and he is familiar with the antecedents of the situation. If someone tells a risqué story and a certain look comes over one listener's face, we would all identify it as disapproval. However, if we did not know what had preceded the look, we might venture that the person was sad, had a stomach-ache, or had smelled something unpleasant. Even here there are individual differences. One person will keep right on with disapproved conduct; while another will be able to recognize the disapproval at the outset and change his tactics before he has made a bad impression. The successful

trial lawyer can often tell which jurors he has convinced and which are still in doubt, because he has the advantage of noticing changes of expression as well as the static poses which occur only momentarily for photography.

(B) PATTERNS OF EXPRESSION. Attempts to analyze the set of various facial features have met with a large degree of failure. It is true that certain consistencies do appear: mouth wide open in laughter, jaw protruding in determination, nose wrinkled in disgust, brow wrinkled in wonder or perplexity, and mouth turned down in scorn. But in attempting to prepare a table showing the position of each facial feature in each of these same emotions, there is immediately apparent a great deal of overlapping. Yet accuracy of identification from the whole intact face is reasonably good for several emotions. This suggests an important principle enunciated by the German Gestalt school of psychology, that "the whole is more than the sum of its parts." In this case it means that the tearing down of a face in an attempt to reconstruct the emotion from the component parts will result in failure, even though the intact face might be correctly interpreted.

There is a possible physiological reason why facial expressions of emotions should not be especially distinct. Electrical stimulation of facial muscles suggests that there are only three basic patterns. One pattern is that of tension, a second is that of relaxation, which would characterize sadness or fatigue, and the third pattern is that of disorganization, as in surprise or shock.

Landis [15] verified this theory in an experiment which also obviated the criticism of most laboratory procedures as being too mild in character to furnish valid evidence. He used quite a number of experimental situations, some of the more striking of which were the firing of an unexpected shot, reading aloud the subject's own story of the most contemptible thing he ever did, studying pictures of skin diseases, looking at pornographic pictures, being asked to decapitate a rat with a butcher knife (several of the subjects refused). Instead of certain situations producing standardized facial expressions, it appeared that each subject had favorite patterns which he displayed in a variety of situations. For instance, one subject uniformly closed his eyes, another quite generally opened them widely.

(C) ARE EMOTIONAL EXPRESSIONS LEARNED? It is obvious that the face shows emotions, yet they are not clearly or uniformly portrayed. Possibly each person acquires his own characteristic ways of expression. A good approach to this problem is by studying facial expressions of blind people, since they obviously could not have learned



FIG. 33.—Facial expressions during emotion.

Try to identify the emotions expressed in these seven photographs. The first four show a movie actress portraying four emotions, in order: horror, suspicion, indecision, and surprise. The fact that identification is difficult is even more significant since an actress, whether stage or movie, typically exaggerates an expression to show the audience what she is presumably experiencing.

In the three shown on the following page we have rapid-fire shots of actual expressions of individuals caught in the midst of violent emotional experiences. The first is amazing, when we learn that, rather than intense grief, relief of tension, perhaps joy, is the cause.



FIG. 33 (*continued*).—Facial expressions during emotion.

A relative of these people, imprisoned in a mine cave-in, has just been brought out safely. The second shows a girl escaping from a school demolished in a gas explosion which killed more than a hundred pupils. In the third we see a Chinese boy being forcibly held to be photographed. This is probably both fear and anger: fear of the strange device which might take away one's soul and anger from restraint.

from others. Goodenough reports such a study with a blind-deaf girl. [10] She expressed startle by opening her sightless eyes to the fullest extent. Disappointment at not being able to find something showed the response of head dropped forward on breast and one hand to the nose. Resentment produced turning of the head, pouting, and frowning. Her "laughter is clear and musical, in no way distinguishable from that of a normal child." Two Russian investigators claim that blindness is followed by a gradual deterioration of facial expressions. Presumably expressions become less and less pronounced and distinguishable.

As adults we control our emotional expressions; in a sense we are acting. Children express their feelings verbally and facially in a less restrained manner. But adults learn to conceal boredom, impatience, surprise, and even excessive joy. At times we put on a false expression: we feign interest while listening to an interminable pointless story. We laugh at a joke heard many times before. We look concerned at hearing of the death of a distant relative of a casual acquaintance.

Even when no attempt is made to cover up our feelings there may often be doubt as to what one is experiencing. Instructors watching students write an examination note a variety of expressions. It would appear that thinking is a painful process! Some expressions suggest that the student was sitting on a pincushion, was dying of thirst, or had lost a dear relative. Pictures of athletes finishing a distance race and exerting themselves to the utmost show anything but pleasure; their faces look more as though they had seen something gruesome. At a concert one never knows whether certain persons are enjoying the music, or were brought there against their will and are thoroughly bored. Aesthetic appreciation and other subtler feelings do not cause such marked expressions as do the grosser and more violent emotions.

SUMMARY

Emotions are stirred-up states, involving sensations spread over the entire body. For thorough study of emotions we need to use evidence from both behavior and verbal report. The nervous control of emotions lies in the cerebral cortex, in the thalamus, and in the autonomic nervous system. The last-named regulates the motor activities of the visceral organs. The cerebral cortex acts as a brake or governing agent over emotional expression. Some of the more important physiological changes during emotions are increased heart rate and blood pressure, more rapid breathing, perspiration, cessation of digestive activity, and increased output of adrenalin.

The internal aspects of emotions (visceral responses) can be used practically to detect emotional states, such as tension in the guilty criminal. Since these internal responses are involuntary and largely unconscious, they cannot be controlled as can verbal replies and facial expressions.

As to whether emotions can be felt in the absence of visceral responses, evidence is equivocal. Both human beings and dogs have displayed emotional upsets at times in spite of lesions in the nerves conducting sensations from viscera to the cerebral cortex.

Differentiation of emotions is inadequate, so far as physiological patterns are concerned. Interpretation of emotions from facial expression is also far less accurate than people are wont to assume. This is especially true if one does not know the situation surrounding the expression.

REFERENCES

1. Bard, P. Emotion: I. The neuro-humoral basis of emotional reactions. In "A handbook of general experimental psychology." Worcester, Mass.: Clark Univ. Press, 1934, pp. 264-311.
2. Brown, C. H., & Van Gelder, D. Emotional reactions before examinations: I. Physiological changes. *J. Psychol.*, 1938, 5, 1-9.
3. Brown, C. H. Emotional reactions before examinations: II. Results of a questionnaire. *J. Psychol.*, 1938, 5, 11-26.
4. Cannon, W. B. Again the James-Lange and the thalamic theories of emotion. *Psychol. Rev.*, 1931, 38, 281-295.
5. Cannon, W. B. Bodily changes in pain, hunger, fear, and rage. New York: D. Appleton-Century Co., Inc., 1929.
6. Cannon, W. B. James-Lange theory of emotions: a critical examination and an alternative theory. *Amer. J. Psychol.*, 1927, 39, 106-124.
7. Dana, C. L. The anatomic seat of the emotions, a discussion of the James-Lange theory. *Arch. Neurol. and Psychiat.* Chicago, 1921, 6, 634.
8. Dusenberry, D., & Knower, F. H. Experimental studies of the symbolism of action and voice. I. A study of the specificity of meaning in facial expression. *Quart. J. Speech*, 1938, 24, 424-436. II. A study of the specificity of meaning in abstract tonal symbols. *Quart. J. Speech*, 1939, 25, 67-75.
9. Felekey, A. M. The expression of emotions. *Psychol. Rev.*, 1914, 21, 33-41.
10. Goodenough, F. L. Expression of the emotions in a blind-deaf girl. *J. abnorm. (soc.) Psychol.*, 1932, 27, 328-333.
11. Hunt, W. A. Studies of the startle pattern. II. Bodily pattern. *J. Psychol.*, 1936, 2, 207-213.

12. Hunt, W. A., & Landis, C. The overt behavior pattern in startle. *J. exp. Psychol.*, 1936, 19, 309-315.
13. Husband, R. W. A study of the emotion of excitement. *J. genet. Psychol.*, 1935, 46, 465-470.
14. Landis, C., & Hunt, W. A. Adrenalin and emotion. *Psychol. Rev.*, 1932, 39, 467-485.
15. Landis, C. Studies of emotional reactions. I. A preliminary study of facial expression. *J. exp. Psychol.*, 1924, 7, 325-341. II. General behavior and facial expression. *J. comp. Psychol.*, 1924, 4, 447-509.
16. Luria, A. R. The nature of human conflicts. New York: Liveright Publishing Corp., 1932.
17. Jersild, A. T., & Holmes, F. B. Some factors in the development of children's fears. *J. exp. Educ.*, 1935, 4, 133-141.
18. Jersild, A. T., & Thomas, W. S. The influence of adrenal extract on behavior and mental efficiency. *Amer. J. Psychol.*, 1931, 43, 447-456.
19. Kanner, L. Judging emotions from facial expression. *Psychol. Monogr.*, 1931, 41, No. 186.
20. Langfeld, H. S. Judgments of facial expression and suggestion. *Psychol. Rev.*, 1918, 25, 488-494.
21. Larson, J. A. Lying and its detection. Chicago: Univ. Chicago Press, 1932.
22. Ruckmick, C. A. A preliminary study of the emotions. *Psychol. Monogr.*, 1921, 30, No. 136.
23. Sherrington, C. S. The integrative action of the nervous system. New Haven: Yale Univ. Press, 1906.

X

ACQUISITION AND CONTROL OF EMOTIONS

Emotions, like habits and knowledge, are largely acquired. Although there is disagreement concerning the type of emotions the newborn infant displays, authorities agree upon their scarcity, simplicity, and generality, in comparison with the multiplicity and complexity of an adult's emotional behavior. [13] In this chapter we shall examine the innate emotions and study their changes with age, experience, and training.

I. ACQUISITION

1. Innate Emotions

It is, of course, impossible to tell just what emotions the infant is experiencing, since he cannot speak. But there is no doubt that he does experience emotions. At any rate, his emotions can be broken down into pleasant and unpleasant. If pleasant, he remains quiet and relaxed and often vocalizes (like a kitten purring). If unpleasant, he is tense, struggles, and utters sharp cries. Anger and fear are both innate emotions, expressive of an unpleasant state of feeling.

Jersild and Holmes [4] made a thorough study of fears, their native aspects, their development and conditioning, and their control and removal. Previously, fear was supposed to come from two sources only: loud noise and loss of support. Their analysis of the fears of hundreds of children showed that previously accepted theories of fear were oversimplified. These two causes of fear are correct enough, but they do not represent the entire story. Careful investigation discloses such additional situations as threatened loss of support (such as jiggling the bed), flashing of a bright light, a sudden movement of hand

or body, a quick touch, and even the presence of strangers (when distance vision has developed so that the infant can differentiate faces).

All these stimuli produce *psychic shock*. Any radical change in the environment tends to cause uneasiness and the more rapidly it occurs the more fear-inspiring it is. It might readily be, for instance, that just as the average baby cries because of loud sounds, so a baby raised in a busy part of a city might be disturbed by the quiet of an isolated farm. A stranger represents an unusual element in the environment, and seems to produce fear in proportion to his unusualness. A white child is often frightened by the first Negro he sees. One child who was raised largely by Negro servants—its mother was much occupied socially—acted uneasy in the presence of white people. A Halloween mask will thoroughly frighten a child.

In adults the psychic shock explanation of fears still holds true. We are startled by a loud sneeze, an unexpected peal of the doorbell, a cymbal crash in an orchestral selection, and even by threatened injury, such as a light object dropped harmlessly on the foot. The presence of strangers is likely to make us uneasy. Suppose we go to a large party where most of the guests are strangers. We feel nervous and self-conscious, and are not at ease until we have become acquainted. We are likewise inclined to be ill at ease in a strange city, the first night on a sleeping car, or when we first arrive at the university.

To make the matter more complex, fears often have multiple origins. A child who was afraid neither of animals nor of loud noises became frightened when someone showed him an animal and roared at the same time. Another child was not afraid of the dark at home, but he became disturbed in a strange house. Many fears are specific. A given child may not be equally afraid of all loud sounds, nor of all animals, nor of all dark rooms. This last fear involves learning, and so is not entirely a question of innate endowment. One group of investigators reported that the following situations, often thought to represent native fear-producing stimuli, are not really feared by children unless they have been associated with a terrifying event: the dark, water when in a boat, cats and dogs, frogs, snakes and worms, high places, thunderstorms.

The supposedly native fears were tested by Jersild and Holmes. [4] In Table 16 we see the proportions of children between two and six years of age who responded by fear behavior in the various situations listed. Again we see a demonstration of the complex nature of fears. Some which have been assumed to be native are weaker than others which are undeniably acquired. Animals and darkness are much more potent stimuli than falling or noise.

TABLE 16
 PERCENTAGE OF CHILDREN WHO SHOWED FEAR IN RESPONSE TO VARIOUS
 EXPERIMENTAL FEAR SITUATIONS

SITUATION	PER CENT SHOWING FEAR
1. Being left alone in room.....	11.5
2. Falling boards (dropped two inches while child was walking on it) ..	11.5
3. Dark room (gloomy, not totally dark)	41.3
4. Strange person (asked to get toys from table at which strange veiled woman was seated).....	20.2
5. High boards (4 feet from ground).....	27.2
6. Loud sound (hitting pipe with hammer).....	17.5
7. Snake (child asked to look in box and get toy).....	44.2
8. Large dog (pat collie on leash)	50.0

Anger is possibly less complex. Restraint is the primary stimulus. It may be directed toward objects, toward other people, or even toward oneself. In the young child it is manifested by struggling when held physically. When the child is old enough to talk and walk, he has had opportunity to be subjected to some conditioning. Goodenough [1] reports outbursts during the following activities: brushing teeth or washing hands, dressing and undressing, bathing, going to toilet, going to bed, while in bed, during meals, playing alone, playing with others, hearing stories or music, waiting for some expected event, and when unoccupied (bored from being kept indoors, perhaps). These are all situations. Stated more generally, the immediate causes involve: restraint of any kind, being forced to do something unpleasant, being forced to give up something pleasant, being interrupted. Being forced to stop playing, even to come to dinner—ordinarily pleasant in itself—may be cause for outbursts. Being forced to go to bed, to wash the hands, being ignored, and being balked are other examples. In this investigation objections against routine habits such as bathing or dressing made up about a fourth of the total, problems of social relationships another quarter, physical discomforts a third quarter, and the others miscellaneous. Actual physical restraint from some desired movement accounts for only 6 per cent. Social difficulties become increasingly important as the child approaches school age.

In the adult, restraint is usually not physical, but social. The student becomes angry when his parents refuse to allow him to have a car or go to a dance in the middle of the week. I have seen a girl become so angry because she had to take an afternoon class that she stiffened and jumped up and down, exactly like an enraged baboon. A man became very red in the face upon being refused the privilege of buying a house he desired. We may even display temper at our own clumsiness, as when we drop a dish and break it.

The third class of emotions, which has already been given in sufficient detail, is the reaction variously called love, sex, or sensitive zone.

2. Changes and Growth of Emotions

Frequently in this book we have discussed learning. Learning entails the formation of emotional, as well as motor and intellectual, habits. It is just as much a habit to be afraid of the dark or of high speeds in motorcars, or to be angered by traffic lights, as it is to draw pictures while waiting in a phone booth, to light a cigarette automatically at the conclusion of a meal, or to use certain favorite expressions in speaking. The term "habit" implies merely that one behaves in a fairly uniform way in certain similar situations.

Several characteristics of emotional learning should be mentioned. [2] (1) Improvement often occurs suddenly, in contrast to slower progress in intellectual or motor tasks. (2) Emotional habits are probably more permanent than most other habits. (3) They may transfer to other situations; intellectual habits remain specific. (4) Emotional habits are not learned deliberately, although other types of learning are usually consciously and deliberately acquired.

(A) **ADULT EMOTIONS.** As adults, our emotional life is exceedingly rich. Infants probably have few specific emotions, although relatively violent ones, while adults experience amusement, aesthetic pleasure, friendship and love, admiration, scorn, disgust (social and physical), anticipation, remorse, and countless others. Such emotions are less violent, more restrained, and more social in character than the innate ones. For example, as adults we are less often afraid of loss of support, loud sounds, and similar causes of "psychic shock" than we are afraid of making a blunder at a formal dinner, getting hurt in an automobile accident, or failing in business. Many adult fears involve dread of possible unpleasant consequences, while native fears are produced by realities or by things which have already occurred. Below a certain age children do not think ahead enough to worry over the future; whereas an adult may worry for days over the prospect of a few seconds' pain in the dentist's chair.

In the case of anger, adult emotions seem more closely built upon native origins. Restraint of various sorts is the cause of almost all instances of rage. A person gets angry if he is crowded in a bus so that his movements are limited physically, when he cannot pass a slow driver who sticks to the middle of the street, when something prevents his attending a desired social function; in short, when his will has been thwarted in some way.

(B) **MATURATION OF EMOTIONS; CHANGES WITH AGE.** New emo-

tions appear and old ones change as the child grows up. This may be due to maturation or to learning, or to both. If maturation, it may be that certain emotions cannot be expressed in infancy. Just as a child cannot walk during the first year, so perhaps some emotions cannot appear until he is older. For example, feelings of remorse or guilt necessitate learning that certain actions are not approved, as well as sufficient intellectual maturity to apply the general principle to the particular situation.

Studies on this subject were conducted on preschool children and on children between five and twelve. [6] The following general trends were found: (1) With age, there is a decline in fears of tangible things, such as noises, strange objects or people, and unusual situations. (2) Fears of imaginary things increase: darkness, fanciful animals, ghosts, robbers. This accompanies growth of the imaginative and thinking processes. These fears of imaginary things are at their peak at about five years. At six, the child is beginning to realize certain environmental dangers, such as neighborhood bullies and accident possibilities. Also social appreciation begins, bringing with it worries about not being successful.

3. Emotional Learning

An emotional pattern is usually formed as follows: (1) sound of thunder causes fear; (2) lightning followed by thunder causes fear; (3) lightning becomes associated with the loud sound and now causes fear before the thunder is heard. Thus, a new stimulus now stands for, or means, the original or native stimulus, and produces the same effect.

Harlow [2] has distinguished five ways in which emotions are acquired.

(A) IMMEDIATE AND DIRECT CONDITIONING TO A SITUATION. This occurs when a person becomes afraid of dogs after having been bitten. Some writers even suggest that all emotional acquisitions originate in this manner, but there are difficulties in the way of accepting such a universal explanation. This is especially true in attempting to explain the acquisition of social emotions like sympathy and tenderness.

(B) IMITATION. The capacity to fear is innate, but the specific situations which inspire fear are acquired. Many such specific fear stimuli are copied from parents, older brothers and sisters, playmates, and acquaintances. One investigator found a remarkable correspondence between specific fears of children and those of their mothers.

A mother was the near-victim of a run-away horse before her son was born. The son is now afraid of horses, which the mother asserts is obviously inherited, because, "I have always been especially careful to see that John

stayed away from horses. Why, even when he was a little tot, I made him promise me that he would never under any circumstances go near horses, or have anything to do with them."¹

We would, of course, disagree with her explanation and disapprove of her method of rearing her son.

Two specific instances: A girl of three had previously shown no fear of the dark, but she acquired it from overhearing her older brother insist on having his bedroom door open and the light in the hall burning. A college girl was so afraid of caterpillars that she would inquire about their possible presence before accepting an invitation to a picnic. When questioned, she said that she had never had any unpleasant personal experience with caterpillars, but that her mother did not like them.

(C) TRANSFER, OR SPREAD, OF EMOTIONS. Often emotions, rather than remaining specific to their original situation, spread to other more or less similar situations. Table 17 shows a few samples.

TABLE 17

FEARS OF CHILDREN WHICH GREW OUT OF PRIOR FEARS [6]

PRIOR FEAR	NEW FEAR
Fright at sound of applause on radio	Fear of all radio
Sound of mouse running through bedroom	Fear of any scratchy sound at night
Fright at sudden hooting of owl	Fear of familiar pet canary, not previously feared
Fright when attacked by police dog	Fear of dogs; fear of cats as well
Fright at being left alone in hospital	Fear of dark, fear of imaginary animals, nightmares concerning animals

(D) VERBAL LEARNING OF EMOTIONS. Many of the emotions acquired after early childhood are learned not by direct experience, but by listening or reading. Campaigns to reduce automobile accidents, by articles, photographs, and speeches on the terrible accident toll produced by careless drivers, are being waged in the hope that learning will result. Attitudes are similarly formed. They are classified as emotional, because they are founded upon prejudice and belief rather than reason. We look down on members of a certain race or religion because we have overheard an isolated example concerning that group, or because of consistent group attitudes. Attitudes toward social issues, such as morals, drinking, and Sunday observance, are largely imitated from one's parents and associates. In mental hygiene literature we find case after case of marriages wrecked because the parent (usually the mother) of one of the partners has had an unhappy marriage and has given her daughter a pessimistic and distorted idea of relations between the sexes.

¹Harlow, H. F. Fear. 1937. Privately printed by author.

Fears of imaginary objects can be acquired in a verbal fashion. Hair-raising "bedtime stories" on the radio induce nightmares and hysteria in some children. Similarly, newspaper stories of epidemics and of certain types of crimes cause waves of fear, which in many instances replace fears previously held.

(E) EMOTIONS MAY BE ACQUIRED FROM PICTURES OR DREAMS. We cite two instances.

After attending a movie Nancy showed marked fear of storms. When it started to rain, she cried, ran to her mother and asked assurance that they would not be drowned. The fear was apparently derived from a news reel showing pictures of the Ohio River in flood time.

Johnny dreamed one night that he was chased by a wolf when visiting a friend's house. Since that time he has been quite unwilling to visit the friend at his home and the one time that he did go there he was restless and uneasy.²

These two types of emotions, acquired by words or by images, are far less potent than those which originate in the individual's own experience. For instance, a person undoubtedly would become much more cautious about driving an automobile if he saw one of his close friends meet with a serious accident than if he saw a newspaper description or a photograph of a similar mishap to a stranger.

4. Persistence of Emotions

A group of adults were asked to list fears which they had had in childhood, and to check those which still existed. A third of the total remained. Such figures are crude, of course, since many childhood dreads are forgotten and present fears actually may have originated in childhood even though their origins have been forgotten. The fact remains that many fears had lasted over a period of many years. Two chief classes persisted: (1) Fear of animals and of bodily injury through falling, traffic, or drowning. (2) The persistence of imaginary fears, of supernatural powers and of criminals, demonstrates the power and endurance of emotional experience as against the reasoning faculties.

Then, too, an emotion may receive reinforcement from time to time. Here is a case reported by a college girl.

I have always been afraid of feathers—so much so that I won't wear them on my hat, and if I have to touch one I put my gloves on. When I was three and a half a hen flew at me with much fluttering. When I was twelve, a robin flew out of the bush while I was picking a wild rose. I even

²Harlow, *op. cit.*

get goose pimples if feathers are mentioned in a conversation, and I won't sleep with a feather pillow.

Probably the brutality exercised on many children and some adults with regard to fears has intensified rather than cured them. When children find that one of their friends is afraid of something, they take every opportunity to confront him with the object of his fear.

There is overwhelming evidence in the literature of abnormal psychology, psychiatry, and psychoanalysis that memory for emotional events far surpasses that for intellectual material. Many likes and dislikes, prejudices, annoyances, and specific fear and rage stimuli originate in the first few years and last all through life. Severe abnormalities are sometimes caused by emotional conflict, such as the struggle between love and family ties when the family opposes a certain marriage. The conflict may be temporarily settled by insanity (a person in an institution who believes himself president is often happier than the real president), by the development of an amnesia, a dual personality, or an hysterical paralysis. But the fact that the symptoms persist for long periods of time, perhaps in spite of psychiatric treatment, demonstrates that the emotion is still present, even if somewhat altered in form.

5. Humor

Although laughter is a common human characteristic, its causes and explanations are manifold. Dozens of books have been written about it, and many theories of humor have been advanced. We cannot explain all humor by any single theory; so we shall point out various situations which produce laughter.

THEORIES OF HUMOR. We classify here several different situations which provoke amusement. [10, 11, 12] They center mainly about three situations: superiority, surprise, and repression.

(1) *Superiority* is one of the most frequently mentioned theories. This is seen typically in the raucous laughter heard during a movie comedy when someone falls downstairs, is hit in the face with a pie, or is placed in an unfavorable light. The theory behind this is that the watcher is thereby rendered superior. We laugh when someone falls down, strikes out in baseball, or becomes confused in his speech. If that someone is distinguished, the humor is thereby enhanced. We do not laugh if a child or a cripple falls into a mud puddle; we are already superior. If a friend falls down, we may laugh mildly. But if a distinguished person with frock coat and silk hat meets with such a misfortune, our ego is raised that much more. If the slugger on the opposing team strikes out there is glee over his humiliation.

Some comedians deliberately provoke laughter by pretending stupidity and thus flattering their audiences. They make silly remarks, keep a "dead pan," and allow themselves to become the butt of others' remarks.

Unintentional blunders furnish their humor by raising the listener's feeling of superiority, as in this episode :

A rather uncultured but wealthy woman at a concert remarked, "I see the next piece is by Beethoven; I adore these modern composers." "Why, didn't you know that Beethoven was dead?" "Goodness gracious me, I didn't even know he was ill."

If the tables are turned on a person we have both superiority and suddenness enhancing the humor.

At a formal dinner a distinguished Chinese statesman was seated next to a rather tactless American. During the first course the latter turned to the guest, and asked, "Likee soupee?" After the dinner the Chinese was asked to give a talk, which he did in faultless and polished English. When he sat down, he glanced at his table-mate and inquired "Likee speechee?"

An American who had spent a few weeks in Mexico returned claiming a knowledge of Spanish. A Mexican radio station happened to be turned on in the hotel lobby, and he laughed uproariously from time to time, interjecting, "Too bad you fellows don't understand Spanish; this is one of the funniest programs I have ever heard." At the conclusion the announcer suddenly changed to English, "You have just heard the closing quotations of the New York Stock Exchange."

It has been demonstrated that a joke on oneself or one's own group fails to arouse the mirth that is created if the victim is changed. The following joke can have the two races interchanged, and the glee will turn into a sickly smile, or vice versa, depending upon whether one's group comes out on top or gets the worst of it.

A Jew called up a Scotch doctor and inquired the price of office calls. He was told that the first one was \$3 and that subsequent calls were \$1 each. He appeared, and said, "Hello, Doc, here I am again." The Scotch physician replied unhesitatingly, "Fine, continue the same treatment. One dollar, please."

(2) *Unexpectedness or sudden shift.* Here are two samples :

Mary had just served John ice cream and cake. Then they took seats on the divan. Slowly John began to slip his arm about her. She said, "Don't hesitate, John; do what you want to." Without a word, he stood up, went to the ice box, and took another dish of ice cream.

Boss, to late employee, "If you ever are late again you will get what you deserve."

"Thanks, boss, I can use the extra money."

There are two techniques in storytelling which will accentuate this factor. Speed of telling will enhance the joke. "Brevity is the soul of wit" is a familiar saying which public speakers could adopt with profit. We have all heard perfectly good jokes utterly ruined by being protracted unduly. A second suggestion is to tell the joke in the first person, implying up to the last moment that it is a bona fide personal experience. The surprise accompanying the climax will double the humor when the listeners realize that it is an imaginary situation, after all.

(3) *Relief* is possibly closely allied to unexpectedness. A movie audience sits in tense silence while a runaway train rushes down a mountain, and when the situation is saved there may be a general wave of laughter. Tense situations have often been relieved by a jest.

Calvin Coolidge, while President of the Massachusetts Senate, met a difficult situation. The debate had become more personal than parliamentary, and one senator told another to go to hell. The rebuffed Solon protested with extreme seriousness to Mr. Coolidge.

"Cal, did you hear what So-and-so said to me a moment ago?"

"Yes," he replied, without the semblance of a smile, "but I've looked up the law, and you don't have to go."

Who could nurse a grudge after that?

(4) *Incongruity* may produce laughter, even when the situation seems inappropriate. At a concert after a series of ever-increasing crescendos the piece suddenly ended with a deafening climax. A woman's voice was heard shrieking to her friend, "Well, I always fry them with onions."

"Which animal is the brightest?" "I give up." "The rabbit, because he multiplies the most rapidly."

A mother was telling her small daughter about God. "He is all-powerful; there is nothing that he cannot do," she said. "Well, I'd like to see him put back all that toothpaste I squeezed out of the tube this morning."

(5) *Ridiculous* sources of humor are seen in puns, spoonerisms, and plays on words.

A "kiss" is a noun though generally used as a conjunction. It is never declined and is more common than proper. It is not very singular and is generally used in the plural. It agrees with me.

Two students walked by a building. One read aloud the sign, "Board of Education." The other sighed, "So am I."

You may think that you are witty, but the man who wrote "Snowbound" was Whittier.

Some college girls pursue learning; others learn pursuing.

"Pardon me, you're occupewing the wrong pie; let me sew you to another sheet."

A man constantly annoyed his friends by far-fetched puns. With the hope of curing him, they arranged to have him arrested, given a fake trial, and condemned to be hanged. Just as the rope was being adjusted around his neck, a motorcycle messenger purporting to be from the governor rode up with a reprieve. As the rope was untied, he said, "Well, no noose is good news."

(6) *Exaggeration*, which may involve either over- or understatement, is at the basis of many jokes.

A cartoon shows a man planting his garden, with some friends watching. He holds a seed in his hand, hesitates, and then says, "When I drop this seed, duck backwards."

A farmer on his first stay in a city hotel was rather bewildered by the long menu presented him. After an uncomfortable pause the waiter ventured, "Might I suggest an egg, sir?" The farmer sniffed, "*An egg! An egg! Why, I wouldn't get my plate dirty for less than five.*"

Here are two episodes which derive their humor from apparent understatement.

A woman complained to the telephone company that two linemen working outside her house had used terrible profanity. Called in to tell what had been going on, one of them told his story as follows: "It was this way. George and I were working on the pole, with him at the top. He spilled some melted solder down the back of my neck. I just looked up at him, and said, 'Really, George, you *must* be more careful!'"

Daniel Boone was once asked if he had ever been lost. "No," he replied, "but once I was bewildered for several days."

(7) *Repression* furnishes the source of enjoyment of jokes centering about sex and other forbidden topics. When twelve jokes were given to six hundred students of both sexes to rate, the three which involved sex (although mild enough to print without possible criticism)

were given the three top places. The funniest is reproduced below; the third was the first sample under "ridiculous."

This is a sample of the child's being deformed before birth by a mental shock to the mother.

An expectant mother was living in a public boarding house. There was only one bath, which was shared by all. One afternoon she went to bathe. When she opened the door she saw a naked man in the tub, which experience caused her extreme fright. Three months later her baby was born without any clothes on.

It would probably be possible to make any subject humorous by prohibiting or frowning upon frank and open discussion. A popular article relates how the European dictatorships have given rise to many new stories. [8] Here is one:

Mussolini entered a motion picture theater incognito. In the course of a newsreel his own image appeared on the screen. Instantly everybody rose and cheered. Only the dictator remained seated. His neighbor thereupon poked him in the ribs. "You'd better stand up, my friend; we all feel the way you do, but it's not safe to show it."

During the prohibition era many jokes in humorous magazines centered in one way or another about drinking. Now that that artificial repression is past, this type of joke has greatly diminished.

II. CONTROL OF EMOTIONS

1. Necessity of Control

(A) **NECESSITY OF INHIBITING EMOTIONS.** Although emotions were originally of definite survival value, in civilized society it is seldom advantageous to become thoroughly angry or thoroughly afraid. In fact, such expression may lead to serious trouble. A sudden burst of anger has led to the loss of a job, quarrel between friends, marriage failure, and even murder. The person who is "afraid of his own shadow" is greatly handicapped in participation in the normal activities of life. The less easily we acquire fears and the better we can control them the better off we will be.

At the same time we do not wish to suggest that emotions are undesirable, superfluous, or worse. Some of them we cultivate deliberately. We would not want to do without the joys of friendship and love. Many of us take courses in art and music so that we may heighten our emotional lives through aesthetic experiences. Young children must

often be trained to show sympathy for less fortunate persons. A certain degree of fear and anger is desirable. Accidents would be more numerous if people were not afraid of traffic or of leaning out of a skyscraper window. A child should not be totally devoid of anger. He should be resentful of intrusion upon his property or personal rights, although the manner of expressing his anger should be restrained.

(B) **WILL FEARS BE OUTGROWN?** In the preceding chapter we saw that certain types of fears are most prevalent at certain ages and that others develop later. Does this suggest that the child will grow out of any specific fear? If so, special training would be unnecessary. If not, it becomes necessary deliberately to remove and control undesirable emotions.

Although certain fears rise and wane, many persist into adult life. Fear of the dark, of fancied dangers, and of criminals are among the most common. Most adults are at least a trifle nervous when they walk at night down a narrow country lane lined with trees. Slight noises heard in the middle of the night induce terror in many adults. But in general, fears decrease gradually with age. Likewise, anger diminishes: we learn that we have to give and take, and we control selfish outbursts. However, such changes are so slow and uncertain that definite adjustments are frequently necessary.

2. Methods of Removing Fears

Jersild and Holmes asked a good many mothers what methods they had used to remove fears from their children and what success they had had with each method. The methods were grouped into ten classes. [5] We shall mention each and indicate its relative effectiveness. A method was considered successful only if the fear was removed permanently. If it persisted or returned, the method was not considered successful.

(1) *Verbal explanation and reassurance.* This method involved explanation of the true cause of thunder and lightning, the non-existence of ghosts, the ability of most houses to stand against strong winds, and so on. This method, used by itself, worked successfully 41 per cent of the times it was tried. Effectiveness of the method depends upon the confidence the child has in the older person. Hence a parent could use this approach better than a stranger or even a professional psychologist.

(2) *Verbal explanation and reassurance, plus demonstration.* The father shows the child how an electric motor works. The mother takes him into the cellar, lets him watch her wander about, and thus proves that there is no wolf there. Some of these attempts worked (47 per

cent); some didn't. Failures were possibly due to inability to understand.

(3) *Example of fearlessness in others.* Demonstration, as in the case where a mother waded into water ahead of the child, failed to relieve fear in more than a third of the cases.

(4) *Association of feared stimulus with pleasant, familiar, unfeared stimulus.* This is the method Watson, the behaviorist, urged so strongly, but Jersild and Holmes found that it worked only about half the time. One child lost his fear of thunderstorms when his mother regularly played ball with him and played the piano for him during such storms, but in another child the playing of pleasant music did not abolish fear of the dark. This method aims to change the meaning of the situation from thoroughly unpleasant to at least partially pleasant. The method fails when the predominant emotion is unpleasant.

Watson initiated a now-famous method of curing undesirable fears. [7] A boy was afraid of rabbits and other furry animals. He was seated in a high chair at one end of a large room, eating a meal. A rabbit, confined in a wire cage near the other end of the room, was displayed to him. Over a period of several days the animal was moved gradually closer and closer to him, each time care being taken not to bring it any closer than the point at which the boy began to show symptoms of concern. After a number of days the rabbit could be placed upon the table, even in his lap, and finally the child would eat his lunch while petting the rabbit with one hand.

(5) *Compelling child to participate in actual situation by force or by ridicule.* This is quite commonly done by parents, teachers, and playmates. The child is forced to go into a dark room, he is "cured" of fear of high places by being placed on a table and left there. More stringent methods, such as throwing him into water or pushing him from a high diving board, are sometimes used. Verbal methods may be just as painful. The child is made the butt of ridicule by parents or playmates. This method was reported to have been successful in but 10 per cent of cases. In fact, we might discount even this small proportion, as such stringent methods increase rather than reduce the fear in as many cases as they benefit. If Watson, in the example cited in the previous paragraph, had hastened the bringing together of child and rabbit, no doubt his efforts at re-education would have encountered setbacks.

(6) *Giving child opportunity to grow familiar with feared event in daily routine.* Toy rats may be left about the house; a pet dog may be brought into the house for children to play with. The child may avoid the stimulus or not, as he sees fit, but it is always in his environment in

a passive and harmless way. This procedure seemed to be highly successful, having worked in 82 per cent of cases. Here is one instance where it failed: a father carried the child into the water with him on his shoulders, but the child did not get over his fear of going in alone.

(7) *Introducing child to feared stimulus by degrees* is another effective method, having proved successful in three-quarters of instances. By this method the child is exposed to progressively more and more "shocking" situations. A child who was afraid of masks was habituated to them by giving him a smiling one at first, and gradually introducing less pleasant ones. Fear of running water was eliminated by turning on a faucet gently, and increasing the force bit by bit. Parents have cured children of fear of the dark by turning the light in the bedroom off but leaving the hall light, dimming the hall light progressively for a week or two, and finally dispensing altogether with illumination. This method is also applicable to adults who desire to conquer fears in themselves. A person who is afraid to dive from a high springboard may start with lower ones and gradually work up.

Whichever method is used, the process of rehabilitation should go on gradually. If the individual is forced to do something against his will, he may suffer an emotional crisis and slip back. The treatment should be patient and gradual. It is somewhat like climbing an icy slope; one misstep and a person may be plunged right back to the bottom of the grade.

(8) *Attempting to promote skill with the feared stimulus.* A child was afraid to enter a certain room; so the mother, taking advantage of his willingness to run errands for her, sent him to other rooms and finally into the feared room. The child overcame his fear by activity; he had a specific reason for going to the once-feared place. Fear of dark was overcome in another instance by installing a phosphorescent pendant from the light chain. The child was intrigued by it, and the game of spotting it in the dark (the darker it is the more it glistens) overcame his reluctance to enter the dark room. Such procedures were reported to have worked 90 per cent of the time.

Distraction in the form of excitement may assist in overcoming fear. A boy who was afraid to dive from a five-foot wall did so when it was demanded at the start of a swimming race. When the gun was fired he forgot all about his fear and dove in, thinking only of the race. A mother managed to overcome her child's bashfulness with strangers by having them discuss something of interest to him and gradually drawing him into the conversation. With fears of a minor character, a common-sense approach is to ignore them and hope that they will wear themselves out.

(9) *Ignoring the child's fear*, on the theory that if he attracts no attention the emotion will vanish, succeeded only a sixth of the time.

(10) *Removing the cause of fear*, such as keeping him away from dogs, never making him enter a dark room, or never leaving him alone, was permanently successful in only 10 per cent of the instances. This percentage is so small that it is probable that most of the fears removed would have cured themselves in time.

3. Control of Anger

Regulating anger is in several ways more difficult and less tangible than controlling fear. But such regulation is probably more important socially than the removal of fears. A person must learn to give in gracefully if he is to live successfully in a society where the individual must often be restricted for the good of the group. Many temper tantrums are inspired by pure selfishness; the child or adult has been restrained in some way and feels abused. The consequences of anger are obviously social in character.

In general, there are three major ways of controlling anger. First, the child should be taught that compromise is necessary to social living, and he must get over the tendency to become angry at every frustration. The earlier such an attitude is formed the better, since it is difficult to break antisocial habits later in life.

A second means of control is regulation of the environment so that its demands are within the scope of the individual's ability to attain. Just as an adult may become angry when he bungles a delicate and complex task, so will a child become angry when asked to perform an assignment beyond his capacity. Failure may be due to youth, to backwardness, or to clumsiness. Temper tantrums often occur when children are kept after school because of a low grade, and sometimes the poor mark was no fault of the child's. Possibly he is of low scholastic aptitude; perhaps he needs glasses or has a special reading disability. Parents often make the mistake of taunting a child with the accomplishments of an unusually gifted older brother or sister. On several occasions we have discussed the danger of reducing a person's ego; now we meet the principle again, from a slightly different angle. The person may attain normal emotional balance if he is given the opportunity to take pride in his accomplishments. If not too gifted, he may be placed in an environment more suited to his aptitudes. If good at one thing and poor in another activity, he should be allowed to capitalize upon his excellence while diverting attention from his weakness.

The social nature of anger furnishes the third clue to control. If a child is left alone, he realizes that his wailing and kicking will do him

no good and soon subsides. A kindergarten teacher handled a difficult boy effectively and with a minimum of friction by simply ignoring him. A spoiled child from a rich family, he refused to wash his hands before coming to midafternoon lunch with the other children. Instead of chastising him, she told him simply that the rest were going to eat and that when he had washed his hands he could join them. In a moment or two he had joined them quietly, and with clean hands. The teacher had placed him in a situation where he stood to lose more than he could gain. A grouchy adult can often be handled in the same way. He will never come to terms if he is cajoled, humored, and made the center of attention. But if his temper causes people to leave him alone, causes him to lose friends, and removes him from desirable social pleasures, he will begin to inhibit his selfishness.

Punishment brings up certain problems. Parents hate to punish a child who is showing anger, since punishment only heightens the emotion. But giving in to the child is similar to bribing him in that it palms off the present against the future. Every time parents give in or coddle, it is easier for the child to get his own way the next time.

Three positive suggestions are given by Goodenough [1]: (1) Don't give in to the child if he is angry. (2) Be regular and consistent. If the child is allowed to sit up late one night and is forced to go to bed at dusk the next, he will naturally feel that he is being treated unreasonably. (3) Avoid tension in the home. When parents are constantly screaming "don'ts" and are predisposed to be highly emotional themselves, the children will reflect such instability in their own behavior.

4. Forestalling Emotions

Perhaps we should have discussed ways of preventing the acquisition of fears before we considered their removal. A removed fear often does not entirely disappear. Expression of the fear may vanish—the child is able to swim, enter a dark room, or stand on the edge of a cliff—but that does not indicate that squeamishness has disappeared. If the fear had not been acquired, no hesitation would have been evident.

Man, aged 30, had never learned to swim because he had spent his boyhood in a state where the streams dried up in the summer. On moving to a different section of the country, he felt ashamed of his inability when on swimming parties during the summer. So he determined to learn. One of the most serious difficulties was his fear of the water. He felt panic-stricken under water. He had great difficulty learning the crawl stroke, as he became frightened at putting his head partially under water, and found himself unable to breathe out under water, which that stroke demands. So he

had to compromise with an awkward side stroke, head held high out of the water. A friend suggested that he hold his face and practice breathing out under water while standing only waist deep, but even in this safe depth he had to exert the most extreme will power to do so.

Comment: we notice in this case the strength and permanence of a fear. Yet a mature adult had determined to overcome his lack of skill. He reported that he had had no unpleasant experience in childhood which might have reinforced the emotion.

Three important reasons for forestalling fear have been suggested by Harlow [2] : (1) Once formed, a fear persists for a long time; (2) fears spread widely, and each additional fear predisposes the individual to acquire others; and (3) once a fear is formed, it is eliminated only with the greatest difficulty.

A number of approaches toward prevention of fears and anger have been suggested by various writers. (1) *Promote skills*. This should be done before conflicts arise. The very young child does not appear at all afraid of the dark. Keep him accustomed to sleeping in total darkness so that it will be accepted as a matter of course. Children taught to swim at a preschool age take to the water readily and regard it as a "friend" rather than a danger. The chief justification of kindergartens is the development of social participation so that later the child will not be fearful in the presence of adult strangers.

(2) *Force of example*. Many fears, we have noted, are acquired through imitation. Therefore, the adult must be especially careful of his own conduct. When an adult takes a child swimming, first tests the water gingerly with his toes, hesitates a long time before going in, and then shows relief at not being drowned, he need not wonder that the child cries out at his first "ducking." The adult, at least when accompanied by a child, should display nonchalance near water, in high places, during thunderstorms, and in the presence of animals.

(3) *Gradual habituation*. Don't change the child's environment too suddenly or expose him to stimuli of too great magnitude. Children sometimes become terror-stricken on seeing a badly crippled person. They may be told previously that Mr. Smith is very nice, but that he has a bad scar on his face or that he walks with a limp; then the shock of seeing him will not be so great. Similar caution is advisable in the physical sphere. It is well to accustom the child to water by going gradually from shallow to deeper water as his confidence builds up. This is similar to method number seven for removing already established fears.

(4) *Don't threaten*. We hope the reader fully realizes that emotions are not to be trifled with. They have too great permanence and are too likely to spread. It is a serious mistake to threaten a child with being

locked in a closet, being thrown out of a window, being given to the gypsies, or being thrown into the water.

(5) *Explain previous to experience.* Tell about the fun in swimming or about the large crowd that will attend the family reunion, so that the child may expect to enjoy himself. One should, however, be careful to avoid giving the matter such emphasis that the child becomes unduly wary. If one says, "The water won't hurt you," it may suggest a danger which otherwise never might have occurred to him.

(6) *Avoid criticism.* If minor fears are ridiculed, the child may begin to feel inferior and, instead of making extra efforts to participate in dreaded situations, will withdraw from them. Thus, a comparison which places an individual at a disadvantage makes matters worse rather than better.

(7) *Keep home situation pleasant.* Often children who display anger frequently come from homes where treatment of the children is not consistent. They may have irregular hours of retiring, alternately harsh and lax discipline, their clothing may be cumbersome or showy rather than comfortable, or their playthings may not be adapted to their strength. These children have been balked constantly and their dispositions usually show it.

5. Jealousy

Jealousy is an excellent emotion to use in a discussion of forestalling emotions; it appears to be entirely acquired, is difficult to remove, but with proper treatment it is easily avoided. [3] Jealousy has approximately the same origin as anger—namely, restraint or interference—but it should be considered more as a mood than as a brief explosive emotion. It is primarily social in nature, since it can be directed only toward other people. (Sometimes a feeling akin to jealousy appears when a member of the family objects to another's time-consuming hobby. A college girl once said, when her friend began to neglect her for afternoon golf and evening study, "Thank Heaven I lost him to golf, not to another girl!")

Jealousy is not inevitable. Watson describes the behavior of his older son, after the younger one had been born and was brought home from the hospital. The family kept quiet to see what his reaction would be to the sudden introduction of a baby into the household. He entered the room, and after a few moments noticed the baby nursing. He said, "Little baby." Then he took the child's hands, patted them, rubbed its head and face, and finally kissed it, all unprompted. Thus, it would appear that jealousy is not an unavoidable reaction to a younger brother or sister, as some writers have thought. Jealousy is most likely to appear

when the first child has been spoiled and made the center of attention. Merely telling the (heretofore) only child that a younger brother or sister is expected will not forestall his jealousy. This emotion, like other unfavorable ones we have studied, should be attacked earlier.

6. Controlling Adult Emotions

(A) **EMOTIONS IN THE ADULT.** In the main we have been discussing the control of children's emotions, although some parallels in adult treatment have been indicated. With children, as with the training of animals, we are faced with the necessity of regulating the situation from the outside. But adults more or less hold their fate in their own hands. The situation is perhaps akin to that when a forced change of handedness produces stammering; the forcing rather than the change of handedness was the crucial factor.

One authority has estimated that in two-thirds of all cases removal of emotions has been achieved by the individual himself, and not through efforts of an outsider. Hence the parent is not alone responsible, nor is an adult's case hopeless.

The adult has the advantage of greater maturity and balance. He should be better able to bring his fears out into the open and to conquer them by force of reason. He is in a better position than the child to realize the drawbacks of expressing fear or anger directly, and such realization should be the first step toward control. Then, too, the adult probably has a greater incentive to eliminate these emotions, since he has greater appreciation of their consequences. Finally, the motivation is within himself, not applied externally by an older person. On the other hand, the adult may conceal fear through a sense of shame and therefore have more difficulty in eliminating it. He may avoid situations which might disclose its existence, and thus virtually ensure its permanence.

(B) **FEARS BREED FEARS.** "Fears breed fears." That is an important reason why an adult should make deliberate efforts to conquer his fears and why a parent should attempt to prevent and remove them in the growing child. One psychologist has said that he regrets very much that the term "inferiority complex" was ever invented, and that he hesitates to write on the subject of fear because many people who otherwise might never experience those feelings may acquire them by suggestion. It reminds one of the apocryphal medical student who in the course of his studies became convinced that he had everything from dandruff to housemaid's knee. The person who commences by being afraid of one or two situations may begin to doubt himself, and end by being afraid of anything new, of meeting people, of losing his job, and

so on. Anger produces the same general situation. The person who is unnecessarily irritated at a few things becomes more apt to fly into tantrums at the slightest frustration.

The manner in which one person cured herself is quoted: [7]

A mother not long ago gave this significant summary of her life: "As a young woman I was troubled with many fears, one of which was the fear of insanity. After my marriage these fears still persisted. However, we soon had a child and ended by having six. As I had to do practically all my own work, whenever I started to worry, the baby would cry or the children would quarrel and I would have to straighten them out. Or I would suddenly remember that it was time to start dinner, or that the ironing had to be done. My fears about myself were being continually interrupted by family duties, and gradually they disappeared. Now I look back on them with amusement."⁸

As Link says, the moral of this episode is not necessarily to have six children, but that too much leisure is conducive to the generation of fears. Well-to-do women with servants and few genuine interests furnish the largest group of patients for psychiatrists. Because they have little to do they fall into habits of brooding, self-pity, and gross exaggeration of minor symptoms.

(C) INDIVIDUAL DIFFERENCES IN EMOTIONALITY. Half a century ago William James wrote of "tough-minded" and "tender-minded" people. We have already pointed out that fear itself is native, but the particular type of fear is acquired. No one is entirely free from fear. The tough-minded person is less susceptible to emotional shock, needs a stronger stimulus to establish a fear, and recovers more rapidly from shock. The tender-minded individual is shocked more readily and takes longer to recover. In a family of four children two became terribly frightened during a thunderstorm, while the other two actually seemed to enjoy it. Yet all four children had presumably encountered the same experiences. The man who reported the following incident from his boyhood would probably have been termed tough-minded by James.

I suppose parents have always tried to protect their children from ugliness and fear. I think that a great deal of their worry is unnecessary. Things that shock a grownup may be to the child merely matters of passing excitement. When I was a boy in New York, I saw a fireman fall from the back step of a galloping hosecart, and his leg sliced off by the wheel of the hook-and-ladder that followed. Opposite St. Patrick's Cathedral, on my way home from school, one day, I saw a liveried groom thrown from his horse, and his head instantly turned to a patch of red pulp by the wheels of one of the new Fifth Avenue buses. To a normal boy like me the excite-

⁸Link, H. C. *The rediscovery of man*. New York: The Macmillan Co., 1938, p. 99.

ment, not to mention the pleasure of knowing that I alone of my gang had seen it happen, heavily outweighed the horror. Later, when I started to give my mother the details at lunch, I was quite surprised to see her turn almost sick with horror—first on her own account, I suppose, then on mine. I remember being annoyed, too, when Annie, the maid, dropped the plate of chops she was passing and fell in a faint. I liked chops. [9]⁴

Within any given person there are differences in emotionality. One person may be afraid to be catcher in a baseball game, but have no qualms about diving from a ten-foot springboard. His friend may have just the reverse of these feelings. Possibly there is also a general level of fearing, or becoming angry, in each of us, with specific situations varying somewhat. Such variations are probably due to past experiences.

We also encounter theories that certain groups or races are more emotional than others. Southern Europeans display more emotion than Scandinavians. It is virtually certain that these differences are cultural (imitated) and socially encouraged rather than innate.

(D) CONTROL OF MOODS. Moods are differentiated from emotions chiefly in terms of their duration. Usually we are afraid for only an instant, or only as long as the situation persists, plus possibly a short additional time for recovery from the shock. We are angry only as long as we are frustrated, also allowing a little more time for the resentment to die down. But cheerfulness, gloominess, depression, excitement may persist all day or even longer. Also, moods are in general less violent than emotions.

If you get up, cut your face in shaving, find that your suit has a large stain, burn your toast, and barely miss your bus downtown, you will probably be in a bad mood for several hours. If you allow the mood to persist unnecessarily, you will become a burden on your friends and associates; you may lose customers and even your job. Can such moods be controlled? The answer lies in the individual's own determination. A person can ordinarily control his mood if he has sufficient desire. The trouble often is that he feels aggrieved and deliberately keeps the grudge alive.

While taking a trip with a friend I asked him to drive for a while. He did one or two foolish things which irritated me and caused me to sulk for an hour or two. All of a sudden I realized that I was the chief loser; I was spoiling my own fun while on a pleasure trip and passing through country with beautiful scenery. With that idea in mind I snapped myself right out of it. Since then I think of that incident every time I get into a quarrelsome or pessimistic mood.

⁴Moffat, D. The old woman. *New Yorker*, 1937. Vol. 21.

As in the case cited on page 205, activity is a fine means of recovery from an undesirable emotional state. It has been suggested that a widow who selects mourning garments is doing herself good by keeping busy and not giving herself over to grief and brooding. In such cases a temporary change of surroundings may be of assistance, so that constant reminders of the deceased person may be avoided.

SUMMARY

The emotions of the child at birth are simple and sparse. There are just a few natural fear and anger stimuli. In comparison, the adult has built a structure of derived and complex emotions upon general native stimuli, such as fear of psychic shock and anger because of physical restraint.

Some emotions are subject to maturation, since they appear when the child is old enough to appreciate and understand their causes. Most, however, are definitely learned. The principal ways in which they are acquired are: direct conditioning, imitation, transfer from similar situations, verbal learning, and learning from pictures or dreams. Emotions are very persistent; in fact, emotional memories often outlast those based upon intellectual materials.

There are a number of theories of humor, but most of the situations which provoke mirth center about superiority, surprise, and repression.

It is desirable that certain emotional expressions be inhibited or eliminated. Since many fears will not disappear by themselves with the passage of time, active steps are necessary. There are a number of possible methods for removing fears, but the best are: introducing the child to the feared stimulus by degrees, giving him an opportunity to become familiar with it, and promoting his skill with it. Such efforts must be gradual; forcing or hastening the process will probably intensify rather than remove the emotion. Anger may be controlled by causing the individual to lose something he desires or by arranging his environment so that he is free of too-severe conflicting situations.

Many emotions can be forestalled; that is, prevented in advance of their acquisition. Promoting a person's skills and enabling him gradually to become familiar with the situation will lead him to a natural acceptance without qualms.

Adults can control their emotional expressions, especially anger, and moods such as grouchiness, by their own will power. Fears may demand gradual habituation by the individual himself, in contrast to the external and indirect approaches necessary with children.

REFERENCES

1. Goodenough, F. L. Anger in young children. Minneapolis: Univ. Minnesota Press, 1931.
2. Harlow, H. F. Fear. 1937. Privately printed by author.
3. Jersild, A. T. Child psychology. New York: Prentice-Hall, Inc., 1933, 105 ff.
4. Jersild, A. T., & Holmes, F. B. Children's Fears. New York: Teachers College, Columbia Univ., 1935.
5. Jersild, A. T., & Holmes, F. B. Methods of overcoming children's fears. *J. Psychol.*, 1936, 1, 75-104.
6. Jersild, A. T., & Holmes, F. B. Some factors in the development of children's fears. *J. exp. Educ.*, 1935, 4, 133-141.
7. Link, H. C. The rediscovery of man. New York: The Macmillan Co., 1938. P. 99.
8. Lyons, E. Stifled laughter. *Harper's Magazine*, April, 1935.
9. Moffat, D. The old woman. *New Yorker*, 1937, Vol. 21.
10. Omwake, L. A study of sense of humor. *J. appl. Psychol.*, 1937, 21, 688-704.
11. Omwake, L. A study of sense of humor. *J. soc. Psychol.*, 1939, 10, 95-104.
12. Perl, R. E. A review of experiments on humor. *Psychol. Bull.*, 1933, 30, 752-763.
13. Watson, J. B. Behaviorism. New York: W. W. Norton & Co., Inc., 1930. Chapters VII and VIII.
14. Watson, J. B. Behaviorism. New York: W. W. Norton & Co., Inc., 1931. P. 174.
15. Watson, J. B. Behaviorism. New York: W. W. Norton & Co., Inc., 1931. P. 187.

XI

THE NATURE AND MEASUREMENT OF PERSONALITY

Personality is a matter of immense importance in our daily lives. Friends are chosen because of their personalities; workers are sometimes employed on a basis of personality as well as skill. Promotions are often based more upon personality than ability. If their personalities are pleasing, people are asked to join social clubs. Dinner guests are selected from those among our friends with common interests. It is said that ten times as many men are dismissed from jobs because of personality weaknesses as are fired for lack of skill. This is especially true of college graduates; they seldom lack ability but they may fail because of personality deficiencies.

1. Definitions

Personality has been defined in various ways, but the substance of the definitions is practically the same. We quote three definitions to show as many slightly different angles: (1) Characteristic modes of behavior. (2) Sum total of a person's behavior traits. (3) The habits by which one person may be differentiated from other people.

If a person is said to have a certain trait, we mean that he behaves consistently in similar situations. Thus, we may say that a certain man is characteristically a hard worker, that he is characteristically kind to his family, that he is characteristically cheerful, that he has a tendency to be absent-minded. A trait, then, is a habit which appears in a specific situation more often than not. When we say that a certain individual is honest, we mean that when confronted with a choice between honesty and dishonesty, he uniformly (or nearly always) selects the honest alternative. That uniformity is expected, is indicated by the statements "It's unlike him to do that" and "I don't believe he would ever do such

a thing." In criticizing a play, discussion often revolves about the problem of character portrayal. Would the heroine actually have said that thing or acted in that way? Did the particular speech or action fit in with the character the playwright had created?

2. The Nature of Personality

(A) **PERSONALITY IS A SOCIAL PHENOMENON.** As Young says, "The individual does not grow up in a vacuum. He is at all times reacting to a world around him, consisting of physical and organic objects, especially, of other human beings." [24] When we say that a person is honest, or cheerful, or generous, we are referring to his relations with other people. A person may show certain traits when he is alone, and a few traits seem to be individual in nature. A man may cheat in solitaire or he may become grouchy when alone in his house; a hermit may be slipshod in caring for his shack. But these exceptions are comparatively minor, and many of the traits were originally conditioned in social situations. In the main, a person can be honest, witty, conforming, independent, dominant, prejudiced, sympathetic, or vivacious only while with others.

In daily life the term "personality" is used to denote ability to get along with others. If a man makes friends easily, is tactful and courteous, adds zest to a social group, and is well balanced, he is said to have a good personality.

A word about "character" is perhaps in order. Character is often used interchangeably with personality, but strictly speaking it is not synonymous. Character refers to a part of personality, particularly to those traits which are ethical or evaluative in nature. [19] Honesty, morality, and possibly conformity may be classed as character traits. In describing personality character is taken into consideration as only one small aspect. A gang leader might have a very poor character, but he might have at least as interesting a personality as a steadfast and upright citizen.

(B) **PERSONALITY IS USUALLY INTERPRETED FROM BEHAVIOR.** Since personality is chiefly social, it is usually described in terms of action. For example, if a person is habitually late at his appointments, we set that down as a personality characteristic. Such people often plead that their tardiness was unavoidable, that they fully intended to arrive on time. Since tardiness is an established part of their social behavior, it is considered one aspect of their personality.

Certain unfavorable aspects of behavior may have their roots in physical handicaps or psychological maladjustments that are not readily apparent. A college girl acquired the reputation of being "high-hat" be-

cause she failed to speak to friends when she passed them on the street; she was actually very near-sighted but did not wear glasses for appearance's sake. She was friendly by nature, but she could not recognize people without her glasses. Some people are too shy to speak first; if they are not addressed, they will not speak at all. They may seem aloof and snobbish at a party; actually they feel shy and unwanted. Children often exhibit temper tantrums solely to attract attention, although they are not normally ill-tempered. Explanations, however, do not justify or condone unsocial behavior; outsiders see one exhibition and classify the child as an ill-tempered "brat." If a person fails to greet friends, regardless of the underlying reason, he will find himself losing popularity. If he loses his temper for any reason whatsoever, he may offend a friend. We are judged and treated in accordance with our actual behavior, since that is the way we are known to all except a few intimate friends.

(C) PERSONALITY IS A STIMULUS AS WELL AS A RESPONSE. We often speak of the individual's personality in terms of its effect on others. The terms "strong" and "weak" to describe personality have little scientific meaning, but in a limited connection we might employ them to designate persons who strongly or weakly influence situations in which they are placed. If a person joins a group and soon has the discussion directed toward *his* vocation, *his* hobbies, *his* interests, and *his* experiences, we would say that he has strong stimulus value. If another person joins the group and remains an hour without changing the course of conversation one whit, we would say that he is weak in stimulus value.

Some people are said to have a "lot of personality." Strictly, personality does not exist in terms of quantity. Only single traits or groups of related traits can be measured quantitatively. We can rate a person on a scale from one to one hundred in terms of honesty, sense of humor, willingness to accept responsibility, or initiative. What is usually meant by the phrase "a lot of personality" is that the individual stands out from the crowd. If he is a speaker, he commands a lecture hall full of listeners; if an actor, he draws more attention and interest than others; if a salesman, he clinches contracts where others have failed. What causes this is uncertain. Supernatural explanations have been put forward, such as personal magnetism. Analysis of this trait shows that it is not the same in all its possessors. Certainly Mussolini's personality is far different from that of a currently popular screen lover; yet both are said to have "a lot of personality." These traits are not necessarily desirable. Some famous criminals are more outstanding in personality traits than are many of our more conventional pillars of virtue. But whatever these traits may be, they certainly are a great asset to their possessor. A winning personality is far

more efficacious to a politician than are sound intellectual arguments. Witness the popular response to Theodore Roosevelt in contrast to that accorded Woodrow Wilson.

(D) **PERSONALITY HAS MANY DIMENSIONS.** A person's ability can be evaluated in some lines, such as intelligence, speed of work, and strength, but this is not true of personality. To begin with, there is no such thing as a "best" personality. Certain traits may be desirable in one situation and undesirable in another. A propagandist whose task it is to convince legislators of some doubtful issue would be handicapped by the same sense of ethics which would be considered desirable in a minister. A bill collector should not have the same degree of sympathy that a nurse displays. A butler should be unassuming and submissive; a real estate salesman should be aggressive and bursting with enthusiasm. Yet there are certain traits which we would agree are always desirable: tact, emotional control, trustworthiness, and neatness.

Another point is that personality has many sides. Each of us has traits in which we are rated as superior, others in which we are about average, and still others in which we fall below average. Perhaps the closest we could approach a composite rating is to say that a person has an excellent set of personality traits for his occupation, for a roommate, or for a week-end guest. We might be glad to room with a certain person for a school year, but would be unwilling to entrust our business affairs to his care. Or we might like to play golf with someone, but would not care to have him as a guest at a formal dinner. These arguments suggest another important fact: that each of us has in effect different personalities which are displayed at different times. Our general behavior, conversation, or courtesy depends on whether we are with our parents, our minister, our boss, or our school chums. We are consistently on our best behavior in the presence of certain people. This may partially account for the fact that ministers' views of people are so optimistic that their letters of recommendation mean little.

No single personality test can be all-inclusive. A personality can be evaluated only in terms of a specific situation. However, we can draw up standards of what traits are desirable and essential, and then determine whether any given individual measures up to them. Personality has many dimensions; how many, no one can say. There are possibly as many dimensions as there are traits, and lists of several hundred traits have been made.

3. Are Personality Traits General or Specific?

We can subdivide personality as a whole into a hundred or more traits, such as honesty, tact, conservatism, and so on. Does each of

these stand as a whole or does it in turn need to be broken down still further? Is a person equally honest, or neat, or tactful in all situations? Is a person who is radical in politics also radical in his views on pacifism, economics, sex morality, and religion? Can we assume that one who dresses neatly will also have a tidy room and turn in neatly written reports?

The problem of honesty has been investigated several times. The prediction that the boy who steals cookies from the jar or pennies from his mother's purse will grow up to be a bank robber or an embezzler has never been proved. Several experiments have dealt with honesty in examinations. If an examination is given to a college class, photographed, and handed back to the writers to be corrected by themselves, from a third to a half of the students will change some of their answers. Certainly, then, if these students were dishonest in other situations, there would not be enough prisons in the country to hold them! Even prospective teachers, aspirant models for youth, occasionally cheat in examinations and falsify facts on application blanks in order to secure positions. But these same individuals would not steal another student's textbook or take goods from a storekeeper's counter.

In an extensive study by Hartshorne and May, school children were placed in actual life situations in which various forms of dishonesty were possible. [4] In a written test the order of questions was changed slightly from paper to paper, so that anyone who copied from his neighbor would get the wrong answer. In another test, students were given scoring keys; any changes from the original answers, which had been recorded unknown to the student, counted as cheating. Another clever method is called the "Improbable Achievement Technique." Subjects were asked to look at a sheet of paper containing a number of small circles, then to shut their eyes and make pencil marks within the circles. Scores higher than a small chance possibility suggest peeping. Also, several games were tried. The child was blindfolded, but a slight amount of vision was purposely allowed at the lower edge. His task was to pin the tail on the donkey. Taking advantage of the small gap in the blindfold was evidence of cheating. In another game a bean relay was held; on each trip one bean was supposed to be carried from the start to a home box at the other end of the room. Trips were counted unobserved through a peephole. If there were more beans than trips it was apparent that someone had taken more than one during some trip. Stealing tendencies were studied by putting a dime, apparently by accident, among the pieces of a puzzle handed out for solution. Many other tests were employed, but those mentioned will serve as representative samples.

As a result of statistical treatment of the scores, the authors came to the conclusion that deceit was a specific, rather than a general, thing. The child who seems to copy from a key regularly may not be tempted to take a loose dime in a box, to lie to win social approval, or to cheat in parlor games. In fact, some children will cheat consistently on arithmetic tests, but not on spelling tests.

Another study of honesty and cheating is instructive. Tests similar to those of Hartshorne and May were given to boys in the Illinois State Reformatory, and the extent of cheating was compared to that in several regular high school classes. [6] There was only slightly more cheating on the part of those in the reform school, and two-thirds of the group remained honest. Also, those who had been convicted of stealing tended to cheat less than those guilty of sex offenses. Therefore, it appears that dishonesty of serious enough nature to necessitate conviction is not necessarily accompanied by improper conduct in all other situations.

Let us now approach our problem from the opposite direction. We have shown that superficially similar personality traits are not perfectly correlated. That is, they do not hold with equal force in every situation. Is it true, then, that there is no relationship at all? If, for instance, a person is aggressive in a certain situation, is this no indication whatsoever of his aggressiveness in any other situation?

Naturally, we cannot expect complete uniformity. A person is likely to be more dominant toward subordinates than toward co-workers, and he may be distinctly submissive when his boss comes around. The most fun-loving man in the world does not laugh at every joke; certain types of humor do not appeal to him at all.

This problem of generality versus specificity of attitudes was attacked by Herrick on a broader basis than Hartshorne and May's study. He measured the attitudes of several hundred college students toward problems in nine fields: law, communism, patriotism, God, birth control, evolution, constitution, capital punishment, and war. [5] He found an average intercorrelation among all these tests of $+ .24$. (For interpretation of this figure, see page 309.) This figure demonstrates only a slight positive agreement. Thus, those who are liberal toward communism are more likely to be liberal also toward evolution or birth control. However, no student was liberal on all scales, nor was anyone conservative on all nine counts. The majority were conservative on from two to four tests, and either neutral or liberal on the rest.

Herrick was interested also in studying formation of attitudes and performed a novel experiment with monkeys. He deliberately built up attitudes of success and failure and then tested their generality. After

training the monkeys to take their food from the inside of boxes with hinged lids or catches, the covers were screwed down tightly. The monkeys soon abandoned their efforts to open these particular boxes, but it was discovered that this expectation of failure did not carry over to different boxes; they attacked them as vigorously as if the discouraging situation had not arisen.

Maslow found a high degree of consistency in dominance behavior in monkeys. If two were placed in a cage, one would be dominant over the other in seizing food, sex aggression, and play activities around the cage. The dominant animal typically

- Pre-empts all or most of a limited food supply;
- Frequently mounts the subordinate animal, regardless of gender;
- Bullies the subordinate animal;
- Initiates most of the fighting;
- Never cringes under aggression; is rarely passive and almost never flees from aggression;
- Is more active and initiates more play.¹

As to whether dominance is a general factor, Maslow says that there are high correlations among sex, feeding, and aggression behavior, but that there are enough exceptions so that the three are not to be considered as identical traits. [13] This same general fact is often observed with human beings. A person who is very aggressive in his business dealings is likely to behave the same way in social and recreational situations.

Summary. Let us try to draw together the various threads of evidence on this problem. Can we synthesize the conflicting trends? At the outset we realize that traits are neither perfectly correlated nor are they entirely specific. Next, it has been suggested that traits become more general with increasing maturity. This may account for the slight differences between Herrick's findings and those of Hartshorne and May, since the former used college students, and the latter investigators tested school children. Younger individuals apply their attitudes only to the narrow situation in which they have had experience, while older persons generalize on a broader front. We have seen, in Chapter X, a parallel situation with respect to emotions. While they are in the main acquired from specific experiences, some individuals are especially prone to acquire fears, while others can go through various experiences without being shaken.

¹Maslow, A. H., & Flanzbaum, S. The role of dominance in the social and sexual behavior of infra-human primates. *J. genet. Psychol.*, 1936, 48, 278-309.

As a final warning, we urge the reader to be cautious about attempting predictions of behavior between one situation and another, even when the two are apparently similar. The correlations are so low that prediction becomes only slightly better than chance. Although there is a positive agreement in behavior among relatively similar situations, it is low enough so that attempts at accurate prediction are not possible. Acquired attitudes seem to be confined to the original situation. World-famous scientists, who are extremely critical about accepting facts in their own field, often swallow the most glaring superstitions in other fields. This has direct application to required courses, which are supposed to train in such things as accuracy and critical thinking. (For more extensive discussion of this problem see Transfer of Training in Chapter XIX.)

4. Personality and Ability

Does the brighter or more accomplished person have a more desirable personality? Technically speaking, there should be no relationship between intelligence and personality. But from a practical point of view, a person's abilities do form an aspect of his personality. If he were to choose as companion for the day one of two students, would he pick the individual who had earned high grades and demonstrated ability in outside activities or would he choose a person who was on probation and was otherwise "just another name in the directory"? The brighter person knows more, thinks more quickly, is more clever, and picks up ideas more quickly. The more accomplishments he has—tennis, swimming, dancing, bridge, or whatever—the richer a person's personality will be. In this sense, then, intelligence and ability must be considered as phases of the total personality.

Intelligence may exert an indirect influence on personality. The person who is dull and continually experiences failure becomes discouraged and embittered, and hence is not a pleasant person to have around. At the other end of the scale, *sometimes* brilliant people become overbearing, cynical, and hypercritical of others.

We must not overstate our case. Some brilliant and accomplished people are not socially desirable because of certain personality failings. A few world-famous scholars cannot find a place on any university faculty because they do not get along with people. And conversely, some of the most interesting and entertaining people are failures in business and the professions.

Finally, certain traits cannot have any direct relationship with ability. Neatness, honesty, enthusiasm, and trustworthiness are examples of these.

But all in all, we may sum up by repeating that general ability, achievements, and special attainments are aspects of the personality; they add to a person's total behavioral possibilities. The brighter and more accomplished individual has more chance to develop a desirable personality. If the duller person develops a pleasing personality he does it in spite of his intellectual shortcomings.

5. Possible Methods of Estimating Personality

There are a number of ways in which personality may be studied. Some of these involve testing, others are based upon acquaintance and observation.

(A) **OBSERVATION.** If we know a person long enough and see him in enough situations, it would seem that we could formulate a comprehensive idea of his "characteristic modes of behavior." But no one can observe a single person enough times in every conceivable situation to be able to give a complete and accurate description of his personality. The occurrence of divorce after years of marriage suggests either that a personality change has taken place or that there was a misjudging of compatibility in the first place. To describe one person's complete personality would require an exceptional expenditure of time. Hence careful study of each criminal to determine the training necessary to restore him to a socially useful life becomes impracticable.

Observation must proceed along more limited lines. For example, I play tennis with a friend once or twice a week; I know his tennis behavior much better than I know the all-around behavior of my parents, my wife, or my best friends. One person can observe completely only in a limited situation.

(B) **RATING.** A rating may be made by an acquaintance, employer, teacher. They can give accurate ratings covering the situations under their jurisdictions, but only for these situations. We behave in one way toward a friend of our own age and another way toward an older person, in one way toward a storekeeper and another toward a minister, we treat differently a business associate and a friend with whom we share our recreational activities. We impress each one differently; we might say that we are actually different persons in different situations and in the presence of different people or groups. Practical use of the rating method, say in judging an applicant from letters of recommendation, demands that greatest weight be given to those who know the applicant in situations similar to the job. A letter from a former employer is much more pertinent than one from a minister or a prominent man who is a friend of the family. A recommendation from

a teacher might be next best, because he has seen the person in a working situation.

(C) **INTERVIEW.** Prospective employers usually like to see and talk with a person before employing him. The interview may last from a minute or two to an hour, depending upon the type of position. The interviewer asks the applicant various questions, partly to obtain certain information and partly to see how he responds. This method of personality analysis has two major limitations. First, the applicant is in an unnatural situation; he may be nervous and fail to do himself justice, or he may appear to be more courteous, polite, or businesslike than he really is. In either case the interviewer does not get a correct impression. Second, many traits cannot be ascertained through a single brief interview. It may be possible to get a reasonable line on such traits as ability to express oneself, poise, shyness, optimistic or pessimistic tendencies, and a few others. But certain other traits simply have to come out as time goes along: honesty, reliability, cooperativeness, punctuality, initiative. It is weakness in these latter traits that causes the greatest majority of dismissals. There is probably no way of estimating such traits before employment, except from statements of previous employers or teachers.

(D) **CASE STUDY.** This method is used by experts to fit together all available information about an individual, from talking to him, from evidence of employers, teachers, members of his family, or friends, and from consulting records of his performances in school, at work, and possible encounters with the law. This procedure has the advantage of viewing the problem from several angles and studying the person over a period of time. It is limited by the time and energy of the case worker and the reliability of the informants. Often contacts consist only of a series of interviews; this is the usual procedure with problem cases in school, industry, and mental hygiene.

The diary may be studied, if the subject has been so considerate as to keep one. This has proved extremely useful in preparing biographies of famous people, and in some cases to discover the innermost thoughts of someone who has become maladjusted. Diaries may hold secrets told to no one. But a serious drawback to general use of this method is that diaries are kept almost exclusively by introverts. The typical extravert does not have the patience to jot down his thoughts and experiences.

(E) **PERSONALITY TESTS.** Personality tests have been developed as a sort of offshoot of the questionnaire method of making surveys. People are asked not only for facts, but for their opinions on certain

issues and for their behavior in certain situations. The test may be worded in either the second or third person, as:

Can you meet strangers without embarrassment?

Can he meet strangers without embarrassment?

Such a test may be administered by one's self or by an acquaintance.

6. Personality Tests

(A) NATURE OF THE TESTS. Before we attempt a critical evaluation of personality tests, let us give sample questions from tests of different aspects of personality. [2, 20] After completing this chapter, the reader might return to these questions and try to identify the particular phase of personality each attempts to discover, and what a "Yes" or a "No" answer suggests.

Do you get rattled easily?

Are your feelings hurt by remarks or actions referring to you?

Do you work by fits and starts?

Do things usually go wrong for you by no fault of your own?

Do you usually feel fatigued when you wake in the morning?

Do your moods often change without apparent cause?

Have you often avoided members of the opposite sex?

Do you like to work with many people around you?

Do you get discouraged frequently?

Do you indulge in daydreams?

Are you regarded as particular about details?

Does criticism disturb you badly?

Do you usually stay by a task until it is finished?

Do you like conventions?

Do you enjoy reading detective stories?

Would you rather have been Edison or General Pershing?

Would you rather be president of a club or treasurer?

Do you like to sell things?

(B) ARE YOUR ANSWERS CONSISTENT? After taking such a test, people often remark that if they were to fill it out again they would answer a great many questions the opposite way. Is this true? Although this statement is often made, there does not appear to be as much shift as supposed. In Strong's Vocational Interest Test, for example (see page 231), several groups were asked to reanswer the blank two years after the original scoring, and the totals came out virtually the same. A number of individual answers changed, but the shifts just about balanced each other, so that the total scores remained constant. [21]

(C) ARE YOUR ANSWERS INDICATIVE OF YOUR ACTUAL BEHAVIOR? This problem is a real stumbling block. The accuracy of the test depends upon the rater's honesty. This is especially crucial in a self-test. The subject is instructed to answer questions in accordance with his first impression, so that he will give his true reaction. If he thinks the question over, he is likely to put down what he considers the best or most creditable answer. If he is asked whether he prefers Shakespeare or a pulp magazine, he may indicate the more intellectual alternative, but his actual behavior may show that in the course of a year he has never read Shakespeare and that he has read a good deal of cheap literature. Similarly, he may refuse to admit that he blushes easily, that he tends to give up if a problem stumps him, or that he has difficulty making friends with the opposite sex, because such answers seem socially undesirable to him.

If a person fills out the questions in the proper spirit, however, his test ratings fit his actual personality with a good degree of accuracy. Not only are the total scores of value in diagnosis, but responses to individual items often furnish valuable information and suggest clues for further study.

At the same time, it must be admitted that personality tests are not so accurate at the present time as we could wish. We shall see later that intelligence tests agree very well among themselves and with criterion ratings. But personality is a complex function, and tests of it are more recent than those of intelligence; so personal interviews and data from other sources should be used to supplement test scores.

Now let us examine a number of tests which measure various broad aspects of personality.

7. Introversion-Extraversion

Introversion and extraversion are the best known of all the technical terms used to describe personality. In fact, these two words are often used in daily conversation by people who have never studied psychology.

(A) DESCRIPTION. The terms "introvert" and "extravert" mean literally thoughts turning inward or outward. The introvert is typically the scholar, inventor, poet, or philosopher. The extravert, on the other hand, is not so much interested in concepts and ideas as in persons and objects. He is the social mixer, the person who prefers to be with the crowd and in the center of activities. The supersalesman, the politician, the booster advertising his city, the man who organizes a card game among strangers, are all pronounced extraverts.

To furnish several definite comparisons between introverts and

extraverts, we have drawn up the following list in which most of the points will be self-evident.

BEHAVIOR COMPARISONS BETWEEN INTROVERT AND EXTRAVERT [9]

INTROVERT	EXTRAVERT
Interested in ideas	Interested in people and objects
Likes to work alone	Prefers working with others
Solves own problems	Seeks advice readily
Hides feelings	Conceals very little
May be blunt to others	Careful about others' feelings
Shy and ill at ease with strangers	Makes friends readily
Talks little about self	May be boastful
Worries; may be moody	Inclined to be carefree
Self-conscious; may blush readily	Less self-conscious
Suspicious	Trusts (and lends) readily
Radical	Conservative
Persistent and conscientious	Gives up easily; more superficial
Detailed; plodding	Less careful; impatient
Meticulous	Less attention to personal appearance ³

There are one or two traits, however, which are often puzzling on first inspection. Why should the introvert be radical and the extravert conservative? Because, wrapped up chiefly in his own thoughts, the introvert sees things in ideal fashion, while the extravert is satisfied to accept conditions as they are and tries to fit in with society as it is. Another question: Why is the introvert more meticulous? One might think that the extravert, a more social being, would be more concerned about his personal appearance. But we notice that another item lists the latter as unwilling to spend time fussing with details; as long as his shirt, tie, and suit look reasonably well he is satisfied. He isn't sensitive about his appearance. An introvert might be embarrassed if caught working about the house in his old clothes by an unexpected visitor, while the extravert would pass it off with a laugh.

(B) MEASUREMENT. To illustrate how introversion-extraversion is tested, we reproduce a few questions from Laird's inventory, which is perhaps the best known test for this trait. [9]

5. How have you acted and felt at social affairs?

_____	_____	_____	_____	_____
usually kept in background	retiring at a few affairs	let others en- tertain, talk, etc.	liked to do entertaining	usually lead

8. How have you decided upon matters of daily conduct?

_____	_____	_____	_____	_____
deliberated almost every- thing	searched for good reason in most in- stances	deliberated only impor- tant things	followed first impulse in many in- stances	usually fol- lowed first impulse

³Laird, D. A. A mental hygiene and vocational test. *J. educ. Psychol.*, 1925, 16, 419-422.

22. Have you unburdened your troubles and worries? _____ _____ _____ _____ _____
 very freely inclined to be confidential tell some troubles rarely unburden them keep all to myself
33. What kind of work have you liked best? _____ _____ _____ _____ _____
 coarse rough work rather liked manual labor not particular liked exact, delicate preferred very painstaking^a

It is especially important to point out that no one is introverted or extraverted in all possible characteristics. Even in the dozen suggestions given here you may have found some in which you registered on one side and some in which you leaned the other way. Everyone exhibits a few apparent inconsistencies. An extravert may enjoy reading; an athlete may be very introverted. But in general there is found to be a constellation of traits; the person who is highly introverted in one characteristic tends to fall toward that end of the scale in the majority of other items of behavior. The one who is at neither extreme tends to be near the middle in most of his traits. It is only when a person is well toward one extreme or the other that we can speak of him as truly introverted or extraverted. Those between are called *ambiverts*. The usual convention is to place the 25 per cent at each extreme in the two classes, and call the middle 50 per cent ambiverts. Anyone may check this roughly by thinking of a number of his friends; some may be termed as "E" or "I," but the majority do not fall into either extreme, and will thus have to be considered as ambiverts (meaning that their thoughts turn both inward and outward).

(C) PRACTICAL APPLICATIONS OF INTROVERSION-EXTRAVERSION MEASURES. Because of the differences in personality traits, the "I" and "E" types will be interested in different activities, and will give a different quality of performance in any given activity.

Let us begin by citing some examples right at home: extracurricular activities engaged in by college students. In general, we should expect the extravert to go in for social affairs and the introvert to engage in more solitary pursuits. The extravert will be desirous of joining a fraternity, of becoming a class officer, of leading a student dance, of doing things in the presence of groups of people, and of getting publicity. In contrast, the introvert will engage in scholarship, rifle marksmanship, language clubs, music, and writing for a literary magazine. Even within the same field of endeavor there may be characteristic differences. The introvert may be content with minor sports, since he is more concerned with the skill itself than with the rewards of glory and headlines. In writing for the school paper the introvert will prefer

^aLaird, D. A. A mental hygiene and vocational test. *J. educ. Psychol.*, 1925, 16, 419-422.

special columns, editorials, and reviews, while the extravert will handle news reports and managerial functions.

Certain occupations are better handled by an extravert, and there are certain others which an introvert can discharge more effectively. Typically extravert occupations are those of salesman, hotel clerk, manager, and press agent. Introverts are best at research, invention, inspection, accounting, statistics, at using delicate machinery, and at work of painstaking detailed nature. The majority of occupations, however, demand the interests of an ambivert, since duties usually call for both social relations and work of an individual and careful nature. Most office work is of this type. Lawyers and doctors have to be able to direct their thoughts either way. They have to study to keep up with the latest developments in their fields—an introvert activity—and to appear in court or cheer up their patients—demanding extraversion.

The workings of the two personality types can be seen by studying various college professors. Their duties demand lecturing and research; therefore both aspects are to be expected. But most professors prefer, and excel at, either one or the other. Some famous scholars are poor teachers and probably introverted; some excellent and interesting teachers do little research and probably tend toward the extravert end of the scale. The introvert makes the deep, painstaking scholar; the extravert who attempts scholarship tends to read more rapidly, to spread himself more broadly, and to jump to conclusions a bit more hastily than the introvert.

Careful managers decide on promotions on the basis of personality traits. Traditionally, the man who has the best production record—units turned out or sales made—is promoted when a vacancy occurs. But it does not necessarily follow that a man who runs a machine well or has an excellent sales record will make a good leader or executive. Only if he is extraverted will he do well in this capacity. If he is introverted his logical promotion should depend upon a vacancy in inspecting, designing, and so on.

The question is sometimes raised as to whether extraversion or introversion is preferable. That question cannot be answered in any final sense; any more than it can be said whether a red dress or a blue dress is better. It all depends on the situation. For some activities an extravert is better fitted; for others an introvert is preferred. In terms of social success and money-making, the extravert has an advantage. Since in most occupations success is chiefly determined by ability to handle and get along with people, cultivation of a reasonable degree of extraversion is desirable. The extravert is not necessarily happier or better satisfied with himself because of his traits.

8. Neurotic Tendencies

Some people worry too much and are oversensitive; others are rarely bothered by moods, worries, or criticisms. The following questions are among the best indicators of neurotic tendencies and are used to differentiate the neurotic from the well balanced: [10]

Do you often feel just miserable?

Are your feelings easily hurt?

Does some particularly useless thought keep coming into your mind to bother you?

Do your feelings alternate between happiness and sadness without apparent reason?

Are you troubled with shyness?

Do you worry too long over humiliating experiences?

Are you troubled with feelings of inferiority?

Do you worry over possible misfortunes?

Can you stand criticism without feeling hurt?

Do you often feel lonesome when you are with other people?

Do you consider yourself a rather nervous person?

Do you daydream frequently?⁴

Naturally the neurotic answer in each case is "Yes." A "No" answer indicates freedom from worry on that particular score.

To be considered neurotic a person would have to answer a majority of these questions in the affirmative, and to have these feelings occur frequently or persistently. Naturally all of us occasionally are upset, or daydream, or feel inferior. It is only when a feeling is constant and long continued that it becomes symptomatic. If you offend someone unwittingly and are sorry, that is reasonable; but if you lie awake nights and have your pleasure in life spoiled for weeks over some trivial incident which the other person has long since forgotten, that is neurotic.

Just as with other personality measures, a few people score high in this trait, a few at the other end are remarkably free from worries, and the majority of us have a few minor and transitory neurotic tendencies.

Here is a sample case of a highly neurotic man, quoted by Menninger: [14]

Never have I been free from a pervading sense of unreality, a feeling that things were not right, that I am only partly here and partly in some other world. I can't seem to shake this funny feeling out of my head. My life is

⁴Landis, C., & Katz, S. E. The validity of certain questions which purport to measure neurotic tendencies. *J. appl. Psychol.*, 1934, 18, 343-356.

filled with presentiments and fears. I am distressed at a thousand possibilities which never happen. When I go to bed at night, I never go to sleep until I have worried and stewed over a score of things which have happened during the day, or which I fear may happen as the result of something I did during the day. I wake up in the night with feelings of anxiety and terror. Every night is full of the most hideous dreams, in which incredible terrors and adventures of indescribable horror involve me and seem to have been brought about by me.

Occasionally I get the notion that I am going to die. I realize that this is absurd, as there is every indication that I am in the best of physical health and have no chance of dying, but I get so frightened at the thought that I see possibilities of death in every little thing. I think that something in my food may cause acute indigestion. I wonder as I wash my face if I might get some water in my ears that would give me an infection. I think of the possibility of getting wrecked on the way to work. The thought comes that the building may tumble in, or that an earthquake or lightning or some other act of God may occur that will end things. Sometimes I even look at the men in the office and think what if they might accidentally shoot me. I know such things are impossible, or at least improbable, but all sorts of such fears come to me. Then I wonder if I may have accidentally caused someone's death at some time in my life. I have actually driven back as far as ten miles to see if a car I passed at the side of the road might accidentally have been grazed by me as I drove by . . .⁵

A very common form of neuroticism is excessive worry over health, technically known as hypochondria. In some cases the individual may take it out in talking, boring his or her friends to tears. In others not merely talk, but actual behavior is neurotic. Here are two cases:

He is alarmed at rainy weather on account of the possibility of colds; he believes that dry weather is likely to promote epidemics. He fears cold weather on account of pneumonia; hot weather on account of heat strokes. He has a propensity for wearing rubbers and heavy underwear. He is anxious and suspicious of his food. He eats far too much of it and immediately regrets it. He has never been sick in his life, but is always expecting to be imminently.

This girl is constantly afraid of infection. In one three-month period she actually used a whole quart of argyrol. If she happens to get a slight cut in a gum while brushing her teeth, she paints her gums inside and out on both jaws. If she goes to a dance in a new pair of shoes, she is so afraid of acquiring a blister which might become infected that she pastes adhesive tape over her feet, regardless of appearances, as the tape can be clearly seen through her stockings. She also washes many times daily with soap such as surgeons use for antiseptic purposes.

⁵Menninger, K. *The human mind*. New York: Alfred A. Knopf, Inc., 1930, p. 121.

The reader will get a more complete understanding of the causes of these manifestations in Chapter XIII, when we shall discuss repressions, escape mechanisms, and flights from reality.

One notices that these cases, however distressing they may be to the possessor and his friends and relatives, do not as a rule incapacitate the person from vocational and social participation. All three of the cases just cited are of people earning a living, one as a businessman, the second as a newspaperman, and the third as a social worker. Any vocational unfitness would probably come more through waste of time than because of incompetence, unless the symptoms become pronounced enough to constitute definite insanity.

9. Ascendance-Submission

When two people are together, one usually takes the dominant or leading role. He customarily makes decisions, takes the initiative, and tends to force his own way when discussion arises, say as to which restaurant or movie to patronize. Ascendance seems to be a fairly general trait. Some individuals dominate practically everyone whom they meet, and are ascendant in all sorts of situations. Others remain submissive or subordinate to almost everyone, in virtually all circumstances.

According to Maslow, [11] who has made a number of studies on this subject, the dominant person describes himself as having

(1) self-confidence, (2) self-esteem, (3) high self-respect and evaluation of self, (4) consciousness or feeling of 'superiority' in a very general sense, (5) forcefulness of personality, (6) strength of character, (7) a feeling of sureness with respect to other people, (8) a feeling of being able to handle other people, (9) a feeling of masterfulness or of mastery, (10) a feeling that others do and ought to admire and respect one, (11) a feeling of general capability, (12) an absence of shyness, timidity, self-consciousness, or embarrassment, (13) a feeling of pride.

In contrast, the person low in dominance; that is, submissive—will describe his feelings about himself in negative fashion. 'I lack self-confidence.' 'I feel inferior with most people.' 'I guess I don't think much of myself.' 'I think I'd rather be like someone else if I could.' The feelings of this type are of uncertainty, lack of confidence, general inferiority, lack of pride, weakness, general admiration and respect for others rather than for themselves, a feeling of being, in a very metaphorical sense, 'below' others, of being looked down upon, of wanting to be like someone else rather than oneself, of being dominated by others, of lack of faith in oneself and in one's ability. They often feel shy, inhibited, unworthy, self-

conscious and embarrassed. Generally they cannot be said to be satisfied with themselves.⁶

Table 18 gives samples of ascendant and submissive traits, which show several definite contrasts between the two classes of personalities.

TABLE 18
SAMPLES OF ASCENDANT AND SUBMISSIVE TRAITS

ASCENDANT	SUBMISSIVE
Tries to meet important people	Is timid about doing so
Acts in accord with own desires	Yields to desires of others
Places self in position of advantage	Does not seek such a position if it would make him conspicuous
Resists even trivial violation of rights	Does not object, even if he resents it inwardly
Haggles over prices	Avoids disputes
Opposes others' ideas	Conciliates or suffers in silence

The test has not yet been standardized experimentally for vocational use, but its authors, G. W. and F. H. Allport, [1] have suggested a number of possible applications. Ascendant people are equipped for salesmanship, social work, reporting, managing organizations, executive work, and politics. Submissive people would not do so well in these pursuits, but they are fitted for writing, music, clerical and secretarial work, bookkeeping, nursing, farming, and mechanical work.

Ascendance appears somewhat similar to extraversion, and there actually is a certain resemblance between the two traits. Leaders and executives must be both ascendant and extraverted. But opposing others' ideas and resenting minor violations of one's rights are probably more characteristic of introverts than of extraverts, since the latter are more tactful and more careful to avoid hurting other people's feelings. The extravert will take the initiative, but will not stick to his original decision too stubbornly, since he prefers to compromise rather than incur risk of an unpleasant situation. [16]

10. Social Intelligence

We all know some people who get along with others splendidly and some who constantly offend people they meet. The ability to get along with others is called social intelligence. It is important both in social situations and in many occupations. Most occupations require some degree of sociability, and unless a person gets along with people, holds his

⁶Maslow, A. H. Dominance-feeling, behavior, and status. *Psychol. Rev.*, 1937, 44, 404-429.

own in conversation, and maintains his poise under difficult circumstances, he may fail to receive promotions as vacancies arise.

Several tests purporting to measure this ability have been devised. One is especially well known, but it appears to be more interesting than valid. It involves items on such socially useful traits as memory for names and faces, judgment in social situations, observation of human behavior, and social information. Two sample questions are: [15]

John does not smoke. He is invited to a smoker. If he accepts the invitation it would be best for him to:

- Try to smoke.
- Refuse politely without comment.
- Apologetically say that he has not yet learned to smoke.
- Explain the injurious effects of smoking.

True False It is natural for us to enjoy the success of a friend without envy.¹

Another test also included memory for faces; in addition there were questions on the range of friendships and degree of liking for various social activities. [3]

If a valid measure of social aptitude were perfected, we could measure the social intelligence of applicants for positions as salesmen, executives, secretaries, and others whose duties demand constant contact with people. In tests that have been given executives rate much higher than policemen, and college students who participate in outside activities make higher scores than non-participants. But which is cause and which effect is still a matter for speculation. One objection is that the tests as now composed involve too much verbal or abstract intelligence, and do not test the truly social side of the individual. [22] Finally, we wonder if social grace can ever be measured. Memorizing a book of etiquette does not necessarily make a gentleman; nor does a perfect test score guarantee social success.

11. Personality Maturity

A test has been devised by Willoughby to measure emotional maturity. [23] It is designed to estimate the sort of development mentioned in the Biblical quotation:

When I was a child, I spake as a child, I understood as a child, I thought as a child: but when I became a man, I put away childish things. (I Corinthians, 13:11)

¹Moss, F. A. Applications of psychology. Boston: Houghton Mifflin Co., 1929, p. 215.

The test contains over a hundred items, from which the following were selected to illustrate various aspects of maturity. One is said to be emotionally immature if he—

1. Is unable to take a joke on himself.
2. Is jealous if another man shows attention to his wife.
3. If games are his dominant interest, not merely recreation.
4. If he broods or becomes angry over mistakes, rather than attempting to profit from them.
5. If he becomes emotional over violations of mores.
6. If he can't accept criticism without emotion: anger or incoherence.
7. If he demands punctilious service.
8. If he assumes satisfaction of his own desires as a natural right.
9. If he drives a car with excessive speed and risk-taking.
10. If he gets drunk to avoid facing conflicts.
11. If he constantly associates with and curries favor from younger people.^a

Two major symptoms of emotional immaturity are noted: inability to accept criticism and interference with desires; doing things which are characteristic activities of younger people. We must learn to get along with people, which means giving in at least half the time, and we should learn to accept criticism gracefully. In the other type of immaturity, the individual apparently finds himself unable to compete with people of his own age on a mature level of behavior; therefore he does not cultivate associates of the same age. Some adults who choose to work with adolescents as a hobby, such as scout work, Sunday-school teaching, organizing baseball teams, do so for purposes of accumulating prestige that they cannot obtain from more mature individuals.

12. Vocational Interests

It has become evident to vocational guidance experts that the proper place to begin such guidance is in the field of interests. A large share of waking hours will be spent at some kind of work, and unless a person likes his work he will derive little enjoyment from life. Ability is really of minor importance when it comes to choosing a vocation. A college graduate has the ability to do successful work in hundreds of possible occupations, but usually there are only a few that will genuinely interest him. Since a person does not derive satisfaction from work that lacks interest, his success is likely to be comparatively mediocre unless he finds the proper vocation. Lucky is the man who finds true enjoyment in his work. An elderly lawyer once told the author that

^aWilloughby, R. R. A scale of emotional maturity. *J. soc. Psychol.*, 1932, 3, 3-36.

he did not intend to retire because he didn't know of anything that was more fun than practicing law. A college professor said that he enjoyed lecturing so much that if he were wealthy he would pay admission to the lecture hall for the privilege of teaching.

One might ask why it is necessary to test interests, since anyone ought to know whether or not he would like a certain vocation. The answer is that he does not know. Unless a person has actually participated in the work or has had the closest contact with it, he cannot be sure that he will really like the day-by-day duties involved. One girl quit nursing after one week of training, in spite of the fact that for years she had wanted to become a nurse. An engineer made fine grades in school and developed such competence that he earned several promotions; nevertheless, he quit engineering after several years and went to law school.

Strong has measured the interests, in terms of likes and dislikes, of successful men in various lines of work, and these standards are compared with the interests of students who think they would like to be lawyers, doctors, salesmen, chemists, and so on. [21] If a person's likes and dislikes match with those of people engaged in the field, it is assumed that he will really like that type of work. If he has different interests, he will be unlikely to care for the work, regardless of his abilities.

The test has 400 items, mostly answered by three alternatives: like, indifferent, dislike. Thus, a person is asked whether he would like to be an actor, advertiser, architect; if he enjoys golf, playing a musical instrument, full-dress affairs; if he likes to repair a clock, make a speech, open a conversation with a stranger; if he prefers to operate a machine or to sell it; if he worries a great deal about his mistakes; if he can take criticism without getting irritated; and others. What have likes and dislikes in these situations to do with success as a salesman? We know that people whose interests in these 400 situations do not coincide in the main with those already in the occupation specified are usually unhappy in that occupation. Certain fundamental interests, or constellations of interests, are found in salesmen, or accountants, or journalists, and if a man does not have these he will not care for the people and situations encountered by them in their daily tasks.

This interest test has been standardized for thirty occupations and groups of occupations for men and for a dozen for women. New keys are issued as standardization proceeds. The occupations are those frequently chosen by college graduates and others of a high degree of ability and education.

13. Personality Types

Much of the discussion in this chapter has centered about the division of personalities into two or more classes, such as introversion-extra-version, ascendance-submission. In daily conversation it is often suggested that people fall into one or the other of two groups, and it seems desirable to discuss this point separately. Are people either cheerful or grumpy, honest or untrustworthy, generous or stingy? Of course not. In all ranks there are people with these traits from one extreme to the other. Very few people are always cheerful, very few are never cheerful.

Spranger [18] has suggested the division of people into six types. Some of his classes overlap with certain personality traits we have discussed previously. (1) *Theoretical*: the pure scientist. To him everything is objective and impersonal; truth is the only important value. (2) *Economic*: utility above all things; hardheaded, unsentimental businessman. He will give to charity only if there will be definite returns: money, publicity, or honor. A fine example was furnished by the millionaire who offered several million dollars for eradication of a disease on two conditions: that 100 per cent cure should be shown and that the disease be caused by bacteria visible to the naked eye. It was done; the disease is hookworm. (3) *Aesthetic*: the artist; he lives in his own inner world and rebels at convention because it restricts individuality. (4) *Social*: one whose interest lies in people, for their own sake and for their good. (5) *Political*: his aim in life is to gain power over others and to control them. The practical politician is of this nature; he will resort to all sorts of means to acquire authority. (6) *Religious*: one who is interested primarily in his own salvation and in saving others.

Such a classification is interesting. We can find people who fit each of these types; we could probably find at least one example of all six among our friends. But, like other efforts at classification, it is not possible to fit everyone into one or another of these groups. If you were to draw up a list of a dozen of your best friends, you would probably find that not more than one or two would fall into any distinct class.

Still, for general and for vocational purposes, such efforts at classification are useful. If a person lies near some extreme, we can suggest certain groups of occupations for which he is suited and certain others which are not appropriate for him. If he is intermediate he should avoid activities which are especially to the liking only of people near either extreme. But in private thinking and in social conversations,

the reader should overcome the tendency to assume that only types exist.

14. Does Your Face Reflect Your Personality?

People commonly think that they can estimate personality from looking at a person's face or his photograph. Even employment managers try to judge an applicant's personality traits from the photograph which sometimes accompanies the letter of application. At least two studies have demonstrated the incorrectness of this assumption.

In one, standard photographs were taken of college students, all in exactly the same position and at exactly the same distance from the camera. These pictures were then measured carefully, by means of pinpricks punched into the appropriate spots, in all conceivable ways: distance apart of the eyes, height of forehead, distance from jaw to nose, width of cheekbones. None of these correlated with any of a number of personality traits on which each subject was evaluated. [17]

In another study the author [8] tested the abilities of experienced psychologists and vocational guidance interviewers in estimating from photographs the personality traits of strangers. We secured photographs of college men, college girls, and a group of middle-aged businessmen, and had judges rate them on eighteen traits, such as executive ability, aggressiveness, self-assurance, introversion, refinement, and tact. Their actual personality traits were estimated on the basis of intimate knowledge by one of the experimenters for at least a two-year period. All in all, the agreement between actual and estimated traits was virtually zero. Only in chance cases was there any material agreement, no one judge was uniformly accurate, and no one trait was rated accurately by all judges.

Phrenology, which was popular several decades ago and bobs up now and then even today, is founded upon the theory that bumps on the head reveal the presence of well-developed personality traits. At one time people took such readings seriously, and showed them to prospective employers, much as school grades or intelligence or personality test scores might be used at the present time. There are several insurmountable obstacles in the way of accepting phrenology. First, the resemblance between protuberances on the outside of the skull and well-developed brain areas beneath is entirely accidental. Secondly, as we saw in Chapter IV, personality traits are not localized in any special regions of the brain. Lastly, it is important to note that phrenological analyses started from both ends and met in the center. A famous man is known to have a certain behavior characteristic, and is seen to have a certain bump on his skull; therefore the shape of his skull is said to

produce that trait. But others who have that same bump do not possess that trait, and others who have the trait do not have similarly shaped heads.

Can we tell absolutely nothing, then, from looking at a person's face? Perhaps it is not quite hopeless. People who are habitually cheerful tend to have a happy expression. Those who are nervous and worried give facial evidence of their moods, temporarily or permanently. Persons who look disagreeable are often found to have ugly dispositions. Yet the majority of people do not have any pronounced mood or any special facial set. We must conclude that only in certain cases, at certain times, and for certain characteristics can personality traits be estimated from facial appearance alone.

SUMMARY

Personality is of the utmost importance in all social aspects of life, whether work or purely social activities. It is best defined as "characteristic modes of behavior."

It has several important characteristics: it is largely a social phenomenon, it is inferred from what an individual actually does, it may be considered in terms of the stimulus value of the individual's personality, and it has many sides or dimensions.

Personality traits are largely specific. There is a weak agreement or correlation in that a tendency exists for a person to be equally radical or equally conservative, equally honest, or equally emotional in all sorts of situations, but the tendency is only slight. Prediction is possible only within very broad limits, and the chances of error are rather high.

Intelligence or abilities along any line contribute to the desirability of an individual's personality, because they widen the scope of possible behavior.

Next we discussed methods and measures of personality. Each approach has certain limitations. Observation and rating are limited by the opportunity to study an individual thoroughly in appropriate situations. Interviewing is subject to the individual's nervousness and the interviewer's prejudices. Tests furnish more all-around information, but are dependent upon the honesty of the individual in rating himself.

Several of the more important measures are those of introversion-extraversion, neurotic tendencies, ascendance-submission, personality maturity, and vocational interests.

Much popular conversation and even scientific descriptions have divided personalities into types, but we have seen that such dichotomies

do not actually exist. Likewise, personality cannot be estimated correctly from photographs or facial appearance.

REFERENCES

1. Allport, G. W. A test for ascendance-submission. *J. abnorm. (soc.) Psychol.*, 1928, **23**, 118-136.
2. Bernreuter, R. G. Personality inventory. Stanford University, Calif.: Stanford Univ. Press, 1931.
3. Gilliland, A. R., & Murke, R. S. A measure of sociability. *J. appl. Psychol.*, 1926, **10**, 315-326.
4. Hartshorne, H., & May, M. A. Studies in deceit. New York: The Macmillan Co., 1928.
5. Herrick, V. E. The generality and specificity of attitudes. Ph.D. Thesis. Madison: Univ. Wisconsin, 1936.
6. Hill, G. E. Cheating among delinquent boys. *J. juv. Res.*, 1934, **18**, 169-174.
7. Husband, R. W. Applied psychology. New York: Harper & Bros., 1934. Especially Chapters III and IV.
8. Husband, R. W. The photograph on the application blank. *Person. J.*, 1934, **13**, 69-72.
9. Laird, D. A. A mental hygiene and vocational test. *J. educ. Psychol.*, 1925, **16**, 419-422.
10. Landis, C., & Katz, S. E. The validity of certain questions which purport to measure neurotic tendencies. *J. appl. Psychol.*, 1934, **18**, 343-356.
11. Maslow, A. H. Dominance-feeling, behavior, and status. *Psychol. Rev.*, 1937, **44**, 404-429.
12. Maslow, A. H. Dominance, personality, and social behavior in women. *J. soc. Psychol.*, 1939, **10**, 3-39.
13. Maslow, A. H., & Flanzbaum, S. The role of dominance in the social and sexual behavior of infra-human primates. *J. genet. Psychol.*, 1936, **48**, 278-309.
14. Menninger, K. The human mind. New York: Alfred A. Knopf, Inc., 1930. P. 121.
15. Moss, F. A. Applications of psychology. Boston: Houghton Mifflin Co., 1929. P. 215.
16. Murphy, G., Murphy, L. B., & Newcomb, T. M. Experimental Social Psychology. New York: Harper & Bros., 1937. P. 437-439.
17. Sheldon, W. H. Social traits and morphologic types. *Person. J.*, 1927, **6**, 47-55.
18. Spranger, E. Types of men. Halle: Niemeyer, 1928.
19. Stagner, R. Psychology of personality. New York: McGraw-Hill Book Co., Inc., 1937.
20. Stagner, R. The Wisconsin scale of personality traits. *J. abnorm. (soc.) Psychol.*, 1937, **31**, 463-471.

21. Strong, E. K. Vocational Interest Blank. Stanford University, Calif.: Stanford Univ. Press, 1938.
22. Thorndike, R. L., & Stein, S. An evaluation of the attempts to measure social intelligence. *Psychol. Bull.*, 1937, 34, 275-285.
23. Willoughby, R. R. A scale of emotional maturity. *J. (soc.) Psychol.*, 1932, 3, 3-36.
24. Young, K. Social psychology. New York: Alfred A. Knopf, Inc., 1930.

XII

DEVELOPMENT OF THE PERSONALITY

Personality is almost entirely acquired. Since the psychological inheritance is relatively scanty, it is possible to mold personality into almost any shape one might desire. This, in brief, is the principal point of this chapter.

1. Are There Any Innate Personality Traits?

Since a major premise of this book is that learning is far more important than inheritance, obviously our definition of personality as "characteristic modes of behavior" implies that these modes are largely acquired. But there still is a possibility that some traits are innate. These traits might be transmitted from ancestors, or they might be peculiar to the individual himself. In jest or for spite, bad traits are often attributed by relatives to the opposite side of the family tree and desirable traits are claimed for the same branch. "Like father, like son" is a common expression. "What can you expect from such a family?" is frequently heard in attempts to explain peculiarity or delinquency.

It has been suggested that single traits are acquired, but that certain broad and general ones are innate. For example, a king of England recently abdicated. One explanation of his abdication was that he could not get along with advisers. All his life efforts had been made to render him amenable to suggestion, but he had always displayed a high degree of independence and resistance to suggestion. Since this trait of independence had survived forty years of pressure from family and advisers, some regarded it as innate. Difficulty of change is one

criterion of whether a trait is innate or acquired. Let us cite another case of failure to change personality.

W's father and grandfather owned a bank in a city of a few thousand. It was considered a family institution, so W was subjected to constant pressure to make him take an interest in banking. It was discussed at home, and he was forced to work in the bank during school vacations. At the university he was pressed into majoring in commerce, although his true interests lay in music, and he took as many elective courses in the school of music as possible. After graduation he dutifully went to work in the bank, but without interest and enjoyment. Two or three years later, during the depression, the bank failed. Now W earns his living in aesthetic lines, which are more in accord with his interests.

Even if specific and well-developed personality traits are largely acquired, there may still be innate predispositions to behave in one way rather than another. Some traits may have a certain biological basis in structure, available energy, health status, or glandular balance. For example, a healthy person tends to display leadership qualities and the less energetic individual to become submissive.

In some instances traits have appeared early and remained consistent. Some infants pay unusual attention to people around them and years later are found to have developed extraverted tendencies. At four months one child was noted as inclined to "ready easy laughter," and at eight years was rated by his teacher as possessing an "unusual sense of humor; average amount of laughter." Another was described at four and at twelve months as "mischievous" and making "many inventions of games"; later at six and eight years he was "imaginative in play; very fond of stories" and "markedly original in content of drawings; amusing detail." Such persisting traits might be considered native, although we realize that there is a source of difficulty in that not much personality can be displayed before a person acquires locomotion and speech. Therefore some habits which are apparently innate may easily have been acquired in the early months. [1]

At the same time, we should be extremely cautious about crediting heredity with traits which appear to be unlearned. For example, drunkenness and criminality are often said to be inherited, but the example of elder members of the family is almost wholly responsible. One instance of imitation is described in this quotation:

If my father could watch my son for a while, he might realize his own immortality. He would be amused to see Pete, a child of six, wave his hand in the identical gesture my father made to indicate that a questionable assertion of his was obvious or final. When I first noticed it, I called it an inherit-

ance direct from him until my matter-of-fact wife showed me that I had the same wave and used it in saying that I didn't.

Since the young child's personality is unformed, it is natural for him to acquire traits and attitude by force of example. When a child visits another family for the first time, he is often surprised to find customs at variance with those of his own family. To sum up, heredity possibly sets a broad original tendency, but environment varies the final pattern of personality within wide limits. Pressures from family, other associates, community standards, and environmental circumstances are largely responsible.

The personality is also formed by the treatment one receives as a youth. Criminologists have long insisted that harsh treatment of juvenile offenders serves only to create hardened adult criminals. In other words, if you treat a person as a criminal, he is likely to become one. If a young man is ordered about as if he were an immature adolescent, he will probably act like one. Somewhat the same forces apply to physical traits. If a person who has suffered numerous illnesses or a crippling accident hears his problems discussed by well-meaning but ill-advised friends, he is likely to develop hypochondria. Similarly tall or short, thin or stout, handsome or homely persons may have these characteristics dinned into their ears so much that they eventually develop personality traits popularly assigned to such people.

2. The Glands

Within our body there are a number of little bodies, called the "ductless glands," which secrete into the blood stream minute quantities of potent chemicals. [5, 6] These secretions are internal, as contrasted with external discharge from the eliminative, salivary, or sweat glands. As long as they function normally we are scarcely aware of their existence, but too little or too much secretion may produce abnormalities of energy output, sex development and function, and skeletal proportions. We shall treat only those effects which have some bearing on behavior. Let us remark at the outset that the functions of these internal glands are extremely complex and that new discoveries are constantly being made.

This chart illustrates the general outline of the human body and the approximate locations of the most important ductless glands.

(A) **THYROID.** Perhaps of greatest significance to the psychologist is the thyroid gland. It lies on each side of the trachea, about an inch above the collarbone, and in the popular mind is linked with goiter.

The secretion, thyroxin, is two-thirds iodine, and has much to do

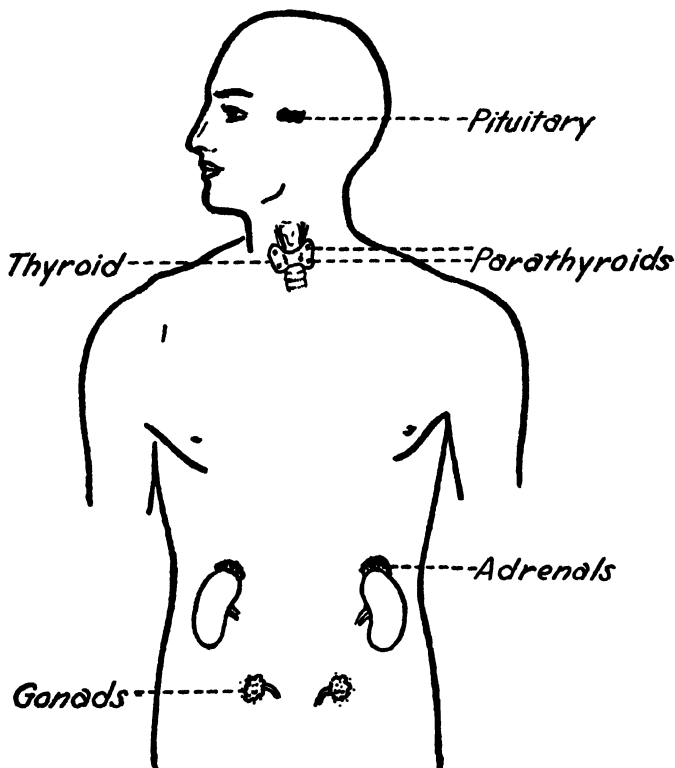

FIG. 34.—Location of the Principal Glands Which Influence Behavior.

with the output of bodily energy, or metabolism. If the thyroid gland produces too much thyroxin, an oversupply of energy will be available; if too little is secreted, the patient feels sluggish and fatigued. Simple goiter, seen in extreme cases in the form of a huge swelling on the neck, occurs when the gland enlarges to compensate for an iodine deficiency.

Among psychological effects of *hyperthyroidism* ("hyper" means excessive) are extreme nervousness, irritability, inability to sleep or relax, and loss of weight. In extreme cases the heart may be affected. Cure consists in surgical removal of a portion of the gland. Evidence from extreme cases suggests that many people are within the normal range, but have a slight excessive secretion. These people are especially energetic, impulsive, restless, require less rest than the average person, and are inclined to be emotionally expressive.

If the thyroxin is deficient, a condition known as *hypothyroidism*, the individual will be sluggish physically, dull mentally, and often depressed emotionally. If the disorder starts when he is well grown it

can be corrected by taking thyroid extract obtained from animals. If the extract is not taken for several weeks, the individual may again become sluggish and drop in intelligence. The disorder is more serious if it starts in early childhood or previous to birth. The condition is then known as *cretinism*, and only partial correction is possible. Such a person is not only sluggish and mentally deficient, but has marked physical symptoms: dwarfism, stubby hands and feet, low blood pressure and subnormal temperature, scanty hair, and sexual underdevelopment. The earlier the condition is recognized and treated the closer to normal the individual can be brought. If the condition appears in the adult, it is called *myxedema*.

Thyroid deficiency resulting in goiter is prevalent in certain sections of a country and almost totally absent in others. In general, inland districts are most affected. Well-known areas are near our Great Lakes, especially in Wisconsin and Michigan, and eastern Washington; in the Alps and Himalayas. Iodine is especially plentiful in sea foods. These foods reduce possibility of disorder; even the drinking water near the ocean contains more iodine. Iodized salt is produced for use in inland regions. Only a small quantity is necessary to bring a person up to normal. In fact, one test demonstrated that iodine added to water in the ratio of one to one million would prevent goiter in brook trout.

(B) PARATHYROIDS. These are four small glands, two on each side of the trachea, lying on the thyroid gland. Their chief function seems to be to regulate calcium metabolism. If they are removed, as sometimes happened accidentally in the early days of thyroid surgery, normal muscular tonicity rapidly turns into convulsions, and death usually follows within twenty-four hours. In spite of their immense physiological value, there are no known psychological effects from the functioning of these parathyroid glands.

(C) PITUITARY. This gland is located at the base of the brain, above the roof of the nasal passage, quite inaccessible for surgical treatment. Disorders of growth are the most spectacular effects of malfunctioning of this gland. Too much or too little secretion of the anterior portion results in gigantism and dwarfism. Giants may grow to as much as eight or nine feet in height; some dwarfs are well under three. Whether the minor differences in height among ourselves and our friends, within normal limits, are due to varying secretions of the pituitary gland is open to debate.

Not all cases are alike, but let it suffice to point out several different effects. If the gland begins to secrete too much in adult life, the skeleton can grow no more, but the condition of *acromegaly* will result. Bones of the hands, feet, jaw, nose, and even the whole head will

enlarge, causing coarse features and sometimes such pressure that terrific headaches and disorders of vision ensue. There may be accompanying changes in temperament associated with acromegaly: moroseness, absent-mindedness, inability to concentrate, outbursts of anger.

Dwarfs are not all alike. Some are "true," that is, they are small but well proportioned. Others have normal heads and bodies but very short legs. In the latter case the cartilage failed to turn to bone. Often they remain sexually immature: their voices do not change, they have no growth of bodily hair, and are incapable of procreation. However, some midgets have produced normal children. Many dwarfs are dull mentally; while giants are usually of average intelligence.

Malfunctioning of the posterior pituitary results in characteristic deposition of fat about the body. Such cases are easily identified when one sees an individual who is tall, long-legged, broad, fat, and awkward in gait and movements. This condition may originate before or after puberty.

A third general class of pituitary effects is in sexual development. This also lies in the posterior section of the gland. Cases of abnormally early puberty—some have been recorded as early as the fourth year—may be caused by an overactive gland. Conversely, sluggish glands sometimes cause delay or loss of sexual functions. This gland also seems to regulate milk secretion in mammals. Injection, even in virgin animals, has produced oestrus and lactation. Removal results in inability to lactate and loss of maternal interest. This latter is especially interesting to the psychologist, since it demonstrates a relationship between a glandular function and an aspect of behavior which is often termed an instinct.

(D) **SEX GLANDS, OR GONADS.** These glands not only regulate reproductive functions, but they also exert influence upon a number of secondary characteristics. These latter are most pertinent to us, since certain personality traits are involved. It is these glands which cause a man's voice to become deeper at puberty and a woman's to become richer, the pelvis of the woman to be larger than that of the man, the deposition of the slight layer of subcutaneous fat (which among other things permits women to swim longer in cold water), the heavier musculature and the growth of facial and bodily hair on men.

Removal of the glands results in a reversal of sexual characteristics. Men's voices become high-pitched and they become less aggressive. Their bodies become soft and fat. Women may grow facial hair and their voices tend to deepen. The same occurs in old age. These facts suggest that men and women are not absolutely distinct organisms, but that they have common elements in respect to glandular secretions.

This is borne out by a recent discovery about the disease hemophilia, a disorder in which the blood fails to coagulate. It appears almost entirely in men, and it has been discovered that an injection of ovarian extract will alleviate it. Therefore, we may deduce that most men receive a very small ovarian secretion and that its absence causes hemophilia. There is evidence that certain glandular secretions are common to both sexes and required by each for the maintenance of health, but the nature of these secretions is still under scientific investigation.

(E) **ADRENALS.** Since we have already studied these glands in Chapter VII, we need merely mention them here with the other glands of internal secretion. The adrenals are of great importance during severe emotional stress.

There are several other glands which are of less importance to us in psychology. The liver stores blood sugar, which is released by the action of adrenalin in emotional states and is of great value in producing rapid energy for violent exertion. Another gland, the pancreas, is of wide interest. This secretes insulin, a regulator of the sugar content of the urine. If this fails to function properly, the person suffers diabetes and has to take insulin regularly.

(F) **INTERDEPENDENCE OF THE GLANDS.** We have given a much simplified description of the chief functions of each gland. It is virtually impossible to separate and isolate these functions. Just as each part of a watch must be in order for the whole to run properly, so must our glands maintain their delicate balance. If we remove the thyroid, for example, the chemical balance of the entire organism may be upset to such an extent that the other glands will not function properly. There is also an overlapping of function. Excessive obesity or thinness can be produced by at least three glands (thyroid, pituitary, and gonads), and sexual malfunctions may have their root in one or more of the same three.

3. Body Build and Personality

For a long time men have tried to judge personality by physical structure: size, weight, complexion, and/or facial dimensions. [10] We discussed claims for the latter at the end of the preceding chapter. Most of the other efforts failed to produce any results or led to very tenuous conclusions. In some cases there are trends in the form of slight differences between averages, but these trends cannot be applied to any given individual with much better than chance success. For instance, it has been found that executives—governors, mayors, bishops, directors of companies—are heavier than the average of men. But we cannot say

either that any large man is bound to become a leader or that every single leader is large. Just as the biggest boy usually becomes captain of the team, so may a large man attract attention and be chosen foreman. The responsibility of the job may then cause him to develop executive ability, but mere size by itself does not.

Complexion has no effect upon personality traits. Maybe gentlemen prefer blondes, perhaps blondes are more desirable as chorus girls, but the preference, if any, is aesthetic, not scientific. Yet quacks often tell people what occupations they should enter, whom they should marry, how to be a successful salesman, on the basis of hair and skin coloring. One charlatan claimed that blondes are positive, dynamic, aggressive, and variety loving; while brunettes are negative, static, conservative, submissive, cautious, and specializing. This statement was demonstrated to be wholly without basis in an experiment by Paterson and Ludgate at the University of Minnesota. [11] They asked each of 94 judges to rate two decided blondes and two pronounced brunettes of their acquaintance in terms of those traits. There were never more than a few percentage points of difference between the two groups in any of the traits.

A spectacular study has been reported by an Austrian psychiatrist named Kretschmer. [7] He noticed that certain types of clinical abnormality tended to occur in people with certain body builds. For example, the asthenic—a person who is tall and thin, long legged, and narrow chested—tended to suffer from dementia praecox (otherwise termed schizophrenia). This disorder is a sort of exaggerated introversion; the patient shuts himself off from his surroundings and displays an almost complete lack of emotion. On the other hand, persons with a manic-depressive psychosis tend to be fat (the pyknic build). In this disorder there is an excess of emotion: one changes from extreme joviality to extreme gloom.

Two important questions come up in connection with Kretschmer's findings. First, are the results of this one experiment valid? Second, will they apply to normal people as well as to those in institutions? As to the first we cannot be sure. Some investigators have duplicated his findings; others have not. [3] The second question may be answered in the negative. The author tried to answer this question with tests of college students. There was a slight tendency for those of extreme asthenic build to be more introverted and more neurotic, and for extreme pyknics to be extraverted and free from neurotic tendencies, but that is all. [4] The reader is warned not to get the idea that all thin people are bound to become victims of dementia praecox, or that all fat people will suffer manic-depression. Kretschmer's work

started with people who were already unbalanced. Our study used normal people and attempted to see if those of certain builds had slight personality predispositions.

In everyday life we observe that certain physical limitations influence personality in a broad way. A person who is scarred or believes himself to be ugly may shun society and become introverted. One who is clumsy may not be able to develop certain socially desirable skills, such as dancing, tennis, and swimming.

4. Personality Training Must Be Started in Infancy

Learning starts as soon as the individual is born, and the same is true of personality. Molding of the personality should start as soon as it begins to develop, immediately following birth. There is important psychological justification for this: unlearning is much harder than learning. It is easier to teach a child socially desirable habits before he has formed any habits than to remove undesirable habits and substitute correct ones. Some parents allow the child to "run wild" for a few years, and then, about the time he is ready to begin school, try to "civilize" him. Some of the so-called modern schools similarly allow the child to "express himself" and develop naturally without enforcement of discipline. Either procedure often results in the child's becoming self-willed, selfish, uncooperative, and disobedient. The working world does not tolerate unlimited self-expression; we must give as often as we take. A child's potential habits are as plastic as modeling clay; a little care exercised early in life will save a lot of grief later.

Watson's widely quoted statement on this topic stirred up a great storm of discussion.

Give me a dozen healthy infants, well-formed, and my own specified world to bring them up in and I'll guarantee to take any one at random and train him to become any type of specialist I might select—doctor, lawyer, artist, merchant-chief, and yes, even beggar-man and thief, regardless of his talents, penchants, tendencies, abilities, vocations, and race of his ancestors.¹

One point would be intensely disputed. When we deal with the topic of Intelligence, we shall see that ability is largely innate and that only a certain percentage of children can become professional men or women. However, there is much more to be said for Watson's contention concerning the molding of personality and interests.

Training the personality has two chief purposes: to fit the individual

¹Watson, J. B. *Behaviorism*. New York: W. W. Norton & Co., Inc., 1930, Chapter XII.

for adequate social living, and to develop his interests along desired educational, recreational, or vocational lines. As to the last, it is more desirable for each person to select his life work from the occupations that appeal to him. The same applies to outside interests. As to the first objective, certain approved ways of behavior should be cultivated if one is not to be a social blister and a bore.

The validity of these arguments is recognized empirically by European dictator governments which instill attitudes concerning their own aims and methods in preadolescent children. In this way the youth can be brought up to hold certain beliefs concerning government, politics, economics, and war. Whether or not this training is ethical, it is psychologically valid.

5. The Personality Grows

(A) CHANGES WITH AGE. It is trite to point out that habits and interests change as we grow older. An attempt to measure this was seen in the "Emotional Maturity" test. One evidence of personality growth is the fact that a person's close friends are almost always around his own age. College students feel that high school pupils are "kids," college graduates find college students rather youthful, and those of forty-five prefer to associate with others of the same general age. We can have friends of all ages, but those with whom we have the most in common and with whom we spend time most pleasurably are likely to be within a few years of our own age.

The primary interests of people at various ages are a crude index of their dominant personality traits. Just as in *Green Pastures* the Negro's idea of heaven was represented as a perpetual fish fry with "ten-cent seegars," so we find the boy of ten wishing for perpetual marble games, one of fifteen for baseball, one of twenty for dances, and a middle-aged man for card games or vacations at a quiet resort.

Therefore, we might ask: Is personality subject to maturation like motor coordination, emotions, thinking, and other psychological traits? It is quite probable that this is true. For growing children no simple answer can be given, since school environments frequently change and children's activities are largely planned for them. During adult life, however, conditions remain relatively constant. A man may live in the same house and work at the same job from the time he is twenty-five, but his interests change. He becomes less interested in strenuous physical exertion, in going out evenings, and in taking long trips during vacations. He becomes more interested in quiet visits with old friends, in reading or collecting various objects, and in spending vacations quietly at the same place year after year.

(B) TRAINING. Constant adjustment is necessary to keep up with the environment in which one grows up. The child should be taught to make these adjustments for himself. Since it is obvious that he cannot be taught to anticipate every situation, he should be trained in self-reliance. Oversolicitous parents may make a child so dependent that he will always vacillate until someone decides his problems for him. Here is one such instance:

A girl at the age of 21 was completely helpless and had to ask her mother to make every decision for her, largely because the mother had always done so, and had never let "daughter" attempt to think for herself. When she went away to school, her mother wrote her at least one, and often two or three, letters a day, containing not so much news from home as what to do if certain situations arose.

Is it any wonder that the girl could not think for herself? She never had a chance, for her mother encouraged her immaturity. What seems to be self-sacrifice and sympathetic interest may actually be misguided direction. We have to make our own mistakes, profit from experience, and learn for ourselves. It is possible so to protect the child from falling into dangers that he does not realize they exist. The child becomes spoiled by expecting to have things done for him, by receiving solace for minor misfortunes, and by being allowed to do whatever he pleases. As an adult he may still manifest what are termed "infantile reactions." He is unwilling to assume responsibilities, becomes unduly upset over being crossed, and whimpers at slight injuries. It is not an easy task for a parent to decide where helpful guidance ends and where interference with a child's personality development begins.

In contrast to the above case, consider this one: [14]

. . . By the time I was 11, I had made extensive bicycling tours through England, entirely alone. Once I stayed away for a week and nobody knew where I was or seemed to care much. Though I made friends with anybody, nothing untoward ever happened. My worst experience was when I spent my last penny on a pair of passionately desired brown shoes and had to ride 50 miles with only a boiled egg for nourishment. I was an inveterate theatergoer, and one well-remembered week I attended six performances in London. I went alone, and let myself into our house with my own latchkey. At 14 I was given £ 100 and a return ticket to Norway. But finally, under the spur of conventional disapproval, my father yanked me back into childhood. On my return from Norway, I was sent to a finishing school, where I was considered incapable of crossing a road unchaperoned. To the three years spent there I owe the best part of my subsequent mistakes and weaknesses.²

²Wylie, I. A. R. Here and now; a word to parents. *Read. Dig.*, Feb., 1937.

Parents, especially of the so-called upper classes, often coddle their children too long, and instead of equipping them to face the world effectively, actually prolong their infancy. Child psychologists have unearthed an interesting fact from studying the development of habits in children in different economic circumstances. Those from the poorer classes and from families with many children learned to dress themselves and to care for other simple needs at a much earlier age than children in families able to afford nurses or where mothers spent more time giving routine assistance.

Personality development is profoundly affected by changes within the child's home environment. Some of these changes are: birth of a new child and consequent neglect of the first-born, a dislike for the child, or a clash of personalities. Antagonisms of this sort may manifest themselves in certain personality traits in the growing child. He may become bitter toward people and toward life in general, he may compensate for his inferiority feelings by being overaggressive, or he may lapse into fantasy fulfillment of what has been denied him.

All this brings up a baffling topic, the role of parental love. From the standpoint of objective science, parental love is virtually impossible to evaluate. Whatever the essential factor may be, we know that the best personality development takes place when both parents are living and when harmonious relations exist within the home. If one or both parents are deceased, if a separation or divorce has occurred, or if there is constant bickering and quarreling, there is a tendency for a higher rate of juvenile delinquency to occur and the child's outlook on life may become warped. Note that we do not say that development of normal personality cannot occur; we merely state that the chances are reduced.

(C) MALLEABILITY OF HUMAN NATURE. There is an old saying that "You can't change human nature." Human nature may be modified only with great difficulty after it has once become established, but at the beginning it can be molded into virtually any pattern desired. Some of the best data on this subject have been furnished by anthropologists studying primitive peoples. Maslow [8] writes:

The most amazing single fact confronting the psychologist when he deals with cultures comparatively is that so many different ranges and kinds of behavior are not only possible but actually extant. New individuals born into any cultural group in most cases fit into the cultural demands easily, i.e., conform easily to any standards or social norms already present in the group, no matter how "queer," or "weird," "abnormal," or "unnatural" they may seem to us.⁸

⁸Maslow, A. H. Personality and patterns of culture. Chap. XXII in "Psychology of personality" by R. Stagner. New York: McGraw-Hill Book Co., Inc., 1937.

Margaret Mead collected some remarkable valuable and fascinating data in New Guinea which suggest that the personalities of the sexes are entirely conditioned, and in no way dependent upon anatomy or physiology. [9]

We found the Arapesh—both men and women—displaying a personality that . . . we would call maternal in its parental aspects, and feminine in its sexual aspects. We found men, as well as women, trained to be co-operative, unaggressive, responsive to the needs and demands of others. We found no idea that sex was a powerful driving force for either men or for women.

. . . Among the Mundugumor both men and women developed as ruthless, aggressive, positively sexed individuals, with the maternal cherishing aspects of personality at a minimum. Both men and women approximated to a personality type that we in our culture would find only in an undisciplined and very violent male. Neither the Arapesh nor the Mundugumor profit by a contrast between the sexes; the Arapesh is the mild, responsive man married to the mild, responsive woman; the Mundugumor ideal is the violent aggressive man married to the violent aggressive woman.

In the third tribe, the Tchambuli, we found a genuine reversal of the sex-attitudes of our own culture, with the woman the dominant, impersonal, managing partner, the man the less responsible and the emotionally dependent person.

These three situations suggest, then, a very definite conclusion. If those temperamental attitudes which we have traditionally regarded as feminine—such as passivity, responsiveness, and a willingness to cherish children—can so easily be set up as the masculine pattern in one tribe, and in another be outlawed for the majority of women as well as for the majority of men, we no longer have any basis for regarding such aspects of behavior as sex-linked.⁴

Some individuals deviate from the pattern, and in spite of pressure fail to conform to group standards. Mead says that among the Dakota Indians boys from the age of five or six are constantly told not to display fear, timidity, or a desire to play with younger children or with girls. Boys who depart from this pattern of conduct are subjected to considerable social pressure; yet some never win the struggle for masculinity. These finally give up the effort and assume clothes and occupations of women.

6. Environmental Pressures

Our personalities are molded by imitation of those around us: members of the family and especially parents, playmates, friends, members

⁴Mead, M. *Sex and temperament in three primitive societies*. New York: William Morrow & Co., 1935.

of our social set, fellow workers, people living in our part of the country, and those of our own sex, race, and religion. Some habits are taught deliberately, but most of them are learned through observation; in other words, through the environment.

What is the meaning of "environment"? Environment includes our family, the community in which we live, climate, and various other pressures which operate upon us. But there is also the internal environment to be considered; this includes whatever happens within us from physiological changes. Being subject to chronic colds or anemia, or being crippled, may be a more important determiner of personality than having a "bossy" aunt living in the house. An accident may produce a strong and lasting emotional conditioning and make a person differ from his brothers and sisters.

Therefore, it should not be assumed that children brought up in the same household have identical environments. True, since they have the same parents and other relatives, their external environments are similar. However, if their ages are more than a year apart they attend different grades and have different companions. Different experiences, accidents, and diseases happen to each. Even twins have different environments. Informal reports about the famous Dionne quintuplets say that they have quite different personalities, even though they have had environments which externally are as identical as any children ever had.

(A) FAMILY INFLUENCES. Kimball Young [15] points out:

At the outset the infant is thrown upon the care of his family. The family is the basic social group. In it the biological, psychological, and sociological forces meet in giving the individual his start in life. The family is more than a legal formulation. Functionally considered, it is a unity of interacting personalities. . . . It is now generally recognized that one's major personality characteristics are usually determined before one is five years old, and some writers say as early as two or three.⁵

The earliest major determining influence is the mother. During the first five or six years the father is of far less importance, since he rarely sees the children except for an hour or two in the evening. Care and protection come first, and precede advice, guidance, and social assistance. It is no wonder that the mother occupies the more sentimental place in our culture. It may be, too, if we could measure these factors, that children absorb more of her personality characteristics, likes and dislikes, attitudes, and modes of behavior than the father's!

The predominant mood of the mother is adopted by the child: if she

⁵Young, K. *Social psychology*. New York: Alfred A. Knopf, Inc., 1930, p. 237.

is happy, the child adopts that state of mind; if she is inclined to be grouchy, petulant, and upset over trifles, the interaction between the two personalities is likely to result in similar behavior on the part of the child. Of course the mother, through her own behavior and by deliberate teaching, can inculcate desirable habits: self-reliance, conciliation with others, acceptance of responsibility, neatness.

(B) **BIRTH ORDER.** The presence of more than one child in the family complicates the problem. The first-born has been "king" for perhaps several years. The second child naturally receives all the attention because of its helplessness and novelty. The older child may acquire an acute jealousy. This can be forestalled, it has been found, not so much by preparing for the coming of a new child, but by previously training the older to be independent. If he is not used to being the center of all attention, he will not resent another youngster.

The only child is traditionally supposed to be spoiled. Because all affection is directed his way he tends to become self-centered. Also, he may be overregulated and consequently fail to develop self-reliance. As a third possibility, he may be forced to play alone and so develop an unusual degree of self-reliance and imagination. All these divergent influences are so variable that no standard pattern is discernible. Tests of large numbers of children occupying various rank orders within the families fail to disclose consistent trends. [12]

The youngest child often encounters another problem. Since he is the youngest, he may be called "Baby" or "Babe" for years—a name symptomatic of the treatment he receives. His psychological infancy is thus greatly prolonged. Parents seem afraid, without admitting or even consciously realizing it, that they will be thought old if their youngest child is married or holding a job of his own; hence they contrive to keep him (or her) at home long after he should be independent. Treatment of the younger child during growing years may vary. In some families the youngest is unduly spoiled; in others he feels handicapped by his size and lack of proficiency, and thus develops inferiority feelings.

It has been observed, partially in jest, that the only possible normal child is one born in the middle of a number, since the only child, the oldest child, and the youngest child have favorable influences at a minimum. Naturally, however, we realize that in no case are such tendencies as we have just described necessary or unavoidable. In the majority of instances they do not occur. With application of a little foresight the pitfalls into which many parents fall can be avoided.

(C) **GROUP PRESSURES.** From the time the individual starts school until death or invalidism removes him from society, he is subject to all sorts of influences apart from his family: neighborhood, school, church,

social clubs, and business associations. The church affords an excellent illustration. The great majority of youngsters adopt without question their parents' church and absorb its particular beliefs, not, as do adults in deciding about membership in a social organization, because they decide rationally that its tenets are better than those of another sect. Therefore, the person's views for many years, possibly all his life, are determined by that sect's stand on religious, ethical, and social issues.

The great majority of people also adopt the political party of their parents. As school children they first become aware of elections, but are not mature enough to understand the real issues; hence they may be impressed by abusive remarks heard in a heated campaign. A little girl once wakened her parents in the middle of the night, screaming because of a horrible nightmare and crying out, "The Democrats are after me." One can imagine what the conversation in the family circle must have been, and also what her adult attitude toward that political party might be.

Group pressures include what are sometimes loosely called geographical influences. Among geographical influences are those of climate, humidity, and altitudes. However, social influences really operate independently of physical surroundings. Without going into detail concerning personality differences, we may merely indicate the presence of contrasts as seen in North versus South, East versus Middle West, urban versus rural, pioneer regions as compared with long-settled districts. Just what forces have produced these general behavior traits we must leave for the sociologist to analyze. Psychologists are content to note that the individual who is reared, or even spends years as an adult, in these various regions takes on their prevailing attitudes.

(D) ATTITUDES. Attitudes are conditioned in us especially by parents, elders, teachers, and newspapers. We acquire attitudes on such topics as respect for elders, Sunday observance, courtesy toward women, feelings toward those who use or do not use liquor, and even on such personal issues as avoidance of charge accounts or formality of dress during family meals.

A college freshman who came from a home where financial obligations were treated, to say the least, with carelessness, pledged a fraternity. Temporarily unable to pay initiation fees, he signed a note, but told someone that he could not be forced to pay it, since he was under age when he signed the note. When his friend remonstrated with him that, apart from any question of legality, he shouldn't consider doing such a thing to a social organization of friends who called each other "brother," he appeared surprised. Nothing in his past family situation had instilled in him a sense of social obligation.

Prejudices formed in youth are usually quite tenacious and extremely difficult to change. Persons who grew up in a strict community cannot see women smoking without a disagreeable shock, and they even feel guilty if they take up social card playing. Similarly, stereotypes of a bomb-throwing Russian, a guitar-playing Spaniard, a cigar-smoking prize fighter's manager, the "blue-nosed" reformer are acquired. Attitudes are built up deliberately through propaganda and advertising. Hatred of an enemy in wartime, preservation of health through using certain foods, improving social status by using deodorizing soaps, and attitudes for or against certain political parties are examples.

(E) SEX DIFFERENCES. When sex differences are subjected to actual measurement they are discovered to be far fewer than is commonly believed. Extensive efforts on the part of Terman and Miles [13] did disclose *a few* personality differences, but compared with the vast number of possible differences the absence rather than the presence is impressive. Of those which do exist only a few originate in biological and glandular differences. The vast majority are acquired through social pressures. Girls are trained to make themselves less conspicuous, to be more introverted and submissive, and to follow rules (customs, directions) more closely than boys. Men are more extraverted, a fact easily explained by their greater participation in outside activities.

The interests of the two sexes are well shown by the leading subjects of conversation. [2] Men talk mostly (in order) about money and business, other men, women, amusements, and sports. Women talk about other women, men, clothes, amusements, and their immediate surroundings. The chief differences were that men discussed business and sports, and that women talked about other women and clothes.

For instance, there is no convincing evidence that women are innately more interested in children. Girls, long before their teens, are encouraged to play with dolls, to play house, and to avoid rough sports. On the other hand, a boy who might be interested in dolls is discouraged and pressure is brought upon him to play football and baseball. In this connection, the reader may wish to refer to the parallel discussion of Mead's findings about formation of masculine and feminine personalities in various primitive communities (page 249).

(F) RACE DIFFERENCES. Like sex differences, race differences are almost entirely acquired by the individual during his lifetime and are not handed down through the germ plasm. Most psychologists believe that a Negro, an Eskimo, and a Tibetan boy brought up in New York City would take on the same personality characteristics and attitudes as local boys.

Modesty in bodily exposure furnishes an excellent example. In Japan railroad passengers change to clean clothes in the aisles just before arriving at their destination. In the United States men wear trunks only while bathing, while in British countries men still (or did up to a year ago) wear the full suit. In Bali women wear only a skirt, while in India a high-caste Hindu woman is disgraced if anyone but her husband sees her face.

Several other differences between races are clearly acquired. The British are more reserved than Americans; the Britisher feels that his privacy is violated if he is asked his name, business, or plans. Yet when two Americans meet they almost invariably announce their names, businesses, and destinations. Customs are sometimes loosely thought of as inherent in a race, such as bullfighting among Spaniards, vendettas among Sicilians, group singing with Ukrainians, and restaurant owning on the part of Greeks! But these are clearly acquired by culture and place of residence, not blood. There are great differences among so-called races in different parts of countries. For example, there is more difference between Prussians and Bavarians within Germany than between the Bavarians and their German Swiss neighbors living in the mountains near the border of the two countries. Scotch, Irish, and English, of the same general stock and living within a few hundred miles of each other, differ greatly. So do the Bostonian and the New Yorker.

(G) FAILURES TO IMITATE PERSONALITY TRAITS OR ATTITUDES. It should be pointed out in all fairness that not everyone succumbs to such pressures and develops his personality by force of example. If this were true we would never have changes in the social structure. Sometimes we acquire attitudes just the opposite of those held by our parents. Professor E. A. Ross in his autobiography mentions that because of severe religious pressure early in his life, which not only compelled church attendance but forbade all pleasures on Sunday, he has felt depressed ever since if forced to stay indoors on a pleasant Sunday afternoon. He feels especially elated if he meets people on their way to church now that he is no longer forced to go. No doubt many people lost their enthusiasm for churchgoing by compulsion in their adolescent years. Some people who are strictest in following moral codes have had a parent or close relative who was a drunkard or had been a failure for a similar reason. It has been suggested that human society as a whole alternates in strictness of adherence to moral codes from one generation to another. This theory has not been proved; moral standards vary, but there is no reason to believe that the cycle is one generation in duration. In summation, we can say that departure from social custom is

exceptional; we conform to custom many more times than we depart from it.

7. Can One Change His Personality?^a

Since personality is almost entirely acquired, extremely malleable, and capable of being formed into almost any desired pattern, the next question is whether a person can deliberately change his personality after it has been formed. This is an exceedingly practical question, since many of us have traits which are undesirable socially.

It is generally assumed that personality can be altered. Parents, teachers, employers, and friends give advice; and books of etiquette suggest desirable modes of conduct. A number of recent books tell readers how to get along better with other people. (See Chapter VIII.)

Personality traits *do* change, if the desire to alter them is strong. Benjamin Franklin is said to have suddenly realized in his youth that he was not getting along with people because he was too positive in his statements. He resolved not to speak sharply, and he later became a noted diplomat. Most of us have made minor revisions in habits when they have resulted in embarrassment.

New experiences and situations disclose new traits. A person who has not shown leadership may develop remarkably if placed in a position of responsibility. Most people feel stage fright the first few times they speak in public; yet experience causes this nervousness to vanish. Illness or misfortune on the part of a relative or neighbor sometimes discloses hidden virtues of sympathy, self-sacrifice, and charity. War service, divorce, bankruptcy, or imprisonment may change a person's dominant mood radically and suddenly.

Certain personality traits may be shifted from moment to moment. A salesman approaches and talks to a customer in a vein which seems most suitable: he is jovial to a young person, precise and impersonal to a formidable older person, and retiring and modest in dealing with a pompous man. People behave differently when they are being interviewed for a position than when they are with associates of their own age and station. In fact, this is the reason why employment interviews so often fail to disclose the true personality; the applicant is usually acting a part and thus he conceals his real personality.

Can personality be changed over a broad front, or just in comparatively small traits? Will such changes be temporary or permanent? It seems doubtful that mature persons, of college age or older, can shift

^aSince this section brings together our arguments, it forms the conclusions for this chapter.

in anything as broad as introversion-extraversion, but specific habits can be changed.

Changes are probably achieved only through constant practice. Habits are likely to return when off guard or excited. Hence a person must watch carefully for months to overcome a habit such as that of snapping back with biting repartee when someone ventures a slight criticism. A shrill voice is a definite social defect and it usually takes months of constant watchfulness before the voice can be modulated on all occasions. It may also take much effort and time to build up an emotional habit: to overcome shyness with strangers and to greet them without hesitation. Such changes can be made and are worth the effort, but the task will take time and constant attention.

The older a person is the more difficult it is to change traits—not only because he is less plastic but also because he has practiced the old habit so many times. It is considered exceptionally difficult to change habits after the age of thirty, so that it is easier for a college student to correct undesirable traits than it is for an older person. It is still more feasible for adolescents to change. High school teachers criticize parents and grade school teachers who pass on children without correcting their faults. Finally, grade school teachers blame kindergarten teachers and parents! Personality development should be started in the early years and molded along desirable lines as the individual grows.

REFERENCES

1. Allport, G. W. *Personality*. New York: Henry Holt & Co., 1937.
2. Carlson, J. S., Cook, S. W., & Stromberg, E. L. Sex differences in conversation. *J. appl. Psychol.*, 1936, **20**, 727-735.
3. Garvey, C. R. Comparative body build of manic-depressive and schizophrenic patients. *Psychol. Bull.*, 1933, **30**, 567.
4. Husband, R. W. Body build and personality traits in college students. *J. gen. Psychol.*, 1938, **18**, 199-201.
5. Hoskins, R. G. *The tides of life*. New York: W. W. Norton & Co., Inc., 1933.
6. Howell, W. H. *Text-book of physiology*. (11th ed.) Philadelphia: W. B. Saunders Co., 1930. Pp. 896 ff.
7. Kretschmer, E. *Physique and character*. New York: Harcourt, Brace & Co., 1925.
8. Maslow, A. H. Personality and patterns of culture. Chap. XXII in "Psychology of personality" by R. Stagner. New York: McGraw-Hill Book Co., Inc., 1937.
9. Mead, M. *Sex and temperament in three primitive societies*. New York: William Morrow & Co., 1935.

10. Paterson, D. G. *Physique and intellect*. New York: D. Appleton-Century Co., 1930.
11. Paterson, D. G., & Ludgate, K. E. Blond and brunette traits. *J. Person. Res.*, 1922, 1, 122-127.
12. Stagner, R., & Katzoff, E. T. Personality as related to birth order and family size. *J. appl. Psychol.*, 1936, 20, 340-346.
13. Terman, L. M., & Miles, C. C. *Sex and personality*. New York: McGraw-Hill Book Co., Inc., 1936.
14. Wylie, I. A. R. Here and now; a word to parents. *Read. Dig.*, February, 1937.
15. Young, K. *Social psychology*. New York: Alfred A. Knopf, Inc., 1930.

GENERAL REFERENCES

- Richmond, W. V. *Personality, its development and hygiene*. New York: Farrar & Rinehart, Inc., 1937.
- Stagner, R. *Psychology of personality*. New York: McGraw-Hill Book Co., Inc., 1937.
- Watson, J. B. *Behaviorism*. New York: W. W. Norton & Co., Inc., 1930. Especially Chapter XII.

XIII

DEVIATIONS OF THE PERSONALITY

I. PERSONALITY MECHANISMS

Peculiarities, eccentricities, irregularities, and maladjustments of the personality should not be considered abnormal, unless we are willing to admit that each of us is, to some extent and at specified times, abnormal. Abnormality may be defined simply as a wide departure from the norm. A person who is completely honest or always generous is as abnormal as the dishonest or greedy individual. The genius is as *abnormal* as the feebleminded person, since both depart from the average level of society.

Anthropologists have contributed valuable data toward our understanding of personality. We have already noted their discovery that the men of New Guinea are submissive, the women quite aggressive. One tribe of American Indians is known as braggarts; in another modesty is so ingrained through early education that the children refused to work to capacity on an intelligence test because they did not wish to do better than their fellows. In these two tribes a modest and a conceited man, respectively, would be abnormal, but if they interchanged tribes, each would probably escape attention.

1. Conflict and Escape

Conflicts underlie most difficulties of personality. They are of all types: between sense of duty to family and desire to marry, between a wish for recreation and an obligation to work, between spiritual and material values, between fear and a steadfast desire to face a dangerous situation. These and many other conflicts are struggles between the inner mental life of the individual and the outside environment. The

environment often is antagonistic to the expression of a person's desire. In each situation, the conflict must be resolved either by victory for one or the other or, more often, by a compromise.

No one avoids these conflicts, no matter how rich, powerful, or talented he may be. Whatever the difficulty—love, family, business, illness, death—we face it and solve the problem in a normal way, an abnormal way (insanity), or a slightly irregular way. We shall discuss the last-named type of solution in this chapter.

The symptoms of abnormality are commonplace and omnipresent. One woman may become mentally unbalanced when she is disappointed in love, another because of the death of a relative. Men may go insane when they fail in business, and sometimes we hear of a student who commits suicide upon failing a course. All these incidents are unfortunate and they may cause severe mental anguish, but the normal person recovers from disappointments and grief. All of us experience situations just as unfortunate; if the incident alone were responsible, no one would escape insanity. The majority succeed in adjusting themselves; the minority break down to a lesser or greater degree. Here is one case of failure to adjust.

Mrs. P. suffered because of the death of her older sister, aged 73, from cancer. Eighteen months later she was still going to mass every morning to pray for her sister. She deliberately prolonged her grief and, if an acquaintance met her on the street, she would draw a long face and answer polite inquiries by announcing that she was "heartbroken." She vehemently denounced all doctors and medicine, because her sister wasn't saved, in spite of her sister's age and the fact that a doctor had not been called until five days before her death.

Before we label such people as needlessly maladjusted we must discover how important the cause is to the individual involved. The tip of one finger may be a more serious loss to a concert pianist than a whole arm to another man. To some people an aunt may be closer than a mother. These exceptions do not alter the general argument, however.

Is *radicalism* an evidence of inability to adjust to one's environment? Several writers suggest that desire for orderly progress is a normal trait but that militant efforts to remake the social order are abnormal and, perhaps, an evidence of immaturity. In the latter case, the individual does not adapt himself to society as he finds it, but attempts to reshape the world according to his ideas. Since most people are conservatives, believers in things as they are, the radical often has a bad time of it. It would be convenient if we could label them all "abnormal" and let it go at that. Some people actually believe they

have described a thing when they have given it a name. From the point of view of "standpat" ideology, Jesus Christ, Martin Luther, and Abraham Lincoln were radicals. They were dissatisfied with certain aspects of the social order of their times, and they set in motion powerful forces for the improvement of mankind. Therefore, it is necessary to differentiate the true radical from the chronic complainer who has a grudge against society because he has fared poorly.

Escape. If the individual finds himself unable to adjust himself to reality, he may seek a way to avoid facing the issue squarely. *Sympathy-seeking* is a common mechanism. The person calls attention to the enormity of his plight, dramatizing himself as a victim of extraordinary bad luck. He thus avoids an admission of responsibility and rescues his pride.

P.P. has never felt that she should have anything of her own. At the table she served her husband and the children generously, leaving almost nothing for herself. In fact, she specialized upon leftovers and secretly picked the bones that remained on the plates of the family. Her room was the least attractive in the house and she slept upon the poorest bed. She dressed shabbily and although she was a very heavy woman she always bought shoes that were tight and binding. Her feet hurt so that when she went to bed at night she had to rub them for half an hour, and she was wont to say that this was her only pleasure in life. No one could persuade her to wear a larger shoe, she enjoyed her self-pity so heartily. In every way P.P. has made herself the victim of her children and seems to take pride in their evidences of callous selfishness. Her husband is brutal and bullies her, but she would not leave him for worlds and appears to enjoy dwelling upon his ill treatment. Her face becomes fairly radiant when she speaks of his unkindness and cruelty. [10]¹

In this case a person who is probably not distinguished in any respect commands attention by appearing to be the victim of many woes. Most of us know people who actually enjoy martyrdom.

Taking drugs is another means of escaping from reality. Alcohol and morphine are common examples. The addict usually has a worry or a conflict which he tries to avoid by putting himself into another mental state. To a lesser degree, steady moviegoing or participation in parties night after night suggests that the individual is bored with himself, is unwilling or unable to interest himself in more substantial aspects of life.

Regression to more primitive or infantile modes of behavior is still another inadequate mode of conflict solution. When the bureau drawer sticks, a person jerks it hard and curses. In more grossly maladjusted

¹Jones, E. *Psychoanalysis*. New York: Cape and Smith, 1929.

cases, people actually revert to an earlier stage of development, not only emotionally but intellectually.

The author once had as a patient a young woman whose parents were killed in an automobile accident when she was sixteen years of age. It was necessary for her to go to work, and she had considerable difficulty in eking out a living. When she was twenty-four she fell madly in love, but in about a year her lover married another woman. A few months after his marriage, the patient began to act queer, to play with dolls, read fairy stories, and do other things characteristic of a girl of eight or nine years. On investigation it was found that she believed she was once more happy in her old home surroundings. By ignoring the unpleasant realities of the present and reverting to a happier state, she had escaped the annoying conflicts which tormented her. [20]²

Similar symptoms appear in some college students, but they denote emotional immaturity rather than definite abnormality or regression. If one goes home every single week end, writes lengthy epistles to parents every day, and consults them before making minor decisions, he is emotionally well below the age of eighteen. Students who continue to take college work after graduation, with no professional ambitions, may be suspected of fearing to face the world of work and of wishing to remain in a sheltered environment. Men have joined the army or the navy to escape a vocational decision or an unpleasant home situation.

Suicide is the most drastic form of escape. A situation may seem so intolerable that the sufferer can find no other way out.

2. Functional Disorders and Repression

The mental and physical are closely interrelated. A sick person's rate of recovery is influenced decidedly by his attitude. Many disorders are purely psychological in character, without a trace of physical lesion. This was demonstrated clearly during the World War. Soldiers developed mysterious cases of paralysis, blindness, and anesthesia. Since no wounds were present, at first these disorders were attributed to shell shock. But it soon became apparent that many cases occurred behind the lines, and even in training camps on this side of the ocean. When the soldiers were placed in hospitals far behind the lines, rapid recoveries took place. Yet when they returned to the front, or were in danger of being sent to the front, the symptoms developed anew. It was evident that the cause was fear. The soldier was, naturally enough, afraid for his life, but social pressures kept him from the direct solution of running away; so a compromise solution was unconsciously effected. If he became paralyzed or blind he was obviously

²Moss, F. A. *Applications of psychology*. Boston: Houghton Mifflin Co., 1929, p. 204.

unfit for service, yet at the same time his conscience was clear. Let us emphasize that malingering was out of the question; no one could fake such disorders and pass tests given by competent psychiatrists.

Similar cases occur in civil life. A widowed mother whose only son was about to get married became paralyzed. She urged her son to go ahead with the wedding, but she was clearly dependent upon the couple for her care. This mechanism served several ends: she kept her son, added another person to care for her, yet saved her face by not displaying her true desires in a socially disapproved manner. The following excerpt from a story illustrates this sort of mechanism perfectly. [6]

Finally one night he screwed up his nerve and spoke right out at the table: "Miss Florabelle, I got to drive to town to send a money order this evening and Jig has loaned me his car. Would you care to come for the drive?"

"Oh, I'd love to if—— Do you mind very much, mother? It will only take us an hour, and I haven't been out of the house all day."

I looked for the old lady to scream, but all she done was smile.

"Why no dear; it will make a nice little outing for you."

But as the two started out the door half an hour later, the old lady called after her, "Oh, Florabelle, would you mind very much just getting me the aspirin first?"

Florabelle got it, and then the old lady smiled again, sweet and brave.

"Now go and have a nice time, dear. This headache may be gone by the time you get back. I may not even need an ice pack, and even if I should——"

"I'd get it for you," says Beckett.

"That's very thoughtful of you, Mr. Beckett . . . Now you run along, Florabelle. Often these terrible headaches have no connection at all with my heart."

"They couldn't," says Beckett, "or they wouldn't need no ice."

But Florabelle had taken off her gloves and hat.

"I'm sorry, Sheldon," she says, and then set her face into that nice, kind look it always wore for her mother.

"You'd better let me take you upstairs, mother. You'll be more comfortable there."

"Oh, I do hate to delay you, but perhaps if you would get me settled and read to me for just a little while, till the worst of this has passed——"

As we went up to our rooms about midnight, we could hear her in there, still reading to the old lady. . . .³

Plaintiffs sometimes come to court in a wheel chair or on crutches, but after they have obtained a favorable verdict they walk without

³Haines, W. W. High tension. Boston: Little, Brown & Co., 1938.

assistance. As long as there is an incentive in being incapacitated, the condition will persist. Supposed miraculous cures at shrines are often due simply to confidence. Limbs may have strengthened previously or eyes may have improved, but the patient had not ventured to get along without assistance of braces or glasses.

In such instances, invalidism is an indirect and unsatisfactory solution of the conflict. By developing the disorder the person obviates the necessity of a direct solution by accepting other limitations. We repeat that the mechanism is unconscious; the patient not only has not deliberately planned the functional disorder, but he is also totally ignorant of its workings. Such a solution is only partially adequate, since it may act only temporarily or it may impose a handicap almost as distressing as the situation avoided. The mother in the story cited above had to accept an invalid's limitations in order to keep her daughter from marriage.

In lesser measure we find daily examples of the escape mechanism. A headache that prevents a person from studying or working will vanish if he is invited to a party. Many students feel too ill to take mid-semester examinations, but few remain in the infirmary during a vacation or prom week end. One high school boy missed school six consecutive Mondays, supposedly because of illness; analysis disclosed that he disliked the mechanical drawing class held that day.

3. Prejudices

Our prejudices demonstrate the existence of unconscious memories; that is, events which are not recalled clearly, but which, nevertheless, influence our behavior or our attitudes. Many prejudices originate in minor incidents of childhood.

"When the word 'foreigner' is mentioned," a young lady admitted, "I think of Limburger cheese. In grade school an immigrant girl of respectable family sat opposite me. During school hours she continually ate Limburger cheese, keeping a great smelly piece in her desk. I mentioned it to some friends. They laughed and said, 'Oh well, she's a foreigner.'"

A distasteful attitude toward foreigners was thus initiated because of a single bit of behavior on the part of one girl of one nationality. Our opinions concerning members of a racial or religious group may often be traced to an acquaintance with groups in our home town, or even to a single incident in which one of the groups was concerned. Such prejudices may be favorable as well as unfavorable.

⁴Duffus, R. L. Where do we get our prejudices? *Read. Dig.* 1937, 16, p. 7.

Employment interviewers must train themselves against allowing their judgments to be warped for or against persons on bases other than true merit. Scientifically trained personnel workers have progressed a long way from the Irish foreman who bragged that he hired only red-haired Irishmen. The foreman at least admitted his prejudices; many of us claim to be free of them, but our actual behavior shows that we are not.

4. Logic-tight Compartments

Conflicts are sometimes avoided by not allowing two contradictory sets of ideas to come in contact with each other. The college freshman may do creditable work in a course in geology or biology in which he learns about the gradual evolution, over millions of years, of the earth and the animals living upon it, and yet on Sunday he may be able to accept the Biblical story of creation of the earth in six days. One nation justifies its foreign conquests by citing the pressure of overpopulation at home; at the same time it awards prizes to families with the greatest number of children. All of us show minor inconsistencies which can be classed as logic-tight compartments, such as counting calories at meals but eating candy and milk shakes throughout the day, or advocating the fairness of the income tax but seeking loopholes to reduce our own.

More striking schisms appear in definite insanities. In institutions one finds patients who insist upon being called "Your Majesty" while they are on their hands and knees scrubbing the ward floor. The incongruity does not occur to them, since their pretensions to royalty and the meniality of their labor are kept strictly apart.

This mechanism reaches its extremity in the dual personality. This phenomenon was made popular in *Dr. Jekyll and Mr. Hyde*. Here the conflict involves systems of such breadth that they cannot be kept apart. For example, a high-minded banker in a small city, whose bank became insolvent during the depression, worried so much about the distress it created that he lost his memory and disappeared. He was found months later doing crude manual labor in a city a thousand miles away. He had no memory of his name, former residence or occupation, and failed to recognize even members of his own family. Treatment by a psychiatrist relieved the amnesia and brought him back to normal. The mental mechanism had worked as follows: The conflict dealt with a topic so much the center of the banker's life that a complete loss of memory was the only alternative to violent insanity. A number of cases of minor amnesias lasting for a few days occur each year. A brief rest usually relieves these disorders.

5. Freudian Slips and Errors

The famous psychoanalyst, Sigmund Freud, insisted that chance plays no part in mental processes. Behind everything there is definite cause and effect, known or yet to be discovered. He applied this reasoning to errors, slips of the tongue and of the pen, misreadings, and misunderstandings. The man who forgets his wife's birthday, Freud says, is showing that he no longer loves her as much as formerly, regardless of his claims and protestations. On the other side, Freud claims that when a woman loses her wedding ring while on the honeymoon the marriage invariably breaks up soon. Losing the ring discloses the waning of affection even before the woman realizes it. If a person misplaces or fails to mail a letter, he does not do so by chance but because he finds the contents unpleasant. Such things may be recalled at "safe" times: a businessman remembers after office hours that a certain letter should be written; a student remembers that he should have drawn out a book after the library has closed.

Many slips sound trivial, but to a mental detective they contain great significance. Such acts give evidence of true wishes, which are buried in the unconscious. A person cannot remember the married name of a woman; this is proof that he disapproved of her marriage. Dr. Ernest Jones, one of the leading English-speaking psychoanalysts, says that when a patient calls him "Dr. Smith" he is under no illusion about that person's private opinion of his professional competence.

Conversational slips are also said to reveal true thoughts. A newspaper reported: "Among those present was His Highness, the Clown Prince." The next day the paper apologized, and called him the "Crow Prince." Two consecutive slips leave no doubt. Similarly a war correspondent called a general in two dispatches, "this battle-scared veteran" and "the bottle-scarred veteran." A woman complimented a friend on her new hat with, "I am sure you must have thrown—Oh, I mean 'sewn'—this hat together."

Evaluation of these arguments meets the same criticism which may be applied to many psychoanalytic concepts—exaggeration of the frequency of the mechanisms. No doubt people do forget duties or appointments of doubtful pleurability, and occasionally they do blurt out the embarrassing truth. But to attribute all forgetting and every blunder to expression of the unconscious is a different matter. We may also forget to mail a pleasant letter or to keep a desired date, and we may become confused over a friend's name and be very much embarrassed about it. The theory contains some truth, but it should receive limited and cautious acceptance.

6. The Inferiority Complex

(A) NATURE. Inferiority complex is another psychological term heard frequently in daily conversation and with a good deal of accuracy. A feeling of inferiority arises because of real or imagined failure to come up to what one expects of himself.

Demonstration of the existence of this mechanism may be (1) direct, where the person actually behaves as if he were inferior by keeping in the background, refusing to try to do things, and deprecating himself; and (2) indirect, where he compensates for an inferiority feeling by taking the utmost advantage of authority, making himself the center of attention, bragging about minor accomplishments, lying about failures, and taking criticism ungraciously.

(B) CAUSES. As with many other psychological processes, egoistical factors are important. No one likes to suffer in comparison with others. Everyone likes to feel important in some way or to somebody. The origin of inferiority feelings therefore lies in comparing oneself with other people. If a student makes grades below the average of his class or his particular friends, if he does not make the football team, if he is not popular, or even if he is ashamed of his family background, he may acquire an inferiority complex. Clearly, then, it is largely a matter of comparison. A boy may have been a leader in a small high school, but he escapes notice in the university. Under more severe competition he does not fare so well. To be a "big frog in a small puddle" may give better emotional balance and more happiness than to be a small frog in a big puddle.

Many inferiority feelings are entirely unjustified. A bright boy may feel inferior because his older brother is slightly brighter; a dull boy may be self-satisfied if his brother is definitely feeble-minded. One genuine case of inferiority concerned a boy whose father was a distinguished scientist and whose brother was a Rhodes scholar. The boy had graduated from college with a high, but not brilliant, average. He was better than 90 per cent of college graduates; yet he felt inferior because two other members of his family had been better than 99 per cent.

Regardless of actual accomplishments, inferiorities may develop because of a failure in some desired direction. A football player may regret not having made higher grades; an honor student may feel that his college career has been wasted because he did not earn an athletic letter. Menninger quotes an instructive case: [18]

Evelyn Hawkins made Phi Beta Kappa. Three months before she was to be graduated, she left school. This is what she told her room-mate:

"I went to school nearly four years. I was supposed to be one of the most popular girls in school. I made good grades, as you know; I was at the head of committees; I was president of my sorority. But during all that time I had just exactly three dates with men. One of them I invited myself to one of our own parties, and one of them was got for me by a common friend. What is there about me that makes me so uninteresting to men? I went and asked some of my friends. They told me I was too intellectual; they told me I didn't flirt enough, or put myself out. They told me I was a prude and didn't do enough necking.

"So I did my best to change all these things, but without the slightest results that I could see. If I'm not capable of interesting men, I'm not capable of being a wife; and if I can't be a wife and mother, I don't care to live at all. What's all this intellectual development worth? I'm not going to spend my life teaching other folk's kids; I want my own."⁶

Adler, another renowned psychoanalyst, felt that all inferiorities originate in organic weaknesses. [1] While there is no denying that some do, it seems more likely that the majority have social or psychological causes. Physical characteristics which may produce such feelings are: being undersized; being homely, especially in girls; being lame, humpbacked, cross-eyed, or otherwise not perfectly formed; having scars or bad complexion; being weak or having heart trouble and thus being unable to participate in the activities of the group. All these cause the individual to compare himself unfavorably with others.

(C) COMPENSATION. Sometimes inferiority feelings react indirectly upon the individual. He feels inferior but acts superior. In some cases this *compensation is direct*. A weakling builds himself up. A poor writer learns to use correct rhetoric. A shy person learns to mix with people. But this process does not usually stop with bare success. The motivation resulting from a sense of previous defeat is too powerful. He *overcompensates*. A person who has an inferiority complex because he came from an uncultured environment may not be satisfied when he receives an education and acquires socially approved manners. He may cultivate an affected accent, sneer at displays of crudity in others, pretend to enjoy symphony and opera, and become generally snobbish. Undersized men who have doubts concerning their masculinity compensate by having frequent dates, smoking huge pipes, swearing violently, and bragging about their exploits. A college girl who had few dates was invited to a fraternity dance at a country club in another town. She jumped at the chance to go, but wrote to a friend, "What a nuisance. Those idiots are holding the party forty miles away." A splendid instance was furnished by a political appointee who had been

⁶Menninger, K. A. *The human mind*. New York: Garden City Publ. Co., 1930, p. 6.

under fire for favoring certain groups. He thereupon employed a Catholic, a Jew, and a Negro in his office, and called in reporters to announce the fact as evidence that he was unprejudiced.

There may also be *indirect compensation*. In this case the person does not attempt to compete in the field of his weakness, but compensates by striving for superiority in other directions. A boy who stammered so badly that he could not recite in class took as many writing courses as possible, and became one of the editors of the university newspaper. Socially unattractive people may study hard and make much higher grades than their general ability would predict. People who are too small or too awkward to excel in sports become active in music, debating, or dramatic work. This form of compensation is perfectly healthy, since the individual keeps his sense of proportion and often achieves success in another field. On the other hand, no one should avoid everything in which he does not find himself immediately proficient; morale is raised if a person succeeds despite handicaps.

(D) **PATHOLOGICAL LYING.** Pathological lying is a sign of inferiority feelings. Most of us have a friend who tells prodigious stories in which he is always the hero or central figure. His stories involve miraculous feats he has performed, narrow escapes he has had, large sums of money he has earned, splendid positions he has held, famous people he has known intimately, and political power he can wield. Major Hoople in the cartoons is a splendid example. Usually such a person is actually leading a humdrum life, without means or influential friends, but his exaggerated claims enable him to bolster his self-respect.

(E) **IS THERE A SUPERIORITY COMPLEX?** This is a moot question. Adler and his followers claim that there is no such thing, for reasons similar to those advanced above (see Section [C]). If one is modest, they say, he has a feeling of inferiority; if he is not modest, then he is compensating for an inferiority. It has been pointed out that they have you coming and going; no matter what your behavior, it is evidence of inferiority. If a person brags about something in which he is truly skillful, as do a few athletes, the Adlerians might say that he acquired his skill in order to compensate for some previous feeling of inferiority.

(F) **OVERCOMING THE INFERIORITY COMPLEX.** Many persons are seriously handicapped because they have excessive and unreasonable feelings of inferiority. In some cases the condition may be corrected as in the following instance: [19]

A stenographer, aged 24, had been under treatment for two years for a very bad disfigurement of the face caused by dental deformities. The mental effects were particularly marked. She had always taken a position in the

back office where it would not be necessary for her to meet the public. Two years later, after the deformity had been corrected, she was working in the front offices and wearing an engagement ring.⁶

Obviously the physical defect had preyed upon her mind to such an extent that her behavior actually exaggerated the trouble. The formation of a sane attitude is important in such cases, especially if the condition cannot be corrected.

Finding an activity in which one can excel is the best way to get rid of an inferiority feeling. A bashful boy overcame his social fears a short time after he had been praised for a musical performance in the school assembly. A boy who failed to make the football team recovered his pride by making his letter in a minor sport. A girl who was really "homely as a mud fence" became one of the most popular girls in school by developing her personality, never saying an unkind word, and always giving the boy with whom she was spending the evening the impression that she had never enjoyed herself more in her life.

Severe comparisons between persons should be avoided. A person should not be placed in a situation so far beyond his capacity that he is sure to fail. If he is of mediocre intelligence, he should not be compared with college students but with skilled laborers and clerical workers. He will be far happier as a successful clerk than as a bad accountant. In the proper setting, he can watch his own improvement with pride and he will not be doomed to remain at the bottom of his group.

Doris was an attractive girl, but not very bright. Her two older brothers had become doctors, so the family expected as much from her. She really should not have attempted college. Failing several subjects and being placed on probation, plus family censure, made her hysterical, until finally she broke down and went to the infirmary. She tried to steal poison and commit suicide there. It was explained to her later in a very tactful manner that her inclinations were not along scholastic lines, but that there were many other very desirable lines of endeavor. She withdrew from the university, took secretarial training, and is now happy and cheerful as ever.

7. Rationalization

Rationalization is a defense mechanism by which one's pride is saved or his conscience soothed. Because we hate to admit that we are wrong, we invent an explanation that "saves our face" instead of giving the real reason for our performance. Suppose you arrange to call for a friend at two o'clock to play golf. You arrive and find that he is not dressed and has not located his clubs. Instead of admitting frankly that

⁶Menninger, *op. cit.*, p. 71.

he has been careless, he tries to save his pride by making excuses about telephone calls or other interruptions.

Rationalization is perhaps the most common personality mechanism. We almost always invent an alibi to justify behavior which we admit to ourselves is logically unjustifiable. The student goes to the movies when he should be studying, but he rationalizes that he needs relaxation. The drinker says he needs to pep himself up or that he needs to forget his cares. The large owner of stocks and bonds argues that a high income tax is bad for business; the property owner has reasons why taxes should be on income instead of property. Here is an amusing instance. A minister from the Far West was visiting relatives in the East, and one Saturday night the group was playing dominoes. The others expected him to stop sharply at midnight, since he was violently opposed to games on Sunday. His daughter finally remarked that it was midnight; whereupon the minister looked at the clock and replied, "Oh, well, it's only ten o'clock Pacific time."

Groups as well as individuals display rationalization. This fact can be observed clearly in international affairs. In the World War each nation gave a socially approved reason for its participation. Some claimed self-defense, others said they were defending smaller nations from aggression, still others that the world must be made "safe for democracy." Likewise, certain races and nationalities are persecuted because the ruling group needs a scapegoat upon whom they can blame all the country's ills.

8. Sour-Grapes Attitudes

This mechanism takes its name from the legend of the fox who jumped for a bunch of grapes hanging high in the air; after failing in repeated attempts he departed, saying that they were sour anyway. In other words, admission of failure is avoided by pretending indifference and by insisting that the goal is not worth striving for.

Frequent examples are encountered in college life. Low grades elicit the remark that "Phi Betes are all dull grinds." One who is not elected to a club says, "It's just as well. It costs a lot of money and takes up too much time." If one fails to make the football team he may say, "I might have got my finger or nose broken, and besides it's too much work for what you get out of it." A politician who is not elected declares that he is glad not to have to associate with crooked officeholders. Behavior itself may denote a sour-grapes attitude. If a person drops a book in a mud puddle, he may pick it up with a casual air and walk off whistling. When a person loses an election or an athletic contest, his nonchalance may be a way of concealing his true feelings.

Negative sour grapes, sometimes called a sweet-lemon or a Pollyanna attitude (from a character in fiction who was always being "glad" about everything), is a means of compensating for hurt pride. Since the person does not like to admit disappointment, he salvages whatever comfort he can from minor elements in the situation. "Every cloud has a silver lining" is an epigram founded upon this mechanism.

A person who cannot afford a car often points out the health advantages of walking. Another has a small wardrobe because it is easier to choose what to wear. A person who has suffered misfortunes says that they develop character. Hard times are with us now, but think how happy we shall be in the more prosperous future. We lost the game, but we did well to come that close to the champions. The attempt to turn embarrassment into a joke is a more complex, but similar, procedure. Occasionally a person tells a story on himself, as if it were a huge joke, in order to forestall a less favorable account by someone else.

Like the other mechanisms we have been discussing, *sour grapes* has the function of protecting and bolstering the ego. It may produce more harm than good if an individual begins to use it as a refuge from his deficiencies.

9. Projection

Projection is another common mechanism for shifting blame to others. A person ascribes to others thoughts or deeds of which he is guilty himself, possibly in the unconscious. I chide my friend for being a loafer, and he recounts the number of times in the past week I have gone to the movies, have played cards, or have otherwise spent time unprofitably. I tell him he should dress better, and he thinks of instances where I have been far from a fashion plate. A politician who cannot defend himself against a charge of corruption names instances of crookedness on the part of the opposing party. In this way a person does not deny his guilt, but attempts to pull a rival down to his level. Since comparisons are always relative, such a device may be useful in maintaining self-respect.

In some cases projection actually occurs in advance of an accusation. The famous play within a play in *Hamlet* contains such an example. The Queen, hearing the player-queen's extravagant declarations of love, remarks, "The lady doth protest too much, methinks." The supposition is that, if there were a clear conscience, a simple statement would suffice. People who continually discourse upon the subject of morality in others may be suspected of having a guilty conscience themselves, or possibly of overcompensating for an immoral past.

The existence of this mechanism was verified in an experimental study by Sears. [22] He asked each member of three fraternities to rate his fraternity brothers and also himself as to degree of possession of several slightly undesirable traits. Those chosen were stinginess, obstinacy, disorderliness, and bashfulness. Particular attention was paid to the ratings of those whom their friends considered poor in a particular trait, but who showed by their rating of themselves that they failed to have insight as to their own shortcoming. It was found that these individuals tended to attribute that unrecognized fault to others. A student who was considered stingy by his friends, but who failed to realize it himself, would give his friends poor (undesirable) ratings on that trait. But those who understood their own shortcomings gave their friends favorable ratings. A student who was inclined to be stingy, but recognized the trait in himself, rated his friends as more generous than average. Since conscious realization of a fault tends to eliminate projection, we have evidence that this mechanism is generally unconscious.

In certain kinds of insanity, projection, sometimes accompanied by overcompensation, is seen in clear-cut forms. A "washing mania" is a not uncommon form. The patient washes his hands literally dozens of times daily, and psychiatrists take this as evidence that the patient thinks of himself as soiled, not physically but mentally, and that he thinks everyone and everything with which he comes in contact is equally dirty. Similarly, women who feel tempted toward sexual irregularities often accuse men of following them about and of making improper advances.

On this subject, Hart says: [8]

In general it may be said that whenever one encounters an intense prejudice one may with some probability suspect that the individual himself exhibits the fault in question or some closely similar fault.⁷

10. Sublimation

Sublimation is defined as the diversion of one kind of energy into a new channel. Generally it is from a primitive or socially disapproved mode of conduct into a more acceptable pattern of behavior. It has been claimed that the creative energy essential to a complex civilization is sublimated from the more physiological energies used by primitive man for fighting and sex.

At times sublimation may consist in toning down behavior within the same field. In many instances it results in highly desirable social

⁷Hart, B. *Psychology of insanity*. New York: The Macmillan Co., 1931, p. 131.

conduct. Women who have not married may dedicate their lives and unsatisfied maternal urges to nursing, teaching, or helping unfortunate children. A bachelor or wealthy man without children may send poor boys and girls to college.

Certainly sublimation is at best imperfect. The thin veneer of Western civilization has not yet been able to repress wars, attacks of violence, rape, or immorality.

11. Wish Fulfillment, Fantasies, and Delusions

We have already suggested that certain mechanisms work in the imagination rather than in actual behavior. Because some desires cannot be fulfilled in actuality, they are achieved in the imagination. The teacher or minister commits himself to a life of modest income and knows that expensive travel and country estates are out of the question. The lame boy knows that he cannot expect to become a champion runner. But a person may brood about his disability, lapse into fantasy thinking, and finally imagine that he has attained his goal.

Fantasies are the images created in reaching imaginary goals. They are perfectly normal unless they interfere with normal social and business balance. We all build air castles now and then, but we should not let them dominate our thinking.

Delusions follow the same line as fantasies, but they are distinguished by being persistent and in some cases are systematized. By the latter term we mean that they center about a whole topic, say personal power or financial success, rather than about several miscellaneous topics. They take three forms: delusions of reference, delusions of persecution, and delusions of grandeur. In *delusions of reference* a person imagines that he is the center of all attention or activity. The following story illustrates this delusion.

Helen was playing a girls' basketball game in high school. She fell down rather heavily, but got up immediately and resumed playing without pause. Although she scored most of the team's points and played a fine game, she worried for days over her apparent awkwardness, and thought that everyone had seen and remembered that one incident. Actually few did, as probably all the players fell down at least once during the game.

In *delusions of persecution* there are the same feelings of reference, plus the suspicion that people are insulting him or plotting against him. If two people are talking together in a low tone of voice, they either are making fun of him or planning to do him personal violence. Students often save their faces after failing a course by claiming that the instructor did not like them.

Finally, in *delusions of grandeur* unattained self-importance is realized through the imagination. A person says that he is King of the Universe or has fifty billion dollars hidden away. These are often coupled with persecutory delusions, since it is obvious that there is an inconsistency in the situation, and the deluded person feels that he has to explain the contradictions. He tells incredible stories about armies of ten million men mustered by his enemies to prevent him from ascending the throne or obtaining a treasure. Such a patient may be dangerous, since he may suspect relatives, friends, and doctors of plotting against him.

SUMMARY

First, *facts*. Virtually all the points in this section have shown that our personalities are replete with mechanisms designed to maintain self-esteem. If direct adjustment is not effected, an irrational substitute mechanism produces an indirect, but pragmatic, solution. Although illogical, the individual fails to recognize it as such. If he did, the true state of affairs would be obvious to him and his pride would be severely wounded. So we have our compensations, projections, rationalizations, logic-tight compartments, sour-grapes attitudes, and fantasies.

Second, *implications*. We do not wish to imply that these mechanisms are truly abnormal or wholly undesirable. Far from it. We all display each of them to a greater or a lesser degree. While most of them are a bit irregular or irrational, few of them, if reasonably restrained, create real social or professional handicaps. Few of us excel at everything, and all behavior need not be perfectly reasonable. Emotional balance and happiness may require the existence of various compensatory mechanisms. However, one should attempt to control his prejudices. He should admit his weaknesses, recognize his rationalizations, and restrain his projections. There are situations in which an honest facing of the facts is necessary, and there are also situations where compensation and fantasy thinking may be tolerated.

II. MENTAL HYGIENE

1. What It Is

Living in order to avoid dying presents very little that is either worth while or stimulating as an ideal. Mental hygiene presents a positive program for life well lived. [25]^a

^aWhite, W. A. The origin, growth and significance of the mental hygiene movement. *Science*, 1930, 72, 81.

(A) **DEFINITION.** Mental hygiene is concerned with personality maladjustments which interfere with the individual's efficiency and happiness. For instance, many college students fail, not through lack of ability but because of emotional problems. If these emotional conflicts can be prevented or cured, the student will do better work and be a happier person.

The scope of mental hygiene may be indicated by listing a few typical problems: jealousies and fears in young children, adolescent conflicts, juvenile delinquency, adult criminality, neurotic tendencies, abnormal love adjustments, divorce and marital maladjustments, inability to face new or trying situations.

We have learned that people who have emotional difficulties can be cured only by patient and sympathetic treatment, not by brutality or threats. In the Middle Ages insane people were cast into dungeons and chained like beasts. However, the rapid development of psychiatry, psychoanalysis, and mental hygiene during the past century has radically modified treatment of abnormalities. Since mental hygiene deals with the less spectacular cases, it developed later and has received less attention from the public.

(B) **PREVENTIVE PURPOSE OF PERSONAL MENTAL HYGIENE.**

All forms of social maladjustment and even of unhappiness were seen to have mechanisms quite the same as the more serious conditions with which we were more familiar. The mental diseases of the public institutions were obviously end products of many years of bad mental hygiene, and so the question at once arose as to the possibility of cutting off the source of mental disease at its origin by getting back to the beginnings and correcting the difficulties at that point. [26]⁹

Just as we can acquire desirable habits of eating, sleeping, and preventing physical disease, so we can teach ourselves correct emotional and intellectual habits. If a person is maladjusted, he should be treated when the first symptoms are detected, not after the trouble has become deep-seated. Let us quote an example to illustrate this.

Students and faculty of a large university were greatly shocked to hear that a prominent senior had committed suicide. He was a brilliant student before his maladjustment set in, and also had won his letter in two sports, being considered the most valuable member of the football team. He had always been rather quiet and introverted, and as early as his sophomore year it was evident to his close friends that he was brooding excessively. He was too introverted to make a good football captain, but nevertheless he was bitterly disappointed when his team mates did not elect him, and even

⁹*Ibid.*, p. 79.

left school for a short while. A member of the psychology department recognized the state of affairs and called it to the attention of two administrative officials, not only for the sake of this case, but also as an argument for the establishment of a mental hygiene service at the university. The only comment was: "Well, if he can't stand on his own feet at his age, let him go." Who knows but that these officials in effect signed the death warrant? He was such a fine and promising scholar that his football disappointment need not have meant as much to him as to someone who came to school solely for athletic purposes. It is only too evident that skilled outside help would have saved him.

In the United States approximately 150,000 persons are admitted annually to insane hospitals; in New York State it has been estimated that one person in twenty will sooner or later spend some time in a mental hospital. [9] An equal number are cared for privately. No doubt the majority of these cases could have been prevented if the symptoms had been recognized early enough.

It is said that 85 per cent of college students (probably a typical section of the entire population in this respect) could profit from adjustment guidance, and that 10 to 15 per cent are badly in need of it. The greater group is composed of people who would never become serious problems, but whose maladjustments prevent them from living balanced and efficient lives.

No one should hesitate to seek aid from an expert in this field. A person should not feel any more sensitive about seeking assistance concerning emotional problems than consulting a doctor about a cold or a professor about better study habits. The hygienist is an expert at adjusting emotional conflicts. Ministers also are often excellent counselors; their efforts to relieve emotions and their sympathetic attitudes often give reassurance. In fact, the man who is generally recognized as the leading psychoanalytic practitioner in the world is a Swiss pastor, Oskar Pfister.

2. Physical Causes

Extreme sensitivity and even neurotic symptoms are often caused by a physical handicap. To illustrate, we quote from the autobiography of a college girl. [27]

I was only a baby—only two and a half years old when the tragedy that colored my life and determined my personality happened. The fire that disfigured my hands and left scars on my body . . . My parents could not have been more wonderful . . . Not a word was said of my handicap at home and it was never looked upon as such. I was never petted or babied and led a normal healthy life . . . When I was eight, I wanted to take

piano lessons. In the face of open criticism from our relatives my Mother engaged a teacher.

Children are thoughtlessly cruel, . . . "What's the matter with your hands?" or "Gee, you have funny fingers." . . . Between the ages of 14 and 18 I was most sensitive. I wanted pockets put in all my clothes. . . .

Hands are such obvious parts of one's body. Wonderful as Mother was to me she couldn't live and think for me and she could not always put kind words into people's mouths instead of the crude, brutal words that brought tears to my eyes and tears that I gave way to in private only. . . .

Are people blind? Don't they realize how sensitive I am to the slightest glance at my hands, to any allusion to hands at all? I've learned to cook and sew, to swim and to drive a car, and I can do those things a little better than the average girl. If my parents had given ear to my relatives, I would have been a handicapped child today. . . .

Blind dates are anathema to me. All evening I am miserably conscious of my hands and keep them gloved as much as I can.¹⁰

This selection was chosen to show how intelligently this girl's family had treated her, but it also gives several constructive suggestions about meeting and treating people who have handicaps.

Healthy adjustments require thoughtful treatment on the part of family, teachers, and friends. A child should neither be coddled nor treated as an "ugly duckling." We should take for granted the child's normal participation in society, permit him to capitalize on his assets, and assist him to minimize his liabilities. Special school and home programs may be necessary, but they should appear to be normal and natural. The following case shows the healthy results of constructive treatment. A college girl who lost her right hand at the age of six said:

My family didn't treat me any differently from any of my brothers or sisters; I had to do the same chores. I played baseball with my brothers. The chief trouble was trying to catch a fast ball with one hand. . . . I have gotten used to it, so it doesn't bother me any more. . . . I can tie my shoelaces so they stay tied all day. . . . This summer I am going to cook and keep house for two of my brothers who are living away from home.

In contrast notice this unhealthy attitude from a man of thirty.

I lost my right foot just above the ankle. I can't find work. I think society should take care of people with such handicaps as mine.

Deaf people often become suspicious. As their hearing becomes less acute they tend to think people are whispering about them. When they

¹⁰Wright, V. C. *Personality analysis of college students by the methods of tests, inventories, and autobiographies*. Ph.D. Thesis. Madison: Univ. of Wisconsin, 1931, pp. 279 f.

become totally deaf, their delusions of persecution may heighten. Part of the adjustment is simply to understand this tendency, so that it may be combated by the sufferer himself.

3. Disorders of Infancy and Childhood¹¹

It is often presumed that a child's life is so simple that conflicts of a serious nature cannot arise. This is not the case; what adults are tempted to consider petty worries are just as real to the child as the adults' business troubles or emotional crises are to them. Further, minor maladjustments tend to become serious as the child grows up. Groves and Blanchard state the problem thus :

As from every quarter new light was thrown upon the meaning of personality, it became increasingly evident, that not only was childhood the golden age for mental hygiene, but that the influence of parents was in most instances predominant in shaping the life of the child. [3]

The fact that the early life of the child, if badly handled by the parent, becomes a fixed source of trouble for the adult in his later coping with life reveals how largely the consummation of mental health depends upon the wholesome interplay of family members and upon a wise parental policy. [4]¹²

To become a socially acceptable human being, a person must be able to meet unfamiliar situations and to absorb hard knocks and rebuffs. He should be trained to face reality and to avoid sympathy-seeking and fantasy-thinking. Parents who overwhelm their children with sympathy and solicitude every time they hurt themselves slightly (such as kicking a chair and saying "nasty old chair" when the child has tripped) are building infantile reactions which may produce severe handicaps in adult life.

Mary and Bill, two only children, were left alone together in charge of a nurse while their parents took an all-day auto trip to the mountains. Mary's parents in fact sneaked out so that she would not notice their departure. When they returned about dusk, Mary's parents rushed up and with baby talk asked her if she had been terribly lonesome without them. Actually she had played very contentedly, but after this greeting she set up a howl which lasted two hours. On the other hand, Bill, whose parents simply walked in as if from the next room, looked up briefly and then resumed his playing.

¹¹With the exception of physical causes, which can occur at any time of life, we have chosen to outline the discussion in terms of the various age levels, rather than by means of symptom classification.

¹²Groves, E. R., & Blanchard, P. Introduction to mental hygiene. New York: Henry Holt & Co., 1930, p. 95.

Symptoms of maladjustment manifested in childhood or later are: a tendency to blame others; attitudes of hostility, suspicion, and jealousy; irritability and bad temper; exaggeration of slight illnesses; and continuation of infantile behavior into later years.

Behavior problems are so varied in nature that one investigation disclosed that the most frequent complaint was encountered in only 12 per cent of cases. The most common problems in a child clinic during a five-year period are those listed below. [13]

Disobedience, negativism, stubbornness	Fears
Nervousness	Excessive phantasy
Temper	Restlessness
Stealing	Cries easily
Truancy, home and school	Masturbation
Lying	Unhappiness
Feeding difficulties	Fighting
Does not get along with other children	Sibling jealousy
Retardation in school	Sensitiveness
Enuresis	Reading difficulties
School failure	Obscene language
Speech difficulties	Quarrelsomeness
Disturbing behavior in school	Lack of concentration
Finger sucking and nail biting	Developmental testing
Placement, adoption	Destructiveness
Overactivity	Mental retardation
Shyness, withdrawal	Staying out late
Sleep disturbances	Laziness
	Physical defects

The family situation is of utmost importance in giving a normal shape to the child's personality development. Each child should be assigned certain tasks, no matter how simple or slight they may appear from an adult viewpoint. Thus, the child becomes accustomed to accepting responsibility, authority, and discipline as matters of course, and later conflicts are minimized. A division of disciplinary authority predisposes toward willfulness.

Bennie's family wondered why their efforts to punish him were of no avail. Night after night he was sent upstairs to bed without dessert, but he didn't even seem to care. One night the mystery was solved when his mother caught the grandmother sneaking up the backstairs with a piece of pie twice the regular size, as soon as the family had left the table.

If authority is not consistent, children learn to play off one parent against the other. Quarrels between parents are upsetting in various ways: (1) because of the general atmosphere of tension; (2) because

furnishes as much opportunity for social development as for intellectual. For this reason it is a mistake for wealthy parents to keep children out of school or to provide them with private tutors, so that they need not associate with "common" boys and girls.

For the first time, the growing child realizes that he is being compared with others, in grades within the classroom and in games on the playground. Children who do not keep up with others often acquire a sense of failure, partly because of a realization of inferiority and partly because of gibes from classmates. One writer says that the school actually *makes* problems for the slow learner. The larger and more progressive schools provide for those who are not gifted intellectually through vocational training curricula.

4. Adolescent Conflicts

Much has been written of adolescence. It has been called the "awkward age." It is assumed to be a period of storm and stress. Physical changes attending puberty are supposed to form the basis of these internal conflicts, but in the author's opinion the conflicts are greatly exaggerated. During early high school years the child's social environment suddenly widens. Previously he went to school in his own neighborhood, came home to lunch and again after school, played in his own yard or immediate vicinity, and did not go out after supper except with his family. Now he goes to high school, perhaps at a farther distance, usually stays there for lunch, and need not come home immediately after school. In the evening he may go to a movie or a dance with friends of both sexes. Problems of relationships between boys and girls, such as dating, popularity, appearance and attractiveness, dancing skill, and family finances are thus introduced. Those who are not popular find themselves at a disadvantage not encountered in the prepubertal days. Girls, especially, become painfully cognizant of their clothes, their physical development, their brother's boisterousness, and they are likely to compare their father's dress and manners with those of their favorite movie hero.

At this age individual differences seem to widen. In addition to social matters, differentiation appears between those of potential college aptitude and those who cannot cope with high school work. In grade school only the feebleminded are seriously retarded. Failures in high school often cause severe emotional upsets. Occasionally we see a newspaper account of a high school student who has committed suicide because of a failure in school. In these cases, the failure is usually coupled with severe parental disapproval. Many children, regardless of effort, cannot assimilate higher learning. To force them to struggle against

overwhelming odds with high school or college work is unfair. Parents should frankly and calmly recognize such scholastic limitations, conceal their own disappointments, and tactfully guide the child toward an occupation with fewer intellectual demands. He should be encouraged to capitalize upon his strong points and not be forced to compete in activities in which he is handicapped.

Most boys and girls escape serious difficulty. Those who are fortunate in personal attractiveness and in their family's economic and social position, those whose parents have inculcated a realistic view of things, and those who are "tough-minded," go through this period without special conflicts.

However, sex difficulties do exist quite frequently. In these cases the fault is almost invariably the parents'. The causes are generally: (1) ignorance; (2) emotional attitudes surrounding the subject. They amount to the same thing: the parents cannot or will not help the growing child attain a balanced orientation. They may not give any information whatsoever or they may avoid direct queries by denials or vague subterfuges. Because of this suppression the child begins to believe that the subject is inherently dirty and nasty. Here is such a case:

Mary's early childhood was spent in a home where parental disharmony was acute. After her birth, her mother refused to have further marital relations with her husband, and the latter turned to other women for the satisfactions denied him by his wife. Mary was a witness to frequent quarrels between her parents until her father left home permanently when she was eight years old. Her mother became embittered, domineering, and refused to let her bring home girls to play with, and later to have anything to do with boys. At the age of 15 she met a man of 35, married him three days later, chiefly to escape the severe domination of her mother. She refused to have sexual relations with her husband; spent two nights sitting on the floor, and returned home. Soon thereafter she began to act peculiarly; she complained that men on the street were annoying her. Even in a hospital she complained that the doctors were trying to have immoral relations with her.¹⁴

The home situation suggested that sex and marriage were inherently unpleasant, and there was no opportunity for development of normal heterosexual attitudes.

Definite harm is done to thousands of high school students yearly by well-meaning individuals, possessed of good intentions but inadequate knowledge of adolescent psychology, who give hygiene talks featuring horror rather than constructive information. Countless boys and girls

¹⁴Adapted from Groves, E. R., & Blanchard, P. *Introduction to mental hygiene*. New York: Henry Holt & Co., 1930, p. 50.

have had feelings of guilt inculcated because of slight or imagined misdeeds because they have been sexually curious, have masturbated, or because they fear the consequences of a kiss. Here is an illustrative case.

A young man of twenty-four seemed to be becoming abnormal for no reason. His particular symptoms were that he was afraid to walk down the street for fear someone was looking at him; he hated to walk to work, or even to leave his own house. His family drove him to work, and he dashed from the curb across the sidewalk into the store, where he felt more confident. He never had a date, nor would he go out with other men more than occasionally. Conditions were growing steadily worse when a psychologist was consulted. The whole thing was traced back to hearing several lectures in the YMCA while in high school which led him to believe that he was going insane because of what we know were perfectly normal sex manifestations. He felt that everyone walking along the street could recognize him and his (imagined) shame as if he were branded. When straight facts were explained to him one could almost see a load lifted from his shoulders, although naturally a complete cure could not be expected for several months.

Cases such as these explain the origin of many marriage difficulties. Boys and girls who have been taught to regard sex as unmentionable cannot experience a complete change during a ten-minute marriage ceremony.

That difficulties of adolescence are avoidable was demonstrated by the findings of a fascinating study done in the Samoan Islands by Margaret Mead. [17] She spent a year studying adolescent girls in one of the more remote islands. Since their houses are thatched roofs with supporting poles but no sides, from childhood they have witnessed birth, death, sex relations, and all physiological functions. They discuss sex as freely as we might a dance or a party. Dr. Mead says: "Familiarity with sex, and the recognition of a need of a technique to deal with sex as an art, have produced a scheme of personal relations in which there are no neurotic pictures, no frigidity, no impotence, except as the temporary result of severe illness." As a result of this frankness and opportunity to acquire knowledge, there is no adolescent conflict among the Samoans. To be sure, we cannot transpose Samoan attitudes and practices into our own society, but the ease with which the Samoans pass from adolescence to maturity is an argument for sexual frankness compatible with our moral code. Sex is a function like digestion or circulation of the blood. It should be treated frankly, rationally, and with neither more nor less emphasis than other topics.

Delinquency and criminality may originate at any age, but the con-

duct itself or its predisposing causes occur so often in adolescence that it seems logical to discuss the topic here. About half of first arrests and a large majority of car thefts concern youths under twenty-one. Thoughtful psychologists believe that delinquency is evidence of maladjustment. Maladjustment reflects a complex set of symptoms by means of which the individual expresses his desires and gains his satisfactions. For example, extreme poverty does not produce delinquency *per se*, but when home conditions are so undesirable that it is unpleasant to remain there, a youth frequents the street and often encounters evil influences. Since he is deprived of material possessions, he may turn to petty thievery and in turn to more serious crimes. Homes in which parents do not live together harmoniously produce several times the delinquency found in more normal homes. Stepparent situations, in which the child is badly treated or neglected, provide a predisposition to crime. Living in slum areas or too near the heart of a large city is disruptive of normal living and development. For instance, in Chicago there are three high delinquency areas: near the Loop, near the stockyards, and near the steel mills. The ratio of arrests in these districts may be twenty times greater than that found in the residential suburbs.

Neglect of children by parents produces much delinquency. The following case is illustrative.

Boy, 18, caught robbing a house. Confessed to entering about twenty others, had stolen mostly articles of small value. It was highly symptomatic that when heard in court neither parent accompanied him. Apparently his father, a professional man in not very good circumstances, was working day and night to keep the family going. Mother played bridge afternoon and evening, and boy was allowed to run loose. In order to compensate for a mediocre intelligence and consequent low school grades, the boy obtained false glory by bragging about his illegal adventures.

Some people break the law not through sheer willfulness, but because they are often driven to it by unfavorable environmental forces. For this reason the psychological aspects of delinquency should be studied, and new ways of handling criminals formulated.

5. Problems of College Age

(A) NECESSITY OF MENTAL HYGIENE PROGRAMS IN COLLEGES. Just because a person has sufficient intellectual ability to go to college, it should not be assumed that his personality and emotional development are superior. In fact, the best adjusted person (on the average, of course) is the one of average mentality; those much higher or lower more frequently have personality disorders.

Since it is the duty of colleges and universities to train future leaders, students should be enriched not only intellectually but socially and emotionally. Since college students are in a transitional stage between home care and mature independence, during these important formative years they can profit especially by a mental hygiene clinic designed to help them conquer minor maladjustments.

(B) **SOURCES OF DIFFICULTY.** In addition to problems arising from physical factors, certain difficulties are especially characteristic of people of college age and in college environments. These fall into two groups: difficulty in adjusting to a new and more complex environment; difficulty in breaking away from home ties.

(1) *Transfer from home environment.* With many students, entrance to the university furnishes the first taste of personal independence and responsibility. College should represent an intermediate stage between the complete dependence of youth and the economic world of independent existence and struggle for survival. For this reason it is undesirable for a college to shelter its students excessively; yet many freshmen do have difficulty in assuming responsibility without regulation by parents or teachers. Class attendance is more or less optional, hours of study are not regulated, and movies or dates are an individual problem. Boys are seldom required to return to their rooms at a certain hour; girls must usually report to the dormitory at a time more in keeping with bedtime than study hours. No one tells students when to change clothes, take out their laundry, or clean their rooms. Small wonder it is that some fail to adjust, especially if parents have been oversolicitous, as in Jack's case.

Jack, a freshman, was reported at midsemester marking period as failing in most of his work, and his attendance was very irregular. Investigation disclosed that he wasn't ill-willed at all, but no one told him to go to class, so he played tennis and otherwise consumed his morning hours. When matters were reported to his parents, his mother wrote back to the dean that he shouldn't be condemned too harshly, as he must be having trouble adjusting. She said that in high school she allowed him to sleep until the last moment, drew his bath, then awakened him, laid out his fresh linen, and brought his breakfast to his bedroom. She suggested that the university should furnish someone to awaken him each morning.

(2) *Larger social group.* Transfer from the home environment is often complicated by the process of becoming a member of a larger community. The transition is more difficult for students from small towns than for those who have attended a large city school. The city student has less academic supervision; he may take a bus to school, stay

there for lunch, and have more freedom after school hours. This comparative freedom encourages independence and self-reliance.

(3) *More intense competition.* In a university the competition is obviously more severe than in high school. This situation often results in dangerous deflation of the ego. Students who have been valedictorians, prom leaders, or football captains are not only no longer prominent, they may actually be neglected. The student should be trained to meet the added demands, and he should realize that he cannot expect immediately to rate as highly in an expanded environment. Parents should realize this fact also, since they often increase the student's feeling of failure by insisting upon consistent performance. Even high school principals occasionally blame the university when their former A and B students get only a C average in college. Such a drop is to be expected. The subject matter is more difficult and the competition is greater.

Conflicts aroused by causes such as these are responsible for many visits to the university infirmary.

Irene entered the university, but her intelligence score showed that she was not really fitted for higher learning. Gradually she fell more and more behind in her work, and accumulated failing grades in her courses. She stayed up late at night trying to keep up, drank an excessive amount of coffee, finally had hysterical outbursts and was taken to the infirmary. At first it appeared to be a simple case of overwork, but after she had paid several visits to the hospital for a week at a time, it became evident that she was trying to do work beyond her capacity.

(4) *Failure to break family ties.* This is a common cause of maladjustment in college students. They are overdependent upon their parents and have not developed mature personalities. They cannot become oriented to their new independence, and they do not assume responsibility or initiative. It does not matter whether the student is living at home or is away at school. He may be emancipated right in the same house or dependent a thousand miles away. Symptoms of dependence include writing long letters each day, telegraphing parents for aid in making minor decisions, going home every week end, and hesitating to make slight purchases without parental authority. One boy went home every week end for four years; even when his fraternity had a dance he went home Friday and returned Saturday evening. One girl bought her supply of ink during vacations and carried it back five hundred miles in her suitcase.

Overdominant parents may have just the opposite effect; the student will rebel against university authority as a way of defying his parents.

usually without realizing the reason. Overcutting and breaking of social regulations are often traced to this sort of mechanism, with the instructor or dean standing in place of the order-giving parent.

(5) *Social adjustments.* Especially in connection with dating and fraternity membership, social adjustments are sources of difficulty to many students. Again it is a question of competition. The girl may have had many admirers in high school, but she does not attract boys in the university. One college girl tried to commit suicide because she had been Prom Queen in high school and had only three dates during her freshman year. Others adjust more normally by making themselves attractive socially or by engaging in other types of activities. Parents are unwise to emphasize the importance of fraternities and sororities beyond their normal value simply because they wish to tell their friends what organization their child has joined.

Outside activities present further problems of adjustment. Some students wish to participate, but fail to take the initiative. In high school a teacher or parent applied pressure, but in the university no one is likely to be urged. As bad a situation arises if the student has too many activities. On every campus there are a few students who are in everything from athletics to debating. To derive the most benefit the student should choose wisely and restrict himself to one or two extracurricular activities at a time, in order that neither the activity nor studies need be sacrificed. "Nervous breakdowns" affect the most capable college people, not so much because of amount of work undertaken as because of multiplicity of stimuli.

(6) *Conflict of ideas.* Problems of religion, sex, economics, and vocation upset some students so much that their work and emotional balance suffer materially. Students should attempt to solve each problem to their own satisfaction. But while they are seeking a solution, they should remember that the same problems face each student and that there is nothing peculiar or unique in their dilemma.

(7) *Minor problems.* In the sense that they are more transitory, finances, health, and study efficiency are minor problems. As to the first two, we would suggest that a student who must engage in excessive outside work for self-support or who is below par in health should carry a reduced program. If he wishes to derive profit from a college education, it is better to do well in a few courses than to do a mediocre job with a full load. Poor study efficiency is caused by any of the above listed difficulties, plus emotional conflicts of any sort. Girls have been known to fall behind in their work, then cry for hours about it, instead of spending the time in catching up. Failure to concentrate is evidence of conflict of some sort. In many cases, however, psychological analysis

is beside the point; the student merely, in plain words, lacks "guts." Instead of forcing himself to study, as a tired runner forces himself to continue a race, he finds excuses for not doing so.

6. Maturity

Possibly the most prevalent sources of difficulty arising in adult years are vocational uncertainties and failures, family troubles, and marital maladjustments.

(A) VOCATIONAL UNCERTAINTIES. These involve choice of an occupation; subsequent uncertainty concerning the wisdom of that choice, and worries about failure to advance. Much attention has been paid to the plight of the unemployed and strenuous efforts have been made not only to keep them alive, but to maintain their morale through work relief. The theory has been that constructive work, even if not entirely necessary, conserves the worker's skills and makes him better able to resume employment. No special attention has been paid to the large group of employed people, who, although they have retained their positions, have not received an advancement in salary for years. Such a condition often produces the loss of motivation discussed in Chapter VIII.

Working conditions that foster unhealthy attitudes are: monotonous or uncongenial work, inability to do original thinking and planning, thwarting of ambitions, excessive routine, failures and inferiorities based upon lack of ability, and long continued unemployment. [23] Unemployed people were found to have more radical or unconventional attitudes toward employers, religion, and general occupational morale. [7] Unemployed men tended to disagree strongly with, and often made bitter remarks about, such statements as "Most companies are genuinely interested in the welfare of their employees" and "Any man with ability and willingness to succeed has a good chance of being successful." Schoolteachers, who naturally play an important part in forming the personalities of youth, have difficulty in maintaining normal personalities themselves. They receive low salaries, out of proportion to the status they are expected to maintain, and they are subject to numerous restrictions in dress, social activities, personal adornment, and recreation. [23]

(B) DEPENDENCE UPON THE FAMILY. This is even more unhealthy when it is continued beyond adolescence and into adult life. Being "tied to mother's apron strings" is a symptom of arrested personality development. When a boy or girl remains at home after graduation, he may fail to mature further, may withdraw from social contacts, and may form such an abnormal attachment to the parents

that the individual remains single. Instances of such symptoms are: man, thirty-five, calls up his mother by long distance every night while away on business; single man, forty-five, refuses all invitations unless his mother is included; girl, twenty-five, has to call up her mother after arriving at a party and just before leaving for home, even when only a few blocks away.

I hope the reader has not misinterpreted these suggestions about the role of parents and the necessity for sons and daughters to become emancipated from the home. Love and respect for family is to be encouraged, but like smoking or golf, it should have limits. Oversolicitude on the part of the parents may be worse than neglect. An adult must learn many things through trial and error, and independence cannot be attained if he lives at home and his parents make all his decisions. It is sometimes recommended that a person get a separate apartment some distance away from his home and see his parents only once or twice a week. Of course, the desirability of this depends upon the individual himself and the attitude of his parents.

(C) **MARITAL DIFFICULTIES.** Marital difficulties are usually the result of unfavorable early training and development. For example, an investigation showed that four times as many only-children were divorced as people from larger families. Spoiled children are willful and refuse to compromise differences. People enter marriage with different backgrounds, experiences, family relationships, hopes and ambitions. Many of them hope in a vague and passive way that things will turn out all right, just as one hopes it will not rain on the day of a picnic. Marriage should be approached with understanding and with a mutual desire for its success. Each person must compromise frequently, repress his own desires at times, and do many things about which he is not enthusiastic.

Inhibitions concerning sex may have been so deeply planted during childhood and adolescence that the person (usually the wife, since girls are subjected to more of these influences) cannot adjust himself to the marital state. As pointed out earlier in this chapter, such adjustment requires weeks or months; the marriage ceremony alone is inadequate. After marriage, home ties of both parties must become secondary; the partner takes precedence over parents. The wife should not compare her husband to her father, to the former's discredit, nor should the husband boast about his mother's accomplishments.

(D) **PROBLEMS OF OLDER AGE.** Certain readjustments should be made as a person grows older. Many men occupy virtually all their waking hours with business. When they retire they have nothing to do, and as a result they become melancholy. Each person should develop

hobbies which may serve as centers of interest when he retires. This is even more necessary in the case of parents whose households dwindle as their children grow up, accept positions, and marry.

Interests also change with age. Most young men enjoy sports of various sorts, but with advancing age, physical exertion becomes less and less attractive and possible. Ten years after graduation from college a man finds himself desiring and needing only half as much physical exercise. Reading, music, and carpentry are hobbies that one does not readily outgrow. If a person has an active mental life, the mature years will be as full as the youthful ones, with the lessening of physical vigor compensated for by greater experience and accumulated knowledge. Many elderly people demonstrate enthusiasm and mental alertness equal to that of persons several decades younger.

7. Treatment of Mental Hygiene Problems

In handling difficulties such as we have outlined, each case should be diagnosed and treated separately. Human emotional problems cannot be handled mechanically or by a formula. However, there are certain frequent causes of upset that suggest treatment along reasonably well-established lines. A few examples are only-child problems, jealousy in older children, failure to develop self-reliance because of overindulgent parents, and inferiorities occurring when attainments fall short of aspirations. No two cases are exactly alike in causation and method of handling, but we can start with a general understanding of each.

Let us emphasize again that we are not dealing with serious disorders needing psychiatric assistance. Usually they are minor difficulties from the standpoint of society, although to the individual himself they may be quite distressing. In many cases the treatment consists simply in getting the person to adopt a different outlook or to face a problem squarely.

Attempts to help people often meet with resistance because the difficulty has been rationalized and a solution has been effected through a flight from reality. The neglected person who develops a functional illness and thus becomes the center of attention and solicitude in the household has solved his problem, even at the expense of travel and social participation. Such a person feels that he has gained more than he has lost. He may unconsciously resist attempts to help him, even though outwardly he may chafe at the limitations imposed by the illness. Before such a person can be cured he must become convinced that his behavior is a handicap and must truly desire to be cured. In such a case the symptom itself may be of no real consequence. In the adult, nervousness may result in stammering, nail biting, inability to sleep, or any one of a dozen other possibilities. Children may bully

and fight other children; we should try to discover what the behavior symbolizes. Fighting may represent a desire for recognition on the part of a child who has been repressed at home. If the fighting habit is cured, breaking windows, truancy, or another attention-getting mechanism may be substituted.

An outline of constructive mental hygiene suggestions follows. [16]

1. *Health.* If a person does not have energy and stamina to cope with trying situations, he will be an easier prey to maladjustment and neurotic tendencies.
2. *Face Reality.* Everyone should learn to behave in terms of his environment and to meet events as they happen. Avoid excessive flights from reality, such as fantasy thinking and constant reading, and keep in contact with social affairs. He should accept unavoidable limitations, such as physical defects or mediocre ability, and reconcile his ideals and ambitions with attainable goals. Maladjustments of the latter type may be forestalled if parents do not set impossibly high goals. Finally, he should cultivate the capacity to make and abide by decisions without vacillation and hesitation.
3. *Be Objective.* See yourself as others see you, and be willing to accept facts about yourself at face value and without emotional bias. Recognize frankly your assets and liabilities; capitalize on the former and attempt to overcome the latter. Admit faults and mistakes; accept criticism calmly. Place the blame where it belongs; do not attempt to shift it from your shoulders to others or to "luck." Don't take refuge in substitute situations or in self-pity.
4. *Deliberately Build Up Desirable Habits.* No one can overcome stage fright by avoiding public speaking, nor develop sociability by shunning groups, nor lose fear of dark by never leaving brilliantly lighted rooms. Practice the habit itself, and each experience will bring you nearer to the desired goal. Realize your assets; do not brood over minor liabilities.
5. *Develop a Sense of Proportions.* Take a sane view of things; avoid exaggerating the significance of experiences and situations, and evaluate each in its proper importance. Remember that the world does not revolve about you, and so forget minor mistakes and embarrassing incidents. Others will forget them quickly; do the same yourself and avoid excessive brooding. A useful procedure is to ask: What will this amount to a year from today? If your job doesn't pay well, remember that millions are entirely out of work. You may have a bad headache, but thousands of incurable invalids would gladly exchange places with you.

6. *Cultivate a Sense of Humor.* The person who can smile and laugh at his awkwardness, his mistakes, and his misfortunes is better able to approach solution of difficulties in a constructive manner.
7. *Turn Your Thoughts Outward.* Be interested in people and things and avoid the excessive brooding characteristic of the neurotic and the extreme introvert. A person retains balance if he is able to disperse pent-up energy by resolving a difficulty rationally or by getting rid of it through violent exertion. Exercise, for instance, relaxes both physically and emotionally.
8. *Have Definite Ambitions.* It is necessary to have goals to strive for, whether of pre-eminence, financial gain, social service, or athletic superiority. The goal should be set within reasonable limits of attainability. The greatest satisfaction is derived from activities based upon one's own initiative, rather than those undertaken passively or as a spectator.

We append a final case to illustrate the importance of having some definite ambition.

Boy, now 20 years old. Slight in build, but good in athletics. But he had bitter moods, often being morose, sullen, and silent. His high school work was erratic, much of his time being wasted. Occasionally he displayed a temper tantrum, one of which outbursts caused him to be dismissed from school.

The family situation seemed responsible, although no teacher associated the two. Father inclined to drink, older sister divorced and embittered. Two older brothers led "fast" lives.

A wealthy man fortunately took an interest in this boy, and asked him to take charge of a ski club for the delinquent and underprivileged children in the town. Our boy took great interest, did much more work than necessary, built up the club in fine shape. His participation and leadership activities caused him to drop questionable behavior, and come back to school in the fall with new enthusiasms and ambitions, graduating at the end of that year with a good record.

In this case the sympathetic interest of one individual, plus the granting of responsibility, changed his attitude toward life from destructive to constructive.

REFERENCES

1. Adler, A. A study of organ inferiority and its psychical compensation. *Nerv. ment. Dis. Monogr. Ser.*, 1917.
2. Freud, S. A general introduction to psychoanalysis. New York: Liveright, 1935.

3. Groves, E. R., & Blanchard, P. Introduction to mental hygiene. New York: Henry Holt & Co., 1930. P. 95.
4. Groves, E. R., & Blanchard, P. Introduction to mental hygiene. New York: Henry Holt & Co., 1930. P. 99.
5. Groves, E. R., & Blanchard, P. Introduction to mental hygiene. New York: Henry Holt & Co., 1930. P. 50. Condensed from original.
6. Haines, W. W. High tension. Boston: Little, Brown & Co., 1938.
7. Hall, O. M. Attitudes of employed and unemployed engineers. *Person. J.*, 1933, 12, 222-228.
8. Hart, B. Psychology of insanity. New York: The Macmillan Co., 1931. P. 131.
9. Howard, F. E., & Patry, F. L. Mental health. New York: Harper & Bros., 1933. Preface; pp. 183, 411.
10. Jones, E. Psychoanalysis. New York: Cape and Smith, 1929.
11. Klineberg, O. Race differences. New York: Harper & Bros., 1935.
12. Leonard, W. E. The locomotive God. New York: D. Appleton-Century Co., 1927.
13. Lowrey, L. G., & Smith, G. The institute for child guidance. New York: Commonwealth Fund, 1933. (See Shaffer, p. 443.)
14. Maslow, A. H. Personality and patterns of culture. Chap. XXII in Stagner, cited below.
15. McKinney, F. Personal mental hygiene in psychological instruction. *Psychol. Exch.*, 1936, 4, 179-186.
16. McKinney, F. An outline of a series of lectures on mental hygiene for college freshmen. *J. abnorm. (soc.) Psychol.*, 1934, 29, 276-286.
17. Mead, M. Coming of age in Samoa. New York: William Morrow & Co., 1928.
18. Menninger, K. A. The human mind. New York: Garden City Publishing Co., 1930. P. 6.
19. Menninger, K. A. The human mind. New York: Garden City Publishing Co., 1930. P. 71.
20. Moss, F. A. Applications of psychology. Boston: Houghton Mifflin Co., 1929. Especially Chapter XI and page 204.
21. Seabury, D. What makes us seem so queer? New York: McGraw-Hill Book Co., Inc., 1934. P. 200.
22. Sears, R. R. Experimental studies of projection: I. Attribution of traits. *J. soc. Psychol.*, 1936, 7, 151-163.
23. Stagner, R. Psychology of personality. New York: McGraw-Hill Book Co., Inc., 1937. Chapter XXI.
24. Van Waters, M. Parents on probation. New York: New Republic, 1927.
25. White, W. A. The origin, growth and significance of the mental hygiene movement. *Science*, 1930, 72, 81.
26. White, W. A. The origin, growth and significance of the mental hygiene movement. *Science*, 1930, 72, 79.

27. Wright, V. C. Personality analysis of college students by the methods of tests, inventories, and autobiographies. Ph.D. Thesis Madison: Univ. of Wisconsin, 1931. Pp. 279 f.
28. Myerson, A. The psychology of mental disorders. New York: The Macmillan Co., 1928.

GENERAL REFERENCES

- Baker, H. J., & Traphagen, V. The diagnosis and treatment of behavior-problem children. New York: The Macmillan Co., 1936.
- Cole, L. Psychology of adolescence. New York: Farrar & Rinehart, 1936.
- Groves, E. R., & Blanchard, P. Introduction to mental hygiene. New York: Henry Holt & Co., 1930.
- Howard, F. E., & Patry, F. L. Mental health. New York: Harper & Bros., 1935.
- Link, H. C. The return to religion. New York: The Macmillan Co., 1936.
- Menninger, K. A. The human mind. New York: Alfred A. Knopf, Inc., 1930.
- Richmond, W. V. Personality, its development and hygiene. New York: Farrar & Rinehart, 1937.
- Seashore, R. H., & Katz, B. An operational definition and classification of mental mechanisms. *Psychol. Rec.*, 1937, 1, 3-24.
- Shaffer, L. F. The psychology of adjustment. Boston: Houghton Mifflin Co., 1936.
- Stagner, R. Psychology of personality. New York: McGraw-Hill Book Co., Inc., 1937.
- Symonds, P. M. Mental hygiene of the school child. New York: The Macmillan Co., 1935.
- Young, K. Social psychology. New York: Alfred A. Knopf, Inc., 1930.

*INDIVIDUAL DIFFERENCES AND
INTELLIGENCE*

XIV

INDIVIDUAL DIFFERENCES

1. The Nature of Individual Differences

Individual differences in ability have always existed. In Greek legend Hercules is described as extraordinarily powerful, Ulysses as the wiliest of men, Achilles as an invincible warrior. Characters of history and romance are characterized by their unique excellencies or deficiencies; in short, by their differences from that hazy abstraction, the average man. The Greeks and Romans eliminated weak or feeble-minded children by exposing them to the elements. Among the American Indians, and in primitive societies generally, the unfit were not spared the rigors of life. When food was scarce, the strong were fed and the weak allowed to wander off into the wilderness. Not until after 1800 did people develop a sympathetic attitude toward the deficient and the insane. Not until the beginning of the twentieth century was the first true test of intelligence devised.

We differ widely one from another. Some of us are graduated from college and enter the professions; others finish a few grades of primary school and begin to work as clerks or laborers. We differ in our choice of vocations, friends, sports, religion.

These differences are studied in *differential psychology*, which includes the entire field of intelligence testing. These tests seek to find ways in which individuals differ from one another, and so this branch of science differs from the majority. The latter search for uniformities and formulate general laws. For instance, the chemist assumes that a formula will work the same way each time specified elements are combined in a certain way. The engineer assumes that the principles of bridge construction used since Caesar threw his famous one across the Rhine will operate in connection with the next bridge he builds.

Human beings, on the other hand, differ from one another not only in external appearance, but also in intelligence and in native ability. No single formula can explain their acts, nor can they be predicted with accuracy. The same treatment—for instance, equal educational advantages—does not produce the same result in various people. If one student who has a 90 average in high school and a high intelligence score earns a B average in college, it cannot be assumed that all other students with similar high school records and intelligence ratings will attain the same degree of college success. Another student, in all outward aspects just like the first, may fail. Testing is not a hopeless task, however; the more we know about a person the more accurate our prediction will be.

Von Helmholtz, famous German physiologist and psychologist, said psychology could not become an exact science because people differ so much that no definite laws can be formulated. Today we recognize these differences and seek to discover their meaning. An examination or an intelligence test reveals who is best and who is only average. In a track race or a golf tournament we search for a winner and eliminate those not so proficient. When we select a store manager we seek the best fitted man among the clerks or applicants. Each person chooses a vocation which promises to give his talents and interests the greatest scope, so that he will have the best possible chance for success. Restaurants serve a variety of foods and stores carry several styles of clothing to cater to individual preferences.

2. Samples of Individual Differences

For purposes of illustration, let us list examples of individual differences in a number of fields.

- (1) Anatomical: height, weight, length of foot, lightness or darkness of complexion.
- (2) Physiological: heart rate, resistance to drugs (as alcohol), acuity of hearing, endurance.
- (3) Simple psychological traits: reaction time in pressing the brake pedal or in dodging a flying object, speed of word association, gracefulness and coordination in dancing.
- (4) Complex psychological traits: intelligence from the lowest feeble-mindedness to genius, speed in learning a poem.
- (5) Personality traits: self-reliance, sociability, poise in an emergency, tact, persistence.
- (6) Interests: hobbies, sports, vocational choice, choice of friends.
- (7) Social outlooks: religious preferences, political party, theories on economics, racial attitudes.

(8) Achievements: scholastic performance, business success, social acceptability.

3. Range of Individual Differences

How widely do people differ one from the other? Are people more or less alike, or are there vast differences? Are the apparent differences truly as great as they seem on first inspection? Are the differences greater for some types of activity than for others?

It is easy to see that differences are greater in some functions than in others. Normal body temperature is about 98.6°; everyone in good health has a temperature almost exactly the same. In contrast, incomes vary all the way from the multimillionaire's to the sharecropper's.

Let us see how human abilities differ in a number of functions. Many of the ratios quoted in Table 19 were gathered by Wechsler, [5] and they are presented as the ranges of groups with just two cases out of a thousand omitted, the very best and the very worst. Since these two cases might be considered freaks, their inclusion would not give an accurate picture of the great majority of the group. Other figures have been added as a result of several investigations by the author.

TABLE 19
DISTRIBUTION OF RANGES OF CAPACITIES

Body temperature.....	1.03 to 1
Stature at birth.....	1.23 to 1
Adult stature.....	1.27 to 1
Duration of pregnancy.....	1.37 to 1
Sugar in blood.....	1.40 to 1
Oxygen consumption.....	1.53 to 1
Weight of brain.....	1.60 to 1
Running 60 meters.....	1.67 to 1
Respiratory rate.....	1.88 to 1
Pulse rate of adults.....	2.03 to 1
Blood pressure.....	2.03 to 1
Broad-jump.....	2.07 to 1
Speed of inserting bolts.....	2.09 to 1
Simple reaction time.....	2.24 to 1
Simple learning.....	2.42 to 1
Card sorting time.....	2.50 to 1
Intelligence quotients.....	2.86 to 1
Hard learning.....	3.87 to 1
Polishing spoons.....	5.10 to 1
Time to learn a maze.....	6.82 to 1
Intelligence scores of high school seniors.....	10.55 to 1

We see from this that some people are two, three, five, and even ten times as effective as others in performing the same task. These ratios are comparatively conservative, since the studies were made with

homogeneous groups. For example, the last figure quoted is for high school seniors, a group which, of course, does not include people who are feebleminded or even slightly dull. The maze learning figures are for a college group, all of whom have better than average ability, come in the main from good cultural environments, and have already assimilated more than an average amount of education. If we had included children, unskilled laborers, or feebleminded, the ratios would have been several times greater.

The figures, studied in terms of the types of activity, show fairly consistent trends. In anatomical measurement variations are slight. We think of a man who is five feet three as very short and one of six feet six as exceptionally tall, yet the ratio is only 63:78, or 1.22 to 1. In physiological measures, such as pulse rate or breathing, the variations are slightly larger. Psychological functions—speed of learning, for example—show still wider individual differences. The more complex and intellectual the function the wider the variations. Differences are greater in personality and intellectual traits than in simple sensory or motor functions, such as acuity of color vision or speed of tapping.

In terms of actual value, the differences are probably far greater than these ratios show. A man may be only a third brighter than someone else, yet he may earn three times as much. A golf professional who averaged 72 strokes for each eighteen-hole round during one winter earned \$7,000, while another who averaged just two strokes poorer got only \$350 of the prize money. Jesse Owens, supposedly the fastest sprinter in the world, was said to be in a class by himself. Yet he won his hundred-yard dashes by only a yard or two. Surely 1 or 2 per cent is not such a vast difference. Yet in terms of medals won he might be said to be ten or twenty times as good as the man who finished a short distance behind him.

4. The Normal Distribution

One of the most important facts in psychology, and one which we shall encounter again and again, is that human traits lie along the *curve of normal distribution*. There are not equal numbers of people with various scores from one extreme to the other. Rather, most people are clustered near the average, with fewer and fewer as we get farther and farther from the average.

Given an adequate sample of people chosen at random, a curve of this shape will appear for virtually any human trait one could measure, whether size of feet, speed of running, or intelligence scores. This is true in spite of the fact that most traits are complex; that is, various forces work upon them in several directions.

The normal curve gives us a useful and practical means of locating and evaluating any particular individual's score. A score means nothing unless it is compared with other scores. For example, you are told that you made 80 on a certain test. You ask: 'What does this mean? We can only tell you how you stand by comparing you with others who have taken the same test. If the average is 70, you rate 10 points better than the average. We know not only that you are superior, but how much so. Care is taken to derive standards from people like yourself. We compare your score with those of other college students, your younger brother's score with the high school norms, and your father's with those made by men of his age and education.

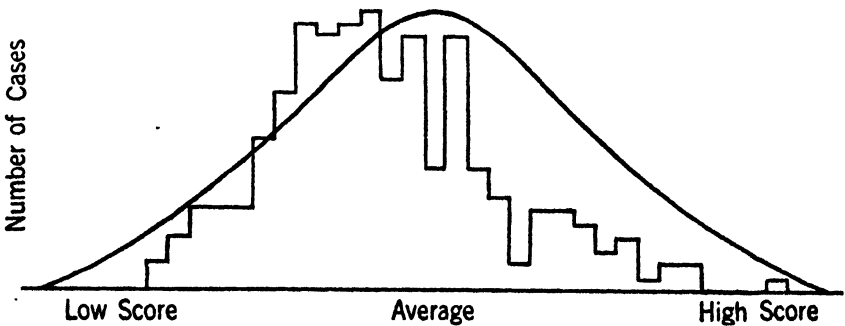

FIG. 35.—A Normal Distribution and an Actual Distribution.

A normal distribution and a distribution actually obtained on a class examination given to about 250 students. The greater the number of students and the better designed the test the closer will the actual distribution coincide with the theoretical one.

For a more accurate estimate we translate your score into a percentile. The poorest person is said to be in the first percentile (written as 1st %ile, or 1 %ile), while the top person is in the 100th %ile. If you were in the 70 %ile, it would mean that you are better than 70 per cent of your group and poorer than only 30 per cent; in other words, that you are 70 per cent of the way to the top. Just to fix firmly this concept of a percentile, let the reader tell himself just how he would locate people who are in the 35 %ile, 52 %ile, and 93 %ile.

Since your performance is always compared with others of your own or a similar group, you should not become discouraged if you are low in a superior group, nor become overinflated if you are at the top of a mediocre population. It is obviously preferable to be near the bottom of a college class than to be valedictorian in a school for backward children. Even the poorer students in college are above the average of the general population in intellectual ability. The higher a student goes in the educational scale, the lower his percentile will be, even though

his abilities remain at the same level. For example, a high school senior who is in the 80 %ile of intelligence scores of Wisconsin high school students will find himself in the 65 %ile of University of Wisconsin students. In general only the better high school students go to the university.

5. Type Theories

Quite often we hear statements such as "The short, fat type"; "He is the perfect salesman type"; "People of that race are either awfully smart or terribly dumb." Also, people are described as beautiful or ugly, stupid or bright, fat or thin, honest or dishonest, as if there were no intermediates between these extremes. Worded in general fashion, such statements suggest that in some traits the normal distribution does not hold, but that people tend to cluster about certain points on the scale like bees about their hives. This is an "either-or" idea, as exemplified in the statement: "A person should either sing well or shouldn't even be allowed to try."

Most of us like to classify, and with inanimate things classification is often beneficial. We save time by filing letters alphabetically, by putting each type of garment in a different bureau drawer, and by making automobile bodies in four or five styles instead of catering to the whim of each individual purchaser.

But with human beings the facts are different. Men are not either average, thin, or fat. Waist measures vary all the way from average to many inches larger or smaller, and every inch, every half inch, and every sixteenth of an inch is represented. Occasionally we force scores into groups, such as marks into A, B, C, or boxers into heavyweights, lightweights, bantamweights. Such divisions are purely arbitrary and do not contradict the accepted principles of the normal distribution. Nor is there such a thing as the "perfect salesman type" or the "typical small-town banker." A survey of small-town bankers would show that they are of all ages and physical builds, attend all churches, belong to various lodges or none, some work in shirt sleeves and others in stiff collars and black coats. If you attend a bankers' convention or a salesmen's meeting, you will find almost as many individual variations as you will if you study the first hundred men you meet on the street. They may have a few points in common—especially their interests and ways of doing routine tasks—but their variations far outnumber their similarities.

Once in a while there may be genuine bimodality (the presence of two peaks in a distribution), but in these cases a divergent factor is usually at work. For example, if we chart the weights of students in a

university, we find a graph shaped like that in Fig. 36. There are two peaks, with a valley between. Why? No doubt many of you guessed immediately. There were two because both men and women were represented. This case does not represent a violation of the principle of normal distribution; we have merely plotted two normal distributions on one chart.

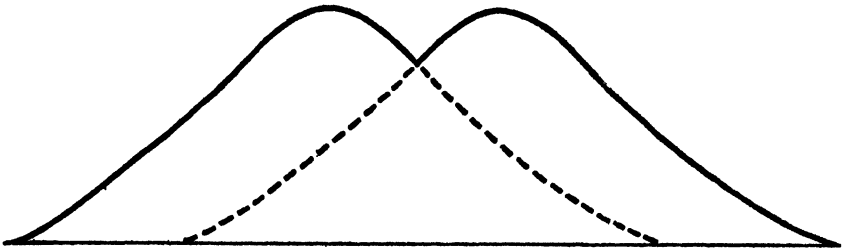

FIG. 36.—A Bimodal Distribution.

Here are two peaks. Rarely does this occur legitimately. Usually it represents, as shown by the dotted lines, two distributions combined together. This might be, for instance, the weights of college students, the two peaks representing men and women.

Bimodality may also appear when there has been a selection of cases. In certain routine tasks, such as messenger boy in a bank or brokerage office, the intelligence scores may disclose bunching at each end. Those at the lower end of the scale remain because they cannot progress any further, while those of high aptitude remain to learn the business from the ground up. The majority of those near the middle of the distribution soon leave, resulting in the bimodal distribution. Highly selected groups show only the upper portion of the normal distribution. Examples are the intelligence scores of college students and the weights of members of a football team.

6. Correlation

To ascertain how well various abilities go together is an important problem in psychology. Is a person who is good at one task likely to excel in other skills as well? Might he even be poorer, because his abilities run mostly to one line? Or is any prediction utterly impossible?

Desirable traits tend to be positively correlated. If a person is superior in some things, it is likely that he will also be better than average in other functions. In some cases the trend is weak and uncertain, in others strong.

A measure of the degree of correspondence is necessary. We know that brighter students earn better grades in school, but there are exceptions. A bright boy may fall in love, become ill, or lose interest, and

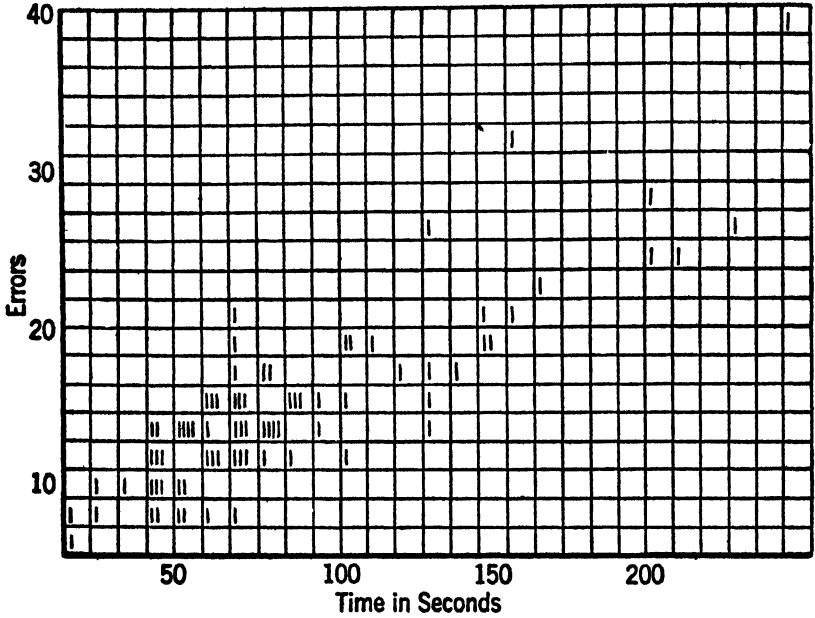

FIG. 37A.

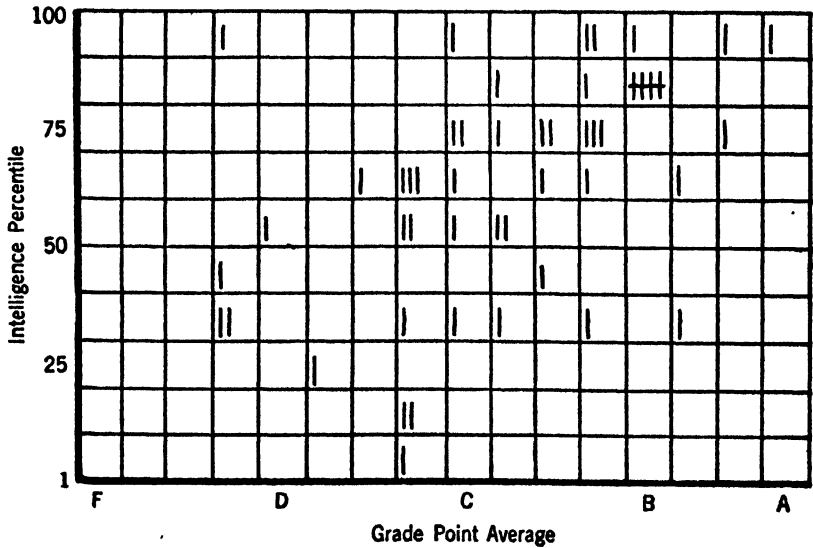

FIG. 37B.

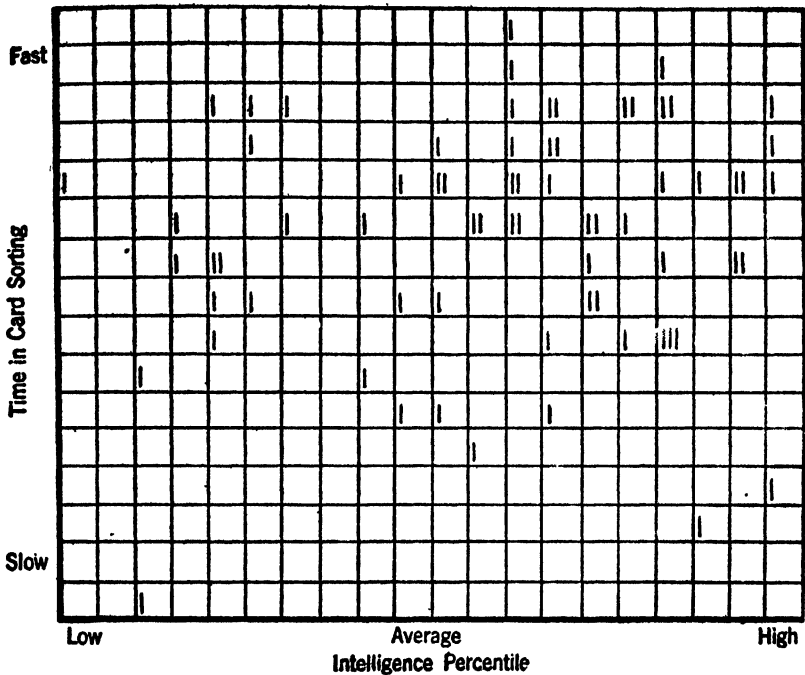

FIG. 37C.

FIG. 37.—Three Sample Correlation Charts.

We have here three correlation charts, showing respectively a high degree of agreement, moderate correspondence, and no correlation at all.

In Fig. 37A we have the correlation between trials and errors in learning a maze. Since both are measures of the same ability, we would expect a high correlation; that is, that a high score would be associated with a high score and a poor score in one variable would be accompanied by a poor score in the other measure. This is borne out by the correlation of $+ .92$.

Fig. 37B shows a good degree of correlation: a figure of $+ .50$, between intelligence scores and freshman college grades. There is a strong tendency for brighter students to earn higher grades, but there are enough cases of disagreement, often caused by bright students' failing to put forth serious effort, to reduce the correlation materially.

Fig. 37C shows a correlation of almost exactly zero between intelligence and speed of sorting cards into the four suits. No trend whatsoever can be detected—a bright person may or may not be fast in this motor act; a person of less native ability may or may not be fast in card sorting.

who are in turn more variable than rats, and as we go down toward the lowest living organisms we find practical uniformity.

(5) Differences increase with age. Children at birth vary, but adults show far wider individual differences. These increase steadily as one matures.

(6) There is relative uniformity among innate and hereditary traits, and more variation among acquired traits.

(7) The more complex the trait the wider the variations. For example, there are far wider differences in speed of learning a poem than in dealing out a deck of cards.

REFERENCES

1. Bingham, W. V. *Aptitude testing*. New York: Harper & Bros., 1937.
2. Ellis, R. S. *The psychology of individual differences*. New York: D. Appleton-Century Co., 1928.
3. Freeman, F. S. *Individual differences*. New York: Henry Holt & Co., 1934.
4. Jenkins, J. G. *Psychology in business and industry*. New York: John Wiley & Sons, 1935. P. 213.
5. Wechsler, D. *The range of human capacities*. Baltimore: Williams & Wilkins, 1935.

XV

THE NATURE AND MEASUREMENT OF INTELLIGENCE

I. MEASUREMENT

1. The Background of Testing

Psychology became a science when measurement began. In Chapter I we saw that the earliest measurements were of the simpler processes, such as speed of reaction, discrimination of weights, speed of tapping, and so on. Individual differences were not considered; in fact, their study was not recognized as a legitimate field of psychology.

In the United States, however, two psychologists measured individual differences prior to 1900. Cattell wrote his Ph.D. thesis at Leipzig on individual differences in reaction time in spite of Wundt's protest that general laws should be sought, not departures. Cattell's tests at Columbia in 1890, using the whole freshman class, were measures not of intellect but of functions like strength of grip, reaction time, speed of color naming, and simple memory. Jastrow of the University of Wisconsin tested thousands of adults by means of similar tests at the Columbian Exposition in Chicago in 1893.

Shortly after 1900, Alfred Binet was commissioned to ascertain the true mental status of retarded children in the Paris schools. It was not certain whether retarded pupils were mentally dull, unwilling to learn, or otherwise emotionally or physically handicapped. Teachers' opinions were formed from a composite of various factors. Binet made two decisions which are still fundamental to intelligence testing: (1) The material of tests must be complex in nature. (2) Tests must be as far as possible measures of native ability or of common life experiences, divorced from school learning. He issued his first scale in 1905, and continued to improve the tests with his 1908 and 1911 revisions.

(His last scale was 1911; he died in 1911.) His general plan has been crystallized into the age level tests now commonly used. In Section III of this chapter we shall examine some of the items in the Stanford Revision of Binet's last scale.

A real impetus to the modern testing movement came at the time of the World War. Psychologists were asked to classify the newly recruited American army in terms of intelligence and aptitude. They devised the famous Army Alpha and Army Beta tests. From a psychological standpoint their chief contribution was in making these tests, group tests and not more or less personal interviews such as the age-level tests are. The new type of tests could be administered speedily to large groups. Nearly two million men were tested, and data on many problems were derived.

2. Construction of Tests

Binet wished to measure native rather than acquired aptitudes. Since his and all later tests call for solving problems and giving answers to various questions, it might seem that there is a contradiction. We are born without ideas or knowledge; yet innate ability can be tested only by means of processes or facts which have been learned.

This difficulty is obviated in part by preparing tests from information which everyone has had a chance to learn. We assume that the tests are fair, since an alert person profits from any situation with which he comes in contact. If a person does not learn routine information, it must be because he is less alert mentally. Care is exercised in choosing items that are not within the experiences of only one group, say city people or farm people, those with ample finances or those who go to college. A farmer who is bewildered by the city is not stupid; he is merely encountering things outside his experience. However, his ability may be displayed by the speed of his adaptation to a new situation.

We are permitted to use school material because every state has compulsory school laws. In all states children must attend school at least until fourteen, in many until sixteen, and in some until eighteen years of age. All children in the United States study certain arithmetic procedures, geography, United States history, and so on. Further, it is assumed that everyone should know who is president, that Lindbergh is an aviator and not a baseball player, and similar items of common knowledge.

When a psychologist wishes to devise an intelligence test, he selects hundreds of items of various sorts. He then tries them on groups of people, being sure to include those from various parts of the country,

from city and farm, and from all social and economic classes. If the test is to be used for a certain age group, such as grade school children, college students, or factory workers, he naturally standardizes his proposed test on that population. Then he chooses those items from the list which the bright people answer correctly. If a dull person has as much chance of getting the correct answer as the brighter individual, the item has no discriminatory power and is discarded. Then the original list of several hundred questions may be reduced to a well-chosen hundred or less.

Time limits are usually set on intelligence tests. The best practice is to set the limit so that no one can finish but everyone can answer at least one question. In other words, we do not want any 100 or any 0 scores. If a person gets 100, we do not know how much more he could have done within the time limits. If two students got 100, one might have just barely finished before time was called, and the other might have finished in half the allotted time. Likewise, one child with a zero score might have been almost ready to write the answer to a problem, while another might not even have understood what he was to do. In order to eliminate the possibility of zero and perfect scores, we set time limits carefully and arrange items in order of difficulty, the easier ones first and so on.

Occasionally a student objects to a strict time limit on tests. He says, "I work more slowly than other people, but I am very accurate." It is true that in intelligence tests there is a premium on speed. The fast-thinking individual has the advantage. But actual research shows that in most cases the fast person is also the more accurate one. When the time limit is removed entirely and each person is allowed all the time he wishes, he occupies approximately the same position in his group as with standard time limits. Thus, "speed" and "power" are highly correlated. This should not be misinterpreted as implying that the faster you go the better you will do. It applies to comparisons between people. If you finish ahead of your friend, the chances are that you also will make fewer mistakes than he did.

3. Tests for Children

Adult tests are usually long, written affairs that can be administered to large groups at one sitting, but with children under twelve individual and oral tests are preferable. Tests for children are set up in age scales. By means of thousands of tests given in different states, in city and country, and on different socioeconomic levels, we know what the average child at each age should be able to do. By definition, the average eight-year-old should be eight mentally. After standards of

mental age have been determined, children may be measured by them. If a child passes all the eight-year tests but no more, he is said to have a mental age of eight years. In determining mental age it does not matter whether the child is chronologically eight, or ten, or six. If he attains a mental age in advance of his chronological age, he is precocious; if he is older physically than mentally, he is retarded. The degree of advancement or retardation determines his IQ, a term which will be explained in the next section.

Binet's 1908 and 1911 scales were arranged on this age-scale basis, [1] and several translation-revisions into English have been set up in the same way. The best known test is the Stanford Binet, originally revised by Terman in 1916, and further revised and improved by Terman and Merrill in 1937. [16] This latter scale contains tests for each year from two to fourteen, average adult (roughly sixteen years mentally), and superior adult (roughly over eighteen years mentally). At each age level there are six tests, each of which gives the child two months' credit. If he passes all the eight-year tests and three of those on the nine-year level, his mental age is eight years, six months. If he passes all the eight-year tests, three on the nine-year level, one on the ten, his mental age is eight years, ten months. The accepted procedure in administering the test is to start at a level one year below the chronological age, unless the child is suspected of backwardness, in which case one might start two or three years below. Testing is continued until he fails on all tests at some level.

Since the test items furnish excellent indices of the mental capacities of children of all ages, by comparing a given child with the norms one can ascertain whether he may be superior, average, or retarded. For instance, the average eight-year-old child should be able to give a meaningful description of the nature and uses of common objects, answer several simple questions about a short story which is read aloud to him, recognize the absurdities in certain impossible situations, tell similarities and differences between common objects, exhibit rudimentary reasoning powers, and be able to recite verbatim sentences of ten or a dozen words. If he can do such tasks he is credited with having an eight-year mentality, regardless of his chronological age.

At younger levels the tasks are accordingly simpler, as consistent with the actually measured capacities of children of the various ages. Recognizing objects from pictures, obeying simple commands, comprehension of simple situations, telling time, giving the opposites of objects, and finding elements missing from pictures are all samples. At the other end of the scale, the average and superior adult must give definitions of more difficult and less frequently used words, abstract

the underlying meanings of proverbs, and reason out rather difficult problems.

4. The "Intelligence Quotient"

(A) COMPUTATION. The comparison of mental and chronological ages suggests the possibility of a ratio. If a child has the same score in both, say eight, his ratio will be 1.00. If two other eight-year children have mental ages of nine and seven respectively, their ratios will be $\frac{9}{8}$ and $\frac{7}{8}$, or 1.13 and .88. The decimal point is customarily dropped, so the Intelligence Quotients of these three children will be given as 100, 113, and 88.

The general formula is written in this way:

$$\text{Intelligence Quotient} = \frac{\text{Mental Age}}{\text{Chronological Age}}$$

So that the reader can see for himself just how the formula is applied, let him do three easy problems. Three boys, all ten years old, have mental ages of 10, 13, and 7 years 6 months. What is the IQ of each?

(B) INTERPRETATION. It is obvious that IQ's above 100 represent acceleration and those under 100 mean retardation or dullness. But how deficient is an IQ of 80? Just how superior might one consider himself if he is told that his IQ is 130? We list in Table 21 the classifications and proportions in each of the accepted levels of intelligence.

TABLE 21
CLASSIFICATION OF IQ LEVELS

IQ	Classification	Approximate Percentage	Maximum Mental Age
0 — 24	Idiot	2	4 years
25 — 49	Imbecile		8 "
50 — 69	Moron	3	11+ "
70 — 89	Dull normal	20	14+ "
90 — 109	Average	55	17 "
110 — 139	Superior	20	20+ "
140+	Potential genius	0.1	?

Of course, these classifications are drawn chiefly for the sake of convenience. Practically, there is no real difference between persons a few points apart. For example, if brothers happen to have IQ's of 68 and 72, this does not imply that one is definitely feeble-minded and the other is capable of getting along satisfactorily. Willingness to work and other favorable personality traits can offset a number of points'

deficiency in intelligence. But such arguments cannot be carried too far. All the hard work in the world will not make a good college student of a person with an IQ of 80.

Another warning about the use of terms. The three levels of feeble-mindedness are not interchangeable. The terms "moron," "idiot," and "imbecile" are interchanged loosely in conversation, but such loose usage is not legitimate. Also, the term "moron" has no moral significance. In private conversation and occasionally even in newspapers, the term moron is used to describe a person guilty of sexual assault. Scientifically, this usage has no justification. A moron has the single characteristic of possessing an IQ between 50 and 69. Immorality appears at every level of ability; the majority of morons are law-abiding.

From the percentage figures we see that over half the people fall within ten points of the average of 100. One quarter lie within five points one side or the other of average. Widely divergent scores are in the distinct minority. Perhaps a fifth of the population is dull normal, but only a few are definitely feeble-minded. Another fifth is superior, but only one in a hundred is above 130. One in a thousand is in the "potential genius" class; one in about 14,000 reaches 180. Only a few cases over 200 have ever been recorded.

(C) LIMITS OF GROWTH. The IQ formula is used largely with children. Since during the long period of adult life a person remains at about the same intellectual level, it would obviously be unfair to base intelligence quotient upon chronological age. Just when, then, does the mental development reach its peak? Most authorities set it at sixteen, and use that as the CA of an adult. A few have set it as early as fourteen, and some feel that eighteen is more accurate, but the great majority of experts prefer sixteen. It is possible that superior people continue to grow until they are eighteen or perhaps older. The average individual reaches his peak at sixteen, and the dull normal even earlier.

This does not mean that adults cannot learn, nor that they are no more efficient at forty than at twenty. Middle-aged men are preferred for positions of responsibility because of their greater knowledge and experience. Their speed in problem solution, however, is no greater than it was in late high school or early college years.

(D) ADULT MEASURES. Since the progress of intelligence with age is an uncertain quantity, we prefer not to quote IQ's for people much over sixteen. Rather, we assign them to a certain percentile (see page 303). This percentile is based upon the actual distribution of hundreds or thousands of scores on the same intelligence test. Thus, if you are average for students at your university, we say that you are in the

50th %ile for students of X University. This will undoubtedly mean that you are well above the average of the general population, since practically all college students are over 100 IQ (estimated from tests they have taken when in grade school), and the general college average over the whole country is in the neighborhood of 110. The norms differ from one university to another, depending upon the region, strictness of admission standards, and type of students attracted.

Similarly, adults are usually compared with others who are employed in the same work or profession. Such comparison, without attempting to ascertain an absolute IQ, is sufficient, since it will determine the person's occupational fitness. Also, percentile may be determined by comparing a score with those of other adults who have taken the test all over the country. These adults may be of one particular class, or they may represent all walks of life, all degrees of education, rural and urban residence, and various intellectual interests.

5. Adult Tests

Tests for adults, college students, and high school pupils are arranged in the same general fashion as examinations, on the written question-answer basis. These tests usually have a number of parts, with an assigned number of minutes allowed for each. For ease of scoring, the person taking the test is asked to mark the correct answer, fill in a single word or figure, or check whether the statement is true or false. This procedure also reduces the time required for writing and leaves virtually the whole time for thinking.

We list below many of the different types of functions tested, and quote a few samples of each chosen from the best standard intelligence tests.

(1) FOLLOWING DIRECTIONS.

Write 4 as many times as it is contained in 20. 4 4 4 4 4

If 6 is larger than 4, put a letter A inside the middle circle and underline "Yes"; if it is smaller, put an S inside the last circle and underline "No."

○ (A) ○ Yes No

(2) ARITHMETIC.

How many hours will it take a truck to go 48 miles at the rate of 4 miles an hour?

Answer (12)

What is the average rate per hour of an airplane which travels 403.2 miles in 3 hours and 12 minutes?

Answer 126 miles

(3) NUMBER SERIES COMPLETION.

Look at each row of numbers below, and on the two dotted lines write the two numbers that should come next.

6 9 12 15 18 21 24 27
 15 16 14 17 13 18 12 19

(4) ANALOGIES.

○ is to ◊ as □ is to: 1 ○ 2 □ 3 ◊ 4 ◻ 5 ◻

Historian is to facts as novelist is to: 1 fiction; 2 Stevenson; 3 poem; 4 man; 5 nature.

1 2 X 4 5
 X 2 3 4 5

(5) ARTIFICIAL LANGUAGE. We cannot reproduce actual items from this test, as it calls for extensive directions. One is given a short vocabulary, and certain rules of grammar, such as how to make plurals and verb forms, and is then asked to translate short sentences into English and into this Artificial Language.

(6) VOCABULARY TESTS of various sorts.

An enterprising person is: (1) slovenly, (2) deceitful, (3) rude, (4) aggressive, (5) lucky.

Altruistic—egotistic same opposite

Λ (7) is a cultivator of, or dealer in, flowers.

Good though your intentions may be, the results of such acts are bad.

(4)
 florist

(7) INFORMATION.

Onyx is a: 1 limestone, 2 quartz, 3 glass, 4 granite, 5 metal

Quinine is the name of a chemical element city drug title

Perjury is a term used in pedagogy law theology medicine

1 X 3 4 5

(8) COMMON SENSE.

Gold is more suitable than iron for making money because

- gold is pretty
- iron rusts
- gold is scarcer and more valuable

If plants are dying for lack of rain, you should

- water them
- ask a florist's advice
- put fertilizer around them

(9) COMPREHENSION.

My cousin's mother is my sister's 1 aunt, 2 second cousin, 3 daughter, 4 mother, 5 niece

① 2 3 4 5

months warmest are summer the

true false

(One must rearrange this sentence mentally and then indicate if the statement is correct or not.)

Also there are paragraph meaning tests. A sample would be too long to reproduce here. One reads a paragraph of material several hundred words in length, and then has to answer questions. He is allowed to look back but naturally the more he remembers the faster he will be able to work.

(10) ABSURDITIES—missing elements.



What is wrong in this picture?

II. THE NATURE OF INTELLIGENCE

1. Functions of Intelligence

Instead of attempting a formal definition of intelligence, it seems preferable to present the leading aspects of intelligence as functions. In other words, the points listed below are ways in which an intelligent man behaves, and in which his behavior is distinguished from that of a stupid person.

(A) **ABILITY TO PROFIT FROM EXPERIENCE.** You are driving your automobile and it stops; after quite a long search you find the cause and repair the part. The next day the car stops again under similar circumstances. The bright person will go right to that same part. The dull individual will start afresh, as if the first incident had never occurred. Birds fail to profit from experience when they keep flying at plate-glass windows, not recognizing that, although transparent, they are solid.

The experience from which you profit may have occurred to someone else, rather than to yourself. For example, I will never touch an electrical fixture while in a bathtub, for I had a friend who was killed that way.

(B) **MAINTAIN A GIVEN ORIENTATION.** It is a characteristic of the feebleminded and of many insane that they do not concentrate long on any single topic. The brilliant man can keep his attention fixed over a long period of time.

(C) **VARIABILITY AND VERSATILITY OF RESPONSE.** Stupid human beings and lower animals tend to repeat what has just been done, even though it has resulted in failure. They may try again and again. But the bright person after one or two failures sees that a new attack is necessary and shifts his efforts. The solution of a ring puzzle is an example: one tries to get the two rings apart in what appears to be a logical way, but fails. If the person does not repeat the inadequate approach but changes, that constitutes an intelligent bit of behavior.

(D) **ABILITY TO ADJUST TO NOVEL SITUATIONS.** The more intelligent person adapts with greater speed and more appropriateness when a situation outside his previous experience arises, while the more stupid person relies upon habitual and practiced solutions. The latter fails to take account of items of difference between new and previous situations. This adaptation may be intellectual, vocational, or social.

(E) **ABILITY TO SEE DISTANT RELATIONSHIPS.** This is perhaps the fundamental quality possessed by the scientific research worker and the inventor. Benjamin Franklin combined a natural phenomenon with discovered facts and invented the lightning rod. Undoubtedly other men had the same knowledge, but none of them had seen that particular relationship. Closely akin to this is the ability to generalize. The brighter person will be quicker to perceive that under certain conditions certain results will follow. He can also transfer reasoning from one situation to another. Here is an instance of failure to generalize. A rather dull maid annoyed the owner of the house by throwing away a dozen milk bottles on which a deposit had been made. When it was pointed out that she should have known better, since her family ran a

store, she seemed surprised and said that she had never thought of bottles being worth anything except in a store.

(F) ABILITY TO CARRY ON ABSTRACT THINKING. More advanced mental development is required to think of philosophical concepts than to order a meal, more to do a problem in calculus than to balance a checking account (much as this does trouble some adults), and more to evaluate the fundamental principles underlying a political campaign than to find fault with a candidate's personal mannerisms. To alter slightly one of our axioms of individual differences, we might say that the more complex the function the greater the differences between bright and dull people.

(G) CAPACITY FOR INHIBITION OR DELAY. In comparing animals with men we noted that only man and monkeys could negotiate any material delay and still solve a problem. The same difference distinguishes bright and dull human beings. Social workers frequently discover that families on relief are not able to spread their money over the period between paydays; they often spend their allowance immediately and cannot buy proper food the rest of the week. In other words, it takes intelligence (as well as inhibition) to build up a savings account, to save for Christmas expenses, for next summer's vacation, for possible illness, for new clothes or a new car, or for old age.

(H) SELF-CRITICISM. To improve upon your own work represents intellectual acumen. You are exercising this function when you revise an English theme or rewrite a letter of application for a job. The less alert individual will dash off something and not realize that it might be improved.

2. Intelligence Largely an Innate Function

Ever since Binet began to study the intelligence, it has been considered an innate ability. Binet wanted to know if retarded children *could not* keep up with their classmates. Other tests are designed to find which candidates for college can master courses in higher education, which applicants for positions can handle the work demanded, and which delinquents cannot earn an honest living. Clinicians constantly try to distinguish the causes of failure. Some people do not try hard enough and some have unfortunate personality traits, even though a percentage of the latter type have sufficient actual ability.

Just what the physiological nature of intelligence is, no one has been able to answer. Suffice it to say that it is undoubtedly an undiscovered function of the nervous system. The size and weight of human brains vary little. Within the range of moderately bright, moderately dull, and average people there are no discernible differences. Only the most

depraved idiots have small or ill-formed brains. In fact, some have huge brains, a congenital disease called hydrocephalus. The brains of the most famous people average a trifle larger than general averages. Yet that of the brilliant writer, Anatole France, was 10 per cent smaller than that of the average man. Women rate as high as men in intelligence tests, but they have brains smaller than those of men in the same proportion as their bodies are smaller. But lack of knowledge concerning neural causes of different abilities need not discourage us. We know much about the nature, the measurement, and the workings of intelligence, and this is sufficient for practical purposes.

3. Constancy of Intelligence

Perhaps the fundamental point underlying the measurement and practical application of tests is that *intelligence level remains fairly constant throughout life*. This principle has some exceptions. It holds true especially during the growing years, while in school, but less so during adult life. The decline may be of score only, not of intelligence itself, and may be produced by "mental rustiness." See page 377 for amplification of this. This fact is linked with innateness, since one criterion of an innate trait is that it does not change, except with great difficulty, with experience or with the passage of time. If you are born with brown eyes, they will remain brown all your life. If you were born with high intelligence, you will remain intelligent until the time of senile decay.

This concept has immense practical value in educational and vocational guidance. Within a small margin of error, by the time a child is six years of age we can tell whether he can be graduated from college or whether his top limit will be grade school or high school education. Similarly, we can tell whether his efforts should be aimed at a laboring occupation, at one on the white-collar level, or whether he may make a success of law or medicine.

Under normal circumstances environment exerts comparatively little effect. In later chapters we shall see that certain forces, such as adoption into a superior family, do influence the intelligence quotient. But for most of us the environment remains about the same, since we spend our early and adolescent years in the same home situation. As a specific example, a boy may not only be the son of a storekeeper, but he is brought up in the class of home a storekeeper can provide, and the father's income tends to remain the same during the years of childhood and adolescence.

The problem of constancy of intelligence can be approached statistically by comparing scores made by children on several successive tests

given at one- or two-year intervals. If scores remain constant, we know that the intelligence has not changed. Many such studies have been conducted, and the results show surprising steadiness. Naturally, the score cannot be expected to be exactly the same on each test, but successive scores do remain within a few points and certainly within the general range. The subnormal person remains within his group, the average person does not become either dull or bright, and the bright person stays well above average.

Let us quote a few such cases:

(1) Girl, tested five times between $6\frac{1}{2}$ and $12\frac{2}{3}$ years. [19] Scores were: 105, 95, 107, 101, 103. Here we see that the extreme variation is twelve points, with no score more than seven points away from the average. There is no material difference to be derived from interpreting any of the five figures. We would predict that this girl would do about average high school work, but would probably do poorly in college, if she could get along at all.

(2) Girl tested nine times between $2\frac{1}{4}$ and 10 years, IQ's of 155, 146, 142, 142, 138, 138, 146, 143. [5] Ignoring the first test, which was administered at such an early age that its results are uncertain, the total range is only ten points. She is superior in every testing; in fact, in every test she shows herself to be in the top 1 per cent of the population. Pintner comments on this case: "This amount of variation over a seven-year period is relatively small. Such a series of IQ's is called constant. A fluctuating series would show IQ's jumping around from 140 to 100, back to 145 and then down to 90 and so on." We might compare this with temperature fluctuations. If temperatures of 80, 83, and 76 were recorded for three days, we would say that the weather had remained the same. If it hopped from 80 to 105, then down to 40, we would say that it was highly uncertain.

(3) Case of boy just out of the moron level, tested four times between $8\frac{1}{2}$ and $12\frac{1}{3}$, IQ's being 71, 72, 73, 72. These last scores, in fact, are unusually stable.

In another study nearly five hundred children were tested after one to four years' interval. [5] More than 85 per cent of the cases fell within eight points of their original scores. The variations tended to occur more often in the group tested four years later than with those tested at closer intervals, but not to any marked extent. In a study of more than a hundred children with IQ's above 130, 82 per cent still remained within the top 1 per cent after ten years and none of the others fell to the average of 100. [7] Terman analyzed a number of cases in which a child was bright in early grades but fell off later. In practically every case there was a serious disturbing factor, such as

epilepsy or incipient mental disease. Correlations between scores on successive testings usually run over $+.80$. [15]

One person who disbelieved in the constancy of the IQ went to a great deal of trouble digging up from school records cases of large shift. When he proclaimed that he had discovered twelve cases showing shifts of as much as thirty points, he was asked how many cases he had consulted and was forced to admit that they had been selected from a list of five thousand!

4. Generality of Intelligence

Is a person equally bright, or equally dull, in all mental functions? If he has an IQ of 110, will he possess that level of ability in mathematics, languages, history, and in his vocation? Would it be more exact to speak of a number of intelligences, rather than just one?

We often hear students say that they are not very good in mathematics, but that languages and history present no trouble. Since we cannot accept such private evaluations as conclusive, it is of immense practical value to ascertain the truth of such claims.

Before we plunge into our discussion let us say that we are interested at this point only in "intelligence" as the psychologist defines it. This limits intelligence largely to reasoning and verbal facility and does not include cleverness in handling people, common sense in driving an automobile, or talent in art or music. These are abilities of a different nature, and will be discussed in the next chapter.

There are three chief theories as to the relationships among intellectual abilities:

(1) The first is that it is all-round, or *general ability*. Spearman, an English psychologist and statistician, is the leading exponent of this view. [14] This theory holds that each person has a certain degree of ability to use in disposing of any given task. A student should earn roughly the same grades in each course he takes. If he does not (and we know full well that he does not), the discrepancy may be accounted for, not by differences in ability, but by effort expended, previous training in that subject, or likes and dislikes.

Spearman allows for some unevenness among abilities, however. Any given task not only demands general ability, but it has in addition certain specific demands. Ability in any function, say mathematics, is composed of a person's general aptitude, which can be applied to any subject, plus his specific mathematical aptitude. Research has shown that general ability overshadows special aptitudes. Applying this principle practically, then, it may be legitimate in some cases for a student to be below his own average in some subjects, and also to excel in

others. Differences in true ability should not account for more than one letter grade discrepancy among all school subjects. Differences larger than this, and many of this size, are usually emotional in origin and not representative of genuine intellectual level, as will be illustrated by a few cases at the end of this section.

(2) *Group factor theory*. Several authorities have felt that aptitudes occur in groups and are not bound up in a single unitary ability. For example, one might be good at various types of mathematics, fair at various modern languages, but poor in literary subjects. Thurstone [18] and Kelley [8] have contributed especially to this idea. Thurstone has employed complex statistical operations and claims to have isolated seven primary mental abilities: visual imagery, perceptual speed, memory, word fluency, number facility, induction, and verbal relations. Kelley mentions verbal, numerical, spatial, and mnemonic (memory) factors, a list which corresponds more closely to our conception of the processes.

Although these factors are claimed to be primary and unrelated to each other, most tasks ordinarily encountered demand use of several of them. Since there nearly always is such overlapping, the advocates of this theory do not deny some generality of intelligence regardless of the reason for its existence.

(3) *Multiple factor theory*. Still other investigators argue that each capacity is unique and separate. If this theory were carried to its logical conclusion, we would have to say that ability for one subject would not only fail to predict performance in a similar subject, but that any given person actually possesses different levels of ability within a single field. For example, we would not speak of language ability, nor of ability to learn French, but we would have to subdivide that subject into learning French vocabulary, French grammar, French sentence structure, and so on.

Actually, however, the adherents of this theory do not practice what they preach. Thorndike [17] has long been associated with such a belief, but one of his mental tests is called the "CAVD" scale, the letters standing for four functions: completion, arithmetic, vocabulary, and following directions. He also speaks of verbal, mechanical, and social intelligences. Within each of these three fields aptitudes are correlated, but between one and another (say social and mechanical) there is no relationship. In both cases, however, he seems to assume group functions.

SUMMARY

The truth concerning generality of intelligence is difficult to discover. Experiments do not agree, and objective results may be given different interpretations. However, dozens of experiments and complex statistical analyses suggest that the truth lies somewhere between the general and the group factor theories.

Mental abilities appear to be fairly constant. A child with an IQ of 120 will be better in all his school subjects than one of 80; there are practically no exceptions. Even in college, where all students are of a high degree of ability, we find consistent differences. Those on probation rarely get higher than C grades in subjects with which they do not have difficulty; those who make an average of B or better almost never have serious trouble with any course. Cases in which a student makes good grades in general, but fails language or science or mathematics, occur rarely and may be accounted for by lack of interest or any other reason apart from native aptitude. Here are several actual cases.

J. does pretty well in science and languages, but he has failed English twice. He comes from a family of Polish immigrants, Polish is still spoken in the home, and he himself, although born in this country, has traces of an accent. His lack of English handicaps him not only in that subject, but also in expressing himself properly in Economics and Sociology.

E. has always wanted to be a journalist, and makes A grades in that department and in other courses that demand writing, but gets D's and E's in many others. Simply a matter of lack of interest. Perhaps he should not go to a state university but should find some school where he can take courses only in his specialty.

H. took a strange aversion to Chemistry, cutting class practically every day, and proving stubbornly resistant to the professor's suggestions. He claimed that the latter "had it in for him." Careful investigation disclosed that the instructor's beard reminded him (unconsciously) of his father, who also wore the same facial adornment, and who domineered him very thoroughly. The dislike and resentment against his father came out in symbolic form, directed against a man who somewhat resembled the father and who also stood in a position of authority over him.

In the last two cases emotional matters interfered with success—from dislike to actual antagonism. In the first case the family background militated against good work. In no case was innate ability a feature.

We may conclude therefore that intelligence is a fairly general function and that we have about the same ability to apply to any given

task. Although differences are slight, we might as well take advantage of even slight superiorities. In college we major in the subject in which we do best and are most interested. In business we give ourselves the best possible advantage for success by capitalizing on the ability which stands out a little above the rest. If denied a chance in our chosen field, there is comfort in the knowledge that we can do virtually as well in others.

III. SPECIAL ABILITIES

Intelligence tests, we have previously pointed out, are designed to measure abstract or verbal abilities, but the reader should not think of intelligence as the only indication of his potentialities. Its importance cannot be denied, but there are many situations in which other capacities are more necessary. In general, an intelligence score gives a better prediction of academic achievement than of any other type of accomplishment, although vocational levels can be predicted to some extent. Certain other abilities, such as proficiency in mechanical, aesthetic, and social lines, are correlated either not at all or else poorly with general intelligence.

1. Social and Personality Traits

Intelligence is only one aspect of personality. For example, intelligence contributes only a portion to one's economic success. Success in many occupations—insurance salesman, hotel clerk, or public relations counselor—depends much more upon personal and social attributes than upon ability to solve abstract problems. Promotion in military or police service is often based more upon bravery and persistence than upon understanding of military science or principles of crime detection. In two police departments, tests showed that the officers were less intelligent than the patrolmen and the stenographers who took orders from them.

2. Mechanical Skills

Mechanical intelligence refers to facility in handling tools and machinery, and is possessed by mechanics, dentists, watch repairmen, and musicians. Some splendid mechanics can barely read and write. And some brilliant men do not have the mechanical skill to change a tire if they have a blowout.

Motor skills are not correlated with abstract intelligence. The brighter person is not likely to be more expert in typing, dancing, or playing

golf, but his speed of learning a new act may be more rapid. One boxing champion cannot read or sign his name to his checks, and another claims to read Shakespeare for pleasure. One big league baseball player is a college graduate with Phi Beta Kappa distinction; others are laborers before and after their athletic prime. However, football and basketball coaches report that the brighter boys learn plays faster and understand instructions better.

3. Physical Traits

Investigators have sought to relate behavior to one physical trait or another, but with little positive success. There is no correlation between height, weight, or a height-weight ratio and intelligence. There are no consistent differences in IQ among children who are normal, underweight, and overweight. This may seem to contradict the statement that gifted children are taller and heavier than average children and that subnormals are often smaller. These trends are true of groups, but not for each person as an individual. Scholars may be short or tall, light or heavy, of varying complexion. Napoleon was five feet two inches in height, Lincoln six feet four inches.

We have shown that intelligence cannot be estimated from facial appearance, except in cases of serious deficiency. The "beautiful but dumb" proverb is an obvious fallacy. Indeed, an attractive appearance may be positively correlated with high intelligence, owing possibly to greater mobility of the features or to better food and care.

4. Aesthetic Abilities

Skills in aesthetic pursuits, such as art, music, and poetry, are distinctly special abilities, with virtually no relationship to general intelligence. Proficiency in these fields cannot be predicted from an individual's aptitude score. In some instances persons in the dull normal level have produced creditable work. Very bright people may not be able to sing on pitch or to draw a recognizable picture. In one case a group of superior children (IQ above 135) was tested on a battery of music tests and fell into an average distribution. In college, some honor students would fail in the schools of music or art, and some in those schools would have trouble with the more abstract and verbal courses. These discrepancies do not, however, suggest a negative relationship. At the lowest the correlation will not fall below zero. The law of individual differences which states that desirable abilities are to a greater or lesser extent positively correlated applies to aesthetic abilities.

When we consider the more complex and creative aspects of aesthetics, we must admit the presence of a high order of intelligence. No one questions the mental superiority of Beethoven, Wagner, Paderewski, Leonardo da Vinci, and Milton. To conceive, plan, and execute a great work of art is evidence of abstract as well as aesthetic ability. These trends were seen in a study of school children. Although scores on musical aptitude tests correlated only $+ .20$ with intelligence, those children who showed exceptional musical ability ranked well above the average of all children in intelligence.

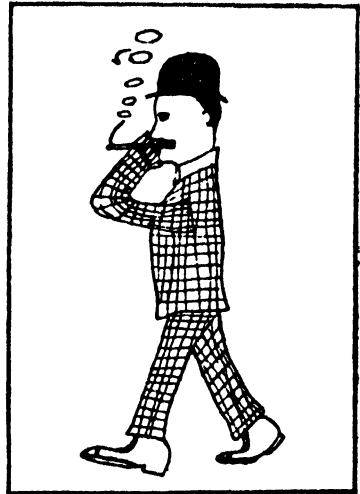

FIG. 38.—Children's Drawings of a Man.

Intelligence is measured from these drawings of a man, not so much from the artistic qualities as from the thought processes indicated by the parts included and the relations shown. The simpler drawing was done by a much younger child and receives proportionately more credit for his age than the other.

Drawings have been utilized by Goodenough in a unique intelligence test. [6] The child is asked to draw a man, and he is rated according to the number of items included and the appropriateness of relationships, rather than solely upon his skill in drawing. Artistic standards are completely disregarded.

Points are given for presence of arms, legs, trunk, for the trunk being longer than wide, for distinct shoulders being apparent, for eyes, nose, lips, nostrils, hair, knee joint, arms reaching about to hip, ears in correct position and proportion, and other similar points, also clothing present, clothing not being transparent, no incongruities (not part military and part civilian clothing, for example). Scores on this test

have been standardized for various ages. A preschool child is considered normal in intelligence if he shows a head, with eyes as circles, nose and mouth suggested by single lines, and feet emerging directly beneath the head without any trunk. Older children are expected to add to and improve upon the picture in details and proportions.

We give two actual drawings as samples. Fig. 38A was drawn by a girl of four years ten months; her score is thirteen points, equivalent to a mental age of six years three months, or an IQ of 129. Fig. 38B was done by a boy of eleven years two months; he earned 47 points, but at this age his development is not so great as the girl's for her age, and his IQ is 116. You will notice that neither drawing shows artistic skill, but each contains many elements in proper relationships.

This test correlates surprisingly well with general intelligence, Goodenough quoting a coefficient of $+0.76$ with Binet score. This correlation occurs because the aesthetic element is ignored and acuteness of observation and appreciation of the relations, such as proper location of the shoulders, is emphasized.

5. Idiots Savants

Persons of low general ability occasionally have an extraordinary talent along one line: mechanical, graphic, musical, arithmetical, a keen memory for details.

A famous case of this sort was the "Genius of Earlswood Asylum," who was deaf, lacked education, and probably would test in the imbecile class. His true rating would probably have been higher, but because of his deafness and lack of opportunities he developed "isolation amentia," a mental disturbance induced by separation from ordinary social intercourse. He did possess remarkable skill in drawing and carpentry. His most famous production was a ship model, about ten feet long, which contained thousands of small nails and screws and a full set of sails and ropes. Three years were spent in completing this model.

An uneducated Negro with a mental age of about eight (his abilities were so irregularly developed that his mental age as measured by tests ranged from 4 to 12) was reported to have phenomenal memorizing ability. [2] When a questioner said, "I was married on the 8th of June, 1901," the Negro replied without the slightest hesitation, "Dat was Satu'day." He knew the day of the week for every date between 1901 and 1924, but none outside those limits. He kept a record of all trains, engine numbers, and stations along the line. He consulted this constantly, and could repeat lists of railroad statistics. The normal individual undoubtedly could learn this material in a fraction of the

time, but he does not bother. I know two men who can recite practically the entire passenger schedule of all railroads in the United States, the numbers of the trains, schedule changes, allowances for daylight saving; yet they manage all this as a spare-time hobby.

A few years ago a semi-tramp, undoubtedly of the idiot savant class, appeared from time to time at various universities, and picked up small change by answering all sorts of questions about American history. He had quite a reputation for infallibility and wide knowledge. Since the students knew only a moderate amount of history, they could not ask him many complex questions. But one day an instructor happened to come by, asked several questions which departed from routine facts, and in a few minutes had the supposed expert hopelessly tangled up.

Lightning calculators constitute another group. Only average or even subnormal otherwise, they may be able to compute complicated problems with extraordinary rapidity. An illiterate Negro slave was asked how many seconds a man who was seventy years, seventeen days, and twelve hours old had lived. He gave the answer of 2,310,500,800 seconds in a minute and a half. One of the questioners attempted to verify the calculation by pencil and paper, and thought he had detected an error, but the Negro immediately pointed out that the other had neglected to allow for leap years! Other idiot savants are able to multiply four place numbers and give to several decimal places the square root of a large number. But such superiority usually lies in the more mechanical operations. They are unable to do problems involving higher mathematics. If they possess this latter ability, they may be considered truly intellectual.

Others of this class show remarkable routine memory, often without comprehension of the material. They can quote long speeches in a foreign language or sing without error every song heard during a show. One man paid no attention to the meaning of a sermon or play but spent his time counting the words spoken. [9]

By way of generalization, it seems that idiot savants have attained their remarkable skills in the following ways: (1) Intensive practice in one field to the neglect in others; (2) a person who is uneducated or underprivileged may be potentially bright, but has been able to develop himself only in one field; (3) often routine rather than complex mental operations have been highly developed; (4) the ability may be more superficial and spectacular than profound or genuine; (5) an extraordinarily high degree of ability unaccompanied by ability in other lines does not occur in verbal activities; (6) in some cases, true aptitude does exist unaccompanied by equal proficiency in any other field.

6. Performance Tests

Many people suffer from language handicaps of some nature: recent immigration, illiteracy, origin in backward communities, deafness. Such limitations make the standard verbal tests unfair to these particular individuals; hence psychologists have devised performance tests in which the subject *does* something instead of saying or writing something.

The Army Beta is one of the best known. It is a companion to the Alpha test, but designed for foreigners who do not read and write English and for illiterates. It was so cleverly designed that it could be given without spoken directions, from diagrams on blackboards and gestures with pointers. One traces his way through a maze with a pencil, counts the number of cubes pictured in a pile, completes this series: x o o x o o x o o —————, substitutes symbols for numbers as in a code test, draws in missing items in a picture such as an eye in a face, a trigger in a pistol, and strings in a violin. These tests supposedly measure thought processes without demanding language, but there is some question whether they actually do so beyond a rather low mental age. They are probably of greatest service with preschool children who have not as yet learned to read and write.

Other performance tests demand motor skills. We have already discussed the Gesell norms to estimate the rate of development from the age of acquisition of certain motor abilities (Chapter III). The Pintner-Paterson test measures a simple order of constructive ability. It includes a "Manikin Test" in which the subject places together six wooden pieces, representing the head, the body, the two arms and the two legs of a man, and also a "Feature Profile Test" in which eight pieces are to be put together to make a human face. These, with the other tests making up the scale, correlate about $+ .50$ with mental age. [4]

7. Achievement and Educational Tests

Although intelligence tests measure an innate ability, they must operate to some extent through what has been learned. Consequently, they include only procedures or items of information which all children of a given age have had an equal opportunity to learn. At the opposite extreme, final examinations in school subjects test the amount each pupil has learned. Achievement tests are a third type: they indicate a pupil's educational status, either in general or in an individual subject. For instance, an achievement test in arithmetic would measure a student's ability to handle fundamental processes and operations,

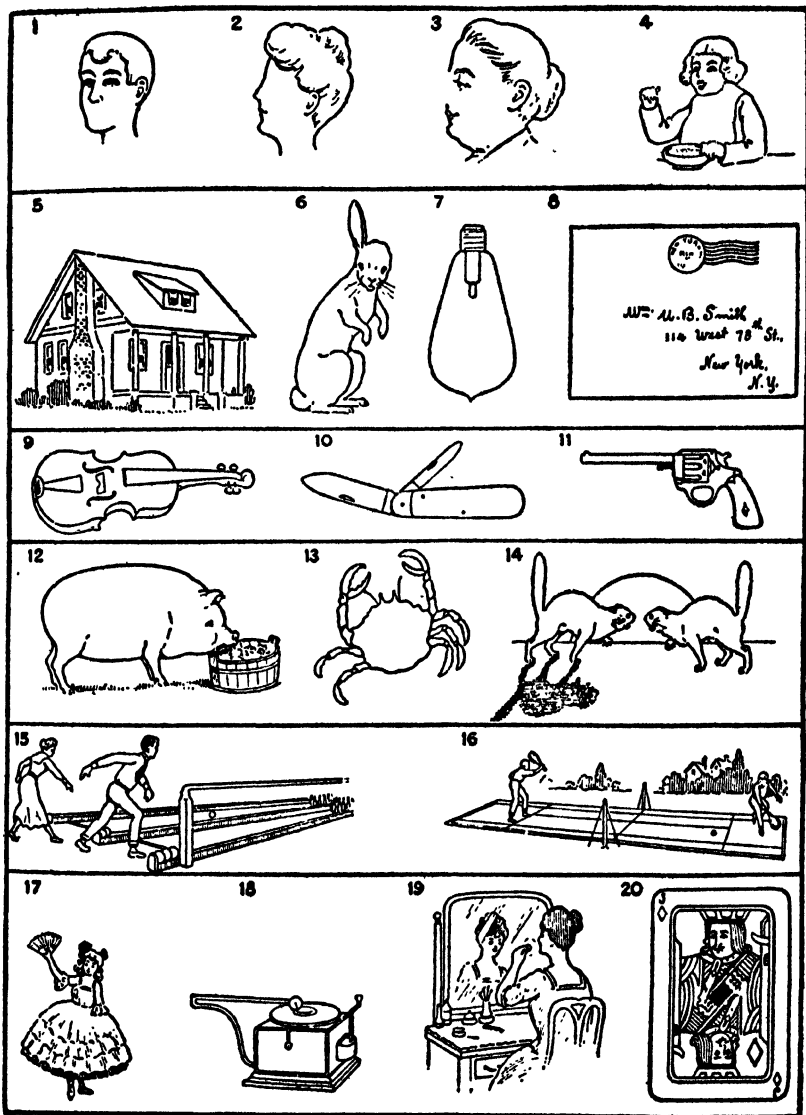

FIG. 39.—Army Beta Test.

Fill in the missing element from each of these pictures. (From Army Beta examination.)

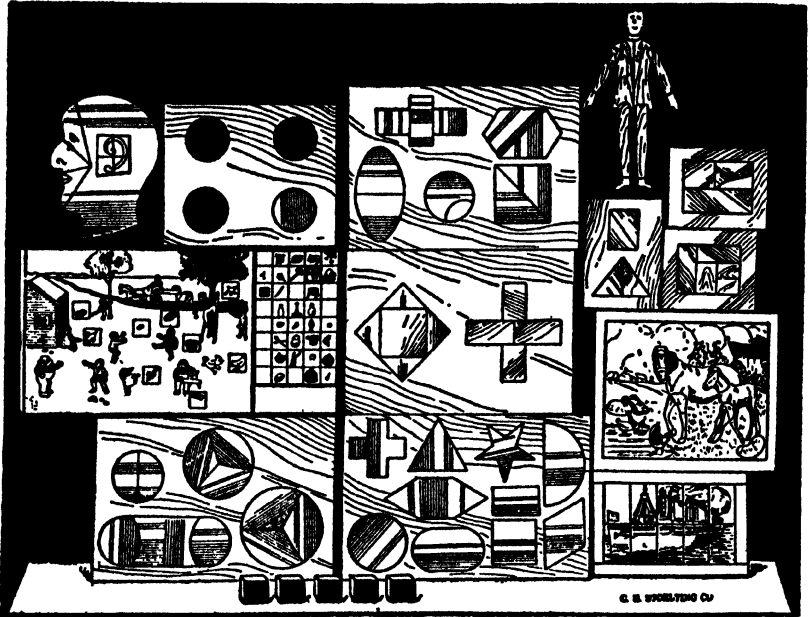

FIG. 40A.—Completion Tests.

The various parts are presented to the subject in pieces and are to be put together. (Devised by Pintner and Paterson.)

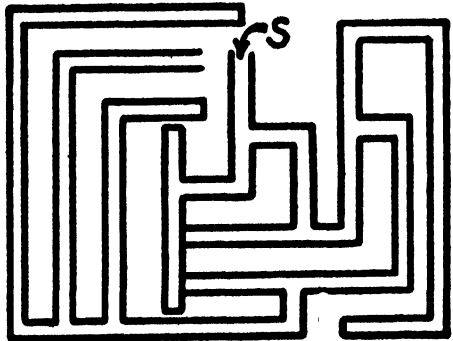

FIG. 40B.—Maze Test.

The tracing from start (S) to goal (the open alley) is timed.

rather than to solve problems upon which the class has been drilled. In foreign languages, sight reading exams take the place of tests on assigned books. Tests of achievement are valuable in placing a pupil in the proper grade when he changes from one school to another. They also assist in diagnosing advancement or retardation in each subject.

In some subjects students' ratings may be closely correlated with their intelligence scores, while in others there may be little correlation. For example, reading is closely related to abstract ability. Bright chil-

dren sometimes read when they are three years of age, although in other fields they are not sufficiently developed to warrant beginning schoolwork. Specific disabilities may result in poor correlation; occasionally an average or even a bright child is handicapped. These handicaps occur in left-handed children and in those with defects of vision, audition, and emotional instability. Some of these defects make it difficult to measure the intelligence, since reading is fundamental to most tests. Dull children often master the mechanics of reading, but they are weak in comprehension of the material.

Occasionally a person who is normal in everything else has difficulty with mathematics. This is usually more emotional than intellectual. Because we often read our lessons hastily and hope the facts will stick in our memories, we are distressed by the necessity of careful and accurate work. When the emotional element is eliminated, tests prove that mathematical thinking is closely related to, and no more difficult than, other types of reasoning.

Other subjects that are weakly correlated with general intelligence are spelling, drawing, penmanship, music, shopwork, and deportment.

8. Common Sense

Is judgment in practical situations related to abstract or verbal intelligence? No categorical answer can be given, and since there has been little experimentation on this subject it is approached with some hesitation. Several intelligence tests have included so-called common-sense questions, such as "What would you do if you were playing baseball and it started to rain?" or "What should you do if you accidentally bumped into a lady and knocked her over while dancing?" But, as we saw with social intelligence, what a person answers and what he actually does in such situations may be quite different.

Many instances of supposed stupidity are based upon lack of experience. A city girl caused much laughter when she admitted that she thought radishes grew on trees. A country boy appeared at a disadvantage because he thought the netting in a Pullman berth was a hammock. A college graduate may be abused by a laborer for his ignorance, because "You have had your nose in a book for years and you don't know the fish and game laws of the State of California." A garage mechanic thinks a lawyer is "dumb" because he has trouble changing a tire or adjusting a carburetor.

Impulsiveness in word or action—failure to think a matter over before speaking or acting—may incorrectly suggest stupidity. A woman at the seashore stopped another stroller and asked, "Do you know what the altitude is here?" A brilliant college professor burned his car when

he lit a match to look into the gasoline tank. Both these people knew better, but they acted without exercising the function of self-criticism. Absent-mindedness might be placed in the same category. A person, immersed in deep thought about something else, leaves for the theater without his tickets, forgets where he parked his car or left his hat, or goes to work in his bedroom slippers. Such behavior appears to be as characteristic of bright as of dull people. (See Freud's explanation p. 265.)

SUMMARY

Intelligence tests are devised to test true or native ability. These tests chiefly use novel situations and knowledge which everyone has had an equal chance to acquire, and it is expected that the brighter person has acquired more. Information acquired under special circumstances not available to everyone is avoided.

Tests for children are devised according to age levels. When a child's mental age has been determined, his Intelligence Quotient may be obtained by dividing that figure by his chronological age. The IQ is an index of the relative rate of mental growth. The mental age concept is rarely used with adults; percentile standings compare each with others of his own group. IQ or percentile status remains relatively constant throughout life, a fact which suggests strongly that intelligence is largely innate.

Important characteristics of intelligent people are that they profit from experience, vary their responses to fit particular situations, discern distant relationships, carry on abstract thinking, delay action, and criticize their own efforts.

Intelligence is a general ability, that is, a certain level of mental ability which can be applied to almost any intellectual task. Where performances of considerably different quality appear, the discrepancy is largely due to interest, motivation, background, previous training, and other influences wholly apart from genuine abstract ability.

To avoid creating the impression that abstract intelligence covers the whole range of human abilities, we mentioned several non-intellectual, or special, abilities. Some which are more or less distinct from general intelligence are: personality and social traits; mechanical, athletic, and physical aptitudes; and aesthetic abilities. Performance and achievement tests are fairly well correlated with general intelligence, but they approach the measurement of ability from somewhat different angles. Common sense is probably fairly well related to abstract intelligence, but lack of experience, impulsiveness, and absent-mindedness may produce apparent discrepancies.

REFERENCES

The sample items from adult intelligence tests were selected from the following: Henmon-Nelson Test of Mental Ability, Army Alpha, Thorndike Intelligence Examination, American Council Psychological Examination, Teachers College Psychological Examination.

1. Anastasi, A. *Differential psychology*. New York: The Macmillan Co., 1937. Chapter X.
2. Byrd, H. A case of phenomenal memorizing by a feebleminded Negro. *J. appl. Psychol.*, 1920, 4, 202-206.
3. Freeman, F. S. *Individual differences*. New York: Henry Holt & Co., 1934. Chapter IX.
4. Garrett, H. E., & Schneck, M. R. *Psychological tests, methods, and results*. New York: Harper & Bros., 1933. Part Two, Chapter II.
5. Garrison, S. C. Additional retests by means of the Stanford Revision of the Binet Simon tests. *J. educ. Psychol.*, 1922, 13, 307-312.
6. Goodenough, F. L. *Measurement of intelligence by drawings*. Yonkers, N. Y.: World Book Co., 1926.
7. Hollingworth, L. S., & Kaunitz, R. M. The centile status of gifted children at maturity. *J. genet. Psychol.*, 1934, 45, 106-120.
8. Kelley, T. L. *Crossroads in the mind of man*. Stanford University, Calif.: Stanford Univ. Press, 1928.
9. Mitchell, F. D. Mathematical prodigies. *Amer. J. Psychol.*, 1907, 18, 61-143.
10. Nemzek, C. L. The constancy of the I.Q. *Psychol. Bull.*, 1933, 30, 143-168.
11. Peterson, J. *Early conceptions and tests of intelligence*. Yonkers, N. Y.: World Book Co., 1925.
12. Pintner, R. *Intelligence testing*. New York: Henry Holt & Co., 1931. P. 87.
13. Pintner, R., & Paterson, D. G. *A scale of performance tests*. New York: D. Appleton-Century Co., 1917.
14. Spearman, C. *The abilities of man*. New York: The Macmillan Co., 1927.
15. Terman, L. M. *The intelligence of school children*. Boston: Houghton Mifflin Co., 1919.
16. Terman, L. M., & Merrill, M. A. *Measuring Intelligence*. Boston: Houghton Mifflin Co., 1937.
17. Thorndike, E. L. *The measurement of intelligence*. New York: Teachers College, Columbia University, 1926.
18. Thurstone, L. L. A new conception of intelligence. *Educ. Rec.*, 1936, 17, 441-450.
19. Woodworth, R. S. *Psychology*. (3rd ed.) New York: Henry Holt & Co., 1934. P. 62.

XVI

EDUCATIONAL AND VOCATIONAL GUIDANCE

Here we shall discuss the educational possibilities of human beings at various levels of intelligence. How far can a "dull normal" go in school? How much farther can an "average" boy progress? What occupations are appropriate for each?

1. Educational Guidance

In the United States education is offered free of charge to all boys and girls through grade school, high school, and in some localities through a municipal or state university. In fact, children are required to go to school until they reach the age of fourteen, sixteen, or eighteen, depending upon state law. The value of free education has been widely recognized, but with this recognition there has developed a popular assumption that any person can absorb as much education as he desires. Hence parents are sometimes resentful when an educator suggests that a pupil of limited ability be withdrawn from school.

But it is obvious that not everyone can profit from higher education. No one would think of sending a feeble-minded person to college. Neither education nor the favorable environment of a university would raise his intelligence sufficiently. What about a person with an IQ of 80, 90, or barely 100?

The usual age for school entrance is six. Normal progress brings a child to high school at fourteen and to college at eighteen, although many prospective college students skip a grade. Assuming that public school work fits the average child, we could say that one should have a mental age of six to start school, of fourteen to continue into high school, and of eighteen (superior adult) to handle college courses. In actual practice the figures are reduced slightly; otherwise the lower half

of each class would fail. However, approximate limits of educability of various classes of intelligence may be derived.

TABLE 22
EDUCABILITY OF VARIOUS LEVELS OF INTELLIGENCE

Idiot	Maximum mental age of	4	No schooling
Imbecile	"	8	2-3 grades
Moron	"	11	6-8 grades
Dull normal	"	14	A little high school
Average (IQ 90- 99)	"	16	High school
(IQ 100-109)	"	17	Perhaps college
Superior	"	20	Complete college, and many can take professional training

A person who is slightly retarded should be kept behind others of his age. For example, a boy with IQ of 70 cannot do first-grade work when he is six years old, since his mental age is only 4.2. But he should be able to do it when he is eight.

When a retarded student is allowed to work with his superiors, he usually fails and becomes discouraged. If he is passed, because of sympathy or superior effort, he eventually runs into grief in school or in work. This is especially true if he gets a job on the basis of a school record which makes him appear brighter than he really is. Furthermore, a person of low ability acts as a drag on the progress of his class in school. Since the brighter pupils have to go at a pace slower than they could maintain, they derive less benefit from instruction.

A case of going beyond educability on the part of a person of mediocre ability is cited. A woman went to school 13 years, but by educational tests it was found that she had only the knowledge possessed by the average person who has done 6th or 7th grade work. It is evident from this that the mere fact of having done high school work does not by any means guarantee having what we consider a high school level of ability. Tests showed that she actually had a higher degree of mechanical ability than verbal. She had taught public school, but was very unsuccessful, going from one position to another, and finally was unable to get any work of that character. She later worked as a freight clerk in a small town at a very low salary. Recently she was totally unemployed. From her general and special ability tests, it is apparent that she should be in domestic or factory work; white-collar work seems out of her class. Her education and attempts to teach were costly mistakes. [5]¹

Pupils tend to be passed along from one grade to another as much because they have put in the time as because they have demonstrated

¹Paterson, D. G. The Minnesota unemployment project. *Person. J.*, 1932, 10, 318-328.

mastery of the material. Rarely is a student retarded more than a year or two; yet a certain number are always several years mentally behind the average of their class. At the other end of the scale, very bright children may just keep pace with their age group or only a year ahead; yet under a more flexible system they could be accelerated by several mental years.

Terman [6] found that first-grade children had mental ages all the way from three to ten, in the following proportions:

3 years mentally,	2 per cent
4	15
5	21
6	34
7	22
8	4
9	1
10	1

And in the first year of high school:

12 years mentally,	2 per cent
13	7
14	23
15	23
16	22
17	13
18	8
19	2

Yet all were attending the same classes, doing the same assignments, reading the same texts, and supposedly acquiring the same education.

Another important discrepancy is noted when intelligence levels in various schools and colleges are compared. Usually rural schools have pupils of slightly lower ability than city schools. The same intelligence test given to students in more than two hundred colleges revealed these facts: private schools are usually ahead of state schools, northern universities are higher than southern, Negro colleges are lower than white. Several small colleges surpass the largest universities, but not as a general rule. The quality of student body is regulated by policies of admission and curricular standards.

Recently there has been a growing recognition of the fact that some people are limited intellectually. In several large cities the lower grades are subdivided into advanced, average, and "opportunity" (subnormal) sections. The pace of learning is adapted to pupils of these three broad ability classifications.

In high schools there is usually a choice of three curricula: college preparatory, general, and vocational training. Boys and girls with the

greatest academic aptitude are urged to take the college course and to enter a university if they can. The second group takes intellectual courses, often with foreign languages and the more abstract subjects omitted. The vocational course avoids highly verbal subjects and stresses typing, shorthand, bookkeeping, and manual training. It has been suggested that persons with IQ's under 95 should be permitted to take only the vocational course. Those over 110 should plan to go to college, and those between 95 and 110 may do so if they are conscientious students. It should be said that these figures are only approximate, since college standards differ so widely that a person who fails at one might earn honor grades at another. Our figures are based upon the requirements of most state universities.

Quite often the situation takes care of itself, since many of the brighter boys and girls usually desire to go to college and the duller ones are not so anxious. In one high school it was found that those who registered for the college preparatory course averaged seven points higher in IQ than those who took the general course. Unfortunately, however, many young people overestimate their abilities, and that is one reason why educational guidance is important.

A final source of discrepancy between ability and performance hardly needs to be mentioned. A student of 130 IQ can fail in college if he does not work, and one with barely 100 can graduate if he applies himself effectively, although the latter probably could not make Phi Beta Kappa. In actual experience it has been found that few people earn higher grades than their aptitude scores predict but many fall below expectation. Hence we are fairly safe in establishing a person's upper limit and in suggesting that he not try to go beyond that.

2. College Success and Intelligence

Hundreds of studies have been conducted on the relationships between school grades and intelligence. The trends of the *levels* seem to be as follows: $+.60$ between grade school performance and intelligence score, $+.50$ between high school record and aptitude, and $+.40$ between college average and test score. Two chief reasons account for the lesser agreement in the higher educational levels. First, the range is narrower. The poorer students have fallen by the wayside. Within this narrow range of abilities, slight differences in aptitude and effort count for more than they would if the spread were wider. Second, effort is probably much more uniform in grade school than above that level. High school homework is more variable than supervised study in the grades, and in college there is a high degree of freedom in both study and classwork.

Here is a chart showing the relationship between intelligence and grades in a private eastern college. Since the college has a superior student body, all the students may be assumed to have an IQ of at least 110. Yet it is evident that students who received relatively lower scores in the test fared badly and that success in studies mounted with intelligence scores. Virtually all the honor students were in the top fifth of the distribution. Of those in the lowest fifth only a quarter were able to maintain a C average.

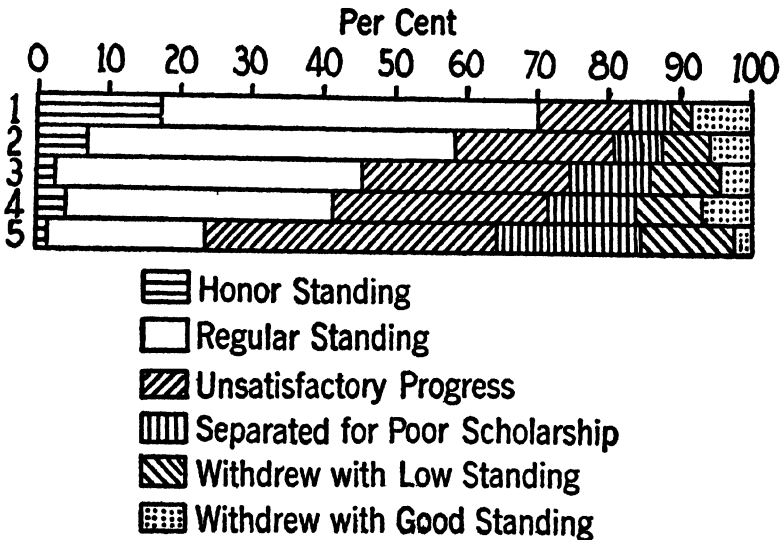

FIG. 41.—Relation between Aptitude Scores and College Grades. [3]

The top fifth contains many honor students and very few who failed; each fifth lower down shows a less favorable picture.

At several universities formulae have been devised to predict probable scholastic achievement. Factors with the greatest predictive value are intelligence and high school average. Combined, they predict with greater accuracy than can each alone. Each of the two factors has about the same weight, it has been determined by objective statistical procedures. This suggests an important argument. Does it not speak well for the accuracy of intelligence tests that in one hour we can obtain a measure which foretells college grades as accurately as four years of high school work, totaling possibly 2,500 hours? In the main, students fall into place about where we expect them. Freshmen for whom failure is predicted seldom graduate in the usual four years. Those for whom there is a high prediction usually earn A's and B's.

Not every case, by any means, is predicted accurately. Some reasons for inaccuracies of prediction are: health, necessity for excessive outside work, difficulty of curriculum (engineering is harder than agriculture, for example), quality of high school preparation, environment (students in a fraternity usually do less well than those living in less social surroundings), participation in outside activities such as athletics, publications, theater, music clubs, love affairs, and personal qualities such as ambition, ability to work regularly, thoroughness, open-mindedness, and so on. As to these last points, any formula utilizing high school achievement must assume that the student will put forth the same effort in college. Usually this does occur, but if a person's study habits change materially for better or for worse, there is bound to be a discrepancy between predicted and earned grades.

When such a discrepancy occurs, we usually make a case analysis. When there is a wide discrepancy between expected and obtained grades, we can almost always find an adequate reason for it. Professors and administrative officials make practical use of the intelligence score and the grade point prediction in helping the student to solve his problems. If he is low on his test score or his prediction, it may be best to advise him not to go on with college, or to suggest a transfer to a school with less rigid standards. Another alternative is to advise a reduced program, especially if the student must do outside work for partial or complete self-support. Only the best students should tackle a full program if outside employment amounts to more than two or three hours a day. Decisions concerning graduate work in an academic subject or in a professional school may be aided. If the student is doing poor work, but has a high IQ, we should look for some distraction or source of inefficiency. In individual courses, the instructor is often able to discover whether a student is working to capacity. Another use of predicted averages is in disciplinary cases. The dean may be uncertain whether a student who has done poor work should be given another chance or dismissed. If the student has low aptitude there is little expectation of improvement; so he should not be encouraged to continue in higher learning. On the other hand, if high grades are to be expected, the student may be helped in planning his work so that he may more nearly approach his true level of performance.

3. Vocational Selection

Vocational guidance cannot be separated from educational advice, since a person's occupation is partly dependent upon how far he goes in school and what courses he can assimilate. If a person is advised not to go to college because he does not have sufficient abstract ability,

he is automatically eliminated from the professions and certain other vocations. If a high school student is advised to take the college preparatory course, it is assumed that he will enter an occupation which requires abstract ability.

Intelligence is one important feature of vocational selection. It is obvious that a person cannot do a task for which he has not the aptitude. A moron or a dull normal should not be expected to become a surgeon, a lawyer, or even a good office worker. It would likewise be a waste of potential ability for a boy with IQ of 130 to become a common laborer.

However, let us emphasize the statement that intelligence is not the only qualification necessary for professional success. Personality traits, especially those concerned with getting along with people, are in most occupations more important than intellectual capacity. Some of the employees of a large concern may rate higher in an intelligence test than the president, but he usually makes up for that lack by other qualities. We do not mean to suggest that socially acceptable but exceedingly stupid persons often rise to positions of responsibility. This is the crux of the matter. If we grant that each vocation requires a minimum degree of ability, then we must admit that a person cannot be successful in a certain job unless he possesses the requisite amount. However, if he has more, it often does him little good in that particular business. As a concrete example, a man might need to possess an IQ of 100 to become a successful automobile salesman, but he would be no better, as salesman, if he had a rating of 110 or 120. Below 100, he might not be able to understand his product sufficiently, but the fact that he does understand it is all that is necessary. Beyond this point personality is the important factor for promotion to a higher position (sales manager, for instance), an additional degree of intelligence is necessary.

Another relationship between intelligence and vocational choice is demonstrated by statistics on turnover. At the time of employment, scores cover a rather wide range. But as time goes on, men near both extremes disappear from the pay roll. Those who are below average for that type of work tend to quit or be discharged. Since those above average find the work unstimulating, monotonous, or lacking in opportunity for advancement, they leave to find work more suited to their capacities. Since time is wasted by such hit-or-miss methods of employment, many industrial concerns are using intelligence tests.

The various IQ levels may be listed in terms of the vocational possibilities of each, just as they were listed in connection with educational guidance.

TABLE 23

APPROXIMATE IQ'S NECESSARY FOR VARIOUS OCCUPATIONS

Idiot	No employment possibilities; cannot even care for himself.
Imbecile	No gainful employment; may assist a little about the home in crude laboring tasks.
Moron	Routine and crude manual labor. Many tramps and casual workers who drift from one job to another belong in this group. Doubtful if many in this group could earn enough or take on sufficient responsibility to justify marriage.
70 - 89	Mechanics, clerks in small store, office work of simpler nature, taxi drivers, barbers.
90 -109	White-collar class, clerical work, skilled mechanics, stenographers, small businessmen.
110 -120	Public school teachers, doctors, lawyers, businessmen with larger organizations.
120+	Highest professions, scholars, inventors, and famous people of various sorts.

It should be pointed out that these figures are only approximate, hence open to minor modification. For example, a man might be a good enough country doctor with an IQ of 110, but most eminent surgeons and specialists have a higher degree of intellectual capacity. Many of the presidents of the United States have earned Phi Beta Kappa honors in college, and the number of senators, governors, and nationally known businessmen who have shown eminence at an early age is very impressive.

In order to give proper vocational guidance, many occupations need to be subdivided. For instance, no single figure can be quoted for salesmen, since it is necessary to know what type of article he is expected to handle. Table 24 shows the intelligence scores of salesmen dealing with different classes of goods. (These figures are not IQ's; they are gross scores on a test.)

TABLE 24

SCORES OF SALESMEN HANDLING DIFFERENT TYPES OF GOODS [4]

Type of goods	Number	Average	Range
1. Low grade; make change on one-priced article.....	52	51	36- 70
2. Wholesale order takers.....	73	89	59-121
3. Insurance salesmen.....	326	112	82-138
4. Selling technical articles requiring training.....	66	139	124-155

There is a great deal of difference between working in a five-and-ten-cent store and selling complicated technical articles such as printing presses and factory machinery. There are individual differences in Table 24, however; each group contains cases well above and well below

its average. However, if we compare Group 1 with Group 3, or 2 with 4, we see that there is no overlapping at all in the ranges. For success in selling, a person needs sufficient intelligence to understand the article; beyond that point differences in personality traits determine mediocre, good, or outstanding success.

Likewise, a high school teacher should have a better score than a teacher in grade school. A college teacher should be still higher, because he deals with students of greater intelligence and maturity. This is not the whole story, however. Many college teachers could not teach first grade satisfactorily, since they do not have the patience or ability to handle young children.

Finally, several studies concern college grades and later business success. Although these did not utilize intelligence tests, marks can be assumed to involve both ability and effort. The first study was made by one of the largest industrial concerns in the country, the Bell Telephone System, on 3,806 college graduates of various ages, who had worked with the company at least half the time since graduation. [1] The chart below shows the relationship between position in class at time of

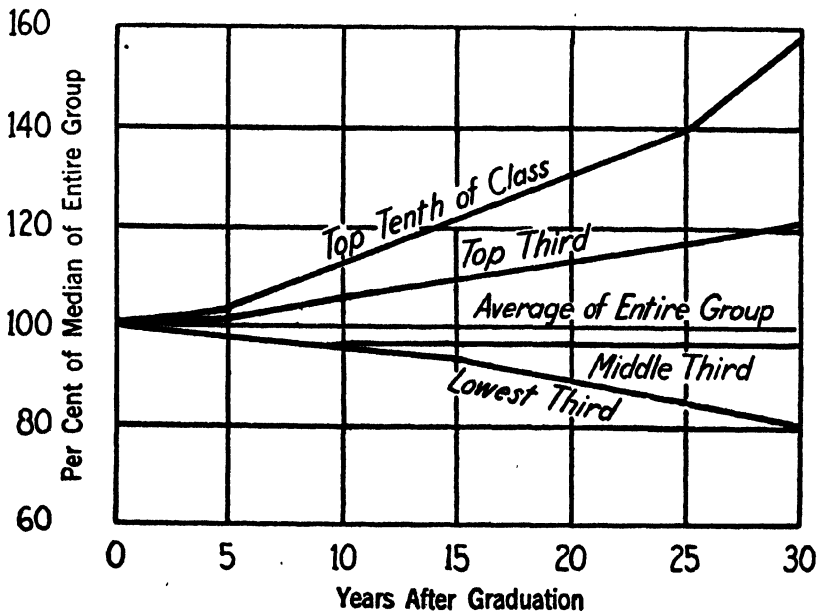

FIG. 42.—College Grades and Subsequent Salaries.

Incomes for various years after graduation on the part of men who stood in different positions in their class. Scholarship, or the qualities which go to produce it, is shown to be very important.

graduation and the earnings at different ages. The trends demonstrate conclusively that the careless student who rationalizes that college grades are irrelevant is wrong. Some students turn over a new leaf when they start to work, but in most cases slovenly habits continue.

Other indices are of decidedly minor character. Those who engaged in outside activities did slightly better than those who had not participated, but the index is only 120, as compared with 160 for high scholarship. The most predictive activities were editorial, debating, and managerial work. Athletes in minor sports fared as well as those in major sports. Earning one's way through school (often claimed to be a character builder) insured no subsequent benefits, except for those who got high grades along with their work.

Similar results have recently been published in connection with a survey of the present status of a class which graduated from Harvard in 1911. The Phi Beta Kappa men were well ahead of the next nearest group. Those prominent in social activities were second, perhaps because of the personality element. The average men were third, and the athletes last. [7]

These findings may be interpreted in two ways: either the college training was responsible or high intelligence permitted the attainment of good college grades and subsequent occupational eminence. The correctness of the latter interpretation was suggested by a study which compared the early vocational careers of college graduates and those of non-college graduates of equal intelligence scores. [2] Their salaries were equal, although the college graduates held more of the socially desirable positions. (Many well-educated people are ministers, social workers, or teachers, occupations for which pay is disproportionate to the abilities and training demanded.) This study was done on young people, however, and its results cannot be accepted as final until people for whom we have school and intelligence records become middle-aged. In another two decades we shall know much more about the relationship of intelligence to occupational success.

RECOMMENDATIONS

Studies we have quoted indicate that there are minimum and maximum levels of mental ability for success in any occupation, and also that there are minimum levels for successful attainment of any given educational level.

Therefore, we recommend that an individual should not plan his education and vocation until his mental ability has been ascertained. A good filing clerk is far more useful to society than a mediocre or poor

accountant. An individual who reaches the limit of his mental and mechanical abilities in becoming a laboratory technician should not, for his own sake, try to become a surgeon. Correspondingly, a person capable of becoming a research chemist should not content himself with being a pharmacist's assistant. All occupations are respectable and socially useful, and the laurels in each go to the most proficient; that is, to the one who has chosen most wisely in terms of his own aptitudes and interests.

REFERENCES

1. Bridgman, D. S. Success in college and business. *Person. J.*, 1930, 9, 1-19.
2. Dvorak, B. J. A preliminary study of the economic value of college training. *Bull. Employ. Stabil. Res.*, Institute of Univ. of Minn., 1934, 3, 9-14.
3. Husband, R. W., Sr. Studies in student personnel at Dartmouth College. *J. Person. Res.*, 1923, 2, 70-79.
4. Miner, J. B. Standardizing tests for vocational guidance. *Sch. and Soc.*, 1921, 13, 629-633.
5. Paterson, D. G. The Minnesota Unemployment Project. *Person. J.*, 1932, 10, 318-328.
6. Terman, L. M. Intelligence of school children. Boston: Houghton Mifflin Co., 1919.
7. Tunis, J. R. Was college worth while? New York: Harcourt, Brace & Co., 1936.

XVII

GROUP DIFFERENCES

I. EXCEPTIONAL INTELLIGENCE: FEEBLEMINDEDNESS AND SUPERIORITY

1. General Observations

In this section we shall consider the characteristics of people at the two extremes of the distribution curve. Are there vast differences between people with IQ's of 70 and 140? Do their minds work differently, or is the better one merely faster?

Under ordinary conditions only extreme differences can be detected. No difference in appearance is discernible unless a person is in the imbecile or idiot class. A genius cannot be differentiated from an average person on first sight. A person may have casual contacts with a moron or dull normal for months, yet never suspect that he is mentally below par. Only when the observer knows an individual for a long time or sees him face an intellectual situation can he point out differences in mental acumen with any degree of accuracy.

The validity of the observational method was proved when a psychology class was divided into discussion groups in accordance with intelligence scores (the students were not informed of the basis of division). The higher scoring groups not only earned the highest grades on examinations, but their classwork was more impressive: they were eager to learn, asked many questions, argued with each other, and displayed a real understanding of the subject. The poorer groups appeared lifeless; they asked few questions spontaneously, rarely became involved in arguments, and hesitated to answer direct questions from the instructor. The brighter students were interested in theory, the mediocre ones only in practical or concrete examples. Yet all were

college students; the lowest classes had IQ's averaging over 100, and the highest probably averaged no more than 120. If you met those same students at a dance, there would be no observable differences.

2. Rates of Growth

Figure 43 shows that persons of different mental levels develop at different rates. Brighter people not only reach a higher ultimate mental age, but they are accelerated all along. Dull people are retarded from the beginning, fall farther behind each year, and arrive at their maximum at an early age. An idiot may quit growing mentally when he is six, while a genius may still be gaining at eighteen or twenty. We remember that the average person arrives at his maximum mental development at sixteen.

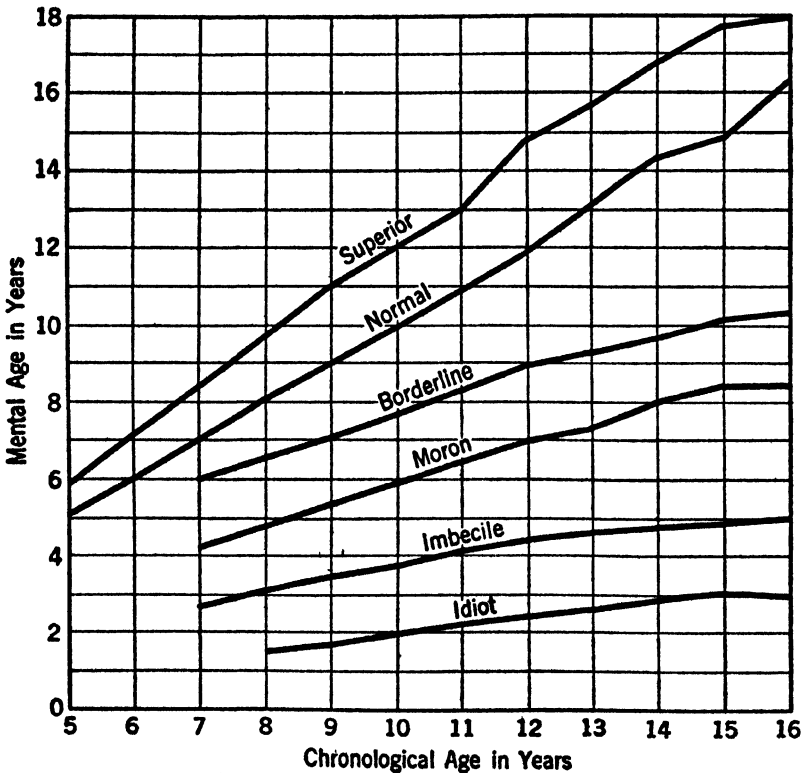

FIG. 43.—Curves of Growth for Persons of Different Mental Levels.

Intellectual growth of children of different mental abilities. Not only does the dull person develop less rapidly all along, but his ultimate peak is reached earlier. (From Pressey, p. 211.)

3. Feeble-mindedness

(A) LEVELS. Dr. E. A. Doll, director of the Vineland, N. J., Training School (for backward children), has given very clear descriptions of the three levels of deficiency, in terms of what the children can and cannot do. [7]

The idiot is a person who cannot protect himself from ordinary dangers, who cannot provide for his ordinary wants, who has practically no speech, and who needs throughout his entire life that kind of personal assistance which is commonly given to children under 3 years of age. . . . He is personally helpless and socially useless, a burden rather than a menace, requiring attendance in nearly all his wants and making little significant response to training outside the field of self-help.

Likewise the imbecile, while able to protect himself from simple dangers, provide for his ordinary wants, feed and dress himself, and exercise a fair degree of speech, is incapable of performing any but the simplest occupational tasks, of acquiring any appreciable degree of literacy, or of getting along socially without continued supervision. . . . The imbecile, in contrast with the idiot, compared rather favorably with young children except that he lacks their capacity for original adaptation, their natural vivacity, their spontaneous inquisitiveness.

The moron, on the other hand, while capable of performing all the social achievements of the idiot and the imbecile, goes beyond these by acquiring a low degree of literacy, by learning occupational pursuits at the common labor, factory-operative, or apprentice level of employment, and by getting along socially with only occasional supervision. The moron, however, is not capable of getting along "on his own" socially with more than marginal success, or of providing for others, or of exercising good judgment in social adaptation. . . . It is this social incompetence of the moron that distinguishes him from the dull-normal more specifically than his other qualities. . . . The most obvious defects in the moron are his absence of good judgment, his naïve personality, his unstable social morale, his weak inhibitions, and his low capacity for sustained effort under stress.¹

(B) BEHAVIOR DESCRIPTION. The idiot and the imbecile may be dismissed after brief consideration, since they have little practical place in society and fortunately are few in number. Let us cite one typical case. [18]

F.Q. is the offspring of a feeble-minded mother and a dull-average father. He first walked at the age of three and has never learned to say more than a dozen words meaningfully. He imitates the sounds heard in sentences, but without appropriate significance. He can feed himself, using

¹Doll, E. A. Idiot, imbecile, and moron. *J. appl. Psychol.*, 1936, 20, 427-437.

a spoon, and has at length learned to dress himself if the clothes are given to him one at a time. He does not persist in any activity without continued stimulus and specific help. He cries when he is hungry and he knows where the food is kept, although he has never learned how to get it for himself. This child is an idiot, IQ 25-30. Children like him seldom enter school.²

To compare abilities of grossly deficient with those of monkeys, Harlow and Israel [11] tested idiots and low-grade imbeciles, with mental ages chiefly between one and three, on the delayed reaction tests described on page 34. Candy mints were used for reward after each correct choice. The human beings learned the principle of upturning the cup under which food was placed a little more readily than did the monkeys (not anthropoids which are superior to monkeys), but they were not able to achieve any longer delays. Also, in the more complex delay problems there was a practical equality. So far as could be estimated, the mental capacity of the monkeys was on a par with human idiots of a two-year mental age. This estimate cannot be taken as final, however, since the test score of an individual so abysmally deficient cannot be absolutely precise.

In contrast, the moron is a marginal member of society capable of dealing with some situations but ineffective in others. Let us therefore see in more detail just what a moron's mental processes are. An illuminating description is contained in a fascinating book by Eleanor R. Wembridge, *Life among the Lowbrows*. In the book she describes many experiences with retarded and maladjusted unfortunates encountered in her social work. [27]

Chuck and Flora, mental ages about twelve and eleven, got married in spite of protests from those who knew what troubles such a union inevitably would face. We quote:

Ultimately, therefore, Flora must budget Chuck's twenty dollars a week to cover rent, food, clothes, movies, gas, tobacco, lipstick, chewing-gum, and layette. To do this required addition, subtraction, and even multiplication, and these processes must be accurate and rapid enough to count the change before the peddler walked away with the extra dollar.

Her conversation was about as follows: If Chuck remarked, "There goes a white horse," she shouted with laughter, and said, "Hot dog!" If he said, "That's a Ford," she agreed, murmuring, "You said it," and snuggled closer. She could also say, "Ain't it so?" "You're a fright," "I'll say," "Hell's bells," and "You're crazy with the heat." She could, moreover, giggle and say nothing, which worked quite as well. She was healthy and good natured, she liked company, and was normal in all but mind.

Could Flora expect to be a match to the agents who called at her door?

²Miles, C. C. Intelligence and social adjustment. *Ment. Hyg.*, 1938, 22, 544-566.

"Start a home library with 'Flames of Fervor,' urged one. "Greatest deeds done and who done 'em—for less than a cent a page." Flora was dazzled—less than a cent a page for so much print! She made a five-dollar installment payment, and had nothing left to pay on the grocer's weekly bill, for she had paid a like amount toward a fur coat, the same on the rent, and Chuck had retained five dollars for his own use. Four times five makes twenty—surely not difficult for a normal mind. But a moron cannot grasp its significance rapidly enough to come to a decision before the agent has disappeared around the block.

You recall, no doubt, the standard example in arithmetic which every fourteen-year-old schoolchild is supposed to be able to solve: If two pencils cost five cents, how many can you get for fifty cents? Not only pencils, but doughnuts, dill-pickles, apples, and cotton handkerchiefs are bought at about this price. But neither Flora nor any of her moron friends could master the problem. We knew they could not because we had asked them. Flora's answer was twenty-five because two into fifty is twenty-five. Her friend Lucille's, on the other hand, was a hundred, because two times fifty is a hundred. (Lucille's husband is in the penitentiary for stealing motorcars—he had to steal something to keep ahead of her shopping.) Another friend, Annie, ventured a still more generous estimate. She said: "Five times fifty, because five cents times fifty cents is five times fifty—whatever that is." Chuck himself answered ten, because, "You get two for five, and two times five is ten." It will be observed that all of them knew that something must be done in the way of arithmetic, and that their arithmetic was generally correct—except for the fact that they could not select the right process to employ. A simple problem was to them as Relativity is to the rest of us. If our household accounts depended upon a real understanding of Relativity, we should be precisely in Flora's case, for her capacity to live within her income depends upon simple arithmetical analysis. If she and her friends had been low-grade feeble-minded, they could not even have multiplied their twos and fives. But they were only morons.

It was certainly essential that Flora, out of Chuck's weekly twenty dollars, should save a little for the future, so another example suitable for a fourteen-year-old was set for her. "If you have twenty dollars a week, and spend fourteen a week, how long will it take you to save three hundred dollars?" Flora, who had a sense of humor, could not at first get past the joke that she should ever save anything. "A lifetime," she answered—"and a long lifetime." Then, "Three hundred times fourteen." "Three hundred times fourteen what?" we persisted, and Flora answered "dollars." The example was written out for her, but she had completely lost the connection, and when she was again reminded, "But how long a time would it take to save it?" she answered, as if through the telephone, "2025." What she meant by that we shall never know. We know only that the firms equipped to solicit business with the mentally unsound will find Flora out and use the

courts to collect their bills. We know also that with such arithmetical equipment her savings account will never be large.

Flora's good nature had often led her into difficulties, not only with agents in the way of rash purchases, but with friends in the way of picking up joy rides, calling out of the windows to people she did not know, wearing ultra-conspicuous dress when she and Lucille (whom she soon took as a boarder) went shopping, and overindulgence in matinees which neither could afford, and in which her flirtations with the trombonist made Chuck very jealous. Lucille, as a temporary widow (her husband in prison at the time for stealing motorcars), felt that she had a right to flirt with whom she chose, and Flora, from long habit, followed her example.⁸

The author then asks, "In what words shall one urge the laws of morals and good taste upon a moron of flaming cheeks and healthy appetites, whose inclinations are those of an adult body with a child's mind?" Persons whose mental capacity precludes more than a few years of schooling, who can't add up their weekly expenditures, and who answer the question, "What is justice?" by "Peace; I got married by one," cannot understand abstract discussions of moral principles. Threats of social disgrace mean little, since most of their friends are sexually promiscuous, and since few of them can resist a trinket in a store or an automobile with keys in its lock. In fact, among certain circles a headline and a picture in the paper is worth a month behind bars. When such types emerge from jail they enjoy a brief glory among their friends. At worst, it is felt that they were unlucky or inept.

Therefore, we can state that low mentality is an indirect cause of delinquency. The earning power of morons is limited, yet they are most inclined to imitate the dress and manners of movie heroes and heroines and society idlers. They wish to emulate these people and their more affluent, and brighter, friends. They want to do their hair the same way, wear the same clothes and fur coats, and go to roadhouses in cars. How is a girl to get a fur coat? How is a young man to transport his girl to the dance hall?

To make such people walk "the straight and narrow," authority must be substituted for reason. Religious authority is one type that is usually respected. The more formal religions which give orders of divine origin are more successful in inculcating restraint than are those that recommend modes of conduct based upon social ethics. Wembridge points out the merits of the Victorian era, when standards of conduct were not a matter of reason and judgment but of fiat. These

⁸Wembridge, E. R. *Life among the lowbrows*. Boston: Houghton Mifflin Co., 1931, pp. 4f.

standards have been characterized by contemporary writers as conventional, prudish, hypocritical, but if they lead to socially desirable conduct they may be justified. It is sometimes possible to appeal to these people through their worship of movie heroes and society people: a movie hero does not shoplift or steal cars, a famous actress does not allow herself to be picked up by strangers, society people do not enjoy being in jail.

Let us conclude with one more brief quotation:

Ann and Lizzie determined to tell nothing of their past; this turned out to be from no fear of revealing anything incriminating, but because questioning meant a brain test. A brain test meant that we would fly at their heads with a surgical saw. Ann confessed that she had always disliked operations, and hated to have her skull cut open. Lizzie was fearless as to injury to her brain, but was determined to save her permanent.⁴

Such is an intelligence test to a moron!

(C) VARIETIES OF DEFICIENCY. Dull people are no more alike in their abilities and disabilities than those of average intelligence. Ignoring for the moment the purely quantitative aspects of deficiency, there are variations in accompanying behavior. One writer expresses it thus, after studying 252 cases with a mental age of eight years: [17]

Some were conscientious and relatively trustworthy; others were most untruthful, dishonest and unmoral. In some, sex proclivities seemed to be the dominant interest, while in others the sex interest seemed to be entirely normal.⁵

In general we have concerned ourselves with *amentia*, which means literally "absence of mind." This is distinguished from *dementia*, where there has been loss of mental power as a result of accident, brain injury, disease, glandular disorder, old age, or insanity.

Retardation is not exactly equal in all functions. Quite often children who have IQ's near the boundary of feeble-mindedness are found to be better in spelling, penmanship, and shopwork than they are in subjects more abstract and less routine in character. This inequality in retardation suggests that the procedure in elementary schools of promoting or failing a grade is faulty. A boy or girl may be ahead of his class in spelling and behind in mathematics or reading. In larger schools it should be possible to follow the college system, where a student may be taking advanced, intermediate, and elementary courses simultaneously. Reading *comprehension* must be considered; frequently feeble-minded

⁴*Ibid.*, p. 299.

⁵Louittit, C. M. *Clinical psychology*. New York: Harper and Bros., 1936, p. 251. See especially Chaps. IV-VI.

persons attain a good degree of mechanical reading ability, but they do not understand what they have read.

(D) VOCATIONAL POSSIBILITIES OF FEEBLEMINDED. We have already seen that idiots and imbeciles have virtually no economic possibilities; so our discussion will be confined to those with IQ's between 50 and 70. One study did show, however, that 5 per cent of individuals with IQ's below 40 had at one time or another been gainfully employed.

A thorough study was made of the economic status of adults who had been rated as feeble-minded while in school. [3] The investigator followed up 126 males and 80 females, with average IQ's of 60, and compared them with a control group of people with IQ's around 100. Of the 107 males alive at the time of the investigation, only 12 had been steadily employed for a solid year, and 18 others had held jobs for periods of between six months and one year. The great majority did crude labor, worked on farms, and did "odd jobs." Almost all the women who worked were engaged in housekeeping, for themselves or as domestics. Slightly less than a quarter of the subnormal men could be classed as self-supporting, in contrast to 86 per cent of the control males and 83 per cent of the subnormals contributed to their support to some extent; this demonstrated that there was no total depravity or complete inability to perform constructive work. Since they were marginal employees, dismissed among the first and hampered in obtaining new employment, three times as many were on relief. This subsequent history, gathered more than ten years after tests had been administered, supports in an indirect way the hypothesis of the constancy of the IQ.

There is a borderline between the completely self-supporting and the totally dependent among mental defectives. Just as a child can contribute to the running of a home by mowing lawns and washing dishes, so can an adult with a child's mentality be of partial economic and social utility. Men can work on farms and serve as casual laborers and women can act as domestics. But they will need guidance in various ways: patient and lengthy instruction as to their duties, regulation in financial expenditures and in the purchase of clothes, moral safeguards. In the early stages of training they are often "farmed out" for the day and returned to the institution at night.

4. Superiority

By way of contrast, let us study the abilities and accomplishments of people who have a high degree of superiority. We shall do this in two ways: by studying people who have been successful, and by tracing the characteristics and subsequent development of children who make high intelligence scores.

(A) CHILDHOOD OF FAMOUS PEOPLE. In line with our emphasis upon the constancy of the IQ and the differential rate of growth of people of various abilities, we might expect exceptional adults to have been precocious as children. This is true.

It appears that in many instances mental superiority, like mental deficiency, is early manifested and is continuous. It appears also that this superiority manifests itself in better and earlier motor control (as in manipulation, walking, drawing, and copying), in keener perception of the environment (as in exercise of curiosity, in attentiveness), and in the ability to employ language and numbers.[9]⁶

Although it is impossible to give an intelligence test to a deceased person or to test as a child one who is now middle-aged, we can often form a reasonably accurate estimate. If we can find letters an adult wrote at certain ages, we can tell by a study of sentence structure and vocabulary the approximate mental age of the individual, and thus in effect subject him to an intelligence test. This technique was used by Catherine Cox in an interesting treatise entitled *The Early Mental Traits of Three Hundred Geniuses*. She selected men who had become famous in various fields, omitting persons who had become known through accident of birth (kings, for example) or by destructive enterprise. [6]

The average estimated intelligence for the entire group was between 135 and 145. Remember that these people were chosen for their historical eminence, not for purely intellectual qualities. The latter were estimated long afterward. The group as a whole showed a range from just above 100 to almost 200. In general, the historical figures below the genius criterion of 140 were soldiers, artists, and musicians—activities demanding abilities other than abstract verbal manipulation.

People of only moderate ability occasionally occupy a place in history if they are men of action rather than of thought. Famous generals and explorers average 60 or more points below comparatively obscure philosophers and scientists. Thus, Sir Francis Drake and Captain Cook, intrepid explorers, derived fame more through persistence than acumen, hardly rating IQ's of more than 110. Oliver Cromwell and General Ulysses S. Grant were only slightly higher. The latter, according to accounts of their youth, rebelled against formal schooling, cared little for books, and sought more active modes of expression. George Washington, Admiral Nelson, and Garibaldi rate around 125, well into the superior class, but a mark equalled and exceeded by many students in each graduating class of any of our large universities. These men evi-

⁶Freeman, F. S. *Individual differences*. New York: Henry Holt & Co., 1934, p. 232.

denced higher intelligence both by early intellectual interests and by a combination of military pursuits with constructive statesmanship. Lincoln displayed great ability (140) by rising from poor, illiterate surroundings, educating himself, and developing legal and oratorical pre-eminence at an early age.

Persons eminent in aesthetic lines are in a special category. They are not possessed of extraordinarily high IQ's, but they do rate in the upper ranges of the distribution. Rembrandt probably had an IQ of 135 in early manhood; Beethoven, 140; Bach, 140; Van Dyck, 135; Handel, 155. Even though skill in music or art is considered somewhat apart from general intelligence, eminence in these fields requires considerable abstract ability. Composing a symphony comprises performance of a higher order than playing a saxophone in a dance orchestra. (Let us remind you again that an IQ of 130 occurs in only one person out of 100, and 140 in one of 1,000.)

At the top of the list are the writers, poets, and philosophers. Some estimates of IQ's are: Goethe, 200; Coleridge, 165; John Stuart Mill, 170; Milton, 170; Jeremy Bentham, 190; Voltaire, 185; Leibnitz, 190. To be perfectly just, it should be remarked that these men were specialists in fields demanding verbal and abstract ability, so that this method of evaluation was most favorable to them.

Let us give a concrete illustration of extreme superiority by citing a few facts from the early childhood of John Stuart Mill. He seemed literally to have had no childhood, but to have developed rapidly from infancy to intellectual maturity. At three he began to study Greek; at nine he was reading classics in both Latin and Greek. He understood geometry and algebra at eight, philosophy and logic at twelve. At thirteen he began a complete course in political economy with intensive supplementary reading (more than is done by 99 per cent of twenty-year-old college students). He wrote a history of Rome at six and a half, a perfectly spontaneous effort. The analysis of Galton contains such facts as these: he knew capital letters at twelve months and both alphabets at eighteen, he read a book at two and a half, and could sign his name before three. The day before his fifth birthday he wrote this letter to his sister:

I am 4 years old and I can read any English book. I can say all the Latin Substantives and Adjectives and active verbs besides 52 lines of Latin poetry. I can cast up any sum in addition and can multiply by 2, 3, 4, 5, 6, 7, 8, 9, 10, 11. I can also say the pence table. I read French a little and I know the clock.⁷

⁷Cox, C. M. Genetic studies of genius. Vol. II. The early mental traits of three hundred geniuses. Stanford University, Calif.: Stanford Univ. Press, 1926, p. 42.

The 9 and 11 were crossed out, because young Mill realized he had overreached himself a trifle. This self-criticism in itself demonstrates superior intelligence. Again at eight, when away at school, he wrote his father: "I am very glad that you have left off being a banker, for you will have more time to yourself and better health," a filial solicitude which, as Terman points out, fits a mental age of sixteen better than one of eight.

(B) GIFTED CHILDREN. The most famous and comprehensive study of superiority conducted by Terman at Stanford University is still in progress. [25, 26] From California cities Terman and his co-workers selected nearly a thousand school children who had IQ's of 140 and greater. Physical, mental, and personality traits of these children have been studied in most intensive fashion. Terman's intention is to follow these children as they grow up, reach maturity, and take permanent places in the world. The first study was made when they were about twelve to fourteen years of age, and already a second volume has appeared, which traces their progress into college and, in several cases, into vocational participation. It will be of immense value to see what happens to this group when they become forty or fifty, to see whether they will justify their ratings as potential leaders and geniuses.

TABLE 25
OCCUPATIONS OF FATHERS OF GIFTED CHILDREN

	Proportion among Fathers of Gifted Children	Proportion in Population of Los Angeles and San Francisco Census	Per Cent of Quota among Fathers of Gifted Children
Professional	29.1%	2.9%	1003
Public service ...	4.5	3.3	137
Commercial	46.2	36.1	128
Industrial	20.2	57.7	35

(1) *Ancestry.* From what sort of families do these "gifted" children spring? It is quite apparent that they descend from high-quality ancestors. We list below the occupations of the fathers of these children. The quota in the third column should be considered the important figure, since it weights each occupational group in accordance with its magnitude. In this list professional families contribute slightly more than ten times their expected share, and the industrial groups have only a third as many children of superior intelligence as chance probability would dictate.

The more distant ancestry was similarly impressive. Among the

direct and closely related ancestors almost every president of the United States and every member of the Hall of Fame were represented.

(2) *Home environments* of gifted children were also rated and, as might be expected, they were uniformly superior. The parents had greater average education, read more books and quality magazines, received higher incomes. These stimulating factors undoubtedly contribute somewhat to the superiority, although they are of less importance than biological inheritance.

(3) *Physical traits*. Of great interest is the physical constitution of these brilliant boys and girls, especially since popular superstition links mental superiority with physical inferiority. No such thing was found in these cases. The superior children were also superior physically. At any given age they were taller, heavier, and farther advanced. They usually learned to walk and talk earlier, and they even cut their teeth earlier than children with average IQ's. We must note, however, that superiority was more marked in mental than in physical traits. They talked as much as three and a half months early, walked a month early, and cut their first tooth two weeks ahead of norms. They also arrived at the age of puberty somewhat earlier than average children.

Health histories were also favorable. There were fewer cases of headache, malnutrition, weakness, and defective hearing than among school populations at large. They had the usual number of childhood diseases and broken bones. Their average sleep was fifty minutes more than for the control group, but what this means is uncertain—probably more careful parental supervision. There had been more cases of tonsil removal and a larger percentage wore glasses, but this again suggests better medical attention.

Bear in mind that the reverse of these statements is not necessarily true. Large and husky children are not *ipso facto* bright, nor are small people necessarily dull. And all children who walk or talk late are not assumed to be mentally retarded.

(4) *Educational progress*. Eighty-five per cent of gifted children were advanced in school beyond their age level and not one was retarded. However, the acceleration is only 14 per cent, while by definition their intellectual development is at least 40 per cent ahead of average. Their schoolwork is almost uniformly of superior quality. This superiority is most marked in verbal or thought subjects, and is near zero in penmanship, sewing, manual training, and physical activities.

Nearly half of the gifted group learned to read before they went to school, and in many instances mothers said that the children had really taught themselves. Although such reports are often exaggerated, there

is no more reason to suspect mothers of gifted children of embroidering the truth than mothers of average offspring. Spontaneous intellectual interest often characterizes a superior intellect.

We quote two conclusions:

The indications of superior intelligence most often noted were quick understanding, insatiable curiosity, extensive information, retentive memory, early speech, unusual vocabulary.

Although the home environment of the gifted children has been, on the whole, above the average, nothing has been found to warrant the belief that the superior intellectual attainments of our gifted group are in any considerable degree the product of artificial stimulation or forced culture.*

(5) *Interests.* Let us consider what types of activities the very brightest boys and girls prefer, in comparison with average children of similar ages. A most important difference is that the gifted are far more interested in intellectual activities. This applies both to their schoolwork, say literature versus shopwork, and to their outside interests. They liked sports, but they preferred to divide their spare time between games and reading or hobbies; whereas many of the less brilliant boys and girls played from the close of school until dark.

Making collections—stamps, butterflies, rocks—is evidence of outside interests and real spontaneous curiosity. Nearly twice as many gifted as controls had made such collections, and over twice as many had scientific collections.

The greatest differences are in reading interests. Gifted children read more at seven than average children of any age up to fifteen. At eight or nine they read three times as much as average children. The quality of such voluntary reading is likewise superior. They read more science, history, biography, and travel, but less adventure, mystery, and emotional fiction. In other words, they choose books that have more body to them. They also spend more time poring over dictionaries, atlases, and encyclopedias.

A typical case of superiority is quoted here. [18] The interests and general behavior cited may be contrasted with the case of F.Q. cited on page 351.

J.W. is seventeen and is completing his preparatory-school work. He spent two years in a school in Switzerland, where he learned a fair smattering of French and German, so that he can read easily and converse superficially in both these languages. He has made a conchological survey of the

*Terman, L. M. *Genetic studies of genius. Vol. I. Mental and physical traits of a thousand gifted children.* Stanford Univ., Calif.: Stanford Univ. Press, 1925, p. 287.

region in which his vacations have been spent that is rated superior by experts who have seen it. His school work has always been excellent, although he never appears to study, and he has spent much time in reading, research, and discussion. He plays tennis and basket-ball and is a violinist of some talent. His IQ was 155 when he was ten years of age, and there is no indication that his ability has waned.⁹

(6) *Personality* analyses are not so clearly presented as are other traits. However, a few trends may be indicated. The gifted tend to play alone more, are not so mature socially as intellectually, although they are well ahead of their age. They are actually behind the control group in mechanical interests and proficiency. But they are ahead of their age in development of volitional, emotional, and moral traits.

They prefer older playmates, presumably because those of their own age do not interest them. What of the reverse? Will older children take to these younger and smaller, but brighter, boys and girls? From all evidence, it appears that they are readily accepted. At the same time, they are usually handicapped in size, especially for competitive games like football. Child groups are formed on a basis of age more than any other factor.

Several writers have pointed out the possibility of maladjustment among superior children. Their superiority tends to make them impatient of others' inability to grasp things quickly, a trait which in turn may lead to superciliousness. In another direction, their superiority may enable them to grasp school material so readily, often more readily than the teacher herself, that they fall into lazy habits. Then later, in college perhaps, when confronted with a difficult problem, they may give up without a struggle if they cannot solve it in a moment.

Similar findings concerning gifted children were reported in a study by Hildreth [13] which compared the behavior of bright and average Jewish children in a private school. Those with IQ's over 130 were compared with those around 100. The average IQ for the whole school was 115, so that those of 100 might have felt *relatively* inferior. We quote the author's summary.

An outstanding trait of the young gifted child, judged from the results of this study, is the capacity to persevere in the face of difficulty. The gifted child sustains his attention to problems and maintains interest in them even when he recognizes that they contain difficulties insurmountable for him. He remains happy in this situation, not sullen nor recalcitrant. He keeps himself busy by setting tasks for himself, seems to have an inexhaustible supply of mental energy to expend, maintains a pleasant

⁹Miles, C. C. Intelligence and social adjustment. *Ment. Hyg.*, 1938, 22, 544-566.

attitude when difficulties arise, tends to laugh or joke or say, "Well, that's one on me," or he is frank to say, "I guess I can't get that one." The gifted child seldom offers alibis and does not tend to project his failures beyond himself. His mental energy is comparable with an electric filament that glows continuously without exhausting itself. He hungers for problems, asks for more or invents new problems when the supply gives out.

The brighter children included in this study seemed to enjoy a challenging task. They delighted in attempting problems too difficult for them to solve. On the contrary, the child seemed even to dislike doing what he proved well able to do. The brighter group tended to hold the problems in mind better than the control group. The bright children were also more willing than the control group to defer their personal desires until the test was completed. They could hold personal wishes in abeyance and do the disagreeable and see the reasonableness of doing the disagreeable tasks first. It was easier to enlist the interest, to call forth the best effort of the more gifted children. Outstanding traits of the gifted child proved to be superior speed of work, quick responsiveness, and quick comprehension. The gifted children did not so frequently interrupt their work in the midst of an activity to suggest other activities by requests to leave the room or terminate the test.

Quite apart from the test scores themselves, the gifted children at age five tended to show a combination of the following traits in many individual cases: high mental energy, low fatigue threshold, alertness, speed of response, mature speech and language. They exhibited in general playful, gay, humorous attitudes, well-sustained attention, ability to follow directions well, to become absorbed in a task, to maintain a businesslike attitude. They were, on the whole, good-looking children with a good physique. They enjoyed many activities and could describe them accurately. Most of these young gifted children showed little fatigue even at the end of a comparatively long test period. It was often necessary to continue the test through the 10-year level with these five-year-olds, yet attention and interest were maintained on a high level.¹⁰

(C) "THE PROMISE OF YOUTH." Terman's follow-up study conducted about eight years after the original was called "The Promise of Youth." [26] By this time most of the "gifted" were in college and some had graduated. Their educational and intellectual progress seemed to justify in every way the hopes these superior children aroused in investigators and parents.

(1) *Intelligence* scores still remained high. The boys tested as before, but for some curious reason the average IQ of the girls had dropped 17 points. No valid reason could be advanced for the decrease. However, even the girls remained within the top 1 per cent of the

¹⁰Hildreth, G. Characteristics of young gifted children. *J. genet. Psychol.*, 1938, 53, 287-311.

population; so, expressed comparatively, the superiority of the entire group is about as great as it ever was. A few of the boys or girls showed distinct drops in IQ in this study follow-up, although practically none fell below 125. No reason could be assigned for these drops, but it did not occur with sufficient frequency to arouse alarm.

(2) *Educational progress.* These gifted children have been progressing at a steadily accelerating rate. They finished grade school (eight grades) at thirteen years, and high school a little under seventeen, an advancement of more than a year. In achievement tests there was 40 per cent superiority. Virtually all of the group wished to go on to college, and almost all of those who did not go were deterred by financial difficulties. This is important to note, since it shows that educational ambition is well correlated with intelligence. College and high school work had in the main been superior, although there were several cases of failure to work to capacity. As a group they contributed several times their share of Phi Beta Kappa students to graduating classes at Stanford and the University of California.

(3) *Interests.* As in their earlier years, the gifted still preferred intellectual to physical activities. They were interested in sports, but spent only about half as much time in them as did children of average intelligence. Both sexes disliked sewing, cooking, knitting, housework, and such occupations. Does this suggest any prediction about the marital aspirations or attractiveness of exceptionally bright girls? In school the gifted group participated in many outside activities and was likely to gain recognition in any of several kinds of non-academic activity as well as in scholarship.

Vocational plans appeared more settled than were those of a random group of students of a like age. Naturally, many had not decided, but over half had. Four-fifths of the latter group chose the higher professions.

(4) *Personality.* An interesting finding was that gifted boys tended to be less highly masculine and gifted girls less feminine than average girls. This coincides with other studies which have shown that greater intelligence and greater education tend to narrow sex differences in interests and personality traits. In other personality characteristics the group seemed typical enough, except that those with the very highest IQ's, 170-190, tended to have more difficulty in making social adjustments than did those around the 140 mark. But with all, there were fewer differences in personality and social than in intellectual traits.

(5) *Writings,* such as essays and poems, were collected and furnished interesting material. Some written at early ages were truly re-

markable. Such factual evidence demonstrates not only ability, but also spontaneous productive effort.

(6) *Physical* development and health histories follow the earlier results. As the gifted grew up there were few cases of physical inferiority and there was evidence of good health and resistance to disease. This was verified in another study, where the intellectually gifted were found to be 5 per cent taller at nine, and to have maintained this superiority at the age of fifteen. [14]

(D) GUIDANCE OF THE GIFTED. A serious problem arises in connection with handling such superior children. Terman points out that the higher the intelligence the greater is this problem. We noted that intellectual acceleration was far greater than physical and social, even though the latter were present to some extent. Suppose a child has an IQ of 150. He is twelve mentally when his playmates are eight. Should he be in the sixth year of school, in keeping with his mental capacity, or should he be classed with others of his size and social development? Either alternative is partially wrong. We dislike to hold such a child back in school, and he is bored with work that does not challenge his mentality. But if he is advanced he will be cut out from dancing with girls in his class, who are probably inches taller than himself, he cannot compete in sports, and he may be considered an obnoxious kid. If he comes to college at the age of fifteen, which he could easily, he may have difficulty getting along with any social group. A permanent maladjustment may originate. Very careful handling is necessary. I would suggest allowing him to be accelerated not more than a year or two at the most. In large school systems, where there are several parallel grades, it might be possible to occupy the bright pupil's time and enrich his education by giving him longer assignments and additional courses, such as hygiene, citizenship, current events. This will keep him busy and avoid disciplinary problems that sometimes arise when pupils are able to finish their work in a fraction of the allotted time. Such extra work will keep him busy, but will not force him ahead of his social and physical level. Another important factor is that the parents of gifted children also need to be educated. Many bright children have been spoiled by parents who constantly impress the younger person with his superiority over others. By themselves, bright children are not supercilious; if they do things rapidly, they take it for granted, because they have always succeeded at difficult tasks.

II. RACE DIFFERENCES

1. Problems

There are few topics so fascinating as speculation on race differences and possible superiorities and inferiorities. We of the white race, especially those groups living in or descended from Northwestern Europe, like to think of ourselves as the salt of the earth. At the present time we do seem to have the better of it governmentally and materially. These nations have the greatest numbers of automobiles, telephones, tall buildings, and ships. They control four-fifths of the earth, and most of the rest is dominated by the Oriental races, who have been modernizing themselves rapidly by imitating our material culture. Japan has spanned the gap of many centuries in a few decades through its rapid mechanization.

But the situation has not always been thus. Carvings excavated along the Indo-Afghanistan frontier show that seven thousand years ago a high degree of art existed there, at a time when our ancestors were living in caves and using only the crudest tools. Persia, Mesopotamia, and Egypt were once supreme. Where will the centers of learning be two or three thousand years hence?

Even now the white man is not superior in everything. You and I would soon die if we tried to keep up with a central African laborer in the heat and humidity of the jungle, or if we ate and drank the unsterilized fare of the low-caste Hindu. We are far short of the magnificent physique of the Fiji Islander. In art, architecture, and drama we seem not to have come a great distance beyond the ancient Greeks, in spite of study and improvement of materials. Our progress seems to have been predominantly mechanical, especially in manufactured products and the means of transportation and communication.

A problem we have to face at the start is how to define a race. Loosely, we usually think of a race as a group of people, of more or less common ancestry, living in one locality. But no group entirely satisfies these criteria. Russians vary all the way from Orientals to extreme blondes. Germans may be blond or brunette. Jews live all over the world and take on to some extent the characteristics of the nations with which they happen to live. The Swiss are represented by three major races and languages. Americans are a great hodgepodge of peoples living in a country of over three million square miles. Because of the overwhelming complexity of the race problem the best we can do here is to effect a compromise by treating of people who live in one area, and to try to restrict ourselves to common breeds.

2. Intelligence Scores

First, let us give actual scores made on tests by people who originated in various countries. Then we shall argue about the interpretation, meaning, or significance of these scores. We quote in Table 26 the average mental age and the per cent who rated high and low on the Army Alpha test, which was administered to more than a million men in our army during the World War.

TABLE 26
INTELLIGENCE SCORES OF FOREIGN BORN IN AMERICAN ARMY

Country of Birth	Average Mental Age	Per Cent A or B	Per Cent D, D—, E
England	14.87	19.7	8.7
Scotland	14.34	13.0	13.6
Holland	14.32	10.7	9.2
Germany	13.88	8.3	15.0
Native-born whites	13.77	12.1	24.1
Denmark	13.69	5.4	13.7
Canada	13.66	10.5	19.5
Sweden	13.30	4.3	19.4
Norway	12.98	4.1	25.6
Belgium	12.79	0.8	24.0
Ireland	12.32	4.1	39.4
Austria	12.27	3.4	37.5
Turkey	12.02	3.4	42.0
Greece	11.90	2.1	43.6
Russia	11.34	2.7	60.4
Italy	11.01	0.8	63.4
Poland	10.74	0.5	69.9

From this table, and from other investigations which have shown substantially similar trends, we may point out several generalities: (1) Northern Europeans score the highest: British, Scandinavians, and Germans; (2) Southern Europeans—French, Italians, Spanish—are a little lower; (3) those from Slavic and Balkan countries are comparatively low; and (4) immigrants from the eastern end of the Mediterranean are very low. These scores are not entirely consistent, especially in the percentages of superior and inferior individuals, but the general trends are clear enough. Two more conclusions are derived from other studies. (5) Jews and Orientals always score high, and (6) Negroes and American Indians rank very poorly.

Members of the last two groups, Negroes and Indians, score higher if there is white blood present. In fact, the gap between them and whites is lessened in direct proportion to the amount of white blood.

The full-blooded Negroes are lowest, the quarter white next, then the half, and finally those who have only a quarter Negro blood are just slightly under the white average. The same is true of Indians.

Data on the Jews should be valuable, since they are scattered all over Europe. Actually, they vary from high to low in conformity with the country from which they emigrated. Thus, the English Jews are highest, the German Jews only slightly lower, and so on down the line, until we find the Polish Jews testing the lowest of all Jews. In many cases, it should be noted, they score higher than the average of the nation from which they come.

Figures for the first generation in this country have been gathered from many thousands of Wisconsin high school pupils whose parents were born abroad, but who themselves were born and educated in this country. The difference between the highest and lowest groups was much smaller than the figures in Table 27, but the same rank orders appeared in the second as in the first generation. [4]

3. Environmental Influences

I imagine that you have already become suspicious. You may have thought of many reasons why members of one nationality or another might not do well on an intelligence test. Let us point out a few influences which lie outside the scope of genuine native differences.

(A) DIFFERENTIAL SAMPLING. It may be that we get a fine selection from some countries and a lower type from others. It has been argued that people who leave their native country do so because they are not getting along well. They cannot be too bad nowadays, however, for they need enough money for ticket, a character reference, and sufficient financial responsibility to pass rigid immigration requirements. It is just as reasonable to argue that the immigrants are the more alert people who realize that conditions of life are better somewhere else. The Puritan fathers left England to enjoy religious freedom; many excellent citizens left Germany to avoid compulsory military service.

The question cannot be settled by argument or theory. We should ascertain just why peoples of different nations immigrated. Many of them were brought here as manual laborers, to build railroads, to work in steel mills, and so on. Such immigrants would be expected to score lower than those who came to take more intellectual positions. But the children of the immigrants have been largely assimilated. Many Irish came over about 1850 to work on the railroads; now they are politicians and policemen!

(B) LANGUAGE DIFFICULTIES. Immigrants from English-speaking countries have a decided advantage in an intelligence test. This is

especially true when they are compared with recent immigrants who may know the language reasonably well, but not well enough to make a high score on a test with rigid speed limits. Most college students have studied French, or German, or Spanish; imagine yourself taking a speed test in one of these languages. But this factor cannot explain all the differences among the non-English-speaking groups. Why should Scandinavians score higher than Italians? There are more resemblances between the Latin tongues and English than between Scandinavian and our own. Even those who have learned our language well may be under somewhat of a handicap. It was found in Wales that school children who spoke both Welsh and English did poorer than those who used only one tongue. Their vocabulary was less extensive in either language.

(C) **DIFFERENT CUSTOMS.** The rank order in Table 27 corresponds rather closely with similarity of cultures. The British live about as we do; the differences between our customs and those of Germany and Scandinavia are minor. But the differences are greater when we get into Southern Europe, and vast when we compare our own with Slavic, Balkan, and Levantine cultures.

Again, we find exceptions. Why should Orientals score so high? Why are Irish lower than Scandinavians or Germans? Why should Negroes, living in our own country, be so low? In the latter case we cannot claim that they live exactly as we do or have advantages equal to those of whites, but certainly their mode of living resembles ours more closely than do, for example, the customs of the Turks.

In some instances customs have been found to militate against a high score. It is difficult to spur Negro children to go fast and to concentrate for long periods of time. A group of Dakota Indian children could not be made to answer, and it was eventually found that their tribal mores dictated that one should not show off his knowledge in front of others who might know less. [15] Australian aborigines could not be tested satisfactorily, since they could not understand why they should be compelled to figure out the answer individually. They felt that the examiner should reason with them and that group discussion should be allowed. A foreign examiner also arouses suspicion and may thus prevent higher scores.

(D) **ENVIRONMENTAL STIMULATION.** Klineberg [15] made an interesting comparison of the three great races of Central Europe: Nordic, Alpine, and Mediterranean, all of which are represented in Germany, France, and Italy. To the surprise of believers in racial superiorities and inferiorities, he found far greater differences between urban and rural populations than between members of different races

living in similar environments. People living in Paris, Hamburg, and Rome excelled by a number of points all others, regardless of ancestral type or country of residence. To complicate the matter, German Nordics were among the best, while French Nordics were low. Lumping members of the three types together gave these averages:

Nordic	188.5
Alpine	187.5
Mediterranean	185.2
Three cities	215.7

In the United States it has been found that both Negroes and whites living in the North are considerably superior to those of each race in the South. Further, Negroes in the army from Pennsylvania, New York, Illinois, and Ohio ranked above whites from Mississippi, Arkansas, and Georgia. [1] In answer to the argument that perhaps the brighter Negroes migrated north in search of wider opportunities, school grades (in the long run indirect evidence of ability) were checked in the three cities of Nashville, Birmingham, and Charleston. Those who had migrated to the North had grades no more than fractionally different from those who stayed in the South. [15]

Additional evidence that environment is the answer has been furnished by a study of Indians. Those in reservation schools tested from a few to ten points lower than those attending schools in near-by towns. [10] The latter schools are undoubtedly better, and life in general is more stimulating. City life equips the individual better for doing tests where speed is at a premium, since desert or reservation life makes little use of clocks or even of calendars.

The extent and duration of the school year may also be an important factor. In general the United States is ahead of the rest of the world in opportunities and requirements for general education. However, in rural sections of some states the number of days and hours per day are woefully inadequate. Contrast the thirty-six weeks a year demanded by Wisconsin law with a school term extending only from harvest to plowing in certain rural districts. A single rural teacher often has all eight grades, with pupils in most of them. In such cases instruction is so subdivided that one pupil gets no more attention than he would in a two-hour day in a city school.

(E) ENVIRONMENTAL LIMITATIONS. An unfavorable environment can depress intelligence, or at least the *score* on an intelligence test. There is no field in which this is more pertinent than in measured race or nationality differences.

Obviously, not everyone living in the United States is living in the

same environment. In some cases differences arise through social discrimination and in others through choice. The southern Negro is the outstanding example of the first. His schools are poor, he may not have a high school or college, he is forced to live in the poorer parts of town, he is denied many occupations, often he is not allowed in public libraries, and he is denied most cultural opportunities.

Self-imposed limitations are less obvious, but probably nearly as important. Nationality differences are evidenced by the Little Italys, Chinatowns, Harlems, and Germantowns of our big cities. Assimilation is delayed by living in districts with others of the same nationality, reading foreign-language newspapers, and perhaps by sending the first generation of children to schools which use the mother tongue. It is said that people are born and grow to old age in New York's East Side without learning English.

(F) MAKE-UP OF TESTS. Possibly the tests themselves favor English-speaking people. Maybe if a Turk or an Indian were to make up a test by which all peoples were measured, his test might be such that we would find ourselves at the bottom. Translation of tests into another language cannot be done literally, because of differences in shades of meaning, items of common information, social customs, and educational procedures. Actually, if a psychologist wished to turn the Stanford-Binet test into, say, Icelandic, he would have to restandardize each level and each item much in the way we described on page 312. If an African boy living on the equator were asked what to do if the house got cold, his experience would be inadequate to answer it. If he was shown a picture of a man playing golf and asked what he was doing, he would naturally fail. A Kentucky mountain boy, given a question supposedly on arithmetic, "If there were 10 children in a school and 6 of them were out with the measles, how many would there be in school?" answered promptly, "None, because the rest would be afraid of catching it too." Is this right or wrong? Who can say? An item on one test reads: "————— should prevail in churches and libraries." Of course, "silence" is the answer, but Negro children who had attended revival meetings would answer just the opposite. It is said that the Eskimo language contains no number beyond five; therefore an Eskimo could not be expected to do simple arithmetic problems.

The type of test also makes a difference. We have already mentioned the speed factor as a handicap to certain groups. The Negro does almost as well as the white on a performance or non-language test, but he falls down on one involving verbal facility. Jewish children are superior in abstract thinking, but relatively poor in spatial and mechani-

cal functions. Japanese children excel white children in sustained attention, spatial orientation, and visual perception, but fall behind in verbal and arithmetic tests. [2]

A test was especially devised by Oliver [20] to measure the abilities of Bantu children in Kenya Colony, East Africa. The test was non-verbal, consisting of problems dealing with pictures, numbers, letters, and other symbols. The average score was 85 per cent that of European children attending another school in Kenya Colony. Brain weights of natives also averaged 85 per cent as much as those of Europeans, a suggestive similarity to test scores. Oliver points out that these results are especially pertinent, because many American Negroes are of Bantu origin. The retardation in their African homeland is roughly equal to that of American Negroes.

4. Social and Personality Problems

Opinions of anthropologists, who have studied and lived with civilized and primitive races all over the world, should widen our understanding of this fascinating problem of races. Let us quote a few sentences from Linton, who has studied groups in Madagascar, the South Sea Islands, and Alaska. [16]

One rarely encounters an ethnological field worker who believes that the native group which he knows best is inferior in intelligence to Europeans. Although many of these workers believe that there are racial differences in intelligence, they prefer to ascribe inferiority to groups with whom they have never worked or whom they know only slightly. At most, certain groups may have a somewhat larger percentage of brilliant individuals than others. The bulk of individuals in all races are probably intelligent enough to acquire mechanized civilization and transmit it without any important additions or losses just as does the bulk of the modern white population. The growth and spread of civilization has gone on with a serene indifference to racial lines. All groups who have had an opportunity to acquire civilization have not only acquired it but also added to its content.¹¹

Regardless of appearances, it cannot be said that any race has definite inferiority if its members are capable of adapting to a complex society within one generation. And this can be done. American Indians, Tibetans, Central Africans could make such adjustment. Hence, if some races or nationalities are inferior, it is probably because of long-continued isolation and depraved living conditions. For many centuries the natives of India have lived in such utter squalor—overpopulation, poor land, and bleeding by tax-hungry rulers—that their fundamental

¹¹Linton, R. *The study of man*. New York: D. Appleton-Century Co., 1936, p. 54

ability may possibly have been lowered. On the other hand, it is more likely that each separate individual is a victim of his own poor environment.

Questions about personality differences among nationalities bring up so many problems that it is impossible to touch upon all of them here. Most differences are certainly acquired through local customs. Travelers in the Near and Far East often become convinced that the natives are innately dishonest, because they overcharge, cheat when they can, and pass counterfeit money. But one soon learns that commerce is a game of wits with them, as with the old-time horse trader. They see nothing inconsistent about A's paying twice as much for a suit as does B. B is just that much more clever and persistent. They think we are foolish to have fixed prices. Those visitors who comprehend their modes of reasoning sympathize with them, and when they return home occasionally apply the "bazaar techniques" on our own merchants, with surprisingly satisfactory results.

What about the supposed differences among white groups? The British appear to be stiff and conservative, Americans loud-mouthed and inclined to backslapping; French and Italians are vivacious and emotional; Swedes are less expressive and unemotional. Are these inborn traits? There is no evidence for it. If such differences are genuine, and there is even doubt as to that, they must be regional rather than racial. Those living in the south are usually more expressive, gay, and romantic in temperament than those living in colder climates. This is reflected not only in their personal behavior, but in what they do, such as the use of color in architecture. On the other hand, Linton points out that explorers find all sorts of personality types among native servants, whose mannerisms frequently remind them of certain friends at home.

An instructive study was undertaken with respect to the gestures used by members of various races living in New York City. [8] Motion pictures were studied very carefully to detect possible patterns. It was found that Italians tended to be symmetrical in their movements and to continue a motion until it had been finished. Jews, on the other hand, used asymmetrical movements, and were more jerky and tended to interrupt them before they were completed. The Italian used his whole arm, while the Jew used the forearm, sometimes only fingers, and punctuated his remarks by head movements. Finally, among members of nationalities that had been more assimilated, such gesticulations were less pronounced and less conformant to the typical patterns. This study demonstrates the learned character of such items of behavior.

III. SEX DIFFERENCES

(A) **GENERAL ABILITY.** There is always a lot of good-natured argument about whether men or women are more intelligent. Each sex seizes opportunities to cast aspersions upon the other. It used to be thought that woman was inherently inferior to man. In fact, in many societies she was as much his chattel as were his beasts of burden. Even in our country women were denied higher education until 1820, and the first state university to admit women on an equal basis was the University of Michigan in 1870. Woman suffrage was not granted until the Nineteenth Amendment to the Constitution was passed in 1919. Up to the last many men had insisted that women could not think maturely enough to vote intelligently. Actually, if voting by emotion and prejudice were cause for disfranchisement, as many men as women would lose their votes.

Actual results of tests have shown men and women to be as nearly equal as two groups could be. As evidence, we quote averages, medians, and standard deviations of the scores of over 30,000 high school seniors in the state of Wisconsin. [12]

TABLE 27
INTELLIGENCE SCORES OF BOYS AND GIRLS IN HIGH SCHOOL

	Averages	Medians	Standard Deviations
Boys	166.28	163.48	45.93
Girls	165.61	163.62	43.54

One notices that the standard deviation for the boys is a little larger than is that for girls. This is a statistical term we have not previously used. It is a measure of variability, or the spread of a group. A homogeneous group, such as a single school grade, would have a very small standard deviation (abbreviated " σ ") in respect to age, but a movie audience would have a large σ , as all ages are present. This, then, suggests that boys are more inclined to score high and also more inclined to score low on an intelligence test. This trend is slight, and since it does not always appear, it must be largely discounted.

Are there, then, more bright and more dull boys than girls? Let us glance at both ends of the scale of achievement. Very few women have made their marks in history. In a list of the 1,000 most eminent persons in the world, only 32 were women, and many of these achieved their fame by being hereditary sovereigns, beauties, and so on. We

should recognize, however, that social conditions make it difficult for a woman to achieve eminence: many of the highest professions are still virtually denied to them, employers do not often promote them to positions of responsibility, and the bearing of children interrupts the careers of all but the most determined (Madame Curie was a notable exception).

At the other end of the scale we find more boys and men in institutions for defectives. This situation may be partially social. Families tend to support backward girls, but are not hesitant about committing an unpromising boy. Also, a boy's true ability is tested when he has to earn a living; a girl may remain at home and keep house or become a domestic servant, even though she has less ability than is required for success in other vocations.

Girls mature earlier. They learn to talk at an earlier age, not only among average children but also in the brilliant and dull normal groups. Comparisons of IQ's at various ages consistently show the girls leading up to about twelve or thirteen, after which the scores become equal.

(B) **SPECIAL ABILITIES.** So far we have discussed comparisons of general intelligence, taking the total scores as units. What about performance on the various parts of the test, or in various school subjects? On the average, girls are better in subjects demanding verbal facility and memory, such as English, languages, literature. They tend to excel in rote learning; that is, in learning routine material such as dates or lists of rules. Boys, on the other hand, are consistently better in logical, informational, and scientific subjects: geography, history, sciences, mathematics. They are far better in shopwork and other courses where mechanical facility is required, although this is probably more a matter of interest and experience than an innate difference.

Girls usually earn higher averages in school, even though they average the same in intelligence. They study more regularly and faithfully, are more willing to commit things to memory, and follow directions more explicitly. Boys usually do better in writing original essays and in handling problems involving originality, where no method or direct answer is suggested in class or in the text.

Since there are these differences in special subjects, one might imagine that it would be possible to make up a test which would favor either girls or boys as one desired. The Army Alpha test was given in several colleges to entering freshmen in the years right after the war, and girls consistently scored a few points lower than boys. But this test was made up for army men, and it contained some information items on science and sport which were unfair to the girls. In making up a test, care is taken to avoid items clearly favorable to one sex, or

at least to have them equal in number. For instance, if we asked: "Who was the heavyweight champion before Dempsey?" or "Where is the king-pin on an automobile?" we would be unfair to the girls. On the other hand, these descriptions from a society page preceding a college dance undoubtedly mean something to the girls, but to most men no tangible images are conjured: "A dusty pink princess dress of heavy corded silk rep, trimmed at the neckline and hem with silk fringe, will be worn by . . ." and ". . . will appear in a white moiré taffeta frock, featuring drop shoulders."

Finally, we must emphasize the fact that in every case differences between individuals are much greater than between the averages of the sexes. This is entirely true of averages, and almost as true with special subjects. Even if boys may be a little better in chemistry and girls excel in English, we find both boys and girls with A's and failures in each subject.

By way of summary, we list the following conclusions: (1) Men and women have the same averages on intelligence tests. (2) Women are slightly better in verbal abilities, men in scientific pursuits. (3) Men are slightly more variable. (4) Individual differences are far greater than sex differences. (5) What *intellectual* differences there are may probably be accounted for almost entirely by environmental pressures. We have already (Chap. XII) seen this to be true with personality traits.

IV. AGE DIFFERENCES

The saying "You can't teach an old dog new tricks" applies especially to the field of learning, but there is the suggestion that a person becomes less alert and less flexible in all pursuits as he grows older. If such a decline occurs, just when does it start, and how serious is it? This was studied by Miles and Miles as one of the phases of an extensive study of older people in California. They found IQ's as given in Table 28. The scores (we hesitate to call them "intelligence" before we scrutinize carefully) are seen to drop about as soon as they reach their peak around twenty. This drop starts slowly, and progresses more steeply after fifty or sixty. A second noticeable trend is an earlier and more severe decline among those of lesser education.

It is hard for many to believe that a middle-aged person has slipped as much as this table would suggest. The figures force us to the conclusion that governors, members of Congress, and heads of great business concerns are chosen when their abilities are not at their peak but are actually declining.

TABLE 28
 AVERAGE IQ'S FOR VARIOUS DECADES OF LIFE [19]

Age	0-8 Years Schooling	9-12 Years Schooling	1 or More Years College
20-29	101	107	118
30-39	94	106	116
40-49	93	105	117
50-59	89	100	111
60-69	85	95	106
70-79	82	95	100
80-89	75	85	

Many people become "mentally rusty." Maximum mental performance comes at about the time education is finished. Many people go into occupations which have few intellectual demands, and often they fail to do any stimulating reading. This is especially true of those who have had comparatively little formal schooling: Table 28 shows that they decline earlier and more. Those who have been to college tend in the main to enter the more exacting vocations. Probably persons who enter scholarly vocations, such as teaching, law, medicine, ministry, where one must keep up to date and alert to enjoy continued success, maintain a high mental level long into their elderly years. Standard deviations of scores in older people show that some people keep up while others slip more seriously as they grow older.

Another bit of evidence for "mental rustiness" is seen in the fact that women show an earlier decline than men. They start to drop at any early age and drop more rapidly. This can only be explained on the basis of the less stimulating environment in which most women live. A woman who spends her days cooking and caring for children will not receive the intellectual stimulation that her husband is likely to receive in office or professional work. Women who keep alert and active in outside affairs need not drop so early.

Confirmatory evidence has been reported on a group of older students, many of them mature teachers who were taking extension courses. [23, 24] Those who had done other advanced work recently did better in several tests of learning than did others who had not attended any classes for several years. The tentative conclusion was that people up to fifty should show no loss in learning ability provided they keep in practice, and that those who are "rusty" can recover their former speed and ease of learning with practice. This latter conclusion suggests another reason why people decline in ability: the test is usually a single short test which, if a person is out of practice, gives no more a

true measure of ability than would a man's golf score on the first round after not playing for ten years.

An additional handicap for older people is the speed demanded in intelligence tests, just as it is a handicap for people who do not know the language thoroughly. In this case it is a personality matter; older people tend to be more cautious and not so slapdash as a high school or college student. Also, it is difficult to motivate a mature person to try hard, while most college students rise well to the spirit of competition.

SUMMARY

We have seen that differences in intelligence signify much more than the ratio between IQ's. *Feeble-mindedness* is indicated both in slower mental growth and in reaching the peak of development at an earlier age. Dull people are retarded in the higher and more complex processes of abstract reasoning, arithmetical problem solution, and generalization more than they are in routine performances. The large majority of feeble-minded need guidance to be self-supporting, and are usually restricted to casual labor jobs. They do not have any characteristic personality failings. Most are placid and easygoing, and few of them are more vicious or criminally inclined than normal persons.

Superiority is manifested from an early age, and is characterized by consistent acceleration and continued mental growth to at least eighteen or twenty. Gifted children are accelerated intellectually, advanced in school, come in the main from better-class families, have superior physical development and health, have more intellectual interests and hobbies, are especially outstanding in amount and quality of books read, and have normal personality traits. In early maturity they justify all earlier predictions as to intellectual, educational, and physical pre-eminence, and have more scholarly interests. These data tie up with estimated IQ's of famous men in history. In general those whose fame was derived from intellectual contributions had IQ's ranging from 140 to 200. Genius is not specialized; abilities are well rounded.

Then we discussed and compared group differences: race, sex, and age. We found it necessary to differentiate carefully between the scores earned on tests and genuine ability. Those of Northern European stock make higher scores, but it appears that this superiority may be accounted for largely on the basis of the composition of the tests themselves or on the stimulating quality of their environments. Any genuine differences are probably temporary, and would be likely to be reversed if environments were interchanged. The slow progressive drop in scores of older people is more a matter of "mental rustiness" than a

genuine decline in native ability. The two sexes are on a virtual par in total intelligence scores. Women tend to be slightly better in linguistic and memory functions, while men excel by slight margins in scientific, mechanical, and informational subjects.

REFERENCES

1. Alexander, H. B. A comparison of the ranks of American States in Army Alpha and in social-economic status. *Sch. and Soc.*, 1922, 16, 388-392.
2. Anastasi, A. *Differential psychology*. New York: The Macmillan Co., 1937. Chapters XIV-XVIII.
3. Baller, W. R. A study of the present social status of a group of adults, who, when they were in elementary schools, were classified as mentally deficient. *Genet. Psychol. Monogr.*, 1936, 18, 165-244.
4. Byrns, R. Intelligence and nationality of Wisconsin school children. *J. soc. Psychol.*, 1936, 7, 455-470.
5. Cattell, J. McK. A statistical study of eminent men. *Pop. Sci. Mon.*, 1903, 62, 359-377.
6. Cox, C. M. *Genetic studies of genius*, Vol. II. The early mental traits of three hundred geniuses. Stanford University, Calif.: Stanford Univ. Press, 1926.
7. Doll, E. A. Idiot, imbecile, and moron. *J. appl. Psychol.*, 1936, 20, 427-437.
8. Efron, D., & Foley, J. P., Jr. Gestural behavior and social setting. *Z. Sozialforsch.*, 1937, 6, 152-161.
9. Freeman, F. S. *Individual differences*. New York: Henry Holt & Co., 1934.
10. Garth, T. R., & Garrett, J. E. A comparative study of the intelligence of Indians in United States Indian schools and in the public or common schools. *Sch. and Soc.*, 1928, 27, 178-184.
11. Harlow, H. F., & Israel, R. H. Comparative behavior of primates. IV. Delayed reaction tests on subnormal humans. *J. comp. Psychol.*, 1932, 14, 253-262.
12. Henmon, V. A. C., & Holt, F. O. A report on the administration of scholastic aptitude tests to 34,000 high school seniors in Wisconsin in 1929 and 1930. *Bull. Univ. of Wisconsin*, 1931.
13. Hildreth, G. Characteristics of young gifted children. *J. genet. Psychol.*, 1938, 53, 287-311.
14. Hollingworth, L. S. Do intellectually gifted children grow toward mediocrity in stature? *J. genet. Psychol.*, 1930, 37, 345-360.
15. Klineberg, O. *Race differences*. New York: Harper & Bros., 1935. (The whole book is full of material, critically evaluated. We have made particular reference to Chapters VIII and IX, and page 367.)

16. Linton, R. The study of man. New York: D. Appleton-Century Co., 1936. P. 54.
17. Louttit, C. M. Clinical psychology. New York: Harper & Bros., 1936. Especially Chapters IV-VI.
18. Miles, C. C. Intelligence and social adjustment. *Ment. Hyg.* (N.Y.), 1938, **22**, 544-566.
19. Miles, W. R., & Miles, C. C. The correlation of intelligence scores and chronological age from early to late maturity. *Amer. J. Psychol.*, 1932, **44**, 44-78.
20. Oliver, R. A. C. The comparison of the abilities of races with special reference to East Africa. *East African Medical Journal*, 1932, 160-175; 193-204.
21. Pintner, R. Intelligence testing. New York: Henry Holt & Co., 1931.
22. Pressey, S. Psychology and the new education. New York: Harper & Bros., 1933. P. 211.
23. Sorenson, H. Adult ages as a factor in learning. *J. educ. Psychol.*, 1930, **21**, 451-459.
24. Sorenson, H. Mental ability over a wide range of adult ages. *J. appl. Psychol.*, 1933, **17**, 729-741.
25. Terman, L. M. Genetic studies of genius. Vol. I. Mental and physical traits of a thousand gifted children. Stanford University, Calif.: Stanford Univ. Press, 1925.
26. Terman, L. M. Genetic studies of genius. Vol. III. The promise of youth. Stanford University, Calif.: Stanford Univ. Press, 1930.
27. Wembridge, E. R. Life among the lowbrows. Boston: Houghton Mifflin Co., 1931. Chapter I.

XVIII

HEREDITY AND ENVIRONMENT

1. Difficulty of Separation

Intelligence, it has already been pointed out, is largely innate. Chief evidence of this is that a person occupies roughly the same relative position in his group throughout his life. On the other hand, a learned ability may be altered within wide limits. But, since people usually remain in the same general environment during their life spans, no special force tending to alter the IQ is present. What would happen if such a force did exist?

Heredity and environment are not antagonistic forces, working against each other. They work together, supplement each other, and rarely conflict. A child born to a well-to-do family usually has the double advantage of good stock and excellent environment. The poorer child often comes from duller parents and is often handicapped by mediocre surroundings. Hence, recognizing that both heredity and environment operate upon each of us, let us try to discover the relative importance of each.

2. Family Trees

(A) EMINENCE. In Chapter XVII we saw that the "gifted children" came predominantly from families engaged in the higher occupations. This tendency has been evident in every similar survey. Over half of the three hundred historical geniuses, mentioned on page 357, came from professionals and the nobility, and less than a fifth sprang from skilled or unskilled working families.

Of still greater importance is the fact that high ability does not spring up singly. The "gifted children" had, as near or distant rela-

tives, a large proportion of the most famous men in American history. Galton [6] studied eminent men in England and found that they had equally eminent relatives 137 times as often as chance alone would suggest. The 977 eminent men he studied had eminent relatives as follows: 89 fathers, 114 brothers, 129 sons, 52 grandfathers, 57 grandsons, 53 uncles, 61 nephews—a total of 535. Galton estimated that if chance alone were the cause there would have been only four of that degree of eminence. He attributed all of this to heredity, ignoring the very favorable environment in which most of them were brought up. Environment, however, could not account for more than a small proportion of the difference.

A similar survey was made of the royal families of Europe. [23] In this study 671 individuals were rated from 1, imbecility, to 10, extraordinary capacity. Individuals of high ability centered for the most part around descendants of Frederick the Great, Queen Isabella, William the Silent, and Gustavus Adolphus. Deficiency was especially prominent in the royal houses of Spain and Russia, as well as certain other minor kingdoms. In several cases degeneracy of the royal family came after strong beginnings and was accompanied by crumbling of the kingdom. Austria, with its Hapsburgs, is an outstanding example.

In this country we can name a number of families in which several members have attained prominence: Adams, Roosevelt, Edwards, LaFollette.

(B) DEGENERATE TREES. A number of studies have been made on families rife with feeble-mindedness and degeneracy. Two of the best known are those on the Kallikaks and the Jukes—the names are purely fictitious. Investigation of the Kallikaks started when a psychologist inquired into the background of a defective girl who had produced many illegitimate children. [7] Such a web of degeneracy appeared that a thorough study was attempted. This family was found to have had its roots in an illegitimate offspring of a feeble-minded barmaid by a soldier in the Revolutionary army. Among 480 descendants about whom some information could be obtained there were 143 feeble-minded, 292 of unknown ability, 36 illegitimate, 33 prostitutes, 24 alcoholics, 3 epileptics, 82 died in infancy, 3 criminals, 8 keepers of disreputable houses, and only 46 of the whole lot were normal. This family of Kallikaks is said to have cost the state in which it resides several million dollars in institutional support. After the war, the same soldier married a respectable normal girl, and of this line only 5 could be considered abnormal in any way—2 alcoholic and 1 each mentally deficient, immoral, and afflicted with religious mania.

The Jukes present a similar picture. Among 1,200 there were 310

paupers, 7 murderers, 80 habitual thieves, 50 prostitutes, 130 convicted of crime, 300 died in infancy, and 440 were physical wrecks from debauchery. Only 20 ever learned a trade, and 10 of these learned it in prison! Several other families show similar pictures of deficiency, but these two samples will show what may happen.

When these studies first appeared, they were accepted as evidence of the power of heredity. Now we realize that such deplorable lines are produced by the combined action of bad stock and unfavorable environment. These studies have distinct limitations. Not only was there no actual testing, but accurate records were not available as in the case of the famous men of history. Evidence came entirely from verbal report, and from sources that must be regarded as untrustworthy, and easily suggestible to the prejudices of the interviewers. As one psychologist said, "Can I label an unknown person an alcoholic because some eighty-year-old senile dement vaguely remembers seeing Uncle Zeke Kallikak tossed out of a barroom sixty years before?" Further, since the total number of relatives is far in excess of 480, it is likely that the more normal individuals have been forgotten and that only those who had institutional records or were guilty of bizarre conduct were remembered.

3. Inheritance of Intelligence

(A) **PRINCIPLES.** Let us start with several general conclusions. (1) Intelligence follows roughly the abilities of one's parents. (2) It tends to revert back toward the median IQ. For example, parents of IQ of 120 each will have children with slightly lower abilities, while those of 80 will have offspring with possibly 90 IQ's. (3) It has also been suggested that children tended to follow one parent or the other, rather than representing an average of the two. For example, if people having IQ's of 120 and 80 married, their children would be either rather bright or rather dull, not just average. This hypothesis is difficult to verify, since most men marry women of similar culture and ability. (4) In any single case, practically any IQ may appear, although the probability is that it will be in the general range of the parents, and very seldom will there be any large departure. These four principles may appear somewhat contradictory, but it is quite likely that the last three are minor modifications of the first. One thing is certain: intelligence is not inherited as a unit trait.

(B) **INTELLIGENCE AND PARENTAL ABILITY.** One study was conducted by selecting 51 families, English speaking, literate, and having four or more children. [15] Various occupational levels were represented. In Table 29 we show the major comparisons.

TABLE 29

IQ DISTRIBUTION OF PARENTS AND CHILDREN ACCORDING TO OCCUPATIONAL CLASS

	Professional	Business; Clerical	Skilled Labor	Semiskilled	Unskilled
Parents	128	120	105	91	87
Children	125	117	104	95	96

In terms of a correlation coefficient, the relation between the average of the parents and the average of the children (four or more) was $+.80$. The nature of this computation gives a slightly higher figure than would be generally characteristic for parent-child correspondence, since it involves averages on the part of both parents and children, and hence balances out individual discrepancies. But there is no question that a high degree of correspondence is demonstrated.

(C) INTELLIGENCE AND PARENTAL OCCUPATION. This last study might be criticized on the basis that intelligence tests of adults are not as yet entirely satisfactory. Since it is only within the past ten years or so that intelligence tests have been administered to the great bulk of children, a better idea of parent-child relationships will be obtained when the children of those who were originally tested in school are also tested in their adolescent years. Testing parents as adults introduces complications previously pointed out. In the meantime we can obtain a fairly good, but indirect, index of the relationship between parent and child by studying the correlation between father's occupation and child's score. Vocation is not a perfect index of ability, but in the long run it is quite accurate.

Such a study, done on over five hundred children, is summarized in Table 30. [10] The line "IQ median" gives the best single summary, and shows that there is a decided relationship between the intelligence of children and their fathers' occupations. The professional men have children with median IQ of 113; the executive and business class a little lower, 108; the skilled and clerical workers have offspring with IQ of 98; and the semiskilled and unskilled fall well below, with 84 and 76, respectively. The other summary figures show the same trends, expressed in various ways. It will pay the reader to study the table and the summary figures carefully.

Of equal importance, however, is the fact that the intelligence of individual children within each group lies over a wide range. Not all the professional men have children with IQ of exactly 113. Some, but not many, are subnormal; others are very superior. *It is possible for*

TABLE 30
THE RELATION BETWEEN IQ AND PARENT'S OCCUPATION

IQ	Group I Professional	Group II Executive, Business	Group III Skilled and Clerical	Group IV Semiskilled	Group V Unskilled
145	1	2			
140	1	1	2		
135	1	4			
130	4	3			
125	3	3	4		
120	5	12	11		
115	5	16	18	1	1
110	5	29	12	4	1
105	8	19	37	1	2
100	2	17	30	6	
95	4	16	30	4	4
90	2	12	31	4	2
85	1	9	25	10	9
80	1	8	24	10	8
75		1	15	8	21
70	1	2	11	6	15
65			3	4	12
60			1	3	8
55				3	5
50				1	1
45		1			1
Total	44	155	254	65	90
Per cent	7.2	25.2	41.8	10.7	14.8
IQ range	70-150	45-150	60-140	50-115	45-115
IQ median	113	107.5	97.5	84	75.7
Per cent superior IQ	56.8	45.1	18.5	7.7	2.2
Per cent average IQ	36.5	41.3	50.4	23.1	8.9
Per cent subnor- mal IQ	7.7	13.6	31.1	69.2	88.9
Per cent above to- tal median	84.0	75.0	52.0	22.0	7.0
Per cent below to- tal median	16.0	25.0	48.0	78.0	93.0

any IQ to appear in any family. Maybe once in a million times two feeble-minded people might produce a genius, and occasionally a president of a university will be unfortunate enough to have a defective child. But less wide departures occur more commonly. In a family of ten children, we might expect perhaps six to be close to their parents, and possibly two would be brighter and two duller than the rest. If a certain family has not been especially successful in an economic way, it is not safe to assume that every one of its members has limited possibilities.

4. Adopted Children

In every case the evidence we have quoted demonstrates the potency of heredity plus environment. It is utterly impossible to isolate the factor of heredity, since the great majority of people are raised by their own parents. Recently several investigators have at least partially separated the two influences by studying adopted children. Thus, we have one heredity and a different environment. It is ideal for scientific purposes where identical twins are adopted into different classes of homes.

Two extensive studies on adopted children have been conducted, one in California [2] and the other in Chicago. [5] The fundamental question is: How much will the IQ of a child be raised (or reduced) by transfer from one environment to another? We suggest "raised" advisedly, since the IQ almost always does increase. The reason for this is that most adopted children are from poor families, foundlings, or illegitimate. They are usually adopted into better homes, since people who wish to adopt children are usually sound financially, and since well-run institutions investigate carefully the ability of prospective foster parents to furnish a good home.

Where possible, intelligence tests are administered to all persons concerned: true parents, foster parents, the child himself both before and several years after adoption, true brothers and sisters from whom he is separated, and own children of the couple in the home into which he is adopted. As can readily be appreciated, all such scores are not always available, but comparisons are made on as many as can be obtained.

Very similar conclusions were reached in both California and Chicago studies. Change from a poor to a good environment, adoption from a working family to that of a professional or well-to-do businessman, raises the IQ about ten points, and in rare instances as much as twenty points. One might say that inheritance determines the general range of intelligence and that environment sets the exact point.

Other conclusions substantiated this general principle. First, those

placed in better homes gained more than those living with medium families, the IQ's being 95 and 86, respectively. The ratings of adopted children were also compared with the occupation of the foster father, with these results:

TABLE 31
INTELLIGENCE OF CHILDREN ACCORDING TO THE OCCUPATIONAL STATUS
OF THEIR FOSTER FATHERS

Occupational Class	Number	Average IQ
Professional	61	107
Semiprofessional and business	160	101
Skilled labor	149	92
Semiskilled	19	85

Comparing with Table 29, which gave similar figures for own children, we see that in all but the semiskilled class the adopted children fall below true children. Favorable environment helps, but it cannot entirely make up for mediocre heredity. This is further substantiated by the fact that true children test much higher than do adopted children in the same homes. In the Chicago study the figures reported were 112 and 95, while the California findings were 115 and 107. The difference is in the same direction in both cases, although it appears that the California adopted children were of somewhat better stock.

In terms of correlations, we cite comparative coefficients from two different studies.

TABLE 32
CORRELATIONS OF INTELLIGENCE SCORES [5, 13]

	FREEMAN	LEAHY
Adopted with own children in same home.....	+38	
Two adopted in same home.....	+40	
Two own children.....	+50	
Mid-parent and adopted child.....	+18	+21
Mid-parent and own children.....	+35	+60
Siblings adopted into different homes.....	+25	
Adopted child and rating of home.....	+48	+51

Thus we see undeniably that there are environmental influences. Otherwise the correlations involving adopted children would be zero. But where there is similar heredity and environment there is better agreement than where only one force pertains.

Two other facts, and ones which may have tremendously important implications, are that the longer the period of adoption the more effect upon intelligence there will be, and the younger the child is at time of adoption the greater the change. This has been the basis of an exten-

sive series of experiments at the University of Iowa, as a result of which the investigators feel that intelligence is largely environmentally produced. [22] The critical point, they suggest, is that adoption must come almost immediately after birth to separate effectively heredity from environment. Even if a child remains with his own parents for only a year, he has that heredity and environment combined before entering into his new environment. The older he is when he moves into his new home the less effect its stimulating qualities will have. The Iowa investigators have insisted upon early adoption, usually under three months of age.

Most astounding results were obtained in testing adopted children whose true mothers were feeble-minded. [21] The average IQ of the mothers was 66, while the children who were adopted into excellent homes averaged 111, and those adopted into good homes averaged 104. This would suggest almost limitless possibilities of shift. But there are one or two counter-arguments. First, only the mothers' abilities were considered. Many of these children were illegitimate, and studies have shown that in such cases the mothers are often dull, but the fathers are a representative group. The average of the two parents might suggest a child's IQ of possibly 85. Also, we cannot be sure that the mothers' IQ's were truly as low as that. People of lesser ability tend to quit school early and engage in non-intellectual activities, which cause the intelligence score to drop (remember our discussion of the influence of age upon ability). At an earlier time the same mothers may have had IQ's well into the 80's, or even higher.

A crucial argument is the fact that people of high socioeconomic status do occasionally have defective children. Even college professors, of a high degree of intellect and providing homes where intellectual interests are emphasized, sometimes have offspring who are unable to do college work. Also many people have risen decidedly above their environmental levels. A strongly environmentalistic interpretation would allow a person only to equal the quality of his surroundings, and not to exceed it by a wide margin as has been the case with many distinguished men who have risen from mediocre families. But these arguments cannot discount all the implications of these experiments. Although final evaluation of the relative influences of heredity and environment has not been determined, there seems little doubt that extremely early adoption permits much greater changes in intelligence level than we have thought possible.

These findings were confirmed in a study of seventy-three children placed in homes under the age of six months, with an average age of placement two months of age. [19] The median IQ of their true

mothers was 87. The true parents' education was slightly less than ten years, while the foster parents had been to school an average of 11.6 years and were of distinctly better economic status. The children at the age of about two years had an average IQ of 115. At that time the correlation between children's ability and that of their true mothers was exactly zero.

Parallel evidence was obtained in a study of the relation between length of residence in New York City and IQ of ten-year-old Negro boys and girls. [12] Age is thus controlled; the remaining variable is the length of time spent in the more stimulating environment of the big city.

TABLE 33
IQ AND LENGTH OF NEW YORK CITY RESIDENCE

Group	Number of Cases	Average IQ
Less than one year.....	42	81.4
1-2 years	40	84.2
2-3 years	40	84.5
3-4 years	46	88.5
More than four years.....	47	87.4
New York born	99	87.3

At least two attempts have been made to evaluate in terms of percentages the relative influences of the two factors. After complex statistical analysis, Burks [2] arrived at these figures :

	Per Cent
Home environment contributes	17
Parental intelligence contributes	33
Random physical effects of environment	5-10
Innate equipment in that individual, only indirectly hereditary	40-45

Totaling the two environmental effects gives 22 to 27 per cent.

In the other study Leahy paired 194 adopted children with the same number of own children. [13] The adopted children were selected on the basis of having been placed under six months of age; as being of the white race, non-Jewish, and of Northern European extraction; adopting parents of the same origin; between five and fourteen at time of testing; and raised in communities of one thousand or more. A control child was chosen to pair with each adopted child, as being of the same sex, within six months of the same age, father in the same occupational group, parents having had the same schooling within one year plus or minus, parents of the same racial antecedents specified above, and also residing in communities of 1,000 or more.

The IQ's of the adopted children averaged 110.5; of the controls, 109.7. Leahy finally concludes that home environment cannot account for more than 4 per cent of variation in IQ. This seems to be a low estimate, although we do notice that the environment is limited to that of the home in this case. It is *not* stated that the other 96 per cent is due to heredity. Even at that, I feel that there is no experimental or statistical justification for such a low figure for environment. No data on the status of the true parents were presented. The fact that between the ages of five and fourteen the adopted children had an IQ of 110.5 does not prove that at time of adoption their potential IQ's might not have been 100, or 90, or even 70. In every study of adopted children their original IQ's have been somewhere around the 90 mark.

Wellman, of Iowa, reports shifts of a great many points, in some cases from dull normality to superiority, from average to feeble-mindedness. [22] However, most of the initial scores in such cases were obtained when the child was from one to three years of age. Since tests at this age range must be of different character (chiefly in being less verbal) from those applied to older children, efforts at direct comparison must be recognized as not having perfect validity. So possibly shifts reported at this age, whether up or down, are not to be taken too literally. A final point is that, in spite of Wellman's strong environmentalistic convictions, she does believe that a child will have a general initial IQ or starting point, and that his final exact level within this range will depend upon various environmental pressures.

5. Studies on Twins

The limit in control of heredity and environment is reached in a study of identical twins brought up in different households. Since identical twins develop from the same female and male germ cells, it may be assumed that their heredity is the same in all respects; hence it may be ignored as if it were not present. Any differences between them must be due wholly to environment. Unfortunately for psychological purposes, twins usually live in environments as identical as their heredities. Even when they are adopted, they are usually taken together. One can imagine with what avidity psychologists have studied the few cases where twins were separated early in life and raised in different types of homes.

That twins are very much alike in ability may be seen by comparing correlations of $+0.50$ for intelligence scores of siblings with correlations of $+0.76$ for all twins and $+0.90$ for identical twins. The average differences in IQ are 4.8 for identical twins, 8.5 for fraternal twins (non-identical, may be of different sex), and 12 for siblings. Some cor-

respondences are truly amazing. [14] Each of a pair of twins separated at birth developed tuberculosis at eighteen. Another pair who did not even know of each other's existence, believing they were own children, each became a telephone repairman, got married in the same year, and each had a fox terrier named Trixie! Such correspondences in incidental behavior must not be uncritically assumed to be universal, however.

To see the methods used in studies of separated twins, let us examine several cases tested by Newman, Freeman, and Holzinger. [14]

CASE VIII. *Twins M and R*

Tested when 15 years old. Adopted at age of three months following mother's death. M adopted by maternal uncle, a bank president and former mayor of city of 5,000. Family in general is very intellectual. Her mother's sister lives next door; she is a school teacher and a university honor graduate. She took music lessons, and also reads widely.

R lived in a large city, and attended schools as good as M's. But her foster parents were less well educated and not cultured in any way. There were few books, no good music, and no intellectual activities in the home. Foster father was foreman of day laborers, with low income. Her social life has been limited, in contrast to a more stimulating situation for M.

Personality differences which might have some bearing on test scores resulted, M being eager and socially at ease, and R being timid and subservient.

Mental test records follow.

Tests	M	R	Difference
Stanford Achievement.....	14-7	13- 6	13 mos.
Stanford-Binet:			
MA	14-2	11-10	28 mos.
IQ	92	77	15 points
Otis IQ	101	86	15 points

CASE XVIII. *Twins J and R*

Tested at age 27. Born in a mountain village in Tennessee. Mother died in childbirth. Adopted by maternal and paternal grandparents, respectively. J's grandparents are of steady and industrious character, operating sawmill and sand and gravel business. J has worked as engineer with his company for ten years. High school graduate. Reads good literature.

R's grandparents are "regular mountaineers of the more primitive sort." Grandfather tried coal-mining, blacksmithing, and work on railroad, but not steadily. R went to eight grades, but in a five months' school, and showed little interest. Since then he has avoided work as much as possible.

Their test scores follow.

Tests	J	R	Difference
Stanford Achievement.....	16-0	13-1	35 mos.
Stanford-Binet:			
MA	15-4	12-4	36 mos.
IQ	96	77	19 points
Otis IQ	104	84	20 points*

*Newman, H. H., Freeman, F. N., and Holzinger, K. J., *Twins, a study of heredity and environment*. Chicago: Univ. Chicago Press, 1937.

In each of these cases we see great differences in cultural opportunities, with resulting discrepancies in the IQ which can theoretically be attributed wholly to environment. In another case, XI, the two girls were adopted into medium-class families. One was graduated from a good college, while the other twin was able to complete only three grades, because the foster father moved often and usually lived in isolated communities. The IQ's turned out, at age of thirty-five, to be 116 and 92. This difference was probably due to schooling, as is also seen in Case XVI. Maxine was brought up by a foster father of obviously limited intellect, small income, and scanty education. Her sister Virginia was brought up by a skilled laborer, but a man of apparently superior native endowment. In the sixth grade these sisters tested 90 and 88 respectively. Yet, in a similar case, where one sister had gone through high school and had taught school for several years before marriage and the other had gone through only five grades, there was practically no difference in scores at the age of thirty-two. These apparently contradictory results may be due to the same set of circumstances that causes twins reared together to have slightly different intelligence scores. If it happened that the brighter was adopted into the better family, two forces would combine to produce superiority. If the better twin were taken into the poorer family, the two forces might counteract each other and the result would be a virtual parity. As a final figure, the average IQ difference between these twenty pairs of *separated* twins was 8.2, which still is less than between non-twin children of a single family living together. So, all in all, it appears that, while environment can produce some discrepancies in the IQ of twins, a high degree of correspondence will always remain.

6. Environmental Limitations

(A) **BACKWARD COMMUNITIES.** A study was made in England of canal-boat children. Their environment was about as unfavorable as a person could imagine. The children lived in squalid barges in the

water-front district, moved from town to town, and hardly ever had a chance to go to school regularly. A striking fact was revealed by tests given to these children at various ages. The younger ones had IQ's around 90, but as they got older the score gradually sank to 60. [8] The stock thus appears to be only slightly inferior, but the children become duller (or cease to grow mentally, which reduces the IQ as the chronological age ascends) because of the complete lack of environmental stimulation. The same trend was reported among orphanage children. In one survey, where large numbers lived in one cottage under the supervision of an untrained matron and received virtually no individual attention, the IQ dropped 16 points, from 90 to 74, over a period of two years. [22] Another study obtained similar findings: 407 orphanage children who had scored in the low 90's up to the age of eight, dropped to 80 at ages thirteen and fourteen. [20]

An isolated community in the Blue Ridge Mountains not over a hundred miles from Washington, D.C., furnished parallel data. [18] The ancestry is good: Scotch-Irish, English, and German, but the people have been isolated for generations. In some hollows hardly any of the adults are literate. The children made an average of 61.5 on the Stanford-Binet scale. But these findings must be somewhat discounted, since, just as we saw with race differences, the test is not entirely fair to individuals with their lack of experience and opportunity. They almost universally failed tests involving calculation, partially because of inability to comprehend instructions. The influence of environment was demonstrated by the fact that the older children earned poorer scores than the younger. In another study, on East Kentucky mountaineers, the IQ dropped from slightly above 80 at age seven to nearly 70 at ages thirteen and fourteen. [11]

One asks, then, do these data invalidate the theory of the constancy of the IQ? Probably not. Although intelligence is largely native, its normal growth assumes a reasonably stimulating environment. Just as a man may lose physical strength by being confined to bed, so mental capability will not mature unless it is given a chance to develop.

(B) RURAL AND URBAN. People living in small towns and in the country score somewhat lower than those in cities. Since population trends have been from the farm to the city, it has often been assumed that the more alert and progressive young people migrated to cities in search of wider opportunities, but this is not true. Minnesota boys who left the farms were found to be lower in intelligence than their brothers who remained. Northern Negroes score higher than those who remain in the South, even though while in school they had earned equal grades.

Recent studies have shown that differences are narrowing; farmers

rate much closer to city people than formerly. This trend suggests that environmental limitations, which lessen as transportation and communication improve, have been entirely responsible. Soon we shall find that the farmer is entirely equal to the city man who engages in work of similar character. The traditional farmer who dressed like a "hick" is no longer to be found. His well-known daughter is as sophisticated, well dressed, and well oriented as her city cousin of equal means.

(C) DIFFERENCES BETWEEN STATES. Cattell has made several surveys comparing the relative numbers of eminent men who originate in various states, and has found wide differences. In 1903 in Massachusetts there were 109 distinguished scientists per million population, and 87 in Connecticut. [3] At the other end were Louisiana and Mississippi with 1.4 and 1.3. In 1932, however, the two leading states had experienced drops to 72 and 16, while Nebraska had gone up from 2 to 20, and Kansas from 7 to 32 per million. [4] There do not seem to be any material hereditary differences in the population of the various states, except for Negroes in the South. Therefore, local cultures and attitudes must cause the differences. Thirty years ago education was centered largely in the North Atlantic states; the South and the West accorded it less emphasis. Perhaps in another half century the differences will be greatly reduced.

The best comparison of residents of the states is from the Army Alpha test. We see from the table that the poorer states are mainly those in the South and those which contain large numbers of recent

TABLE 34

MEDIANS OF ARMY ALPHA SCORES, WHITE SOLDIERS [1]

Alabama	45.8	Maryland	56.1	Oregon	79.7
Arizona	(no cases)	Massachusetts	70.6	Pennsylvania	64.8
Arkansas	41.7	Michigan	63.3	Rhode Island	62.9
California	78.1	Minnesota	64.0	So. Carolina	47.4
Colorado	69.6	Mississippi	42.0	So. Dakota	58.3
Connecticut	73.6	Missouri	59.5	Tennessee	47.2
Delaware	49.5*	Montana	68.6	Texas	50.9
Dist. of Col.	78.7*	Nebraska	66.0	Utah	72.2
Florida	58.7*	Nevada	59.5*	Vermont	68.6
Georgia	42.2	New Hampshire	62.2	Virginia	56.3
Idaho	73.3	New Jersey	48.6	Washington	79.4
Illinois	63.8	New Mexico	59.5*	West Virginia	55.1
Indiana	56.1	New York	64.5	Wisconsin	56.6
Iowa	64.5	No. Carolina	43.0	Wyoming	77.9
Kansas	63.8	No. Dakota	57.0		
Louisiana	46.0	Ohio	67.2	UNITED STATES	58.9
Maine	62.6	Oklahoma	52.6		

*Less than 200 cases and hence not highly reliable.

immigrants, mostly laborers. It is interesting to observe, too, that the three Pacific Coast states occupy the first three places. This table was prepared from the scores of 40,530 cases.

(D) COACHING. Can the intelligence be raised by special training, say by coaching on tests? A group of children was given intensive training on the Stanford-Binet test, and their subsequent performances were compared with those of a group given somewhat similar practice and a control group, with results quoted in Table 35. [9] They gained a goodly number of points from the training, but its effect wore off almost entirely after a lapse of a year. This is very similar to the study on maturation quoted on page 56, where the trained twin was ahead a short time, but her sister soon caught up.

TABLE 35
EFFECTS OF COACHING UPON THE IQ

	Control Group	Group Coached on Similar Materials	Coached Group
At beginning	86	93	87
End of training period.....	90	100	110
After three months of no training...	92	102	105
After a year of no training.....	91	97	96

Further, it is apparent that only the *score* on the test increased, *not ability* itself.

Do pupils who take several tests have an advantage over those who take only one? Scores on the first test may be a little low, because of nervousness and unfamiliarity, but if subsequent tests are spaced six months or more apart there are no further gains from practice. [17] To make doubly sure of this, most tests are issued in two or more forms, so that the child will not be able to learn the answers to specific questions.

7. Influence of Physical Disturbances

Frequently a person attempts to excuse a mediocre score on the grounds of temporary or chronic illness: headache, stomach upset, too little sleep, infected tonsils, glandular disturbance. Most of these, authorities say, do not materially affect the test score. Students have been asked to indicate their general state of health when taking a test, but actual scores showed that there was little handicap from a headache, cold, or toothache. A person can overcome such distractions and do as well as at any other time, although, of course, if he fails to concentrate he will have a lower score.

Several studies on possible effects of diseased tonsils or adenoids have had negative results. In one case where a group of children was given a second test after a two-year interval, those who had had tonsillectomies in the meantime had gained no more than the rest. Apparently infection has to reach a toxic state before any material depression of intelligence occurs.

Blindness and deafness obviously cause severe handicaps in education, communication, contact with environment, and social participation. In addition, many congenital diseases not only involve sensory defects but are symptomatic of more widespread disorganization.

Deaf persons appear less intelligent than they really are, since they do not understand spoken language. Comparison of four thousand normals with over two thousand deaf showed the average IQ of the deaf, at ages twelve to fifteen, to be about 80, a retardation at this age of two or three years. [16] In educational tests the Educational Quotient (EQ) averaged only slightly more than 60, and language retardation is as much as four to five years.

Blindness superficially appears to be a worse handicap than deafness, and blind individuals receive more sympathetic treatment than deaf. However, blind children score only slightly less than sighted ones. Blind people range from superior to deficient, with the general averages only slightly below par. Contrary to popular belief, blind persons do not have superior acuities in other senses because they are blind. They may have learned to *use* touch, sound localization, and other senses more effectively than do sighted individuals, but apart from practice there is no greater acuity.

SUMMARY AND CONCLUSIONS

The reader may be rather uncertain as to the relative importance of heredity and environment. However, the author must confess that he can give no single summary answer.

The burden of evidence presented in this chapter has shown that intelligence is largely innate, partially inherited and partially peculiar to the individual himself. The most crucial bit of data is that transfer of a child from poor to good environment is accompanied by an increase in IQ of about ten points, and in extreme cases possibly up to twenty points. Greater changes, positive or negative, are almost invariably explained by extreme environmental conditions, physiological states, or emotional upsets.

Let us indulge in a bit of hardheaded reasoning. Although we have found that a change in environment may influence the IQ, such change

does not occur in any material proportion of cases. Following the normal distribution, a good quarter of the population will have scores of 90 or below. If all these are to be raised, we would have to turn the homes of all superior people into experimental laboratories. After all, the great majority of individuals are reared by their own parents. Slum clearance and the opening up of isolated communities gradually reduce the number of those far below average. But under any circumstances it is doubtful if enough people could be affected to better the level of the nation. We might also inquire whether such a move is desirable. Education beyond a minimum is said to unfit Indians for reservation life. Similarly, a general raising of the IQ might play havoc with an industrial order which demands people of all abilities and includes many unpleasant and strictly routine tasks that are ordinarily performed contentedly by dull normals.

For single individuals, our conclusions have more practical value. We know that a favorable environment can raise a person's level about ten points. This will lift him one step in the educational or vocational scale. A rise from 90 to 100 means that he can finish high school instead of having to stop after the grades, and can become an office worker or highly skilled mechanic instead of a semiskilled worker. Of course, this principle cannot be extended indefinitely. We could not hope to adopt a boy from a feebleminded family and make a lawyer of him, regardless of all the culture, private schooling, tutors, or anything else provided by the foster home. The child can absorb stimulation only in proportion to his capacity, which appears to be fixed.

A practical application of our data is in relation to possible adoption. Extreme care should be exercised in adopting a child. This is especially true for those well up in the economic scale. Few children adopted into professional families will be able to enter similar vocations. I have seen several heartbreaking instances of college professors adopting children and later finding them unable to finish college or even high school. The more intelligent the family the more distressing such failures usually are.

Adoption is often based on such whimsical reasons as blue eyes, curly hair, or slight resemblance to a deceased child. We realize that the new parent cannot be any more certain about the child's potentialities than he can be about those of his own children; nevertheless psychology furnishes several hints. If a person wishes to test the child he will have to wait until about the age of three, and preferably even five or six, to obtain truly accurate scores. If for sentimental reasons it is preferred to raise the child from infancy, we know that the earlier a child is adopted the more his intelligence will be raised by a favorable

environment. If an infant is to be adopted, care can be taken in two ways. First, find out all you can about his heredity; this does not insure a bright child but it increases the probability. Second, see what his motor development is. If he is slow in developing grasping and locomotion, beware. If he is average or advanced, chances of good intelligence are much better.

One last word. We have been discussing intelligence, and intelligence alone, in this chapter. Our conclusions with regard to the importance of the innate endowment apply chiefly to this phase of human behavior. We have already seen that, in the fields of emotions and personality, traits are almost wholly acquired.

REFERENCES

1. Army Alpha—Memoirs of the National Academy of Sciences, Vol. 15. 1921. R. M. Yerkes, editor. Washington, D. C.: Government Printing Office.
2. Burks, B. S. The relative influence of nature and nurture upon mental development; a comparative study of foster parent-foster child resemblance and true parent-true child resemblance. *Yearb. nat. Soc. Stud. Educ.*, 1928, 27, 219-316.
3. Cattell, J. M. A statistical study of eminent men. *Pop. Sci. Mon.*, 1903, 42, 359-377.
4. Cattell, J. M. The distribution of American men of science in 1932. *Science*, 1933, 77, 264-270.
5. Freeman, F. N., Holzinger, K. J., & Mitchell, B. C. The influence of environment on the intelligence, school achievement, and conduct of foster children. *Yearb. nat. Soc. Stud. Educ.*, 1928, 27, 103-218.
6. Galton, F. Hereditary genius. New York: The Macmillan Co., 1914.
7. Goddard, H. H. Feeble-mindedness: its causes and its consequences. New York: The Macmillan Co., 1914.
8. Gordon, H. Mental and scholastic tests among retarded children. London: Board of Education, 1923.
9. Graves, K. The influence of specialized training on tests of general intelligence. New York: Teachers College, Columbia Univ., 1924, No. 143.
10. Hildreth, G. Occupational status and intelligence. *Person. J.*, 1934, 13, 153-157.
11. Hirsch, N. D. M. An experimental study of the East Kentucky mountaineers. *Genet. Psychol. Monogr.*, 1928, 3, 189-244.
12. Klineberg, O. Race differences. New York: Harper & Bros., 1935. P. 186.
13. Leahy, A. M. Nature-nurture and intelligence. *Genet. Psychol. Monogr.*, 1935, 17, 236-308.

14. Newman, H. H., Freeman, F. N., & Holzinger, K. J. Twins, a study of heredity and environment. Chicago: Univ. Chicago Press, 1937.
15. Outhit, M. C. A study of the resemblance of parents and children in general intelligence. *Arch. Psychol.*, N. Y., 1933, No. 149.
16. Pintner, R. Intelligence testing. New York: Henry Holt & Co., 1931. Chapters XVIII and XIX.
17. Schott, E. L. IQ changes in foster home children. *J. appl. Psychol.*, 1937, 21, 107-112.
18. Sherman, M., & Key, C. B. The intelligence of isolated mountain children. *Child Develpm.*, 1932, 3, 279-290.
19. Skeels, H. M. Mental development of children in foster homes. *J. genet. Psychol.*, 1936, 49, 91-106.
20. Skeels, H. M., & Fillmore, E. A. The mental development of children from underprivileged homes. *J. genet. Psychol.*, 1937, 50, 427-439.
21. Skodak, M. The mental development of adopted children whose true mothers are feebleminded. Report at Midwestern Psychol. Ass'n, 1938.
22. Wellman, B. L. Our changing concept of intelligence. *J. consult. Psychol.*, 1938, 2, 97-107.
23. Woods, F. A. Mental and moral heredity in royalty. New York: Henry Holt & Co., 1906.

XIX

LEARNING

1. The Importance of Learning

A child enters the world with few innate psychological traits. His emotional habits and personality traits are acquired from his home environment. John Locke, in his *Essay Concerning Human Understanding* (1690), described the mind of a child as "tabula rasa," a clean slate. Others have likened the child's mind to a blank sheet of paper or a phonograph receiving record, ready to receive impressions from any source. In contrast, the adult's mind may either be rich with the full-bodied harmonies of symphonic music or as confused and discordant as the street noises at a busy intersection. The adult mind is a storehouse of material, things learned by reading, in school, through travel and conversation. The wisest person is he who can synthesize these impressions and develop a philosophy of life based upon the best he has seen and known.

But learning has a more immediate, if less lasting, value. It is a timesaver. When an act is well learned, the amount of conscious attention needed for its accomplishment is materially lessened. For instance, people carry on conversations while driving, read the morning paper while dressing or eating breakfast, and use a typewriter without having to look for each key.

2. Possibilities of Learning

Since learning is often erroneously assumed to consist solely in the acquisition of new knowledge, let us see what forms learning may actually take.

(A) **NEW ACQUISITION.** Although this is only one of the types of learning, it is the most common. When a year-and-a-half-old child

learns to speak the language, he starts from the beginning and laboriously builds a vocabulary and an understanding of sentence structure.

(B) MODIFICATION OF INNATE BEHAVIOR. Table manners and dancing illustrate this classification. Primitive people and animals eat, slowly or ravenously, according to their appetites. Civilized people have developed conventions about eating that add aesthetic enjoyment to mealtime. After a child has begun to walk, he can make all the movements used in social dancing. To learn to dance, then, he merely pieces together in a new sequence acts already learned.

(C) MODIFICATION OF A PREVIOUSLY LEARNED HABIT. New rules require changes of previous habits, in sports and in everyday life. Learning a language consists mainly in associating new sounds and symbols with familiar meanings.

(D) INHIBITION. Learning sometimes requires the elimination of certain habits or tendencies. Many parents develop inhibitions in their children by overemphasizing the "don't do this, don't do that" training. As the child grows older, he learns to withhold caustic comments, to refrain from eating with too great avidity, not to refer to certain family topics outside the home, and not to trespass upon the rights or property of others.

3. Progress of Learning: The Learning Curve

Except in the case of maturation, performance is improved through practice. Improvement may be graphically represented by learning curves.

(A) SHAPE AND CHARACTERISTICS OF THE LEARNING CURVE. Figs. 44 and 45 are typical learning curves. Both represent increases in skill: one through gain in output, the other through reduction in time. At first there is rapid improvement, then gains are made more slowly, and finally skill remains almost stationary.

(1) First, there is an *initial spurt*. In most acts the beginner improves his skill during the first few practice sessions. The score may improve as much during the first month as during the remainder of the year. It is comparatively easy to raise typewriting speed to thirty-five words a minute, but difficult, and even impossible for many, to gain from thirty-five to seventy. The initial spurt occurs chiefly because the rudiments of typing are simple, but also because the learner approaches a new task with enthusiasm, is delighted with the progress he makes, and transfers certain skills from previously formed habits.

(2) When the easier parts of a task have been mastered, the learner settles down to a comparatively *steady rate of progress* that is not quite so rapid as the initial spurt.

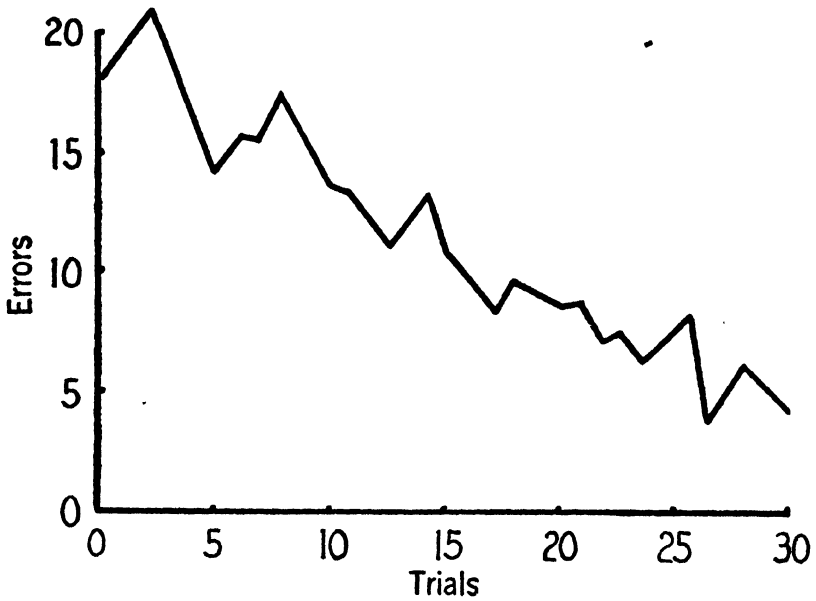

FIG. 44.—Maze Learning, Time.

Decrease of errors from trial to trial in a very difficult 40-turn maze. At first the usual 50-50 chance expectation prevails, but mistakes are gradually reduced. [11]

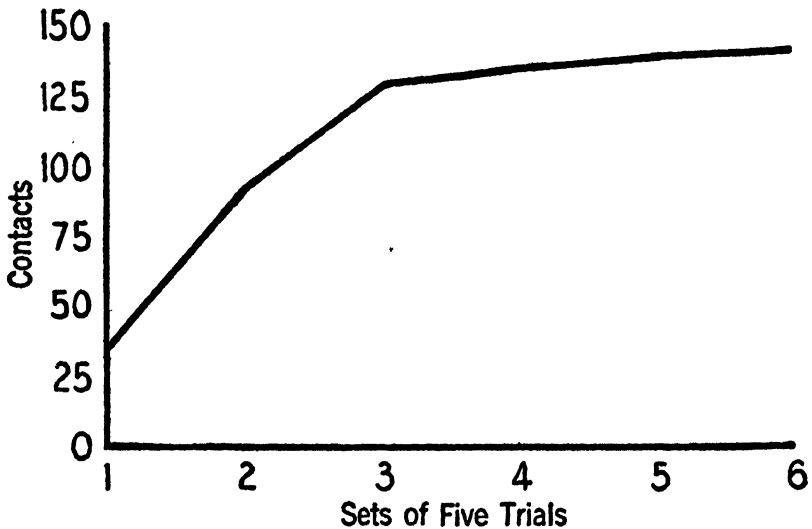

FIG. 45.—Improvement in Each Set of Five Trials on the Pursuit Rotor.

This instrument records by an automatic electric counter ability to follow with a pointer a brass disk about the size of a nickel on the edge of a rotating phonograph turntable. Notice that the improvement is rapid at first, less rapid later. [14]

(3) There then occurs a *tapering-off* period. Improvement is slow now.

(4) Finally, there is *no progress* at all. For the time being, at least, the learner has reached the limits of his capacity. However, he may subsequently increase his skill, a phenomenon we shall discuss in connection with plateaus of learning.

(B) PLATEAUS. These are periods when improvement ceases, no matter how great the effort. During these periods many people become discouraged and partially or wholly lose incentive to improve. Yet, if one persists in his efforts, the plateau is usually only a temporary stopping place from which a person enters a new and higher level of achievement. In Fig. 46 is shown a plateau, based upon a famous experiment in learning telegraphy code. [4] From the fourteenth to the twenty-eighth week there was little improvement in ability to receive code. This plateau was not exceptional, since it occurred in every instance reported by the investigators. In a group curve, like Fig. 46, the plateau is sometimes obscured because it occurs at different points with different learners.

There are several different situations which produce plateaus. (1) Better methods are necessary for the development of a higher degree of skill. In the telegraphy study it was discovered that the learner had attained about all the skill he could achieve with the methods he was

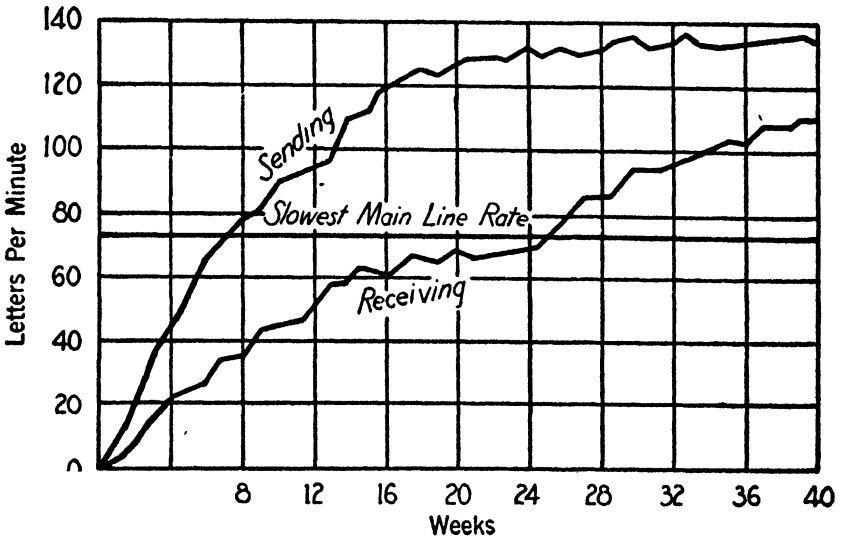

FIG. 46.—Plateau in Learning Curve.

Compare the shape of the receiving curve with that of the more typical sending curve. (From Bryan and Harter.)

using. To progress, it was necessary for him to learn to receive whole words instead of isolated letters. When he had acquired this ability, his speed improved considerably and his improvement was maintained until the conclusion of the study, many weeks later.

This principle operates both in school situations and in athletics. When one translates a foreign language, he cannot attain great speed so long as he must find the English equivalent for each word. To master a language one must be able to think in it; that is, to derive meaning direct from the French or German without using English. It takes time to achieve this skill, but there is no short cut to proficiency. In sports the person who receives expert coaching is more likely to become truly skillful. In golf, for instance, it is difficult to get below 90 without instruction, no matter how strong or graceful one may be. Criticism and instruction in better methods often make it possible to cut this figure. Without correction in technique, skill in golf, language study, or telegraphy is likely to be mediocre.

(2) Progress in learning is delayed from time to time while basic skills are automatized. In swimming the crawl stroke, several basic principles must be mastered so thoroughly that they can be carried through without conscious attention. Only then may one learn the finer details of form that distinguish the superior swimmer. Hence a separate plateau may appear as each major principle is assimilated.

(3) Plateaus also occur when the learner becomes bored or discouraged and loses motivation. At the beginning rapid improvement is made. But after a certain degree of proficiency has been attained, further gains come slowly and laboriously and the satisfaction derived from progress diminishes. In typing it may take as long to gain from fifty to sixty words a minute as it did to get to fifty from a start near zero. We sometimes become discouraged and give up the effort for improvement before we have really reached our physiological limit. Only when the reward is great will a person retain his motivation. The winner of the United States Open Golf championship may earn as much as \$50,000 within the ensuing year, but the man he has beaten by a single stroke probably will not earn a tenth of this. There is a great incentive to overcome the 1 per cent differential between winner and runner-up. For most of us, however, even a gain of 10 per cent would not put us in the championship class. Therefore, we are not motivated sufficiently to undergo the drudgery of daily practice.

(4) Interference between two sets of habits will temporarily prevent improvement. Retardation of improvement in motor skills may be produced by a faulty set of habits or by the practice of a skill which involves conflicting movements. For instance, a student of French

may have difficulties if he attempts to master German at the same time.

(5) Finally, a plateau occurs when a person reaches his ultimate limit and cannot improve, no matter how hard he tries or what methods he uses.

(C) LIMITS OF IMPROVEMENT. Can a person improve indefinitely or are there limits beyond which he cannot go? The question is really academic, since few people closely approach their limits. Only in simple tests of strength and speed, such as weight lifting and sprinting, have men come near the ultimate limits of human capacity. On the other hand, records in pole vaulting and bridge building are broken as fast as men master new techniques and devise better equipment.

Incentive to improve is absent more often than ability. Most of us are satisfied with a socially passable game of bridge, golf, or tennis. Since business demands most of our energy, we participate in sports only for recreation. If, however, competence in a sport is important to our livelihood (many salesmen develop a golf game for business reasons), we can usually develop superior skill.

In our daily work we seldom approach 100 per cent efficiency. When a person is under pressure he can accomplish much more in a given period of time. Retail salespeople work at high pressure during the Christmas season and munitions workers produce at a rapid rate under the double impetus of piecework wages and the patriotic slogans of wartime. Typesetters, with an average of fifteen years' experience, produced almost twice as much with a piecework rate incentive. Professional typists usually work well below their true limits. The present (1939) world's record is 144 words a minute for a half-hour period. Several stenographers, unaware that they were being timed, were found to average thirty to forty words a minute. It should be said in this connection that workers cannot function at peak efficiency constantly. When they are speeded up beyond their usual pace over a long period, elements of fatigue and monotony sap efficiency and often result in damage to machinery and goods. Many industrial plants have found efficiency was accelerated after the introduction of frequent rest periods.

(D) SUDDEN IMPROVEMENTS. Associated with the problem of plateaus is that of the sudden improvements that frequently appear. These improvements may have two causes. First, they may be produced by the discovery of better techniques or by the elimination of faults. Second, they may represent consolidation of techniques that have been learned. In the case of the telegrapher the plateau was certainly not a waste of time. In learning to receive single letters automatically he provided a foundation for the higher units. In some activities there are too many skills to be kept in mind at one time;

until these can be assimilated unconsciously the complete perfect act is not possible. For instance, a person must be an excellent skater before he can be a good hockey player. One football player barely made the third team during his sophomore and junior years; in his senior year he received All-American mention. Coaches frequently have difficulty in keeping an athlete's interest alive while he is on a plateau. Once he is over the "hump" he makes progress rapidly.

(E) DIFFERENT SHAPED LEARNING CURVES. It should not, of course, be assumed that all learning curves are like those in Figs. 47 and 48. Those curves apply especially to typing, telegraphy, or sports, situations in which learning is steady and gradual. In some types of learning improvement appears suddenly, and a high degree of skill is attained in a single jump or in a series of smaller jumps. An example

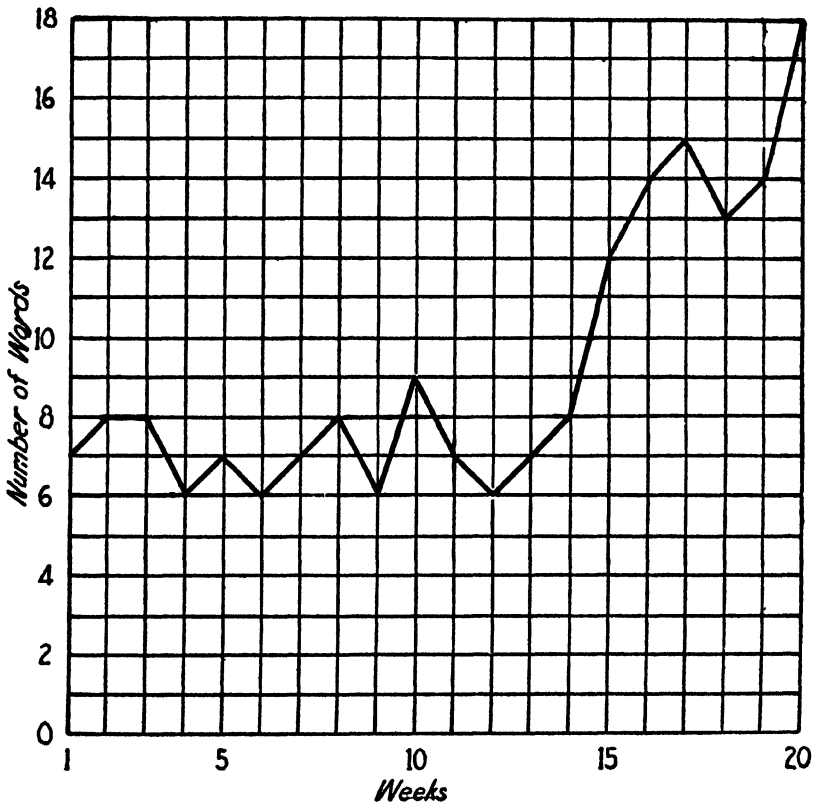

FIG. 47.—Sudden Increase in Skill.

Rapid improvement in spelling occurred when this deaf girl suddenly caught on to lip reading. (From Pressey, p. 321.)

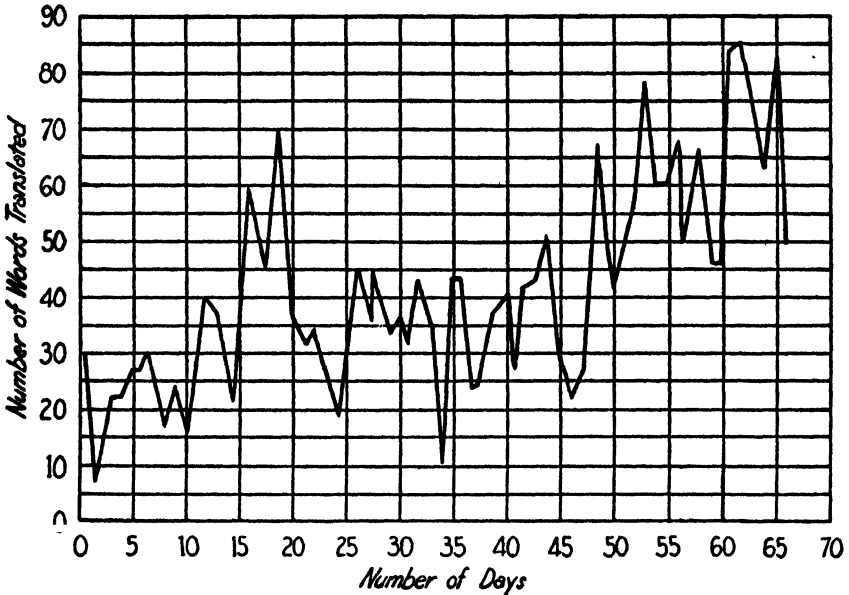

FIG. 48.—Improvement in Learning Russian.

The principal point of interest in this curve is the extent of fluctuation from day to day. While the general trend is upward, the differences between one day and another are large.

of sudden increase in skill is shown in Fig. 47. This is a case of a deaf girl who suddenly learned lip reading and thereby improved her accuracy in spelling. [25] Similar gains are noted in algebra problem solution. The student is given several problems of the same general nature, he solves the first few with difficulty, suddenly learns the principle involved, and finally writes equations and derives correct answers almost as rapidly as his pencil will move.

Motor abilities sometimes show the same sudden increase. In learning to ride a bicycle, one may fall off time and again, but when the trick of balance is learned, it almost never is forgotten. A father gave his ten-year-old son a bicycle for his birthday. The boy practiced an hour a day for several days but was unable to ride more than twenty feet without falling off. Suddenly, after a week's effort, he rode three blocks before he fell off. He soon became an expert rider.

Psychologists have generalized the types of activities that produce various types of curves. They suggest that slow increases in skill are associated with activities in which real comprehension plays no part. This is a *rote curve*. In contrast, there is the *insight curve*, denoting sudden improvement. Sudden comprehension or insight occurs when

a new technique of solution is discovered. We see evidences of this type of learning when the principle of balancing a bicycle is mastered, when a deaf girl learns to read lips, and when a telegrapher is able to receive whole words instead of isolated letters. On the other hand, there is no opportunity for insight in learning to type or to send telegraphic code.

(F) **MINOR FLUCTUATIONS.** Minor fluctuations appear in any learning curve, especially when it portrays the progress of an individual learner. A sample is shown in Fig. 43. This chart traces progress in learning the Russian language. [25] While the general trend is upward, there are wide variations from day to day, due to differences in difficulty of the material, distractions, state of health, and irregular motivation.

4. Association

Most of our learning is acquired through the association of new and previously learned materials. We learn certain foreign language words by associating them with the equivalent English words. Children learn words by associating sounds with objects and acts. We weave a network of associations about a friend: his appearance, his interests, his other friends, shared activities, and common experiences. All these are a part of the sum total which comes to mind when we hear his name.

Associations are unconscious as well as conscious. Many of the sudden memories that pop into our minds are explicable only in terms of unconscious association. While engaged in a routine act, one may think of a person or place far removed from immediate concern. Such thoughts may have been suggested by a passer-by who had not even been consciously noticed, or by some new element in the surroundings. Prejudices are often the result of unconscious associations with unpleasant experiences. One student said that he felt an active dislike for stocky, swarthy men, because a workman of this description had spanked him as a child. The origin of such feelings often is not consciously realized, but the prejudice has a lasting effect upon our attitude toward people.

Association operates among a large number of elements. You remember a melody quickly because one note is associated with all the rest. It acts as the *key* to memory. One incident at college may serve to remind us of a series of related experiences. If a person hears the word "hot," he may think in turn of summer, tennis, swimming, canoe, Mary, dance, lunch at midnight.

The remainder of this chapter will deal largely with the formation of associations. We shall discuss the efficiency of associations, and how they may be formed easily, effectively, and permanently.

5. Conditioning

So far in the book we have spoken chiefly of emotional conditioning, with special reference to the formation or removal of emotional habits. We have also touched upon personality conditioning, wherein traits are formed as a result of certain influences and pressures.

There is also a narrower use of the concept. Although "conditioned reflex" is one of the most frequently used terms in psychology, at the present time it is more valuable for theoretical work in learning processes than for promoting efficiency of learning in the classroom. The "conditioned reflex" became a well-known concept largely through the work of Pavlov, the famous Russian physiologist. [24] A conditioned reflex may be said to occur when a response has become so closely associated with a new stimulus that the original or native stimulus is no longer necessary. The classic example is Pavlov's experiment with a dog.

First, food (native stimulus) produces salivation (native response). Second, bell is rung, then food is presented, and salivation occurs. Finally, bell is rung and dog salivates; food is no longer necessary.

A substitute stimulus for food has been set up in the dog. But the conditioned reflex operates upon human beings as well. We do not require the sight or smell of food to bring us to the dinner table. Money is a substitute reward for goods and services it will eventually procure.

In human beings the kind of conditioning we have been discussing applies chiefly to minutiae of behavior. For instance the pupil of the eye contracts in bright light. By ringing a bell and flashing a light at the same time, it was found that a pupillary response to the bell stimulus alone was induced. [7] A verbal stimulus will also produce a response if trials are continued for a considerable period.

Although similar small bodily processes are usually involved in conditioned reflexes, the term is not limited to them. Substitute stimuli may affect the whole person rather than an isolated part. For instance, a person may be emotionally conditioned to like or dislike a particular song, people of a certain race, religion, or political affiliation, or a certain section of the world. His attitude toward these things is often conditioned by his first experience with them. It is as illogical as that. Despite our efforts to allay prejudice, most of us are slaves to our first impressions. If they are favorable, a multitude of unfavorable evidence is required to change our opinion, and vice versa.

6. Incentives to Learn

We have already discussed several of the incentives that inspire socially desirable behavior. Learning is desirable from any point of view, but definite incentives speed the learning process. No doubt some learning occurs without special desire, but such learning is usually inefficient and of short memory value. Unless we are actively motivated to learn, many of us take the easier way and our learning is haphazard, incoherent, and of doubtful value.

Certain principles of motivation may be applied directly to learning. They are: (1) Learning takes place faster when there is definite motivation or reward; (2) the more appropriate the reward the faster the learning; (3) if the score is known improvement is more rapid; (4) competition with others of the same age and general background speeds learning; (5) praise and reproof are better than no comment upon performance, but praise is better than reproof.

Stimulation of interest is an extremely important factor in education. Although many college students seem to have little interest in their work, they are not necessarily lazy or unwilling to learn. Often their seeming indifference really constitutes an indictment of the curriculum offered in that college. Since many have come to regard going to college as a necessity and not a privilege, it is small wonder that they enter classrooms reluctantly and with a "show me" attitude. Such disregard for education is rarely found among students of engineering or medicine, since these students feel that the subject matter of their courses will be directly applicable to their careers. Time spent in extracurricular activities clearly demonstrates the interests of undergraduates. They spend far more time on an article for the college paper than on a theme for an English class; they rehearse many tedious hours for a play but refuse to spend a comparable period in preparation for public speaking class. Required physical education classes are usually unpopular, but most students spend much more time and energy in voluntary athletics. These facts point to the need for a complete re-orientation of the curriculum. The best knowledge is acquired joyfully, through cooperation with one's fellows and with guidance, rather than indoctrination, by superiors.

In many cases, the acquisition of a definite interest has been accompanied by vastly improved grades.

One college student, who had earned a C grade in his first semester physics course, became interested in radio. He learned so much about electricity from two weeks' intensive reading on radio that he made an A without particular effort the next semester.

The effectiveness of increased motivation was demonstrated in the same study of typesetters we mentioned earlier. Most of the typesetters had had many years of experience and should have been near their ultimate plateau or physiological limit. To measure the effect of increased motivation, they were allowed generous piece rates for all production over a figure based on 75 per cent of an expert's performance. The increase in production ranged from 59 to 105 per cent. [19]

This study and others suggest that steadily increasing incentives are necessary to improvement over a period of years. For example, many college graduates are offered positions with large industrial concerns upon graduation. Incentive to succeed in a beginning job is always considerable, and at first the salary, however small, seems adequate. If, however, these young people receive no increases in salary and responsibility after several years, there is an inevitable "slowing down" or loss of motivation. The high rate of turnover in the more routine jobs may thus be explained. Some employees, of course, reach the limits of their ability at an early age, but progressive corporations are reducing costly labor turnover by a policy of regular promotions to competent persons.

7. Effects of Practice

"Practice makes perfect" is one old proverb that is founded upon psychological truth. Generally the principle of frequency is sound. The more miles we have driven a car the more expert we become as drivers, the more pages we have typed the faster we become as typists, the more miles we have swum in the past the less fatigued we become from swimming now.

The principle has been widely applied in advertising and salesmanship. "Repetition is Reputation" is the motto of one advertising firm. It is assumed that the more times a statement is read or heard the greater acceptance it will enjoy. For instance, if a person asks for toothpaste in a drugstore and is shown several brands, he will usually choose one familiar to him through advertising. He has no assurance that the advertised brand is better, but the average citizen has neither the time nor the inclination to test scientifically each article he uses. The oftener a politician tells his constituents how benevolent and constructive his administration has been, the more chance he has of being re-elected. It is rarely necessary for him to introduce proof.

There are, however, several difficulties in connection with an unqualified acceptance of the principle of frequency. (1) To improve, a person must know what his present performance is. If you were blind-

folded, asked to shoot a rifle at an unseen target, and not told where your shots hit, you could not expect to become a better marksman. In one experiment the subject closed his eyes and drew lines of three, four, five, or six inches. He drew hundreds of lines each day for several days, but his accuracy was not measured until he had completed the tests. He not only failed to improve, but his later lines were as variable as the first. [32]

This experiment was later extended by blindfolding subjects and asking them to draw three-inch lines. [33] Some of them were not told how well they had done; others were told "right" or "wrong," based upon a tolerance of one-eighth of an inch; and still others were told the exact length of the line they had just drawn. The superiority of the latter technique was considerable. The second method produced more improvement than the first, although the subject did not know whether his original line was long or short.

In everyday life a person may improve by criticizing himself. Speakers learn more effective means of presentation; golfers and billiard players watch their shots and correct their errors. By a trial-and-error method the best system is retained.

There are several other exceptions to the principle of frequency. (2) If you do not pay attention and exert effort, learning may not occur. (3) If you are on a plateau or near your physiological limit, practice will not be effective. (4) Much learning occurs as a result of a single occurrence. Fears are often based upon one painful experience. Frequency is important chiefly in connection with routine learning like memory for telephone numbers, dates, chemical formulae, and skill in athletics and typing. (5) Extended practice may actually decrease skill. If a person plays tennis every day, he may lose zest for the game. Also, it is possible to practice errors so that, instead of improvement, deterioration of skill occurs. When a person falls into a bad habit, such as slicing drives in golf, it is often wise to refrain from practice for a while. A short layoff usually restores the correct act and allows the error to die out. Even though an act has been done incorrectly only a few times, its recency gives the erroneous habit temporary precedence.

Frequency is often employed by public speakers and by writers. In spite of the danger of boring an audience if an idea is mentioned more than once, reiteration is necessary if the idea is to be remembered. The clever speaker veils the idea in slightly different garb each time it is presented. For instance, how many of you remember that the IQ is more innate than acquired? If the statement had been made only once, few readers would have recalled the proper answer. But the innateness

of the IQ was stated, restated, evidence was weighed, and arguments of both sides were summarized.

8. Overlearning

Overlearning is an extension of the principle of frequency. If practice is continued beyond the point of bare learning, memory becomes much more persistent. Do you remember things you learned as a child—perhaps the prayer you said every night, the poem you often recited, or the rules of a club to which you belonged? Why do you remember these things, when topics you studied last night are already hazy in your memory? The prayer, the poem, and the club rules were overlearned; they were repeated so many times that they remained in your memory. A person who has ridden a bicycle or skated well can cease for years and he will suffer no perceptible diminution in skill.

How should one overlearn an act he wishes to do well? Several investigations of the subject suggest that the most effective procedure is to allow half as many additional repetitions as were originally required. [20] For instance, if you need twenty trials to learn a vocabulary, another ten repetitions may double the memory value. Further repetitions may help, but a point of diminishing returns soon occurs and extra time may not be spent profitably.

Different degrees of overlearning are advisable with different materials. Fifty per cent or less should be satisfactory for school assignments. Memorization of chemical formulae and foreign language vocabulary requires many more repetitions to insure permanence. Motor skills usually receive more practice than intellectual skills. After a person has learned to ride a bicycle, he usually insures permanent retention of the skill through constant riding.

Overlearning need not occur immediately after the original learning. In fact, it is preferable to rehearse material the next day, and thus receive the advantage of a distribution of learning. For instance, an assignment might be read during the evening and then reviewed briefly before class the next morning.

9. Effect and Vividness

The principles, or laws, of effect and vividness are largely parallel to each other; yet they do not harmonize perfectly. "Effect" is simply that a pleasant act will be stamped in and remembered, whereas an unpleasant experience prevents a memory association from being formed. Its corollary, vividness or intensity, postulates the persistence of emotionally toned experiences and the relatively poor memory value of those lacking in vividness. In both cases it is agreed that pleasantly

toned events are learned and retained, and that neutral happenings are neither learned nor retained well. The point under dispute is the memory value of unpleasant incidents.

Outstanding in the daily life histories of most people are such pleasant events as parties, trips, athletic contests, and such painful ones as illnesses and deaths. Your subsequent behavior may have been modified by some of them. Mistakes may be as important as successes in shaping a future course of action. But there is also the fact which we have mentioned previously (page 261), that in some instances of intense unpleasantness there may be a repression of the memories out of the conscious mind.

It has been demonstrated that both punishment and reward speed up the learning process. Eighty subjects learned a maze, forty with and forty without an electrical shock. [5] The averages are reproduced in Table 36.

TABLE 36
INFLUENCE OF ELECTRICAL SHOCKS UPON THE SPEED OF MAZE LEARNING

	Trials	Errors	Time
Control group	58	531	1752 (sec.)
Shocked group	21	254	1065 (sec.)
Gain	64%	52%	39%

Students who received shocks (by means of electrodes on the wrist) solved the maze in about half the time, but the time score was not reduced so much as that for trials and errors because the shocked group proceeded much more slowly and carefully. Subjects were requested to report the severity of the shock, and it appeared that those for whom the punishment was of moderate intensity received the greatest motivation. Those who did not mind the shock and those whom it pained severely gained less. In the latter case response was disorganized and motivation not increased. In another study, subjects were asked to guess the number associated with a certain letter, and incorrect answers were rewarded by a shock. In this test learning was accomplished with 14 per cent fewer trials and 20 per cent fewer mistakes. [6]

The law of effect has been studied by psychologists for several decades. [8] One of the important problems is: How do the pleasurable or painful consequences of an act cause it to be "stamped in" or to be discarded after the behavior has occurred? For example, why should a food reward at the end of a maze pathway enable a rat to traverse it more correctly on the next trial? Such speculations concern students of advanced psychology. For our present purposes, it is sufficient to

say that many experiments have shown that emotional tone does assist in learning.

Events that have important consequences are usually recalled vividly. People tend to reminisce about the last time they saw a recently deceased friend or about events leading up to a catastrophic occurrence. This newspaper account is an example of the working of intensity.

ELIZABETHTOWN, NEW YORK, Oct. 25, 1939.—The elderly white-haired mother of —— told a jury today that her son was at home in Syracuse, N. Y., the night he is accused of robbing a roadhouse of \$700 in 1930.

"He came in at midnight on Aug. 4 and went to bed," Mrs. —— testified.

He left home the following morning, taking his sister to work and telling his mother that he expected to play baseball. That was the last she saw of him, the mother testified, until he was arrested and returned several months ago. A second sister corroborated her mother's testimony.

Is testimony after such a long time likely to be accurate? Where were you on the night of August 4, 1930? This question is not at all fair, for the fact that we cannot recollect our whereabouts on that date does not prove that no one can. We learn that the defendant fled the next day. We can readily imagine that the mother thought about that occurrence and may have told friends what her son had done the last few hours or days he was at home. Since the whole episode was dramatic, and since the mother had not seen the son for a long time, she would remember the events of the last evening vividly. Thus, we can grant that the testimony was probably accurate. If, on the other hand, the son had not left until a month or two later, testimony concerning that particular night would have been virtually worthless.

10. Primacy and Recency: Order of Learning

Primacy and *recency* are simple principles capable of widespread application. The terms mean that the first and last acts of a sequence are the most likely to be learned, and that the earliest and latest events in point of time are best remembered.

In human maze learning, it has been discovered repeatedly that the first few and the last few turns are learned before those in the middle of the pattern. The same order of retention characterizes sections of a highway and advertisements within a magazine. If a person drives a number of times between New York and Philadelphia, he will first become familiar with the outskirts of both cities, and then gradually fill in his gaps of memory toward the midpoint. Similarly, in a magazine (ignoring front and back covers and other preferred locations)

the advertisements which appear toward the beginning and toward the end produce the best retention value. This principle assumes, of course, that other factors are equal. If one section of the highway or one advertisement is unusual in some way, the contrast may be sufficient to overcome the factor of position.

These principles apply to time as well as to space. First impressions of a person, favorable or unfavorable, are likely to persist. An important principle of learning is that one should begin a certain activity by doing it correctly. One should learn to type, swim, play tennis, drive a car, or pronounce French words in the correct way. Faulty habits learned in the first few practice sessions are extremely difficult to overcome.

A slight variation in the advantages of firstness and lastness was seen in a recent test. [21] The investigator called the roll alphabetically in two classes, sized 106 and 60, three times a week for fifteen weeks. Without advance notice he then asked the students to write the list of members of the class in proper order so far as possible. To give a little aid the instructor read the name of the first individual and the class was given five seconds to recall that of individual B; then his name was given, and five seconds were allowed to recall C's name, and so on. It was found that two-thirds of the students remembered the name of the person preceding him, but less than half recalled names coming two to six places earlier. Memory for names appearing after a student's own dropped off even more rapidly. Students apparently relaxed and paid less attention after the "goal"—their own name—had been reached. Thus, proximity in time is seen to be an important factor.

Recency is responsible for a great many errors. I recently typed "praised" as "priased" the first time on a certain afternoon, and then proceeded to write it that way half a dozen times. When a diver is executing a particular dive very badly, he stops practice for the day. Continued practice may only "stamp in" the bad habit, while if a person desists temporarily, he recovers customary skill, since he has done the correct act many times (frequency) and can easily overcome the temporary recency disadvantage. In some instances the correct and desired habit may be restored by slow and deliberate attention. In the instance of misspelling mentioned above, I regained my correct spelling of "praised" by typing it extremely slowly, letter by letter, the next few times I had occasion to write it.

The principles of primacy and recency may be used deliberately by writers and speakers. The most important points should be made first and last—if there is just one major point, give it double emphasis by stating it one way at the beginning and in slightly altered form at

the conclusion. The development of the argument and quoting of illustrations should occupy the less favorable central spots.

11. Time Intervals in the Formation of Associations

The "law of contiguity" has been stated thus: [27] "The fact that two psychological processes occur together in time or in immediate succession increases the probability that an associative connection between them will develop."

We may illustrate this law by an extreme example. Suppose you were suddenly placed among a people whose language was totally unfamiliar to you. You would be forced to learn words by associating sounds with objects and actions. If the chieftain held up a teakettle and said "gup," you could form that association. If he threw a stone and said "wam balu" and then threw a stick and said "wam tik," you would deduce that "wam" meant to throw and that "balu" and "tik" were symbols for stone and stick, respectively. But the crucial thing for learning is that the sound and the action would have to occur in close proximity. If the chief displayed a teakettle and hours later said "gup" you could not reasonably be expected to associate the two.

In a simple form the principle of contiguity may be measured with extreme accuracy. The conditioned reflex procedure was used to measure the degree of association produced by various time intervals between the original and substitute stimuli. It was found that the optimal interval occurred when the sound preceded the electric shock (original stimulus) by half a second. [35] The link was weaker when the time intervals were one-quarter or three-quarters of a second. Although in this form of association the time interval is an extremely critical thing, in a more complex situation time sequences could not be ascertained with such precision. Food is generally given to an animal when he finishes the maze or solves the problem, but suppose it is not given for a minute or for five minutes? Will the incentive diminish, with consequent retardation of learning? Experiments have not shown any pronounced trends, but it is likely that longer delays materially affect efficiency of learning. [34] With higher species it is probable that the reward and the act do not have to be linked so closely. The monkey appears to solve problems for the sheer joy of doing so. The college student will work in a laboratory for no reward other than his instructor's thanks or the satisfaction of his intellectual curiosity.

The principle of proximity for the formation of associations operates in punishment for misbehavior or for crime. The punishment need not be severe, but it should occur so closely in point of time to the undesired act that the culprit will form an association between the be-

havior and the unpleasant consequences. If a child misbehaves in the forenoon and is told to "wait until Daddy gets home," he will probably have forgotten all about the misbehavior when the punishment actually materializes. With criminals, long delays before arrest, release on bail before trial, continuances and appeals often produce a delay of as much as two years between the offense and commencement of serving the sentence. Thus, punishment loses much of its deterrent effect.

12. Meaning as an Aid to Learning

A student who kept a record in his German dictionary of every word he looked up found upon later inspection that some words had been looked up as many as ten times and others had been learned from only one consultation of the dictionary.

Why is there such a difference in difficulty (or ease) of learning? It depends upon the degree of meaning attached to the two things to be associated. One remembers that oysters should not be eaten in months without an "r." It is easy to remember that the French word for white is "blanc" when it is associated with "blanch," meaning to turn white, as in fear. The hardest words to learn are those for which there are no exact equivalents in one's own language. An example is the German "gemütlich," which a dictionary defines as good-natured or kindly, yet it has further shades of meaning which cannot be expressed in a single word.

Whether it is entirely true that no association is possible if meaning is utterly absent is doubtful. But certainly meaning contributes greatly to rapidity of learning and permanence of retention. We made a study of this by asking a hundred students to learn the following Hindu-English vocabulary list: [13]

Jild	=	Book
Sard	=	Cold
Jora	=	Mate
Kund	=	Pool
Narm	=	Soft
Bosa	=	Kiss
Poti	=	Bulb
Ajib	=	Rare
Sisa	=	Lead
Umda	=	Nice
Balu	=	Sand ¹

¹Husband, R. W. Intercorrelations among learning abilities: *I. J. genet. Psychol.*, 1939, 55, 353-364.

In addition to measuring the time required for learning, the subjects were asked to tell what associations, if any, had facilitated their learning. A few examples are quoted. "Poli" was the easiest word to learn, since it suggested a flower "pot," which holds the bulb. "Bosa" has an "s" sound, which suggests "kiss." "Umda" contains an "m-m-m" sound, often hummed to indicate satisfaction, hence "nice." "Kund" produced an interesting source of interference, as it rhymed with "pond," not "pool." One student associated balu-sand, because it reminded him of the popular song, "On the Beach at Bali-Bali." "Ajib" and "Jora" uniformly gave difficulty, for there were no apparent associations.

Certain numbers contain meaning and are remembered more easily than others. Large stores and office buildings often have telephone numbers divisible by a hundred or a thousand. A street address such as 1122 has definite mnemonic value. The height of Fujiyama is easily remembered as 12,365 feet when one notices that it is composed of the number of months and the number of days in a year.

The utilization of meaning is extremely valuable in education, particularly if one desires to remember the material after the course has been completed. Geography and history mean much more if the student has visited the places concerned. Students in botany and geology courses are taken on field trips, so that material studied abstractly will gain concrete meaning. Seeing cases of disease in clinics has more meaning for medical students than any amount of textbook study. The citation of examples is an invaluable aid to memory. Can't you remember "rationalization" better because a few instances were quoted than if discussion had been restricted to a mere formal definition?

13. Active and Passive Learning: Recitation

A striking psychological experiment was conducted by Gates on recitation versus passive reading. [9] Giving school children in the fourth, sixth, and eighth grades nine minutes to work, he tried various combinations of study and recitation. For nonsense material, it was actually found that 10 per cent of the nine minutes spent in passive study and 90 per cent spent reciting—pupils were permitted to glance at the page when stuck—produced the best memory. In the case of meaningful material (biographical sketches) a 20:80 ratio proved optimal. Those in the lower grades profited more from recitation than did older pupils. Possibly the advantage of recitation would be even further reduced for college students, but it is still undeniably of great service.

There are three chief reasons why recitation is profitable. First, it is

active rather than passive. If a person merely reads his attention may wander, but if he recites he must concentrate. Second, recitation gives a clear check on errors or gaps which might otherwise remain undetected. Third, recitation affords practice in reproducing the material in a way that may be useful later, say on examinations. These results suggest that serious students might improve their learning in the privacy of their rooms by answering possible questions vocally, by writing lists or formulae, and by reading a difficult section aloud instead of silently.

This principle also demonstrates the value of taking notes at lectures and while reading. Even if the notes are never referred to, they are beneficial merely because they have required active concentration. The same thing applies to outlines and summaries of courses, such as are often prepared in advance of final examinations. After an outline has been prepared, the student finds that he has remembered much of the study material.

Recitation discloses gaps in information and vagueness of statement. Since it is at least partially true that you do not know a thing unless you can state it clearly, the value of spoken and written recitation is evident. Modern educational philosophy stresses the group discussion-recitation technique. Naturally, colleges with small student bodies and relatively large faculties are better able to adopt this method than are state universities with their huge classes. Initiative and critical thinking are not encouraged in large lecture halls where hundreds of students passively sit, take notes, or look out the window while chewing gum in the mildly ruminative manner of a cow.

14. Learn by Wholes Rather Than by Parts

In learning a passage of prose or poetry the typical procedure is to learn the first line, then the second, and so on. Finally the lines are combined and the passage is recited as a whole. This hit-or-miss method involves a good deal of waste. A better method is to read the whole passage, and re-read it (preferably aloud) until the selection is learned. This is the "whole-learning" method. While it is possible that the advantages of the method have been overemphasized by some writers, it has the undeniable merit that each part of a passage receives equal practice.

Instead of overlearning the first few lines and acquiring the remainder in sketchy fashion, the associations in whole-learning are all in the proper forward direction and meaning is added with each succeeding passage. Of course, in part-learning one derives encouragement

from immediate progress—the same satisfaction one has in completing one section of a lawn in mowing—a favorable factor that is considerably delayed in the other method.

There have been too few experiments in whole-learning upon which to base conclusions, but tentatively we can say that: [23] Whole-learning in general seems better than part; the advantage is greater with meaningful than with rote materials; brighter and older students do better with whole-learning, duller and younger children often use the part method to better advantage; [22] since the part method seems more natural, some practice may be necessary to demonstrate the advantage of the whole method; investigators are doubtful that very long passages may be learned as advantageously by the whole method, but in one case a poem of 240 lines was best learned this way. [26] Since the materials studied by college students are meaningful in nature, the author suggests that his readers test for themselves the feasibility of whole-learning. The method has been successfully practiced by persons of mature intellect, and they have found it a more efficient way of learning.

In several instances, a combination of methods, called the *progressive pari* method, has proved efficacious. According to this method the student learns Section I, then Section II, then I and II together. Next III will be assimilated and rehearsed with I and II. Section IV is then added, and so on.

A common and serious fault in learning is "cramming." This practice may enable one to pass a course but it has poor memory value. The fact was demonstrated by an experiment in which subjects read a technical passage five times, one group immediately and the other group once a day for five days. A test given immediately after the final reading revealed a 4 per cent superiority for the "distributed" group, but two weeks later their superiority had jumped to 20 per cent, and at the end of a month to 25 per cent. [1]

The effectiveness of correct learning methods is demonstrated by length of memory, rather than by immediate recall. [30] Usually, materials that are acquired rapidly are retained only for a brief period, and then vanish from the memory altogether. A week after final examinations many students would fall considerably below their original performance.

Loss of memory has been explained physiologically as follows: Residual activity in the nervous system occurring *after* direct contact with intellectual material has ceased aids in memory fixation. When, however, the intellectual material is absorbed in large quantity over a short period of time, residual activity is not efficient. We shall again

consider this subject under the heading of Retroactive Inhibition in the next chapter.

15. Individual Differences in Learning Rates

AGE DIFFERENCES. Age differences in learning ability are not so great as is popularly supposed. The proverb, "You can't teach an old dog new tricks," is not altogether true when applied to human beings.

Several investigations of learning ability at various ages have been made, with the general trend of results as follows: [28] (1) Learning ability increases up to twenty. (2) From twenty to fifty it remains roughly constant. (3) After fifty or fifty-five the speed of learning becomes slower. (4) Decline in learning ability after fifty is more serious for rote material than for materials to which experience and meaningful interpretations can be applied. [12] An elderly lawyer, for instance, might learn some new branch of law without difficulty, but he might have trouble in acquiring a foreign language or skill in carpentry. (5) People who have kept in practice by engaging in scholarly occupations, reading books of a stimulating nature or attending summer school, show a slower decline.

SEX DIFFERENCES. Sex differences in learning are only slight. The consistent trends are the same as those which exist in subtests on an intelligence examination. Women are rather better than men in rote learning, such as shorthand characters or foreign language vocabulary. Men appear to be slightly superior in learning meaningful material, especially when reasoning is demanded. Men also excel, although slightly again, in sciences. Interest and training may be responsible for the latter difference.

INTELLIGENCE AND SPEED OF LEARNING. One might expect a high degree of correlation between these two functions but, strangely enough, the coefficients are generally only moderate. Part of this lack of agreement may be due to a statistical technicality. The subjects in most of the studies in this area were college students, which suggests a rather narrow range of talent and the same general ability level. Within such homogeneous groups comparatively minor extraneous factors, such as health or motivation, may cause relative position to shift widely. When groups of widely disparate abilities are tested, there is a higher correlation. Further, many of the learning tests used in the laboratory are quite simple. It was found that tests requiring complex ideational learning gave a higher correlation with intelligence. Motor abilities correlate almost zero with abstract, as we learned in our discussion of

Special Abilities in Chapter XV. Finally, since intelligence itself is a composite of performances on half a dozen different types of items, no one of which correlates more than moderately with the total score, we should not expect a single learning score to correlate highly with intelligence. Actual coefficients vary considerably, but the median figure does not rise above $+ .20$. There are certain group trends, however. Brighter students, *taken as a group*, average faster in learning, although there are many individual exceptions. One reason for their superiority is that they devise more efficient methods of learning.

PHENOMENAL MEMORIZING. This topic is closely allied to that of the Idiot Savant (page 330). We noted that people with relatively mediocre general ability occasionally demonstrate remarkable talents along a single line. This factor applies to learning as well as to intelligence.

One of the most remarkable of these is the achievement of the "Shass Pollak," a group of Polish students of the Talmud. They memorized the Talmud so well that they were able, rapidly and accurately, to name the exact word on each page which was printed beneath a designated word. Although this appears to be an extraordinary feat, the men were not talented nor did many of them understand the underlying philosophy of the book. In memorization they were immensely assisted by the fact that the Babylonian Talmud was printed with exactly the same pagination and arrangement of words on each page.

It may be that some people have an unusual talent for memorization. As a general rule, however, these special gifts may be attributed to experience, constant practice, and environmental pressure. Stock company actors, for example, can pick up parts quite rapidly. They have had a great deal of practice in memorization and are trained to "ad lib" when at loss for the exact speech.

THE EFFECTS OF PRACTICE UPON RELATIVE POSITION WITHIN THE GROUP. This problem is parallel to that of constancy of the IQ. Is a person's skill during the first few practice sessions indicative of his ultimate level of performance? If this were true, it would have considerable practical value in selecting typists or factory workers. If those who did well at first were always at the top six months later, we would have an accurate early means of prediction and selection. If there were no correlation, we would have to postpone final selection until each person had arrived at a point near his physiological limit or had attained a satisfactory level of performance for that occupation.

In answer to this question it has been found that rank order remains fairly constant. Those who take the lead at the beginning of practice are usually near the top later. The most thorough study of this problem

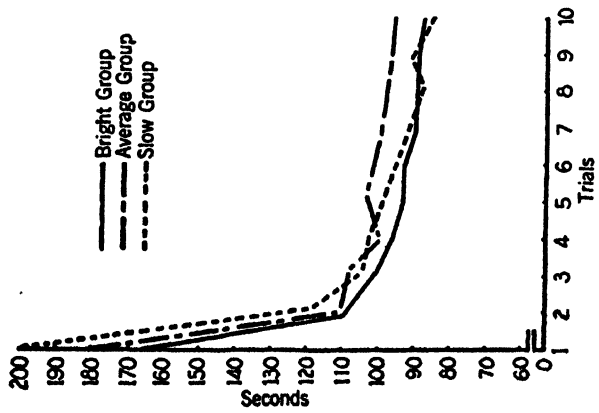

In a simple learning task, learners of different abilities come closer together. In this case the task is card sorting. At the beginning the differences are three times as large as at the end of ten trials.

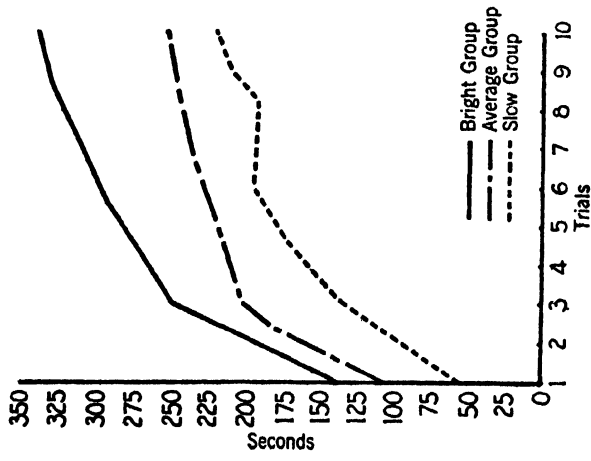

In code substitution, involving somewhat more difficult functions, differences hold more even.

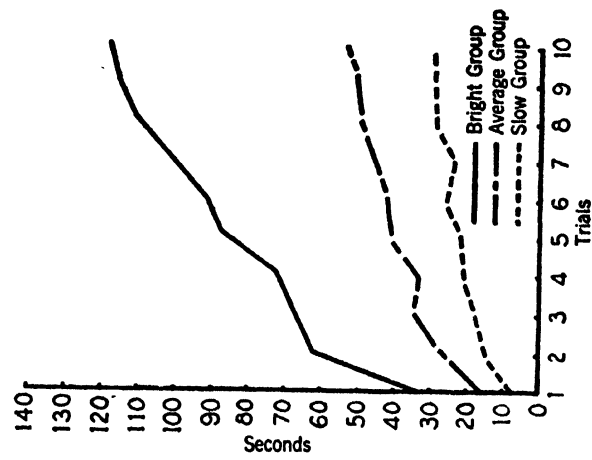

But in complex tasks, as in this test of speed of solution of fairly difficult algebraic problems, the bright groups not only start at a higher point, but gain from then on over the less well-endowed pupils.

FIG. 49.—Spread of Abilities with Practice.

used high school children on three different tests: card sorting, code substitution, and solution of algebraic problems. [29] Although in each case rank orders remained approximately the same, different trends appeared with tests of different degrees of difficulty. These trends are shown in the three charts of Fig. 49. In the simple task of sorting cards into suits, differences narrowed as practice went on. In code substitution, a problem of medium difficulty, the separation of the groups remained about constant. But in the most difficult test, solution of complex algebraic problems, the students who were better originally not only maintained leadership, but at the end of the training period excelled by a much greater margin than before.

These findings are verified in terms of educational progress over a number of years. In the first grade, material is of such simplicity that dullards do reasonably well. But in the higher grades, marginal pupils fall by the wayside, regardless of the effort they put forth, while the brighter students continue to earn high grades. Business success follows the same trend. Those who earn but slightly more than their associates at the age of twenty-five can expect to receive double or triple the income of their less gifted friends at the age of fifty.

INTERCORRELATIONS AMONG LEARNING ABILITIES. This problem is similar to one we discussed in connection with intelligence. Are the various learning abilities on the same level, or does a person have a high degree of ability to learn one type of material and a lower degree in other fields? The author attacked this problem by requiring a hundred college students to go through seventeen different tests of learning and memory. [13] The tests were given in three one-hour periods, separated by a week's interval after each. The tests were chosen to represent a wide variety of learning situations: simple motor tests of speed and accuracy of muscular coordination, tests of vocabulary learning, cancellation tests, and tests for ideational memory of prose passages. Among these tests a total of 91 intercorrelations were computed, with a surprisingly low median of $+.13$. Only a third of all the coefficients rose above $+.20$. Close analysis of the figures showed that tests of similar nature produced higher relationships. The highest single figure was the correlation between learning Persian-English associates presented in visual form and Hindu-English associates presented orally. Even this figure was not especially convincing: $+.53$.

Hence we conclude that learning differs from intelligence. Intelligence, as we have seen, is largely a general function or ability and is roughly equal in various fields of endeavor. In learning, however, we must speak of abilities in the plural, since ability to learn varies with the material used. We cannot describe a person as a rapid or a slow

learner; rather, we must specify the type of material he learns quickly or slowly.

16. Transfer of Training

(A) PROBLEMS. Does training in one kind of work produce improvement in other functions? A satisfactory answer to that question would be of immense importance to education. In the United States almost everybody is urged to go to school "to prepare for life," and most of our educational practices are based upon the assumption that transfer of method and learning takes place between school and occupational life. Within the educational system itself, certain prep or high school courses are required for college entrance, certain subjects are necessary to secure a college diploma, and certain groups of courses are needed for a major in a department of study. These prerequisites are based upon two assumptions: they form a foundation for advanced studies and they are essential to the development of a well-rounded personality.

Pressey has stated these problems of transfer in a number of searching questions. [25]

To what extent and in what way will the acquirement of skill, understanding, and attitude in one subject or topic or in one type of situation influence skill, knowledge, understanding, and attitude in another subject or topic or in a very different situation?

Do these subjects [Latin and mathematics] have a peculiar potency for developing in a pupil habits of attention, acuity in discrimination, and consistency of thinking, so that as a result of the study of these disciplines the individual will deal with any intellectual problem more efficiently than if he had spent his time on other subjects in the curriculum?

For instance, to what extent does the study of Latin increase English vocabulary, facilitate the learning of French grammar, or foster interest in ancient history?

Does the usual high school course in chemistry contribute to the average girl's understanding of cooking or household arts? Does a course in American history or community civics make the student shrewder in his appraisal of local government or wiser in voting?²

The problem of transfer has two practical aspects. How much transfer occurs between one school subject and another, and how much between school subjects and vocational and daily life problems? Certain subjects in the school curriculum have been justified because they are

²Pressey, S. L. *Psychology and the New Education*. New York: Harper and Bros., 1933.

supposed to train certain of the mental faculties. Arithmetic and Latin, for example, have been justified in somewhat the following terms:

Arithmetic forms in the pupil habits of mental attention, argumentative sequence, accuracy, and satisfaction in truth. These habits do not seem to spring equally from the study of any other subject suitable to elementary instruction.

Latin was justified in much the same way, long after the language had ceased to be one in which scholarly books were written. Since it is a highly declined and exact language, it is said to develop precision and linguistic skill and to aid the student in his use of English.⁹

(B) THEORIES OF TRANSFER. In the last decade or two, scholars have become more skeptical of the validity of established customs. They have noted that some well-educated people are not really prepared to face everyday problems, that people eminent in one field think as carelessly as untrained laymen outside that field, and that many others are successful because of high native ability rather than formal education. All these discoveries have made schoolmen less convinced of the eternal and unchangeable virtues of the college curriculum or, for that matter, the elementary and secondary school courses of study.

If it is true that the study of foreign languages assists the student with his own, we should discover how this transfer takes place. There is obviously some transfer, since a person trained in the classics can deduce the meanings of certain English words through an examination of their roots. But, someone might ask, is it better to study the Latin and Greek or to consult a good dictionary occasionally? In other words, might it not be more beneficial to study the subject itself than to learn something else in the hope that indirect benefits will accrue? In athletics, a boy would not train for football by playing basketball. The only possible gain would be in physical conditioning; no transfer of skill would occur.

There are two main theories about transfer: it is proportional to the number of elements of the first situation that can be applied to the second; it consists of learning methods of work, that is, how an act is performed.

(1) *Identical elements.* [10] We have seen that Latin is of assistance chiefly in comprehension of words of Latin root, but that it helps to develop general linguistic ability to a small extent. [25] Practice in arithmetic also aids only in the functions studied, and not in others to any appreciable extent.

On the same basis, how can we explain the "all-round athlete," the

⁹*Ibid.*

man who does well in several sports? Of course, good muscular coordination can be applied to any sport. Except for this, however, ability in one sport assists the athlete in a new sport only to the extent that he can transfer his skills. Since both basketball and tennis involve chasing a ball and judging its speed, a transfer often occurs. But basketball experience will not help in skating, because the two sports involve entirely different functions. More transfer would occur between tennis and ping-pong or between ice and roller skating. Where conditions are identical, there is no real transfer. For instance, when a growing child graduates from a tricycle to a bicycle, he uses the same rotary pedaling movements and he usually adapts himself more rapidly than a child who has never ridden a tricycle.

There may actually be cases of negative transfer. Some baseball coaches forbid their players to play golf on the theory that batting skill may be impaired by the difference in swing.

"Identical elements" as an aspect of transfer may include the environment as well as the act itself. [16] If one is practicing a speech, he should stand up and declaim it in a loud voice. If he can use an auditorium, so much the better. Students usually do better in examinations that are held in the same room in which the class meets.

(2) *Methods*. Skills are transferable when elements applying to two different situations overlap. If a student becomes proficient in setting up equipment in the chemistry laboratory, he will be better able to perform a similar task in physics. He has learned *how to go about the task* through the application of a general principle. Students of advanced psychology adapt themselves much more quickly to novel problems than do beginning students who have not participated in experiments.

We quote results of an experiment in methods of transfer. [18]

Two groups of pupils in the fifth and sixth grades were required to hit with a small dart a target which was placed under water. The difficulty of hitting the target arises, of course, from the deflection which the light suffers thru diffraction. . . . In this experiment one group of boys was left to work out experience without theoretical training. These two groups began practice with the target under twelve inches of water. It is a very striking fact that in the first series of trials the boys who knew the theory of refraction and those who did not gave about the same results. That is, theory seemed to be of no value in the first tests. All the boys had to learn how to use the dart, and theory proved to be no substitute for practice. At this point the conditions were changed. The twelve inches of water were reduced to four. The difference between the two groups of boys now came out very strikingly. The boys without theory were very much confused. The practise gained with twelve inches of water did not help them with four

inches. Their errors were large and persistent. On the other hand, the boys who had the theory fitted themselves to four inches very rapidly. Their theory evidently helped them to see the reason why they must not apply the twelve-inch habit to four inches of water.*

(C) RECOMMENDATIONS. No matter which of the theories were later proved to be correct, our conclusions and the suggestions based upon them would be the same. Transfer is very narrow in scope. It is better to learn the act itself than an apparently related skill. If one wishes to improve his English vocabulary, vocabulary is the thing to study. If he wishes to read French, he should concentrate on French. If he plans a trip to France and wants to be able to speak the language, he should take lessons in French conversation and practice speaking French aloud, not merely read it. If a girl wants to learn to cook, she should study cooking, not dietetics. A laboratory course in chemistry of foods will be helpful to her if she becomes a dietitian, but it will not help her with the art of cookery itself.

In case a particular function cannot be practiced, a skill that has many elements in common with the desired skill should be learned. A person cannot swim in the winter (outdoors) nor can he usually skate in the summer, but if he wishes to keep in good condition, he can practice exercises that involve the same muscles. Roller skating, thus, is better than running as a preparation for ice skating.

In connection with school curriculum, teachers should use examples and illustrations pertinent to the past experiences and future ambitions of their students. If law students wish to know how the principles of memory apply to reliability of testimony, the principles should be discussed in terms of that type of situation.

17. Which Principles of Learning Are Most Important?

At this point the reader may be asking himself which of the principles of learning we have given are most important to him. This question cannot be answered in a sentence, since different situations require different techniques of learning.

However, in an interesting study Jersild evaluated some of the more common principles. [17] A brief fictitious biography of a famous man was read to a class as an orator might deliver it before a great throng. Frequency was given a certain item by repeating the same point several times. Vividness was introduced by means of gestures, banging the desk, speaking loudly, deliberately, and with feeling, and by long

*Judd, D. H. The relation of special training to general intelligence. *Educ. Rev.*, 1908, 36, 28-42.

pauses in the delivery. Primacy and recency were measured by recalling items in various positions within the passage.

Results of the experiment are quoted in percentage form in Table 37. "Middle neutral" was given an arbitrary value of 100, since this phrase denoted statements not favored in any way by frequency, intensity, or position.

Since this study was conducted in a classroom under special conditions, it is unwise to generalize broadly upon its results, but it offers several suggestions and compares, at least in a crude manner, the laws of learning. Of course, the typical audience attends voluntarily and once only, and it does not ordinarily hear a passage broken up in an artificial manner in order that its impact may be studied.

TABLE 37

ORDER-OF-MERIT ARRANGEMENT OF THE VARIOUS DEGREES AND FORMS OF PRIMACY, RECENCY, FREQUENCY, AND VIVIDNESS

DEVICE	PERCENTAGE SCORE
5 repetitions	315
4 repetitions	246
3 repetitions	197
"Now get this" (Vividness)	191
Primacy; first degree (very first)	175
2 distributed repetitions, 11th and 60th	167
Primacy; second degree (second in order)	163
2 distributed repetitions; 35th and 40th	162
"Did you notice that?"	154
Pause (Vividness)	143
2 concentrated repetitions; 60th, repeated	139
Primacy; 3rd position	135
Recency, last statement	128
Loudness	126
Recency, third from last	123
Recency, second from last	119
Gesture	118
2 concentrated repetitions, 10th, repeated	116
Bang	115
Middle neutral	100
Slowness	79

In Table 37 repetition leads the list of attention-getting qualities. The first statement (primacy) has a value of 175; in other words, it received only a few percentage points less than three repetitions in various intermediate positions. The beginning positions are much more effective than the final one; even the third position, as well as first and second, ranks higher in effectiveness (135) than the very last one (128). Also, widely separated repetitive statements are better remembered (167) than are ones which come close together (162, 139, and

116). Finally, some of the more common oratorical tricks, bellowing (126), gestures (118), banging (115), and slow speaking presumably for emphasis (79), produced comparatively poor memory value. Finally, it may be noted that calling attention to a point before it is made produced better memory than making its importance known after it had been uttered (191 to 154).

There is an anecdote about Paderewski which illustrates several laws: frequency, overlearning, review, and possibly recency. A questioner asked the famous pianist if he had to practice at all any more. Paderewski replied: "If I missed one day I would notice the difference: if I missed two days critics would notice it, and the third day it would be apparent to the audience."

REFERENCES

1. Austin, S. D. M. A study in logical memory. *Amer. J. Psychol.*, 1921, **32**, 370-403.
2. Bills, A. G. General experimental psychology. New York: Longmans, Green & Co., 1934. Pp. 202-203.
3. Book, W. F. Economy and technique of learning. Boston: D. C. Heath & Co., 1932.
4. Bryan, W. L., & Harter, N. Studies in the physiology and psychology of the telegraphic language. *Psychol. Rev.*, 1897, **4**, 27-53.
5. Bunch, M. E. The effect of electric shock as punishment for errors in human maze learning. *J. comp. Psychol.*, 1928, **8**, 343-359.
6. Bunch, M. E., & Hagman, E. P. The influence of electric shocks for errors in rational learning. *J. exp. Psychol.*, 1937, **21**, 330-341.
7. Cason, H. The conditioned pupillary reaction. *J. exp. Psychol.*, 1922, **5**, 108-146. The conditioned eyelid reaction. *J. exp. Psychol.*, 1922, **5**, 153-196.
8. Cason, H. The pleasure-pain theory of learning. *Psychol. Rev.*, 1932, **39**, 440-466.
9. Gates, A. I. Recitation as a factor in memorizing. *Arch. Psychol.*, 1917, **6**, No. 40.
10. Hunter, W. S. Experimental studies of learning. Chap. 15 in *Foundations of Experimental Psychology*, C. Murchison, editor. Worcester, Mass.: Clark Univ. Press, 1929.
11. Husband, R. W. Analysis of methods in human maze learning. *J. genet. Psychol.*, 1931, **39**, 258-278.
12. Husband, R. W. Certain age effects on maze performance. *J. genet. Psychol.*, 1930, **37**, 325-328.
13. Husband, R. W. Intercorrelations among learning abilities: I. *J. genet. Psychol.*, 1939, **55**, 353-364.
14. Husband, R. W., & Ludden, M. J. Sex differences in motor skills. *J. exp. Psychol.*, 1931, **14**, 414-422.

15. Huxley, A. Brave new world. New York: Doubleday, Doran & Co., 1932. Pp. 54 and 110.
16. James, Wm. Psychology, briefer course. New York: Henry Holt & Co., 1932.
17. Jersild, A. T. Primacy, recency, frequency, and vividness. *J. exp. Psychol.*, 1929, **12**, 58-70.
18. Judd, C. H. The relation of special training to general intelligence. *Educ. Rev.*, 1908, **36**, 28-42.
19. Kitson, H. D. A study of the output of workers under a particular wage incentive. *Univ. J. Bus.*, 1922, **1**, 54-68. Quoted from Young, P. T. *Motivation of Behavior*. New York: John Wiley & Sons, 1936.
20. Krueger, W. C. F. Further studies in overlearning. *J. exp. Psychol.*, 1930, **13**, 152-163.
21. Lepley, W. M. A gradient in incidental learning. *J. exp. Psychol.*, 1935, **18**, 195-201.
22. McGeoch, G. O. The intelligence quotient as a factor in the whole-part problem. *J. exp. Psychol.*, 1931, **14**, 333-358.
23. McGeoch, G. O. Whole-part problem. *Psychol. Bull.*, 1931, **28**, 713-739.
24. Pavlov, I. P. *Conditioned reflexes*. New York: Oxford Univ. Press, 1927.
25. Pressey, S. L. *Psychology and the new education*. New York: Harper & Bros., 1933.
26. Pyle, W. H. *The psychology of learning*. Baltimore: Warwick and York, 1928.
27. Robinson, E. S. *Association theory today*. New York: D. Appleton-Century Co., 1932.
28. Ruch, F. L. Adult learning. *Psychol. Bull.*, 1933, **30**, 387-414.
29. Ruch, G. M. The influence of the factor of intelligence on the form of the learning curve. *Psychol. Monogr.*, 1925, **34**, No. 160.
30. Ruch, T. C. Factors influencing the relative economy of massed and distributed practice in learning. *Psychol. Rev.*, 1928, **35**, 19-45.
31. Stratton, G. M. The mnemonic feat of the "Shass Pollak." *Psychol. Rev.*, 1917, **24**, 244-247.
32. Thorndike, E. L. The law of effect. *Amer. J. Psychol.*, 1927, **39**, 212-222.
33. Trowbridge, M. H., & Cason, H. An experimental study of Thorndike's theory of learning. *J. gen. Psychol.*, 1932, **7**, 245-260.
34. Warden, C. J., & Diamond, S. A preliminary study of the effect of delayed punishment on learning in the white rat. *J. genet. Psychol.*, 1931, **39**, 455-462.
35. Wolfe, H. M. Time factors in conditioning finger-withdrawal. *J. gen. Psychol.*, 1930, **4**, 372-378.

XX

MEMORY AND FORGETTING

I. RETENTION

1. The Nature of Memory

(A) TERMS. Learning, memory, and forgetting are three aspects of a single total process. Briefly, *learning* refers to the acquiring or up-building phase, that is, the period during which knowledge or skill is increasing. *Memory* (or *retention*) identifies the process of holding on to that which has already been learned. *Forgetting* is the partial or complete loss of material learned at a previous time. [7, 11, 21]

Memory may occur either through recall or recognition. *Recall* is the process of bringing material back into the consciousness by a voluntary act of will. *Recognition* involves familiarity with a certain stimulus or situation. Thus, if I ask you the name of a passer-by and you reply, "Stanley Jones," you are recalling. But if you cannot remember his name, and I ask, "Is he Stanley Jones?" and you reply, "Oh, yes, it was right on the tip of my tongue," you are demonstrating recognition. Examination questions may be framed to test either recall or recognition. Here is one of each type.

Recall: What are the functions of the frontal lobe?

Recognition: Check the functions of the frontal lobe.

- () Pain sensitivity;
- (✓) Motor coordination;
- () Visual associations;
- (✓) Motor speech;
- (✓) Higher mental processes.

In the latter question aid is given in the form of reminders. Hence recognition is easier than unaided recall.

(B) **CHARACTERISTICS OF MEMORY.** Learning and memory are inseparable. When we emphasize the importance of learning, we really mean that a vast fund of memories is necessary for efficient living. If, because you have driven many thousand miles, you drive an automobile without deliberate attention, you have overlearned that act to the point where you make proper choices in all situations without conscious and thoughtful decision. Habit makes possible the discharge of routine acts while we concentrate on more important problems. A day's activities may be planned while dressing and shaving; a business deal may be settled while eating lunch. Without memory, one would have to concentrate on each task and to do one thing at a time.

Redintegration may be described as the arousal of a whole network of memories by a fraction of the original stimuli. Thus an odor, a voice, a picture, a melody, may remind one of a multitude of things about a certain event. The scent of pine, for instance, serves to recall a whole summer vacation. A few faded photographs often bring back a great store of partially forgotten memories. The not uncommon feeling of familiarity surrounding a strange place or a new face may be explained on the basis of redintegration. Something about the scenery or the person stirs up unconscious associations, and if these are analyzed they may lead to a solution of the familiarity. Redintegration is strongly present in emotions. For instance, when one cheers madly at a parade, hisses an unpopular character in a movie, or distrusts a person because of his appearance, this phenomenon of memory is present.

Redintegration is not only an interesting observation about one of the workings of the mind; it also has practical uses. Police often utilize it in trying to revive the waning memories of a witness. They escort the witness to the original scenes and sometimes re-enact the crime with many of the original characters and much of the original action duplicated. Under these circumstances certain elusive memories may be brought back.

2. Curves of Forgetting

We all forget more and more as time goes on, but how much do we forget? How much is forgotten in a week, in a month, in a year?

RATE OF FORGETTING. Forgetting curves are not precisely similar, but there is one consistent trend. [3] The greatest loss occurs soon after the original learning, then the loss becomes smaller and smaller, and material that is remembered after several months remains almost indefinitely. It is probable that the less well learned and the less meaningful elements are the first to be lost. In Fig. 50 we reproduce several curves of retention. [40]

A general trend is exhibited in each of them. The curve for college botany conforms more closely to the shape generally considered typical of forgetting. We also see that degrees of retention vary from subject to subject. For instance, after eighteen months psychology shows twice the retention of botany. The loss in botany is truly appalling; it may be that there is too much emphasis upon terms and technicalities and not enough upon meaningful understanding of the entire plant or flower.

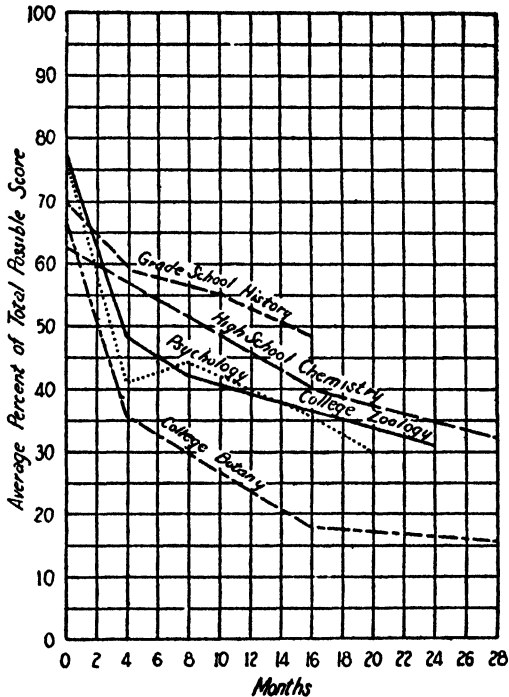

FIG. 50.—Curves of Retention for Various School Subjects.

The amount of contents lost is truly amazing. The curves strongly suggest more appropriate methods and contents of instruction.

INFLUENCE OF TYPE OF MATERIAL. Most learning falls into one of three classes: motor habits, rote facts, and logical information. The rate of forgetting varies considerably for these three classes of learning. [25] The general shape of the curve—dropping steeply at first and then less rapidly—is consistent; the differences are in the proportions. Rote facts (dates, technical terms, figures) are lost most rapidly. Logical memories and motor habits persist longer. In meaningful material the drop may be very slight over a considerable period of time.

OVERLEARNING slows down forgetting decidedly. If an act has been practiced beyond the point of bare fixation, it will slip very little in the course of months. This fact accounts for the apparent superiority of motor retention. Most motor acts, such as swimming, typing, and driving an automobile, are practiced far beyond bare learning. A layoff of several months may produce some loss of skill, but the individual still retains a high degree of competence. If chemistry or psychology lessons were repeated as often as swimming or typing, details of each would be remembered well into middle age. In one study persons well practiced in typewriting omitted practice for six to eighteen months and regained their former proficiency quickly. [4] In another study a high degree of retention was shown for juggling two balls with one hand. [41] Originally forty-two days of practice were undertaken; after six years subjects surpassed their former skill in eleven days.

INTERMEDIATE PRACTICE. Intermediate practice freshens the memory and delays forgetting. This was demonstrated with advertising materials, using fictitious brand or trade names of commodities, such as "Pettal Perfume." [10] After a series of such names was presented, different groups of subjects were given second presentations three and ten days later. The study proved that for both recall and recognition a second rehearsal is beneficial. After ten days only 6 per cent of brand names were recalled; but when a second practice was held three days later retention was raised to 22 per cent. This situation is consistent with daily life; we see the same product advertised day by day in newspapers or week by week in magazines.

This and similar studies have resulted in practical suggestions on study habits and the optimum interval for inserting advertisements. A lesson cannot be reviewed every day, nor can most companies afford to advertise in every issue of a newspaper or magazine. The learning curve suggests that advertisements be spaced gradually farther and farther apart for maximum value. Thus, a product might be advertised each week for several weeks, then alternate weeks, and finally each month or so. In college courses some instructors give tests without advance announcement on the theory that the class will thus keep reviewed up to the minute. Constant and regular review of factual material greatly enhances memory value.

RETENTION OF INTERRUPTED LEARNING. A curious fact has cropped up in several experiments: material not quite learned has a high degree of retention value. [42] If the rather scanty evidence on this subject is correct, it would appear that anticipation of success had been developed in the learner before the process of acquisition was stopped. If he were to complete the learning, he would probably forget it. For

instance, subjects who were learning a maze were told that they would be expected to do three trials without error. [33] But when they had completed their first perfect run, they were told to discontinue practice. When tested for retention a week later this group was found to have slightly poorer memory than another group of subjects who had expected to do only one perfect trial, but had instead been asked to continue on until they had negotiated three without a mistake. The practice of interrupting continued magazine stories and serial moving pictures in the midst of exciting action is a device for sustaining interest and enticing cash customers. Unfinished gossip similarly leaves one in an unsatisfied state. We may forget the rest of the conversation, yet we will wonder for days about the conclusion of that particular story.

3. Is Anything Ever Totally Forgotten?

Even though we may not recall material once learned, both tests and daily life suggest that something once well learned does not entirely vanish. To test this theory, the technique of relearning has been employed. Although a subject apparently remembers nothing, if he is asked to relearn an original passage, it is found that the second learning occurs much faster than the first. The late E. B. Titchener, famous psychologist at Cornell, at the age of fifty-six reread Milton's "Hymn on the Morning of Christ's Nativity," a poem he had recited on his tenth birthday. He decided to relearn it, and after a few silent readings and several recitations with prompting, he recited it with but one slight error on the seventeenth trial. [43] Although he had no time data on his original learning, it was apparent that he could not have learned 216 lines as rapidly at the age of ten. Apparently much of the poem had remained; yet he reported that most of the poem seemed totally new to him on his first rereading. Warren also reports two cases of long-time memory. [45] His father at the age of ninety declaimed an eight-line poem learned seventy-five years previously. Another man of eighty-three, upon hearing that he was to be granted an honorary degree by his alma mater, recited the freshman oration he had given sixty-nine years previously. In a controlled study, 44 and 43 per cent retentions were reported for one hundred-word passages learned through auditory and visual presentations, respectively, after a lapse of five years. [48]

Memory does not have to be conscious to be valuable. Many of the benefits of education are of this sort. For instance, an engineer is more competent to tackle a problem in his field than a layman; yet he probably could not give the names of books containing the specific information.

4. Accuracy of Memory

How fast does forgetting occur? Is remembered material fairly accurate? How much error creeps in? Are there any additions?

Answers to these questions are important in determining reliability of court testimony. If testimony could be secured by an impartial agency immediately after an accident or a holdup it would be quite trustworthy. But since witnesses are called in behalf of either the defense or the prosecution, no such impartial technique can ordinarily be used. When, as in our courts, cases are tried months after the occurrences, and continuances produce further delays, a lapse of time intervenes during which forgetting may and often does occur. As a result, judge and jury have difficulty in ascertaining the whole truth and justice is sometimes defeated.

Several typical possible, or even probable, sources of error appear in many court trials, where there have been lengthy continuances, or where the suspect may have escaped and is not brought up for trial until long after the crime. Such a lapse of time is prone to produce several direct changes: all memories become less sharp, details especially tend to become hazy or to disappear entirely, typification may occur. Sometimes completely new data are introduced, although such errors are far less frequent than are errors of omission. Indirect errors are produced through both imagination and suggestion. If the witness gave extremely detailed recollections, we would suspect unwitting fabrication. It also might be asked of some witnesses: "If you saw such vivid events occurring, why did you not report them to the police at the time, instead of waiting until now?"

The manner of questioning also has much to do with the accuracy of replies by witnesses. Clever cross-questioning suggests answers and adds embellishments to the unprompted story a witness would ordinarily tell.

Facts not only may be forgotten, but errors and distortions may also creep in. However, it is probable that adults err less than they forget. For instance, in college examinations percentage points are lost oftener through omitted items than through definite errors. In one investigation of this aspect of forgetting, subjects studied pictures of football players and boxers in characteristic poses, and clippings from comic strips. They were requested to recall the pictures after intervals of seven, fourteen, and twenty-eight days. After seven days the background, setting, and colors were becoming indistinct. After longer lapses even the central figures became indistinct and hazy. In some cases it was noticed that the observer added details which he himself

had suggested in an earlier recall. For example, he might have asked himself whether the football player had a ball under his arm and on a second recall he said that he saw one there. [13]

A book entitled *Convicting the Innocent* cites several cases of miscarriage of justice due to faulty identification of accused persons. [5] A minister was arrested for grand larceny, positively identified by the victim, and found guilty by the jury. Later it was shown that he was not at the scene of the crime. In some of these cases the resemblance between the guilty man and the innocent suspect was close enough to cause confusion, but in others the wrongfully accused person bore no resemblance to the person ultimately convicted. Technically, we would say that such errors of memory were due to inadequate learning. The witness either had insufficient time, was in a faulty position, or was too excited to observe adequately.

The way loss and change of content occurs was illustrated in a study with seventh and eighth grade children. A passage of 209 words, dealing with familiar situations, was composed and given to six boys to read serially. [37] That is, the first boy studied and reproduced it as well as he could; then the second boy studied the first boy's version. Boy Three was given Boy Two's reproduction, and so on until the sixth boy had read it. Here is the original.

What Happened to Bill

This shouldn't be told, but I just saw Bill in the hall and it reminded me of something I heard about him through my friend, Carlos. It seems Bill was seen by a member of the Safety Patrol riding his bicycle down Gratiot toward Ten Mile Road with three other boys on the wrong side of the road. This member of the patrol, his name was James, did nothing about it at the time, but when Bill came to school, James gave him a ticket. Bill thought this was unfair to him since James had waited so long before he gave him the ticket and since he did not give the other three boys a ticket for the same offence. However, Bill had to report to the principal with the ticket. The principal talked to Bill about how dangerous it is to ride a bicycle on the wrong side of the street. He also told him that the law in Michigan regards bicycles as vehicles and that bicycle riders must obey the same laws as automobile drivers. Bill was punished. He had to sweep out the lower hall each afternoon for five days. You can't break the law forever and expect to get away with it.

The first boy reproduced it well, shortening it by only forty-three words, the most important change being a complete omission of the last sentence. The second boy was not quite so good, his version being

seventy-eight words shorter than the first version. Boy Three read the last passage, and gave this :

This shouldn't be told, but I heard it through a friend of mine, Carlos. Bill was headed toward Gratiot on a bicycle, with three other boys, on the wrong side of the road. James, a patrol boy, saw him, and the next day gave him a ticket. Bill thought it was unfair because the other boys did not get a ticket too. His punishment was that he had to sweep the halls the next five days.

The next two lost only seven and twelve words each, but did not change the character of the story materially. The sixth and last boy in the series dropped thirty-three more words, his version being simply :

I was told that Jim was riding his bicycle on the wrong side of the street. He was with three other boys on Gratiot.

This experiment may be compared closely to the winnowing of a story by frequent mouth-to-mouth retelling, and is possibly the way in which folk stories are polished and refined in the course of time until today many of them are almost cryptic in their brevity.

While from an experimental viewpoint the procedure of going from one subject to the next as employed in the last cited experiment was a little unusual, the findings are similar to those obtained when the same individual tells the story time after time. One investigator found that after ten reproductions the story had become much shortened and had attained a fairly fixed form. The principal ways in which changes had occurred were by shortening, by altering minor details, and by introducing explanations. The general form, or plot, remained substantially the same, but many errors of detail crept in. Time of day, numbers of people, style of wording, all changed. Here is a typical change: the water was described as cold; later it was said to be the coldest the story character had ever experienced. Many minor details were omitted entirely after a telling or two. Also, incidents that fitted in with the subject's preconceptions were well retained. [2]

Frequently *typification* produces erroneous memory. No doubt we have all read accounts of incidents which conformed to typical patterns. A confidence man is always well dressed and of gentlemanly behavior. Unusual and individual incidents of a situation drop out in favor of those which conform to an accepted pattern.

II. CAUSES OF FORGETTING

1. Is Passage of Time the Only Variable in Forgetting?

Learning curves are based upon the assumption of gradual improvement. Similarly, forgetting curves assume that passage of time is the chief variable in the disappearance of skills, habits, and knowledge.

This loss of skill with time has been compared to the disappearance of a path through the woods, which when unused and neglected is quickly covered up by grass, shrubs, and finally trees. This analogy assumes that the environment remains passive, and that retention is solely a function of time.

But we have seen that practice alone does not produce learning; it may produce no improvement at all. Certain conditions may make one unit of practice far more effective than another. Just as we have seen that one learning trial may prove far more beneficial than another, so the situation that follows learning may affect the quality of retention. This is the gist of this section.

As time passes, memories diminish in quantity, sharpness, and accuracy. But is it just a question of time, as in the neglected path analogy? Might it not be due to intervening events which stand in the way of and interfere with memory? This might happen if we were to transplant trees onto our neglected path, instead of allowing nature to work unaided. Let us give a psychological illustration. We have certainly forgotten the names of many playmates of ten years ago. Is this solely because ten years have passed, or may it not be because we have become acquainted with many new people? Forgetting may be not so much a matter of slow decay as of the interference, inhibition, and obliteration of the old by the new. New things are learned and they take the place of earlier material. [26]

2. Interference as a Cause of Forgetting

(A) **RETROACTIVE INHIBITION.** In laboratory tests of memory it has been discovered that learning a second selection interferes with retention of the first. [6] For example, a subject is asked to learn a sixteen-line poem; then he is asked to learn a second poem. After he has learned the second, he is tested on his retention of the first. In such cases the subject has poorer retention than if he had merely rested the same length of time and had not become engaged in learning the second poem. This phenomenon has been given the imposing name of "retroactive inhibition." It means simply forgetting occasioned by intervening events.

(B) LAWS OF RETROACTIVE INHIBITION. Loss of memory is greater if:

1. The intermediate or interpolated material is similar to the original.
2. The psychological activity demanded during the interim is intense.
3. The interpolated material is introduced directly after the original learning.
4. The original material has not been well learned.
5. The original material is of nonsense or unfamiliar character.

Here are two illustrations from everyday situations. One attends a reception from four o'clock until five and meets many strangers. He attends another from five to six and also meets many new people. That evening he tries to recall the names of people he met at the first reception, but finds that the second affair has interfered with his memory of the first. In the evening he studied French from eight to nine, and Italian from nine to ten, and he finds the next day in French class that the Italian, which is very similar to French, is confused with it. If he had not studied Italian, he would not have experienced so great a loss.

(1) *Similarity*. Within limits, the more similar the two materials studied the greater the interference between them. In the above example, losses would be greater if the guests at both receptions were of the same character, say all students or all middle-aged men, than if the two sets of guests were of widely different classes. With languages, there is more inference between French and Italian—both are derived from Latin and are so similar that a person who knows French and Latin can read Italian with fair meaning—than between two languages of entirely different origins, say Polish and Chinese. Further, we might expect more interference between two languages, regardless of which two, than between a science and a language.

Interference may occur not only because of similarity of detailed contents, but also because of their general nature. In one case greater interference was produced by the interpolation between learning and retention of synonymous adjectives than occurred when antonyms and unrelated adjectives were used. [30] Here the interference was in the form of meaning. It is possible that more loss would occur if the form were the same, say two poems of like meter or two prose passages on the same topic.

Naturally, if the two materials should happen to be largely identical in content, such as the same set of people attending both receptions, or two parallel scientific passages, there is reinforcement rather than interference. The learner practices the same thing twice. The dividing line between similarity and difference has to be individually determined.

(2) *Intense concentration increases retroactive inhibition.* In the experiment just quoted, if the period between learning and retention were occupied by light reading, listening to music, casual conversation, exercise, or rest, there would be a lesser loss of memory of the learning activity, regardless of degree of similarity. There was almost as much loss in learning nonsense syllables as in memorizing additional lines of the same poem. [32] In another study subjects were given slight electrical shocks from time to time as they read *College Humor*; they memorized 5 per cent less than those who were allowed to read without distraction. [27]

(3) *The closer in point of time the interpolated material follows the original learning the greater is the interference.* If one is given an hour's interval between learning and the test of retention, with fifteen minutes' additional learning interposed between, he loses more of the original if the second learning occurs immediately after the first than if it comes later. If the second learning activity came during the middle of the hour, say between the twenty-fifth and fortieth minutes, the interference would be much less.

(4) *Interference is greater if the original material has not been thoroughly learned.* Subjects practiced lists of nonsense syllables different numbers of trials, from 6 to 26. [28] Between learning and recall another list was interpolated, given uniformly 11 times to each group. The results were that:

$$\text{Retroactive inhibition was } \left. \begin{array}{l} 82\% \text{ after } 6 \\ 78\% \text{ after } 11 \\ 65\% \text{ after } 16 \\ 62\% \text{ after } 21 \\ 46\% \text{ after } 26 \end{array} \right\} \text{ original trials}$$

(5) *Retroactive inhibition is less when the material is familiar or meaningful.* Both prose and poetry are much less susceptible to interference than are many other materials commonly used for testing. [29, 32] Hence we could say that two generalized sets of facts or principles are less subject to retroactive inhibition than two dates or two formulae.

(C) EXPLANATION OF RETROACTIVE INHIBITION. Three principal theories attempt to explain this important phenomenon. [8]

(1) *Perseverative activity.* When contact with the material has been completed, neural activities apparently do not cease activity immediately, but taper off gradually, like pain from a sharp blow. This continuation of nervous activity, even if of lesser intensity, aids in fixating associations. If a new activity is initiated immediately, interference is set up.

This same explanation has been used to account for the advantage of distributed practice; concentrated practice prevents the possibility of perseverative activity assisting fixation.

(2) *Negative transfer*. Data on the similarity of materials suggest that interpolated materials may become confused with the original. This accounts for interference weeks after the original learning, a phenomenon which perseveration cannot explain.

(3) *Disruption and transfer* combined produce a theory which fits in with the majority of findings on retroactive inhibition. Some similarity of contents, materials, meaning, form, or methods of attack may all serve to produce disruption between one learning task and another, whether preceding or subsequent.

As is usually the case when several alternative explanations have been advanced, there is partial truth in each. Each fits some but not all of the facts. It is impossible even to select one theory as the leading one. Therefore, let us utilize each in a practical way.

(D) PRACTICAL SUGGESTIONS. Several hints may aid in memory. In keeping with the perseveration idea, it is advisable to rest between intensive sessions of study, in order to allow impressions gained in the first to integrate themselves. One might spend fifteen minutes writing a letter, listening to the radio, or straightening up the room, as a rest between intellectual activities. The possibilities of negative transfer can be obviated by avoiding the study of two similar courses in immediate succession. Suppose one has to study French, Italian, and chemistry in one evening. Instead of that order, it would be best to interpolate chemistry between the two languages. This might apply, under the "disruption" hypothesis, to the whole semester as well as to one day. It is preferable to avoid beginning two foreign languages or two natural sciences in the same semester.

3. Retention Values of Pleasant, Unpleasant, and Indifferent Experiences

This topic ties up with the principles of effect and vividness, but here we are interested in the influence of emotional tone upon memory rather than upon learning.

Experiences are pleasant, unpleasant, or indifferent. In addition, they may be somewhat pleasant, such as walking on a sunny day, or extremely pleasant, such as dining with an old friend. Similarly, they may vary from mildly unpleasant, such as boredom from a long movie, to highly unpleasant, such as losing one's job or being expelled from college.

The relationship between emotional tone and memory is difficult to

study satisfactorily in daily life situations, and laboratory studies are often too abstract in their methods and implications for ready transfer to daily life. Cason [12] conducted one such study by asking students to recall recent events which were either quite pleasant or quite unpleasant. Three days later the students were asked to rate the episodes again from extremely unpleasant to indifferent to extremely pleasant. After another lapse of three weeks a third rating of the same experiences was requested. The proportions are summarized in Table 38. It is seen that both pleasant and unpleasant episodes veered toward the indifferent as time went along. At the time of an experience or shortly thereafter it is usual to feel strong emotion of one kind or the other, but a few weeks later it is commonly felt that the incident was pretty humdrum after all.

TABLE 38
TREND OF FEELINGS TOWARD PAST INCIDENTS

Feelings	Pleasant	Indifferent	Unpleasant
During original incident...	54%	4%	42%
Three days later.....	50%	23%	27%
Twenty-four days later....	45%	29%	26%

The unpleasant experiences, in this investigation, faded out in emotional tone more rapidly than did the pleasant, dropping 16 per cent in contrast to the 9 per cent loss for pleasant. The experiment also showed that extremely pleasant and extremely unpleasant events are most often recalled.

In the above study subjects were reminded of their own past experiences. In another, a different approach was used. [46] The day after they returned to college from Christmas vacation 245 students were asked to write all the pleasant and unpleasant experiences of the holidays. Different groups of students were then asked for a second recall at intervals of from 2 to 140 days. The investigators found, in agreement with Cason's results, that there was a shift toward less pronounced feelings, but that the most vivid experiences were best remembered.

Substantially the same technique was used in following up the original narration of experiences by an unannounced recall six weeks later. [34] Sixty per cent of the originally recorded unpleasant experiences were not recalled, although only 40 per cent of the pleasant ones had been forgotten. Individual differences appeared even here: the optimists forgot more unpleasant than pleasant experiences; the pessimists forgot the pleasant and retained the unpleasant. [35]

There are at least two difficulties in such studies. First, in order to establish a control, we must ascertain what percentage of life is pleasant and what unpleasant. If two-thirds of what we recall is pleasant, it proves little unless we can find whether just two-thirds of our experiences are pleasant, or whether the true proportion is greater or less. If only a tenth of our life is unpleasant, but a fifth of what we remember is unpleasant, then unpleasant experiences have a high memory value. Second, the individual himself may change the rating of the emotion. An embarrassing experience may at a later time be considered a huge joke. Or a person will claim that he really was not so embarrassed as others thought, if only to protect his ego.

Together with retention of the unpleasant, one tends to remember incidents in which he has been frustrated. The examination questions one missed are remembered better than those one answered correctly. A person may brood for days over his failure to make a "wisecrack" or a sarcastic comment at an appropriate moment. A football player may remember times when he just missed being a hero, and he may forget occasions when he was more successful.

From the investigations reported here and from others not specifically discussed, [36] a few tentative conclusions emerge:

1. Both pleasant and unpleasant experiences are better retained than are indifferent ones.
2. Vivid experiences, regardless of their personal significance, are better retained than ones which are comparatively dull.
3. Pleasant experiences appear to have slightly better memory value than unpleasant.
4. But since there is so little difference between retention of pleasant and unpleasant, memory is probably influenced more by the violence of the emotion than by its character.
5. Extremely unpleasant episodes may either be repressed entirely from memory, or the individual may alter their emotional tone to render them more bearable.

This last point calls for a little explanation. Unpleasant experiences may be actively repressed from consciousness. This is the basis for many theories in psychiatry and psychoanalysis. Exceptionally unpleasant incidents may be so painful that a person may become hysterical if he cannot get rid of them or laugh them off (that is, alter the emotional tone). If the latter is impossible, they must be actively forced from the mind. Amnesias, dual personalities, and hysterical paralyses occur because unconscious memories exist within ourselves and exert definite influence.

4. Concussion Amnesia

Quite commonly when a person has met with a violent accident in which he has been knocked unconscious, he finds that he has lost memories for several hours or even days. Such losses follow regular lines, except in cases of actual destruction of nervous tissue. There are four main trends in such concussion cases :

1. The loss is in point of time, rather than in subject matter. For example, the patient may be found to have a gap for everything which occurred during the last week or month, not a gap of all mathematical knowledge.
2. The loss of memory is proportional to the severity of concussion. It may extend back a few minutes, or even a few years in cases of severe brain injury.
3. As recovery takes place, memories are revived from the past toward the present. Loss may have been for a few months, but is reduced to a few weeks, then a few days, but usually the last few hours or minutes are never recovered.
4. The permanent loss is proportional to the severity of concussion.

Here are two typical cases, showing the effects of one severe and one more mild injury.

Case 1. Student, driving late Sunday afternoon to a city 30 miles away was hit head-on by a car out of its lane. The force was so great that he was thrown through the top, and landed on his head fifty feet along on the concrete pavement. The engine of his car was found on the seat. He was very fortunate not to have been killed. For about a month he was practically unconscious, and his nervous system was so disorganized that he had no control of even eliminative reflexes. When he began to recover the doctors brought in friends to talk with him, to discover what possible after-effects may have occurred.

He had forgotten everything of the last two years. He might recognize a fairly casual acquaintance whom he had known two or more years, but even a very close friend whom he had met within two years was a total stranger to him. But in the course of six months the loss gradually diminished, until finally he could apparently recall all but the last few hours. He was reminded of having had lunch with a certain friend, but since that was a common occurrence, he could never be quite sure whether he remembered that particular lunch or whether he was conjuring up a sort of typical lunch situation.

Case 2. Another student was found on the drive between the center of town and the university. He had apparently been hit by a passing car. Having just returned from Christmas vacation, it was easy to check on recent

memories. For a while he had forgotten even having left home, 27 hours previously, but eventually he recovered all but the few minutes prior to the accident.

Boxers and football players who have been knocked unconscious rarely remember the blow or the play. In a championship fight one contestant was knocked down in the third round, but was not knocked out until the twelfth. He could remember nothing after the first knock-down. It appeared that he had fought for nine rounds virtually on a subcortical level. In another wild slugging match, in which each man was knocked down several times, the winner's mind cleared up later, and he asked in what round he had been knocked out.

Apart from the interest these facts have for their own sake, they may be applied directly to our discussion of learning and forgetting. Since events just preceding an accident are forgotten, there is evidence that the mind must be in a normal condition for a time following an episode if material is to become integrated and retained. We might even term concussion a sort of violent retroactive inhibition, since we have a parallel case in which events subsequent to the learning interfere with retention of the original learned material.

5. Forgetting During Sleep and Waking Hours

As we have seen, there are two main theories of the cause of forgetting: first, that as time lapses, memories fade out; second, that events occurring after the original experience tend to overwhelm and drive it out of the mind. Sleep should furnish a crucial test of this, since we can compare forgetting over a certain number of hours of daily activity with the same number of hours spent sleeping. Duration of time remains constant; the only remaining variable is the intermediate activity.

In several experiments it has been shown that less forgetting follows a certain number of hours spent in sleeping than follows the same number awake. [14, 16, 44] Greatest advantages occur when the normal amount of sleep, say eight hours, has been permitted. One investigator found that the two curves of forgetting coincided for the first hour, but that there was virtually no further forgetting during the next seven hours; forgetting while awake followed the typical forgetting curve.

Since pictorial results often illustrate differences meaningfully, we reproduce the curves of forgetting obtained in a well-known study by Jenkins and Dallenbach. [20] Here the same trends appear as in the other investigations. Even during the first hour or two of sleep the subjects suffered slightly less loss than while awake. (This loss may

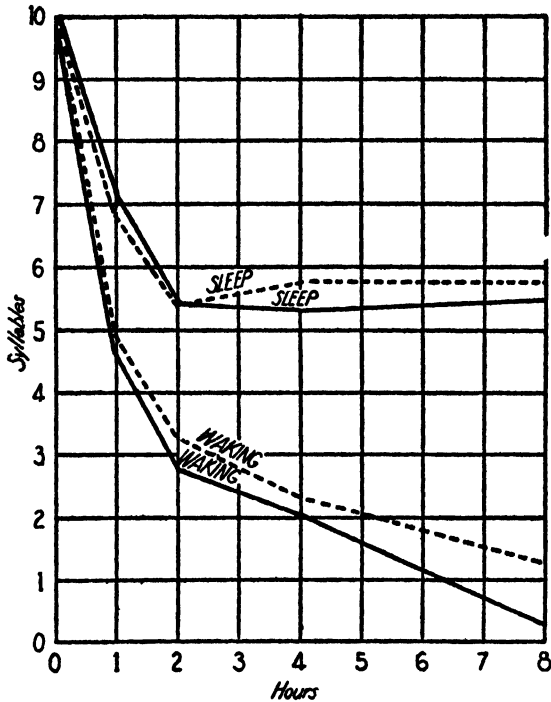

FIG. 51.—Curves of Forgetting During Sleep and Waking.

More syllables are retained when one is asleep than when the usual interferences of daily life are present. (From Jenkins and Dallenbach.)

not have been genuine, but may have been due to difficulty of recall when a person is suddenly awakened.)

It would be interesting to see what might happen if the period devoted to sleep could be lengthened, but with human beings this is impracticable. A human being cannot regularly sleep much longer than eight hours. It has been suggested that if animals could be taught a simple habit shortly before they go into winter hibernation, we could have a measure over a longer period of time, but this speculation will have to await the efforts of an ambitious investigator.

6. Reminiscence: Revival of Previously Forgotten Material

One of the peculiarities of memory is that occasionally a person is able to recall more material a few hours or a few days after learning than he could directly following learning. Ballard [1] in 1913 conducted an experiment with nearly ten thousand English school children which has been the subject of debate ever since! Instead of having the

children learn the material completely, the investigator asked them to study typewritten selections from "The Wreck of the Hesperus" and "The Ancient Mariner," as well as some nonsense syllables, for fifteen minutes. Then he gave an immediate recall test, and left the schoolroom without giving any idea that he might come back to test retention. But he reappeared in various schools and grades anywhere from one to seven days later. From the memory curves for poetry presented in Fig. 52, we see that the children showed greater recall after two or three days than immediately after learning had terminated. For example, on a basis of an arbitrary value of 100 for the amount put down on immediate recall, the six-year-old children reproduced 160 per cent of that amount three days subsequently.

Most studies have failed to verify these results, but some do concur. In an Italian study reminiscence appeared in terms of reliability of court testimony. [39] Responses during the first week or two tended

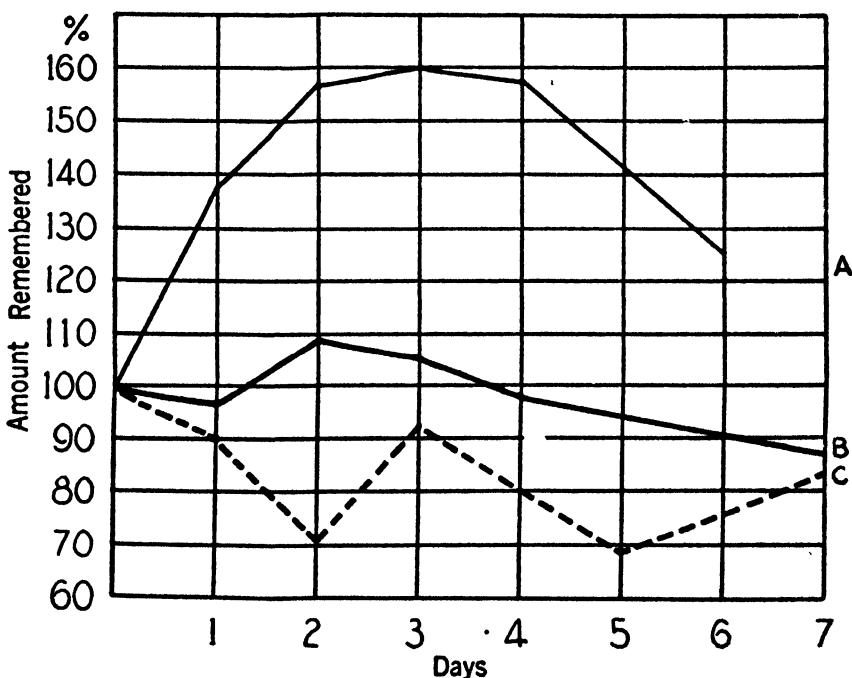

FIG. 52.—Memory Curves for Learners of Various Ages.

Reminiscence is shown by greater retention at some later date than immediately after learning. Group A, the six-year-old children, remembered more after several days and showed greater reminiscence than older persons. The phenomenon appears to only a slight extent with fourteen-year-olds (B), and not at all with adults (C). (From Ballard.)

to be erroneous, but after the third week very little error appeared. A study by two Chinese experimenters [22] showed that children had more reminiscence than adults, but nonsense material never showed a score of greater than 100 per cent of the original recall score, regardless of time of retest.

Ballard's results contain three suggestions: (1) That the phenomenon of reminiscence is largely confined to children; (2) that it appears mostly with meaningful material; and (3) that it probably can only appear with partially learned material. However, in another study no significant differences in reminiscence between preschool children and college students were found. Nor did intelligence or degree of original learning prove important. [23]

These findings are surprising, and naturally they raise many questions. In the first place, are the findings true? Might there not have been some uncontrolled element which allowed this gain to appear? Some rehearsal is possible, but since Ballard gave no notice of possible later testing, it seems unlikely that many of these young children would go to that trouble. Some new items are likely to come back, much as a student recalls information hours after he has taken an examination, but one might logically expect several old items to be lost for every new one which reappears.

7. Discussion and Summary: Active and Passive Forgetting

Two main causes of forgetting appear to be at work: lapse of time and interference due to subsequent events. It is possible that both are at work at any time, since in every case time elapses between learning and test of retention, and since in the normal routine of life there are many interferences. It is impossible to isolate each of these possibilities, but there is ample evidence that passage of time is not the sole source of forgetting.

Let us review briefly some of the evidence. First, there is retroactive inhibition, that is, similar and intense activities produce a greater and more rapid loss than do different materials or resting states, in spite of equality in the time element. Then, there are different retention values for pleasant, unpleasant, and indifferent experiences, a fact which demonstrates that emotional tone has an active influence on memory. Evidence from concussions and waking versus sleep shows that memory is facilitated if the mind remains in a normal, quiet, resting state following learning. It is possible also that the disadvantages of massed or concentrated practice are due to temporary interference.

It is certain, then, that the quality of memory is influenced by subsequent activities. But whether or not one considers interference as the

chief, or only, cause of forgetting depends upon a personal evaluation of the evidence. The author is convinced that both forces—passage of time and interference—are at work. A final solution of this problem may be reached through an experiment comparable in nature to the suggested hibernation test of animals. A human being might be placed in the well-known desert island situation, where possibilities for interference would be at a minimum. Months or years later we might test his memory of former friends or school subjects and compare the results with those for persons who had gone to work or gone further in education. In one case there would be little more than mere passage of time, and in the other time plus interference.

III. IMPROVING MEMORY

1. Possibilities of Improvement

Two questions arise in connection with improvement of memory. First, is the quality of memory a thing one must accept, as a chronic invalid bears an incurable disease? Or can one improve his memory so that he does not forget facts, names, and appointments? Second, does one really have special disabilities in remembering names, faces, dates, or appointments, or are differences in memory due to interests and experience? We constantly hear people say, "I never forget a face, but I simply can't remember names." Is this a legitimate complaint? As we shall see, such a person is really admitting that he is more interested in faces than in names, and that he pays little attention to names when introduced.

Forgetting must be due to one of three causes, each of which has been mentioned previously:

1. Poor learning: material that is incompletely learned fades quickly.
2. Decay through passage of time.
3. Interference: retroactive inhibition, concussion, repression.

We can partially control each of these sources of declining retention. Poor learning may be overcome by better techniques of acquisition. Loss from passage of time may be averted by rehearsal and intermittent reviews. Interference may be minimized chiefly by avoiding conflicting activities for a short period of time after learning.

The cause of forgetting most susceptible to elimination and control is that of quality of learning. Accordingly, much of our discussion will center about ensuring better retention by means of securing better learning. We shall lay emphasis not only upon school learning, but also upon memory for everyday affairs.

2. Efficient Learning the Keynote

Efficient methods of learning are reflected even more in firmness of retention than in saving of learning time. At the moment an inefficient method may not seem to be particularly wasteful, but a month later its poor retention value will be evident. For example, students who pay strict attention during a lecture may average only a few points higher than less attentive members of the class in a five-minute test given at the conclusion of that hour, but a month later the first group will be far ahead.

Since retention is so dependent upon the quality of the original learning, let us bring together for review several of the more important principles or laws of learning.

1. The greater the incentive to learn, the more rapid the learning and the more permanent the retention.
2. The more times a thing is rehearsed, the more firmly it will persist.
3. If an act is practiced beyond bare learning (overlearning), the memory value will be far greater.
4. Vivid incidents, whether pleasant or unpleasant, are better retained than those more neutral in character.
5. Meaning is of great aid to learning and retention.
6. Active learning, say by recitation, produces more permanent retention than a more passive attitude.
7. Learning by wholes and the distribution of practice insure better memory.

Since the majority of these principles have been adequately discussed, we need not expand upon them. Additional comment is in order, however, with regard to ways of applying several of them.

Here are three of the most important rules for learning:

1. Pay careful attention when in the original situation.
2. Make actual and frequent use of what you wish to remember.
3. Try to understand, rather than to learn by rote.

When a person says he has a poor memory, in most cases the truth is that he has never learned. Absent-mindedness is an example of this. If you ask a friend who is engaged in reading a newspaper to meet you after work for a cup of tea and he fails to meet you, you should realize that your invitation never recorded itself in his nervous system. It was not a legitimate case of forgetting. Likewise, if one acknowledges an introduction by saying "I'm glad to meet you, Mr. M-m-m-m-m," he should not expect to remember the name or be surprised that he

cannot recall it when next he meets the man. One cannot remember what he has never learned. If you have an absent-minded friend who constantly neglects appointments, you will do well to make sure that you have his attention and then ask him to repeat the time and place.

At a reception I once talked with a college president who had quite a reputation for remembering people's names. I asked him how he accounted for his prodigious memory, and as he started to explain that he made a point of using each individual's name several times during a conversation, I was treated to a demonstration of his technique. In response to an introduction he said, "It is a pleasure to meet you, Mr. Johnson," and in the course of a three-cornered chat he used Mr. Johnson's name several times, such as "now, Mr. Johnson, what is your opinion of . . . ?" In that way he used the name actively (recitation) several times (frequency).

If a person realizes that he has a certain shortcoming, he can correct it by special efforts. As one man said:

I realized that I did not remember people because I had fallen into the habit of identifying them by their clothes instead of by their features. I would meet Miss Smith at a dance, and the rest of the evening would identify her by her red dress, but the next day I might meet her on the street in sport clothes and not realize that I had ever seen her before.

Having thus diagnosed the cause of his embarrassing failures, this man forced himself to study the person's face, and thus he furnished himself with a sounder basis for retention.

Understanding of meaning is just as valuable for retention as it is for learning. Some students attempt to pass examinations, especially in technical courses, by memorizing formulae, dates, or proofs in rote fashion. Such material slips very quickly. Once material is well understood, it can be retained for months or even years. The old saying "A liar needs a good memory" is in line with this principle. A "made-up" story does not have logical associations surrounding it, it will probably contain contradictory points, and it will be difficult to repeat exactly. But if a person tells the truth he need not worry about inconsistencies.

3. Mnemonic Devices

Several schemes have been advocated for improving the memory: you are supposed to form a network of associations about a name, a date, a person, and so on. Most of these devices are illogical. Here is one sample. [38] One desires to remember the name of a man named MacErwin: He thinks of a Mack truck, then it skids (err), but gets back to the road (win). When one meets Mr. MacErwin, he is sup-

posed to get those images and greet him correctly. The birth date of the early German psychologist Herbart, 1776, is easily remembered because it is the same as our Declaration of Independence. However, not all names and dates are so convenient or have such ready-made logical associations. Just as a trial, six names were taken at random from a telephone directory by shutting the eyes, opening to a random page, and touching the paper with a pencil. These names turned out to be: Hansen, Morgan, Markham, Karch, Saunders, and Sprague. Have any of these logical memory value for you?

Meaning can often be built up. The stockbroker may seem to be performing an amazing feat by quoting closing figures on dozens of shares, but he knows that a certain stock in the last few weeks has been running about 100, that another is around 16, that a third tends to be near 70. He also knows that the trend of the market was up or down, and about how much. Therefore, his task really reduces itself to remembering the departures of any issue within a narrow range. His errors, if any, would necessarily be fractional, since he has a great deal of information with which to tie up his memories. Track fans return from a college meet and amaze their friends by reporting the time and distance of every event. The importance of meaning, and not merely rote memory, is demonstrated in meets where metric distances are used instead of yards. One who knows how to judge the merits of a 4:15 mile or a 24 foot 6 inch broad jump is at sea when he is told that the 1,500 meter run was won in 3:55 and that the broad jump distance was 7 meters 90 centimeters.

In general, the value of a mnemonic system or special method of studying is based upon actively handling and dealing with the material.

A student, while reviewing history for the final, decided it would be a good stunt to draw a huge chart, with names and dates all arranged in proper chronological order, and with interrelationships shown by connecting lines. This proved to be more of a task than he had anticipated, but he became so absorbed that he finished it just fifteen minutes before the hour of the examination. He had no time to restudy it, or to review the course in any other way, but he found that he had acquired a fine grasp of the entire course.

In this case the student spent so much time actively arranging his material that he learned it in the process.

4. Incidental Memory

Many of our memories are of things which were not learned purposefully, but of events or materials which were acquired unintentionally,

that is, *incidentally*. If one wrote down everything he had learned, it is probable that he would find that most of his learning had occurred in this way. This is truly a neglected topic in psychology, since most experimental studies in learning and memory have concerned themselves with situations in which the learner paid deliberate attention to the task.

One might assume, and correctly, that incidental learning is decidedly inferior to purposeful learning. Inability on the part of most people to answer certain simple questions demonstrates this fact. Is the hour for six on your watch represented by a "6" or a "VI"? Most people will answer one way or the other but usually incorrectly, since most watches have no such symbol at all. Another question: how many steps are there in your house between the first and second floors? You have climbed them hundreds of times, and you probably don't know the answer; but if you had counted them just once or twice you would remember. Spelling errors furnish additional evidence. In psychology, words like heredity and environment appear again and again; yet in final examinations students misspell them. Seeing the correct spelling is no guarantee of ability to reproduce it.

Intention to remember definitely enhances memory. In one study, pairs of students learned twenty nonsense syllables, one reading to the other who was memorizing. [19] The learner twenty-four hours later recalled 15.9, and the reader 10.8 syllables. These differences are not great, but the reader had to pay close attention, even though learning was not part of his task.

A clever study on incidental memory was conducted by Burt. [9] He read aloud to his son a number of passages of Greek tragic poetry when the boy was between eighteen months and three years of age. The boy could not understand the passages, nor would he make a deliberate attempt to remember. Twice later, when the boy was eight and fourteen years old, Burt had him learn the passages which had been repeated in his presence in infancy, and as a control had him learn other passages from the same plays. When he was eight, a saving of 40 per cent occurred; that is, it took him 40 per cent fewer repetitions to learn passages with which he had had previous contact. There was less saving when the boy was fourteen years old; new passages took only 8 per cent longer than ones he had heard before. Still, there was some saving, and we see in both halves of this experiment that something was learned and retained, in spite of the boy's infancy, the incidental learning, and the completely meaningless material.

Unfortunately much of our school and college learning is acquired in the same way that Burt's son learned. Even if we are truly in-

terested in the book we are reading and feel that we are concentrating well, we leave learning and memory pretty much to luck, hoping that we will retain a certain amount of the material. Typical learning too often consists in reading a chapter once, perhaps skimming many of the paragraphs, and then slamming the book shut and running off to visit a friend the instant the last sentence has been read. Again, let us remember the principles of efficient learning. It is necessary to read more than once, to go over crucial passages a second or third time, to recite actively, and to mull over the entire section for significance and possible applications.

5. Speed of Learning and Retention

This problem demonstrates that another old proverb, "Quick to learn, quick to forget," is a fallacy. Some people assume that individuals who are slow learners are thereby ensured a more tenacious memory. A number of experiments clearly demonstrate this assumption to be false. In general, the more rapidly a person is able to learn the better also will be his memory.

While engaged in a study of maze learning, the author once tested this principle by asking subjects in the top 10 per cent in speed of learning and those in the slowest 10 per cent to come back in a week "to learn a new maze." Because class schedules are the same from week to week, there was a lapse of exactly a week to the hour. None of the subjects suspected a memory test. When the subject returned the next week, he was blindfolded, and told that he was to relearn the original maze. No one in either group had suspected that recall might be demanded, so that intermediate rehearsal was not possible. In Table 39 we see that those who learned most rapidly the first time also had the fastest relearning scores, in spite of the fact that they needed fewer trials, and hence had less practice, during the first learning. [17]

TABLE 39
RELATION BETWEEN SPEED OF LEARNING AND QUALITY OF RETENTION
IN MAZE LEARNING

Group	Learning	Retention
Average	24.2 trials	no test
Best learners	13.4	5.4
Slowest learners	43.8	14.2

Another investigator studied the same problem with a novel technique. [47] Instead of allowing a subject to overlearn familiar Italian-

English combinations while practicing those which furnished greater difficulty, he dropped each pair out as soon as it was correctly repeated once. Thus, each associate should have been learned equally well. But when retention was tested a number of hours later it was found that those associations which had been learned most easily were also better retained. As presented in Table 40, we note that vocabulary items which subjects knew correctly after one repetition were remembered 73 per cent of the time; those which took more than five trials to learn had a survival value of only 27 per cent.

TABLE 40
RETENTION OF VOCABULARY ITEMS

TRIALS TO LEARN	PERCENTAGE RETENTION
1	73
2	72
3	63
4	58
5	38
6-11	27

Both these experiments demonstrate apparent violation of the principle of frequency. In the first, those subjects who had had the greatest amount of practice on the maze pattern profited the least. In the second, those vocabulary items on which the most time was spent in learning had the lowest memory value.

These findings show that a person who learns quickly also has better memory, and that the more quickly one can learn a subject the better he will remember it. Concretely, if you can learn your history as well in an hour as you can your chemistry in two hours, you will remember history better. And if you can learn the same lesson as well as your roommate in half the time, you will have longer retention than he.

6. Improving Retention

Most of our discussion has dealt with assisting memory indirectly by improving the efficiency of the original learning. Let us now assume that learning has been completed, and that we are primarily interested in preventing retention from fading, whether through passage of time or through interference.

We have all seen advertisements for systems to improve the memory. Typically, they take the form of a testimonial something like this:

Seventy-five of us were asked to a banquet to meet Mr. Iva Bigg Memory. On entering the hall we each were introduced to him; he asked

us each in turn our address, telephone number, business, the number of children we had, and our age. After the dinner he spoke, and surprised us all by calling back all these facts without making a single mistake. I thereupon signed up for his course and profited so much that my business has tripled in the last six months.

Assuming for the moment that this statement is correct, such systems are really learning methods and not schemes for improving memory.

(A) **UNIQUENESS.** Uniqueness is an aid to memory, in that meaning is provided and interference forestalled. There are daily instances of the value of contrast. A lecturer meets hundreds of students daily, but only a few stand out from the crowd in a large lecture hall. The situation is reversed when the lecturer pays the cashier in the restaurant or the ticket seller in the railroad station. The cashier and ticket seller will be remembered after several meetings, but they in turn will forget his face among the hundreds of people they meet every day. Certain people attract attention because of unusual features, expressions, or dress. They will usually be remembered in terms of these unusual aspects.

(B) **REHEARSAL.** Rehearsal keeps impressions from fading out and interference by more recent impressions from cutting in. Facts must be used to be retained. One must use telephone numbers and street addresses, must see old acquaintances from time to time to recognize them, must use chemical formulae or names of nerves, and must recite poetry, if he wishes such material to be available on demand. This applies especially to contents of rote nature. One often remembers general principles for years; but figures, disease symptoms, or foreign language vocabulary, which have fewer associations surrounding them, need occasional review.

(C) **KEEPING IN PRACTICE FOR LEARNING AND REMEMBERING.** Practice is claimed by some to be an important factor. This sounds suspiciously like the faculty psychology discussed in connection with transfer of training, but we shall present the arguments for what they are worth. It is said that what appears to be diminished learning and memory ability in older people is partially rustiness and partially loss of desire to keep alert mentally. A distinguished ichthyologist once said, apropos of his failure to remember names, "Every time I learn a person's name, I forget the name of a species of fish." It is false to assume that one can accumulate only a certain amount of information. But the veteran actor who constantly learns new lines, the elderly scholar who keeps up with the progress of learning, and the experienced lawyer who

follows the latest court decisions are all keeping their learning and memory alive by constant practice and demonstrating that it can be done if motivation is sufficiently strong.

(D) **MOTIVATION.** Motivation is a powerful factor in memory as well as in learning. Frequently the reason for forgetting an appointment is that there was no especial desire to keep it. If he should lose by the error, he would rarely forget. If a person is expected to do another person a favor, he may easily forget; if it is a much-desired invitation to a dinner party, there will be a definite desire to remember. In some cases, of course, there is a conflict: he may value the dinner invitation, but hate to lose an entire evening's time.

There is no profit in attempting to commit everything to memory. We do not need to burden our memories with facts that can be found readily. Lists of seldom-used telephone numbers save the trouble of memorizing routine information. It is said that there are two kinds of information: what a person knows and what he knows how to find out. This second type includes numbers and addresses, railroad schedules, historical dates, and technical information. Special bits of information, such as future appointments, are best jotted down on desk calendars, both to save mental effort and to forestall the danger of forgetting.

7. Deliberate Forgetting

So far in our discussion we have assumed that it is desirable to retain what has been learned. Occasionally, however, it is desirable to free oneself from an unpleasant or socially undesirable habit. Some everyday examples are: too much smoking, a consistent mistake in pronunciation or grammar, a breach of table etiquette that has become habitual.

(A) **METHODS OF ELIMINATING HABITS.** There are three principal ways in which to get rid of an undesirable habit.

(1) *Continued disuse.* One forces himself to avoid the unwanted habit. The dope fiend or drunkard wants "just one more." No habit is ever broken in this way. Many students fall into the habit of studying with a radio turned on. Although they may realize that they cannot concentrate under such conditions, they may find it difficult to readjust working habits. The room may seem disconcertingly silent. One student reported that this habit had disappeared after a summer vacation spent without access to a radio. When he returned to school in the fall he did not think of using the radio except for special broadcasts on subjects that particularly interested him.

(2) *Substituting* a new habit. One takes special pains to use a more correct, or more desirable, habit in place of the old one.

A well-educated man realized that his use of the phrase "do it good" belied his training, so he took special pains to say "do it well," for several weeks, after which he found himself using the adverb appropriately, and found that the incorrect habit had no tendency to recur.

In contrast:

A lady moved from a hundred miles west of Boston to the same distance from Chicago. The situation was so nearly the same that when she thought of going to the big city, she habitually said "Boston." Realizing her error, she would laugh at her own mistake, but would repeat "Boston" several times in an amused tone. The habit still persists, even after several years.

By giving "Boston" the advantages of practice or frequency, she perpetuated the habit. This was exactly the wrong approach.

What is termed *perseveration* may be eliminated by this process of substitution. Perseveration is the persistence of an idea, poem, or musical selection. Here is one example.

"I was much annoyed for several months by finding myself whistling Schubert's Marche Militaire whenever I went walking, and finding myself marching in step with the rhythm. I overcame this habit in the course of a few days by catching myself in the first few bars and deliberately switching to some other piece."

A persistent emotional state must be considered a habit as much as is any muscular or verbal act, and often it may be treated in much the same way. In the case of an emotional upset, say a broken love affair, a change of scene is sometimes suggested. Otherwise, owing to reintegration (page 437) all elements but one of the previous situation are present to serve as a constant reminder. One passes a restaurant, a theater, a night club, all of which have an emotional association, and is unable to forget. In the absence of these persistent reminders, and with the presence of a totally different environment, new channels of thought may be cultivated. In such an instance, as with the whistling habit, retroactive inhibition is deliberately practiced. New impressions are used to drown out the old.

(3) *Wearing the habit out.* Dunlap has suggested an extremely thought-provoking hypothesis. [15] He actually has had people practice their bad habits deliberately, and he claims success in breaking them up. This method has been applied to typing errors, stammering, nail biting, and similar nervous habits.

In stammering there are two major difficulties: lack of confidence and lack of voluntary control. Dunlap suggests allowing the stammerer to select the thing he can do, not what he cannot do. He is then asked to stammer all he can, instead of working to avoid it. Sentences are specially devised full of those sounds which give him the greatest amount of trouble. He is then told to go on a virtual stammering jag. Thus, he finds something he can do, regains confidence, and, most important of all, he begins to place his stammering on a voluntary basis. The last step, and the most crucial one, is to transfer this voluntary and confident control to everyday speech. Dunlap claims to have effected many cures in this manner, but he points out that amateurs should not try the method, since it requires a trained and thoroughly competent expert.

Muscular tics are controlled in much the same way. Suppose one has a certain twitch in the mouth or eyelids. He is told to move that muscle in the same manner several times successively; thus the muscular tension is worn off and relaxation follows for a period of time. The act is brought under voluntary control, and the subject pays deliberate attention to its elimination.

As to a critical evaluation of Dunlap's hypothesis, there is considerable debate. Primarily, the technique seems most pertinent when a habit of an emotional nature is involved. One would hardly think of breaking a drinking habit or a breach of manners by indulging freely (although young people who work in soda fountains are often told to help themselves, in the expectation that overindulgence will destroy interest). In such cases it would seem far simpler and more efficacious to exert will power and refrain from the habit, or to substitute a more desirable habit in its place. Some emotionally toned habits may wear themselves out; witness the rapid decline of interest in a piece of popular music that is heard too often.

CONCLUSIONS

There is no such thing as a poor memory. One who forgets rapidly or who cannot seem to remember things, simply did not learn them well. To remember well means to have learned well. One should pay careful attention when he has the first experience, and make active use of the material in order to remember it. Trick memory schemes are valuable only if they furnish logical meaning; the more farfetched they are the less economical their use. The chief value of the memory scheme is in the activity involved. Lack of attention explains the poor value of

incidental memory; where there is no intention to remember, attention is passive.

In certain cases one may wish to forget something or to get rid of what has been learned. Continued disuse will work in some cases, but if the habit is strong or is emotionally toned, it will be necessary to substitute a new habit. It may be possible to wear out a habit from frequent use, but it is doubtful if this will work except in special cases.

REFERENCES

1. Ballard, P. B. Obliviscence and reminiscence. *Brit. J. Psychol. Monogr.*, 1913, 1, No. 2.
2. Bartlett, F. C. Remembering. New York: The Macmillan Co., 1932. Chap. V.
3. Bean, C. H. The curve of forgetting. *Arch. Psychol.*, N. Y., 1912.
4. Book, W. F. The psychology of skill. New York: Gregg Publishing Co., 1925.
5. Borchard, E. M. Convicting the innocent. New York: Garden City Publishing Co., 1932.
6. Britt, S. H. Retroactive inhibition: a review of the literature. *Psychol. Bull.*, 1935, 32, 381-440.
7. Britt, S. H. The learning-remembering process. A reply to Professor Cason. *Psychol. Rev.*, 1937, 44, 462-470.
8. Britt, S. H. Theories of retroactive inhibition. *Psychol. Rev.*, 1936, 43, 207-216.
9. Burt, H. E. A further study of early childhood memory. *J. genet. Psychol.*, 1937, 50, 187-192.
10. Burt, H. E., & Dobell, E. M. The curve of forgetting for advertising material. *J. appl. Psychol.*, 1925, 9, 5-21.
11. Cason, H. The concepts of learning and memory. *Psychol. Rev.*, 1937, 44, 54-61.
12. Cason, H. The learning and retention of pleasant and unpleasant activities. *Arch. Psychol.*, N. Y., 1932, No. 134, pp. 30-38.
13. Crosland, H. R. A qualitative analysis of the process of forgetting. *Psychol. Monogr.*, 1921, 29, 1-59.
14. Dahl, A. Über den Einfluss des Schlafens auf das Wiedererkennen. *Psychol. Forsch.*, 1928, 11, 290-301.
15. Dunlap, K. Habits: their making and unmaking. New York: Liveright Publishing Corp., 1932.
16. Graves, E. A. The effect of sleep upon retention. *J. exp. Psychol.*, 1936, 19, 316-322.
17. Husband, R. W. Analysis of methods in human maze learning. *J. genet. Psychol.*, 1931, 39, 258-278.
18. James, W. Psychology, briefer course. New York: Henry Holt & Co., 1892.

19. Jenkins, J. G. Instruction as a factor in "incidental" learning. *Amer. J. Psychol.*, 1933, 45, 471-477.
20. Jenkins, J. G., & Dallenbach, K. M. Obliviscence during sleep and waking. *Amer. J. Psychol.*, 1924, 35, 605-612.
21. Kellogg, W. N. Some objections to Professor Cason's definition of learning. *Psychol. Rev.*, 1938, 45, 96-100.
22. Luh, C. W., & Liang, B. T. Further studies in forgetting and reminiscence. *Yenching Stud. Psychol.*, 1933, No. 3, 1-14.
23. McGeoch, G. O. The age factor in reminiscence: a comparative study of preschool children and college students. *J. genet. Psychol.*, 1935, 47, 98-120.
24. McGeoch, G. O. Whole-part problem. *Psychol. Bull.*, 1931, 28, 713-739.
25. McGeoch, J. A. The comparative retention values of a maze habit, of nonsense syllables, and of rational learning. *J. exp. Psychol.*, 1932, 15, 662-680.
26. McGeoch, J. A. Forgetting and the law of disuse. *Psychol. Rev.*, 1932, 39, 352-370.
27. McGeoch, J. A. The influence of four different interpolated activities upon retention. *J. exp. Psychol.*, 1931, 14, 400-413.
28. McGeoch, J. A. The influence of degree of learning upon retroactive inhibition. *Amer. J. Psychol.*, 1929, 41, 252-262.
29. McGeoch, J. A., & McDonald, W. T. Meaningful relation and retroactive inhibition. *Amer. J. Psychol.*, 1931, 43, 579-588.
30. McGeoch, J. A., & McGeoch, G. O. Studies in retroactive inhibition: X. The influence of similarity of meaning between lists of paired associates. *J. exp. Psychol.*, 1937, 21, 320-329.
31. McGeoch, J. A., & McKinney, F. Retroactive inhibition in the learning of poetry. *Amer. J. Psychol.*, 1934, 46, 19-33.
32. McGeoch, J. A., & McKinney, F. The susceptibility of prose to retroactive inhibition. *Amer. J. Psychol.*, 1934, 46, 429-436.
33. McKinney, F. Studies in the retention of interrupted learning activities. *J. comp. Psychol.*, 1935, 19, 265-296.
34. Meltzer, H. The present status of experimental studies on the relationship of feeling to memory. *Psychol. Rev.*, 1930, 37, 124-139.
35. Meltzer, H. Individual differences in forgetting pleasant and unpleasant experiences. *J. educ. Psychol.*, 1930, 21, 399-409.
36. Menzies, R. The comparative memory values of pleasant, unpleasant, and indifferent experiences. *J. exp. Psychol.*, 1935, 18, 267-279.
37. Morris, W. W. Story remembering among children. *J. soc. Psychol.*, 1939, 10, 489-502.
38. Murphy, G. General psychology. New York: Harper & Bros., 1933. P. 325.
39. Musatti, C. L. Oblio e arricchimento mnestico nelle deposizione testimoniali sopra fatti concreti. *Scritti onore Kiesow*, 1933, 42-52.

40. Pressey, S. L. *Psychology and the new education*. New York: Harper & Bros., 1934. P. 400.
41. Swift, E. J. *Psychology and the day's work*. New York: Charles Scribner's Sons, 1918.
42. Thisted, M. N., & Remmers, H. H. The effect of temporal set on learning. *J. appl. Psychol.*, 1932, 16, 257-268.
43. Titchener, E. B. Relearning after forty-six years. *Amer. J. Psychol.*, 1923, 34, 468-469.
44. Van Ormer, E. B. Retention after intervals of sleep and waking. *Arch. Psychol.*, N. Y., 1932, No. 137.
45. Warren, H. C. Two cases of long latent memory. *Psychol. Bull.*, 1918, 15, 207-209.
46. Waters, R. H., & Leeper, R. The relation of affective tone to the retention of experiences of daily life. *J. exp. Psychol.*, 1936, 19, 203-215.
47. Woodworth, R. S. The influence on retention of conditions favoring quickness of learning. *J. Phil.*, 1915, 12, 246.
48. Worcester, D. A. Retention after long periods. *J. educ. Psychol.*, 1928, 14, 113-114.

XXI

THINKING AND REASONING

1. The Nature of Thought

Thought is original mental activity during which new combinations are produced from sensations and items of information already possessed by the thinking person. A thought is not necessarily original or even novel. When we plan a vacation trip, we usually consult timetables or road maps; in short, we "think out" a trip suited to our interests, finances, and time. Although there may never have been a trip exactly like this one, the only *original* element in it was in planning the itinerary. We simply arrived at a new combination of already existing possibilities. Likewise, most new inventions are adaptations of previous discoveries in the same field.

Thought, like learning, involves both *insight* and *trial and error*. A problem may puzzle one for a long time, but in time the various elements fall into place and the problem that once seemed incapable of solution is solved. One group of psychologists has termed this problem solution situation "closure"; another psychologist calls it the "Aha!" experience. For instance, the most serious obstacle in the development of a mechanical cotton picker was to make the cotton adhere to the mechanical fingers. After the inventors had observed that the cotton fibers stuck to tools exposed to the early morning dew, it was a simple matter to install a device to moisten the mechanical fingers.

Trial and error is usually present to some extent even in mental processes of an advanced nature. We mull over possible solutions, discard some, tentatively accept several others, and finally select the best alternative. The discarded solutions were not all reprehensible or inefficient, but time was saved by discarding them while still in the

incubation stage. Here is a test that involves both trial and error and insight.

-CODE SOLUTION

The following list of words is composed of ranks of nobility, disguised in code, with another letter standing as a symbol for the true letter. We give you a hint. For example, if the words were states, the coded words might be identified by distinctive spellings; in Illinois the second and third letters would be alike and three letters the same. You are to work on this problem until you have all ten words deciphered.

Y	I	J	J	X						
V	D	N	X	O	J					
P	I	F	J							
F	N	X	L							
J	Q	D	T							
W	Q	D	E	X						
T	E	D	P							
U	Q	D	Y	I	N	Z				
U	Q	D	O	R	N	E	X	J	Z	Z
O	E	I	X	M	J	Z	Z			

There are at least two cues. In the first word the third and fourth letters are identical, and there are a total of five letters in the word. Hence "queen" must be the word. Next, two titles end in "JZZ," a combination which suggests the feminine ending "ess." With one or two words completed, one may use the newly found letters to assist in piecing together the remaining titles.

Code deciphering requires a similar combination of insight and trial and error. This ability has been developed to a high degree by such agencies as the Federal Bureau of Investigation. The most common letter or symbol is assumed to be "e" and the most common three-letter word is "the." But these hints remain tentative until they have been explored and they, of course, give little assistance if the message is brief.

Thought as a symbol. The greatest advantage of thought is the possibility of its expression through language, in which symbols are substituted for objects and actions. Travelers who have been forced to use sign language know how laborious and incomplete are such non-verbal modes of communication. It is much easier to say, "I'll take ham and eggs well done," than it is to draw a picture of the food and to convey by gestures how you wish it cooked. Through symbolic ability man enjoys his greatest advantage over animals, and through

development of that activity civilized man surpasses races that possess only a spoken language. The alphabet, simple as it is, has lifted *Homo sapiens* from the limitations of the Stone Age.

Language, written or spoken, not only increases complexity of thought processes, but it is also a great timesaver. Before we start to build a house we plan it on paper. We do not start to assemble it at random from a pile of boards, beams, shingles, and nails. Trial and error, if any, is on the mental level, and construction goes forward rapidly and economically. Without symbolic activity, however, we would be limited to physical trial and error with all the wastage of time, energy, and materials that entails.

2. Ways of Thinking

Thought is conducted in terms of images, words, and concepts, and in that order. Thought progression is from simple to complex.

(A) **IMAGES.** Think of the facial appearance of a close friend, the sound of a familiar melody, the taste of a favorite food, the feel of silk, or the strain of lifting a heavy suitcase from the floor. Such images are a necessary part of the thinking process. A painter or a composer has strongly developed visual or auditory imagery. Whereas a painter may require only a minute or two to catch the details of a particular landscape, the painting itself may take weeks to complete. The composer must have an image of the sound of each instrument of the orchestra before he can blend them in a symphonic work. An expert diver usually poises for a moment on the springboard to get an image of the dive before it is begun. He starts the dive when he "feels" himself go through it satisfactorily. Imagery often surpasses words in conveying meaning. Advertisers say, "One picture is worth a thousand words," because they know that people derive a much clearer impression from a picture of an automobile or a summer resort than from columns of verbal description.

(B) **WORDS.** Words are used in preparing speeches and letters, in making plans, in enumerating points for and against a proposition, and in thousands of other ways. When a person writes an important letter, he chooses the words carefully and constructs a sentence mentally before putting it down on paper. Even in connection with motor skills, words are used. Before taking a golf stroke one may say to himself, "I must keep my head down, my left elbow straight."

(C) **CONCEPTS.** Concepts are symbolic generalizations devoid of the concrete associations that characterize images and words. If a person says to himself the name of his college or his home town, he does not get a single image but a widespread network of associations.

He does not think of the college as a collection of buildings or athletic events or social diversions or friends, but as a composite of all these and many other impressions, all fused into a large concept. In fact, the idea of concept is difficult to explain by means of images and words alone. Like ideas of gravity, space, and relativity—all concepts of widest importance to modern man—the idea of concept itself must be understood conceptually. Words and images shadow forth the essential idea but vaguely.

3. Language and Thought

Most thinking occurs in the form of words. Words are the first elements of language we learn, and they remain the predominant element in our thinking processes. This conclusion is based largely upon genetic evidence in connection with the development of language and thought. [14] In preschool children there is little difference between thinking, speaking, and doing. Watch a child of three at play. He talks to his toys as if they were live companions, he makes observations about their habits, and he often acts various parts like a ventriloquist in a puppet show.

Adults do not ordinarily think aloud in this manner. Somewhere in the course of their development a transition has been effected. Before he reaches school age the child goes into an intermediate stage of whispering. His lips move, faint sounds are heard, but he is no longer talking as if to another person. Finally, his thinking goes on without external manifestations. We then say that he has passed from the *explicit* to the *implicit* stage of thinking. In the first stage thought and speech are virtually synonymous, while in the implicit stage the child's thoughts are confined to himself and they cannot be heard, recorded, or detected by an observer.

Just when and how completely this transition occurs varies greatly with the individual. First-grade children find it difficult to read silently. They are even surprised when the teacher tells them not to blurt out every thought that comes to them. On the other hand, many adults cannot think silently. Persons of limited intelligence cannot read a newspaper without moving their lips. This practice may be observed frequently on city streetcars. If reading ability is poor, it is necessary to spell out words and whisper them to oneself. Some college students move their lips and make sounds as they read. "S" sounds particularly may be heard in almost any library reading room if one listens attentively. Inefficient readers—and moving the lips is a sign of poor ability—usually receive low grades in college.

Among superior adults the transition is complete, or virtually so.

Of course, they use words in thinking about difficult material, in writing a speech or an essay on a technical subject. But in reading non-technical prose the speech musculature of the superior adult does not form words. If it did, he could not use his mouth and throat for other things, and we know that people smoke pipes, eat, whistle, and sing while they are thinking. [7] Furthermore, thought moves with extreme rapidity. In thinking about the past year a multitude of high lights may come and go within a few seconds. One word or idea may initiate a train of associations lasting but a few seconds, but it would take many minutes to explain the thoughts to another person and perhaps hours to write them. The device of recapitulation of a whole lifetime in a second that writers often use in stories of men drowning or doomed to the gallows is a case in point, although investigation has shown that the device is more convenient than true. [12]

One last bit of evidence concerning the relative independence of thought and language. It is a truism that a person does not become truly proficient in a foreign language until he transcends the necessity of translation in seeking the meaning of a passage. The expert linguist derives meaning directly from the new language, and is as familiar with it as with his native tongue.

What generalizations can be drawn from these data on language and thought? First, implicit thought grows out of spoken language. Second, as one grows mentally there is gradual transition toward an implicit and conceptual form of thinking. However, in difficult or technical thinking there is a slight regression to dependence upon speech. In summary, it is probable that thought is never entirely divorced from language.

Some psychologists believe that neither language nor thought can occur without at least a miniature muscular response. Slight vocal movements take place during abstract thinking, and they are evidenced by movements of the tongue and vocal cords and by changes in air column pressures. The thought of a single word may cause definite movements. Open your mouth wide and think of "bubble." Then try it again with the lips pressed together. Very often slight movements of the skeletal muscles accompany thought. For instance, if one thinks of sinking a screw into an oak plank, he might make a miniature movement of hand and forearm as if turning a screwdriver against strong resistance.

Can one learn or think *without* muscular movement? This was tested by inducing complete motor paralysis in cats by means of curare, a drug used by South American Indian tribes to kill animal and human enemies. [6] The muscles gradually become paralyzed until the res-

piratory system no longer functions and death comes from asphyxia. In this experiment the animals were kept alive in an "iron lung" until the effects of the poison wore off. In the meantime attempts were made to condition the cats. The experimenters used electrical shock as a native stimulus to produce withdrawal, and they attempted to associate the shock with the sound of a buzzer. Under paralysis the animal could not flee, but if an association was formed after recovery it would seek to avoid the shock when the buzzer was sounded. Although thirty trials were given, no learning occurred in the skeletal muscles, though there was some pupillary conditioning. Animals in the normal state form this association in three or less repetitions. Even when they had thrown off the effects of the drug they did not learn any faster than totally unpracticed animals. These results suggest that motor response is necessary in learning. However, later studies of the same type demonstrated that the motor area had been paralyzed, a condition that necessarily precludes the possibility of learning.

The same technique was used in a later experiment, but this time one of the leg muscles was isolated in such a way that the curare did not affect it. [4] This study produced conditioning that was effective during the curarized state but became ineffective when the animal returned to normal. When the animal was narcotized a second time the response returned. Thus, there was no change of response when the animal was in a normal state, but definite learning occurred in the drugged state.

In another study temporary inactivation of certain cortical areas was achieved by freezing with ethyl chloride. [5] The brain surfaces of five monkeys were exposed and several of the motor areas were paralyzed chemically. When paralysis was complete, conditioning trials were commenced. A bell was sounded for three seconds and during the last half second an electrical shock was administered. The experimenters wished to discover whether avoiding movements would occur after the motor paralysis had disappeared. The association was formed in all the monkeys and the movements did appear. These findings bolster the theory that muscular movements are not necessary in learning. Learning occurred without the possibility of motor response; hence it must have happened entirely within the cerebral cortex.

4. Development of Thought

As we have seen, thought and speech are virtually synonymous in the preschool child. Therefore, language usage furnishes an index to the growth of reasoning powers. Even memory is based upon language; in fact, it is probable that one cannot remember events occurring very

early in life because he lacked a vocabulary until he was three or four years of age. Without vocabulary and the ability to construct sentences the mental equipment necessary to thought and memory does not exist. On the other hand, the higher animals solve problems that require use of mental processes, and they, of course, are devoid of language.

Stages in the development of language and thought may be summarized in the following manner. [1]

(A) **COMMUNICATION WITHOUT WORDS.** Some meaning is conveyed by infants and animals without the use of words. These sounds may best be considered as expressions of emotion. A child cries if he is in pain, hungry, or merely lonely. The attention attracted by his crying provides the foundation for learning. At first he cries because he is uncomfortable; later he wails because he has come to expect a pleasurable result.

(B) **BABBLING STAGE.** The child of a few months gives vent to a great deal of random vocalization, and as a result produces almost every vowel and consonant sound. He makes a sound, hears it, likes it, and repeats it. This is called "circular imitation." The sounds are meaningless as far as true communication is concerned, but they provide a basis for the acquisition of learning. Syllables such as ma-ma and da-da are babbled more frequently than others. Fond parents interpret these sounds to refer to themselves, they use them, and they build up the associations that result in the first two words of the child's vocabulary. When friends visit such parents they are sometimes at a loss to know which is in the babbling stage, child or parents.

(C) **ONE-WORD SENTENCE.** About the age of fifteen to eighteen months definite words are used meaningfully. Each represents a complete thought. The child yells from his nursery: "Water!" He really means "I want some water, and you bring it right away!" The single word implies noun, verb, pronoun, and modifiers.

(D) **TWO-WORD SENTENCE.** The first words are largely nouns; next verbs are added. Now we have both object and action.

Beyond this it is virtually impossible to trace the growth of the simple declarative sentence, since there is considerable variation. One further stage worthy of mention is that pronouns, not used much before three years, represent a distinct stage in the development of thought, since they show that the child understands distinctions among individuals. He uses "you" and "I" instead of "Daddy" and "Peter."

(E) **SUBORDINATE CLAUSES.** Subordinate clauses, appearing at about seven years, indicate another qualitative development. The child demonstrates an appreciation of contingencies. Instead of the absolute "Let's go swimming," he says, "Let's go swimming if the sun is

shining." An adult demonstrates greater understanding when he admits possible exceptions. We say, for example, that intelligence in children is roughly equal to that of the parents, but that in some cases offspring show wide departures.

(F) APPRECIATION OF CAUSE AND EFFECT. Appreciation of cause and effect grows through several stages. According to Piaget, an eminent Swiss child psychologist, the age of eight furnishes an important dividing point in the maturation of thinking abilities. [9] Before this age little logical justification is employed. Authority is cited or a weak reason is assigned. Examples: "Daddy said it was so," or, "It was in the paper," or simply, "Because." The child is not yet capable of explaining that a river flows in a certain direction because water flows downhill, and that the mouth of a river is lower than its source.

(G) EGOCENTRISM. Egocentrism characterizes much of the thinking of children under eight. [9] They think of things chiefly in reference to themselves, their pleasures and preoccupations. Objectivity has not yet been attained. A typical error of this type is shown when a child ignores himself in making a count. He has one brother, but he does not realize that there are two sons in the family or that his brother in turn has a brother. He also fails to realize that the right-left relationships of a boy facing him are reversed, even though a child of five can differentiate between his own right and left hand. Another manifestation of egocentrism is failure to work with others. Up to five, the child usually plays alone. During the next two or three years he plays and talks with others, but usually not in a cooperative manner. He talks more for himself than for his hearers (as do some adults). At eight there begins to be genuine social interchange.

(H) REASONING AND GENERALIZATION. Relatively simple tests can be passed at the age of eight, as evidenced by their being placed at that level in the revised Stanford-Binet tests. [13] Here is one typical problem: "Edith is fairer than Suzanne; Edith is darker than Lili. Which is the darkest of the three, Edith, Suzanne, or Lili?" Another: "What is foolish about this: A man said, 'I know a road from my house to the city which is downhill all the way to the city and downhill all the way home?'"

Until a child is ten he does not ordinarily understand part-whole relationships. Younger children are unable to conceive of themselves as being in two geographical locations at the same time. A person may live in Chicago but not in Illinois, for you cannot be in two places coincidentally. The child may seem to be close to the truth when he admits that Illinois is larger than Chicago, but he rarely makes the final step in the analysis.

The next forward step comes at a mental age of eleven. Then the child sees common elements in a number of things. He recognizes that horses, pigs, and cats are all quadrupeds, but he knows that a four-legged table is not in the same class of things. He also begins to realize that cause and effect do not necessarily operate in both directions. Dynamite causes an explosion, but every explosion is not caused by dynamite.

The adult generalizes somewhat as follows: He sees a group eating lunch or seated around a conference table, and he wonders what organization that might be. He says to himself, "Jones is interested in fishing, is a graduate of Yale, and is associated with community charities. Do the others have any of these same interests? Oh, yes, several of the others are fishing enthusiasts, but none of them except Jones is a Yale man or is involved in community welfare work. So it must be a meeting of a fishing club." Thus, he has sought similarities and discarded possibilities which have proved not to be general.

A final step in the maturing of thought is the ability to carry on consecutive reasoning, step by step. Given a certain fact, this must follow, hence that is true, and so on. The test for superior adults contains a more difficult problem involving interpretation of proverbs. This type of item has been found to be excellent in differentiating between the average and the very bright, since it demands abstraction of fundamental meaning. This is part of the test with instructions. [13]

Here is a proverb, and you are supposed to tell what it means. For example, this proverb, "Large oaks from little acorns grow," means that great things may have small beginnings. What does this one mean?—"The mouse that has but one hole is easily taken." Or—"You must not throw pearls before swine."¹

5. Imagination

The degree of imagination present in any given thought process may vary within wide limits. It may range from a routine decision of whether to go to the early or the late movie show, all the way to the opposite extreme characterized by the bizarre fantasies of the paranoiac or the hebephrenic. Constructive thought is usually confined by certain objective realities. The inventor must have a lively imagination, yet to be successful he must be cognizant of physical laws and commercial practicabilities. He cannot transcend the law of gravity nor can he ignore the fact of friction. The poet lives in the domain of the imagination, but if his work is to be read he must use language as skillfully as a

¹Terman, L. M., & Merrill, M. A. *Measuring intelligence*. Boston: Houghton Mifflin Co., 1937.

wood carver employs his material. The poet must know human nature as well as the laws of metrics.

Day-dreaming occurs when the imagination is not restrained. In an extreme form it takes the shape of wish fulfillment, fantasy thinking, and brooding. Pathological liars and frustrated people generally tend to day-dream, since through unreality they achieve satisfactions denied them in actual life. Although day-dreaming is common in normal people, its excess denotes a flight from reality and its continued practice is a dangerous symptom of maladjustment.

It is, of course, impossible to say where thought ends and imagination begins, and where imagination wanders off into day-dreaming. Usually, however, thought is close to reality, imagination conceals to some extent the harshness of everyday life and day-dreaming substitutes an impossible dream world for the real one.

6. Problem Solution

(A) **STEPS IN PROBLEM SOLUTION.** There are four major steps in problem solution:

1. Recognition of the problem and a desire to solve it;
2. Reflection concerning various possible solutions;
3. Selection of the correct solution;
4. Polishing up the details.

(1) *Recognizing the need* for the solution of a problem in itself requires imagination and initiative. A humorist has suggested that most inventions have been motivated by laziness: automobiles to avoid walking or caring for a horse, telephones to obviate the necessity of traveling in person, electric lights to save the trouble of caring for oil lamps, and washing machines to ease the backs of housewives. Whatever the truth of this theory, complacent peoples do not advance rapidly in mechanical improvements, and American machines are the marvel of the Western world. Some people call us gadget-crazy and machine-mad.

(2) *Reflection concerning various possible solutions* is the next step. Let us say that we are driving to the next town to keep an appointment and that we have motor trouble on the way. Since we haven't the time to go to a farmhouse and call a garage, we attempt to diagnose the trouble and repair the difficulty ourselves. In an effort to minimize trial and error we recall previous instances when we had trouble. We may ask ourselves several questions. Have we run out of gas? Is the clutch slipping? Might the axle be broken? Might a fuse have blown? We eliminate one possibility of trouble after another. We got ten gallons of gas yesterday. Since the motor will not run, we eliminate

the clutch and axle possibilities. Since the lights light and the horn blows, the fuse is all right. Wait a minute! The motor sputtered before it stopped; maybe the gasoline feed system is out of order. This rapid series of thoughts has narrowed our search to a few possibilities: water in the gas, a clogged fuel line, something stuck in the carburetor. Trial and error will probably enter into the final check, but it has been considerably restricted.

(3) *Selection of the correct solution* is the culmination of the preceding step. There may be a sudden flash of insight when we realize that our solution hits the bull's-eye. Or we may have to wait until each possible solution has been subjected to experimental verification. As one writer put it, "The first thing is to invent a system; the second is to be disgusted with it."

Scientists usually employ the method of experimentation to verify or disprove an hypothesis. And a possible solution is an hypothesis until it has been weighed in terms of the evidence. If the solution satisfies all the tests and there is no contradictory evidence, it is accepted as a true solution. If much, but not all, of the evidence is favorable, the hypothesis may be retained and tentative conclusions may be drawn, but they should definitely be labeled "tentative."

One should not be chagrined when an hypothesis is found to be incorrect. True scientists operate without prejudice and are not afraid to admit that a certain line of research that has perhaps occupied them for months has been unsuccessful. Hundreds of compounds are made in a laboratory before the proper combination of drugs is found to counteract a certain disease.

Scientific reasoning notes similarities and forms generalizations based upon them. Bits of evidence that converge from various directions strengthen an hypothesis. In fact, the more varied the sources the sounder the conclusion is likely to be. For example, if we found a certain behavior trait in people from both civilized and backward countries, hot and cold climates, and Eastern and Western cultures, we would be more inclined to regard it as a native trait than if it were present merely (to our knowledge) among a million people living in one city.

(4) *Polishing up minor details* is the last step in the process of reasoning. This step occurs both in scientific reasoning and in perfecting a mechanical appliance. If a theory seems to have exceptions, we study these exceptions and generalize concerning their appearance. Then we may modify the theory in some such manner as this: Whole learning is generally more efficient than part, but with animals, young children, inexperienced learners, and with nonsense material, part learn-

ing may prove better. In the case of an invention there may remain one or two stumbling blocks to be cleared up. For example, when radios operating on house current were first replacing battery sets, a slight hum in the new sets interfered with enjoyment of music. The new devices could not be considered perfected until this hum had been eliminated.

The story of the inventor of a new process for making soap chips illustrates Steps 3 and 4. One day while shaving he accidentally ran across a new method for making light soap chips when he let his shaving soap dry on his face while he read an absorbing newspaper article. A man of lesser insight might have failed to associate dried soap on the face with a desired improvement in soap chips. He recognized opportunity when it presented itself; doubtless many others had had shaving soap dry on their faces without regarding it as anything but an annoyance. The last step was to devise a practical way of utilizing his discovery. Obviously soap could not be dried in wholesale lots on human faces, so the belt procedure was devised. But the practical application was unimportant in comparison with the original flash of insight.

7. Invention

Thinking, reasoning, and imagining occur in their most complex forms in invention. Not only is the thought original to the thinker, but to all mankind as well.

Fundamentally, invention is no different from any other type of problem solution. One recognizes a need, casts about for possible solutions, selects one, evaluates, criticizes, and revises it, and polishes up the final results. Our principal interest here centers about the particular act of creation.

This brings up the old problem of "inspiration." It is unfortunate that this concept has been so overworked in fiction that many people believe this is the way most discoveries occur. The truth is, as one scientist put it bluntly, "Genius is 1 per cent inspiration and 99 per cent perspiration."

Perseverance was called the most important characteristic by 700 inventors; it was named two and a half times as frequently as any other trait. Their list follows.

Creation is always deliberate. The artist, musician, poet, or inventor who lolls about waiting for a great inspiration rarely gets one. A friend of the author's, a free-lance writer, always tells young hopefuls, "Success in writing requires the application of the seat of the pants to the seat of the chair." The flash of insight that comes suddenly, perhaps in a moment of relaxation, is the final result of a

TABLE 41
MOST IMPORTANT CHARACTERISTICS OF INVENTORS [10]

Perseverance	503
Imagination	207
Knowledge and memory	183
Business ability	162
Originality	151
Common sense	134
Analytic ability	113
Self-confidence	96
Keen observation	61
Mechanical ability	41

great deal of thought. The more information you have at your disposal the greater your chance of arriving at the desired result, whether in painting or in cost accounting. Past experiences, the findings of specialists in a field, and self-criticism are valuable adjuncts to the creative process.

John Philip Sousa once said that the melody of "Stars and Stripes Forever" flashed into his mind while he was on an ocean liner. He worked out the whole march on the boat and transcribed it when he landed. Most compositions, however, like most artistic creations, are produced with a definite market in mind; in fact, they are sometimes produced to order. When musicians were supported exclusively by wealthy patrons, they were expected to produce original works regularly. Many novelists work longer hours at their desks than successful businessmen.

8. Categories of Thought

A person's thoughts tend to flow in certain well-established channels. Certain artists draw all their pretty girls alike, certain composers have similarities of melody running through many of their pieces, and most writers have characteristic styles. A student once commented, "Some-day I am going to buy a trombone and learn to play Wagner's music." He had noted that Wagner's music contained a large number of passages favoring that instrument. A painting by Thomas Benton or Vincent Van Gogh may easily be identified by characteristic colors and settings. Disputes concerning authorship are often settled by comparing the work with another by the same author. The famous controversy over Francis Bacon's supposed authorship of Shakespeare's plays has been pretty well decided in the latter's favor by comparing the choice of words in the admittedly authentic works of both authors.

This problem of the categorization of thought was tested by play-

ing records of little known works of composers of French, Italian, German, and Russian birth. [11] College students, most of them untrained in music, were asked to guess the nationality of the composer, and to omit any pieces they might have known previously. The judgments in all cases, especially the Russian, were better than chance. This fact lends credence to the theory that a composer cannot avoid introducing some aspect of the national character in his music. Italian music tends to be light and airy, German heavy and philosophic, Russian somber and gloomy.

The following passage illustrates in a non-technical way how thought processes are channelized by environment and personal experiences. An American trader was trying to describe America to a native woman who had always lived on a small South Sea Island. [3]

“. . . the wonders of America: its vast plains, its mountains, the mighty lakes and rivers, and the great highways stretching from coast to coast. ‘Just think, Mama,’ I said, ‘if you were to start walking from the Pacific Ocean across America and could keep going day and night, it would take months to reach the Atlantic Ocean!’

“‘You mean, if you were to paddle across,’ said Mama.

“‘No,’ I said, ‘walk.’

“‘But that’s foolish! You couldn’t walk across the lagoon.’

“‘I’ve said nothing about a lagoon.’

“‘But how could you cross an island without crossing the lagoon, unless you followed the reef, and that’s not walking across it but around it.’

“Mama, never having seen any land but a coral atoll, could not conceive of an island without a lagoon; and of course, to her, America was nothing more than an atoll somewhat larger than Puka-Puka. For a long time I tried to explain, saying that there were mountains and plains where the lagoon should be; but she would always break in with the question: ‘But where is the lagoon, then?’ ”²

9. Scientific Reasoning

Scientific reasoning is not fundamentally different from any other type, and it is by no means free of error. If fewer blunders are made in scientific works, it may be because scientists are less subject to prejudice, more aware of possible errors, and more inclined to weigh evidence carefully. Even so, the pathway of science is plentifully strewn with the carcasses of once-accepted theories.

We shall point out briefly several aspects of scientific reasoning that are pertinent to psychology.

²Frisbie, R. D. *The book of Puka-Puka*. New York: D. Appleton-Century Co., 1929, p. 342.

(A) **ADEQUATE SAMPLING.** Although we know that we should not generalize from a single case, the temptation sometimes overcomes our better judgment. In psychology we cannot arrive at an indisputable conclusion until we have tested a large number of people. The nature of the experiment governs the number needed. In testing simple functions, such as sensory or motor processes, individual differences are small and perhaps ten to twenty subjects may be adequate. But in tests involving such complex functions as personality, intelligence, or learning, it may be necessary to test several thousand persons before we can be certain that the results are characteristic. If there were a predominance of exceptionally good or exceptionally poor subjects, atypical averages would be produced and the experiment would be worthless. When a large group is tested, however, such fluctuations are forestalled.

The experimental group must also be properly selected. It has been suggested that much of the experimental evidence in psychology is not thoroughly typical, but is actually the psychology of the college sophomore, since he has been the subject in many of these experiments. He is about twenty years old, brighter than average, has already had more than an average amount of education, and is usually from an upper- or middle-class home. To obtain completely typical results, we should test people of all ages, abilities, educational levels, environments, occupations, and family backgrounds. This was clearly shown when the no longer published *Literary Digest* pre-election poll of several million voters went far astray in its prediction. Apparently this poll missed the lower economic brackets, virtually all members of which voted for one party. At the same time, another sample of five thousand (the Gallup poll) was much better selected, and its results foreshadowed the actual votes of fifty million citizens.

(B) **EVERY SCRAP OF EVIDENCE MUST BE ACCEPTED.** While science, truth, and democracy are said to go hand in hand, there is at least one major difference. Scientific disputes are not settled by votes between scientists. One well-conducted investigation may outweigh a hundred not so rigidly performed. Hence we cannot summarily brush aside a few experiments which show results divergent from the majority. Perhaps the majority is wrong and the minority right.

(C) **EVIDENCE MUST BE CLEAR-CUT.** If one is to reach a clear-cut conclusion, the evidence must be clear-cut. Unfortunately there are so many variables in the relationships among people that single causes for many acts cannot be isolated. Therefore, we must compromise in two ways. First, we may have to admit exceptions to the general rule. For instance, the law of frequency generally applies, but in certain situations deterioration rather than improvement follows practice. Students of

high intelligence usually do well in college, but occasionally one fails for reasons other than lack of ability. Second, we may assign proportional values to a general proposition. Intelligence is not a choice of heredity *or* environment. Rather, our task is to discover how much weight should be assigned to each of these factors.

(D) VARIABLES MUST BE CONTROLLED OR HELD CONSTANT. In order to determine causation, as many variables as possible should be eliminated. Since we cannot ignore the contents of a subject's stomach in an experiment employing drugs, each subject is given the same amount of the same food and is tested at the same interval after eating. Subjects of the same sex, age, weight, and physical condition are used. This precaution is especially important if the quantity of dosage is varied. In certain experiments there is a possibility of suggestion on the part of the experimenter, and that must be rigidly controlled. The subject should not be told the purpose of the experiment, lest he unconsciously assist the experimenter to verify his hypothesis. In memory tests, subjects are instructed to memorize certain material, but they are not told that a later test will be given. In experiments employing drugs the purpose cannot be concealed, but the drug may be given in a capsule. Half the subjects swallow a capsule that contains a neutral substance. The latter form a control group. This precaution was shown to be necessary in an experiment on the effects of alcohol. Several subjects were given near-beer (less than $\frac{1}{2}$ of 1 per cent alcohol), but since they were under the impression that it was real beer, they became hilarious.

While the experiment is going on, it is essential that each subject receive identical treatment. The same instructions must be given to each person, and it is customary to read or to have the subject read typed instructions. If instructions are given informally, the experimenter tends to give more or fewer from time to time, and this change may affect the time required for the subject to adapt himself to the task.

It is obvious that a carefully controlled experiment is less open to attack than one that does not follow strictly scientific procedure. An outstanding example of careful experimentation was Pasteur's famous research on rabies that led to many types of human and animal inoculation against disease. Since his ideas violated accepted tradition, he was bitterly attacked by the tradition-bound scientists of his day. Yet his work was so thoroughly controlled in all particulars, including the use of control animals as well as inoculated groups, that not the slightest flaw could be detected. Less perfect work, even though essentially correct, might have been discredited because of the widespread opposition his experiments aroused.

10. Errors in Thinking

Examples of faulty thinking are so plentiful that we can list here only a few of the commonest pitfalls. If a person applies these principles to his own thinking, he may avoid many inadequate and erroneous conclusions. Some errors involve the way arguments are devised, and some involve the facts and treatment of them. We shall mention a few prominent samples of each. [2, 8]

(A) **FAULTY INFERENCES.** Among logicians this is termed "non sequitur," a Latin phrase which means literally "it does not follow." Here we have an incorrect and a correct example.

- Case 1.* Mongolians have slanting eyes;
A has slanting eyes;
Therefore A is a Mongolian.
- Case 2.* Mongolians have slanting eyes;
A is a Mongolian;
Therefore A has slanting eyes.

In Case 1, to make certain that A is a Mongolian, one would have to expand the first line to "None but Mongolians have slanting eyes."

In some cases the data presented permit a conclusion; at other times one cannot justly form one.

- Case 3.* I am heavier than John; John is heavier than Harry.
Am I heavier than Harry?
- Case 4.* I am heavier than John; Harry also is heavier than John.
Am I heavier than Harry?

The question in Case 3 can be answered; that in Case 4 cannot.

(B) **ASSUMING SEQUENCE DEMONSTRATES CAUSATION.** This also has been given a Latin phrase, "Post hoc, ergo propter hoc," meaning "following this, therefore on account of this." This error is exhibited frequently in political arguments. "Since I have been in office the country (or state, or city) has enjoyed unusual prosperity. Therefore I deserve to be re-elected," or, "The opposing party was in power during the depression. Therefore they are responsible for it," or, "I took this medicine and two days later I was well."

(C) **HASTY GENERALIZATION.** Here the fallacies are in the contents (materials) rather than in the way they are set up.

All great businessmen began with small salaries. I began with a small salary, so I shall become a great businessman.

Students who really understand the material are confident in examinations. John is very confident; therefore he knows the material thoroughly.

You greatly admire Abraham Lincoln, one of the founders of the Republican party, so why should you think of voting for any other than a Republican candidate?

Joe is a member of Blank fraternity, which has a poor scholarship record. Therefore we know that his grades are below average.

The error in each of these is too obvious to need special comment.

(D) **FAILURE TO ACCEPT EVIDENCE.** Wish fulfillment and prejudice tend to create logic-tight compartments. Characteristic of this error is the statement prefaced by, "I still believe . . ." A prominent and well-liked businessman was found to have engaged in shady business deals for years, to have falsified his income tax returns, and to have juggled his books to cheat his partners; yet many people reject the overwhelming evidence of his crookedness and think of him as a persecuted saint. Occasionally an unscrupulous manufacturer gambles upon this human weakness by buying out a well-established brand of merchandise. He then substitutes inferior goods and reaps big profits. People do not discontinue their patronage for a long time because they have confidence in the label.

Negative evidence must be accepted as well as evidence that supports one's hypothesis. For example, when a person's dream foretells a catastrophe, newspapers all over the country report the coincidence. But millions of people have dreams that are not fulfilled, and these are forgotten. Much fatalistic talk is based upon failure to include negative instances, such as, "Every time I wash the car it rains within twenty-four hours," and, "I always drop gravy on a clean shirt." Little attention is paid to a drop of gravy on old clothes, or rain on an already dirty car.

(E) **APPEALS TO EMOTION.** Conviction of suspected criminals is secured more often by emotional appeals than by cold, hard facts. Advertisers attempt to sell goods through appeals to desires and fears rather than through scientific proofs of quality and economy.* Political candidates are occasionally discredited because they come from farm states, belong to certain churches or races, drive expensive cars, or have unconventional opinions.

Beware of appeals based upon flattery, prestige, and prejudice. For instance, I have heard this statement: "All intelligent men are joining this club. You don't want to line yourself up with stupid people, do you?" After the World War this argument was heard: "The United

*Let us not delude ourselves or be naïve. Salesmen and advertisers use emotional appeals because they know buyers are motivated by them. But we should not pull the wool over our own eyes. When we are buyers we should keep our eyes open and be on guard against specious arguments.

States should join the League of Nations. Germany and Mexico are the only nations not in. We don't want to be classed with them." Some arguments attempt to convince a person by threatening him with lowered status. The statement, "Of course, you're not stupid enough to believe that," means that the speaker thinks you are stupid. This type of argument is a potent weapon to induce conformity.

SUMMARY

Thinking involves making new combinations as well as devising original solutions. Thinking is closely linked to language in that both are symbolic in character, that is, both are substitutes for direct action. Insight and trial and error are present in thought as well as in learning.

Thought is developed through speech. The young child speaks and acts his thoughts. Gradually there is a lessening of overt behavior, and thinking becomes more implicit. Whether the transition is ever entirely made is problematical. In growing children, adults of mediocre ability and scanty education, and in people with poor reading habits, whispering and lip movements persist.

The quality and complexity of thought develop through a number of characteristic stages. Babbling and emotional cries precede the appearance of language proper. The first speech usually consists of a noun used with the meaning of a complete sentence; verbs are added a few months later. The introduction of subordinate clauses about the age of seven shows progress of thinking, because the child has learned to recognize departures from absolutes. Appreciation of cause and effect relationships develops between eight and eleven.

The higher mental processes involve various degrees of imagination and the exercise of various amounts of control. Thought itself need not be highly original; it is restricted to realities. Various levels of imagination are more or less censored by the thinker himself. Day-dreaming and fantasy thinking are characterized by an almost complete lack of censorship.

Invention and problem solution demand imagination, but they are backed up by knowledge, clear reasoning, and practicability. The major steps in such thinking are to recognize the problem, to reflect over the various possible solutions, to choose the correct solution, and to polish up the details. Insight is present in the second and third of these steps. The idea of fortuitous inspiration in invention or aesthetic creation has been much overworked; perseverance is much more important.

The chapter concluded with a discussion of accurate reasoning in which several common errors of logic pertaining to psychological

problems were mentioned, and with a caution against certain pitfalls. One should base his conclusions on a sufficient number of cases, accept all data, and control extraneous variables.

REFERENCES

1. Buhler, K. Les lois générales d'évolution dans le langage de l'enfant. *J. de Psychol.*, 1926, **23**, 597-607.
2. Burt, E. A. Principles and problems of right thinking. New York: Harper & Bros., 1931.
3. Frisbie, R. D. The book of Puka-Puka. New York: D. Appleton-Century Co., 1929. P. 342.
4. Girden, E., & Culler, E. Conditioned responses in curarized striate muscle in dogs. *J. comp. Psychol.*, 1937, **23**, 261-274.
5. Harlow, H. F., & Bromer, J. A. Effect of cortical motor paralysis upon conditioned emergency-flight responses in the monkey. In press (1940).
6. Harlow, H. F., & Stagner, R. Effects of complete striate muscle paralysis upon the learning process. *J. exp. Psychol.*, 1933, **16**, 283-294.
7. McDougall, W. The battle of behaviorism. New York: W. W. Norton & Co., Inc., 1929. A debate between Watson and McDougall.
8. Patterson, C. H. Principles of correct thinking. New York: Longmans, Green & Co., 1937.
9. Piaget, J. The language and thought of the child. New York: Harcourt, Brace & Co., 1927.
10. Rossman, J. The psychology of the inventor. Washington, D. C.: Inventors Publ. Co., 1931.
11. Stone, C. L. Identification of nationality in music. *Psychol. Bull.*, 1937, **35**, 756.
12. Swift, E. J. Psychology and the day's work. New York: Charles Scribner's Sons, 1925, p. 205.
13. Terman, L. M., & Merrill, M. A. Measuring intelligence. Boston: Houghton Mifflin Co., 1937.
14. Watson, J. B. Behaviorism. New York: W. W. Norton & Co., 1930, Chaps. X and XI.

XXII

UNCONSCIOUS AND AUTOMATIC PROCESSES

In this chapter we shall discuss several mental mechanisms which are at the fringe of consciousness and are under less control than are the processes of invention, problem solution, and creative thought.

1. Unconscious Processes

From time to time we have mentioned workings of the unconscious or the subconscious. Let us gather together some of their various manifestations.

The terms *subconscious* and *unconscious* have had almost as many uses as there are people who have written about them. Many writers, however, have used "unconscious" to refer to less accessible and more abnormal manifestations, such as amnesias and severe repressions. The subconscious is often used to apply to functions of which the individual is only dimly aware, which are nearly forgotten, or which one has great difficulty in recollecting.¹

(A) **REPRESSION.** Painful and conflicting experiences are incompatible with emotional balance and if they remain in consciousness will cause great mental conflict. Hence the contents of a complex may be repressed out of the conscious mind and relegated into the unconscious, but the force still persists and causes such symptoms as hysterical paralyses and anesthetics, lapses of memory, and dual personalities. We discussed several of these mechanisms in connection with mental hygiene.

(B) **EMOTIONAL HABITS,** such as prejudices, fears, and strong

¹The reader is urged to bear in mind that the unconscious and the subconscious are functions or processes. They are not to be thought of as entities or as localized in any particular areas of the nervous system.

annoyances are often due to survival of events which have long since disappeared from clear consciousness, and have possibly remained on a subconscious or unconscious level; but again they have as much or even more force than if they were still clearly conscious. Race and religious prejudices, and certain fears, are among the best examples of this. We have already noted that emotional memories are often far more enduring than is memory for more intellectual material; their effects may persist for years even though conscious recollection has long since vanished.

(C) SUBCONSCIOUS PERCEPTIONS AND JUDGMENTS. Subconscious perceptions and judgments have been described by a number of writers. Let us give an example of each. A girl related an incident in which she broke out into a cold sweat and trembled violently; afterwards she looked up and saw a snake coiled around the low-hanging limb of a tree. Whether this can properly be called subconscious or not, at least she was not definitely conscious of the snake before she experienced a reaction appropriate to potential danger. Overlearned acts may likewise be carried on at the fringe of consciousness. An absent-minded individual reported that he had driven his car from his home to his office without having any recollection of the three-mile journey. Apparently while he was thinking of something else he took all the correct turns, obeyed proper traffic signals, and steered clear of pedestrians and other cars. Likewise the expert baseball player is able through long experience to make judgments much faster than he could possibly decide deliberately. When the batted ball comes to him he must throw it without hesitation to the proper base.

It is believed that many of our spontaneous and apparently capricious thoughts are due to subconscious association. Perhaps you are walking down the street and there suddenly flashes into your mind some episode that took place several months previously. Why does such a memory arise so unaccountably? It is probable that some passer-by or some automobile or some object in a store window started a train of associations, and this partial stimulus served, possibly entirely subconsciously, to reinstate the whole of the original experience through a process of redintegration. All the intermediate steps were subconscious, or at least at the fringe of consciousness, and you were aware only of the end results.

Laboratory demonstration that a person may be unconscious both of the stimulus and of his own response to that stimulus was shown very clearly by Baker. [2] He actually succeeded in conditioning a pupillary response to an auditory stimulus presented by means of an earphone, but of such low intensity that the subject was not able to

tell when the stimulus occurred. Since an original, or unconditioned, stimulus is necessary in all conditioning, the contractions in size of the pupil were at first produced by a light flash. During the next stage of learning the two stimuli, visual and auditory, were presented together, and finally the pupil contracted when only the subliminal stimulus was sounded. This proves that it is possible to form an association between a stimulus of which the subject is unaware and a response that he cannot realize is occurring.

(D) THE "SUBCONSCIOUS" MAY BE UTILIZED TO REVIVE MEMORIES. We have all had the experience of vainly trying to recall some person's name or address, and then having it suddenly pop into our mind a few hours or days later. Although we are not consciously thinking of it, it is postulated that our subconscious mind must be milling it over. Whatever the mechanism, this phenomenon can be used in a very practical way. If you come to an impasse in trying to recollect something, let it go for a while and you may often recall it in the midst of another train of thought. Deliberate, conscious efforts to recall it will only create confusion, place obstacles in the way, and keep erroneous ideas in the foreground. Another practical application of the same technique can be made to written examinations. One should read all the questions through before starting to write on any. It will be best to write first on the question concerning which one has the greatest mass of immediately available information, thus allowing the subconscious to work over the other questions. It is often surprising to find how questions that at first inspection stumped one entirely are pretty well organized by the time one is ready to write on them a half hour or an hour later. On a true-false test where there may be fifty or a hundred questions one should first answer those about which he is sure, then on rereading the remaining ones he will find that many more have become straightened out in the interim. One should not place too much reliance upon this mechanism, however, as its uses have definite limits.

2. Mental Set

Mental set may be described as the direction of attention in advance of a stimulus. When listening to a musical selection a friend whispers, "Listen to the flute in the next passage," so we listen for that instrument especially and ignore the other instruments. Or you could be given a mental set when told to do one particular mathematical process, such as "Add these: 4 and 8; 9 and 6." "Now multiply 4 and 8, 9 and 6." One who has been reading pages of German prose may have developed such a strong set that he is puzzled by a word of English mixed in the passage. Learning and experience are very important in mental set.

If we say the word "ball" to a dancer, a baseball umpire, a tennis enthusiast, a tavernkeeper, and a boy playing in the snow, we will receive a different association from each.

Set may be emotional as well as intellectual. A grouchy person seems to be looking for any possible insult in the conversation of others, while a happy person derives the more favorable interpretation. A jury often deals with an accused person in terms of a set his past record has given them. If he has been a "bad egg" previously, there is less likelihood of an acquittal than if the same evidence concerns a man of previous good reputation. Much humor is derived from set; when a well-known comedian makes his first entrance a wave of laughter often sweeps over the audience before he has said a word. When Mark Twain in his later years tried occasionally to make a serious speech, the set of his audiences was such that they laughed at his most sober and serious observations.

Set is often responsible for a persistent error; one has to retrace one's steps in order to get back on the right track. A student in solving a correlation problem realized that he had made an error somewhere, but even half a dozen rechecks failed to disclose it. Finally he discovered that he had consistently failed to square a certain sum, and the failure had thrown off his whole calculation. One might try this conundrum on an unsuspecting friend to illustrate this principle:

Pronounce this word: McNab [spelling it out].
 Right. Now pronounce this: McCarthy.
 Fine. Now try McKenzie.
 Good. Now pronounce MacHinery.
 Wrong. In my experience that is machinery!

In constructive work it is often practical to maintain a set. For instance, in a simple experiment students were asked to add 6 to each of a column of two-place numbers, to subtract 3 from all the numbers in the second column, and to alternate in the third column, by adding 6 to the first, taking 3 from the second figure, adding 6 to the third, and so on. When alternation was demanded there was a loss of 34 per cent in terms of time required to complete the tasks. When the shift was between addition and multiplication the loss was 54 per cent over maintaining a constant set of either steady addition or steady multiplication. [10]

The practical implication of this demonstration is that it is better, where possible, to concentrate on any given activity a certain length of time before going on to the next. For instance, if one has to do a series of twenty mathematical problems, he might do the addition of all prob-

lems first, all multiplication in one series, all square root problems one after the other, and then wind up with the final solution of each problem. He will save time and be less prone to error than if he does each problem from beginning to end separately.

3. Hypnosis

(A) NATURE OF HYPNOSIS. The term is derived from Greek, and means "sleeplike." While under hypnosis the subject is in a condition of extreme concentration, is largely disorientated from his surroundings, and is in a condition of heightened suggestibility. This state shows some interesting and illustrative phenomena, although by itself it is of no great importance to psychology. [7]

(B) METHODS OF HYPNOTIZING. There are various methods of inducing hypnosis, but they all involve the same broad principles. [3, 4] The subject is seated in a comfortable reclining chair, in a dimly illuminated room. The operator suggests complete relaxation and inattention to outside cues; then he talks to the subject in a low-pitched, slow, and monotonous voice, somewhat as follows: "I want you to relax, and pay no attention to anything except my voice. Your hands and arms are like lead; you can't move them. Your eyelids are very heavy; you can't keep them up any more. You can't open your eyes; try it." (This is a test; if the subject can open his eyes, the operator knows that the trance has not taken effect as yet.) Such droning conversation continues until the operator is satisfied that the subject is in a light trance. Sometimes the subject is asked to look at a shiny object, such as a steel ball or a small mirror, held slightly above the normal line of vision. This imposes a slight strain on the eyes and keeps attention from wandering, but it is not at all necessary.

There are several levels of trance states. One investigator distinguished four main states. [5] (1) In the lightest trance the subject is not completely under, but his muscles are relaxed and he finds it difficult to open his eyes. The careful operator will rarely attempt to induce more than a light trance during the first session. The subject is usually nervous and unless he retains complete confidence in the operator, subsequent efforts may meet unconscious resistance. (2) In the next deeper state an anesthesia may be suggested; the subject will not flinch when gently pricked by a needle. A muscular rigidity, such as holding the arm out straight for minutes without apparent fatigue, can also be induced. (3) In the third level more exaggerated phenomena will appear. The kinesthetic delusion may be so strong that he will be unable to lift a watch from the table, even though he struggles as violently as if it were a grand piano. He may retain post-

hypnotic suggestions, such as opening a window five minutes after being awakened. (4) In the deepest, or somnambulistic trance, he will carry through bizarre suggestions, such as removing the necktie from a dignified professor, dancing with an imaginary girl, or seeing a rose grow out of the cement floor. Skin, taste, and temperature suggestions will be accepted. It may be suggested that he does not feel a pin, or that a smooth pencil rubbed over his forearm is a sharp razor. Plain water may be said to be milk or hot coffee. In all cases the subject's behavior matches the suggestion. He will also walk about and engage in conversation without disturbing the trance. Once a subject walked into my office, asked the date of the Battle of Waterloo (which I purposely answered with an erroneous figure to see if my word would be questioned), accepted the answer, and returned to relay the information to the operator.

After the operator has completed the demonstration, he arouses the subject by telling him to awaken after he has counted ten, after five minutes, or when the clock strikes the next hour. The person awakens as from normal sleep; he moves slightly, perhaps stretches, and gradually returns to consciousness.

(C) PRACTICAL USES OF HYPNOSIS. Today hypnosis is practiced more often as a stunt than for any practical purpose. But occasionally it has definite use.

(1) *Anesthetic*. About the year 1840 many operations were performed while the patient was under hypnosis. Many of these were in India, as one of the leading exponents of hypnotism was a doctor residing there. Here is a description of one case. [3]

The patient was sinking: she had been attacked with fever, and Dr. Esdaile, though he was not satisfied that she had been mesmerised sufficiently, determined to operate at once, as further delay endangered her life. The leg was taken off a little below the knee. . . . The thigh and knee from which the leg had been taken were perfectly motionless, and the only evidence of life was her respiration. She was not held or tied down in any way, and, during the whole operation, not the least movement or change in her limbs, body, or countenance took place. Dr. Esdaile left her to awake naturally, which she did in about a quarter of an hour. She then told us that she had a good and undisturbed sleep, without dreams or pain, and that she was ready to have her leg amputated. Upon receiving ocular demonstration that the operation had been performed her countenance expressed surprise and pleasure, and, as if doubtful of the fact, we observed her pass her hand over the stump, apparently to test the reality of what she saw.²

²Bramwell, J. M. *Hypnotism*. Philadelphia: J. B. Lippincott Co., 1930, p. 160.

It is quite possible that more use would have been made of hypnosis if ether and chloroform had not been discovered. Certain difficulties bar its widespread use, however. Since all persons are not susceptible to a deep trance upon the first attempt, the use of hypnotism in emergency cases is prevented. Not every doctor is a good operator, however, nor every patient a good subject.

(2) *Revival of memories* has been achieved in a trance state. [9] In Chapter XX we saw that interference causes the greater part of forgetting. Often when we try to recall a desired bit of information, a number of irrelevant scraps come up and become confused with each other. Under hypnosis, interference and loss of confidence disappear. People have recalled where they misplaced a valuable article, such as a watch or ring. Telephone numbers or historical dates, rusty from disuse, may be brought back by the same technique.

(3) *Curing neuroses or bad habits* may be assisted by hypnosis. Lost memories are revived, and a diagnosis of the true causes is made possible. Next, suggestions are made for post-hypnotic behavior. It may be suggested that the subject is not to be fearful of the dark or that he is not to brood about ill-health. Lackadaisical students have been known to study hard for hours after a trance. Unfortunately the duration of post-hypnotic suggestion is probably only a day or two at the most; hence the chief curative possibilities lie in making a break in habitual behavior and in hoping that this period will serve to build up confidence in the cure. A smoking habit might be broken by suggesting that the next cigarette will have a very unpleasant taste. A person may then stop smoking for a day or two, and find that the brief interruption has furnished the basis for a complete break.

(4) *Self-hypnosis* can be of practical value in "talking one's self into" doing something. It is really a matter of self-suggestion, much like the famous Coué formula, "Every day in every way I am getting better and better." Some people can put themselves to sleep by whispering, "I am getting drowsy; I am becoming thoroughly relaxed," and so on. This process will eliminate the thoughts which keep one tense and alert especially when worries are preventing sleep.

(D) MISCONCEPTIONS ABOUT HYPNOSIS. There are a number of fallacies about hypnosis concerning which the student of psychology should be warned.

(1) One cannot be forced to commit a crime while under hypnosis. We have fictional accounts of crimes done by a dupe in the hands of an unscrupulous operator or of sex offenses being committed against women in a trance. A suggestion distinctly contrary to one's code of ethics will wake him from the trance.

(2) A weak mind or weak personality is neither the cause nor the result of hypnosis. The operator does not have to be a brilliant or a dynamic personality. One study showed no significant correlations between intelligence score, introversion-extraversion, neurotic tendencies, and susceptibility to hypnosis. [5] In fact, the only positive trends were between intelligence and susceptibility, and between self-esteem or dominance and susceptibility, thus showing that those with better intellects and "strong" personalities actually made better, not poorer, subjects. Men and women (college students) were equally susceptible.

(3) A person can be hypnotized against his will only with the greatest difficulty, and usually not at all. In fact, a person who is rather timorous will probably not experience anything deeper than the lightest trance. The subject must be willing and confident.

(4) The subject will not remain under hypnosis indefinitely if the operator happens to leave. Several stories have been written about patients who remained in a state of suspended animation after the operator had died from a sudden heart attack. Actually, if left alone, the subject will awaken spontaneously in an hour or two, or sometimes he will drift into a natural sleep. Sometimes it is difficult to waken a subject, especially if he has injudiciously been put into a deep trance on his first experience, but there is nothing permanent to worry about.

(5) No superhuman feats are possible. Inaccurate accounts tell of novices playing a piano brilliantly or speaking Chinese fluently. Such behavior is not possible unless the individual possesses the requisite knowledge and capacities. It might be that a person who could play the piano well but was afraid to appear in public could be induced to rise to his best through hypnosis, but the skill has to be there. Usual capacity in feats of strength can be surpassed only through removal of resistance or by the suggestion that fatigue is not present.

(6) Finally, group hypnosis is possible only under certain special conditions. One lecturer claimed that he had placed a good share of an audience of several hundred in a trance, but they were simply paying close attention to his words and were quiet and peaceful. The situation is entirely different if it is a milling, noisy, and possibly antagonistic mob. A crowd, however, does show one aspect of hypnosis, a high degree of suggestibility.

4. Suggestion

Suggestion consists in producing uncritical acceptance of an idea, without argument or command. [7] A person is employing suggestion if he persuades children to play out of doors by observing in an apparently casual manner that it is a beautiful sunny day. Often such

indirect approaches work better than more direct attempts at motivation. For example, no man wishes to be told what girl to take to a dance, but he might be led to invite a certain girl if his friends connived to have him overhear how pretty and entertaining she was.

Suggestion may even produce physical changes. A physician will predict that the pain will begin to abate within a few hours (it would be ridiculous to say that it will disappear within five minutes) and that by tomorrow morning the patient will feel all right. Persons have cured headaches by taking aspirin tablets which later have been analyzed and found to contain no drug whatsoever. With less commendable purposes, practical jokers have been known to make a perfectly well person sick by arranging to have several people tell their intended victim how badly he is looking today.

Suggestion in a waking state has been compared with that in a hypnotic trance. Subjects in either state stood blindfolded and heard the experimenter say, "You are falling forward, you can't help yourself, you are falling forward, forward, forward," until they swayed so far forward that it was necessary to catch them by the shoulders. The average suggestion time for awake subjects was thirty seconds; those in a trance stood only twelve seconds before they toppled forward. This demonstrates both that a subject is unusually suggestible in the trance state, and that the average individual in the waking state is suggestible to some degree. [2]

Neurotic persons are said to be more suggestible than stable people. This is evidenced by imitation of methods of committing suicide or of certain types of crime. During one period of time or in one city there may be a wave of drownings, then of hanging deaths, then of suicide by poison. In one city a bridge spans a deep canyon. It has been called "Suicide Bridge," because nearly a hundred people have jumped from it. Recently police erected a high fence to prevent suicides, and experts are of the opinion that it will actually save lives, since people who have been planning to jump from the bridge will not take their lives in other ways. A woman who jumped from a pier returned to land when a patrolman threatened to shoot her. She was afraid to die by a bullet, but not by drowning. In one of our largest cities, successive waves of robbing hotels, moving picture ticket windows, and cigar stores have been observed. Sex offenses seem similarly to occur in waves. On the basis of such evidence a number of criminologists feel that crime would be reduced considerably if newspaper publicity were limited.

Sometimes negative suggestion is used to motivate a stubborn individual. To get such a person to play golf with you, you may tell him that you are playing that afternoon on a very tough course which only

the best players can negotiate. If he is particularly stubborn, you might add that the course is probably too difficult for his game. People have been persuaded to buy car A by discussing the merits of car B. Such people feel that their ability or judgment is being considered lightly, and they follow an opposite course to prove their determination and independence.

5. Dreams

Dreams are of fascinating nature, and they are so closely linked with daily life that we would like to know what causes them and what they mean.

(A) CHARACTERISTICS OF DREAMS. (1) *Absurdity and lack of criticism* is a chief characteristic of dreams. During the dream the associations may not appear absurd, but later when it is narrated it is readily seen to be nonsensical (at least superficially). Although we do not deny that dreams have more facile and farfetched associations than waking thoughts, at the same time it should be pointed out that they follow the same general laws as waking thought sequences. Occasionally one is partially critical toward a dream. A college man reported that he had dreamed of sitting beside the radio with the basketball coach listening to an out-of-town game, and in the dream he wondered why the coach had not accompanied the team. Usually, however, such incongruity would be accepted without question.

(2) *Amnesia* is a frequent characteristic. We have all tried to recall dreams and discovered that not even their general nature could be recalled. Even trying to collect dreams by keeping pencil and paper at the bedside often proves inadequate, since many are forgotten during sleep.

(3) *Imagery* is very strong in those dreams which do persist into waking consciousness. Visual imagery predominates, with auditory images the second most frequent. Taste, smell, temperature, and touch are seldom reported.

(4) The *speed of dreams* is a debated subject. But the evidence is convincing that they are extremely rapid. Persons have been awakened suddenly by a door slamming and have narrated complicated dreams which in actual life would require an hour or two. This rapidity may be compared to that of thought; one can think in a few minutes of the highlights of a three-hour automobile drive. It is hardly likely that one could have been dreaming and incorporated the sudden noise into the dream. For example, an alarm clock might both start and end a dream which has its climax in church bells ringing loudly.

(5) *Age*. The frequency and vividness of dreams decline with age, just as does the vividness of waking imagery. Children have the

greatest number and the most emotionally charged dreams, but as one passes the age of twenty-five they begin to decline in frequency and intensity.

(6) *Frequency*. The majority of college students report from several dreams a week to several a night. A few vary widely from these general limits.

(7) *Emotional content*. Many dreams are highly emotional. Some are pleasant, while some are distressing or even terrifying.

(8) *Recurrent dreams*, that is, the same dream occurring again and again, are experienced by many people. Their causes and meanings are unknown.

(B) CAUSES OF DREAMS. Let us accept Freud's hypothesis that dreams, confused as they may seem, have definite cause and meaning. [6] It is repugnant to a scientist to conceive of anything as entirely random and meaningless. There are three chief theories of the origin of dreams: they are holdovers from emotional experiences of the day; they are produced by external sensory impressions; and they express material which has been relegated to the unconscious. (We purposely omit the idea of prophecy, which has no substantiation beyond a few isolated hand-picked instances.)

(1) *Holdovers from daily experiences* make up a good many dreams, especially when there has been considerable emotional stress. Quarrels, upsetting episodes, and strong ambitions may produce dreams. Athletes frequently dream of tomorrow's contest, sometimes as heroes, sometimes as miserable failures. Such dreams have been compared with the "unfinished business" portion of a formal meeting. Events which have been concluded satisfactorily will drop out. It might be added that some apparently irrelevant dreams are caused by emotion, although they do not deal with exactly the same subject matter as the life situation which caused them.

(2) *Sensory impressions* may be transferred into dreams. Persons have dreamed of swimming in icy water or rolling in a snowbank and waked to find that their bedcoverings had fallen to the floor. Boards being clapped together have produced dreams of battle. Nightmares in which giants have pinned the dreamer's hands to his sides have been traced to the sheet becoming tightly wrapped about him as he turned in his sleep. A pinch on the neck caused one person to dream of himself as a boy, with the family doctor putting a plaster on his neck. A student dreamed that he was playing basketball, but in shooting a basket his left arm wouldn't coordinate with his right, and the shots refused to go straight. He woke up to find his left arm asleep from the elbow down.

(3) *Wish-fulfillment*. Desires which have failed to meet with expression during the day are often expressed during dreams. Some of these may deal with sex, some with other topics. Freud and his followers emphasize this theory. Other psychoanalysts lean toward this motivational idea, but emphasize different drives.

Just as with many other alternative theories which we have discussed in this book, there is undoubtedly truth to all three of these general causes of dreams. There is nothing mutually antagonistic about the three classes. The chief problem here is to classify each type of dream.

(C) *INTERPRETATION OF DREAMS*. Just what do dreams mean? Are they merely to be described, like the day-dream, as consisting in uncritical and random associations, or do they have definite underlying significance? Are they worth interpreting?

To Freud, the dream is the indirect or disguised expression of a repressed desire. Material which has been repressed into the unconscious, and hence is not normally available to the conscious mind, tends to come back in the less censored dream consciousness. But it does not come back in its original form. It is like an uninvited guest at a masquerade who is able to gain admittance only by wearing a disguise. It cannot be admitted in its original form, but in a different form it is able to slip by the *ensor*. In sleep the censor is somewhat off guard, and some material which has been relegated to the unconscious comes back. It must be disguised, however, since the censor is partially awake and will not admit the original material with all its emotional force. Therefore, we have to distinguish between the *manifest content*, the dream just as it appears, and the *latent content*, what the dream really means. This is done chiefly by means of a set of symbols which have standard interpretations. Dreams of objects of certain shapes represent the sex organs, various acts stand for sex relations, and certain other dreams give evidence of repression of various sexual functions.

Whether the underlying significance of the majority of dreams is sexual has been the subject of much dispute. Certainly many dreams are directly or indirectly based upon sex. There is good evidence of operation of the censor. Twenty-five college men were interviewed about dreams which dealt directly with sex. It was found that the girls involved were either casual acquaintances or total strangers. In this case the censor may be compared to conscience, which kept the men from having illicit thoughts, even in their dreams, about girls whom they knew and respected. [8]

Wish-fulfillment, apart from sex, plays a large part in dreams. Analysis of dreams of persons confined to prison has shown that many deal with escape, travel, and similar release from confinement. People

who have recently become crippled or invalided dream of themselves as sound and whole again.

Yet we all know that many dreams are highly unpleasant in content. They include such topics as death of self or close friend or relative, fear of bodily injury, fire, attack, drowning, torture, falling, smothering, and nudity. The Freudians account for some of them on the desire basis, to their own satisfaction at least. If one dreams that a certain person has died, it indicates, say the Freudians, he would really like to get rid of that person, even though for the sake of conscience and outward appearances he acts grief-stricken. Assault dreams on the part of women are supposed to represent true desires, worked out in such a way that the conscience would be clear. Possibly dreaming of nudity demonstrates a fundamental desire to show oneself off, but the censor demands that it be accompanied by shame before such a dream is allowed to appear even in dream consciousness. Yet, it is not possible by any stretch of the imagination to place some dreams on a wish-fulfillment basis. A householder during a cold spell dreamed several times during a single night of getting up and finding the furnace fire out. He could have no possible reason for wishing this. The nightmares of children often cause them to wake screaming, and they may be so realistic that they affect the mood for several hours during the day. Most of the dreams people wish to have explained are caused by events of emotional significance: quarrels, love worries, business troubles, impending athletic contests.

SUMMARY

Mental functions are not only carried on in clear consciousness; some are near or even beyond the fringe of waking consciousness. Such processes have been explained by some writers as occurring in the subconscious or in the unconscious mind. Highly unpleasant and painful experiences are said to have been actively forced from consciousness into the unconscious, and in the unconscious they become responsible for various abnormal manifestations. Material which is not repressed, but which is not readily available to waking consciousness, is sometimes assigned to the subconscious mind.

Hypnosis and suggestion are two states in which the subject is especially prone to accept uncritically ideas from an operator. Suggestion can be made to play a serviceable part in the practical use of psychology, but hypnosis at present is of doubtful practical use.

Dreams are assumed to be less critical than waking associative processes, but their course follows established psychological principles.

There are three main types of causes: emotional carryover from the day, transfer of external sensory impressions into dreams, and wish-fulfillment, that is, expression of repressions.

REFERENCES

1. Baker, L. E. The pupillary response conditioned to subliminal auditory stimuli. *Psychol. Monogr.*, 1938, **50**, No. 223.
2. Berreman, J. V., & Hilgard, E. R. The effects of personal heterosuggestion and two forms of autosuggestion upon postural movement. *J. soc. Psychol.*, 1936, **7**, 289-300.
3. Bramwell, J. M. Hypnotism. Philadelphia: J. B. Lippincott Co., 1930. P. 160.
4. Conklin, E. S. Principles of abnormal psychology. New York: Henry Holt & Co., Inc., 1927, Chapters XII, XV.
5. Davis, L. M., & Husband, R. W. A study of hypnotic susceptibility in relation to personality traits. *J. abnorm. (soc.) Psychol.*, 1931, **26**, 175-182.
6. Freud, S. The interpretation of dreams. New York: The Macmillan Co., 1913.
7. Hull, C. L. Hypnosis and suggestibility. New York: D. Appleton-Century Co., Inc., 1933.
8. Husband, R. W. Sex differences in dream contents. *J. abnorm. (soc.) Psychol.*, 1936, **30**, 513-521.
9. Huse, B. Does the hypnotic trance favor the recall of faint memories? *J. exp. Psychol.*, 1930, **13**, 519-529.
10. Jersild, A. T. Mental set and shift. *Arch. Psychol.*, N. Y., 1927, No. 89.

INDEX

INDEX OF AUTHORS

- Adler, A., 267, 268, 293
Alexander, H.B., 370, 379
Allport, F.H., 228, 235
Allport, G.W., 228, 235, 238, 256
Anastasi, A., 323, 337, 372, 379
Anderson, H.H., 147, 152
Angell, J.R., 119, 128
Austin, S.D.M., 424, 434
- Baker, H.J., 295
Baker, L.E., 490, 491, 502
Ballard, P.B., 452-454, 466
Baller, W.R., 356, 379
Bard, P., 177, 184
Bartlett, F.C., 443, 466
Bean, C.H., 437, 466
Bernard, L.L., 152
Bernreuter, R.G., 220, 235
Berreman, J.V., 497, 502
Best, C.H., 85, 128
Bills, A.G., 406-408, 434
Binet, A., 311, 312, 314, 321
Bingham, W.V., 310
Bird, C., 55, 66
Blanchard, P., 273, 283, 294, 295
Blodgett, H.C., 137, 138, 152
Bools, W.F., 407, 434, 439, 466
Borchard, E.M., 442, 466
Brainard, P.P., 28, 40
Bramwell, J.M., 493, 494, 502
Bridgman, D.S., 346, 348
Britt, S.H., 436, 444, 446, 466
Bromer, J.A., 474, 488
Brown, C.H., 180, 184
Brown, R.W., 58, 66
- Bruce, R.H., 137, 138, 153
Bryan, W.L., 406, 434
Bühler, K., 63, 66, 475, 488
Bunch, M.E., 148, 149, 153, 417, 434
Burks, B.S., 386, 398
Burt, E.A., 485, 488
Burt, H.E., 439, 459, 466
Byrd, H., 330, 337
Byrns, R., 368, 379
- Cannon, W.B., 177, 179, 184
Carlson, J.S., 253, 256
Carr, H.A., 104, 111
Cason, H., 412, 415, 417, 434, 435, 436, 448, 466
Cattell, J.M., 311, 379, 394, 398
Cole, L., 295
Conklin, E.S., 493, 494, 502
Cook, S.W., 253, 256
Coover, J.E., 17, 18
Cox, C.M., 357, 359, 379. *See also* Miles, C.C.
Crawford, M.P., 29, 30, 40, 145, 153
Crosland, H.R., 442, 466
Cruze, W.W., 55, 66
Culler, E.A., 474, 488
Curti, M.W., 46, 66
- Dahl, A., 451, 466
Dallenbach, K.M., 451, 467
Dana, C.L., 176, 184
Darwin, C., 22, 169, 170
Davis, H., 116, 128
Davis, L.M., 493, 496, 502
Diamond, S., 420, 435

- Dobell, E.M., 439, 466
 Doll, E.A., 351, 379
 Downey, J.E., 61, 66
 Duffus, R.L., 263
 Dunlap, K., 464, 466
 Dusenberry, D., 181, 184
 Dvorak, B.J., 347, 348
- Efron, D., 373, 379
 Ellis, R.S., 310
- Felekey, A.M., 181, 184
 Fields, P.E., 35, 40
 Fillmore, E.A., 393, 399
 Foley, J.P., Jr., 373, 379
 Freeman, F.N., 386f., 398
 Freeman, F.S., 310, 357, 379
 Freeman, G.L., 92, 111
 Freud, S., 265, 293, 499, 502
 Frisbie, R.D., 482, 488
- Galton, F., 382, 398
 Garrett, H.E., 332, 337
 Garrett, J.E., 370, 379
 Garrison, S.C., 323, 337
 Garth, T.R., 370, 379
 Garvey, C.R., 244, 256
 Gates, A.I., 422, 434
 Gellermann, L.W., 35, 40
 Gesell, A., 48, 52-57, 66, 332
 Gilliland, A.R., 229, 235
 Girden, E., 474, 488
 Goddard, H.H., 382, 398
 Goodenough, F.L., 183, 184, 188, 202, 208,
 329, 330, 337
 Gordon, H., 393, 398
 Graves, E.A., 451, 466
 Graves, K., 395, 398
 Grether, W., 35, 40
 Groves, E.R., 278, 283, 294, 295
 Gurnee, H., 151, 153
 Guthrie, E.R., 168
- Hagman, E.P., 417, 434
 Haines, W.W., 262, 294
 Hall, O.M., 289, 294
 Harlow, H.F., 33, 34, 40, 78, 85, 189-192,
 203, 208, 352, 379, 473, 488
 Hart, B., 272, 294
 Harter, N., 406, 434
 Hartshorne, H., 214, 216, 235
 Haupt, I.A., 109, 111
 Hayes, S.P., 110, 111
 Head, H., 84, 85
 Hempstead, L., 102, 111
- Henmon, V.A.C., 337, 374, 379
 Herrick, C.J., 85
 Herrick, V.E., 215, 216, 235
 Hildreth, G., 362-363, 379, 384, 385, 398
 Hilgard, E.R., 497, 502
 Hilgard, J.R., 46, 57, 66
 Hill, G.E., 215, 235
 Hirsch, N.D.M., 393, 398
 Hollingsworth, L.S., 332, 337, 365, 379
 Holmes, F.B., 185, 188, 198-200, 208, 209
 Holt, F.O., 374, 379
 Holzinger, K.J., 386, 398
 Honzik, C.H., 137, 153
 Hoskins, R.G., 239, 256
 Howard, E.E., 276, 294, 295
 Howell, W.H., 108, 111, 239, 256
 Hull, C.L., 493, 496, 502
 Hunt, W.A., 177, 178, 180, 184, 185
 Hunter, W.S., 34, 40, 430, 434
 Hurlock, E.B., 150, 153
 Husband, R.W., 35, 40, 150, 151, 153, 179,
 185, 233, 235, 244, 256, 421, 425, 428,
 434, 460, 466, 493, 494, 500, 502
 Husband, R.W., Sr., 342, 348
 Huse, B., 495, 502
 Huxley, A., 414-416, 435
- Ishahara, S., 111
 Israel, R.H., 352, 379
 Itard, J.M.C., 31, 40
- James, W., 206, 431, 435
 Jastrow, J., 311
 Jenkins, J.G., 310, 451, 459, 467
 Jensen, K., 46, 66
 Jersild, A.T., 44, 45, 57, 66, 177, 178, 185-
 188, 191, 198-200, 208, 209, 432-435,
 492, 502
 Johnson, W., 61, 67
 Jones, E., 260, 265, 294
 Judd, C.H., 431, 432, 435
- Kanner, L., 181, 185
 Katz, B., 295
 Katz, S.E., 225, 235
 Katzoff, E.T., 251, 257
 Kaunitz, R.M., 332, 337
 Kelley, T.L., 325, 337
 Kellogg, W.N., 23-28, 32, 40, 436, 467
 Kennedy, J.L., 16, 18
 Key, C.B., 393, 399
 Kitson, H.D., 414, 435
 Klineberg, O., 294, 369, 370, 379, 389, 398
 Knower, F.H., 181, 184
 Köhler, W., 28, 30
 Kounin, J.S., 60, 67

- Kretschmer, E., 244, 256
 Krueger, W.C.F., 416, 435

 Laird, D.A., 222, 223, 235
 Landis, C., 177, 178, 180, 182, 185, 225, 235
 Langfeld, H.S., 181, 185
 Larson, J.A., 174, 185
 Lashley, K.S., 82, 85
 Lathan, C., 35, 40
 Leahy, A.M., 387, 389, 398
 Ieeper, R., 448, 468
 Leonard, W.E., 280, 281, 294
 Lepley, W.M., 419, 435
 Leuba, C.J., 153
 Liang, B.T., 454, 467
 Lickley, J.D., 85
 Link, H.C., 205, 206, 209, 295
 Linton, R., 372, 373, 380
 Locke, J., 403
 Louttit, C.M., 355, 380
 Lowrey, L.G., 279, 294
 Ludgate, K.E., 244, 257
 Luh, C.W., 454, 467
 Luria, A.R., 176, 185
 Lyons, E., 197, 209

 Marquis, D.P., 59, 67
 Maslow, A.H., 34, 40, 216, 227, 228, 235, 248, 256
 Maurer, S., 60, 67
 May, M.A., 214, 216, 235
 McBride, K.E., 84, 85
 McCarthy, D., 63, 67
 McDonald, W.T., 445, 467
 McDougall, W., 473, 488
 McGeoch, G.O., 424, 435, 445, 446, 454, 467
 McGeoch, J.A., 438, 444, 445, 446, 467
 McGraw, M., 57, 67
 McKinney, F., 292, 294, 440, 446, 467
 Mead, M., 249, 256, 284, 294
 Meltzer, H., 448, 467
 Menninger, K.A., 225, 226, 235, 266-269, 294
 Menzies, R., 449, 467
 Merrill, M.A., 314, 337, 476, 477, 488
 Metfessel, M., 36, 40
 Miles, C.C., 253, 257, 351, 352, 361-362, 376-377, 380. *See also* Cox, C.M.
 Miles, W.R., 61, 67, 110, 111, 376-377
 Miller, D.C., 113, 128
 Miner, J.B., 345, 348
 Mitchell, B.C., 386f., 398
 Mitchell, F.D., 331, 337
 Moede, W., 149, 153
 Moffat, D., 206, 209

 Morgan, J.J.B., 47, 67, 156f., 168
 Morris, W.W., 442, 467
 Moseley, D., 56, 67
 Moss, F.A., 229, 235, 261, 294
 Murphy, G., 147, 153, 228, 235, 457, 466
 Murphy, M., 54, 67
 Musetti, C.L., 453, 467
 Myerson, A., 163-168

 Nafe, J.P., 124, 128
 Nemzek, C.D., 323, 337
 Newcomb, T.M., 147, 153, 228, 235
 Newman, H.H., 391f., 399
 Nissen, H.W., 30, 40, 136, 153

 Oliver, R.A.C., 372, 380
 Omwake, L., 193, 209
 Outhit, M.C., 383, 384, 399

 Padilla, S., 56, 67
 Paterson, D.G., 243, 244, 257, 332, 334, 337, 339, 348
 Patry, F.L., 276, 294
 Patterson, C.H., 485, 488
 Pavlov, I.P., 412, 435
 Perl, R.E., 193, 209
 Piaget, J., 476, 488
 Pintner, R., 332, 334, 337, 380, 396, 399
 Pressey, S.L., 350, 380, 409, 429f., 435, 437, 438, 468
 Pyle, W.H., 424, 435

 Remmers, H.H., 439, 468
 Rhine, J.B., 16, 18
 Richmond, W.V., 257, 295
 Robinson, E.S., 420, 435
 Rossman, J., 480, 481, 488
 Ruch, F.L., 425, 435
 Ruch, G.M., 426, 427, 435
 Ruch, T.C., 424, 435
 Ruckmick, C.A., 181, 185

 Schiller, A., 60, 67
 Schneck, M.R., 332, 337
 Schott, E.L., 395, 399
 Seabury, D., 294
 Sears, R.R., 147, 148, 153, 272, 294
 Seashore, C.E., 128
 Seashore, R.H., 295
 Settlage, P.H., 33, 34, 40
 Shaffer, L.F., 295
 Sheldon, W.H., 233, 235
 Shepard, J.F., 54, 55, 67
 Sherman, M., 46, 67, 393, 399
 Sherrington, C.S., 177, 185
 Shirley, M., 49, 54, 67

- Skeels, H.M., 388, 393, 399
 Skodak, M., 388, 399
 Smith, G., 279, 294
 Smith, M.E., 62, 67
 Sorenson, H., 377, 380
 Spearman, C., 324, 325, 337
 Spence, K.W., 35, 40
 Spranger, E., 232, 235
 Squires, P.C., 32, 41
 Stagner, R., 211, 220, 235, 251, 257, 289, 294, 473, 488
 Stevens, S.S., 116, 128
 Stone, C.L., 481, 482, 488
 Stratton, G.M., 426, 435
 Strayer, L.C., 57, 67
 Stromberg, E.L., 253, 256
 Strong, E.K., 230-231, 236, 270
 Sullivan, E.B., 147, 153
 Swift, E.J., 439, 468, 473, 488
 Symonds, P.M., 295
- Taylor, V.B., 85, 128
 Terman, L.M., 314, 323, 324, 337, 340, 359-365, 380, 476, 477, 488
 Terman, S.W., 109, 111
 Thisted, M.N., 439, 468
 Thompson, H., 56, 66
 Thorndike, E.L., 133, 153, 325, 337, 415, 435
 Thorndike, R.L., 229, 236
 Thurstone, L.L., 325, 337
 Tinker, M.A., 97, 98, 111
 Tinklepaugh, O.L., 34, 41
 Titchener, E.B., 440, 468
 Tolman, E.C., 137, 153
 Traphagen, V., 295
 Travis, L.E., 61, 67
 Triplett, N., 145, 153
 Troland, L.T., 128
- Trowbridge, M.H., 415, 435
 Tsai, L.S., 60, 67
 Tunis, J.R., 347, 348
- Valentine, W.L., 11, 18
 Van Gelder, D., 180, 184
 Van Ormer, E.B., 451, 468
 Van Waters, M., 280, 294
 Vaughn, J., 146, 153
 Villiger, E., 85
 Von Helmholtz, H.L.F., 93, 300
- Warden, C.J., 136, 153, 420, 435
 Warren, H.C., 440, 468
 Waters, R.H., 448, 468
 Watson, J.B., 46, 61, 67, 186, 199, 204, 209, 245, 257, 472, 488
 Webb, E.T., 156f., 168
 Wechsler, D., 301, 310
 Weisenberg, T., 84, 85
 Wellman, B.L., 388, 390, 399
 Wembridge, E.R., 351-355, 380
 White, W.A., 274, 275, 294
 Williams, W., 154, 155, 168
 Willoughby, R.R., 229, 230, 236
 Wolfe, J.B., 33, 41, 47, 67
 Wolfe, D.L., 16, 18, 28-29, 41
 Wolfe, H.M., 420, 435
 Wood, T.W., 147, 153
 Woods, F.A., 382, 399
 Woodworth, R.S., 116, 128, 460, 468
 Worcester, D.A., 440, 468
 Wright, V.C., 276, 277, 295
 Wundt, W., 311
 Wylie, I.A.R., 247, 257
- Young, K., 211, 236, 250, 257, 295
 Young, P.T., 117, 118, 128

INDEX OF SUBJECTS

- Achievement tests, 332-335
Adrenal glands, 243
Adrenalin, 173, 174
Aesthetic abilities, inheritance of, 44
 and intelligence, 328-330
Age, and intelligence, 376-378
 and mental hygiene, 290-291
Amnesia. *See* Forgetting, Memory, Repression
Anger, 169, 177, 179, 183, 189
 control of, 201-202
 prevention of, 203-204
Animal abilities, Chapter II
 maturation of, 54-56
Aphasia, 84-85
Army Alpha, 312, 367, 394
Army Beta, 332-333
Ascendance, 227-228
Attention, characteristics, 90
 in child, 63
 -getting, 143-144
Attitudes, formation, 252-253
Audition, Chapter VI, 112 f.
 in newborn, 46
Autonomic, 171-172
Aveyron, wild boy of, 30-32
- Behavior variables, 9
Birds, flight of, 56
 song of, 36-37
Birth equipment, 42-47
Blindness, 87
Brain, Chapter IV
 in emotions, 170-172
- Case study method, 14
Cerebrum, Chapter IV, 170-171
Child, abilities, in infancy, 23 f.
 adopted, 386 f.
 development, Chapter III
 gifted, 359 f.
 languages, 62-63
 maturation, 56-58
 problem solving, 28
 social behavior, 29
 thought, 62-63
 wild, 30-32
Chimpanzee, abilities, 23 f.
 social behavior, 29-30
Chords, 114
Clothing, visual principles in, 101-103
College grades and earnings, 346
Color, deficiency, 109-111
 preferences, 109
 vision, 106 f.
 in monkeys, 35
 zones in retina, 108-109
Common sense, 13
Compensation, 267-268
Competition, 145-146
Concussion amnesia, 450-451
Conflict, 258, 261
Contiguity, 420-421
Correlation, 305-309
Criminality, 284, 285
- Delinquency, 284-285
Delayed reaction, 34
Delusions, 273-274
Development. *See* Maturation

- Distance, judgment of, 104-106
- Distribution of practice, in learning, 424
in memory, 439
- Dreams, 498 f.
- Effect, law of, 416-418
- Ego, 143-145
- Emotion, Chapters IX, X
acquisition of, Chapter X
adult, 204-207
control of, 197 f.
facial expressions in, 180-183
forestalling, 202-204
innate, 186-189
native stimuli, 92
neural control of, 170, 172
in newborn, 47
persistence of, 192
physiological factors in, 172-183
in reasoning, 486
- Environment, and intelligence, Chapter XVIII
limitations of, 392 f.
pressures influencing personality, 249-255
and racial intelligence, 386 f.
- Evolution, 22-23, 38-39
- Experimental method, 15-18
- Extra-sensory perception, 16
- Extraversion, 221-224
- Eye, 93 f.
- Facial expression, in emotions, 180-183
and personality, 233-234
- Fallacies, about animal abilities, 37-38
in reasoning, 485 f.
- Family, and personality, 250-251
resemblances, 43
- Fantasies, 273
- Fatigue, 134
- Fear, 169, 179, 190-193
innate, 186-189
maturation in, 190
prevention of, 203-204
removal of, 198-201
- Feeble-mindedness, 351-356
- Forgetting, Chapter XX
active and passive, 454 f.
causes of, 444 f.
concussion, 450 f.
deliberate, 463 f.
interference in, 444 f.
of pleasant and unpleasant, 447 f.
retroactive inhibition and, 444 f.
during sleep and waking, 451 f.
total, 440 f.
- type of material and rate of, 438 f.
- See* Memory
- Frequency, law of, 414-416
- Freudian slips and errors, 265
- Generalization, animals, 35
in thinking, 476-477
- Genetic, method, 14
viewpoint, 21-22
- Glands, 239-243
adrenals, 243
parathyroid, 241
pituitary, 241-242
sex or gonads, 242-243
thyroid, 239-241
- Guidance, educational and vocational,
Chapter XVI
- Handedness, 59-62
- Humor, 193 f.
- Hunger, 133-134
- Hypnosis, 493 f.
- Idiots savants, 330-331
- Illusions, 100-103
- Image, after, 107-108
- Imagination, 477 f.
child, 63
- Incentives, to learn, 413-414
See also Motivation.
- Incidental memory, 458 f.
- Individual differences, Chapter XIV
laws of, 309-310
in learning, 425-429
nature of, 299-300
range of, 301-302
samples of, 300-301
- Inferiority complex, 266-269
- Inheritance, 42-44
of handedness, 60
of intelligence, Chapter XVIII
- Insanity, 42-43
- Instinct, 139-141
- Intelligence, Chapters XIV-XVIII
adult, 316-319
age and, 376-378
child, 26
chimpanzee, 26
and college success, 341-343
constancy of, 322-324
educability of various levels of, 339
of famous people, 357 f.
feeble-mindedness, 351-356
generality of, 324-327
group differences in, Chapter XVII

- Intelligence—*Cont'd*
 growth of, 316, 350
 heredity and environment in, Chapter XVIII
 IQ, 315-317
 maturation of, 51-52
 measurement of, Chapter XV
 nature of, 319-327
 nonintellectual abilities, 327-336
 and personality, 217
 and physique, 360, 365
 race and, 366 f.
 social, 228-229
 and speed of learning, 425-426
 superiority, 356-365
 tests, construction of, 312-313, 371
 tests for children, 313-315
 of twins, 390-392
- Interests, changes in, 162
 of gifted, 361, 364
 vocational, 230-231
- Introspection, 13, 120
 in emotions, 170
- Introversion, 221-224
- Invention, 480 f.
- Jealousy, 204
- Language, animals, 26
 development, 62-64
 disorders, 83-85
 and thought, 472 f.
 in twins, 57
 of wild boy, 31
- Learning, Chapter XIX
 active vs. passive, 422-423
 age and, 425
 association in, 411, 420-421
 in children, 58-64
 comparison of laws, 432-435
 conditioning, 412
 contiguity, 420-421
 curves, 404-411
 effect and vividness, 416-418
 individual differences in rates of, 425-429
 intelligence and, 425-426
 intercorrelations, 428-429
 and maturation, 47, 54
 meaning in, 421-422
 and memory, 456 f., 460 f.
 plateau in, 406-408
 practice, or frequency, in, 414-416, 426
 primacy and recency, 418-420
 recitation, 422-423
 sex and, 425
 transfer of, 429-432
 whole vs. part, 423-424
- Left-handedness, 59-62
 "Lie detector," 174-176
 Lloyd Morgan's Canon, 37-38
 Localization, auditory, 114-119
 cerebral, 81-83
 Locomotion. *See* Walking
 Logic-tight compartments, 264
- Maternal behavior, 135-136
 Maturation, 47-58
 of emotions, 189-190
 Meaning, 421, 422
 Mechanical skills, 327-328
 Memory, Chapter XX
 accuracy of, 441 f.
 characteristics, 437
 curves of, 437 f.
 improvement of, 455 f.
 incidental, 458
 mnemonic devices, 457 f.
 for pleasant and unpleasant, 447 f.
 rate of, 437 f.
 revival through hypnosis, 495
 and speed of learning, 460 f.
 subconscious, 491
 terms, 437
 and testimony, 441 f.
- Mental evolution, Chapter II, 21 f.
 Mental hygiene, 274-293
 adolescent conflicts, 282-285
 causes, physical, 276-277
 in childhood, 278-282
 at college age, 285-289
 definition, 274-275
 in maturity, 289-291
 treatment, 291-293
- Mental set, 491 f.
- Monkey, abilities, Chapter II
 handedness in, 60
- Moods, 207
- Motivation, Chapters VII, VIII
 failures of, 159
 financial, 133, 154
 in learning, 413-414
 and memory, 463
- Motor coordination
 in child, 59
 in child and chimpanzee, 25
 maturation of, 51
 neural, 79
- Nervous system, Chapter IV
 Neurotic tendencies, 225-227
 Normal distribution, 302, 305

- Observational method, 14
 Overlearning, 416, 439
- Pain, 125
 in newborn, 46
- Percentiles, 303-304
- Perception and sensation, 89
- Performance tests, 332-334
- Personality, Chapters XI, XIII
 and ability, 217-218
 body build and, 243-245
 and brain destruction, 80
 changes in, 255-256
 definition, 210-211
 development of, 64, Chapter XII
 deviations in, Chapter XIII
 dual, 264
 and facial appearance, 233-234
 family influences on, 250-251
 generality of traits, 213-217
 innate traits, 237, 239
 and intelligence, 327
 malleability, 248
 methods of estimating, 218-220
 nature of, 211-213
 in newborn, 47
 tests, 220-231
 training, 245, 246
 types, 232, 233
- Pitch, 112-113
- Play, 59
- Postural mechanisms, 126-128
- Praise, 147-148
- Prejudices, 263-264
- Primacy, 418-420
- Projection, 271-272
- Psychology, definition, 4
 fallacies, 11
 methods, 12-18
 origins, 6
 place in science, 7
 purposes, 3, 4, 8
- Punishment, 146-149, 154
 in learning, 417
- Race, intelligence and, 367 f.
 personality and, 249, 253-254
- Random movements, 45-46
- Rationalization, 269-270
- Reading, efficiency in, 98-99
 eye movements in, 97-100
- Reasoning. *See* Thinking
- Recall and recognition, 436
- Recitation, 422-423
- Redintegration, 437
- Reflexes, innate, 46
- Regression, 260-261
- Reminiscence, 452 f.
- Repression, 261-263
- Rewards, 146-149, 161
 financial, 154
 secondary, 33
- Retention. *See* Memory
- Retroactive inhibition, 444 f.
- Sensory, aphasia, 84
 capacities, of child, 46-47
 deficiencies, 44, 86-87, 90, 119, 277-278, 396
 tests, child and ape, 25
 See Vision, Audition, etc.
- Sex differences, in intelligence, 374
 in learning, 425
 in personality, 253
- Sex motivation, 134-135
- Smell or olfaction, 120-121
 in newborn, 46
- Social.
 behavior, of chimpanzee, 25
 cooperation, in animals and children, 28-30
 development, 64
 intelligence, 228-229
 pressures, 141-143
 thought, 150-151
- "Sour-grapes" attitudes, 270-271
- Special abilities, 327-336, 375-376
- Speech. *See* Language
- Stammering, and handedness, 61
- Stimulus, 92
- Subconscious, 489 f.
- Sublimation, 272-273
- Submission, 227-228
- Suggestion, 496 f.
- Symbolic abilities, 32-35, 36
- Taste, 121-123
 in newborn, 46
- Temperature, 123-124
 in newborn, 46
- Testimony. *See* Memory.
- Tests. *See* Intelligence, Personality
- Thalamus, 171
- Thinking, Chapter XXI
 categorization of, 481 f.
 development of, 474 f.
 errors in, 485 f.
 imagination and, 477 f.
 invention, 480 f.
 language and, 472 f.
 nature of, 469-472
 in primates, 32-35

- Thinking—*Cont'd*
 problem solution, 478
 scientific reasoning, 482 f.
- Thirst, 134
- Touch, 124-125
 in newborn, 46
- Transfer of training, 429-432
- Type theories, 304-305
- Twins, intelligence of, 390-392
 maturation in, 56
- Unconscious, Chapter XXII
- Vision, Chapter V, 93 ff.
 color, 35
 distance judgment, 104-106
 eye movements, 97-100
 illusions, 100-103
 in newborn, 46
- Vocational, choice and intelligence, 343-347
 guidance, Chapter XVI
 interests, 230
 possibilities of feeble-minded, 356
 types (introvert-extravert), 224
 uncertainties and mental hygiene, 289
- Walking, in chimpanzee, 24-25
 development of, 49
 and maturation, 48
- Wish-fulfillment, 273

150

H 95G.

15 MAR 1953

DATE OF ISSUE

This book must be returned
within 3, 7, 14 days of its issue. A
fine of ONE ANNA per day
be charged if the book is o
