

Birla Central Library

PILANI (Jaipur State)

Class No :- 796.09

Book No :- W39A

Accession No :- 5088

Acc. No

ISSUE LABEL 5088

Not later the latest date stamped below.

~~30~~

~~200~~

~~1-1-19~~

~~25~~

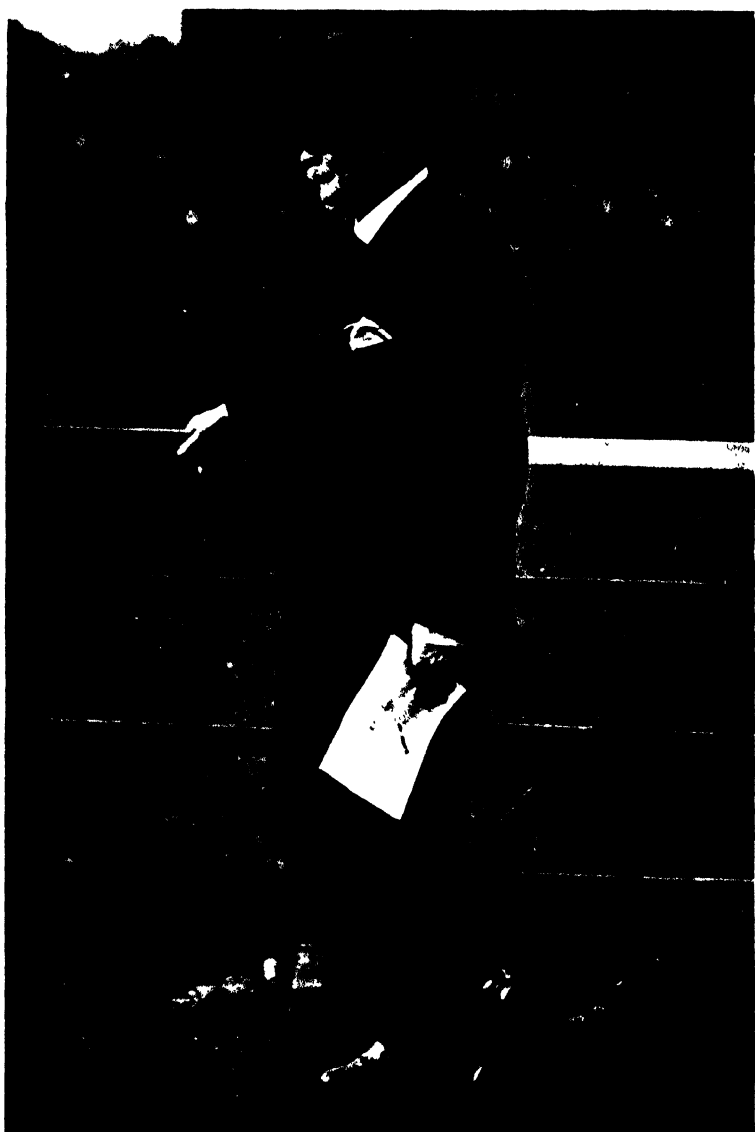

FRONTISPIECE,

Sport and General

JUDGMENT.

The Hon. Sir Montague Shearman, watching the Achilles Club Relay Races at Queen's Club.

ATHLETICS OF TO-DAY

*HISTORY, DEVELOPMENT
AND TRAINING*

BY

F. A. M. WEBSTER

WITH FOREWORD BY
LORD BURGHLEY

Over 300 Illustrations

796.09



FREDERICK WARNE & Co., Ltd.
LONDON AND NEW YORK

✓
796.09

W39 A

5088 C181

C187

To
The Right Hon. LORD AMPHILL,
G.C.S.I., G.C.I.E.
President, Bedfordshire County Amateur Athletic Association

THE WRITER'S GRATITUDE
OF WHICH THESE PAGES
ARE ONE PART

F.A.M.W.

PREFACE

THIS book is the epitome of a quarter of a century of active participation in athletics, combined with personal experience of five Olympiads and the close study of athletic technique and conditions in a good many parts of the globe, from cross-country running and the King's African Rifles Championships in tropical Africa to indoor winter training in the Arctic freeze-up of a Scandinavian winter. I hope it will prove that a rolling stone does sometimes gather a little of the moss of knowledge. My wanderings have certainly provided me with a wealth of memories of splendid sportsmen of many nations and never-to-be-forgotten recollections of the records I have seen broken.

I believe entirely in the supreme value of athletics to the individual and the nation, and I believe that times are changing. I have watched the athletic growth of such countries as Finland and Japan and the revival of Germany after the War through the medium of sport in general and athletics in particular, and, since athletics afford a common meeting-ground in a universal pastime of all peoples, I believe that they may prove a medium for the wiping out of so many of those misunderstandings which made the Great War possible.

In England we are upon the threshold of an athletic expansion such as the pre-War generation never dreamed of. In the past many schools have looked askance at athletics as being too individualistic, but now is the day of individual endeavour, and the team games, admirable though they be in every aspect, do not entirely achieve the purpose which sport should serve in our schools. The boys themselves, sub-consciously perhaps, appreciate this more fully than their elders. This can be proved by statistics. In 1900 the entries for the Public

Preface

Schools Championships numbered just over 100. This year there were over 800 entries from upwards of 100 schools. But even more illuminating is the average of performance of the first ten boys out of the whole of the public schools in Great Britain in 1925 as compared with their successors of 1929. It is given hereunder :

	1925.	1929.
100 Yards	10·58 secs.	10·38 secs.
440 „	54·60 „	53·34 „
880 „	2 mins. 6·82 „	2 mins. 4·70 „
1 Mile	4 „ 45·54 „	4 „ 40·70 „
120 Yards Hurdles	17·38 „	16·36 „
Long Jump	20 ft. 6·82 ins.	20 ft. 8·42 ins.
High Jump	5 „ 5·50 „	5 „ 7·97 „
Shot Put	31 „ 5·50 „	36 „ 0·95 „
Pole Vault	7 „ 8·47 „	9 „ 0·20 „
Javelin	88 „ 9·70 „	124 „ 11·42 „
Discus	88 „ 1·05 „	106 „ 10·12 „

This improvement, which dates mainly from the appointment of athletic blues as Games Masters at the schools, indicates that the number of boys taking an active interest in the sport has increased enormously, and that there has been witnessed a remarkable desire to acquire athletic knowledge. The great schools, such as Eton, Harrow, Charterhouse, Bedford, and Lancing, have been excellently coached in athletics, but there are hundreds of other institutions less fortunate.

Apart from the Author's very real desire to place upon record some history of the development of athletics throughout the world, in the hope that the present and future generations may emulate and improve upon the feats of their forefathers, this book is written primarily for the benefit of those young athletes who do not enjoy the benefit of first-class coaching. I do not believe in athletics for the honours they bring to the individual, for all the athletic glory ever gained is not worth a month's ill-health, nor can it justify the breeding

of a conceited puppy. But I do hold that athletics is the fundamental basis of success in every other form of sport and is unparalleled as a means of producing good health and physical cleverness.

Again, I do not believe in the encouragement of one type of event at the expense of others. For this reason I have endeavoured to inculcate a love of those field events which, in the past, have been so sadly neglected in England, but which are just beginning to come into their own, because people realize that their practice develops in man or boy patience, painstaking perseverance, self-control—without which success cannot come—and the excellent physical attributes of balance, quickness, and a just sense of rhythm. These events will give a boy a strong, evenly-developed body, and they will not cause him to overstrain himself.

Upon the question of training for boys, I hold very definite opinions. Boys of under 16 years of age should only "play at athletics." A boy of 12 should not run further than a furlong, and a boy of under 16 should be limited to 440 yards, run as half a mile, and should not be allowed to use a shot weighing more than 8 lb. Between the ages of 10 and 16 a boy should be attaining his physical strength and acquiring athletic technique. Eighteen is quite young enough for him to begin serious training, and then he should be overhauled by a doctor to see if he is fit to undertake the strain of athletic preparation.

Boys, I believe, can stand any amount of athletic practice, up to the extent of their own enjoyment of the work. What brings about the breakdowns is too much and too early competition, from which mental excitement is inseparable and upon which nervous exhaustion ensues. Nevertheless boys should be allowed a few competitions each year, with other boys in their own class, to enable them to get over the bugbear of stage fright while they are young enough not to be seriously affected by it.

A rational course of athletic exercises will go far to turn the weak boy into a strong young man, but if he wishes to profit

Preface

by his improved physique he must master the technique of the events he favours. In this connection I think the reader may learn a lot from the sketches and diagrams and the action photographs which have been collected from the four corners of the earth to illustrate this book.

I am especially grateful to my friends, Miss Kitty Mitchell, who prepared the drawings, and to Mr. H. Hall, of Messrs. Sport & General, L. T. Bond, C. I. Lopdell, C. F. Chapman, K. H. Pridie, H. A. Simmons, and the Amateur Athletic Associations of Finland, France, Germany, Hungary, and Sweden, who have kindly permitted the reproduction of photographs in their possession. Finally, my very real gratitude is due to Lord Burghley, not only for his Foreword, but also for his helpful criticism of the hurdling chapters; Mr. Geo. Hogsflesh for official data relating to the A.A.A.; and to Messrs. M. J. Brooks, C. L. Lockton, J. W. A. Reay, W. Sapte, and the late Walter Rye, for a wealth of information and anecdotes relating to the early history of athletics in England and Germany.

F. A. M. WEBSTER.

CONTENTS

	<i>Page</i>
PREFACE - - - - -	vii
FOREWORD BY LORD BURGHLEY - - - - -	xv
<i>Chapter</i> PART I.	
I. THE GROWTH OF MODERN ATHLETICS - - -	I
PART II.—THE TRACK EVENTS.	
II. THE SPRINTS—100 TO 300 YARDS - - -	38
III. THE EVENT SUI GENERIS—440 YARDS - - -	56
IV. THE SHORT MIDDLE DISTANCES—600 to 1,000 YARDS - - - - -	68
V. CLASSICAL DISTANCES—1,500 METRES AND 1 MILE - - - - -	78
VI. THE DISTANCES—2 to 10 MILES - - - - -	91
VII. RELAY RACING - - - - -	106
VIII. THE MARATHON RACE - - - - -	115
IX. THE LONG DISTANCES—30 to 100 MILES - - -	126
X. THE HIGH HURDLES—120 YARDS and 110 METRES	132
XI. THE LOW HURDLES—220 YARDS, 400 METRES, 440 YARDS - - - - -	151
XII. THE STEEPLECHASE: 1,320 YARDS, 3,000 METRES, AND 2 MILES - - - - -	161
XIII. CROSS-COUNTRY RUNNING - - - - -	167
XIV. THE WALKS - - - - -	176
PART III.—THE FIELD EVENTS.	
XV. THE HIGH JUMP - - - - -	184
XVI. THE LONG JUMP - - - - -	204
XVII. THE HOP, STEP, AND JUMP - - - - -	219
XVIII. THE POLE VAULT - - - - -	227
XIX. THROWING THE JAVELIN - - - - -	253
XX. THROWING THE DISCUS - - - - -	278
XXI. THROWING THE HAMMER - - - - -	298
XXII. PUTTING THE SHOT - - - - -	321
XXIII. SOME POINTS IN ATHLETIC SCIENCE - - -	343
APPENDIX: TABLES OF RECORDS - - - - -	356
INDEX - - - - -	363

LIST OF PLATES

<i>Plate</i>	<i>Page</i>
JUDGMENT: The Hon. Sir Montague Shearman - - -	<i>Frontispiece</i>
1. OLD-TIME CHAMPIONS: 1, C. L. Lockton. 2, The Hon. M. J. Brooks 3, E. H. Pelling. 4, The late Walter Rye - - -	16
2. OLD-TIME MILERS: R. E. Webster v. Earl of Jersey, 1865 WHICH IS HIS PROPER EVENT? 2 and 3, J. E. London - - -	17
3. HISTORIC TEAMS: British Empire v. U.S.A., 1928. Waseda University v. Achilles Club, 1928 - - -	32
4. HISTORIC SKIPPERS: AMBASSADORS OF EMPIRE SPORT: A GREAT SPORTING TRIO - - -	33
5. THE SPRINTS: Starting Positions - - -	48
6. THE SPRINTS: 1, W. R. Applegarth. 2, H. F. V. Edward. 3, H. M. Abrahams 4, Finishing Faults - - -	49
7. THE SPRINTS AND QUARTER MILE: 1, H. Kornig. 2, J. W. J. Rinkel. 3, Eric Liddell. 4, C. Paddock - - -	64
8. THE QUARTER MILE: 1, The Start—Achilles v. Waseda University. 2, D. Barrington-Hudson. 3, O. Anderson. 4, G. M. Butler. 5, A. G. Hill - - -	65
9. THE HALF MILE: 1, D. G. A. Lowe winning from E. Martin. 2, O. Peltzer. 3, L. Hahn - - -	80
10. THE HALF MILE: 1, D. G. A. Lowe beating S. Martin. 2, H. S. Townend. 3, Lowe showing correct action - - -	81
11. THE MILE: 1, P. Nurmi. 2, Nurmi beating Hahn. 3, A. G. Hill beating H. B. Stallard 4, C. Ellis. 5, J. Binks - - -	96
12. THE DISTANCES: 1 and 2, H. Kolchmainen. 3, B. C. V. Oddie. 4, J. E. Fowler-Dixon. 5, A. F. H. Newton. 6, W. G. George. 7, A. Shrubbs - - -	97
13. BRITISH EMPIRE v. U.S.A., 1928: ACHILLES v. WASEDA UNIVERSITY, 1928 - - -	112
14. BRITISH EMPIRE v. U.S.A., 1928 - - -	113
15. GREAT MARATHON MEN: 1, H. Payne. 2, S. Ferris 3, P. Dorando. 4, W. Kolchmainen. 5, P. Dorando as he is to-day. 6, A. Stenroos	128
16. THE HIGH HURDLES: From Take-off to Landing - - -	129
17. HURDLING EXERCISES - - -	144
18. HURDLING EXERCISES - - -	145
19. THE HURDLES: 1 and 2, Earl Thomson. 3, Good style and bad. 3, The old bent leg style - - -	148

List of Plates

xiii

<i>Plate</i>	<i>Page</i>
20. THE HIGH HURDLES: 1, F. R. Webster. 2, G. C. Weightman-Smith. 3, F. R. Gaby - - - - -	149
21. THE LOW HURDLES: 1, J. Gibson, T. C. Livingstone-Learmonth, and Lord Burghley. 2, Lord Burghley beating S. Kieselhorst. 3, Lord Burghley and Livingstone-Learmonth. 4, Lord Burghley	156
22. THE STEEPLECHASE: 1, V. E. Morgan. 2, J. E. Webster. 3, Lord Burghley. 4, T. C. Livingstone-Learmonth and J. Montgomery	157
23. CROSS-COUNTRY RUNNING: 1, W. Ritola. 2, P. Nurmi. WALKING: 3, G. V. Bonhag. 4, C. E. Lerner - - - - -	176
24. THE HIGH JUMP: Western Roll Style. H. M. Osborn - - - - -	177
25. THE HIGH JUMP: Eastern Cut-Off Style. H. A. Simmons - - - - -	192
26. THE HIGH JUMP: Eastern Cut-Off Style. H. A. Simmons, R. Landon and P. Lewden - - - - -	193
27. THE HIGH JUMP: 1 and 5, B. Howard Baker. 2, H. A. Simmons. 3, A Suppling Exercise. 4, Hip flexibility exercise - - - - -	208
28. THE LONG JUMP: 1, Correct Take-Off Action. 2, R. W. Revans—the Hang. 3, R. W. Revans—the Kick. 4, V. B. V. Powell - - - - -	209
29. THE LONG JUMP: 1, P. O'Connor. 2 and 4, E. Ham. 3, Alzieu - - - - -	224
30. THE HOP, STEP, AND JUMP: 1, Folk Jansson. 2, P. O'Connor. 3, C. Nambu - - - - -	225
31. THE HOP, STEP, AND JUMP: 1, M. Oda. 2, H. de Boer-Holland. 3, T. Ahearne - - - - -	226
32. THE POLE VAULT: 1, F. Gonder. 2, B. Soderstrom. 3, E. Archibald. 4, Frank Foss - - - - -	227
33. THE POLE VAULT: 1, 2, and 3, C. Hoff. 4, Lee Barnes - - - - -	238
34. THE POLE VAULT: F. R. Webster—1, The Shift. 2, The Hang. 3, The Vertical Lift. 4, The Kick Release - - - - -	239
35. THE POLE VAULT: 1, The Take-Off. 2, The Pendulum Swing. 3, The Arm Pull. 4, The Leg Shoot. 5, The Turn. 6, The Vertical Lift - - - - -	240
36. THE POLE VAULT: 1, C. Harlemann. 2, E. Rydberg. 3 and 4, Sabin Carr - - - - -	241
37. THE POLE VAULT: 1, F. H. Sturdy. 2, "Peggy." 3, "Joan." 4, The Right Age to Start. 5, Correct Starting Position - - - - -	256
38. GREAT SPEARMEN: 1, Eric Lemning. 2, F. O. Kitching. 3, Jonni Myrta - - - - -	257
39. THROWING THE JAVELIN: 1, Demonstrating Final Arm Extension. 2, Bela Szepes. 3, B. Schlokat. 4, E. Lemming - - - - -	260
40. THROWING THE JAVELIN: 5, J. Myrta. 6, F. A. M. Webster. 7, J. Saaristo. 8, The Author and S. Lay - - - - -	261
41. THROWING THE JAVELIN: S. Lay—1, Correct Vertical Position of Arm. 2, Correct Delivery Finish. 3, Follow Through Action - - - - -	268

<i>Plate</i>	<i>Page</i>
42. THROWING THE JAVELIN: "Breaking-Up"—4, Completion of Follow Through. 5, "The Carry Through." 6, "The Reverse"	269
43. THROWING THE JAVELIN: Teaching Technique	- 272
44. THROWING THE JAVELIN: 1, Eino Penttilä. 2, Bela Szepes. 3, Lord Burghley. 4, K. Sumiyoshi	- 273
45. THROWING THE DISCUS, GREEK STYLE: 1, "Discobolus." 2, D. Gillis. 3 and 4, M. Sheridan	- 288
46. DISCUS CHAMPIONS: 1, M. C. Nokes, K. H. Pridie, and F. A. M. Webster. 2, K. Marvalits. 3, W. E. B. Henderson	- 289
47. THROWING THE DISCUS, FREE STYLE: 1, G. M. Moll. 2 and 4, A. E. Flaxman. 3, C. Houser	- 290
48. THROWING THE DISCUS, FREE STYLE: 5, H. Hoffmeister. 6, A. E. Flaxman. 7, F. A. M. Webster. 8, G. M. Moll	- 291
49. THROWING THE DISCUS, FREE STYLE: 9, K. Marvalits. 10, K. Askildt. 11, O. Zallhagen. 12, F. A. M. Webster	- 294
50. THROWING THE DISCUS: 1, G. M. Moll. 2, W. E. B. Henderson. 3, T. Lieb. 4, C. P. Hoffman	- 295
51. THROWING THE DISCUS: Nude Studies	- 298
52. THROWING THE DISCUS: 1, American Style of "Jump" Turn. 2, Landing from "Jump" Turn. 3, C. Silfverstrand demonstrating. 4, Faults Often Seen	- 299
53. THE HAMMER-THROWER'S PHYSIQUE: The late A. E. Flaxman	- 302
54. THROWING THE HAMMER: The Swing—1, A. E. Flaxman. 2, M. C. Nokes. 3, T. Nicholson. 4, J. Flanagan	- 303
55. THROWING THE HAMMER: The Swing (continued)—5 and 6, A. E. Flaxman. The Turn—7, Matt McGrath. 8, T. Nicholson	- 304
56. THROWING THE HAMMER: The Turn (continued)—9, 10, 11 and 12, A. E. Flaxman	- 305
57. THROWING THE HAMMER: The Turn (continued)—13 and 16, A. E. Flaxman. 14 and 15, M. C. Nokes	- 320
58. PUTTING THE SHOT: 1, The Author and Dr. R. S. Woods. 2, D. Horgan. 3, W. E. B. Henderson. 4, H. Brix	- 321
59. PUTTING THE SHOT: 1, G. Hartranft. 2, R. Rose. 3, E. Hirschfeld. 4, R. L. Howland	- 324
60. PUTTING THE SHOT: 1, K. H. Pridie. 2, J. Kuck. 3, W. W. Coe. 4, Dr. R. S. Woods	- 325
61. PUTTING THE SHOT: 1, J. Daranyi. 2, C. Houser. 3, V. Pörhölä. 4, K. Jarvinen. 5, Dr. R. S. Woods	- 332
62. WHERE AMERICA SCORES: Franklin Field, Philadelphia	- 333

FOREWORD

By LORD BURGHLEY

Every one interested in athletics will greatly appreciate this work of Captain Webster's. For years his name has been connected with athletics, and he is one of the most enthusiastic followers of this sport that I know. He is eminently qualified to write on this subject, as he has personally seen in action all the "super"-athletes who have run on this side of the Atlantic, and he has done much towards popularizing those comparatively new events, the discus and javelin, in this country.

He is to be congratulated on the difficult task which he has accomplished, for he has succeeded in turning what, to the casual reader, is usually a dull and complicated list of technical details on actually how to do the events into a most readable and easily assimilated form. And, although the experts will always differ in opinion over small points, Captain Webster has steered well to the middle course, and the views he expresses are representative of the bulk of first-class athletic opinion.

But, besides its constructive value, this book fills a long-felt need in the running world, for not only does it contain a history of athletics in general, but also most realistic accounts of the great races of the last thirty years, and champions,

Foreword

who were little more than names before, now become very real figures.

I strongly advise all would-be athletes, and particularly the Field Events men, to read this book; and I can assure all those who are in any degree interested in athletics that they will find the stories of great races and the anecdotes of great runners contained in this book most entertaining.

ATHLETICS OF TO-DAY

PART I

CHAPTER I

THE GROWTH OF MODERN ATHLETICS

AMONG the normal attributes of every human being are the actions of walking, running, jumping and throwing, and, since the possession of any active sense leads its possessor to the inevitable wish to test its quality against the similar faculties of others, it seems safe to assume that, so long as there has been a human race upon earth, just so long have there been athletic contests of one kind or another.

I feel, in fact, that I can offer concrete evidence to this effect. I have lived among the natives of East and Central Africa, who, by our standards of measurement, are as primitive as were our wood-stained forefathers. These African savages have lived, ethnologists tell us, for thousands, perhaps hundreds of thousands, of years, just as we find them to-day, and, one and all, they are remarkably interested in feats of speed or endurance in running, and skill and strength in jumping and spear-throwing, just as, no doubt, were our own savage ancestors; for all war-like peoples have admiration for feats of speed, strength, or endurance of the human body.

There is no reason to believe, therefore, that athletics in Great Britain received their first impulse from the Lugnasad, or Tailtin Games, held in Ireland as long ago as 1829 B.C., according to the ancient Book of Leinster, or that the growth of the sport throughout a wider field was alone the outcome of the ancient Olympic Games of the Greeks, or the Northern Games of the Vikings. The love of these things is in each man's bones, and the pursuit of athletics is, therefore, not indigenous to the soil of any one country. This particular form of sport, in fact, has formed an integral part of English

Athletics of To-day

town and country life from the earliest times to which chronicles go back.

In the reign of Henry II young Londoners had open spaces allotted to them near the city for the practice of athletics. Henry V was himself a fine runner, according to the bards of that age, and doubtless there were as good, but meaner men whose prowess the minstrels deemed it beneath their dignity to notice. The less natural, but perhaps more scientific, pastimes, such as shot-putting, "casting the barre," and hammer-throwing, seem to be of almost equal antiquity with running and jumping, since Edward III, by statute, prohibited weight-putting, lest it should spoil the practice of archery—a statute, which, to the best of my belief, has never since been repealed. Henry VIII, on the other hand, seems to have viewed athletic sport with great favour and was himself adept at running, jumping, weight-putting and hammer-throwing, but, like many of our modern youths, he had a great *penchant* for female society and was fond of dancing.

In the days of Good Queen Bess, however, it appears from the writings of one Randel Holmes, a wandering North Country bard, that whereas the common folk took delight in sprint and distance races, high and long jumping, and weight-putting and hammer-throwing, the "quality," like Gallio, "cared for none of these things."

The Puritans seem to have put a period to athletics in England and perhaps not without cause. Their grievance does not appear to have been so much against the form of recreation, as against the places and occasions of their practice, the occasions being Sundays and the places the churchyards; while the country fairs of the period, at which sports took place, usually terminated in scenes of uproarious intoxication.

With the fall of the Puritan power all forms of sport gained such vigour as has never since diminished in England.

Unfortunately little or no reliance can be placed upon the "records" which have come down to us from the period prior to the foundation of the Oxford and Cambridge Sports in 1864 and the English Championships in 1866. For example,

one chronicler tell us, quite seriously, that "a butcher of Croydon on December 1st, 1653, ran twenty miles, from St. Albans to London, in less than an hour and a half, and the last four miles so gently that he seemed to meditate"—a performance that makes the present record of 11 miles 1,636 yards in one hour, made by the great Paavo Nurmi, of Finland, look pretty sheepish.

Pepys's Diary is a fruitful source of information to the enquirer into early English athletic history, and from his writings one may judge that the "quality" of that age were always willing to harbour a "dark horse" among their servants, and to spring him on any fancied pedestrian, if sufficient money was forthcoming in wagers. That the nobility themselves had a fondness for athletics is instanced in the case of Lord Arran and Lord Castleham, who had heard of the prowess of Henry V and his nobles in running down a stag, and who did, for a wager and in the presence of King Charles II, "run down and kill a stout buck in St. James's Park." The period of which Pepys writes was, I believe, the beginning of the great age of pedestrianism.

There may be nothing in the make-up of the present day "footman" to suggest the running prowess of his predecessors of the seventeenth century; but that is because, first, better roads, and finally the coming of the railway and more recently motor cars, have changed the nature of his service. In the days when Charles II sat upon the throne our English roads were notoriously bad and a running footman, detailed to go ahead and make arrangements for accommodation on a journey, could travel faster than his noble master in a lumbering coach. Not unnaturally, in an age when men would wager on anything and everything, the masters matched their men against each other, and thus the long line of first-rate pedestrians began.

By the beginning of the nineteenth century it seems that athletics had come to be considered a "low-class sport," but, while many pedestrian matches were made, with the stakes as high as £1,000, there were still events for the amateurs.

These amateurs found their opportunities mostly at the fairs and wakes, which were the direct forerunners of our present-day athletic sports meetings. In view of the post-war popularity of women's athletics, it is interesting to note that at these fairs and wakes the "gentle" sex was catered for with such events as running and "tossing the barre." In those days the prizes were invariably a hat for the men, and a smock, or "she-shirt," for the women. The modest author hesitates to suggest what may have been the exact nature of the latter garment. Other sports referred to as being popular at the beginning of the nineteenth century are "throwing the sledge," which refers obviously to an early form of hammer-throwing, and "tossing the pike," which may perhaps be distantly related to the present day javelin-throwing event. One of the great meetings of those days was that held annually at Bodmin, in Cornwall, which is said to date back to Saxon times.

For a period the profitable profession of pedestrianism flourished in the towns, while the amateur events at the fairs and wakes retained their popularity among the country folk. The year 1817 marks definitely an important milestone in athletic history. In that year Major Mason, of Necton, in Norfolk, formed the Necton Guild, which was, beyond all question, the first English athletic club to come into being. In 1819 the local wake gave place to a sports meeting, at which neither stalls, stands, nor booths for entertainments were permitted, and this meeting lasted until 1826, by which time, the chroniclers tell us, wakes were dying out in all the great towns of the North of England.

The first half of the nineteenth century was notable for the number of matches of an *outré* nature which took place; for example, a race between a man on stilts and a foot runner, and mention has been made already of the alleged remarkable performance of the Croydon butcher who ran from St. Albans to London in under an hour and a half. In further proof of how little reliance can be placed on the records made before athletics were properly controlled one may quote the case of an Italian who is said to have run from Hyde Park Corner to

Windsor in an hour and three-quarters. The absurdity of this is proved by comparison with the time of that other Italian, Pietri Dorando, in the Olympic Marathon race of 1908. He covered the course from Windsor to Shepherd's Bush, some miles less than the distance to Hyde Park, in 2 hours 54 mins. 46 $\frac{2}{3}$ secs., and almost died at the end of the race, which he did not win, as he collapsed completely a few yards short of the winning post.

The system of training by which the pedestrians of the eighteenth and nineteenth centuries prepared themselves for their matches was rigorous enough to kill any of our modern day young athletes, and those who are prone to kick against the pricks of the present day system may learn a lesson from Walter Thom's book on Pedestrianism, published in 1813. According to Mr. Thom's advice on training, the athlete's diet should consist of beef, mutton, stale bread, strong beer, and Glauber salts. Fish, butter, cheese, vegetables, and eggs were forbidden. Constant purging with medicines, the administration of an occasional emetic, and the inducement of profuse sweating by walking under a load of clothes and by lying between feather beds are all recommended as being beneficial to the athlete in training. No wonder the poor fellow needed a certain quantity of strong beer! How completely such a system is opposed to our modern principles of training will appear in a subsequent chapter.

Captain Barclay Allardice, who always competed under the name of Barclay, made many sensational wagers and won many equally sensational matches, walking, for instance, 1,000 miles in 1,000 hours at Newmarket, and at the age of twenty-one years walking 90 miles in 21 $\frac{1}{2}$ hours for a wager of £5,000. His performances at more standardised distances will not strike the reader of to-day as remarkable. To the best of my knowledge among his fastest times were 440 yards in 56 secs., and 1 mile in 4 mins. 50 secs. These times do not compare favourably with the present world's records of J. E. Meredith, U.S.A., 440 yards in 47 $\frac{2}{3}$ secs. (1916) and Paavo Nurmi, Finland, 1 mile in 4 mins. 10 $\frac{2}{3}$ secs. (1923).

Athletics of To-day

The great benefit which athletic sport really derived from the activities of Captain Barclay is to be found in his practice of matching himself against amateurs. This led to the holding of many amateur matches, up to about 1825, at Uxbridge, or on the Newmarket Road, or at Lord's Cricket Ground, and I believe there were regular amateur athletic sports meetings held at the Royal Military College, Sandhurst, about that period.

After the first quarter of the last century athletics among amateurs waned a little, but pedestrianism still went on. In 1825 one, James Metcalf, gave another, J. Halton, 20 yards start in a mile and beat him in the record time of 4 mins. 30 secs. This record stood until 1840, in which year W. Matthews, of Birmingham, covered the distance in three seconds faster time.

Mr. Donald Walker's book of *British Manly Exercises*, published in 1834, suggests that the general standard of running at that time approximated to 440 yards in 60 secs., a mile in 5 mins. and 2 miles in 10 mins. Of the jumps he says that a first rate long jumper will clear 20 ft., a really good high jumper 5 ft. 6 ins. and an extraordinary one 6 ft. Unfortunately I have not been able to secure any satisfactory evidence as to the distances achieved by the weight-putters and hammer-throwers of the pre-championship period.

Between the years 1830 and 1850 all things were moving together towards the great wave of enthusiasm for amateur athletics which was soon to sweep over England. In 1838 well-known amateurs were running under such fanciful pseudonyms as "Neversweat," "The Sprinter" and "Sprightly," but a few years later the fashion had changed and men were not ashamed to run under their rightful names. Pedestrianism was now in its palmyest days, and in 1850, when Hayes beat Tetlow over four miles on the Aintree racecourse, it is said that there was present pretty well the whole sporting population of Liverpool, Manchester, and Newcastle. So great a public interest in the doings of the professionals encouraged the spirit of emulation among the amateurs, and we begin to hear of numerous amateur athletic meetings taking place. There were

other contributory factors. One was the institution of the Volunteer movement ; another was the increasing pressure of professional and business life and the over-crowding of people in towns, which led to a craving for freedom from constriction both in space and clothing, accompanied by violent exercise.

Apart from the Necton Guild and the probable Sandhurst Sports already mentioned, I think the credit for instituting proper athletic meetings must be shared between some of our great public schools, the Royal Military Academy, Woolwich, and Exeter College, Oxford.

The famous "Crick Run" at Rugby appears to have been founded in 1837, and in the same year there were hurdle races at most of the tutors' and dames' houses at Eton, a hundred yards over ten flights of hurdles being the usual course. Shrewsbury followed hard on Rugby in instituting a steeplechase, and in 1845 Eton had a similar event and, in addition, sprint races and hurdle races, which were decided on the road, all on different days.

In 1849 the Royal Military Academy, Woolwich, set an entirely new fashion by holding a properly organized sports meeting for the "gentleman-cadets," in the course of which a thoroughly comprehensive programme was decided. In the following year Captain Eardley-Wilmot presented a silver bugle to be held for one year by the winner of the greatest number of events at "The Shop" sports. That bugle, probably the first amateur athletic challenge trophy ever presented, has long since become covered with the names of its holders, and the custom now is to attach to it each year a small silver medal which bears the winner's name. It is of interest to note that the records of the Royal Military Academy relate that the first winner of the bugle "was a Cornishman of very short stature, but square as a tower and of very great strength. On joining he threw in wrestling all the strongest cadets, and before he left he jumped more than his own height."

Mr. J. H. A. Reay, L.A.C., who won the English 120 yards Hurdles Championship, 1877, in 17½ secs., but whose memory goes back further still, has some vivid recollections

Athletics of To-day

of the great races which were run in the fifties. Up to that time, he says, all the great running had been done by professionals, or by amateurs who ran matches at Primrose Hill, and other spots, and, generally, very early in the morning when no one was about. Among the amateurs he mentions were Captain Machell, Sir Charles Legard and the late C. M. Calton, sometime Marshal of the Admiralty Court, who was one of the earliest Brighton walkers. These early morning matches were made by men of good social standing, who had no other opportunity of exploiting their athletic abilities, as no open amateur sports meetings were then held.

Up to 1850 no athletic sports of any kind were held even at Oxford or Cambridge, but, in that year, Exeter College, Oxford, promoted a meeting in somewhat amusing circumstances. And that meeting has survived to this present day. On the evening of the College Grind, R. F. Bowles entertained in his rooms four fellow undergraduates, all thoroughly discontented with the Oxford hacks they had hired to carry them in the afternoon's steeplechase. Their names were James Aitken, George Russell, Marcus Southwell, and Halifax Wyatt. Mr. Wyatt, the most disgruntled, because his horse had put him down on his head in the road, grumbled that he'd rather run two miles across country on his own feet than ride such a brute again. The others hailed the notion with laughing enthusiasm, and so the stakes were agreed, the officials appointed, and the conditions drawn up. The foot steeplechase of two miles over 24 jumps came off on a flat, marshy farm at Binsey, near Seven Bridge Road, and resulted in a win for Wyatt from Aitken and Scott, all three having taken the last fence in line.

On a subsequent afternoon something more like our modern notion of a sports meeting took place at Port Meadow, the programme being 100, 330, 440 yards and 1 mile on the flat and 140 yards over 10 flights of hurdles set up 10 yards apart. There were also less important stake races at 60 and 150 yards and 100 yards for "beaten horses," or what we now call a Consolation Race. E. Knight won the hurdle race from R. F.

The Growth of Modern Athletics 9

Bowles, while Wyatt took the 100 yards and ran also in the Mile. In the latter event, however, he was heavily handicapped by being given some pounds of shot to carry in an old-fashioned shot belt, slung about his middle, and so managed to finish only second to Aitken.

Looking back at the personal records of the winners at that first Exeter College Sports Meeting, one might well be tempted to repeat the quotation, "The giants were on the earth in those days," for both James Aitken and Halifax Wyatt, besides proving their progress at athletics, achieved Blues for rowing and cricket.

In the Exeter College Summer Meeting of 1851, the high jump and the long jump were both added to the programme, and I believe that Lincoln was the next college to hold a Sports Meeting, and in 1856 St. John's and Emmanuel Colleges gave a lead to Cambridge, but at Oxford the new fashion was spreading far more rapidly, and College Sports were instituted at Balliol, Pembroke, Wadham and Worcester (1856), Oriel (1857), Merton (1858), and Christ Church (1859).

Meanwhile Cambridge, although not boasting so many separate college meetings as Oxford, had, in 1857, started the University Sports. In 1860 the Oxford University Sports, open to all undergraduates, were founded, mainly through the perseverance of the Rev. E. Arkwright, of Merton College. The next important step in progress was, of course, the foundation of the Inter-University Sports. But, before recording that happening, we must go back for a moment to see what was taking place at the schools.

Somewhere about the year 1850, I believe, certain private schools in the neighbourhood of London had begun to hold annual foot races and jumping matches, but the earliest authentic reference to a regular school sports meeting that I have been able to trace relates to such a meeting being promoted at Kensington Grammar School in 1852. In the following year Harrow, Cheltenham, and Durham University all started meetings, and I think St. Albans was another, although there is some evidence that that very ancient school

Athletics of To-day

may have founded its annual sports at an even earlier date.

One hesitates, however, to suggest that schools were not holding sports meetings much earlier than the middle of the nineteenth century. A journalist in his report of Merchant Taylors' School Sports, 1869, states, "The early days of athletics can bring forward Merchant Taylors as one of the first schools to cultivate the athletic taste, and, as far back as memory can recall, there is strong evidence of this particular branch of youthful zeal having received a fair support from the authorities." This writer goes on, further, to speak of the importance of athletics at schools having been well understood, and the sport catered for, fully forty years earlier, *i.e.* in the thirties of last century.

The years in which other important schools commenced their annual sports are Rugby, 1856, Winchester, 1857, and Westminster and Charterhouse, 1861. But by 1860 it may be said that athletic sports had become an accepted and popular part of public school and college life. It will be seen, therefore, that both Oxford and Cambridge were in good case for drawing recruits from among the College athletes and the Freshmen who were coming up from the Public Schools when the Inter-University Sports were instituted in 1864.

Before this important event took place, however, the amateurs outside the Universities had been by no means idle. In 1861 a sports meeting was promoted by the West London Rowing Club for its members, and in 1862 the first Open Amateur Meeting was held. A Mr. W. Price, who was a great patron of pedestrianism, offered a cup to be competed for by amateurs only at Hackney Wick on July 26th. In that race it is interesting to note that W. M. Chinnery, who was English 1 and 4 Miles Champion in 1868 and 1869, finished second to a Mr. Spicer of the Honourable Artillery Company.

Another competitor, the late Mr. Walter Rye, L.A.C. (whose portrait is given on Plate 1, No. 4), died in 1929, but at eighty-five years of age was the oldest living English champion, he having acquired the 7 miles walking title in 1868. He ran his first race in 1861, when seventeen and a half years of age, in a

300 yards contest at the Old Beaufort House Ground, Fulham, in connection with a Volunteer Fête, but fell when lying third. Before he was twenty-one he had run 440 yards in 54½ secs., 880 yards in 2 mins. 8½ secs., and 1 mile in 4 mins. 58 secs. He was a keen entomologist, and part of his training consisted of very long collecting walks in company with a butterfly net.

Mr. Rye gives an illuminating account of the training of that period. In the autumn of 1869 he went into lodgings at the King's Head, Roehampton, his training quarters. Thence it was his custom to walk up to Golden Square each day and walk back *viâ* the West London Cricket Ground, where he stopped to train, after which he continued his walk to Roehampton. Daily associates of his in training were the two Chinnerys and Colbeck. Training over, they partook of half a pint of public house port and an arrowroot biscuit each. The training diet consisted of a large cup of tea and a chop or steak for breakfast, for dinner the same food but half a pint of bitter or old ale reinforced with three pennyworth of gin instead of tea, and the same drink and another chop or steak for supper. Exercise included a run before breakfast with the Barnes Beagles.

In 1864 the amateurs, who had competed at the West London Rowing Club and Mr. Price's meetings, got together and formed the Mincing Lane Athletic Club. The first athletic sports meeting they promoted took place on April 9th, 1864, at Brompton, but it excited little or no public interest, although the papers paid a good deal of attention to the next meeting of May 21st, when W. M. Chinnery won the mile race.

During that year the club acquired its first two challenge cups, the one for the 10 miles Walk and the other for a 220 yards Sprint. In regard to these presentations, it is a curious fact that the 10 miles Walk has never figured in the English Championship programme, while the Furlong was not raised to championship status until 1902.

We come now to the year 1864, which must ever be regarded as the most important in the annals of English athletic history. In 1863 there had been abortive attempts to arrange an

Athletics of To-day

athletic meeting between Oxford and Cambridge, and in 1864 the first meeting between the rival universities took place on the Christ Church Cricket Ground at Oxford. The result was a draw, but the figures are interesting :

THE OXFORD AND CAMBRIDGE SPORTS, 1864

100 yards, B. S. Darbyshire, Ox., 10½ secs.

440 yards, B. S. Darbyshire, Ox., 56 secs.

1 mile, C. B. Lawes, Cam., 4 min. 56 secs.

120 yards Hurdles, A. W. T. Daniel, Cam., 17¾ secs.

200 yards Hurdles, E. Wynne-Finch, Cam., 26¾ secs.

Steeplechase (about 2 miles), R. C. Garnet, Cam., 10 mins.

High Jump, F. H. Gooch, Ox., 5 ft. 5 ins.

Long Jump, F. H. Gooch, Ox., 18 ft.

The Steeplechase and 200 yards Hurdles were decided in that year only. The Shot Put was added in 1865 and still survives. Throwing the Cricket Ball was also added in the same year but only decided that once.

The year 1864 is still further notable in that the first regularly constituted athletic club, the Mincing Lane A.C., held its first sports meetings and the Civil Servants also promoted their first meeting which is as popular a fixture in 1929 as it was in 1864.

In the space of the next two years the cult of athletics and the custom of holding athletic sports meetings spread like wildfire throughout the kingdom. By the beginning of 1866 the amateurs had severed all connection with the professional pedestrians, in the spring of that year the Mincing Lane A.C. changed its name to its present style and became known as the London A.C., and at the same period there was formed in London, mainly of old University men, the Amateur Athletic Club, which may well be regarded as the precursor of our more recently instituted Achilles Club.

This A.A.C., according to its constitution, was formed to "supply the want of an established ground upon which

The Growth of Modern Athletics 13

competitions in amateur athletic sport might take place, and to afford as completely as possible to all classes of gentlemen amateurs the means of practising and competing against one another, without being compelled to mix with professional runners." At that time there were two classes, the "gentlemen amateurs" and the "amateurs" who formed themselves into tradesmen's clubs. Professional handicaps were then becoming more scarce, and many a "pro," unfortunately, found it more profitable to compete disguised as an amateur.

From 1866, both the Amateur Athletic Club and the London Athletic Club were destined to direct the course which English athletics, and perhaps it might not be too much even to say the course of athletics throughout the whole world, were to follow. For both clubs bore their full share of responsibility in those early days for moulding the English Open Athletic Championships into their present form, although to the public of the early sixties it may have seemed that the two bodies were working towards different ends. In the spring of the year of its inception the Amateur Athletic Club promoted the first English Championship Meeting and the events, then as now, were open to *bonâ fide* amateurs from all the ends of the earth. That meeting was a conspicuous success and the first of the long line of English Championships still carried on successfully under the government of the Amateur Athletic Association, and interrupted only during the war period, 1915-1918.

The results of that first Championship meeting make interesting reading and are given here for comparison with present day performances :

ENGLISH CHAMPIONSHIPS, 1866.

100 yards, T. M. Colmore, O.U.A.C., 10½ secs.

440 yards, J. H. Ridley, Eton College, 55 secs.

880 yards, P. M. Thornton, C.U.A.C., 2 mins. 5 secs.

1 mile, C. B. Lawes, C.U.A.C., 4 mins. 39 secs.

4 miles, R. C. Garnett, C.U.A.C., 21 mins. 41 secs.

Athletics of To-day

120 yards Hurdles, T. Milvain, C.U.A.C., 17 $\frac{3}{4}$ secs.

7 miles Walk, J. G. Chambers, C.U.A.C., 59 mins. 32 secs.

Long Jump, R. Fitzherbert, C.U.A.C., 19 ft. 8 ins.

High Jump, T. G. Little, C.U.A.C. and J. H. T. Roupell, C.U.A.C., 5 ft. 9 ins.

Pole Vault, J. Wheeler, City A.M.A.C., 10 ft.

Shot Put, * C. Fraser, London, 34 ft. 10 ins.

Hammer Throw, R. J. James, C.U.A.C., 78 ft. 5 ins.

It will be observed that of the twelve events nine were won by University athletes, and it may be further remarked that the Championships were decided almost immediately after the Inter-University Sports Meeting, and, therefore, at a period of the year which, it is generally agreed, is not the most suitable for the holding of athletic meetings, and when, moreover, the University men would be far more likely to be in condition than the general run of athletes, whose business occupations kept them confined to offices all day, while the shortness of the evenings would afford them but little opportunity for training.

This state of things caused, no doubt, a good deal of comment and discussion, and it soon became apparent that the A.A.C., who in 1868 opened a splendid athletic ground for amateurs at Lillie Bridge, was designed to fill the same position in the world of athletics as does the M.C.C. in cricket or the Leander Club in rowing. Once this position was understood, the non-University athletes began to rally to the L.A.C., and the A.A.C. ceased soon to promote any meetings other than the Annual English Championships.

That there was discontent among the non-University and working class athletes is clear from the writings and reports of the period, but the English are notoriously slow to take action for the overthrow of established institutions, and so for thirteen years the A.A.C., although an obviously decaying body, unwilling to move with the times, continued to maintain its sway. One fruitful source of grievance lay in the fact that the Amateur Rowing Association's definition of an amateur

* Weight of Shot was 18 lb. 10 ozs. instead of 16 lb.

The Growth of Modern Athletics 15

was accepted at Lillie Bridge, and, although their entries were often accepted, this left the provincial athletes, drawn mainly from the artisan, mechanic and labouring classes, properly speaking, ineligible to compete at the English Championships. The London type of athlete, belonging mostly to the professional and business classes, was eligible under the then existing amateur definition, but found themselves bound to compete under a big handicap, owing to the fact that it continued to be the custom to hold the Championship Meeting at Lillie Bridge upon the Monday following the Oxford and Cambridge Sports in March or April.

In the early seventies it is obvious that the character of the English athletic constituency was changing. Up to the end of the sixties the University athletes had formed by far the most important section of the athletic community, both in numbers and by merit of performance, and their entries had supplied fully two-thirds of the competitors at the Championships. But the general dissemination of athletes throughout the land called for the consideration of the two other classes of sportsmen, and it was this task that the A.A.C. either would not or could not face. The point of cleavage came on the proposition that it was unfair to the general run of athletes to hold the Championships in the spring, to which the A.A.C. replied that it would be equally unfair to the University men to hold them at any other time of the year, since it was the policy at Oxford and Cambridge to devote the summer months to cricket, boating, and examinations.

As has been said, the power of the A.A.C. was on the wane, for the only new members it obtained were such men as were anxious to use the Lillie Bridge ground for training purposes. But the power of the L.A.C. waxed as that of the A.A.C. waned. Up to 1876, it is true, the L.A.C. had been compelled to hold their meetings, which were the most important apart from the Championships, at Lillie Bridge, but there was some dispute over gate-money arrangements in that year, in which the L.A.C. held six meetings at Lillie Bridge, one at Richmond, and one at Hendon for swimming, besides sending an international team

to Ireland, which defeated the home side by nine events to four. Of the L.A.C. members in that year Sir Montague Shearman (now President of the A.A.A.) won the 100 yards Flat Championship, J. H. A. Reay was second in the 120 yards Hurdles, and J. H. Douglas and H. Davenport won the Middle-Weight Boxing and a Swimming Championship respectively. The income of the L.A.C. in 1876 was £1,221 2s. 10d., and in 1877 they moved into their own ground at Stamford Bridge, which is still the home of the famous club.

At that time two very astute brothers, James and William Waddell, filled the posts respectively of Hon. Treasurer and Hon. Secretary to the L.A.C. A sum of £2,899 11s. 10d. was required to secure the lease of the Stamford Bridge ground, and that sum was raised by means of £2,000 in subscriptions, a certain amount in debentures, and the rest loaned temporarily by the enthusiastic brothers. That year members of the L.A.C. carried off no fewer than eight of the twelve English Championship titles.

The question of a suitable home for the L.A.C. settled, the brothers Waddell turned their attention to a matter of even greater importance and took the lead in a strong agitation for a summer championship meeting. Protracted negotiations followed, but proved fruitless, and in the end the L.A.C. members to a man agreed to boycott the spring championships of 1879 at Lillie Bridge and to hold an opposition championship meeting at Stamford Bridge in the summer. In consequence of this action the spring championships were confined almost entirely to University men and a few provincials, while the summer fixture, which was supported by the Midlands, but not by the North, was rather a frost, despite the popularity of W. G. George, who competed in and won both the one and five miles races.

The reason for the holding aloof from both meetings of the North of England must be explained. In 1879 the Northern Counties Athletic Association, comprising some sixteen strong clubs, had been formed, and, incidentally, is, therefore, in the anomalous position of being senior to its present governing

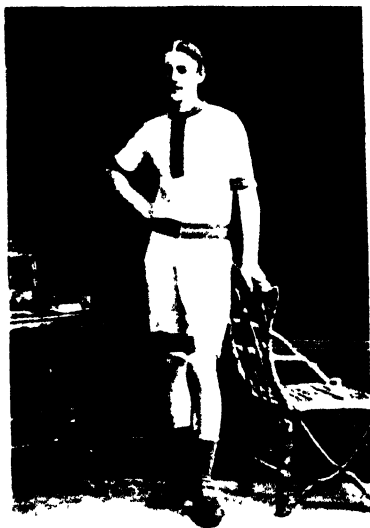

PL. 1] OLD TIME CHAMPIONS.

[B 10

1. C. L. Lockton, L.A.C., hurdler, sprinter and long jumper of the seventies. 2. The Hon. M. J. Brooks, O.U.A.C., Oxford and Cambridge High Jump Record holder since 1876. 3. E. H. Pelling, L.A.C., British Record holder 250 yards. 4. The late Walter Rye, L.A.C., English 7 miles walking champion, 1868.

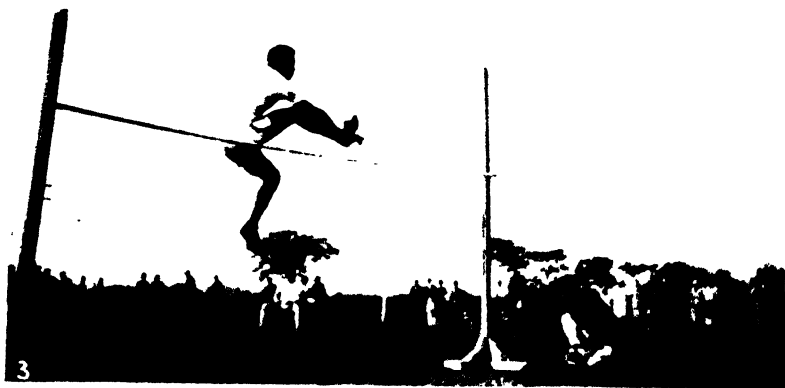
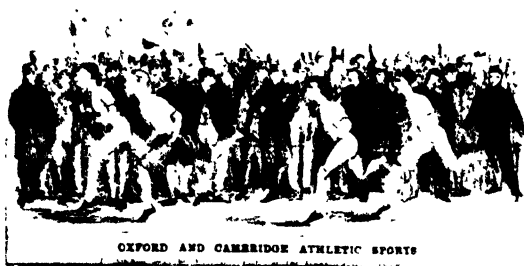

- PLATE 2 OLD TIME MILERS — C. C. Upson, C. C.
 1. R. F. Webster, Ford Abcrstone, C. C. A. C., beating the Earl of Jersey,
 O. U. A. C., in the Inter Varsity mile, 1895
 WHICH IS HIS PROPER EVENT?
 2. J. E. London, E. U. A. C., winning his first sprint in 10 secs.
 3. J. E. London, who has cleared 6 ft. 2 in., jumping

body, which is the Amateur Athletic Association, founded in 1880. The contention of the Northerners was that the championships should be open to any amateur who had never competed for money, no matter what his social status might be. To this proposition nine or ten Midland clubs, who were in process of forming their own governing association, rallied when the spring championships for 1880 were again advertised, and the Londoners again announced it as their intention not to take part. A deadlock appeared to be imminent until the Oxford athletes themselves suggested that there should be held a conference of all interested parties. Invitations were duly dispatched in the joint names of the Oxford and Cambridge clubs, requesting the secretaries of all duly constituted athletic clubs to meet at Oxford on April 24th, and the advertisements of the spring championship meeting were withdrawn, pending the holding of the Oxford Conference.

The difficulties of the Oxford sportsmen, who were genuinely anxious to bring into being a properly constituted governing body, were by no means ended with the issuing of the invitations to a conference. No one wanted to attend the meeting, unless there was some sort of guarantee that the wishes of his party would be considered favourably, and even from the C.U.A.C. there was some opposition to the conference taking place. In the end most of the objections were met or smoothed over, and Messrs. B. R. Wise, C. N. Jackson and M. Shearman, of the O.U.A.C., drafted a set of resolutions to place before the meeting, upon which they further sought the advice of Mr. Walter Rye, of the Thames Hare and Hounds Club, before the Conference took place.

The Conference was attended by twenty-seven delegates, representing sixteen Northern and nine Midland clubs forming the associations of these districts, and also fifteen other clubs. Mr. B. R. Wise, President of the O.U.A.C., occupied the chair, and there were present Messrs. J. G. Chambers and A. G. Payne (A.A.C.), L. Knowles, R. H. Macaulay and E. Storey (C.U.A.C.), C. Herbert and H. Tomlinson (Civil Service A.A.), J. Macqueen (German Gymnastic Society), J. Waddell (L.A.C.), J. Anderton

Athletics of To-day

and F. Smith (M.C.A.A.A.), R. Mullock (Newport A.C.), T. M. Abraham, C. E. Barlow, H. C. Faram and T. G. Sharpe (N.C.A.A.), J. Ingram (Northampton A.C.), J. E. Fowler-Dixon and C. F. Turner (North of the Thames C.C.U.), W. N. Bruce, C. N. Jackson and M. Shearman (O.U.A.C.), J. Suddaby (Reading A.C.), J. Gibb (S.L.H.), W. Rye (Thames H. and H.), W. Waddell (United Hospitals A.C.), and E. R. Wood (Woodbridge A.C.). After due deliberation it was agreed that the English Championship Meeting should be a summer fixture and should be held annually in turn in London, the Midlands, and the North. Another bone of contention that was buried was that relating to the amateur status, it being agreed that future championships should be open to all athletes who had never competed for money. The exact wording of the resolution defined an amateur as "Any person who has never competed for money with or against a professional for any prize, and who has never taught, pursued, or assisted in the practice of athletic exercises as a means of obtaining a livelihood." Following upon the acceptance of these and some other resolutions, the Earl of Jersey was elected President; B. R. Wise, Vice-President; C. N. Jackson, Honorary Treasurer; M. Shearman, Honorary Secretary, and the following seven gentlemen were appointed as a Committee: Messrs. Anderton, Barlow, Herbert, Lockton, Macaulay, Rye and Waddell, on which the other officers were to serve as *ex officio* members. Thus the Amateur Athletic Association was brought into being. Six years later it had in affiliation some 154 clubs, representing about 20,000 athletes, and to-day its affiliated clubs number upwards of 900 and must represent at least 100,000 athletes.

Meanwhile the propaganda of sport was spreading in other parts of the globe. We have evidence that during the middle period of the eighteenth century the gentlemen of America were accustomed to compete against each other in manly games, for is it not recorded that George Washington beat all his opponents at the running long jump? This episode provided, no doubt, an early forecast of the future prowess of American field events men.

The Growth of Modern Athletics 19

In 1844 the first great American sprinter was George Seward, of New Haven, Connecticut, who came to England and made some remarkable records ; there was also Billy Jackson, known as the " American Deer," and, in 1863, we were visited by L. Bennett, a full-blooded Seneca Indian, whose pseudonym was " Deerfoot," and he is said to have run 12 miles in 1 hour 2 mins. 2½ secs. In 1878 the Canadian, C. C. McIvor, sprint champion of America, came to England, but failed to beat the best of our professional talent.

During the history of American athletics there have been two periods of remarkable activity. The first, but a brief one, was from 1870 to 1878. The early troubles of the United States in matters of administration seem to have borne a remarkable similarity to our own. The Inter-Collegiate A.A.A.A. was founded on December 5th, 1875. Its first meet was in June, 1876. For two years prior to this, however, there had been a meet of colleges associated with the Inter-Collegiate Rowing Regatta. These meets were held at Saratoga, N.Y. Colonel G. Creighton Webb was the founder and first president. For many years the meets were held in New York City, but since 1904 have alternated between Philadelphia and Boston. In 1876 the National Association of Amateur Athletes of America and also the Western Inter-Collegiate Association were formed. In that year both the American National and the American Inter-Collegiate Championships were founded, and new clubs sprang up almost every week in the neighbourhood of New York City. More than a dozen sports meetings were held weekly from Washington's birthday up to Thanksgiving Day, and on one occasion each of two meetings held on the same day numbered nearly 800 entries, representative of upwards of 150 clubs.

This pace of progress was too rapid to be maintained, many clubs died a natural death, others were absorbed by their neighbours, and in 1880 there was trouble, which, as in England, caused the holding of two championship meetings. This resulted in the decease of the N.A.A.A.A. and the formation of the Amateur Athletic Union of the United States, which is allied with the Canadian A.A.A., although the two countries

hold independent championship meetings. Unlike the English governing body, which confined its attention to its own branch of sport, the A.A.U. holds jurisdiction over the associations governing basket-ball, billiards, boxing, fencing, fives, gymnastics, lacrosse, swimming, and wrestling, this system of central control and decentralised administration being favoured, as will appear, with equal success in Europe.

There is a vast difference between the organisation of University sport in England and America. In England there is no official control on the part of the University authorities, whereas in the United States the undergraduate athletic committees are subordinate to the general control of faculty committees, which have the power to prohibit the participation in sport of any undergraduate who has not attained a certain degree of scholarship.

In 1902 the second American athletic revival took place. The enthusiasm rose as suddenly as before and certainly led to many abuses. Play in the team games became unduly rough, there was an all too evident desire to win at all costs in individual contests, and the money which poured in from gate receipts led to an extraordinary luxury in training quarters and equipment. For example, in December, 1905, the Yale Athletic Association had in hand a surplus of no less than £20,000, after deducting the most colossal sums for expenses.

In 1906 many of the most important institutions, including the Universities of Harvard, Yale, Pennsylvania and Princeton, entered into a new agreement whereby an undergraduate should not be allowed to represent his University until he had been in residence for one year, nor continue to compete for his side for more than three years. The main object of this agreement was to discourage the practice of offering to promising boys, generally at preparatory schools, material advantages as an inducement to become students at certain universities. In fairness to the American nation it must be said that they have used every endeavour to keep their sport clean and healthy, and they have so well succeeded that America is to-day undoubtedly the first athletic nation in the world.

The Growth of Modern Athletics 21

The progress of Australia and New Zealand may be taken as typical of the growth of athletics throughout the Empire overseas. The sport in both countries is now governed by the A.A.U. of Australia and New Zealand, but prior to the formation of the Union three Australian Championship Meetings were held under an agreement made between the New South Wales, New Zealand, and Victoria Associations. The first championship meeting took place on the Melbourne Cricket Ground in 1893.

In connection with the Championship Meeting of 1897 at Sydney a conference was held, at which the present A.A.U. of Australia and New Zealand was formed, but the rules for competition were not drawn up and passed until two years later, when a further conference took place at Brisbane.

Space will not permit of my dealing with the historical development of every nation, and I think, therefore, that a short discussion on the progress of Sweden must serve as representative of athletic development throughout Scandinavia and the continent of Europe in general.

Athletic competitions and games, such as running, jumping, javelin-throwing, wrestling, ski-ing, swimming, etc., have formed a part of Swedish life since the days of the Vikings, at which period the Northern Games provided a counterpart to the Greek Olympiad, and may even have gone as far back as to be considered contemporaneous with the Taitin Games.

During the seventeenth century, and probably earlier, the standard of physical fitness in Sweden certainly stood high, but with the end of the period of Swedish political greatness, a general decline in the desire for physical efficiency was clearly evidenced.

Early in the eighteenth century Per Henrik Ling laid the foundation of a common-sense system of physical training in the Swedish schools, but the cult did not spread to the adult population until the modern athletic movement made its way into Sweden in 1880. From that year athletic sports have progressed enormously in Sweden, until they have now become

Athletics of To-day

one of the most important social factors. To-day, almost every factory of note has its own club and its own training ground, as I have seen for myself, athletics being indeed considered as among the best solutions of the problem of providing healthy and suitable recreation for the working classes.

The first athletic club was formed in Sweden in 1882, and by 1891, in which year the Swedish Gymnastic and Athletic Association was formed in Stockholm, there were over a hundred clubs interested in athletics in existence. The Swedish Athletic Association—the Svenska Idrottsförbundet—was formed two years later, and in 1896 the first Swedish Championship meeting was held.

The growth of general sport in Sweden has followed somewhat original lines, leading to the institution of a central association, rather like the A.A.U. of America, which controls all forms of competition. Each sports club is affiliated to the association corresponding to its own particular branch of sport ; but, in order to further the progress of sport as a whole, the clubs are united into general district associations which are affiliated to the great National Federation.

The Swedish National Sports Federation has a membership of about 1,000 clubs with a total of over 120,000 members.

The foundation of athletics in Germany, which country is rapidly improving and will soon challenge America's supremacy, is especially interesting to Englishmen. In 1873, W. Sapt, schoolfellow of the great M. J. Brooks at Oakfield House Preparatory School and Rugby, went with G. C. H. Brown, of Eton, to Dresden to learn German. The following is Mr. Sapt's own description of how the first football club was founded and of the first athletic meeting held in Germany :

“ Seeing many young Englishmen and Americans about,” writes Mr. Sapt, “ we decided to form a football club. We asked the English parson, Rev. T. B. Gilderdale, to take the matter up. A well attended meeting took place at his house. Rules were debated. I wanted the Rugby game, Brown the Eton.

The Growth of Modern Athletics 23

Finally, we compromised. We played Rugby with the proviso that you could not run with the ball unless you caught it full toss or first bounce. This made a capital game with plenty of dribbling and running. Later, after I had left Dresden, the Rugby game was adopted.

"The Club was a success from the start. We soon had about eighty members, and though there were no foreign opponents we had capital games among ourselves. We asked Heidelberg University to get up a team and play us, but a severe frost (the Elbe was frozen over) prevented it.

"The D.F.C. was, I believe, the first club of its kind on the Continent; certainly the first in Germany. Our members included English, Americans, French, and a Russian Prince, Nicholas Troubetscoy, who was a very nippy half-back. No Germans joined. They were inclined to ridicule the club, and often the words '*Apfen-Theater*'—Monkey Theatre—were inscribed on fences near our ground, which was in the Grosse Garten.

"The football having been a success, I suggested we should arrange an athletic sports meeting. This was done, every one liking the idea. Fixed for March 14th, 1874, bad weather caused this to be postponed twice, and it ultimately took place on March 22nd. I can find no record of an earlier meeting on the Continent. The meeting was attended by a large crowd and was very successful. The W. C. Gaye, who won so many events, was an old Highgate School boy. G. H. Urmson, the Judge, was the Oxford Blue, who won the 100 Yards and Quarter Mile against Cambridge. In the second year, April 1st, 1875, the meeting was even more successful. A large gathering included the King and Queen of Saxony—two splendid people who had a great liking for England and things English—and the Queen kindly distributed the prizes. The meeting became an annual affair; how often it took place, I cannot say, but it went on for a long time."

Mr. Sapt, Mr. Gaye, and Prince Nicholas Troubetscoy were among the most prominent of the performers. Germany, it is

true, ridiculed early English ideas of sport, but to-day the study of athletic science is being prosecuted more earnestly in that country than anywhere else.

In England we have no organisation that in any way corresponds with the system in vogue in America and Sweden, but the work of the Amateur Athletic Association is tending gradually towards decentralisation. There are District Associations in the North and Midlands and a strong Southern Committee. These are important institutions of old standing. The County movement in athletics is a more recent product. It originated from the Report of the Reconstruction Committee, appointed by the Amateur Athletic Association towards the end of the Great War, which suggested that a County Athletic Association should be set up in each county for the purpose of encouraging and directing athletic sport in the county and to hold County Championships.

The A.A.A. adopted the Reconstruction Committee's report and in 1924, at the proposal of Mr. Wallace R. Hare, of Buckinghamshire, the A.A.A. Counties Association Committee considered the advisability of holding an Inter-County Team and Relay Championship as an incentive to the County movement. There were then eight counties holding championship meetings of their own, and in August, 1925, the first Inter-County Championship Meeting was held at Stamford Bridge, London, and proved a great sporting success. This success led to the formation of county associations throughout practically the whole of the Southern area, but matters moved much more slowly in the Midlands, and the North continued to hold completely aloof from the movement. In connection with the first Inter-Counties Cross-Country Championship at Beaconsfield, in 1926, a meeting of county representatives was held and the Counties Athletic Union formed to take over the duties of the A.A.A. Counties Association Committee. It is early days yet to speak of the utility of the C.A.U., but that it has in its hands the power to regenerate English athletic sport is a self-evident fact, provided its progress is planned upon common-sense principles.

The Growth of Modern Athletics 25

For the proper understanding, however, of this history of athletics it will be necessary for us to go back a good many years. There is one peculiar circumstance about our English Championships which, although imposing a very real hardship upon some British athletes, who would be justly proud of a championship title, yet gives us the opportunity, year by year, of measuring our native prowess against some of the best men the other nations are able to produce. The fact is that the English A.A.A. Championships are open to the whole world, while competitions at the meetings of other nations are confined to men of each nation in question. This state of things has, undoubtedly, had an adverse effect upon English athletics, although not so much upon the track as in the field events, in which the foreigners have gradually become our masters.

A great many of our English titles have gone abroad as the years have passed, but many of those that were lost would most certainly have remained at home had the University men continued to support the championships as they did at first, and as they now again are doing. From the year 1880, in which the championship meeting ceased to be held in the spring, we find the letters O.U.A.C. or C.U.A.C. appearing more and more rarely after the names of the winners of championship honours, until we come to the post-War period, of which I shall write more fully a little later on.

It is easy enough to understand the desire of our athletes to meet those of other nations in the early days of organised athletics, for at that time international athletic matches, except for fixtures like the one in which a L.A.C. team made a successful raid upon Ireland in 1877, were hardly thought of. From the early nineties onwards the case was entirely different. Between 1887 and 1891 teams from the Manhattan A.C. and the New York A.C. visited England for the purpose of competing at the A.A.A. Championships. But I think the first real team test with an international flavour must be adjudged the match at Queen's Club, London, on July 16th, 1894, when Oxford University defeated Yale University, U.S.A., by 5½ events to 3½ events. In the following year Cambridge Univer-

sity met Yale at New York on October 5th and were defeated by eight events to three.

Two weeks prior to the holding of the above match a contest of even greater importance had been decided in New York City between the New York A.C. and the London A.C. It was a broiling hot day, but that circumstance did not prevent some 12,000 enthusiastic Americans from making their way to Manhattan Field on that famous 21st of September, 1895, to see their countrymen make a remarkable attack on records and achieve a signal victory. I have not space for a full description of that epic struggle, nor even of the wonderful quarter-mile race, in which the great American runner, T. E. Burke, defeated the plucky Oxonian, G. Jordan, by inches. Let the performances speak for themselves. World's records were made in the 220 yards, 21 $\frac{3}{8}$ secs. ; Half Mile, 1 min. 53 $\frac{2}{8}$ secs. ; Running High Jump, 6 ft. 5 $\frac{5}{8}$ ins. ; and equalled in the 100 yards, 9 $\frac{1}{8}$ secs. The other results were 440 yards, 49 secs. ; 1 Mile, 4 mins. 18 $\frac{1}{8}$ secs. ; 3 miles, 15 mins. 36 $\frac{1}{8}$ secs. ; 120 yards Hurdles, 15 $\frac{2}{8}$ secs., which would have been a world's record had the winner not knocked over one of the hurdles ; Long Jump, 22 ft. 6 ins. ; Shot Put, 43 ft. 5 ins. ; and Throwing the Hammer (old pattern with wooden handle), 137 ft. 5 $\frac{1}{2}$ ins.

No matter how strong a team the L.A.C. had got together, it is doubtful if they could have overcome the world-beaters of the New York A.C., but it is only fair to the London club to state that they lacked the services of E. C. Bredin, half miler, F. E. Bacon, miler, Denis Horgan, shot putter, C. B. Fry, who, two years before, had raised the world's Long Jump record to 23 ft. 6 $\frac{1}{2}$ ins., T. M. Donovan, another great "lepper," and J. M. Ryan, who was very nearly the equal of M. F. Sweeney, the high jump record breaker of the New York meeting, for Ryan himself accomplished 6 ft. 4 $\frac{1}{2}$ ins. in Ireland in the following month.

The meeting of September 21st, 1895, was undoubtedly the first impulse to the international matches which have now become so general. For example, the yearly triangular match between England, Ireland, and Scotland finds its counterpart

The Growth of Modern Athletics 27

upon the Continent in the annual *Landskamp*, at which Norway, Sweden, and Denmark contend for the title of champion Scandinavian country.

Meanwhile an even greater impulse towards international competition was in process of gestation. In 1887 a famous Frenchman, Baron Pierre de Coubertin, visited England in search of a system whereby he could lead his countrymen to take such an active interest in physical culture as would tend to counteract the depression which ensued upon the crushing defeat inflicted upon France by Germany in 1870. During his stay in England the Baron quickly developed a great admiration for the English Public Schools sports system, and from that inspiration grew the desire to impart the English ideals of sport, not only to France, but to the whole civilised world by organising a meeting of the amateur athletes and other active sportsmen of all nations in healthy international rivalry every four years. It was a tremendous project—nothing short, in fact, of an attempt to revive the Olympic Games of ancient Greece in a form best suited to modern conditions—and the first steps towards its achievement were fraught with many difficulties.

Baron de Coubertin, however, remained undaunted by rebuffs and set-backs and, splendidly aided by Mr. C. Herbert of the English A.A.A., and Professor Wm. M. Sloane of the American A.A.U., he succeeded in convening a Congress, which was held in the Sorbonne University at Paris on June 16th, 1894. At this Congress there were present delegates from America, Belgium, England, France, Greece, Italy, Russia, Spain, and Sweden, while Australia, Bohemia, Germany, Holland, and Hungary sent messages promising their support in any future arrangements upon which the Congress should decide. The deliberations of the Congress resulted in the foundation of an International Olympic Committee, under the presidency of Baron Pierre de Coubertin, which resolved that Olympic Games should be held every fourth year in a different country. Colonel Balck, of Sweden, put in a strong claim for the initial celebration to take place at Stockholm, but Greece had premier rights, if only on grounds of sentiment, and the

first of the modern Olympiads was celebrated at Athens, 6th to 12th April, 1896, in the ancient stadium, which, fifteen hundred years before, had last been used for such a purpose. One may mention in passing that the stadium had been rebuilt to seat 45,000 spectators through the munificence of a Greek merchant, Mons. Averoff, of Alexandria, at a cost of over a million drachmas.

The athletic track and field events formed the basis upon which the great modern Olympic Games programme was constructed, for the simple reason that these sports do not form a national game peculiar to any one nation, and so afford greater facilities for the meeting of all parties on a common ground. Apart from athletics, however, there were contests in gymnastics, wrestling, pole climbing, lawn tennis, fencing, rifle and revolver shooting, weight lifting, swimming and cycling. These matters, extraneous perhaps to a history of athletics, are mentioned to give the reader some idea of the magnitude of a modern Olympiad. Practically the whole of the European nations were represented, besides America, Australia, and Great Britain.

At the time, however, the Olympic Games did not command the world-wide attention which is now accorded them, and in England particularly but little was known of the festival. In consequence of this circumstance Great Britain was but poorly represented; but had all our best men gone over to Athens there seems little doubt that we should have won the High Hurdles, Long and High Jumps, and the Shot Put, judging by a comparison of the Olympic results with those at the A.A.A. Championships. As it was, Flack, of the L.A.C., won both the 800 and 1,500 metres titles, Gemelin, O.U.A.C., was second to T. E. Burke, U.S.A. in the 400 metres, and Goulding was an unlucky loser in a slow hurdle race. Even America does not seem to have taken this first modern Olympiad very seriously, for the United States sent five men from Boston, and four from Princeton, who, although each winning an Olympic event, were not the holders of American Championship titles.

The Growth of Modern Athletics 29

The second Olympiad took place at Paris in 1900 and, owing to bad organisation, was not a conspicuous success. Of the athletic honours, America carried off seventeen, Great Britain four, and France and Hungary one each. The third Olympiad was held at St. Louis, U.S.A., in the summer of 1904, and an immense programme was decided. The European nations were almost entirely unrepresented, and America won every one of the athletic events, except Slinging the 56lb. Weight, which went to E. Desmarteau, of Canada.

In 1906 the Greeks, dissatisfied with the cosmopolitan character of the Games, decided to give the revival a more definitely Hellenic stamp and so instituted an additional series to be held at Athens in the middle of the quadrennial period. This meeting was held once and was a definite success, perhaps on account of the personal interest of the Grecian Royal Family and the presence of King Edward VII and Queen Alexandra and the Prince and Princess of Wales, but it has never been repeated, and indeed would prove too much of a drag upon the nations which already find sufficient difficulty in raising teams and the funds to send them to compete once in every four years at the orthodox celebrations of the Games.

A further celebration, within the regular Olympic cycle, took place in London, 1908. Marathon Day, July 24th, saw assembled at the Shepherd's Bush Stadium, the greatest number of spectators that has ever attended an athletic sports meeting in Great Britain, the nearest approach to the 1908 record being the occasion of the British Empire *v.* U.S.A. match at Stamford Bridge, London, on August 18th, 1928, when 41,000 people were present.

The next Olympiad was held at Stockholm in 1912. This constituted the best organised meeting that has yet taken place, and it was held at the most suitable stadium I have yet seen.

In the Olympic Games proper at the Fourth Olympiad (London, 1908), Great Britain scored twenty-five successes, including the victories of R. Walker, South Africa, in the 100 metres, and R. Kerr, Canada, in the 200 metres, while America

won eighteen events. In the running and walking events Great Britain scored six victories, while America won the Marathon, two flat races, and both hurdle races, and the British Dominions took the two sprints. In the field events however, Great Britain won only the Hop, Step, and Jump, as against America's nine titles and Sweden's two.

By the time of the fifth Olympiad, Finland, Sweden, Norway and Denmark had become definitely athletic nations, and France, Germany, and the lesser European countries were all showing steady progress. At Stockholm the Americans, although winning again, found their supremacy strongly challenged, especially by Finland and Sweden.

The sixth Olympiad was destined for Berlin in 1916, but never took place. The Great War might have been expected to prove such a set-back to the contestant nations that any thought of holding the seventh Olympiad in its proper year, 1920, would have been deemed impossible. The keenness of the late Rev. R. S. Courcy Laffan prevailed so far as Great Britain was concerned, and we have to thank the London A.C., that bed-rock upon which British athletic sport was built up, for a great work that was carried on during the War. There were, of course, many members of the L.A.C. who were too old or otherwise unfit for active service, and these men saw to it that athletic sport in our English nurseries, which are the public schools, was kept healthy and vigorous by the carrying on of the Public Schools Championships in the years between.

These Championships deserve a chapter to themselves, but, as it is, a few words must suffice. All over the world the movement for the better sporting education of juvenile athletes has been making steady progress during the last thirty or forty years. In America the universities and colleges, as well as all the high schools of any standing, have properly qualified athletic coaches. In 1906 the Schools Athletic League of New York came into being, and upwards of 8,000 boys take part in its annual championship meeting, while anything up to 3,000 boys take part in the elementary schools indoor championship gathering.

The Growth of Modern Athletics 31

In Sweden there is a meeting which must be unique of its kind. This is the Swedish Schoolboys' Athletic Week, during which championships are decided annually in Stockholm. France, of course, has established a Ministry of Sport, and in Germany, Hungary, and many other countries the progress of the schoolboys is carefully planned and as carefully watched and assisted.

In Scotland and the Dominions Overseas Inter-Scholastic Championships have been long in vogue. In England athletic matches have been held between certain schools for a number of years, and we have the Public Schools Challenge Cup Meeting, promoted each spring by the L.A.C., which serves really as a Public Schools Championship Meeting, the Public Schools Cross-Country Race, promoted by the Ranelagh Harriers, and the Public Schools Relay Meet, held under the auspices of the Achilles Club.

In 1925 there was founded through the help of the *Daily Express* the Schools Athletic Association, of which H.R.H. The Duke of York is President. The primary objects of the S.A.A. are the physical, mental, and moral training of boys and girls at the elementary schools. The association, which is growing steadily, holds a huge championship meeting each year, and in 1928 there were affiliated to the S.A.A. some twenty-five counties, representing a constituency of three or four hundred thousand children of both sexes.

Another great factor for our future progress is to be found in the system, instituted by the Bedfordshire A.A.A. in 1927, of promoting County Junior and Colts Championships for boys under seventeen and under fourteen years of age respectively.

The Public Schools Challenge Cup Meeting, which justly should be styled the Public Schools Athletic Championship Meeting, was not the product of any sudden inspiration, but is rather the logical outcome of a perfectly natural process of evolution. In 1890, Mr. C. H. Mason, L.A.C., who won the English One Mile Championship of 1872, presented to the club a quarter mile challenge cup to be competed for annually by Public School boys. In 1896 two further cups were presented,

but the entries for the three events numbered less than forty. The following year a number of members presented still more new cups, in commemoration of the late Queen Victoria's Diamond Jubilee, and the number of events was increased to eight. By 1928 the total had reached a dozen events, and there were 541 entries, representative of over half-a-hundred schools. In 1929, Throwing the Javelin and Throwing the Discus, events at which English athletes have proved extraordinarily inept, were added to the programme, in the hope that their practice at the schools will produce better results from British throwing men of the next adult athletic generation.

The fact that the L.A.C. kept this important meeting going throughout the War period has, undoubtedly, had much to do with the production of the fine teams of athletes we were able to send as the representatives of Great Britain to the post-war celebrations of the Olympic Games at Antwerp, 1920, Paris, 1924, and Amsterdam, 1928. At these three Olympiads, incidentally, Great Britain and the Dominions have done far better than did their forebears of the pre-War period.

Another factor which must be held largely accountable for the improved position of Great Britain in international athletics is the much more prominent part taken nowadays in athletics by the University type of athlete. In 1919 there was constituted the Inter-University Athletic Board of Great Britain and Ireland, on which were represented the provincial Universities of Aberystwyth, Bangor, Birmingham, Bristol, Cardiff, Durham, Leeds, Liverpool, Manchester, Nottingham and Sheffield. This led to the tilling of a field, hitherto almost untouched. In due course, London and other institutions rallied to the movement, which included the holding of annual I.V.A.B. Championships, and a high standard of performance has now been reached.

Here we may pause to remark that it was through this particular medium that the sprinting ability of J. E. London (L.U.A.C.), who finished second in the Olympic 100 metres, 1928, was first discovered. In the spring of 1925, J. E. London was picked to represent his University in the High Jump



BRITISH EMPIRE & U.S.A., 1928



71 37

Shot and Goal 30 32

WASEDA UNIVERSITY & ACHILLES CLUB, 1928

HISTORIC TEAMS.

Japan was the first far-Eastern country to send a team to Europe. They were beaten by only 3 points.



Historic Skippers—J. W. J. Rinkel, Achilles A.C., and Yoshio Okita, Waseda University.



PL. 4]

Ambassadors of Empire Sport—Lord Desborough and Lord Burghley.



Sport and General. (1) 33

A great Sporting Trio—Evan Hunter, Hon. Sec, British Olympic Association, D. G. A. Lowe, and Lord Birkenhead.

against Bedford County at Bedford. One of the L.U.A.C. sprinters missed the train, and London, who volunteered to fill his place, won the 100 yards in ten seconds, on a level grass course, but whether he would have done better to stick to high jumping is a moot point, for he has cleared 6 ft. 2 ins. without any pretensions to a proper style. (Pictures of London winning his first sprint and high jumping at Bedford are Nos. 2 and 3 of Plate 2.)

The formation of the Inter-University Athletic Board—one of the most progressive steps of the post-War period, and one, moreover, which must have a great influence for good upon the future of British athletics—was something in the nature of the fulfilment of a pre-War dream, Dr. Edward Moir, N.C.A.A., of Manchester, being one of the prime movers in the plan.

There were other dreams also in the pre-War period. Tentative proposals had been put forward upon several occasions for the formation of a joint Oxford and Cambridge Athletic Club, similar in character to the Leander Club. With others, Kenneth Powell, C.U.A.C., and G. R. L. Anderson, O.U.A.C., had planned a definite attempt to found such a club in the winter of 1914. The War intervened and these two famous hurdlers fell in action. But others, also keen in the movement, survived, and on March 27th, 1920, the Achilles Club was founded.

One most important reason why this club was formed is to be found in the fact that for years past very few Blues had taken any part in national athletics, and those who formed the club were of the opinion that it was highly desirable that they should do so, and that an effective lead in that direction would be given by the formation of a joint Oxford and Cambridge Club. Membership of the club is open to all Blues and Half Blues and to all present members of the O.U.A.C., C.U.A.C. and C.U.H. and H., who shall be nominated by the Committees of the O.U.A.C. and C.U.A.C. respectively, but these present members, apart from Blues and Half Blues, may not number more than twelve in any one year.

Athletics of To-day

The objects of the Club are set out in Rule 2 of the Constitution which reads as follows :—

- “ (a) To encourage athletics among members of the O.U.A.C. and C.U.A.C. after they leave the University, and to provide them with suitable training grounds, accommodation, and coaching.
- “ (b) To enter teams for the A.A.A. Relay Championships and at open meetings, thereby providing the opportunity for past and present members of the O.U.A.C. and C.U.A.C. to compete together.
- “ (c) To encourage relay and team racing.
- “ (d) To organise international matches with Dominion and foreign universities and teams.
- “ (e) To arrange matches with the public schools.”

By 1929 the Achilles Club has acquired considerable influence, and practically all the aims and objects of its founders have been fulfilled. As a result of its example and initiative, inter-school, inter-college, and inter-club matches on the relay and team principle have greatly increased in number. Its members have gained many points for British Empire teams at the Olympic Games at Antwerp, Paris, and Amsterdam. A considerable number of Oxford and Cambridge athletes are now taking part in national athletics, and thirty-nine A.A.A. Championship titles have been captured by Oxford and Cambridge athletes since the War.

Achilles teams have carried out noteworthy tours in many foreign parts, including Central Europe, Germany, and Greece, but one of the most interesting events in the history of international inter-university contests took place at Stamford Bridge, London, on July 10th, 1928, when the Waseda University Team, of Tokio, Japan, met and were beaten by the Achilles Club, but only by the narrow margin of three points. At this meeting the performances of the Japanese field events men were truly remarkable, R. L. Howland, C.U.A.C., who took the shot put, being the only field events Blue who was good

The Growth of Modern Athletics 35

enough to win an event. The Japanese runners and hurdlers too shaped remarkably well.

Another great factor in the development of British athletics is to be found in the remodelling of sport in the Services. Twenty years ago the majority of rank and file athletes in the Army were professionals, the prizes at regimental sports being invariably in cash. All that has been altered since the War, and to-day the soldier who embraces professionalism can find no playmates inside the Service. I well remember in the Aldershot Command of pre-War days the paucity of sports grounds. But in 1929 there are 107 football and hockey grounds, 27 cricket pitches, and 90 tennis courts, to say nothing of the splendid Central Athletic Ground, which, with maintenance, etc., has cost upwards of £72,000. The money, however, has been well spent, since the Army is beginning to give us many first-class athletes.

Both in the total of entries and in the standard of performance an exceptionally high level was maintained at the seventh Olympiad held at Antwerp in 1920. The successes of the British Empire in the 400, 800 and 1500 metres individual races and in the Steeplechase and 1600 metres Relay were not the only surprises of that Olympiad, for it was only through the adventitious re-introduction of the 56lb. Weight Slingshot event that America avoided sharing the premier honours in athletics with Finland.

At Paris in 1924 British improvement was even more pronounced. New world's records were established by Eric Liddell, Great Britain, 400 metres, 47 $\frac{3}{4}$ secs., and A. W. Winter, Australia, Hop, Step, and Jump, 50 ft. 11 $\frac{1}{4}$ ins., while H. M. Abrahams, Great Britain, equalled the Olympic 100 metres record of 10 $\frac{3}{4}$ secs., and D. G. A. Lowe won the 800 metres. Upwards of 2,000 athletes from forty-five nations took part in the athletic section of the programme, and the highest level of achievement that has ever yet been aimed at was attained. The United States, her national confidence a little shaken by the experiences at Antwerp, sent to Paris what was probably the greatest team of super-athletes that has ever been

assembled. In twenty-seven events these Americans scored twelve first places and made five of the nine new world's records. Of the five new Olympic records the United States established two, and one of the two marks equalling previous Olympic records was made by an American.

Finland was again America's greatest rival for athletic supremacy, and, although the Americans won back many of their field events laurels, the three Finns, Paavo Nurmi, Willie Ritola, and Albin Stenroos, outclassed all opposition in the distance races from 1500 metres to the Marathon race of 26 miles 385 yards.

The ninth Olympiad at Amsterdam in 1928 will go down in history as the celebration at which special events for women athletes were first included. The meeting was notable also for numerous other reasons. Japan and the athletically lesser known nations made their presence felt in no uncertain manner. Canada produced a team that amazed the world, and their nineteen-years-old schoolboy, P. Williams, won both sprints. South Africa was but little behind her sister Dominion, and the British team again claimed two titles, D. G. A. Lowe retaining his 800 metres laurels, and Lord Burghley taking the 400 metres Low Hurdles. Finland not only gained victories through her veterans, Nurmi and Ritola, but produced also a new generation of runners who proved themselves unbeatable. America collapsed with her track stars, but again did well in the field events, and Germany never failed to push America hard for premier honours, but her athletes, new to Olympic competition, from which their country had been debarred since 1914, appeared to be completely over-awed by the greatness of the occasion. In the course of the Olympiad four world's records were beaten and one equalled, and of the Olympic records ten were broken and one equalled, a marvellous series of achievements, in view of the condition of the track and the state of the weather. The final placings and points are given in a table in the Appendix.

Apart however from all questions of who won or lost and the merit of actual performances, it must be noted that the athletic

The Growth of Modern Athletics 37

section of the ninth Olympiad was absolutely free from untoward incident and that the friendliest spirit between all nations was the keynote of this particular celebration.

There is no doubt in my mind, as I pen these words, that we have progressed so far along the road of athletic achievement that our forefathers of the early sixties would stand no chance at a modern championship meeting. But, perhaps best of all, it is equally clear that the whole world is working slowly but surely towards that ideal of Baron Pierre de Coubertin who said in 1894, "Before all things it is necessary that we should preserve in sport those characteristics of nobility and chivalry which have distinguished it in the past, so that it may continue to play the same part in the education of the peoples of to-day as it played so admirably in the days of ancient Greece."

One important outcome of the Olympic Games affecting directly the English-speaking peoples was the institution in 1920 of a match to be held every fourth year immediately after the Games between the combined strength of the whole British Empire and the pick of the American Olympic Team. The first of these matches, run entirely on the team and relay principle, resulted in a draw, but America won the next two. On each occasion British or world's records were broken; but neither victories nor records are important when compared with the wonderful understanding and excellent good comradeship which these matches have engendered between the flower of the young manhood of America, Great Britain, and the vast Dominions overseas. This good fellowship is about to result in the formation of a British Empire Sports League, which will lead to the holding of British Empire Games in every fourth year between the Olympiads in either Great Britain or one of the Dominions. The first celebration is being planned to take place at Hamilton, Canada, in August, 1930

PART II—The Track Events

CHAPTER II

THE SPRINTS—100 TO 300 YARDS

RUNNING, considered as a sport, provides the most primitive form of exercise and has been in vogue from the earliest times. An event in the Olympic pentathlon of the ancient Greeks was the simple foot race (*δρόμος*), a little over 200 yards in distance, one length of the stadium course, and was run straight from start to finish. No record of the times returned by the Greek runners has come down to us.

“Sprinting” is the generic term applied to the running of such short distances as a man can cover at top speed in one continuous effort. The distances and conditions of running are now stereotyped, and 300 yards has been determined as the limit of sprinting distance. For many years the belief prevailed that no special set of physical attributes distinguished the sprinter from any other type of athlete. By the early eighties of the last century however, athletic authorities had come to recognize as characteristic of men capable of producing great speed for a short distance such attributes as large muscular thighs and a broad back, and as long as a man “stripped big” nothing else was held to matter. It was, however, understood that the front muscles of the thigh, which bring the leg forward, were the more important to the sprinter, since speed depends upon the rapid repetition of the stride.

In 1903 Dr. Phillips, of Amherst, U.S.A., made an exhaustive study of the physical make-up of seventy-four first class sprinters in an attempt to ascertain from what source sprinting power is derived. His observations, combined with the measurements he took, suggest the following combination of qualities as typical of the ideal sprinter :

1. A skeleton rather lighter and taller than the average.
2. A brachycephalic head, *i.e.* a skull that is short and broad.

The Sprints—100 to 300 Yards 39

3. Narrow hips.
4. High insteps and short feet.
5. Muscular development above the normal in both size and strength of muscle.

To Dr. Phillips's observations must be added a note concerning the experiments of Professor A. V. Hill, F.R.S., of the University of London, who has recently taken a keen interest in the scientific aspects of athletic sport. The experiments in question were carried out at Cornell University, U.S.A., with an electrical timing apparatus of Professor Hill's own invention. In the section of his researches dealing with sprinting he had the practical help of H. A. Russell, of Cornell University. Russell in 1926 won the I.C.A.A.A. 100 yards in $9\frac{7}{10}$ secs. and the 220 yards in $21\frac{2}{3}$ secs. and retained the latter title in 1927 in 21 secs. flat. This being so, it is reasonable to suggest that this sprinter was a fair subject for a series of speed experiments. At Professor Hill's request Russell ran 200 yards in one continuous burst at the maximum speed he could produce, and I have set out hereunder the schedule of his times as they were recorded electrically. It should be noted that the first 100 yards were covered in $9\frac{8}{10}$ secs. and the second 100 yards in $9\frac{5}{10}$ secs.

SCHEDULE FOR 200 YARDS RUN BY H. A. RUSSELL, CORNELL UNIVERSITY, ELECTRICALLY RECORDED BY PROFESSOR A. V. HILL, F.R.S.

Yds.	Secs.	Yds.	Secs.
1	0.36	80	8.12
3	0.75	100	9.88
6	1.20	120	11.69
10	1.71	140	13.55
15	2.27	160	15.45
20	2.76	180	17.42
40	4.59	200	19.45
60	6.38		

Athletics of To-day

His rate of speed at various points was as follows :

At yds. from start	Yds. per second	Miles per hour
30	10.90	22.3
50	11.14	22.8
70	11.46	23.5
90	11.37	23.3
110	11.04	22.6
130	10.78	22.0
150	10.50	21.5
170	10.16	20.8
190	9.85	20.1

As the result of his experiments Professor Hill arrived at the conclusion that a first class sprinter travelling at top speed uses up 90% to 95% of his effort in overcoming the frictional resistance of his own muscles. The force he exerts is equal to 80% or 90% of the weight of his body, and the amount of work he does in running 100 yards would be sufficient to raise his body 240 to 270 feet into the air. Approximately one second is lost in the starting process, approximately eight horse-power is developed and the maximum speed attained sixty or seventy yards from the start, when the man may be travelling as fast as twenty-four miles an hour. From the point at which the greatest velocity is reached the runner begins to lose speed through fatigue due to the rapid appearance of lactic acid in the muscles, as much as an eighth of an ounce of such acid being secreted in the muscle substance every second.

On these lines it would appear that a sprint effort sustained for 30 secs. should produce almost complete exhaustion, and yet neither B. J. Wefers, U.S.A., when he made the world's 300 yards record of 30 $\frac{1}{4}$ secs. in 1896, nor G. M. Butler, Great Britain, who equalled it in 1926, collapsed after passing the finishing post.

The Sprints—100 to 300 Yards 41

In the course of a 200 yards race run at top speed throughout, the athlete's pace decreases as much as 15% between 70 and 190 yards. The fact that Russell's second 100 yards was faster than the first was due, of course, to the one second lost in starting. This brings our coaches and other athletic experts to some pretty points for consideration. No means are known of delaying the appearance of lactic acid or of reducing the amount secreted. Something may be done by means of special developmental exercises in training to diminish the amount of muscle friction. But, meanwhile, the really acute problem is that of curtailing the loss of time at the start of the race.

Up to the year 1888 all sprinters had used the old standing up start. In this style the front foot was on the scratch line, the other foot some seven or eight inches behind it, the body was held leaning forward with chest almost parallel to the line. In May, 1888, however, C. H. Sherrill, Yale, who won one American National and seven I.C.A.A.A. sprint titles, produced an entirely new method of starting at a meeting held at Cedarhurst, Long Island. So novel was the position assumed by the athlete upon being told to "Get to your mark," that the starter thought Sherrill did not know how to start and so held up the race for some minutes to explain the matter to him. At last, however, the official was made to understand that a new start was being tried, and a moment later he saw how efficacious it was. That "Crouch Start," (See Plate 5), worked out by Charles H. Sherrill, in consultation with that *doyen* of American coaches, the late Michael Murphy, is in universal use to-day.

The method was first introduced into England in 1890 by the amateur champion quarter-miler, T. L. Nicholas, of Monmouth, but for a long time the tall, heavily built men, like the famous sprinter, E. C. Bredin, who tried it but quickly returned to the standing up method, believed that the crouch was only suitable to shorter and more lissom men than themselves.

I would here pause to point out that within two years of the invention of the new method, J. Owen, Jr., of Detroit,

Athletics of To-day

had reduced the American 100 yards Championship record to $9\frac{1}{8}$ secs., B. J. Wefers, Georgetown University, bringing the I.C.A.A.A.A. record down to the same figure in 1896. At the English Championships, however, such a time was never recorded until G. H. Patching, of the South African Olympic team, took the A.A.A. title in 1912, while even time was never beaten at the Oxford and Cambridge Sports until A. E. Porritt, O.U.A.C. recorded $9\frac{1}{10}$ secs. in 1925.

It now remains to be seen what new, and, one expects, revolutionary principle will be evolved for the production of yet faster times. It has been suggested that, since even and regular striding is inseparable from success in the jumps and high hurdle races, the sprinters would achieve better results by learning to cover the 100 yards distance in exactly the same number of strides each time they run it. Abrahams finished usually on his left foot, but added a stride in his two fastest races. Both he and Harry Hutchens strided $7\frac{1}{2}$ feet at top speed. A noted theorist advances the proposition that since of two men starting together, the one running and the other hopping, the one who hops will always be ahead at ten yards, after which the runner commences to catch him up, a series of experiments in hopping starts would probably lead to the discovery of a new form, provided the athlete can accomplish a smooth transition from a hopping action to a run within the initial ten yards. These suggestions seem far-fetched at first sight, but even more surprising propositions have proved practicable in the past, and something may yet be evolved along these lines.

As I have pointed out in earlier pages of this book, the 220 yards distance was not raised to championship status in England until 1902, and has never yet gained admission to the Oxford and Cambridge programme. There were, however, some good furlong men in the early days, as is proved by the annals of the L.A.C. Meantime our concern is with the 100 yards sprinters.

The first winner of the Oxford and Cambridge 100 yards

The Sprints—100 to 300 Yards 43

(1864) was B. S. Darbyshire, of Wadham College, Oxford, and the first English Champion (1866), T. M. Colmore, O.U.A.C. Both races were won in $10\frac{1}{2}$ secs.

At the same time Eton College produced a phenomenal schoolboy athlete. This was the late J. H. Ridley. In 1866 he won the English quarter mile in 55 secs. and the following year retained that title, returning $52\frac{3}{4}$ secs. He went up to Jesus College, Cambridge, and as a Freshman won the O.U.A.C. quarter mile in 51 secs. and the event against Oxford in exactly the same time. But from that year he seems to have abandoned athletics in favour of other pursuits.

In 1868 W. M. Tennent, of Liverpool, won the English title in $10\frac{1}{2}$ secs., and then came the first great ten years of University sprinters, among whom was the present President of the A.A.A., Sir Montague Shearman, O.U.A.C. (see Frontispiece.) In 1876 he won both the English Championship and Inter-University 100 yards in $10\frac{1}{2}$ secs. and in 1880 took the English quarter mile in $52\frac{1}{2}$ secs., his brother, J. Shearman, winning the same event in 1878 in $52\frac{3}{4}$ secs.

It was in 1878 also that a foreigner first captured an English title, L. Junker, a Russian member of the L.A.C., carrying off the 100 yards in $10\frac{1}{2}$ secs. His running career was brief but brilliant, for he was only once beaten in his two years of competition. When moving at speed he had the appearance of being terribly bandy-legged and ran with a stiff action, almost flat-footed. He stood 5 ft. $9\frac{1}{2}$ ins. in height and was very strongly built, his stiff action, I believe, being due to his great strength. There is an amusing legend which states that he came to take up running through being chaffed by some fellow business men in the city about his slow clumsiness, whereupon he challenged whoever might be deemed the speediest of his detractors to run him for a bottle of champagne. The bet was taken, Junker won hands down, and the secretary of the L.A.C., evidently as vigilant then as Mr. Lomax is to-day, recruited the Russian as a member.

Although Junker won the Championship of 1878, he never met his great contemporary, E. C. Treppin, Brasenose College,

Oxford, who was the best of the great University sprinters of that period. Treplin provided something of a special case among sprinters. He stood over 6 ft. in height and weighed all of 13 stone, but was incapable of staying a longer course than 150 yards although he could run that distance in 15 secs. flat. His action was ungainly, and he was inclined to lose direction, yet he won against Cambridge three times and returned 10½ secs. on each occasion. After Treplin's last win in 1879 the race of University sprinters was replaced by a host of great runners at the longer distances.

Meanwhile another amazing schoolboy had appeared upon the scene. This was C. L. Lockton, Merchant Taylors' School, now a Justice of the Peace for the County of Surrey. (His portrait is given on Plate 1, No. 1.) At the age of twelve he won the Class 3 school sprint, open to boys of twelve to fourteen years of age, in 13 secs. In 1872 at fifteen years of age he defeated J. Shearman very easily in 12 secs. and was then capable of holding his own in first class company. At sixteen years of age he took his school 100 yards in 10¾ secs. and won the English long jump championship at 19 ft. 4 ins., and thus, I fancy, holds the peculiar distinction of being the youngest English champion on record. Of his long jumping, however, I shall write more fully in a subsequent chapter. For a few years he rather lost his form, as immature athletes of too early promise often will do, but in 1879 he reached his real zenith, winning the English 100 yards in 10½ secs., the 120 yards hurdles in 16¾ secs., and the long jump at 22 ft. 1½ ins.

He was a beautifully proportioned, graceful runner and a magnificent all-round athlete. From 1869 to 1870 he won thirty-three out of thirty-four events at Merchant Taylors' School, besides dead heating in the shot put. His only defeat was in the high jump when he was beaten for premier honours by M. Shearman. In later years he was sometimes beaten by runners really inferior to himself upon the cinder path, notably in the championship of 1880, when W. P. Phillips, L.A.C. beat him by the barest of inches in 10½ secs., although Lockton had been timed over and over again in his trials as doing

The Sprints—100 to 300 Yards 45

“evens.” I think, however, that his biggest disappointment was in connection with Rugby football. At the age of sixteen he was chosen as a three-quarter for the South of England against the North at Rugby, but was unable to play because the headmaster refused to allow him time off on Saturday morning to get to Rugby, remarking that “it was no credit to the school.” Just after leaving Merchant Taylors’, Lockton was chosen to play three-quarter for England against Scotland, but had the misfortune to break his collar-bone two days before the match.

Phillips, who succeeded Lockton as sprint champion, was a magnificent specimen of manhood, but ran perfectly erect and secured his three championships by the barest inches. Unhappily he died of heart disease in 1883.

In the first year of Phillips attaining championship honours a new aspirant to the title, who had long since taken to spiked shoes, was achieving a great reputation. This was J. M. Cowie, L.A.C. There was nothing remarkable about his physique or early performances, but he possessed the will to win and the patience to perfect his form. He reaped his reward in the year poor Phillips died and continued to hold the title until 1866, when A. Wharton, of Darlington, at last achieved the coveted record of 10 secs. flat. He was, I believe, the first black man who ever won an English Championship.

Contemporary with Wharton was the great C. G. Wood, Blackheath Harriers, still living happily in Norfolk. Wood was not quite at his best at 100 yards, but won the English 440 yards twice, returning as his best time $49\frac{1}{2}$ secs. in 1886. His best distance, however, lay between 150 and 300 yards. Here he broke all the old records by running 150 yards in $14\frac{1}{2}$ secs., 220 yards in $21\frac{1}{2}$ secs. and 300 yards in $31\frac{1}{2}$ secs., all in 1887.

The following year two American Championship Meetings took place. F. Westing, Manhattan A.C., won both the old N.A.A.A.A. and the new A.A.U. titles, the latter in even time. He then came to England and was thus the first of his countrymen to capture an A.A.A. sprint championship.

Special mention must, I think, be made of E. H. Pelling, L.A.C. (No. 3, Plate 1), who won the Championship of 1889 in 10 $\frac{1}{2}$ secs. A tall, fine athlete, he was in many respects a cross between Treplin and Wood. Not quite so good as the former at a 100, and not, like the latter, capable of holding top speed at 440 yards, he yet found his best form at the odd distance of 250 yards, which he covered in 24 $\frac{1}{2}$ secs. at Stamford Bridge on September 22nd, 1888. Many sprinters have since attempted to surpass that record, but no one has succeeded as yet in even equalling it.

The beginning of the twentieth century brought to light the great A. F. Duffey, Georgetown University. In America he was up against Alva Kraenzlein and Maxey Long and never won either a national or inter-collegiate title, but in England he was unbeaten from 1900 to 1903 and returned even time for each of his wins. Duffey was a tremendously fast starter, and an amusing story is told of one experience with a North Country starter, who is said to have uttered a warning as he stood behind Duffey's curved latter end.

"Sitha, Duffey, lad," said the official, "Ah've brought shot gun for t' startin'. Ah've blank i't first barrel an't shot i't second. Tha canst guess where tha'll't get shot if tha tries any flyers."

J. W. Morton, South London Harriers, succeeded Duffey in the sprint championship and with M. Chapman, Finchley Harriers, was our big hope for the Olympic 100 metres, 1908. In 1902 the 220 yards was at last added to the A.A.A. Championship programme, and Morton and J. P. George, S.L.H., who had won the furlong title, 1907, in 22 $\frac{1}{2}$ secs., were fancied for 200 metres honours in 1908. Morton, however, had lost his form, and George was "favouring a leg."

At Shepherd's Bush, the Empire produced a couple of surprises. R. E. Walker, nineteen years of age, who stood 5 ft. 7 ins. and weighed 9 stone 4 lb., was not among the original South African selections, but was sent over from Natal for the A.A.A. Championships. He had won the South African 100 yards of 1907 in 10 secs., but was beaten in 1908 by E. J.

The Sprints—100 to 300 Yards 47

Duffey in $10\frac{1}{2}$ secs., although he won the furlong in $22\frac{2}{3}$ secs. In England he beat J. W. Morton at Birmingham, but succumbed to R. Kerr, Canada, in 10 secs. at the A.A.A. Championships, Kerr achieving a good double with the furlong in $22\frac{2}{3}$ secs. Of the Americans this pair of Britishers were up against, J. A. Rector (twenty-one years, 5 ft. $11\frac{1}{2}$ ins., 11 stone 8 lb.) had run "100" in $9\frac{2}{3}$ secs. without getting it passed as a record, and N. J. Cartmell (twenty-four years, 5 ft. $11\frac{1}{2}$ ins., 11 stone 10 lb.), had done his "100" in $9\frac{1}{3}$ secs. and 220 yards in $21\frac{1}{3}$ secs.

Walker, in speaking of the Olympic 100 metres, which he won in $10\frac{1}{3}$ secs., has often told me that when Rector showed ahead of him at the half distance in the second round, he suddenly realized that he was not fast enough away at the pistol and so spent his time *on the morning of the final* practising starts. Kerr, who was twenty-six years of age, 5 ft. $7\frac{1}{2}$ ins. and 10 stone 10 lb., was a beautifully proportioned, well balanced runner and, like Walker, a tremendous starter, and this asset undoubtedly enabled him to take the Olympic 200 metres in $22\frac{2}{3}$ secs.

One of the best and perhaps the most unlucky of our early furlong men was L. F. ("Jimmy") Tremeer, L.A.C. He commenced sprinting in 1896, and by the next year was giving the English 100 yards champion a yard and a beating from scratch. In the A.A.A. Championships he was unfortunate in getting second three times in succession in the furlong, which he should have won at Northampton in 1903, but burst a shoe entering the home straight; a fortnight later, in a special race, he romped home in front of the champion, R. W. Wadsley, Unity A.C., in $22\frac{2}{3}$ secs.

From the days of Morton and George our sprint titles went abroad, until little Willie Applegarth, Polytechnic A.C., appeared in 1912. He stood somewhere about $5\frac{1}{2}$ ft., weighed not more than 9 stone, and owed most of his success to the coaching he received from the late S. A. Mussabini. It was for Applegarth that "Sam" invented the cross-arm swing and the curious shooting out of the legs from the hips with a thrust

of the pelvis, which actions have become peculiarly characteristic of British sprinters of small stature, and are shown on No. 1, Plate 6. Applegarth, like Walker, seceded from the ranks of amateurism, but before he turned professional he won five English titles, equalled world's record of 220 yards in $21\frac{1}{2}$ secs., and made the still unbroken British records of 150 yards in $14\frac{3}{8}$ secs. and 200 yards in $19\frac{3}{8}$ secs., and yet he was not good enough to beat the best of the Americans at the Stockholm Olympiad, 1912, R. C. Craig, U.S.A., winning the 100 metres in $10\frac{3}{8}$ secs. (after D. Lippincott, U.S.A., had done $10\frac{3}{8}$ secs. in his heat) and the 200 metres in $21\frac{7}{16}$ secs.

At Antwerp we were equally unlucky, for W. A. Hill, Surrey A.C., dual English Champion, 1919, left his running behind in Yorkshire, where he had run some amazing trials, while H. F. V. Edward, Polytechnic A.C. (No. 2, Plate 6), another product of Sam Mussabini, who had won the A.A.A. 100 yards in 10 secs. and 220 yards in $21\frac{3}{8}$ secs., was left on his mark in the 100 metres final, owing to the misunderstanding of an order given by a marksman, and in the semi-final of the 200 metres pulled a muscle in the back of his thigh. That this big coloured boy from the West Indies might have achieved an Olympic double is obvious. He finished third in both races, but lost three yards at the start of the 100 and ran very lame in the 200 metres.

This Olympiad introduced us to the greatest sprinter the world has yet seen. I refer to Charles Paddock of America, whose world's records read: 100 yards, $9\frac{3}{8}$ secs.; 220 yards, $20\frac{1}{8}$ secs.; 100 metres, $10\frac{3}{8}$ secs.; 200 metres, $20\frac{3}{8}$ secs.; 300 metres, $33\frac{1}{8}$ secs. Paddock (No. 4, Plate 5) is a short, thick-set individual, deep barrelled and having tremendous thigh and loin power. The mechanical precision of his high knee pick-up and long leg shoot action is perfection, but the "jump" finish with which he breasts the tape would not suit one man in a million.

Space will permit of my mentioning but a few other individuals. One of them must certainly be H. M. Abrahams, C.U.A.C. (No. 3, Plate 6). He made his *début* as an athlete by winning the L.A.C. "Sons and brothers of members" 150



1918

THE SPRINTS.

Pl. 5

1. "On the mark" position (W. R. Applegarth). 2. "Get set" position (W. R. Applegarth). Note short foot spread. 3. "Get set" long foot spread position, favoured by tall sprinters. 4. Second or third stride. C. Paddock, U.S.A., coaching in aspirant to Olympic honours. Note direct traction of arms and legs. 5. First stride-out of holes; start of Achilles v. Waseda sprint, 1928.



Pl. 6)

Sport and General [L 19

THE SPRINTS.

1. W. R. Applegarth showing the "Mussabini" cross arm swing sprint action, which lengthens the stride. Note shoulder shrug. 2. H. F. V. Edward, showing fine finishing form. 3. H. M. Abrahams, showing throw finish. 4. A bundle of finishing faults

The Sprints—100 to 300 Yards 49

yards Lotinga Challenge Cup from the 31 $\frac{1}{2}$ yards mark at the age of ten and a half in 1910, and repeated his victory in the following year from the 17 $\frac{1}{2}$ yards mark. In 1918 he represented Repton at the Public Schools Championships and won the 100 yards in 11 secs. At Cambridge he won the 100 yards four times against Oxford, doing 10 secs. twice, and also the A.A.A. 100 yards in 9 $\frac{9}{10}$ secs. in 1924. That year, realizing that his style, and especially his finishing needed improvement, he spent many months training under Mussabini, who invented a special dip finish for him, and at Paris he took the Olympic 100 metres, returning 10 $\frac{3}{8}$ secs. to equal Olympic record in the second round, semi-final, and final.

For the 1928 Games, America had still Paddock and in addition Chester Bowman, credited with 9 $\frac{3}{8}$ secs. for 100 metres, and Roland Locke, said to have won a furlong in 20 $\frac{3}{8}$ secs. Our hope was that J. E. London and W. Rangeley would rise to the occasion. South Africa had a second Reggie Walker in W. B. Legg, who won the A.A.A. "100" in 9 $\frac{9}{10}$ secs., and Germany possessed some amazing "flyers." But only a few people had ever heard of the nineteen-years-old Canadian schoolboy, Percy Williams, who was to make history by winning the 100 metres in 10 $\frac{3}{8}$ secs. from J. E. London, and the 200 metres in 21 $\frac{1}{8}$ secs. from W. Rangeley. Frank Wykoff, an American schoolboy, and the Germans, Corts, Houben, Körnig, and Wichmann, and Legg, the South African, all much fancied, seemed to lose their form.

We come now to the technique and training, whereby the great champions who have been mentioned have gained their victories.

The Crouch Start, to which reference has already been made, provides the best position of readiness and the quickest method of starting so far discovered. It comprises two positions: the first which is assumed when the starter gives the caution "Get to your marks," and the second when he orders the athlete to "Get Set." The following simple diagram (Fig. 1), studied in conjunction with No. 1, Plate 5, should make the "On the Mark" position quite plain to the reader.

Athletics of To-day

The starting position shown is that normally adopted by sprinters. It will be seen that the front foot is some six to eight inches in rear of the starting line and that there is approximately twenty-four inches between the starting holes occupied by the feet (E and H, Fig. 1).

Some sprinters, however, prefer the "Bullet" start, which is said to be faster, in which case the front foot (E) is moved back eighteen inches from the scratch line and the rear foot (H), although not altering its position, is only twelve inches behind the front foot. The chief advantage of the "Bullet" start is that it enables the athlete to drive off from both feet.

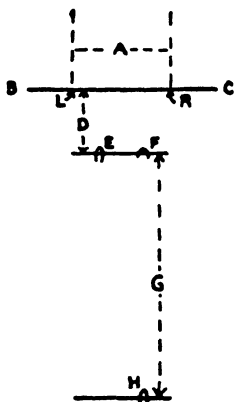

FIG. 1. BC—Scratch Line.
R & L—Position of Index Fingers.
A—6 inches more than breadth of shoulders. D—6 inches to 8 inches. E—Position of front foot, 6 inches to 8 inches behind scratch line. F—Position of knee of rear leg, level with ankle bone of front foot. G—Length of rear leg from knee to ball of rear foot.
H—Position of rear foot.

Nos 2 and 3, Plate 5, show two "Get Set" positions. Note the eyes looking forward along the track, the back practically parallel with the ground, disposition of the fingers, which, with the front foot, support the weight of the body, both knees directly in "line-ahead," and rear knee raised about eight inches from the surface of the cinders. When the starter gives the order "Get Set" the athlete must be careful to let his weight go forward on to his fingers and to press the front-knee well down before he raises the

rear knee from the ground. Sprinters must always remember that attention to the smallest details is of the greatest importance. Applegarth and many other fine sprinters used the hand position shown in No. 2, Plate 5, but Paddock and the more modern school prefer the "tripod spread," with the thumbs further back as shown in Fig. 2 and No. 3, Plate 5.

This position is said to give a man powerful support, while the advanced position of the fingers decreases the tendency of the runner to fall forward as he waits for the pistol. Right up to the moment the pistol cracks every part of the body must be

The Sprints—100 to 300 Yards 51

loose and relaxed. Take care about digging the starting holes. They should be deep enough to give a purchase to all the spikes in the soles of the shoes. The back wall of the front starting hole may slope back a little, but the back wall of the rear hole should be perpendicular, otherwise the rear foot will have to go back to get its drive-out impetus and time will be lost thereby. The advantage of the "Crouch" position is that it enables one to get an explosive start and to run rising gradually to the correct sprint angle through a distance of twenty-five to thirty yards. Have due regard in covering this initial distance for the body passing through a definite cycle of angles.

The sprinter is recommended to make out an angle chart as shown in Fig. 3, on tracing linen, and to have photographs



FIG. 2

taken frequently of himself from the side at the various stages of the race, so that he may lay the transparent angle chart over the prints and thus check his body angles. Learn to go forward, not up (See Nos. 4 and 5, Plate 5, and No. 1, Plate 7). If you find yourself getting up too quickly, reconsider your starting position; the trouble may be due to the front foot being too close to the line, or the feet being too close together, or you may be throwing your head back.

No. 5, Plate 5, shows the start of the 100 yards race, Achilles Club *versus* Waseda University Match, 1928. All the runners show excellent style in the first stride out of the holes, although J. W. J. Rinkel (26) is getting up too soon. Chuhei Nambu, between Rinkel and A. E. Porritt, shows the best forward body lean, and Shigenori Ohsawa (7) the better foot traction, leg drive and knee pick-up. The absolutely correct style in

taking the first stride out of the holes is shown in No. 1, Plate 7, H. Körnig, of Germany.

After the start there are two permissible styles for the athlete to adopt. He may either adopt the English method, invented by Mussabini and shown in No. 1, Plate 6, or he may adopt the American form as seen in No. 4, Plate 7. The Mussabini, or new English action, is based on the conception and practice of a man making the fullest use of his shoulders to "shrug" himself along. The action can best be learned by

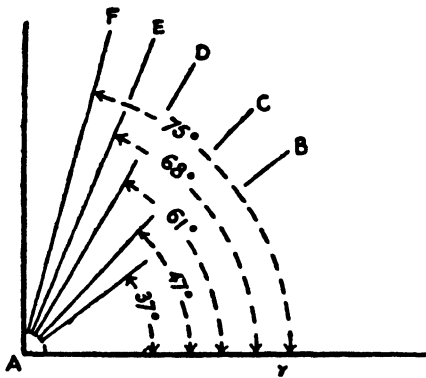

FIG. 3.

A B represents body at an angle of approximately 37° in first stride out of holes. A C represents body at an angle of approximately 47° in second stride out of holes. A D represents body at an angle of approximately 61° in third and fifth stride out of holes. A E represents body at an angle of approximately 68° in finishing final 25 to 30 yards of race. A F represents body at an angle of approximately 75° , which is the perfect sprinting angle for the distance between the initial 30 yards and the final 25 yards of 100 yards race.

holding a short length of wood in the hands, which are turned with the palms towards the body (see Fig. 4). The arms swing *across* the pit of the stomach, and the abdominal muscles rapidly accustom themselves to assisting the pull and thrust of the arms. The loose swing is greatly aided by the "shrug" or hitching up of the shoulders, there being a lift as the arms swing left and a lift as the arms swing right. This shrug is well shown by Applegarth in No. 1, Plate 6. The combined movements of the upper body help to lift the legs and lighten the effort. In this style the feet skim close to the ground and land very lightly well up on the toes.

When practising with the stick in your hands (see Fig. 4) try running ten to twenty yards as fast as you can with the shortest possible steps. Then ease the pace and open out your striding for twenty yards; alternate in this way from 100 to 200 yards. The easy action of a "Mussabini sprinter" is seen also in No. 2, Plate 6, H. F. V. Edwards, and No. 3,

The Sprints—100 to 300 Yards 53

Plate 6, H. M. Abrahams. Edwards (No. 2), approaching the end of a tremendous 220 yards, is a picture of the absolute poetry of motion, combined with presentation of perfect form.

The other, or American type of sprinting is that shown in No. 4, Plate 7, of C. W. Paddock (all in white). It is rather like the exaggerated fore-leg knee action of a champion trotting horse.

In the first stride both types of sprinter cover from $2\frac{1}{2}$ to 3 yards and take short rapid strides for the first 10 yards, after which the stride is lengthened out. The Americans raise the knees straight forward with a good lift and allow the lower leg and foot to swing through naturally (see No. 4, Plate 7), the foot coming down at the full length of the stride. The arms swing obliquely upwards and forwards, each hand coming in turn with a sort of upper-cut punch to a point in front of the opposite shoulder, or the middle of the chest. The hands are not checked at the hips, as in the English style, but swing back the whole way. In both styles the body is carried leaning forward about four inches in front of the line of the hips.



FIG. 4.

The crucial test comes in 100 yards somewhere between the 65 and 75 yards marks. It is there most men take the second breath, and, as one breath is expelled and another inhaled, the feet must be made to beat harder against the ground or the speed will decrease. The way to learn proper sprint-breathing is to go 50 yards at top speed, drop to quarter mile form and breathe for 20 yards, and then finish out the last 30 yards at top speed. The furlong runners should try to go 75 yards all out on one breath, relax the speed and breathe for 30 yards, and then sprint for the rest of the furlong.

From the breathing mark in an actual race the thing to do is to pitch the body forward to the finishing angle (A.E., Fig. 3),

get right up on to the toes and cut loose for the tape with every ounce there is left in you.

Finishing provides a problem. Paddock jumps for the tape, but his method is not recommended. Abrahams in No. 3, Plate 6, shows a shoulder lunge, which is very efficacious, but he changed it to Mussabini's "drop finish" before he won an Olympic title. In the drop method the runner drops his breast to the tape, but does not let his hips come back. (See No. 3, Plate 8, O. Andersson, Norway.) No. 4, Plate 6, shows almost every finishing fault it is possible to imagine. The foot is grounded flat, knee and toes turned out, hips going back, arms out of balance, and head thrown back. Never throw up the arms as you breast the tape. Good sprinters simply do not do it.

TRAINING

Be prepared to take a month or six weeks to reach top form. Start with strengthening the body muscles and in generally building up good physical condition. Reduce your work as your fitness grows and the number of your competitions increases. Each day's work should start with two or three jog-trots up and down the cinder path to loosen the muscles and warm you up, and should include five minutes' body-building exercises. A good week's work in mid-training period, which is, however, no more than suggestive of the individual training schedule, would be :

Monday.—Limber up, six starts, run 100 yards "breathing," five minutes body-building exercises, rest, sprint 75 yards, rest, practise finishing form, rest, jog an easy quarter mile.

Tuesday.—Limber up, jog an easy quarter mile, interpose quick break-away for a few yards, six starts with the pistol, five minutes body-building exercises, sprint 75 yards, practise two 100 yards, swinging round the bend of the track, jog 250 yards.

Wednesday.—Rest.

The Sprints—100 to 300 Yards 55

Thursday.—Limber up, four starts with pistol, one 50 yards and one 75 yards sprint, five minutes body-building exercises, jog quarter mile.

Friday.—Rest.

Saturday.—Time trial or competition. Beforehand, limber up with jog, followed by two 25 yard dashes, two or three easy starts. If no race, go on after trial to start of 220 yards and run 120 yards round curve. Run 220 yards at nearly top speed. Do body-building exercises either in morning or evening this day.

NOTE.—There must be at least a five minutes rest period between the practice of each item in the daily schedule.

CHAPTER III

THE EVENT *Sui Generis*—440 YARDS

THE first generation of British athletes to enjoy chances of championship competition gave the technical title of sprinting to the running of such short distances as a man might cover at top speed in one continuous sprint. They considered the limit of sprinting distance to be 300 yards, and regarded the quarter mile as something *sui generis* and distinct from sprinting.

The first two English championships at a quarter mile were won by J. H. Ridley, a remarkable schoolboy from Eton, who returned 52 $\frac{3}{4}$ secs. for his title in 1867. In the following year he went up to Jesus College, Cambridge, and won the Oxford and Cambridge quarter in 51 secs., a time which was bettered a few weeks later by E. J. Colbeck of the L.A.C., who won the English Championship in 50 $\frac{3}{8}$ secs.

Colbeck was a very tall and heavily built fellow. He ran with chest up and head back, but was not quite in the first class of sprinters, as was proved in his races at shorter distances with A. J. Baker, L.A.C., who won the 100 yards title in 1870. Colbeck owed his success mainly to his tremendous stride and his great strength. He is one of the great figures of athletic history, whose exploits should be known to the younger generation. On the afternoon of the English Championships at the old Beaufort House ground in 1868, Colbeck ran a brilliant 100 yards against the winner, W. M. Tennent, put up a new record of 2 mins. 2 secs. for the half-mile, and also ran an epic quarter mile. In the latter race he led all the way from start to finish, but cannoned into a sheep which had strayed on to the track, broke the animal's leg, and yet finished first in

The Event *Sui Generis*—440 Yards 57

50½ secs., a record which remained unbroken for thirteen years. Colbeck went to an early grave, but his records were remembered long after those of all his contemporaries had been surpassed and forgotten.

Colbeck first pointed the lesson of sprint quarter-miling to athletes, which was to be emphasized in no uncertain manner by L. E. Myers, who came over from America to win the A.A.A. quarter mile title in 48½ secs. at Aston in 1881. I do not know that Myers's athletic merit can be compared with that of such modern marvels as H. M. Osborn, U.S.A., and J. Yrjöla, Finland, whose all-round achievements in the Olympic Decathlon have amazed the world, but I fancy that Myers, on his actual records, will go down in history as the greatest short distance runner of all time, as he was certainly the most prominent performer in the early days of organised athletics in America.

Born at Richmond, Va., U.S.A., on February 16th, 1858, Myers was famous among his boy friends as a runner and jumper, but did not appear in competition until November, 1878, when he was twenty years of age. He won easily the quarter mile handicap of the New York A.C., upon that occasion, and in the following year carried all before him, winning the 220, 440 and 880 yards National Championships. He was then indulging in such an orgy of race winning that friends warned him that he was "running to an early death." His reply was an amused grin, accompanied by the startling statement that he was out to break every American record from 100 yards to 1 mile. This he proceeded to do. In 1880 he ran seven times in one afternoon and won the American 100, 220, 440, and 880 yards titles, and a week later at Montreal took exactly the same events in the Canadian Championships, thus establishing the still uneclipsed record of winning eight national championships in a week.

People in England simply would not believe that the young American could have accomplished all the feats and times with which he was credited. In 1881, therefore, his club, the old Manhattan A.C. of New York, sent him to England to prove his

prowess to our unbelievers. In England he acclimatised far more quickly than do most Americans and won his first quarter mile over here by eleven yards in $49\frac{1}{2}$ secs., beating all British records. At the English Championships a fortnight later at the Aston Track that unlucky Englishman, W. P. Phillips, made him do $48\frac{3}{4}$ secs. for a three yards victory in the quarter mile. Before going home he cut down twenty-two competitors in a half mile race and established a world's record of 1 min. 56 secs., which remained unbroken until he covered the distance in 1 min. $55\frac{1}{2}$ secs. at Birmingham in 1884. He made two other visits to England, in 1884 and 1885, defeating all our best runners, and in 1886, in America, overcame the great W. G. George at half, three-quarter, and one mile. From 1879 to 1885, when he turned professional, Myers won an American Amateur Championship each year and in some years held several. He made twenty-two amateur records from 50 yards in $5\frac{1}{2}$ secs. to 1 mile in 4 mins. $27\frac{3}{4}$ secs., including hurdle races at 220 and 440 yards.

Myers's mother died early of consumption, and he himself never carried an ounce of superfluous fat. His height was 5 ft. 8 ins. and his weight a trifle under 8 stone. He was, in appearance, a light running machine made up of phenomenally long legs attached to a disproportionately short body, and the more tired he became the more his long strides lengthened out. It was his custom, when heavier men in the middle of a race were taking a "breather," to shoot away and open up a gap of half a dozen yards. At his best he could probably have beaten 48 secs. for a quarter mile. He died in New York on the eve of his forty-first birthday in 1899, from a relapse following an attack of pneumonia.

Myers was followed by a succession of great athletes who had appreciated the lesson he taught. On a straight-away course at Beacon Park, near Boston, in 1886, Wendell Baker, the famous Harvard quarter miler, returned $47\frac{3}{4}$ secs., Maxey Long, New York A.C., subsequently reducing the straight-away record to 47 secs. flat at Guttenberg, N.J., in 1900, Baker

The Event *Sui Generis*—440 Yards 59

remarking after the race that on that track Myers would probably have touched $45\frac{1}{2}$ secs.

In England, in 1889, H. C. L. Tindall, C.U.A.C., set up the still unbroken English Championship record of $48\frac{1}{2}$ secs., and the only two runners who have beaten 49 secs. at the A.A.A. Championships since his day are Wyndham Halswelle, Edinburgh Harriers, 1906, and D. G. A. Lowe, C.U.A.C., 1927, both returning $48\frac{1}{2}$ secs.

The best American championship time of $48\frac{3}{8}$ secs. was made by W. E. Stevenson, the Oxford Blue, in 1921 and equalled by Kenneth Kennedy in 1926. Faster times have, however, been recorded in the American Inter-Collegiate championships. In 1912 C. D. Reidpath, Syracuse, who put up a new Olympic 400 metres record of $48\frac{1}{2}$ secs. at Stockholm, reduced the 440 yards record to 48 secs. This was equalled in 1914 by J. E. Meredith, Pennsylvania, the same runner returning $47\frac{3}{8}$ secs. in 1916. In 1918 F. J. Shea, Holy Cross, did $47\frac{3}{8}$ secs., and in 1925 J. P. Tierney, of the same University, covered the distance in $47\frac{9}{16}$ secs. The Oxford and Cambridge Sports record of $49\frac{3}{8}$ secs. was made by D. Macmillan, Trinity, Cambridge, in 1912, but B. D. G. Rudd, Trinity, Oxford, set the Iffley Road track record at $48\frac{3}{8}$ secs. just after the War, and C. J. B. Money Penny, Jesus, Cambridge, the Fenner's record at $49\frac{1}{2}$ secs. in the early nineties.

Despite the now accepted theory that the quarter mile is definitely a sprint rather than a middle distance event, the fact remains that, with few exceptions, the world's greatest quarter milers have been better men, alternatively, at the half mile than at 100 yards. Among the exceptions I would place D. Macmillan, with 100 yards in 10 secs. and 440 yards in $49\frac{3}{8}$ secs.; G. M. Butler (No. 4, Plate 8), with 220 yards in $21\frac{9}{16}$ secs., 300 yards World's Record in $30\frac{3}{8}$ secs., and 440 yards in $49\frac{3}{8}$ secs.; and Eric Liddell, with 100 yards in $9\frac{9}{16}$ secs., 220 yards in $21\frac{3}{8}$ secs., 440 yards in $49\frac{1}{2}$ secs., and the Olympic record of 400 metres (437.45 yards) in $47\frac{3}{8}$ secs.

Myers was a phenomenon for whom one cannot legislate; of the others, Colbeck, Bredin, Tindall, and Fitzherbert were all of

the longer distance quarter-miling type, who would probably have found their highest form at 600 yards, as indeed has D. G. A. Lowe, who was beaten by the German, Dr. Otto Peltzer, in the world's half mile record time of 1 min. 51 $\frac{3}{8}$ secs. in 1926, after having himself a week previously made a new world's record mark of 600 yards in 1 min. 10 $\frac{3}{8}$ secs.

But the best example of all is, perhaps, J. E. Meredith. Born at Chester Heights, Pa., U.S.A., on November 14th, 1892, he made his first appearance in athletics in 1904. His height was 5 ft. 9 ins., and at that time he tipped the scales at 10 stone 5 lb., but weighed 11 stone 4 lb. when at the age of 20 he came to the Olympic Games at Stockholm, 1912, and startled the world by his amazing running. At that period he had not won even an American junior championship, and at the time of the previous Olympiad had not yet entered college. His great achievements when representing Mercersberg Academy in the Scholastic Games gained for him, however, a place in the U.S.A. team, and he toed the line with the world's greatest half milers when the final of the 1912 Olympic 800 metres was called on. In that race—and a blanket finish—he beat Melvin Sheppard, record breaker at 800 and 1,500 metres in London, 1908; I. N. Davenport, U.S.A.; and H. Braun, Germany, who had taken the English title in 1 min. 58 $\frac{1}{2}$ secs.

There were many at Stockholm who thought that the old hands would out-general the youngster in the final, but those of us who had watched his running in the trials were less certain. Anyway, Ted Meredith not only won, but set a new Olympic 800 metres mark at 1 min. 51 $\frac{9}{16}$ secs., and continuing on created a new world's half mile record of 1 min. 52 $\frac{1}{2}$ secs. This surely would have been glory enough for any youngster of his age, but two days later in a trial heat of 400 metres he broke the Olympic record for that distance as well. In the final, however, C. D. Reidpath, who had recently set up a new collegiate record in America, Hannes Braun, and E. F. I. Lindberg (winner of the A.A.U. championship 1912, 49 secs.), all finished ahead of him.

May, 1916, found Meredith, then 24 years of age, at the

The Event *Sui Generis*—440 Yards 61

zenith of his fame. In that month he established the present world's record of $47\frac{3}{4}$ secs. for 440 yards, and the previous 880 yards record of 1 min. $52\frac{1}{2}$ secs., now broken by Peltzer and Lloyd Hahn. In the A.A.U. championships of 1915, incidentally, Meredith returned 47 secs. dead for the quarter mile, but the record was disallowed on account of the high wind. I remember seeing him run again in one of the American relay teams at Antwerp in 1920, but at 28 years of age he was past his prime.

Of Eric Liddell's great record breaking 400 metres race at Paris in 1924 all too little has been heard, for this unassuming Scot neither wrote about his own achievements in the Press nor encouraged other people to boom him. Nevertheless, Liddell's brief, meteoric athletic career was as brilliant as that of any runner the world has yet produced. From 1921 to 1925 he held the Scottish 100 and 220 yards titles, besides winning his national quarter in 1924 and 1925. In 1923 he came South and won the A.A.A. 100 yards in the still unequalled championship time of $91\frac{7}{8}$ secs., and the 220 yards in $21\frac{3}{4}$ secs., and in the following year took the 440 yards in $49\frac{3}{4}$ secs. At Paris a month later he would not compete in the 100 metres, since the heats were run on a Sunday; in the 200 metres he finished third. It was to represent Great Britain in the 400 metres, however, that he joined our Olympic team, and surely no man ever served his country better. I would go so far, in fact, as to say that Liddell's amazing victory was the outstanding feature of the Games. His first love in sport was, without doubt, Rugby football, at which game he was "capped" for Scotland eight times in 1922 and 1923, and it must have required a good deal of determination upon his part to forgo the Rugby season of 1923-24 in order to prepare himself for the Games. As a runner he was almost entirely without style, and his action was perhaps the worst displayed by any first class athlete since the days of Colbeck; but he was always lion-hearted, tremendously determined, and blessed with a most amazing turn of speed.

The happenings in the 400 metres at Paris will not be soon

forgotten by those of us who were fortunate enough to witness that series of thrilling contests which culminated in the supreme achievements of Eric Liddell, of Edinburgh University, and Guy Butler, C.U.A.C. The day before the race Liddell sat with me for a long time watching the progress of events in the stadium, and I recollect that he was much more concerned with the fact that Butler was having trouble with his leg than with his own chances upon the morrow.

A series of unprecedented happenings followed upon the next day. World's and Olympic record of $48\frac{1}{2}$ secs. had been made by C. D. Reidpath, U.S.A., at Stockholm in 1912. In the first five heats of the second round at Paris, only one winner failed to equal 49 secs. ; in the sixth heat J. Imbach, Switzerland, broke all existing records by returning 48 secs. ; and people began to wonder if Liddell, Butler, or any of the brilliant Americans could beat the swarthy little man from the Swiss mountains. The semi-finals resolved all doubts. Butler, favouring a "game" leg, was forced to start standing. He fought out a great race with H. M. Fitch, U.S.A., who further decreased the record to $47\frac{1}{2}$ secs., the Englishman being content to qualify in second place. Then Liddell beat Imbach handsomely in $48\frac{2}{3}$ secs.

When the men went to their marks for the final at 6.30 in the evening you could have heard a pin drop. Liddell, in the outside station, and Butler, next but one to the pole, started well. The little Scot, setting a pace which it seemed no man might hold, showed clear of the field at the top of the straight. The question was—would he crack? Suddenly his chin went up, his knees rose higher at every stride, all running science was thrown to the winds. It was incredible, but he was running faster than ever, and in the end he fairly ripped through the tape in $47\frac{1}{3}$ secs. for yet another new world's record.

It has been my luck to see most of the modern records made, from Melvin Sheppard's 880 yards in London, 1908, Nurmi's mile in Stockholm in 1923, Robert Legendre's $25\frac{1}{2}$ ft. long jump in Paris, 1924, and Otto Peltzer's half mile in London, 1926, right down to John Kuck's 52 ft. $0\frac{1}{4}$ ins. shot put at

The Event *Sui Generis*—440 Yards 63

Amsterdam in 1928 ; but I think that Liddell's 400 metres record at Colombes on July 12th, 1924, has stuck in my memory as perhaps the greatest athletic performance I have yet witnessed. He appeared to be running inside evens over the first 100 yards, and yet increased his pace for the last 100 yards.

Liddell (who is seen winning one of his great races in No. 3, Plate 7) is a living vindication of the doctrines of that great Irish-American coach, the late Michael Murphy, who, despite the records made by Ted Meredith, banked upon the running of M. W. Long, who could cover either 100 yards or a furlong in "evens," and who on October 4th, 1900, ran a straight-away 440 yards in 47 secs. dead. Upon the running of Long and Reidpath, Murphy based his opinion that quarter mile records are more likely to be made by the sprinter type of athlete than by men who combine the quarter and half mile as their distances. His opinion was further influenced by the fact that the ability of a sprinter to start quickly gives him the greater advantage of securing the pole position at once from the slower starting half-miler who essays a quarter.

The steady improvement in quarter mile records is due, first, to the lessons taught so long ago by Colbeck and Myers ; secondly, to the clear understanding that quarter-milers are of two distinct types ; and, thirdly, to the building up of definite methods of running the race in the way best suited to the type to which the aspirant to honours belongs.

Nowadays the Sprinter Type of quarter-miler is taught to get away from the mark fast, so that he may secure the pole position at the first bend ; and to hold his speed for at least 100 yards, after which, unless he be an Eric Liddell and therefore capable of sticking the course at top speed from pistol flash to finishing tape, he settles down to a float and a long-swinging stride. This gait carries him through the back straight with as little effort as possible. At the 300 yards mark the pace is increased, and 90 yards from home he should get right up on his toes, shrug his shoulders well forward, and go all out to win.

The Half Mile Type of athlete is taught that in running a quarter mile he must make up in endurance what he lacks in

sprinting speed. He is taught to keep out of the first struggle for position, and to save his strength for the fight at the finish. In this he has the advantage of meeting fewer contenders in the second struggle than usually take part in the initial rush for position. The sprinter type gains three or four yards by winning the pole position. The other type of man, providing he can pull the race all the way after reaching the back straight, has every hope of making up for his lack of initial sprinting speed. This has been proved by the running and records of such men as Meredith, Rudd, Lowe, and Stallard.

From time to time Great Britain has produced some remarkable schoolboy quarter-milers. J. H. Ridley, while still at Eton, won the first English Championship, 1866, in 55 secs., while T. C. Eastley, Haileybury, took the first Public Schools title in exactly the same time in 1890. In 1891, however, B. C. Whitaker, Charterhouse, set the Public Schools Championship record at $52\frac{3}{4}$ secs. Since then the "C. H. Mason Challenge Cup" has been won in $52\frac{3}{4}$ secs. by L. Cornish, Merchant Taylors, 1898, W. Morris, Bury, 1914, F. W. Tchitcherine, Brighton, 1926, and J. Simpson, Oundle, 1928. But the old record was never surpassed until in 1927 D. Barrington-Hudson, Imperial Service College, ran the distance in 52 secs. flat. Picture No. 2, Plate 8, shows him finishing out his record-breaking effort.

In South Africa, of course, the climate is more favourable to short distance running than in England, but even so the performances of L. B. B. Betts, of the Jeppe High School, Johannesburg, who at eighteen years of age recorded 100 yards in $9\frac{1}{4}$ secs., 440 yards in $48\frac{3}{4}$ secs., and half a mile in 2 mins. $0\frac{1}{4}$ sec., repeating his 100 and 440 yards times upon several occasions, are marvellous. In 1924 he came to England for the A.A.A. Championships and went on to Paris for the Olympic Games, but he did not acclimatise well in Europe and failed to reproduce his home form.

To whichever of the two types of quarter-miler the aspirant to honours belongs he must become proficient in the art of starting, and for that purpose, and to increase his speed, he

The Event *Sui Generis*—440 Yards 65

should train a good deal with the sprinters. The preceding chapter, which deals with sprinting, will give him all the information and advice he needs for that part of his work and also as to finishing style. The quarter-miler's arm action is the same as that of English sprinters, but a good deal lower than that of American sprinters. Apart from the initial speed burst for pole position and the finishing sprint, the quarter-miler has not the same need for a rapid beat of the feet upon the ground. His foot should be placed down directly under the body to ensure a long and elastic stride, the arms must swing easily and freely and the body incline slightly forwards. The object is to keep close to the ground and so the very high pick-up knee action, referred to in the last chapter, is never used.

It is a good custom to get into the habit of covering the first furlong of a quarter mile in 25 secs. ; anything much faster over the first half of the race, will leave you dwindling away at the finish. Concentrate on building up as much speed as you can for the final sprint, which follows the "float."

It has been said that 300 yards is considered the maximum distance a man can sprint in one continuous burst. The quarter-miler, therefore, must find a means of apportioning his speed. The half-miler type of quarter-miler does it by holding an even pace throughout, until he gathers his energies for the best sprint home he can manage. The sprinter type of quarter-miler uses a different method. He goes all out for 75 or 100 yards in the hope of winning the inside berth at the bend of the track. As soon as he has got position, or covered his maximum sprint distance, he relaxes, by dropping his arms a little, and so adjusts his action that he runs lower on the ball of the foot than he would in the sprint action, and his stride lengthens out. He also begins to breathe regularly. On this action he floats through until 140 yards from the finish. Then he gets up on his toes again, sets legs and arms going to a livelier tune, pitches his body forward to the true finishing angle (Fig. 3, A. E., page 52), and lets himself go for the tape.

TRAINING.

Do not try to run a quarter mile race until you have been in training for a month or six weeks and leave your serious training until you have devoted a fortnight to getting into fair physical condition by long walks and easy jog-trot half and three-quarter mile runs. After this begin to practise sprinting 100 and 250 yards at just under top-speed. Do plenty of body-building and stretching exercises. Learn how to run round the curve of the track by dropping the inside arm and remember that the bend is never the place to attempt to pass a rival. Do not run a quarter mile trial or race more than one day a week.

A quarter-miler should be a sound judge of pace. Develop this sense with the aid of a time schedule and a friend holding a stop-watch, who should shout your times to you as you flash by him. The following is Mussabini's Time Schedule, which represents the average of running at the intermediate distances in a quarter mile:

	100 yards	200 yards	300 yards	440 yards
Average Performer	12 secs.	23 $\frac{1}{2}$ secs.	35 $\frac{3}{8}$ secs.	53 secs.
The 52 sec. man	11 $\frac{3}{4}$	23 $\frac{2}{8}$	35	52
The 51 sec. man	11 $\frac{1}{2}$	23	34 $\frac{1}{2}$	51
The 50 sec. man	11 $\frac{1}{4}$	22 $\frac{2}{8}$	34	50
The 49 sec. man	11	22	33 $\frac{2}{8}$	49
The 48 $\frac{1}{2}$ sec. man	10 $\frac{3}{4}$	21 $\frac{3}{8}$	32 $\frac{1}{8}$	48 $\frac{1}{2}$

Each day's work should start with five minutes body-building exercises and one easy jog-trot quarter, to warm up before stripping out.

As to schedules, one can offer only suggestions, since each individual must ascertain for himself what suits him best. The work may vary between the suggestions A and B, given hereunder, for a week's work when one is really fit:

championship in 2 mins. $16\frac{1}{2}$ secs. In 1890, H. L. Dadman, Manhattan A.C., became national champion in 1 min. $59\frac{1}{2}$ secs., and W. C. Dohm, Princeton, Inter-Collegiate title holder in 1 min. $57\frac{1}{2}$ secs. J. E. Meredith, of Pennsylvania, in 1916, set up the American national record of 1 min. $52\frac{1}{2}$ secs. and also, the Inter-Collegiate record of 1 min. 53 secs.

One imagines that the improvement that has taken, and is still taking, place in middle distance running is not due entirely to better tracks and a better appreciation of pace and the manner in which a race should be run. There must be better physical qualities about the athletes themselves, I fancy, for boys at school get little or no coaching, and they run on the same rough grass tracks as served the needs of their forefathers. For the sake of comparison it may be remarked that the first English title (1866) was acquired in 2 mins. 5 secs., that of America (1876) in 2 mins. 10 secs., whereas the first English Public Schools Championship (1890) was won by G. E. Barry, St. Paul's, in 2 mins. $6\frac{1}{2}$ secs., while in 1927, H. S. Townend, St. Edmund's, Canterbury (Picture No. 2, Plate 10), brought the Public Schools record down to 2 mins. $1\frac{3}{4}$ secs., and it will not be long before "even" time is beaten by a schoolboy. Since Townend went up to Oxford in 1928 he has shown remarkable promise and may, in my opinion, develop into one of the world's greatest middle-distance runners, with, perhaps, the best prospects at one mile.

Improvement has been accomplished by more intensive competition, better track surfaces, and better-fitting running shoes, but mainly through two other circumstances—first, the appreciation of the principle that the initial quarter mile lap should be run at least 3 secs. faster than the second and last lap; and, secondly, the taking up of half mile running by men who have more initial aptitude for a quarter mile than a mile.

It is, of course, true that Melvin Sheppard, U.S.A., who showed 1 min. $53\frac{3}{4}$ secs. for half a mile in the States and won the 1908 Olympic 800 metres in 1 min. $52\frac{1}{2}$ secs., won also the Olympic 1,500 metres (1,640 yards 15 ins.) in 4 mins. $2\frac{3}{4}$ secs., and that A. G. Hill, Great Britain, British record holder for

1 mile, run in 4 mins. $13\frac{1}{2}$ secs., took both the 1,500 metres (4 mins. $1\frac{1}{2}$ secs.) and the 800 metres (1 min. $53\frac{1}{2}$ secs.) at the Antwerp Olympiad, 1920. Nevertheless it is equally true that Ted Meredith, U.S.A., although beaten into third place in the Olympic 400 metres (437 yards 16 ins.) at Stockholm, 1912, won the 800 metres in 1 min. $51\frac{1}{10}$ secs., finishing out the half mile in 1 min. $52\frac{1}{2}$ secs. He still holds the world's 440 yards record of $47\frac{1}{2}$ secs., and until 1926 held also the half mile record of 1 min. $52\frac{1}{2}$ secs.

Then again the present official half mile record holder, Dr. O. Peltzer, Germany (Picture No. 2, Plate 9), holds also the 500 metres record, 1 min. $3\frac{1}{2}$ secs., while D. G. A. Lowe (Picture No. 3, Plate 10), Great Britain, who beat previous world's best when he was defeated by Peltzer in the A.A.A. Championship half mile of 1926, holds the world's 600 yards record of 1 min. $10\frac{1}{2}$ secs. (1926), and in 1927 and 1928 won both the 440 yards and 880 yards English Championship titles, and captured the Olympic 800 metres in 1924 and 1928.

There is also Lloyd Hahn, Boston A.A. (Picture No. 3, Plate 9), who in 1927, was the outstanding runner of the American indoor track season, his best performance being that in which he eclipsed Dr. Peltzer's 1,000 metres record by returning 2 mins. $26\frac{1}{2}$ secs. Early in 1928 he knocked a fifth of a second off Peltzer's half mile record, and later was credited with a new half mile record of 1 min. $51\frac{1}{2}$ secs. He ran at Paris in 1924 and finished sixth in the Olympic 1,500 metres; among those who beat him were the two Cambridge blues, H. B. Stallard and D. G. A. Lowe. At Amsterdam, 1928, when Lowe made a new Olympic record of 1 min. $51\frac{1}{2}$ secs. Hahn was fifth.

Half milers, therefore, are of two distinct types. The one class, men like A. G. Hill and Melvin Sheppard, who have strength for a mile and sufficient speed for a half mile; and the quarter-miler type, who have the great speed of the sprinter and just enough endurance to carry them through the longer 880 yards distance. On the whole I think that the latter class have the greater chance of breaking records, for with each year that passes the quarter mile partakes more of the nature of a sprint

from start to finish, while the half mile affords the runner but little space for letting up or easing his muscles by changing his method of striding. I suspect shrewdly that it was his long association with A. G. Hill that made that *doyen* of British athletic coaches, the late S. A. Mussabini, disagree with all other coaches when he said that a man who wanted to run a half mile in 2 mins. should aim at a first quarter in 63 secs., for, primarily, Hill was a mile runner before anything else.

There is one danger which the quarter-miler type encounters, and which has cost some runners dearly. It is the temptation to train at distances short of the full half mile, and to trust to the excitement of the actual race to carry them through to the tape in winning form. In 1926, D. G. A. Lowe was persuaded to train for an attempt upon the 600 yards world's record at Stamford Bridge on June 26th. He achieved his purpose and set up new figures, but when he came to race against Peltzer in the A.A.A. Half Mile Championship a week later it was obvious that although he could eclipse Ted Meredith's ten-year-old figures, he had not the stamina to stave off the German's challenge, when the latter raced past him to establish an even more sensational world's record.

Peltzer was, I think, lucky to beat Lowe in the A.A.A. Half Mile Championship of 1926, despite the time, 1 min. 51 $\frac{3}{4}$ secs., for the German made no sort of showing in distance races in the ninth Olympiad at Amsterdam, 1928. Apart from the fact that Lowe had committed the fatal error of training for that 600 yards attempt on record, the championship race was not run to suit him. Every Englishman who figured in the final was playing for his own hand, as they were entitled to do, and, in consequence, Lowe had to take the lead and cut out his own pace and, incidentally, Peltzer's, from start to finish. At Amsterdam it was far otherwise, for W. G. Tatham and R. S. Starr paved the way admirably for a great British victory.

At the Paris Olympiad, 1924, a man had to do something better than 1 min. 58 secs. to take a semi-final of the 800 metres, while Lowe himself was hard pushed in returning 1 min. 52 $\frac{3}{4}$ secs. in the final to beat P. Martin, Switzerland, and S. C.

Enck, U.S.A. ; Martin, indeed, ran Lowe to a terribly close finish (as can be seen from Picture 1, Plate 9). In fact, the Cambridge Blue only just managed to get up in the last ten yards.

In 1926 the young French champion, Seraphin Martin, represented France against England at Colombes, when he made the running too early through inexperience and was beaten by both Lowe and Tatham in 1 min. 52 $\frac{2}{3}$ secs. But in 1927, when the return match was held in London, he gave the English spectators some thrills of anxiety.

In this particular event, Lowe was supported by the young Oxonian, V. P. Brown, and A. R. Taylor. Their opponents were Sera Martin, R. Wiriath, and I. Keller. It was a curiously run race, and the slow first lap of 435 yards in 58 $\frac{1}{3}$ secs. did not at all suit Lowe, but he came suddenly to life when Martin raced by him with nearly 350 yards still to go. Entering the back straight, Lowe assumed the lead, but only for an instant, then Martin tore past him again and opened up a gap. To those who had not seen Lowe win the 1924 Olympic 800 metres from a position which had appeared equally hopeless it seemed certain that the Frenchman must win, but Lowe got to his shoulder with twenty yards yet to run, and then, just as he had beaten the Swiss Martin in Paris, so he beat the French Martin in London, but only by inches (as shown in Picture 1, Plate 10) and the time for the second quarter was 55 $\frac{2}{3}$ secs., or 3 secs. faster than the first lap, which is directly contrary to all the accepted tenets of the way a half mile race should be run. The effect is seen in the full time, 1 min. 54 $\frac{1}{2}$ secs., as compared with Lowe's 1924 Olympic victory of 1 min. 52 $\frac{2}{3}$ secs. and his 1928 time of a full second faster.

A week later at the French championships, Martin established two new French records by running 800 metres in 1 min. 52 $\frac{1}{3}$ secs. and 1,500 metres in 3 mins. 59 $\frac{2}{3}$ secs. It may be added that in the 1927 Franco-German match, Martin finished first in the 800 metres (1 min. 53 $\frac{1}{3}$ secs.), with the Germans Neumann second (1 min. 53 $\frac{2}{3}$ secs.) and Peltzer third (1 min. 54 $\frac{2}{3}$ secs.).

Douglas Lowe is both a great and a charming personality.

He made his *début* at the Public Schools Championships of 1920 and won the half mile in the moderate time of 2 mins. 6 $\frac{1}{4}$ secs. From Highgate School he went up to Pembroke College, Cambridge, and against Oxford won the Half Mile in 1923, 1924, and 1925, and the One Mile in 1924. He took a world's championship at the Olympic Games, 1924, before he had won an English title, but made up for that later by winning the A.A.A. 440 yards and Half Mile as a double event in 1927 and 1928. Had he run in both the 400 and 800 metres events at Amsterdam, and there was no reason why he should not have done so, I firmly believe that he would have won both, for he was in training for the two as was proved by his A.A.A. "double."

The winning of Lowe's record 800 metres Olympic title at Amsterdam in 1928 provides such a brilliant example of racing strategy and track tactics that I shall deal with the contest in detail. It must be remembered that among the entries were O. Peltzer, world's half mile record holder, and his very excellent fellow German, H. Englehardt, Lloyd Hahn, U.S.A., said to have beaten Peltzer's record, Sera Martin, France, E. Byhlen, Sweden, and P. Edwards, the Canadian negro, all just about reaching world's record breaking form. We knew that no representative of Great Britain, other than Lowe, would have a chance in the final and were well satisfied to find the other two Cambridge Blues, W. G. Tatham and R. S. Starr, coming through to the semi-finals with him. Lowe drew a fairly soft heat and qualified for the final behind Earl Fuller, U.S.A. Tatham, drawn in the hottest heat with Hahn, Edwards, and Martin, and Starr, up against Ray Watson, U.S.A., Byhlen, and Englehardt, both did admirable work by obeying orders and making the pace a "fizzer" from the start. In consequence, Lowe came home quietly behind Fuller in about 1 min. 57 secs., but Starr pushed his field along to make Byhlen do 1 min. 55 $\frac{3}{4}$ secs., and Hahn had to fight hard to master Edwards, Martin, and Tatham in 1 min. 52 $\frac{3}{4}$ secs. That heat seemed to puzzle Hahn, and the effort took a lot of the sting out of him, for he ran stale and with poor judgment in the final the next day.

Lowe came out for the final very quiet and collected. He waited until all the other competitors had drawn for positions and then picked the last number out of the hat, to find he had taken the favoured inside berth. E. Byhlen, Sweden, was next from the pole, and next him was H. Englehardt, Germany. At the crack of the pistol, Lowe jumped right into the lead, but the Canadian, P. Edwards, was close to his shoulder. Then Lloyd Hahn, who had run such a wise waiting race the day before, dashed into the lead to test his rivals, but no one would let him back once he was in front. Forced to act as pacemaker, he tried to build up such a speed as would break the field. But Lowe, Englehardt, and Sera Martin just made him run while refusing to take over. As the field came to the back straight for the second time, Lowe went up to Hahn's shoulder to test him. The American increased the pace for perhaps half a dozen strides, and then Lowe shot by, followed by Martin and Byhlen; Edwards and Hahn dropped back, and the other Americans and Keller, France, were out of the running. Lowe went on alone, changing his smooth stride to a deceiving gallop; Martin cracked and was passed by Edwards, leaving the Swede and the German to fight a supreme battle for second place, in which Byhlen came off best, with Hahn a poor fifth, and Lowe the victor by a dozen yards, in the new Olympic record time of 1 min. 51 $\frac{1}{2}$ secs.

It will be seen from Nos. 2 and 3, Plate 9, and 3, Plate 10, that the body carriage of the half-miler is more upright than that of the sprinters and that the major portion of the running is done on the ball of the foot; the eyes should be directed at a spot on the track about ten yards ahead. The stride, which is loose and free, may be lengthened by pushing off harder with the foot as it leaves the ground (see No. 2, Plate 9) and by endeavouring to put the foot down some four inches further forward than the normal length of stride; this reaching out action is helped by the throw of the knee and the pointing of the toes. An easy arm action, which comes from the natural swing of the hips, should not be interfered with. The arm, bent at the elbow, should swing forward as the back leg is straightened

880 yards in 1 min. 57 secs. In the whole history of the Oxford and Cambridge Sports, 4 mins. 20 secs. has been beaten only twice, *i.e.*, in 1894, when W. E. Lutyens, C.U.A.C., returned 4 mins. 19½ secs., and in 1908 when C. C. Henderson-Hamilton, O.U.A.C., made the present Inter-University record of 4 mins. 17½ secs. The first man to beat 4 mins. 20 secs. in an English Championship was the great W. G. George, Moseley A.C. who (No. 6, Plate 12), took the title of 1884 in 4 mins. 18½ secs.

In America 4 mins. 19½ secs. was returned by A. R. Kiviat (Irish-American A.C.) when he won the 1911 A.A.U. Championship. In 1925, however, the national record was reduced to 4 mins. 12 secs. by both Paavo Nurmi (Finland) and Joie Ray (U.S.A.). The first man to bring the American Inter-Collegiate record below 4 mins. 20 secs. was W. C. Paull (Pennsylvania), who in 1909 recorded 4 mins. 17½ secs., this record being still further reduced to 4 mins. 14½ secs. by J. Paul Jones, Cornell, in 1913.

The late seventies brought to light a tall, thin English runner, with a prodigious stride straight from the hips. This was W. G. George, born at the village of Calne, in Wiltshire, on September 9th, 1858. He was to become one of the most famous distance runners of all time in due course. In the heyday of his amateur career, George won twelve A.A.A. Championships at half, one, four, and ten miles, still a record for any individual. In those days his principal rivals were B. R. Wise, O.U.A.C., who afterwards became Attorney-General for New South Wales, and W. Snook, of Shrewsbury, a short, thick-set man of remarkable physique. By the end of 1884, George had fulfilled his ambition to beat all amateur and most world's records from 1,000 yards to 12 miles, the L.A.C. having arranged a series of special handicaps during that year for his benefit. There was only one man in the world who could claim equality with George. That was W. Cummings, but he was a professional, which precluded a meeting between the two.

For two reasons George determined to join the professional ranks. In the first place the A.A.A. would not grant him

permission to run against Cummings. In the second place, so wholeheartedly had he followed the pursuit of athletic honours that he had failed to complete his career as a student of chemistry and was in serious financial straits. His debts amounted to over £1,000 and his creditors were becoming importunate. George's difficulties and his desire to test himself against Cummings led to the arranging of a one mile match at Lillie Bridge in 1885. Arrangements were made for the accommodation of 10,000 spectators, but 30,000 people turned up to see the race and stormed the gates. George was forced to reach his dressing room at the top of the old grand stand by means of a ladder from an adjoining coal yard.

Cummings, who then held the world's mile record of 4 mins. 16½ secs., let George take the lead at the beginning of the race, but no sooner was the ex-amateur ahead than he felt something strike his heel as his foot came up behind. He was convinced that his opponent was trying to spike him and at once piled on the pace. This did not alter the position, and every fifty yards or so he felt that terrifying tap-tap on his heels. He knew that a spiking or a wrenched-off shoe would mean defeat, and he has himself said that he was urged on by the thought of the action his creditors would take should he lose that race.

With 1,000 yards covered, Cummings, running beautifully, drew level with his man. The sight of his opponent caused George to throw discretion to the winds. At the three-quarter mile mark he had established a lead, and a furlong from home a great shout from the spectators told him that something had happened. Suddenly he realised that Cummings was beaten, and, himself utterly exhausted, George almost stopped. Cummings, seeing this, started running again, but so did George, passing the tape an easy winner in 4 mins. 20½ secs. His first three lap times on that occasion were slightly faster than when he broke record in 1886, but the stop in the fourth lap spoiled the total time.

George saw Cummings after the race and warned him not to repeat his spiking tactics, whereupon his canny opponent grinned broadly.

In his heat Jackson ignored pace, stuck to schedule, and learned the important secret that if he could be within striking distance of the other finalists at the bell lap he had that wonderful finishing burst—perhaps greater than any other miler has ever possessed—to bring him home ahead of all the others.

Fourteen runners started in the final, and Jackson failed to secure the pole position. It has been said that he trailed the field, but that is not true; he tried to find a place in the moving file of runners, but he could not; and then Baker, "setting up an example of calculated and unselfish pace-making such as may never be equalled among classical foot-runners," left the living string and began to pilot the Oxonian round them. In this way Baker and Jackson must have run 50 yards further than the rest. And then, as the bell clanged for the last lap, the Americans bunched together, with Kiviat, their best hope, well covered in the inside berth. Baker dropped back, but Jackson stayed with the Americans on an outside station. Coming into the home stretch, he cut loose, and those great, raking strides carried him to an amazing victory in the new Olympic record time of 3 mins. 56 $\frac{1}{2}$ secs.

Prior to the making of the present British amateur record of 4 mins. 13 $\frac{1}{2}$ secs., A. G. Hill (Polytechnic A.C.) and his trainer, the late S. A. Mussabini, had decided that it would be possible for Hill to run a mile in 4 mins. 8 secs., provided he could stick to an even 62 secs. for each of four successive quarter miles. When the A.A.A. Championships were held in 1921, Hill drew second position from the inside of the track, with H. B. Stallard, C.U.A.C., one place from him and W. R. Seagrove, C.U.A.C., right away on the flank. Hill went straight into the lead, followed by Stallard, with Seagrove coming across at great speed to make the pace for his fellow Blue. Hill would not give up the lead, but was forced to run the first quarter in 59 $\frac{3}{4}$ secs. and the half mile in 2 mins. 4 secs. At the bell the time was 3 mins. 11 $\frac{1}{2}$ secs., and still Stallard was at Hill's shoulder. From that point the pace increased. A furlong from home Stallard challenged, but still Hill piled on the pace. Stallard challenged again entering the final straight, but the strength

was not there, and so Hill finished first past the post in 4 mins. 13 $\frac{3}{4}$ secs., Stallard returning 4 mins. 14 $\frac{1}{2}$ secs. The finish of the race is seen in Picture No. 3, Plate II. Hill had been forced to go inside his schedule in the first lap to retain the lead, but was back to the right figure at the half distance; a too fast first lap had, however, to be paid for, and that payment was made in the third lap, for which he took 67 $\frac{1}{2}$ secs.

Hill commenced his sporting career at fifteen years of age with the Gainsford A.C. as a swimmer and cyclist. The winning of second place in an 880 yards flat race, weaned him to athletics, and in 1910 he won the North of the Thames Cross-Country Championship from 300 opponents and in the same year won the A.A.A. four miles in 20 mins. 0 $\frac{3}{4}$ secs. Then came 1914 and his first bid for shorter distance honours. In the A.A.A. 880 yards Championship, Homer Baker, U.S.A., beat him by inches in 1 min. 54 $\frac{3}{4}$ secs. for a new championship record. The War years he spent in France with the R.A.F. From 1919 onwards it was evident that he was becoming a record-breaker. At Antwerp in 1920 he won both the 800 and 1,500 metres at the Olympic Games, and in 1921, after he had been running for eighteen years, he smashed Joe Binks's British one mile record. A. L. Treble, Polytechnic Harriers, might have developed into as good a middle-distance runner as Hill, but the War robbed him of his chance.

H. B. Stallard, C.U.A.C., was educated at Sherborne, where he won five events at the school sports, *i.e.*, 220, 440, 880 yards, 1 mile, and steeplechase, which rather bears out the contention that a great miler must be also a sound sprinter. He went to Cambridge in 1919, where his huge stride and dashing style soon created an impression. He tried cross-country running, but it was too much for him, and so he settled down to track work. In 1923 he won the A.A.A. Mile in 4 mins. 21 $\frac{3}{4}$ secs., and in 1924 the Half Mile, beating D. G. A. Lowe by $\frac{3}{4}$ yard in 1 min. 54 $\frac{3}{4}$ secs., and in 1925 took the 440 yards in 50 secs. In the Oxford and Cambridge Sports he won the Mile three times.

The first time I met Paavo Nurmi, of Finland (see No. 1, Plate II) was at the Antwerp Olympiad in 1920, and I think

that those of us who saw him win the 10,000 metres there at once realised that a new record-breaker had arrived. Shortly afterwards he turned his attention to the short middle distances, and in 1923 I was present at the Stockholm stadium on the historic Sunday when Paavo Nurmi, racing against Edvin Wide, a very fast Swede, set the world's record at a figure only dreamed of by previous generations. He was then twenty-five years of age, stood 5 ft. 10 ins., and weighed 10½ stone.

Nurmi, like Hill, had a 4 min. 8 secs. mile in mind, but, as had happened with Hill in 1921, the forcing tactics of the opposition obliged Nurmi to depart from his pre-arranged schedule. For the first lap Wide set the pace, and a study of the times given below proves that Nurmi never let him get away. At the half mile they were dead level, but from that point the Finn forged gradually ahead to achieve a new record of 4 mins. 10⅔ secs., but not the even faster time for which he had hoped. The race was run as follows :

	Wide	Nurmi		Wide	Nurmi
¼ mile	58 $\frac{5}{10}$	58 $\frac{6}{10}$	¾ mile	3.7 $\frac{3}{10}$	3.6 $\frac{7}{10}$
½ mile	2.1 $\frac{8}{10}$	2.1 $\frac{8}{10}$	1 mile	4.13 $\frac{1}{10}$	4.10 $\frac{4}{10}$

At the Paris Olympiad, 1924, Nurmi in four races overcame all opposition without really exerting himself, and I noticed that he carried a stop watch in his hand, timing himself over the intermediate stages of each race. Behind every mile that Nurmi has run in competition have been hundreds of unwatched miles travelled along lonely, ice-coated Finnish roads. For Paavo never had any delusions. He knew that the runner who would be great must punish himself to the limit, and he did it, and built up his great schedules with the aid of a cheap stop watch. The more Nurmi ran the further his individual limit receded, and so this superman was self-made. It would have been a lonesome, dreary business but for his peculiar mentality. He was a machinist at first, and later a draughtsman. He ran

five miles a day to work and a similar distance home again, and all this while he and his stop watch were evolving the method that was to revolutionise middle distance running. That cheap watch was his only opponent. He learned to run against time, and thus eliminated the human element. He has grown abnormally sensitive to pace, and it is useless for his opponents to try to jockey him.

Great American middle distance men, like John Paul Jones and "Chesty" Joie Ray, had set a fashion of running a mile with sensational first and final quarters and a rest period over the middle stages of the race. This practice was general, until Nurmi came along to run his epic races all in one stretch to an even time schedule. Those schedules are planned to allow the "Phantom Finn," as he is nicknamed, to run all the sprint out of his rivals in a race in which there are no "breathers," and no chance to store up finishing speed. It is in the third quarter mile, where others are accustomed to let the pace flag, that Nurmi beats them all; for that third lap he runs as fast as any other.

After he has got his form the matter of first moment to the miler is the making of his time schedule. For no great mile races are fortuitous nowadays, and, all else being equal, the man who can stick to a pre-arranged time schedule will win eight times out of ten. The first quarter mile is bound to be a bit faster than the others, except possibly the last, because of the initial sprint for position, but the late Sam Mussabini was I think the finest judge of a miler I have ever known, and it is his schedule that is given here for the guidance of the reader:

	$\frac{1}{4}$ mile	$\frac{1}{2}$ mile	$\frac{3}{4}$ mile	1 mile
	m. s.	m. s.	m. s.	m. s.
The 5 mins. man	0 68	2 25	3 42	5 0
The average useful miler	0 65	2 18	3 31	4 45
The 4 mins. 30 secs. man	0 62	2 10 $\frac{1}{2}$	3 20	4 30
The 4 mins. 25 secs. man	0 61	2 8	3 16	4 25
The 4 mins. 20 secs. man	0 60	2 6	3 12 $\frac{1}{2}$	4 20
The 4 mins. 16 secs. man	0 59	2 4	3 9 $\frac{1}{2}$	4 16

Before we think about form, therefore, we will consider this important question of schedule. Mussabini's figures are meant as a guide and represent no more than the average of running at the intermediate distances. Each runner may try to work to them, but must find the schedule that suits him best. There is the old adage that it is "the pace that kills and not the distance," which was put another way by a great American coach who used to be always telling his charges, "It isn't how far you run but how fast that matters." Judgment of pace, then, is the fundamental basis of successful miling, and that judgment can be acquired only by the constant use of the stop watch in training, with a friend to time you over the 220, 440, 660, 880, 1,320, 1,540 and 1,760 yards. The unusual checks at 220 and 1,540 yards are suggested to give you a guide to your starting and finishing speeds.

When once you have acquired the ability to assess your speed, learn what is your best pace and make use of that through the body of the race. Some men run an amazingly fast first 440 yards, and gradually lose on this through the next three-quarter mile. Others hold a sprint for forty or fifty yards to get a good pole position, preferably in the first three, without taking the lead. They then change quickly from the sprint to the normal distance stride and action and hang on to the man they have chosen as their pacemaker, provided his pace fits in with the preconceived time schedule.

Second wind, which is probably due to the action of the heart and lungs adjusting themselves to the demands made upon them, generally comes in the second quarter mile, but this varies a lot with the individual. The third quarter is always the most trying, because it provides the crisis of the race when all the runners are watching for the fellow who is "going to have a cut at it." If you look back to the table of great mile times on page 82 you will see how often the third quarter is the slowest of the four. If you can hold to your schedule over it your chances of winning will increase materially. Keep an even stride and pace, do not challenge unnecessarily, and do not take up every challenge that is offered. Read what

I have said in the preceding chapter on page 76 as to the way to avoid being shut in.

In the fourth lap hold to your schedule pace until you know you are near enough to the tape to risk a sprint, or until your opponents force you to make your effort. Do not forget you have to fight your own growing fatigue as well as your competitors. Do not let your head come back for that will bring your hands and knees up, and there will be a general tying up through the breathing being interfered with. The thing to aim at is to know how to distribute your own energy to the best advantage throughout the whole race.

The pictures which illustrate this and the preceding chapter are a good guide to the middle distance runner's style, and the remarks on the half-miler's action should be studied. The miler runs perhaps a trifle more erect and a little further back on the ball of the foot. His eyes are directed to a spot ten yards ahead of him on the track, and he must not run with a kick up of the heel behind. Observe Nurmi's long "hang" of the back heel in Nos. 1 and 2, Plate 11.

Paavo Nurmi, the great Finnish runner, who holds, among many world's records, those of 1,500 metres (1,640 yards, 1 ft.) in 3 mins. 52 $\frac{3}{8}$ secs., and 1 mile in 4 mins. 10 $\frac{3}{8}$ secs., has many points in style which are peculiarly his own. To begin with, he has a peculiarly high hand carriage combined with the twist of the upper arm backwards, which does not, however, alter the squareness of the shoulders. He runs every event with shoulders well back and head up, as if to give his heart, which beats slower than the average, and his unusually large lungs plenty of air; he has a long bounding stride, which shoots the foot well forward at the end of a leg only slightly flexed at the knee, and he never lets the heel rise above the height of the knee as the leg goes back just before the front foot is put down (see No. 1, Plate 11). His feet seem to pull rather than to push him along. Note the upright carriage of the body above slender hips and the unusual carriage of his arms. These points are well shown in the illustrations, and his action should be compared with that of Lloyd Hahn, who is following him in

No. 2, Plate II. As Nurmi's front foot is grounded at the completion of each stride he lets the knee of that leg give a little and leans his body forward so that the next stride may be perfectly balanced and aided by a strong push off. At the last Olympic Games in Amsterdam I noticed that all the new generation of Finnish middle distance runners—Kinnunen, Larva, Loukola, and Purje—have adopted Nurmi's peculiar form, and it is not improbable that this new style may soon be given something more than a merely national vogue.

Lightly built, natural runners of the Stallard type need very little work beyond an occasional half or three-quarter mile spin at moderate speed and a fair amount of walking—six or eight miles at a speed of four miles an hour.

The more robust type, like A. G. Hill, Lloyd Hahn, and C. Ellis, need long and strong work to start with, a good deal of sweating, and hard running up to two miles and walking up to ten miles.

Milers should do a good deal of sprinting and quarter-miling, aiming in the latter work at a 69 secs. quarter, reduced gradually to something faster. Let the miler read his own history on the track by studying his footwork and measuring his strides; let him find out the weight at which he does his best work and check it by constant use of the scales.

Acquire perfect control of your own body by varying the length of the stride while running in training.

One means of resting oneself during a distance race is to alter the gait, but this must be done without decreasing the speed of progression. Striding provides the normal gait, but a bounding action may be used for short periods without loss of speed. The difference between the two actions may be seen in Fig. 5. The triangles represent the approximate time during which the foot is on the ground forming the fulcrum upon which the body swings forward and the intermediate curves denote the distance covered by the effort. The effort put forth in striding is obviously the greater of the two, and striding, therefore, is more fatiguing but increases the speed, as will be apparent by

Athletics of To-day

reason of the three striding triangles taking the place of the four bounding triangles, although exactly the same

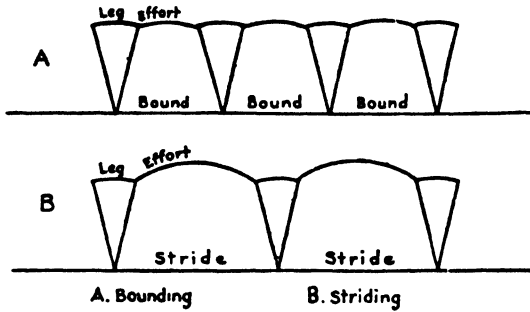

FIG. 5.

distance has been covered in each of the two cumulative efforts.

CHAPTER VI

THE DISTANCES—2 TO 10 MILES

FROM time immemorial English schoolboys have been taught to run distances from a very tender age upwards. Such games as paper-chasing and hare and hounds were in vogue long before organised athletic sports were dreamed of, and such events as the Crick Run at Rugby, the Long Pen Pole at Clifton, and the Shrewsbury, Bradfield, Malvern, and Sedburgh steeplechases or cross-country runs were among the first of our regular fixtures. Some of those long runs may be too much for the growing strength of an immature lad, and at Sedburgh no boy is allowed to compete unless he can pass a series of stiff medical examinations.

With this custom as a foundation it was easy and natural for England to produce a race of good distance runners. In England, feats of endurance seem to have been more popular than tests of speed in olden times, and yet when the Oxford and Cambridge Sports started in 1864 there was no flat race of a greater distance than one mile.

In 1865, however, a two miles event was introduced, and in 1868 the two miles was replaced by a three miles event. This was won by the celebrated Oxonian, J. H. Morgan, who trotted home 200 yards ahead of his nearest opponent in 15 mins. 20½ secs. He was the ideal type of distance runner, short and strong, but lightly built with a good deep chest. No one ever got near him in the three years he won the Inter-University race.

R. C. Garnett, C.U.A.C., who won the first English four miles Championship, 1866, in 21 mins. 41 secs., got his blue in 1864

Athletics of To-day

for the two miles Steeplechase, which he won, and he was also second string to R. E. Webster in the two miles of 1865.

In the next period, W. M. Chinnery, referred to elsewhere, produced some great distance running, and in 1872, up to which time four miles had been considered the limit of distance for amateur athletes, W. Slade, a fine, vigorous, upstanding boy, left Tonbridge School and began to puzzle the handicappers, for the further they penalised him the more easily did he win his races. Presently he succeeded in beating J. Scott, L.A.C., the four miles champion of 1871, by fifty yards in a mile at Wandsworth from the fifty yards mark, and in 1874 himself took the English title in 20 mins. 52 secs. Slade stood 6 ft. in height and weighed over 11 stone, and was, therefore, of unusual physique for a distance runner. I have heard it said that he ran very heavily, the cinders fairly crunching beneath his feet as he pounded along. He reached the zenith of his fame in 1875 when he met two other big men, H. A. Bryden and L. U. Burt, at a mile and set up a new record of 4 mins. 24½ secs. In the same year he was beaten in the A.A.A. four miles Championship by James Gibb, L.A.C., in 21 mins. 9½ secs. This led to a great four miles match at Lillie Bridge on April 26th, when the L.A.C. turned out in force to cheer their man, and, it is said, the whole of the younger members of the Stock Exchange, to which institution Slade belonged, arrived to support and, one suspects, to back their man. In that race Slade let the light, springy Gibb make all the pace until he himself came with a great rush in the home straight to avenge his previous defeat and establish a new record of 20 mins. 22 secs.

“Choppy” Warburton, who succeeded Gibb in the English title at the Spring Meeting of 1879, was a North countryman and the hero of a hundred and more thrilling races, but his outlook upon athletics will not commend itself to the modern generation; for, after he became an innkeeper, it was his custom to get into running kit and show himself and his prizes to the admiring yokels for a small fee. W. G. George won the Summer Championship that year.

The next half-dozen years are heavy with the names of such

great champions as W. G. George, B. R. Wise, O.U.A.C., and W. Snook. There is also that splendid light-weight, C. H. Mason, who won the English mile of 1872 in 4 mins. 42½ secs. and the newly instituted A.A.A. ten miles of 1879 in 56 mins. 31½ secs., reducing that time a year later to 56 mins. 7 secs. Mr. Mason, however, may be best remembered by future generations as the founder of the Public Schools Championships, which he started in 1890 by the presentation of a 440 yards challenge cup to be competed for annually by public school boys.

W. G. George, is best remembered for his one mile world's record of 4 mins. 12½ secs., but from 1879 to 1884, when his career as an amateur ended, he had only two serious rivals on the track from one mile to ten miles and over, for he took the English one mile four times, the four miles four times, and the ten miles twice.

B. R. Wise, was tall and slight and did very light training. He was, I think, lucky to catch George just after an illness when he beat him in the English mile of 1881, and George was again off colour when W. Snook, of Shrewsbury, took all three English titles in 1885. Snook was a stronger man than Wise and a more dangerous opponent to George. He was short and thick-set and had terrific legs, shoulders, and chest, and he covered a great deal of ground by copying George's style of shooting the legs straight out from the hips. He was but little inferior to George, but beat him only on the occasions above mentioned.

F. E. Bacon, formerly a private soldier in a line regiment, who won the English four miles of 1894 in 19 mins. 48½ secs. from G. Crossland, Manchester, with whom he indulged in conversation on the way, was a very tall, thin man with an amazing turn of speed. J. Kibblewhite, of Swindon, like Bacon, good for any distance from one mile to ten miles, won six championships by his strength and pluck. Then came the great Sid Thomas of the L.A.C., C. E. Willers, Essex Beagles, and C. Pearce, Birchfield Harriers.

Thomas, a pretty runner with a high springy action, broke records from one-and-half to five miles. He won his first

championships in 1889, taking the English four miles in 20 mins. 31 $\frac{1}{2}$ secs. and the ten miles in 51 mins. 31 $\frac{1}{2}$ secs., and the U.S.A. title at ten miles in 53 mins. 58 $\frac{1}{2}$ secs., and won, in all, one four miles and four ten miles titles. In 1893, however, he was beaten at an open meeting by Willers and Pearce, the former making a new four miles record of 19 mins. 33 $\frac{1}{2}$ secs., and again in the A.A.A. championship four miles at Northampton by Pearce, in the comparatively slow time of 20 mins. 12 $\frac{1}{2}$ secs.

We come now to the halcyon days of Alfred Shrubbs (No. 7, Plate 12). Many people say there never was, and others believe there never will be, another distance runner like him ; for, although better suited at the longer distances, he was a good enough miler to win the English Championship in 1903 and 1904, in which latter year, unfortunately, no British team was sent over to America for the Olympic Games at St. Louis. From 1901 to 1904 he held both four and ten miles track titles and the National Cross-Country Championship without a break, and in the last two years of his amateur career broke practically every possible record from 2,000 yards in 5 mins. 7 $\frac{1}{2}$ secs., to 11 miles in 56 mins. 23 $\frac{1}{2}$ secs. His great two miles world's record of 9 mins. 9 $\frac{1}{2}$ secs. was broken in 1926 by E. Wide, Sweden, who returned 9 min. 1 $\frac{1}{2}$ secs., but Shrubbs's figures from six miles in 29 mins. 59 $\frac{1}{2}$ secs. to ten miles in 50 mins. 40 $\frac{1}{2}$ secs. still stand officially, although Nurmi has applied for a new ten miles record of 50 mins. 15 secs.

The accident of a stack of straw catching fire was responsible for starting Shrubbs on his amazing running career. He was living in the pretty Sussex village of Horsham at the time, and one evening the clanging of the firebell brought him out of doors to see what was happening. The man to whom he directed his enquiry chanced to be F. J. Spencer, of the Horsham Blue Star Harriers. Spencer answered Shrubbs's question and suggested that they should run together to Southwater, three miles away, to see the fire. This seemed rather a tall order to Shrubbs, who had spent the day carrying bricks up a thirty-rung ladder, but, despite working clothes and heavy

boots, he set off, and Spencer did not have to ease the pace a lot to suit him. The result of that run in the dark was an invitation to Shrubbs to join the Blue Star Harriers, whom he left subsequently to join the famous South London Harriers Club.

Of all his races, if you ask him, Shrubbs will tell you that the best was that in which he broke the ten miles and one hour records at Glasgow on November 5th, 1904. He will tell you also that a large blackboard set up in the middle of the ground, with a man on either side to write the time of each mile as it was run, helped him a lot, since he could see it and had always hated to have a raucous-voiced individual shout his times to him as he passed. He attributes a good deal of his success upon that day to the inspiration of the skirling bagpipes. The crowd gave him a great reception as he emerged from his dressing room, but were silent as he waited on his mark. The other runners departed with from one to nine minutes' start of him, but when Shrubbs jumped into his stride the great roar of cheering rose again.

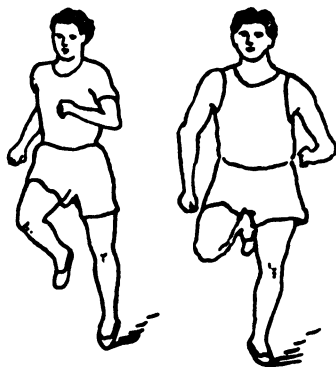

FIG. 6.

Running to schedule, he reeled off mile after mile, but at the seventh mile was behind time. Then came a marvellous quarter mile burst, which set him on the right side. His limbs were moving strongly and freely, and his wind was sound as a bell. In the final mile he caught and passed the limit man; with a quarter of a mile to go he sprinted to the accompaniment of frenzied cheering. As he breasted the tape, for a new record of 50 mins. 40 $\frac{3}{4}$ secs., some one shouted "Go on for [the hour record," and, although he was feeling the reaction from his final spurt, on he went to make a new one hour amateur record of 11 miles 1,137 yards. After that the spectators broke on to the ground and bore him shoulder high to the pavilion to the singing of "Will ye no come back again?"

As a professional Shrubbs ran some amazing and amusing "freak" matches. On the road he beat two horses, each going five miles, in a ten miles match, and, indoors on board tracks, he took on a relay team of five men, each to run two miles, while he himself went the full ten; and again taking on three men, each to run two miles, while he ran six miles; and in every instance Shrubbs emerged victorious.

Shrubbs caused something of a sensation and a good deal of amusement when he met Billy Sherring, who had won the 1906 Marathon at Athens, in a fifteen miles match at the Baseball Ground, Buffalo, U.S.A. In that race Shrubbs broke the tape six laps ahead of his Canadian opponent, dashed off to his dressing room to secure his camera, and strolled back to take a snapshot of his opponent finishing. The crowd were delighted, and the newspapers made much good "copy" out of the incident.

The late Sergt. G. W. Hutson showed every promise of proving himself a worthy successor to Shrubbs, but a German bullet cut short his career in the early days of 1914. He was English four miles Champion in 1912, 1913 and 1914, and I shall always remember him for the amazing race he ran in 1913 when he reduced the championship record to 19 mins. 32 secs., a performance never since approached, and ran the last quarter mile lap of sixteen laps in 60 secs. flat.

Meanwhile America had taken up distance running, but not with the same enthusiasm as was accorded to sprinting. In 1899, twenty-three years after both championship meetings had started, A. Grant, Pennsylvania University, won the first Inter-Collegiate two miles in 10 mins. 3½ secs., and the first national (indoor) title in 10 mins. 4½ secs. In 1880 the A.A.U. of America instituted a five miles, won by J. H. Gifford, Irish-American A.C., in 27 mins. 51½ secs., and in 1889 Sid Thomas went over from England to win the first American ten miles in 53 mins. 58½ secs., a time only once beaten or even nearly approached for the next twelve years, except by E. C. Carter, N.Y.A.C., who returned 53 mins. 40½ secs. in 1893.



PL. 11]

Physical and Sport and General [G 30

THE MILE.

1. P. Nurmi, Finland, World's Record holder. Note arm and shoulder action, shoot of lower leg and low pick up of rear heel. 2. Nurmi beating Hahn. Note difference in action. 3. A. G. Hill beating H. B. Stallard and breaking British Record. 4. C. Ellis winning English Mile Championship. 5. T. Banks, former Mile Record holder.



PL. 127

C. I. Topdell and Sport and General 1197

THE DISTANCES.

1. H. Kohlhmannen, Finland, correct road running action. 2. Kohlhmannen, good distance finishing form. 3. B. C. V. Odde, Great Britain. Note low arm carriage and drive from ball of foot. 4. J. E. Fowler-Dixon, 40 Miles Record holder. 5. A. F. H. Newton, 30 to 100 Miles Road Record holder. 6. W. G. George. 7. A. Shrubbs.

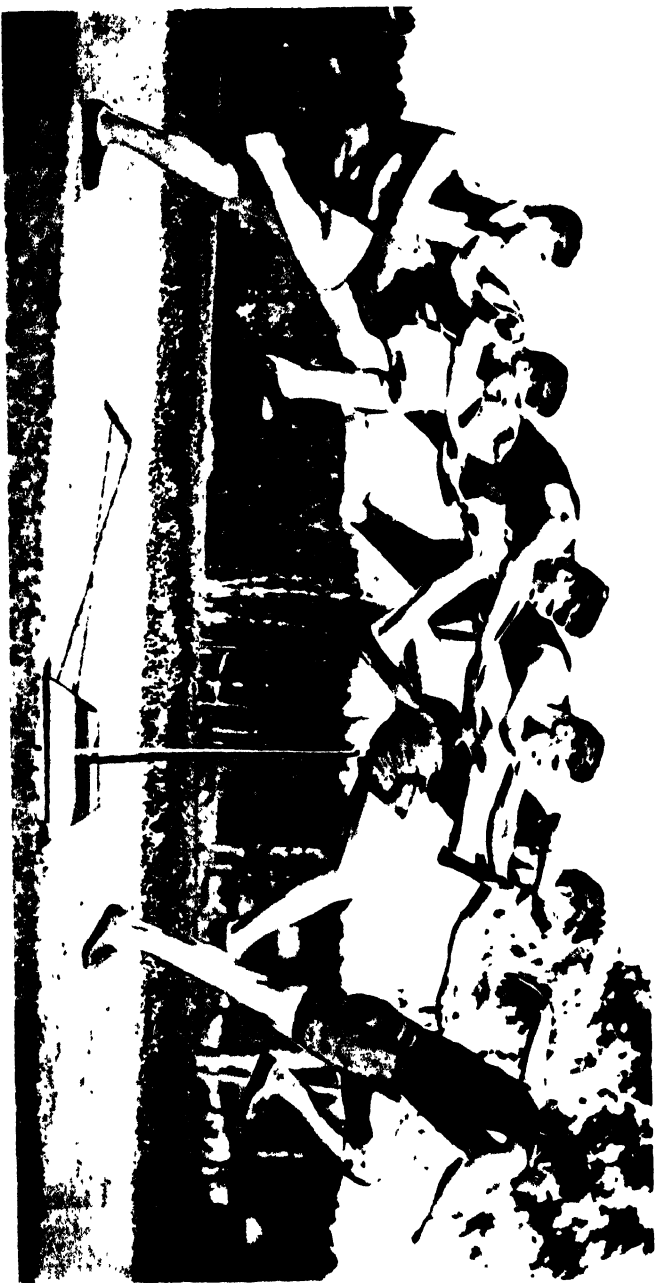

Pl. 103

THE HIGH HURDLES

I FROM TAKE-OFF TO LANDING

Sport and General (A 127)

This composite picture shows the perfect clearance action of Earl Thompson, (Canada, the World's Record holder



PJ. 15] *Finnish Official*

Sport and General [I 128

GREAT MARATHON MEN.

1. H. Payne, Great Britain, English champion 1928. 2. S. Ferris, Great Britain, English champion, 1925, 1926, 1927. 3. P. Dorando helped past the post, 1908. 4. H. Kolehmainen, Finland, Olympic victor, 1920. 5. P. Dorando as he is to day. 6. A. Stenroos, Finland, Olympic victor, 1924

The Distances—2 to 10 Miles 97

Towards the end of the last century the records in England and America compared as under :

	<i>British</i>		<i>American</i>	
		m. s.		m. s.
2 Miles	W. G. George	9 17 $\frac{3}{8}$	A. Grant	10 3 $\frac{3}{8}$
4 „	E. C. Willers	19 33 $\frac{1}{8}$	W. D. Day	20 15 $\frac{1}{8}$
5 „	S. Thomas	24 53 $\frac{3}{8}$	E. C. Carter	25 23 $\frac{3}{8}$
10 „	W. G. George	51 20	W. D. Day	52 38 $\frac{3}{8}$

From those days, I fancy, the development of distance running in the two countries has followed lines diametrically opposite. We have continued to build up from the lesser distances, and the Americans have built down from the Marathon event, which had an enormous vogue in America after Johnny Hayes had won the 1908 Olympic title over the course from Windsor to London.

At the London Olympiad British distance men still ruled the track, little Emil Voigt, who stood but 5 ft. 5 ins. and weighed 9 stone 4 lb., winning the five miles Olympic title from his fellow Mancunian, Eddie Owen—5 ft. 7 ins. and 9 stone 7 lb. stripped—by 70 yards in 25 mins. 11 $\frac{1}{8}$ secs. J. F. Svanberg, a thirty years old Swedish athlete who stood 5 ft. 6 $\frac{3}{4}$ ins. and stripped at 9 $\frac{1}{2}$ stone, was third however, and the writing was on the wall for those who had eyes to read with.

Before the Fifth Olympiad was held at Stockholm in 1912 the late Jean Bouin began to improve the French distance records, and in 1911 a quiet, unassuming little runner from Helsingfors, Finland, arrived in England just before the championships. This lad, Hannes Kolehmainen (Pictures Nos. 1 and 2, Plate 12) had one or two trial spins at Stamford Bridge, and those of us who were privileged to watch him at work went away wondering, for we had seen a new world's champion, and we knew it. That year, Kolehmainen took the English 4 miles in 20 mins. 3 $\frac{3}{8}$ secs. (he is seen winning in Picture 2, Plate 12),

and his beautiful, free-moving, machine-like action pleased the crowd mightily. After that race, and having regard to statistics, no man dared predict whether Frenchman or Finn would win Olympic laurels in the following year. Our own hope was that George Hutson, English champion in 1912, would find some great running at 5,000 metres, and that E. Glover and W. Scott would be there or thereabouts at double the distance. America had a good contender in G. V. Bonhag, who had won national titles at five and ten miles.

As things turned out, Hannes Kolehmainen was to prove himself the outstanding feature of a great festival. I was new to Olympiads then, for Stockholm was only my second, although I have since been to Antwerp, Paris, and Amsterdam, but even then I had seen some great distance runners, but Kolehmainen was different, because he was the next best thing to inexhaustible. He had taken up running because he had read interesting accounts of previous Olympiads, and he had trained himself on what he had read in books. He was amazingly unassuming, but his wonderful smile and his whole-souled enthusiasm endeared him to all of us. The heats and final of the 10,000 metres he won so easily, the latter in 31 mins. 20½ secs., that he was able to wait and watch the second man finish. His heat of the 5,000 metres he walked away with, but the final was a different matter. Bouin, Bonhag, and Hutson pushed him hard the whole journey, but that long stride of the little man, which came from spring and not from striding out, wore them all down, until the Englishman and American were dropped, and Bouin, losing his form, was brought back and passed, with the Finn winning in 14 mins. 36½ secs., while Hutson finished ahead of Bonhag. These were both Olympic records, but the Finn was not through yet, for he won his heat in the 3,000 metres Team Race and finished first in the 8,000 metres Cross-Country race. In 1920, having served right through the War, he went to Antwerp and won the Marathon Race of 26 miles 385 yards, and ran again at Paris in 1924.

The post-War period has produced such good distance men in

The Distances—2 to 10 Miles 99

England as H. Britton, E. Harpur, C. E. Blewitt, Corporal Cotterell, Wal. Monk, W. Beavers, W. R. Seagrove, H. A. Johnstone, A. T. Muggeridge, J. E. Webster, H. W. Payne, E. A. Montague and B. C. V. Oddie. Most of them have won A.A.A. titles, all of them have gained international colours, but not one has proved himself as good in the Olympic arena as was George Hutson. It may be said, indeed, that world mastery at the distances from 1,500 metres to the Marathon Race of 26 miles 385 yards, and possibly including that distance, has passed definitely into the hands of Finland for the time being. Kolehmainen at Antwerp had in the team with him the man upon whom his mantle was to fall—Paavo Nurmi. And Nurmi, curiously enough, found his most dangerous opponent at Antwerp to be the successor of Jean Bouin, who had fallen in the War. J. Guillemot, France, however, beat Nurmi at 5,000 metres, but was beaten by him in the 10,000 metres.

Before the Paris Olympiad arrived, Nurmi (see Plates 11 and 23) had shattered the world's 1 mile record completely, and just before the Games Willie Ritola (see No. 1, Plate 23) returned to Finland from America, where he had won the 10 miles Cross-Country Championship and had set up new American records at three and four miles, the former on an indoor track. This pair at Paris swept all before them and their chief rival was Edvin Wide, of Sweden. Nurmi won the 1,500 metres, the 5,000 metres from Ritola and Wide, and finished ahead of Ritola in the 3,000 metres team event and the 10,000 metres Cross-Country race. In three of these races he beat Olympic record. He did not run in the 10,000 metres flat race or the 3,000 metres Steeplechase. In the former Ritola again beat Wide in the new world's record time of 30 mins. 23½ secs., and again broke world's record in the Steeplechase, which he took from E. Katz, Finland, in 9 mins. 33½ secs. Of the sensational happenings in the Cross-Country race I shall write in a later chapter.

Nurmi finished off that year with a blaze of record-breaking in October and November. His world's records made then and

Athletics of To-day

subsequently, of which those at 3, 4 and 5 miles have been accepted officially, are as follows :

Miles.	Mins.	Secs.	Miles.	Mins.	Secs.
3	14	11½	7	35	4½
4	19	15¾	8	40	16
5	24	6½	9	45	27¾
6	29	59¾	10	50	15

On October 7th, 1928, at Berlin he ran 19 kilometres, 210 metres (approximately 11 miles 1,636 yards) in 1 hour, thus eclipsing the record of 11 miles 1,442 yards in an hour made by the late Jean Bouin, France, on July 6th, 1913, at Stockholm. It was during this race that Nurmi put up his ten miles world's record of 50 mins. 15 secs. Judging from what happened at Amsterdam in 1928, and having regard to the history of Stockholm, Antwerp, and Paris previously, we may expect to find new Finnish world-beaters maturing every four years, before their predecessors have laid aside their laurels. Kolehmainen saw Nurmi and Ritola arise before his own star had set, and they, in their turn, had to share the honours of the ninth Olympiad with newer prodigies.

In Holland, Nurmi and Ritola met at 5,000 and 10,000 metres and changed round the titles they had won at Paris, finishing one behind the other and the two of them ahead of the unfortunate Edvin Wide in both races. They met again in the 3,000 metres Steeplechase, but here Nurmi was beaten by a younger Finn, T. A. Loukola, and Ritola did not finish. Nurmi allowed his 1,500 metres laurels to go by default, his successor being H. E. Larva, and yet another Finn, E. Purje, finishing third.

In running Nurmi has been a law unto himself. When he went to America after the Paris Games he amazed all the American coaches by his methods and set them all shaking their heads when he limbered up for a five miles race half-an-

hour before it was to be run by trotting a steady two miles. Later the same evening he turned out for his second race and appeared munching a large apple. The American track "fans" sat back flabbergasted, and the coaches prayed under their breath that no young Americans would emulate such madness—but Nurmi won just the same. His strength and his $8\frac{1}{2}$ ft. stride scorned all opposition. To attempt to argue how he would have fared against such men as W. G. George or Alfred Shrubbs at their best is as profitless as trying to solve the problem of what would happen if an irresistible force should meet an immovable object. No one of them lived in the same athletic age, and that is all there is to it.

"Chesty" Joie Ray has been a big disappointment to America at two Olympiads, but the fact of the matter is that he could not get acclimatised in Europe, added to which his best distance was undoubtedly two miles, and there is no 3,000 metres individual race in the Olympic programme. In 1924 he elected to go for the 1,500 metres, and in 1928 it was the Marathon Race that attracted him, but at neither distance could

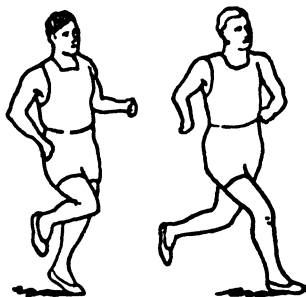

FIG. 7.

he make good. That such an athlete should turn to the Marathon is amazing, for he has held the American half mile title once, the mile eight times, the two miles (indoors) twice, and the five miles once. The U.S.A. mile record of 4 mins. 12 secs. still stands jointly in Nurmi's name and his, but there is an amusing tale to tell of the day he broke Shrubbs' two miles' record of 9 mins. $9\frac{3}{4}$ secs., which had stood since 1904 and was still the official record until Wide ran $8\frac{3}{4}$ secs. faster in 1926, because Ray's race was run on an indoor board track, and, therefore, never went on to the books. Four laps from home on that occasion Ray was over two seconds behind Shrubbs' time according to his schedule. At that point Eddie Mayo, his trainer, who used to hold the watch at all Joie's races, tore up

Athletics of To-day

his time-card with a gesture of disgust as Ray came abreast. Ray took the hint. For once in his life he saw red. Anger lent wings to his flying feet, and those who witnessed the running of those last four laps will never forget the sustained burst of speed he pulled out. Anyway, it was fast enough for the time-keepers' watches to show 9 mins. 8 secs.

That world's indoor record was eclipsed on February 14th, 1925, at New York City by Paavo Nurmi, who returned the amazing time of 8 mins. 58½ secs., an even more startling performance than Wide's official outdoor record of 9 mins. 1½ secs. One might add that all the American distance records, both indoors and out, from a mile in 4 mins. 12 secs., which Nurmi shares with Ray, to 11 miles 153 yards in the hour by Albin Stenroos, Finland, are held by H. Kolehmainen or W. Ritola, except the 2 miles (outdoors), T. S. Berna, 9 mins. 17½ secs., and 5 miles (outdoors), C. Pores, 24 mins. 36½ secs.

Speaking generally, small, light men make the best distance runners ; Shrubbs and Kolehmainen both come into this group. George and Ritola belong to the tall, thin type, with a stride, I suppose, of over 8 ft. ; while Bouin, Nurmi (striding 8½ ft.), and Wide (striding 9 ft.) are of the thick-set, burly build. Ray was lighter than any of them and found his stride limit at 7 ft.

The matter of finding his *métier* must always provide the distance man with a nice problem, since, with a few noteworthy exceptions, the real miler can usually run a pretty useful four miles, and the man who can go that distance seldom has much trouble in returning a good time at ten miles. To add further to these perplexities, distance men who have enjoyed track or cross-country success are now turning their attention to Marathon running. H. Kolehmainen, H. Payne, E. Harper, and Joie Ray are good examples of this new class.

TRAINING

The basis of training for distance running is long, strong preliminary work for a month. During that time walks of eight to twelve miles at four miles an hour, and slow jog-trot

The Distances—2 to 10 Miles 103

runs at little over walking pace of two to four miles three times a week are the order of preparation. One long walk a week should be taken right through the whole period of training. In the preliminary period alternate walking and jogging, study to correct faults, and devote five or ten minutes a day to body-building exercises. A course of cross-country running through the winter months is probably the best preparation for achieving good distance performances on the track during the summer. Judgment of pace is, of course, of the first importance and the runner must build up his time schedule according to his ability and the distance he is planning to run. When Ray made his sensational two miles indoor record his intermediate times were as under :

	440 yds.	880 yds.	1,320 yds.	1 mile
	62 $\frac{2}{5}$	2.11 $\frac{3}{5}$	3.22	4.29 $\frac{2}{5}$
Per $\frac{1}{4}$ mile	62 $\frac{2}{5}$	69 $\frac{1}{5}$	70 $\frac{2}{5}$	67 $\frac{2}{5}$
	2,200 yds.	2,640 yds.	3,080 yds.	2 miles
	5.39 $\frac{1}{5}$	6.48 $\frac{3}{5}$	7.59 $\frac{2}{5}$	9.8 $\frac{2}{5}$
Per $\frac{1}{4}$ mile	69 $\frac{1}{5}$	69 $\frac{2}{5}$	71 $\frac{1}{5}$	68 $\frac{2}{5}$

The merit of Ray's regular running may be seen by comparing it with the table of great mile times on page 82.

The man who aspires to run two miles in 10 mins. should aim at running the first quarter mile in 70 secs., allow 75 secs. each for second to sixth inclusive, rest a bit by running the seventh quarter mile in 80 secs., and try for the eighth and last quarter in 75 secs., from which he may happen to knock off another 5 secs. if he is pushed hard.

When racing form is reached, plan your training schedule so that you run between two and three miles on Monday to build up stamina ; a fast mile-and-a-half on Tuesday, concentrating on judging speed ; devote Wednesday to a six miles walk at normal speed, and Thursday speed up, by running two miles

in alternate fast and slow quarter miles ; Friday, rest ; Saturday, race or time trial.

In an earlier paragraph a schedule for two miles in ten minutes is given, because the pace the distance men must work for is the average speed of each mile in five minutes. This statement needs a little qualification, for a five minutes' mile average would not have been fast enough to win the A.A.A. four miles in any year since 1920 when C. E. Blewitt returned 20 mins. 10 $\frac{1}{2}$ secs., and is too hot a pace for most men, although Nurmi averaged approximately 5 mins. 1 $\frac{1}{2}$ secs. per mile when he made his world's ten miles record of 50 mins. 15 secs. Since 1907 the A.A.A. ten miles has been won outside 54 mins. only once, on eight occasions 52 mins. has been beaten, and in 1913 E. Glover returned 51 mins. 56 $\frac{1}{2}$ secs. In preparing schedules for ten miles, runners should remember the following figures :

An average of 440 yds. in 1 min.	18 secs.	equals 10 miles in	52 mins.	0 secs.
"	"	" 1 "	" 19 "	" 52 "
"	"	" 1 "	" 20 "	" 53 "
"	"	" 1 "	" 21 "	" 54 "

An even pace should be sustained throughout ; any improvement in the time beyond the schedule will come through speeding up to pass opponents and in the finishing burst, which should be built up to cover 440 yards if possible.

The walking exercise advocated should consist of brisk walks and not mere strolls. The four-miler should run at one-and-a-half to two-and-a-half miles in training with an occasional spin over the full course. The ten-miler should go for plenty of long, fast walks, take occasional runs of five miles and, but less frequently, six, seven and eight miles, with a full course trial now and then.

In running the arms are carried with hands loosely closed and swinging naturally across the stomach, the arms swinging inwards and outwards as the opposite legs are raised or lowered, as in Nos. 1 and 3, Plate 12. You can prove for yourself how much the action of the arms helps the stride. First let your arms hang down at the sides and take a step forward ; then put your hands at the pit of the stomach and take another stride,

The Distances—2 to 10 miles 105

and you will find that, with the same amount of effort, you have achieved a longer stride. The back foot in each instance must be kept grounded as this test is made.

Leg action and foot work are important. The distance runner does not aim at great length of stride, but often commits the fault of placing the heel down first. This is wrong. The sole of the foot should make first contact with the track (see No. 1, Plate 12 and Nos. 1 and 2, Plate 23); then the heel sinks and touches the cinders very lightly, and the foot rises again on the sole as the other leg swings through for the next stride forward (see No. 3, Plate 12). This action is just as important as the "ankling" movement in cycling or jumping. Keep the head set in an easy, natural position as you run, as shown in Plates 12 and 23.

The finishing speed is built up by completing each training run with a sprint, starting at 50 yards and increasing the final sprint distance to 440 yards if possible as your fitness improves. Note the perfect form in which Kolehmainen finished when he won the A.A.A. four miles championship in 1911 (No. 2, Plate 12). Nurmi, as great a distance runner as any, is a law unto himself, as his pictures prove.

CHAPTER VII

RELAY RACING

To this phase of athletic competition America owes a great deal of the phenomenal success and many of the world's records of her sprinters and quarter-milers. The popularity of relay racing in America has had another very beneficial effect on national athletics. With each fresh season the varied relay races bring to the notice of the American coaches a number of runners who are capable of fine performances, although not quite up to championship standard. These men get their places in the relay teams and they invariably train on. In consequence of this America is always able to bring extraordinarily well balanced teams to the Olympic Games, and if a first-string man breaks down, or meets with an accident, there are invariably three or four men, very nearly as good as he is, to take his place.

Relay racing was started in America in the early nineties of the last century and added an amount of interest to the war that has been ceaselessly waged against the growth of the individual spirit, as opposed to the team spirit, in competitive athletics. The University of Pennsylvania Relay Meet, which is still the greatest festival of its kind, was the first such meeting ever instituted. This was in 1895. In 1897 the New York A.C. Relay Team (M. W. Long, H. S. Lyons, T. E. Burke and B. J. Wefers) won the American One Mile Relay Championship (4 x 440 yards) and made a world's record mark of 3 mins. 21½ secs. These were four magnificent quarter-milers, but how does the time compare with the present world record of 3 mins. 13½ secs. made by the American team (G. Baird, 49½ secs., F. M. Taylor, 47½ secs., R. Barbutti, 48 secs., and E. Spencer,

48 $\frac{3}{4}$ secs.) in the British Empire *versus* U.S.A. match at Stamford Bridge, London, on August 11th, 1928 ?

In 1896 there were fifteen relay races at the University of Pennsylvania Meeting and more were added in 1897, while the Boston A.A. in 1896 staged a meeting of eight events, increased to ten in 1897 and to eleven in 1898. And of all the teams entered in those sixty-two races there were only three or four that did not represent some school, college, or university. In 1921 no fewer than 3,300 competitors' tickets were issued for the University of Pennsylvania Relay Meet, and more than 300 preparatory schools and 112 colleges were represented. Eighty events were decided in the course of two afternoons, including a pentathlon contest and several of the field events, which always take a good time to get through. In 1927 the Pennsylvania Meeting included eleven College Relay Championships of America, seven School Relay Championships of America, and thirteen special individual events, and the entry grows to greater proportions year by year. In 1907 Wisconsin founded a set of indoor relays.

In England nothing of this sort was ever seen at the Championships until a 1 mile Medley Relay event (880 yds., 220 yds., 220 yds., and 440 yds.) was instituted in 1911. This was altered in 1922 to a mile in which each of four runners travels 440 yards, and in 1927 a new 440 yards Relay Championship (4 x 110 yds.) also was added to the programme. The mile relay title has never gone abroad, but the first two championships at 440 yards were won by German teams, this form of athletic competition having become extremely popular in Germany since the War.

At the Olympic Games there are three relay events—1,600 metres (men), instituted in 1908 and 400 metres (men), instituted in 1912. Great Britain has won each of these titles once, America proving successful on all other occasions. The women's 400 metres event (4 x 100 metres) was instituted in 1928 and won by Canada (F. Rosenfeld, F. Bell, E. Smith and M. Cook) in the new world's record time of 48 $\frac{3}{4}$ secs.

The real progress of relay racing in England is largely due

Athletics of To-day

to the foundation of the Achilles Club, which, as stated already, has for one of its main objects the encouragement of relay racing and team competition. The Inter-County Track and Field Championship Meeting is entirely a team and relay affair, as is also the Victory Cup Meeting, held annually at Woolwich, and there are The Services Inter-Unit Team Championships in athletics as well. I think that British interest in relay racing and team competition really had its inception in the first great athletic match ever held between the British Empire and the United States of America, which furnished a clear-cut issue, not only between the English-speaking peoples, but between the nations that have been responsible for the revival of competitive athletics in modern times.

At Antwerp during the seventh Olympiad the very friendliest relations had prevailed between the Americans, our Dominions, and ourselves. I do not know for certain who was the genius who first suggested that a match between the British Empire and America should be held in London immediately after the Games, but I fancy that Brigadier-General R. J. Kentish, C.M.G., D.S.O., Lieut.-Col. A. N. S. Jackson, D.S.O., P.J. Baker, and B. G. D. Rudd, all had a finger in the pie. Anyway, the meeting was organised by the Achilles Club and held at Queen's Club, London, on September 4th, 1920, and no athletic meeting ever before held in England had aroused such whole-hearted enthusiasm. Great credit is due to P. J. Baker, C.U.A.C., and B. G. D. Rudd and W. R. Milligan, O.U.A.C., for the enormous amount of work they put in, nor did they spare themselves in organisation upon the day, and perhaps Baker, who had run his first race sixteen years earlier, and Rudd, who had won the Olympic 400 metres at Antwerp, depreciated their own running a little through that circumstance.

That match, at which there was not an inch of standing room among the spectators at Queen's Club, consisted of five relays, one team race, and four individual contests, and it ended in a draw, but the man who really saved us from defeat was B. Howard Baker, that magnificent high jumper, who had not been able to find his true form at Antwerp, but now, with a

jump of 6 ft. 3½ ins., defeated R. Landon, U.S.A. by an inch, the American having taken the Olympic title at 6 ft. 4½ ins. In the British team that day were Englishmen, Irishmen, Scotchmen, and Welchmen, Australians, Canadians, South Africans, and New Zealanders, and every one of them gave of his best for the sake of the Empire.

The second meeting between the great rival forces in athletics took place at Stamford Bridge, London, on September 25th, 1924, after the eighth Olympiad at Paris and was witnessed by 22,000 people. Upon this occasion all the races were of the relay order and all the field events were team competitions in which the aggregates of the contestants supplied the scores of each side. The Empire lost by eleven events to three events, because our field events men were completely outclassed and our runners had not practised the passing of the baton. But for the latter piece of bad staff work we might have won five or six events instead of only three.

The third meeting took place, again in London, on August 11th, 1928, following the ninth Olympiad at Amsterdam. This time our field events men showed marked improvement and our hurdlers should have been equal to the task set them, but a rough track and over-anxiety brought them to grief, and bad baton changing in the flat races was again the major fault which brought us to disaster, America winning by eight events to six events. Forty-one thousand people, the second largest crowd ever seen at an athletic meeting in England, witnessed the match. In the Mile Relay, America returned 3 mins. 13½ secs. and the Empire 3 mins. 15½ secs., both times beating the previous world's record. In the 400 metres Relay, the American team, which only won by inches, equalled the world's record of 37½ secs., and in the Mile Medley Relay (440, 220, 220 and 880 yards) the British Empire team made a new record of 3 mins. 22½ secs. New British records were established in the Long Jump by E. B. Ham, U.S.A., 25 ft. 1 in., and in the Pole Vault by L. Barnes, U.S.A., 13 ft. 9 ins.

Perhaps the greatest triumph ever achieved by a British relay team, not excluding our two Olympic wins, was the

Athletics of To-day

world's record of 7 mins. 50 $\frac{3}{4}$ secs. for 2 miles (4 x 880 yards) made at Franklin Field, Philadelphia, on May 1st, 1920, by the combined Oxford and Cambridge Team (W. G. Tatham and H. B. Stallard, C.U.A.C., and W. R. Milligan and B. G. D. Rudd, O.U.A.C.) when they went to America to compete at the University of Pennsylvania Relay Meet.

In the main, our Empire teams, both club and national, do not do so well as they should through insufficient training as teams. We had a shocking example of this in the 1,600 metres relay event at Amsterdam in 1928. Individually our men are good enough at their own distances, but they seem to lack the genius for judging the finishing power of an incoming runner, and they do not put in nearly enough time in perfecting the standing start and that all-important feature of the game, the passing of the baton. The Polytechnic Harriers are, perhaps, an exception to this opinion, and, no doubt, things have improved a good deal since the Oxford and Cambridge Relay Meeting, which takes place annually in the Christmas Term, was instituted in 1920.

With the training of the men for running their individual distances, it is unnecessary for me to deal, since each event is discussed separately in other parts of this book. Two things the captain of a relay team must know (1) the exact abilities of his own team, and (2) as much as he can find out about the quality of the teams by which his own will be opposed. With that knowledge to guide him he has then to decide the order in which his team is to run. And, even so, he may have to change his plans at the last moment, the better to combat the arrangement of an opponent's team. For this reason I am not in favour of the plan, sometimes recommended, of training a team to run in a definite order and to come up on alternate sides of the outgoing runner to save the trouble of changing the baton from one hand to the other. (See No. 4, Plate 13, where the incoming runner of the leading pair has handed over from the left side of the outgoing relay.) When this plan is adopted, No. 1 never practises the standing start, No. 4 practises receiving the baton but does not learn how to hand it over, and Nos. 1,

Relay Racing

111

2 and 3 learn only to make the exchange from one particular hand.

If the opposition is going to put their fastest man to run the first, say, 440 yards, the captain has to ask himself two questions—(1) Have I a man who is as fast? (2) If not, which of my own men is least likely to be discouraged by the lead the other fellow will establish, *i.e.*, who is least likely to let the flyer get right away, and who is my best man to run the second leg? Of late years it has become almost a convention to allot the first leg to the second best man, put the slowest man second, the third best man third, and the fastest man last. This method undoubtedly gives the team its best balance and will certainly upset the opposition should they adopt the old method of running their men in the reverse order of merit, that is to say, worst man first and best man last. This discussion does not relate to Medley Relays, in which the order of running is virtually determined by the programme order of the distances.

In the final issue, success in relay racing is contingent largely upon the pace-judgment of the men and their ability to run at the best speed they know they can hold, whether they are leading or not. If a man is leading he should safeguard the interests of his team by still running true to the best of his form. If he is behind he must still run true to the best of his proven ability. If he tries to gain back the distance his team has lost by a too great burst of opening speed he will outpace himself and be "all-in" before two-thirds of his course is covered and thus will serve his side worse than if he had stuck to the pace he knew that he could keep up.

Accurate baton passing without loss of time is as important as pace and the knowledge thereof. The baton may be passed anywhere within a twenty yards zone, and the object is to hand it over to the next man in such a way that neither man loses speed nor the team its accumulated momentum. The outgoing runner needs judgment to determine in what part of the zone he should take over. If the incoming runner is pretty well foundered, the exchange should take place in the first ten yards

Athletics of To-day

of the zone, but if he is finishing strongly the outgoing man may get faster into his running and take over the baton nearer the front limit of the zone. The receiver must watch the incoming man to judge his condition, but when he has made up his mind about this he should be on the move forward with head and eyes to the front when the transfer is made.

The question of how the hand that receives the baton should be held is a vexed one. In the standard method the incoming relay, holding the baton by the lower end, leans forward on his last stride and with left arm at full stretch brings the upper end of the baton down into the right hand of the outgoing relay, who has his right arm stretched out behind him at an angle of about 45° downwards, his hand being turned at the wrist so that the palm is uppermost (see Fig. 8a). But I think a better and a

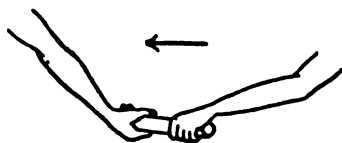

FIG. 8a.



FIG. 8b.

safer method is that in which the receiver crooks his right arm at the elbow, as shown in Fig. 8b, and bends his wrist so that the knuckles of the middle joints of the fingers are level with his right hip. This allows him to keep his shoulders square to the front and also facilitates a quick and easy forward arm swing as soon as he has grasped the baton.

The man handing over should come in on the right of the receiver, and the latter should transfer the baton, which he has received in his right hand, to his left, either at once (see Nos. 2 and 3, Plate 14) or within the first fifty yards of his run. He has taken it in his right hand by the upper end and should transfer it to his left hand with an over arm movement—like the action of a man sheathing a sword—so that the left hand is



BRITISH EMPIRE



USA 1928



174. 13.

WHEELS A.C. 7. WASEDA UNIVERSITY, 1928. *Sport and General* [H 112

1. The victorious American team. 2. The British Empire team, led by D. G. A. Lowe, S. J. M. Atkinson, P. Williams and Ford Burghley, Empire victors at Amsterdam, 1928. 3. The victorious 140 yards relay team.

4. Baton changing Nambu handing over to Yamaguchi.

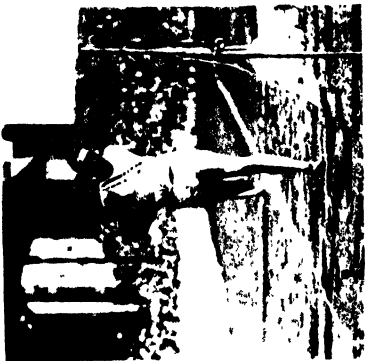
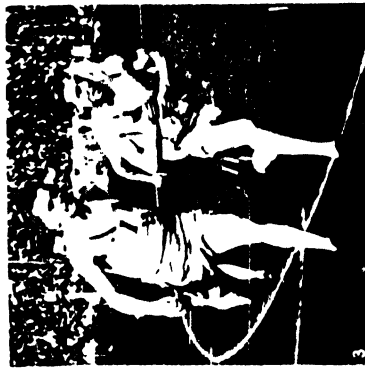

PL. 14

BRITISH EMPIRE v. U.S.A., 1928.

Sport and General

| 113

1. Four miles relay. C. Elbs, B.E., winning from L. Hahn, U.S.A. 2. One mile relay. R. Leigh-Wood, No. 7, taking over from J. W. J. Kinkel, B.E., and R. Barbutti from F. Morgan-Taylor, U.S.A. 3. Four hundred yards relay. T. Quinn taking over from F. Wykoff, U.S.A. 4. One mile relay. E. Spenser, U.S.A.

able to grasp the baton by the lower end and thus have it rightly disposed to pass on to the next man. In No. 2, Plate 14, Leigh-Wood (7) has used this method and is going straight ahead, whereas Ray Barbutti, U.S.A. (3) is making a cross-body transfer which is throwing him right off the track to his left. The final relay will be well advised to retain the baton in his right hand, for then he lessens the risk of dropping it, but it is surprising how many men transfer it to the left hand through sheer force of habit. The man who hands on the baton is responsible for effecting a good transfer. He should not poke the baton at the receiver, but swing it cleanly into his hand with a downward movement from his last upward arm swing and should, therefore, strive to make the exchange on the left leg stride.

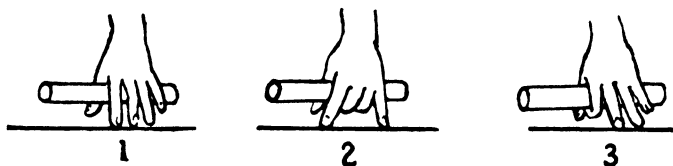

FIG. 9.

As the waiting relay cannot, for obvious reasons, use the crouch start position, all members of the team should be given considerable training in the old-fashioned standing start action. The man to run the first leg can and of course will use the crouch start, and so must make up his mind how he is going to hold the baton when his hands are on the scratch line in the "On the Mark" and "Get Set" positions (see Nos. 1, 2 and 3, Plate 5, Chapter II, and Fig. 2, page 51 for normal finger spread tripod position). It is assumed that he will start with the baton in the left hand, to avoid the risk of passing it from one hand to the other. Sketches 1, 2 and 3 in Fig. 9 show three methods of grasping the baton in the starting position.

No. 1 shows a good position, from the runner's point of view, because it allows the fingers and thumb to make contact with the ground, as in the standard tripod spread, but length of fingers is needed; otherwise the baton will not be retained

easily by the grip between the thumb and forefinger knuckle joint alone.

No. 2 shows a safer grip of the baton, but is inclined to spoil the balance of the start, because the athlete cannot make his left hand help to support the weight equally with his unimpeded right hand. Consequently he may tend to fall to his left as he pushes off at the crack of the pistol.

No. 3 illustrates the hold I am inclined to recommend, because the curling round of the first finger and the squeezing pressure of the ball of the thumb are bound to hold the baton in place, and at the same time the thumb and all the fingers, except the first finger, are enabled to make contact with the track surface.

The man who runs the first relay is advised to carry a thick running cork in his right hand to equalise grip and balance. He must grip the baton as he pushes off ; otherwise it may fly out of his hand as his left arm is swung vigorously to aid the first few strides forward.

There is no phase of athletic sport which is so fruitful in " form " surprises, and not once, but many times, has a man, who is but a mediocre performer in individual contests, put up a time in a relay which has amazed himself and every one else. This usually means that he is more gifted with imagination and more susceptible to the excitement of contributing to the victory of his team than are some more phlegmatic runners, and it is this peculiar sort of nervous force that team captains should be on the look-out for when choosing their teams.

CHAPTER VIII

THE MARATHON RACE

THE Marathon Race, now standardised at 26 miles 385 yards, was instituted at the revival of the Olympic Games at Athens in 1896 to commemorate the epic endurance of a Greek soldier, Pheidippides, who in 490 B.C. ran from Marathon to Athens, a distance of 22 miles 1,470 yards, to bring news of his countrymen's victory over the Persian hordes under Darius who had sought to invade Greece. But that, however, does not tell the full tale of his prowess. When the news reached the Athenian elders that Darius, the Mede, was crossing the Ægean Sea to conquer the Greek states they dispatched Pheidippides, a noted Olympic champion, to summon aid from the Spartans. That journey took him two days and two nights, and in its course he climbed mountains and swam rivers. The Spartans, however, refused to set out until the moon should be at the full, and so Pheidippides journeyed back. Meanwhile the Persians had landed, and he reached the capital only soon enough to deliver his message and take up his heavy shield and long spear, before setting out with the Grecian army which was marching to meet the invaders at Marathon. Pheidippides bore his part in the battle, and immediately it was over and victory assured he cast aside his arms and set out to run the twenty-two odd miles to the capital with the news. At the outskirts of Athens he was met by the elders and gasping out the words that mean "Rejoice, we conquer!" he fell dead at their feet.

By a curiously appropriate chance the man who won the first Marathon Race of modern times was a Greek peasant named Loues, and of course the delight of his Greek com-

patriots knew no bounds. The time he took to cover 24 miles 1,500 yards on the rough and dusty roads of Greece was 2 hours 55 mins. 20 secs., and when he trotted into the stadium the whole great concourse rose to him as one man. Women tore off their jewellery and flung it at his feet, a little urchin pressed forward with an offer to clean his shoes thereafter for nothing, and a hotel proprietor presented him with an order for 365 free meals. But for the intervention of the Greek princes Loues might well have shared the fate of his great predecessor. But when the press of wildly enthusiastic spectators became too great the Crown Prince and Prince George of Greece picked him up and carried him away in their own arms. As the late Sir Theodore Cook remarked at the time " It had its comic side ; but it was full of a deeper interest as well."

The next Marathon Races were won as follows :

1900, Paris (25 miles), Teato, France 2 hours 59 mins.

1904, St. Louis, U.S.A. (24 miles, 1,500 yards), T. J. Hicks, U.S.A., 3 hours 28 mins. 53 secs.

1906, Athens (26 miles, 385 yards), W. J. Sherring, Canada, 2 hours 51 mins. 23 $\frac{3}{4}$ secs.

Then came the most sensational Marathon Race from Windsor Castle to Shepherd's Bush, London, in connection with the fourth Olympiad, and the 2,000 years' old tragedy of Pheidipides was very nearly repeated. Prior to the Games the King of Italy himself had expressed to the Italian Olympic Committee his confidence in the prospects of Pietri Dorando, a slightly built Italian waiter, born at Carpi, Modena, some twenty-three years earlier. Dorando had never been beaten over distances in his own country and had finished first in a Marathon Race at Paris in 1905. He was, however, disqualified on account of some informality in his entry, a curious coincidence in view of what was to follow. The English press prophets of that period predicted that British runners would fill the first twelve places ; but, in point of fact, the only one who did anything like a proper preparation was Fred Lord, of Bradford, who finished fifteenth.

The Marathon Race

117

Marathon Day, 1908, was one of almost tropical heat, and the dust from the untarred roads was stifling. When the field of fifty-six runners lined up to face Lord Desborough, acting as starter, Johnny Hayes, U.S.A., was in the third, and Dorando, Italy, and C. Hefferon, South Africa, in the fourth row. H.R.H. the Princess of Wales gave the signal, and Lord Desborough fired the pistol. Two Englishmen, Clarke and Barnes, headed the field, followed by Burn and the Indian, Tom Longboat, both of Canada, and Pietri Dorando. At Barnespool Bridge, Eton, T. Jack, of the United Kingdom, had assumed the lead and the first mile had been covered in the absurdly fast time of 5 mins. 1 $\frac{1}{2}$ secs. At five miles, where I think I am right in saying that that great journalist, Fred Hatton of *The Athletic News*, who could not get a seat in the Press car, was waiting with a bicycle to act as attendant to Lord, Jack stopped for rest and refreshment, and his fellow Englishmen, Price and Lord, took the lead, with Hefferon and Dorando behind them. Hayes as yet was nowhere in sight. The distance had been covered in 27 mins. 1 sec., and at ten miles (56 mins. 53 secs.) and at eleven miles (1 hour 2 mins. 44 secs.), Price and Lord were still in the lead.

Meanwhile the first mad chase had scattered many fainting forms along the dusty roads, lined everywhere with cheering spectators, while others still struggled on foot-sore, dirty, and sweat-drenched. At about the half distance Lord collapsed into a bed of nettles with feet so skinned by leather shoes that they must have caused him agony. He had departed from the schedule Harry Andrews had planned for him and in trying to race Price up Pinder Hill had brought about his own downfall. Hefferon was then at Price's shoulder and stayed there until he took the lead at fifteen miles (1 $\frac{1}{28}$ / 22), where Lord had again caught up and Dorando was lying fourth. Longboat, the Canadian Indian, in third place, was about "all in" and kept appealing to his attendant to let him have the bottle of champagne, the neck of which protruded from the cyclist's pocket, and I fancy he got it in the end, for at seventeen miles he had dropped to a walk and Dorando soon passed him.

Athletics of To-day

Hefferon, nearly a mile ahead, looked all over a winner, and at twenty-four miles (2/33/28) was still leading. But at Wormwood Scrubbs, where the prison warders lined the walls to watch the race, a drink was handed to the South African, while it is said that another enthusiastic spectator drenched him with a bucket of water, and there is yet another rumour that he was given a strong stimulant. The truth of these tales will never be known, but from that point Hefferon began to peter out. He had run his twenty-second mile in 8 mins. 22 secs., with Dorando coming up and showing 7 mins. 58 secs. over the same section of the course. The Italian was catching up fast, and Hayes was perhaps a mile behind him, with Welton and Forshaw, the other Americans, not far away. Just before Wormwood Scrubbs both Dorando and Hayes passed the South African, and with twenty-four miles covered Dorando made the fatal mistake of trying to run clean away from the American.

At the Stadium the late Queen Alexandra and nearly 100,000 spectators, the largest number that has ever attended an athletic meeting in England, awaited the arrival of the runners. Dorando reached the cinder path so nearly unconscious that he turned to his right instead of to the left. His mistake was corrected, but he collapsed immediately. Doctors and attendants rushed to him, but he was not removed from the track, for every one felt that he should not be deprived of the laurels he had so nearly won. And so he was allowed to get up and stagger on for another fifty yards, when he collapsed again, but again he was helped up, only to fall once more and be picked up and almost carried past the winning post. His time was 2 hours 54 mins. 46½ secs., and half a minute after he had breasted the tape Hayes appeared and completed the course in 2 hours 55 mins. 18 secs., Hefferon finishing next in 2 hours 56 mins. 6 secs.

Not unnaturally both men lodged protests, and Dorando was disqualified on the grounds that he had received help. The Queen, however, much affected by the sight she had witnessed, presented Dorando with a gold cup to commemorate his extra-

ordinary gameness. A medical examination showed that the Italian's heart had been displaced more than half-an-inch, and for two-and-a-half hours he lay at death's door, but the next morning he looked as fit as ever. An extraordinary picture of Dorando finishing his plucky effort is No. 3, Plate 15, but how little he suffered in the way of after effects may be judged from No. 5, Plate 15, which shows him as his present, fat, well-seeming self at forty-four years of age.

During the next few years an epidemic of Marathon and "near Marathon" races swept over the world from Madison Square Gardens in New York to the banks of the Nile. Three important races were held in New York. In two of them Dorando beat Hayes and in the third was conquered by Longboat. Afterwards all three of them were beaten by St. Yves, a stoutly-built, short, and slightly bandy-legged French runner, with the heart of a lion, who, like Dorando, was a waiter by occupation. They in their turn all met Alfred Shrubbs and were beaten by him up to twenty miles, although Longboat beat him over the Marathon run, Shrubbs becoming sick and collapsing in the twenty-third mile after leading by a mile most of the way. Shrubbs and the "experts" say that he was running beyond his distance when he attempted Marathon races, but Harry Andrews, who had much to do with the making of Shrubbs, holds that the great little man would have been a marvel at the long journey if he had turned his attention to it earlier in life.

The Olympic Marathon Race at Stockholm in 1912 was a triumph for South Africa and America, for although the Dominion placed K. K. McArthur, a big, up-standing runner, first, and little C. W. Gitsham, second, the United States, out of twelve men who started, placed ten in the first eighteen, G. Strobino, a hitherto unheard of runner from Peterson, New Jersey, being third, and A. Sockalexis, a Greco-American, coming fourth. On this occasion McArthur was nearly robbed of his victory by an enthusiastic, but foolish, spectator, who threw over his shoulders a heavy wreath of evergreens as he entered the stadium; and the day after the race

Athletics of To-day

Lazaro, of Portugal, died from the exhaustion of the contest.

The credit for the development of British Marathon men, who are now very nearly as good as any the rest of the world can produce, belongs entirely to the enterprise of the Polytechnic Harriers and the generosity of the proprietors of *Sporting Life*, who in 1909 presented a five hundred guinea challenge trophy for an annual race from Windsor Castle to Stamford Bridge Ground, London. In that race many of the world's great Marathon men have competed, and it has also brought honour to all that has been and is best of our British talent. The first name inscribed upon the trophy is that of H. F. Barrett, Polytechnic Harriers. He recorded 2 hours 42 mins. 31 secs., and was followed home by Fred Lord, Wibsey Park A.C., who learned a hard lesson in the previous year, and H. Green, of the Harroddian A.C. In the following year Green won and in 1912 was again third. Special mention is made of Green, because in the next year he reached world-beating form, and at Stamford Bridge on May 12th, 1913, smashed up every record from twenty-one miles in 2 hours 2 mins. 42 secs. to twenty-six miles in 2 hours 36 mins. 52½ secs.

Above ten miles the distances recognised officially for world's records go up in units of five miles, and it is interesting to note that all are held by British runners as follows :

Fifteen miles, 1 hour 20 mins. 4¾ secs., F. Appleby, 21 /7 /02.

Twenty miles, 1 hour 51 mins. 54 secs., G. Crossland, 22 /9 /94.

Twenty-five miles, 2 hours 29 mins. 29¾ secs., H. Green, 12 /5 /13.

The one hour record of 11 miles 1,636 yards was made by Paavo Nurmi, Finland, at Berlin, on October 7th, 1928, but the two hours record of 20 miles 952 yards has stood to the credit of Green since that memorable day in May, 1913.

Speaking in general, international Marathon records are of little comparative value, on account of variation in courses, environment, atmospheric and climatic conditions, prevailing at different times and in different countries. The fastest time

ever returned for the full Marathon journey is that of J. C. Mills, of Sydney Mines, Nova Scotia, who returned 2 hours 25 mins. 40 $\frac{3}{4}$ secs. in the Boston Marathon of 1926, beating Albin Stenroos, Olympic victor of 1924, by nearly four minutes. The best Olympic time is that of Hannes Kolehmainen, Finland, who, in 1920, covered the Marathon course at Antwerp in 2 hours 32 mins. 35 $\frac{1}{2}$ secs. In Plate 15, No. 4 is a portrait of Kolehmainen, whose road work may also be seen in No. 1, Plate 12, while No. 6, Plate 15, is of Albin Stenroos.

It is the standardising of the course from Windsor Castle to Stamford Bridge, however, that gives us the best chance of assessing the improvement that has taken place in Marathon running. In 1909, Barrett made the journey in 2 hours 42 mins. 31 secs., as stated above, but in 1928, H. Payne, an old cross-country runner (No. 1, Plate 15), made a new record for this particular course of 2 hours 34 mins. 34 secs. Since then, Corporal S. Ferris, R.A.F. (No. 2, Plate 15) has won the Liverpool "Civic Week" Marathon in 2 hours 33 mins., but the race, although of the standard distance, was run over a different route and in a different part of the country.

In 1920 and 1924 the performances of the young Boston farmer, A. R. Mills, who won the Polytechnic event in 1920, 1921, and 1922, finishing second in 1923 and third in 1924, D. McLeod-Wright, Scotland, 1st, 1924, and S. Ferris, who made his *début* in reaching second place to the Scotsman, gave Great Britain every right to hope for Olympic victories at Antwerp and Paris, for the qualities of Kolehmainen and Stenroos were not well known beforehand, but Mills wore himself out with too much racing before the 1920 Games, and at Paris neither he nor Wright finished the course, the latter having trouble with his foot bandages. Ferris, although still lacking in experience, was placed fifth, immediately ahead of M. Plaza, a bigly built Chilean, and A. El Ouafi, a diminutive French-Arab, who had seen service in Morocco against the forces of Abd-el-Krim, thus improving his distance work in a very hard school as a despatch runner to the French Army. Ferris's time was 2 hours 52 mins. 26 secs., that of Plaza,

Athletics of To-day

2 hours, 52 mins. 54 secs. and of El Ouafi, 2 hours 54 mins. 19½ secs.

Why we should have imagined that his rivals would not improve equally with Ferris, who made great progress in the period of four years, I cannot tell; but in England in 1928 there was shown a good deal of confidence in the ability of Ferris to win at Amsterdam. H. Payne had proved himself quite as good as Ferris, and Ernest Harper, the old ten miles and cross-country champion, had trained on nicely. Joie Ray, America, like Kolehmainen before him, was looking for fresh worlds to conquer, and Canada had two real good men in J. C. Mills and Cliff Bricker. What none of us reckoned with was the fresh generation of Finns, the new prowess of Japan, and the vastly improved form of the men that Ferris had beaten four years earlier.

To make matters worse for Great Britain, the A.A.A. decided not to recognise the Polytechnic Marathon as the English Championship, as had been done in the previous years, and the Regent Street Club refused to abandon its fixture. There was also the Northern Marathon, and so we had the absurd position of three gruelling Marathon races being held within the space of three months before the Games, and some of our best men, but not Ferris, took part in all of them. One cannot wonder, therefore, that they could not reproduce their best form at Amsterdam. Had Payne refrained from competing in the A.A.A. Championship, which he won in July, I think he might have been very near to victory in Holland, but he had had two tremendous struggles within three months and the edge was off his keenness.

The 1928 Olympic course was a fairly easy one, run over level country, though the roads were rough in parts, but this did not bother El Ouafi, who entered the contest inured to hardships, heat, and rough going. The Englishmen on the other hand had a good deal of trouble with their feet. With eighteen miles covered the two Japanese, K. Yamada and H. Isuda, were well to the fore followed by M. B. Martellien, Finland, "Chesty" Joie Ray, America, and Ernest Harper,

Great Britain ; Ferris lay seventh, and McLeod-Wright ninth. Nearing the stadium, Yamada was still leading, but Isuda had given place to Ray, El Ouafi, and Martellien, while Ferris was moving up place by place.

When the trumpets rang out from the Marathon Porte to announce the approach of the victor, the Americans had their community yell all ready to greet Joie Ray, the British were half hopeful that Ferris might yet do the trick, and the Japanese spectators sat silent but expectant. It was El Ouafi who swung in through the great gates and flung up his arms in acknowledgment of the volley after volley of cheering that came spontaneously from thousands upon thousands of throats. Before he had traversed 200 yards of the arena, Plaza appeared, followed by Martellien, Yamada, Ray, Isuda, Ferris, and H. Wood, who had won the English Northern Marathon in the spring. El Ouafi's time of 2 hours 32 mins. 57 secs. was less than a quarter of a minute outside the Olympic best, and he finished amazingly fit.

The descriptions I have written of various Marathon Races should give the reader a good idea of how the distance should be run. For example, Hayes finished when Dorando collapsed, because the American was a fine judge of pace and would not allow himself to depart from his schedule. Lord failed because he was tempted to try to run Price off his feet up Pinder Hill. The proper procedure is to start the race quietly and at moderate speed, so that you may establish full control over your muscles and nervous system. 2. Keep the brain occupied by observing what is going on about you ; this lessens the nervous strain of the contest. Remember that you have plenty of time to pass your opponents ; 3. do not try to get ahead by sudden bursts of speed. 4. Run to schedule and eat and drink only according to your coach's orders or your own preconceived plan. Small, light men, like Dorando, Hayes, Gitsham, Kolehmainen, El Ouafi, and Ferris, usually make the best Marathon runners, but the big, tall men, to which class belong McArthur and Plaza, and the short thick-set type, such as Mills and Stenroos, have all had their successes.

TRAINING

Training for the Marathon distance is a long and serious business. I have collated the opinions of the world's greatest professional coaches upon the question of the time necessary, and they read :

The late Michael Murphy (American Olympic Coach), eight to ten weeks.

The late S. A. Mussabini (Coach to the Polytechnic Harriers), twelve weeks.

Alec Nelson (British Olympic Coach, 1912, and C.U.A.C. Coach), sixteen weeks.

E. Hjertberg (Swedish and Dutch Olympic Coach), twenty weeks.

In my opinion Hjertberg is more nearly right than Murphy, but the great Marathon men themselves seldom go out of training.

Something of the exacting nature of a Marathon runner's preparation may be understood from an examination of the training methods of such men as Sam Ferris and "Treadmill" Cliff Bricker of Canada, who has won two out of four Marathons, and, including these, has finished first in thirty-six races, ranging from 1 mile to 26 miles 385 yards.

Ferris is a non-smoker, but does not favour dieting, and holds definite views as to the value of massage, sun-baths, and time schedules. Since 1924 he has had only one rest period which lasted for three weeks. In the first week of training his walks vary from ten to twenty miles ; in the second week he runs similar distances ; at the end of a month he is speeding up his pace at ten miles on the cinder path ; in the sixth week he runs ten miles on Wednesday and twenty-four on Saturday. Three times during the seventh week he travels fast on the track at eight to twelve miles and finishes off his training to the end of the eighth week with long strolls.

Bricker neither drinks, smokes, nor favours any form of amusement, and his training varies less than that of Ferris. He runs strictly to the watch in competition and never worries

The Marathon Race

125

about either the pace or position of his opponents since he himself can run any mile in twenty-six miles in 6 mins. dead. He also commenced running in 1924, and since then has never broken training. Each Saturday afternoon he leaves Galt for a ten mile run, but doubles the distance in Marathon training. Sunday at 6 a.m., without breakfast, he starts on a thirty mile walk. The first food he takes that day is a bar of chocolate three or four miles from the end, to take the edge off his hunger, prior to the good meal awaiting him at home. After that meal he sleeps until supper time. Monday he rests, and on Tuesday runs five miles at Marathon pace. Wednesday brings a ten mile walk. Thursday he just skips and punches the bag. Friday night he rests in preparation for Saturday's run and Sunday's long walk. He does not diet, but eats meat only once a day, at noon, and will not touch either tea or coffee.

On the whole I should say that small, light-bodied men are the best performers at the Marathon distance, but, whatever a man's build may be, the predominant factors in his make-up must be will-power allied to patience, concentration, dogged determination, and the peculiar temperament that takes pleasure in long and arduous training.

CHAPTER IX

THE LONG DISTANCES—30 TO 100 MILES

THE world's history and the archives of pedestrianism are rich in romantic legends of prodigious feats accomplished by the long distance runners of ancient times.

In the Middle Ages the couriers maintained by monarchs and municipalities were the recognized distance running champions, the Basque country, Britain, Italy, Tartary, and Turkey being reputed to have produced the best men. The Peichs, or Persian couriers, of the Turkish Sultans, it is said, were well able to run from Constantinople to Adrianople and back, a distance of about 220 miles, in two days and two nights, during which time they carried silver beads in their mouths to counteract thirst. I have myself known *dâk* runners and other natives in Africa and India to perform some extraordinary feats of sustained speed and endurance, while the French-Arab, El Ouafi, and the Japanese Marathon men, Yamada and Isuda, have recently shown us what the coloured races can do, but even so, and in view of well authenticated records which will be quoted presently, the performances of the Peichs would appear to belong rather to the nature of fiction than fact.

In the post-Restoration period, as we have seen in the opening pages of this book, it was the running footmen of the English nobility who gained notoriety in the phase of athletics under consideration.

Half-way through the eighteenth century we come across records of a man who may be said to have been the long distance champion of the world for nearly five and twenty years. This was Foster Powell, born at Horsforth, near Leeds, in 1734, and afterwards clerk to a solicitor of New Inn, London.

His athletic history is in some respects similar to that of A. F. H. Newton, whose deeds will be dealt with later, for neither of them turned his attention to athletic competition until over thirty years of age, and both performed great feats on the Bath Road. Foster first gained fame by running 50 miles on the Bath Road in 7 hours, his first 10 miles being covered in under the hour. Then followed a period of exhibition running on the Continent.

At thirty-nine years of age, with the inducement of a heavy wager, he made the journey from London to York and back on foot, covering a distance of 402 miles in 5 days 18 hours, thus winning his wager by a margin of 6 hours. At forty-three years of age he went from London to Canterbury and back (112 miles) in under 24 hours. At fifty-seven years of age he again attempted the London to York and back in 6 days and won his wager ; on the eve of his sixtieth birthday he amazed all the world by again undertaking the great journey on foot, and, what is more, he beat his own previous best efforts by doing the 402 miles in 5 days 15¼ hours. The strain imposed upon a man of Foster Powell's age was tremendous, and shortly afterwards he died. The reader may note that the remains of this great pedestrian are buried in the east corner of St. Paul's churchyard.

In later times long distance running seems to have enjoyed great popularity during the early eighties of the last century, when indoor, as well as road, races and exhibitions of running appear to have found favour. At the old Agricultural Hall, Islington, London, W. C. Davis established records from 51 miles in 6 hours 57 mins. 50 secs., to 81 miles in 12 hours, and at the same period J. Sanders was achieving lasting fame in America. In New York on February 22nd, 1882, these men covered 95 miles in 16 hours 27 mins. 20 secs., 100 miles in 17 hours 36 mins. 14 secs., and 120 miles in 22 hours 47 mins. 23 secs., a truly amazing feat of endurance and sustained speed.

The year 1884 found three great distance men at work in England. On November 29th A. W. Sinclair, at the Aquarium,

Athletics of To-day

Westminster (I think) put up a series of records from 82 miles in 12 hours 49 mins. 50 secs. to 90 miles in 15 hours. J. A. Squires, who in April, 1885, at Balham ran 35 miles in 4 hours 4 mins. 50 secs., and a month later did 27 miles in 2 hours 54 mins. 26 secs. to 30 miles in 3 hours 17 mins. 36½ secs., was training on, and that grand little veteran, J. E. Fowler-Dixon, still happily with us, had reached the zenith of his fame.

Mr. Dixon, seen running as a veteran in Picture 4, Plate 12, was a short, very lightly built athlete in those days, and his method of training caused more than one old London jehu to scratch his head. Road work was what Mr. Dixon wanted and, since his occupation kept him in London and busy all day, he chose the Outer Circle of Regent's Park for his running track. It was his custom to hire a hansom cab, strip, put his clothing inside and order the jehu to drive hard round the Circle until told to stop, while Mr. Dixon himself trotted along behind his novel pacemaker. His preparation finished, he repaired to Birmingham, and on December 29th, 1884, made new records from 37 to 46 miles, of which his 40 miles record of 4 hours 46 mins. 54 secs. still stands uneclipsed. He also ran 46 miles in 5 hours 43 mins. 13 secs.

The sceptics of London, however, would not believe that such times had ever been returned, and so Mr. Dixon determined to do it all over again, and at Balham, on April 11th, 1885, he set up a series of fresh figures from 43 miles in 5 hours 17 mins. 18 secs., to 50 miles in 6 hours 18 mins. 26½ secs.

It would be incorrect even now to say that Mr. Dixon has retired from the track. For many years it has been his custom to "go a mile" to celebrate his birthday, and at seventy-one years of age he proved himself capable of running the distance in 7 mins. 6¼ secs., and on September 1st, 1928, he was one of the seventeen competitors entered for the Centurions' 3 Miles Walk and covered the first mile in 12 mins. 54 secs., a marvellous performance for a man who was to attain his seventy-eighth birthday two days later.

The world's records made by J. E. Fowler-Dixon in the

early eighties were destined to stand for the best part of thirty years. But early in 1913 E. W. Lloyd of the Herne Hill Harriers went into serious training for the purpose of breaking them, and at Stamford Bridge on May 12th produced a new set of figures ranging from 41 miles in 4 hours 58 mins. 9 secs. to 50 miles in 6 hours 13 mins. 58 secs.

No long distance runner of such a calibre as these two men was ever heard of until rumours began to emanate from Natal of an amazing South African farmer named Arthur Newton, who may be seen in Picture No. 5, Plate 12. As a lad at Bedford School, Newton had been wont to think nothing of an afternoon spin of 15 or 20 miles, but to the best of my belief he never entered his name for a single athletic contest, or attempted any record-breaking feats, until he was nearing forty years of age. But, when he did start, the long standing records came tumbling down like leaves in autumn.

I met him first in the offices of the *News of the World*, Joe Binks of that paper being responsible for arranging all Newton's extraordinary runs in England. I found Newton a tall, sparely built man, who looked rather weary and worn, and it was hard to believe that he had already during July, 1923, run 50 miles on rough South African roads in 5 hours 53 mins. 5 secs. What puzzled me still more was why South Africa had not entered him to represent the Dominion in the Marathon Race at the Olympic Games.

Arthur Newton's records from 50 miles on rough South African roads in 1923, when he was thirty-nine years of age, to 100 miles on the Bath-London road in 1928, when he was approaching forty-five years of age, are given here :

Records in South Africa on Rough, Hilly Roads.

1923—50 miles, 5 hours 53 mins. 5 secs.

1925—54 miles 1,102 yards (Maritzburg to Durban), 6 hours 14 mins. 30 secs.

En route—30 miles, 3 hours 18 mins. 0 secs.

40	„	4 hours 30 mins. 20 secs.	} new records.
50	„	5 hours 44 mins. 50 secs.	

Athletics of To-day

1927—60 miles, 7 hours 33 mins. 55 secs.—new record.

En route—40 miles, 4 hours 46 mins. 30 secs.

45 „ 5 hours 30 mins. 0 secs.

50 „ 6 hours 12 mins. 0 secs.

1927—100 miles, 14 hours 43 mins. 0 secs.—new record.

En route—90 miles, 13 hours 3 mins. 0 secs.—new record.

1927—Won the Marathon Race at Bulawayo in 2 hours 52 mins. 8½ secs. on June 19th, 1927. The course was officially measured as 26 miles 400 yards.

Records in England on the Roads.

London to Brighton (52 miles 200 yards)—5 hours 53 mins. 43 secs. on November 13th, 1924, his time for 30 miles being 3 hours 9 mins. 55 secs.—record.

Previously on October 4th, 1924, he broke the London to Brighton record by returning 6 hours 11 mins. 4½ secs. On this occasion his time for 30 miles was 3 hours 11 mins. 43 secs., and was a record.

On January 7th, 1927, he ran 100 miles from Box (6 miles from Bath) to Hyde Park Corner, London, in 14 hours 22 mins. 10 secs.

In the course of his London to Brighton run in March, 1925, he beat the old professional record by more than 40 minutes and the amateur record by over an hour. At Crawley, *en route*, he was 3 mins. inside Squire's 30 miles record, already mentioned, while Hickstead (40 miles 300 yards) was passed in 4 hours 36 mins.—that was 20 mins. 34 secs. better than J. E. Fowler-Dixon's world's record for 40 miles on the track. At 50 miles he was no less than 35 mins. ahead of E. W. Lloyd's amateur track record and 17 mins. inside G. Cartwright's professional record.

On January 7th, 1928, Newton beat his own 100 miles record by 20 mins. 50 secs. And yet he was a sick man that day; a high south-westerly wind blew against his right side all the way; it was terribly cold, with rain falling at intervals; while the roads were heavy, and time and again he was forced to wade through flood water. That race was started at 2 a.m.,

and at intervals Newton drank almost boiling tea, and for breakfast he had hot minced beef. At Reading, where he was suffering severely from cramp, he had recourse to his own "magic" drink, which consists of lemonade, sugar, and salt. At Colnbrook he put on speed and was still striding a steady 180 steps to the minute. At Hyde Park Corner thousands of people had been waiting for hours, and the scenes of enthusiasm which signalized the South African runner's arrival were truly remarkable.

On all his runs Newton impressed me as being the most perfect human long-distance running machine that has ever been known. His action suggested that he could run for ever. In his early years he progressed with a short, shuffling stride, running quite flat-footed and with his feet never passing higher than 6 inches above the ground. His arm carriage was very loose and low. That was in 1924. When we saw him again in 1927-28 he had shortened his running stride to 3 ft. 7 ins., and his feet did not rise more than a couple of inches above the ground as he ran, but he was running far back on the sole of the foot and keeping the heels more off the road (see No. 5, Plate 12).

His ideas on training for long distances were revolutionary, for he worked always at distances, and even coming over on the boat from South Africa used to run 20 miles on deck at 2 a.m. to keep fit. He smoked regularly and would enjoy a cigar while walking to the training grounds in England, and even after a big race would at once put on his pipe. Before one of his Brighton races he rose at 4 a.m. and had a light breakfast of fried eggs and bread and butter. During a race he never touched solid food, but took plenty of his special drink. This drink he devised to tide him over bad times. It is made by stirring six teaspoonfuls of sugar and half a teaspoonful of salt into half a pint of lemonade. Newton's theory is that this drink is the best thirst quencher and that the sugar generates internal warmth, while the salt counteracts cramp.

CHAPTER X

THE HIGH HURDLES—120 YARDS AND 110 METRES

THERE were hurdle races at the tutors' and dames' houses at Eton College as long ago as 1837, and that is the earliest reference to competition in this kind of athletic sport that I have been able to find, but in *Bell's Life* of 1853 mention is made of a match between two amateurs, one of the events included being a race with jumps over 50 hurdles each 3 ft. 6 ins. high. By that year, however, most of the schools that had started athletic sports meetings practised hurdle racing.

The first authentic records of a hurdles time are supplied by A. W. T. Daniel, C.U.A.C. He won the first Oxford and Cambridge 120 yards High Hurdles event, 1864, in $17\frac{1}{4}$ secs., and was succeeded by T. Milvain, C.U.A.C. He won the Inter-University event, 1865, in 19 secs., and the first English Championship of 1866 in $17\frac{3}{4}$ secs.

In America the first National Championship was won by George Hitchcock, N.Y.A.C., in 19 secs. and that of the Inter-Collegiate A.A.A.A., founded also in 1876, by W. H. Wakeman, Yale, in $18\frac{1}{4}$ secs. First Championships were won in Norway, 1896, by C. O. Olsen, $18\frac{3}{8}$ secs., and in Sweden, 1897, by A. Svensson, $17\frac{1}{8}$ secs. The first title at the English Public Schools Championships was won in 1896 by W. N. Pilkington, Clifton, in $17\frac{3}{8}$ secs.

The evolution of modern high hurdling has been a clear case of applied mechanics in relation to sport, from the earliest championship times to the year 1920, in which Earl Thomson, a hefty young Canadian, who stood 6 ft. 3 ins. in height and weighed $13\frac{1}{4}$ stone, said what is still the last word in hurdling speed, by setting up a world's 120 yards record of $14\frac{3}{8}$ secs.

The High Hurdles

133

The problem has been to find a means whereby a man may run 120 yards over 10 flights of 3 ft. 6 ins. hurdles, with 10 yards distance between each flight, in the shortest space of time. In the solution of the problem an improvement of between 4 and 5 secs., or approximately 45 yards in 120 yards, has been brought about.

At first men merely ran the distance, jumping over each hurdle in turn and landing with both feet together, so that there was almost a dead stop in the run after each jump. Next came a "sail-over" effect with body almost upright, front leg tucked up, and rear leg trailing (see No. 4, Plate 19, K. Powell and R. Elmslie). It was quicker because it allowed the athlete to land on one foot. But still a lot of time was lost while the body was sailing over the hurdle.

Next it was discovered that a faster time could be achieved if a man took seven or eight strides to cover the fifteen yards up to the first flight, going over on the eighth or ninth, and, thereafter, taking three strides to cover the ten yards between flights. Even with this improvement in method such fine hurdlers as E. S. Garnier, O.U.A.C., H. K. Upcher, O.U.A.C., C. L. Lockton, L.A.C., and C. F. Daft, all equal to showing about $12\frac{3}{4}$ secs. for 120 yards on the flat, could produce nothing better than 16 to $16\frac{3}{4}$ secs. over hurdles, so that they were taking roughly 4 secs. to negotiate the 10 flights, as compared with Thomson's subsequent 2 to $2\frac{1}{2}$ secs., since the Canadian never showed anything like even time on the flat.

The early sixties brought to light a young Oxonian with a great natural gift for the game and the right type of brain to study its technique. This was A. C. M. Croome, who shattered the illusion that graceful hurdling was good hurdling, his theory being based upon the assumption, perhaps, that what is pretty is very often not practical. What Mr. Croome was looking for was something which would put a punch into hurdling without destroying rhythm. He stated that "the men who look nice when running over sticks take their fences in the wrong way," and he gave the modern generation the power for its ruthless onrush.

Another axiom of the great Oxonian was that "only in the 120 yards high hurdles do we find eleven winning posts in one race." He has laid it down also that the hurdler needs a higher average of intelligence than most other types of athlete. In support of this it may be stated that in the persons of the four starters in the 1886 Oxford and Cambridge race which Croome won in 16 $\frac{3}{4}$ secs., there were combined one Rowing, one Cricket, one Rugby, two Hammer Throwing, and four Hurdling Blues, the presidents of both athletic clubs, two county cricketers, one champion figure skater, two holders of N.S.A. badges, two scratch golfers, four superb waltzers, one fellow of a most exclusive college, one University prizeman, four holders of scholarships or exhibitions, while the names of the quartette had appeared on seven occasions in some first class honours list.

Mr. Croome's new theory of hurdling was that in taking the fence the leading leg should be kept practically straight, instead of being curled up, as shown in No. 4, Plate 19, in which the leading figure is the late Kenneth Powell, C.U.A.C., since this new action brought the seat of the athlete's shorts closer to the top rail of the hurdle, or, in other words, he did not have to lift his body so high as in the older method. Added to this, the straight-legger gets a margin of safety for his front foot, while the bent-legger, if he hits the hurdle with his knee or ankle-bone usually goes straight over. He decided also that the opposite arm should go forward with the leading leg (*i.e.*, right leg, left arm and *vice versa*) and that the body should be sharply dipped to meet the rising thigh of the leading leg, so that the front foot might the more quickly get to ground on the far side of the fence. In short, A. C. M. Croome evolved the modern very fast hurdling form, to which various points of greater perfection have been added in the years between to bring the record down to its present low figure.

The five-figure sketch, given on the next page, illustrates the style Croome used when he made his record of 15 $\frac{3}{4}$ secs.

A. C. Kraenzlein, *the* great American hurdler of the beginning of the present century, I have been told, saw Croome's style

The High Hurdles

135

and at once appreciated the advantage of, literally, taking the fences in one's stride, by means of a sort of straightforward, step-over action, but he did not use quite such a complete knee-lock as the Englishman favoured. Any way, Kraenzlein brought the record down to $15\frac{1}{2}$ secs.

The next point discovered was the value of rear hip flexibility ; this came to light through an accident to that part of Forrest Smithson's anatomy which left him with the ability to raise the knee of his rear leg level with the hip joint, as he went over his fences. This new action eliminated all body twist and enabled the hurdler to get to ground quickly and close to the hurdle. This American brought the world's record down to 15 secs. when he won the 1908 Olympic title. He propounded the theory that every hurdling action should be assessed according to its effect upon striding and sprinting



FIG. 10.

form, the corollary to that theorem being that a man makes better time on the ground than in the air. The "Smithson" landing, however, was a forced one and interrupted the smooth flow of the whole run. Also, a lot of men found difficulty in managing a full stride forward after landing.

There is, however, no disease without a remedy, and between 1910-15 the Americans, J. P. Nicholson (15 secs.), F. Kelly ($14\frac{1}{2}$ secs.), and R. Simpson ($14\frac{3}{8}$ secs.) perfected the body dip and improved the arm action. These three produced what is known as the "Three Right Angles" theory. These angles are that of the body with the thigh of the rear leg extending straight to the side, that of the rear leg thigh with its lower half leg which is bent directly backwards, and that of the lower leg with the foot which lies parallel with the thigh when the body is centralized over the hurdle.

The new arm action is shown in the picture of G. C. Weightman-Smith (South Africa and C.U.A.C.) (No. 2, Plate 20), who holds the World's and Olympic 110 metres High Hurdles record of $14\frac{3}{8}$ secs. The right arm goes forward with the left leg, *or vice versa*, and is snapped downward and slightly to the side to enable the athlete to claw down more quickly with the leading leg. The arm and leg action are fully emphasized in the picture of Weightman-Smith.

Back in the year 1911, when the three big American hurdlers were gradually drawing nearer to the light, Earl Thomson, a Canadian born, was sent to the local high school at Long Beach, California, for a course of higher education. It was there that he saw his very first athletic hurdle—and liked the look of it. A week later he had bought a track suit and was trying his luck with the rest. For two years he hurdled when he could and meanwhile was taking a keen interest in the doings of the great hurdling stars. He really began his career on a few words of advice dropped by Ben Ward, who was very nearly as good as Kelly, winner of the Olympic title, 1912, in $15\frac{1}{2}$ secs. At the World's Fair, San Francisco, 1915, Thomson represented the Los Angeles A.C. and had his first sight of Simpson. Then he went to the University of Southern California and got constant practice with Kelly, but never dreamed of beating the champion, and yet the first time they met in competition Thomson won and equalled the world's record of $14\frac{3}{8}$ secs.

Thomson was terribly strict with himself in his training, which he based on the late Michael Murphy's book. He would not even sleep crooked in bed for fear of cramping his muscles. He may have been absurdly particular, but the point is that he was willing to make any sacrifice to ensure success, and that is just what such a lot of "just-short-of-champions" will not do.

Honours came early to Thomson, but that did not satisfy him; he was chewing away at theories that might mean new world's records. He watched the best stylists at work, and he studied every picture of hurdling he could get hold of. He had already perfected his own double arm forward lift (see Plates

16 and 19), instead of letting only the arm opposite to the leading leg go forward. Next he started his hurdle clearance action with a high-pick-up of the front knee before letting the front foot go forward to clear the top of the fence, to make the step-over action more true in character. Finally he added the trick of picking the rear knee right up to the shoulder, as seen in the picture of Weightman-Smith, so that, as the body straightened up from the dip to the sprinting angle (see Fig. 3, Chapter II), the rear leg should be properly disposed for a full and complete stride forward.

A week before the Olympic hurdle race at Antwerp in 1920, Thomson pulled a muscle in the front of his leg. He got it patched up, but it went again in the first heat, and yet he qualified second to H.E. Barron, U.S.A., who equalled world's record. In the semi-final he got through in 15 secs. flat and in the final returned $14\frac{1}{2}$ secs for a world's record. On May 29th, 1920, at the I.A.A.A. Meet he set the world's 120 yards High Hurdles mark at $14\frac{2}{3}$ secs., and in 1921, at the first National Collegiate A.A. Championships, produced the same time, with some unofficial timekeepers returning him a fifth of a second faster.

Thomson reckoned to allow himself two or three weeks to get fit ; then he put in most of his training time working for form, running a quarter mile once a week and striding through 250 to 300 yards three or four times a week. He used to do a lot of jogging too, and never ran the full distance over ten flights more than once a week.

Hurdling progress, however, has not been confined entirely to America, although it was in that country that Thomson, the Canadian, built up his technique. Sweden has produced two really great hurdles in C. Christiernsson and Sven Pettersson, the latter credited with $14\frac{3}{4}$ secs., while H. Trossbach, who holds the German record of $14\frac{9}{10}$ secs., must be reckoned in the first flight. New Zealand gave us H. Wilson, a very good man who finished fourth in the 1920 Olympic final, while South Africa has been a power to reckon with ever since V. Duncker came over in 1908 and won the English Champion-

ship, and H. Jeppe won the Inter-University event for Oxford in 1920.

The cream of the South African hurdlers did not appear, however, until 1924. In that year S. J. M. Atkinson broke F. R. Gaby's long run of success and won the A.A.A. title in $15\frac{1}{16}$ secs. on a rough grass track. At Paris in his Olympic heat he reproduced the same time without unduly hurrying himself, but in the final D. C. Kinsey, U.S.A., held him all the way, with the Swedes, Christiernsson and Petterson, right up until two flights from home. Coming to the last flight, Atkinson was half a stride ahead, but he hit the hurdle hard, "pecked" on landing, but recovered and was only beaten an inch by the American in 15 secs. flat.

In 1925 G. C. Weightman-Smith arrived at Cambridge University from Natal. He had been hurdling since he was thirteen years old and had beaten 16 secs. while still in his "teens." His real discovery came about through an Oxford University team visiting South Africa in 1923 for a series of five matches, in three of which "Weiters," then only seventeen years of age, took part. In the first he made Trevis Huhn (Princeton, U.S.A., and Oxford) return $15\frac{1}{2}$ secs. for a narrow victory; in the second S. J. M. Atkinson, the South African Champion, just beat him in $15\frac{3}{4}$ secs.; and in the third he made Atkinson create a new South African record of 15 secs. to win. In each of the two latter races the crack American-Oxonian hurdler was beaten into third place, and yet Weightman-Smith was not included in the South African Olympic team which went to Paris in 1924. At home he had been overshadowed by Atkinson and Viljoen; at Cambridge it was the shadow of Lord Burghley which clouded his path for three long years, although in 1926 he twice achieved 15 secs. In June, 1927, he got inside "evens," and in March, 1928, set up a new Oxford and Cambridge sports record of $15\frac{1}{8}$ secs. A.A.A. and Olympic Championship honours were predicted for him in 1928, but he has been extraordinarily unlucky. At the English Championships of that year he was level with, if not a little ahead of Atkinson at the seventh flight, where he hit a

The High Hurdles

139

hurdle, missed a stride, and crashed into the eighth, Atkinson putting up a new British record of $14\frac{7}{10}$ secs.

At Amsterdam "Weiters" in his heat produced a new Olympic record of $14\frac{3}{4}$ secs. Despite his fall in the A.A.A. Championships a month before, it seemed certain that he must achieve Olympic honours, and would probably break world's record. But in hurdling nothing is more uncertain than the absolute stone-cold certainty. On the morning of the finals I ran across Weightman-Smith in Amsterdam, and somehow he did not look too bright. When he turned out for the great race in the afternoon he was obviously bothered about something. He had cause enough for worry, for he had drawn the very worst lane in a notoriously loose track. Apart from that I think the greatness of the occasion overawed him a little, while some subconscious sense must have brought back to his mind the disastrous fall at Stamford Bridge. Weightman-Smith was so evidently suffering from mental strain that he did not even bother to limber up to loosen his muscles.

The men went to their marks, three Americans, two South Africans, and one Englishman. The starter kept his field hanging such an unconscionable time that Gaby broke. At the next attempt the six went away together, but Weightman-Smith seemed to dwell, and J. Collier, U.S.A., showed ahead over the first flight, and with each flight increased his lead from Weightman-Smith, who was hurdling very high. At the half distance Collier looked all over a winner, but then his fellow American, S. Anderson, and the South African, S. J. M. Atkinson, came to the front, while L. Dye, U.S.A., passed Weightman-Smith, F. R. Gaby then being well in rear of the field. Anderson and Atkinson passed over the last hurdle absolutely level, but the South African was a shade ahead on landing and never faltered as he tore for the tape to beat the American by the barest inches in $14\frac{3}{4}$ secs., with Collier third, Dye fourth, Weightman-Smith fifth and Gaby last. Atkinson well deserved his win, both on his form and in compensation for his bad luck at Paris; but every one felt sorry for "Weiters," whose case was clearly one of mental strain and the ill-luck of

drawing a bad lane and of being overawed by the greatness of the final issue.

Towards the end of 1928 Cambridge discovered a very fine "rough" hurdler in the Shrewsbury Freshman, R. M. N. Tisdall, who hails from Ireland. In his trials he returned $15\frac{1}{2}$ secs. for the High Hurdles, and went within two-fifths of a second of British record in the Low Hurdles. He was then entirely without style, but, if he can be taught to step over his fences with a straight leg, I think he will prove, probably, the fastest hurdler Great Britain or any country has yet produced.

It is significant of the improvement that has taken place in High Hurdling during the last twenty years that at Amsterdam in 1928 only three out of the nine heat winners failed to equal or beat 15 secs., while two semi-finalists returned $14\frac{1}{2}$ secs., and the other $14\frac{3}{4}$ secs. for a new world's and Olympic record, and in thirteen races 15 secs., the world's and Olympic record in 1908, was beaten five times and equalled five times.

At the London Olympiad in 1908 only four men succeeded in beating 16 secs. by one-fifth of a second in the fourteen eliminating heats. The four semi-final heats were won in $15\frac{2}{8}$ secs. (tying the previous Olympic record), $15\frac{3}{8}$, $15\frac{1}{2}$ and $16\frac{1}{2}$ secs. All the finalists were Americans and Forrest Smithson won in the then world's and Olympic record time of 15 secs. flat.

In Great Britain, meanwhile, no sort of hurdle coaching was available in pre-War days. At the schools ten flights of hurdles were set up a week or so before the sports, and the boys just jumped them or took them in the old bent-leg style, of which, possibly, they had seen pictures. Some succeeded despite a bad style. Of these may be mentioned the late Kenneth Powell, Rugby and C.U.A.C., whose Oxford and Cambridge record of $15\frac{3}{4}$ secs. stood from 1907 until Lord Burghley, another brilliant Cambridge hurdler and a far better stylist, returned $15\frac{1}{2}$ secs. in 1926. There was also P. R. O'R. Phillips, Highgate and C.U.A.C.; in 1910 he set the Public Schools record at $16\frac{3}{4}$ secs. and in 1911 took the Inter-University event and the A.A.A. Championship, both in $16\frac{1}{2}$ secs. Phillips's Public Schools record stood until 1928, in which year G. Dyas,

The High Hurdles

141

Lancing, returned $16\frac{1}{10}$ secs. Yet other pre-War hurdlers like H. S. O. Ashington, C.U.A.C., and G. R. L. Anderson, O.U.A.C., hit upon, or were shown, the proper style. Anderson, who might have developed into the world's greatest hurdler, Ashington, and Powell all fell in the Great War.

Then there is the question of tracks. Apart from the cinder paths at Iffley Road, Oxford, Fenner's Ground, Cambridge, the Army Ground at Aldershot, and the Leeds University Ground at Weetwood, there is not a track fit to hurdle on in England, for Queen's Club will provide a meeting place for athletes no more, and the grass course at Stamford Bridge is a standing disgrace to the ground at which the English Championships are held.

Despite all disadvantages and discouragements, however, the post-War generation of athletes has produced some really great hurdlers, and the work of such famous old blues as Guy M. Butler, while a master at Lancing, whence came Dyas and a host more of first-class young athletes, is something for which the governing body should be truly thankful. Alec Nelson, the C.U.A.C. coach, is another first-class instructor.

At Eton, Lord Burghley was unheard of as an athlete. In his first year at Cambridge (1924), he ran second to J. D. S. Pendlebury, the high jumper, in $17\frac{3}{8}$ secs., but failed to qualify for the 'Varsity side. He thus had the peculiar distinction of representing Great Britain in the Olympic Games before he had gained his Blue. L. F. Partridge, C.U.A.C., who had hurdled for Great Britain at Antwerp, was also in the Paris team. Partridge was one of Alec Nelson's early post-War products, and what the great little C.U.A.C. coach did for Lord Burghley afterwards was nothing less than remarkable. Here was an athlete who had gone up to Cambridge showing somewhere about 18 secs. and whom F. R. Gaby beat in the English Native Championships by fifteen yards in $15\frac{7}{10}$ secs., but who had come on sufficiently in half a year to run third in a preliminary heat of the Olympic Games to S. J. M. Atkinson and S. Anderson. From 1925 to 1927 Lord Burghley held the Inter-University title, returning $15\frac{1}{8}$ secs. in his first year and $15\frac{1}{4}$ secs. the two subsequent years. In 1927 he equalled

Athletics of To-day

British record of $14\frac{1}{2}$ secs., but the English High Hurdles title has steadily eluded him.

That Lord Burghley owes much to Alec Nelson there is no doubt, but he owes even more to his own fighting spirit and his genius for patient perseverance. Many an hour he has spent practising over a couple of hurdles in his garden, but an accident in early life has impaired his high hurdling style a trifle, in that he is compelled to throw his leg across a bit instead of getting the full stride, step-over action. This circumstance has not, however, bothered him at the longer distance and over the lower fences.

F. R. Gaby, Polytechnic A.C., is something of a "wonder" athlete, for at thirty-three years of age he was still winning English Open Championships and equalling British record of $14\frac{1}{2}$ secs. I well remember him in the early days after the War, when I came home from East Africa and, with W. E. B. Henderson, used to put in an evening or two a week coaching the Polytechnic field events men and hurdlers in the Regent Street Gymnasium during the winter months.

Gaby was in France as an airman from 1914 to 1919 and had won several sprint races from 100 to 440 yards. He was tall and spare and somehow did not look like shaping as a really great sprinter, although he had acquired Mussabini's style to perfection. I think "Sam" saw him hurdling in the gym. one night; anyway, he took him in hand and created him as a hurdler. Gaby, of course, was a keen, painstaking, and intelligent pupil, and had he possessed a little more height and weight would have been a world-beater, but it takes all of twelve stone to make a world's record-breaker, and I should say Gaby tipped the scale at nearer ten stone. But, still, he put in an enormous amount of time at special exercises, studying form and training to schedule. In 1920-21 he won some big events, but fell at the last hurdle in the A.A.A. Championships. He gained the title in 1922 in $15\frac{3}{8}$ secs.; 1923, $15\frac{1}{2}$ secs.; 1925, $15\frac{1}{2}$ secs.; 1926, $15\frac{1}{10}$ secs.; and 1927, $14\frac{9}{10}$ secs., probably one of the finest collections of championships the world has ever seen.

In the early months of 1924 Sam Mussabini was very confident that Gaby would win the Olympic Championship, but there came a very bitter blow, the Government Department in which he was employed moving him to the North of England, where there were no proper training facilities and no Mussabini to advise and coach him. Every athlete knows what this must have meant to a first-class hurdler in training for a world's championship. The effect is, indeed, seen in the facts that Gaby lost his English title to Atkinson in $15\frac{1}{8}$ secs., and at the Games in Paris was beaten in the semi-final by Christiernson and Anderson in $15\frac{3}{8}$ secs. At Amsterdam he went through to the final, in which he was placed sixth, a fine performance for a man of thirty-three years of age. In that same year, moreover, his slowest time in his six biggest races was 15 secs. flat.

Now as to the actual technique of the event. The start must be made, of course, from the crouch position (see Fig. 1 and Nos. 1, 2 and 3 Plate 5, Chapter II), but the hurdler must rise to the true sprinting angle (see Fig. 3, page 52) more quickly than does the sprinter, since he has only some thirteen yards to run to the take-off for the first flight of hurdles, which is set up fifteen yards from the scratch-line. He must make a careful study of the approach, take-off, and landing. A novice will clear from 12 ft. to 14 ft. in going over the hurdle; the expert takes off 6 ft. in front of it and, using the correct step-over action, body dip, and claw-down of the front leg, will land no more than 3 ft. or 4 ft. beyond it.

Next comes the question of correct striding. Thomson always got into the crouch position with the right foot in front, so that in seven strides he came to his take-off for the first hurdle, which he cleared right leg leading. I never saw Bob Simpson at work, but Mr. T. E. Jones, Physical Director of the University of Wisconsin, tells us, in his excellent book, *Track and Field*, that Simpson crouched right foot forward, took eight strides to his take-off, and cleared the first hurdle left leg leading. Mr. Jones had an opportunity of measuring Simpson's actual strides, and the diagram given on the next page is based

Athletics of To-day

upon those measurements. The hurdler should always train on cinders, if possible, and should prepare charts of his striding from actual measurements taken on the track after each run over.

The composite picture (Plate 16) made up of six photographs of Earl Thomson taking a hurdle shows nearly the whole clearance action. The only fault is in the first figure, in that he should not have allowed his heel to touch the track. It will be seen that in rising to the hurdle Thomson increased his body lean, as he extended both hands forward, palms downwards. As the back leg was straightened and its foot left the ground with a strong push away, the lower part of the leading leg was swung forward with toes pointed upwards, the arms were shot out and the chest brought down towards the rising thigh, *with back relaxed, not arched* (Fig. 3). The full extension of the leading (right) leg (Fig. 4), brought the thigh in contact with the breast and the left hand out beyond the right foot; as the right arm swung to the right, the stomach was drawn in to give the leading leg additional knee room. No attempt had yet been made to draw up the rear leg. In Fig. 5 the leading leg is clawing down to the ground and the back knee is being snapped up to the height of the left shoulder. Note the vertical lift of the right arm to balance the lift of the left knee, and the maintained forward body lean. Fig. 6 shows the amazingly correct sprinting angle Thomson contrived to reach in his first stride after landing from hurdle clearance, and the way the arms are working in concert with the legs to maintain the high pick-up of

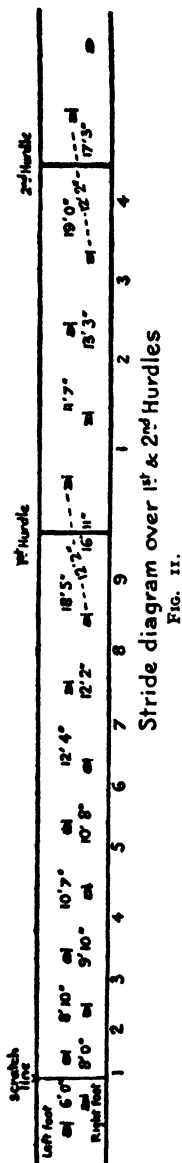



Pl. 17.

HURDLING EXERCISES.

- 1 Commencing position
- 2 Exercise 1, forward stretch.
- 3 Exercise 2, sideways bend.
- 4 Exercise 3, leg and arm stretch and body dip.

(A 11)

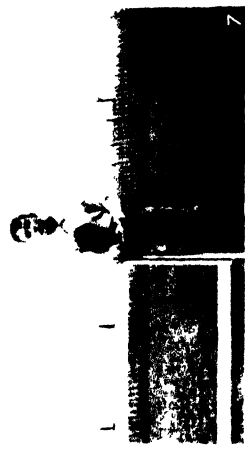

PLATE

PLATE 145A

HURDLING EXERCISES

5. Exercise 4, body fitting over hurdle with hands support. 6. Exercise 5, knee fit over hurdle. 7. Exercise 6, balance with thick pressing, against chest. 8. First position under bar. 9. Second position under bar. 10. Third position under bar.

the front knee and the forceful drive off the rear foot in a straight line from the ball of that foot right through the body.

Bear in mind these points :

(1) Let both arms, or the opposite arm, go forward, palms downwards, with the leading leg. Let the lift of the leading leg dominate the pick-up from the rear leg, or the hurdle will be jumped instead of taken in the stride.

(2) Shoot the body forward in the dip as it falls to meet the rising thigh.

(3) Do not hurry the pick-up of the back leg ; but, when it does rise, pick the knee up and out with plenty of snap.

(4) Get back to earth as fast as you can and as close to the hurdle as possible, especially if you are long-legged.

(5) As the front foot snaps down for the ground pick the rear knee right up to the shoulder and let the lower part of the rear leg fall into a straight down position for the next stride forward.

(6) Land on the ball of the foot and pitch forward into the true sprinting angle.

(7) Bring the back leg through and pick the knee up high as the first forward stride after landing begins.

(8) Make all your actions straight ahead.

(9) Keep the chin continuously in advance of the knee of the leading leg.

(10) Run a hurdle with the eyes fixed on the top rail of the next hurdle to be cleared. This will prevent you from hitting the hurdle you are clearing.

(11) Concentrate on your own hurdling and running in a race. A glance aside to see how others are faring will spoil your smoothness and most likely bring you down.

(12) Two hurdlers, working on form, will find it helpful to go over together, running slowly with 5 strides between flights, seeing who can come down to ground more quickly the other side of each hurdle.

N.B.—All these points are shown in the illustrations to this chapter.

Despite the fact that a first-rate hurdler will often beat a faster runner, speed is of primary importance to the hurdler. He must start the race at such speed as will allow him to come to his first take-off in good shape, but must be striving constantly to increase his speed over the first fifteen yards in combination with the ability to take off and effect a correct clearance at his acquired pace. This point is stressed because the best one can hope for through the body of the race is to maintain the speed built up in the sprint to the first flight and to find a bit more pace for the run-in. In running over the ten flights there is little hope of increasing one's speed; the hurdler's aim, in fact, should be to keep up, without losing balance or control, the speed at which he approached the first flight.

The standardized form between hurdles calls for three full strides, the obstacle being cleared on the fourth stride. Each of the three succeeding strides should increase in length. No matter how much you are pressed, do not hurry the pace over the last hurdle; a collected landing for the sprint to the tape is far more likely to bring you to victory than a scramble over the fence and an ill-balanced rush for the winning post. A long, swinging stride is needed between the hurdles. It should be changed to the proper sprint form directly the last hurdle is cleared. Run with the hands open until you concentrate on the sprint for the tape, then clench them tight.

Success in hurdling is at least seventy-five per cent form. The exercises shown in Plates 17 and 18 will go a long way towards the development of a proper style and the hurdler should devote half an hour a day to the practice of these exercises. In these plates No. 1, Plate 17, shows the commencing "spread" position, from which the two first exercises start. The leg one is accustomed to throw first over each fence is stretched straight out in front, with toes pointing upwards. The thigh of the other leg is at right angles to the body and the lower leg of the same limb at right angles to the thigh, with the foot at right angles to the lower leg.

Exercise 1 (No. 2, Plate 17.)—From the position shown in No. 1 stretch both hands forward, palms downward, until the

hands are beyond the feet ; at the same time press the head back, relax the back, and draw in the stomach. Force the body down to meet the thigh. Return to first position and repeat. Alternatively thrust forward the arm opposite to the stretched out leg, bend the opposite arm at the elbow, and draw back the elbow until the wrist is level with the hip as the body and the other arm go forward as shown in photograph.

Exercise 2.—Vary the position shown in No. 1 by placing the fingers of the right hand on the point of the left shoulder (or *vice versa*) and bend the body sideways until the right elbow touches the ground in the region of the right knee. (Read “ left ” for “ right ” if the right leg is stretched out in front.)

Exercise 3.—Place the heel of the usual leading leg on the top rail of a hurdle and repeat Exercise 1 ; after allowing the chin to touch the knee of the front leg, raise the body back to an upright position and repeat.

Exercise 4 (No. 5, Plate 18.)—Approach a fixed hurdle at a walk, throw the leading leg straight over. As you go forward grip the top rail of the hurdle with an over grip of the hands, lift the body from the ground and carry the rear leg over with the high knee-pick-up action and walk on, repeating at next and subsequent hurdles.

Exercise 5 (No. 6, Plate 18.)—Stand beside the hurdle with the lower leg of the limb near to it bent back at right angles to the thigh, side of leg resting on top rail of hurdle. Grasp the leg just above the ankle and lift to loosen hip joint, but keep the body perfectly upright.

Exercise 6 (No. 7, Plate 18.)—Balance on take-off foot, raise knee of usual leading leg, place arms round shin, and squeeze thigh against chest, at the same time rising on toes of grounded foot. Keep body upright. Release leg and complete the forward stride. Repeat with the other leg.

The number of times each exercise is repeated should be increased as the inevitable stiffness and soreness wear off.

Nos. 8, 9 and 10 show an admirable method of learning hurdle clearance. High jump standards are set up at either end of a swinging, or loose-topped, hurdle, and, to begin with,

the pegs are adjusted at just over the height of the hurdler's head when he is standing upright. He then runs over the hurdle and under a cross-bar which rests upon the pegs. In this way he acquires body dip (No. 8, Plate 18) ; leg stretch (No. 9) and a quick chop down and a high knee-pick-up (No. 10). As proficiency is gained the height of the cross-bar may be decreased, until there is no more than 2 ft. 3½ ins. between the top of the hurdle and the underside of the cross-bar, so that a six-foot man can go over a 3 ft. 6 ins. hurdle and under a cross-bar set at 5 ft. 9½ ins.

No. 3, Plate 19, affords an interesting comparison between the style of the boy taught under the bar, and the lack of style of a quite untutored friend.

No 1, Plate 20, portrays the perfect form of a 13 years old boy who began learning to hurdle under a bar when he was nine, and proves what can be accomplished by careful coaching when a boy is at the most impressionable age.

Nos. 1 and 2, Plate 19, are of Earl Thomson, holder of the world's 120 yards High Hurdles record of 14½ secs., and show the double-arm forward lift style in its most perfect form. His chin in front of leading knee, centralisation over hurdle, shoulders square to tape, and delayed back leg action should all be noted.

No. 2, Plate 20 (G. C. Weightman-Smith) shows the wonderful pick-up form of the great South African, but also reveals his fault of not getting the leading foot quickly enough back to earth.

No. 3, Plate 20 (F. R. Gaby) shows the correct chop down of the leading leg and the first stage of the action of bringing the knee of the rear leg up to shoulder height ; note the position of the left arm in readiness to punch forward in aid of the right leg forward swing in the first stride after landing. The one fault revealed is that Gaby is turning the left foot to the left, instead of keeping the toes pointing straight to the front on landing.

No. 4, Plate 19, shows that great hurdler, the late Kenneth Powell, practising with a fellow Blue, and reveals the wastage

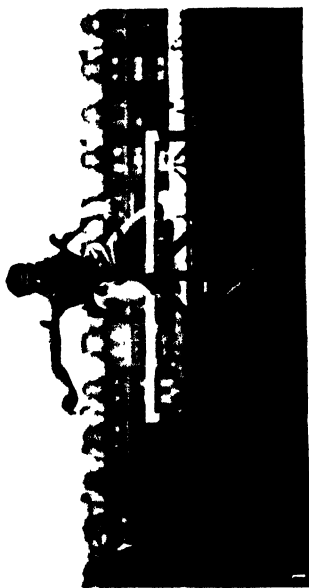

Sport and General 11, 148

THE HURDLES.

Pl. 10'

1. and 2. The World's Record holder, Earl Thomson, Canada. 3. Good style and back. Compare the style of the well-taught boy in white to that of the novice. 4. The old bent leg style.



St. Paul, Oregon (L. 14)



THE HIGH JUMPERS

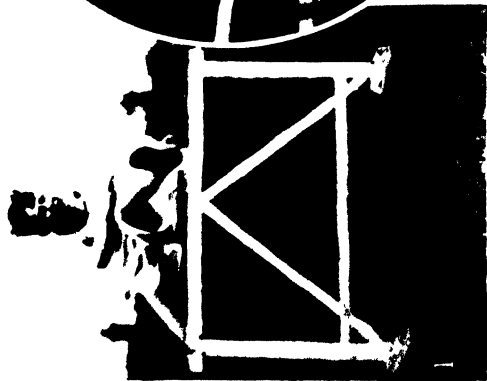

Pls. 20]

1. F. R. Webster, former Beds County Colts Record holder. The action is well balanced and the clearance margin economical. 2. G. C. Weightman-Smith, S. Africa, single arm action, showing knee pick up. 3. F. R. Gaby, former English Championship Record holder, showing rear leg action at landing. The left foot should not have been turned to the left.

of the old bent-leg style, which carried its exponents so much higher over the hurdle than does the new straight-leg, step-over action.

TRAINING

In the early stages of training, the hurdler should work in the gymnasium to build up his body muscles and do body-bending exercises to keep him supple. He may also begin to practise hurdling in the gymnasium during the winter months, but must go easy with this, or he will know what "shin splints" are like, for there is not the same give in a board floor that there is on a cinder track. Work hard in the preliminary training season to master and improve the proper form and go for jog-trot runs up to half a mile to get your legs into good condition. Work with the sprinters for speed in starting and on the flat, and with other hurdlers for speed over the sticks, but train alone when you are working for form. Get the start, approach run, take-off, and hurdling clearance and balance right by running from the scratch-line over two flights, as shown in striding diagram, Fig. 11, but do not try for Simpson's stride length until you are able to go at full speed. The striding of the individual will always vary with his physical make-up and condition.

For form and speed, work from 3 to 7 hurdles and do not run the full 10 flights more than once a week. Jog a quarter mile twice a week and run a fast 220-300 yards three times a week on the flat. Practise also over two flights with a 15 yards run-in, giving full concentration to changing from the swinging hurdling stride to sprint action and finishing speed.

Here is a suggested training schedule for the competition season, when one is really fit :

MONDAY—*Form, speed, and endurance.* Two hurdles half speed three times; six hurdles three-quarters speed twice.

TUESDAY—*Speed.* 150 yards seven-eighths speed.

WEDNESDAY—*Approach, finish, and speed.* Two hurdles

from start (approach and hurdling balance). Two hurdles to tape (balance and run-in). *Form*—Eight hurdles half speed.

THURSDAY—*Running balance*. 220 yards five-eighths speed, swinging stride as between hurdles for 205 yards, gathering your forces in last few yards, change to sprint action and sprint last 15 yards. *Alternative*—120 yards, sprinting first 15 yards, change to swinging hurdling stride at half speed for 90 yards, change back to sprint action and sprint final 15 yards. Rest 10 mins., and repeat.

FRIDAY—Rest.

SATURDAY—Full hurdle course, time trial with other hurdlers, or competition.

Before training or competition warm up very thoroughly. In training trot a lap, then do the spreading exercise. Before competition jog 100 yards, do spreading exercises, try a start over two hurdles twice.

CHAPTER XI

THE LOW HURDLES—220 YARDS, 400 METRES, 440 YARDS

THERE was a 200 yards hurdle race included at the first Oxford and Cambridge Sports Meeting in 1864 and won by E. Wynne-Finch, C.U.A.C., in $26\frac{3}{4}$ secs. I know that there were 10 flights of hurdles, but what height they stood I have not been able to ascertain, nor does it greatly matter, since the event was contested but once. In the files of *The Sporting Gazette* of 1874 I have found reference to plenty of 120 yards hurdle races, while various contests at 200, 250 and 300 yards over hurdles are recorded, with C. L. Lockton of Merchant Taylors' School usually figuring as the winner. In one of these contests at 200 yards over 12 flights he returned $26\frac{1}{2}$ secs. This is the only time I find recorded, and there is no mention of the height of the hurdles.

America took up furlong hurdle running (10 flights of 2 ft. 6 ins. hurdles) in 1887, when the first National Championship was won by A. F. Copland, Manhattan A.C., in 27 secs. In the following year the Inter-Collegiate title was founded and won by C. S. Mandel, Harvard, in $26\frac{1}{4}$ secs. By 1898, however, A. C. Kraenzlein, Pennsylvania, had brought the record down to $23\frac{3}{8}$ secs., a performance never equalled until 1913 when J. I. Wendell, Wesleyan University, won; R. I. Simpson, Missouri, again equalled the record in 1916, and C. R. Brookins, Iowa, reduced the world's best time to 23 secs. flat in 1924.

A 200 metres (218 yds. 2 ft. 2 ins.) hurdles race has been twice included in the Olympic programme, and won in 1900 by A. C. Kraenzlein, U.S.A., $25\frac{3}{8}$ secs., and in 1904 by H. L. Hillman, U.S.A., $24\frac{3}{8}$ secs.

Meantime hurdle races at odd distances survived for a long time in England, and Oswald Groenings made a British record of $36\frac{3}{4}$ secs. for 300 yards over 10 flights of 3 ft. hurdles as recently as 1907. I well remember him as a genial young giant, always game for a joke or a gamble. He once made a bet with me that I daren't start jumping in a high jump competition at 5 ft. 6 ins. I said that I'd take it on, if he'd do the same. We both brought the bar down twice, and each made it tremble at our third and final attempt, after which I think he beat me at a few inches higher.

Oxford and Cambridge did not again turn their attention to the Low Hurdles until 1922, in which year W. S. Bristowe, C.U.A.C., won in $26\frac{1}{2}$ secs. In the next year the American Rhodes Scholar, Trevis Huhn, gave Oxford the only win they had scored up to 1928. Then Bristowe won again, and after that came Lord Burghley's three successive wins, in the first of which he brought the record down to $24\frac{1}{2}$ secs., a figure that was equalled in 1923 by G. C. Weightman-Smith.

Neither in England nor America is there a Universities 440 yards Low Hurdles Race, if one excepts the Championships of the British Provincial Universities (record— $59\frac{4}{10}$ secs., D. McC. Bone, Liverpool University, 1924) and the 400 metres Hurdles Championship at the Pennsylvania Relay Meeting. England was before America in instituting a national 440 yards Low Hurdles title, the A.A.A. granting to the Amateur Field Events Association permission to hold a championship at that distance over 10 flights of 3 ft. hurdles in 1913. The first winner was E. B. Greer, L.A.C., who fell during the War when commanding a battalion of the Guards. His time was $63\frac{3}{4}$ secs. In the following year the A.A.A. took over the event, and it was won by J. C. English, Manchester A.C., in $55\frac{1}{2}$ secs., while the A.A.U. instituted an American Championship, won by W. H. Meanix, Boston A.C., in $57\frac{1}{2}$ secs. Sweden, also, instituted a 400 metres (437 yds. 1 ft. $4\frac{1}{2}$ ins.) championship in 1914, which was won by P. G. Zerling, A.I.K., Stockholm, in $61\frac{1}{2}$ secs. A 400 metres Olympic Championship was instituted in 1900, and this title was won at every Olympiad up to 1928 by America.

At the London Olympiad in 1908 America had two well-trying athletes in H. L. Hillman, who four years earlier had taken three Olympic titles at St. Louis—400 metres flat in 49½ secs., 400 metres hurdles (below regulation height) 53 secs., and 200 metres hurdles in 24½ secs. He was a short man of very sturdy build, and met his match in a tall young Irish-American, C. J. Bacon, who deprived him of his 400 metres hurdles laurels by 2 yards, in 55 secs. ; L. F. Tremeer, Great Britain, then over thirty years of age, whose sporting prowess is mentioned elsewhere, finishing 10 yards away, and L. A. Burton, Great Britain, giving up in the straight. In 1920 F. F. Loomis, U.S.A., brought the world's and Olympic record down to 54 secs., and in that same race Georges André, France, was fourth, and C. Christiernsson, Sweden, fifth.

André deserves a special paragraph to himself. At the Olympiad of 1908 he was eighteen years of age and retained the distinction of being the youngest representative of a nation at the Games until H. A. Simmons, the Southampton School-boy High Jumper, represented Great Britain at Amsterdam twenty years later. In 1908 André, who stood 6 ft. and was well built in proportion, won the French 110 metres Hurdles in 15½ secs., but was selected to represent his country only in the Olympic High Jump. In that event he tied for second place with Con Leahy, Great Britain, and S. Somody, Hungary, at 6 ft. 2 ins., H. F. Porter, U.S.A., winning at 6 ft. 3 ins. At Stockholm, 1912, where there was no Low Hurdles race, he competed in the 110 metres High Hurdles and won a heat in 16½ secs., but did not get through to the semi-finals. Then came the War, and he fought all through it. In 1919 he made a French record of 25½ secs. for 200 metres Low Hurdles ; in August, 1920, he ran fourth in the Olympic race in which world's record was broken, and later in the same month set the French record for 400 metres Hurdles at 55½ secs. Glory enough, one would have said, and yet at the Paris Olympiad, 1924, at thirty-five years of age and as the senior athlete competing, he took the Olympic oath of amateurism on behalf of all contestants. In competition he finished again fourth in

the 400 metres Hurdles, in which F. M. Taylor, U.S.A., returned 52 $\frac{3}{4}$ secs., but had his world's record disallowed as he had not left all the hurdles standing, E. Vilen, Finland, being a very good second. And what is more, André, on the eve of the forties, very nearly qualified for the French Olympic team in 1928.

In the years between 1924 and 1928 Lord Burghley discovered that the 440 yards was really his best hurdling distance, and he found too a fellow Cantab. to back him up in T. C. Livingstone-Learmonth. From 1926, in which year he beat his fellow Blue in 55 secs. after they had crossed the last hurdle together, Lord Burghley swept all before him. In 1927 Sten Pettersson, who in 1925 had made a world's record mark of 400 metres hurdles in 53 $\frac{1}{4}$ secs., came over to England from Sweden, but him Burghley disposed of in the semi-final of the A.A.A. Championships. In the final he beat a very fast Italian, L. Facelli, by 6 yards and equalled world's 440 yards Low Hurdles record of 54 $\frac{1}{4}$ secs., made by J. K. Norton, U.S.A., in 1920. There was a curious coincidence about this, for on the same afternoon but about five hours later, Johnny Gibson, Fordham University, won the American title in 52 $\frac{3}{4}$ secs., but that record did not go on the books until a year later.

In the preceding April Lord Burghley and Livingstone-Learmonth had gone to America and competed at the Pennsylvanian Relay Carnival. There they met Johnny Gibson, who defeated them both by half a yard in the 400 metres Hurdle Race (No. 1, Plate 21) in 55 $\frac{1}{2}$ secs. The American was, however, afterwards found to be ineligible to compete, and the race was awarded to Lord Burghley with T. C. Livingstone-Learmonth placed second.

Early in 1928 it was apparent that both the Cambridge Blues were reaching the top of their form, and at the A.A.A. Championships Burghley again beat Livingstone-Learmonth on the run-in in 54 secs. flat. That was not quite up to Gibson's still unaccepted world's record performance, of course, but still the British followers of athletics were quietly confident that success would be obtained at Amsterdam at the end of that July. Their faith was fully justified.

In the first heat of the 400 metres Low Hurdles final at Amsterdam, F. M. Taylor, U.S.A., who three months earlier had set the world's record at 52 secs., came home first in 53½ secs., followed by F. J. Cuhel, much fancied by the Americans, and Lord Burghley, all three qualifying for the final. Livingstone-Learmonth, in his heat, drew Johnny Gibson, R. Maxwell, another good American, E. Vilen, Finland (2nd 1924), Sten Pettersson, Sweden, former world's record holder, and L. Facelli, Italy, who had beaten him in London. In that heat of the semi-final the tall, strongly built Cambridge Blue made every fence a winning-post. I have seen him run many races, but never one like that. He beat the Americans, Swede, and Italian (two of them world's record holders) out of the race, and Vilen, second, and Pettersson, third, were well conquered in 54 secs. Perhaps in the final, run the next day, an inferiority complex told, for Burghley had always beaten him.

When the finalists came out we knew that we were to witness the race of a life-time. At the crack of the starter's pistol Cuhel, in the inside berth, hung fire inexplicably, but the rest of the field got away well together. At the second flight the Englishmen, in the outside lanes, were hurdling together first at each flight. Livingstone-Learmonth stuck the terrific pace for six flights, and then Burghley strode on alone. Entering the straight, he had all the Britishers on their feet and cheering frantically. The Americans were up too, for both Cuhel and Taylor were coming on fast. At the last fence Burghley faltered, and our hearts seemed to stop beating. Then he bucked over the last fence with Cuhel beside him and Taylor just behind, but once he was on the ground again, neither man could hold the fastest finisher in the world in this event. Lord Burghley's time of 53½ secs. was a new Olympic record and something much better than the figures suggest, for the track at Amsterdam was horribly loose in parts.

The continued beating of Livingstone-Learmonth by Lord Burghley is, I fancy, fully explained by the superiority of the latter's form over low hurdles. It was stated in the last chap-

ter that a 6 ft. man should be able to hurdle over a 3 ft. 6 ins. hurdle and under a cross-bar raised 5 ft. $9\frac{1}{2}$ ins. above the ground. With the low hurdles the case is different, and the low hurdler should cut out the body dip and tend to raise his body $2\frac{1}{2}$ ins. (*i.e.*, the head of a 6 ft. man just grazes a bar set at 6 ft. $2\frac{1}{2}$ ins. as he goes over a 3 ft. hurdle) instead of ducking under a bar set at 5 ft. $9\frac{1}{2}$ ins. as does the high hurdler. I do not mean that a man should go over a low hurdle with his body perfectly upright, but that, instead of dipping his body, he should maintain it at the true sprinting angle (see Fig. 3, page 52) during the hurdle clearance.

A careful study of the pictures illustrating this chapter will reveal most of the finer points of the low hurdler's action.

No. 1, Plate 21, depicts the great race at the Pennsylvania Relay Meeting in which Johnny Gibson, U.S.A. (leading) defeated T. C. Livingstone-Learmonth (nearest camera) and Lord Burghley (the third figure). Gibson is going too high, has got his shoulders out of alignment, and has turned the leading leg slightly over on to its side, which will make for a bad landing. Livingstone-Learmonth has straightened the leading leg rather too fully at the knee joint, but shows the correct body angle.

No. 2 shows Lord Burghley (farthest from the camera) beating S. B. Kieselhorst (Yale) in the 220 yards (2 ft. 6 ins. hurdles) in $24\frac{7}{10}$ secs. at the International Inter-University Match in London, 1927. There is no fault to be found with the form of either man. Burghley's and Kieselhorst's stretch of the straight leading leg and good body angle are especially noteworthy features.

No. 31, shewing the Oxford and Cambridge 220 yards Hurdles, 1927, portrays Lord Burghley again in perfect form. His preservation of the sprinting body angle and complete running form over the hurdle is remarkably good. Livingstone-Learmonth (farthest from the camera) reveals what happens to the athlete who tries to introduce the high hurdles body-dip into the low hurdles event. The forward dip is shortening his stride over the lower obstacle and has created a tendency to

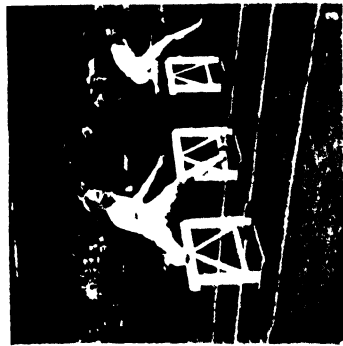

PH 21;

THE LOW HURDLES.

ST 21 and General PL 150

1. J. Gibson, U.S.A., World's Record holder, leading from T. C. Livingston, Leamouth, and Lord Burghley, U.S.A., 2. Lord Burghley, leading S. K. Gibson, U.S.A., 3. Lord Burghley proves that the low hurdler should not dip as Livingston-Leamouth, furthest from the camera, is doing. 4. Lord Burghley shows how the running action continues even when the feet are off the ground.



Pl. 22]

Sport and General. [L. 157

THE STEEPLECHASE.

1. V. E. Morgan, Public Schools Record holder. 2. J. E. Webster, English Championship holder. 3. Lord Burghley helping out the Empire against U.S.A. 4. T. C. Livingstone-Learmonth landing correctly at water-jump ahead of J. Montgomery, U.S.A.

pick up the rear knee to a height that is unnecessary over 2 ft. 6 ins. hurdles. Compare his cramped position with the freedom shown by his opponent.

No. 4 provides an admirable illustration of how completely Lord Burghley keeps up the running action over the obstacle and how perfectly that same action is carried on at the point of coming to ground for the next stride forward after hurdle clearance.

It should not be forgotten that the *average* length of leg of the type of man best suited to hurdle racing is 35 inches, so no difficulty should be experienced in "stepping" over the 30 inch hurdle used at the furlong distance, without altering the body angle; and a $2\frac{1}{2}$ ins. lift, as already mentioned, should enable the same type of man to go comfortably over the 36 ins. obstacle used in the 440 yards race. Do not forget that the old-fashioned "sail-over" style will destroy the form, while a too-pronounced body-dip over the 3 ft. and any body-dip at all over the 2 ft. 6 ins. hurdles imposes such a strain as will not allow the hurdler to cover the ensuing 20 or 40 yards on the flat between fences in good running form.

At both distances the straight-ahead, front leg action must be used and at the longer distance the high hurdler's rear hip action is to be employed, but without quite so pronounced a pick-up of the back knee. In neither event does the rear knee rise above the level of the hips as it is carried forward to commence the first stride after the other foot has landed. The front leg action requires a pick-up of the knee first, with the lower leg hanging directly below it until the foot is stretched forward, with toes pointing straight up to complete the step-over (see Livingstone-Learmonth's leading leg action, No. 1, and that of Lord Burghley, No. 2, Plate 21).

In the 220 yards event the body above the hips should not depart from the sprinting angle as the clearance is made. If the step-over is made correctly and the rear hip action is right, the whole clearance can be effected with the part of the body below the hips, but the rear hip action must be more of a swing than the snap up of the knee used by the high hurdlers.

Try to build up a facility for covering the 20 yards between flights of a furlong race in 7 strides, and, to help to build up this stride-form, accentuate the push off from the ball of the grounded foot at each stride—especially in clearance.

Low hurdle races are run in lanes nowadays, each man keeping to his own flight of hurdles throughout the race. There is considerable curve to the outer lanes and going round the bends the action of the arm nearest the inside of the track should be cut down, whereas the other arm must have a fuller swing; and, as further compensation, you should always lean to the inner side of your lane as you round the curves. Athletes who hurdle left leg leading have an advantage on a curved course, since the push-off from the right foot helps to throw the hurdler in towards the inner side of his own lane.

Standardize your approach run to the first fence. Corrections to bring you to the right take-off mark should be made in the first strides out of the holes, and not by lengthening or clipping the stride as you are nearing the hurdle.

In training for the Furlong Hurdles work first for endurance and leg strength. These are acquired by starting and sprinting practice, coupled with speed striding runs of 600 yards. On two afternoons a week these runs should be practised twice, and on two other afternoons in the same week practise full striding runs at 100 yards three times. Do the hurdling exercises (see preceding chapter) and gain speed by 50 and 100 yards sprint runs and 120 yards time trials over 2 ft. 6 ins. hurdles. When fit, 440 yards on the flat should be run once a week.

I think the reason that America has produced so great a number of fine quarter-mile hurdlers is to be found in the fact that many a young American who could touch 49 secs. for the distance on the flat and yet not win a championship, has turned his attention to the 440 yards 3 ft. hurdles as offering better chances of acquiring honours. That quarter-mile hurdlers have exceptional speed is proved by the fact that Johnny Gibson covered the distance and cleared 10 obstacles in $52\frac{3}{8}$ secs., while F. M. Taylor, U.S.A., is reputed to have run a $47\frac{3}{8}$, 440 yards on the flat in the British Empire *v.* U.S.A. Match, 1928. But

striding and hurdling form are still fully as important as speed.

There are two types of athletes usually seen in the 440 yards hurdles event—(1) The real sprinting quarter milers, who try to make their time on the ground up to and between the hurdles and on the run-in, and (2) the real hurdlers, who economize time and conserve energy in effecting hurdle clearance. Each type must work to acquire the good qualities of the other. The hurdler type has, I think, the advantage, because one cannot take a 3 ft. obstacle in the stride without hurdling form with the same facility that a 30 ins. obstacle may be negotiated.

The question of striding provides a big problem. Each man must solve it for himself in such a way that he gains regularity. Individuals vary, and 15, 17 and 19 strides between hurdles represent their different standards. Very few men, however, can hold to a set stride throughout a 440 yards hurdle race. I think, therefore, it is best to standardize the approach run, hold the set stride for three or four flights, then drop to a natural stride, clipping or lengthening the leg reach to suit the take-off, and try to get back to the set stride for the last two or three flights.

The 440 yards low hurdler must train his eye to estimate the right take-off spot when he is 12 or 15 yards from the hurdle, so that he can adjust his stride ; otherwise he must make his stride adjustment when he is right on top of the fence, and he will falter and shuffle.

To develop the full advantage of the natural stride method practise running at one hurdle from varying distances and learn to adjust the last five or six strides so that you will have no difficulty in effecting a proper clearance. There is no doubt that the time must come when men will maintain exactly the same number of strides between hurdles, but the novice who aims at this ideal too early, if he does not actually fall, will find his speed dwindling away over the last two or three flights. The goal to be aimed at for the furlong low hurdles race is to take 10 strides to the first hurdle, clear it in the eleventh stride, and take 7 strides between flights, going over on the eighth

stride each time. In the 440 yards race the first hurdle should be reached in 18 strides and cleared on the nineteenth ; thereafter 15 strides should be used to cover the distance between hurdles, with clearance effected on the sixteenth stride each time. Learn not to "tie-up" over the hurdle, but take it with the body as relaxed as possible and remember J. K. Norton's axiom : " There are lots of 'champions' for eight hurdles, but it is the last two hurdles that really tell the tale in the race."

Stamina you must have before everything else. Runs at 440 and 600 yards are needed. Starting and sprinting practice should play their part, quarter-miling at speed, work over 2, 3, and 4 hurdles. The form of the approach run and the finish run-in are also to be studied and practised, and there must be plenty of work done in perfecting take-off, clearance, and landing form. Limit the distance work to 440 or 600 yards. The 440 yards Hurdles event has now developed into such a sprint race, that running a half mile, which was formerly considered good training, is bound to slow men up.

CHAPTER XII

THE STEEPLECHASE—1,320 YARDS, 3,000 METRES, AND 2 MILES

STEEPLECHASING at sports meetings, as distinct from cross-country running, paper-chasing, and the old-time game of hare and hounds, is a fairly modern and somewhat artificial sport. This is not written disparagingly, for there are few, if any, contests that call for greater grit, staying power, pace judgment, and physical cleverness. It is a sport, moreover, at which a smart man over the hurdles and water jump will often beat a runner who can give him yards on the flat. This was well proved in the early seventies, when the Civil Service runner, C. J. Michôd, who might have been a great distance man, had he not lacked finishing speed, took up steeplechasing and became so really expert in negotiating the hurdles and water jump that he ran the great W. Slade, L.A.C., clean out of a steeplechase contest in which they met. The advantage Michôd gained from his excellent technique may be judged by the fact that Slade took the A.A.A. 4 miles flat championship of 1874 in 20 mins. 52 secs., and held the 1 mile title from 1873 to 1877 inclusive, returning as his best time 4 mins. 29½ secs.

Steeplechasing and hurdling both derive from the same source. In the earliest days of organized athletics steeplechasing stood as a test of distance running *cum* jumping, while hurdling provided a field for the sprinter who fancied himself also as a jumper. This theory is supported by the circumstance that at the first Oxford and Cambridge Sports Meeting in 1864, there were included a 2 miles Steeplechase, in which R. C. Garnett beat his fellow Cambridge Blue, R. E. Webster, by 6 yards in 10 mins., and two hurdle races at 120 and 200 yards

respectively. But after 1864 the Steeplechase was abandoned in favour of a 2 mile flat race, which was itself replaced by the present distance race of 3 miles in 1868.

In 1879, as noted elsewhere, two English Championship Meetings were held, and at the summer fixture, promoted by the L.A.C., a Steeplechase was included in the programme. Up to 1913 the conditions of competition and the distance of the race varied so that no useful guide to merit is supplied by the times recorded. Among many famous athletes who won Steeplechase titles, however, must be reckoned W. Snook, 1884 and 1885; A. B. George, brother of the great "W.G.," 1894, and G. W. Orton, New York A.C., 1898. From 1913 onwards the championship steeplechases of two miles have been held at Stamford Bridge; the course comprises eight laps, and includes thirty-two 3 ft. hurdle jumps, and eight water jumps. Among the post-War winners have been Percy Hodge, Surrey A.C., who held the title from 1913 to 1921, was beaten by Paavo Nurmi, Finland, in 1922, and regained the title in 1924. He gained also Olympic honours in 1920.

Hodge was a slight, pale-faced, and red-headed fellow, with so ungainly a gait that the foreign coaches, when they first saw him at Antwerp in 1920, declared that they had never seen a man with so many running faults travel at such a speed. I knew Hodge well in those days; he was a versatile humorist, and it is my opinion that half of his bad style was a cultivated mannerism to amuse the crowd. This was certainly so with his fantastic interchangeable styles of hurdling, and nothing pleased him better than to be allowed to stage an exhibition. His great stunt consisted of running over a series of fences with a bottle of beer and a glass balanced on a tray. It was an extraordinarily difficult feat to perform, but I never remember Hodge upsetting his load.

In 1900 and 1904 the Olympic Steeplechase was at 2,500 metres, and in 1908 at 3,200 metres. In 1920 the distance was standardized at 3,000 metres (1 mile 1,520 yards 2 feet), and Hodge walked away with the race in 10 mins. 2½ secs. The time would have been much faster, but Hodge never heard the lap

bell, and, having himself lost count of the laps, did not produce his usual finishing burst of speed in the last lap. In 1921 he reduced the English Championship record to 10 mins. 57½ secs.

Hodge was succeeded in the championship by that famous distance and cross-country champion, C. E. "Joe" Blewitt, and in 1925 J. E. Webster, also of the Birchfield Harriers, commenced his sequence of successes. In 1926 he returned 10 mins 34½ secs., and on the same afternoon won the four miles flat championship in 19 mins. 49¾ secs. He is a fine, robust athlete, and, had not a technical offence against the laws of amateurism prevented him from competing at Amsterdam, I think he might have gone near to retrieving the laurels Great Britain lost at Paris in 1924, when Willie Ritola, Finland, became Olympic Champion in 9 mins. 33¾ secs.

At Amsterdam, 1928, Finland won again, but there were some surprises. No British competitors qualified for the final, and Ritola and Nurmi both fared badly at the water jumps, added to which they had previously battled mightily against each other in the 10,000 metres and 5,000 metres flat races. Ritola retired from the final in its early stages, and Nurmi found himself faced with two younger Finns of exceptional quality. In the last phase T. A. Loukola went right away to win in 9 mins. 21½ secs., nearly 12 secs. better than Ritola's previous world's best time, and Nurmi was hard put to it to beat O. Andersen for second place. Thus Finland secured the first three places.

No University man has ever won the English Championship, and our British steeplechasers, like our British distance runners, appear to be losing their prowess. At any rate they are not showing the same rate of progress as the Finns. In the case of steeplechasing, however, we are not entirely without hopes of better things in store. In 1897 that very famous old-time long distance record-breaker, Mr. J. E. Fowler-Dixon, presented a three-quarter mile Steeplechase challenge cup to be competed for annually at the Public Schools Championships. The record for this race is 4 mins. 3¾ secs. and was made by V. E. Morgan, of Charterhouse, in 1923. (His portrait is Picture

No. 1, Plate 22.) Another famous winner was E. A. Montague, Rugby, 1918, who returned 4 mins. 8 secs. Both these athletes gained Blues at Oxford, and both have represented Great Britain at the Olympic Games. Since, moreover, upwards of fifty boys from some twenty-five schools meet in the Public Schools race each year, it is obvious that British interest in steeplechasing is not as yet quite dead.

Montague was one of the greatest distance runners that the track has ever seen, and perhaps the most unlucky one. At Rugby he won the famous 13 miles Crick Run, in which his younger brother, F. A. Montague, was successful later on, a point of interest, since this is the only instance in the long history of the race of two brothers proving successful. At his first public appearance, E. A. Montague won both the Public Schools steeplechase and mile. His versatility is proved by the fact that in 1920 he beat W. R. Seagrove at three miles in a gale of wind in 10 mins. 45 $\frac{3}{4}$ secs., won the mile against Harrow, and was second to B. G. D. Rudd in the half mile. There is reason to say that he was unlucky, for he finished second in no fewer than five English Championship races. The occasion of the 1921 Steeplechase Championship will not be soon forgotten. Throughout the race Hodge and Montague passed and repassed each other continually. The last lap found Hodge very groggy and his opponent hardly able to clear a hurdle, but in the finish Hodge, through better hurdling, won a terrific struggle by 7 yards.

There is a good tale told of the occasion when Montague represented England against France at 5,000 metres. At the bell he was lying behind Seagrove and was just about "all in." Although his legs were giving under him and he wobbled from side to side of the track, he yet succeeded in passing Seagrove and securing fifth place for England. When asked afterwards why he did not give up as he was so acutely distressed, he replied, with a smile, that he had run on in the belief that Seagrove was a Frenchman.

The sport calls for pluck and staying power, and the man who essays this event must be able to preserve uniformity of

pace, which he will acquire in training by having a friend time his runs, so that a racing schedule may be planned. Good form over the hurdles is to be acquired by the methods recommended in Chapter XI, with the exception that the steeple-chaser does not need to develop quite so much snap over the obstacles as is required in a 440 yards hurdle race, but must practise much at running at his hurdles from various distances, to acquire the facility of taking them in his stride without any hesitation.

The water jump is often the crux of the race. It consists of a hedge and water-filled ditch. The hedge is something over three feet in height and the ditch, which is too wide for most men to jump, is three feet deep at the foot of the hedge, whence it slopes upwards to the landing. The conservation of energy and the maintenance of speed throughout the race are dependent largely upon the economy with which this difficult obstacle is negotiated. Some men rush it in the hope of taking the whole affair in their stride. Should they succeed in so doing they have used up far more energy than is warranted by the saving in time they have effected. Others, anxious also to avoid the water, climb or jump to the top rail, running through the hedge, and spring thence across the ditch. The climbers waste an unconscionable amount of time; the others risk a nasty fall in taking off from the insecure foothold of a flimsy rail.

The best plan is to speed up one's running about twelve yards in front of the hedge and to spring over it easily as J. E. Webster is doing in No. 2, Plate 22. This action allows the athlete to fall naturally into the water, but he must never land on both feet. The speed in approaching the hedge should be increased just sufficiently to enable him, in the jump, to land on one foot so far forward in the shallow water that the next step will carry him clear of the ditch and on to dry land. T. E. Livingstone-Learmonth, C.U.A.C., and British Empire Team, 1928, shows this action to perfection in the accompanying illustration (No. 4, Plate 22). J. Montgomery, of the U.S.A. team, who is following Livingstone-Learmonth, is making the

mistake of dropping into the deep water at the foot of the hedge, and, if my memory serves me, let himself in for a first-class ducking.

TRAINING

The Steeplechase is often treated by both spectators and contestants as something of a joke. In reality it is a strenuous event, for which long, hard and serious training is required. Cross-country work in the winter is the best preliminary preparation; without this it will take the best part of three months' training to bring a man to competition condition. Long walks, with a quarter (increased to a half) mile trot in each mile, provide the work for the first month. But, in addition, hurdling at half-speed, with concentration on running at the hurdles from varying distances, should be practised.

In training for a 2 miles Steeplechase it is necessary to run $3\frac{1}{2}$ to 5 miles twice a week, and the athlete must begin to build up his finishing speed, working up from 220 to 660 yards. The number of flights in the hurdling practice should be increased. Body-building and breathing exercises and skipping should be included in the training schedule.

If the distance aimed at is the Public Schools three-quarter mile event, halve the distances given in the preceding paragraph, except in the case of the finishing sprint.

Reduce the distance work in the third month, working from half a mile for speed to three miles for endurance. Hurdle practice should be on two days a week and running on three days. Keep up the hurdling exercises and work at the water jump. Time trials may be run on the first and second Saturdays of the third month. This schedule will serve also for those preparing for the Public Schools Championship.

Always rest on Friday and take no more exercise than an easy stroll after lunch on Sundays. Finish off your training on the Tuesday or Wednesday preceding the race for which the preparation has been undertaken.

CHAPTER XIII

CROSS-COUNTRY RUNNING

ENGLISH Cross-Country racing, which was the basis of Great Britain's long reign as a distance running nation on track and road, had its origin at the Public Schools. The Crick Run at Rugby, the Shrewsbury and Eton Steeplechases, and several other similar events have been mentioned elsewhere in this volume. Although the Crick Run was founded at Rugby in 1837 there is some evidence that Shrewsbury held cross-country races at an even earlier date. From this beginning was evolved the Shrewsbury custom of holding set runs once a week during the Christmas term. I do not know how far the old ceremonial has survived, but in former years the Shrewsbury School "Huntsman" used to appear resplendent in black-velvet cap with crossed golden whips on the peak, a bright scarlet jersey, and stockings. In his hand he carried a hunting horn. The first and second "whips" carried hunting crops, the former leading the pack and the latter acting as whipper-in.

The "Gentlemen of the Runs," who formed the first division of the pack, ran coatless and carried a short bludgeon, as a defensive weapon against the town "toughs," who took a delight in stoning the boys. Latterly the "gentleman's" bludgeon became the record of his prowess. It was ringed in years and a notch cut for each run. The notch was replaced with a cross to mark a win, or "kill," and a square bracket substituted to denote a second place.

The second division, or hounds, used to run in jackets and mortar-boards, from which every atom of stiffening material had been removed. Anything up to 130 couples of hounds

Athletics of To-day

would start in an ordinary run, but for the longer distances, varying from 9 to 12 miles, six or eight picked "couples" only were allowed to start. The first half-dozen boys home were allowed a hot supper at the shop, at the club's expense. These "runs" culminate in Senior and Junior Steeplechases over very stiff Shropshire country, and the boys are equipped with hedging gloves sewn to the sleeves of their jerseys.

At Rugby, where the course crosses water where Clifton Brook runs slow and muddy down a sheltered green valley to meet the Avon, water jumps and a few stiff-set hedges supply the obstacles, and at Bradfield the course follows the valley of the Pang, and the finish is made through about 15 ft. of deep water in a trout pool, while at Sedburgh the run is over all of 10 or 12 miles of real hill country.

The extension of cross-country running beyond the schools and the foundation of the English Cross-Country Championship, however, had their inception with the Thames Rowing Club. Towards the end of 1867 a few members of the club conceived the idea of holding some cross-country steeplechases, whereby the rowing men might keep themselves in training during the winter months. The idea originated with the late Mr. Walter Rye, whose prowess has been already recorded. He drew his inspiration in this particular instance from the description of the Barby Hill Run in *Tom Brown's School Days*. He was the founder also of the Thames Hare and Hounds Club, which was the first of its kind to be founded, so that Mr. Rye was long known as "The Father of Paperchasing."

The arrangements for the Thames Handicap Steeplechase No 1, as it was termed, were, Mr. Rye told me, of a primitive order. The runners were conveyed in an old-fashioned horse omnibus to Beverley Brook on Wimbledon Common (the crucial point in many subsequent Oxford and Cambridge Cross-Country contests) and there they changed into running kit as best they could. The race that followed was 2½ miles over swampy ground, run in the dark, but history does not relate who won.

The second handicap was notable for many reasons. The

judge was, appropriately, Mr. T. Hughes, for no man ever wrote a finer description of cross-country running than that of the Barby Hill run in *Tom Brown's School Days*. The field numbered twenty-four, with the great W. M. Chinnery at scratch, but he did not start. There were Old Boys of Eton, Rugby and Marlborough, and R. E. Webster, later to become Lord Chief Justice of England. At the cross roads 300 yards from home, eight runners were all bunched together; then King, Webster, Chappell and Hawtrey, the old Etonian, drew ahead to finish in that order; a yard separated first and second, fifteen yards between second and third, and half a yard between third and fourth.

The Thames Hare and Hounds Club then came into being; two old Rugbeians, who had made records for the Crick and Barby Hill runs, became members, and on October 17th, 1868, the first club run—a paper-chase—was held from the King's Head, Roehampton, a quaint old inn, built of wood and overshadowed by a mighty wych-elm.

The next club to come into being was the Peckham A.A.C., which, long ago, changed its title to that of the Blackheath Harriers. This was followed, I believe, by the still irrepressible South London Harriers and the Spartan Harriers (now defunct, I fancy) of North London, whose very energetic secretary, H. M. Oliver, transferred his activities to Birmingham, and had a great deal to do with founding two famous clubs, the Birchfield Harriers and the Moseley Harriers. From Birmingham, Oliver journeyed to London in the summer of 1879 and won the first English Track Steeplechase, running in the colours of the Moseley Harriers.

Meanwhile the Thames Hare and Hounds had contested two matches with the Gentlemen of Hampstead in 1870, and there had been meetings between teams of various clubs right up to 1876. In that year the first National Cross-Country Championship was held in the wilds of Epping Forest. It proved a complete fiasco, for every one got lost.

In the next year a course of about 12 miles was planned from Roehampton over Wimbledon Common past Merton, Morden,

West Barnes and the Crooked Billet, home. Thames won with an aggregate score of 35, South London being next, 58, and the Spartans third, 94. The Spartans won in the next two years, but from 1877 to 1880 inclusive, Thames provided the individual winner in P. H. Stenning. His best time was 68 mins. and that is well inside 10 miles an hour for the whole course. Thames won again in 1879, and then the Midlanders began their day, Birchfield winning with a wonderfully trained team in 1880 and Moseley achieving the honours in 1881.

The men who ran in the Midland teams were all drawn from the artisan or labouring classes, a circumstance which caused no small dissatisfaction among the gentlemen amateurs of the South. Nowadays athletic sport is for all classes from the lord to the labourer, and rightly so, but there was a good deal to be said for the views of the Southerners in the seventies and eighties, for, undoubtedly, roping and betting did both prevail to an appalling degree. Authority was quickly being established, however, through the formation of a national governing body and district associations. The Midlands held their first championship in 1879, the North followed in 1883, and the South in 1884.

In the North, Salford and Hallamshire have just about divided the honours between them ; in the Midlands, Birchfield have been predominant ; and in the South, Highgate had things much their own way until Surrey started a four years' run of success in 1922, which was broken by Highgate in 1926, who in their turn lost the title to the S.L.H. in 1927.

The greatest record for Cross-Country running undoubtedly belongs to the Birchfield Harriers, who owe so much to their Honorary Secretary, W. W. Alexander, the Grand Old Man of athletic sport in the Midlands, for they have won the national title sixteen times since 1877 and the Midland title twenty-seven times in the thirty-two races held up to 1929. In 1884 the National was won by W. G. George, wearing the Moseley colours, in 1885 by W. Snook, Birchfield Harriers. From 1901 to 1904 Alfred Shrubbs, S.L.H., was National Champion,

and in the two latter years led England to victory in the newly-established International Championship.

The International Championship has been decided at different times in England, Scotland, Ireland, Monmouthshire for Wales, France, and Belgium. From 1903 to 1921 England remained unbeaten as a team, although Jean Bouin, France, was first man home from 1911 to 1913, and J. Guillemot led France to her first team victory in 1922, France winning again in 1923, 1926 and 1927. No other countries had gained the championship up to 1927.

The Oxford and Cambridge Cross-Country Race was founded in 1880, the same year that the Amateur Athletic Association was formed, and the National Cross-Country Championship received its first provincial entry. For fourteen years the Oxford and Cambridge event was decided at either University in alternate years. In 1890 a neutral course was agreed upon, and in 1895 the fixture was moved to the Roehampton-Beverley Brook-Wimbledon Common run. The first race in the new surroundings ended, like the first attempt to run a National Championship in 1876, in complete disaster through the runners of both teams losing the trail. No such calamity occurred again in the thirty years that followed. During that period the course was slightly varied three times.

By 1925 the Roehampton-Wimbledon run had lost its real cross-country character, and it was decided to seek a new locality. An excellent course was discovered at Horton Kirby, near Farningham in Kent, and to that neighbourhood the race was moved in 1926. The present course is harder and more hilly than the old one ; but, curiously enough, that made no difference to the time in which the winning Oxford team were able to traverse the $7\frac{1}{2}$ miles of stiff country. That year Oxford were superlative. Ivor Thomas, W. A. M. Edwards and L. A. B. Cooke, indeed, started out at such a pace as broke up most of the Cambridge men in the first mile or two. Edwards reached the winning-post first in 44 mins. 11 secs., with other Oxford men finishing second, third, fourth and fifth, the team thus returning the lowest possible score.

Athletics of To-day

Between the years 1880 and 1928 inclusive, Cambridge have won twenty-five times, and Oxford nineteen times.

The first Inter-Counties Cross-Country Championship was held in 1926. At a meeting of representatives of County Associations held after the race, the Counties Athletic Union came into being, and has since continued to promote this most important cross-country championship, which is adding a strong incentive to cross-country running throughout the Midlands and South of England.

Cross-Country running is now almost entirely a team sport, and since the training of the individual is looked after most carefully by his club there is no need for me to say anything upon that score. Most cross-country runners, indeed, keep in training all the year round by competing in the distance track events during the summer season. Cross-country running gives the legs a variety of work to do up hill and down, over smooth ground and rough, and so the athlete who indulges in it must aim at always having perfect control over his body and legs. The changing character of the ground generally causes the novice to run tensed up, but this must be changed to an easy relaxed style if success is to be achieved. One should learn to lengthen or shorten the stride and to balance the body in accordance with the nature of the country. The arms should be carried loosely and swung exactly as if one were working at a distance on the track.

The cross-country runner must, of course, be something of a hurdler and jumper, in order that he may surmount the natural obstacles which will confront him.

Overcome hills with a shortened stride, but go down them running loosely and resting a little longer than usual on the heel at each stride.

In very cold weather run in a high-necked sweater and wear long drawers under the shorts; you will travel faster warmly clad and avoid risk of cold.

Cross-country running is now popular in many lands, and the French have beaten us over real country, just as the Scandinavians have overcome us over the rather futile courses in

three Olympic races that have been held. At Stockholm, where the distance was about 8,000 metres, the placing was Sweden, Finland, Great Britain, with H. Kolehmainen, the Finn, first man home. At Antwerp, 1920, the distance was standardized at 10,000 metres (almost $6\frac{1}{4}$ miles), and the order was Finland, Great Britain, Sweden, with Paavo Nurmi finishing well ahead. At Paris, 1924, there was such a débâcle as caused the event to be omitted from the programme at Amsterdam in 1928.

July 12th, 1924, was a day of tropical heat, and although the runners did not start until half-past four in the afternoon and the course was not a hard one, some fears were expressed on account of the intense heat, but no one dreamed of the pitiful sight we were to see at the finish. Early in the race Nurmi and Ritola (Nos. 2 and 1, Plate 23), followed by Wide, Sweden, got away on their own, but even Wide could not live at the pace those two Finns set, and after a while Ritola himself could not hold Nurmi. Even with this news ringing in our ears from the loud-speakers, we did not realize the pace at which Paavo Nurmi was travelling, and when a great shout gave warning that he was approaching the Marathon Gate the 400 metres Relay heats, which were in progress, had to be stopped.

I shall never forget the spectacle of that Finnish superman as he appeared and trotted round the arena, while the air rocked with cheering that seemed not to interest or please him one atom. He finished his race, apparently as fit as when he had started, took off his shoes, and had walked half-way across the ground before Ritola arrived a full minute behind him, and he too showed but slight signs of distress. Then came R. E. Johnson, U.S.A., 300 yards behind Ritola, with E. Harper, Great Britain, another 200 yards behind him. These men looked absolutely done, and Harper indeed collapsed completely as he passed the winning posts. The fifth man, a Spaniard, fell flat on his face as he came through the Marathon Gate and was carried away. A. N. Sewell, Great Britain, came next and turned the wrong way into the track. Officials shouted at him, but he was past understanding; some one

Athletics of To-day

turned him round, and he staggered blindly towards the grass, cannoned into a Finn, and collapsed. The Finn was passed by Laveaux, Freude, and Studenroth, U.S.A., but staggered on until a few yards from the tape, when he turned and began to run stumbling back. The frantic shouts of his countrymen, however, urged him to a supreme effort of will over suffering body, and he commanded his senses, turned again, and accomplished his task.

Meanwhile, out in the country, men were lying scattered, some almost at death's door. Wide and some others were brought in exhausted and unconscious, and yet others were still being found and picked up at seven o'clock. That was the most dramatic of very many hundreds of races that I have witnessed, and when, finally, a game little Frenchman struggled home with one foot bleeding and one shoe gone, the whole crowd rose to him and roared in acclamation.

Just think of it in retrospect! Man after man came in utterly exhausted, others fell by the wayside and had to be given strychnine to save their lives, and yet the Finns, Nurmi and Ritola, finished as fresh as if they had only trotted a time or two round the track. There is little wonder that we barely bothered when we heard that Finland had won the team title from America and France.

The next afternoon, Nurmi and Ritola not only ran, but finished first and second in the 3,000 metres team race, which also was won by Finland from Great Britain and America, Nurmi incidentally establishing an Olympic individual record for the distance of 8 mins. 32 secs., and he had won the 1,500 metres in the new Olympic record time of 3 mins. 53 $\frac{3}{4}$ secs., and the 5,000 metres in 15 mins. 31 $\frac{1}{2}$ secs., yet another new Olympic record, thus, I feel convinced, stamping himself as the greatest middle distance runner of all time.

Both America and Finland will be forces to reckon with, if ever they enter for the International Cross-Country Championship. For Finland has proved her merit and is producing better and better distance runners at every Olympiad; while, in America, organised cross-country running dates back to

1890, in which year W. D. Day, New Jersey A.C., took the Senior A.A.U. individual title, and the Prospect Harriers, of Brooklyn, the team honours.

The Inter-Collegiate Cross-Country Association of America looked after the sport at the Universities and Colleges from 1899 to 1907, but from 1908 the Cross-Country Championships have come under the control of the Inter-Collegiate A.A.A.A. In the first period the races were run at an approximate distance of $6\frac{1}{2}$ miles, but since the I.C.A.A.A. took over, the distance has been reduced by half a mile. J. F. Cregan won the first Inter-Collegiate contest, and Cornell took the team championship.

There is an Inter-Scholastic Championship for High Schools at 3 miles, which corresponds to the English Public Schools Cross-Country run of 5 miles for the Ranelagh Cup.

For many years after the foundation of the Public Schools Track and Field Championships by the L.A.C., the need of a corresponding cross-country event was often discussed, but nothing was done until the autumn of 1926, when a few members of the Ranelagh Harriers put a suggestion before the Committee. As the outcome of this the famous club, founded in 1881, issued invitations to the Public Schools to take part in a race over five miles of country from the Green Man Inn at Putney. A fair number of schools accepted, and on April 16th, 1927, the first race was won by Lancing, 16 points, from Strand, 30 points, St. Dunstan's, 61, and Ardingley, 65 points. Lancing had the first two men home in R. E. Cowburn, 28 mins. $3\frac{3}{4}$ secs., who was second in the Oxford and Cambridge race, 1928, and A. S. Bookless, 28 mins. 14 secs.

In 1928, Lancing retained the challenge cup with 13 points from Taunton, 58 points, and Bedford Modern School, 62 points. Lancing again placed the first two men, Bookless winning in 29 mins. 14 secs., from J. Robins, 29 mins. 31 secs.

The race is open to teams of six runners, of whom four score, and to individual entries from Public Schools.

CHAPTER XIV

THE WALKS

THE sport of walking has enjoyed a longer and a greater popularity in England than elsewhere, although of late years Italy and Denmark have produced some really great exponents of the "heel and toe" code of foot racing. Foster Powell, mentioned in Chapter IX, probably gave modern athletics their general impetus towards standardized organisation and practice, but he was really neither walker nor runner, since his *forte* took the nature of "go-as-you-please" contests over great distances. It is from Captain Barclay Allardice, whose triumphs have been mentioned in Chapter I, that modern race walking may be said to derive. He was, by all accounts, a fine character, as well as a great athlete, and he inspired the writing of the first book on Pedestrianism, which was published in Aberdeen by Mr. Walter Thom in 1813.

Needless to say, the feats of Captain Barclay created an enormous amount of public interest in athletics and brought him a host of imitators, and in 1864, when the Oxford and Cambridge Sports were started, walking was popular at both Universities, although no walking event has ever been included in the Inter-Varsity Sports programme. At that period, seven miles was considered the proper distance at which to test a man's walking speed and endurance, and that was the distance of the walking event included in the first English Championship Meeting of 1866.

The first English champion was J. G. Chambers, C.U.A.C., a fine, tall athlete, who was opposed by three other University men. His winning time of 59 mins. 32 secs. does not strike one as anything remarkable, but he could certainly walk his seven



Pl. 23]

Sport and General [M 170

CROSS-COUNTRY RUNNING. WALKING.

1. W. Ritola, Finland, showing easy carriage of cross-country runner. 2. P. Nurmi, Finland, showing strong finishing action in cross-country race. 3. G.V. Bonhag, U.S.A. Olympic Walking Champion 1906. 4. G. E. Larner, Great Britain, World's Record holder and Olympic champion, 1908



Pl. 24]

Sport and General. [N 177

THE HIGH JUMP.

H. M. Osborn, U.S.A., World's Record holder, 6 ft. 8½ in., showing three phases in clearance in the "Western Roll" Style.

miles within the hour and was an exceptionally fine oarsman. Apart, however, from his athletic ability, he should be remembered as one of the pioneers of the athletic movement both in London and at the Universities.

Since Chambers's championship was won no University man has ever taken an English walking title, and from the late seventies onwards all interest in walking as an athletic sport has died out at Oxford and Cambridge. In 1867, Chambers was beaten a foot by J. H. Farnworth, Liverpool A.C., after a tremendous battle down the home stretch in which the style of both contestants was "remarkably suspicious."

The next champion was Walter Rye, L.A.C., 57 mins. 40 secs. Rye and his chief opponent, T. Griffith, S. Essex A.C., who was to win in the succeeding years when Rye did not compete, and reduce the record to 55 mins. 30 secs. in 1870, were both tall men, and Rye walked very upright with a good straight leg action. S. P. Smith, a lad of nineteen, who was taller than either of them, indeed well over 6 ft. in height, proved a great sprint walker and had brought the two miles record down to 15 mins. 15 secs. by the end of 1867.

Three great figures in the latter seventies were W. J. Morgan, an employee of Shoobred's, H. Venn, L.A.C., and H. Webster, Stoke A.C. Morgan, who had a light, springy stride, often puzzled the judges, while Venn and Webster, who started as perfectly fair "heel-and-toe, one-foot-always-on-the-ground" walkers, deteriorated later on, and to such an extent that towards the end of the championship race in 1877, which Webster won in 53 mins. 59 $\frac{3}{4}$ secs., and, again in the next year when Venn turned the tables and reduced the record to 52 mins. 34 $\frac{1}{2}$ secs., it is said that "both men were running under the nose of the referee of walking."

The year 1881 brought over the first American seekers after English titles, E. E. Merrill, a Boston watchmaker, who had held the U.S.A. three and seven miles walking titles, accompanying "Lon" Myers, the quarter-miler, but not sharing his famous friend's success. Merrill was a fair and fast walker, but better suited at the shorter distances. Nevertheless, it

seemed that the English title of 1881 was at his mercy, for Webster was definitely past his prime, and I doubt if many people had heard of the Yorkshire novice, J. W. Raby. Notwithstanding his lack of fame, the tall, thin Elland lad, after Merrill had walked Webster into disqualifying himself, tackled the American and had him so thoroughly worn down at five miles that Merrill was forced to retire soon afterwards. Raby, it is said, showed none of the track walker's mannerisms in action, but moved along exactly as if he was taking an ordinary fast walk along the road.

The modern generation of speed walkers started, I fancy, with H. Curtis, Highgate Harriers, who was champion from 1890 to 1893. Curtis was noted for his upright carriage, fine free striding, and absolute fairness of action. In his first championship, at Birmingham, he broke three records, covering five miles in 37 mins. 17 secs., six miles in 44 mins. 37 secs., and seven miles in 52 mins. 28½ secs.

W. J. Sturgess, Polytechnic Harriers, who won the English title of 1902 in 52 mins. 49½ secs., succeeded subsequently in breaking all records from one mile in 6 mins. 33½ secs. to seven miles in 51 mins. 27 secs., ten miles in 1 hour 17 mins. 32½ secs., and thirteen miles in 1 hour 42 mins. 59½ secs.

Then came the great days of the Britishers, G. E. Larnier and E. J. Webb, and the beginnings of G. Goulding, of Canada, the Dominions at that time being very strong in walking.

Larnier was born at Langley in Buckinghamshire in 1875, but did not take up athletics until he was twenty-eight years of age. In his second season, 1904, he won the A.A.A. 2 and 7 miles titles. In the following year he retained both and established world's records from 1 to 8 miles, of which only that for 7 miles has since been broken. Finding that police duties at Brighton interfered with his training, he retired from the track at the end of 1905; but, fortunately, was persuaded and obtained permission to train for the Olympic Games in 1908.

At the Games, Larnier and Webb were in a class by themselves and finished first and second in the 3,500 metres and 10 miles walks, both newly instituted events. Larnier at the

longer distance established world's records for 9 miles in 1 hour 7 mins. 37½ secs., and 10 miles in 1 hour 15 mins. 57½ secs., while Webb returned 1 hour 17 mins. 31 secs. for the full course. Larner is seen finishing this great walk in No. 4, Plate 23.

Webb was then a man of thirty-six years of age. He was born at Hackney in 1872, and had a "variegated" career behind him. At twelve years of age he went to sea and after knocking about the world for some years joined the Army and was with the Cavalry in the British retreat from Dundee to Ladysmith during the South African War. Later he took a job with Messrs. Faulkners, the tobacco importers, and turned his attention to walking. He won the English 2 miles in 1909 and 1910 and the 7 miles in 1908, 1909 and 1910, Larner returning to take the title in 1911. At the latter distance, Webb, in 1910, set the Championship record at 51 mins. 37 secs., which still remains unbroken. But the old soldier never won a world's championship. At the London Olympiad he was overshadowed by Larner. At Stockholm, 1912, when forty years of age, he was beaten by less than 11 secs. by G. H. Goulding, Canada, whose walking in the Olympic heats four years earlier had created a very favourable impression. In 1912 the only Olympic walk was at 10,000 metres, for which Goulding returned 47 mins. 14½ secs., but in 1915 he reduced the world's 7 miles record to 50 mins. 40½ secs.

Meanwhile, T. E. Hammond, a Stock Exchange clerk, had in 1907 walked from London to Brighton and back (104½ miles) in 18 hours 13 mins. 37 secs., H. V. L. Ross, in 1909, had covered 52½ miles, London to Brighton, in 8 hours 11 mins. 14 secs., S. C. A. Schofield had set up new figures from 22 to 25 miles in 1911, and E. C. Horton had altered the records from 51 miles in 8 hours 8 mins. 25½ secs. to 73 miles in 11 hours 59 mins. 19½ secs. in May, 1914.

We were then at the beginning of the rise of the foreign walkers, and the British Empire ceased to provide Olympic champions. On July 29th, 1913, Altmani Fernando, an Italian, made noteworthy performances, starting with half a

mile in 3 mins. 7 secs., up to 13,000 metres in 58 mins. 17 $\frac{1}{2}$ secs. Intermediate times taken at twenty-three distances were accepted by the I.A.A.F. as "noteworthy performances" only, as there were only two timekeepers present. This was bad luck for the Italian, as several of his intermediate times were better than world's records.

In 1918, Denmark produced two great walkers in G. Rasmussen, 3,000 to 15,000 metres, and N. Petersen, 20,000 to 25,000 metres. The records made by Rasmussen still stand, but those of Petersen were eclipsed at the shorter distance by D. Pavesi, Italy, in 1927, and earlier in the same year A. Schwab, Switzerland, did a better time for the longer distance. Pavesi was a dapper little walker and always wore a linen cap of blue and white triangles with an enormous jockey peak.

At the Antwerp Olympiad, 1920, where there were again two walks, we saw Ugo Frigerio, a slim, swarthy young Italian, who also walked in a peaked jockey cap, win the 3,500 metres very easily from C. L. Parker, Australia, with C. S. Dowson, the English 7 miles champion, fourth, in the new world's record time of 13 mins. 14 $\frac{1}{2}$ secs., and the 10,000 metres by 300 metres from J. B. Pearman, U.S.A., with C. E. J. Green, Great Britain, third, C. C. MacMaster, South Africa, fourth, and W. Hehir, Great Britain, fifth, establishing yet another world's record of 45 mins. 26 $\frac{1}{2}$ secs.

At Paris, 1924, where there was again only one walk, Frigerio retained his 10,000 metres laurels, beating G. R. Goodwin, the English 7 miles champion, C. C. MacMaster, South Africa, and his fellow Italian, D. Pavesi. These Italians were extraordinarily fine walkers with a style that was above suspicion.

At Amsterdam in 1928 there was no walk, but at the ninth Congress of the International Amateur Athletic Federation, held at the time of the ninth Olympiad in Holland, it was decided to reinstate walking at the tenth Olympiad to be held at Los Angeles, U.S.A., in 1932, the race, starting and finishing in the stadium, to be at a distance of 50,000 metres (approximately 31 miles 120 yards) on the roads. It will be, in fact, a "Marathon walk." At the same Congress the definition of

what constitutes fair walking was altered to read—"Walking is progression by steps so taken that unbroken contact with the ground is maintained."

The position of America in relation to walking needs some explanation. A three miles race was held from 1876 to 1896 and resumed in 1907. The seven miles walk was instituted also in 1876 and has been in and out of the programme several times, until it was finally reinstated in 1912. The standard of comparison between America and Great Britain must be the seven miles walk, and at that distance Britain was markedly superior until recently, but in 1926, Harry Hinkel, who, no doubt, would have done well at Amsterdam had there been an event for him, took the U.S.A. title in 52 mins. 56½ secs. and returned 53 mins. 11½ secs. in 1927, both better performances than have been seen at the English Championships, since G. R. Goodwin took the A.A.A. event of 1924 in 52 mins. 0½ sec.

Walking, somehow, does not appeal to any large portion of the American public, although there was a one mile event in the Inter-Collegiate Championship programme from 1877 to 1898. The sport has disappeared also from the programme at general sports meetings in the States, and would certainly have died right out in America had it not been included in the Olympic Games.

Track walking and road walking, of course, provide two different kinds of sport, and a consequent differentiation of action, but both supply as much stiff exercise and stamina searching work as any man can desire. A further cause for strain is found in the circumstance that the walker cannot let himself "all out" in the full sense of the term, when he is pushed, but must continuously concentrate his mind upon preserving the fairness of his action. The new rule, already referred to, defines quite clearly what is fair walking, and the old pedestrian ruling "heel-and-toe, one-foot-always-on-the-ground" is equally explicit, and yet it takes a mighty good judge to tell when a man is "lifting." The real tests of a fair walker, I think, are to be found in the carriage of the head, body, and legs, and the way in which the knees are locked at

the end of the stride and the grounded leg kept stiff and taut as the other leg swings loosely forward for the next stride, in which the heel is the first part of the foot to make contact with the track (see No. 3, Plate 23).

There must, naturally, be good arm propulsion, the clenched fists swinging up and right across the chest to in front of the opposite shoulder with a powerful drive. The arms are held bent at the elbow, and as each fist reaches its highest point the other should drop back in rear of the hip. Walk freely with swinging shoulders and loose hip play and have the head and body upright at the end of each stride. (Note G. V. Bonhag, No. 3, Plate 23.)

Another necessary adjunct to good race-walking is the rotary movement of the lower girdle of the body. The action gives the athlete added stride-length, but this movement postulates extreme suppleness in the small of the back. At the

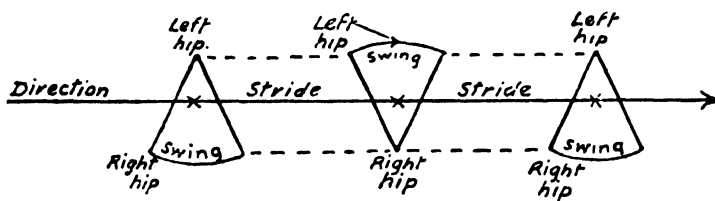

FIG. 12.

lower end of the human trunk are the haunch bones, forming a sort of basin to which the lower limbs are attached, and it is the swing of the haunch bones which carries each limb alternately forward as shown in the accompanying diagram.

TRAINING

Training should be planned to carry one comfortably over the distances, but, as in running, it is the pace and not the distance that kills. In working out for a seven miles event take plenty of good, free-striding country walks of six miles each at about five miles an hour, and pay attention to the study of form. In the second month work up to ten miles, allowing

yourself ten minutes for each mile. In the third month get on to the track and work at one to two miles, varying the pace by the introduction of speed walking sprints of fifty to a hundred yards, and alternate a finish. Try also to manage an occasional quarter mile in about 1 min. 30 secs. In this part of training build up gradually from half to three-quarter speed, and each week work in a long stroll. This stroll should also be a feature of each week's work right through the competition season. In actual racing aim at uniformity of pace, but hold enough in hand for a fast finish. You must, of course, be a good judge of pace and build up a time schedule and stick to it.

The late Sam Mussabini, who consulted often with the great professional walker, W. Cummings, drew up the following schedule as a general guide for track walkers :

	The Average Good Walker		The Champion			The Average Good Walker		The Champion	
	Mins.	Secs.	Mins.	Secs.		Mins.	Secs.	Mins.	Secs.
$\frac{1}{4}$ Mile	1	45	1	25	4 Mile	32	0	28	30
$\frac{1}{2}$ "	3	35	3	5	5 "	40	0	36	0
$\frac{3}{4}$ "	5	30	4	45	6 "	48	30	43	30
1 "	7	30	6	30	7 "	57	15	51	15
$1\frac{1}{2}$ "	11	25	10	20	8 "	66	0	59	0
2 "	15	15	13	50	9 "	75	0	67	0
3 "	23	45	21	0	10 "	84	0	75	30

PART III—The Field Events

CHAPTER XV

THE HIGH JUMP

THERE are known to me no legends of great high jumps being accomplished in the pre-historic days of athletics. Donald Walker, writing in 1834, states that "A good high leaper will clear 5 ft. ; a first-rate one 5½ ft. ; and an extraordinary one 6 ft." And yet, in 1876, when M. J. Brooks, O.U.A.C. (No. 2, Plate 1) actually did clear 6 ft. 2½ ins., the famous Scottish professional all-round athlete, Donald Dinnie, wrote to the press to prove on *a priori* grounds that such a feat was physically impossible. That Brooks did his jump is, however, proved beyond all possibility of doubt, and I am open to believe that long before the beginning of the last century feats as great had been accomplished.

The late Major R. V. Mostyn once told me that in Canada he had seen a lumber-jack in his rough clothes clear 5 ft. 8 ins., and I well remember one afternoon as a boy riding home from hunting and stopping on Redbourne Common, near St. Albans, to watch some boys jumping ; one of them in corduroys and plough boots cleared a bar at 5 ft. 4 ins. In Central Africa I have seen barefoot savages jump close on 6 ft. and heard often of a tribe in the far interior who had men said to be capable of clearing over 7 ft. And what black men are doing to-day I suppose our own white ancestors were able to achieve, when they too enjoyed the freedom of savagery.

For the rest, I am bold enough to believe we have to-day in the United Kingdom high jumpers, and indeed all classes of field events men, as strong, springy, and naturally gifted as any others the world can produce. But our men do not develop

into world's record breakers because they are not given the encouragement of competition and training facilities, and even moderately scientific instruction is extraordinarily hard to come by.

In the early sixties of the last century, when the Oxford and Cambridge Sports and the English Championships were founded, the English average of winning performances works out at approximately $5\frac{1}{2}$ ft., with 5 ft. 9 ins. the record at both meetings. At first the two Cambridge men, T. G. Little and J. H. T. Roupell had things very much their own way and in the first English Championship of 1866 shared the honours at 5 ft. 9 ins., and that record stood for five years. Two years later, R. J. C. Mitchell, a wonderful all-round athlete, was discovered in Manchester and came to London to win the English high jump, 5 ft. 8 ins. In 1870 and 1871 he set up a record which, I think, has not yet been beaten, by winning four events on one afternoon in two consecutive years.

Then M. J. Brooks and M. G. Glazebrook appeared upon the scene. In 1873 Brooks, then eighteen years of age, won the Rugby School high jump at 5 ft. 3 ins. and the long jump at 20 ft. 3 ins. His prowess dated from the opening of the school gymnasium in that year. He was absolutely fearless and would jump a high hedge or a six-barred gate and at Rugby cleared the famous "Butler's Leap," comprising a stout fence, 15 ft. of water, and a drop of 12 ft., from a very short approach run. In 1874, he went up to Oxford and produced vastly improved form by taking the Inter-University high jump at 5 ft. 10 ins., thus disposing of Mitchell's record by half-an-inch, and still further improving matters a week later at Lillie Bridge by winning his first English Championship at 5 ft. 11 ins. A sprain kept him out of competition during 1875. In 1876 he attained his twenty-first year, stood 6 ft. in height, and weighed just about 11 stone. He was cleanly built, but rather thin; he was, however, long, strong, and springy. This was his big year, for he first won the Oxford high jump at 6 ft. $0\frac{1}{8}$ in. and the long jump at 21 ft. 11 ins., then the Inter-Varsity high jump at 6 ft. $2\frac{1}{8}$ ins., which still stands as

Athletics of To-day

an Oxford and Cambridge record, and the long jump at 21 ft. 8½ ins. A few days later he took the English Championship at 6 ft.

Mr. Brooks, who is still alive, has kindly supplied me with a lot of information about early days. When he disposed of his own and Glazebrook's record the excitement was tremendous, for up to that time no one had believed that 6 ft. would ever be beaten, but nowadays we are beginning to ask ourselves if one day 7 ft. will not be reached. The jumping was from cinders on the Old Marston Ground, but there were plenty of puddles about, and Sir Montague Shearman has stated that in one of them alighted the top hat of the O.U.A.C. Honorary Treasurer, which he threw up in his enthusiasm for Brooks's great leap. A fortnight later, when the present Inter-Varsity record was made at Lillie Bridge and Brooks walked back, amidst tremendous applause, under the bar he had cleared, the weather was fair and warm and the grass take-off quite firm, but at the English Championship Meeting three days later at the same ground rain fell in torrents and the take-off was sodden and very heavy. It is noteworthy that 6 ft. was never again cleared at the Oxford and Cambridge Sports until J. D. S. Pendlebury, C.U.A.C., did exactly that height in 1927, nor was it reached in the English Championships until P. Davin, an Irishman, did 6 ft. 0½ in. in 1881.

In jumping Brooks ran straight at the bar and states that his difficulty generally lay in getting his elbow and arm over. His approach was at a pace just over a walk, and his spring was clean into the air with legs well tucked up in front. His feet he could throw over almost any height, and his body he managed to carry clear with a forward jerk, which landed him on his toes, a very necessary adjunct to style in the days when there were no sand pits to land in. It may be remarked that in 1873, Mr. Brooks represented Oxford against Cambridge and England against Scotland at Rugby football.

Judging from a very informative book of press cuttings, which has been lent to me by Mr. C. L. Lockton, who was himself no mean high jumper, there was a rapid improvement

The High Jump

187

in schoolboy performances just prior to the period of Brooks's greatness. For example, the high jump at Merchant Taylors' School in 1872 was won at 4 ft. 9 ins., but in 1875 we find L. F. E. Despard winning in the same open class at 5 ft. 5 ins. from E. W. Williams, 5 ft. 3 ins. and A. V. Despard taking the under sixteen event at 4 ft. 7 ins. At open sports meetings however, the standard appears to have been much the same as it is to-day, *i.e.*, 5 ft. 3 ins. to 5 ft. 5 ins.

Meanwhile America had begun to take an interest in the sport with the foundation of National and Inter-Collegiate Championships in 1876. The Americans were not very good at first, as is proved by the fact that H. H. Lee, Pennsylvania, took the second Inter-Collegiate title at 4 ft. 11 ins., while the lowest height that has ever won at the Oxford and Cambridge Sports is 5 ft. 4½ ins., and the lowest English Championship win is 5 ft. 2 ins. The average of winning jumps for the first eight years of Championships in America was Inter-Collegiate, 5 ft. 3 ins., and National, 5 ft. 4½ ins.

In 1887, W. Byrd-Page, of Pennsylvania University, U.S.A., believed to have modelled his style on that first used by Brooks, crossed the Atlantic, and English sportsmen received a shock, for he stood but 5 ft. 6 ins. and yet had touched the big heights. The American, however, met his match in the English Champion, G. W. Rowden, a slim, youngish-looking athlete from Teignmouth in Devon, who had cleared 5 ft. 11½ ins. the year before, and who now tied with Byrd-Page at 6 ft. The Devon man took but a short run and leapt clear over the bar, while the American, with a walk-up approach, shot his legs over straight in front of him before wriggling his body back to the perpendicular and landing almost under the bar. At Stonebridge, later that year, Byrd-Page cleared 6 ft. 3½ ins. and in 1890 Rowden did 6ft. 5¾ ins., but the A.A.A. would not accept the record owing to some doubt concerning the level of the take-off.

These two fine athletes were succeeded in the world's championship class by another "little marvel." This was Mike Sweeney, the father of the oldest form of modern, standardised

Athletics of To-day

jumping. His contemporary in the middle nineties was a tall Irishman, J. M. Ryan, of Tipperary, who jumped 6 ft. 4½ ins. Had he developed the scientific skill of the American, he might have proved the better man, but they never met, for Ryan was unable to make the journey to America with the London A.C. team in 1895, when Sweeney set the world record at 6 ft. 5½ ins., his own height being but 5 ft. 8½ ins.

Sweeney fully envisaged the fundamental principle of scientific high jumping, which other men from M. J. Brooks onwards had been groping after. Sweeney held that to achieve the maximum height possible a man must alter the position of his trunk from upright to flat (or vertical to horizontal) in its passage over the bar. This transposition, according to his theory, brought the heavy head and shoulders down to the proper centre of gravity and allowed all parts of the body to rise just high enough to clear the bar, but not a fraction of an inch higher. He admitted that his particular form called for the maximum amount of body control and accurate timing. He was a left-footed jumper and approached the bar with light, springy steps from directly in front. He used to throw his right foot straight up with his body facing the bar as he sprang from the left foot. Then the left leg was drawn up very quickly. At the end of its upward swing the right leg was turned a quarter on to its left side and was followed by the whole body turning also to the left. Then the left leg and hip were jerked up and the head and shoulders kept down to effect the lay-out. Finally, as the body fell, almost facing the bar it had cleared, the arms were thrown up and the head bent back to draw the chest away from the bar, and the jumper alighted on the left foot, from which his spring had been made. The performance was distinctly a two part jump, first the spring upwards and then a definite break when the hitch-kick, or hip-jerk, was introduced to get the body to its maximum height. Sweeney's world's record stood for twenty years and, indeed, 6 ft. 6 ins. has since only been achieved or beaten by the invention of an entirely new method—the "Western Roll," of which I shall say more presently.

The High Jump

189

Sweeney, of Irish extraction, and Ryan, were followed by the Leahys, another great Irish family. P. J. Leahy eclipsed Byrd-Page's twenty-one years old British record by jumping 6 ft. 4 $\frac{1}{2}$ ins. at Mill Street, Dublin. He, and his brother Con, who came after him, were tall, dark, cadaverous individuals, who laid out quite flat above the bar and parallel to it when going over, much as do the "Western Rollers" of to-day.

Con enjoyed an even greater career than his brother, for he was almost always safe for 6 ft. or an inch better. He won the world's championship at the intercalated Olympiad at Athens, 1906, and tied for second place with Dr. Somody, Hungary, and Georges André, France, at 6 ft. 2 ins., when H. F. Porter, U.S.A., won the Olympic high jump in 1908 at 6 ft. 3 ins. Dr. Somody, incidentally, was a fine natural jumper without a single gymnastic twist in his evolutions.

Of the phenomenal career of André I have written in Chapter XI.

In 1910 we saw the first of B. Howard Baker (Nos. 1 and 5, Plate 27) in England and Tim Carroll in Ireland.

Tim was a medium-sized, sturdily-built fellow, with a perfect oritlamme of a blazing red head and fiery blue eyes. The sight of him in competition with B. Howard Baker would always delight a Stamford Bridge crowd, than which there is none more critical. Tim, eyes and mouth set, body bent forward from the hips and pitched right up on his toes, arms stretched down stiff as two pokers with hands on a level with his knees, and creeping towards the bar from straight in front, for all the world like a cat stalking a bird, made a picture. Then came three or four quick strides, a spring, and the sudden Sweeney twist over the lath. About Baker there was nothing "dour," and I don't think I ever saw him jump without a smile on his face, but he was tremendously determined.

To see Baker start on the slant and come bounding at the bar in a series of long leaps from one great "cee-spring" leg to the other was a joy in itself. But when he won his first English Championship in 1910 at 5 ft. 8 $\frac{1}{2}$ ins. he was entirely without form, and in the next year was beaten at 6 ft. by the German,

R. Passemann, who also took the pole vault. From then on, until he finally retired from athletics, Baker was only once beaten in the English Championships, that was in 1914 when Wesley Oler, U.S.A., took the award at 6 ft. 2½ ins., winning by the odd half-inch because he could get his body out a little flatter before the under leg kick than Baker at that period of his career was able to do.

In the previous year Carroll had cleared 6 ft. 5 ins. ; the performance was passed by the Irish A.A.A. but has never been accepted as a British record.

Throughout the War Howard Baker served in the Royal Navy and sustained an injury to the ankle of his jumping leg, which, it was thought, would terminate his sporting career. But on the resumption of athletics in 1919 he won the Championship as readily as ever and showed such an improvement in style as made us hopeful for his success at the Antwerp Olympiad a year later, for he had enjoyed no luck at Stockholm in 1912. He was, however, destined to meet a very wonderful American, Richmond W. Landon, who stood 5 ft. 9¾ ins. and weighed 9 stone 6 lb. when at the age of twenty-five he created a new Olympic record of 6 ft. 4¼ ins. and, incidentally, jumped 6½ ins. higher than the top of his own head, using an adaptation of the style employed by M. F. Sweeney.

The following year brought Baker to the zenith of his career. He was now sure of always clearing 6 ft. 3 ins., and at one meeting went for 6 ft. 6 ins. Just as he was running up a more than meticulous official shouted to him to stop. He did so and burst his shoe. The trouble was that he had tied a handkerchief to the bar and the pernickety fool of an official declared that to contravene the rule that the bar must be made entirely of wood. Since then a handkerchief as a sighting mark has been legalized. Baker was to have his British record, however, for at Huddersfield on June 25th, 1921, he accomplished 6 ft. 5 ins. from a grass take-off.

Six foot three inches, or perhaps a bit more, in height and weighing best part of 14 stone, Baker was more than merely a fine high jumper. He could do any field event well, played

The High Jump

191

for England at Association football and water polo, was first-rate at cricket and tennis, and a superb dancer.

Meanwhile a startling step in the evolution of high jumping method had been made in America. There they usually think things out to the *n*th and a bit beyond it, but the "Western Roll" form of jumping, which has made 6½ ft. and over possible, was discovered purely and simply by accident.

George Horine, like B. Howard Baker, was in his early days a confirmed "scissors" jumper; and in that natural but useless style he had found his limit at 5 ft. 1 in. It seems impossible to believe, therefore, that by the principle of applied mechanics he was able to take the world's record up to 6 ft. 7 ins. in the space of two years; and yet that is what he did. In 1910, just before he entered Stanford University, California, Horine, who stood 5 ft. 11 ins., weighed 9 stone 9 lb., and was twenty years of age, found himself in a place where the jumping pit was so placed that the jumpers could only come at the bar straight in front or from the left-hand side. This did not at all suit him, as he was a left-footed jumper and so was used to running from the right, all jumpers, up to that time, being accustomed to make the spring off the foot *farthest* from the bar. Horine made the experiment of running from the left side and jumping from the left foot, *i.e.*, the foot *nearest* to the bar. It did not work at first, so he tried coming at the bar from straight in front. That did not work either, but the idea of jumping in an entirely new form from the foot nearest to the bar had got a firm hold of him, and in 1912 he again tried approaching the bar from the left-hand side. Suddenly the new action came to him, and in a week he had cleared 5 ft. 9 ins., a few days later he jumped 6 ft. 1 in., and on May 18th of the same year took the record up to 6 ft. 7 ins. By that time his weight had increased to 11 stone 8 lb.

Horine, curiously enough, was not a success at the Stockholm Olympiad in the following July, and I believe the real reason was that every one was so interested in his new method and he so willing to show it that he almost jumped himself to death before the actual competition took place. In 1914 Dr. E. E.

Beeson, of the same University and using the same style, brought Horine's record up to 6 ft. $7\frac{5}{8}$ ins. and more recently Harold M. Osborn (see Plate 24) has really brought 7 ft. in sight by clearing 6 ft. $8\frac{1}{2}$ ins. In the same year he set the Olympic record at 6 ft. 6 ins., went half an inch higher in Scotland, and equalled the A.A.A. Championship record of 6 ft. 4 ins. made by P. Léwden, France, in 1923. In 1925 he set the world's indoor record at 6 ft. $6\frac{1}{2}$ in.

Osborn, who is of medium height, thick-set and very strong, used much the same "Western Roll" form as Horine and Beeson, but seems almost to have rediscovered it on his own account. As a boy Osborn was keenly interested in athletics, but had a secret ambition to become a Marathon runner. It never entered his head that he might one day become world's record holder for both the decathlon, that severest of all athletic tests, and the running high jump. His decathlon training started in his country home, to and from which he used to run three miles each day to attend school, and where, with his two elder brothers, he staged many private athletic meetings. Their hurdles, jump standards, and vaulting poles were all fashioned from hickory cut in the home woods; they used the head of a broken maul for a shot, and they read every scrap of athletic literature they could lay their hands on.

At high school young Osborn ran a half mile in 2 mins. 13 secs., a mile in 5 mins. 7 secs., and cleared 5 ft. 3 ins. in the high jump and 20 ft. in the long jump. Then he happened to read an article in the *American Boy*, describing how Alva Richards of Utah had won the Olympic high jump at Stockholm. Boy-like, he tried to imitate Richards's style as described in the article. In reality he developed something entirely different. For Richards used to go over the bar rolled up in a ball, whereas Osborn began by pushing his feet well to the left in a real lay-out, which approximated to the Western Roll form. That was in 1917, at which time Osborn's limit in the old "scissors" style had been 5 ft. 3 ins. The new style gave him 5 ft. $7\frac{1}{2}$ ins., and then Gill, the University of Illinois coach, changed him from the straight in front approach to a run from the left side of the



PH 25

Mac Mills [N 102

THE HIGH JUMP.

H. A. SIMMONS, PUBLIC SCHOOLS RECORD HOLDER, JUMPING IN THE "EASTERN CUT-OFF" STYLE

1. The take off. 2. The high kick. 3. The hang. 4. The beginning of the turn.



Max Milis

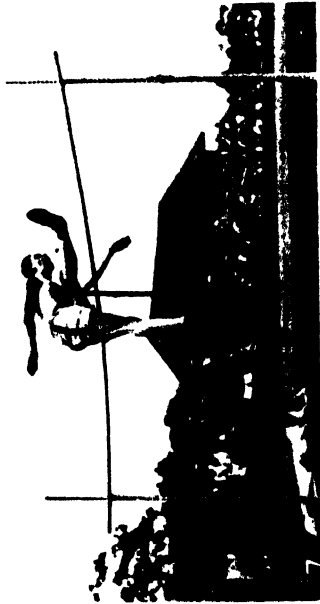

PL. 26j

THE HIGH JUMP.

THE "EASTERN CUT-OFF" STYLE, CONTINUED FROM PLATE 25.

5. Central split position over bar. 6. The lay-out. Note straightened left leg. 7. R. Landon, U.S.A., former Olympic Record holder. The pivot. Note bending, back of body. 8. P. Lewden, France, fall and body clearance.

bar, Osborn being a left-foot jumper. The alteration gave him another couple of inches straightaway, and at the University of Chicago Indoor Meet—his first big competition—he cleared 5 ft. 10 ins. for second place, and at that time he would still have been well content with the knowledge that he would one day clear 6 ft.

The following year he took up a number of events, and next spring beat 6 ft. by half an inch in California, and later went on to 6 ft. 2½ ins. In 1921 he beat 6 ft. 4 ins. ten times and only dropped below 6 ft. 3 ins. three times. In 1922 he cleared 6 ft. 6 ins., and in 1924 made the present world's record of 6 ft. 8¼ ins., as well as the decathlon record, only broken by Yrjöla, the Finn, at Amsterdam.

Osborn's training, which may be a guide to other jumpers, opened with preparatory work in the spring, comprising sprinting, hurdling, and high kicking to loosen all the muscles and the hips and knees, and pole vaulting and weight-throwing to build up the muscles of the shoulders, arms, and abdomen. In the season proper he dropped the pole vault, but kept up the other events and jumped three times a week for form at low heights which he knew himself to be capable of clearing. On Fridays he rested, and on Saturdays he entered any competition that was going, or tried himself out to see what height he could clear. He was also very keen on skipping to develop his feet and legs.

Osborn, it must be remembered, is a very robust individual and so can stand a lot of work. Dick Landon, who was subject to illness, on the other hand, once told me that after the late John J. Mack, coach to Yale University, had given him his style and grounded it right in, he needed very little training beyond a small amount of practice before meets and a great amount of walking. Baker, another robust athlete, simply bubbling over with energy, took much the same sort of practice as Osborn, but the more lightly built jumpers, like C. T. Van Geyzel, C.U.A.C., and H. A. Simmons, L.A.C., obviously cannot stand such strenuous work.

C. T. Van Geyzel, the C.U.A.C. Cingalese record holder, may,

I think, quite properly be regarded as the British successor of Howard Baker ; but H. A. Simmons, I believe, will in a few years prove himself to be a better jumper than either of them. In 1923 P. Lewden (No. 8, Plate 26), a short, slight Frenchman, raised the A.A.A. Championship record to 6 ft. 4 ins., and in 1924 C. T. Van Geysel, Ceylon, and L. F. Roberts, who had arrived at Cambridge from South Africa holding the South African High Schools record of 5 ft. 11½ ins., which was also a South African national record, put up a new Fenner's, Cambridge, ground record of 6 ft. 1¼ ins. Van Geysel then turned his attention to cricket and so did not compete at either the Olympic Games or the A.A.A. Championships, in which A. G. de L. Willis, C.U.A.C., took second place at 6 ft. 1 in., and Roberts tied for third place at 5 ft. 11 ins.

Roberts never developed anything but a natural "scissors" style, but Van Geysel, after some months at home in Ceylon, got down to the "Eastern Cut Off," which is an improvement on the Sweeney form, and in 1925 raised the Fenner's Ground record to 6 ft. 3 ins., won the Oxford and Cambridge event at 5 ft. 11½ ins., but did not compete in the championships. In 1927 he was out of the Inter-University Sports, J. D. S. Pendlebury, C.U.A.C., who went over flat on his back, winning at 6 ft., the first time that height had been reached in the Inter-Varsity Sports since 1876. Van Geysel, however, won the A.A.A. title at 6 ft. 1 in. Then he went home, but returned in 1928 to represent Great Britain at the Games. He did no good, however, at Amsterdam, owing mainly to a knee injury sustained some weeks before. At the English Championships he was beaten by an inch by C. Menard, France, who cleared 6 ft. 3 ins., and H. A. Simmons, Taunton's School, Southampton and L.A.C., was third at 6 ft. 1 in.

This boy Simmons (seen in Plates 25, 26 and 27) is a record breaker in more senses of the word than one. He made his athletic *début* at the Public Schools Championships of 1927. I remember him as a tall, very thin boy, with abnormally long legs and a high kick like a ballet dancer. I remember also that he got Harry Barclay, Honorary Secretary A.A.A., "all

The High Jump

195

hot and bothered" by the quiet persistence with which he replied "Not yet," each time the bar was raised and he was asked if he was going to commence jumping. That was a remarkable year, for G. M. Moll,* Bedford School, had earlier in the afternoon made a new "under 16" record of 5 ft. 5 ins., and was still jumping in the senior contest when Simmons disrobed himself, measured his approach, kicked a good deal more than the height of the bar, and came in at 5 ft. 4 ins. In the previous year C. E. S. Gordon, Charterhouse, had taken the record up to 5 ft. 10 ins., and that year Simmons and C. L. Napier, Sloane School, tied at 5 ft. 8 ins.

Napier had the beginnings of a style, but Simmons's action was purely "scissors," from a plain walk up with an amazing high kick. In an article of mine which appeared in *The Field* of November 17th, 1927, I criticised Simmons's form, adversely, I am afraid, and he wrote to ask what I could recommend to improve his technique. From that time onwards letters, photographs, diagrams, and sketches passed between us week by week, and on March 3rd he wrote me that he had cleared 5 ft. 9 ins. in the new style he was learning; and, as I had expected him to go back in his work, I was delighted and told Mr. Wadmore, the British Olympic team manager, that I had a boy in training who would be good enough to go to Amsterdam and would, I hoped, beat the best of our British high jumpers. In April I saw Simmons again, for the first time during a year. He carried off the Public Schools high jump with a record of 5 ft. 10½ ins. and was unlucky to bring the bar down at 6 ft. His style was now taking shape.

The Championships came in July, and he gave us 6 ft. 1 in. That made his place in the British team secure, and he broke Georges André's record, which had stood since 1908, of being the youngest athlete ever to represent any nation at the Olympic Games, for Simmons was still a schoolboy and only seventeen years of age when he went to Amsterdam in July, 1928. There he fulfilled my prophecy and did indeed prove

* On March 28th, 1929, at Bedford School, Moll cleared 5ft. 11½ins.; he was 17½ years old, and stood 5ft. 9in.

himself the best of the British competitors by clearing 6 ft. 1½ ins., beating C. E. S. Gordon, C. T. Van Geyzel, and G. Turner, who had won the N.C.A.A. Championship at 6 ft. At the British Empire v. U.S.A. Match on August 11th, 1928, Simmons and Gordon both cleared 6 ft.

We come now to the question of styles. The old, natural "scissors" style is bad, because it lifts the heavy head and shoulders at least a foot and a half above the centre of gravity, with which they should be level in transit over the bar. It contravenes also the modern axiom that a high jumper should always land upon the same foot from which he took off. The "Western Roll" (Plate 24) is, I believe, the most perfect form of jumping yet discovered, because it is the one that conforms most nearly to the mechanical principles upon which the theory of high jumping is based, in that the athlete jumping in this style gets a more complete "lay out" than in any other and actually employs less foot-pounds of work in achieving his object, because his take-off and landing are closer to the bar than in other forms; and, his body being parallel to the bar in transit, he occupies less time in passing over than he would do if he effected the clearance with his body at right-angles to the bar, as do the "Sweeney" and "Eastern Cut Off" jumpers. In addition, the whole jump is continuous and smooth, whereas the other forms call for great concentration upon the timing and carrying out of the pivotal movement, or "hitch-kick." It is, in the final issue, a simple form, and that, after all, should be the determining factor in assessing the value of any style.

I would here pause to suggest that the high jumper should work to diagrams and charts, just as the distance man trains to a time schedule. This can of course be the more easily done if the take-off is from cinders. The sketches accompanying this chapter illustrate the type of diagram that Simmons and I used when we were building up his style.

Fig. 13 shows merely the three standard types of approach run. It is important, in training, to mark out your proper approach run with a line scratched on cinders or a white-wash line on grass. Get a friend to keep an eye on you and with him

study your footwork closely. Each style calls for an approach run of 36 to 40 feet ; do not be satisfied to guess your run, but measure it with a tape from take-off straight back to starting point. If you do this and also set out the proper angle of your approach you will have gone a long way towards achieving success. You must of course adjust the starting point, length of run, number of strides, and position of take-off to meet your own case, but stick to the angle of approach and distance of take-off given in the diagram as closely as possible.

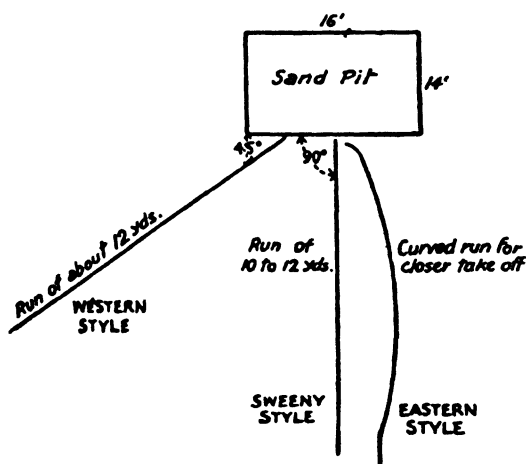

Three Standard Approach Runs

FIG. 13

“ Western Roll ” Style.—Now look at the diagram in Fig. 14. The parallelogram ABCD represents the take-off and landing zone. ER is the exact distance at which you take-off from a point at right angles to the bar and immediately beneath it. Osborn’s point E was $3\frac{1}{2}$ ft. from point R. Note that his left foot was partly pointed towards the bar, and that he got right down on to the left heel for his take-off. The line EP indicates the direction of the right leg kick, slightly outwards, foot towards the middle of the bar, point M, toes pointing straight upwards.

Osborn allowed 24 ft. between point E, the take-off, and his first check mark, which he hit with his left foot, and 12 ft. more between his check mark and his starting point. The run was a trot from starting point to check mark, the take-off being reached thence in four springy, powerful strides. He crouched a little on the last stride and got considerable force into the right leg kick. At the same time he swung the left arm up and snapped the left leg close to the right; the left arm was then dropped down, as shown in Picture No. 1, Plate 24. In

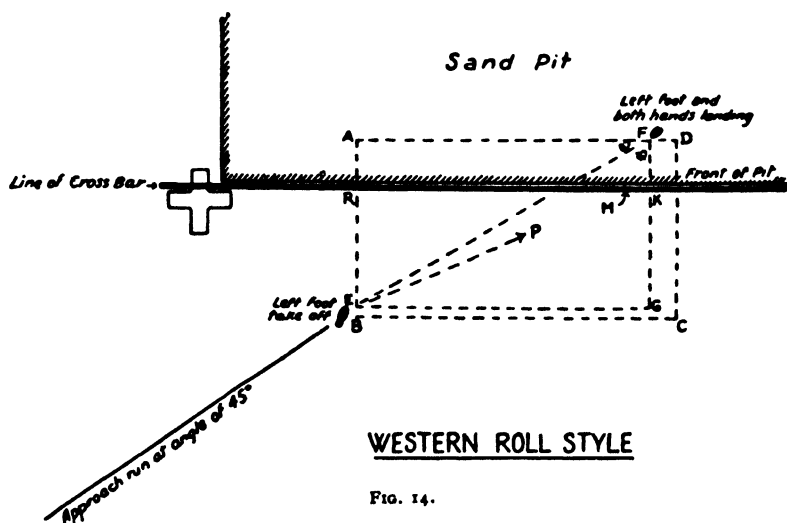

the next movement the whole body was straightened with a jerk and the right leg brought down to help to raise the body which has assumed a perfectly flat lay-out above and parallel to the bar (see Picture No. 2, Plate 24). It will be noticed that the left (jumping) leg has been well bent at the knee and tucked in under the right; some "Western Roll" jumpers complete the forward roll as Osborn is doing in the third picture, by dropping the left arm, turning the head to the left, and bringing the left heel right back behind the right buttock, and at the same time pointing the toes of the right foot;

others get both legs out perfectly straight in crossing the bar and this perhaps is the better way, because it is the simpler method.

The jumper lands at point F, Fig. 14, about 1 or 2 ft. from point K, a spot directly under the bar, and comes down on his left foot (pointed back to face his approach run), and his hands, which help to absorb the shock of landing. EF is the distance he covers in effecting clearance, approximately 10 ft. from take-off to landing, and EFG the triangulation of his total effort.

Make for yourself a number of charts, similar to the one I have drawn, and fill in the measurements after each jump. You will then see readily how you are shaping.

“ Eastern Cut-Off ” Style.—We come now to the consideration of a style entirely different from the “ Western Roll,” but which is yet based upon the same fundamental principle of getting everything down to the level of the centre of gravity. The high jump illustrations (Plates 25, 26 and 27) together with the diagram in Fig. 15 (p. 200), should make it easy for the reader to follow the evolutions of the Eastern form. The approach run is made from straight in front of the bar (see Fig. 13). It can be made either in the old Sweeney method, when the take-off spot G in Fig. 15 will be approximately $4\frac{1}{2}$ ft. in front of a spot directly under the crossbar, or on a slight curve, as in the more modern Eastern method, when G will be about 4 ft. from K, the point immediately under the bar. The Eastern approach is to be preferred, as it brings the jumper nearer to his work.

About 24 ft. back from the take-off put down a check mark, and 12 ft. back of that mark the point from which the approach run is to begin. Assuming that the spring is to be made from the left foot, the man who runs straight reaches his check mark in three strides, the man approaching on a curve will probably use four strides to reach his check mark, which is hit with the left (jumping) foot. In either case four more long springy strides should bring the left foot on to the take-off spot; length of run and number of strides will, however, vary with the physique and condition of the individual.

Athletics of To-day

In Fig. 15 the parallelogram ABCD represents the zone of take-off and landing. G is the point of left foot take-off and E the position of left foot landing. Note that the left foot points along the line GH in the take-off position so that it is at an angle of 45° to the bar, but in landing at E is pointing along the line EF, thus finishing up at right angles to the bar—two different angles of foot placement from those employed in the "Western Roll" style (see Fig. 14). GK represents the ver-

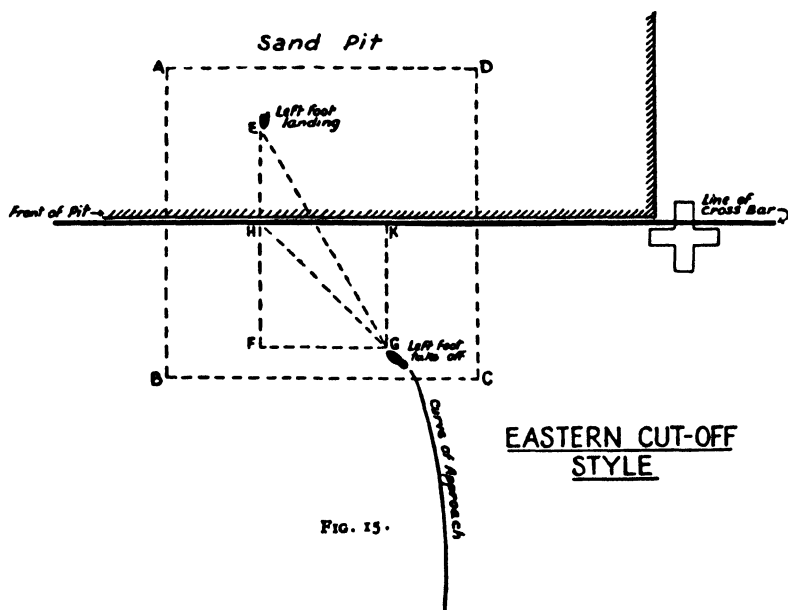

tical distance from take-off to line of bar, and EH vertical distance from landing to bar line. GEF is the triangle of total effort and GE the distance covered from take-off to landing, approximately 8 ft. The closer the perpendicular EF can be brought to the perpendicular KG the better will be the jump performed, since the more quickly and completely the pivotal action above the bar is performed (see Picture 7, Plate 26—R. Landon, U.S.A.) the further will the left-foot landing, E, move in the direction of the left-foot take-off perpendicular GK.

The High Jump

201

We come now to an interesting sequence of pictures, mostly of H. A. Simmons. No. 1, Plate 25 emphasises the gathering together of the jumper and the slight crouch which precedes the right leg high-kick and left leg spring. Note the direction of the left foot, which has been allowed to sink right on to the heel, and the working of the muscles of the left thigh, and how Simmons's eyes are watching the sighting mark affixed to the bar. No. 2 shows the full extension of the left leg with the spring coming from the very tips of the toes and the vigorous straight-leg kick of the right leg. This, combined with spring and arm action, contrives to raise the jumper's centre of gravity to the level of the bar. In No. 3 the foot, at the end of a perfectly straight leg, is reaching its maximum height, for a 6 ft. clearance, of just over 8 ft. Note that the body turn to the left has not yet begun and the left leg is still being allowed to "hang" loosely. No. 4 shows the beginning of the body turn to the left and a slight dropping of the right leg as the knee comes above the bar. The left leg is now in position, with foot pointing to the left, for a strong, sharp kick upwards. In No. 5, Plate 26, the division between the legs is centralized over the crossbar, which the right leg has crossed completely, the left arm has been dropped, and the trunk is working down to the lay-out position (transposition movement from vertical to horizontal is taking place). The upward kick with left leg is just commencing. No. 6 shows the completion of the lay-out (everything working down to the centre of gravity) with the lower hip apparently about to hit the bar. Note particularly the way in which the left leg is held perfectly straight as it is whipped over the bar. No. 7 of R. Landon, U.S.A., shows the left leg secondary kick and the twist of the shoulders, which together lift the buttocks over the bar. The left leg (still straight from hip to foot) is now kicked straight back until it comes level with the right leg. The right leg then takes up the body rotating movement the moment the left leg, its work finished, comes level with it. No. 8, of Pierre Lewden, France, shows how the right leg resumes its work with a hard kick back and up as the left foot drops towards the sand-pit, and the back

Athletics of To-day

is hollowed, the head bent back and the arms flung up to draw the chest and chin away from the bar. Lewden is, in reality, a right-foot jumper, but the negative was reversed in making the picture to preserve the sequence action of a left-foot jumper. Note two points in all these pictures: (1) The clever balance work of the arms, and (2) the way in which Simmons has kept his eyes, throughout the whole evolution, fixed upon the sighting mark attached to the crossbar.

I have been at some pains throughout this chapter to point out how experimentalists, like Horine and Osborn, have been able, by the perfection of mechanical skill, to turn a natural ability to clear just over 5 ft. by sheer spring, into world's record performances of 6 ft. 7 ins. and 6 ft. 8½ ins. respectively. But I do not know that the last word has been said even yet. To me it seems apparent that so far the attention of those who have sought to build up the mechanics of high jumping has been centred—and successfully so—upon the question of bringing all parts of the body down to the centre of gravity at a certain point in the parabola of effort.

The "effort" expended by a boy of Simmons's weight, which we will take at 140 lb., in clearing even a 5 ft. practice jump will probably surprise most people, but can be calculated as follows:

$$\text{Kinetic energy} = \frac{MV^2}{2G} = \frac{140 \times 18^2}{64} = 709 \text{ foot-lb.}$$

So far he has expended this amount of energy in raising his hips to the height of the bar and has gained whatever greater height he has cleared by bringing all parts of his body down to the centre of gravity. We are now trying to find a means whereby he may raise his centre of gravity to a higher point than he has achieved so far. Reference to Picture 2, Plate 27, will show the experiment which is being tried. In this picture Simmons is kicking a bar set at 8 ft. 1¼ ins., thereby developing kick and spring combined, and has brought his head to a height of 7 ft. 9 ins., with his centre of gravity above the 6 ft. line, and the more the kick and spring are developed together the higher must

the centre of gravity be lifted above the ground. Had B. Howard Baker (Picture 1, Plate 27) got this higher foot elevation, instead of the flat kick shown, he might have cleared a height even more surprising than his record of 6 ft. 5 ins. There is no reason why the hips should not go still higher, on Professor A. V. Hill's proposition that "it is possible for an object to pass over a bar while its centre of gravity passes beneath," in which connection he quotes a rope running over a pulley as an obvious example.

Should it be possible for Simmons to manœuvre his body in a certain way, following upon his extreme high kick, he may well prove the practical truth of Professor Hill's proposition. Picture No. 4, Plate 27, shows a strained position in one of the suppling exercises Simmons uses. The outer ankle bone of his left (jumping) leg is resting on the back of a seat 3 ft. in height. The left leg is straight and at right angles to the straight right leg; the body is square, otherwise both hands could not be resting on the ground. If he can attain this position in the air, when unsupported, both hips will be lifted above the bar at the same time, and they will be the only part of the body above the bar at that time; the left leg will be straight out as shown and the right leg, upper body, head and arms below the level of the bar. Working by mechanics, if one part of the body goes down another point must come up. The dropping of the right leg and bending down of the trunk should raise the hips, and the left leg swing would supplement the action, while the strengthening of the back and abdominal muscles should allow of the trunk being whipped up again fast enough to clear the bar with the chest.

Picture No. 3, Plate 27, shows yet another of Simmons's suppling exercises. On one point I must warn the reader. It takes but four-fifths of a second (approximately) to clear a bar set at 5 ft.; it will be obvious, therefore, that there is every necessity to jump most often only at such heights as one can be sure of clearing and to work for perfection in each part of the jump separately before attempting to co-ordinate them all together in the rhythmic effort of the whole jump.

CHAPTER XVI

THE LONG JUMP

THE long jump is one of the standard field events in Great Britain, and it gave us our youngest champion in C. L. Lockton, Merchant Taylors' School and L.A.C. At Merchant Taylors' Sports in 1869 he competed in the "under 14" class and won the 100 yards in 13 secs., 440 yards in 67 secs., high jump 4 ft. 1 in., and long jump 13 ft. 5 ins. It may interest the reader to know that at that same meeting W. G. Grace, the famous cricketer, won the Strangers' Quarter Mile race by 2 yards from W. F. Eaton, the Civil Service champion, in 53 secs., whereas the English Championship of the same year was won by the great E. J. Colbeck, L.A.C., in 53½ secs.

In 1873 Lockton, at the age of sixteen years, won the English Championship at 19 ft. 4 ins., and at the L.A.C. Summer Meeting cleared 21 ft. 4 ins., beating the L.A.C. jumper Lucas (20 ft. 10 ins.) and Ward of Mote Park C.C. (20 ft. 7 ins.). Before he left school this sturdily built lad, whom I have mentioned in other chapters, and whose portrait appears in Plate 1, cleared 22 ft. He was English Long Jump Champion again in 1875 (20 ft. 10½ ins.), 1879 (22 ft. 1½ ins.) and 1880 (22 ft. 7 ins.). He was a first-class hurdler and sprinter too, and very nearly in the first flight of high jumpers, for in 1877, when G. W. Blathwayt, C.U.A.C., became English Champion at 5 ft. 6 ins., Lockton cleared 5 ft. 7 ins. at the Civil Service Sports.

F. H. Gooch, O.U.A.C., won the Oxford and Cambridge long jump of 1864 and 1865 at under 19 ft., but no one, except A. G. Grant-Asher, O.U.A.C., who won at 19 ft. 10 ins. in 1885, has since failed to beat 20 ft. In the English Cham-

pionships, however, 20 ft. was never reached from 1866 until 1871, when E. J. Davis, C.U.A.C., tied with R. J. C. Mitchell, Manchester A.C., at 20 ft. 4 ins. This is the same Mitchell who acquired championships also in the pole vault, high jump and shot put.

The following year Davis, a small, lightly-built athlete, startled the athletic world with a leap of 22 ft. 7 ins., but in 1874 was beaten at the Irish Civil Service Sports by J. Lane, who stood 5 ft. 8 ins., and weighed 11 stone 1 lb., who established a new world's record of 23 ft. 1½ ins.

The American Championships started in 1876, I. Frazier winning the National title at 17 ft. 4 ins., and H. L. Willoughby, Pennsylvania, the Inter-Collegiate, at 18 ft. 3½ ins. In 1890 A. F. Copland, Manhattan A.C., added a quarter-inch to Lane's world's record with his American Championship leap, and in 1893 C. S. Reber, Pastime A.C., became U.S.A. Champion at 23 ft. 4½ ins., while Charles Fry, the famous Oxford all-round sportsman, who had raised the world's record to 23 ft. 5 ins. in the previous year, now took it up to 23 ft. 6½ ins.

Long jumping performances were now improving very fast, through the introduction of the wood take-off board, the Scotch and Irish element being mainly predominant in Great Britain. In 1897 the late W. J. M. Newburn, Ireland, won the A.A.A. title and added half an inch to Fry's record and later beat 24 ft. He was a veritable giant of a man, well over 6 ft. 3 ins., and heavy in proportion. His physique may be judged by the fact that fifteen years later he won the Irish 56 lb. weight slinging championship. It is interesting to note that 24 ft. was never reached in the English Championships until 1928, in which year H. de Boer, Holland, cleared 24 ft. 2½ ins.

At the American Championships 1920, Sol Butler cleared 24 ft. 8 ins., Ed. Gourdin doing 23 ft. 7¾ ins. the next year, since when H. de Hart Hubbard has remained champion, never clearing less than 24 ft. and three times beating 25 ft. All three are short, sturdily-built negroes.

Athletics of To-day

Contemporary with Newburn were the two Americans, Meyer Prinstein, Syracuse University, and Alva Kranzlein, Pennsylvania, who between 1898 and 1900, jumped respectively 24 ft. 7 $\frac{1}{4}$ ins. and 24 ft. 4 $\frac{1}{2}$ ins.

In 1901 a tall, thin Irishman, Pat O'Connor, was remarkably unlucky in not achieving the coveted 25 ft. mark, for he cleared 24 ft. 11 $\frac{3}{4}$ ins. for a new world's record at Dublin on August 5th that year. Equally unlucky was the twenty-five-year-old American, Albert Gutterson, a fine athlete who stood 6 ft. 1 in. and weighed just under 13 stone when he won the Olympic title of 1912 at 24 ft. 11 $\frac{1}{2}$ ins.

With two men so remarkably close to a new and much hoped for record, people waited for it to be reached almost any day, but they had to go on waiting until July 23rd, 1921, when the Harvard negro, Ed. Gourdin, first beat H. M. Abrahams, C.U.A.C., in the 100 yards sprint in 10 $\frac{1}{2}$ secs. and then beat him again in the long jump with a leap of 25 ft. 3 ins. Sol Butler was said to have beaten 25 ft. in practice the year before, but in his first jump at the 1920 Olympiad he pulled a muscle, so I never saw him at his best and fully extended, although he had shaped remarkably well at the training ground where I often watched him at work.

De Hart Hubbard, a regular little "pinch o' dynamite" athlete if ever I saw one, was born in Cincinnati, Ohio, on November 25th, 1903, and started competing in his second year at Walnut Hills High School. Before he entered the University of Michigan in the autumn of 1921, he had, at seventeen years of age, done 100 yards in 10 secs., 23 ft. 6 ins. for the long jump, and 45 ft. in the hop, step and jump. At eighteen years of age he won Freshmen's events in the long jump 24 ft. 6 ins., and 120 yards hurdles in 15 $\frac{1}{2}$ secs. In the following year he pulled out 25 ft. 2 ins. in the long jump, 48 ft. 10 $\frac{1}{2}$ ins. in the hop, step and jump, and returned 15 secs. flat for the high hurdles.

With three such marvellous black men in the field, who made a strange little stride in the air at the top of the jump, we were beginning to ask ourselves if negroes were the

The Long Jump

207

only men who really could long jump, and we were all pretty eager, when we arrived in Paris for the 1924 Games, to get a sight of Hubbard and Gourdin. The result was disappointing. Hubbard's leg went back on him, and in the eliminating trials he started with a no jump, hit 23 ft. 4 ins. with his second, and no jumped again with his third, but got into the final, which he won at 24 ft. 6 ins., not bad for a man with a game leg. Gourdin produced 23 ft. $7\frac{1}{2}$ ins. in the trials, and improved it to 23 ft. $10\frac{1}{2}$ ins. in the final.

The real surprise of the 1924 Olympiad was produced by a tall, well-built, white American, who added swing to the black men's mid-air stride. Robert Legendre had won the U.S.A. Inter-Collegiate long jump at 23 ft. $7\frac{1}{8}$ ins., and the Inter-Collegiate Pentathlon in 1922, but was not considered good enough to represent America in the long jump; he did, however, come to Paris in the Pentathlon quartette. And in that contest took the world's long jump record up to 25 ft. 6 ins. I was standing close to the pit when he thus exceeded by nearly 2 ft. any performance he had ever done before, and I have never in my life seen a long jumper rise so high nor get such an amazing "lift." His body was right back from the hips when he started his "hitch-kick," and he whipped his trunk up from the waist like lightning when he brought his forward leg back. It was at Paris too that I first saw S. Cator, a coal black Haitian, who also beat 25 ft. a year or so later.

De Hart Hubbard, meanwhile, had gone back to the States, very sick at his ill-luck, but not grouching, only quietly determined to get back to form. This he accomplished, and on June 13th, 1925, at Chicago raised the world's record to 25 ft. $10\frac{7}{8}$ ins., and there it still stands, for although he cleared actually 26 ft. 2 ins. in 1928, that record was not accepted, on the grounds that the level of the take-off board was one inch higher than the surface of the landing pit!

In England the art of long jumping has fallen on very lean times, and we have never had an athlete who was up to the present world's championship standard, although H. M. Abrahams was a fine long jumper as well as a great sprinter.

At Antwerp in 1920 when Wm. Petterson, Sweden, won at 23 ft. $5\frac{1}{2}$ ins., W. Hunter, Great Britain, was 13th at 21 ft. $0\frac{3}{4}$ in., and Abrahams 20th at 19 ft. $10\frac{1}{4}$ ins. At Paris, however, C. E. MacIntosh, O.U.A.C., who had won the Public Schools title in 1922 at 20 ft. 6 ins., and the Oxford and Cambridge event in 1924 at 23 ft. 4 ins., gained 6th place for Great Britain with a jump of 22 ft. 5 ins. At Amsterdam, 1928, our representatives were H. J. Cohen, C.U.A.C., and R. W. Revans, University of London; the former succeeded in just beating 22 ft. De Hart Hubbard could not find his form. Ed. Ham, a white American, won at 25 ft. $4\frac{3}{4}$ ins., with S. Cator, Haiti, second at 24 ft. $10\frac{1}{8}$ ins.

Ham is a truly remarkable athlete, and when, on August 11th, 1928, in the British Empire v. U.S.A. match, he set up a new British record of 25 ft. 1 in., that was the eighth consecutive competition in which he had succeeded in beating 25 ft. A. Bates, U.S.A., was third at 24 ft. 8 ins., and Hubbard fourth at 24 ft. 6 ins.

The Empire has, however, produced some notable long jumpers in H. M. Abrahams, England, 24 ft. $2\frac{1}{2}$ ins.; C. D. Bricker, Canada, 1912 Olympiad, second, 23 ft. 8 ins.; Dr. R. St J. Honner, Australia, A.A.A. Champion, 1925, 23 ft. $11\frac{1}{2}$ ins., and 1926, 23 ft. 8 ins.; S. J. M. Atkinson, South Africa, 24 ft. $1\frac{1}{4}$ ins., and W. N. Harrison, Australia, 22 ft. $10\frac{1}{2}$ ins., both at the British Empire and U.S.A. match, 1928.

There is, however, hope for us in the prowess of our Public School boys, for there are several of the present generation who bid fair to become second Locktons. J. S. Moll, Bedford School, at eleven years of age cleared 13 ft. 4 ins. in 1924, an even more remarkable performance than that of Lockton in 1869, and in 1928 a sixteen years old Dover School boy, F. W. Goodbody, did 20 ft. 1 in. and a week later 20 ft. 9 ins., while J. Simpson, Oundle, in April of that year, put up a new Public Schools record of 22 ft. $3\frac{1}{2}$ ins. When all is said and done, however, it simply amounts to this: there is in England as good material as anywhere else in the world, but the boys get next



PI 27]

Max Mills and Sport and General [O 208

THE HIGH JUMP.

1. B. Howard Baker, Great Britain; the flat kick. 2. H. A. Simmons, Great Britain, using high kick exercise to raise centre of gravity. 3 One of Simmons's suppling exercises. 4. Hip flexibility exercise used by Simmons. 5 B. Howard-Baker, Great Britain, British Record holder, 6 ft. 5 in.



THE LONG JUMP.

1. Correct take-off action at sprinting angle. 2. R. W. Revans (Great Britain): the hang. 3. R. W. Revans: the kick. 4. V. B. V. Powell, former Public Schools Record holder: the lunge position before the kick, which some jumpers use.

to nothing in the way of teaching or training while at school, and outside the Universities there is no encouragement given them to go on competing after they leave. In Sweden, where matters are managed differently, the schoolboys' record stands at 22 ft. 9 $\frac{3}{4}$ ins. and the national record, made by a Swede, is 24 ft. 6 ins. The Norwegian national record is 24 ft. 6 $\frac{1}{2}$ ins., with Germany's record at 25 ft. 1 $\frac{3}{8}$ ins. and that of Holland 23 ft. 11 $\frac{1}{2}$ ins.

There is indeed reasonable ground for doubting if we as a nation are very much ahead in long jumping of our forefathers of a hundred years ago, since Donald Walker published a book in 1834, in which he said "On level ground 20 ft. is a first-rate leap, 21 ft. is extraordinary, and 22 ft. is very rarely accomplished," and if you add to that "by English club jumpers of to-day," it just about sums up the state of things in England.

The first adjunct to successful long jumping is, of course, speed. We have seen that De Hart Hubbard, the world's record holder, could sprint his "100" in evens, while Reggie Walker, who won the Olympic 100 Metres in 1908, could nearly always clear 22 ft. in the long jump without the slightest pretension to actual skill; or, again, Alva Kranzlein, the first American to beat 24 ft., was also former holder of the world's 120 yards hurdles record of 15 $\frac{1}{2}$ secs.

To prove the case for speed, take the following mathematical calculations:

Example.—A, B, and C, each weighing 140 lb., jump 22 ft., but approach the take-off board at different rates of speed—A at 40 yards in 5 secs., B at 40 yards in 6 secs., and C at 40 yards in 7 secs., speeds representing velocities of 24, 20 and 17.14 feet per second respectively. To clear 22 ft. the jumper's impulse must generate an initial velocity of 26.5 ft. per second. Hence there is an increase of 2.5 ft. per second for A, 6.5 ft. per second for B, and 9.34 ft. per second for C.

The formula by which the impulse generated may be found is as follows:

$$P = m (u - v)$$

Athletics of To-day

where m = mass, or weight of the jumper's body, which is 140 lb. If this is worked out the reader will find that the impulse of the force required is :

A for 24 ft. per second, 350 units of impulse.

B for 20 ft. per second, 910 units of impulse.

C for 17.14 ft. per second, 1,320 units of impulse.

This proves of course that the faster a man runs to his take-off the less units of impulse will he need for making his jump, or, conversely, if C could approach at the speed of A and still generate his own previous increase on the first speed, he would easily win the contest. In other words, the greater the speed of the approach run the more units of energy the athlete will have at his command to put into the jump.

Not every one, however, is blessed equally with speed and spring, wherefore long jumpers fall into two categories. There is the sprinter type, relying on speed for distance, and the jumping type, which relies mainly upon natural jumping powers to achieve the desired result. It seems rather obvious to say that jumpers must strive after speed and the sprinting type seek to develop its springing powers, but such is the case ; for it is a just combination of the two qualities that brings the big results.

The approach run as a rule supplies about seventy-five per cent. of the long jumper's difficulties. For even where the run has become standardized at say 92, 110 or 115 feet, and the athlete has developed an absolutely regular stride, it will be found that the run varies according to the physical condition of the athlete, the state of track and weather, and the direction of the wind. As we have seen, De Hart Hubbard's leg gave him trouble at Paris in 1924, and that was why he recorded two no-jumps in three trials. It was also, I imagine, due consideration of all these circumstances which led Lawson Robertson, the American chief Olympic coach, to recommend the development of a mechanical approach, pacing back an even number of strides from the take-off to get the starting spot in each competition. This, however, calls for considerable sighting judgment, such as I mentioned in Chapter XI on the

The Long Jump

Low Hurdles, so that one may adjust the stride to the take-off five or six strides before it is reached.

The advice of the late Michael Murphy, former American Olympic coach, was, "Walk back 12 paces, or 25 to 40 ft. (from the take-off board, of course). This will bring the foot upon the take-off in six strides."

✓ Ernest Hjertberg, the Swedish and Dutch Olympic coach, advised, "Three marks—one 7 ft. from the take-off, one 17 ft., and one 27 ft. The foot with which the leap is made is placed upon the 27 ft. line, and, if the run does not work out right, the marks should be altered until the foot hits the board. It is the jumping foot that hits all three marks, and, if it falls short of the 17 ft. mark, then the 27 ft. mark should be moved towards the take-off by as much as the foot fell short of the

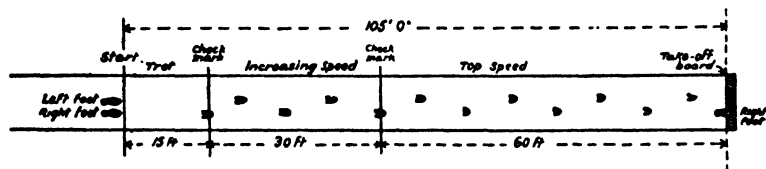

FIG. 16.

The Approach Run.

17 ft. or middle mark. The distance between the 17 ft. and 27 ft. marks is now fixed and any adjustment to bring the jumping foot on to the take-off board will necessitate moving both the 17 ft. and 27 ft. marks a distance back or forward corresponding to the distance the jumping foot fell short of, or overstepped, the take-off board."

✓ Alec Nelson, the Cambridge University coach, recommends a 30 yards approach run with a check mark 20 yards back from the take-off board, the jumping foot striking both the check mark and board.

✓ T. E. Jones, Physical Director, University of Wisconsin, U.S.A., recommends the athlete to "ascertain the length of the running stride. Establish a check mark six strides back of the take-off board (No. 1). Establish a second check mark twelve strides back of the take-off board."

Athletics of To-day

The diagram in Fig. 16 gives a suggestion, first for framing a run-up, and, secondly, it shows the type of diagrammatical chart every athlete should keep. He will of course fill in the distances at which he finds his check marks and starting-point fall, should fill in his known striding capacity, and check the imprints of his spiked shoes on the cinder path by measurement and compare his actual run-up with the ideal of striding shown on his personal chart. In this way any irregularity in length of strides can be very quickly detected and adjusted. Regularity and evenness in striding are essential.

The question of take-off is the next matter to be considered. The reader is referred back to Chapter II on The Sprints, and Fig. 3, page 52. From this he will see that the true sprinting

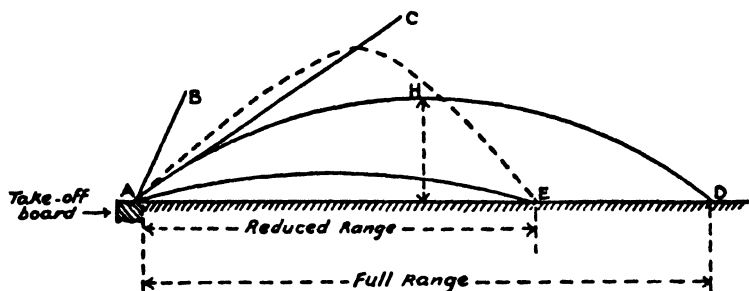

FIG. 17.

angle is one of seventy-five degrees. This is the proper body angle (a different thing from the angle of take-off or flight) at the moment the spring is made. The jumper has no means of checking his own body angle and must therefore get a friend to watch him. Two posts can be set up beside the take-off board, one vertical and the other inclined towards the pit at an angle of seventy-five degrees. If the observer places himself at right angles to the vertical post he can then easily judge the angle of the body's inclination. In addition photographs should be taken frequently and be compared with a chart, such as is shown in Fig. 3, page 52. That the true sprinting angle can be preserved at the moment of take-off is shown by Picture I, Plate 28, of the long jump illustrations. Notice

also the straight-ahead foot placement with the spring starting from the heel, the high pick-up of the knee of the free leg, and the continuation of the arm action of the sprinter.

Now let us examine the diagram in Fig. 17. The point A indicates the wooden joist, sunk flush with the surface of the ground, from which the spring is made. AB shows the correct sprint angle of 75 degrees formed between the line of the body AB and the ground line AD at the instant of take-off. The line AC indicates the correct direction of take-off and with the ground line AD forms an angle of 45 degrees and this, in its turn, produces the true parabola of flight AHD, which is the path of the jumper's centre of gravity. If, however, the body is projected from the take-off at an angle greater or less than 45 degrees the range will be reduced as shown at E. H is the maximum height attained in the true 45 degree parabola of flight, and this height can be calculated for any given distance of jump.

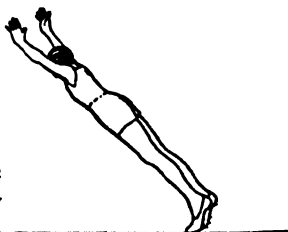

FIG. 18.

In order not to complicate the issue by the introduction of speed velocity and increased acceleration, let us assume that a man weighing 168 lb. is going to jump 10 ft. from a standing take-off. (See picture in Fig. 18.) In this case the body will be at full stretch (standing jump only) as shown in the accompanying sketch. He will leave the board with a velocity of 17.8 ft. per second and his initial horizontal and vertical velocities will both be 12.6 ft. per second, the compressed force exerted being 93.45 lb. and the kinetic energy 831.6 ft.-lb.* If he jumps at the correct angle of 45 degrees, according to all laws of dynamics, the highest point in the parabola of flight will be reached at 2 ft. 6 ins. midway between take-off and landing.

During the first part of the jump from A to H (Fig. 17) the

* *Force* is that which changes, or tends to change, the state of rest or uniform motion of a body. *Kinetic energy* is the energy due to the motion of a body, and is increased by the amount of work the body can perform against the impressed forces before its velocity is destroyed.

athlete is fighting to combat the resistance due to the attraction of gravity. After the point H is passed gravity will assist the athlete to increase the length of his jump, provided his own centre of gravity continues to follow the true path of the parabola. The problem that all athletes have long been seeking to solve is that of preventing the heavy upper part of the body from coming forward as momentum is lost and so disposing the weight forward and thus forcing the legs to earth earlier than they should reach the sand-pit.

It has been stated, and truly so, I think, that no explosive "hitch-kick," running step, or any other unsupported mid-air movement of any nature whatsoever can add to the velocity of the body once it has been projected from the take-off board by the impulse generated in the speed of the run-up and the power of the spring. And yet athletes have proved the practicability of prolonging the flight of the body from take-off to landing through the introduction into the jump of certain mid-air evolutions. This prolongation of flight depends entirely upon the timing and the proper execution of the "hitch-kick," or running step in mid-air, at the highest point in the parabola of flight.

At the point H in the curve AD (Fig. 17) the force of the initial impulse is facing defeat, and from that point to the point of landing the force of gravity begins to overcome the athlete's powers of resistance. If at that stage he allows his weight to go forward his legs will be forced down and he will land in the sand-pit somewhere between E and D, instead of getting full value for his speed and spring which should carry him on to D. The first part of the trick is summed up in the one word "hang." This same "hang" of the push-off leg has, as we know, already played an important part in both the high jump and high hurdles.

The long jumper, then, is at top speed as he approaches the take-off board on which he stamps the jumping foot down hard and flat and concentrates all his will-power into getting height into the jump as his centre of gravity passes over his jumping leg (see No. 1, Plate 28). Full use is made of the arms and

shoulders to help to lift the body into the air. The free knee is drawn up, but once the jumping foot has executed the spring, with a full extension of the whole limb, it is allowed to hang, or trail. R. W. Revans shows this action well in Picture No. 2, Plate 28, but is already gathering himself for the "hitch-kick," in which movement the right arm will be snapped forward with the trailing left leg, when the right leg will go back (as seen in No. 3) before being again brought up level with the left leg. Note how Revans has readjusted his body position during the "hitch-kick." The forward movement of the left leg and right arm and the backward kick of the right leg are all well shown also by Alzieu, a French jumper, in Picture No. 3, Plate 29.

No. 4, Plate 28 shows V. B. V. Powell, the Cambridge Blue and English International, who in 1923 raised the Public Schools long jump record to 21 ft. 9½ ins. He had a most efficient "hitch-kick" and in the picture is seen reaching his highest point at which his kick was given effect. Compare the forward bend of his body with the uprightness of trunk shown by Revans, Alzieu and Ham. Unless Powell had straightened himself out from the position shown, the weight of his body must have forced his feet very quickly to earth. The pictures of Alzieu and Revans seem to me to prove clearly how well the "hitch-kick" serves to get the body back to the vertical, so that the weight is kept back of the centre of gravity, instead of forcing it down.

Picture No. 1, Plate 29, is of P. O'Connor, former world's record holder, who did not use the "hitch-kick," but simply drew the knees up towards the chin and trusted to his initial velocity to carry him "sailing" through the air. The weight is disposed forward, but had he known the modern "hitch-kick" method I think he might well have exceeded 26 ft., instead of just failing to reach 25 ft. No. 2, Plate 29 shows Ed. Ham, U.S.A., Olympic Champion and British Record holder (25 ft. 1 in.) in about the same stage of the jump as O'Connor, but the American, of course, is using the "kick." The "hitch-kick" is just finishing; his balance is perfect, and

his right arm and both legs preserve the illusion that he is "running"; his left hand is getting position to aid the leg shoot that completes the air phase of the jump. In the next movement the right knee will come up to the level of the left, and the arms will be swung down as the feet are thrust as far and as strongly forward as possible. The ability to master these last two phases of the action will add from nine to eighteen inches on to the total measurement of the jump. All the "about to land" action is well shown in No. 4, Plate 29, a picture of Ham breaking British record.

The heels now take the sand as shown in the accompanying sketch A (Fig. 19), and, to prevent himself from sitting down backwards the jumper must force the body down over his thighs as shown in B (Fig. 19). Notice particularly how the legs are "breaking" at the knees. In the next movement, shown in C (Fig. 19) the arms are being swung from rear to front to help to lift the body forward, so that the athlete, who has landed first on his heels, will transfer his weight on to his hands and knees. If a man shoots, or rolls over, forward on landing, it is a sure sign that he is using up, wastefully, on the ground, the remains of the energy generated by the run and take-off impulse, which he should have expended in his passage through the air.

TRAINING

The long jumper's training divides itself, properly, into two parts (1) getting speed, and (2) getting jumping technique. It is quite sufficient to practise long jumping every other day, with a rest on Friday and Sunday; the other intermediate days should be devoted to sprinting. Each day, however, there should be practised skipping, leg swinging, high-kicking, hopping on take-off foot, heel and toe lifting exercises, and exercises for the calves and ankles, and especially exercises for the muscles of the abdomen, back, and shoulders, and body building and stretching exercises. Notice in Picture No. 4, Plate 28, V. B. V. Powell's splendidly developed legs, and in

Picture No. 2, Plate 29, the tremendous muscles of Ed. Ham's left upper arm.

In practice and competition the run-up should always be measured with a tape, not "stepped," and try two runs through always before you jump to assure yourself that you are going to hit the board. If the track is heavy, shorten the run a bit. If it is harder than you have been accustomed to, then lengthen the run-up. Similarly, if the wind is with you lengthen the run; if it is against you shorten the distance of your approach, but remember to give your run more length with the wind at the back than the amount by which you shorten it if the wind is blowing in your face. Do plenty of training with a short run and aim to drive the knee of the free leg up strongly so that you may get good height into the jump; at the same time let the other leg "hang" as shown by Revans (No. 2, Plate 28). Work for speed, proper body angle at take-off and good elevation, and the distance will come of itself. I am not in favour of training over a string fixed across the pit to give the jumper elevation. Its presence usually destroys the "hang" of the jumping leg. Practise letting the jumping leg hang until the highest point in flight is reached, then whip it up and forward smoothly but strongly as Revans (No. 3, Plate 28) and Alzieu (No. 3, Plate 29) are doing. In the "hitch-kick" have the arms working in concert with the legs and force the body back.

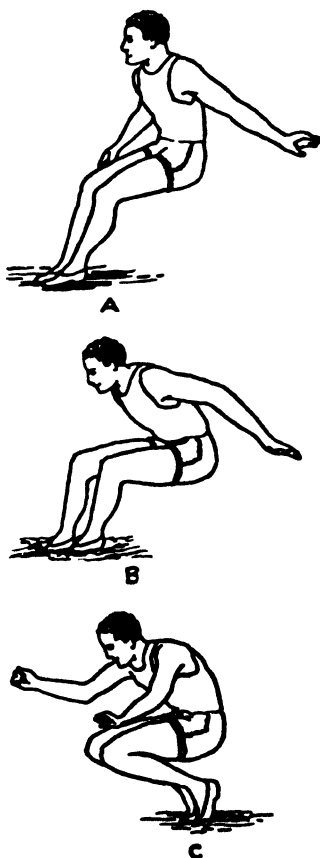

FIG. 19.

The long jumper should train with the sprinters on his non-jumping days (see Chapter II on The Sprints), and should go an occasional quarter mile at three-quarters speed. Practice in high jumping and high hurdling will improve the spring and general suppleness, and javelin and discus throwing with the hand opposite to the jumping foot will increase bodily strength and control and improve the sense of rhythm and timing.

When training to perfect the run-up always work at top-speed ; otherwise you will find your stride varying and your take-off falling all wrong. In perfecting the take-off, however, and in jumping for height and form you can work best at about half-running speed.

CHAPTER XVII

THE HOP, STEP, AND JUMP

THE history of the hop, step, and jump is practically Olympic history. This event has been in the American National Championship programme since 1893 and has been practised in Ireland, and possibly Scandinavia, from time immemorial, but has never found favour with the Universities on either side of the Atlantic, nor was it practised in England until the Amateur Field Events Association promoted the first national championship in 1911. This was won by an Irishman, M. D. Dineen, at 41 ft. 6 ins. The hop, step, and jump has, however, always figured in the programme at the Olympic Games since J. B. Connolly, U.S.A., took the title with a triple effort of 45 ft. at the first of the modern Olympiads in 1896 at Athens.

Connolly, an Irish-American, seems to have specialised in this one event, but Myer Prinstein, U.S.A., who took the Olympic honours in 1900 and 1904 at just over 47 ft., was a fine all-round athlete, although he had little chance as a hop, step, and jumper in the States where a championship was instituted in 1893, dropped in 1894, and not resumed until 1906. He took National and Inter-Collegiate long jump championships, however, at over 23½ ft.

At the intercalated series of Games held at Athens in 1906, eighteen athletes took part in the hop, step, and jump. Prinstein had a game ankle at the time and reached only some 41 ft. C. Leahy was expected to win but had trouble in hitting the take-off and was beaten by 3¾ ins. by his fellow Irishman, P. O'Connor, the world's long jump record holder (No. 2, Plate 30), who cleared 46 ft. 2¼ ins. Both men were excellent high and long jumpers (see preceding chapters).

Athletics of To-day

By 1908 two great Irish brothers had made their appearance. Dan Ahearne, the elder, had emigrated to America, but Tim stayed in Ireland. Dan did not come over to the Olympic Games of London, but Tim represented Great Britain. He was then twenty-two years of age, stood 5 ft. 7 ins., and stripped at 9 stone. In 1907 he won the Gaelic A.A. long jump at 23 ft. 2½ ins. and hop, step, and jump at 48 ft. 4 ins., and in 1908 the Irish A.A.A. long jump at 23 ft. 1½ ins.

I have seldom seen a man so nervous as Tim Ahearne appeared to be in the stadium at Shepherd's Bush, where there were twenty competitors, but he put in a wonderful winning effort of 48 ft. 11¼ ins., only 3 inches less than the world's amateur record made by W. McManus at Cootamundra, N.S.W., 1887. Ahearne is seen making his record jump in No. 3, Plate 31. That was the only British success in the 1908 field events, although T. G. MacDonald, who was second to Ahearne at 48 ft. 5¼ ins., was a Canadian. He had never done anything like that before and was a great contrast to Ahearne, for the Canadian at twenty-six years of age stood 6 ft. 1 in. and weighed well over 12 stone.

The following year Dan Ahearne improved the twenty-two years' old record to 50 ft. 11 ins. in America. And that record was destined to stand for yet another fifteen years. Meanwhile the Continental nations, especially the Scandinavians, were showing marked improvement, but England none. But D. Shanahan, at Limerick, 1908, made a new British record of 50 ft. 0½ in. In 1904, M. D. Dineen, Ireland, had won the British Olympic Trial at 44 ft. 4½ ins. In the British Trials of 1912 he tied with S. S. Abrahams, C.U.A.C., at 43 ft. 10 ins. Tim Ahearne meantime had joined his brother in America and was lost to us. At Stockholm there were a great many more competitors. Of them G. Lindblom, Sweden, proved the best at 48 ft. 5 ins., other Swedes finishing second and third, and a Norwegian fourth, the twelfth man, incidentally, beating 45 ft.

During the War period the Scandinavians continued to improve and, in fact, developed a great liking for this "odd"

The Hop, Step, and Jump

221

event, and at Antwerp in 1920, V. Tuulos, a short, stocky Finn, took the Olympic title at 47 ft. $7\frac{1}{2}$ ins., with Folk Jansson, a tall, lean Swede, an inch behind him, Swedes being third and fourth, and Dan Ahearne sixth at 46 ft. $2\frac{3}{4}$ ins. The English representatives, big B. Howard Baker (see Chapter XV), and little tiny C. E. Lively, jumped respectively 44 ft. $10\frac{1}{4}$ ins. and 43 ft. $1\frac{3}{4}$ ins. Tuulos followed up his Olympic success by winning the hop, step, and jump at the Gothenburg Exhibition in 1923 at 50 ft. $5\frac{1}{10}$ ins., Folk Jansson (No. 1, Plate 30) doing 48 ft. $2\frac{3}{4}$ ins. for second place. Meanwhile, England had at last produced a man in J. Odde, Polytechnic A.C., to beat 46 ft. and three more in J. Higginson, Northern Champion, and D. G. Slack and H. A. Langley, Midland Champions, who had done better than 45 ft.

The 1924 Olympic competition at Paris was remarkable in every way. None of the Englishmen jumped up to form, Odde producing the best effort of 43 ft. $11\frac{3}{4}$ ins., nor could Dan Ahearne (U.S.A.) or De Hart Hubbard, the negro long jumper, who had been touching 50 ft., go anywhere near world's record form. L. Bruneto, a heavy 6 ft. Argentinian, with his first jump cleared 50 ft. $7\frac{1}{4}$ ins. for a new Olympic record, V. Tuulos, Finland, 50 ft. 5 ins., V. J. Rainio, Finland, 49 ft. $2\frac{1}{8}$ ins. and Folk Jansson, Sweden, 49 ft. $1\frac{1}{2}$ ins., also eclipsing the previous Olympic best. With his very last jump, however, A. W. ("Nick") Winter, a regular devil-may-care Australian, came down the path at tremendous speed, rose cleanly from the board, and gave us a new world's record of 50 ft. $11\frac{3}{8}$ ins. Bruneto tried to beat this and indeed seemed to me to get more than 52 ft., but lost his jump through fouling. M. Oda, Japan (No. 1, Plate 31), sixth at 46 ft. 9 ins., was at that time only a schoolboy. But his feat marked the first entry of Japan into international athletics as a serious competitor for Olympic honours.

Before 1928 came round and we prepared to go to Amsterdam Tuulos had again cleared 50 ft., Bruneto was credited with 51 ft. odd, Oda had won the Far Eastern Championship at 50 ft. $4\frac{9}{16}$ ins., and at the English Championships, H. de Boer,

Athletics of To-day

Holland (No. 2, Plate 31), with a jump of 50 ft. 9 ins., had eclipsed the British record made by D. Shanahan in 1908, while Levi Casey had raised the U.S.A. Championship record to 49 ft. 4 $\frac{1}{2}$ ins. In Great Britain alone there was not the slightest sign of improvement to be seen, and no competitions, other than those at the national and the three district championships, were held.

The meeting of such a wealth of talent was expected to produce a new world's record at Amsterdam. In point of fact the extraordinarily high Paris standard was not again reached. Mikio Oda sent the Japanese flag to the mast-head for the first time in Olympic history with a triple jump of 49 ft. 10 $\frac{1}{8}$ ins., beating the American, Casey (49 ft. 9 ins.), the Finn, Tuulos (49 ft. 7 ins.), Nambu, Japan (49 ft. 2 $\frac{3}{4}$ ins.), Toulikoura, Finland (48 ft. 2 $\frac{3}{4}$ ins.) and Jaervinen, Finland (48 ft. 1 in.). Neither Winter nor De Boer could find anything like their proper form.

The hop, step, and jump is so closely related to the long jump that the reader who wishes to take it up should study Chapter XVI (The Long Jump) very carefully and train on the principles therein laid down. To his long jumping technique he must add the ability to take three giant strides of the greatest possible length. Despite the prowess of Bruneto and De Boer, both tall, heavily built men, there is no doubt that short, sturdy men, with very strong legs, like Ville Tuulos and Mikio Oda, make the best hop, step, and jumpers. Winter had the advantage of medium height, strong legs, and a very light body. The legs of the hop, step, and jumper must be even stronger than those of his brother, the long jumper, because a tremendous strain is imposed upon the knee joints on landing on solid ground after the hop and the step.

Although this advice apparently contravenes something I have just said, the athlete is warned that each of the three progressive movements must be a "jump" and not really a "step" at all. The initial approach speed is mainly responsible for the distance to be cleared, and the athlete should strive in each of the three jumps to force his body up and forward

The Hop, Step, and Jump

223

without striving to reach out too far with his legs. At each landing the heel must strike the ground first, whence the momentum passes forward, with an "ankling" movement, to the ball of the foot, the next impulse coming finally from the toes themselves.

The run-up and take-off for the hop are, in all particulars, exactly as described in the preceding chapter for the long jump. The hop, however, must not be made too high, since one has to land on the heel of the same foot from which the spring was made, and the knee will go if one comes down too heavily and from too great a height.

The step abides more closely by its name. If it is made too much of a jump the athlete will overreach himself and have nothing left for the final jump effort. The step should not be too high, nor at the full range one might reach if it were the final effort. A glance at the accompanying sketch, Fig. 20, will show that after the step has commenced the take-off leg and the whole corresponding side of the body are allowed to sag, or "hang," while the shoulders are kept square to the front. This trailing of the back (take-off) leg is accomplished by an easy side-ways relaxation of the abdomen, but it calls for considerable muscle control and can be achieved only after much painstaking practice.



FIG. 20.

The jump, which is the last of the three actions, calls for an "all-out" effort. Every ounce of determination and conserved energy should go into the attempt to get a collected take-off with a proper forward body-lean (as shown in No. 1, Plate 28), followed by a flight at an angle of 45° to the highest point of elevation (as shown in No. 1, Plate 31, Mikio Oda, Japan, present Olympic champion). The details of the jump phase of the hop, step, and jump may be learned from Chapter XVI (The Long Jump), and if the "hitch kick" can be introduced so much the better.

If you are accustomed to taking-off from the right foot for an ordinary long jump try making the hop from the right foot, land on the right foot again, and make the step forward on to

Athletics of To-day

the left foot, and from the left foot take off for the jump. Experimentation, however, may prove that it is best for you, personally, to start the hop from the left foot. This you must determine for yourself. The diagram given in Fig. 21 shows angles of take-off, parabola of flight, and range.

In the hop, AB, the take-off angle formed between the lines AE and AB is one of 40 degrees (see also No. 1, Plate 30). The highest point in the parabola AHB is found to be 4 ft. 2 ins., and the range of the hop AB is 18 ft.

In the step, BC, the take-off angle formed between the lines BF and BC is 25 degrees. The highest point in the parabola BHC is at 1 ft. 9 ins., and the range BC is 12 ft.

In the jump, CD, the take-off angle formed between the lines CG and CD is the true long jump angle of 45 degrees, the

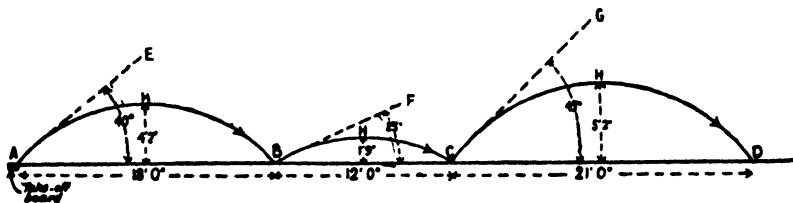

FIG. 21.

highest point in the parabola CHD is approximately 5 ft. and the range CD is 21 ft.

The diagrams and calculations, which are only approximately correct, are based upon my observation of A. W. Winter's world's record hop, step, and jump made at Paris in 1924. The diagram is important as it shows the way the triple effort is broken up into its three component parts and shows also the conservation of energy in the hop and step actions. The whole hop, step, and jump will now be summarised for the benefit of the novice.

The run-up is measured, regularised, and made at top-speed, as described for the long jump. The take-off is also as described, except that the jumper does not put quite all his force into the hop, and his take-off angle is 40 degrees instead of 45 degrees. The take-off leg is allowed to hang until the highest



1. P. 291. *Sport and General*

4

THE LONG JUMP.

(P. 224)

1. P. O'Connor, Great Britain, former World Record holder, showing the sail flight. 2. J. Hill, U.S.A., British Record holder, the hitch kick is finishing and force is being gathered for the leg. Foot shown in No. 1. 3. Albin France, middle stage of hitch kick. 4. J. Hill, U.S.A., showing final hitch to landing.

point in flight is reached (see No. 1, Plate 30, of Folk Jansson), when it passes the left and comes to the front (see No. 2, Plate 30, P. O'Connor, at the top of the rise), foot low and toes turned upwards for the landing on the heel, *i.e.*, jump from the right foot and land on the right heel to complete the hop. No. 3, Plate 30, shows the Japanese athlete, Nambu, about to land, but he has jumped from the left foot.

The weight is kept well over the right leg, which rises on the toes for the step. As the left leg comes forward with toes up to make the step, the right arm is swung forward and up and the left arm down and back. At the same time the body is forced forward. The right leg and side are allowed to drag, as already described on page 223, and shown in Fig. 20. Just before the left heel comes down to complete the step, the right arm is swung down and back to the level of its shoulder behind. As the jumper comes through from the heel to the ball of the left foot, from which the jump is to be made, the right arm is swung down and forward and comes level with the left arm just in rear of the buttocks as the body rises on to the toes of the left foot. The body goes forward to the true sprinting and jumping angle of 75 degrees so that the take-off (flight) angle may be at 45 degrees. The right leg comes through with a high knee pick-up, the left leg is fully straightened in the spring and the arms are flung up and forward to help to lift the body. As the body rises the left leg is allowed to hang until the highest point in flight is reached. Oda displays these points admirably in No. 1, Plate 31. The left leg then catches up the right and the "hitch-kick," shoot-finish, and "break" landing, as described in Chapter XVI (The Long Jump) follow in sequence. In No. 2, Plate 31, De Boer, Holland, shows the beginning of the shoot action, and T. Ahearne, No. 3, Plate 31, portrays its finish to perfection.

In training concentrate on style and co-ordination; try to get height into the jump effort, and you will find that distance in the whole triple effort comes naturally. Except for practising the run-up, work at half speed and half power. Work first for a total distance of 30 ft. and increase gradually until

you reach your maximum. Learn to carry out the whole evolution without any break between the hop and the step, or the step and the jump. The whole action must be rhythmic, continuous, and cumulative from start to finish. Do not jump all out more than once a week, and then try only three jumps at first, to be increased to six full jumps once a week when you are in competition condition.



Pl. 31]

THE HOP, STEP, AND JUMP.—THE JUMP.

1. M. Oda, Japan, Olympic Champion, 1928. Correct rising form in take-off after the step. 2. H. De Bort, Holland, British Record holder. Preparing for the shoot. 3. T. Alcazar, Ireland, Olympic Champion, 1908. Completing the landing shoot.



Sport and General. [Q 226

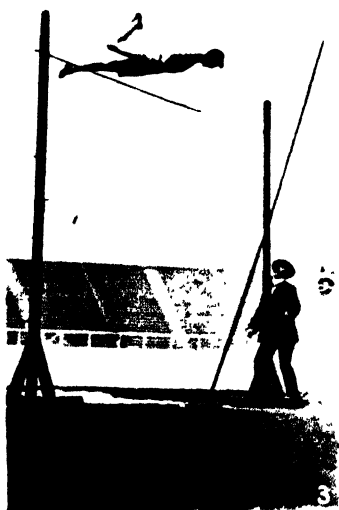
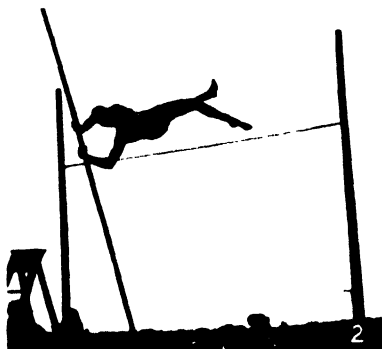
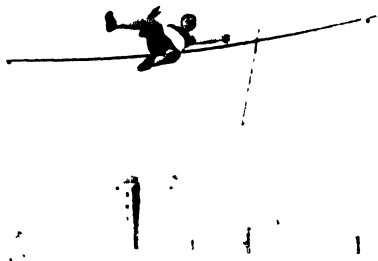

Pl. 32]

Step and General 1Q 227

THE POLE VAULT

1. F. Gonder, France, showing bad finish action. 2. B. Soderstrom, Sweden; an early attempt at the kick reverse. 3. E. Archibald, Canada, showing a good lay-out of the earlier "flat" type. 4. Frank Foss, U.S.A., making a World's Record at Antwerp, 1920.

CHAPTER XVIII

THE POLE VAULT

THE sport of pole vaulting lays no claim to classical antiquity, but probably derives from a natural means of passing over dykes and brooks. Pole vaulting for height, as we know it to-day, has for its object the clearance of a bar supported by pegs on uprights placed not less than 12 ft. apart. It is a purely competitive sport nowadays, but one of the most thrilling and graceful of all athletic events, either to practise or witness. There is something in the swift sprint to the take-off, the well timed planting of the pole-point in the slideway, the smooth leg swing, the strong pull upon muscular arms, and the final soaring over the crossbar by sheer physical cleverness which gives the onlooker and athlete alike a keener pleasure than any other sport can provide. And yet pole vaulting has not prospered in England. The game calls for coolness, dogged determination, sporting skill, and courage above the ordinary, all of which are qualities dear to the British people, and yet we have still to produce our really great pole vaulter. When he does appear the honours will fall thick and fast upon him.

We started off well enough, for the first English Championship, 1866, was won by J. Wheeler, City A.M.A.C. at 10 ft., and two years later that great all-round athlete, R. J. C. Mitchell, Manchester A.C., who in two subsequent successive years won four titles in one afternoon, took the record up to 10 ft. 6½ ins., a height not too frequently reached in English competition to-day. In America, on the other hand, where championships began in 1877, W. Pryor, University of Columbia, took the first Inter-Collegiate title at 7 ft. 4 ins. and G. McNichol, Scottish-American A.C., the National Championship at 9 ft. 7 ins.

Athletics of To-day

In 1879, J. Van Houten, another member of the Scottish-American A.C., became American Champion at 10 ft. 4 $\frac{3}{4}$ ins. He is mentioned especially, because he used much the same style as is employed by the record breakers of to-day, except that he knew nothing of the "hand shift," or vertical lift, and some of the other finer points of technique which have since developed. He was, however, a very light weight, and, as he needed only a light pole, was able to get his hands close together and thus got the advantage of a double instead of a single arm pull.

Unlike the case of A. C. M. Croome's hurdling, referred to in Chapter X, the Americans, usually so quick to grasp any possibility of improved technique, saw nothing particularly meritorious in Van Houten's method. In 1883, he was defeated by that great athlete, H. H. Baxter, N.Y.A.C., who four years later took the record up to 11 ft. 5 ins. After that defeat Van Houten was seen in competition no more, and for best part of fifteen years his style also was lost sight of. I do not believe, however, that any good thing can be entirely lost, and in 1898, R. G. Clapp, of Yale, re-introduced the style, which only the old hands, who had known Van Houten, remembered, and Clapp raised the record yet again to 11 ft. 10 $\frac{1}{2}$ ins. In the years between, men had been vaulting with the hands widely separated and thumbs turned outwards, so that the lower hand had no pulling power, but merely used its grasp of the pole as a prop to the rising body.

In England much the same "method" was in vogue, and no one succeeded in beating 11 ft. in the first fourteen championship years. But in 1874, E. Woodburn, of the Ulverston Cricket Club, came south and improved Mitchell's championship record by half-an-inch. From that day onwards the lads of Ulverston might be seen any summer evening after their day's work vaulting among the cinder heaps of the Lancashire town. Elsewhere, I fancy, the event was pretty well confined to sports meetings in country places. From old newspaper files one learns that on August 9th, 1873, one Woody vaulted 9 ft. 6 ins. at Alexandra Park Sports; in 1875, at Nuneaton,

The Pole Vault

229

S. Ratcliffe, Ashby F.C., did 10 ft. 1 in., and at Worthing, J. G. Graveley cleared 8 ft. 6 ins. In 1876 at Market Harborough, H. W. Strachan, L.A.C., who had won the English title at 10 ft. 1 in. apparently took a prize, but no height is given, and in the Civil Service Sports of 1878 he won again at 10 ft. 6 ins., beating by 4 ins. his brother, E. A. Strachan, of the 108th Regiment, better known to later generations as the Royal Inniskilling Fusiliers.

Such keen practice and competition as was going on in Ulverston was bound, of course, to produce results, and in 1881, Tom Ray, a well, but heavily, built young man, acquired the English title and raised the record to 11 ft. 3 ins. The reign of H. H. Baxter as best pole vaulter in the world was over. Ray held the English title from 1881 to 1888, except in 1883, when he let it go by default, and he raised the world's record to 11 ft. 6½ ins. In 1887 he went to America and there carried all before him. In 1888, however, he had to be content to share the A.A.A. Championship honours with his fellow townsman, E. L. Stones, at 11 ft. 0½ in. The following year reveals Stones at the top of his form. He took the American Championship at 10 ft., the English title at 11 ft. 1¾ ins. and at Southport raised the world's record to 11 ft. 7 ins.

Ray and Stones were followed by R. D. Dickinson, of Windermere, but whether he used the peculiar style of the Ulverstonians I cannot say. He held the A.A.A. title five times (once jointly with R. Watson, of Bardsea), raised the championship record to 11 ft. 5¼ ins., and on July 4th, 1891, at Kidderminster created a world's record of 11 ft. 9 ins. This, as we have seen, stood as world's best until Clapp went an inch and a half higher in 1898, and it actually remained the British native record until L. T. Bond, C.U.A.C., cleared 11 ft. 10¼ ins. in the A.A.A. Southern Championships at Oxford in 1928.

The method employed by the Ulverston men was unique, and for years the world's record holders came from that small town. Their poles were of ash or hickory, long and heavy, and shod at the lower end with a tripod of iron, forming a three-inch triangle. The weight of the pole necessitated a wide separation of the

hands and a slow run-up. At the end of the approach run the tripod was planted some 3 ft. in front of the crossbar. The athlete then allowed his body to swing up and began to climb. The upper hand was shifted a foot up the pole and the lower hand brought up to it. The climbing continued until the pole had passed the vertical position. As it began to fall forward the athlete drew up his knees and went over the bar in a sitting position, a last backward push preventing the pole from following through to remove the bar.

The Ulverston style obtained until 1889. The American athletes contended that the performances of Ray and Stones were nothing but acrobatic balancing feats, requiring neither strength nor endurance, and a new rule was passed prohibiting the athlete from shifting the grip of the upper hand and from placing the lower hand above the upper hand after the feet have left the ground. About this time too several men suffered death by impalement, through their wooden poles snapping transversely, and the pole vault began to disappear from the programmes of British school sports.

The American athletes, meanwhile, had adopted the use of light poles of female bamboo, bound between the joints with medical strapping, the general use of which has contributed in no small measure to the marvellous heights now obtained, since the lightness of such poles allows the athlete to get his hands together for a strong, double-arm pull. The tripod has vanished, the lower end of the pole being now fitted with a wooden plug which is jabbed into a slideway, such as may be seen in Fig. 22 (page 237). Another advantage of the light pole is that it allows the athlete to run much faster, while keeping his shoulders square to the front.

The introduction—or should one say the rediscovery?—of Van Houten's style by R. G. Clapp set the ball of record breaking rolling; 12 ft. was in sight and in 1904 N. Dole, U.S.A., beat it by $1\frac{3}{10}$ ins. Six years went by with the record gradually creeping up, and L. S. Scott, U.S.A., had reached 12 ft. $10\frac{7}{8}$ ins. by 1910; then, in 1912, M. S. Wright cleared 13 ft. $2\frac{1}{4}$ ins., and the age-old question, which has been asked

about every field events record, "Is another level foot possible?" was asked again, but was not to be answered for another fifteen years.

Meantime other nations were becoming efficient, and by 1906, when the intermediate series of Games took place at Athens, France was able to find the world's champion in F. Gonder (No. 1, Plate 32), who cleared 11 ft. 6 ins., and had beaten 12 ft. previously, while B. Söderstrom (No. 2, Plate 32), second at 11 ft. 1 $\frac{3}{4}$ ins., came from Sweden. E. Glover, U.S.A., third at 11 ft., was the only competitor who still used the old-fashioned heavy wood pole, all the Continentals preferring the safer and more pliant bamboo. Gonder, who was a small, light man, vaulted with the lower hand reversed wrongly and went over flat on his back, as shown in No. 1, Plate 32. Söderstrom, on the contrary, used the correct grip and had a neat reverse kick, as seen in No. 2, Plate 32, but the hand stand position, or "jack-knife" clearance, had not at that time been invented. Gonder had won the A.A.A. title, 1905, at 10 ft. 7 ins., and Söderstrom came over to win in 1907 at 10 ft. 6 ins.

For the 1908 Games, Canada sent to England a very good man, E. B. Archibald (No. 3, Plate 32). He raised championship record to 12 ft., but was beaten at the Games by a couple of Americans, who went 2 inches higher. From the scientific point of view it is interesting to note that E. T. Cook, who tied for first place with A. C. Gilbert, was nineteen years of age, weighed 10 stone 6 lb. and stood 5 ft. 10 $\frac{1}{2}$ ins. Gilbert's particulars were twenty-four years old, 10 stone 5 lb., 5 ft. 7 ins., and Archibald twenty-five years, 12 stone 7 lb., 6 ft. Great Britain was unable to find a single representative for this event and was unrepresented again at Stockholm, 1912, and at Antwerp, 1920.

The pole vault at Antwerp I shall remember for many a day. Four Americans, three Swedes, and two Danes qualified for the final by clearing 12 ft., but when it was called on, the rain was coming down in torrents. The men moved about miserably, wrapped in overcoats and rugs, and with their poles protected

from the rain with towels. The cinder path was sodden and had to be re-rolled between every vault, and yet Frank Foss, U.S.A. (No. 4, Plate 32), using the comparatively new "jack-knife" clearance to perfection, won the contest at 12 ft. 5 $\frac{1}{2}$ ins., then upset Olympic record with a vault of 13 ft. 1 $\frac{1}{2}$ ins., after which he achieved a world's record of 13 ft. 5 ins. He was a short, sturdily built man with fine legs and tremendous shoulder strength.

The next year we heard rumours of a wonderful Scandinavian schoolboy, and in 1922 I went over to Norway and met him. At the Bristol Hotel in Christiania—as the capital was then called—I ran across Frithof Dale, who invited me to go down to Copenhagen for the Landskamp—an annual Triangular International between Norway, Sweden, and Denmark—as an honorary member of the Norwegian team. Needless to say, I jumped at the chance and that was how I came first to meet Charles Hoff (see Plate 33). He was a tall, beautifully proportioned youth, nearly 6 ft. 3 ins. in height, and, I should say, well over 11 stone, and an artist by profession. He told me that he had invented a new vertical lift to effect clearance, which would, he thought, cut the "jack-knife" right out.

"I shall," he said, "leave the pole and soar upwards like a bird. You will see what happens."

"Right, my lad," thought I, "we shall see, but I doubt if you'll be in a state to understand anything." For, frankly, I thought he'd break his neck.

We had two pretty good days in Copenhagen before the match, but the Sunday afternoon, when we went out to the stadium for the sports, was a soaker. Hoff looked like a music-hall turn in a long flowered dressing-gown and carrying an umbrella. He started off, however, by winning the long jump for Norway at 23 ft. 1 in., half a foot ahead of the 1920 Olympic champion, "Kalmar" Pettersen, Sweden. The pole vault followed, and I believe he failed twice at every height until he had won at somewhere round about 12 ft. 3 ins. from Henry Petersen, Denmark, who had tied for second place in the 1920 Games. Hoff was, with difficulty, persuaded to try to beat his

own Scandinavian record of 13 ft. 2½ ins., but did so to oblige. At the first attempt he simply soared over 13 ft. 4 ins. The bar was then raised to 13 ft. 6½ ins., but he was not a bit keen on going for the world's record, as he had still another event in which he was due to represent Norway. At last he was persuaded and at the first attempt went over with plenty to spare, as the accompanying picture (No. 3, Plate 33), taken at the time, proves. After that he ended up the afternoon by finishing second in the hop, step, and jump at 46 ft. 9 ins. to Folk Jansson, Sweden, who cleared 47 ft. 1 in. In the following year I was again with him at Gothenburg, when he further increased the world's record to 13 ft. 9¾ ins., and he again increased it at Abo, Finland, in 1925 to 13 ft. 11¾ ins. This actual vault is shown in No. 1, Plate 33.

Meantime he had struck a patch of real bad luck. A vault of 14 ft. and Olympic laurels were in sight, and then, early in 1924, he broke his ankle. Pole vaulting in Paris was out of the question, but he ran finely for his country in the 400 metres, going through to the Olympic semi-final stage, but having to be almost carried from the track after each heat. We both took a good look at the American schoolboys, Lee Barnes and Glen Graham, who broke level in the pole vault at 12 ft. 11¼ ins. Great youngsters, both of them, but we thought Barnes the more likely to develop into a world beater. We were much taken too with the style of the young Canadian, V. Pickard, also a schoolboy, who went to 12 ft. 5½ ins.

The spring of 1926 found Hoff right back in form and making a new indoor world's record of 13 ft. 8¼ ins. in the States. From America he wrote me that he had seen a lad who was going to break all previous records and would certainly be the first athlete ever to clear 14 ft. Sabin W. Carr, the youngster of whom he wrote, had in 1924 made a vault of 12 ft. 7 ins. as a schoolboy, was an amazingly good gymnast, and had hit a style of his own, mid-way between the jack-knife, favoured by Foss, and Hoff's vertical lift. He was a Yale sophomore when Hoff first saw him, but by February, 1927, he had beaten Hoff's indoor record by one inch. At Philadelphia on May 27th, 1927,

Athletics of To-day

Carr fulfilled Hoff's prediction by clearing exactly 14 ft. In that competition Lee Barnes got over the same height and was well clear of the bar, but in falling tipped off the lath with his fingers. Later on Carr vaulted 14 ft. 1 in. for a new indoor record, and Lee Barnes is said to have done 14 ft. 2½ ins., but of this I have no official confirmation.

At the 1924 Games in Paris A. R. Spearow, of Portland, Oregon, U.S.A., was placed sixth at 12 ft. 3¾ ins., although he had tied in the A.A.U. Championship of 1922 with Ed. Knourek at 13 ft. After the Games, Spearow crossed over to Japan, and at Tokio was credited with a vault of 13 ft. 10¼ ins. This record never went on the books, but whatever his performance was his form certainly set the Japanese training with a new zest.

The first Far Eastern Championship Games had been held in 1920, in which year Japan sent to Antwerp a few athletes who did their best, but who did not cut much ice. What one admired most was the pluck of the imperturbable little men. What no one realized was their immense determination to make good and their extraordinary genius for athletics. Spearow, I think, inspired them, and in 1927 V. Nagazawa took the Far Eastern title at 12 ft. 0¼ in., and in 1928, when the Japanese Olympic Team came to Europe, there arrived also a Waseda University Team which took on the Achilles Club at Stamford Bridge on July 10th, and made the Blues fully extend themselves to win. At that meeting the Waseda men, H. Kasahara and S. Nishida, tied for first place in the pole vault at 12 ft. 10½ ins., L. T. Bond, the Cambridge Blue, claiming 11 ft. 10 ins. And, at Amsterdam, Nakazawa completely surpassed anything he had done before by vaulting 12 ft. 9½ ins. for sixth place. Sabin W. Carr, who won, put up a new Olympic record of 13 ft. 9½ ins., W. Droegmuller, U.S.A., did 13 ft. 5½ ins., and V. Pickard, Canada, Lee Barnes, and C. McGinnes, U.S.A., all went over safely at 12 ft. 11¼ ins. Finally, at the British Empire v. U.S.A. Match in London on August 11th, the American team recorded 39 ft. 3 ins. (Barnes, 13 ft. 9 ins.; McGinnes 13 ft.; and Droegmuller, 12 ft. 6 ins.), and the

British Empire team, 36 ft. 0 ins. (Pickard, 13 ft. 6 ins. ; Bond, 11 ft. 6 ins. ; and Housden 11 ft.).

E. F. Housden, S.L.H., deserves a word to himself, for he has ploughed a lone, stiff furrow, with no coaching and hardly any encouragement of competition to help him towards the fine form he has achieved, while Bond has worked equally hard.

Mention has been made of Sabin Carr's schoolboy performance of 12 ft. 7 ins., but the American schoolboy's record belongs to Harry Smith, of San Diego High School, California. He in 1923 cleared 12 ft. 11 $\frac{1}{2}$ ins., but as he was nineteen years of age at that time he would be somewhat older than the average schoolboy on this side of the Atlantic. Sweden has for many years fostered pole vaulting as a fine body-building exercise for growing boys. In 1920 L. E. Tiren put up a record of 12 ft. 3 $\frac{3}{4}$ ins. at eighteen years of age, and in 1927 V. Eriksson, took the "under sixteen-year-old" record up to 10 ft. 2 ins.

Records of this sort by such young athletes might terrify us if we had only the past performances of our grown athletes to go upon. Luckily, however, in 1925 the London Athletic Club, which has really been the foundation stone of English athletics, elected to include a pole vault in the Public Schools Championship programme. O. G. Crossman, Bedford School, took the first title at 9 ft. 1 $\frac{1}{2}$ ins., but in 1928 H. G. Young, Bedford Modern School, barely sixteen years of age, increased the record to 10 ft. 1 in., and won the Midland Counties and Bedford Junior Championships, besides being second in the County Senior Championship, returning 10 ft. 2 $\frac{1}{2}$ ins. as his best effort. In the same year P. B. B. Ogilvie cleared 11 ft. 3 ins. before he left Charterhouse to go up to Cambridge, and I think there are even better things in store.

As an example of what can be done with careful coaching and encouragement, I may cite the case of my own three youngsters, all of whom have been pole vaulting for the fun of the thing and just when they have felt inclined so to do, since about the age of four years. Dick, at ten years of age, vaulted 6 ft. 2 ins., at eleven he set the Bedford Preparatory School

record at 7 ft. 0½ in., and at thirteen won the Bedfordshire Colts under fourteen years old Championship at 8 ft. 2 ins., and a year later cleared 8 ft. 10 ins. Joan at eleven years cleared 7 ft. 2¾ ins., and Peggy at nine was doing 6 ft. 8 ins. Girls should not go on vaulting much beyond the age of twelve, but boys who are well grounded in the rudiments of the art from the time they can toddle should do something big later on, provided the fond parent neither asks nor expects too much of them and thus sickens them of the sport all too soon.

The fact that pole vaulting is slowly but surely coming back into the schools is undoubtedly the best assurance for Great Britain's athletic future, and that we need some such guarantee is clearly revealed by world's statistics, based on performances at past national championships and subsequent records for the particular country. To take just a few cases for the sake of comparison. In sixty-two years British pole vaulters have produced an improvement of 10½ ins., Norway in twenty-nine years improved 4 ft. 4½ ins., and America 4 ft. 5 ins. in exactly half a century, while Japan has in eight years produced one man capable of touching 13 ft. and three or four to beat 12 ft. At the Olympic Games there has been an improvement of 2 ft. 11¾ ins. in thirty-two years.

The process of evolution has been steadily pressed forward, there have been marked improvements in pole vault form, and yet the present amazing records are not entirely due to the man and his methods. Impedimenta too has played an important part. Styles have been standardized, and skill has increased, but neither would have sufficed without smooth cinder surfaces, supple bamboo vaulting poles, and the slideway which is the latest adjunct to accurate endeavour.

At the time the change was made from poles of spruce, hickory or ash, to lighter ones of female bamboo, it was believed that the greatest possible vaulting height had been achieved. Tall, heavy men who could run fast were strong enough to support the weight of a solid pole, but they found their limit at just over 12 ft. because the cross strain on the wood at greater heights was too great for the heavy man to compete in

safety. The lighter men could swing on a pole to almost any height without danger, but the leverage of a 16 ft. solid pole carried with the hands perhaps 12 ft. from the thick end was so great that all running speed was lost. Bamboo poles, on the other hand, are mere feather-weights and they have moreover a great amount of elasticity. The added running speed, made possible by the lightness of the pole and the spring that comes from the "whip" when it reaches the vertical position, added from six to nine inches to the height a human being could clear. The introduction of smooth, firm cinder paths also accelerated the approach speed and then came the slideway, or vaulting-box, made of two-inch planking and sunk flush with the ground

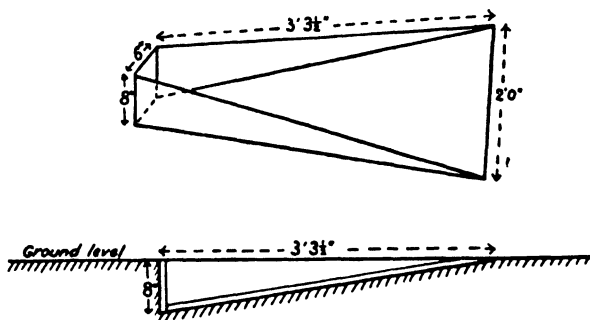

FIG. 22.

for the reception of the plugged end of the pole. The construction of the box is shown in Fig. 22.

With the coming of bamboo poles the spiked tripod termination was replaced by a plugged end. This was stabbed into a hole, 1 ft. in diameter, dug exactly in front of the jump. This made little difference, since the use of a spiked pole or a small hole necessitated an over-arm swing and jab down to get the point of the pole firmly planted for the vault. The slideway is open 2 ft. at ground level, towards the vaulter, inclining towards the sand-pit to a depth of 8 inches and a width of 6 inches. This allows the vaulter to throw the point of the pole forward with an under-arm action, so that he can bring his hands up in front of his face in a natural swinging movement, and he is

able therefore to get a running-action jump. In fact he runs off his take-off mark and the running action continues as his legs swing up towards the bar.

There is another point. With the old spiked poles, once the three prongs were imbedded in the ground the end could not be twisted, so that the vaulter had to go round a fixed pole. Nowadays the plugged end turns smoothly in the slideway and the pole, when upright, rotates as the vaulter effects his clearance of the bar.

The next consideration is that of speed, for a reason which will be proved mathematically in a moment.

A suggested style of run-up for a right-footed jumper is given in Fig. 23. For the details of how a run-up may be formed the reader is referred to Chapter XVI (The Long Jump). The difference to be found in the measurements set down is due to

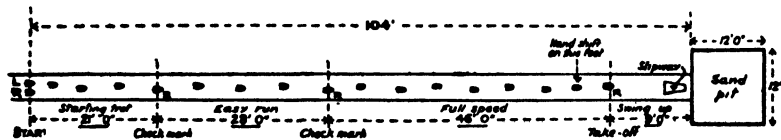
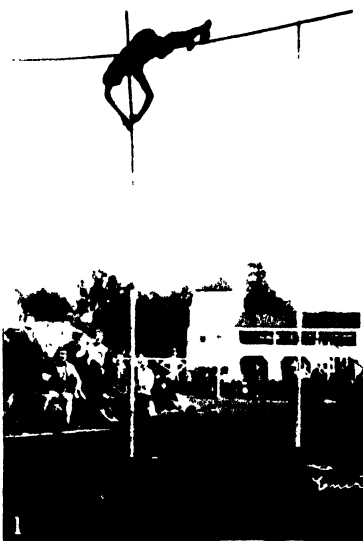

FIG. 23.

the allowance for pole carriage, which alters the stride action and length.

If the athlete is accustomed to jumping from the right foot, then the left hand will have the higher hold upon the pole, which will be carried at the left side, as shown in Fig. 24, on page 239. It will be seen that the right forearm is held across the body and parallel to the ground. The traction is straight forward, there is a good body lean, excellent push-off from the grounded foot, and a good pick-up of the right knee. During the run the left shoulder should be given a forward rotary movement; this combined with a half turn of the left wrist forward and backward partly compensates for the loss of left arm swing consequent upon the carriage of the pole. It serves also to keep the point of the pole directed straight ahead.



Pl. 33.

THE POLE VAULT.

Sport and General [Q 238

1 C. Hoff, Norway, clearing 13 ft. 11 $\frac{1}{4}$ in.; vertical lift just beginning. 2. Hoff shows finish of vertical lift. 3. Hoff demonstrates pole release with flat lay-out. 4. Lee Barnes, U S A, vaulting 13 ft. Note slide-way, whip of pole, balanced release and left-hand withdrawal at a finish of vertical lift



1. The shift.



2. The hang.



PL. 34]

3. Vertical lift.



*C. I. Topdell and
C. L. Chapman.* [Q 239
4. The kick release.

THE POLE VAULT.

F. R. WEBSTER, WEDS COLTS (UNDER 14), RECORD HOLDER, 1929, 8 FT. 10 IN.

The reader will see from Fig. 23 that the hand-shift is made as the left foot completes its last stride before the right foot takes off, *i.e.*, makes its spring. In point of fact three things happen as the left leg completes its last stride. Still assuming the man is going to jump from the right foot, then, as the left leg makes its last stride, the pole point is pushed forward into the slideway with an under-arm swing, the left hand is pushed forward and up, and as the shaft rises the right hand slides up it until it touches the left hand which has the higher hold. The pushing forward and up of pole shaft and left hand, the sliding up, or "shift" of the right hand up the pole shaft, and the pushing forward of the pole point into the slideway at completion of the final left leg stride are all seen in the picture, No. 1, Plate 34. It will be noted that the right leg is coming through for the take-off, while the young athlete has contrived a good "crouch" preparatory to the spring.

As the pole point strikes the end of the slideway the right heel is placed hard down on the take-off mark and the left foot swings forward Fig. 25, p. 241. The two impacts—pole point with end of slideway, and foot with ground—must be simultaneous and forcible. Note that the take-off spot is about a foot in rear of an imaginary plumb-line dropped from the hand-hold and that the arms are at full stretch above the head. From the right heel the body rises right up on to the toes, and the right leg is fully straightened in a powerful upward drive. The left arm and right forearm are now parallel to the pole which is close to the vaulter's left shoulder and cheek. The left knee at once picks up, but the right leg is allowed to hang until both legs are raised towards the bar with a strong hip bend. The first action off the ground, of a right foot vaulter, is well shown in the picture, No. 2, Plate 34.

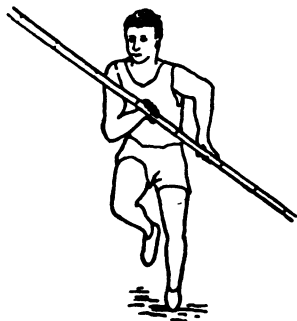

FIG. 24.

Before going any further with the description of the vaulting action we will pause for one moment to consider the question of speed and power, as promised above. In this matter the diagram in Fig. 25, page 241, should help us a lot, while the calculations will no doubt interest those of my readers who have looked into the scientific side of athletics.

To determine the effect of approach speed upon the height the athlete is able to, or should, clear, it is necessary to find the height to which a body will rise against gravity, when its horizontal velocity is converted into vertical velocity. Let us assume that a pole vaulter approaches his take-off at a rate of 25 ft. per second, *i.e.*, 100 yards in 12 secs. The symbols in our calculation shall be v = velocity, h = height obtained, g = acceleration due to gravity, and t = the time taken for a body with velocity v to reach a given height.

Then

$$(i) \quad v = gt; \text{ or } t = \frac{v}{g} \text{ secs.}$$

$$(ii) \quad \text{Now } h = \frac{1}{2}gt^2$$

$$\therefore h = \frac{1}{2} \times 32 \times \left(\frac{25}{32}\right)^2 = \frac{25^2}{4} \text{ feet.}$$

$$= 9.76 \text{ ft. or } 9 \text{ ft. } 9 \text{ ins.}$$

But this height obtained applies to the centre of gravity of the body in question. Assuming the centre of gravity of a man when running is at the mid-point of a line drawn between the upper ends of his femur it would be approximately 3 ft. from the ground and the line of his take-off, and should be raised by merit of his speed of 25 ft. per second to a height of 9 ft. 9 ins. + 3 ft. = 12 ft. 9 ins. If, however, the vaulter is capable of running 100 yards in 11 secs., *i.e.*, his approach run is made at a speed of 27.3 ft. per second, then the height h is found to be 11.7 ft., so that he should be able to raise his centre of gravity to, and clear a crossbar at, 14 ft. 7 ins.

These figures relate purely and simply to the merit of the speed of run-up, and such factors as friction of the pole point and air resistance have not been allowed for, and the latter is a very large factor indeed, which must have an adverse effect upon the height obtained. On the other hand, no favourable

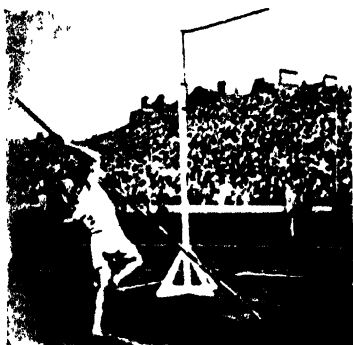

1. The take-off.

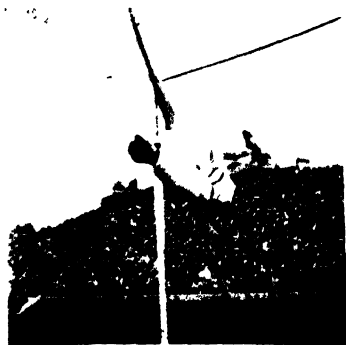

2. The pendulum swing.

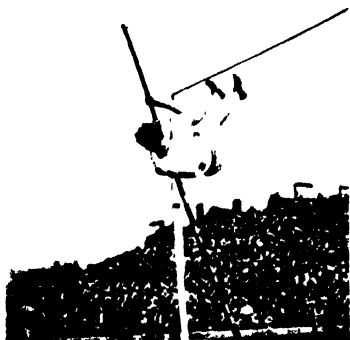

3. The arm pull

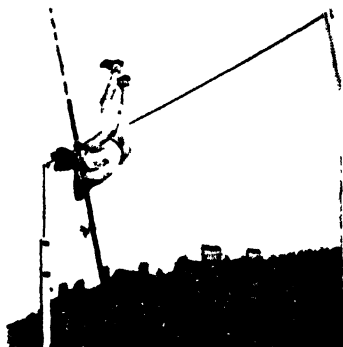

4. The leg shoot.

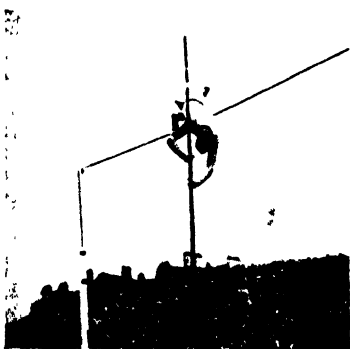

Pl. 35]

5. The turn.

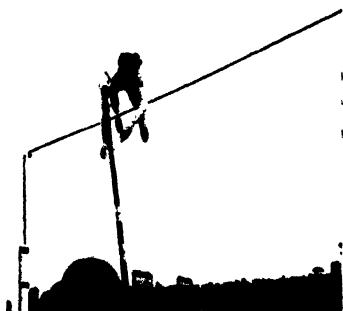

6. The vertical lift. [Q 240

THE POLE VAULT.

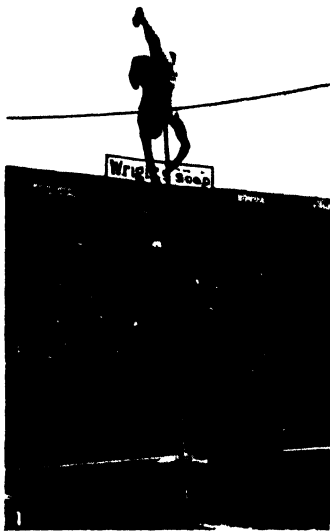

PL. 36]

THE POLE VAULT.

Sport and General [R 241

1. C. Harlemann, Sweden, showing single kick in half jack-knife form. 2. E. Rydberg, Sweden, completing turning movement in single action style. 3. Sabin Carr, U.S.A., half-way through push-up, double action style. 4. Carr effecting left arm clearance, double action, partial jack-knife finish.

The Pole Vault

allowance has been made for the vertical lift whereby the athlete raises his body a considerable way above the height of his hand-hold upon the pole when it has reached its vertical position, and since Gold, when he set the American Western Conference record at 12 ft. 10 ins., had his upper hand hold at 11 ft. 2 ins., the vertical lift, properly performed, must add at least eighteen inches to the height the athlete is able to clear.

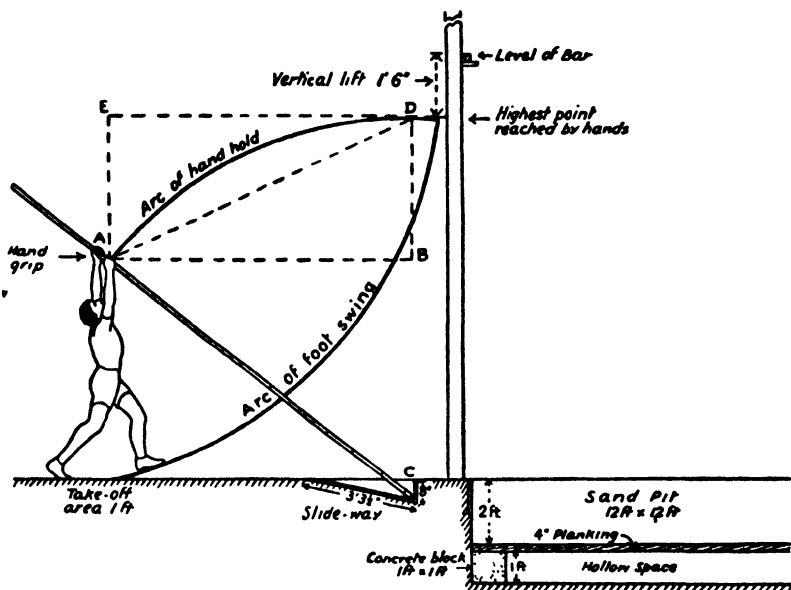

FIG. 25.

The whole case is, of course, open to considerable argument, but one thing the figures do bring out is the enormous advantage of speed in the run-up, since the height attained in swing up is proportional to the *square* of the velocity when running, so that an increase of speed equivalent to even one-fifth of a second less in 100 yards provides an addition of over 4 ins. to the height reached in the swing up.

In Fig. 25 the athlete, who, we will assume, weighs approximately 150 lb., is seen taking off. The pole point has reached

Athletics of To-day

the end of the slideway C, and he is in process of converting his forward velocity, due to the approach run, into an upward force by means of his spring. There are then two forces at work simultaneously—one along the line AB, which represents an energy of 937 foot-lb. due to his weight and the velocity of his approach run, and another along the line AE, which is equal to 600 foot-lb. due to the energy of his spring upwards. If the two lines referred to are formed into the parallelogram ABDE we get a resultant along the line AD showing a kinetic energy of 1,120 foot-lb. and its direction, which is the force existent at the instant of take-off, along the arc AD. For the sake of convenience I have added to this diagram a section showing the proper method of constructing the sand-pit for the vaulters to land in and have given the usual dimensions.

For the benefit of the novice and the young pole vaulter who has followed me through the stages of the approach run and take-off, I will now describe the full action vault as shown in Plate 35. In these six pictures, each of the athletes has made his spring from the *left* foot.

In No. 1, Lee Barnes, U.S.A. (Olympic Champion, 1924) is just completing his take-off. Notice that the body is already going well to the pole through the bending of the arms at the elbows, and that the right knee is beginning to pick up to get height into the leg swing.

No. 2, of V. Pickard, the Canadian record holder, shows that the bending of the arms at the instant of take-off is only a temporary measure to bring the body close in to the pole. Note this point, for many a man spoils good vaulting by letting his body fly out from the pole. At this stage of the vault the head is still well back and the body is hanging loosely from the hands as the legs go up in a strong pendulum swing. This swing is gaining speed by the strong bending of the body at the hips. Observe the slight knee flexion and that the legs are beginning to turn over on to their left sides.

In No. 3, Lee Barnes shows how the body takes up the turning movement to the left, which the legs have started, and the point at which the arms begin to raise the body by means of

a strong, steady pull, as the feet are approaching the level of the bar.

The next picture, No. 4, is of W. Droegmuller, U.S.A. He has now got the chest almost square to the pole, which is still close to his body. When this chest-to-the-pole position is reached, the arms complete their pull-up with all possible speed and snap. This action shoots the feet and hips well above the bar as the pole reaches the vertical position, but the body still continues to turn towards the pole; in the case of a left-footed jumper the turn is to the left.

In No. 5, C. McGinnes, U.S.A., shows the beginning of the push-up position, but his hands should be closer together. As the feet reach their highest elevation the turning movement of the body is completed by a kick back and up with the take-off leg and a kick down with the other leg.

This action is even better illustrated in the picture of C. Harlemann, Sweden, in No. 1, Plate 36. Note in the pictures of both McGinnes and Harlemann that although the legs have begun to descend on the far side of the bar the arms have not yet contributed their part of the vertical lift, or push up, which raises the upper part of the body over the bar.

This full arm lift is well shown by Lee Barnes in No. 4, Plate 33; the even balance of the leg chop down, which accompanies the lift from the arms, is seen in No. 6, Plate 35.

Pictures Nos. 1, 2 and 3, Plate 33, show Charles Hoff, the Norwegian, in three stages of his clearance action, and each was taken on an occasion when he broke a world's record.

The style described is really a single action vault in which the vertical lift is made possible by the speed of the approach and the strength of the swing up. It has the great advantage that small boys can begin it as is seen in No. 3, Plate 34, in which a boy of ten is seen lifting himself over the bar at 7 ft. 0½ in.

The double action style, as used by the world's record holder, Sabin W. Carr, U.S.A., 14 ft., is much more complicated, but is undoubtedly the very last word that has yet been said in vaulting form. In Carr's style the feet and legs are thrown

straight ahead at the take-off, so that they pass well *under* and *beyond* the crossbar which ultimately they will go over. It follows therefore that this action can only be used at great heights, when time is allowed for the feet to come in from their forward swing and back to the pole side of the bar ; otherwise the standards must be moved further away from the take-off mark and slideway. At great heights it will be found that the feet reach their highest point well above the level of the bar, before the pole is perpendicular. When the leg swing is finished and the feet are as high as it is possible to fling them, the hands and the pole are pulled in to the shoulder, or face, according to the athlete's body rise.

This concludes the upward and forward swing effort ; both legs are now fully extended, but separated in a V shape. If the man has taken off from his left foot, then the left leg will be thrown straight out, and the right leg, rather higher than the left, will be bent at the knee, because a turning movement already has commenced. This leg shoot will have raised the feet a little higher, and the left leg is next kicked hard back to the right, while the right leg kicks forward and to the left. This double kick action brings the vaulter round so that he is in a face downwards position and looking right down on to the slideway (see picture No. 2, Plate 36, of Rydberg, the Swedish vaulter, who is just completing the turning movement but has allowed the pole to get away from his neck). The completion of the leg action is most beautifully shown in No. 3, Plate 36. No one but a great gymnast could maintain such perfect balance and body control as is here displayed. Note the way in which the body is partly arched, that the hands and head are still below the bar. The left hand, its work done, has released its hold in the next picture (No. 4, Plate 36), the left arm is being lifted over the bar, and the right arm is completing the push up ; remember that the right hand has had the upper hold the whole time. From this position the legs would be snapped down in the "jack-knife" finish, or the movement can be completed with a secondary double kick and accompanying arm action, as shown by F. H. Sturdy

(No. 1, Plate 37), Sabin Carr's "stable companion" at Yale, who can almost always beat 13 ft. in competition.

The height of the hand-hold on the pole varies with the height of the individual, but once you have settled your grip it is well to vary it as little as possible. Up to $11\frac{1}{2}$ ft. the height can be obtained by standing the pole upright in the slideway and taking the grip for the upper hand at the point where bar and pole intersect, but an $11\frac{1}{2}$ ft. hand-hold should get a man over between 12 and 13 ft. If he is going to vault higher than that he must learn to carry the pole with a 12 ft. or 12 ft. 6 ins. upper grip. The great heights come from physical cleverness in the air rather than from an exaggeratedly high grip upon the pole. Even as a novice you should try to perfect a form that will allow you to clear your best heights with a grip that is lower than the height of the bar.

The hand-hold, however, must not be considered by itself, for it is largely affected by the position of the starting line which, in its turn, gives the position of the take-off. It may be that a man has a fixed mark, starting from which he can clear all vaults up to a certain height. The bar goes beyond that height, and he needs to take off a foot further back from the slideway, so he raises his grip on the pole by a foot, but must also move back his starting mark a foot, or his run up will fall wrong.

During the approach run some means must be found of counter-balancing the handicap of having to carry the pole. It may be remembered that the hurdler was faced with a similar problem through the interposition of 10 hurdles in his race, but solved the difficulty of interrupted running action by means of special hip flexibility. In the first place running speed is largely dependent upon body angle (see Chapter II). If the athlete runs with the pole point pitched up, his body carriage will be too erect. If the pole point is directed to either side his striding will be uneven and his pace slow, added to which the carriage of the pole in any other position than straight ahead and parallel to the ground, or pitched downwards, will necessitate an extra sideways or over-arm action when the

point is thrown forward into the slideway. The upper hand has a palm upwards grip and the lower hand a palm downwards grip ; in both cases the thumbs are the nearest part of the hands to the top end of the pole. The hands are held about 36 ins. apart.

If, in running, the point of the pole is raised above a " parallel to the ground " position, the upper part of the body remains set and all the work of traction falls upon the legs. If the point of the pole is kept down it will be found possible to swing the pole directly backwards and forwards as one runs. Charles Hoff did this to perfection. This allows for a compensatory shoulder swing and lengthens out the stride from 18 to 24 ins. And, moreover, the whole body being held loosely with a relaxed hand grip and the pole " on the directly forward and backward swing," the pole point goes into the slideway with considerably more force, and a more vigorous take-off is obtained, than would be possible from a rigid, unswinging pole carriage. The grip of the hands must, of course, be consolidated as the point of the pole goes into the slideway.

The vaulter should learn to harmonize the speed of approach and vigour of take-off with the height being attempted. For example, if one can clear 12 ft. it is obviously not necessary to put all one's speed and take-off vigour into the effort to effect a 10 ft. clearance. A well taught and well trained vaulter who is sure of his ability to clear 12 ft. to 12 ft. 6 ins., should be able to get over 10 ft. to 10 ft. 6 ins. with a light run of three to six strides, relying upon his swing, pull-up, and vertical lift to push up or carry him over the lower height.

Try to ensure that you are at maximum running speed when you reach the take-off. Long-striding vaulters usually need a long run ; short, quick-striding men usually reach their maximum speed in a shorter distance. The approach run should have a cumulative effect, if maximum heights are to be reached. The plan is to have the speed steadily increasing from starting mark to take-off point. Learn all about your own run-up by sweeping the run-way before each attempt. Then, after you have vaulted, go back and study your foot-work.

Many vaulters show a tendency to hit the pole with the inside (take-off) leg as they rise into the air. This fault is due to incorrect foot placement at the take-off. When the foot is stamped down for the spring to be made, it should be directly in line with the pole point in the slideway (see Figs. 23 and 25). Assuming the man springs from his right foot, any deviation from the right foot placement immediately in line back from the pole point should be to the left, so that his body will swing to the right across the pole. If he puts his right foot down to the right of the line back from the pole point, the subsequent swing up will carry him in towards the pole, which he will hit with his left thigh or knee.

It has been mentioned that the hands grip the pole 36 inches apart during the approach run. But one cannot vault with this grip; otherwise the lower hand will serve merely as a prop and will not contribute to the pull up. The lower hand is brought up the pole until it touches the upper hand in a shift action. In the old time over-hand shift the higher hand used to be brought directly up and over in a semi-circular swing to a full arm extension, but it usually led to a lack of balance in the vault. The under-hand shift is far better. The shift is made on the last stride of the leg from which the spring is *not* made, *i.e.*, right foot take-off, make the shift on the last stride of the left leg. The rear hand comes directly through to the front, and actually just touches the body, and the pole is pushed up to a full extension of the rear arm as the lower hand slips up the pole shaft to a grip just below that of the upper hand. The lower hand consolidates its grip just as the pole point strikes the end of the slideway, and the "hands-touching" position must be maintained until the pole is ultimately pushed away in the final clearance action.

The question of position at take-off is of major importance. First the arms. The flexing of the arms, so that the elbows are in a line with the shoulders, gives the cramped position of the novice who is afraid to let himself go. A partial flex, with the elbows level with the uptilted chin, almost certainly ensures good balance in the vault, but does not allow maximum vigour,

and the full arm extension shown in Fig. 25 is strongly recommended, if the athlete has patience to practise it long enough to build up a perfectly balanced swing to follow.

Placement of the take-off foot in relation to arm extension and hand-hold is all a question of triangulation. An imaginary plumb-line dropped from the hands at full arm extension to the ground gives a right-angle triangle, enclosed by the pole, ground, and an imaginary plumb-line. Any take-off spot which brings the jumping foot to a point on the slideway side of the imaginary perpendicular is wrong, because the pole will beat the body swing as both rise towards the bar; also, with the foot placed down ahead of the hand-hold it is impossible to get the spring from the toes. G. P. Faust, the Oxford and Cambridge record holder, and a host of other first-rate vaulters, say that the arms should be fully extended upwards and the take-off foot be placed directly under the hands for the spring. According to the mechanics of pole vaulting they are right, since their take-off causes the feet to follow the arc of a circle which has the ground for a tangent. Another school contends that the take-off spot should be a foot or so back (away from the slideway) from the imaginary plumb-line dropped from the hand-hold. Their opponents argue that this take-off must be wrong, since it tends to drive the edge of the swing-circle into the ground. The answer to this is that a slight crouch converts the arc; and, in any case, the "hang" gained by a back-of-the-plumb-line take-off position compensates fully for any loss of traction.

During the early stages of the swing the body hangs loose from the hand-grip, but the powerful upwards swing must be aided by a strong bending of the hips and a slight bending of the knees.

One so often sees the novice quit the pole before it reaches the perpendicular. This means that his push-up merely pushes the pole down and away, and he has no vertical support to push up from. The real cause of this trouble is that the vaulter himself has lacked leg swing and so has failed to help the pole to rise through the full range of its arc. Then again when the vaulter crashes down on to the bar, instead of

clearing it, the trouble is generally due to his having released the pole too soon, because his leg swing has not been strong enough to carry his body to the proper height.

The leg action during the upward swing comprises three successive inverted Vs, or triangles. The first V is formed when the take-off foot is on the ground and the free leg swinging forward; before the free leg kick has spent its force, the take-off leg starts a kick of its own and passes the free leg, thus forming the second V. This helps the double-action vaulter to hold a "body-facing-the-bar" position as he rises. The free leg now gives its third kick and again passes the take-off leg, thus forming the third V. This applies to the double-action vaulter, who is assumed to have taken off from the left foot. The "scissors" action follows and can be made either a separate unit or combined with the third swing kick. If the "scissors" action is managed, the take-off (left) leg will go upwards and to the right and the right leg will follow also upwards and to the right. The right leg makes the follow up kick, as it must be the higher of the two, or the body turn cannot be completed. The final "scissors" kick V-leg finish is well shown in Picture No. 3, Plate 37, of C. Harlemann, but the "jack-knife," in which the whole body forms an inverted V over the bar, offers an alternative. In Picture Nos. 3 and 4, Plate 36, Sabin W. Carr is using a half jack-knife finish, but perhaps the jack-knife action may be explained best by Fig. 26, on page 250.

When the vaulter has got his legs across the bar, position AB, the arms are still flexed at the elbows and the hand-hold is firm on the pole. A distinct pause in action follows as the legs are dropped from B to C, when the body holds the inverted V position AC. over the bar. In the next movement the vaulter pushes himself up to a full-arm extension which gives him the position DE, shown in the second of the sketches. He then clears his chest from the bar by raising his body and flinging back his arms and gains the position FE. The movement that follows is well shown in Picture No. 1, Plate 37, of F. H. Sturdy, one of the Yale pole vaulters.

In order that the jack-knife, which is really a mid-air half-arm push-up, combined with long-arm balance, may be performed effectually, it is necessary that the vaulter be practised in the art of standing on his hands and of holding that position before snapping the feet back to the ground.

Since the pole vault is, of necessity, a built-up event, it follows that certain parts of the structure can be produced, or

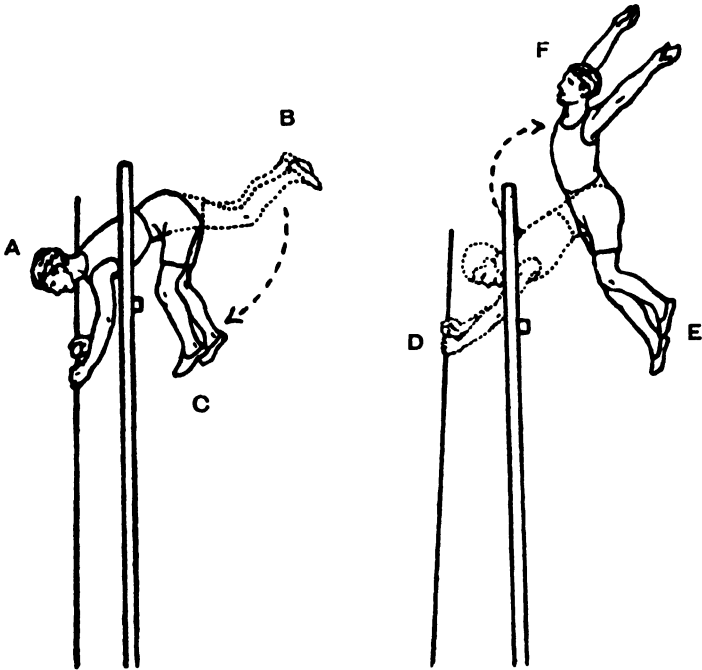

FIG. 26.

improved, separately. Foot-elevation is so important that the aspirant to pole vault honours should practise often without a bar in place and strive at each vault to see just how high he really can fling his feet above his head. The strength, but not the quickness, needed can be produced by circling and other exercises on the horizontal bar, and a fast leg swing may be developed on the parallel bars.

For the "scissors" kick and push-up there is an excellent combined exercise, but the kick phase must be developed first. The athlete lies down on a thick gym. mat, or at the edge of the sand-pit, on his back. The feet are then thrown up until the weight is resting on the shoulders. The usual take-off leg is then kicked back and the other leg forward. If this movement is performed with plenty of leg "punch" the man will pivot right round and fall face downwards. As soon as this gymnastic trick is mastered he should try to finish off the body reverse with a push-up from a half-arm, palms down, position. Do not try this trick on a hard floor.

A vigorous pull-up, combined with a perfect take-off, will look after about 75 per cent. of the vault. Pull-up power may be built up in the initial stages of training by pull-up exercises to raise the chin to the level of the hands on the horizontal bar or a rope, but very soon the athlete should take to his pole. He should stand it upright in the slideway, and take a handhold that will allow him to have both arms at full stretch above his head. He then pulls himself up until his chest comes to his hands. He makes no spring, but swings his legs upwards and outwards as he pulls, the pull raises his body, and the swing carries it round the pole, which he pushes away and himself lands in the sand-pit. This is really a standing vault. Besides adding to the pull-up power it affords fine exercise for developing pole balance. It is not, however, easy to perform as well as is shown in No. 2, Plate 37.

To develop pulling power, leg swing, and foot elevation simultaneously, do quite a lot of vaulting with an approach of only three walking steps. The pushing of the pole point into the slideway and the shift of the lower hand should be practised in progressive stages—first at a standstill, next at a slow walk, then at a trot, a slow run, a half-speed run, a three-quarter-speed run, and, finally, with the full run at top speed. In these exercises one should take heed as to where the take-off foot lands.

In practising the take-off pay special attention, as you rise, to the "hanging" of the body in the flexor muscles.

Quite 95% of actual vaulting practice should be done for style at such heights as one can be certain of clearing. On the other hand, it is necessary to get accustomed to tackling extreme heights, so full trial jumping may be undertaken once a week, preferably on Saturdays.

TRAINING ✓

Train with the sprinters for approach speed, with the long jumpers for even striding and take-off, build up the muscles of the back, shoulders, sides and abdomen in the gymnasium at first, and, for the sake of keeping these muscles fit, do plenty of javelin and discus throwing, and, if the implements are not too heavy for you, tackle the shot put and hammer as well. High and low hurdling, and high and long jumping are also good for the legs, while the hop, step, and jump will help you to develop leg swing with accurate timing. High Jumping should be done in the "Eastern Cut-off" style (see Chapter XV).

When you have reached competition form it will be enough training for you to practise sprinting with the pole and a few easy vaults for style on Monday. Trot a half speed 300 yards and practise half a dozen sprints with the pole, without any vaulting, on Tuesday. On Wednesday vault at nearly your top height without being bothered with any anxiety about whether you clear it or not. Your object should be form and the correction of any known faults in your style. Just a light run to keep everything loose is enough for Thursday. Friday is a rest day, and Saturday you should try for a competition. Failing that, frame up a serious vaulting trial, and, whether any one is working with you or not, allow the same amount of time to pass between attempts as you would expect to elapse in competition.

Body building, stretching, balancing, and suppling exercises should form part of the training programme right through the year. Learn tumbling and acrobatic tricks.

CHAPTER XIX

THROWING THE JAVELIN

THE javelin is among the most ancient of weapons. Saul threw one at David and thereby gave W. E. B. Henderson, the famous Oxford Blue, the inspiration for a subtle joke a few thousand years later. As a warlike sport javelin throwing has, I suppose, been practised since first a camp was pitched. It was a "peaceful" pastime at the Tailtin Games of Ireland, 1829 B.C., and was practised at the ancient Olympiads and the old Scandinavian Northern Games of the Vikings. It was Per Henrik Ling, I fancy, who revived the sport in Scandinavia, at the same time that he gave the world his Swedish system of gymnastics. Anyway, the event was included in the first Swedish Championships held at Halsingborg in 1896, Harald Andersson winning at 202 ft., with his right and left hand throws added together. It was at the request of Sweden that the event was included in the programme of the intercalated series of Games at Athens in 1906. The best hand throw only was reckoned. Two years before Andersson (Sweden) had thrown just about 120 ft., but at Athens his countrymen cleaned up nicely. The winner, Eric Lemming (No. 1, Plate 38), a Stockholm policeman, standing 6 ft. 3 ins. and weighing 14 stone, was then twenty-six years of age and had been competing since he was sixteen. He threw 176 ft. 10 ins. and three other Swedes beat 145 ft., so that no other country had a look in. Great Britain and America were not represented, although Germany, Finland, Hungary, Greece, and Bohemia all entered men.

When the Olympic Games came to London in 1908 we entered men for everything—except the pole vault—irrespective of whether they made any sort of showing in the English

Olympic Trials, held in May, or not. There were to be two javelin throwing contests at that Olympiad—the orthodox “Held in the Middle” style and “Free Style.” At the English Trials, A. H. Fyffe, O.U.A.C., won the orthodox event at 108 ft. 9 ins., while the late H. A. Leeke, C.U.A.C., reached 135 ft. 3½ ins. in the free style—and very free it was in those days. In one contest a wild Irishman broke the only javelin provided with his first throw and won the prize, because none of the other competitors got a chance of throwing at all. At the Swedish trials, Lemming put up a new world’s record of 188 ft.

The absurdity of including a free as well as a confined style was shown at the Games themselves when Eric Lemming took both contests, doing 178 ft. 7½ ins. in the free style, and 179 ft. 10½ ins. in the restricted style.

Two years later we started the English Amateur Field Events Association, and in 1911 the first English Championship was held. I have cause to remember the occasion since the Honorary Secretary of the City Police A.C., who were staging the championship in connection with their annual meeting at the Crystal Palace, rang me up the day the entries closed and stated that he had only three entries and asked if I could help him out. I said, “Yes, I’ll enter, but I don’t know anything about it.” In point of fact I had never thrown a javelin before, so perhaps I was lucky to beat a moderate field and win my first English championship with a throw of 118 ft. 4 ins.

In some newspapers it has been remarked recently that Englishmen have no aptitude for javelin throwing and that there has been no improvement in the sport since it was first introduced into England, and yet I won the Championship of 1911 at 118 ft. 4 ins. and in 1928 threw 158 ft. at the Royal Airship Works Sports, Cardington—good enough for third place at the 1908 Olympiad, but only good enough to give me fourth place at a small country meeting in 1928. So we must have made some progress in the last twenty years, despite the Jeremiahs who think that English field events men never can be any good.

The years of evolution up to the outbreak of War were full of amusing incidents. On one occasion the late A. E. Flaxman and I were walking through Leeds on our way to a sports meeting at Roundhay, each carrying a javelin, when we heard our purpose, thus armed, discussed by two street arabs, who decided we were going "eel-sticking." With us the "free style" obtained for some further years and nearly led to more than one case of manslaughter. I think it was an Irishman named Cremin, or it may have been Eustace, who hit upon the notion of grasping the $8\frac{1}{2}$ ft. spear by the extreme tip of the tail, whirling it around his head, and letting it fly. One afternoon he performed his famous "wheel feat" at the Crystal Palace and landed the steel-headed weapon clean through the big drum, whereupon the indignant drummer instantly broke the offending missile, and I heard W. E. B. Henderson remark, "Extraordinary thing—the antipathy all these javelin throwers seem to have to music."

In 1913 we all got down to the orthodox "Held in the Middle" style and the late F. O. Kitching (No. 2, Plate 38) put the British national record up to 143 ft. 3 ins., while Oswald Pirow, South Africa, won the last English Championship held under the auspices of the A.F.E.A. at 142 ft. $3\frac{1}{2}$ ins. The next year, the A.A.A. took over the event, and N. Koczan came over from Hungary and won it at 195 ft. 11 ins., and I think that Kornerup Bang, a magnificent Dane, who fell fighting for England in France, was second.

America, meanwhile, had taken up the event. The late Ralph Rose, who held the world's shot putting record for many years, took the first A.A.U. Javelin Throwing title, 1909, at 141 ft. 7 ins., and by 1916, G. A. Bronder, Jr., Irish-American A.C., had improved the American record to 190 ft. 6 ins.

Neither Great Britain nor America was represented by javelin throwers at the fifth Olympiad at Stockholm in 1912, when two types of contest were again included, because the Swedes are very keen on developing both sides of the body equally. Throwing in both events, however, was in the orthodox style. Eric Lemming took the best hand throw at

Athletics of To-day

198 ft. 11 $\frac{3}{8}$ ins. from J. J. Saaristo, Finland (No. 7, Plate 40), 192 ft. 5 $\frac{9}{10}$ ins. The other contest was decided on the best aggregate total—that is to say, each competitor threw first with his right and then with his left hand, and the best throws with each hand were added together.

The results set out below will be illuminating to any one who has tried to throw with the hand he is not accustomed to use :

	Right Hand		Left Hand.		Both Hands.	
	ft.	ins.	ft.	ins.	ft.	ins.
J. J. Saaristo, Finland	200	1·57	158	10·29	358	11·86
W. Siikaniemi, Finland	177	5·5	154	3 $\frac{1}{2}$ $\frac{9}{10}$	331	9 $\frac{9}{10}$
V. Peltonen, Finland	175	9·84	153	1	328	10·34
E. Lemming, Sweden	191	4·45	132	1·03	323	5·48

That was the first time 200 ft. had ever been beaten, and I believe that both Saaristo's left hand throw and his aggregate total constituted world's records.

By this time the Scandinavians had built up a really first-class technique of their own, but they received no little assistance from that enterprising firm, Messrs. Sportsarticles, of Helsingfors, Finland. We, in England, had to use the most appallingly "whippy" ash-shafted weapons, but Mr. Arno Hohenthal, of Sportsarticles, envisaged the merits of Finnish birch. He knew that the further north the trees grow the harder the wood becomes. A transportable saw-mill was set up in the midst of the selected forest, and only the sun-side, outer layers of the birch trees were selected for javelin shafts. From this wood the vitamin was extracted by a special process to prevent warping, and consequently a shaft was obtained that stays so rigid in flight that a birch-shafted javelin of this type will fly 30 ft. to 35 ft. further than one that is shafted with ash. The one disadvantage about these beautiful implements is that they snap easily in the hands of the inexpert thrower, a circumstance that has prevented many clubs and schools from taking up the sport. Recently, how-

ever, the London firm of Lillywhite's have produced a bamboo-shafted practice spear and a laminated javelin for competition. Both are practically unbreakable, and the latter does not warp, and is just about the last word in javelin construction.

The production of the first wonderful Finnish spears no doubt had a beneficial effect upon the sport in Finland, for the Finns found themselves beating the world's best throwers, including the Swedes, and they really got down to their job, although Lemming, just after the Stockholm Olympiad, had raised the world's record again by throwing 204 ft. 5½ ins. At the Baltic Sports, held at Malmö, Sweden, in July, 1914, Jonni Myrra, eighth in the best hand throw at Stockholm, 168 ft. 4.86 ins., beat Lemming's performance with 207 ft. 7 ins., and at Stockholm in August, 1919, reached 216 ft. 9¾ ins.

In 1917 Sweden produced a really wonderful thrower in Y. Häckner, who made the present world's aggregate record of 374 ft. 11¾ ins. (right and left hand throws added together). He did not, however, stay long in competition, for a child ran on to the ground one day when he was throwing, and the spear went clean through it, after which Häckner never touched a javelin again, although the accident was due to no fault of his.

Then came the 1920 Olympiad at Antwerp. I spotted four very lusty Finns and a likely-looking young Esthonian—A. Klumberg—at the parade of nations, for I had heard already something of their prowess. The Swedes, "Gunnar" Lindström and E. Blomqvist, I had thrown with in Stockholm the year before, and there were one or two well thought of Americans, but no British entries. Placings worked out pretty well according to form, but Jonni Myrra (No. 3, Plate 38) introduced us to something new in the way of style, and the manner in which the first half-dozen men performed was nothing short of amazing, as will be realised from the following figures, when it is remembered that the Olympic record stood at 200 ft. 1¾ ins.:

Athletics of To-day

Antwerp Olympic Games Results, 1920

J. Myrra, Finland, 215 ft. 9 $\frac{3}{4}$ ins. (Stockholm, 1912, 8th, 168 ft. 4·8 ins.).

V. Peltonen, Finland, 208 ft. 4 ins. (Stockholm, 1912, 9th, 161 ft. 5 ins.).

P. Johansson, Finland, 207 ft. 0 ins.

J. Saaristo, Finland, 204 ft. 8 $\frac{5}{8}$ ins. (Stockholm, 1912, 200 ft. 1 $\frac{1}{8}$ ins.).

A. Klumberg, Esthonia, 204 ft. 8 $\frac{3}{8}$ ins.

G. Lindström, Sweden, 198 ft. 6 $\frac{5}{8}$ ins.

M. S. Angier, U.S.A., 191 ft. 11 $\frac{1}{8}$ ins.

E. Blomqvist, Sweden, 190 ft. 10 $\frac{5}{8}$ ins.

J. C. Lincoln, U.S.A., 189 ft. 10 ins.

Another thing that struck me at that Olympiad was that the Americans were evolving a style of their own, closely allied to the shot putting action in the final delivery of the missile, but totally different from the running throw as practised by the Scandinavian experts. It did not, and does not, appeal to me as being a good method, and it certainly is not so graceful as the other ; but, for all that, a number of Americans have succeeded in passing the 200 ft. mark.

The post-War period in England has been noteworthy. In 1920 I went a little better than the late F. O. Kitching's native record, but soon found my master through discovering J. Dalrymple, a diminutive Scot of colossal strength and tireless energy and patience. For a couple of years I kept the upper hand of him, but in 1924 he was right beyond my poor powers, for although he failed to do himself justice at the A.A.A. Championships he reached 186 ft. 5 $\frac{1}{2}$ ins. at the L.A.C. Summer Meeting a week later and with D. de Silhouette, of the Seychelles Islands, represented Great Britain at the Olympic Games in the following month. At Paris he strained his elbow in practice and so was out of that hunt.

Jonni Myrra retained his Olympic laurels with a throw of 206 ft. 6 $\frac{3}{8}$ ins., Gunnar Lindström was second at 199 ft. 10 $\frac{1}{8}$ ins., and E. G. Oberst, U.S.A., was third, 191 ft.

4 $\frac{5}{16}$ ins. Lindström was unlucky in not quite finding his form at the right time, for in the following month he raised the world's record to 218 ft. 6 $\frac{7}{8}$ ins. This record was destined to stand for some years.

The English native championships, unwisely abandoned after only a three years' trial, produced such men as Corporal Eyles, who deprived me of my title in 1924, while the Provincial Universities gave us two excellent throwers in P. Fisher and W. P. Abell, both of Nottingham University College. The latter made the official English national record of 166 ft. 1 $\frac{1}{4}$ ins. in 1927, but neither he nor Eyles was given a place in the British Olympic Team, 1928, although the latter had beaten 176 ft. Not present Olympic form perhaps, but it would pay to encourage such men by giving them the just reward of their labours. Consider, for example, the improvement in Myrra's form between 1912 (8th) and 1920 (1st).

Since Dalrymple became A.A.A. Champion in 1923 and E. G. Sutherland, South Africa, held the title in 1924, no Britisher had a look in at the Championships until Stanley Lay came over from New Zealand in 1928. In 1925, Bela Szepes, Hungary, won at 176 ft. 1 in., but was beaten in 1926 by O. Sunde, a magnificent looking Norwegian, who threw 201 ft. 3 ins. But in the next year the little Hungarian pulled out a new British record of 212 ft. 7 $\frac{1}{2}$ ins., beating Sunde, 203 ft. 9 $\frac{1}{2}$ ins., and Dalrymple, 183 ft. 7 ins., while G. C. Weightman-Smith, the South African and C.U.A.C. hurdler, amazed us all by placing fifth at 174 ft. 11 $\frac{1}{2}$ ins., without showing the faintest glimmerings of javelin throwing technique.

At that time, B. Schlokot, Germany, had already beaten 210 ft., R. Degland, France, had done 218 ft., and we had heard rumours of a remarkable young New Zealander. This was Stanley Lay (Plate 41, *et seq.*), whom I met for the first time a week or so before the A.A.A. Championships, which served as Olympic Trials in 1928. Lay, who had always been a pretty "snappy" cricket ball thrower, had taken up javelin throwing in 1925, but never bettered 130 ft., until he competed against an American team on tour in Australasia. He then adopted

the American hop finish and pulled out 206 ft. in 1927. On his arrival in England he competed at an L.A.C. Meeting and produced 202 ft. He asked me to criticise his style, and I did so. During the next week we worked together at Battersea Park, and he proved an intelligent pupil. I could see from the way things were shaping that a new British record was about due and had hopes of Olympic laurels for him.

At the A.A.A. Championships he did well in the preliminary trials and asked for a tip for the final. I suggested that he should use more palm lift and keep his left shoulder up. He did both these things in his next throw, which was 222 ft. 9 ins., just over 10 ft. better than Bela Szepes's British record made in 1927, and less than 7 feet behind the world's record of 229 ft. $3\frac{3}{5}$ ins., established by the Finn, Eino Pentillä, at Viborg, Finland, October 8th, 1927.

At the Olympic Games, 1928, no fewer than nine of the twenty-five competitors beat 200 ft., but it was an all-Continental final, with the world's record holder placed sixth and the British record holder seventh. E. H. Lundqvist, Sweden, with his very first throw, won the contest and broke Olympic record with a throw of 218 ft. $6\frac{1}{4}$ ins., then came B. Szepes, Hungary (No. 2, Plate 39 and No. 2, Plate 44), 214 ft. $1\frac{1}{2}$ ins., O. Sunde, Norway, 209 ft. $10\frac{3}{4}$ ins., P. Liettu, Finland, 209 ft. $6\frac{1}{2}$ ins., B. Schlokat, Germany (No. 3, Plate 39), 208 ft. $0\frac{1}{4}$ in., and E. Pentillä, Finland (No. 1, Plate 44), 207 ft. $4\frac{1}{2}$ ins.

Pentillä, I feel, was extraordinarily unlucky, for he got in one perfect throw, which soared well over the box marking the 230 ft. distance, but he just touched the scratch line with his foot, and so was given a "no-throw." He has an amazingly fast approach run and introduces two huge bounding strides at his check marks, the like of which I have never before seen.

Javelin throwing, as the reader may know, takes place from behind a 12 ft. scratch line marked upon the ground. The weapon is 8.5 ft. in length and must weigh not less than 800 grammes (1.6 lb.). If the reader finds that these weights do not correspond, that is not my fault; I give them as stated in the Rules Book of the International Amateur Athletic Federation.



PL. 39]

THROWING THE JAVELIN.

1. Demonstrating the final arm extension before the transition to throw.
2. Bela Szepes, Hungary, showing transition to throwing position.
3. B. Schlokat, German Record holder, beginning actual throw.
4. E. Lemming, Sweden, showing shoulder twist and right leg thrust.

Sport and General, Hungarian, German and Swedish Official. [S 260

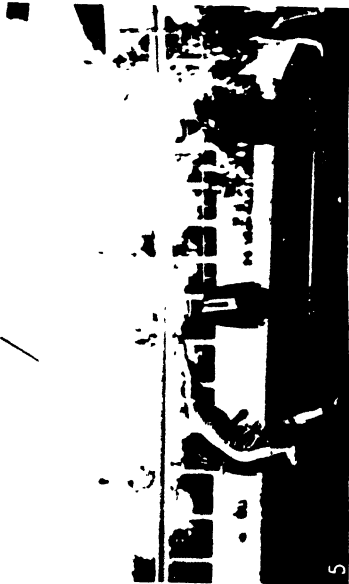

5



6

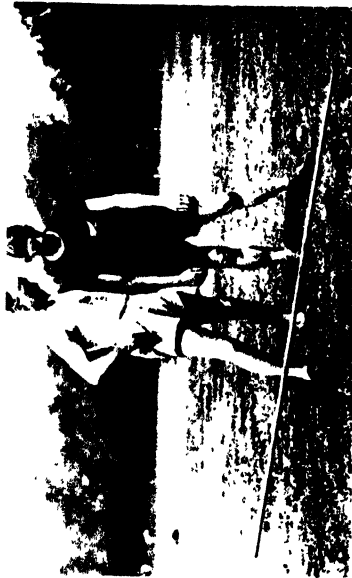

Pl., 40]

THROWING THE JAVELIN.

Sport and General. [S 261

5. The delivery, J. Myrta, Finland. Note good follow through and leg resistance. 6. The reverse, F. A. M. Webster, English Champion, 1911 and 1923. Note steady flight and true path of javelin. 7. Relaxing in balance, J. Saari-to, Finland. 8. Correct angle of javelin landing. The author and S. Lav, N.Z. Note Lav's exceptionally long arms.

The javelin has about the centre of gravity a whipcord binding 16 centimetres (6.3 inches) broad with a circumference not exceeding 25 millimetres (.984 inches). By this binding the thrower is required to hold the weapon, which, of course, has a sharp steel head.

The first thing the novice must learn is how to hold the javelin. This hold is of great importance. The whipcord binding must lie diagonally across the hand, passing over the root of the index finger and the centre of the heel of the hand. Sketch A in Fig. 27 shows the javelin resting in the correct position on the palm of the open hand. When the hand is

closed, as in Sketch B, the last joints of the thumb and fore-finger must grip the back edge of the binding. In fact the last joint of the index finger is actually behind the binding, pressing against the wooden shaft; the other fingers hold the binding but do not grip it. They are so disposed to prevent the point of the javelin from tipping up and to give the weapon direction. The manage-

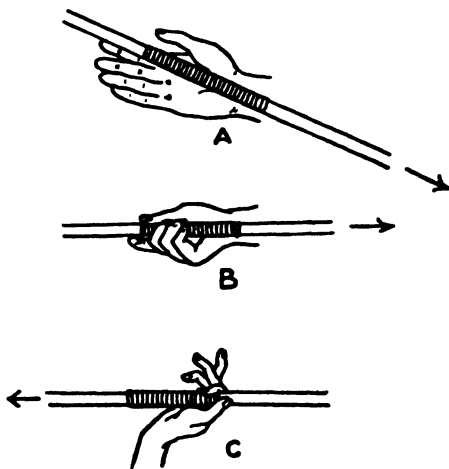

FIG. 27.

ment of the second, third, and fourth fingers is both difficult and important. They must relax their grip as the throw is made, so that the force of delivery comes from the thumb and index finger push and the final palm lift. If the three remaining fingers are not raised as shown in Sketch C, the javelin will be bent into a whipping flight and may actually be pulled downwards instead of being given its proper elevation in flight. At the same time the fingers must not relinquish their directional control too soon, or the head of the javelin will cant up before the weapon leaves the hand, and it will not fly

through the air in the direction of its own length as it should do.

The recommended starting position for the throw in the Scandinavian style is shown in Fig. 28, page 263. The reason the point of the javelin is held so much downward is to counteract its tendency to tip up when the throwing arm is drawn back. As will be seen from the diagrams in Fig. 29, page 264, depicting the footwork, the athlete stands facing squarely to the direction in which he is going to throw before he steps off to start his run up. During the run the shoulders should be kept square to the front until the arm is drawn back for the throw ; and, right from starting point to delivery, keep the javelin in line with the direction of its proposed flight, since a large percentage of throwing success lies in the thrower's ability to transmit his strength to the javelin in its longitudinal direction, so that it follows the path of its own length in flight.

Apart from the dynamics of javelin throwing there is this consideration for straight throwing—that all throws are measured perpendicularly to the scratch line, or the scratch line produced, so that a man who actually throws 130 ft. but lets the javelin break even 5 degrees sideways instead of throwing it at right angles to the scratch line, will lose nearly 5 ft. when the measurements are made perpendicularly to that scratch line.

The run-up should be formed in exactly the same way as that laid down for the use of long jumpers (see Chapter XVI). The scratch line, however, must not be treated as the take-off. It is assumed that the athlete will throw with his right hand. In which case the take-off mark is put down 9 ft. in rear of the scratch line, and it is from that mark that the athlete must work in forming his approach run. Nearly all the best throwers

cumulative effect and the athlete be at his maximum speed in the transition from the run-up to the throwing stance. The speed must be built up gradually and in proportion to the throwing ability, and should never be so great that the man has not perfect control over all his movements. The whole secret of success is to execute the throw *with* the run and when at top speed. There are, however, very few athletes who master this phase of the sport, merely because they will not take enough pains to practise it. That is why one sees so many men sacrificing all their running speed in a sudden check, or series of hesitation steps, when they are about to throw. The run-up must be straight ahead, and every effort should be made to check the tendency of the left leg to stretch out in a giant stride and to swing out to the left when the left foot is finally stamped down to secure the throwing position. The more walk-like the position of the thrower when he makes his throw, the better will be the result achieved. The run should be light and springy and consist of a series of short, quick steps.

In the Scandinavian style the thrower takes up his position at the standing start line, which may be as far back from the running start line ("Check No. 1" in the first of the three diagrams in Fig. 29), as it takes him to work up to about three-quarters speed. Fig. 28 shows the easy, upright pose from which the run starts. The javelin is carried in the position shown until "Check No. 2" is reached. As the left foot strikes No. 2 check-mark the speed should have been worked up to maximum for the transition to the throwing position. On the stride marked L1 the right (throwing) hand begins to direct the javelin straight backwards over the shoulder. The drawing back movement is made smoothly so that the arm is fully extended backwards and the body turned to the right, as shown in the demonstration position (No. 1, Plate 39), when the left

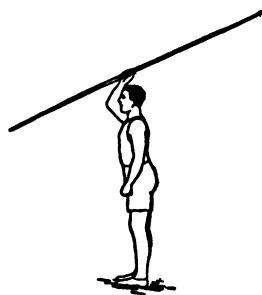

FIG. 28.

foot is at L2 and the right foot at R2. This is shown also in the "Scandinavian Orthodox style" (Fig. 31).

In the next movement, which is the transition to the throwing position, the body drops back with right knee well bent, the left arm is raised in balance, the right hand lifts the whole javelin shaft, and the left leg swings forwards. If the left leg is raised a little, in time with the lifting of the javelin, so much the better. (See Picture No. 2, Plate 39, of Bela Szepes, Hungary,

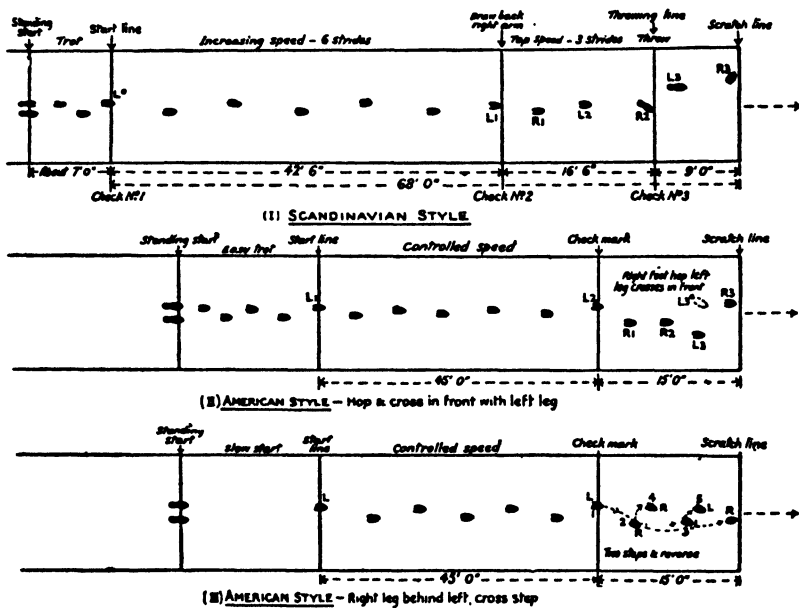

FIG. 29.

former British record holder.) Just before the left foot is stamped hard down at L3 the shoulders prepare for a very strong twisting movement from right to left, and the right hand is turned back on the wrist to bring it to a palm upwards position, which, with the bending back of the right arm at the shoulder and elbow, brings the javelin shaft level with the head and directly over the shoulder. The bending back action is beautifully demonstrated by the German champion, B.

Schlokat, in Picture No. 3, Plate 39. Notice how the inclination of the head is helping the whole body and arm bend and also that the point of the javelin has not been allowed to tip up. Observe also the strong leg spread and firm foot position.

With the left foot down, all the thrower's strength should go into the effort of twisting his shoulders from right to left to start the throw ; at the same time the right hip is forced round and up, the legs attain a walk-like position, and the right leg begins to push the body forward. The throwing arm is not, however, brought forward as yet, but the head must be bent back. All this part of the action is shown in Picture No. 4, Plate 39, of Eric Lemming, Sweden, Olympic Champion, 1906, 1908, and 1912, and former world's record holder. Note in Pictures 2, 3, and 4, Plate 39, the cycle of left arm action. In the picture of Lemming the left arm has reached the low point hip level position it will hold while the throw is made. Other points to observe are that the left leg is stiffening up to form a point of resistance and that the left shoulder has not been dropped below the level of the right. In the next action the right elbow swings in close to the ear and so is directly ahead of the hand which at once carries the javelin to the highest possible point directly above the shoulder. At the same time the legs and body are forcibly extended upwards and forwards, the whole left side is stiffened, the fingers are opened fanwise (see Fig. 27 C), the thumb and forefinger give the javelin its final impetus, and the palm pushes the weapon upwards into the air.

The two sketches in Fig. 30 show (1) a good, and (2) a bad finish position, because thrower No. 2 has dropped his left shoulder, allowed his left knee to "give," and is breaking to the left away from his work. Picture No. 5, Plate 40, of Jonni Myrra, Finland, Olympic Champion, 1920 and 1924, American, Finnish and previous world's record holder, shows the proper arm, shoulder and body follow through, with full left leg resistance. Observe also the rotation of the throwing arm from left to right to give the spear a rifling spin.

Athletics of To-day

In making the throw it is absolutely necessary that the right shoulder be pressed quickly and strongly upwards and forwards with the body, so that the force from the legs is continued in a straight line forwards and upwards. The thrower must keep well on to his work—that is, force his body to the right in the delivery. If he breaks to the left he cannot support the throw

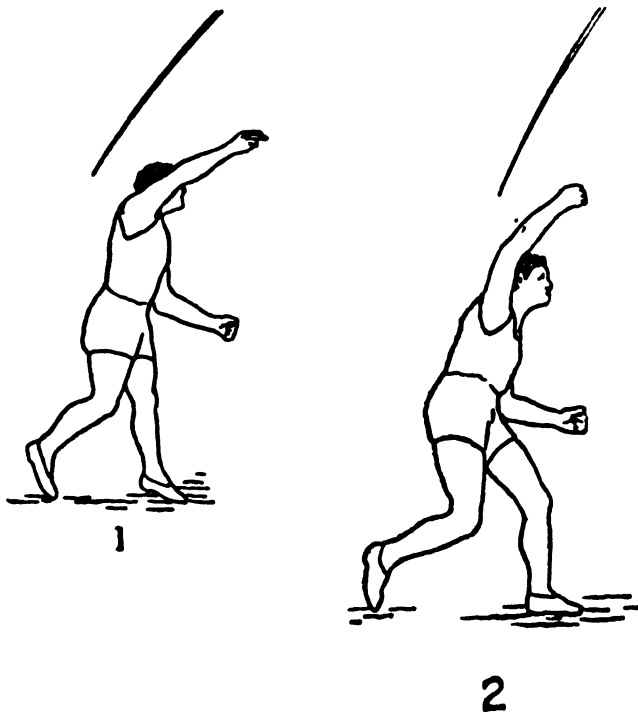
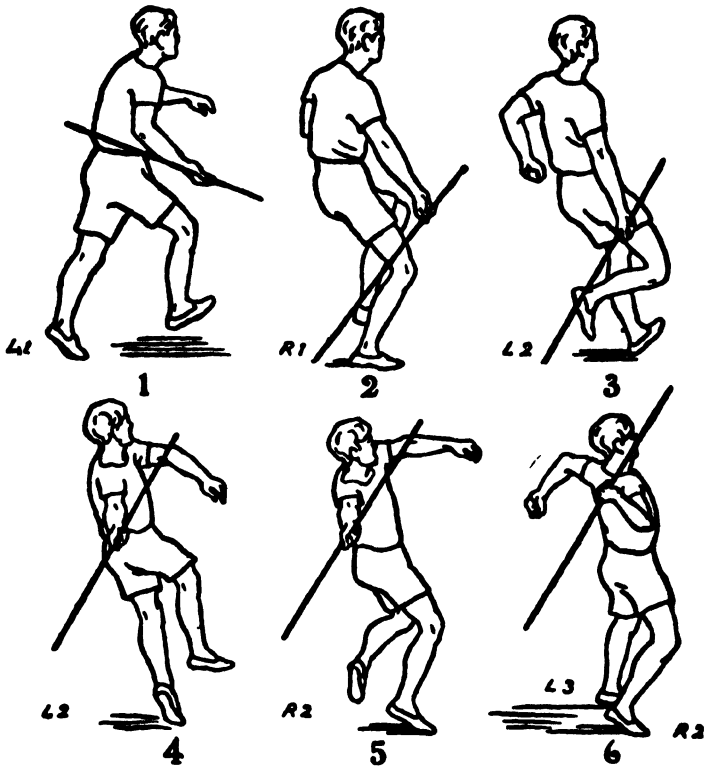

FIG. 30.

from beneath and will be throwing to the side instead of over the shoulder and will lose much power.

A strong arm bend followed by the pressing up of the right shoulder under and after the javelin, as Myrra is doing, gives the javelin a tendency to elevate after it has left the hand; it will then reach maximum height a third of the way through its flight and will lie horizontally in the air until the



Some impressions of Jonni Myrra

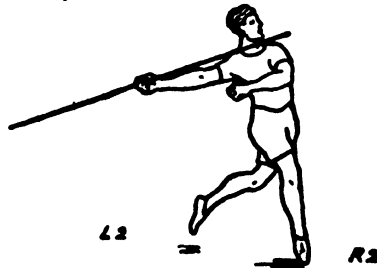

Scandinavian Orthodox Style

FIG. 37.

force of gravity and its own diminishing velocity combine to bring it to earth.

Pictures Nos. 6 and 7, Plate 40, show the breaking-up process after the javelin has left the hand. Some men need as much as 9 ft. space for breaking up if they are not to overstep the scratch-line. No. 6, I think, fully emphasizes the force employed and shows incidentally the javelin in good, even flight along the path of its own length. It shows also the way in which the right and left legs change places in the reverse which comes soon after the javelin has left the hand and brings the right foot to R₃, in Fig. 29. In No. 7, Plate 40, J. J. Saaristo, Finland, Olympic Champion, 1912, and former world's record holder, displays perfect harmony in counterbalance between arms and legs and a fine, easy relaxation of all the muscles, which should follow as soon as possible upon the delivery.

No 8, Plate 40, shows the angle at which the javelin should enter the ground. If it pitches more steeply we have the case of the rolling-over long jumper once again, and the spear has either dropped steeply and thereby lost distance, by being thrown too high, or it has expended, in burying its head deep in the ground, force that should have been used up in its passage through the air. This wastage is probably due to the javelin being given insufficient horizontal palm lift. The correct angle of upward and forward flight is one of 45 degrees.

Jonni Myrra, in his time, introduced an entirely new movement into the Scandinavian style of javelin throwing, the main part of which style, however, he used. The difference came just before the transition from the run to the throw. It was that, whereas the Scandinavian style proper requires the javelin to be carried back *over* the shoulder in the steps L₁, R₁ and L₂ (Fig. 29), Myrra introduced an under-hand swing to get his throwing position. As his left foot landed at L₁ he used to bring his right arm down from the "hand above the shoulder javelin carry" position, with a forward swing, so that it dropped level with his right knee as his right foot was grounded

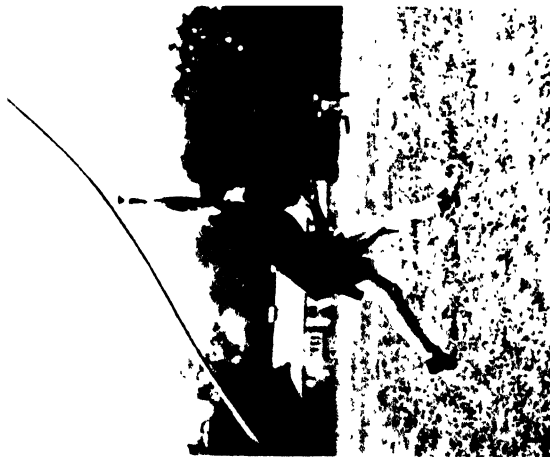

Pl. 41

1. The correct vertical position of the arm at the moment of releasing the javelin is well shown, but the body has broken away to the left



Spot and General. [S 268

—The Delivery.

3. A fine follow-through action. Note the leg resistance and twist of right hand



THROWING THE JAVELIN.

2. Correct delivery finish with body well on to its work, good right leg drive and left

leg resistance, but the head is working away from the throw.



PL; 42]

4. Completion of the follow-through and commencement of the forward breaking-up reverse of the feet. Thrower is just rising on toes of left foot.



THROWING THE JAVELIN.

BREAKING-UP.

5. The "carry through." Toes of stiff left leg are acting as the fulcrum of swing forward, and right arm has followed right through to left hip.



Sport and General. [S 269

6. The "reverse." As the left foot completes its fulcrum function the right leg goes forward with a high pick up of the knee. Left arm rises in balance.

at R1. As the left foot came forward to L2 he would sway his whole body to the left and begin to bring the javelin to the rear with a backward under-arm swing. He then performed a high step-over action with the right leg to R2 as he got his throwing arm fully extended behind him and so had his body well turned and bent back and his knees deeply flexed when the left foot was stamped down at L3.

The half-dozen impressions of Myrra at work (Fig. 31, page 267) may help the reader to understand his form if he will compare the sketches with that of the Scandinavian orthodox style and with the make-up of Fig. 29 (1), page 264.

Eino Pentillä, the present world's record holder, and also a Finn, has adopted the Scandinavian style, plus Myrra's under-hand forward and backward swing and has added to the whole a special "stunt" of his own. In the first place, he has the most furiously fast run-up I have ever seen a man hold and yet still throw in good shape. He keeps his javelin arm swinging backwards and forwards as he runs, thereby gaining a compensatory shoulder swing and considerable traction. Half-way through his run he gets in one huge bounding stride and just as he comes to "Check 2" (see Fig. 29, 1) he gets in a second bound and at the same time puts Myrra's under-hand forwards and backwards swing into action. This brings him to his set throwing position at R2 and L3, and he throws with terrific speed and jerk, but needs a lot of space to break up in in his reverse.

The two American styles supply a totally different form of javelin throwing except that the Americans have adopted Myrra's under-hand swing in a modified form. Their methods derive, I fancy, from the circumstance of the shot putters being the first American athletes to take up javelin throwing. The late Ralph Rose, former holder of the world's shot putting record, was, it may be remembered, the winner of the first national javelin throwing championship held in America in 1909, when he reached 141 ft. 7 ins. Naturally enough, the shot putters wanted to introduce into the new game as much of their own particular technique as was practicable, and, even

Athletics of To-day

after twenty years, American javelin throwing still smacks of the shot putter's art. Some few of the Americans use the over-shoulder-carry, shown in Fig. 28, but the majority prefer an under-shoulder position for the arm during the approach run. Fig. 32 shows the manner in which the javelin is held under and along the line of the throwing arm, with the back of the hand uppermost and the head of the weapon level with the athlete's chin. About 20 ft. behind the scratch line the javelin point is dropped so that the shaft comes parallel to the ground and as the left foot strikes the athlete's throwing line in (I) Fig. 29, and "Check Mark" in (II) and (III), Fig. 29, the body is leaning

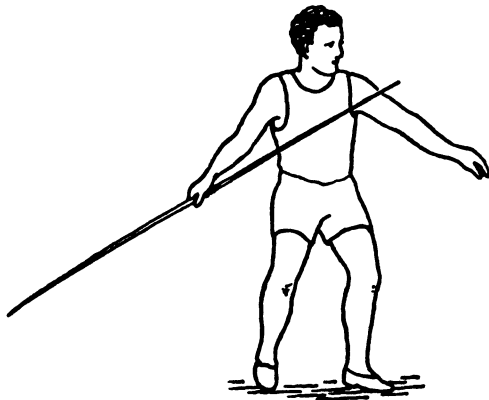

FIG. 32.

well forward and the weapon is back at the full stretch of the throwing arm. See Picture No. 3, Plate 44, which shows Lord Burghley in a rôle that will be unfamiliar to many of his admirers.

From this point the two American styles vary. In the one shown in Fig. 29 (II), "Hop and cross in front with left leg," the right foot is put down at R₁, the right arm is rotated backwards, so that the palm comes uppermost and the shaft of the javelin lies along and above the arm and the point comes level with the chin. Simply turn the hand palm uppermost to reverse the arm position shown in Fig. 32. At the same time the left arm is thrown across the body and the head bent back. The athlete then hops on the right foot to R₂ and the left leg is swung either to L₃, or L_{3a}, which is an alternative position, shown by a dotted line. The transition swing of the left leg while the right leg completes its hop from R₁ to R₂ (Fig. 29, II) is shown in the accompanying sketch

(Fig. 33). The actual delivery is made in the Scandinavian method.

In the other American method (Fig. 29, III), "right leg behind left, cross step," the right foot is placed in behind the body just as the body is bent back to commence the throw. This step was first used by Eric Lemming.

S. Lay, New Zealand, who holds both Australasian and British records, uses the American method, numbered (II) in Fig. 29, but places the left foot down at L3. The six pictures in Plates 41 and 42 show Lay's sequence throwing action.

In Plate 41, No. 1 shows the correct "walk" attitude of the legs at the moment of delivery and a properly perpendicular right arm release. The thrower's body form, however, is very poor. There is too much forward lean, the left shoulder has been dropped and the head bent to the left, thus dragging the body away from its work, while the wavy line of the javelin

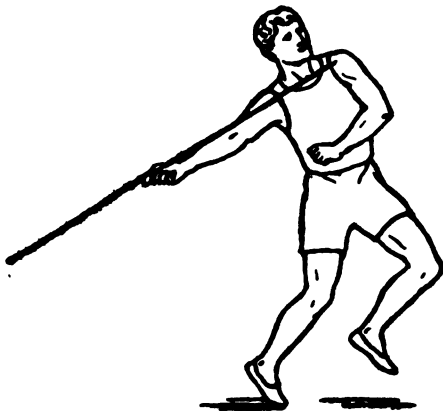

FIG 33.

indicates a faulty release in which the fingers have been allowed to put downward pressure upon the javelin instead of the palm giving the weapon its proper final release lift.

No. 2 portrays an almost perfect delivery, with the javelin wonderfully steady in flight and following the path of its own point. It is, however, tracking out to the right instead of sailing straight ahead, because the thrower has broken slightly to the left and away from his work, and the throw has not been made completely over the right shoulder. Observe the position of the right hand, which proves that a good final twist and finger flick has been employed to polish off the delivery, which has given the weapon a rifling flight.

Athletics of To-day

No. 3 portrays the finish of a perfect throw. The "walk" action of the legs has been properly preserved, the left leg is well stiffened to form a column of resistance, and there is complete follow-through of the whole right side, shoulder, arm and hand. The body is not quite as fully on to its work as is Myrra's in No. 5, Plate 40.

In Nos. 4, 5, and 6, Plate 42, depicting the breaking-up process, the foot fulcrum work of the stiffened left leg, and the follow through of the arm and body are admirably shown, as is also, in No. 6, the right knee pick-up action as the right leg goes forward to complete the reverse.

The three pictures forming Plate 43 indicate methods whereby two athletes may teach each other the throwing action. These were taken in the week preceding the English A.A.A. Championships, 1928, when Lay and I were working together. In No. 1 the athlete acting as instructor demonstrates a correct position against the other man's pull on the javelin tail, and the man acting as pupil imitates his movements. No. 2 shows how the instructor "sets" and adjusts the pupil's position and controls the pull upon the javelin. The points being demonstrated are shoulder squareness and level height, and the fault of allowing the javelin point to tip upwards, as the instructor is making it do. No. 3 shows the way in which Lay was temporarily cured of dropping the left shoulder by having his left elbow pressed up, as the javelin was raised to correct delivery height directly above the right shoulder, with the body held upright. Again, the fault of allowing the javelin head to rise at too steep an angle is being emphasized. By this system of co-operative training Lay added more than 20 ft. to this throw in a week.

Athletes employing the mutual coaching system should watch for the following faults in one another :

1.—The head of the javelin is tilted up during the run (Scandinavian style), or cants up during the throwing action.

2.—The running steps are not quick and springy and the speed is not cumulative.

3.—The arm is not drawn smoothly back over the shoulder, or is kept too long at stretch before the throw begins (Scandina-



P.L. 43]

(1)



(3)



Sport and General. [S 272

(2)

THROWING THE JAVELIN.

TEACHING TECHNIQUE.

1. The commencement of throwing position.
2. Getting the shoulders square. Lay's left leg has got into a bad position. position and angle of javelin which is pointed too high. Lay should not be looking down.
3. Correcting the delivery



PL. 44]

Sport and General [T 273

THROWING THE JAVELIN.

1. Eino Penttila, Finland, World's Record holder, 229 ft. 3 3/4-in. 2. Bela Szepes, Hungary, runner-up at Olympic Games, 1928, 214 ft. 1 in. 3. Lord Burghley, Great Britain, showing under-arm carriage of javelin. 4. K. Shimiyoshi, Japanese Record holder, throwing 202 ft. for Waseda University v. Achilles Club. His body is breaking badly to the left.

vian style). Conversely, it should be noted that there should be no break or pause between the arm reaching its fullest backward extension and the beginning of the throw.

4.—The throw is not started with a strong enough twist of the shoulders from right to left. The shoulder twist must be built up with appropriate body twisting from the hips exercises. There are some useful ones in Muller's System.

Faults to be watched for in all Styles.

5.—The javelin point is directed to the side instead of straight ahead in running and throwing.

6.—The body has passed the perpendicular forward before the delivery is made.

7.—Body breaks away from the javelin to the left. In other words, the left leg and side are not properly stiffened.

8.—Legs, body and shoulders do not support the throw from beneath.

9.—Javelin is not drawn forward over the shoulder with the elbow leading.

10.—The throw is hurried and the feet are reversed as the throw is being made and before the javelin leaves the hand.

11.—The left leg is bent at the knee instead of being properly stiffened as the throw is made.

12.—The feet are too widely separated in the throwing position.

Neither strength nor speed is the prime essential of success in javelin throwing. "Gunnar" Lindström, who threw over 218 ft., did not use nearly as fast an approach run as Pentillä, and I doubt if either man is as muscularly strong as Dalrymple. Suppleness and the ability to co-ordinate all the muscle movements and actions of throwing are the real factors of success.

In a throw of over 140 ft. the javelin is given an initial velocity of 67 ft. per second and since the weight of the weapon is known to be 1.6 lb. the energy of its progression, *i.e.*, the force exerted by the thrower, can be calculated. It is roughly 60 foot-lb. The work done in throwing the javelin does not fall

entirely upon the muscles of the arm, but is transmitted down that limb by a jerk, which is caused by the sudden checking of the body and shoulders as the left foot is planted and the left leg is stiffened in the final throwing position. This action may be compared to that of a huntsman cracking his whirling whip, the power travelling from the checked hunting crop along the thong and exploding in the thin whip-cord lash. In both cases it is concentration of energy which produces the jerk which causes the whip to crack and the javelin to depart. The javelin thrower's approach run and transition arm swing compare to the huntsman swinging his whip round his head, and the check which causes the jerk is introduced at the exact instant when he reaches his throwing line. Smoothness of action has been given as an ideal to aim at, but there must be "jerk" also, for no human muscles could produce without it anything like the velocity with which the javelin is projected. During the final throwing effort some part of the arm is travelling at only a little less than the throwing velocity, which is actually attained by the hand (whip-cord in theory) at the instant the javelin is released by the fingers.

To get a successful throw every movement must fit into the next one; the javelin must be released at exactly the right second, and the jerk must be concentrated at precisely the proper point—and that point is at arm's length directly above the right shoulder. At this stage the muscles and nerves are co-ordinating to thousandths of a second. The speed is too rapid, I believe, for mental control. The process, and the success, is one of muscular remembrance, and the ability of the nervous system to recollect and repeat the sensations it has received from the muscles during the training period. Discipline and drill have been at the back of most epic stands recorded in military history. The soldiers who made them had learned to force heart and nerve and sinew to serve their end long after they were gone—if one may paraphrase Kipling. In the same way the athlete can, by long practice (slow at first but increasing in speed as fitness comes and skill is developed) in performing and co-ordinating his movements, so impress the actions upon

the muscles and nervous system that the actions can, in time, be performed at incredible speed.

Take, for example, B. Schlokat, the German record holder. Up to 1926 he had enjoyed no signal success. In that year he beat 183 ft. and then stuck fast, because, I fancy, he preferred to go on slowly building up his technique instead of bothering after a further immediate increase in distance. Consequently the nervous system became accustomed *gradually* to a series of faster and deeper sensations, and in 1927 Schlokat did just over 212 ft. He achieved an improvement of nearly 30 ft. in less than a year by patient perseverance and painstaking practice.

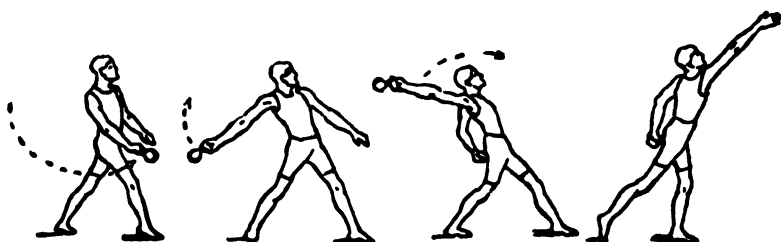

FIG. 34

The case of Lay's improvement of 20 ft. in a week may be held to refute the above contention, but it does not. Lay's improvement was like the "knowledge" we used to stuff into our heads at the last minute for the purpose of answering examination questions. As soon as the exams. were over our brains cast out the memorised but undigested facts, just as Lay's nervous system accepted slight variations in style when these variations were made under supervision, but could not recollect the muscular action when there was no mentor at hand to keep on correcting faults until such time as the style was well worked in.

I often think that we pay all too little attention to the development of the particular event we practise and consequently do not use sufficient contributory exercises. For example, strength in Myrra's under-hand swing action

might be considerably increased by a practice exercise with a shot attached by a swivel to a triangular handle. One might start with a 5lb. shot and work up to a weight of 12lb. to 14lb. The exercise would be carried out as shown by the four figures in Fig. 34 on page 275.

Then, again, some very good work can be done with a chest expander, turned to one's own uses, and also with those elastic strand "developers" which one fixes to the wall. The delivery punch, or jerk, is, I believe, best acquired with a punch ball of the type that is suspended from an overhead platform. A glove should be worn and the ball struck with the side of the fist nearest to the little finger, in the same action as is used in throwing the javelin.

TRAINING

The system of training will be best explained perhaps by a brief personal reminiscence. When I went into training under the late S. A. Mussabini in February, 1924, he kept me at two tasks for a number of weeks. My job was to take long walks and chop wood with a heavy, long-hafted axe. I had been throwing 130 ft. to 140 ft. in the autumn of the previous year. Although I hated walking and the chopping made my hands sore and my back ache, I stuck it out, but I wanted badly to begin throwing again. In the second month "Sam" sent me five-mile runs with instructions to "shack" along on my heels with every muscle loose, and he gave me a 16 lb. hammer and a shot to play with.

When the real work started I did half an hour's fast walking at 7 a.m., followed by a cold shower and breakfast. After 11 o'clock I was allowed to hop, skip, sprint, jump, and pole vault or hurdle. Between 3 and 4 p.m. I did light throwing *for style only*, and the trouble old Sam took over that phase was simply amazing. He made diagrams on the ground, in the air, and on paper. He took photographs and made sketches, timed everything with a stop-watch, and finally brought along a cinematograph machine. After supper he was all in favour of

a three or four miles stroll ; and bedtime, in a warm, quiet, well ventilated room, came at 10 o'clock to the very tick.

In April I was asked to do a lecture tour of the Provincial Universities and, much against Mussabini's wishes, I agreed, mainly because I thought we might find a good deal of Olympic talent in that quarter. On that trip I did 156 ft. at Manchester University, 168 ft. at Liverpool, and 176 ft. 8 ins. at Cardiff, so there was evidently quite a lot in Mussabini's methods, but my folly in not following his advice cost me very dear. For in demonstrating discus, javelin, shot, jumps, pole vault, and hurdles almost every day for three weeks I fairly wore my arms and legs out. In fact the muscles went so dead that I don't think they've ever fully recovered their elasticity.

One great training stunt of Mussabini's for improving pulling and throwing power consisted of my walking about the field and continually throwing the javelin down into the ground about 20 ft. ahead of me. He made me execute this sort of throw from a full backward extension of the throwing arm and in such a way that the body was brought well under the javelin in an erect position while throwing. The arm was fully extended backwards with a strong bend of the side to get length into the pull and also in order that the power might go into the javelin in the direction of its length.

I did a lot of throwing with three steps only, a lot more with a slow run, and I practised the approach run until you could have chalked the track and I would have hit the same foot marks twelve times out of every dozen. And that is the only way that the big successes come, by patience, perseverance, and methodical practice under proper supervision.

My diet, incidentally, was everything I fancied that was not too rich or spiced, and I got a tankard of beer with my lunch and another with my supper. Since I am a heavy smoker I was allowed three pipes a day—that is, one after each principal meal, and I think I enjoyed those three daily pipes more than any others I have ever lit.

CHAPTER XX

THROWING THE DISCUS

DISCUS throwing was a standard event at the Olympic Games of ancient Greece and formed part of the pentathlon. Apart from competitive sport, the ancients regarded discus throwing as among the best of their remedial exercises. Homer mentions the sport repeatedly, and Ulysses appears to have been "world's record holder" in those days, according to the *Odyssey*. The use of the discus is fully described by Statius in *Thebais*. But what weight and size of missile the ancients used and the manner in which it was thrown are matters which cannot now be accurately determined.

There are in the British Museum specimens of discoli found by excavators which lead one to believe than an average discus was some 8 or 9 inches in diameter and weighed between 4 lb. and 5 lb., in which case it was a very similar implement to that in use to-day, which has a diameter of $8\frac{1}{2}$ ins. and weighs 4 lb. 6.4 ozs.

In the British Museum there is also a restored copy of Myron's Discobolus (No. 1, Plate 45), a statue of a discus thrower in the act of delivering the throw. Mr. N. E. Norman Gardiner, however, who went deeply into the matter, has suggested that the restorer adopted a wrong attitude for the figure. The reader may judge of the matter for himself, by comparing the pictures Nos. 1 and 2, Plate 47, and by perusing this chapter. My own humble opinion is that the statue has not been wrongly reconstructed, but that Myron's conception and the meaning of the pose of his discus thrower have been misinterpreted by modern generations. I am further of the opinion that Myron meant to depict his man at the commencement of the turning

movement, as shown in No. 2, Plate 45, which is a main feature of the modern and logical method of slinging the missile out from under the hand in what is known as the free style.

The Olympic Games, after remaining uncelebrated for upwards of fifteen hundred years, were revived at Athens in 1896 and a Free Style Discus Throwing event was included in the programme. To this, however, I will revert a little further on. Between the revival of the Games in 1896 and the holding of an intercalated series, also at Athens, ten years later, antiquaries and others had been worrying away at the history of the sport, and in 1906 there was added to the Olympic programme an event in the Classical, or Hellenic, style.

For this competition a rectangular pedestal $31\frac{1}{2}$ ins. long and $27\frac{1}{2}$ ins. broad, with a height of 6 ins. at the back and 2 ins. at the front (towards the direction of the throw) was provided for the athlete to throw from. The thrower took his stand upon this pedestal, with feet separated, right foot in advance, and the discus held between his hands. The discus was then raised straight above the head by both hands, as shown in picture No. 3, Plate 45, of Martin Sheridan, U.S.A. When the arms were at full stretch above the head the whole trunk was turned to the right, without, however, altering the position of the feet, save for a lifting of the left heel. The body was then bent sharply forward, the left hand releasing its hold as it reached the right knee and the right hand swinging the discus up as far to the rear as the build of the shoulder would permit, all exactly as shown in Myron's Discobolus statue (No. 1, Plate 45). The rules, still adhering faithfully to the statue, required that at the moment above mentioned, "the right foot should be forward and both legs bent, the right foot resting full on the sole and the left on the toes only." From this pose the thrower delivered the missile forward by a sharp and simultaneous extension of his whole body. Sheridan is seen in the execution of this action in picture No. 4, Plate 45. The thrower was permitted to leave the pedestal at the moment of throwing. This reads, no doubt, like the description of a very simple series of evolutions ; but, in practice, it proved about as difficult

to judge this event as it is to judge fairness in a walking race, and Heaven knows that is hard enough.

At Athens the only competitor who really knew what was required of him was Georges Georgantas, Greece, who won another odd event—throwing the stone, which was a young boulder. W. Jarvinen, Finland, won the Hellenic Discus Throwing event at 115 ft. 4 ins. from Georgantas, 107 ft. 7 $\frac{5}{16}$ ins., two very fine efforts from what is nothing more or less than a standing-throw position. Martin Sheridan, U.S.A., who won the Free Style Discus Throw and also the Shot Put, was eliminated for an irregularity in style and just after the meeting that great American critic, the late James E. Sullivan, wrote: "The authorities (Olympic) should frame laws that would be international. They should have drawings made so that the different officials in every part of the world may be able to decide according to the Greek rules."

That suggestion was sound common-sense, but it has taken almost a quarter of a century for it to sink in, for it was not until the Ninth Congress of the International Amateur Athletic Federation was held at Amsterdam in July and August, 1928, that the Federation decided, subject to a further study of them by the German member, to add the rules for Throwing the Discus, Hellenic Style, to the athletic rules of the I.A.A.F.

Meanwhile the Classical, Hellenic, Greek or "As at Athens" style was again included at the Olympic Games of London in 1908. British trials were held in May when the late H. A. Leeke, C.U.A.C., and L.A.C., proved himself the best of our men with a throw of 98 ft. Martin Sheridan, however, was due to come into his own. Born in Co. Mayo, Ireland, in 1871, he had taken out American naturalization papers in 1897. He was a fine-looking man, standing half an inch under 6 ft. and weighing just on 13 stone. He was the best discus thrower in the States, more than useful with the shot and hammer, and had won the American individual all-round championship title in 1905 and 1907. In London he won the Free Style Discus Throw by less than a foot and the Greek style, as shown in Pictures Nos. 3 and 4, Plate 45, at 124 ft. 8 ins.

Throwing the Discus

281

In the same year that the Games were revived at Athens in 1896, when R. S. Garrett, U.S.A., won the Free Style Discus Throw at 95 ft. 7½ ins., a distance that many a schoolboy can beat to-day, Athletic Associations were formed in Norway and Sweden. The latter country held championships in 1896 at Halsingborg, where C. E. Helgesson won the discus event at 97 ft. 5 ins. In the following year C. Evenson became first Norwegian Champion. An American National Championship also was instituted in 1897, the throwing taking place from a 7 ft. circle, instead of the regulation circle of 8 ft. 2½ ins. C. H. Hennemann, Chicago A.C., won the title at 118 ft. 9 ins.

At the second Olympiad, Paris, 1900, a Hungarian named Bauer raised the record to 118 ft. 2⅞ ins., to which M. J. Sheridan, U.S.A., added nearly 11 ft. in 1904 at St. Louis. That was the first of his three Olympic wins for in 1906 at Athens, he reached 136 ft. 0½ in., and at London, 1908, with a throw of 134 ft. 2 ins. defeated by less than a foot M. H. Giffin, U.S.A. (American Champion, 1910, 135 ft. 6¼ ins.), and M. F. Horr, who had won the national title before leaving the States at 132 ft. 9 ins. The unlucky man, however, was big, blonde, 6 ft. Ville Jarvinen. He had recently set up a new world's record of 143 ft., but was so palpably nervous in the London stadium that he could not throw further than 129 ft. 4½ ins., which gave him fourth place, just half an inch behind Horr.

In America the National and Western Conference Champions were beginning to do big things, but the I.C.A.A.A.A. did not take up either this event or the javelin until 1922.

So far as Great Britain is concerned it is no exaggeration to say that none of us had seen a discus until that implement made its mysterious appearance just before the Olympic Trials in May, 1908. Every sort of style of throwing the missile was tried, but no one hit upon the smooth waltz turn movement to which the Scandinavians introduced us later on. E. Barrett, a very hefty Irish shot putter of the City of London Police A.C., won the trial at 107 ft. 2 ins., and with five others, who had not

Athletics of To-day

thrown as far, represented Great Britain at the Games in the following July. Of these six Britishers, W. E. B. Henderson and A. E. Flaxman alone caught on to the trick of throwing as it was practised by the best of the foreigners. Portraits and action photographs of these two great throwers illustrate this chapter.

In 1910 the Amateur Field Events Association was formed under the presidency of Sir Arthur Conan Doyle and controlled certain field events championships until they were taken over by the A.A.A. in 1914. W. E. B. Henderson took the first title in 1911 at 106 ft. 11 ins. and retained it in 1912, 128 ft. 4½ ins., and 1913, 117 ft. 0 ins. On each occasion Flaxman proved himself a very good second. The British native record made by Henderson in 1912 still stands unbroken, and I shall never forget the occasion of its being made. The championship was held on a small sports ground at Mortlake—long since, alas, covered with pretentious villas!—and Flaxman was pressing his old rival pretty hard, when Henderson suddenly produced a beauty. The discus went sailing through the air, over the enclosure ropes, and clean between the faces of two babies seated at either end of a twin pram. That throw was never approached until A. E. Flaxman reached 128 ft. 1½ ins. at the sports of the 59th North Midland Division at St. Albans in 1915. It says much, incidentally, for Henderson's fitness that he won the English (Native) A.A.A. Championship of 1923. On that occasion it fell to my lot to play the part of runner-up, Flaxman having fallen on the Somme in July, 1916.

At the fifth Olympiad held at Stockholm in 1912, Henderson was our only British representative, but by this time the Scandinavians had really got going, and although Sheridan had touched his high-water mark, 141 ft. 8½ ins. in 1911, America had found him a fine successor in J. Duncan, who threw 156 ft. 1¾ ins. in May, 1912. On this form it appeared highly improbable that Duncan could be beaten at Stockholm a few months later. There were, however, rumours running round Europe, and reaching even uninterested England, of a huge and

amazing Finn, named Taipale, who was said to be a good deal better than his great countryman, V. Jarvinen, even at the latter's best.

At Stockholm A. R. Taipale delivered the goods, but Duncan did not. There were again two styles of throwing, and Taipale, amazingly quick for his size and weight, broke world's record in one and Olympic record in the other. The Greek style was replaced at that Olympiad by a contest in which the competitor won who achieved the best total with both hands, that is to say, with his best right hand throw and his best left hand throw added together. In the best hand only style, the big Finn threw 148 ft. $3\frac{9}{10}$ ins., beating by nearly 10 ft. R. L. Byrd, U.S.A., J. H. Duncan, U.S.A., and his fellow Finn, E. Niklander, all of whom did just over 138 ft. It should be noted that A. M. Mucks, Wisconsin University, was sixth at 134 ft. $3\frac{3}{8}$ ins., for two years later he took the American Championship record up to 145 ft. $4\frac{1}{2}$ ins.

In the two-hands contest at Stockholm the form of the Scandinavians was extraordinary and well upheld their belief in developing both sides of the body simultaneously in sport. Taipale won (146 ft. $7\frac{1}{10}$ ins. right and 125 ft. $1\frac{1}{8}$ ins. left = 271 ft. $8\frac{1}{2}$ ins.), from Niklander (132 ft. $1\frac{1}{8}$ ins. right and 123 ft. $7\frac{9}{10}$ ins. left = 255 ft. $9\frac{1}{4}$ ins.), with Sweden filling third and fourth places. It is believed that just before the War broke out Taipale threw 158 ft. 11 ins. at Magdeburg, but things were in a state of chaos before the record could be considered, and so it never went on to the books, but I can well believe that it was fairly achieved and honestly measured, for I have seldom seen a finer specimen of manhood and never a better thrower than was Armas Taipale of the Suomi Club, Finland. Luckily he, like our own champion, W. E. B. Henderson, survived the War, through which both of them served.

Meantime Niklander had come on amazingly, and Sweden had produced O. Zallhagen (No. 11, Plate 49), who at Enköp, in September, 1916, had raised the Swedish best hand record to 150 ft. $1\frac{7}{8}$ ins.

Athletics of To-day

At Antwerp, England had only one entry, B. Howard Baker, who was in for the high jump and hop, step, and jump also, and, if my recollection serves me, he did not take part in the discus event. The others, however, had a great competition, in which Niklander, 146 ft. $7\frac{3}{10}$ ins., beat Taipale, 145 ft., with A. Pope, U.S.A., third, 138 ft. $2\frac{7}{10}$ ins. All three made their best throws in the eliminating trials, but Zallhagen, who was always a lethargic thrower, increased 3 ft. in the final and was placed fourth at 134 ft. 9 ins. That year P. Quinn, of the Dublin Police, took the A.A.A. title at 123 ft. $5\frac{1}{2}$ ins., Taipale having set the British record at 144 ft. $6\frac{1}{4}$ ins. in 1914.

Many people had regarded Duncan's record as a freak performance, never likely to be repeated; but the 150 ft. mark was now definitely in sight. Pope, although beaten at Antwerp, had made a Pacific Coast record of 152 ft. 7 ins. in 1920. In 1922 he was beaten by Tom Lieb, of Nôtre Dame (No. 3, Plate 50), at 151 ft. Pope was a tall, heavy chap who had developed a style entirely his own, and in learning it practised two or three hours every night on style movements alone.

In the same year Finland sent to England, Ville Niittymaa, who won the A.A.A. event at 136 ft. 7 ins. He was a short, thick-set fellow of exceptional strength and quickness, and I remember, while we were awaiting our turns to throw, he showed me his right hand—the ends of the fingers were hard with corns produced by the pulling spin he put on the edge of the discus. By the next year he had got his form worked right in, and at the international meeting in connection with the Gothenburg Exhibition, 1923, he threw 154 ft. $0\frac{7}{8}$ ins. I threw against him in England and watched him in Sweden, and the improvement a year had produced in his form was amazing, but typical of discus throwing, at which game a man may work for years with moderate results before the whole sequence of action knits suddenly together and the really big throws are produced. G. Steinbrenner, second to Niittymaa at Gothenburg (139 ft. $0\frac{3}{4}$ in.), was the first German to show real form.

In England that year no foreigners competed for the A.A.A. title which G. T. Mitchell, University of London, had the

extraordinary luck to win at 110 ft. 3 ins. In Ireland, however, P. J. Bermingham, a colossal Dublin policeman, who had been battling with P. Quinn since 1919, was gradually establishing the mastery ; while in America the I.C.A.A.A. had at last taken up the event, and Glenn Hartranft threw 158 ft. 1½ ins., while Clarence Houser beat 150 ft. The former did not get his record, because a high wind was blowing when the throw was made. Both these were big men, as was the Norwegian, Ketil Askildt (No. 10, Plate 49), who was also in the 140 ft. class. At Paris just before the 1924 Games, I personally measured a practice throw of Bermingham's of over 152 ft., but in the Olympic competition he was a dozen feet or more behind this, while Hartranft and Askildt also lost their form. Houser took the gold medal with a new Olympic record of 151 ft. 5⅛ ins., with Niittymaa throwing 147 ft. 5½ ins. for second place.

In 1927 Bermingham won his seventh Irish Championship, but was deprived of the English title he had held for three years by a comparatively small Hungarian, K. Marvalits (No. 2, Plate 46 and No. 9, Plate 49), who put up a new British record of 145 ft. 8½ ins. Bermingham, however, at the Leinster Championship of that year, took the Irish record up to 153 ft. 6½ ins.

In Hungary, Marvalits and Karl Egri, the latter a man of the Taipale build, both beat 150 ft. In America Clifford Hoffman (No. 4, Plate 50) did the same, and Houser increased the world's record to 158 ft. 1¾ ins., thus bringing even 160 ft. within the range of probable new records. Germany, too, so intent upon Olympic honours that she even went the length of importing an English professional golfer to teach her athletes swing, was making marked progress. The discus average of the best ten Germans of 1926, headed by H. Hoffmeister, 145 ft. (No. 5, Plate 48), and ending with E. Paulus, 129 ft., was 135 ft., but in 1927 Hoffmeister improved to 154 ft. 4 ins., Paulus had come up to third place, 145 ft. 7¼ ins., while Steinbrenner, tenth, reached 134 ft. and the average was raised to 141 ft. Hoffmeister in 1928 was said to have beaten 160 ft., but this was not officially confirmed, and Paulus, who had been steadily improving for

fifteen years, took the A.A.A. title and set up a new British record of 147 ft., while Askildt brought the Norwegian record up to 152 ft. 4½ ins.

Then came the ninth Olympiad at Amsterdam. Great Britain, unwisely, I think, made no discus entries, although Howard Ford, C.U.A.C., had beaten 130 ft. on tour in Hungary, and both C. P. Best, C.U.A.C., M. C. Nokes, O.U.A.C., and K. Pridie, Bristol University (No. 1, Plate 46), were showing form with the discus which was at least as good as that displayed by, say, the British steeplechasers and some of the other runners we took over. I think this policy of unduly favouring track men is unwise, since it depreciates the value of field events in the eyes of all athletes, and certainly does not inspire a man to that long and painstaking practice which alone insures success.

On national Olympic trials form in the various countries, we were entitled to expect something sensational, and we certainly got it. Hoffmeister, Händschen, and Paulus, like all the other Germans at Amsterdam, seemed unable to live up to the greatness of the occasion, and Marvalits, Egri, and Askildt all lost their form. The Americans, and some others however, were at their best and beyond it. Clarence Houser won with a new Olympic record of 155 ft. 2½ ins., from A. L. Kivi, Finland, 154 ft. 10½ ins.; J. Corson, U.S.A., 154 ft. 6½ ins.; and H. Stenerud, Norway, 150 ft. 3⅞ ins., the first three beating the previous Olympic best by more than 3 ft.

The evenness of the throwing of the Americans and Scandinavians must, however, raise some moot points upon the question of style, for this sport, like javelin throwing, has developed along different lines in America and Europe, the European, or perhaps one should say more justly the Scandinavian, style producing the more finished performance, and that of the Americans, apparently, the more forceful delivery.

In the European style the rising and falling wave action of the arms is the important feature. For this reason the three sketches of a Finnish discus thrower (Fig. 35) passing from the preparatory stance, by means of a turn, to the throwing position, have been drawn with the path followed by the hand controlling

the discus during the preliminary swing, turn, and commencement of throw indicated by dotted lines and arrow-heads. The

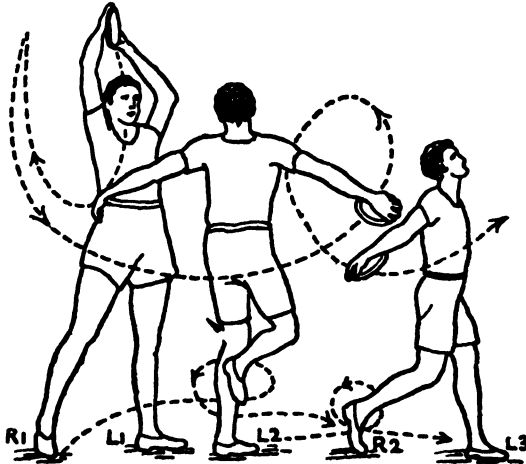

FIG. 35

passage of either foot around the other during the half spin, first on the left and then on the right foot, is similarly shown,

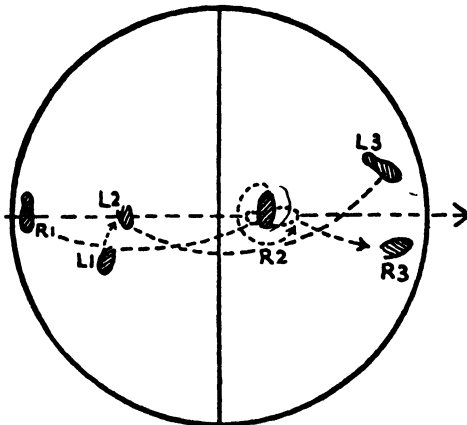

FIG. 36

and further made clear in the corresponding footwork diagram (Fig. 36). The dotted line drawn across the circle in

Athletics of To-day

Fig. 36 indicates the direction in which the discus is to be thrown. To commence the throw the athlete takes up his position at the rear of the circle, with his feet planted at R₁ and L₁, with the discus maintained under the hand by the under-curved finger-tips, as shown in the picture of K. Marvalitz (No. 2, Plate 46). Note particularly the natural relaxed attitude of the arm, wrist, hand, and fingers, and the way in which the thumb is spread out, so that its tip comes level with the edge of the discus. Throughout the whole throwing evolution the discus is kept in position through the maintenance of sufficient centrifugal force, combined with the resistance against its rim of the outermost joints of the fingers.

As soon as the feet are comfortably disposed about 18 inches apart, the athlete lets his weight go forward on to the left foot as he carries the discus with a forward and upward right arm swing to a position immediately above his head and meets it with his left hand, as shown in Picture No. 1, Plate 47. Care should be taken that the back is not hollowed nor the head allowed to go back. G. M. Moll, Bedfordshire County Junior Champion and record holder, shows a correct, well-balanced position in the picture. The way in which the tips of the fingers of the throwing hand overlap the rim of the missile may also be seen. To complete the preliminary swing the left hand imparts a little power to the right, which falls, by its own weight and that of the discus, downwards and is swung up as high as possible above and behind the right shoulder, as shown in Fig. 37, page 289. These preliminary swings may be repeated "till ready." It should be noted that when the discus swings *forward* and up, the body is turned to the left, the weight is on the left foot, and the right heel is raised from the ground. When the discus swings *backwards* and up, the weight goes on to the right foot, the body is turned to the right and the left heel is raised.

In the last swing before the turn begins, and as the discus goes up behind, the left foot is shifted back from L₁ to L₂ on the line of direction (Fig. 36) and the athlete leans forward from the waist (see Fig. 38, page 290). Note that the discus is held



PL. 45]

Sport und Games. [I' 288

THROWING THE DISCUS: GREEK STYLE.

1. Myron's Discobolus, on which was founded the modern Greek style of throwing. 2. D. Gillis, Canada, beginning of turn (Free Style). Viewed from right front he appears in the attitude of Myron's statue. 3. M. Sheridan, U.S.A., Olympic and World's Record holder, showing the starting position. 4. M. Sheridan, U.S.A., about to make the throw.

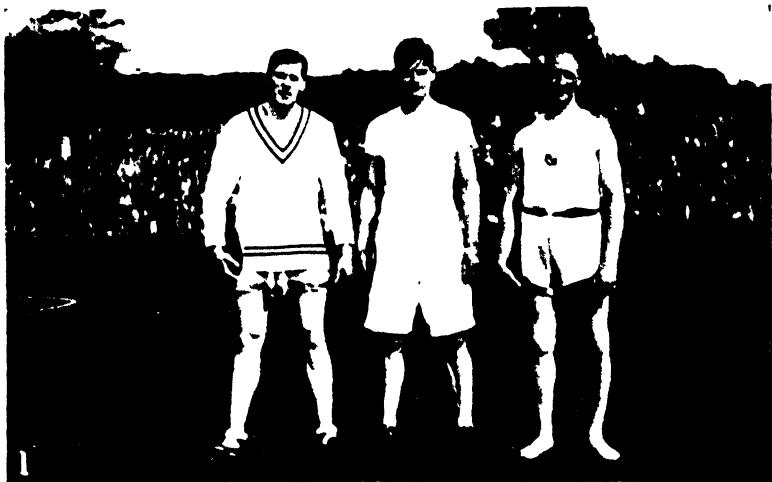

PL. 46]

DISCUS CHAMPIONS.

[U 289

1. M. C. Nokes, O.U.A.C., English Native Record holder, K. H. Pridie, Bristol University, I.V.A.B. Record holder, and F. A. M. Webster, L.A.C., former Midland Counties Champion and Beds County Record holder.
2. K. Marvalts, Hungary, former English Champion and British Record holder.
3. W. E. B. Henderson, O.U.A.C., British Native Record holder.

touching the forearm, there is a good line through arms and shoulders, body is turned well to right to get length of swing, and left heel is raised so that the first half spin, which brings the right foot from R1 to R2 (Fig. 36) may be made on the ball of the foot. This initial spin on the left foot is shown in Picture No. 2, Plate 47, of A. E. Flaxman, so often runner-up in the English Championships. *This first spin on the left foot must be made fairly slowly.* Do not forget this, for it is a most important point to remember. Take care to keep the throwing arm well behind the body and hang it loosely out from the shoulder. That is to say, the body must turn ahead of the discus. The right foot is next put down with considerable force at R2, facing in the opposite direction to that from which it started at R1. Care must be taken to control the left foot spin, and one's balance, so that the right foot falls directly on the line of direction and a little beyond the centre of the circle. At first the novice will find his foot coming down well beyond the line and to the left of it. This, subsequently, will drag back his left foot and give him a bad throwing position. As the right foot comes down at R2 the weight of the body goes forward over the bent right knee and the spinning speed is instantly increased to its maximum velocity. Picture No. 3, Plate 47, shows C. Houser, U.S.A., Olympic record holder, commencing the right foot spin; he is coming towards the camera and not, as might be supposed, travelling away from it. Note the arm balance, body poise, and left foot lift. At R2 the right foot makes a three-quarter turn, rotating on its own axis until it reaches the dotted position in Fig. 36, and is pointing straight along the line of direction. In Picture No. 4, Plate 47, Flaxman is about to complete the spin on the right foot. Note the balance position of the left arm and the drawing back of the right, preparatory to a strong twist of the shoulders from right to left to start the throw, also the bending of both knees preparatory to a forceful leg drive.



FIG. 37

Next, the left foot is put down with much vigour at L3, to

introduce into the throw the check which generates the "jerk," dealt with fully in Chapter XIX (Throwing the Javelin), and the athlete has the throwing position, as shown in Picture No. 5, Plate 48, of H. Hoffmeister, the great German master thrower. Note the walk position of the legs with knees not yet straightened in the drive, the long loose hang of the throwing arm, with discus so well controlled that one surface still rests against the forearm. If the discus is allowed to lose this position it will wobble badly in flight. Note also how the head

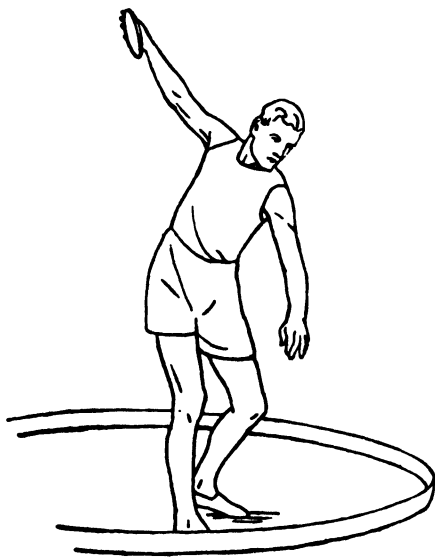

FIG. 38

is being bent back to aid the shoulder twist and right arm throwing-swing around the body, and the compensatory balance position of the left hand and forearm.

The right leg now pushes the body, and particularly the right hip, forward, as seen in Picture No. 6, Plate 48, of Flaxman, in which also the shoulders are being twisted violently from right to left, although the arm does not begin to strike until it is well off the shoulder and both

shoulders and hips are square with the direction in which the discus is to be thrown. In Picture No. 7, Plate 48, the athlete is applying all his force to the throw, by stretching his legs and forcing his right shoulder forward, while the slight blurring of the discus in the photograph shows that the right arm has commenced to make its contribution to the throw and is moving forward on its own swing at the necessary speed to provide a good "jerk," which will give the discus its initial velocity in flight.



Pl. 47]

Sport and General. [U 290

THROWING THE DISCUS: FREE STYLE.

1. G. M. Moll, Bedford School, County Junior Record holder. Preliminary swing. 2. A. E. Flaxman, L.A.C., Northern Counties Record holder, commencing left foot turn. 3. C. Houser, U.S.A., World's and Olympic Record holder, commencing right foot turn. 4. A. E. Flaxman, middle stage of right foot turn.

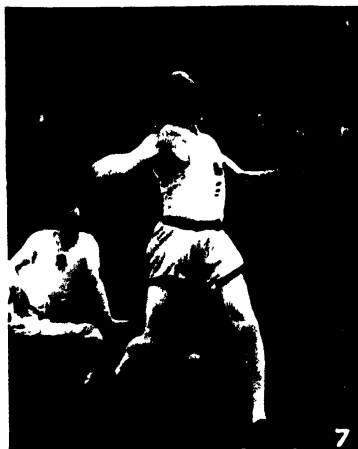

PL. 48]

D S I. and C. I. Lopdell [U 291

THROWING THE DISCUS: FREE STYLE.

5. H. Hoffmeister, German Record holder, set for the throw. 6. A. E. Flaxman, showing shoulder twist and right leg forcing the body forward. Note walk-like position of the legs. 7. F. A. M. Webster, showing the actual throwing contribution of the arm just beginning. 8. G. M. Moll, showing delivery with full leg drive and follow through.

The actual delivery with everything at full stretch and the left leg and side well stiffened, right shoulder pressed up to support the throw, and wrist turned in a final flick, is admirably shown by G. M. Moll in Picture No. 8, Plate 48. The angle of elevation and the tilt to the right at which the discus commences the flight must both be noted. Much the same sequence of action is to be noted in Pictures Nos. 9, 10 and 11, Plate 49, of K. Marvalits, Ketil Askildt and O. Zallhagen. The complete straightness of both legs and full follow through of the right hand is well demonstrated in Picture No. 12, Plate 49, while G. M. Moll in No. 1, Plate 50, shows the beginning of the break-up action in which the left arm and leg swing backwards, and the right foot is shifted with a quick hop to R3 (Fig. 36).

There are two arm waves in the throwing action, whereby the circle is crossed from back to front. The high point of the first wave is just when the turn on the left foot begins, and the low point is reached as the right foot is about to be put down across the direction line. As the right foot spin begins the right hand rises again to a high point, thus commencing the second up and down wave, and the second low point is reached as the left foot is put down at L3 (see Picture No. 5, Plate 48, of Hoffmeister).

W. E. B. Henderson, who has spent considerable time in studying the true science of discus throwing, does not favour the wave arm action, which must be executed with a maximum amount of accuracy if it is to be effective. All his throwing, in fact, was done on a rising, almost horizontal, plane theory. The preliminary swings made from right hip to left shoulder level across the body were followed by what may be described as a rising corkscrew turn. The action started, as shown in Picture No. 2, Plate 50, from a low crouch, and during a spin at increasing speed the legs were fully extended until they came quite straight with considerable snap in the final drive, which accompanied the swinging round of the arm in the throwing action. Many Americans use a similar form which does not, however, give the deep-breathing body stretch in the preliminary swings. The American style swings are made slowly across the body with the back of the hand uppermost, the trunk

being twisted on the hips in time with the backwards and forwards arm swing.

In the other American style, also much in favour with one school of French discus throwers, the discus is supported *on* the palm of the hand, while it is in front of the body, and is then swung with a turn of the wrist to the rear and a bending of the elbow to a position behind the back, as shown in Picture No. 3, Plate 50; this necessitates a much more forward body lean than is required in the other styles. The advocates of this form point out, with a good deal of truth, that it allows of a much faster first pivotal movement being made and that the arm too gains speed by flying out from the body, just as the

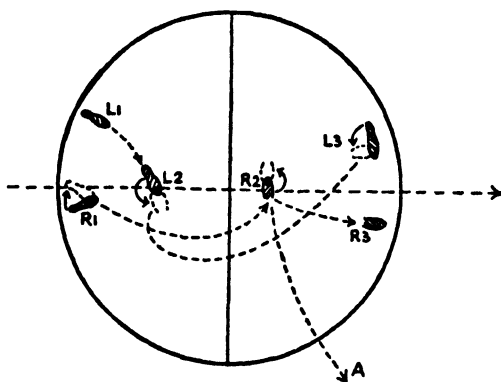

FIG. 39

governors of an engine rise and describe a wider circle as the engine gets up speed. To my mind, however, these advantages do not compensate for a cramped position and a first half-spin started so fast on the left foot that it leaves no cumulative force to go into the second three-quarter spin on the right foot, during which the athlete, as often as not, loses all control.

Another point of dissimilarity between the European and American forms is that the latter usually commence the cross-circle action with a step forward, as shown in the diagram in Fig. 39, from a foot placement in which the athlete faces the throwing direction during the preliminary swings. The

difference in footwork shown in Fig. 36 (European style), and in Fig. 39 (American style) should be carefully studied.

There are three types of finish to the American form :

(1) The European style is adhered to and the reverse of the feet not made until after the discus has left the hand.

(2) The spin on the left foot at L₂ (Fig. 39) terminates in a jump-round which lands both feet simultaneously at R₂ and L₃, with knees bent and body well drawn back to the right. (See Nos. 1 and 2, Plate 52, and the actual throwing stance is seen in No. 4, Plate 50.) The thrower then drives hard up from both feet as the shoulders are twisted from right to left, and the feet are reversed *with* the throw, so that the right foot lands quickly at R₃.

(3) The throw is made with both feet firmly planted, but ends with a pivot on the ball of the left foot (instead of the standard reverse) ; this final spin causes the right leg to swing free to point A, Fig. 39, outside the circle, but without, of course, allowing the foot to touch the ground. This type of finish action is shown in Fig. 40.



FIG. 40

It is claimed for the third style that this finish allows a full follow through of the whole right side of the body ; but, in my opinion, the spin on the left foot does not introduce the stiff leg check to provide the necessary "jerk." It seems to me that the Scandinavians are right in their contention that the left leg and side must be stiffened to resist the tendency of the body to sway to the left.

Much pleasure may always be derived from the practice of the throwing events ; since, to the really keen exponent of these arts, who treats them as such, the result of a contest in actual placing matters hardly at all. I know, for instance, that it gave

me a great deal more satisfaction when, at forty-two years of age, I beat 150 ft. for fourth place in a country javelin throwing contest than I experienced in winning the first English Championship of 1911 at 118 ft. and some odd inches seventeen years earlier, simply because I had learned so much more about the event in the years between and felt that the better performance was due solely to a more finished technique.

To get this kind of pleasure out of one's sport, however, one must make a close study of the mechanics of throwing. The discus thrower, for example, should understand that from the time the discus leaves his hand until it reaches earth there are, from the mechanical viewpoint, merely two main movements which affect its flight. These are an even balance in the missile

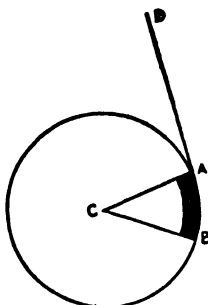

FIG. 41

itself, and a perfect parabola of flight. Imagine the discus as an ordinary fly-wheel, such as one may see attached to an engine, uniform in shape and weight and having a true centre, round which centre the discus revolves at the greatest speed which can be generated by the final spin imparted by the index finger. The diagram in Fig. 41 represents a discus with centre, C, and ABC a segment of it, while the black portion, AB, represents the outer portion of the segment which rotates around the centre.

Any body moving round a centre in a circular path has a tendency to leave that path along the tangent AD, but there is a binding force which reacts to hold the body to its centre. The pull, seeking to drag the defecting segment AB away from its centre, C, and against the binding power working along the lines AC, BC, is called centrifugal force. To stabilize matters and thus obtain a perfect flight the discus must be thrown in such a manner that the centre of gravity will coincide with the centre of rotation.

The same considerations do not obtain in the case of throwing the cricket ball or putting the shot. Both missiles are spherical in shape and thus have all points in the circumference equi-



PL. 49] THROWING THE DISCUS: FREE STYLE. [U 294
TYPES OF FINISH.

9. K. Marvalits, Hungary, showing perfect finish. 10. K. Askildt, Norwegian Record holder. Note continuation of right foot spin completed in leg drive. 11. O. Zallhagen, Swedish Record holder. 12. F. A. M. Webster, complete follow through arm action. Note squareness of hips and walk attitude of legs.



PL. 50]

C. I. Lopdell and Sport and General. [U 295

THROWING THE DISCUS.

1. G. M. Moll, showing left arm back swing. 2. W. E. B. Henderson, showing flat swing and knee crouch, preceding corkscrew turn. 3. T. Lieb, U.S.A., American style starting position. 4. C. P. Hoffman, U.S.A., showing the American simultaneous double foot landing for the throw.

distant from the centre of gravity. Consequently these missiles must always travel with an even centre and with no force reacting through their shape to make them eccentric in flight. The discus, on the contrary, is so shaped that it has every tendency towards eccentricity, and it must be thrown truly and made to spin fast if it is to travel gyroscopically flat ; and, of course, the more body extension force and arm swing, polished off with wrist-flick and finger-pull, that is put into the throw, the faster will the discus rotate. A strong throw without wrist-flick and finger-pull will not enable the discus to revolve fast enough round its centre of gravity, and consequently it will change its rate of rotation, and so wobble in flight, until its horizontal rotation fades right out and the discus rotates vertically.

The following diagram (Fig. 42) shows three positions of a poorly thrown discus, with its centres of rotation along the line AB and not corresponding with the centre of gravity, which passes through the centre screw whereby the discus is fastened together. The constant changing of the centre of rotation and its non-coincidence with the centre of gravity make the discus unstable in flight, and an undue amount of air resistance is created, whereas a discus correctly delivered at an angle of 30 degrees and given plenty of spin will cut through the air edge on and slightly up-tilted, so that the air is forced to bear a good deal of the weight of the missile. The thumb should be used to correct the angle of delivery, for if this be too high the discus will fly face on to the wind and lose distance.

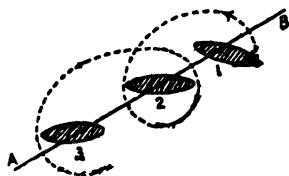

FIG. 42

Points to note are :

(1) The turn is smooth, like a waltz step, and must not be a jump round.

(2) Let the arms hang out loosely when turning and keep the throwing arm back until it is ready to strike when the right shoulder is well forward.

(3) Keep the discus well under the hand with the upper surface against the forearm, as in Picture No. 5, Plate 48 of Hoffmeister.

(4) Maintain a direct line from the left shoulder to the right hand until the discus is in advance of the right shoulder and then complete the throw by hooking the arm right across so that the hand, with wrist also hooked, finishes up at the front of the left shoulder. (See Plates 48 and 49.)

(5) Let the fingers give the discus its gyroscopic spin in rotation. As the throwing arm carries the discus in front of the right shoulder the little finger starts the spin, the other fingers carry it on, but the final spin and direction of flight must be supplied by the index finger alone. In the instant of release try to turn the hand, palm upwards, so that the extreme tips of the fingers may be drawn across the underside of the discus as it leaves the hand. This little trick helps to keep the discus flying through the air edge on and tilted slightly to the right, instead of presenting a flat face to the atmospheric resistance.

(6) The discus is given a lower trajectory than any other missile. The correct angle of departure into the air is one of 30 degrees.

(7) The discus should mount into the air slightly inclined to the right; at the top of its trajectory it should be flying gyroscopically flat, and, as it begins to descend earthwards, should tilt over to the left a little. The angle of ascent is well shown in Pictures No. 8, Plate 48, and No. 9, Plate 49.

(8) Try to keep the hand and discus as far out to the right as possible in delivering the throw; it should be slung round the body from hip level. Do not allow the discus to get close to the thigh.

(9) If the wind is behind you give the discus greater elevation by dropping the arm a little as the throw is started. If the wind is against you, throw lower, by bending the knees a little more.

(10) Follow the discus out with the right hand and shoulder, keep the left shoulder as high as the right and the eyes directed on the discus in flight.

(11) Hold the cross-leg position as long as possible, but let the right foot move quickly forward and the left foot swing up from behind when the reverse is made.

Greater spin may be given to the discus if the thumb and forefinger are closed with a squeezing movement as the discus leaves the hand.

England has not yet produced a really great discus thrower but will do so shortly. The event was added to the Public Schools Championship programme in 1929, and meanwhile such counties as Bedfordshire have held Junior Championships, the boys throwing with a youth's discus, weighing 3 lb. 4½ ozs. The taking up of this sport in the schools will have a marked effect in the near future, for this event must be mastered early in life. What can be accomplished with proper early coaching is proved by the performances of G. M. Moll, Bedford School. I had him first in 1924 when he was twelve, and that year he threw the light discus 67 ft. 4 ins. At sixteen years of age his records were—Light Discus, 124 ft. 4½ ins. ; Javelin, 131 ft. ; Long Jump, 17 ft. 4 ins. ; High Jump, 5 ft. 5¼ ins. ; and 120 yards (3 ft.) Hurdles, 17 secs. He has since thrown the light discus 142 ft., and the full-sized, 4½ lb. missile over 100 ft.

The nude studies of a famous English athlete in Plate 51 and those of him in white in Plate 52 must be carefully studied. In Plate 51 note the working of the inter-costal muscles between the ribs and of the muscles at the junction of the arms and body.

No. 1, Plate 51, shows the commencement of the left foot turn. Note guidance of head, left arm balance, and loose hang of right arm. No. 2 shows the continuation of the left foot turn and further pronounces the head and left arm control, but the balance should have been kept more over the left leg. In No. 3, the right foot spin has commenced at increased speed. Note how the greater rate of rotation has raised the height of the loose arm swing and that the body is moving well ahead of the discus. In No. 4, the right foot spin is nearing completion with the right arm still hanging out loosely and well behind the body. In the next action the athlete will reach the essential preliminary throwing position shown in No. 3, Plate 52.

CHAPTER XXI

THROWING THE HAMMER

HAMMER throwing, like the other three throwing events, is of an antiquity almost as great as that of running and jumping, but the hammer is of even more purely British origin than weight putting, for it was practised under the style of *roth cleas*, or the wheel feat, at the institution of the Tailtin Games of Ireland in 1829 B.C. ; Cuchulain, the mythical Irish Hercules, was the first champion, according to *The Book of Leinster*, and in 1928, 3757 years later, his countryman, Dr. Pat O'Callaghan, for the first time in modern Olympic history, deprived America of the Olympic hammer throwing title. Perhaps it is fortunate for the present generation that legend does not relate what mark Cuchulain made nearly 4,000 years ago.

The next noble figure to flash across one's mind in the recollection of great hammer throwers is, of course, King Henry VIII, who was, by all accounts, extraordinarily efficient at flinging the stiff-handled blacksmith's sledgehammer. There was also Achmat, the last Emperor of Turkey, mentioned in Peachem's *Compleat Gentleman* published in 1622. He made one throw so mighty that two great pillars of marble were set up in Stamboul, presumably to mark the spot from which he threw and the place where the hammer landed.

Coming to modern times, we find that there were no throwing events included in the first Oxford and Cambridge Sports programme of 1864, but a year later the shot put and throwing the cricket ball were instituted. E. A. Gray, C.U.A.C., won the latter event at 103 yards 2 ft. 3 ins., but in 1866 it was abandoned in favour of a hammer throwing event, won by G. R. Thornton, C.U.A.C., at 87 ft. 7 ins. The first man ever



2



4

PL. 51]

THROWING THE DISCUS.

[U 298

1. Commencement of turn on left foot. Note guidance of head, balance of left arm and loose right arm hang. 2. Left foot turn continued. Note head and left arm control and play of inter-costal muscles. 3. Speed immediately increasing on right foot spin. Note body is moving well ahead of the discus. 4. Completing the right foot spin, with left foot swinging round to secure the throwing stance. The right arm is properly hanging out loosely well behind the body.



3

PL. 52]

THROWING THE DISCUS.

[U 299

1. Shows the American style of "jump" turn to throwing position. 2 Demonstrates the landing from the jump turn for the throw. 3. C. Silfverstrand, the great field events coach, demonstrating commencement of delivery position. 4. Faults often seen. The body has gone beyond the throwing perpendicular; the throw is breaking to the right; the right foot has left the ground too soon.

to reach treble figures was Henry Leeke, the elder, who in 1869 won the event for Cambridge at 103 ft. 11 ins., W. A. Burgess, O.U.A.C., a few days later taking the English title at 102 ft. 3 ins. From 1868 to 1872 Leeke and Burgess were English Champions in alternate years, Leeke raising the record to 111 ft. 7 ins. with his last win, while in 1873 S. S. (" Hammer ") Brown, O.U.A.C., so called to distinguish him from numerous other athletic Browns, won against Cambridge at 122 ft. 6 ins., and, although he took the English title in the next year, again beating 120 ft., a new star had arisen at Cambridge in G. H. Hales, who threw 126 ft. 9 ins., against Oxford. In 1875, Burgess became English Champion for the fourth time at 103 ft. 9 ins., but Hales further raised the Inter-University record to 127 ft.

Up to that year nothing, except the weight of the hammer, *i.e.*, 16 lb., had been standardized. A man might have as long a handle as he fancied, run as far as he felt inclined, and throw from any spot that suited him. Two judges were needed—one to mark the position of the thrower's foot when he let the hammer fly, and the other to mark where the hammer fell. These points having been determined, the throw was measured in a straight line from the toe of the thrower's foot to the point of impact. In 1875 the total length of the hammer was cut down to 3 ft. 6 ins. and the throwing space was limited to a 7 ft. circle, without follow. The Universities, however, did not accept these rules until 1881 and the effect upon Hales's form was very pronounced. In the restricted style he won two English Championships, 1876, 96 ft. 3 ins., and 1877, 110 ft., but in the same years and unhampered by rules except as to the weight of the missile, he reached 138 ft. 3 ins. and 138 ft. in the Oxford and Cambridge Sports.

Hales, I have heard, stood nearly 6½ ft. in height, and gave more attention to hammer throwing than any other man, until the late A. E. Flaxman (Plate 53, *et seq.*) made his appearance early in the present century. Hales used a leaden-headed hammer with a long handle to match his great stature and, unlike his contemporaries, could get direction into the throw

after half a dozen very fast turns. Incidentally the judges must have been in constant peril of their lives in those days, for a man might run or rotate as far or as fast as he pleased, and no one, least of all the thrower himself, could tell the direction in which he was going to let drive.

In the year 1881 when the Universities first accepted the Championship rules to govern hammer throwing, W. Lawrence, O.U.A.C., who threw with only one hand, produced the excellent distance of 120 ft. 2 ins. against Cambridge, and that was not eclipsed until the Cambridge "Blue," H. A. Leeke, the younger, threw 126 ft. 8 ins. in 1903.

In 1887 the diameter of the throwing circle was enlarged to 9 ft., and James S. Mitchell, mentioned in Chapter XXII, took his first English title at 110 ft. 4 ins.; in 1896 a shaft of flexible metal was approved of. Up to that time men had got "whip" into the hammer handle by using a shaft of malacca cane, instead of stiff wood, and the late Dr. W. J. M. Barry, a genial Irish giant, who was also a great shot putter, established a record of 134 ft. 7 ins. in 1892, which still stands unbroken for a wooden-shafted hammer thrown from a 7 ft. circle.

In America the pliant metal shaft had been legalized earlier and James Mitchell in his fourth Championship, 1892, had raised the U.S.A. record to 140 ft. 11 ins., and W. O. Hickok, Yale, had set the Inter-Collegiate record at 135 ft. 7½ ins.

The change to a 9 ft. circle made a marked difference in British records. In the first year under the new rule John Flanagan, Ireland (No. 4, Plate 54), reached 131 ft. 11 ins. He then emigrated to America and another Irishman, T. F. Kiely, was English Champion, with one break only, from 1897 to 1902, recording as his best throw 148 ft. 6½ ins. in 1901. He was also Irish Champion eight times, his best throw measuring 150 ft. 3½ ins. In 1900 Flanagan came over from America and reclaimed his English Championship laurels with the huge throw of 163 ft. 7 ins. This caused tremendous surprise in England, for he did not touch 155 ft. 4½ ins. in the U.S.A. Championships until two years later. Flanagan, born in

Limerick in 1873, was a "broth of a boy," and a big fellow, without being among the giants in stature. He won three Olympic, seven U.S.A., and two English titles, besides numerous Irish and Canadian Championships.

Before he emigrated to America, Flanagan had always thrown with three turns, but in the States he found the 7 ft. circle in vogue—it was reverted to in England in 1908—and so cut down his style to two turns. Even this was quite new to the Americans, who had only abandoned the standing throw without follow in 1886, and in 1900 he won the first Olympic Championship at 167 ft. 4 ins. Then A. D. Plaw journeyed east from California and proved that three turns in a 7 ft. circle were practicable. He improved on Flanagan's record, but the great John, working hard, regained it at 171 ft. and won the 1904 Olympic title at 168 ft. 1 in. He saw clearly, however, that he had reached his limit with only two turns, and so he began to practise with three. For three solid years he trained steadily before he could fully control the throw with three turns, but at last he got the trick of it and raised the world's record to 181 ft.

The 1908 Olympic Games in London brought together an amazing number of brilliant hammer throwers. Two years earlier Matt. McGrath (No. 7, Plate 55) had won the American Junior Championship at 161 ft. 2 ins., only 6 ins. short of S. P. Gillis's record of the year before. In 1908 he beat both Flanagan and Gillis for the A.A.U. senior title at 173 ft., but broke a knee ligament when practising the high jump two months before the Games. He was born in Tipperary, Ireland, in 1878, stood a quarter of an inch under 6 ft. and weighed just under 18 stone when he arrived in London to represent the United States. Con Walsh, representing Canada, was born at Cork in 1882 and had won the Irish Championship at 152 ft. in 1906 and actually represented Ireland against Scotland in the month that the Games were held and so might fairly have been claimed to represent Great Britain. Despite his broken ligament McGrath was expected to win and did in fact lead throughout the contest, until Flanagan got in a lovely heave

of 170 ft. $4\frac{1}{4}$ ins., which beat McGrath's best by nearly $2\frac{1}{2}$ ft. Walsh was third at 159 ft. $1\frac{1}{2}$ ins., and Tom Nicholson, Scotland (No. 3, Plate 54) fourth, 9 ins. ahead of D. L. J. Talbot, U.S.A., at 157 ft. $9\frac{1}{4}$ ins.

Nicholson and Gillis might have done better ; for the latter, who threw 149 ft. $6\frac{1}{2}$ ins. in the stadium for seventh place, had won the English title at 164 ft. $5\frac{3}{8}$ ins., and the former had taken the Scottish title at 162 ft. 8 ins., but neither man could maintain a proper foothold on the sodden, slippery turf.

Nicholson has had a remarkable career, and although now fifty years of age can still touch the 150 ft. mark and that is almost up to Olympic standard. In 1902 he won his first Scottish Hammer Throwing and Shot Putting Championships. Since then he has been selected four times to represent Great Britain at the Olympic Games, his last appearance being at Paris in 1924, although he would have had no difficulty in qualifying for the British team in 1928. He has won twenty-seven hammer throwing, sixteen shot putting, and four 56 lb. weight slinging championships in England and Scotland.

From 1908 onwards McGrath's star was in the ascendant, and at Long Island, U.S.A., on October 29th, 1911, he set the world's record mark at 187 ft. 4 ins. In the following year he raised the Olympic record to 179 ft. $7\frac{9}{8}$ ins., winning from Duncan Gillis, Canada, 158 ft. $9\frac{1}{2}$ ins., but Tom Nicholson did not compete. That year the Scandinavians made their presence felt for the first time, C. Lind, Sweden, placing fourth at 149 ft. $7\frac{1}{2}$ ins., and other Swedes coming sixth and eighth thanks to the coaching of Ernie Hjertberg, who had come home from America to instruct his fellow countrymen. In the following year Lind came to England and was the first foreigner.

perseverance in hammer throwing, combined with close attention to physical culture, he achieved the incredible distance, for so light a man, of over 150 ft., using four turns in the 7 ft. circle. Given the weight of Flanagan, Nicholson, or McGrath, there is little doubt that he would have beaten 200 ft. for, as it was, he threw more than a foot in distance for every pound of his own light weight. Flaxman had two ruling passions—both governed by and calling for an extraordinary sense of rhythm—one was music and the other the types of sport requiring all the qualities of hardy manhood. This is a far less unusual combination of tastes with the heavy-weight field events men than might be imagined. He was an excellent violinist and no mean artist with pen and brush.

At the Olympic Games, in 1908, Flaxman represented Great Britain in the standing high jump, discus free style, discus Greek style, and javelin free style. A year or so later he was Sandow's show pupil in feats of strength and made light of such tricks as tearing a couple of packs of cards in half. He was showing considerable promise as a boxer and gymnast and had added the pole vault—in which he was English Champion in 1909—and shot putting to his other athletic events, but it was as a hammer thrower that he was beginning to make his mark. Day by day he would go down to Stamford Bridge from Baker Street, and there train steadily until lunch time. A pint of stout and a pound of steak furnished his midday meal, and then back he would go again to training, studying out every step in technique and adding new points to his style as he went along.

From under 120 ft. he worked up to over 150 ft. with the hammer, and many were the amusing incidents of those pre-War days. On one occasion, when Flaxman was throwing, there was an obstacle race in progress at the same time. One obstacle was a sort of rabbit hutch through which the competitors had to crawl. Just as Flaxman let drive with one of his big throws, a little white-faced rat of a fellow dived into the hutch; as he came out on the other side the hammer crashed through it, completely wrecking the whole structure.

That runner gave one agonized shriek and streaked straight for the pavilion, with no thought of finishing the race. Obstacles of any kind he would have faced cheerfully, but showed a marked aversion from being shot at with 16 lb. cannon balls travelling at 50 to 60 ft. per second.

I think it was in 1913 that Flaxman at Prague, or Buda-Pesth, established the still unbroken Bohemian record, and in 1914 he made the present Northern Counties Championship record of 140 ft. Then came the War, and he joined the battalion of the South Staffordshire Regiment, of which I was adjutant. The men simply adored him, and in the "Bull Ring" at Etaples he amazed every one by his prowess as a bomber. He was with "C" Company in France, and on one occasion when the Bosches blew up a mine close to the Company dug-out, Flaxman's bombing came in mighty handy. One man in the listening post vanished completely, and two others were fast embedded in duck-boards, wire, and chalk. Flaxman and another officer named Magrane dashed to the rescue, the former keeping the far edge of the crater clear with a perfect torrent of bombs, while the latter dug out the unfortunate soldiers, and both were recommended for the M.C.

On another occasion the C.O., going round the front line trenches, found Flaxman seated on the fire step, *sans* boots, puttees, and socks, and apparently ruminating contentedly. It appeared that he had been prospecting up an old sap towards a crater some 80 yards in front of the line. It was pitch dark, and, to make matters worse, there were any number of mining galleries, made and occupied earlier by the French. Flaxman proceeded the deuce of a way before he heard a sound. Then suddenly, at a traverse, he was met by two men and challenged in German. His revolver stuck fast in its holster, but he had in his hand a hefty, loaded trench-stick, which we had bought together in London. With this weapon he laid out both men and bolted for his life. This all sounded pretty good until next day, when the C.O. was called upon to explain what the this and that some one under his command



PL. 55]

THROWING THE HAMMER.

THE SWING (cont.)—5. A. F. Flaxman. The high point in the preliminary swing. 6. A. F. Flaxman. The overhead point position
 THE TURN—7. Matt. McGrath, U.S.A., Olympic Champion. First movement in commencing the turn. 8. T. Nicholson. Beginning of
 first spin on left foot.

Sport and General. [U 304

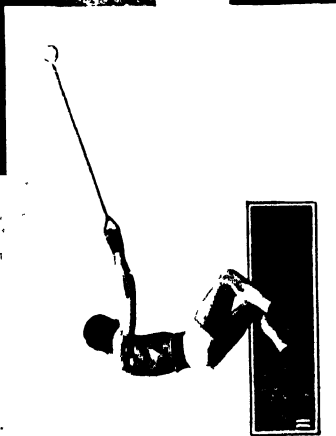
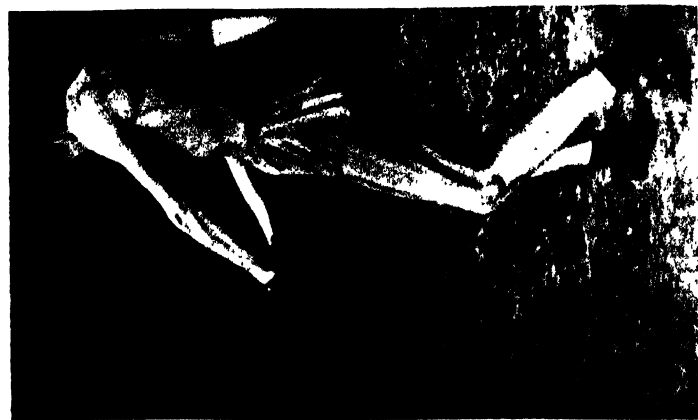

PL. 56]

THE TURN (cont.)—A. E. Flaxman. 9. At the end of each turn the left foot is withdrawn to commence the next. 10. The speed increases with each turn. Spin starts on left heel. 11. The athlete sinks his knee, but rises on his toes. 12. Grounded leg is straightened as the hammer head reaches its high point in the turn. Note the straightness of the arms in all four pictures.

[X 305

meant by brutally assaulting our Alsatian allies, who had remained at their post some days after the rest of the French troops had been withdrawn!

Lieut. G. Howard-Smith, M.C., the famous C.U.A.C. high jumper, who preceded Flaxman as battalion bombing officer, died of wounds on March 29th, 1916, and Flaxman was killed in the attack upon Gommecourt during the first Somme offensive on July 1st, 1916. Thus passed two very gallant sportsmen, who had used their peace-time pursuits to the fullest advantage in the grim game of war.

Flaxman has a worthy successor in the diminutive Scottish international, J. Jackson, of the Field Events Club, Edinburgh, who is of similar height and gifted with a like tenacity. There is a good tale told of his extreme keenness, from which it would appear that, as he was unable to get out to a training ground in the day-time, it was his wont to practise swinging and turning in a deserted street very late at night, until one night he slipped and let the hammer fly clean through a plate glass window. I give the tale as an instance of athletic keenness, but do not vouch for it as being true.

In 1906, the same year that Flaxman first took to spiked shoes, Pat Ryan came into the game. He was born at Pallas-green, Co. Limerick, Ireland, in 1887. At nineteen years of age he stood 6 ft. 2 ins., weighed 12 stone 10 lb. and had already become naturalized in America. It took him eight years to work up to hammer throwing championship standard, and so he did not get into the American team for Stockholm in 1912. The following year, however, he won his first A.A.U. title at 177 ft. 7½ ins. and that title he held right through until 1922, except for 1918 when McGrath again became champion at 173 ft. 11½ ins. Ryan, however, never again found such form as in 1912, for in that year he put the world's record at its present limit of 189 ft. 6½ ins. and, incidentally, had increased in weight to 17 stone 12 lb. This increase in weight is typical of most hammer throwers, for McGrath also put on 3½ stone between 1906 and 1913.

Ryan won the Olympic hammer throw at Antwerp in 1920,

at 173 ft. 5 $\frac{1}{2}$ ins., and C. J. Lindh was second at 158 ft. 10 $\frac{1}{2}$ ins., M. Svensson, also Sweden, being fourth, McGrath fifth, and Tom Nicholson sixth. This Lindh was a great thrower, short in stature and very heavy, but he could only reach his best results when trained under the eagle eye of old Ernie Hjertberg right up to the last minute before competition. In 1921 he carried off the English title at 161 ft. 11 $\frac{1}{4}$ ins., with his third throw of six attempts.

Meanwhile, since 1910, hammer throwing at the Oxford and Cambridge Sports had degenerated into something very like an annual walk-over for some American Rhodes Scholar. Immediately after the War, however, Bishop's Stortford School sent up to Oxford a big youth of extraordinary strength in M. C. Nokes (No. 2, Plate 54). He did not shape exceptionally well at first. In the Olympic Trials, 1920, he had a walk over at 106 ft. 10 ins., and in the A.A.A. Championships was fifth at 101 ft. In 1921 he suddenly found his form, but luck did not come his way. In March he won the Inter-University event at 148 ft., and with an exhibition throw, not reckoned as a record, reached 160 ft. 5 ins., easily beating all previous bests, and at the championships in July he placed second to Lindh with a throw of 155 ft. 11 ins. That was the year that, by the irony of fate, Oxford and Cambridge decided to drop hammer throwing from the Inter-University Sports programme—just as they had found a world's champion, if ever there was one!

Nokes's evil fortune still prevailed. In 1922 Lindh was again English champion with a new British record of 172 ft. 3 $\frac{1}{2}$ ins., Nokes, second, 161 ft. 7 ins., and Ville Pörhölä, the Finnish shot putter, third, at 160 ft. 3 $\frac{1}{2}$ ins. In 1923 Nokes took his first Midland Counties title at 172 ft. 0 $\frac{1}{2}$ in., only 3 $\frac{1}{4}$ ins. short of British record; in July he won his first of four English titles in sequence at 161 ft. 4 $\frac{1}{2}$ ins., and in August at the British Games, organized by *The News of the World*, reached 172 ft. 7 $\frac{1}{2}$ ins., thus beating British record, but the record could not be accepted as he was the only competitor. One morning in the practice ground beside the Olympic stadium at Paris, I "stepped" one of his throws, which I'll swear was over 180 ft.,

and I thought him certain to win, despite the fact that F. D. Tootell had beaten 173 ft. at the U.S.A. Championships and McGrath was back to at least 170 ft. form. Well, with his first throw Nokes touched 180 ft. all right, but came out of the circle before the hammer hit the ground, and I think I am right in saying that he only got one throw out of six measured, that one—160 ft. 4½ ins.—giving him third place to the two Americans, F. D. Tootell, 174 ft. 10 ins., and M. J. McGrath, 166 ft. 9½ ins. Finland and Sweden filled the next two places. The former country has not yet quite caught on to the game, but Sweden may produce a world beater at any time now.

The year 1927 was notable for several reasons. Sweden had developed a fine thrower in O. Sköeld, who was placed fifth at Paris (148 ft. 6½ ins.), while A. Poggioli raised the Italian record to over 160 ft. The Swede came over to England and took the A.A.A. title at 165 ft., beating Nokes by just over 3 ft., a very fine German, J. Mang, finishing third. A couple of weeks later the International Match between England, Ireland, and Scotland took place at Fallowfield, Manchester. Nokes won the hammer at 162 ft. 9½ ins., but Dr. P. O'Callaghan, who competed in football boots and had been at the game less than a year, threw 151 ft. 5½ ins. for second place, and W. Britton, his fellow Irishman, was third at 150 ft. 3 ins.

The Olympic year, 1928, caught Nokes clean off form. He took the Midland Counties title at 146 ft. 6½ ins., throwing in a pair of borrowed shoes, which circumstance, I hoped, might account for the obvious falling off in his form, but in the A.A.A. Championships he was beaten half a foot by the Irishman, W. Britton, who reached 152 ft. 11 ins.

We still hoped against hope that Nokes would stage a great come-back, at last break his bad luck, and achieve Olympic laurels at Amsterdam, for Jack Merchant was America's best man, and he had reached but 170½ ft. in the U.S.A. Championship, while Nokes had proved himself in the past a better thrower than any of the Continentals. I don't think any of us expected that Dr. O'Callaghan, with his short experience, was going to "spill the beans" and spoil America's run of success, which had

Athletics of To-day

remained unbroken since the hammer was instituted as an Olympic competition in 1900. Nokes, in Holland, failed to beat 153 ft. to qualify for the final, which O'Callaghan won at 168 ft. 3 ins. from O. Sköeld 167 ft. 11 ins., and E. Black, U.S.A., 160 ft. 10 ins., with A. Poggioli, Italy, fourth, 158 ft. 7 ins., and Americans fifth and sixth.

America may be said to have maintained a high standard. The full statistics of the 1900 and 1904 Games are not available, but from and including 1908 results in the first six places read as follows :

	1st	2nd	3rd	4th	5th	6th
U.S.A.	4	3	2	0	4	3
Sweden	0	2	0	2	1	1
Great Britain	0	1	0	1	0	1
Canada	0	1	1	0	0	0
Ireland	1	0	0	0	0	0
Finland	0	0	0	1	0	0
Italy	0	0	0	1	0	0

It may be noted that of the sixteen American places, seven were scored by naturalized Irishmen, that of the two Canadian places one was gained by a Scotsman and the other by an Irishman, and, similarly, of Great Britain's three places, two were taken by T. Nicholson, Scotland, and the other by M. C. Nokes, England. Since, moreover, the three biggest throws ever recorded were made by Irishmen naturalized in America, there is strong presumptive evidence that the Irish Celt is peculiarly adapted to this sport, which his forefathers first invented. I believe, indeed, that I am correct in saying that the only man, not of Irish birth, who has ever beaten 180 ft. in competition is F. D. Tootell, Bowdoin College, U.S.A., who took the American Inter-Collegiate title at 181 ft. 6½ ins. in 1923. On the other hand I am equally certain that M. C. Nokes could have thrown as far as any of them, including Pat

Ryan, had he been afforded such expert coaching as is available in America, or even if he had been given an adequate amount of competition. But Nokes has had to work out his own salvation, absolutely unaided by tuition ; and his chances of competition have been almost entirely confined to championship contests.

So far as one can judge, a new generation of hammer throwers is growing up in Ireland, but Scotland is at a standstill, and the sport is going back in America. Italy, and other countries, may produce an odd outstanding thrower, as England has done, in Flaxman and Nokes, but I fancy it is to Sweden, Finland, or possibly Japan, that we must look to produce the next world's record breaker. Sweden has come on very fast, Finland is learning quickly, and no man living dare prophesy about the probable future of Japan, having regard to the amazing athletic progress made in the Far Eastern country since the War.

Hammer throwing more than any other event calls for height, weight, and an exceptionally fine physique, but all these admirable physical attributes will avail a man nothing if he has not the mentality to understand the technique of the event, and that unbounded patience and perseverance which alone will allow him to practise long enough to build up a perfect style.

Flanagan showed these qualities when he devoted three years to gaining steadiness in throwing at the end of three, instead of two, turns. Flaxman mastered the fourth turn with perfect control in delivery, because he devoted as much time in spring and summer to the sport as he spent hours a day in the winter in playing his fiddle, and these qualities of patience and dogged perseverance the Scandinavians and Japanese exhibit to a marked degree.

The following figures will interest those who appreciate the mathematics of athletics, for they go far to prove my contention that hammer throwing is, *ipso facto*, a sport for a big, strong fellow. The late Major R. V. Mostyn, Flaxman and I worked out the calculations in 1914, as a test of how far the theory of dynamics enters into athletics. We took for our purpose Flaxman's throw of 150 ft. made at the end of four turns

within a 7 ft. circle. After due consideration we decided that the weight of the thrower affects the issue only in so far that a light-weight must experience more difficulty in preserving his balance against the colossal pull of the whirling hammer-head than would a man of greater bulk.

The question of the number of turns to be used was debated at great length. One or two turns, obviously, would not yield sufficient acceleration for a big throw, and, of course, the whole success of the effort depends upon the velocity at which the hammer-head is moving at the moment it leaves the circle, on which it is revolving, at a tangent. Plaw, first, and then Flanagan, had proved the practicability of three turns, and now Flaxman had shown that a fourth turn was not impossible of accomplishment, but five turns at an increasing acceleration had been found impracticable within the narrow confines of the 7 ft. ring, mainly because the centrifugal force exerted by swinging a 16 lb. hammer and turning with it at speed is simply enormous, and the check effort, which introduces the jerk, described in Chapter XIX (Throwing the Javelin) is correspondingly great.

In the case of a 16 lb. hammer being thrown to a distance of 150 ft. the centrifugal force exerted, that is to say, the pull upon the athlete's arms, is no less than 366 ft.-lb. and the initial velocity of the hammer as it is released by the hands is 69 ft. per second. To this one may add that if the throw is made at the correct delivery angle of 45 degrees the greatest vertical height obtained in the parabola of flight will be 37 ft. 6 ins. and that the hammer will take just over 3 secs. to reach the ground at a point 150 ft. from the edge of the throwing circle, at which the athlete stands balanced until the hammer has come to earth.

The improvement in the "hammer" itself, and in the method of throwing it, is clearly emphasized by the fact that when R. J. James, C.U.A.C., took the first English title of 1866 at 78 ft. 5 ins., he used what was virtually a blacksmith's sledgehammer and threw it from a standing position without any preliminary turn. Since those days four men at least have

thrown over 100 ft. further and hundreds have doubled his distance, because they had the advantages of a better hammer and a better style. Quite soon the blacksmith's "sledge" gave place to an iron ball fitted to a cane shaft ; other improvements followed, and to-day the athletic hammer is a hammer by courtesy alone. It consists of a 16 lb. brass shell attached by means of a ball-bearing swivel to a shaft of $\frac{1}{8}$ in. spring wire, terminating in one, or two, stirrup handles for the insertion of the thrower's fingers.

As to the evolution of method. Hardly had the sport been taken up seriously than some one envisaged the mechanical principle that the hammer-head was, as it were, attached to the circumference of a circle, and that if the circle had the motive power of a spinning human body at the centre much greater distances would be reached than ever were possible to a man who threw standing still. There is only one actual style of hammer throwing, although there occur slight variations in the footwork according to the number of turns the athlete elects to make use of to work up cumulative speed for his throw.

To begin with, the standing throw and the turning movement, whereby the circle is traversed, should be practised and mastered separately. To make the standing throw, the athlete takes up his position at the *front* edge of the circle, from which point the throw is normally delivered at the end of the turn, back facing the direction in which the throw is to be made, feet about 24 inches apart, heels about 6 inches from the edge of the circle. The first joints of the fingers are looped into the stirrup handles at the end of the piano wire shaft, but if only one stirrup handle is used, then the left hand should be inside against the handle and the fingers of the right should grip over the fingers of the left hand (see Picture No. 2, Plate 54, of M. C. Nokes).

The starting position both for the standing throw and the turn is as seen in Picture No. 1, Plate 54, of A. E. Flaxman. Some athletes, however, prefer to lay the head of the hammer further behind them and to bend the body forward from the

hips so that the hands come level with the right knee, thus gaining a longer starting pull. In either case the object should be to start the swinging movement smoothly. If it is begun with a jerk there is a tendency to cramp the arms at the elbows and to swing the hammer in an up and down circle from ground level to a high point above the head. If the arms are cramped the radius of the circle described by the hammer-head is restricted and speed lost. An up-and-down, nearly vertical, swing necessitates a change of direction in the path of the hammer in the transition from swing to throw.

Picture No. 3, Plate 54, of Tom Nicholson, Scotland, brings out many important points. First, the disposition of the hands when a double stirrup handle is used should be noted. The body is swaying back to resist the pull of the hammer-head, and the arms are stretched out *straight* as far as possible from the shoulders, so that they may elongate the length of the hammer-shaft to the fullest extent, thus giving as great a radius to the swing as can be attained. The low point in swing, it will be observed, is when the hammer-head is in front of the right foot. As the hammer-head comes in front of the centre of the body the arms, still perfectly straight, raise it higher above the ground and the thrower leans further back to resist the more direct pull. All this is seen in Picture No. 2, Plate 54, of M. C. Nokes. Note the hand-hold with a single stirrup handle and also that the knees are very slightly bent.

As the hammer-head passes to the left side of the body and begins to rise the right hand, at the end of a straight arm, is turned palm downwards, the left elbow and right knee are bent, the left leg is stiffened, and the body turned slightly towards the left. Follow out these actions for yourself in Picture No. 4, Plate 54, of John Flanagan.

Plates 55 and 56 contain pictures of Flaxman. When the hands are level with and in front of the point of the left shoulder, the left upper arm is pressed into the body, the right shoulder is raised so that the right forearm and the hammer-shaft come almost parallel to the ground. The hands are lifted well above the head to maintain the biggest radius of swing.

Throwing the Hammer

313

See Pictures Nos. 5 and 6, Plate 55, and note that although the trunk is swaying to the left, the weight is on the left leg and the body from the waist downwards is kept over to the right in counter balance. Note that the back of the right hand is still uppermost. The muscles of the thighs, back, abdomen, and sides are doing the main part of the work here.

From Pictures Nos. 5 and 6, Plate 55, it will appear that the high point in the swing has been reached with the hammer-head in rear of the left shoulder. Flaxman shows a finely powerful pulling position for the downward swing. The "play" of the body muscles is especially interesting. Observe the full reach of the hands behind the head, the flexion of the knees, body sway forward and to the left to resist rear and commencing of right pull of hammer, and that the right forearm has maintained its parallel to the ground position. The right upper arm is pressed into the side an instant later. Note that the hammer has a wider radius on the right side of the body than it has on the left. In these two pictures the use made of the head as a "rudder" to the hammer path should be considered, because the head is really the helm of the body and an athlete who uses it properly—not only to think with—gains a big advantage in the throwing events and the jumps. Note in Picture No. 5, Plate 55, that the chest, head and hips are square to the front, the shoulders alone being twisted to the right, and that the weight of the body is still disposed over the right leg. As the hammer-head is pulled down and out to the right of the body, the weight passes from the right leg to the left, the arms and legs straighten out, and all is at full stretch once more when the hammer-head again reaches its low point in front of the right foot.

The preliminary swings may be repeated as many times as desired, but each should be faster than the preceding one. Three is usually a sufficient number of swings. When the hammer reaches the position shown in Picture No. 5, Plate 55 in the third or last preliminary swing, the athlete gathers himself for the throw, but the actual throw does not commence until the hammer-head is reaching its low point and is off the right

hip. (See sketch of C. J. Lindh in Fig. 43.) It should be noted that the thrower is turned towards the hammer, which is out at the fullest extension of the perfectly straightened arms and shoulders, the body is leaning away from the hammer to resist its pull, and the knees are flexed, the left one being bent more than the right.

Most of the pulling power is now on the left side, and the weight therefore is on the left foot. The arms must be kept straight ; if bent at the elbows the rhythm of movement will be broken. They must move with the hammer until the last

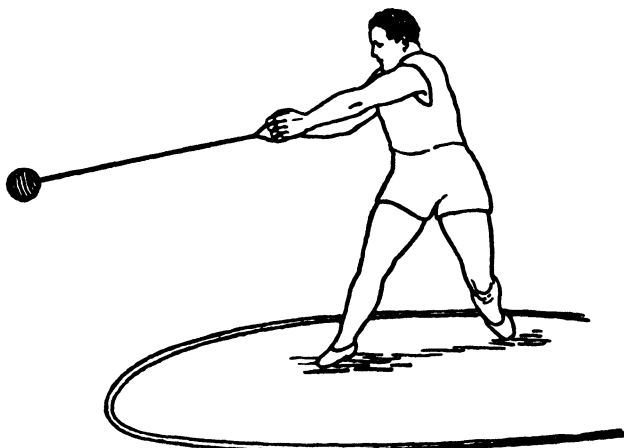

FIG. 43

moment. In the final heave-effort the body must turn ahead of the hammer with thrust from the right foot and full resistance from the left leg and side. As the arms execute the throw, out over the left shoulder, they are lifted as high as possible and the legs are fully straightened, so that the power travels right up from the toes, through the body and is transmitted to the hammer through the fingers. This combination of movements should leave the thrower with legs crossed at the knees, body at extreme stretch, and arms completing the full follow through, as shown in Fig. 45, page 317. This balance is retained as long as possible ; when the position can be held no longer the

thrower releases the pressure on the left foot and quickly reverses both feet so that he faces the flight of the hammer and stops himself from fouling, through coming out of the circle after the hammer, as shewn in Picture No. 16, Plate 57.

The importance of giving the hammer head the biggest possible radius in preliminary swings and keeping it out at full arm and shoulder stretch during the turns may be appreciated if the reader will consider the formula for finding the circumference of a circle, which is $2\pi r$, π being 3.1416 and r being radius. Velocity and a large path for the hammer-head are the desired factors. If it takes six seconds to describe a 40 ft. circumference, then obviously, if the radius be increased and a circumference of 45 ft. is described in the same space of time, it follows that the hammer-head must acquire an increased velocity and that the whole implement will therefore fly through a greater distance when it is released from the hands.

During the preliminary swings it is the arms and not the body that increase the speed. The turning movement commences on the left foot as the hammer descends on the right side, at the end of the last of the preliminary swings, and when it is off the right hip. An instant before the turn begins the right knee is inclined inwards to the knee of the left leg, then the body is twisted to the left, *moving ahead of the hammer*, and the turn is commenced on the heel of the left foot. Take care to keep the left arm fully extended across the body, as shown in Picture No. 7, Plate 55, of Matt McGrath, and lean the body towards and over the left leg, which must support the whole weight. The right foot follows close behind with a full circle, and begins early to get the pivotal movement over on to the outer edge of the left foot. A few good throwers prefer a spin on the toes, as Tom Nicholson is seen doing in Picture No. 8, Plate 55, and thus the sooner gain a double straight-arm position, but there is a slight danger here of the hammer travelling ahead of the body, when it will take control and drag the athlete round, so that he will have neither form nor length of pull for his final heave.

The left foot does not leave the ground until the right foot is down at R₂ (see diagram, Fig. 44). It is then quickly withdrawn to L₂ as shown in Picture No. 9, Plate 56, of A. E. Flaxman, and No. 14, Plate 57, M. C. Nokes. Note that the hammer should be at its low point in front of the right foot when the left foot is drawn back, preparatory to the commencement of the next turning movement.

With the left heel well grounded, body leaning back from the hips, arms straight out and knees bent, the thrower picks up the right foot to carry it round the left leg in the second (or third) turn. (See Picture No. 10, Plate 56, of Flaxman.) In the next three pictures the same athlete shows how the turn continues.

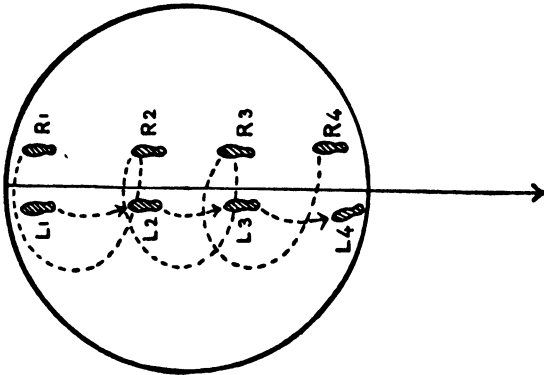

FIG. 44

No. 11 shows the central point where he comes up on to the toes of the left foot, bends the left knee still more, and allows his trunk to come up to an almost vertical position, with shoulders forward and lower girdle of the trunk resisting the hammer pull. Note the forward lifting of the right foot. No. 12 depicts the high point in the path of the hammer during the turning movement, which coincides with a full extension of the left leg, further backward body lean and the complete pick-up of the right foot to left knee level; and No. 13, Plate 57, the body lean to left, pivot taking place on outer side of left foot, and the commencement of the whipping of the right leg around left from its highest foot position. In No. 14 Nokes is seen making the

second shift back of the left foot prior to the third turn. In No. 15, he is withdrawing his left foot at the end of the third turn to gain the throwing stance shown in Fig. 43, page 314.

The actual throw commences from the final stance, shown in Fig. 43. The final heave is an upward one and is largely governed by the straightness of the arms during the last turn. As the hammer is on its way up, the legs, body, and arms must be straightened with all possible speed and force, while the left foot presses hard against the ground to maintain a strong point of resistance. Let

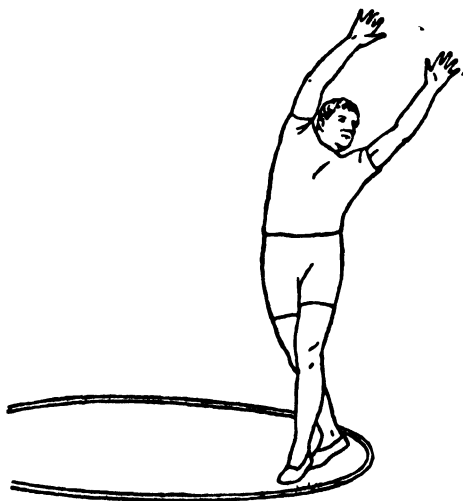

FIG. 45

the arms move with the hammer right through the throw, and turn the body with the throw in the final release, but do not shift the feet. This gives the follow through finish-up shown in Fig. 45.

The way the reverse is made, and the thrower turns to face the direction of the throw is shown in Picture No. 16, Plate 57, of Flaxman, finally turned from a back-to-hammer-flight to a front-to-

hammer-flight position. Above almost everything else learn to keep the body moving ahead of the hammer all the time and let the speed in swinging, turning, and throwing be an ever-increasing effort culminating in the final delivery. This body-ahead-of-hammer turn is especially well shown in Fig. 46.

Some hammer throwers do not favour the "one foot always on the ground" turning style as described above, but prefer a

series of jump spins, in which both feet are off the ground as the turn is made, but it is the pull of the hammer that carries this type across the circle. The style does, however, make for maximum spinning speed.



FIG. 46

The main reason there are so few first-class hammer throwers in the world to-day is because there are but few athletes who have the patience to face the difficulties and the often tedious practice inseparable from the building up of a perfect style. The main trouble is to acquire steadiness in swinging and turning, but once stability is found it is amazing how rapidly one progresses towards really satisfactory achievements.

TRAINING

The training for hammer throwing differs a good deal from the preparation for other events, since the one royal high-road to success is to throw and to keep on throwing. But the exercise is severe, and the strain, due to the weight of the implement and the "pull" it imposes upon the thrower, is great. A start should be made, therefore, with a 12 lb. hammer, which will allow the athlete to throw in good style and at the proper elevation with each delivery. Gloves should be worn to prevent the fingers becoming lacerated by the comparative thinness of the stirrup handles; and, at all times when the weather is at all cold, a sweater and track trousers, such as those worn by Nurmi in Picture No. 1, Plate II, should be worn to protect the body and limbs. This is particularly important to hammer throwers, since a big strain placed on a cold muscle is almost bound to lead to a rupture.

Work with the hammer will itself develop the upper body, as no other series of exercises could do, but the legs must be looked after, and to this end there should be a certain amount of sprinting for speed and half-mile jogging for endurance. Throw five times a week, starting with three throws for distance

on one day only; on the other days throw for style. Increase to six, and then to ten, and finally to twelve throws for distance on the day of the weekly try out, but take a "complete" rest of three to five minutes between each throw.

On the other training days work for perfection in turning at a speed that increases with each turn. Work for height in hammer flight and perfection of delivery. Above all, work to master the event so that all your evolutions are rapid, but none of them is hurried.

When you are in competition trim, throw from six to a dozen times Monday, and again Tuesday, lightly to correct any faults in style or to improve technique. Wednesday, from six to a dozen throws for distance. Thursday, do your sprinting or jogging. If the weather is bad work in the gymnasium at stretching exercises to keep your muscles supple. Friday, rest. Saturday get a competition if you can. Failing that, stage a trial with another hammer thrower. Go out together and do the thing properly. Limber up, take one or two light throws to stretch yourselves, then have six competition throws, with a three minutes interval between each, and put on your sweater and track trousers while you are waiting for your next turn to throw.

Detailed suggestions for building up the technique are as follows:

Practise the preliminary swings and the standing throw first. When swinging sway the body and shift the weight from foot to foot, the weight being always away from the hammer.

Keep on watching the hammer-head. If your eyes follow it all the time, except, of course, when it is behind the head, you will find that your body conforms quickly and loosely to the rhythm and disposes its weight naturally to resist the pull.

It is of no use to practise the turns without a hammer. Commence the turning practice with a 12 lb. hammer. Begin with one turn and a light throw. Then increase the strength of the throw. When it is time to add the second turn, spin rapidly on the ball of the left foot, stamp the right foot down, and drop the left foot a step backwards in a line with the right foot;

repeat the evolution when the left foot has been withdrawn for the second time. It takes a long time and a lot of patience to get the knack of turning and throwing, but once it is mastered it is like riding a bicycle or swimming ; you never lose it again.

In spinning on the left foot try to transfer the spin from the heel to the ball when the foot has made a half revolution and is pointing in the direction of the throw.

Train always in a 7 ft. circle and have a 90 degree sector marked out on the ground, because the rules require that the hammer shall fall within the limits of such a sector in competition.

Divide the circle with two lines drawn at right angles and bisecting each other at the centre. The rules require the hammer thrower to leave the circle by the back half after making his throw, and the line that divides it in half from front to rear is one of direction for your own convenience, so that you may watch your foot-work and learn to turn in a straight path from rear to front of the circle, the feet landing on either side of the direction line at the conclusion of each turn.



Pl. 57]

Sport and General [X 320

THROWING THE HAMMER

THE TURN (cont)—13. A. E. Flaxman, turning on the outer side of the foot with the hammer head at its high point. 14. M. C. Nokes, completing the ground turn by drawing back the left foot when the hammer-head is at its low point. 15. M. C. Nokes, completing the final turn and reaching the throwing stance with hammer well out to the right. 16. A. E. Flaxman. The reverse; the body is now facing the direction of hammer flight. This breaking-up movement follows the delivery shown in Fig. 45 (page 317).

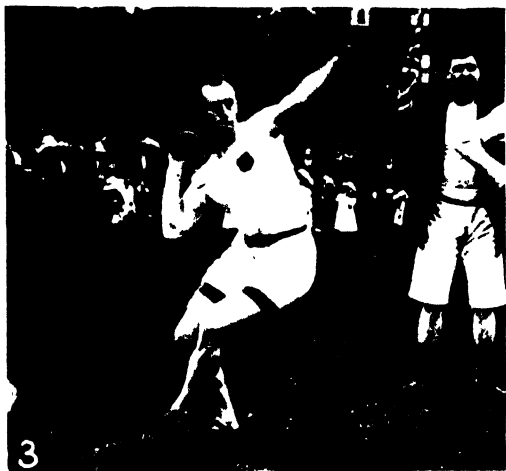

3
PL. 58]

4
Sport and General. [Y 321

PUTTING THE SHOT.

1. The Author and Dr. R. S. Woods working out points of technique at Fenner's, 1914. 2. D. Horgan, Great Britain, Irish style, starting position. Note balance of shot on fingers. 3. W. E. B. Henderson, Great Britain, Scottish style, leg in front swing to begin the glide. 4. H. Brix, U.S.A., American starting position. Note shot hold and arm position.

CHAPTER XXII

PUTTING THE SHOT

WEIGHT putting is almost as old as the hills, from which the rocks were reft which supplied the first contestants for athletic honours with their missiles, but one cannot ascribe a period to the institution of the sport ; although, certainly, stone putting is mentioned in the Book of Leinster, as providing an event at the Tailtin Games inaugurated in Ireland in 1829 B.C. Unfortunately no reliance can be placed in the recorded achievements of the ancients, since Scott, in " The Lady of the Lake " tells us that one, Douglas, beat all his opponents by a rood—a little more than 104 feet—obviously an impossible performance.

In the Middle Ages weight putting seems to have been so popular in England that Edward III prohibited the pastime by statute, because he feared that the sport might replace the practice of archery. To the best of my knowledge that statute has never been repealed, and so shot putting is still an illegal sport. Henry VIII, however, made athletics fashionable in England and numbered among his daily exercises " casting of the barre," in other words, hammer throwing and weight putting. With the coming of artillery, the more handy cannon-ball began to replace the rugged fragment of rock chosen haphazard from the hillside, and in time the weight of the cannon-ball used for the purpose was standardized at 16 lb. The term " Weight Putting " derives from the old table of weights and measures, wherein 16 lb. was classified as a " weight " and 14 lb. as a " stone."

A 16 lb. iron shot was used at Dublin University Sports Meeting in 1860, at the Oxford and Cambridge Sports in 1865 ; and, when the famous New York A.C. was founded in 1868, among the first impedimenta purchased were an iron shot,

hammer, and 56 lb. weight. At the first English Championship Meeting, 1866, however, the weight of the shot was accidentally 18 lb. 10 ozs., and C. Fraser, London, must have been a strong man indeed to reach 34 ft. 10 ins. with it. By a curious coincidence the shot was again over-weight sixty years later when Dr. R. S. Woods, C.U.A.C. (No. 1, Plate 58 and No. 4, Plate 60), made the present British Nation record of 44 ft. 11 ins. I believe that I am correct in stating that the first man ever to beat 40 ft. was E. J. Bor, a gigantic Royal Engineer, who was a member of the London A.C. In 1872 he took the English title at 42 ft. 5 ins., and retained it in the following year with a put of 40 ft.

The preceding years were notable for the performances of H. Leeke, C.U.A.C., and R. J. C. Mitchell. In 1868 Leeke won the English hammer throw at 99 ft. 6 ins., the following year he took the Oxford and Cambridge hammer throw at 103 ft. 11 ins., and the English shot put at 31 ft. 4½ ins., and was English Hammer Throwing Champion again in 1870 (102 ft. 0 ins.), and 1872 (111 ft. 7 ins.). A love of heavy weight field events runs, evidently, in this family, for in 1903 his son took the Oxford and Cambridge hammer (126 ft. 8 ins.) and shot (37 ft. 2 ins.), and in 1906 won the English hammer throwing title at 123 ft. 1 in. In 1908, Henry Leeke, the younger, represented Great Britain at the Olympic Games in a number of events and in 1911 won the 56 lb weight slinging championship at 25 ft. 2½ ins. He was a genial young giant in those days, a good 6 ft. 3 ins. in height and as blond and brawny as the popular conception of a Viking.

The day of that first English 56 lb. weight slinging championship I shall long remember. It was held at a sports meeting at Mayland in Essex. George Hogsflesh, now Assistant Secretary of the A.A.A., met us as we got out of the train, and the first question he asked was—had we brought our weights with us? It was a broiling hot day, and the answers that came from Leeke and Edward Barrett were amusing but unprintable. Finally, we all trooped round to the local butcher's and borrowed a half-hundredweight for the competition.

There was an amusing incident in connection with the shot putting on the same day, and I have often wondered since if the local "bobby" was more erudite than the rest of us, although we had a couple of rising barristers in the competition. Anyway, we beat up the local talent in the eliminating round, and I know I scraped into the final—thanks to a most generous handicap allowance. There never was a final, however, for an official was nearly brained through getting in the way of the shot, which the policeman promptly impounded, so perhaps, after all, he had heard of Edward III's statute.

To revert, however, to early history. R. J. C. Mitchell, of Manchester, was a whale of an all-rounder. His championships are :

	Long Jump.	High Jump.	Pole Vault.	Shot Put.
1868	19 ft. 8½ ins.	5 ft. 8 ins.	10 ft. 6½ ins.	—
1870	19 ft. 11¾ ins.	5 ft. 9 ins.	10 ft. 3 ins.	33 ft. 0 ins.
1871	20 ft. 4 ins.	5 ft. 6 ins.	10 ft. 1 in.	38 ft. 8½ ins.

A wonderful list of performances which indicates that a good jumper may often make a fine shot putter and *vice versa*. This has been often proved and especially in the latest instance of A. I. Wahlstedt, who in 1928 won the Finnish high jump championship at 6 ft. 1 in. and took the shot putting title at 47 ft. 6 in.

From Bor's time, up to 1882 no athlete succeeded in beating 40 ft. in the English Championships, but that year a Northern policeman, G. Ross, from Patricroft, returned 42 ft. 4 ins. His record was beaten in 1885 by D. J. Mackinnon, a very hefty forward of the London Scottish R.F.C., at 43 ft. 0½ ins.

Ross, I am told, had a style of his own which often troubled the judges, for the rule required that "the weight shall be put from the shoulder," but Ross, who was neither big nor quick, had an enormously strong arm and took full advantage of it. His action led the onlookers to believe that he was about to

bowl the shot, but just before the delivery he snapped his elbow into his side and so got it behind the shot and the hand to the shoulder in the orthodox position.

Prior to his day W. G. Winthrop, C.U.A.C. and L.A.C., took three titles and almost reached 40 ft. He was a man who loved to use his tremendous strength, and many of his feats are now legendary, such as the uprooting with his bare hands of a flagstaff at a certain seaside resort.

J. S. Mitchell, who succeeded McKinnon, was one of the Irish giants. In 1885 he commenced his athletic career as a sprinter of considerable merit, but in 1886 turned his attention to the shot and hammer events and took the English titles at 38 ft. 1 in. and 110 ft. 4 ins. respectively; between that year and 1905 he took five English, seventeen Irish, twenty-five U.S.A. and fourteen Canadian national championships, besides twenty American Metropolitan titles in weight putting, hammer and discus throwing. His best event was the 56 lb. weight, in which his world's record of 35 ft. 10½ ins. stood from 1894 until Matt McGrath, U.S.A., raised it to 40 ft. 6¾ ins. in 1911, but Mitchell reached 145 ft. with the 16 lb. hammer and was always right in the first flight of shot putters. He was certainly due to win the 14 lb. stone throwing event at the Athenian Olympic celebration in 1906, in which Georges Georgantas, Greece, at 65 ft. 4½ ins. beat M. Sheridan, U.S.A., 62 ft. 4¾ ins., Mitchell having been one of the half-dozen men aboard the *Barbarossa* who were knocked over by a big wave the second day out from New York, and as his shoulder was dislocated he was unable to compete at Athens.

America throughout the eighties had a great shot putting champion in F. L. Lambrecht, Pastime A.C., who took the record up to 43 ft. But in 1887 George Gray, a medium-sized Canadian of under thirteen stone, whose physique did not appear remarkable, took the American title at 42 ft. 3 ins. In the following year he was again American champion at 42 ft. 10½ ins., and also crossed the Atlantic to win the English title with a new championship record of 43 ft. 7 ins., upon which performance he improved at Dublin in the same month by



Sport and General.



Pl. 59] *D.S.I.*

[*Y* 324

PUTTING THE SHOT.

1. G. Hartranft, U.S.A., showing commencement of glide, American style. 2. R. Rose, U.S.A., former World's Record holder (51 ft.), showing jump across circle. 3. E. Hirschfeld, Germany, showing the correct glide action. Note shot at neck, elbow behind it, and flexion of left knee. 4. R. L. Howland, Great Britain, American style. Note high leg lift and balance work of left arm.

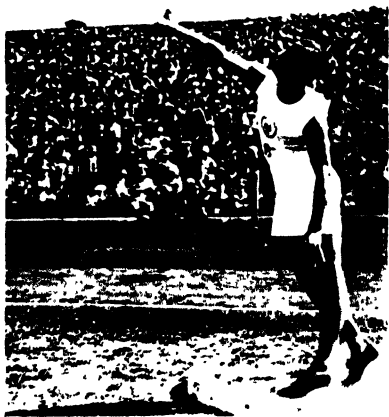

PL. 60]

Sport and General. [Y 325

PUTTING THE SHOT.

1. K. H. Pridie, England, in the perfect delivery position. 2. J. Kuck, U.S.A. Note final wrist flick. 3. W. W. Coe, U.S.A. showing finish of standing put (American style). 4. Dr. R. S. Woods, Great Britain. Put with reverse, showing fine shoulder and arm work.

returning 44 ft. 9 ins. In 1892 he raised the U.S.A. record to 47 ft. at Chicago. He was certainly the best shot putter of his inches that the world has ever seen, or is ever likely to see, and a shining example of just what may be accomplished by the man who will "take thought to add a cubit to his (lack of) stature." His timing and muscular co-ordination were simply marvellous.

By this time the standard had risen nearly a dozen feet and the Continental and Scandinavian nations were beginning to practise athletics seriously, although their day was not yet come. In 1889 Dennis Horgan (No. 2, Plate 58), a most genial Irish giant and hero of many a great conflict, had raised the world's record to 47 ft. 1 in. in Scotland, and in 1894 W. O. Hickok, Yale, set the American Inter-Collegiate record at 42 ft., and a year later J. D. MacIntosh raised the Scottish Championship record to 43 ft. 1 in. Meanwhile, the nearest approach to 40 ft. at the Oxford and Cambridge Sports had been the 39 ft. 1 in. of J. H. Ware, O.U.A.C., in 1886.

Dennis Horgan, I think, deserves a special paragraph to himself; were all his feats to be recorded, he would need a whole volume. Born at Banteer, Co. Cork, in 1879, he was twenty-four years of age when he won his first championship honours in 1893, taking the Irish Shot at 45 ft. 3 ins. and the English title at 42 ft. 9 ins. Between that year and 1912, when he was forty-three years old, he won eleven Irish A.A.A., and thirteen English titles, besides Canadian and American shot putting championships. He never gained an Olympic title, but in 1908, in a downpour of rain, was beaten a couple of feet by the late Ralph Rose, U.S.A. (No. 2, Plate 59), who registered 46 ft. 7½ ins. At that time Horgan stood 5 ft. 10 ins. and weighed 17 st.

There is a tale told of him which illustrates the dangers of imitating the mighty too closely. Horgan, getting on in years, is said to have stimulated his energies with a "drop o' the crather" upon occasion. Another athlete, observing this, provided himself with a flask of whisky, and found that the stimulant added to his shot putting powers. Unfortunately he had recourse to similar measures before going out to throw the

hammer, and the whirling motion combined with the potent spirit landed him flat on his back.

Ralph Rose (No. 2, Plate 59) the world's master for many a year, and W. W. Coe (No. 3, Plate 60), both now dead, were contemporaries. Coe, who was born at Boston, Mass., U.S.A., ten years after Horgan first saw the light of day in Ireland, was of just the same height and weight as the Irishman, and, save for consistency, the better putter. In 1900, as an unattached athlete, he won the first Junior Championship of America at 43 ft. 8 $\frac{3}{4}$ ins. with the full-sized shot ; a year later he came over to England to take up a Rhodes Scholarship at Oxford, and won the A.A.A. title at 45 ft. 5 $\frac{1}{2}$ ins. The next year he did 42 ft. 10 $\frac{1}{2}$ ins. and also established the still unbroken Oxford and Cambridge Sports record of 43 ft. 10 ins. He was back in America in 1905 and won his first U.S.A. title with a new world's record of 49 ft. 6 ins. and held it again the following year at 42 ft. 10 $\frac{1}{2}$ ins., exactly the same measurement as gave him fourth place in the 1908 Olympic contest. He was often in England up to the time of his death and did much to make Rex Woods, the C.U.A.C. Honorary Treasurer, the great shot putter he undoubtedly is to-day.

Rose was a very different sort of human proposition from the other two, for he stood 6 ft. 5 $\frac{1}{2}$ ins. and stripped at 16 stone 6 lb. when he was twenty-two years of age, and won the 1908 Olympic Championship. He was born in California and for a time studied law at the University of Chicago. As a boy he showed considerable athletic promise, which was confirmed in his first championship appearance, when at eighteen years of age he made a new Olympic record at the St. Louis Games of 48 ft. 7 ins., but he did not win his first National American title until 1907, in which year he tacked half an inch on to W. W. Coe's world's record, and it was predicted that 50 ft. would at last be beaten at the forthcoming Olympic Games of London. The weather, however, denied Rose the new record, but he reached 47 ft. 2 ins. in an exhibition put with a slippery shot, and at Killmallock, Ireland, on August 9th, 1908, established the present British record of 49 ft. 3 $\frac{1}{2}$ ins. In America he went

on to beat 50 ft. and a year later finally hall-marked his career by recording 51 ft. As yet no one other than an athlete of the English-speaking nations had won an American or English title, although we had seen some remarkably promising Finns in London in 1908, and a likely Hungarian in I. Mudin.

At the Stockholm Olympiad, 1912, the Scandinavians were expected to be well to the fore, especially in the additional event in which the best put right hand was to be added to the best put left hand to arrive at the winning aggregate. Rose, in the years between, had increased in weight up to 20 stone and although only twenty-six years of age was said to be getting stout. And certainly he had a Falstaffian paunch, which swung before him as he progressed across the circle, but the added weight did not seem to me to have impaired his form to any marked degree. In the best hand event America took four out of the first half-dozen places. P. MacDonald, who had won the last two American Championships, put 50 ft. $3\frac{1}{10}$ ins., as against Rose's 50 ft. $0\frac{1}{8}$ in., but Finland supplied the fourth man in E. Niklander, 44 ft. $9\frac{3}{8}$ ins., the Hungarian I. Mudin, was sixth at 42 ft. $0\frac{3}{10}$ in., and the first Britisher was the Irish champion, P. Quinn, who was placed eighth at just over 41 ft., a full 2 ft. below his proper form.

In the two hands aggregate contest Rose took his revenge upon MacDonald in a terribly close contest, which resulted—Rose, right hand 49 ft. 6.5 ins., left hand, 40 ft. 10.9 ins. = 90 ft. 5.4 ins.; MacDonald, right hand, 49 ft. 5.7 ins., left hand, 40 ft. $10\frac{3}{10}$ ins. = 90 ft. $3\frac{1}{8}$ ins.; while E. Niklander, the Finn, was third at 89 ft. 0.05 ins.

Niklander had done well also in both discus events, and it occurred to me at the time, with a sort of admiration not unmingled with anger, that America was moving heaven and earth to master the intricacies of the almost purely Scandinavian event, while the Scandinavians were striving equally hard to get the hang of the shot put, but Great Britain was standing aside and making no attempt whatsoever to make her men efficient in any one of the four throwing events, two, if not three, of which had had their origin in British soil.

Athletics of To-day

Just prior to coming to Stockholm Rose had made yet another new world's record with an aggregate total of 91 ft. 10½ ins., in which he put 50 ft. 6 ins. with his right hand and 41 ft. 4½ ins. with his left hand. This record still stands unbroken, although two Americans and one German eclipsed his best hand record of 51 ft. at Amsterdam in 1928.

Before the 1912 Olympiad, R. S. Woods put up a surprisingly fine school record at Dulwich College of 37 ft. 7 ins. When I saw him as a Freshman at Fenner's shortly afterwards I gained the impression that he was going to be very good indeed, and he proved it with a record in the Freshmen's sports of 35 ft. 6 ins. I had the pleasure of working with him on points of style in February, 1914, and a month later he won the Oxford and Cambridge event at 41 ft. 1 in., and, having served all through the War, won the event again in 1920 at 40 ft. 3 ins. He is undoubtedly the best shot putter England has yet produced and holds the English native record of 44 ft. 11 ins., made with an over-weight shot in the English Championships of 1926, but his best effort of all, so far, was in 1927, when he went on tour with the Achilles Club to Athens and established a new Greek record of 45 ft. 1½ ins. Dr. Woods stands 5 ft. 11½ ins. and weighs 12 st. 3 lb., but has extraordinary quickness and co-ordination, combined with speed (51 secs., ¼ mile), strength, and the patience which enables the athlete to master the finer points of his art. He has represented England in many international matches, Great Britain twice at the Olympic Games, and also the British Empire against the United States of America. His work for the future of British athletics has been remarkable. He was the first Cantab to beat 40 ft., and since he has coached the C.U.A.C. (1920-29), this event has never been won at under 40 ft. at Cambridge. R. L. Howland (No. 4, Plate 59) owes everything to him, and Dr. Woods is at present shaping two possible champions in J. P. Wallace and R. M. N. Tisdall.

The first post-War Olympiad, held at Antwerp in 1920, saw the last of the old American generation of shot putters, and the Scandinavians beginning to achieve the results for which they had worked so hard. In the eliminating trials Niklander led

McDonald, both of them veterans of Stockholm, by 3 inches at 46½ ft., but a new Finlander, Ville Pörhölä (No. 3, Plate 61) was also beating 46 ft. Personally, I thought Pörhölä would win and break Rose's eleven-year-old record of 51 ft. A few days earlier, when Ernie Hjertberg, the Swedish Olympic coach, and I were together on the training ground, we had watched the husky young Finn at work and had decided that he would get a lot further if he kept his chin up in making the delivery. Hjertberg went across and gave him the tip. He acted upon it, and his next put, which we measured, was over 52 ft. In the actual competition, however, he dropped his head every time as he thrust the shot forward, and so had to be content with 48 ft. 7½ ins. for his win in the final, in which Niklander and McDonald did not improve upon their preliminary performances, H. Liversedge, U.S.A., displacing his countrymen for their honours with a put of 46 ft. 5 ins., an eighth of an inch behind Niklander, while E. Nilsson, Sweden, was fifth, and A. Tammer, Esthonia, sixth.

Had Pörhölä been coached by a great expert like Hjertberg I think he would have done over 53 ft., but when he came to England in 1922 and set the A.A.A. Championship record at 47 ft. 10 ins. the same fault of dropping the head was still painfully in evidence. Incidentally E. Nilsson, placed fifth at Antwerp in 1920, was the first foreigner other than an American ever to win an English Championship, when, in 1913, he increased our record to 47 ft. 4½ ins. ; since that time no British athlete except Dr. R. S. Woods, in 1924 and 1926, has held the English Championship title.

The severe shaking United States athletes received in the field events at Antwerp evidently set the Americans to putting that particular part of their athletic house in order. And if there is one point more admirable than another about the Americans it is their thoroughness. Their old shot putters had reigned perhaps a thought too long, but there was good material in the schools and notably Ralph Hills, of Hill School, Portsdown, who in 1920 raised the American Junior 16 lb. shot putting record to 44 ft. 10 ins., Clarence Houser (No. 2,

Plate 61) who was a bit younger, and John Kuck, Wilson's High School, Kansas City (No. 2, Plate 60), who was younger still. The first two and Glen Hartranft (No. 1, Plate 59) were to be the "big bets" for America at the Paris Olympiad, 1924. Kuck was to be kept for 1928.

Before ever the American Team embarked for France the new generation had made its mark. Clarence Houser took the A.A.U. title at 46 ft. 11 $\frac{3}{4}$ ins. in 1921, and Glen Hartranft the Inter-Collegiate title, 1922, at 48 ft. 6 $\frac{1}{8}$ ins.; he was displaced in 1923 by R. G. Hills, 47 ft. 8 $\frac{3}{4}$ ins., but made a new Inter-Collegiate record of 49 ft. 5 $\frac{7}{8}$ ins. in 1924. The stage was now set for Paris, and Hills won the A.A.U. Outdoor Championship at 46 ft. 5 $\frac{3}{4}$ ins. and the indoor title with a new record of 47 ft. 11 $\frac{1}{2}$ ins.

The American Olympic trials that year produced amazing results—Houser 49 ft. 11 $\frac{1}{8}$ ins., Hartranft 49 ft. 0 $\frac{1}{4}$ in., Hills 49 ft., and Anderson 48 ft. 8 ins. All four had beaten the best achieved by Pörrhölä at Antwerp, while Liversedge, third at Antwerp, could get no nearer than sixth at 47 ft. 3 ins. in the 1924 U.S.A. trials. There was no doubt about the Americans being after the blood of the men who had beaten them in 1920, and in no other country had a national title been won at anything like Liversedge's sixth place distance, although E. Niklander, Finland, and Bertil Jansson, Sweden, both did a little better than 46 ft.

At Paris, Niklander, second at Antwerp, could get no nearer than sixth place, with a put of 46 ft. 9 $\frac{5}{8}$ ins. No record was broken, but the standard of performance had increased considerably which, together with the keenness of the competition, is proved by the following statistical results:

			ft.	ins.
1.	C. Houser, U.S.A.	49	2 $\frac{3}{8}$
2.	G. Hartranft, U.S.A.	49	2
3.	R. H. Hills, U.S.A.	48	0 $\frac{5}{8}$
4.	K. J. Torpo, Finland	47	4 $\frac{7}{8}$
5.	N. Anderson, U.S.A.	46	10 $\frac{1}{8}$
6.	E. Niklander, Finland	46	9 $\frac{5}{8}$

America and Finland were now right on top in the shot putting business, but America, with her far greater constituencies of athletes, had the better chance of producing a new world's record breaker.

In 1925 Houser took the A.A.U. Championship record up to 50 ft. 1 in., and was followed by Herbert Schwarze. The latter was a second and perhaps bigger Ralph Rose in build and, I believe, a fine high jumper also, despite his enormous height and bulk. In 1925 he took the English title at 47 ft. 3 ins., and in 1926 the American title at 49 ft. 10 $\frac{7}{8}$ ins., and yet failed to secure a place in the American Olympic team of 1928.

John Kuck, meantime, had emerged from his high school cocoon and had entered the Kansas City State Teachers College. In 1925 he took the U.S.A. junior title at 48 ft. 2 $\frac{3}{4}$ ins., but had his record disallowed because of the weather conditions. A year later he placed second to Schwarze in the senior championship with a put of 48 ft. 11 ins., and beat Clarence Houser. In the National Collegiate Championship he gained first place at 50 ft. 0 $\frac{3}{4}$ in., again beating Houser, and became National Champion in 1927 at 48 ft. 5 ins. Just prior to the 1928 Games he at last succeeded in breaking Rose's sixteen-year-old record of 51 ft., but only by half an inch, although a friend wrote me from the States that Kuck was repeatedly doing better than 52 ft. in practice.

Even so, Kuck was not by any means the only bright pebble upon the world's beach. In 1927 Kalle Jarvinen (No. 4, Plate 61), the nineteen-year-old son of the first athlete ever to send the flag of Finland to the Olympic's masthead, never once failed to beat 48 ft., and twice went within an inch or so of the 50 ft. mark. Wahlstedt, the Finnish high jumper and shot putter, J. Daranyi, Hungary, E. Krenz, U.S.A., E. Duhour, France, and G. Brechenmacher, Germany, were all in the 48 ft. class, while Bertil Jansson, Sweden, had done 49 ft. 6 ins. The most dangerous rival to Kuck, however, seemed likely to be the big German, E. Hirschfeld (No. 3, Plate 59). In 1926 he was eighth on the German list at 43 ft. 11 $\frac{5}{8}$ ins., in 1927 fifth at 47 ft. 5 $\frac{1}{2}$ ins., while W. Uebler had hardly been heard of.

Athletics of To-day

In these two years, incidentally, the German "best ten" standard rose from 43 to 47 ft.

Early in 1928 Hermann Brix, hitherto not likely to be considered for the American team, beat 50 ft. In Germany Uebler came right into the picture, and Hirschfeld suddenly found his form. No sooner had Kuck broken world's record than Hirschfeld bettered it at Dusseldorf with a put of 51 ft. 9½ ins., and later did 51 ft. 3⅛ ins.

At Amsterdam, needless to say, I watched the performances of this big bunch of world beaters with the keenest interest. Wahlstedt and Uebler both equalled 48 ft. 2½ ins. exactly, while Brix, with his very first heave, tossed out the 16 lb. shot to a new Olympic record of 51 ft. 8 ins., thus displacing Pat McDonald's sixteen-year-old figures, while his fellow American, Eric Krenz, did 49 ft. 2 ins. Hirschfeld reached 51 ft. 6¾ ins. at his third attempt, and Kuck, at his second attempt, took the world's record up to 52 ft. 0⅛ in., but even more wonderful, perhaps, is the fact that in not one of his six puts did Kuck do less than 50 ft.

Three weeks later at the big match in London the Americans beat the British Empire soundly with an aggregate of 145 ft. 11 ins. (H. Brix, 49 ft. 6 ins., J. Kuck, 49 ft. 4½ ins., and H. P. Rothert, 47 ft. 0¼ in.) to the Empire's 125 ft. 8 ins. (R. S. Woods, G.B., 42 ft. 8 ins., H. Hart, S. Africa, 42 ft., and R. L. Howland, G.B., 41 ft.).

R. L. Howland I believe to be one of Britain's big hopes for the future; he is young enough yet, dead keen, and has the height and build for the game. Before Howland went up to Cambridge from Shrewsbury, H. M. Austin, an Australian, had eclipsed Woods's Freshmen's record by achieving 36 ft. 11 ins., while Howland in his first sports at Fenner's accomplished 35 ft. 1 in. After that he won the Oxford and Cambridge event from 1926 to 1928, doing 40 ft. 4 ins., 42 ft. 2 ins., and 42 ft. 10 ins., and holds the new Fenner's Ground record at 44 ft. 10 ins. (1928). There is also great hope for R. M. N. Tisdall, also of Shrewsbury, who in 1928 made a new Cambridge Freshmen's record of 38 ft. 4½ ins., and has since beaten 40 ft. He had no style at



PL. 61]

Spot and Gener. [Y 332

PUTTING THE SHOT.

1. J. Daranyi, Hungarian Record holder, showing delayed reverse action with good wrist and finger work. 2. C. Houser, U S A , former Olympic Champion, showing finish of reverse. 3. V. Porhola, Finland, former Olympic Champion. 4. K. Jarvinen, son of Finland's first Olympic champion. 5. Dr. R. S. Woods, C U A C. and Great Britain, British Native Record holder.

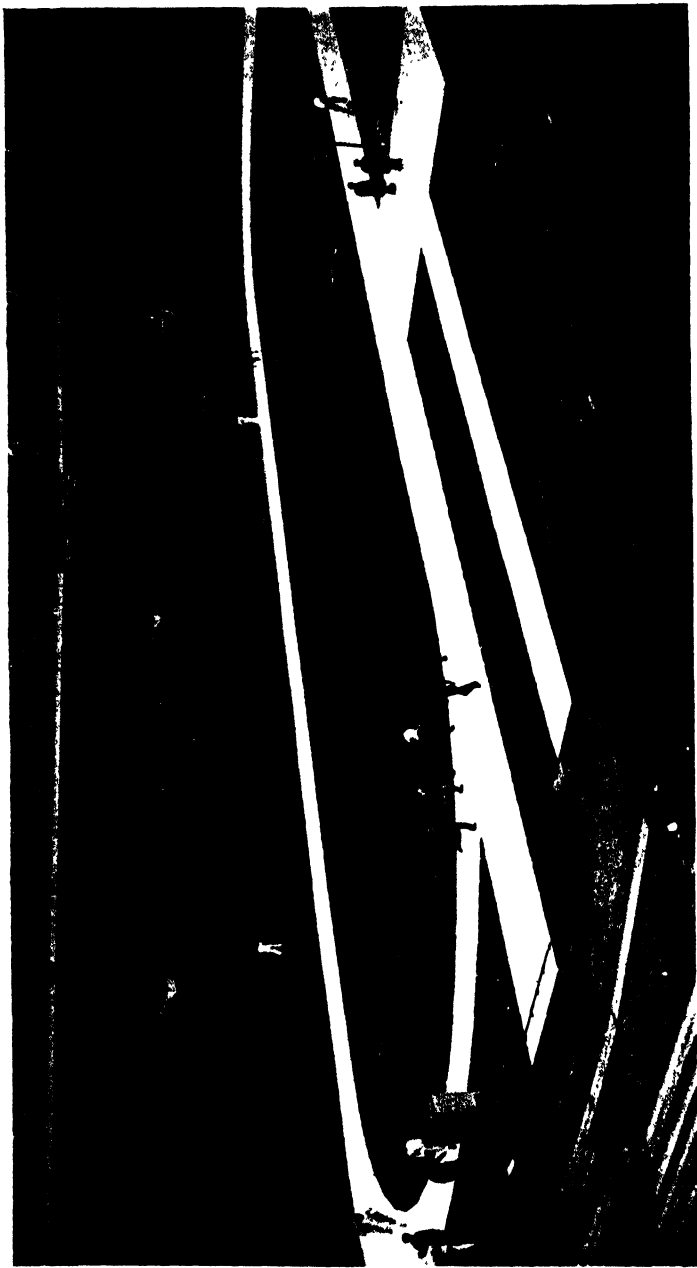

PL. 62]

WHERE AMERICA SCORES.

Sport and General. [Y 333

Franklin Field, Philadelphia, is among the best of America's many, magnificent athletic grounds. In bad weather, board tracks are put down so that training may continue.

first but exceptional natural athletic ability, which was shown also in his hurdling and sprinting. Britain has other exceptionally good performers, considering the meagre facilities for competition that are afforded, in Captain J. A. Ross, H.L.I., Lt. C. E. Beckwith, Northumberland Fusiliers, and K. H. Pridie, University of Bristol, all of whom are in the 44 ft. class.

Since 1865, when the first Oxford and Cambridge event was won at 31 ft. 4½ ins., the world's record has been increased in some sixty odd years by approximately 20 ft. 8¼ ins., but the English native record has risen by only 7 ft. 1¾ ins. The reason for the latter circumstance is easily explained by lack of proper coaching at the schools and the difficulty all shot putters experience in getting anything like a reasonable amount of competition. But we can hope for great improvement now that the London A.C. has decided to include a 12 lb. shot put in the Public Schools Sports programme. For years past competition in this event at our public schools has been confined almost entirely to the rowing men and Rugger forwards. They alone possess the strength to propel the 16 lb. missile, but seldom have the time to spare from their other sports to master properly the timing and technique of the event.

Fifty years ago H. C. Gaches—a son, I believe, of a former Town Clerk of Peterborough—won the Merchant Taylors' School shot put at 27 ft. 5 ins., Sir Montague Shearman, now President of the A.A.A., taking the same event in 1874 at 30 ft. 4 ins. and in 1875 at 34 ft. 4 ins. In comparison with Sir Montague's school record of just over half a century ago, which was probably a Public Schools record at that time, is the fact that in 1928 new school records were made at Rugby, A. J. Martin 36 ft. 10 ins., and Mill Hill, T. H. B. Lawther, 36 ft. 0½ in., while H. A. V. Hogan, Malvern, reached 34 ft. 7 ins., and B. S. Bennett, Bloxham, 34 ft. 4½ ins., and 30 ft. was beaten at practically all the schools that still include the event. The standard of performance has therefore increased considerably, and obviously there is a wealth of undeveloped talent in the country.

What then is the reason why shot putting is not more popu-

lar? The answer is that the boys should never have been allowed to use a 16 lb. shot. I admit that boys such as those just mentioned can evidently manage it, but there are hundreds upon hundreds of others, not so fully developed, who not only strain themselves by trying to juggle with so heavy a weight, but who find it impossible to propel in the proper style a missile which it is beyond their strength to control.

Shot putting is a good, healthy, body-building game for a boy to practise, but the Americans and Scandinavians got to the heart of the matter when they decided to standardize shots of three weights, *i.e.*, the 8 lb. shot for boys of fifteen years and under, the 12 lb. shot for boys of sixteen to eighteen years, and the 16 lb. shot for exceptionally well-developed youths and fully grown men.

The general standard of world-wide improvement is not, however, to be so readily explained. There may be something in the theory that the march of progress has endowed us with far keener nervous perceptions than were possessed by our forefathers, and so given us more complete muscular co-ordination; but, physically, and in foot-pounds of muscle value, we are no better than they were. The problem, therefore, must reduce itself to the old formula of "man and his methods."

In the early days of weight putting the missile, in all probability, was bowled more often than not, for a big, long-armed, deep-chested fellow of exceptional strength can generally "draw" a shot further than he can "put" it, and old pictures seem to indicate that the initial momentum was generated with a run. Then came the days in which putting took place from a 7 ft. square, and all puts were measured from the mark in the ground made by the shot to the front edge of the square, or that edge produced, so that straightness in putting was a necessary part of the athlete's technique. He was recommended to stand at the rear of the square with the right shoulder well drawn back (it is assumed throughout that the put is made with the right hand) and to raise the shot several times above the head to stretch the arm

and side muscles. A hop of about 3 ft. forward was then taken, and the landing made on both feet with the weight on the right leg, and the body right back. The left leg did very little work, for the right at once started a spring forward in which the body was twisted to the left so that the right leg and side were in front when the right arm shot out to effect the put, and the left leg was swinging free with both feet off the ground. But when the boxer leads with his right he does not have his foot off the ground, nor the right foot in front. On the contrary, the boxer's left foot is forward and the power of his right hand punch is generated in the sole of his right foot.

As soon as this mechanical principle was appreciated, there began a marked improvement in shot putting. In 1908 the 7 ft. square, as the putting area, was replaced by a 7 ft. circle. This gave the shot putter the advantage of delivering his missile in any direction, since the put was measured from shot mark to circle edge on a line with the centre of the circle.

Then the Scandinavians hit upon the notion that the left leg and stiffened-up left side should be used as a means of resistance to the effort. This introduced a definite check, producing the jerk referred to in Chapter XIX (Throwing the Javelin). Horgan added a slight shoulder swing combined with a mighty heave up from a low point to the technique. But this was corrected later to a cross twist of the shoulders from right to left to start the delivery, and the preliminary leg raising also was altered. Older generations had been accustomed to raise the left leg and carry it across in front of the right leg to start the glide as shown in Picture No. 3, Plate 58, of W. E. B. Henderson, O.U.A.C., and L.A.C. In later days it became customary, however, to dispose the body as shown by Herman Brix, U.S.A. (Picture No. 4, Plate 58) with the shot held close into the ear, elbow directly behind it, and weight resting on the right leg. The left leg was then raised and swung to a position behind the body, as the left arm was allowed to fall to commence the glide across the circle, as shown in A of the accompanying

illustrations (Fig. 47). The jump forward was then toned down to a very smooth glide in which the feet pass only just above the ground. The start of this glide is shown in sketch B, Fig. 47. It will be seen that the right foot does not leave the ground until the thighs are at full stretch. Note especially that the left leg is kept bent at the knee, the body is drawn well back, and the right elbow is held directly in rear of the shot.

Now look at the diagrams in Figs. 48 and 49. In the American style the athlete places his feet as shown at R₁ and L₁. The left leg is then raised as shown in Picture No. 4, Plate 58, and swung behind the right leg to point X; without any check in the movement, it then goes forward again on a long

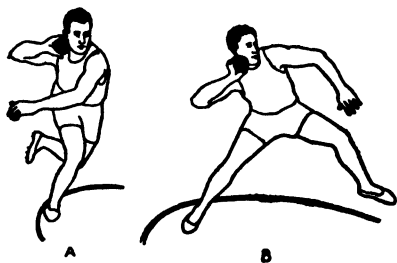

FIG. 47

swing, started with an increasing kick action (see Pictures Nos. 1 and 4, Plate 59), the right leg drives off, shifting the balance past the centre of the circle and the athlete lands flat on both feet at R₂ and L₂, with the right shoulder drawn well back and the

right knee bent.

The Americans have yet another method of making the glide. In this the athlete lands with his right foot well beyond the centre of the circle and the feet much closer together, so that he gets the drive off both legs. This is the method used by Clarence Houser. In both cases the glide starts slowly and pace is put into the evolution as the feet land at R₂ and L₂.

The Americans make the Reverse a part of the glide and delivery actions. When both feet are down the final effort commences from the ball of the right foot and is carried on by the straightening of the right leg, the body is twisted from right to left, and the shoulders are pressed forward as the left leg is stiffened; the right arm then shoots out, and the shot is dispatched with a final flick of the wrist and fingers. The feet

are reversed simultaneously with the departure of the shot (see Picture No. 4, Plate 60), and great care is taken to bring the right side of the foot against the stop-board at R₃ and to have the right hip pointing in the direction of the put, as the left leg swings back and up to help to maintain the balance (see No. 2, Plate 61). The shot is dispatched at an angle of 45 degrees, and the head is pressed back so that the eyes may follow the flight of the missile.

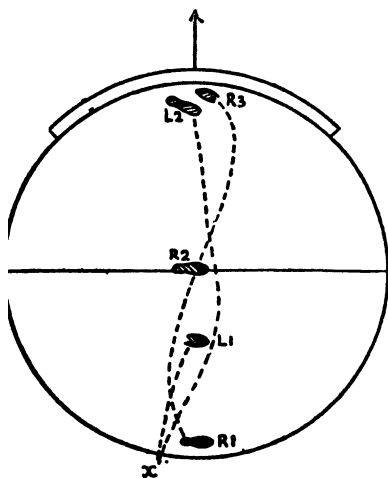

AMERICAN STYLE

FIG. 48

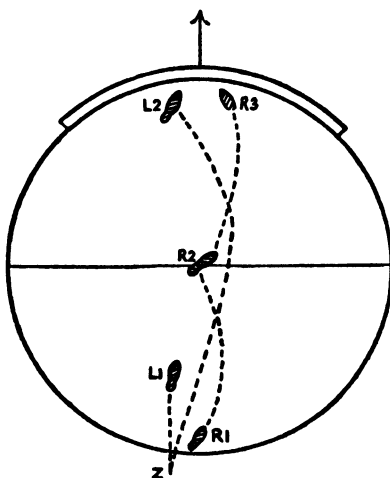

SCANDINAVIAN STYLE

FIG. 49

The beginning of the American glide is seen in Pictures Nos. 1, 2 and 4, Plate 59. The delivery in Picture No. 4, Plate 60, of Dr. R. S. Woods, C.U.A.C., shows fine finger and wrist work of right hand and that the reverse of the feet has already commenced. The left shoulder, however, should not have been dropped. Perfect action is that of J. Kuck (No. 2, Plate 60). The finish of the reverse is seen in Picture No. 2, Plate 61, in which Clarence Houser has got the outside of his right foot well against the stop-board at R₃, and he has also kept his left shoulder well up to the level of his right.

The Scandinavian style looks much the same as the American to the casual observer. In many points it is vastly different. The initial stance and the foot placing throughout is more straight ahead. There is more forward body lean and less crouch in the commencing backward swing of the left leg (Fig. 47, page 326). There is also a much lower carriage of the left leg as it swings forward (see Fig. 47 B, and Picture No. 3, Plate 59, of E. Hirschfeld). Note also the forearm is directed downwards instead of being raised parallel to the ground as in the American style (see Picture No. 4, Plate 61, of R. L. Howland). In the Scandinavian style, too, the right foot lands alone at R2 (Fig. 49) and the body and shoulder are drawn back as shown in Fig. 50 and the left leg raised as a counterbalance. A fraction of a second before the left foot is stamped down at L2 the shoulders commence a violent twist from right to left. Directly the left foot is down the right leg begins to push the body, and especially the right hip, up and forward (see Picture No. 1, Plate 60, of K. H. Pridie. This illustration must be studied in all its details most carefully.) The left leg and side are stiffened, and the legs assume a walking attitude. As soon as the hips and shoulders are square to the front the right arm is fully and forcibly extended as shown in Fig. 51, and No. 2, Plate 60. Without any pause the legs are stretched, the body twisted to the left, and the right shoulder pressed after the shot so that although the body has twisted from right to left it leans to the right as shown in Fig. 52. Note the straight line through the body from right foot to right hand.

The fact that the reverse of the feet comes much later in the Scandinavian than it does in the American style will be appreciated by a study of Picture No. 1, Plate 61, of J. Daranyi, the Hungarian record holder.

In the Scandinavian style the power is provided first by the legs, increased by the rapid twisting of the shoulders, and the shot is given its initial velocity in flight by the jerk introduced by the check which imparts to the arm its final driving power for the delivery, but the wrist and fingers give the final flick for upward rotation. The athlete should try to lift his centre of

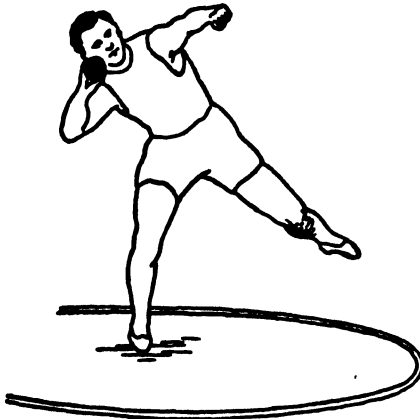

FIG. 50

Not only will this enable him to get better elevation, but it will also prevent his body from breaking to the left away from its work.



FIG. 51

gravity a little in the final effort, by pushing hard from the ball of the right foot and finishing the drive from the toes themselves. He should at the same time have the left leg so stiffened that he can come up on the toes of that foot also.

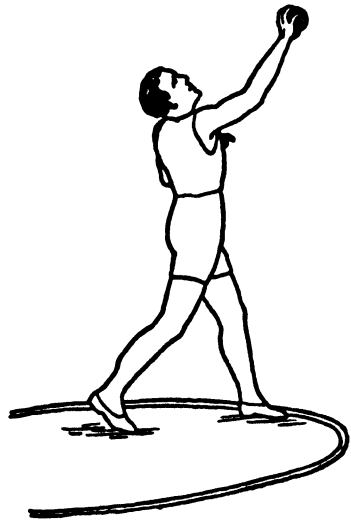

FIG. 52

First of all the novice should work with a light shot and practise standing puts only. If he is going to use the American method he should at once knit in the reverse, when he will end up in the position shown in Picture No. 3, Plate 60, of W. W. Coe, U.S.A. If he is

going to use the Scandinavian style he should hold the cross leg position shown in Fig. 52 as long as possible and then make a quick reverse with a short shift. During the period when he is working at the delivery as a single unit he may also be mastering the glide as a single unit. After about a couple of weeks of steady practice he should begin very slowly to combine the two parts as a whole, unified effort.

Always contrive to keep the shot well into the hollow of the neck just below the ear, until the arm shoots out in the delivery. In making the delivery shoot the shot forward along the line of the jaw. Many good puts are lost because the athlete lets the hand break out to the right and the body fall away to the left. Keep the chin well up and the head back and to the right. It is fatal to drop it forward.

Always train in a properly marked 7 ft. circle and with a stop-board. In the American style, practise the reverse from centre of circle to toe board frequently. Once this is mastered it should not be difficult to add to it the preliminary part of the glide and the subsequent delivery action. In the Picture No. 3, Plate 60, Coe is practising the reverse and delivery without the preceding glide movement. Keep all the muscles loose until the feet are set in the putting position at R2 and L2 (Figs. 48 and 49, page 337) and then put into the effort all that you have it in you to give.

TRAINING

Training calls for a lot of gymnastic work and plenty of exercises that will build up the body; sprinting and high jumping for speed and spring, long walks for stamina building, and half mile jog-trot runs to strengthen the legs should also be used as aids in training. Do plenty of body stretching exercises, to increase reach and length of arm drive, and heel and toe lifting exercises and skipping, to strengthen the calf, ankle, sole of the foot, and toe muscles.

An excellent method of gaining strength and "putting" skill is by means of a chest expander used as shown in the

Putting the Shot

341

sketches, Figs. 53 and 54. In the first position the athlete takes one end of the expander in his left hand, which is held with its back in the region of his left hip. The other end of the expander lies across his right palm, the hand being given the same position as it would have if the shot were in hand. The putting action is then gone through in slow motion time so that the body and right side and arm are working against the strength of the expander, the lower end of which the athlete keeps firm in its original hip position.

Of shot putters it has long been the popular opinion that "the good big 'un will always beat the good little 'un." But there are dangers about such a generalisation. Most big men

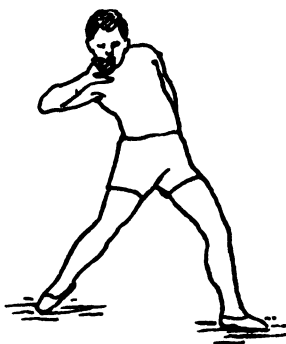

FIG. 53

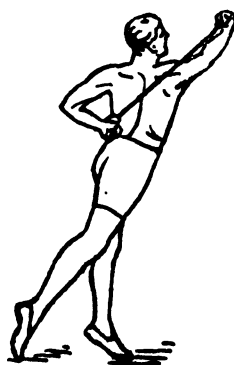

FIG. 54

are inclined to be a bit ponderous in their actions, while the small fellow often makes up in speed and co-ordination what he lacks in stature. In this connection, G. R. Gray has been already mentioned. There was also W. R. Knox, Canadian and British Olympic coach. He stood 5 ft. 8 ins. and weighed less than 11 stone, and yet attained the surprising distance of 46 ft., only 5 ft. less than Rose's world record, and Rose had the advantage of nearly 9 inches in height, besides weighing almost twice as much as the Canadian. It will be seen, therefore, that science and the appreciation of mechanical principles play an important part in shot putting.

Athletics of To-day

The diagram given in Fig. 55 shows the path described by the shot in its passage through the air. SA is the final and main propulsive force, accumulated in the glide and generated in the jerk which comes from the left foot resistance, right foot push, and the arm drive. It is obviously a "short" effort, in comparison with the length of the flight parabola ABD. The initial line of projection AC pronounces the correct delivery angle of 45 degrees from which the parabolic path ABD is entered upon.

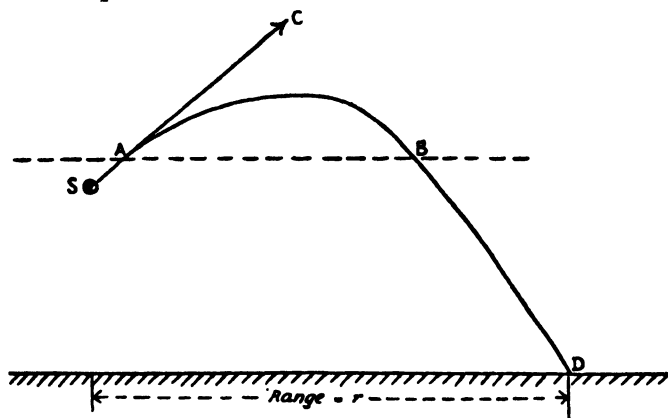

FIG. 55

If the average performance of the first three men throughout the National Championships in all countries during 1928 is examined it will be found that the world's standard has now risen to approximately 45 ft. In a put of that distance there is exerted a kinetic force of about 361 foot-lb., the shot leaves the hand with an initial velocity of 38 ft. per second, and the time taken to complete the range (r), or 45 ft., is 1.7 sec.

CHAPTER XXIII

SOME POINTS IN ATHLETIC SCIENCE

I HAVE often heard it said that the human limit in the way of record breaking must be very nearly in sight. But, so far from this being the case, I believe that we are at present upon the threshold of such fresh discoveries as will make possible far more startling records than any that have yet been established. There is far more in the "make-up" of a record breaker than simply speed and strength and skill. There are the moral qualities of pluck, patience, and perseverance, and the mental attributes of physical cleverness and comprehension. It is undoubtedly the development of a greater degree of physical cleverness, as the outcome of a more complete understanding of the why and wherefore of everything that takes place, that is going to bring about an altogether higher standard of general achievement. And this, in its turn, will be the result of the close scientific study of sport that is now engaging the attention of famous physiologists.

In the past, America has ruled the athletic world. Of forty-five world's running records at recognised distances, fifteen are held by Americans. Nearly all of them are at distances up to 440 yards, and the majority were made in California. Of ten relay records, America holds nine, Germany that for 4 x 1,500 metres. Of the six hurdling records, four belong to America and one each to Canada and South Africa. In the field events, the preponderance of America is even more pronounced than at the sprint distances. The United States holds ten, Finland two, and Australia and Sweden one each. At the running distances of over 440 yards, Great Britain comes into her own with eleven records, as against Finland seven, Sweden six, and

Athletics of To-day

France and Germany two each. The only short distance record not exclusively American is that for 100 yards, which has been equalled by a Canadian. In the past not only has America swept the record breaking board, but her athletes have also emphasized their superiority at every celebration of the Olympic Games.

The cycle of national success is extraordinarily interesting. First, Great Britain, in which I include the Irish throwing-men, was unbeatable ; but when America settled down seriously to produce athletes and imported Irish coaches and athletes she rapidly overhauled and soon surpassed the older land, until the complete conquest of the London Athletic Club by the New York A.C. in America in 1895 proved conclusively that the power had passed across the Atlantic. In the following year the first celebration of the revived Olympic Games was held, and since then America has never been conquered upon the athletic field.

The United States has enjoyed a wonderful run, but there are signs that a period is about to be put to her supremacy. The Continental and Scandinavian peoples have made wonderful progress ; the Far Eastern countries and the Latin races, both in Europe and South America, show promise, which is proved statistically by the percentage improvement which is to be found in the average of performance of the first ten men in each event per year per nation.

In the first place progress is undoubtedly due to the fact that all nations, except Great Britain, employ as well-paid professional coaches men of good social and mental status. There is also the question of grounds. Great Britain is very badly served in this respect. Now that Queen's Club is to be devoted exclusively to the practice of lawn tennis, there are only two grounds in England which are really worthy to be called athletic stadia—the Weetwood Ground, which has recently been laid out by Leeds University, and the Army Athletic Ground at Aldershot. At Stamford Bridge, the home of the English Championships, the track has been ruined by dirt track racing, and the hurdles course on grass

Some Points in Athletic Science 345

does not compare favourably with the smoothness of many a secondary school field. In America there are wonderful indoor tracks; the outdoor cinder paths are the fastest in the world, with the possible exception of the Olympic stadium at Stockholm; and, moreover, the Americans are so well catered for that, when the weather makes the ground sodden, board tracks, run-ways, and jumping fans are put down, in order that the athletes may continue practising. (See Plate 62.) The late James Sullivan sought to explain America's greatness on the grounds that the national game of baseball engenders all the qualities an athlete needs. But that does not explain the phenomenon, for the combination of British games—cricket, football under both codes, and hockey—must be at least as good, while the Scandinavians had produced world-beaters in athletics before ever they took seriously to team games.

In any case we must be dealing in inverse ratio when we talk of building athletic efficiency upon any team game, since the natural actions of running, jumping, and throwing must provide the fundamental basis of all other forms of sport. The real explanation is that America's first-class professional coaches hit upon an elementary sequence principle that the science of understanding things is, first, observation, and secondly, noting the relation existing between one thing and another. Hence their excellent system of teaching has been evolved. The early pioneers of scientific instruction studied "effect," they had a dim comprehension of "cause," but they did not envisage the third factor, which is the proof of the connection between any two, or more, actions by quantitative measurement.

Paavo Nurmi, Finland, revolutionised modern distance running by setting himself to maintain an even pace throughout his races. One wonders why, and how, he hit upon this principle? That it is a correct one can, of course, be proved scientifically, while Professor Kennelly, of Boston, U.S.A., has suggested that more than one distance running record might be broken with the aid of a mechanical pacemaker, travelling at a constant speed and so adjusted that the runner, by keeping up

with it, would just break the existing record. The time may well come, in America at all events, and probably in Germany, when we shall find training tracks fitted with electric wires, along which will travel little figures which may be set to go at any constant speed, so that runners will be trained to produce a constantly increasing even pace, until each man's personal "optimum" is discovered. Something on the lines of the electric hare, will no doubt eventuate in time.

This suggestion is based upon the undoubted fact that the breaking of distance records depends upon the ability of the athlete to discover his best constant speed for a particular distance. In a 5 mins. mile, for example, it would be 352 yards per minute. If Paavo Nurmi or A. G. Hill, when they broke, respectively, world's and British mile records, had achieved the time of 4 mins. 8 secs. at which they aimed, in planning to run each quarter-mile lap in 62 secs., a constant speed of just over 425 yards per minute would have been required. The speed, of course, must be adjusted to the distance, just as the motorist changes his gears to suit the various gradients he encounters on the roads.

Throughout this book the athlete has been recommended to make jog-trot running a part of his training, even for such events as the sprints. There is a scientific reason for this suggestion, and it is related to the preservation of an even pace. It is that a man "shaking," or jogging, half a mile very slowly at a recommended speed uses but little oxygen, or, in other words, has a "low fuel consumption," in the conditioning of his body and limbs. I think too that jogging is more economical in this respect than walking. The amount of oxygen used in walking a mile in an hour is the same as that required for sprinting 100 yards in 10 secs. But there are two other matters upon which a deal of emphasis has been laid. These are the necessity of limbering up before action and of keeping the body warm during wait periods in competition. These two matters are intimately connected with each other.

All athletes know, and many fear, the feeling of nervous excitement that precedes a race. In point of fact the man who

Some Points in Athletic Science 347

does not "get the needle" is very rarely successful in any event calling for the sudden production of a high horse-power. I have in mind such events as the sprints and hurdle races. This excitement is really nature's method of preparing the athlete for the coming struggle. In every man's body, deep buried near the kidneys, are the suprarenal glands; these glands, during emotion, produce adrenalin, which enters the blood stream and strengthens and quickens the heart beat. This organ is further aided in its work by a rise in body temperature. Wise coaches have understood something of this, and I well remember the careful use the late S. A. Mussabini made of his thermometer before sending a highly strung subject, such as H. F. V. Edward, out to run a race.

Mention has been made of Nurmi jogging as far as two miles to limber up for a five miles race. Why did he do it? I think the answer is to be found in the fact that the athlete at the beginning of exercise does not reach his full rate of oxygen consumption for two or three minutes. This means that, without limbering up, he would be working well under power for that period of time. One finds an analogy in the case of the motor-car, which does not "pull" well for some distance if one starts driving as soon as the engine picks up. That is why chauffeurs run their engines for some time on a cold morning before they seek to engage the gears. There must therefore be a certain expenditure of energy in limbering up* before competition, if the heart, lungs and muscles, through oxidation, are to work at full power right away, when the effort is required of them. There are other and even more important reasons both for limbering up and for the maintenance of warmth.

I suppose every one knows that the custom of starting races by dropping a handkerchief was abandoned in favour of a pistol start because man reacts more quickly to sound than to sight. It is known also that the sprinter loses a considerable time in the starting process. Much of this loss is due to slow reaction. Men make better times up to 440 yards in the warm, oxygen-laden atmosphere of California and South Africa than in Europe. But why? The higher oxygen value has some-

thing to do with it, of course, but I fancy the warmth is far more important. Even cold-blooded creatures, like frogs and tortoises, move faster in hot tropical sunshine, while the latter move hardly at all in a European winter. It amounts to this—that everything in the human machine—like the motor engine—goes on more rapidly when that machine is warm. Most important of all, when the body temperature is raised the muscles send their "news" more rapidly to the nervous system, and receive back their orders by "express" return. The nerve impulses in a man at 37 degrees Centigrade pass as quickly as 400 ft. per second. Obviously, therefore, the man who raises his body temperature by limbering up in warm clothing, such as Paavo Nurmi is wearing in Picture No. 1, Plate II, must be better able to respond quickly to the starter's gun signal or to his own orders to throw or jump, than is another man whose body is cold; for the latter has not the advantage of full oxidation of the lungs, heart, and muscles, nor is his personal "telephone exchange" working at the highest attainable speed.

Any coach will tell you that it is necessary to resume your sweater and track trousers between heats of races, or while awaiting your next turn to throw or jump. The Finns go even further than this. Not only do they limber up before a contest in the sort of sweat suit that Nurmi wears and put it on again after each jump or throw, but I have remarked repeatedly that, when a heat in a running contest is over, the track suit is put on again, the man goes back to the dressing-room, gets on to the rubbing-table, and has his limbs massaged through his sweat suit. The reason for this is that the Finns understand that the body had reached its highest efficiency at the finishing temperature in the heat just run and strive therefore to have the subject's body as nearly as possible at the same temperature when he goes out to run in the ensuing heat or final.

If you ask a trainer why massage and warmth are so necessary he will tell you it is to prevent your muscles from becoming chilled and stiff; but no scientist has yet, to the best of my knowledge, discovered what stiffness really is. We know that

certain waste products of exhaustion are deposited in the muscle substance through violent exercise, and that massage directs them back into the blood stream and so relieves the muscles ; but it is a change, through exertion, in the fuel that stokes the human engine that is really involved. As yet, we have not discovered the properties of all the chemical substances that cause muscular contraction, and so enable us to perform feats of skill and strength. But we do know that muscles are made of protein, containing carbon, hydrogen, nitrogen, and oxygen, among other things, and that they have as their fuel a starch-like substance, named glycogen, which is turned readily into sugar. Without this glycogen we should not be able to move at all, for it is what we use in doing our physical work. But when this substance is used it is not done with, since it is built up again from the sugar which comes to the muscle fibres through the blood, which in its turn collects the required sugar either from the reserve store in the liver, or from the intestines which absorb it in the digestion of food.

Fatigue is probably caused by the increase in the muscle substance, by its own action, of lactic acid. The amount of such acid liberated corresponds with the amount of work done and may be as much as one ounce in the case of a sprinter working at top speed ; but it may be, and is, removed by increasing the supply of oxygen. Another neutralizing agent is the reserve of alkali, which is stored in the muscle substance for this particular purpose. It has indeed been suggested that the special facility for greater neutralization of acid in the muscles is the quality that distinguishes the great athlete from more ordinary men.

The recovery process after exertion is curiously interesting, for, although the lactic acid disappears, it is found again in its original form as glycogen. The glycogen has created energy plus lactic acid in the work phase, while in the rest period of recovery the lactic acid passes back into glycogen minus energy through the introduction of oxygen and the help of the muscle alkali. We have seen already that everything goes on more

quickly in the human machine when the temperature is raised. This applies especially to the process of recovery, which is greatly expedited by the warmth preservation process practised by the Finns.

Both the duration of an effort and the length of time necessary to recover from it depend upon its nature and the personal oxygen income and oxygen borrowing power of the individual. The sprinter has next to nothing in the way of oxygen income during his dash from gun-fire to finishing tape, and therefore creates a large oxygen debt, which must be paid off in the process of recovery. It is this consideration of income and credit which cuts down the sprint distance to not more than 300 yards. The distance runner, on the other hand, breathes regularly as he runs and therefore lives on his income as well as having his oxygen credit to draw upon.

The time necessary for recovery should be understood, not only by athletes, but also by those who draw up sports programmes. The athlete must be allowed sufficient time to eliminate all the lactic acid, otherwise fatigue will recur before he can complete his fresh effort, and, although one cannot say exactly what functions are performed, or changes effected, by the process of training, we do know that the trained athlete uses far less oxygen than the untrained man, and that he has a quicker recovery constant after exertion than a man who leads a sedentary life. After a violent effort, lasting under a minute, almost full recovery takes place in less than ten minutes, but the safety margin suggests that the sprinter should be allowed at least twenty minutes' rest between one race and the next.

It may well be asked how Nurmi ran that marvellous 10,000 metres cross-country race in tropical heat at Paris in 1924 and yet finished unfatigued, while other men lay at death's door from over-exertion. Or why Arthur Newton, having broken the London to Brighton running record, could light his pipe and stroll away completely unconcerned at the end of it. The answer is that both these great runners had solved the secret of running out of income. In other words, their powers

Some Points in Athletic Science 351

of recuperation kept pace with the break-down processes, which are inseparable from exertion.

In the course of this book reference has been made to the fuel that drives the human engine. We have learned that sugar is probably the basic principle of this fuel, but this does not mean that we must eat sugar and nothing else. Natural processes will break down other materials into sugar; and fat, per unit of weight, contains twice as much energy as any other food. And, since I was in Scandinavia and saw the vast quantities of milk, butter, and oil consumed by the people of the four countries, I have often wondered how far this particular part of their diet accounts for their wonderful physical efficiency. We know that certain foods which will generate heat are good, and we know that the blood must be kept pure, or it will not perform properly its functions of carrying off carbonic acid, which it should take to the lungs whence we breathe it out.

I have admitted already that neither I, nor any man, can tell you just what happens to the body in training, which enables the trained athlete to make demands upon his system, such as would be preposterous without a proper preparation. We see the effect, but we do not know the cause. The muscles are stronger, they are better supplied with their fuel—glycogen—and they work more economically, but why they do so we cannot say. The fact that they do conserve their energy despite increased activity gives us just a hint to be followed, and that leads us straightaway to an altogether different aspect of training. A good coach will set his pupil certain tasks to perform, because he knows that by such means a definite object will be attained. But there must be made, in the first instance, many experiments with different "styles," or types of action, and there must be also close observation of which actions are successful, or otherwise, so that the ideal form may ultimately be evolved.

The fact that the coach possesses, and can impart, abounding knowledge is not in itself sufficient. The pupil has to memorise the movements in order that he may repeat them. But can one memorise thousands of messages sent at incredible speed

from the nervous system to the muscles? Can one even make a mental cinematograph of one's own movements? I dare say we do so in remembering the style displayed by another athlete, but in our own case I am sure that we can neither visualise nor memorise a series of intricate movements taking place at speeds of thousandths of a second.

A man does not remember what he has learned, or even done, in training, but rather recollects the sensations he has experienced. If this were not so, then a man learning the art of shot putting from a book should prove himself straightaway a first class performer, provided his strength were equal to the task. As it is, the sequence of sensations correspond to a muscular and nervous system sensory cinematograph of the whole evolution practised.

Athletic skill depends upon the co-operation of the muscles, nerves and nervous system, plus the ability to assume certain postures and to perform certain actions in the most economical manner. The importance of nerve training is further proved by the fact that we have only one means of making a muscle do more work. That is by sending it its instructions to increase its activity along a larger number of nerve fibres, so that more muscle fibres may take part in the required activity. The necessities and dangers of everyday life cause us to perform certain acts for our self-preservation quite unconsciously; and in the same way, the athlete can, by training his nervous system, acquire an almost equal facility for performing any required athletic evolution automatically. He can, moreover, aid his progress a lot by just thinking sensibly and consecutively about his event and by educating his nervous system and muscles.

Why does the hunting man, when he takes a toss, roll to save his neck and limbs? He is not in the habit of falling, and so the act of self-preservation is seldom called for. He would not admit such to be the case, but I fancy that he acts as he does because he has often *thought* of falling and has thereby trained himself to perform the necessary action of rolling.

The power of conditioned reflex action can also be produced

by careful education. Professor Pavlov, a great Russian physiologist, proved this by an experiment with a dog. In this case the stimulus for the conditioned reflex was supplied by teaching the dog to expect food when he heard the sound of a tuning fork vibrating 100 times per second. On hearing this, the animal's mouth would water, but the sound of a tuning fork vibrating at any other speed did not produce salivation. Man, by similar educational means, can be trained to produce a "competition condition of mind" in certain given circumstances. This indicates that the whole of his training should be done in competition conditions, and as nearly as possible each day at the hour at which the contest for which he is preparing will probably take place.

We come now to the question of balance and body posture. The adjustment of balance has much to do with the semi-circular canals, three to each ear, which tell us about the rotation of the body. Every one is familiar with the expression "getting his sea-legs." This is merely a matter of becoming accustomed to a constant adjustment of balance, required more frequently than it would be if we were on dry land. It is the same thing with hammer and discus throwers who are called upon to practise a fast rotary movement which does not form a part of a man's normal everyday life, but to which he will become accustomed in training.

The jumping, throwing, and pole vault events are made up of a number of quickly changing postures, each of which is maintained by a tonic contraction of the muscles, but the tone must harmonize with the voluntary and reflex contractions. Everything that one does in executing a field event evolution has, or should have, a definite purpose. Therefore, every voluntary action must be made to suit the position it is desired to assume. If there is only one possible response to a certain reflex action, that action will take place very quickly. Therefore, if the position the athlete has assumed is such that the logical ensuing action is suggested, that action will take place more quickly and with a better result than if a wrong preliminary posture has been reached. Take, for example, the tangential departure

from a circle in discus throwing. If the feet are wrongly disposed at the end of the turning movement a delivery to the right is indicated and a further *conscious* effort will be required of the thrower if he is to make the delivery properly in front of the body ; *ergo*—study pictures, work at style, and learn the foot-work.

Throwing men in particular must take care to relate their events. Some muscles are antagonistic to others. For example, the muscles that bend the arms are in opposition to those that extend it, so that when one set is flexed the other is relaxed. For this reason the hammer thrower very seldom excels also as a shot putter and *vice versa*.

By careful experiment, by deep thought and by constantly seeking after first causes, we can learn a great deal about ourselves and can turn that knowledge to full account in the improvement of our athletic ability. But one can also learn a lot from nature. One never knows where this sort of seeking after knowledge is going to lead. The study of the conduction of gases through electricity led to the discovery of X-rays. It was the work of physiologists in studying the heart beat that, adapted to the particular requirements, led to the location of gun positions during the war, while the discovery of the "Western Roll" method of high jumping was equally fortuitous. We cannot hope to acquire the jumping power of a flea or the fleetness of an antelope ; but all life had probably a single source and did not start separately in a hundred different ways. It is reasonable to assume, therefore, that there must still be much which the athlete could learn from the observation of wild animals to his great advantage.

Just one instance of this has come recently to my notice through the study of a film which was taken to show how a cat, dropped back-downwards, will turn in mid-air so that it may alight upon its feet. The point of interest to athletes which this motion picture revealed is that the cat, in the moment of completing its turning movement, arches its body in exactly the same way as does the expert pole vaulter when he clears the crossbar.

Some Points in Athletic Science 355

The study of action photographs must be very carefully undertaken, for the special reason that press photographers have an unfortunate fondness for placing the camera in a position when taking the photograph which will make it appear that the athlete is jumping a great deal higher than is in reality the case. But action pictures taken on a level with the centre of gravity of the performer are really instructive. It is to the cinematograph, however, and particularly to pictures taken at high speeds and projected slowly, so that each action can be carefully studied, that we must turn for our "dumb instructor" in the final issue.

The reader, no doubt, will find many points in this chapter that are instructive, but I admit frankly that it is written in a provocative spirit, in the hope that it may stimulate in the minds of many sportsmen a keener interest in the scientific side of the particular event they practise.

APPENDIX

WORLD'S RECORDS

Accepted by the I.A.A.F. Congress at Amsterdam, August 7th 1928.

Event	Time or Distance	Holder	Yr.	Event	Time or Distance	Holder	Yr.
		RUNNING				HURDLES—cont'd.	
		D. J. Kelly U.S.A.	1906	110 met.	14.6	G. C. Weightman-Smith, South Africa	1928
		H. P. Drew, U.S.A.	1914	200 "	23	Ch. Brookins, U.S.A.	1924
*100yds.	9.6	Ch. W. Paddock, U.S.A.	1921	400 "	52	F. M. Taylor, U.S.A.	1928
		C. H. Coaftee, Canada	1922				
		Ch. W. Paddock, U.S.A.	1924				
			1926				
		Ch. Bowman, U.S.A.	1927	1 ml.	6 25.8	G. H. Goulding, Canada	1910
220 "	20.6	R. A. Locke, U.S.A.	1926	2 mls.	13 11.4	G. E. Larnar, Gt. Brit.	1904
300 "	30.6	B. J. Wefers, U.S.A.	1896	3 "	20 25.8	" " " " " " " " " "	1905
440 "	47.4	J. E. Meredith, U.S.A.	1916	4 "	27 14	" " " " " " " " " "	1905
600 "	1 10.4	D. G. A. Lowe, Gt. Brit.	1926	5 "	36 0.2	" " " " " " " " " "	1905
880 "	1 51.6	Dr. O. Peltzer, Germany	1926	6 "	43 26.2	" " " " " " " " " "	1905
1,000 "	2 12.2	L. Brown, U.S.A.	1921	7 "	50 40.8	G. H. Goulding (Canada)	1915
1,320 "	3 2.8	T. P. Connett, U.S.A.	1895	8 "	58 18.4	G. E. Larnar, Gt. Brit.	1905
1 mile	4 10.4	Paavo Nurmi, Finland	1923	9 "	1 7 37.8	" " " " " " " " " "	1908
2 mls.	9 10.4	E. Wide, Sweden	1926	10 "	1 15 57.4	" " " " " " " " " "	1908
3 "	14 11.2	Paavo Nurmi, Finland	1923	15 "	1 59 12.6	H. V. L. Ross, Gt. Brit.	1911
4 "	19 15.6	" " " " " " " " " "	1924	20 "	2 47 52	T. Griffith, Gt. Brit.	1870
5 "	24 6.2	" " " " " " " " " "	1924	25 "	3 37 6.8	S. C. A. Schofield, Gt. Brit.	1911
6 "	29 59.4	A. Shrubbs, Gt. Brit.	1904	3,000 met.	12 53.8	G. Rasmussen, Denmark	1918
7 "	35 4.6	" " " " " " " " " "	"	5,000 "	21 59.8	" " " " " " " " " "	1918
8 "	40 16	" " " " " " " " " "	"	10,000 "	45 26.4	" " " " " " " " " "	1918
9 "	45 27.6	" " " " " " " " " "	"	15,000 "	1 10 23	" " " " " " " " " "	1918
10 "	50 40.6	" " " " " " " " " "	"	20,000 "	1 37 42.2	D. Pavesi, Italy	1927
15 "	1 20 4.4	F. Appleby, Gt. Brit.	1902	25,000 "	2 50 12.2	A. Schwab, Switzerland	1927
20 "	1 51 54	G. Crossland, Gt. Brit.	1894	1 hr.—8 mls.	438 yds.	" " " " " " " " " "	
25 "	2 29 29.4	H. Green, Gt. Brit.	1913	2hrs.—15 mls.	128 yds.	G. E. Larnar, Gt. Brit.	1905
100 met.	10.4	Ch. Paddock, U.S.A.	1921	(24,256 met.)		H. V. L. Ross, Gt. Brit.	1911
200 "	20.6	R. A. Locke, U.S.A.	1926				
300 "	33	Ch. W. Paddock, U.S.A.	1921	Standing High Jump—		JUMPING	
400 "	47.4	J. E. Meredith, U.S.A.	1916	5ft 5 1/2 in. = 167cm.		L. Goehring, U.S.A.	1913
500 "	1 3.6	Dr. O. Peltzer, Germany	1926	Running High Jump—			
800 "	1 50.6	S. Martin, France	1928	6ft. 8 1/2 in. = 203cm.		H. M. Osborn, U.S.A.	1924
1,000 "	2 25.8	Dr. O. Peltzer, Germany	1927	Standing Broad Jump—			
1,500 "	3 51	" " " " " " " " " "	1926	11ft. 4 1/2 in. = 347cm.		R. C. Ewry, U.S.A.	1904
2,000 "	5 23.4	E. Borg (Purje), Finland	1927	Running Broad Jump—		De Hart Hubbard, U.S.A.	1925
3,000 "	8 20.4	Paavo Nurmi, Finland	1926	25ft. 10 1/2 in. = 789cm.			
5,000 "	14 28.2	" " " " " " " " " "	1924	Running Hop, Step & Jump			
10,000 "	30 6.2	" " " " " " " " " "	1924	50ft. 1 1/2 in. = 15.325 met.		A. W. Winter, Aust.	1924
15,000 "	47 18.6	J. Bouin, France	1913	Pole Vault—14ft = 426cm.		S. W. Carr, U.S.A.	1927
20,000 "	1 6 29	V. Sipilä, Finland	1925	Best hand—		SHOT	
25,000 "	1 25 20	H. Kolehmainen, Finland	1922	52ft. 0 1/2 in. = 15.87 met.		J. Kuck, U.S.A.	1928
30,000 "	1 46 11.6	A. Stenroos, Finland	1924	Both hands—			
11 hr.—19,021 met. 90 cm. (11 miles 1,442 yds.)		J. Bouin, France	1913	91ft. 10 1/2 in = 28met.		R. Rose, U.S.A.	1912
2 hrs.—20 miles 952 yds. (33,056 met.)		H. Green, Gt. Britain	1913	(right hand 50ft. 6in. = 15.39 met; left hand 41ft. 4 1/2 in. = 12.61 met.)			
		RELAY RACES		Best hand—		DISCUS	
4x110yds.	41	Newark A.C., U.S.A.	1927	158ft. 1 1/2 in. = 48.20 met.		C. L. Houser, U.S.A.	1926
4x220 "	1 25.8	University of So. California, U.S.A.	1927	Both hands—			
4x440 "	3 18	University of Pennsylvania, U.S.A.	1915	295ft. 8 1/2 in. = 90.13 met.		E. Niklander, Finl'd	1913
4x880 "	7 41.4	Boston A.A., U.S.A.	1926	(right hand 45.57 met. = 149ft. 6in.; left hand 44.56 met. = 146ft. 2 1/2 in.)			
4x1 mile	17 21.4	Illinois A.C., U.S.A.	1923				
		(Olympic team, U.S.A.)	1924				
4x100 met	41	Newark A.C., U.S.A.	1927	Best hand—		JAVELIN	
		Sp. G. Eintracht, Frankfurt, Germany	1928	229ft. 3 1/2 in. = 69.88 met.		E. Penttilä, Finland	1927
4x200 "	1 25.8	Univ. of So. California, U.S.A.	1927	Both hands—			
4x400 "	3 14.2	Olympic team, U.S.A.	1928	374ft. 1 1/2 in. = 114.28met.		Y. Häckner, Sweden	1917
4x800 "	7 41.4	Boston A.A., U.S.A.	1926				
4x1,500 "	16 11.4	Turun Urheilullitto, Abo., Finland	1926				
		HURDLES				56lb. WEIGHT	
120 yds.	14.4	E. J. Thomson, Canada	1920			M. McGrath, U.S.A.	1911
220 "	22	Ch. Brookins, U.S.A.	1924				
440 "	52.6	J. A. Gibson, U.S.A.	1927				
						DECA TELON	
				8053.29 pts.		J. Yrjölä, Finland	1928

* On 30th March, 1929, at Dallas, Texas, C. Bracey, U.S.A., was credited with 9 2/3 secs.
 † On 7th October, 1928, at Berlin, P. Nurmi, Finland, ran 11 miles 1,636 yards in 1 hour.

Appendix

357

OLYMPIC TRACK AND FIELD CHAMPIONS, 1896-1928

Dates and Places of Olympic Celebrations; 1896, ATHENS. 1900, PARIS. 1904, ST. LOUIS. 1906, ATHENS (Intercalated Series). 1908, LONDON. 1912, STOCKHOLM. 1920, ANTWERP. 1924, PARIS. 1928, AMSTERDAM.

Yr.	Winners	Time or Distance	Yr.	Winners	Time or Distance
60 METRES RUN 1900 A. E. Kraenzlein, U.S.A. 7 1904 A. Hahn, U.S.A. 7			10,000 METRES RUN (10,936 yards) 1912 H. Kolehmainen, Finland ms. secs. 31 20 4/5 1920 P. Nurmi, Finland 31 45 4/5 1924 V. Ritola, Finland 30 23 1/5 1928 P. Nurmi, Finland 30 18 4/5		
100 METRES RUN (109 yards 1 ft. 1 1/32 ins.) 1896 T. E. Burke, U.S.A. 12 1900 F. W. Jarvis, U.S.A. 104/5 1904 A. Hahn, U.S.A. 11 1906 A. Hahn, U.S.A. 11 1/5 1908 R. E. Walker, S. Africa 10 4/5 1912 R. C. Craig, U.S.A. 10 4/5 1920 C. W. Paddock, U.S.A. 10 4/5 1924 H. M. Abrahams, Great Britain 10 3/5 1928 P. Williams, Canada 10 4/5			MARATHON 1896 S. Loues, Greece h. m. secs. 2 55 20 1900 Teato, France 2 59 0 1904 T. J. Hicks, U.S.A. 3 28 53 1906 W. J. Sherring, Canada 2 51 23 3/5 1908 J. J. Hayes, U.S.A. 2 55 18 1912 K. K. McArthur, S. Africa 2 36 54 4/5 1920 H. Kolehmainen, Finland 2 32 35 4/5 1924 A. O. Stenroos, Finland 2 41 22 3/5 1928 El Ouah, France 2 32 57		
200 METRES RUN (218 yards 2 ft. 2 ins.) 1900 J. W. B. Tewksbury, U.S.A. 22 1/5 1904 A. Hahn, U.S.A. 21 3/5 1908 R. Kerr, Canada 22 2/5 1912 R. C. Craig, U.S.A. 21 7/10 1920 A. Woodring, U.S.A. 22 1924 J. V. Scholz, U.S.A. 21 3/5 1928 P. Williams, Canada 21 4/5			110 METRES HURDLES (120 yards 0 ft. 107/10 ins.) 1896 T. P. Curtis, U.S.A. secs. 17 3/5 1900 A. C. Kraenzlein, U.S.A. 15 2/5 1904 F. W. Schule, U.S.A. 16 1906 R. G. Leavitt, U.S.A. 16 1/5 1908 Forrest Smithson, U.S.A. 15 1912 F. W. Kelly, U.S.A. 15 1/10 1920 E. J. Thomson, Canada 14 4/5 1924 D. C. Kinsey, U.S.A. 15 1928 S. J. M. Atkinson, S. Africa 14 4/5		
400 METRES RUN (437 yards 1 ft. 4 1/8 ins.) 1896 T. E. Burke, U.S.A. 54 1/5 1900 M. W. Long, U.S.A. 49 2/5 1904 H. L. Hillman, U.S.A. 49 1/5 1906 P. Pilgrim, U.S.A. 53 1/5 1908 W. Halswelle, Great Britain (w.o.) 50 1912 C. D. Reidpath, U.S.A. 48 1/5 1920 B. G. D. Rudd, S. Africa 49 3/5 1924 E. H. Liddell, Great Britain 47 3/5 1928 R. Barbuti, U.S.A. 47 4/5			200 METRES HURDLES (218 yards 2 ft. 2 ins.) 1900 A. C. Kraenzlein, U.S.A. secs. 25 2/5 1904 H. L. Hillman, U.S.A. 24 3/5		
800 METRES RUN (874 yards 2 ft. 8 1/2 ins.) 1896 E. H. Flack, Great Britain ms. secs. 2 11 1900 A. E. Tysoe, Great Britain 2 1 2/5 1904 J. D. Lightbody, U.S.A. 1 56 1906 P. Pilgrim, U.S.A. 2 1 1/5 1908 M. W. Sheppard, U.S.A. 1 52 4/5 1912 J. E. Meredith, U.S.A. 1 51 9/10 1920 A. G. Hill, Great Britain 1 53 2/5 1924 D. G. A. Lowe, Great Britain 1 52 2/5 1928 D. G. A. Lowe, Great Britain 1 51 4/5			400 METRES HURDLES (437 yards 1 ft. 4 1/8 ins.) 1900 J. W. B. Tewksbury, U.S.A. secs. 57 3/5 1904 H. L. Hillman, U.S.A. 53 1908 C. J. Bacon, U.S.A. 55 1920 F. F. Loomis, U.S.A. 54 1924 F. M. Taylor, U.S.A. (Record not allowed) 52 3/5 1928 Lord Burghley, Great Britain 53 2/5		
1,500 METRES RUN (1,640 yards 1 ft.) 1896 E. H. Flack, Great Britain ms. secs. 4 33 1/5 1900 C. Bennett, Great Britain 4 6 1904 J. D. Lightbody, U.S.A. 4 5 2/5 1906 J. D. Lightbody, U.S.A. 4 12 1908 M. W. Sheppard, U.S.A. 4 3 2/5 1912 A. N. S. Jackson, Great Britain 3 56 4/5 1920 A. G. Hill, Great Britain 4 1 4/5 1924 P. Nurmi, Finland 3 53 3/5 1928 H. E. Larva, Finland 3 53 1/5			2,500 METRES STEEPLECHASE 1900 G. W. Orton, U.S.A. ms. secs. 7 34 1904 J. D. Lightbody, U.S.A. 7 39 3/5		
5,000 METRES RUN (3 miles 188 yards) 1912 H. Kolehmainen, Finland ms. secs. 14 36 3/5 1920 J. Guillemot, France 14 55 3/5 1924 P. Nurmi, Finland 14 31 1/5 1928 V. Ritola, Finland 14 38			3,000 METRES STEEPLECHASE (1 mile 1,520 yards 2 ft.) 1920 P. Hodge, Great Britain ms. secs. 10 2 2/5 1924 V. Ritola, Finland 9 33 3/5 1928 T. A. Loukola, Finland 9 21 4/5		
5 MILE RUN 1906 H. Hawtrey, Great Britain ms. secs. 26 26 1/5 1908 E. R. Voigt, Great Britain 25 11 1/5			3,200 METRES STEEPLECHASE 1908 A. Russell, Great Britain ms. secs. 10 47 4/5		
			4,000 METRES STEEPLECHASE 1900 C. Rummer, Great Britain ms. secs. 12 58 2/5		
			CROSS-COUNTRY 1912 H. Kolehmainen, Finland ms. secs. 45 11 3/5		
			10,000 METRES CROSS-COUNTRY (10,936 yards) 1920 P. Nurmi, Finland ms. secs. 27 15 1924 P. Nurmi, Finland 32 54 4/5		
			1,500 METRES WALK 1906 G. V. Bonhag, U.S.A. ms. secs. 7 12 3/5		

OLYMPIC CHAMPIONS—continued.

Yr.	Winners	Time or Distance	Yr.	Winners	Time or Distance
	3,000 METRES WALK	ms. secs.		STANDING HOP, STEP & JUMP	ft. ins.
1920	U. Frigerio, Italy	13 14 1/5	1900	R. C. Ewry, U.S.A.	34 8 1/2
	3,500 METRES WALK	ms. secs.	1904	R. C. Ewry U.S.A.	34 7 1/4
1908	G. E. Larner, Great Britain .. .	14 55		RUNNING HOP STEP & JUMP	ft. ins.
	10,000 METRES WALK	ms. secs.	1896	J. B. Connolly, U.S.A.	45 0
	(10,936 yards)		1900	Myer Prinstein U.S.A.	47 4 1/4
1912	G. H. Goulding, Canada	46 28 2/5	1904	Myer Prinstein, U.S.A.	47 0
1920	U. Frigerio, Italy	48 6 1/5	1906	P. O'Connor, Ireland	46 2
1924	U. Frigerio, Italy	47 49	1908	T. J. Ahearne, Great Britain .. .	48 11 1/4
	10 MILE WALK	h. m. secs.	1912	G. Lindblom Sweden	48 5
1908	G. E. Larner, Great Britain .. .	1 15 57	1920	V. Tuulos, Finland	47 7 1/8
	400 METRES RELAY	secs.	1924	A. W. Winter, Australia	50 11 1/2
	(437 yards 1 ft. 4 1/8 ins.)		1928	M. Oda, Japan	49 10 1/2
1912	Great Britain	42 2/5		16 LB. SHOT PUT	ft. ins.
1920	United States	42 1/5	1896	R. S. Garrett, U.S.A.	36 2
1924	United States	41	1900	R. Sheldon, U.S.A.	46 3 1/8
1928	United States	41	1904	R. Rose, U.S.A.	48 7
	1,600 METRES RELAY	ms. secs.	1906	M. J. Sheridan, U.S.A.	40 4 1/5
	(1,749 yards 2 ft. 4 ins.)		1908	R. Rose, U.S.A.	46 7 1/2
1908	United States	3 27 1/5	1912	P. J. McDonald, U.S.A.	50 3 9/10
1912	United States	3 16 3/5		(Right and Left Hand—R. Rose, U.S.A., 90 ft. 5 2/5 ins.)	
1920	Great Britain	3 22 1/5	1920	V. Porhola, Finland	48 7 1/8
1924	United States	3 16	1924	C. Houser, U.S.A.	49 2 3/8
1928	United States	3 14 1/5	1928	J. Kuck, U.S.A.	52 0 1/2
	POLE VAULT	ft. ins.		16 LB. HAMMER THROW	ft. ins.
1896	W. W. Hoyt, U.S.A.	10 9 3/4	1900	J. J. Flanagan, U.S.A.	167 4
1900	I. K. Baxter, U.S.A.	10 9 9/10	1904	J. J. Flanagan, U.S.A.	168 1
1904	C. E. Dvorak, U.S.A.	11 6	1908	J. J. Flanagan, U.S.A.	170 4 1/4
1906	F. Gonder, France	11 6	1912	M. J. McGrath, U.S.A.	179 7 9/16
1908	A. C. Gilbert, U.S.A. } E. T. Cook, Jr. U.S.A. }	12 2	1920	P. J. Ryan, U.S.A.	173 5 1/8
1912	H. J. Babcock, U.S.A. }	12 11 1/2	1924	F. D. Tootell, U.S.A.	174 10
1920	F. K. Foss, U.S.A.	13 5	1928	P. O'Callaghan, Ireland	168 7 3/8
1924	L. S. Barnes, U.S.A. } Glenn Graham, U.S.A. }	12 11 1/8		56 LB. WEIGHT	ft. ins.
1928	S. W. Carr, U.S.A.	13 9 1/2	1904	E. Desmarteau, Canada	34 4
	STANDING HIGH JUMP	ft. ins.	1920	P. J. McDonald, U.S.A.	36 11 1/2
1900	R. C. Ewry, U.S.A.	5 5		DISCUS THROW	ft. ins.
1904	R. C. Ewry, U.S.A.	4 11	1896	R. S. Garrett, U.S.A.	95 7 1/2
1906	R. C. Ewry, U.S.A.	5 1 5/8	1900	Bauer, Hungary	118 2 9/10
1908	R. C. Ewry, U.S.A.	5 2	1904	M. J. Sheridan, U.S.A.	128 10 1/2
1912	Platt Adams, U.S.A.	5 4 1/5	1906	M. J. Sheridan, U.S.A.	136 0 1/5
	RUNNING HIGH JUMP	ft. ins.	1908	M. J. Sheridan, U.S.A.	134 2
1896	E. H. Clark, U.S.A.	5 11 1/4	1912	A. R. Taipale, Finland	148 3 9/10
1900	I. K. Baxter U.S.A.	6 2 4/5		Right and Left Hand—A. R. Taipale	271 10 1/5
1904	S. Jones, U.S.A.	5 11	1920	E. Niklander, Finland	146 7 3/10
1906	C. Leahy, Ireland	5 9 7/8	1924	C. Houser, U.S.A.	151 5 1/2
1908	F. H. Porter, U.S.A.	6 3	1928	C. Houser, U.S.A.	155 2 1/2
1912	A. W. Richards, U.S.A.	6 4		DISCUS THROW—GREEK STYLE	
1920	R. W. Landon, U.S.A.	6 4 1/5	1906	V. Jaervinen, Finland	115 4
1924	H. M. Osborn, U.S.A.	6 6	1908	M. J. Sheridan, U.S.A.	124 8
1928	R. King, U.S.A.	6 4 3/8		JAVELIN THROW	ft. ins.
	STANDING BROAD JUMP	ft. ins.	1906	E. Lemming, Sweden	175 6
1900	R. C. Ewry, U.S.A.	10 6 2/5	1908	E. Lemming, Sweden	178 7 1/2
1904	R. C. Ewry, U.S.A.	11 4 7/8		Held in middle—E. Lemming, Sweden	179 10 1/2
1906	R. C. Ewry, U.S.A.	10 10	1912	E. Lemming, Sweden	198 11 3/8
1908	R. C. Ewry, U.S.A.	10 11 1/4		Right and Left Hand—J. J. Saaristo, Finland	358 11 9/10
1912	C. Ticilitiras, Greece	11 0 1/4	1920	J. Myyry, Finland	215 9 3/4
	RUNNING BROAD JUMP	ft. ins.	1924	J. Myyry, Finland	206 6 1/2
1896	E. H. Clark, U.S.A.	20 9 3/4	1928	E. H. Lundqvist, Sweden	218 6 1/8
1900	A. C. Kraenzlein, U.S.A.	23 6 7/8		PENTATHLON	points
1904	Myer Prinstein, U.S.A.	24 1	1906	H. Mellander, Sweden	24
1906	Myer Prinstein, U.S.A.	23 7 1/2	1912	F. R. Bie, Norway	16
1908	F. Irons, U.S.A.	24 6 1/2	1920	E. R. Lehtonen, Finland	14
1912	A. L. Gutterson, U.S.A.	24 11 1/5	1924	E. R. Lehtonen, Finland	16
1920	Wm. Petterson (Bjorneman), Sweden	23 5 1/2		DECATHLON	points
1924	De Hart Hubbard, U.S.A.	24 5 1/2	1912	H. Wieslander, Sweden	7,724.495
			1920	H. Lovland, Norway	6,804.35
			1924	H. M. Osborn, U.S.A.	7,710.775

Appendix

OLYMPIC RECORDS TO 1928

Event	Holder	Yr.	Time	Event	Holder	Yr.	Time	
60 met.	A. E. Kraenzlein, U.S.A.	1900	m. s.	10,000 met.	G. H. Goulding, Canada	1912	m. s.	
"	A. Hahn, U.S.A.	1904	7	Walk ..	G. C. Weightman-Smith	1928	46 28 2/5	
100 "	D. F. Lippincott, U.S.A.	1912	} 10 3/5	Hurdles	South Africa		- 14 3/5†	
"	H. M. Abrahams, Gt. B.	1924			200 met.	H. L. Hillman, U.S.A.	1904	- 24 3/5
"	P. Williams, Canada	1928			Hurdles	Lord Burghley, Gt. Brit.	1928	- 53 2/5
"	J. E. London, Gt. Brit.	1928			400 Met.	M. Taylor, U.S.A.	1928	
"	R. F. McAllister, U.S.A.	1928		Hurdles			ft. ins.	
200 met.	A. Hahn, U.S.A.	1904	} 21 3/5	Running	H. M. Osborn, U.S.A.	1924	6 6	
"	J. V. Scholz, U.S.A.	1924			High Jump	E. B. Ham, U.S.A.	1928	25 4 3/4
"	H. Kornig, Germany	1928			Running	(R. Legendre, U.S.A., jumped 25 ft. 6 in. in pentathlon competition, Paris, 1924)		
400 "	E. H. Liddell, Gt. Brit.	1924	- 47 3/5	Broad Jump				
800 "	D. G. A. Lowe, Gt. Brit.	1928	1 51 4/5					
1,500 "	H. E. Larva, Finland	1928	3 33 1/5					
5,000 "	P. Nurmi, Finland	1924	14 31 1/5					
10,000 "	P. Nurmi, Finland	1928	30 18 4/5					
400 Metres Relay ..	U.S.A. (F. Hussey, L. A. Clarke, L. Murchison, J. A. Leconey)	1924	} 41*	Hop, Step & Jump	A. W. Winter, Australia	1924	50 11 1/4	
"	U.S.A. (F. Wykoff, H. Russell, C. Borah, J. Quinn)	1928			Pole Vault	S. W. Carr, U.S.A.	1928	13 9 3/8
"	U.S.A. (G. Baird, F. Alderman, E. Spenser, R. Barbutti)	1928			Discus	C. Houser, U.S.A.	1928	155 2 35/16
1,600 met. Relay ..	Finland (P. Nurmi, V. Ritola, E. Katz)	1924	8 32	Throw Javelin	E. H. Lundqvist, Sweden	1928	218 6 1/8	
3,000 met. Team ..				16lb. Shot Put	J. Kuck, U.S.A.	1928	52 0 11/16†	
3,000 met. Steeplechase	Loukola, Finland	1928	9 21 4/5†	16lb. Hammer Throw	M. J. McGrath, U.S.A.	1912	179 7 9/16	
				56lb. weight Pentathlon	P. J. McDonald, U.S.A.	1920	36 11 1/2	
				Decathlon	E. R. Lehtonen, Finland	1920	14 pts.	
					J. Yrjölä, Finland	1928	8,053.29 pts.	

*Equals World's Record.

†World's Record.

NATIONAL RECORDS

AMERICAN.				BRITISH.		
Event	Time or Distance	Holder	Yr.	Time or Distance	Holder	Yr.
100 yds.	h. m. sec.		1926	h. m. sec.		
220 "	- 9 1/2	C. W. Paddock, U.S.A.	1921	- 9 7/10	E. H. Liddle, Scotland	1923
440 "	- 20 4/5	C. W. Paddock, U.S.A.	1924	- 21 1/5	W. R. Applegarth, Eng.	1914
	- 47	M. Long (str. away), U.S.A.	1916	- 48 2/5	W. Halswelle, Scotland	1908
	- 47 2/5	J. E. Meredith, U.S.A.	1916			
		(around a turn 1/3 mi. track)	1916			
880 "	- 1 52 1/5	J. E. Meredith, U.S.A.	1915	- 1 51 3/5	O. Peltzer, Germany	1926
1 mile	- 4 12 3/5	N. S. Taber, U.S.A.	1915	- 4 13 4/5	A. G. Hill, England	1921
3 miles	- 14 22 3/5	H. Kolehmainen, Finland	1913	- 14 17 3/5	A. Shrubbs, England	1903
4 "	- 20 2	H. Kolehmainen, Finland	1913	- 19 23 2/5	A. Shrubbs, England	1904
10 "	- 51 3 2/5	H. Kolehmainen, Finland	1909	- 50 40 3/5	A. Shrubbs, England	1904
20 "	- 1 58 27 3/5	J. Clark, U.S.A.	1909	1 51 54	G. Crossland, England	1894
30 "	3 17 36 1/2	J. A. Squires, England	1885
40 "	4 46 54	J. E. Dixon, England	1884
50 "	6 13 58	E. W. Lloyd, England	1896
HURDLE RACING						
120 yds. (3' 6")	- 14 2/5	E. J. Thomson, Canada	1920	- 14 4/5	{ E. J. Thomson, Canada Lord Burghley, Eng.	{ 1920 1927
220 " (2' 6")	- 23	C. R. Brookins, U.S.A.	1924	- 24 4/5	{ Lord Burghley G. C. Weightman-Smith	{ 1925 1928
440 " (3')	- 52 3/5	J. A. Gibson, U.S.A.	1927	- 54	Lord Burghley, Eng.	1928
WALKING						
1 mile	- 6 29 3/5	F. P. Murray, U.S.A.	1883	- 6 26	G. E. Larnar, England	1904
2 miles	- 13 37	G. H. Goulding, Canada	1916	- 13 11 2/5	G. E. Larnar, England	1904
4 miles	- 28 6 1/5	G. H. Goulding, Canada	1912	- 27 14	G. E. Larnar, England	1905
7 miles	- 50 40 4/5	G. H. Goulding, Canada	1915	- 50 50 4/5	G. E. Larnar, England	1905
10 miles	- 1 17 40 3/4	E. E. Merrill, U.S.A.	1880	1 15 57 2/5	G. E. Larnar, England	1908
30 "	J. B. Clark, U.S.A.	4 29 52	J. Butler, England	1905
50 "	7 52 27	J. Butler, England	1905
100 "	18 4 10 1/5	T. E. Hammond, Eng.	1908
FIELD EVENTS						
High Jump	ft. ins.	H. M. Osborn, U.S.A.	1924	ft. ins.	B. H. Baker, England	1921
Long Jump	6 8 1/4	E. B. Ham, U.S.A.	1928	6 5	E. B. Ham, U.S.A.	1928
Pole Vault	25 11 7/8	S. W. Carr, U.S.A.	1927	25 11	L. Barnes, U.S.A.	1928
Hop, Step, Jump	14 0	S. W. Carr, U.S.A.	1927	13 9	C. J. Lindh, Sweden	1922
Hammer Throw	50 11	D. Ahearne, Irish-American	1911	50 9	W. Peters, Holland	1927
Weight Putting	189 6 1/2	P. J. Ryan, Irish-Amer.	1913	172 3 1/2	C. J. Lindh, Sweden	1922
Javelin Throw	51 0	R. Rose, U.S.A.	1909	49 6	H. Brix, U.S.A.	1928
	212 4	T. Myrva, Finland	1925	222 9	S. Lay, New Zealand	1928

Athletics of To-day

NATIONAL RECORDS—*continued.*

AMERICAN				BRITISH			
Event	h. m. secs.	Holder	Yr.	h. m. secs.	Holder	Yr.	
RELAY RACING							
440 yards .. (4 at 110 yds.)	- 41	Newark A.C. ..	1927	- 42 1/5	C.F.C. Preussen Krefeld, Germany	1927	
880 yards .. (4 at 220 yds.)	1 25 4/5	Univ of S. California ..	1927	1 28 2/5	Achilles Club ..	1927	
1 mile .. (4 at 440 yds.)	3 16 2/5	American Legion ..	1921	3 13 2/5	U.S.A. ..	1928	
1 mile medley .. (440, 220, 220, 880)	3:22 3/5	British Empire ..	1928	
2 miles .. (4 at 880 yds.)	7 41 2/5	Boston A.A. ..	1926	7 53 1/5	British Empire ..	1920	
4 miles .. (4 at 1 mile)	17 21 2/5	Illinois A.C. ..	1923	17 22 3/5	British Empire ..	1928	

UNIVERSITY RECORDS

OXFORD AND CAMBRIDGE				BRITISH PROVINCIAL UNIVERSITIES			
Event	Time or Distance	Holder	Yr.	Time or Distance	Holder	Yr.	
100 yards ..	min. secs.	A. E. Porritt, Magdalen, Ox.	1925	min. secs.	J. E. London, London ..	1927	
220 ..	- 9 9/10	- 10 15/100	J. W. Thwaite, Liverpool	1923	
440	D. Macmillan, Trinity, Cam.	1912	- 22 2/5	J. V. S. Milne, Leeds ..	1924	
880 ..	49 2/5	K. Cornwallis, Univ., Ox. ..	1904	- 50 98/100	E. A. Johnstone, Manches.	1925	
1 Mile ..	1 54 4/5	C. C. Henderson-Hamilton, Trinity, Ox.	1905	2 3 1/5	D. J. P. Richards, Aberystwyth	1926	
3 ..	4 17 4/5	4 32	B. C. V. Oddie, London ..	1926	
120 yds. hurdles ..	14 34 4/5	G. M. Sproule, Balliol, Ox. ..	1914	15 16 4/5	A. S. Prowse, Bristol ..	1922	
.. ..	- 15 2/5	G. C. Weightman-Smith, Selwyn, Cambridge ..	1928	- 16 2/16	
220 yds. hurdles ..	- 24 4/5	{ Ld Burghley, Mad'len, Cam G. C. Weightman-Smith, Selwyn, Cam. ..	1925 1928	
440 yds. hurdles	- 59 3/5	D. McC. Bone, Liverpool	1925	
Long Jump ..	ft. ins.	H. M. Abrahams, Caius, Cam	1923	ft. ins.	A. Gee, Nottingham ..	1923	
High Jump ..	23 7 1/4	M. J. Brooks, B.N.C., Ox. ..	1876	22 4 1/2	J. E. London, London ..	1926	
Pole Vault ..	6 2 1/2	G. P. Faust, St. C., Ox. ..	1928	5 10 1/2	J. W. Jessen, London ..	1927	
Shot Put ..	12 0	W. W. Coe, Hertford, Ox. ..	1903	10 0	K. H. Pridie, Bristol ..	1927	
Hammer Throw ..	43 10	G. E. Putman, Christch., Ox.	1911	41 0	
Javelin Throw ..	*153 3	
Discus Throw	163 3	W. P. Abell, Notts. ..	1928	
..	120 7 1/2	K. H. Pridie, Bristol ..	1926	

* In 1921 M. C. Nokes, Magdalen College, Oxford, after winning the event at 148 ft. reached 160 ft. 5 ins. in an exhibition throw.

OXFORD AND CAMBRIDGE RELAY RECORDS

Event	m. s.	Holder	Year
400 yds (4 × 100 yds.)	- 38 2/5	Oxford (G. C. Craddock-Watson, C. F. Gates, B. M. Norton, H. V. Warren)	1928
1/2 mile (4 × 220 yds.)	1 28 2/5	Oxford (B. M. Norton, H. Gonin, H. V. Warren, R. Leigh-Wood)	1928
1 mile (4 × 440 yds.)	3 23	Oxford (D. L. Cooke, W. N. Harrison, G. C. Craddock-Watson, R. Leigh Wood)	1928
2 mls. (4 × 880 yds.)	8 3 2/5	Cambridge (D.P.L. Tindall, C. E. Davis, H. B. Stallard, D. G. A. Lowe)	1922
4 miles (4 × 1 mile)	18 8 1/5	Cambridge (J. Scrimgeour, P. N. Durlacher, W. R. Seagrove, H. B. Stallard)	1922
480 yds. High Hurdles (4 × 120 yds.)	1 3 1/5	Cambridge (G. C. Weightman-Smith, H. P. Bowler, T. C. Livingstone-Learmonth, Lord Burghley)	1926
1/2 mile Low Hurdles (4 × 220 yds.)	1 44	Oxford (J. A. Stevens, L. R. Percival, R. St. G. T. Harper, H. Moore)	1927

Appendix

361

BRITISH PUBLIC SCHOOLS CHAMPIONSHIPS RECORDS

Event	Inst.	1st Winner	Time or Distance		Stand-ard	Record Holder	Time or Distance		Rec. made
			m. s.	m. s.			m. s.	ft. ins.	
100 yds.	1897	A. M. Leggatt, Bedford	- 11	- -	- -	C. F. N. Harrison, Eton R. S. Rowlands, City of London	- 10 2/5 - 10 2/5	{ 1923 1926	
440 yds.	1890	T. C. Eastley, Haileybury	- 55	- 55	- 55	D. B. Hudson, Imperial Service College	- 52	1927	
880 yds.	1897	G. E. Barry, St. Paul's	2 6 4/5	2 10	2 10	H. S. Townend, St. Edmund's, Canterbury	2 1 3/5	1927	
1 mile	1896	H. Elliott, Giggleswick	4 42 3/5	4 50	4 50	J. E. Robins, Lancing	4 31 4/5	1929	
1 Mile Walk	1919	E. C. Archer, Mer. Tay.	8 57 3/5	8 15	8 15	J. Carne, Polytechnic	7 32	1923	
120 yds. Hurds.	1896	W. N. Pilkington, Clifton	- 17 2/5	- -	- -	E. Cawston, Lancing	- 16 2/5	1929	
1/4-Mile Steeplechase	1897	W. Winterbotham, St. Paul's	4 5 4/5	4 20	4 20	V. E. Morgan, Charterhouse	4 3 3/5	1923	
High Jump	1897	N. S. A. Harrison Haileybury	5 5	5 3	5 3	H. A. Simmons, Southampton	5 10 1/2	1928	
Long Jump	1897	N. S. A. Harrison, Haileybury	20 4 1/2	19 0	19 0	J. Simpson, Oundle	22 3 1/2	1928	
Pole Vault	1925	O. G. Crossman, Bedford	9 1 1/2	8 6	8 6	H. G. Young, Bed. Mod.	10 1	1928	
Discus	1929	G. M. Moll, Bedford	114 6 1/4	90 0	90 0	G. M. Moll, Bedford	114 6 1/2	1929	
Javelin	1929	R. A. C. Burnett, Malv.	71 46 8	115 0	115 0	R. A. C. Burnett, Malv.	146 8	1929	
Shot (12 lb.)	1929	R. A. Gerrard, Taunton	37 10	30 0	30 0	R. A. Gerrard, Taunton	37 10	1929	
Junior 100 yds.	1914	H. Day, Bedford	- 11 1/5	- -	- -	J. Heap, Latymer Up.	- 10 3/5	1923	
Junior 250 yds.	1914	K. K. White, Barnet	- 29 3/5	- -	- -	A. J. Ford, Sloan	- 28 1/5	1927	
Jnr. High Jump	1914	E. Fisher, Emmanue I.	4 10	- -	- -	G. M. Moll, Bedford	5 5	1927	

SERVICES CHAMPIONSHIPS RECORDS

ROYAL NAVY AND MARINES				ARMY			ROYAL AIR FORCE		
Event	Time or Distance	Holder	Yr.	Time or Distance	Holder	Yr.	Time or Distance	Holder	Yr.
100 yds.	m. s. - 10	Ldg.-Seaman Finch	'25	m. s. - 10	Sgt.-Instr. H. C. Hunt	'28	m. s. - 10 1/5	Sgt.-Maj. F. Mawby	'24
220 "	- 23	Lt. F. W. Bourne	'28	- 22 1/5	L.-Sgt. H. C. Hunt	'25	- 22 4/5	L.-A.-C. B. L. Olney	'27
440 "	- 52	A. B. Lomax	'27	- 51 1/5	Lt. H. C. Partridge	'27	- 52 3/5	P.-O.C.P. Vines	'26
880 "	2 2 1/5	Ldg.-Seaman McDonald	'28	2 0	Lt. J. P. A. Graham	'25	2 0 4/5	Sgt. L. S. Snaith	'27
1 mile	4 35	Ldg.-Seaman Bloomfield	'28	4 29 4/5	Cpl. W. Cotterell	'26	4 20 1/5	A.-C. R. Thomas	'28
3 miles	15 16 1/5	A. B. Humphreys	'28	14 33 4/5	Cp. W. Cotterell	'26	15 6 3/5	L.-A.-C. G. W. Goodall	'26
120 yds. Hurdles	- 15 2/5	Lt. D. M. L. Neame, R.N.	'27	- 15 2/5	2nd Lt. Lord Burghley	'28	- 16	A.-A. D. O. Findlay	'28
High Jump	ft. ins. 5 10	Lt. F. M. Stephenson	'25	ft. ins. 5 10 1/2	2nd Lt. H. R. Norman	'26	ft. ins. 6 0 1/4	F.-O. F. E. Nuttall	'26
Long Jump	21 11	Lt. M. W. Fly, R.A.N.	'25	22 4	Cpl. J. Long	'27	22 2 1/4	F.-O. H. D. L. Neame	'28
Pole Vault	- -	- -	- -	10 6	L.-Sgt. H. Crawley	'27	8 2	*F.-Sgt. Bradbury	'24
Shot Put	37 1 1/2	Ldg.-Seaman Plaipe	'27	43 9 1/2	Capt. J. A. Ross	'27	37 5 1/2	P.-O. T. R. Hope	'28
Discus	- -	- -	- -	117 3 1/2	Lt. K. S. Jefferson	'27	- -	- -	'28
Throw Javelin	- -	- -	- -	159 3	C. Q. M. S. Sayers	'27	134 7*	F.-O. Harcourt-Vernon	'24
Throw Hammer	- -	- -	- -	119 8 1/2	Sgt.-Dmr. J. McGowan	'28	- -	- -	'28
2 miles Walk	- -	- -	- -	- -	- -	- -	m. s. 14 56 2/5	*Cpl. Worrall	'26
440 yds (low) hurds.	- -	- -	- -	- -	- -	- -	- 59 4/5	*Sgt. Lowdell	'24

* Non-Championship Events.

- Cartwright, G., 130
 Casey, L., 222
 Casting the Barre, 2
 Castleham, Lord, 3
 Cator, S., 207, 208
 Chambers, J. G., 176, 177
 Chapman, M., 46
 Chappell, 169
 Charles II, 3
 Charterhouse, 10
 Cheltenham College, 9
 Chinnery, W. M., 10, 11, 92, 169
 Christ Church Coll., Ox., 9, 12
 Christiernsson, C., 137, 138, 143, 153
 Civil Service A.A.A., 12.
 Clapp, R. G., 228, 230
 Clark, 117
 Coe, W. W., 326, 339, 340. *Pl.* 60
 Cohen, H. J., 208
 Colbeck, E. J., 11, 56, 57, 59, 61, 63, 204
 Collier, J., 139
 Colmore, T. M., 43
Complete Gentleman, 298
 Connolly, J. B., 219
 Cook, E. T., 231
 Cook, L. A. B., 171
 Cook, M., 107
 Cook, Sir Theodore, 116
 Copland, A. F., 151, 205
 Cornell, Univ. of, 39, 175
 Cornish, L., 64
 Cornwallis, K., 68
 Corson, J., 286
 Corts, 49
 Cotterell, Corporal, 99
 Counties Athletic Union, formation of, 23, 172
 County Athletic Associations, 22, 23
 County Championships, 22, 23, 108
 Couriers, 126
 Courberlin, Baron Pierre de, 25, 26, 35
 Cowburn, R. E., 175
 Cowie, J. M., 45
 Craig, R. C., 48
 Cregan, J. F., 175
 Cremin, D. P., 255
 Crick Run founded, 7, 91, 164, 167, 169
 Croome, A. C. M., 133, 134, 228
 Cross Country, N. of Thames Championship, 84
 Crossland, G., 93, 120
 Crossman, O. C., 235
 Crouch Start, 41, 49, 50, 51
 Croydon, Butcher of, 3, 4
 Cuculain, 298
 Cubel, F. J., 155
 Cummings, W., 79, 80, 183
 Curtis, H., 178
 Daft, C. F., 133
 Dale, Fritbol, 232
 Dairympole, J., 258, 259, 273
 Daniel, A. W. T., 132
 Daranyi, J., 331, 338. *Pl.* 61
 Darbyshire, S. B., 43
 Darius, 115
 David, King, 253
 Davis, E. J., 205
 Davis, W. C., 127
 Davenport, H., 16
 Davenport, I. N., 60
 Day, W. D., 175
 Decathlon, 57
 Degland, R., 259
 Desborough, Lord, 117. *Pl.* 4
 Desmarteau, 27
 Despard, L. F. E., 187
 Dineen, M. D., 219, 220
 Dinnie, Donald, 184
 Discobolus, 278, 279. *Pl.* 45
 Dole, M., 230
 Donovan, T. M., 25
 Dorando, P., 5, 116, 117, 118, 119, 123. *Pl.* 15
 Douglas, J. H., 16
 Dowson, C. S., 180
 Doyle, Sir A. Conan, 282
 Droegmuller, W., 234, 243
 Duffey, A. F., 46, 47
 Duhour, E., 331
 Duncan, J. H., 282, 283, 284
 Duncnker, V., 137
 Durham University 9
 Dyas, G., 140, 141
 Dye, L., 139
 Eardley-Wilmot, Captain, 7
 Eastern Cut-Off style, 194, 196, 199, 201. *Pl.* 25, 26
 Eastley, T. C., 64
 Eaton, W. F., 204
 Edward VII, 29
 Edward, H. F.V., 48, 52, 53, 347. *Pl.* 6
 Edward III, 2, 321, 323
 Edwards, P., 73, 74
 Edwards, W. A. M., 171
 Egri, K., 285, 286
 Ellis, C., 89. *Pl.* 11, 14
 Emmanuel College, Cambridge, 9
 Emsley, 133
 Englehardt, H., 73, 74
 Enck, S. C., 72
 English A.A.A. Championships, foundation of, 2, 11, 13, 14, 15, 16, 18, 23, 24, 42; first foreigner captures title, 43; youngest champion, 44; first black man to win, 45; first javelin championship, 254, first discus championship, 282
 Erikson, V., 235
 Eton College, 7; sports instituted by, 8, 9; produce phenomenal schoolboy athlete, 43, 132; steeplechase, 167
 Eustace, E. A., 255
 Evenson, C., 281
 Exeter College, Oxford, 7
 Eyles, Corp. R. F., 259
 Facelli, L., 154, 155
 Fairs and Wakes, dying out, 4
 Faust, G. P., 248
 Fenner's Ground, 141
 Fernando, Altimani, 179
 Ferris, Corp. S., 121, 122, 123, 124. *Pl.* 15
 Fisher, P., 259
 Fitch, H. M., 62
 Fitzherbert, 59
 Flack, 27
 Flanagan, John, 300, 301, 303, 309, 310, 312. *Pl.* 34
 Flaxman, A. E., 255, 282, 289, 290, 299, 302, 303, 304, 305, 309, 310, 311, 312, 313, 316, 317. *Pl.* 47, 48, 53, 54, 55, 56, 57
 Ford, H., 286
 Forshaw, 118
 Foss, Frank, 232, 233. *Pl.* 32
 Fowler-Dixon, J. E., 128, 130, 163. *Pl.* 12
 Franklin Field, Philadelphia, 110. *Pl.* 62
 "Freak" matches, 96
 Fraser, C., 322
 Frazier, I., 205
 Freude, 174
 Friegrio, Ugo, 180
 Fry, C. B., 25, 205
 Fyfe, A. H., 254
 Gaby, F. R., 138, 139, 141, 142, 143, 148. *Pl.* 20
 Gaches, H. C., 333
 Gainsford A. C., 84
 Gallo, 2
 Games, Olympic (*see* Olympic)
 Games, Northern, 1, 253
 Games, Taitlin, 1, 21, 253, 298, 321
 Gardiner, N. E. Norman, 278
 Garnett, R. C., 91, 161
 Garner, E. S., 133
 Garrett, R. S., 281
 Gemelin, 27
 Gentlemen of Hampstead, 169
 Georgantas, G., 280, 324
 George, A. B., 162
 George, J. P., 46, 47
 George, W. G., 16, 58, 68, 79, 80, 81, 92, 93, 101, 102, 170. *Pl.* 12
 Gibb, James, 92
 Gibson, Johnny, 154, 155, 156, 158. *Pl.* 21
 Giffin, M. H., 281
 Gifford, J. H., 96
 Gilbert, A. C., 231
 Gill, 192
 Gillis, Duncan, 302. *Pl.* 45
 Gillis, S. P., 301, 302
 Githam, C. W., 119, 123
 Glazebrook, M. G., 185, 186
 Glover, E., 98, 104, 231
 Gold, 241
 Gonder, F., 231. *Pl.* 32
 Gooch, F. H., 204
 Goodbody, F. W., 208
 Goodwin, G. R., 180, 181
 Gordon, C. E. S., 195, 196
 Goulding, 27
 Goulding, G. H., 178, 179
 Gourdin, E., 205, 206
 Grace, W. G., 204
 Graham, G., 233
 Graham, H. E., 68
 Grant-Asber, A. G., 204
 Grant, A., 96
 Graveley, J. G., 229

- Gray, E. A., 298
 Grav, G., 324, 341
 Green, C. E. J., 180
 Green, H., 120
 Green, R. W., 68
 Greer, E. B., 152
 Gregson, H. W., 78
 Griffith, T., 177
 Groenings, Oswald, 152
 Guillemot, J., 99, 171
 Gutterman, Albert, 206
- Hackner, Y., 257
 Hahn, Lloyd, 61, 70, 73, 74, 75, 88, 89. *Pl.* 9, 11, 14
 Hales, G. H., 299
 Halswelle, Wyndham, 59
 Halton, J., 6
 Ham, E. B., 109
 Ham, Ed., 208, 215, 216, 217. *Pl.* 29
 Hammond, T. E., 179
 Händchen, 286
 Handicapping, curious method of, 8
 Hare, Wallace R., 23
 Harlemann, C., 243, 249. *Pl.* 36
 Harper, E., 102, 122, 173
 Harrison, W. N., 208
 Harrow School, 9
 Hart, H., 332
 Hartman, G., 285, 330. *Pl.* 59
 Harvard, University of, 20
 Hatton, Fred., 117
 Hawtrej, 169
 Hawtrej, H. C., 81
 Hayes, 6
 Hayes, Johnny, 97, 117, 118, 119, 123
 Hefferson, C., 117, 118
 Helgesson, C. E., 281
 Henderson-Hamilton, C. C., 79
 Henderson, W. E. B., 142, 253, 255, 282, 291, 335. *Pl.* 46, 50, 58
 Hennemann, C. H., 281
 Henry II, 2
 Henry V, 2, 3
 Henry VIII, 2, 298, 321
 Herbert, C., 17, 18, 26
 Hickok, W. O., 300, 325
 Hicks, T. J., 116
 Higginson, J., 221
 High Jump: Sweeney style, 188, 196, 199; Western roll, 188, 191, 192, 196, 197, 198, 200; Eastern cut-off style, 194, 196, 199, 201
 Hillman, H. L., 153
 Hill, A. G., 70, 71, 83, 84, 89, 346. *Pl.* 8, 11
 Hill, A. V., 39, 40, 203
 Hill, W. A., 48
 Hills, R., 329, 330
 Hinkel, Harry, 181
 Hirschfeld, E., 331. *Pl.* 59
 Hitchcock, George, 132
 Hjertberg, E., 124, 211, 302, 306, 329
 Hodge, Percy, 162, 164
 Hoff, Ch., 232, 233, 243. *Pl.* 33
 Hoffman, C., 285. *Pl.* 50
 Hoffmeister, H., 285, 286, 290, 291. *Pl.* 48
- Hogan, H. A. V., 333
 Hogsflesh, Geo, 322
 Hohenthal, A., 256
 Holmes, Randel, 2
 Homer, 278
 Honner, R. St. J., 208
 Horgan, D., 325, 326, 335. *Pl.* 58
 Horgan, Denis, 25
 Horine, George, 191, 192, 202
 Horr, M. H., 281
 Horton, E. C., 179
 Houben, 49
 Housden, E. F., 235
 Houten, J. Van, 228, 230
 Houser, C., 285, 286, 289, 329, 330, 331, 336, 337. *Pl.* 47, 61
 Howard-Smith, M.C., Lt-Gen, 305
 Howland, R. L., 33, 328, 338. *Pl.* 59
 Hubbard, H. de H., 205, 206, 208, 209, 210, 221
 Hughes, T., 169
 Huhn, Trevis, 138, 152
 Hunter, Evan. *Pl.* 4
 Hunter, W., 208
 Hurding (High), points to bear in mind, 145; Exercises for, 146-147. *Pl.* 16, 17, 18, 20; (Low), training and technique, 156-160. *Pl.* 21
 Hutson, G. W., 96, 98, 99
- Ifley Road, 141
 Imbach, J., 62
 Inter-Collegiate A.A.A.A., 19
 Inter-Collegiate Cross-Country Association, 175
 Inter-Countries Cross-Country Championship, 172
 Inter-Scholastic Championship, 175
 Inter-Scholastic Championships, 29
 Inter-University Athletic Board of Great Britain and Ireland Championships, 31
 International Athletics, 31
 International matches, first impulse to, 25; triangular, 25
 International Olympic Committee, 26
 Ireland, first International match, 16, 24
 Isuda, H., 122, 123, 126
 Italy, King of, 116
- Jack, T., 117
 Jackson, B., 19
 Jackson, C. N., 17, 18
 Jackson, J., 305
 Jackson, Lt.-Col. A. M. S., 82, 83, 108
 Jaervinen, 222
 Jaervinen, W., 280, 281, 283
 James, R. J., 310
 Jansson, B., 330, 331
 Jansson, F., 221, 225, 233. *Pl.* 30
 Japan, 34
 Jarvinen, K., 331. *Pl.* 61
 Jeppe, H., 138
 Jersey, Earl of, 18, 78
- Johnson, R. E., 173
 Johnson, P., 258
 Johnstone, 99
 Jones, J. Paul, 79, 81, 82, 86
 Jones, T. E., 143, 211
 Jordan, G., 24
 Junker, L., 43
- Kasahara, H., 234
 Katz, E., 99
 Keller, I., 72, 74
 Kelly, F., 135, 136
 Kennedy, Kenneth, 59
 Kennelly, Professor, 315
 Kensington, G. S., 9
 Kentish, Brig.-Gen. R. J., 108
 Kerr, R., 28, 47
 Kibblewhite, J., 93
 Kieselhorst, S. B., 156. *Pl.* 21
 Kiely, 300
 Kilpatrick, C. L., 68
 King, 169
 Kinnunen, 89
 Kinsey, D. C., 138
 Kitching, F. O., 255, 258. *Pl.* 28
 Kivi, A. L., 286
 Kiviat, A. R., 79, 82, 83
 Klumberg, A., 257, 258
 Knourek, Ed., 234
 Knight, E., 8
 Knox, W. R., 321
 Koczan, N., 255
 Kolehmainen, Hannes, 97, 98, 99, 100, 102, 105, 121, 122, 123, 173. *Pl.* 12, 15
 Körmig, H., 40, 52. *Pl.* 7
 Kraenzlein, Alva, 46, 134, 135, 151, 205
 Krenz, E., 331, 332
 Kuck, J., 62, 329, 330, 331, 332, 337. *Pl.* 60
- Lady of the Lake, The*, 321
 Laffan, Rev. R. S. Courcy, 29
 Lambe, H., 68
 Lambrecht, F. L., 324
 Landon, R.W., 109, 190, 193, 201. *Pl.* 26
 Landskamp, 25, 232
 Lane, J., 205
 Langley, H. A., 221
 Larner, G. E., 178, 179. *Pl.* 23
 Larva, H. E., 89, 100
 Laveaux, 174
 Lawes, C. B., 78
 Lawes-Wittwrong, Sir Charles, 78
 Lawrence, W., 300
 Lawther, T. H. B., 333
 Lay, S., 259, 271, 272, 275. *Pl.* 40, 41, 42, 43
 Lazaro, 120
 Leahy, Con, 153, 189, 219
 Leahy, P. J., 189
 Leander Club, 14
 Lee, H. H., 187
 Leeke, H. A., 254, 280, 300, 322
 Leeke, Henry (the elder), 299, 322
 Legard, Sir Chas., 8
 Legendre, Robert, 62, 207
 Legg, W. B., 49

- Leigh-Wood, R., 113. *Pl.* 8, 14
 Leinster, Book of, 1, 298, 321
 Lemmer, E., 253, 254, 255, 256, 257, 265. *Pl.* 38, 39
 Lewden, P., 192, 194, 201, 202. *Pl.* 26
 Liddell, Eric, 34, 59, 61, 62, 63. *Pl.* 7
 Lieb, T., 284. *Pl.* 50
 Lietta, P., 260
 Little Bridge, 14, 15, 16, 80, 92, 185, 186
 Lillywhites, Messrs., 257
 Lincoln College, Oxford, 9
 Lincoln, J. C., 258
 Lind, C., 302
 Lindh, C. J., 306, 314
 Lindblom, G., 220
 Lindstrom, "Gunnar," 257, 258, 259, 273
 Ling, Per Henrik, 21, 253
 Lippincott, D., 48
 Little, T. G., 185
 Lively, C. E., 221
 Liversedge, 330
 Livingstone-Learmonth, T. C., 154, 155, 156, 157, 165, 166. *Pl.* 21, 22
 Lloyd, E. W., 129, 130
 Locke, Roland, 49
 Lockton, C. L., 17, 18, 44, 133, 151, 204, 208. *Pl.* 1
 Lomax, H. C., 44, 45
 London Athletic Club, 7, 10, 12, 13, 14, 15, 16, 24, 25, 29, 30, 42, 48, 79, 92
 London, J. E., 31, 49, 54. *Pl.* 2
 Long, Maxey, 46, 56, 63
 Long, M. W., 106
 Long, Pen Pole, 91
 Longboat, Tom, 117, 119
 Loomis, F. F., 153
 Lord, Fred, 116, 120, 123
 Lotings Cup, 48, 49
 Loues, 115
 Loukola, T. A., 89, 100, 163
 Lowe, D. G. A., 34, 35, 59, 60, 64, 68, 70, 71, 72, 73, 74, 75, 84. *Pl.* 4, 9, 10, 13
 Lindberg, E. F. I., 60
 Lucas, 204
 Lugnasad, 1, 21
 Lundqvist, E. H., 200
 Lutyens, W. E., 79
 Lyons, H. S., 106
- Macaulay, R. H., 17, 18
 MacDonald, P., 327, 329, 332
 Macbell, Capt., 8
 MacIntosh, C. E., 208
 MacIntosh, J. D., 325
 Mack, J. J., 193
 Macmaster, C. C., 180
 Macmillan, D., 59
 Magrane, 304
 Mandel, C. S., 151
 Mang, J., 307
 Manhattan A.C., 24
 Marathon Race, Olympic, 1908, 5; description of original Marathon Race, 115; first modern Marathon, 115; epidemic of, 119; standard course, 121
- Martellen, M. B., 122, 123
 Martin, A. J., 333
 Martin, E. *Pl.* 9
 Martin, P., 71, 72
 Martin, Seraphin, 72, 73, 74. *Pl.* 10
 Marvaltis, K., 285, 286, 288, 291. *Pl.* 46, 40
 Mason, C. H., 30
 Mason, C. H., 93
 Mason, Major, 4
 Matches, Pedestrian, 3, 4, 5
 — Amateur, 6
 Matthewman, T. *Pl.* 7
 Matthews, W., 6
 Maxwell, R., 155
 McArthur, K. K., 119, 123
 M.C.C., 14
 McDonald, T. G., 220
 McGinnes, C., 235, 243
 McGrath, Matt, 301, 302, 303, 305, 306, 307, 315, 324. *Pl.* 55
 McIvor, C. C., 10
 McKinnon, D. J., 323, 324
 McLeod-Wright, D., 121, 123
 McManus, W., 220
 McNichol, G., 227
 Meanix, W. H., 152
 Menard, C., 194
 Merchant, Jack, 307
 Merchant Tailors' School, 10, 44
 Meredith, J. E., 5, 59, 60, 61, 63, 64, 70, 71
 Merrill, E. E., 177, 178
 Merton College, Oxford, 9
 Metcalf, J., 6
 Michod, C. J., 161
 Midland Counties A.A.A., 17
 Milligan, W. R., 108, 110
 Mills, J. C., 121, 122, 123
 Milvain, T., 152
 Mincing Lane A.C., 11, 12
 Mitchell, G. T., 284
 Mitchell, J. S., 300, 324
 Mitchell, R. J. C., 185, 205, 227, 228, 322, 323
 Moler, Dr. Ed., 31
 Moll, G. M., 195, 288, 291, 297. *Pl.* 47, 48, 50
 Moll, J. S., 208
 Money Penny, C. J. B., 59
 Monk, Wal., 99
 Montague, E. A., 164
 Montague, F. A., 164
 Montgomery, J., 165. *Pl.* 22
 Morgan, J. H., 91
 Morgan, V. E., 163. *Pl.* 22
 Morgan, W. J., 177
 Morris, W., 64
 Morton, J. W., 46, 47
 Moseley Harriers, 169
 Mostyn, R. V., 184, 309
 Mountain, E. D., 68
 Mucks, A. M., 283
 Mudin, I., 327
 Mugeridge, A. T., 99
 Murphy, Michael, 47, 63, 124, 136, 211
 Mussabini, S. A., 47, 48, 49, 52, 54, 71, 83, 86, 87, 124, 142, 143, 183, 276, 277, 347
 Myers, L. E., 57, 58, 59, 63, 177
 Myron, 278, 279
 Myrra, J., 257, 258, 259, 265, 268, 269, 275. *Pl.* 38, 40
- Nagazawa, V., 234
 Nambu, 222, 225. *Pl.* 13
 Nambu, Chuhel, 31. *Pl.* 30
 National Cross-Country Championships, 169
 Necton Guild, 4, 7
 Nelson, Alec, 124, 141, 142, 211
 Neumann, 72
 Newburn, W. J. M., 205
 News of the World, 129, 306
 Newton, A. F. H., 127; his records, 129-130, 350; training methods, 131. *Pl.* 12
 New York A.C., 24, 25; Relay Team, 106
 Nicholas, T. L., 41
 Nicholson, J. P., 135
 Nicholson, Tom, 302, 303, 306, 308, 312, 315. *Pl.* 54, 55
 Nittymaa, V., 284
 Niklander, E., 283, 284, 327, 329, 330
 Nilsson, E., 329
 Nishida, A. S., 234
 Nokes, M. C., 286, 306, 307, 308, 309, 311, 312, 316. *Pl.* 45, 54, 57
 Northern Counties A.A., 16
 Northern Games, 1, 21, 253
 Norton, J. K., 154, 160
 Nurmi, Paavo, 3, 5, 34, 35, 62, 79, 84, 85, 86, 88, 89, 94, 99, 101, 102, 104, 105, 120, 162, 163, 173, 318, 345, 346, 347, 348, 350; his distance records, 100. *Pl.* 11, 23
- Oberst, E. B., 258
 O'Callaghan, Dr., 298, 307, 308
 O'Connor, P. J., 206, 215, 219, 225. *Pl.* 29, 30
 Oda, M., 221, 222, 223, 225. *Pl.* 31
 Odde, J., 221
 Oddie, B. C. V., 99. *Pl.* 12
 Odssey, *aka*, 278
 Ogilvie, P. B. B., 235
 Ohsawa, Shigenori, 51
 Okita, Yoshio. *Pl.* 4
 Old Marston Ground, 186
 Oler, Wesley, 190
 Oliver, H. M., 169
 Olsen, C. O., 132
 Olympic Games, 1, 21; revival of, 25; Congress at Paris, 1894, 26; first modern Games, 26, 27; and Olympiad, Paris, 1904, 27; 3rd Olympiad, St. Louis, U.S.A., 1904, 27; no British team sent, 94; Intercalated Games, 1906, 27; 4th Olympiad, London, 1908, 28; 5th Olympiad, Stockholm, 1912, 28; 6th Olympiad, 28; 7th Olympiad, Antwerp, 1920, 28, 31, 34; 8th Olympiad, Paris, 1924, 31, 34; 9th Olympiad, Amsterdam, 1928, 31, 34, 35; description of 800 Metres Race, 73, 74
 Oriel College, Oxford, 9
 Orton, G. W., 162
 Osborn, H. M., 57, 192, 193, 197, 198, 199, 202. *Pl.* 24
 Owen, Eddie, 97

- Owen, J., (Jnr.), 41
 Oxford and Cambridge Cross-Country Race, 171
 Oxford and Cambridge Relay Meeting, 110
 Oxford and Cambridge Sports, foundation of, 2, 9; first meeting, 12, 14, 15, 42; half-mile first included, 68
 Oxford Conference, delegates at the, 17, 18
 Oxford University, 8; University Sports instituted, 9, 10, 17, 24
- Paddock, Chas. W., 48, 49, 50, 53, 54. *Pl.* 5, 7
 Parker, C. L., 180
 Partridge, L. F., 141
 Passeman, 190
 Patching, G. H., 42
 Paul, W. C., 79
 Paulus, E., 235, 286
 Pavesi, D., 180
 Pavlov, 353
 Payne, H., 102, 121, 122. *Pl.* 15
 Peacham, 298
 Pearman, J. B., 180
 Pearse, C., 93, 94
 Pedestrians, training and diet of, 5
 Pedestrianism, beginning of, 3; book on, 5; wagers and stakes, 1, 5; palmy days of, 6, 176
 Pelling, E. H., 46. *Pl.* 1
 Peltonen, V., 256, 258
 Peitser Otto, 60, 61, 62, 70, 71, 72, 73, 75. *Pl.* 7, 9
 Pembroke College, 9
 Pendlebury, J. D. S., 141, 186
 Pennsylvania, University of, 20; Relay Meet, 106, 107, 110
 Pentathlon, ancient Olympic, 38; at Penn. Relays, 107
 Penttilä, E., 260, 269, 273. *Pl.* 44
Pepys's Diary, 3
 Petersen, H., 232
 Petersen, N., 180
 Peterson, W., 208, 232
 Petterson, Sven, 137, 138, 154, 155
 Pheidippides, 115, 116
 Phillips, Dr., 38, 39
 Phillips, P. K. O'R., 140
 Phillips, W. P., 44, 45, 58
 Pickard, V., 233, 234, 235, 242
 Pilkington, W. N., 132
 Pirow, O., 255
 Plaw, A. D., 301, 310
 Plaza, M., 121, 123
 Poggioli, A., 307, 308
 Polytechnic Harriers, 110, 120
 Pope, A., 284
 Porhola, V., 328, 329, 330. *Pl.* 61
 Pores, C., 102
 Port Meadow Sports at, 8
 Porritt, A. E., 42, 51
 Porter, H. F., 133, 189
 Powell, V. B. V., 215, 216. *Pl.* 28
 Powell, Foster, 126, 176
 Powell, Kenneth, 133, 134, 140, 141, 148
 Price, 117, 123
 Price, W., 10, 11
 Friele, K. H., 286, 333, 338. *Pl.* 46, 60
 Prince and Princess of Wales, 28
- Princeton, University of, 20
 Prinstein, M., 205, 219
 Prospect Harriers, 175
 Provincial Universities, 31
 Pryor, W., 227
 Pseudonyms, 6, 19
 Public Schools Championships, 29; Challenge Cups, 30; new events added, 1929, 30
 Public Schools Cross-Country Race, 29, 30
 Public Schools Relay meet, 30
 Puritans, Sport under, 2
 Purje, E., 89, 100
- Queen's Club, 24, 108, 141
 Quinn, P., 284, 285. *Pl.* 14
- Raby, J. W., 178
 Rainio, V. J., 221
 Ranelagh Cup, 175
 Ranelagh Harriers, 175
 Rangeley, W., 49
 Rasmussen, G., 180
 Ratcliffe, F., 229
 Ray, Joie, 79, 86, 101, 102, 103, 122, 123. *Pl.* 1
 Ray, T., 229, 230
 Keay, J. H. A., 7, 16
 Reber, C. F., 205
 Records, unreliable 2
 Rector, J. A., 47
 Reidpath, C. D., 59, 60, 62, 63
 Revans, R. W., 208, 215, 217. *Pl.* 28
 Richards, Alva, 192
 Ridley, J. H., 43, 56, 64
 Rinkel, J. W. J., 51. *Pl.* 4, 7, 14
 Ritola, Willie, 34, 35, 99, 100, 102, 103, 173, 174. *Pl.* 23
 Roberts, L. F., 194
 Robins, J., 175
 Rosenfeld, F., 107
 Rose, R., 255, 269, 325, 326, 327, 329, 331, 341. *Pl.* 59
 Ross, G., 323
 Ross, H. V. L., 179
 Ross, J. A., 333
 Rothert, H. P., 332
 Roupell, J. H. I., 185
 Rowden, G. W., 187
 Royal Military Academy, Woolwich, 7
 Royal Military College, Sandhurst, Sports at, 6, 7
 Rudd, B. G. D., 59, 64, 108, 110, 164
 Rugby School, 7, 10, 167, 168
 Running footmen, 3, 126
 Russell, G., 8
 Russell, H. A., 39, 47
 Ryan, J. M., 25, 188, 189
 Ryan, Pat, 305, 309
 Rydberg, 244. *Pl.* 36
 Rye, Walter, 10, 11, 17, 18, 168, 177. *Pl.* 1
- Saaristo, J. J., 255, 256, 258, 268. *Pl.* 40
 Sandow, 303
 Sanders, J., 127
- Sapt, W., 22
 Saul, King, 253
 Scandinavia, 21
 Schofield, S. C. A., 179
 Schools Athletic Association, 30
 Schools Athletic League of New York, 29
 Schools, Sports at, 9
 Schlokot, B., 259, 265, 275. *Pl.* 39
 Schwab, A., 180
 Schwarze, H., 331
 Scientific Experiments, 39, 40, 42, 202, 203, 209, 210, 212, 213, 224, 240, 241, 242, 273, 274, 294, 295, 309, 310, 315, 342, 353
 Scott, 8
 Scott, J., 92
 Scott, L. S., 230
 Scott, Sir Walter, 321
 Scott, W., 98
 Seagrove, W. R., 83, 99, 164
 Sedburgh, 168
 Services Athletics, 33
 Services Inter-Unit Team Championships, 108
 Seward, G., 19
 Sewell, A. N., 173
 Shanahan, D., 220, 222
 Shea, F. J., 59
 Shearman, J., 43, 44
 Shearman, Sir Montague, 16, 17, 18, 43, 44, 186, 333. *Pl.* Frontispiece
 Shepherd's Bush Stadium, 28, 116
 Sheppard, Melvyn, 60, 62, 70
 Shendan, M., 279, 280, 281, 324. *Pl.* 45
 Sherrill, C. H., 41
 Sherring, W. J., 96
 Shrewsbury, 7; steeplechase, 167, 168
 Shrub, A., 81, 94, 95, 96, 102, 119, 170. *Pl.* 12
 Silverstrand, C. *Pl.* 52
 Silhouette, D. de, 258
 Sulkanemi, W., 256
 Simmons, H. A., 153, 193, 194, 195, 200, 202, 203. *Pl.* 25, 27
 Simpson, J. G., 208
 Simpson, R. I., 151
 Simpson, R., 135, 136, 143
 Sinclair, A. W., 127
 Sköeld, O., 307, 308
 Slack, D. G., 221
 Slade, W., 92, 161
 Sloane, Wm. M., 26
 Smith, E., 107
 Smith, H., 235
 Smith, S. P., 177
 Smithson, Forrest, 135, 140
 Snook, W., 79, 93, 162, 170
 Sockalexis, A., 119
 Soderstrom, B., 231. *Pl.* 32
 Somody, Dr., 153, 189
 South London Harriers, 169
 Southwell, M., 8
 Spartan Harriers, 169
 Spearow, A. R., 234
 Spencer, E., 106
 Spencer, F. J., 94, 95
 Spicer, 10
 Sprinting, English action, 52, 53
 American type, 53
 Sportarticles, Messrs, 256

- Sporting Gazette*, 131
Sporting Life Trophy, 120
 Sports, suppressed by Puritans, 2; at fairs and wakes, 4; early forms of, 2, 4; prizes at early meetings, 4
 Squires, J. A., 128, 130
 St. Albans, 9
 St. John's College, Camb., 9
 Stallard, H. B., 64, 83, 84, 98, 110. *Pl.* 11
 Stamford Bridge Ground, 16, 23, 28, 33, 107, 109, 141
 Starr, R. S., 71, 73
 Statius, 278
 Stanning, P. H., 169
 Steinbrenner, G., 284, 285
 Steinerud, H., 286
 Steynroos, Albin, 34, 102, 121, 123, *Pl.* 15
 Stevenson, W. E., 59
 Stock Exchange, 92, 95
 Stones, E. L., 229, 230
 Strachan, E. A., 229
 Strachan, H. W., 229
 Strobins, G., 119
 Studenroth, 174
 Sturges, W. J., 178
 Sturdy, F. H., 244, 249. *Pl.* 37
 Sullivan, J. E., 280, 345
 Sumiyoshi, K. *Pl.* 44
 Sunde, O., 259, 260
 Sutherland, E. G., 259
 Svanberg, J. F., 97
 Svenson, A., 132
 Svenson, M., 306
 Sweden, 21; Sports Associations of, 22; Championships founded 253
 Swedish Schoolboys' Athletic Week, 29
 Sweeney, M. F., 25, 187, 188, 189, 190; style of high jumping, 188, 196, 199
 Szepes, Bela, 259, 260, 264. *Pl.* 39, 44

 Taber, N. S., 82
 Taitlin Games, 1, 21, 253, 298, 3217
 Taipale, A. R., 283, 284, 285
 Talbot, D. L. J., 302
 Tammer, E., 329
 Tatham, W. S., 71, 72, 73, 110
 Taylor, A. R., 72
 Taylor, F. M., 106, 153, 155
 Tchitcherine, F. W., 64
 Teato, 116
 Tennent, W. M., 43, 56
 Tetlow, 6
 Thames Handicap Steeplechase, 168
 Thames Hare and Hounds, 17, 168, 169
 Thames Rowing Club, 168
Thebesis, 278
 Thom, Walter, 3, 176
 Thomas, Ivor, 171
 Thomas, Sid, 93, 96

 Thomson, Earl, 132, 136, 137, 144, 148. *Pl.* 16, 19
 Thornton, P. M., 68
 Thornton, G. R., 298
 Three Right Angles Theory, 135
 Tindall, H. C. L., 59
 Tiren, L. E., 233
 Tisdall, R. M. N., 140, 328, 332
Tom Brown's School-days, 168, 169
 Tootell, F. D., 307, 308
 Torpo, K. J., 329
 Toulikoura, 222
 Townsend, H. S. *Pl.* 10
Track and Field, 143
 Training and diet of Pedestrians, 5; of Amateurs, 11
 Training—for sprints, 54, 55; for quarter-mile, 66, 67; for half-mile, 76, 77; for mile, 102, 103, 104, 105; Relay Teams, 110-114; Marathon, 124, 125
 J. E. Fowler-Dixon's method, 128; Hurdles, 149-150; Steeplechase, 166; Cross-Country, 172; Long Jump, 216; Hop, Step and Jump, 225; Pole Vault, 252; Javelin, 276; Hammer, 318-320; Shot, 340
 Tremeer, L. F. ("Jummy"), 47, 153
 Tripplin, E. C., 43, 44, 46
 Trosbach, 137
 Tuulos, V., 221, 222
 Turner, G., 196

 Uebler, W., 331, 332
 Ulverstone Cricket Club, 228
 Ulysses, 278
 United States, A.A.U. of, 19
 Upcher, H. K., 133

 Van Geyzel, C. T., 193, 194, 196
 Venn, H., 177
 Victoria, Queen, 30
 Victory Cup Meeting, 108
 Vilen, E., 154, 155
 Viljoen, 138
 Voigt, Emil, 97

 Waddell, J. and W., 16, 17, 18
 Wadham College, Oxford, 9
 Wadmore, J. F., 1 95
 Wadsley, R. W., 47
 Wahlstedt, A. I., 323, 331, 332
 Wakeman, W. H., 132
 Walker, Donald, 6, 184, 209
 Walker, R. E., 28, 46, 47, 48, 209
 Wallace, J. P., 328
 Walsh, Con., 301, 302
 Warburton, "Choppy," 92
 Ward, 204
 Ward, Ben, 136
 War period, 28, 29, 30, 31
 Ware, J. H., 325
 Washington, Geo., 18
 Waseda University, 31, 51, 234

 Watson, Ray, 73
 Webb, Col. G. Crighton, 19
 Webb, E. J., 178, 179
 Watson, R., 229
 Webster, F. A. M. *Pl.* 40, 46, 48, 49
 Webster, F. R., 148, 235. *Pl.* 20, 34
 Webster, H., 177, 178
 Webster, Joan, 235. *Pl.* 37
 Webster, J. E., 99, 163, 165. *Pl.* 22
 Webster, Peggy, 235. *Pl.* 37
 Webster, R. E., 78, 92, 161, 169
 Weetwood, 141
 Wefers, B. J., 40, 42, 106
 Weightman-Smith, G. C. 136, 137, 138, 139, 148, 152, 259. *Pl.* 20
 Welton, 118
 Wendell, J. I., 151
 Western Roll, 188, 191, 192, 196, 197, 198, 200, 354. *Pl.* 24
 Westing, F., 45
 West London Cricket Ground, 11
 West London Rowing Club, 10, 11
 Westminster School, 10
 Wharton, A., 45
 Wheeler, J., 227
 Whitaker, B. C., 64
 Wichmann, 49
 Wide, Edwin, 85, 94, 99, 100, 102, 103, 173, 174
 Willers, C. E., 93, 94
 Williams, P., 35, 49
 Williams, E. W., 187
 Willis, A. G. de L., 194
 Willoughby, H. L., 205
 Wilson, H., 137
 Winchester School, 10
 Windsor Castle, 116
 Winter, A. W., 34, 221, 222
 Winthrop, W. G., 324
 Wirath, K., 72
 Wise, B. R., 17, 18, 79, 92, 93
 Wisconsin, 107
 Women's Athletics, 4, 34
 Woodburn, E., 228
 Woodley, 229
 Wood, 123
 Wood, C. G., 45, 46
 Woods, Dr. R. S., 322, 326, 328, 329, 337. *Pl.* 58, 60, 61
 Worcester College, Oxford, 9
 Wormwood Scrubbs, 118
 Wright, M. S., 230
 Wyatt, H., 8, 9
 Wykoff, Frank, 49. *Pl.* 14
 Wynn-finch, E. 151

 Yale, University of, 20, 24
 Yamada, K., 122, 123, 126
 York, Duke of, 30
 Young, H. G., 235
 Yrjölä, J., 57, 193

 Zallhagen, O., 283, 284, 291. *Pl.* 49
 Zerling, P. G., 152

