

Birla Central Library

PILANI (Rajasthan)

Class No. 744

Book No. H682 B2 v.1

Accession No. 37586

Acc. No

ISSUE LABEL

Not later the latest date stamped below.

| | | |
|--|--|--|
| | | |
|--|--|--|

BASIC UNITS
IN
MECHANICAL DRAWING

**BOOKS BY
RANDOLPH PHILIP HOELSCHER**

PUBLISHED BY
JOHN WILEY & SONS, Inc.

WITH A. B. MAYS

Basic Units in Mechanical Drawing

Book I, Second Edition. 305 pages. 6 by 9. Cloth.

Book II. 277 pages. 6 by 9. Cloth. Both volumes profusely illustrated.

The two volumes, together, cover the field of mechanical drawing. Each book comprises a group of teaching units providing text and problem material for a year's instruction.

WITH H. H. JORDAN

Engineering Drawing

A textbook for schools and colleges, emphasizing fundamental principles and practical applications. Third edition. 835 illustrations. 528 pages. 6 by 9. Cloth.

**BOOKS BY
ARTHUR BEVERLY MAYS**

PUBLISHED BY
THE CENTURY COMPANY

The Problem of Industrial Education

An Introduction to Vocational Education

WITH S. J. VAUGHN

Content and Methods of the Industrial Arts

BASIC UNITS
IN
MECHANICAL DRAWING

BOOK I

BY

RANDOLPH PHILIP HOELSCHER

*Professor of General Engineering Drawing,
University of Illinois*

AND

ARTHUR BEVERLY MAYS

*Professor of Industrial Education,
University of Illinois*

SECOND EDITION

NEW YORK
JOHN WILEY & SONS, INC.
LONDON: CHAPMAN & HALL, LIMITED

COPYRIGHT, 1933, 1941

BY

RANDOLPH PHILIP HOELSCHER

AND

ARTHUR BEVERLY MAYS

All Rights Reserved

*This book or any part thereof must not
be reproduced in any form without
the written permission of the publisher.*

SECOND EDITION

Fourth Printing, December, 1947

Printed in U. S. A.

PREFACE TO SECOND EDITION

The original organization of this book into small learning units has been found so satisfactory that no change has been made in the organization of this edition.

The five divisions of each unit, namely (1) Purpose, (2) What You Should Know, (3) How To Do, (4) Questions, and (5) Problems, have proved their value in helping the student concentrate his attention on the new material of each unit, and no departure from this practise has been made.

Many new problems have been added to supplement those appearing in the first edition, which teachers found satisfactory in both quality and variety. Corrections have been made throughout the text, and new material has been added in Units X, XI and XXV. Map drawing has been substituted for second auxiliary projection as being more useful for general educational purposes. In keeping with the practise in other units, problems on mapping have been supplied which are not copy problems but which require solution by the student. The problems given approach practical conditions as nearly as is possible to do so in the classroom.

The authors wish to acknowledge their indebtedness to Mr. E. J. Simon, Director of Industrial Education in the Champaign City Schools of Champaign, Illinois, for many helpful suggestions, as well as to Mr. P. H. Spain of the High School of Dundee, Illinois, for similar assistance. Minor suggestions from many others have also been incorporated. To all these grateful acknowledgement is made.

R. P. HOELSCHER
A. B. MAYS

URBANA, ILLINOIS
January, 1941

PREFACE TO FIRST EDITION

This book is designed to be a real teaching aid. It is not organized as a series of conventional chapters but as a group of teaching or learning units. The units treated are those which the authors regard as basic to the field of mechanical drawing. No attempt is made to cover the entire field of drawing but only those units of instruction which are necessary to a thorough grounding in the essentials of modern drafting practise and which may be covered in one year of work. The material in each unit is so organized that a student can easily find the facts he needs in order to understand the unit and the directions telling him how to perform the operations involved. This definite separation into (1) "What You Should Know" and (2) "How To Do" is in line with the best modern practises in teaching the practical arts.

The teacher will find the text suitable for weekly classroom recitation work since the foundation is laid in each unit upon which the instructor can build some of the finer details from his own experience. On the other hand, when the teaching situation demands it, the text can be used very effectively as a tool for individual instruction owing to the fact that each unit is in reality an instruction sheet for the guidance of the pupil and not merely a discussion of the subject treated.

The questions are planned for a twofold purpose: first, for use in written quizzes, thereby giving the student an opportunity to express ideas verbally; and second, as an aid in fixing the facts in the student's mind and in stimulating thought about the material presented.

A very rich variety of problem material is offered at the end of each unit. It is not expected that any one student will be required to work all the problems, but it is hoped

that the teacher will feel that there is no lack of suitable problems from which to choose.

The book is arranged in two parts of seventeen units each. It is the belief of the authors that an abundance of teaching content for one semester's work is provided in each part. The order of arrangement of units will be found highly satisfactory, but the teacher should feel free to present the units in any order he chooses. It is hoped that teachers will find that their students early in the year are able to teach themselves many of the units by merely following the printed instructions.

This set of teaching units is designed primarily for classes in high schools and technical institutes. Flexibility and practical utility have been guiding principles of the authors. The book is planned to be used in the drafting room and not merely to be read and discussed.

The authors wish to acknowledge their indebtedness to the *American Builder and Building Age*, to Pratt & Whitney Co., and to C. F. Pease & Co., for the use of cuts which are acknowledged as they appear throughout the text.

R. P. HOELSCHER

A. B. MAYS

CONTENTS

Part I

| | |
|---|-----|
| UNIT I. Use and Care of the Pencil, Eraser, T-Square, Triangle and Scale | 1 |
| UNIT II. Lettering. Study of Letter Shapes | 18 |
| UNIT III. Use and Care of the Large Pencil Compass, Small Pencil Compass and Dividers | 29 |
| UNIT IV. Lettering. Composition | 39 |
| UNIT V. Use and Care of the Ruling Pen and Ink Compasses | 45 |
| UNIT VI. Lettering of Titles, Legends and Notes | 57 |
| UNIT VII. Orthographic Projection. Two Views, Straight-Line Objects | 62 |
| UNIT VIII. Orthographic Projection. Two Views, Curved and Hidden Lines | 73 |
| UNIT IX. Orthographic Projection. Three Views | 81 |
| UNIT X. Orthographic Projection. Reading Drawings | 89 |
| UNIT XI. Working Drawings. Mechanics of Dimensioning | 103 |
| UNIT XII. Working Drawings. Construction Dimensioning | 115 |
| UNIT XIII. Working Drawings. Construction Notes | 124 |
| UNIT XIV. Freehand Orthographic Sketching | 135 |
| UNIT XV. Freehand Pictorial Sketching | 143 |
| UNIT XVI. Tracing | 151 |
| UNIT XVII. Blueprinting | 156 |

Part II

| | |
|--|-----|
| UNIT XVIII. Geometrical Construction | 161 |
| UNIT XIX. Orthographic Projection. Reading a Drawing | 169 |

| | |
|--|-----|
| UNIT XX. Orthographic Projection. Auxiliary Views and Planes | 177 |
| UNIT XXI. Solving Problems with Auxiliary Views . | 185 |
| UNIT XXII. Auxiliary Views in Shop Drawings . . | 191 |
| UNIT XXIII. Screw Thread Forms. National Coarse and Fine Thread Standards | 198 |
| UNIT XXIV. Bolts and Nuts | 206 |
| UNIT XXV. Half and Full Sectional Views | 212 |
| UNIT XXVI. Revolved, Removed and Other Types of Sectional Views | 218 |
| UNIT XXVII. Sectioning. Standard Commercial Practise | 225 |
| UNIT XXVIII. Order of Work in Making Shop Drawings | 230 |
| UNIT XXIX. Map Drawing | 236 |
| UNIT XXX. Details of Building Construction . . . | 252 |
| UNIT XXXI. Floor Plans of Buildings | 268 |
| UNIT XXXII. Elevations and Sections of Buildings . | 283 |
| UNIT XXXIII. Pencil Tracings | 295 |
| UNIT XXXIV. Brown or Sepia Prints | 300 |

BASIC UNITS IN MECHANICAL DRAWING

PART I

UNIT I

USE AND CARE OF THE PENCIL, ERASER, T-SQUARE, TRIANGLE AND SCALE

PURPOSE OF UNIT I

The purpose of this unit is to teach the facts about pencils, erasers, T-squares, triangles and scales which one must know in order to use these instruments with understanding and skill. It is also the purpose of this unit to tell how to use such instruments and how to care for them properly.

WHAT YOU SHOULD KNOW ABOUT PENCILS, ERASERS, T-SQUARES, TRIANGLES AND SCALES

The drawing pencil. The most important working tool of the draftsman is the drawing pencil. Many of his tools are employed only occasionally, but the pencil is in almost constant use. It is, therefore, quite essential that the student of drawing be able to select the proper pencils for his use and keep them in a serviceable condition.

Grades of drawing pencils. Drawing pencils are furnished in the following seventeen grades: 6B, 5B, 4B, 3B, 2B, B, HB, F, H, 2H, 3H, 4H, 5H, 6H, 7H, 8H and 9H. These numbers and letters are stamped upon the pencil and indicate the degree of hardness of the lead, ranging from 6B, which is the softest and blackest, to 9H, which is the hardest. For mechanical drawing the 6H pencil should be used for preliminary layouts, the H or 2H for making the finished

drawing and the 2H or 3H for lettering. The softer grades are used chiefly by artists for freehand sketching.

The eraser. Three general grades of erasers may be obtained, the so-called ink eraser containing grit, the pencil eraser of firm rubber and the art gum or softer rubber for cleaning purposes. The grit eraser has no place in the drafting room for any purpose, since it destroys the surface of the paper and makes it impossible to redraw neatly over the erased area, especially with ink.

Ink as well as pencil lines can be removed effectively with a pencil eraser without damaging the surface of the paper. It should be emphasized that the eraser will remove all traces of pencil or ink, and when erasing becomes necessary, as it frequently does, the process should be continued until the paper is clean. Of course, grooves made by bearing down too hard on the pencil cannot be removed. Art gum may be used to clean an ink drawing, but its use dulls the ink lines and hence it is better to keep the paper clean than to depend upon the art gum to clean it.

It sometimes happens that by repeated erasure the surface of the paper may be somewhat roughened. This condition can be improved somewhat by rubbing the surface with a piece of soapstone or polished metal. This rubbing presses the fibers firmly together and enables one to redraw over the surface if care is exercised not to bear down too hard and tear the fibers loose.

The T-square. The T-square is used primarily to draw horizontal lines and as a support for the triangles in drawing vertical or inclined lines. The T-square should be used only for the purpose intended, never as a guide in cutting paper since the ruling edge may be marred, and never as a hammer in driving thumb tacks since the head may become loose from the blade and thus make the instrument useless. For this reason also the draftsman should be careful not to drop the T-square on the floor.

Triangles. Two triangles are in general use among draftsmen, the 30-60-degree triangle and the 45-degree triangle.

They are used, in general, to draw vertical and inclined lines. Triangles are made usually of xylonite, which is a tough, flexible, transparent material, but it can be dented, and care must be taken not to injure the edges of the triangles. Xylonite is another name for celluloid.

Both triangles and T-square should be cleaned occasionally with a damp cloth.

Scales. The objects which a draftsman or engineer has to design and describe by his drawing are seldom of such size as will permit of his drawing them in their actual dimensions upon the paper. Machines, bridges and buildings are many times the size of the largest available sheets of paper,

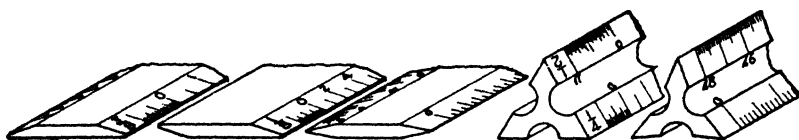

FIG. 1. Five types of scales.

hence some method of representing them accurately, but within a small space, must be used. This is accomplished by the use of various scales.

Styles of scales. Scales may be obtained in five different styles, as shown in Fig. 1. The triangular style is perhaps most common in schools since it contains the most scales. This fact, however, is sometimes a disadvantage since it causes a loss of time in keeping the proper scale in use, unless a special guard or clamp is placed upon it.

Types of scales. Three types of scales are in common use, namely, the architect's scale, the civil engineer's scale and the mechanical engineer's scale.

The architect's scale is divided so as to make possible the laying out of dimensions in feet, inches and fractions of an inch on drawings of large objects which cannot be represented full size. For example, if one desires to draw a house plan on a piece of drawing paper, it is necessary to make the drawing much smaller than the house, but it must have ex-

actly the same proportions as the house. Hence, the drawing is said to be made "to scale," that is, some "scale" such as $\frac{1}{4}'' = 1'-0''$ is used. If a closet in the house is $4'-3''$ long, the draftsman may use $\frac{1}{4}''$ to represent $1'-0''$, and he then lays out the length of his plan 4 units of $\frac{1}{4}''$ each plus 3 of the little inches to be found in the end division as shown in Fig. 2. On the architect's scale the $\frac{1}{4}''$ unit is marked off as if $\frac{1}{4}''$ were really $1'-0''$, and it is therefore divided into twelve "little inches," each one-twelfth of $\frac{1}{4}''$. In like manner, the draftsman may use $\frac{1}{8}'' = 1'-0''$, $\frac{1}{2}'' = 1'-0''$, $1'' = 1'-0''$, $1\frac{1}{2}'' = 1'-0''$, etc., depending on the number of differ-

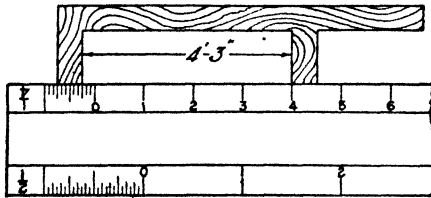

FIG. 2. Measuring with the architect's scale.

ent scales shown on the particular style of instrument he uses.

The civil engineer's scale has its units divided into tenths, twentieths, thirtieths, and so on. The complete list is shown in Table I.

The mechanical engineer's scale has its units divided into fractions of an inch. Thus a scale of $6'' = 1'-0''$ has the space representing the inch divided into eighths. A drawing made to this scale is said to be one-half size. Likewise, a drawing made to a scale of $3'' = 1'-0''$ is said to be one-fourth size. The complete list of scales is given in Table I.

HOW TO USE PENCILS, ERASERS, T-SQUARES, TRIANGLES AND SCALES

To sharpen the pencil. Sharpen the pencil on the end opposite to that on which the degree of hardness is marked, so that these marks may remain to identify the pencil as long as it is in service. Use a knife to sharpen the pencil,

TABLE I

| Architect's Scales | Mechanical Engineer's Scales | Civil Engineer's Scales |
|--------------------------|------------------------------|-------------------------|
| $\frac{3}{32}$ " = 1'-0" | $1\frac{1}{2}$ " = 1'-0" | 1" = 100'-0" |
| $\frac{1}{8}$ " = 1'-0" | 3" = 1'-0" | 1" = 80'-0" |
| $\frac{3}{16}$ " = 1'-0" | 6" = 1'-0" | 1" = 60'-0" |
| $\frac{1}{4}$ " = 1'-0" | 9" = 1'-0" | 1" = 50'-0" |
| $\frac{5}{16}$ " = 1'-0" | 12" = 1'-0" | 1" = 40'-0" |
| $\frac{3}{8}$ " = 1'-0" | 18" = 1'-0" | 1" = 30'-0" |
| $\frac{1}{2}$ " = 1'-0" | 24" = 1'-0" | 1" = 20'-0" |
| 1" = 1'-0" | | 1" = 10'-0" |
| $1\frac{1}{2}$ " = 1'-0" | | |
| 3" = 1'-0" | | |
| 12" = 1'-0" | | |

Note: These scales simply have the inch divided into the number of parts indicated. The scales are numbered 10, 20, 30, etc. Thus on the 30 scale 1" may represent 30' or 300'.

and be careful not to cut or nick the lead in removing the wood, since this weakens the lead and makes it liable to break. Leave about $\frac{3}{8}$ inch of lead exposed, and cut the wood

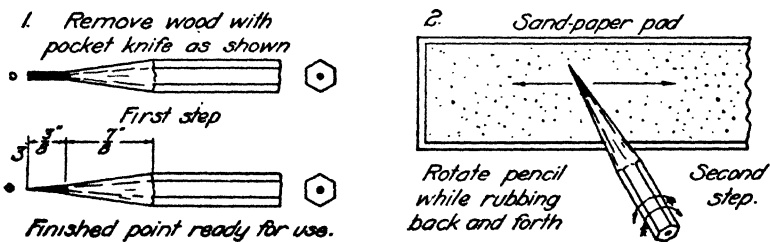

FIG. 3. Sharpening the drawing pencil.

back on a taper for $\frac{1}{8}$ inch more. Then sharpen the lead by rubbing it back and forth upon a file or pad of sandpaper. The proper shape is shown in Fig. 3. The pencil will not remain in this condition very long when being used; hence, you should keep near at hand file or sandpaper so that the lead may be frequently resharpened. A well-sharpened pencil is the first mark of a good draftsman.

To use the pencil. When ruling straight lines, hold the pencil in a plane perpendicular to the paper and incline it slightly in the direction of motion, as shown in Fig. 4. Touch the pencil gently to the paper so that it makes a light, clear mark without grooving the paper. When heavier outlines are desired, as in making a finished pencil drawing,

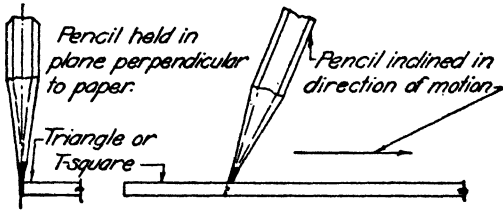

FIG. 4. Proper position for drawing pencil.

use a softer pencil. Do not try to make heavy lines by pressing down harder upon the 6H pencil. Rotate the pencil between the fingers as it is pulled along and thus prevent wearing a flat spot on one side.

To use the T-square. Hold the head of the T-square against the left edge of the drawing board by pressing the

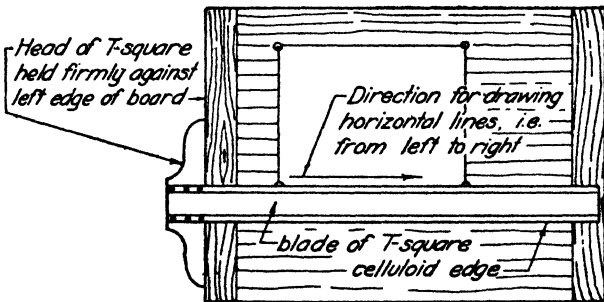

FIG. 5. Proper position of T-square.

fingers of the left hand on the blade and exerting a pull toward the right as shown in Fig. 5. Draw all horizontal lines from left to right and vertical lines from the bottom toward the top of the board. In general, the direction of motion for any line should be away from the body. Do not

try to draw vertical lines with the head of the T-square at the top or bottom of the board, because the edges of the board are not accurately at right angles to each other. Use only the upper edge of the blade as a ruling guide, because the bottom edge is not necessarily parallel to the top edge.

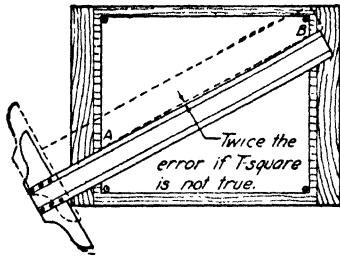

FIG. 6. How to test the T-square.

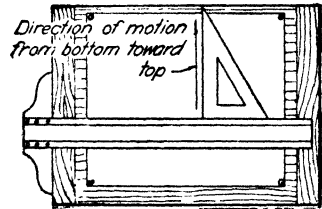

FIG. 7. Drawing vertical lines with T-square and triangles.

To test the T-square. To test the straightness of the ruling edge of the T-square, first rule a line between two fixed points. Then turn the T-square upside down and rule another line between the same two points, using the same edge as before. If the edge is true, only one line will appear, whereas if it is bowed, two lines will appear, as in Fig. 6.

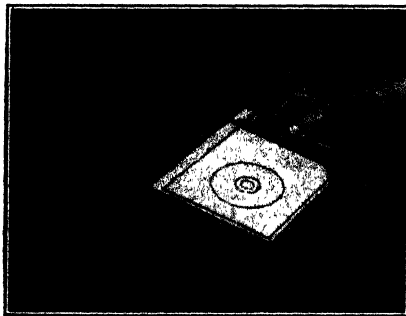

FIG. 7a. Drawing vertical lines with T-square and triangles.

If the difference between the lines halfway between the points is as much as or more than $\frac{1}{16}$ inch, the T-square should be discarded. The fixed points should be near the ends of the T-square.

How to use triangles. To draw vertical lines, place the triangle against the upper edge of the T-square and hold

it in place with the left hand, which also holds the T-square against the board. Place the thumb and palm of the hand upon the T-square and use the fingers to control the triangle. Move the pencil in the direction of the arrow as shown in Figs. 7 and 7a.

How to draw angles of 15 and 75 degrees. Place the T-square in its usual working position, then hold the 45-degree

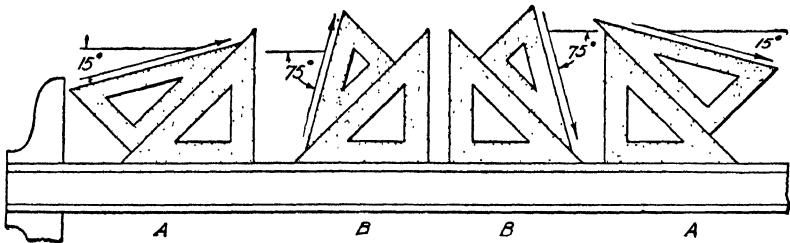

FIG. 8. How to draw angles of 15 and 75 degrees.

triangle against it, and place the 30-60-degree triangle against the 45-degree triangle as shown in A, Fig. 8. Draw along the upper edge of the 30-60-degree triangle. This line will make an angle of 15 degrees with the edge of the T-square. To draw a line making 75 degrees with the horizontal, hold the triangles as shown at B.

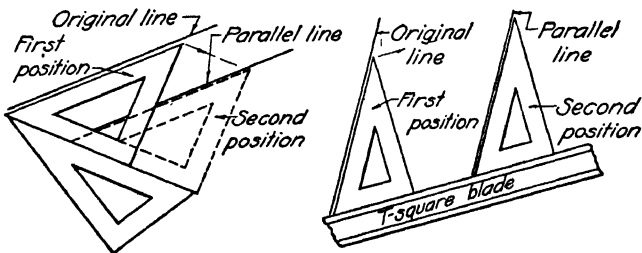

FIG. 9. How to draw parallel lines.

How to draw parallel lines. Draw a straight line in any desired direction. Bring the edge of a triangle up to the first line, and then place a second triangle in contact with the first. Slide the first triangle along the second as shown in Fig. 9 and draw the second line. It will be parallel to the

first line. The T-square also may be used as the sliding edge or support for the triangle.

How to draw lines perpendicular to each other. Draw a line in any desired direction and place a triangle along the line. Hold a second triangle or a T-square against the first triangle. Then reverse the first triangle and draw along its

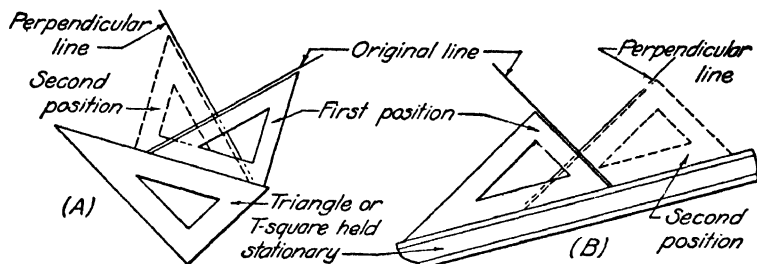

FIG. 10. How to draw perpendicular lines.

upper edge as in *A*, Fig. 10, or slide the triangle and draw a line as shown in *B*, Fig. 10. In either case, the second line drawn will be perpendicular to the first.

To test the triangle. To test the accuracy of the 90-degree angle of the triangle, draw two perpendiculars through the same point near the guiding edge of the T-square. Use the

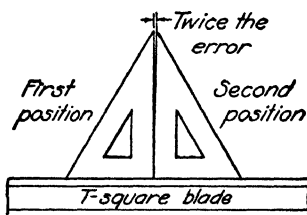

FIG. 11. How to test the triangles.

same triangle to draw both lines, placing it first in one and then in the other of the positions shown in Fig. 11. If the triangle is true, only one line will appear. If the triangle is inaccurate, two lines will appear, and the error is one-half the angle between the two lines. If this error is more than $\frac{1}{16}$ inch at the top of an 8-inch triangle, the triangle should be replaced by one that is more accurate.

To use the scale. To use the scale, one should have a very sharp pencil point to mark off the desired distance. Place the scale along the line to be measured and look down over the scale. With the pencil, mark off the dimensions wanted, being careful to place the pencil point exactly at the end of the desired mark on the scale. Hold the pencil in a vertical position.

Dividing space into odd number of parts. When it is necessary to divide a space into a given number of parts which

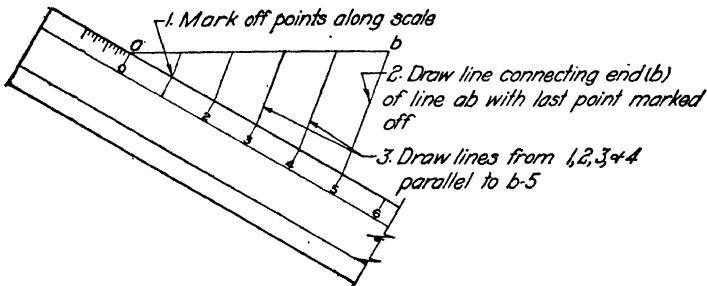

FIG. 12. Dividing a line into equal parts.

do not come out in even fractional parts of an inch, lay the scale diagonally across the space so that regular fractional parts of an inch may be used, or lay off the desired distances on some diagonal line, and then draw a series of parallel lines through the division points to the line to be divided, as shown in Fig. 12.

QUESTIONS

1. What does the letter and number on a drawing pencil, such as 2H or 3B, signify?
2. What is the mark of the softest pencil?
3. What grade of pencil is suitable for preliminary layout of a drawing or other accurate work?
4. What grade of pencil should be used for making a finished pencil drawing?
5. What grades of pencil are most suitable for lettering?
6. Make a sketch showing the proper shape of a drawing pencil point. Dimension the sketch to show the length of the lead exposed and of the wood cut.

7. Describe the proper position of the drawing pencil relative to the paper when it is being used to rule a straight line.
8. Why should not the pencil be rocked back and forth perpendicular to the straight edge as it is moved along in drawing a straight line?
9. Why should not one bear down hard on the drawing pencil in drawing preliminary layouts?
10. What is the purpose of the file or sandpaper pad in a draftsman's kit of tools?
11. What kind of an eraser should be used in removing pencil lines?
12. What is the objection to an eraser containing grit?
13. Can ink lines be removed with a pencil eraser?
14. How can the grooves made in drawing paper by bearing down too hard on the pencil be removed?
15. If the eraser does not leave the surface of the paper smooth what can be done to improve it?
16. What kind of eraser should be used to clean the drawing sheet when it is finished?
17. Against which edge of the board should the head of the T-square be placed?
18. Why should the T-square not be used with the head at the top or bottom of the board when drawing vertical lines?
19. What objection, if any, is there to using the T-square head as a hammer?
20. What is the danger involved in allowing the T-square to fall to the floor?
21. Show by a sketch and explain how the accuracy of the ruling edge of a T-square may be tested.
22. What objection is there to using both the top and bottom edges of the T-square as ruling edges?
23. Show by a sketch and explain how the accuracy of the 90-degree angle of a triangle may be tested.
24. Show by a sketch the proper way to draw one line at right angles to another by the use of two triangles.
25. Show by a sketch how to draw one line parallel to another by means of two triangles.
26. Show by a sketch how to draw an angle of 15 degrees with the horizontal up to the right using a 45- and a 30-60-degree triangle and the T-square.
27. Show by a sketch how to draw an angle of 75 degrees up to the left.
28. How are the end divisions of an architect's scale subdivided?
29. On what kind of drawings is an architect's scale used?

30. How is the civil engineer's scale subdivided, and upon what kind of drawings is it used?

31. A view of an object which measures 9"x12" must be drawn within a 3"x4" space; what standard scale comes nearest to meeting the requirements?

32. The plan of a building measures 32'-0" by 44'-0", and the plan view must be drawn within a 9"x12" space. What scale would you use?

33. Show by a sketch how to use a scale in dividing a 3-inch space into seven equal parts.

GENERAL INSTRUCTIONS FOR ALL PROBLEM SHEETS

The layouts for the border line and title space of five different standard drawing sheets are shown in Figs. 13 and

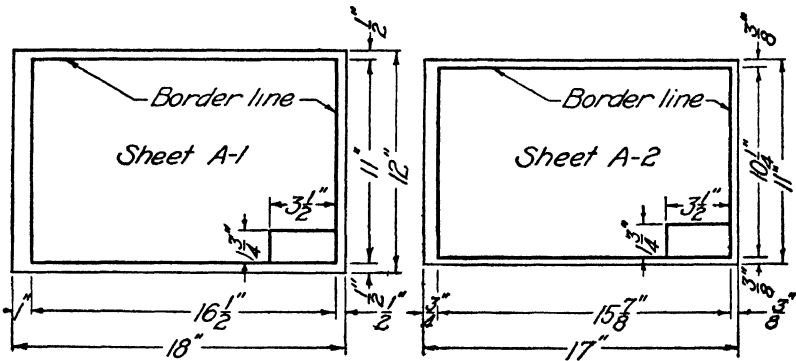

FIG. 13. Standard border line and title space for large sheets.

15. Your instructor will select the one you are to use. Study the dimensions carefully and memorize them so that you may lay out your sheets throughout the semester without continual reference to the figure.

Placing the paper on the board. The paper should be placed about 4 or 5 inches from the bottom of the board and about 3 inches from the left-hand edge, as shown in Fig. 17. Place the T-square where you want the lower edge of the paper to be, then let the paper rest upon the T-square and fasten down the upper corners with thumb tacks. As soon as you have the tacks pushed down tight, check up with your T-square to see that the lower edge of the paper

is in line. Then put the thumb tacks through the lower corners and push them all down firmly.

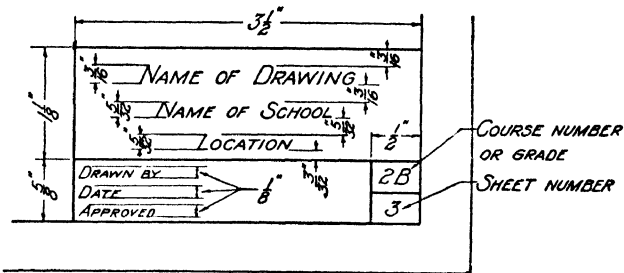

FIG. 14. Standard title form for large sheets.

Laying out the border line. Having placed the paper on the board, lay out the standard border line and title space

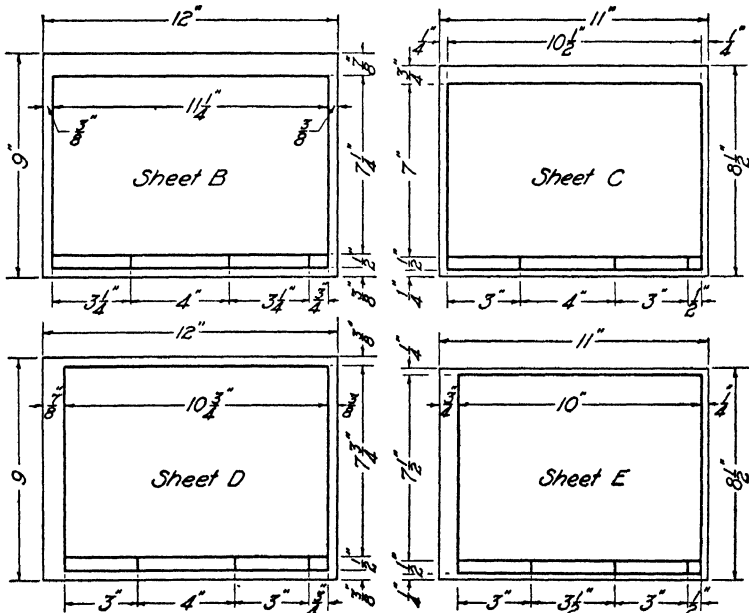

FIG. 15. Standard border lines and titles spaces for small sheets.

as selected by your instructor. Make the measurement with your scale first horizontally as shown in Fig. 17 and rule in the two vertical lines lightly with a 6H pencil. Second

make the vertical measurements and rule in the horizontal lines. Subdivide the title space as shown in Fig. 14 or 16, as the case may be.

Since the vertical lines were drawn first, these lines will over-run the corners. With your pencil eraser remove all

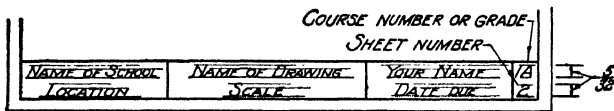

FIG. 16. Standard title forms for small sheets.

lines which extend beyond their proper limits. Now go over the entire layout with an H pencil, making the lines strong and firm but not grooving the paper. Be very careful not to over-run any of the corners. Letter in all parts of the title to the best of your ability, ruling guide lines to aid

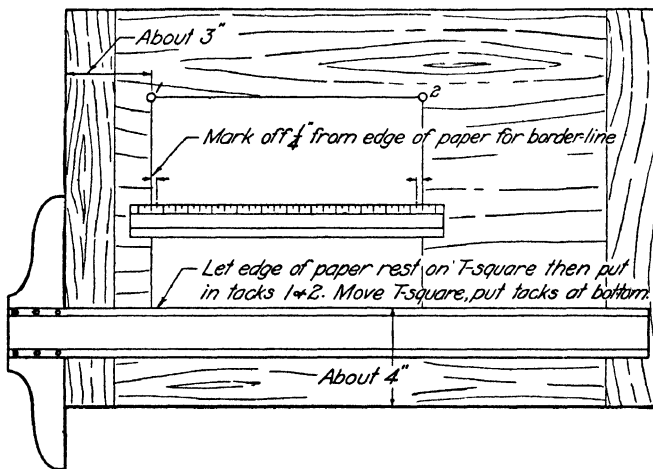

FIG. 17. Placing paper and marking border line.

you as shown in Fig. 16. The name of the drawing will be determined by the assignment of the problem which the instructor makes.

After the border line and title layout are as nearly perfect as you can make them, both as to accuracy of measure-

ment and neat appearance, proceed upon the exercises assigned by the instructor.

Note: If the drawing paper as it comes to you is a little scant of the dimensions given in Fig. 13 or 15, let this shortage appear in the space inside the border line. In other words, always keep the margin between the border line and the edge of the paper constant, since this will make the best-appearing sheet.

PROBLEMS

In the following exercises the aim should be for accuracy of measurement and drawing. Even in these first exercises no line should vary from its specified position as much as $\frac{1}{64}$ inch. The lines should be thin but firm. The enclosing rectangle should always be made first and then the pattern constructed within it. Whenever one line terminates upon another, care should be exercised to draw exactly up to the line but not over it.

Divide the space inside the border line into four equal rectangles by a horizontal and a vertical center line, then proceed to do the problems assigned. In each case the square is 3 inches on a side.

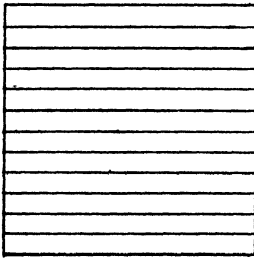

FIG. 18.

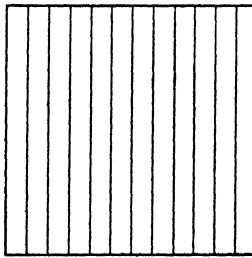

FIG. 19.

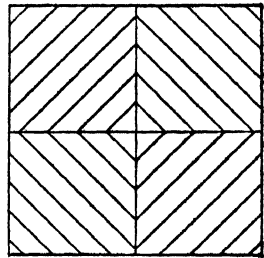

FIG. 20.

1. Draw first the enclosing square, then divide the left side into $\frac{1}{4}$ -inch divisions. From these points draw the horizontal lines, terminating them exactly upon the right side. The eraser should not be used after the enclosing square has been completed. See Fig. 18.

2. Divide the lower side of the square into $\frac{1}{4}$ -inch divisions, and from these points draw vertical lines which shall terminate exactly upon the upper side. See Fig. 19.

3. Draw the horizontal and vertical center lines of the square and then draw very lightly, so that it will hardly show, a diagonal of the square. Divide the diagonal into $\frac{1}{4}$ -inch divisions, beginning at the center of the square. Through these points draw the 45-

degree lines which terminate upon the center lines in pairs. See Fig. 20.

4. Draw the horizontal and vertical center lines of the square. Divide the horizontal center line into $\frac{1}{4}$ -inch units, and draw the 30-degree lines, terminating them exactly upon the sides and center lines as shown. See Fig. 21.

5. Divide the lower side into $\frac{1}{4}$ -inch units, and through these points draw the vertical lines first, then from alternate points on the base draw the 30-degree lines as shown. Continue the pattern to the top of the square by some scheme of your own. See Fig. 22.

Note: The three sets of lines intersect each other exactly in points on the sides and throughout the pattern.

6. Draw the diagonals of the square and divide the one running down to the right into $\frac{1}{4}$ -inch units, beginning at the center of the square. Through these points draw the 15-degree and the 75-degree lines by means of the T-square and 45-degree and 30-60-degree triangles. See Fig. 23.

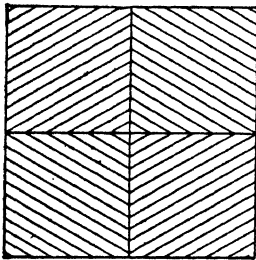

FIG. 21.

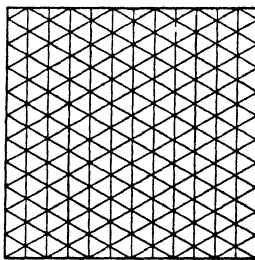

FIG. 22.

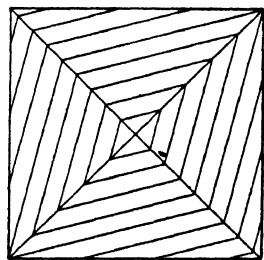

FIG. 23.

7. Draw first the circle of 3-inch diameter very lightly. Divide it into 24 equal parts by means of your triangles. The divisions of the circle are units of 15 degrees. Number the points consecutively beginning at the bottom. Connect points 1 and 8, and then proceed around the circle with the same interval until each point is connected with two others. See Fig. 24.

8. Divide the left, bottom and right sides of the square into $\frac{1}{4}$ -inch units, then connect the two upper corners with each point on the sides and bottom. In each upper corner draw an arc of $\frac{3}{8}$ -inch radius and terminate all lines upon the arc. See Fig. 25.

9. Divide the square first into $\frac{1}{2}$ -inch strips in both horizontal and vertical directions. On the left and lower lines divide each strip into $\frac{1}{8}$ -inch units and then work out the weaving pattern. The eraser is not to be used. Start and stop each line exactly upon the proper line. See Fig. 26. The patterns of Figs. 26, 27, 28 and 29 have been left incomplete to show the construction.

10. Divide the square diagonally into $\frac{1}{4}$ -inch strips in both directions. Draw these lines very lightly. Divide alternate strips, in

both directions, into $\frac{1}{16}$ -inch units, and work out the weaving pattern as shown. The three lines inside each strip should start and stop exactly at the proper point. After completing the work, go over the pattern with a softer pencil to make it stand out more clearly. See Fig. 27.

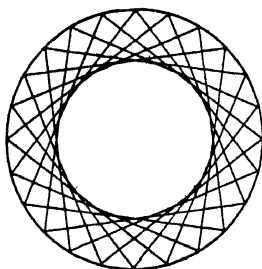

FIG. 24.

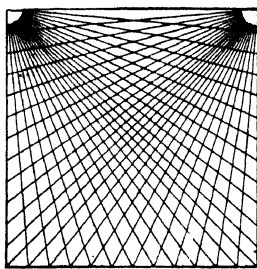

FIG. 25.

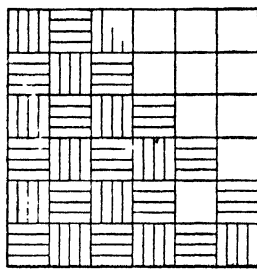

FIG. 26.

11. The weaving pattern of this problem is based upon the layout of Fig. 22, using only the alternate lines. These lines form the center lines of strips $\frac{1}{8}$ -inch wide. Draw all strips very lightly without regard to the pattern, then go over the figure with a softer pencil and work out the correct design. Do not over-run lines. Take advantage of the symmetry of the pattern in working out the design. See Fig. 28.

12. Divide the square into $\frac{1}{2}$ -inch squares by means of horizontal and vertical lines. With the center of these squares as base points, lay out $\frac{1}{2}$ -inch squares in both diagonal directions. With these lines as the center lines of strips $\frac{1}{16}$ inch wide, work out the weaving pattern shown. Follow the same procedure as in Prob. 11. See Fig. 29.

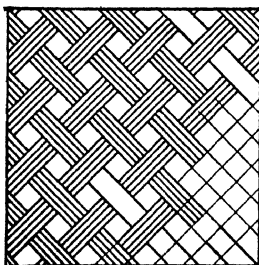

FIG. 27.

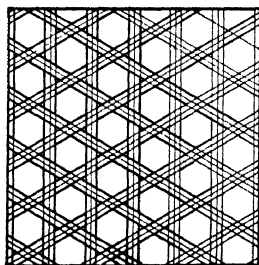

FIG. 28.

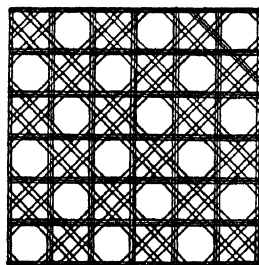

FIG. 29.

UNIT II

LETTERING. STUDY OF LETTER SHAPES

PURPOSE OF UNIT II

The purpose of this unit is to teach certain important facts about the shapes, heights, sizes, slopes and weights of letters and numbers, and to show how to make letters and numbers.

WHAT YOU SHOULD KNOW ABOUT LETTERS AND NUMBERS

Every drawing must bear a title and frequently much other lettering in the form of explanatory notes. If the lettering is poorly done, through either carelessness or ignorance, not only is the appearance of the entire drawing ruined, but because of its poor appearance its accuracy and correctness are questioned, and the maker of the drawing comes into disfavor. It is therefore important that the draftsman learn to do creditable lettering from the very beginning.

The first step in good lettering is a thorough and correct knowledge of the standard letter shapes. Such knowledge may be acquired through the study of large-size letters, the correct proportions of which are shown in the figures in this unit. The direction in which each stroke should be made is shown on each letter, and the important points of each letter are discussed in the paragraphs which follow. These should be studied carefully until each letter can be made perfectly from memory exactly as shown in the text.

Lettering should be practised with the pencil until all the letters and figures can be made correctly from memory. In addition to correct letter shapes it is necessary to observe five simple rules in order to insure success in lettering. Four of these will be given in this unit, and the fifth will be explained at a more appropriate place in Unit IV.

These rules may be summarized under the one word uni-

formity. Good lettering requires *uniformity* of *shape*, *slope*, *size* and *weight*.

Uniformity of shape. This requirement means that each time a letter is repeated in a sentence, note or paragraph, it must be like the others of its kind. Thus all the *A*'s in any piece of lettering must be exactly alike. The same thing applies to all letters and figures.

Uniformity of slope. This means that the slope of all letters must be the same. The slope of such letters as *B*, *D*, *E*, *F*, *H*, *I*, *L*, etc., is determined by the slope of the first stroke, but for letters such as *A*, *W*, *Q*, etc. the slope is determined by the axis of the letter. As an aid when beginning it is good to use slope guide lines as shown in Fig. 1. The

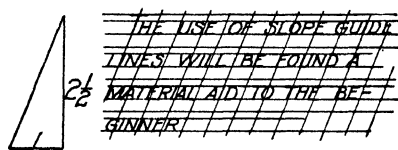

FIG. 1. Slope guide lines.

inclination of letters used by different people varies, but for good appearance a slope of two and one-half to one, as shown in Fig. 1, is recommended.

Uniformity of size. Lettering upon a drawing should never be attempted without the use of lightly ruled guide lines. As an aid to ruling such lines, several instruments are on the market, two of which are shown in Fig. 2. Guide lines for small caps are two-thirds the height of the initial caps. The lettering instruments give this spacing automatically. All letters should be made the full height of the guide lines and of uniform width as well. It is possible to make a series of letters such as *o* all of the same height but varying in width. This gives a very poor appearance and must therefore be avoided.

In addition to this general statement, a further rule should be observed; namely, such letters as *A*, *O*, *Q*, *C*, etc., which touch the guide lines at only one point should be made just a trifle higher, otherwise they appear to be smaller than

the other letters. The bottoms of all other letters as well as the tops should be brought exactly to the guide lines.

Uniformity of weight. This requirement means that all strokes of all letters in any composition must be of the same width. In pencil lettering, the first precaution required is to revolve the pencil occasionally while using it so that a broad, flat spot is not worn on the point. Second, the pencil should be frequently resharpened, taking care to maintain the same width of point at all times.

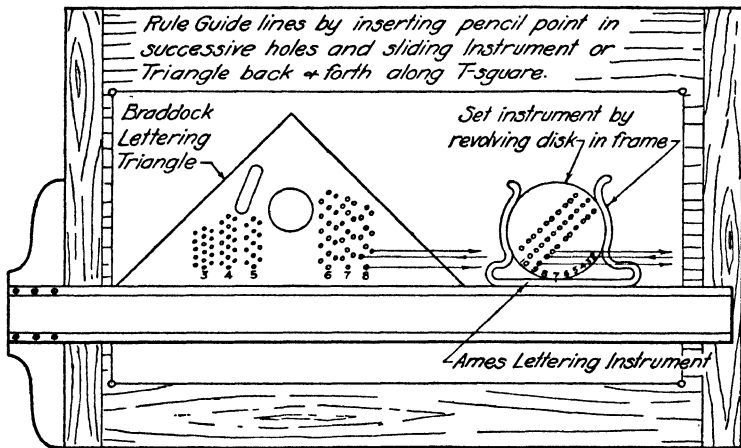

FIG. 2. Using the lettering triangle.

The method of securing a difference in the weight of strokes in inked letters is by a proper selection of pen points. A few of the pens which are on the market are shown in Fig. 3. For the usual run of drafting work the following pens will be found satisfactory, as will similar pens by other manufacturers: Tank pens No. 5, No. 12 and No. 15; Gillott No. 170, No. 303 and No. 404; Esterbrook No. 510 EF ballpointed, and Leonard No. 516 EF. The pens of larger number give the heavier strokes.

HOW TO LETTER

To draw guide lines. Place a lettering triangle or instrument against the T-square. Note the numbers at the bot-

tom of each column of holes indicating the height of the guide lines in thirty-seconds of an inch. The Ames lettering instrument is likewise numbered to give letter heights in thirty-seconds of an inch. After you decide on the height

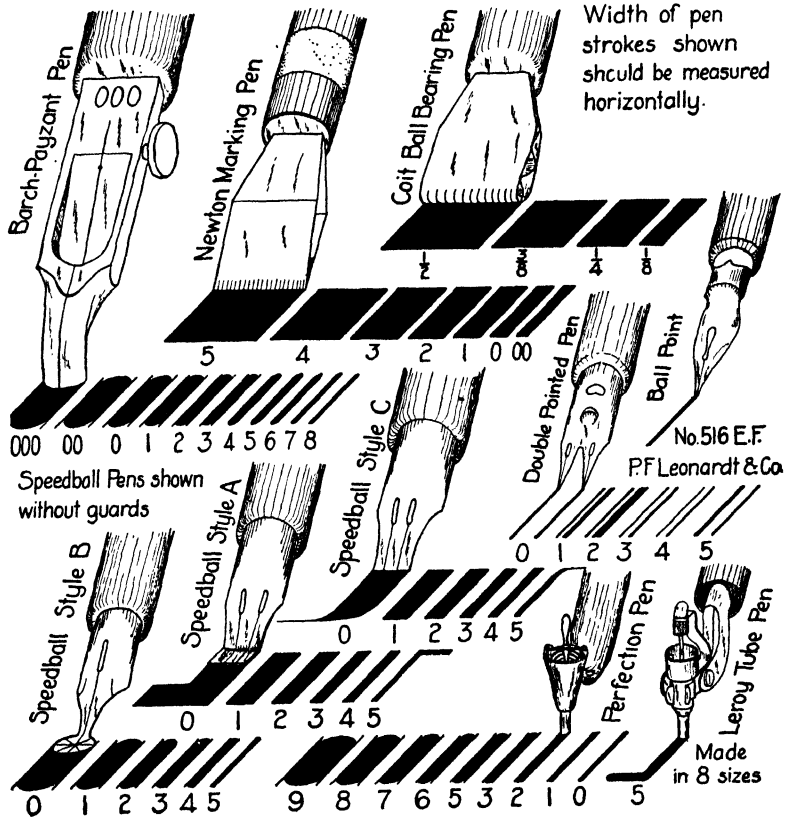

FIG. 3. Lettering pens.

of the letters, insert the pencil in the holes in the column which gives the height of guide lines you desire and slide the triangle, or Ames lettering instrument, back and forth along the T-square as shown in Fig. 2. When more than one line of lettering is required, the holes in these instruments give the proper spacing between lines.

How to make *I, L, T, H, F* and *E*. The six letters in Fig. 4 are composed entirely of horizontal and sloping straight strokes. Practise these strokes separately, before combining them in letters, until you can make them smoothly and accurately. Notice the proportions of the letters and the directions in which the strokes should be made. Make the horizontal strokes near the center of the last three letters just a little above the middle. Draw the bottom stroke of the letter *E* just a little longer than the upper horizontal stroke. Make the main strokes of the letters *I, L, T, H, F* and *E* follow the slope of the slope guide lines. The width of all letters except *W* is about five-sixths the height.

How to make *A, V, W* and *M*. In the group shown in Fig. 5, make the center line of the letter follow the slope

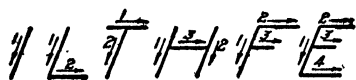

FIG. 4.



FIG. 5.

guide lines as shown. The slope line through the center should bisect the base of the letter *A* and the top of the other letters. After a little practise with slope lines through the center of the letters make the letters without drawing center lines. You can then keep the correct slope by making the second stroke of the letter *A* and the corresponding strokes in other letters perpendicular to the guide lines as shown in Fig. 5. Make the first and third strokes of the letter *W* parallel to each other; also make the second and fourth parallel. Always draw the outside strokes of the letter *M* parallel.

How to make *K, N, X, Y* and *Z*. Notice the wider variety of combinations in the third group of straight-stroke letters shown in Fig. 6. Begin the second stroke of the letter *K* just inside the enclosing parallelogram of guide lines and intersect the first stroke at about one-third its height from the bottom. Begin the third stroke at the corner of the parallelogram and draw it so that if it were produced it

would pass through the opposite diagonal corner, as indicated by the dotted line. Draw the first strokes of the *X* and *Y* as diagonals of the parallelogram of guide lines, beginning at the top just a little in from the corner. Place the intersection of the lines in the *X* a little above the center, and that of the *Y* a little below the center. Make the top stroke of the *Z* shorter than the bottom stroke.

How to make O, Q, C, G and S. Notice that the letter *O* forms the basis of all five letters shown in Fig. 7, and for parts of the letters in Fig. 8. Make this oval tangent to the mid-points of the sides of the enclosing parallelogram of guide lines. Practise this letter until you can make it perfectly before you attempt making the others in this group. Place the dash in the letter *Q* so that it passes through the

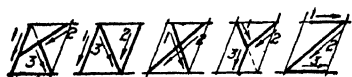

FIG. 6.



FIG. 7.

corner of the enclosing parallelogram of guide lines in the direction of the diagonal of the parallelogram. Make the openings in the letters *C* and *G* at approximately the center third of the right side of the oval. Draw the horizontal bar in the *G* about one-third of the way across the letter. Make the upper part of the letter *S* smaller than the lower part, and think of the entire letter as being formed within the basic oval of this group, as indicated in Fig. 7.

How to make D, B, P, R, J and U. Notice that the six letters shown in Fig. 8 are composed of combinations of straight strokes and ovals. Be careful to make the horizontal strokes in the first four letters perfectly straight for one-half the width of the letter. From that point begin the oval. Make the bottoms of the *J* and *U* also as parts of the oval. Make the sloping strokes in these letters perfectly straight until they become tangent to the oval. Draw the center stroke in the letter *B* slightly above the center, but place the middle stroke in the letters *P* and *R* at the center.

How to make numbers. Examine carefully the proper shapes of the numbers and the directions of strokes to be used in making them as indicated in Fig. 9. Make the tops of the 2, 3 and 6 not quite so wide as the bottom parts. Form the 6, 8 and 9 and the bottom parts of the 3 and 5 as if they were parts of the oval which forms the zero. Notice that this oval is considerably narrower than the one

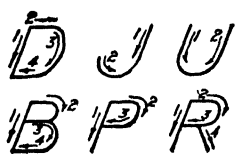

FIG. 8.

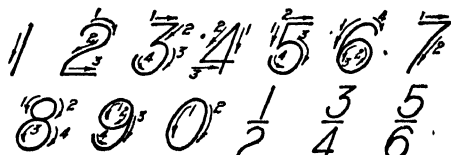

FIG. 9.

forming the letter O. Place the cross-bar of the 4 one-third the height of the number from the bottom. Make the bottoms of the 3, 5 and 6 similar in size and shape to the bottom of the 8.

How to letter fractions and mixed numbers. Make numerals, when representing whole numbers, the same size as the initial capital letters. Make the numbers in fractions,

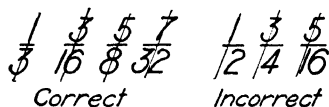

FIG. 10.

however, only two-thirds as high as the initial capitals, or whole numbers, or exactly as high as the small capitals. When a fraction accompanies a whole number, make the numerals in the fraction extend above and below the whole number. Always draw the cross-bar in the fraction, which separates the numerator from the denominator, horizontally, as shown in Fig. 9. Place the numerator and denominator so that the same slope line passes through their centers and not so that they will be offset from each other. Notice the correct and incorrect examples shown in Fig. 10.

How to letter in ink. When lettering in ink, follow these suggestions carefully:

1. See that the paper is free from all dust, dirt and lint which the pen might accidentally pick up.

2. See that the pen is not filled too full, and do not continue to use until it is dry. Fill frequently, and clean often.

3. Bear down just hard enough for the pen to produce its normal stroke. Do not spread the nibs of the pen.

QUESTIONS

1. Make a letter designated by the instructor. The letter shall be $\frac{3}{4}$ inch high. Show on it the slope line, the direction in which the strokes are made, and discuss the outstanding characteristic of the letter.
2. What is the proper relationship between the height of the capitals and the other letters?
3. Letter the entire alphabet.
4. Letter all the numerals and make several fractions.
5. What is the relative height of numerals in fractions as compared to whole numbers?
6. Should the bar in fractions be drawn horizontally or inclined?
7. Show by a sketch the proper slope for letters. Give dimensions.
8. Under what one word can the four rules for good lettering be summarized?
9. State the four requisites of good lettering.
10. What is meant by uniformity of shape?
11. What is meant by uniformity of size? Explain and illustrate by correct and incorrect examples. Designate each kind.
12. What is meant by uniformity of slope in lettering?
13. What is meant by uniformity of weight? What precautions must be taken to attain it when lettering with a pencil?
14. When lettering with pen and ink, what precautions must be taken to attain uniformity of weight in all strokes?
15. Illustrate the proper placing of numerals in a fraction as regards the slope line.
16. When can one dispense with guide lines in lettering a drawing?
17. What is the danger in hurried lettering practise in which letter shapes are incorrectly made?
18. What is the meaning of the number under each column of holes on the Braddock lettering triangle?

19. How may the slope guide for letters be drawn with the Ames lettering instrument?
20. When more than one line of lettering is to be made, how can the successive sets of guide lines be spaced with the lettering triangle or Ames instrument?
21. When letters of considerable difference in weight are to be made, how is this best accomplished?

PROBLEMS

In laying out the sheet for exercises in this unit, draw first the standard border line and title space, then divide the space inside the border into four equal rectangles by means of a horizontal and a vertical center line. In each space, rule guide lines for letters $\frac{1}{4}$ inch high. Begin the top of the first set of lines $\frac{3}{8}$ inch from the border line, and rule seven sets of lines as shown in Fig. 11. Draw

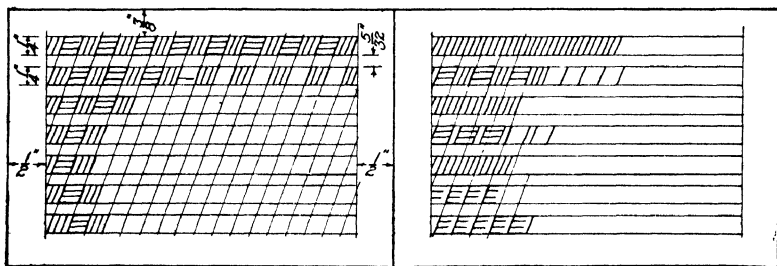

FIG. 11.

FIG. 12.

vertical margin lines $\frac{1}{2}$ inch from the sides of each rectangle and keep all lettering work inside these lines. Use a 4H pencil for ruling the guide lines.

Note: If lettering triangles are not available, space sets of guide lines $\frac{1}{8}$ inch apart.

Do the exercises as assigned by the instructor. The title of the sheet will be **LETTERING**.

Lettering exercises should always be done carefully. Attention should be focused at first upon producing perfect letters. Then, as facility is gained, greater speed in making perfect letters should be the goal. The beginner should make about 12 to 15 good letters per minute and endeavor to increase his speed up to about 30 perfect letters per minute as a maximum.

1. Having ruled the horizontal guide lines, draw slope guide lines $\frac{1}{4}$ inch apart across the lettering area, thus dividing the space into $\frac{1}{4}$ -inch parallelograms. In alternate parallelograms draw sloping lines freehand, as shown in Fig. 11. Then draw the horizontal lines freehand, completing each line before beginning the next. Endeavor to draw smooth, uniformly spaced straight lines.

2. Measure off on the top line of the upper set of guide lines 1 inch of $\frac{1}{4}$ -inch spaces as shown in Fig. 12. Draw sloping strokes dividing the space between these points into three equal parts. Begin and end exactly on the guide lines. Continue the strokes, spacing the remainder of the line by eye. Divide the second line into $\frac{1}{4}$ -inch spaces for the first inch and one-half. Then draw hori-

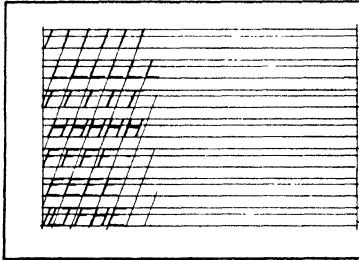

FIG. 13.

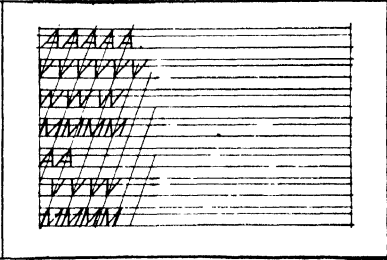

FIG. 14.

zontal and sloping lines in alternate spaces as shown. Continue the spacing by eye. Complete the exercise as shown in the figure. Accuracy in starting and stopping strokes at the proper place together with accuracy of spacing should be the chief aim.

3. Practise the letters of group 1 as shown in Fig. 13. Space the letters about $\frac{5}{16}$ inch center to center, except in the last row, where the letters *I*, *L* and *T* are to be made closer together.

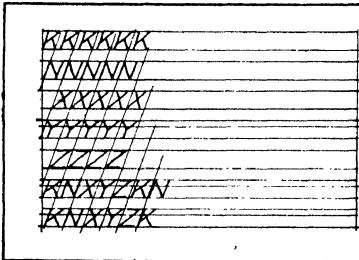

FIG. 15.

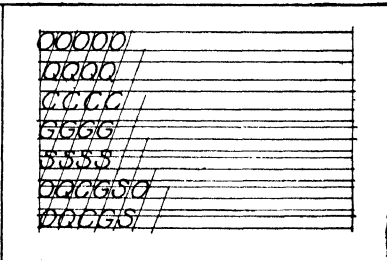

FIG. 16.

4. Practise the letters of group 2. Draw first the slope guides for the first five or six letters *A* and *V* about $\frac{5}{16}$ inch apart, and then construct the letter about this line as shown in Fig. 14. Complete the practise for the remainder of each line without the slope lines. The letters *W* and *M* are to be made directly without the aid of sloping center lines.

5. Practise the letters of group 3. Draw the enclosing parallelogram for the first few letters in each line as a guide, as shown in Fig. 15, then continue the remainder of each line without the parallelogram.

6. Practise the letters of group 4 as shown in Fig. 16. Proceed as in Prob. 5. Study the letters carefully as you make them and correct the faults as you go along.

7. Practise the letters of group 5 as shown in Fig. 17. Proceed as in Prob. 5.

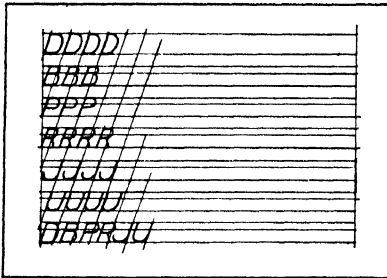

FIG. 17.

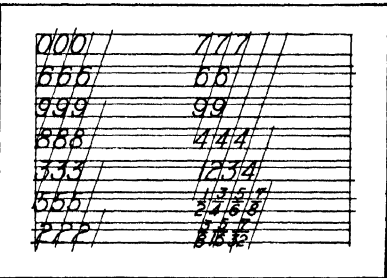

FIG. 18.

8. Practise the numerals as shown in Fig. 18. Proceed as in Prob. 5. Note that the parallelogram for the zero is much narrower than for the letter *O*. In the first practise, additional guide lines may be ruled for the fractions.

Repeat the various problems or specialize upon the letters with which most difficulty is experienced, as directed by the instructor, until creditable lettering is achieved.

UNIT III

USE AND CARE OF THE LARGE PENCIL COMPASS, SMALL PENCIL COMPASS AND DIVIDERS

PURPOSE OF UNIT III

It is the purpose of this unit to teach the use and care of the compasses and dividers, and to show how to make certain geometric constructions which are used in mechanical drawing and which require the use of compasses and dividers.

WHAT YOU SHOULD KNOW ABOUT COMPASSES AND DIVIDERS

The compasses, both large and small, are used for drawing circles and arcs of circles. The small compass, generally called a bow compass, is used for the smaller circles usually up to about $1\frac{1}{4}$ inches in radius. The large compass is used from the limit of the small compass up to circles having a radius of about 7 inches. For circles larger than this an extension bar must be used. This device will permit a maximum radius of about 11 inches.

Either a conical or a bevel point may be used on the lead of the large compass. The lead should be about $\frac{1}{32}$ inch shorter than the needle point as shown in Fig. 1. Thus when the needle point sinks slightly into the paper the lead point comes into contact with the paper and the circle can then be drawn without causing the needle point to slip, as frequently happens in drawing small circles if the lead is too long.

For the small compass the lead should be sharpened to a bevel point, and it should be inserted in the compass with the bevel face turned away from the needle point as shown in Fig. 1. This will enable the draftsman to make smaller circles than could be made with the conical point or with

the bevel face turned in, since in many types of instruments the clamping screws on both legs prevent closing the instrument as far as is sometimes desired. For very small circles, say of $\frac{1}{8}$ -inch radius or less, the needle point should be only about $\frac{1}{64}$ inch longer than the lead to secure good results without punching a large hole in the paper.

The dividers are used for transferring measurements from one part of a drawing to another and also to step off a series of two or more equal spaces along a line either curved or straight. When the dividers are not in use, they should be carefully laid aside so as to protect the sharp points.

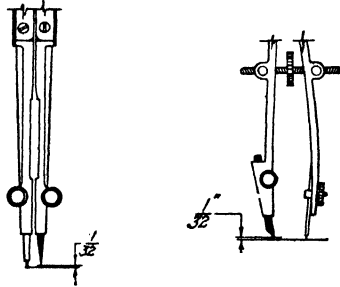

FIG. 1. Adjustment of pencil point in compass.

Do not jab the points of the dividers into the drawing board even temporarily, since the points may become broken, and they are difficult to resharpen or replace. Drawing tools are fine instruments and should always be treated as such.

HOW TO USE COMPASSES AND DIVIDERS

To use the large compass. The needle point of the compass should not be pushed through the paper, although where many concentric circles are to be drawn this cannot be entirely avoided. It is, however, unnecessary to make large unsightly holes at the center of any circle or series of circles. This can be prevented by causing the needle point to sink into the paper only enough to take hold. Tilting the compass too far in the direction of motion as it is revolved has a tendency to enlarge the hole once the needle point

has passed through the paper. It is therefore best to keep the compass in a plane almost perpendicular to the plane of the paper.

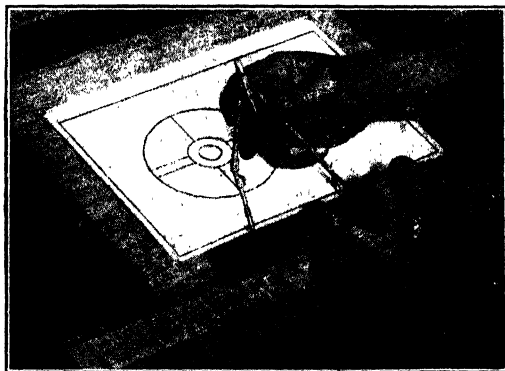

FIG. 2. Setting the compass.

For good work, the joints of the compass must be kept rather stiff so that they will not spread while drawing a circle. To set the compass to some specified dimension hold



FIG. 3. Another way to set the compass.

it as shown in Fig. 2. If the joints are very stiff, use both hands to make the final accurate setting, as shown in Fig. 3.

If the compass is equipped with a hair-spring adjustment, make the first setting to within $\frac{1}{32}$ inch of the correct di-

mension, and make the final accurate setting by turning the thumb screw on the hair spring. The hair-spring adjustment usually allows a movement of about $\frac{1}{8}$ inch at the needle point. The cheaper sets of drawing instruments do not have this adjustment.

To draw a circle, bend the legs of the compass so that both the pencil point and the needle point are approximately perpendicular to the paper. After the correct setting has been made, grasp the top of the compass between the thumb and forefinger and revolve in a clockwise direction as shown in Fig. 4.

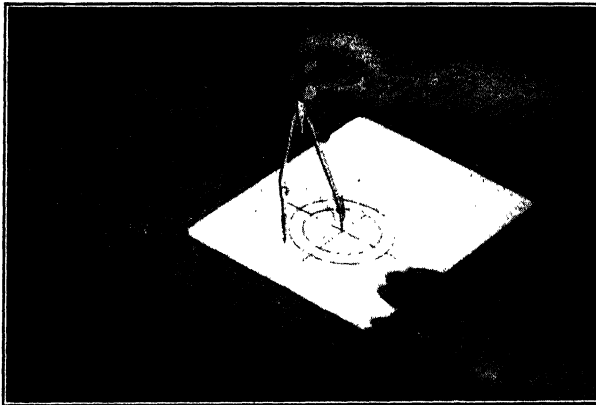

FIG. 4. Drawing a circle.

To use the bow compass. Set the small compass to any desired dimension by means of the thumb-screw adjustment. To draw a circle, revolve the compass between the thumb and forefinger in the same manner as the large compass.

To use the dividers. The setting of both large and small dividers to any desired distance is made in the same way as previously described for the large and small compass. In stepping off distances be careful not to punch holes in the paper, but make very slight indentations and immediately mark them by dotting with a sharp pencil point. In this way you will preserve the measurements without marring the paper. In stepping off a number of equal spaces

turn the dividers in one direction for the first step and then in the opposite direction for the next, and so on.

To draw tangent circles and arcs. In drawing arcs of circles which are tangent to other lines, make these lines coincide exactly at the point of tangency. It is necessary to locate the center of the arc by a geometrical construction and to exercise certain other precautions as well. After having located the center geometrically, rest the needle point of the compass at this center and swing the compass over the line, but without touching the paper, to see if it will be exactly tangent. If it is not, adjust the compass, or shift the location of the center until exact tangency has been secured, then push the needle point lightly into the paper and draw the arc. This precaution takes but a moment and it is only by this method that smooth and accurate work can be attained. Under no circumstances should the arc be drawn past the point of tangency, which, in the case of a straight line, is on the perpendicular to the line through the center of the arc.

IMPORTANT GEOMETRICAL CONSTRUCTIONS

The following fundamental constructions are frequently used and should be thoroughly learned so that they may be used in drawing, without special effort.

1. **To draw a circle of a given radius r tangent to a straight line at a given point.** The center of any circle of radius r tangent to a line AB is on a straight line parallel to AB a distance r from it. The center of a circle tangent to a right line at a given point is also on a perpendicular to the line at that point. Hence the center of the circle is at the intersection of these two lines, as shown in Fig. 5.

2. **To draw a circle of radius r tangent to two intersecting straight lines AB and CD .** As in the construction above, the center of a circle of radius r tangent to a line AB is on a line parallel to it and r distance from AB . The same may be said for CD ; hence the center of the circle is at the intersection of these two lines, as shown in Fig. 6. The center

is also on the bisector of the angle between the lines, but the bisector is not used in this construction.

3. **To bisect a given line.** From the end A of the given line, draw arcs 1 and 2 of any convenient radius r , and from end B arcs 3 and 4 of the same radius, as shown in Fig. 7. Join the two points of intersection of the arcs. This line bisects the given line.

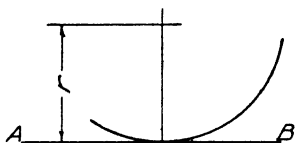

FIG. 5. Circle tangent to line.

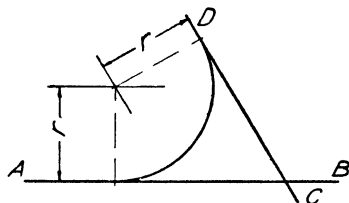

FIG. 6. Circle tangent to two lines.

4. **To bisect a given angle.** With the vertex A of the angle as a center, draw arc 1 cutting both sides of the angle at B and C as shown in Fig. 8. With these two points as centers, and any convenient radius, draw arcs 2 and 3. A line through the vertex and the intersection of these arcs bisects the angle.

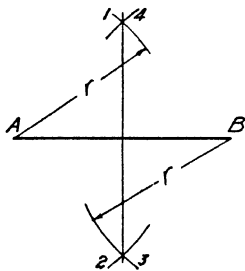

FIG. 7. Bisecting a line.

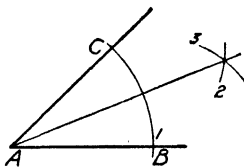

FIG. 8. Bisecting an angle.

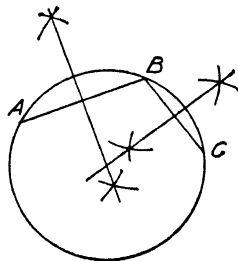

FIG. 9. Circle through three points.

5. **To draw a circle through three points** (not collinear). The center of the circle will be equidistant from the three points. Any point on the perpendicular bisector of a line is equidistant from the ends of the line. If therefore we erect perpendicular bisectors of the two lines joining the three

points, the intersection of these bisectors locates the center of the circle. See Fig. 9.

6. **To circumscribe a circle about a triangle.** This is an application of Prob. 5, and the solution is left to the student.

7. **To locate the center of a given circle.** This is also an application of Prob. 5, and the solution is left to the student.

8. **To bisect an arc.** With the end A of the arc as a center and any convenient radius greater than one-half the arc, describe two arcs. Then with the end B as a center, and the same radius, describe two other arcs. A straight line through the intersections of these arcs bisects the arc. See Fig. 10.

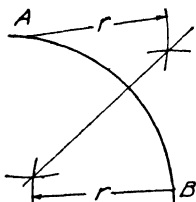

FIG. 10. Bisecting an arc.

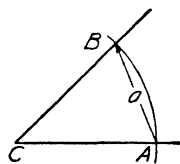
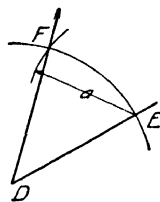

FIG. 11. Reproducing a given angle.



9. **To reproduce a given angle.** With the vertex of the angle as a center, draw an arc cutting both legs of the angle at A and B as shown in Fig. 11. At the desired place on the drawing paper, draw a straight line of random length. Then with any point such as D on this line as a center, draw an arc of the same radius as the one above, cutting the line at E . On the original angle set the compass to the distance AB ; then, with the point E as a center and with the radius just obtained, draw an arc cutting the first arc at F . The line DF completes the angle which is equal to the original angle.

10. **To erect a perpendicular to a line at any point within the line.** With the given point A as a center, describe an arc cutting the line at B and C . With any convenient radius (greater than AB) draw arcs 1 and 2 with centers at B and

C respectively. A line through the intersection of these arcs and the point A is the required perpendicular. See Fig. 12.

11. **To erect a perpendicular to a line at the end of the line.** At any convenient point A (not on the line) as a center, draw an arc passing through the end point B and cutting the line again at C as shown in Fig. 13. Draw a line through A and C and extend it until it cuts the arc at D . The line joining B and D is the required perpendicular. Upon what proposition in geometry does this construction depend?

12. **To construct a triangle when the lengths of the three sides are given.** Lay off the longest side at the desired place on the sheet. With the length of another side as a radius

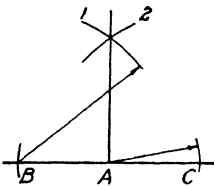

FIG. 12. Perpendicular to a line.

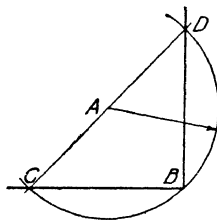

FIG. 13. Perpendicular at end of line.

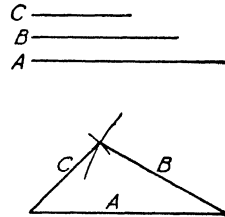

FIG. 14. Constructing a triangle.

describe an arc having one end of the long line as a center. Then, with a radius equal to the remaining side of the triangle and the other end of the long side as a center, describe a second arc which will cut the first one. Joining the intersection of these arcs with the ends of the long line completes the triangle. See Fig. 14.

QUESTIONS

1. What should be the difference in length of the needle point and pencil point in the large compass?
2. Why should the needle point be kept perpendicular to the paper?
3. What is the purpose of the hair-spring adjustment on the large compass?
4. How should the lead in the small compass be sharpened?
5. In what position should the bevel face of the lead point be turned relative to the needle point of the small compass? Why?

6. What precautions may be taken to avoid having a large hole at the center of a series of concentric circles?
7. In marking off distances with dividers, why is it best not to punch holes in the paper?
8. How may the measurements made with dividers be made permanent if holes are not punched through the paper?
9. Explain how to locate the center of an arc tangent to two intersecting right lines.
10. What precautions must be taken to secure exact tangency in drawing an arc tangent to a line after the center has been located by geometrical construction?
11. In drawing an arc tangent to one or more lines, why cannot the center obtained by geometric construction be absolutely relied upon to give the exact center of the arc?
12. Where should the arc be stopped in drawing an arc tangent to a straight line? Illustrate by a sketch.
13. What is the maximum radius to which your large compass can reasonably be set?
14. What is the purpose of the extension bar supplied with drawing sets?
15. Show by a sketch and explain how to draw a circle tangent to a given right line at a given point.
16. Explain how to draw a circle through three points. Illustrate with a freehand sketch.
17. Explain how to locate the center of an arc or circle when the center is not shown. Illustrate with a freehand sketch.
18. Explain how to construct an angle equal to a given angle. Illustrate with a sketch.
19. Explain how to erect a perpendicular at the end of a given right line. Illustrate with a sketch.

PROBLEMS

Accuracy of construction is the principal objective of the work in this unit. Accurate work cannot be done with a blunt pencil point. See to it, therefore, that your pencil point is long and sharply pointed. Hold the pencil nearly perpendicular to the paper so that the thin point may not be broken. Draw light hair lines in making your preliminary construction, and remember that only with the greatest care can absolute accuracy be attained.

After drawing the standard border line and title space, divide the sheet into four equal rectangles by means of horizontal and vertical center lines. Do the problems assigned by the instructor. Do not erase the geometrical construction.

1. Draw a line $2\frac{1}{8}$ inch long and bisect it.
2. Draw an angle of 30 degrees and bisect it.
3. Draw an arc of 3-inch radius subtending an angle of 60 degrees and then bisect the arc.
4. Construct a triangle having sides $1\frac{1}{2}$, 2 and $2\frac{1}{2}$ inches long.
5. Draw a line $3\frac{1}{2}$ inches long and then draw a circle of $1\frac{1}{2}$ -inch radius tangent to it at a point 2 inches from the end.
6. Draw an angle of 45 degrees and then draw an arc of 1-inch radius tangent to the sides of the angle.
7. Draw a line $2\frac{3}{4}$ inches long and erect a perpendicular at one end of it.
8. Draw an angle of 75 degrees, using your triangles, and then reproduce this angle by geometrical construction.
9. Construct a scalene triangle having sides $1\frac{3}{4}$, $2\frac{1}{2}$ and 3 inches long, and then circumscribe a circle about the triangle, i.e., draw a circle which passes through the vertices of the three angles.
10. Reproduce full size the assigned diagrams from Figs. 15 to 20.

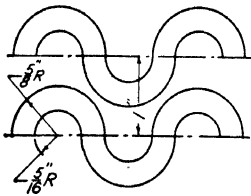

FIG. 15.

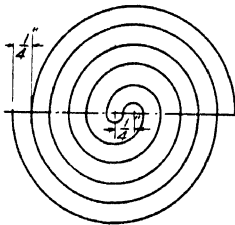

FIG. 16.

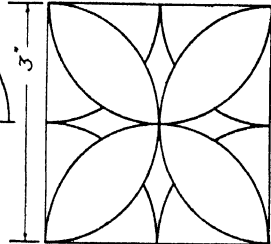

FIG. 17.

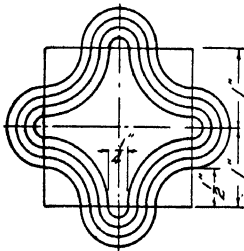

FIG. 18.

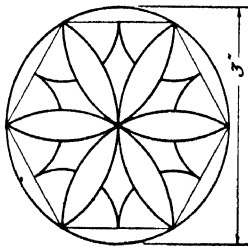

FIG. 19.

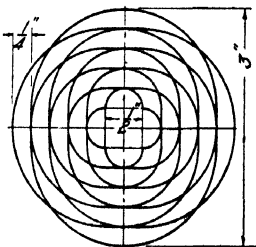

FIG. 20.

UNIT IV

LETTERING. COMPOSITION

PURPOSE OF UNIT IV

The purpose of this unit is to give further information about lettering, to show how properly to space letters, words and sentences, and to provide exercise problems in lettering.

WHAT YOU SHOULD KNOW ABOUT LETTER SPACING

In lettering upon drawings, not only must the letters of the alphabet be made correctly but also they must be combined into words, sentences and paragraphs in a pleasing manner. To achieve this result requires the careful observance of the four rules studied in Unit II, namely, *uniformity of shape, size, slope and weight*, and also the fifth rule, which requires *uniformity of spacing*.

Uniformity of spacing. This rule means that the letters in a word must be so placed that the white areas between letters appear to be uniformly equal, and, second, that the spaces between words be somewhat larger than those between letters, and also uniformly equal between all words. This can be most satisfactorily accomplished simply by judgment and a little forethought rather than by any attempt at measurement. Practise, of course, is necessary.

Forethought is required because the area between certain letters cannot be brought below a definite minimum, whereas the area between other letters can be made of almost any amount. For example, if the letters *L* and *A* fall next to each other, as in the word *LATE*, the area between the *L* and *A* cannot be reduced below the amount existing when the letters just touch. Other combinations such as *TT*, *XX*, *TY* and *FT* likewise have a definite limit to the minimum area between the stems of the letters. On the other

hand, such letters as *I*, *H*, *N*, *M*, *U*, etc., can have their stems placed as close together as one pleases. Care must therefore be exercised to see that such letters are not placed so close together that the spacing makes a disagreeable contrast with that between other pairs of letters such as *TT*, *AA*, *TY*, *LT*, etc. The word *Illinois* is an example of what may occur if the letterer is not careful to make the spacing uniform. See Fig. 1.

ILLINOIS ILLINOIS RELIEF VALVE RELIEF VALVE
INCORRECT CORRECT INCORRECT CORRECT

FIG. 1. Spacing of letters.

Compact lettering. The rule discussed above may be carefully followed and yet the lettering may not be pleasing or easy to read unless the letters are compactly spaced. This means that the letters in a word must not only be uniformly spaced but they must also be kept close enough together for the eye to grasp the entire word as a unit, rather than as a series of separate letters. Compact spacing has a double advantage in that it is easier to read and moreover the small irregularities in individual letters do not stand out in

*OPEN SPACING MAKES LETTERING
 HARD TO READ.*

COMPACT SPACING MAKES EACH WORD A UNIT.

FIG. 2. Advantage of compact spacing.

such glaring fashion as they do when the letters are too widely separated. Figure 2 gives correct and incorrect examples.

The spacing between words should be about equal to the width of the letter *M*, and the spacing between sentences should be a little greater than *M*.

In the discussion thus far, the letters have been considered to be of a certain standard width as given in Unit II, namely, about five-sixths the height. This width is the one generally used when there is no limitation upon the space

which may be used for lettering. Such letters are referred to as normal letters.

It sometimes happens, however, that certain lettering must be placed within a very limited area. If the normal letters were used this could not be done. The desired result is achieved by compressing the letters, the spacing between letters and the spacing between sentences all in the same proportion. Such letters are referred to as compressed letters; they are illustrated in Fig. 3.

EXPANDED LETTERING
COMPRESSED LETTERING

FIG. 3. Expanded and compressed lettering.

It also sometimes happens that it may be desirable to extend certain lettering over more than the normal amount of space. This need gives rise to the so-called expanded letters, which are also illustrated in Fig. 3. It should be noted that the space between letters in expanded lettering is not increased in proportion with the letters since this would not improve the appearance and would make the lettering harder to read.

QUESTIONS

1. Name briefly the five requisites of good lettering.
2. Explain what is meant by uniformity of spacing. Use a figure to illustrate your statement.
3. By what method is uniformity of spacing achieved?
4. Can all letters be spaced so as to have any desired area between them? Illustrate your answer with examples.
5. Which gives the more pleasing and legible lettering, compact or open spacing?
6. What are the advantages of compact spacing?
7. What are the disadvantages of open spacing?
8. Approximately what space should be left between words?
9. What is meant by normal letters?
10. Explain clearly what is meant by compressed letters. Illustrate.
11. Under what condition may compressed lettering be used?
12. What is meant by expanded lettering? When may it be used?

13. Should the space between letters in expanded lettering be increased in proportion to the increase in width of the letters?

PROBLEMS

Good lettering, like any other expression of manual skill, such as playing a musical instrument, typing, playing baseball or tennis, requires not only the experience obtained by many trials, but also frequent practise after skill has been acquired, in order to keep in form.

The exercises of this unit and of Unit II should, therefore, be practised and studied until a high standard of skill is achieved. Thereafter practise lettering once or twice a week whether your teacher assigns it or not, being careful to make a serious attempt at improvement. Practise a little lettering carefully rather than a great deal carelessly. Keep a correct copy of the alphabet before you for reference while lettering, until you are thoroughly familiar with the letter shapes.

For the lettering exercises of this unit, lay out the standard small drawing sheet and then divide the space inside the border line into nine equal rectangles by means of two horizontal and two vertical lines. Inside these spaces, with your lettering triangle rule guide lines $\frac{5}{32}$ inch high, beginning the first one $\frac{3}{8}$ inch from the top of the enclosing space. Also rule vertical margin lines $\frac{1}{4}$ inch from the side lines of each space and keep all lettering within these margin lines.

Letter the exercises as assigned by the instructor. Work slowly but rhythmically and regularly. Do not squeeze the pencil or pen and cramp your fingers. Hold the pencil with the muscles of the fingers relaxed but ready to work. When you find yourself gripping the pencil too tightly, stop and relax for a moment, then proceed with an effort to keep relaxed.

The title of the sheet will be LETTERING EXERCISES.

1. GOOD LETTERING REQUIRES AN EXACT KNOWLEDGE OF THE LETTER SHAPES, WHICH CAN ONLY BE ACQUIRED BY CAREFUL CONSCIOUS AND THOUGHTFUL PRACTICE.

2. YOU CAN BECOME REASONABLY SKILLFUL AT LETTERING EVEN THOUGH YOUR HANDWRITING MAY BE POOR. CONSCIENTIOUS STUDY AND PRACTICE ARE THE ONLY REQUIREMENTS.

3. LETTERS AND FIGURES MAY MAKE OR MAR A DRAWING. IT IS THEREFORE ESSENTIAL THAT THE DRAFTSMAN BECOME REASONABLY SKILLFUL IN THIS TYPE OF FREE-HAND WORK.

4. UNIFORMITY OF SPACING REQUIRES THAT THE WHITE AREA BETWEEN LETTERS SHALL BE EQUAL. THIS IS MORE READILY ACCOMPLISHED WHEN THE LETTERING IS COMPACT.

FIG. 4. Lettering exercises.

5. LETTERING, WHETHER FOR PRACTICE OR FOR FINISHED WORK, SHOULD ALWAYS BE DONE SLOWLY WITH CAREFUL ATTENTION TO THE SHAPE OF EACH LETTER. HASTY PRACTISE IS WORSE THAN USELESS.

7. THE MECHANICAL DRAFTSMAN SHOULD REGARD HIS PENCIL AS A FINE TOOL JUST AS THE ARTIST DOES AND KEEP THE POINT VERY SHARP. THIS IS THE PROPER CONDITION TO PRODUCE ACCURATE RESULTS.

9. EVERY DRAWING SHOULD HAVE UPON IT A TITLE WHICH SHOULD CONTAIN THE NAME OF THE OBJECT, THE SCALE, IF IT IS A MECHANICAL DRAWING, THE DATE OF COMPLETION AND SUCH OTHER INFORMATION AS CIRCUMSTANCES MAY REQUIRE.

11. UNIFORMITY OF SHAPE MEANS THAT EACH LETTER AS IT RECURS IN A COMPOSITION WILL BE EXACTLY LIKE ALL OTHERS OF THE SAME KIND. THUS EVERY LETTER E IN ANY PARAGRAPH SHOULD BE SO LIKE OTHERS THAT THEY WOULD MATCH PERFECTLY.

13. UNIFORMITY OF SLOPE REQUIRES THE SLOPE OF ALL LETTERS TO BE THE SAME THROUGHOUT ANY PIECE OF LETTERING. LETTERS SUCH AS A, V, X, ETC. HAVE THEIR SLOPES DETERMINED BY THEIR AXES.

6. WHILE DRAWING STRAIGHT LINES THE PENCIL SHOULD BE HELD IN A PLANE PERPENDICULAR TO THE PLANE OF THE PAPER. IT SHOULD BE INCLINED SLIGHTLY IN THE DIRECTION OF MOTION.

8. THE DRAWING PENCIL SHOULD HAVE A LONG CONICAL POINT WITH ABOUT $\frac{3}{8}$ " OF LEAD EXPOSED. SINCE THE LEAD WEARS DOWN RAPIDLY THE PENCIL SHOULD BE RESHARPENED FREQUENTLY DURING EACH DRAWING PERIOD.

10. SUCCESS IN LETTERING REQUIRES NOT ONLY CORRECT LETTER SHAPES, BUT ALSO UNIFORMITY OF SHAPE, SIZE, SLOPE, SPACING AND WEIGHT. THESE FIVE REQUISITES OF GOOD LETTERING MUST BE KEPT CONSCIOUSLY IN THE FOREFRONT OF ATTENTION

12. UNIFORMITY OF SIZE MEANS THAT THE LETTERS OF THE SAME KIND ARE OF THE SAME HEIGHT AND WIDTH AND CONTOUR. UNIFORMITY OF HEIGHT CAN BE ATTAINED BY BRINGING THE LETTERS FULLY UP TO THE GUIDE LINES AT BOTH TOP AND BOTTOM.

14. THE SLOPE OF THE SO-CALLED SLANT LETTER SHOULD BE ABOUT TWO AND ONE HALF TO ONE. SLOPE GUIDE LINES MAY BE USED AT FIRST BUT THEY SHOULD BE DISPENSED WITH AS SKILL IS ACQUIRED.

Fig. 5. Lettering exercises.

15. UNIFORMITY OF WEIGHT MEANS THAT THE STROKES OF ALL LETTERS SHOULD BE OF THE SAME WIDTH. THIS WIDTH SHOULD BE THAT NORMALLY PRODUCED BY THE PEN USED. THE PAPER MUST BE CLEAR OF ALL DUST AND LINT WHICH THE PEN MIGHT PICK UP.

17. FOR DRAWING, THE HARDER GRADES OF LEAD UP TO 6H AND 7H SHOULD BE USED, WHILE FOR LETTERING, THE 2H AND 3H GIVE BETTER RESULTS. IN BOTH CASES THE SOFTER GRADES WILL NEED MORE FREQUENT REPOINTING.

16. AS A FURTHER AID TO SECURING UNIFORMITY OF WEIGHT THE PEN SHOULD NOT BE FILLED TOO FULL NOR SHOULD LETTERING BE CONTINUED UNTIL THE PEN IS DRY. WIPING THE PEN BEFORE EACH FILLING WILL AID MATERIALLY IN SECURING GOOD RESULTS.

18. IN MANY SHOPS BLUE-PRINTS ARE MADE DIRECTLY FROM PENCIL DRAWINGS ON TRACING PAPER. WHERE INK TRACINGS ARE USED ACCURATE PENCIL WORK IS ALWAYS THE BASIS OF GOOD INK WORK. SKILL WITH THE PENCIL IS THEREFORE DESIRABLE.

FIG. 6. Lettering exercises.

UNIT V

USE AND CARE OF THE RULING PEN AND THE INK COMPASSES

PURPOSE OF UNIT V

The purpose of this unit is to show how to care for and use skilfully the ruling pen and the ink compasses, and to give important information about these instruments. A further purpose is to teach certain valuable geometric constructions frequently used by the draftsman.

WHAT YOU SHOULD KNOW ABOUT RULING PENS, INK COMPASSES AND INK LINES

The ruling pen. The ruling pen is used to draw straight ink lines and curved lines other than circles or arcs of cir-

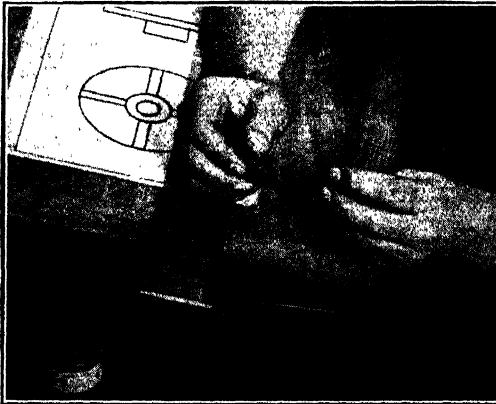

FIG. 1. Filling the ruling pen.

cles. For best results, the ink between the nibs should not stand higher than about $\frac{1}{4}$ inch above the point. The pen is filled by means of the goose-quill in the stopper of the ink bottle, as shown in Fig. 1. Care should be taken to see that there is no ink on the outside of the nibs of the pen.

Drawing ink. Mechanical drawings are always made with water-proof drawing inks. The ink may be obtained in black and also in a great variety of colors. The black ink usually dries very rapidly, but this process should not be hastened by blotting as this spreads the line, making it quite ragged, and destroys the luster.

Proper weight and character of lines. A good drawing has in it lines of many different weights and character. Figure 2 shows the kinds of lines commonly occurring in mechanical drawing. These should be carefully studied and practised. The lines of one type, as for example the visible outline, must be absolutely uniform throughout any one

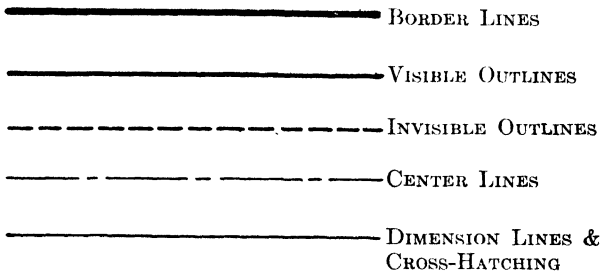

FIG. 2. Proper weight of lines.

drawing. On the other hand, there should be a distinct contrast between lines of different kinds.

Lines which are composed of dots and dashes are the most difficult to make. The secret of success is to bring the pen to a complete stop at the end of each dash or dot before lifting it from the paper. Merely to raise the pen without stopping makes the end of the line ragged and the spaces uneven. The dashes must all be of equal length and the spaces of equal length, and these lengths must be uniform throughout the drawing.

A well-inked drawing is distinguished by three things, namely: (1) *uniformity* of weight and character among lines

of one kind, (2) *contrast* between the lines of different kinds and (3) good lettering, figures and arrow-heads.

(Arrow-heads and leaders will be discussed in Unit XI.)

HOW TO USE RULING PENS AND INK COMPASSES

To fill the pen with ink. Hold the pen between the thumb and index finger of one hand with the point down, and the goose-quill stopper in the other hand with the ink-filled quill slanting down. Insert the point of the quill between the nibs of the pen and slightly twist the quill to release the ink. To steady the hands, lightly touch the tips of the little fingers together or rest your hands upon the edge of the

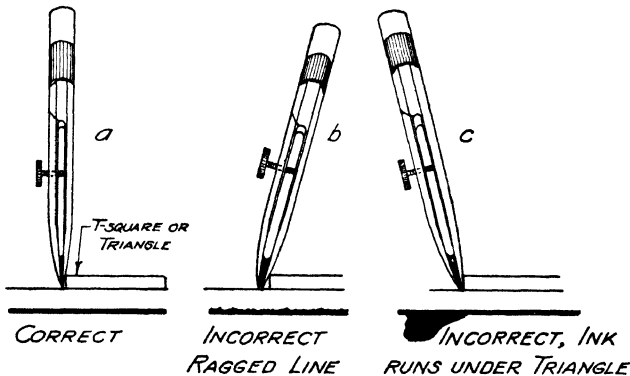

FIG. 3. Correct and incorrect positions of pen.

board as shown in Fig. 1. Practise this until you can do it rapidly without allowing any ink to get on the outside of the nibs.

To rule lines. First set the pen so as to give the width or weight of line desired by adjusting the space between nibs by means of the thumb screw, and by making trial of it upon a piece of scratch paper. When the proper adjustment has been made, hold the pen against the straight edge with just enough pressure to keep it in contact. Hold it in a plane perpendicular to the paper, with the upper end inclined slightly in the direction of motion, as shown in Fig. 3. Rule all horizontal lines from left to right, and all

vertical lines from the bottom toward the top. Rule inclined lines with the pen moving away from the body.

Learn and carefully observe the following seven rules for using the ruling pen:

1. Clean the pen frequently so that the point is not clogged with dried ink. Drawing ink coagulates very rapidly. The finer the line you attempt to draw, the more frequently the pen must be cleaned.

2. Keep the pen in a plane perpendicular to the paper. Do not tilt it to either side. Position (a) in Fig. 3 is correct. Position (b) is incorrect and will give a ragged line. Position (c) is incorrect and will cause the ink to run under the straight edge.

3. See that the paper is free from all dust, dirt and lint.

4. Do not press the pen too hard against the straight edge, or an irregular line will result.

5. Do not squeeze the nibs together either with your fingers or thumb screw as the points may become bent as in Fig. 4 and the pen be ruined.

6. If the ink does not flow readily when the point is touched to the paper, touch it on a piece of chamois skin, which will remove the clot of dried ink. Do not attempt to start the ink by putting extra pressure on the pen, but clean the pen.

7. Always clean the pen before putting it away.

To ink a drawing. Learn to follow a definite order of inking in or tracing a drawing. Unless otherwise directed by your instructor, use the following order on all your sheets:

1. Center lines.

2. Arcs and circles (visible).

3. Visible horizontal lines.

4. Visible vertical lines.

5. Visible inclined lines.

6. Invisible arcs and circles.

7. Invisible horizontal, vertical and inclined lines, in the order mentioned.

8. Horizontal, vertical and inclined dimension lines.

9. Arrows, figures and other lettering.

Begin at the top of the sheet to draw horizontal lines and work toward the bottom, then begin at the left and work toward the right, drawing all the vertical lines of any one kind, as, for example, visible outlines, as you come to them. This avoids the necessity of changing the adjustment of the pen and will make all lines of one kind uniform in weight.

To use the pen compasses. Set the pen compasses, both large and small, in the same manner as you do the pencil compass. Instead of making the setting from a scale, however, set the ink compass from the drawing itself. Adjust the needle and pen point as shown in Fig. 5.

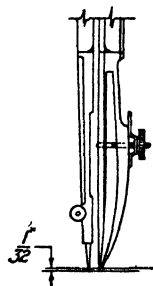
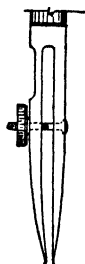

FIG. 4. Nibs bent by squeezing.

FIG. 5. Adjustment of pen compass.

When in use, bend the legs of the large compass so that the pen is perpendicular to the paper, thus bringing both nibs of the pen into contact with the paper; this is necessary to produce a full, smooth line. See Fig. 6.

If a drawing contains both circles and straight lines of the same character, i.e., visible lines, carefully adjust the pen of the compass by trial on scratch paper to give the desired weight of line. Then, when the ruling pen is used, adjust it to give the same weight of line by trial and comparison with the arc made by the compass on the scratch paper.

To join a straight line to an arc. In joining a straight line to an arc, be careful to see that the nibs are in perfect alignment with the arc before making actual contact between

pen and paper. See Fig. 7. To join a straight line and an arc at the end of the stroke, move the pen slowly, looking under the pen from above to see that a perfect connection will be made.

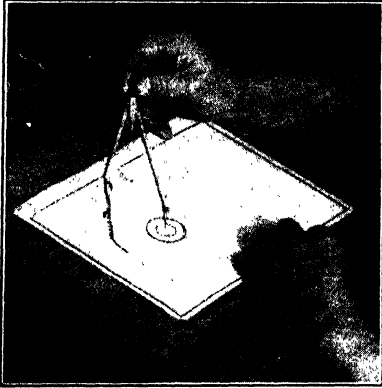

FIG. 6. Using the ink compass.

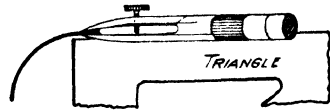

FIG. 7. Joining a straight line and an arc.

GEOMETRICAL CONSTRUCTIONS

For use in the drawing problems which follow later in the course, the following geometrical constructions should be thoroughly learned. These constructions together with those given elsewhere in the book are as useful to the draftsman as the multiplication table is to the bookkeeper. These constructions should be so well learned that they can be used automatically.

1. **To erect a perpendicular to a line through a point without the line.** With the point C as a center, describe an arc of any convenient radius which will cut the line in two places A and B as shown in Fig. 8. With these points as centers, describe two arcs 1 and 2 which intersect each other. A line through the given point and the intersection of the arcs is the required perpendicular.

2. **To reproduce any given plane figure (angle method).** Beginning at any corner A of the given figure, describe an arc cutting both sides of the angle as shown in Fig. 9. Lay

off at the desired place the line $A'B'$ equal to AB , and then with A' as a center describe an arc of the same size as the one on the original figure. Set the compass to the distance $1-2$ on the original figure, and transfer this to the similar arc on the new figure. An angle equal to the angle at A can then be constructed by drawing the line $A'D'$ the same length as AD . Having completed one angle, proceed with the next one in the same manner until the entire figure is completed.

2a. To reproduce any given plane figure (coordinate method). Enclose the figure in the smallest possible rectangle, as shown in Fig. 10. Then draw coordinates parallel

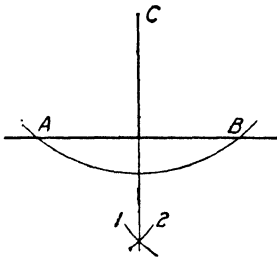

FIG. 8. Perpendicular to a line through a point.

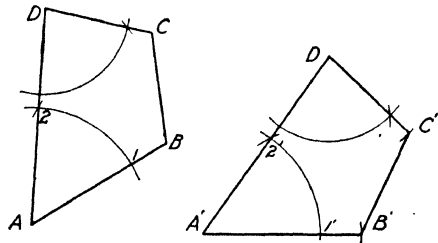

FIG. 9. Reproducing a plane figure.

to the sides of the rectangle through every corner of the plane figure. At the desired place on the paper reconstruct the rectangle and all the coordinates with the T-square, triangles and dividers. At the intersection of the coordinates, locate the required corners and draw the figure.

3. To draw a straight line tangent to a circle at a given point on the circle. Through the given point O draw a radius of the circle shown in Fig. 11. Then at any convenient point on the circle describe an arc (more than 180 degrees) which passes through the original point and cuts the radius at A . Draw a straight line from the point A through the center of the arc, extending it until it cuts the arc again at B . A line through B and the original point O will be tangent to the circle. This construction depends upon the fact that two cords meeting at a point on a circle and join-

ing the end points of a diameter are at right angles to each other which is, of course, the relationship between the radius and tangent to any point on a circle.

4. **To draw a straight line tangent to a circle through a point outside the circle.** Draw a line from the point *A* to the center of the circle as in Fig. 12. Bisect the line. With the mid-point thus found as a center, draw an arc passing

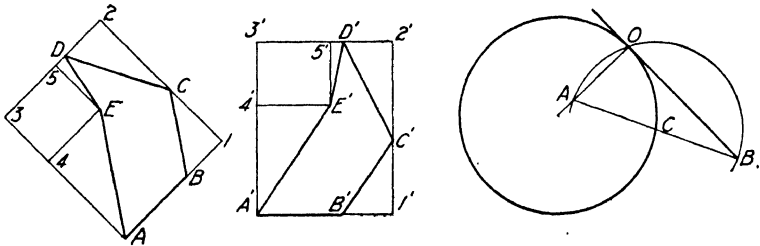

FIG. 10. Reproducing a plane figure. FIG. 11. Line tangent to circle.

through the center of the circle. Where this arc cuts the circle is the point of tangency. Draw the tangent. Upon what proposition in geometry does this construction depend?

5. **To draw a straight line tangent to two circles.** Draw a line joining the two centers and extend it beyond the center of the smaller circle. At the center of each circle erect

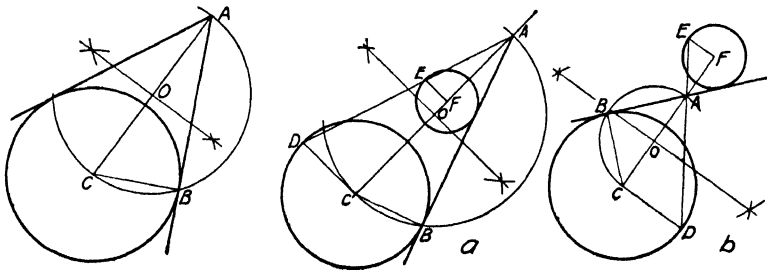

FIG. 12. Line tangent to a circle.

FIG. 13. Line tangent to two circles.

a radius perpendicular to the line. Draw a line through the ends of these radii and extend it until it cuts the line through the centers. Through this point draw a line tangent to the large circle by the method above. This line will be tangent to the smaller circle also. For the other tangent as shown in

Fig. 13b, erect the perpendicular radii on opposite sides of the line joining the center, and then proceed as before.

Note: For ordinary drafting work, the constructions of paragraphs 3, 4 and 5 need not be used. Tangents may be drawn simply by bringing the triangle into a tangent position by eye.

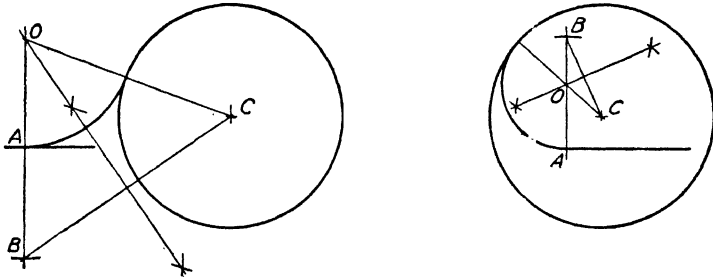

FIG. 14. Arc tangent to a line and a circle.

6. **To draw a circle tangent to another circle and tangent to a right line at a given point.** At the given point *A*, see Fig. 14, lay off the distance *AB* equal to the radius of the circle on the opposite side of the line from the center of the circle. Join the center of the circle with the point *B* and then bisect this line. The point where the bisector intersects the line *AB* produced is the center of the tangent circle. Figure 14b illustrates the construction when the point is

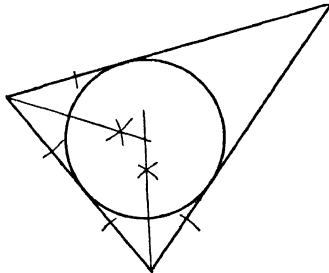

FIG. 15. Inscribing a circle in a triangle.

inside the circle. Note that in each case the construction depends upon the fact that the center is on the bisector of the base of an isosceles triangle.

7. **To inscribe a circle within a triangle.** The center of

the circle must lie on the bisector of each angle of the triangle. Hence the common point of the bisectors is the center. See Fig. 15.

QUESTIONS

1. How high should the ink stand between the nibs of the ruling pen?
2. Explain how the pen should be held relative to the drawing paper.
3. If the upper part of the pen is tilted over the T-square, what kind of line results?
4. If the upper part of the pen is tilted away from the T-square, what kind of line results?
5. If the pen is pressed too hard against the T-square, what kind of line results?
6. About how wide should the lines be which represent the visible outline of an object? Illustrate.
7. How wide should invisible lines be, and what should be their character? Illustrate.
8. How wide should dimension lines and center lines be? Illustrate the character of each.
9. What one quality is essential for good appearance in all dash lines?
10. What precaution must be taken when joining arcs and straight lines when inking?
11. Which should be drawn first, straight lines or arcs? Why?
12. How may uniform width or weight of straight lines and arcs be assured?
13. Show by a sketch and explain how to draw a line tangent to a circle at a given point on the circle.
14. Show by a sketch and explain how to reconstruct any plane figure by the angle method.
15. Show by a sketch and explain how to reconstruct any plane figure by the coordinate method.
16. Show by a sketch and explain how to draw a line tangent to a circle through a point outside the circle.
17. Show by a sketch and explain how to draw a line tangent to two circles.
18. Show by a sketch and explain how to draw a circle tangent to another circle and to a line at a given point on the line.
19. Show by a sketch and explain how to divide a line into any number of equal parts.
20. Show by a sketch and explain how to inscribe a circle within a triangle.

PROBLEMS

The problems of this unit are to be done first with a sharp pencil. Exactness of measurement and accuracy of construction are the chief objectives. Leave all pencil construction lines until the pencil work has been approved by the instructor, then ink in the work, using light lines of about the weight designated for dimension lines. This applies to all problems in this unit.

Draw first the standard border line and title space. Divide the space inside the border into four equal rectangles by means of a horizontal and a vertical line; then solve the problems assigned.

1. A little below the center of the rectangular space on your drawing sheet, draw a line about 3 inches long making an angle of 15 degrees with the horizontal. Select a point about $1\frac{1}{2}$ inches above the line near the middle. Through this point erect a perpendicular to the line.

2. A little to one side of the center of the rectangular space draw a line $2\frac{1}{2}$ inches long making an angle of 75 degrees with the horizontal. Select a point about 2 inches from it near the middle. Through this point erect a perpendicular to the line.

3. Reproduce a plane figure drawn by the instructor. Use the angle method. Leave all of your construction lines in pencil.

4. Reproduce a figure as drawn by your instructor. Use the co-ordinate method.

5. Draw a circle $2\frac{1}{4}$ inches in diameter. Select a point on the circle, and then construct a tangent to the circle at the point.

6. Draw a circle $1\frac{3}{4}$ inches in diameter. Select a point on the circle and then construct a tangent to the circle at the point.

7. Draw a circle $1\frac{1}{2}$ inches in diameter and select a point about 2 inches from the circumference. Construct a tangent to the circle through this point.

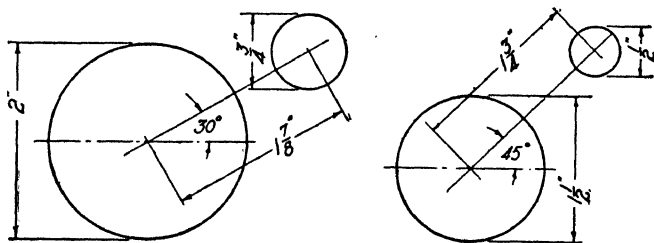

FIG. 16.

8. Reproduce two circles as assigned from Fig. 16, full size. Construct two tangents to the circles.

9. Reproduce full size one of the triangles as assigned from Fig. 17. Inscribe a circle within it which shall just be tangent to all sides. Leave all your construction lines in pencil.

10. Draw a line and divide it into equal parts as specified below. Show your construction. See Fig. 12, p. 10.

- (a) a line $2\frac{1}{2}$ inches long into 6 parts.
- (b) " " $3\frac{1}{4}$ " " " 5 " .
- (c) " " 4 " " " 7 " .
- (d) " " 2 " " " 3 " .

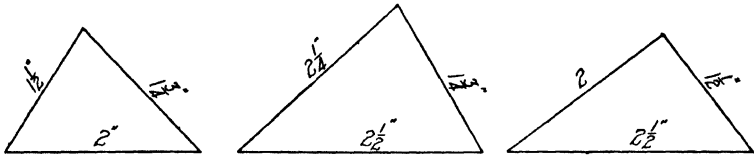

FIG. 17.

11. Reproduce full size the point, line and circle as assigned from Fig. 18. Construct a circle tangent to the given line at the given point A and tangent to the circle.

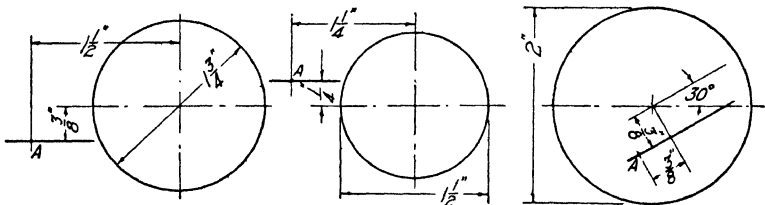

FIG. 18.

12. Reproduce full size one or more of the problems assigned from Fig. 19. See Unit XVIII for construction of pentagon and hexagon.

Note: The construction for the location of the centers of all the circles in these problems depends upon the same principle as that used in inscribing a circle within a triangle.

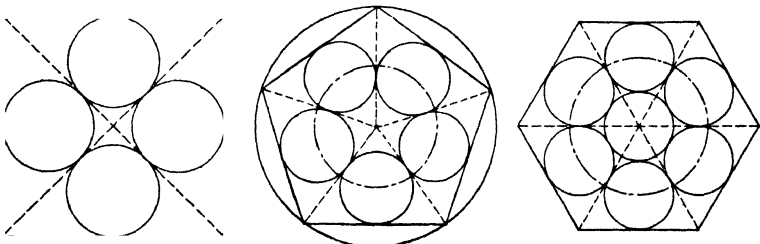

FIG. 19.

13. Copy full size the working drawing shown in Fig. 1, Unit XIII.

14. Copy full size the working drawing shown in Fig. 2, Unit XIII.

UNIT VI

LETTERING OF TITLES, LEGENDS AND NOTES

PURPOSE OF UNIT VI

The purpose of this unit is to show how to plan and letter the titles, legends and notes used on drawings.

WHAT YOU SHOULD KNOW ABOUT TITLES, LEGENDS AND NOTES

Every drawing, whether only a preliminary freehand pencil sketch of something to be made or worked on, or a highly finished map or machine drawing, should have a title. This title on formal drawings should contain a statement of what the drawing is, by what company it is made, for whom the object or structure is to be made, the name or initials of the draftsman and checker, the scale of the drawing and the date of its completion. On less formal drawings, such as sketches, the name of the object, the draftsman and the date will frequently be sufficient. In all cases, however, the title must bear enough information to identify the drawing completely.

In general, the most important item of the title is the name of the drawing or the name of the object represented. The name of the company making the drawing or design or manufacturing the object is also of importance, as is the name of the person or firm for whom it is to be made. The draftsman's name, the scale and date are usually in the smallest size lettering. The names of the town and state occupy an intermediate position.

Position and form of title. The position of the title upon the sheet, and its form, are usually decided for the draftsman by those for whom he works. Two forms are in general use. One is the box title, which is generally placed in the lower right-hand corner of the sheet where it is convenient

for reference after the drawing is placed in the file. The second is the title strip, which is arranged as a narrow band across the bottom of the sheet just inside the border line. Both forms are quite satisfactory.

Sub-titles or legends. Sub-titles, or legends, are frequently placed under different parts of a drawing in order to identify the parts and to show their relation to other parts. Such phrases as First Floor Plan, West Elevation, Section AA and the like are common examples. Such legends are used especially where more than one object is placed upon a sheet, or where the various views of the same object occur on different sheets, as, for example, in house plans. Such sub-titles or legends are usually not placed in boxes.

HOW TO PLAN AND LETTER TITLES AND NOTES

To balance titles. All titles, regardless of whether they are enclosed in a box or not, should be balanced. A balanced

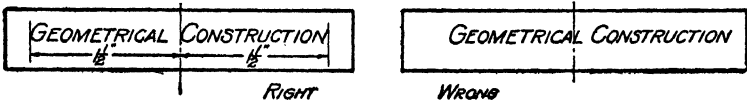

FIG. 1. Balancing title in a box.

title is one which is arranged symmetrically about its center line. If the title is to be enclosed in a box, make its center line coincide with the center line of the box, as shown in Fig. 1. If the title has several lines, make each line extend

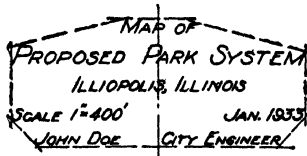

FIG. 2. Balanced title.

just as far on one side of the center line as it does on the other; this produces a symmetrical outline or contour for the title as a whole, as shown in Fig. 2.

To lay out the title. Write out the title in longhand, and balance it as accurately as you can without measuring it. Then count the letters in each line. Count the spaces between words as a letter, and determine the exact center of the line. Place the center of each line of lettering on the center line of the box or title strip and letter the title by working out from the center line in both directions as shown in Fig. 3. Putting down the letters in reverse order on the left-hand side of the center line may seem a little awkward at first, but with practise it will be found to be as easy as in the other direction.

If in this first attempt the lines are not perfectly balanced, erase such parts as are out of balance and reletter in pencil until symmetry is secured. The draftsman with pride in personal achievement will not hesitate to erase several times and try again until the result is acceptable.

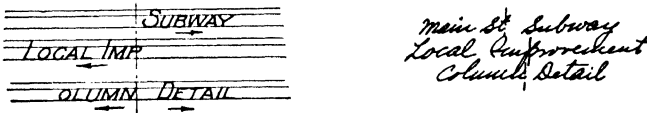

FIG. 3. Balancing a title.

Size and style of lettering. Be careful to maintain the same style of lettering throughout the title. To indicate the relative importance of the various lines of the title, use different sizes of letters for lines of different degrees of importance, the larger sizes for the more important parts. For ordinary work on shop drawings these sizes will range from $\frac{1}{4}$ inch for the largest to $\frac{3}{32}$ inch for the smallest, with $\frac{3}{16}$ and $\frac{1}{8}$ inch as the more common upper and lower limits of height.

To letter notes. Always letter notes horizontally on drawings, both for the sake of good appearance and as an aid in reading them. Make the letters in notes smaller in size than the letters in the sub-titles under various parts of the drawing, and than the major parts of the main title. One-

eighth inch and $\frac{5}{32}$ inch are the more common heights of letters for notes.

If notes are long, as is sometimes the case, arrange them in paragraphs instead of balancing them. When they consist of only two or three short lines, balance the lines; but when there are five or six lines of continuous reading material in the form of sentences, use the paragraph form. This takes less time to arrange, is neat in appearance and follows the usual practise in printed reading matter.

QUESTIONS

1. If a one-line title is placed within an enclosing box, illustrate by a sketch how it should be placed.
2. If there are three or more lines in a title, illustrate by a sketch, using a heavy horizontal bar to represent each line, just how the lines should be placed with reference to each other.
3. If a title is not placed within a title box, how should the various lines of the title be arranged?
4. What is the first step in balancing a title?
5. If the first attempt to balance a title does not result in a perfect balance, what is to be done about it?
6. How or upon what basis is the size of lettering to be used in each line of the title determined?
7. In what position should notes be placed upon a drawing? What reason can you give for your answer?
8. If a note is long and consists of one or more complete sentences, how should it be arranged on the sheet?
9. Which should have the larger letters on a drawing—notes, or sub-titles?
10. Under what conditions are legends or sub-titles used on a drawing?
11. What should be the height of letters in notes on ordinary shop drawings?
12. What are the maximum and minimum heights of letters to be used in the titles of shop drawings?

PROBLEMS

Lay out the standard border line and title space, then subdivide the sheet into four equal rectangles by means of a horizontal and a vertical line. Within these spaces, letter four of the assigned titles from the list below. The title should be balanced about the vertical center line of the space in which it is placed and

approximately about the horizontal center line as well. In regard to balancing the title about the horizontal center line, it has been found that a better appearance is secured when the distance between the bottom of the title and the lower border line of the space is somewhat larger than the distance above the title. This difference, however, must not be large.

The objective of this problem is a balanced title well lettered in each space. Study the title assigned, decide which lines are most important and then rule in guide lines so that each line of lettering will be of such height as to have the proper emphasis in the title. On a piece of scratch paper write out the title in the form in which you want it to appear, and determine the center of each line by counting the letters and the spaces between words. Then letter the title in pencil on the drawing sheet. If your first attempt does not give the desired results, erase the irregular parts and try again, and, if necessary, again until the title is balanced.

Secure the approval of the instructor, then ink in the work. Do not present work for approval that has any line perceptibly out of balance either to the unaided eye or by measurement. No correction of the balance or other arrangement of the title will be permitted in the ink work. You cannot improve upon the pencil work when inking.

Balance the following titles within the spaces in which they are placed.

1. East Elevation, Scale $\frac{1}{8}'' = 1'-0''$.
2. Rocker Arm, Cast Iron, 6 Required.
3. Section A A Monitor Sash, See Sheet No. 17.
4. Postcap No. 15 B, Pressed Steel, Paint one coat.
5. Crankshaft, Motor No. 374, S.A.E. No. 526.
6. Isometric of Bracket, Mech. Drawing 2A, Lafayette High School, Lafayette, Indiana.
7. Detail of Col. Footing, Nos. 1,3,5,7 & 9.
8. Property Map, Malley M'F'G. Co. Waukegan, Ill., Scale $1'' = 100'$. Aug. 1932, John Doe, Surveyor.
9. Required 6 lintels as shown, each composed of 1-8" 18# I, 1-12 x $\frac{3}{8}''$ Pl, 1-2 x 2 x $\frac{1}{4}''$ L.
10. Yard Map, Illinois Central Railroad, Champaign, Ill. John Doe, Division Eng'r. Scale $1'' = 400'$. April 10, 1933.
11. Map of Proposed Harbor, Illinois Yacht Club, Chicago, Illinois. Scale $1'' = 200'$. June, 1933. Richard Roe, Eng'r.
12. Perspective and Floor Plan, Memorial Museum, Mishawaka, Ind.

The wording of your title need not be in the order given. In fact, in some cases it cannot be so arranged. The title of the sheet will be **TYPICAL TITLES**.

UNIT VII

ORTHOGRAPHIC PROJECTION. TWO VIEWS, STRAIGHT-LINE OBJECTS

PURPOSE OF UNIT VII

The purpose of this unit is to explain the meaning, character and use of orthographic projection in mechanical drawing.

WHAT YOU SHOULD KNOW ABOUT ORTHOGRAPHIC PROJECTION

Purpose of mechanical drawing. All drawings, whether they are the artist's freehand sketch or painting or the engineer's working drawing, are intended to convey ideas to those who view them. In the case of the artist's work only a general impression is intended to be conveyed, or perhaps a feeling or mood, but the engineer's drawing describes an *object*, be it a machine, a bridge or a building, in exact, definite and unmistakable terms. The purpose of mechanical drawing, then, is to describe the shape of objects with accuracy and exactness.

Orthographic projection. Pictures, perspectives, or other pictorial views of an object, though presenting an appearance similar to what the eye sees, do not represent the true relationships between the lines and surfaces which go to make up the object. In order to present these relationships exactly so that the mechanic or workman can make the object, a form of drawing called *orthographic projection* has been devised.

The phrase "to project," as used in geometry and drawing, means to throw forward in a given direction, or to extend forward a point, line or plane to some surface upon which it is going to be represented. Hence, in drawing, the corners, edges and surfaces of an object are said to be *pro-*

jected upon the plane on which they are represented. Thus in Fig. 1 the corner *A* of the step block is *projected* along the dotted line to the plane *HVST*, and the point *a'* is said to be the *projection* of *A* upon the plane. The dotted line along which the point is supposed to be moved is called a *projecting line*. The plane upon which the drawing or projection is made is called a *plane of projection*.

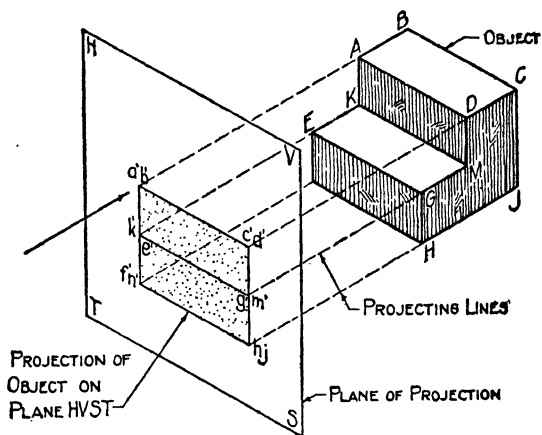

FIG. 1. Orthographic projection on vertical plane.

Note: The definition of the italicized terms should be carefully and accurately learned so that they may be used and understood in discussions.

Now a point or line on an object might be projected forward to the plane in any desired direction. Projections in any direction chosen at random, however, would not all be equally valuable in revealing the shape of the object; hence it is necessary that we select a direction for our projecting lines which will show the object to best advantage for purposes of construction. This is accomplished best when the projecting lines make angles of 90 degrees with the plane of projection. Projections of this type are called *orthographic projections*. An orthographic projection, then, may be defined as any view of an object made by projecting lines which are perpendicular to the plane of projection.

An examination of Fig. 1 will show at once that a single orthographic projection, or view, as it is sometimes called, is insufficient to describe completely the shape of even the simplest object, since it gives no idea at all of the depth AB or HJ of the object in a direction perpendicular to the plane of projection.

Principal planes of projection. If, however, another plane is set perpendicular to the first one as shown in Fig. 2 and an orthographic projection of the object is made also on

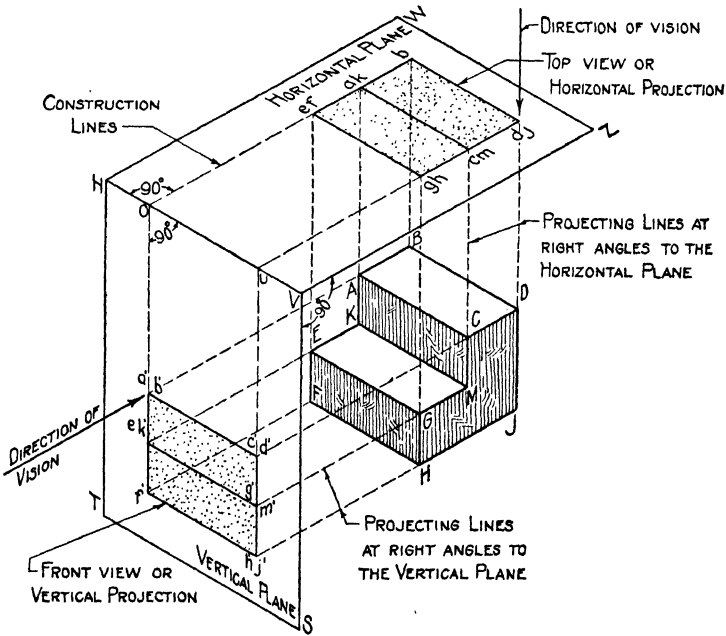

FIG. 2. Orthographic projection on horizontal and vertical planes.

this plane, the depth of the object AB and HJ which was not shown in the first view is now represented upon the second plane. Hence it is clear that two orthographic projections are always necessary to describe the shape of even the simplest object. These projections are always made upon two planes which are assumed to be horizontal and vertical, and they are called the horizontal and vertical planes, respectively, or the *principal planes of projection*, when re-

ferred to collectively. The projection upon the horizontal plane is called the *horizontal projection*, and that upon the vertical plane the *vertical projection*.

Point of sight. Although projections of an object are understood to be found as just explained, perhaps a better way to think of them is to regard them as views of the object obtained from different positions. The projecting lines which are all perpendicular to the planes may then be regarded as *lines of sight*. Since these lines of sight are perpendicular to one plane, they must be parallel to each other; hence, it is necessary to imagine that the point of sight to which they converge is at infinity, because by definition in geometry parallel lines are said to meet at infinity. The point of sight, then, may be defined as the imaginary position at infinity taken by the observer to get a particular view. It follows that there are as many points of sight as there are views or projections. In making the vertical projection, or front view, as it is more frequently called, the observer is assumed to be at an infinite distance in front of the object and to be looking through the plane of projection, which must be imagined to be transparent. In this position, only the front view is visible, and the top of the object cannot be seen; hence to get a top view the observer must change his position and look down upon the object from above, the point of sight being again at infinity in this direction.

The arrows in Fig. 2 indicate the direction in which the observer looks to get the two views of the object. It will be noted that in looking at the front view the horizontal plane of projection appears edgewise, and the distance of the object below that plane can be clearly seen, as can also the vertical distance between the various lines of the object itself. In the same way, in looking down upon the top view the vertical plane is seen edgewise, and the distance of the object behind it can be seen. The distance of one point or line on the object behind another point or line also appears.

The drawings of this unit should be carefully studied until these relationships are clearly understood.

The object. We have now definitely established the relationship between the *point of sight*, *projecting lines* and *plane of projection*. The position of the object relative to the plane of projection, however, is equally important with the other things, for unless it is properly placed an orthographic projection might have little value for construction purposes. The purpose of a mechanical drawing is to show clearly the true shape of all parts of the object, and the true relationship between them. A little study will show the following things to be true:

1. A line on an object will show in its true length only when the line is parallel to the plane of projection.
2. A plane face of an object will show in its true shape only when it is parallel to the plane of projection.

In order to accomplish our purpose, then, it is necessary that we place the object with its principal faces parallel respectively to the planes of projection. These faces will show in their true shape in the projections, and hence can be used as an accurate guide in making the object.

The views of the object discussed thus far have been shown upon two planes which are at right angles to each other, but the draftsman must represent both of them upon one flat piece of paper. This is accomplished by drawing a line upon the drawing paper to represent the planes of projection and their line of intersection and noting the relationship of the views of the object to this line and to each other. It will be seen in Fig. 2 that the construction lines *oe*, *oa'*, *ug*, etc., are perpendicular to the line of intersection *HV* of the planes.

Hence, if we were to draw the line *HV* on paper, and at the proper distance behind it construct the top view of the object, as shown in Fig. 3, this would represent the appearance of the object and the planes of projection as seen from above. If we did the same thing for the front view, Fig. 4

would be the result, as may be seen by comparison with Fig. 2.

In Fig. 2, however, it is seen that the two views bear a

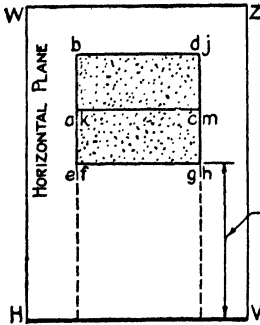

FIG. 3. Top view.

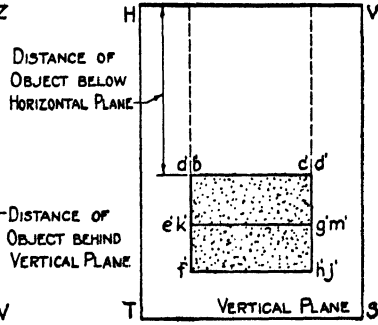

FIG. 4. Front view.

definite relation to each other, and this relationship must be retained in the drawing; hence, instead of making the two views at different places, the line *HV* is drawn only once, and the two views, top and front, are placed in their proper relation to it as shown in Fig. 5.

The line *HV* in Fig. 3 represents the vertical plane seen edgewise; in Fig. 4, the line *HV* represents the horizontal plane seen edgewise. In the combined view of Fig. 5 the line *HV* still has both these meanings. In other words, when the draftsman is looking at the front view of the object the line *HV* represents the edgewise view of the horizontal plane, and when he looks at the top view of the object this same line now represents the *V* plane edgewise. The boundaries of the planes of projection, of course, need never be shown since their size or extent has no bearing on the problem. From Fig. 5, then, we note that the two projections of the object are in vertical alignment and that

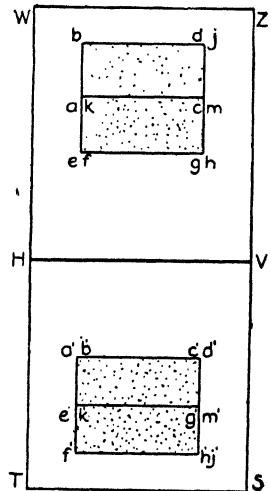

FIG. 5. Top and front views combined.

the two projections of each point in it lie in the same perpendicular to the line HV , which is sometimes referred to as the *ground line*. This relationship in projection must never be violated in mechanical drawing. It is frequently stated in this manner: "The two projections of a point lie in the same perpendicular to the ground line."

In Fig. 6 is shown a pictorial view of an object and the two planes of projection; Fig. 7 shows the two orthographic

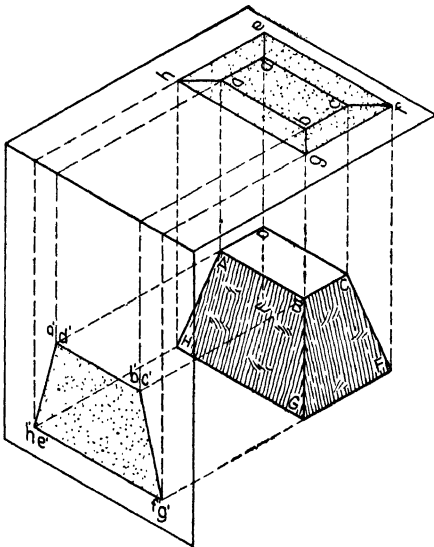

FIG. 6. Pictorial view of projections.

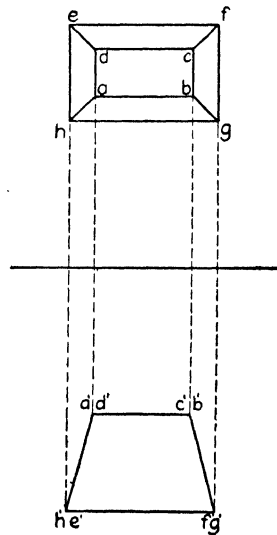

FIG. 7. Top and front views of pyramid in Fig. 6.

views as the draftsman would make them. The draftsman must be able to interpret a drawing like Fig. 7 in detail, and we shall therefore study the lines and planes of this object and note their relationship to the two principal planes.

The lines AB , DC , EF and HG are parallel to both the horizontal and vertical planes. Note the position of the projections of these lines relative to the ground line in Fig. 7. The top view clearly shows these lines to be parallel to the vertical plane, which is seen edgewise in the ground line. The front view likewise shows them to be parallel to the

horizontal plane, which is shown edgewise in the ground line.

The lines EH , AD , BC and FG are parallel to the horizontal plane and perpendicular to the vertical plane. In this case, the top view does not in itself clearly establish the fact that the line EH has the position described; but the front view, which shows $e'h'$ as a point, clearly establishes the fact that the line itself must be perpendicular to the vertical plane. If it is perpendicular to the vertical plane, it must be parallel to the horizontal plane.

The lines ED , BG , CF and HA are inclined to both planes, as may be seen from an examination of the two views. To see this in Fig. 7 it must be remembered that the ground line represents in each view one of the planes of projection seen edgewise; in this way the relationship between the lines and the planes is revealed.

The plane faces $ABCD$ and $EFGH$, representing the top and bottom of the object, are parallel to the H plane, as may be seen in the front view which shows these planes edgewise. They are also, by virtue of being parallel to H , at once seen to be perpendicular to the V plane.

The sides $ADHE$ and $BCGF$ are perpendicular to the V plane and inclined to the H plane, since they show edgewise in the front view and inclined to the H plane.

The front and rear faces $ABGH$ and $DCFE$ are inclined to both the H and V planes since they do not show edgewise in either view.

QUESTIONS

1. What is meant by the "Point of Sight"?
2. How many viewpoints or "points of sight" are used in making a two-view drawing?
3. At what distance from the plane of projection is the point of sight assumed to be in all orthographic projection?
4. What is meant by a plane of projection?
5. How many planes of projection are used in a two-view drawing?
6. What is the relationship of the two planes of projection to each other?

7. What should be the position of the object relative to the plane of projection?
8. What is meant by a projecting line? Illustrate by a sketch.
9. What is the relation of the projecting line to the plane of projection?
10. Which of the following terms are equivalent or synonymous: plan, front view, horizontal projection, top view and vertical projection?
11. Why is it necessary to make more than one orthographic view of even the simplest object to describe its shape completely?
12. What is the usual commercial purpose of making orthographic projections or drawings?
13. What information concerning the object does the top view give?
14. What information concerning the object does the front view give?

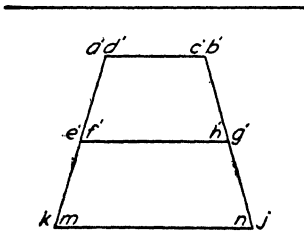
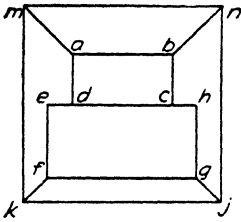

FIG. 8. Top and front views of abutment.

In this text, when points on an object are referred to by letter, the capital letter is used, whereas the projections of the point on the various planes are designated by the corresponding small letters. Thus, in Fig. 8 small *a* and small *a'* represent the horizontal and vertical projections of the same point *A* on the object. Hence the lines and planes of questions 15 to 23 should be named by capital letters.

15. Name the lines on the object shown in Fig. 8 which are parallel to *H* and *V*, as, for example, *KJ*.
16. Name the lines on the object shown in Fig. 8 which are parallel to *H* and perpendicular to *V*, as, for example, *AD*.
17. Name the lines on the object shown in Fig. 8 which are parallel to *V* and inclined to *H*.
18. Name the lines on the object shown in Fig. 8 which are inclined to *H* and *V*.
19. Name the planes which are parallel to *H* in Fig. 8, as, *ABCD*.

20. Name the planes which are parallel to V .
21. Name the planes which are perpendicular to H .
22. Name the planes which are perpendicular to V .
23. Name the planes which are inclined to H and V .

PROBLEMS*

Lay out the standard border line and title space. Divide the space inside the border line into two equal parts by a vertical line, then make the front and top views of the objects assigned from the following group. Scale full size.

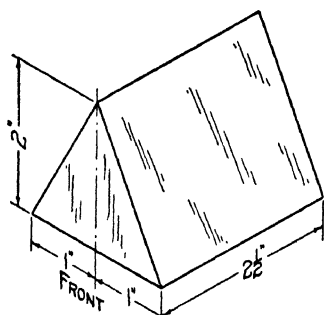

FIG. 9. Wedge.

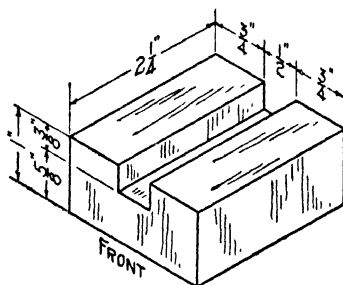

FIG. 10. Grooved block.

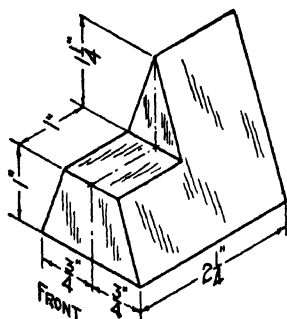

FIG. 11. Stepped wedge.

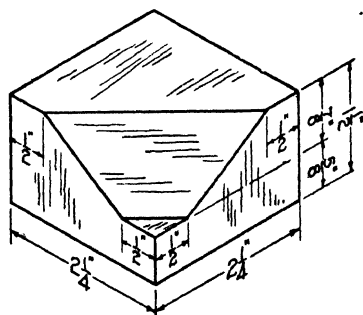

FIG. 12. Block.

* A further wide selection of problems of all kinds may be found in "Engineering Drawing" by Jordan and Hoelscher. These are designed to fit the same size of drawing paper as in this text and will be found very convenient for supplementary problems since they may be assigned without additional instruction of any kind as to sheet layout.

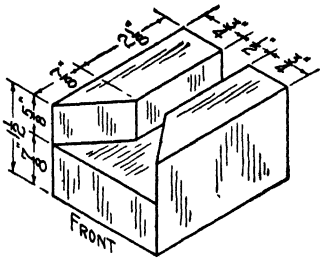

FIG. 13. Block.

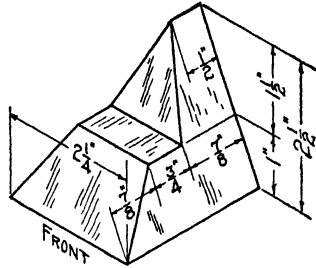

FIG. 14. Stepped and beveled block.

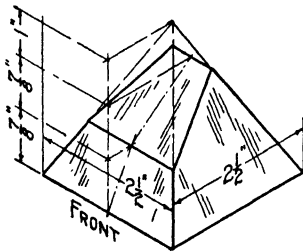

FIG. 15. Truncated pyramid.

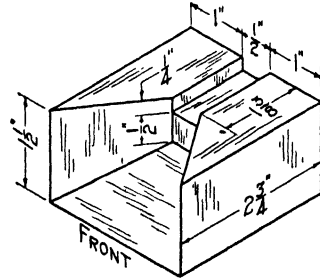

FIG. 16. Block.

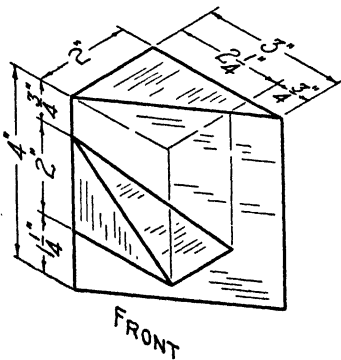

FIG. 17. Block.

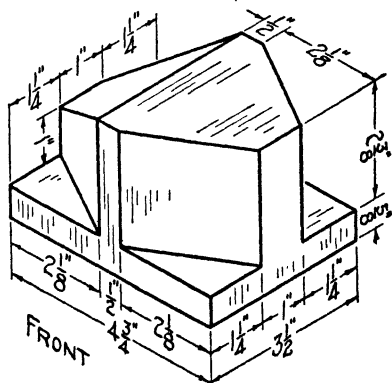

FIG. 18. Block.

UNIT VIII

ORTHOGRAPHIC PROJECTION. TWO VIEWS, CURVED AND HIDDEN LINES

PURPOSE OF UNIT VIII

The purpose of this unit is to show how to represent hidden lines and curved surfaces in the different projection planes used in making working drawings.

WHAT YOU SHOULD KNOW ABOUT HIDDEN LINES AND CURVED SURFACES IN DRAWINGS

Hidden lines. In all drawings of a practical kind, some of the bounding lines of the object will be invisible from various points of view. Some of the edges cannot be seen when viewing the object from the front, and others are invisible when the object is viewed from above. In order to give a clear idea of the shape of the object these lines must not only be shown but they must also be clearly distinguished from the visible lines. This is accomplished by using a dash line to represent the invisible lines, as shown in Fig. 1, which represents a rectangular block with a square hole in the rear face and a round hole in the front face.

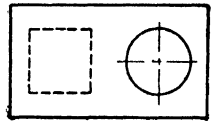
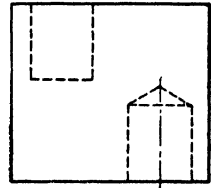

FIG. 1. Invisible lines.

Natural position vs. few hidden lines. In any drawing it is desirable to have as few hidden lines as possible because they are both harder to draw and harder to interpret. Hence, the object should be placed with reference to the planes of projection in such a way that the least number of hidden lines will be necessary. However, where the object has a certain natural position in which it is always or most usually found, that is the po-

sition in which it should be drawn, regardless of the number of hidden lines. Thus a table or stool would be drawn in its natural position rather than upside down, even though the latter position did eliminate some of the hidden lines. See Fig. 2.

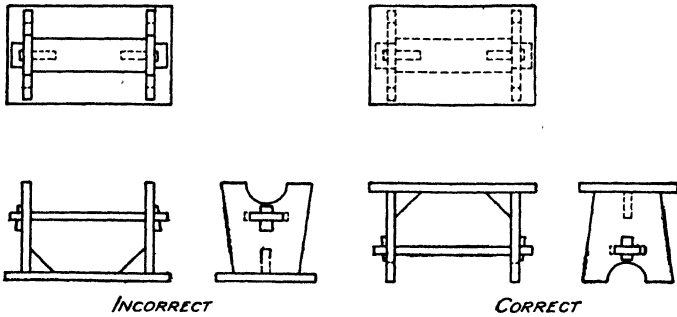

FIG. 2. Correct and incorrect positions of object.

Curved surfaces. An element of a cylinder or cone is simply an imaginary straight line which may be drawn in the surface. As many such elements may be drawn as desired, but for the ordinary problems it is customary to use only twelve of these imaginary elements equally spaced around the surface. The mere representation of the cylinder requires the use of only the two outstanding elements in the front view.

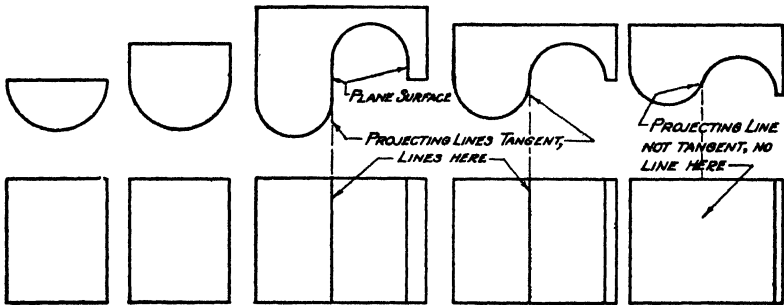

FIG. 3. Representing curved surfaces.

The front view of a half cylinder would look the same as that of the whole cylinder, as would also a rectangular prism with a half cylinder in front of it. See Fig. 3. When

combinations of curved surfaces are to be shown, as is very often the case, difficulty is sometimes experienced in clearly representing the surfaces. The following rule, which is illustrated in a number of instances in Fig. 3, will help to solve the difficulty. Whenever the projecting line can be drawn tangent to the surface, a straight line should be shown in the view to which the projecting line belongs.

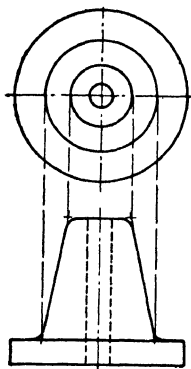

FIG. 4. Representing rounded corners. Case 1.

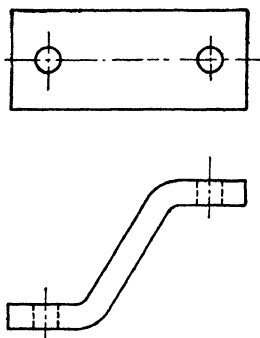

FIG. 5. Representing rounded corners. Case 2.

Objects made of cast iron frequently have the corners filleted and the edges rounded. When the surfaces are nearly at right angles and the radius of the curve is small ($\frac{1}{8}$ inch), the corner is represented as though it were sharp, as in Fig. 4. The circles in this view are projected from the point where the actual intersection of surfaces would be. When the rounded corners are of greater radius and the slope between faces departs more from a right angle, no lines are shown. See Fig. 5.

HOW TO REPRESENT HIDDEN LINES AND CURVED SURFACES

To draw hidden lines. Show hidden lines by making dashes about $\frac{1}{8}$ inch long separated by spaces a little less than $\frac{1}{16}$ inch long. Make these dashes and spaces uniform in length throughout the drawing. Be careful to form the dash so that it will be square ended on both ends, whether made

with pen or pencil. To do this, bring the pencil or pen to a full stop at the end of each dash before lifting it from the paper to begin the next one. Always draw hidden lines lighter in weight than the visible outline.

Where a hidden line meets a visible outline as at *a* in Fig. 6, make the dash touch the solid line as shown. Where an invisible line meets a visible outline and then continues across it as a visible line, as at *b* in Fig. 6, make the visible lines touch each other but do not let the dash line touch the visible line. Where invisible lines which have no relationship to each other intersect, let them cross at random, that is, hit or miss as regards dashes and spaces, as shown at *c* in Fig. 6. Where invisible lines meet representing a

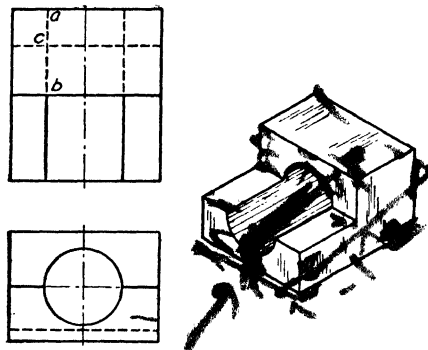

FIG. 6. Drawing invisible lines.

corner or edge as in Fig. 1, make the dashes meet in order to define the corner clearly. Not only does careful observation of these rules make for better-looking drawing, but furthermore it is necessary in order to show exactly where the invisible portion of a body ends.

To represent curved surfaces. Represent curved surfaces by means of curved and straight lines. To make a drawing of a right circular cylinder, for example, represent one view by a circle and the other by four straight lines, as shown in Fig. 7a. The upper and lower straight lines, $a'b'$ and $c'd'$, represent the plane surface of the top and bottom respectively, while the lines $a'c'$ and $b'd'$ represent the outstanding

elements of the cylinder to which the lines of sight or projecting lines come tangent, as represented in Fig. 7b.

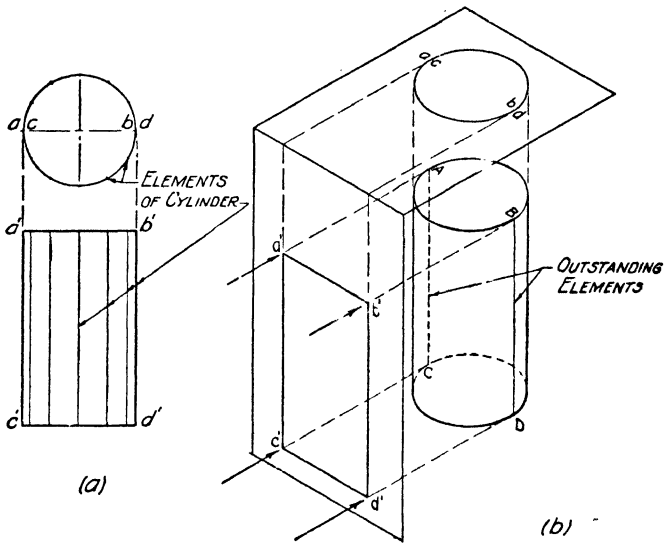

FIG. 7. Representing a cylinder.

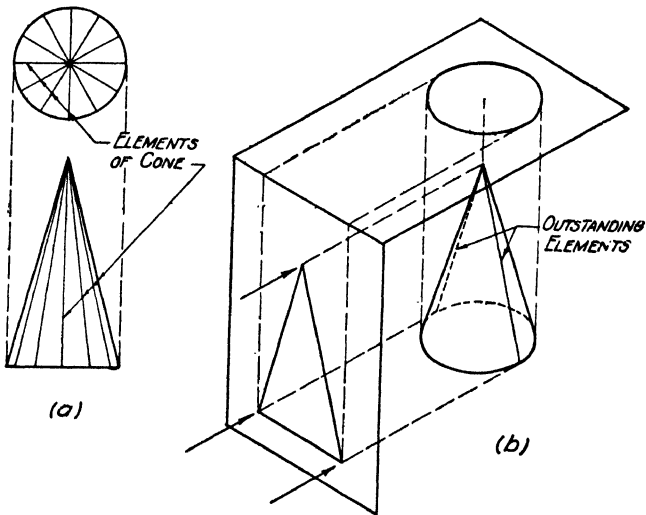

FIG. 8. Representing a cone.

Represent a right circular cone as shown in Fig. 8a. The elements again may be chosen as needed, only the two out-

standing ones being necessary in the front view to represent the cone. These outstanding elements are not drawn in the top view.

QUESTIONS

1. How are curved surfaces represented in a drawing?
2. When two parts of a curved surface are tangent to each other, under what condition does this line of tangency show in a drawing? Illustrate by a sketch.
3. How are lines upon the inside of an object which ordinarily cannot be seen, represented upon a drawing?
4. What should be the approximate length of the dashes and spaces in a so-called hidden line?
5. What should be the weight of a hidden line relative to the visible outline of an object?
6. Show by a sketch how the junction of a hidden line and a visible line should be made when they meet at right angles to each other.
7. Show by a sketch how the junction of a visible and an invisible line should be made when they are collinear and terminate upon the same visible line which is at right angles to both.
8. Describe accurately the motion of the ruling pen when making an invisible line in order that the dashes may be square ended.
9. State the two rules governing the position in which an object should be drawn as regards hidden lines. State which takes precedence.
10. What is meant by an element of a cone or cylinder?
11. Show by a sketch how to represent properly an invisible square hole in an object.

PROBLEMS

Lay out the standard border line and title space and then divide the sheet into two equal parts by means of a vertical line through the center. In each space make the top and front view of one of the objects assigned from the following group. Use the scale specified with each object, and balance the views within the space upon the vertical center line. Scale *A* is the scale suitable for sheet *A*, and scale *B* the one suitable for sheets *B*, *C*, *D* and *E*. See Unit I.

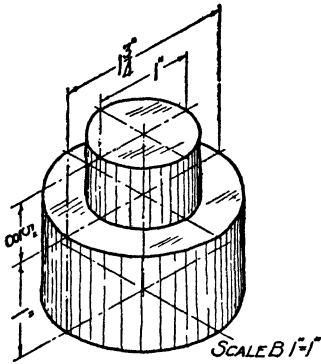

FIG. 9. Plinth block.

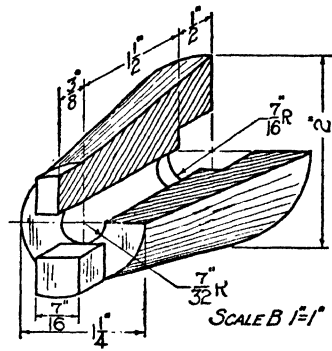

FIG. 10. Conical block.

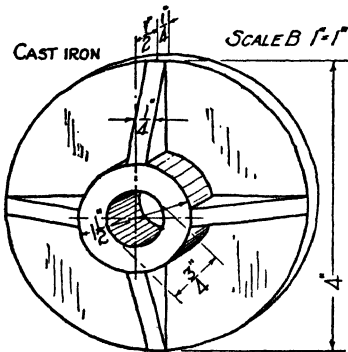

FIG. 11. Washer.

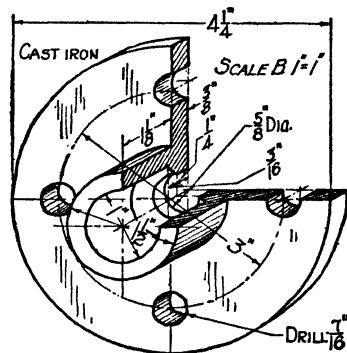

FIG. 12. Stuffing box body.

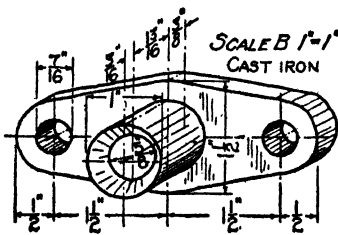

FIG. 13. Packing gland.

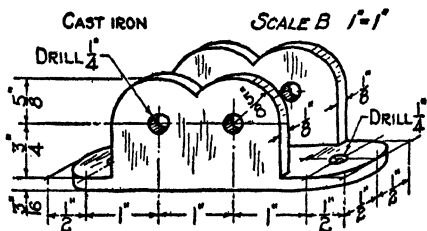

FIG. 14. Sharpener frame.

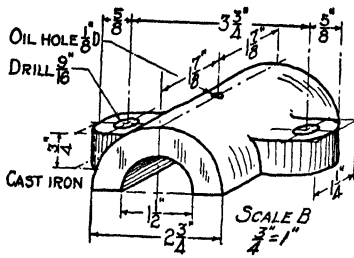

FIG. 15. Bearing cap.

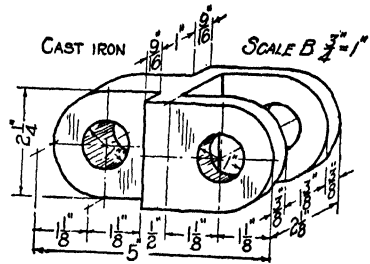

FIG. 16. Chain link

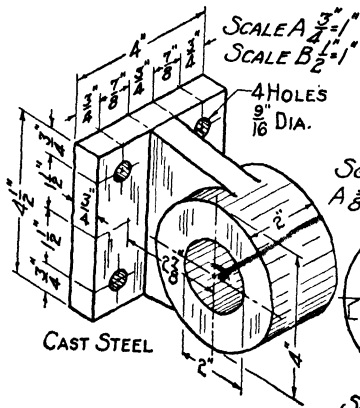

FIG. 17. Control rod bracket.

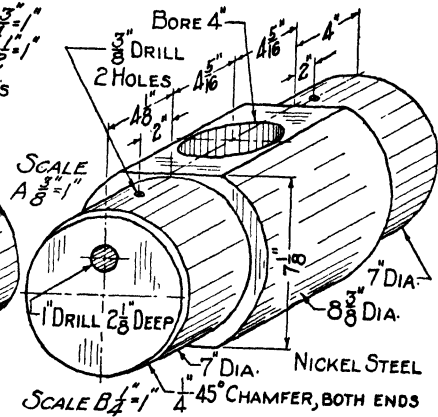

FIG. 18. Pin.

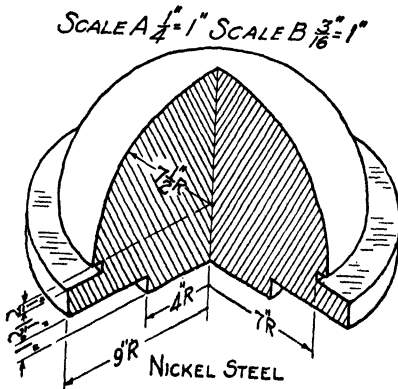

FIG. 19. Pintle.

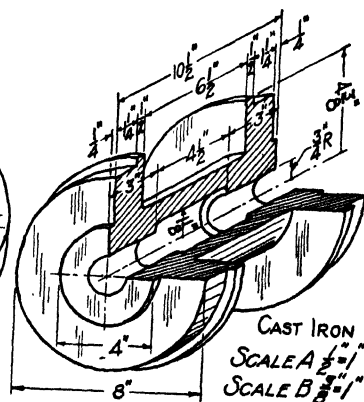

FIG. 20. Roller.

UNIT IX

ORTHOGRAPHIC PROJECTION. THREE VIEWS

PURPOSE OF UNIT IX

The purpose of this unit is to show how to determine when a third view of an object is required and how to make it when the top and front views are given.

WHAT YOU SHOULD KNOW ABOUT THE SIDE VIEW

As was stated in Unit VII, the purpose of a working drawing is to describe with accuracy and exactness the size and shape of objects which are to be manufactured or built. Now it sometimes happens that two views of an object will not suffice to make perfectly clear just what its actual shape is. Usually, a third view will make this clear. In other words,

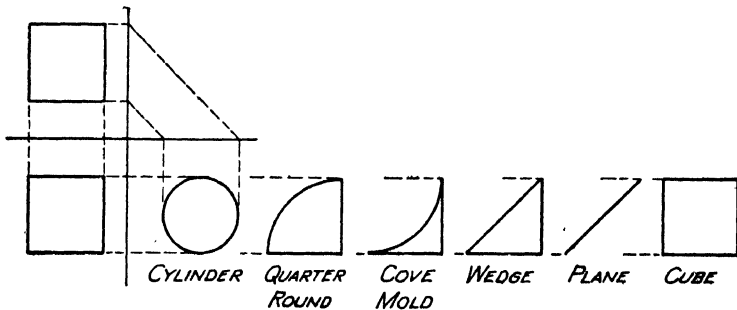

FIG. 1. Possible interpretations of front and top views when side view is not shown.

if the front and top views of an object do not completely define its shape, the object may also be viewed from the right or left side in order to get further information.

To illustrate the need for a third view it may be noted that so simple an object as a cube is not absolutely determined in shape by the front and top views alone, unless all corners are designated by letters, a thing which is not

done in working drawings. If the front and top views of a cube only are shown, these two projections may represent any one of six different shapes so far as these views alone are concerned, as may be observed by examining the six sketches in Fig. 1.

Figure 2 also shows an object of which it will be necessary to show the top, front and right side views in order to describe it adequately, since neither the top nor front view will show the shape of the rounded front end or whether the two holes are round or square.

We may, therefore, put it down as a rule that, whenever two views fail to describe the shape of an object exactly, a third view should be made.

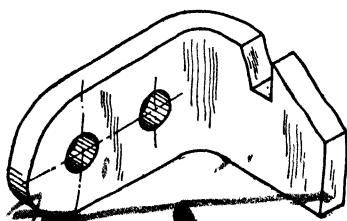

FIG. 2. Latch bar.

Position of the third plane.

The third or side view is made in the same manner as the other two views, namely, by setting up a plane of projection and representing the object upon it as it appears from the side. The

point of sight is again at infinity, so that the lines of sight will be parallel. These lines are perpendicular to the plane as required by the definition of orthographic projection. This third plane is called the *profile plane*, and it is perpendicular to the horizontal and vertical planes. We now have three planes of projection mutually at right angles to each other, like the top, front and right side of a box. This arrangement is shown pictorially in Fig. 3 with the object of Fig. 2 shown inside the box and the three projections or views shown in the sides of the box which represent the three planes of projection.

In representing these three views upon one flat piece of paper, the front and top views will be drawn in the usual manner and then the third view constructed from them in its proper position. A comparison of Figs. 3 and 4 will show that, when the draftsman is looking down upon the object,

the two ground lines represent the vertical and profile planes seen edgewise, and when he is looking at the front of the object, the horizontal and profile planes are seen edgewise. In looking at the side the vertical and horizontal planes are seen edgewise. It would be a waste of time and space, however, to draw these lines representing the planes or faces of the box separately in each view when the same thing can be accomplished much more conveniently by making these

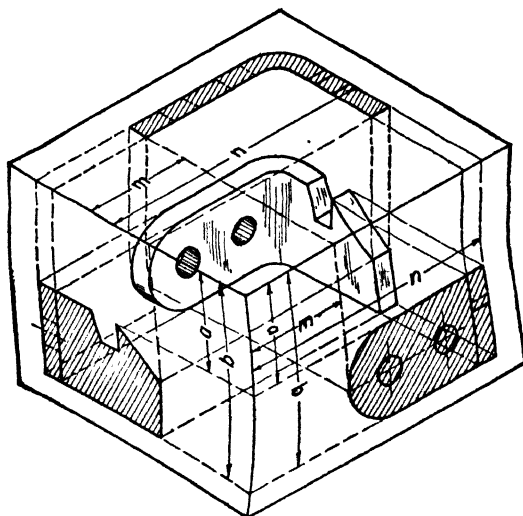

FIG. 3. Pictorial view of object and three projections.

lines coincide and thus having only two ground lines at right angles to each other as in Fig. 5. The distances m and n can now be transferred from the top to the side view by means of the T-square and triangle instead of with the dividers as shown in Fig. 5.

From the drawing just studied, the following rules, which form a part of what are called the *principles of projection*, can be observed.

1. The top and front views of an object are always in vertical alignment, that is, the top and front views of any point on the object always lie in the same perpendicular to the horizontal ground line.

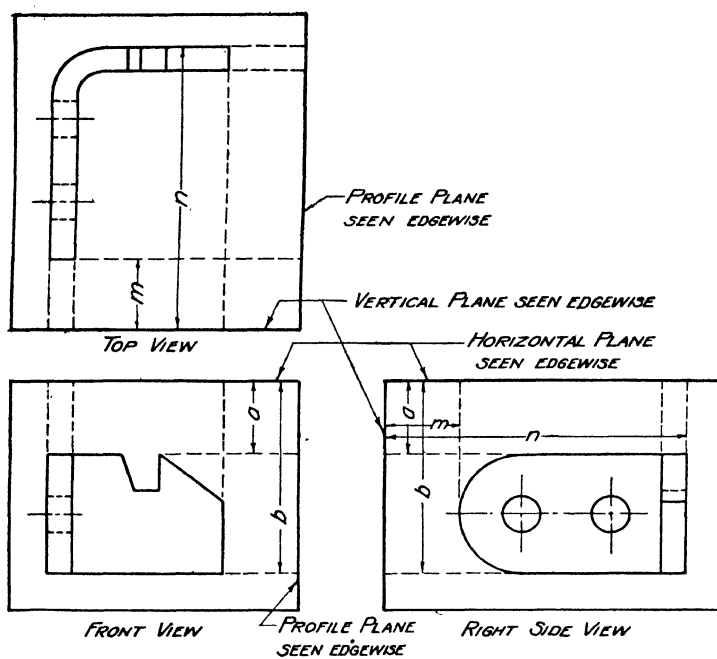

FIG. 4. Top, front and side views of bar and planes of projection.

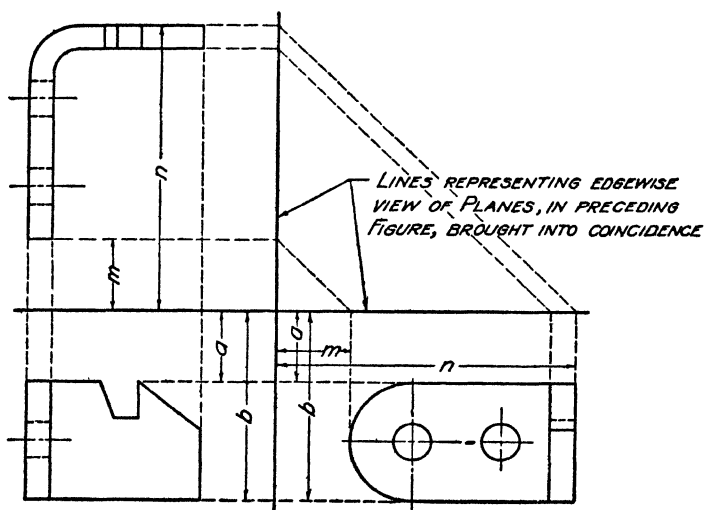

FIG. 5. Three orthographic views of bar combined.

2. The front and side views of an object are in horizontal alignment, that is, the front and profile views of any point on an object lie in the same perpendicular to the profile ground line.
3. The side view of any point is just as far to the right of the profile ground line (for a right side view) as the top view of the point is above the horizontal ground line.

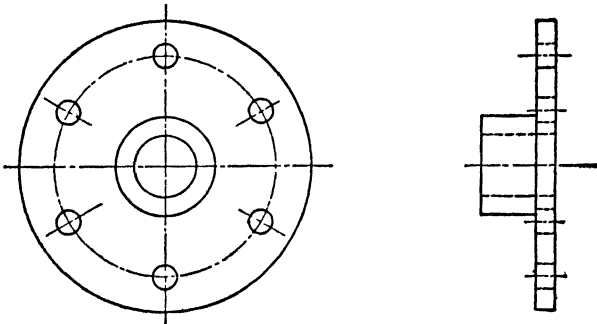

FIG. 6. Front and side views of end plate.

Choice of views. Although some objects require three views, many may be adequately shown with two views if some other choice than front and top views is available. With the addition of the third plane, therefore, we not only have increased our power of describing the shape of objects but in addition have secured a wider range of choice when only two views are necessary. We may now make not only the top and front views but also a front and side view as shown in Fig. 6. This is sometimes quite advantageous.

HOW TO DRAW THE SIDE VIEW

To make the side view when the top and front views are given. Obtain the side view point by point by projection from the other two views. The method of construction is shown in Fig. 7, where a truncated right square pyramid is shown by its front and top views with all corners lettered for convenience. To get the side view of the point *A* draw a light line horizontally across from *a'*. Next draw a line

horizontally from a in the top view to the profile ground line. Transfer the point thus found to the horizontal ground line by means of a 45-degree line. Project from this point vertically downward until the line from a' is intersected, thus locating a_2 .

Repeat this process for each point of the figure, and connect the points thus found in their proper order as shown

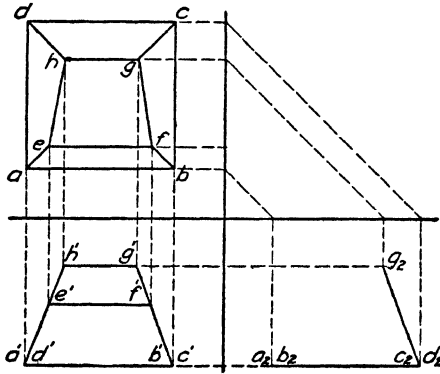

FIG. 7. Constructing side view from front and top views.

in the other views. The side view has been left incomplete to bring out the construction more clearly.

QUESTIONS

1. If two views of an object are inadequate to describe an object completely, what may be done about it?
2. Show by a sketch why two views of a cube are not enough to describe it completely if the views are not lettered.
3. How is the third plane of projection placed with reference to the horizontal and vertical planes?
4. What name is given to the third plane of projection?
5. Show by a sketch how the dimensions of the top view may be transferred to the side view.
6. What are the objections to making more views of an object than are required?
7. What dimensions are shown in the top view of an object?
8. What dimensions are shown in the front view of an object?
9. Show by a sketch the proper position of the three views of an object to each other. Use top, front and right side views.

10. By what other name is the side view of an object sometimes called?
11. What is the relationship of the object, plane of projection and point of sight to each other?
12. When only two views of an object are to be made, what combinations of views may be used?
13. What dimensions are shown in the profile view of an object?

PROBLEMS

Draw first the standard border line and title space, then do the problems assigned from the following group. Place one problem on a sheet. Proceed in the manner indicated below.

1. After drawing the border line and title space locate and draw in the horizontal and vertical ground lines as indicated for the problem assigned. These ground lines are located from the center lines of the clear drawing area inside the border line. The symbol ϕ means center line.

2. Next, reproduce the top and front views in the positions indicated, but do not put in any of the dimensions on your drawing. They are given simply to aid you in getting a well-balanced sheet.

3. Construct the side view of the object, using very light, solid lines for your projecting lines. After the third view is complete, go over all views with a 2H pencil and make them stand out clearly above the projecting lines. Do not draw the small pictorial sketch. This is introduced merely to aid you in reading the two-view orthographic drawing.

4. Submit your drawing to the instructor for approval and suggestions. Make changes and corrections indicated.

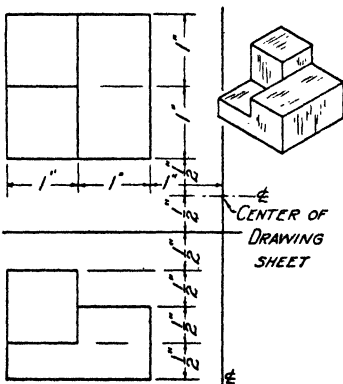

FIG. 8. Stepped block.

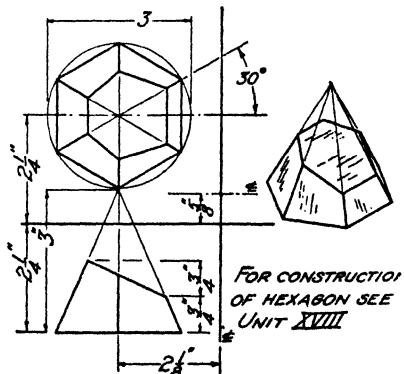

FIG. 9. Truncated pyramid.

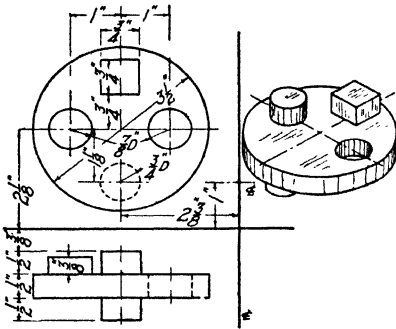

FIG. 10. Circular block.

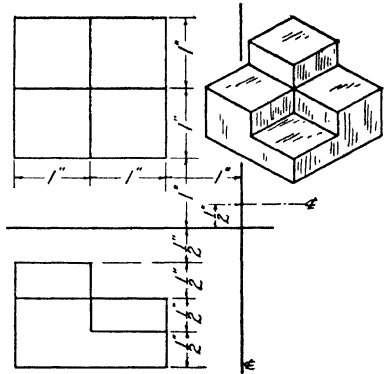

FIG. 11. Stepped block.

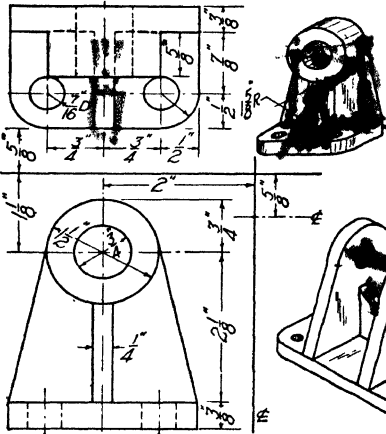

FIG. 12. Bearing bracket.

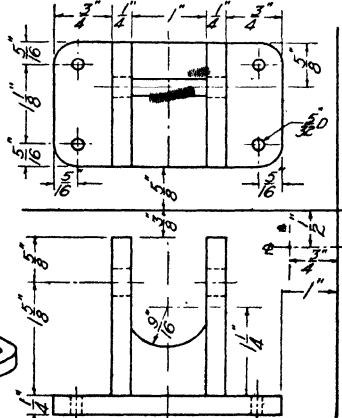

FIG. 13. Bracket.

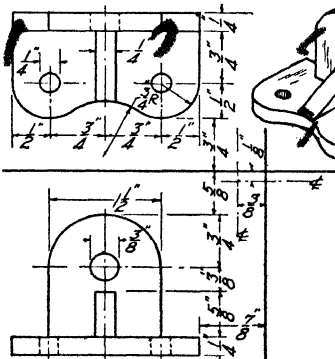

FIG. 14. Swivel bracket.

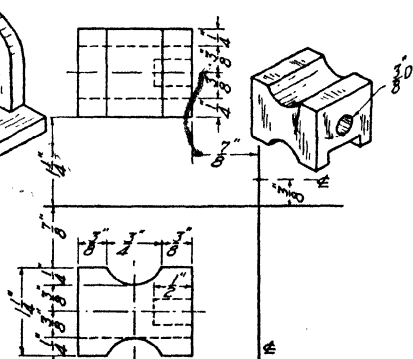

FIG. 15. Clamp block.

UNIT X

ORTHOGRAPHIC PROJECTION. READING DRAWINGS

PURPOSE OF UNIT X

The purpose of this unit is to show how to construct any one of the three principal views when the other two are given, and to show how to read a drawing.

WHAT YOU SHOULD KNOW ABOUT ORTHOGRAPHIC VIEWS

In the preceding unit it was made clear that three views of an object should be made only when it is necessary to do so in order to show the shape of the object. For purposes of study, however, we shall make three views of various objects even though, as a matter of shape description, they may not require it, because experience in making three views is best gained in handling familiar and simple objects.

Marking of views. For convenience in reference it is necessary to mark the views of objects in some characteristic way, so that the markings will always have the same meanings. The *H*, *V* and *P* planes are designated by the numbers 0, 1 and 2 in consecutive order. The ground line representing the intersection of any two planes is given the numbers of both planes. Thus the horizontal ground line will always be 0-1 and the profile ground line 1-2. A point on an object is represented by a capital letter and its projections by small letters, subscripts corresponding to the number of the plane on which they lie. Thus, in Fig. 1, capital *A* would refer to a corner on the truncated pyramid shown in the projections a_0 , or just *a* without the zero, which represents the projection of *A* on *H*, while a_1 represents the projection of *A* on *V*, and a_2 represents the projection of

A on *P*. This is a system of notation which is rather widely used.

What each view tells. The top view shows the relationship of the object to the vertical and profile planes. That is to say, from the top view we can tell how far a point is behind the vertical plane and how far one point on the object is behind another. We can also tell how far a point is to the right or left of the profile plane, or how far a point is to the right or left of any other point of the object. Thus, in the top view of Fig. 1, *b* is $\frac{1}{2}$ inch behind *a*, and it is $\frac{1}{8}$ inch to the right of *a*.

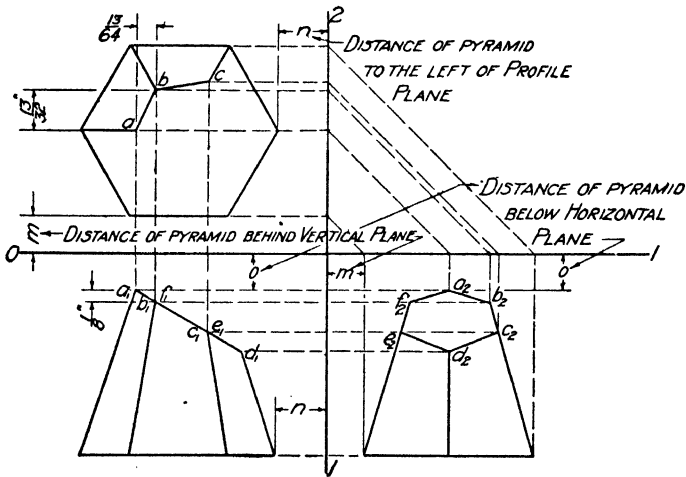

FIG. 1. Constructing top view from front and side views.

The front view shows the relationship of the object to the horizontal plane and to the profile plane. From the front view we can tell how far below the horizontal plane any point is, or how far one point is above or below another. Thus, in the front view of Fig. 1, *b* is $\frac{1}{8}$ inch below *a*. The relationship to the profile is repeated; hence the top and front views must be exactly one above the other, since the distance of any point from the profile plane must be the same in both views.

The profile view shows the relationship of the object to

the horizontal and vertical planes. The relationship to the horizontal plane was also shown in the front view; hence the profile view must be exactly the same distance below the ground line as the front view, that is, the two views must be in perfect horizontal alignment. The profile view also shows the distance from the vertical plane, as does the top view; hence these two views must tell the same story. Thus the distance m from the vertical plane in the top view, must be the same as the distance m , from the vertical plane in the side view. This fact accounts for using the 45-degree construction lines in transferring this distance from top to side view or, vice versa, from side to top view.

Omitting ground lines. In drawings which are to be dimensioned for use in shops, ground lines are never shown. But, since we always place the faces of our objects parallel to the principal planes of projection, these faces could be used as planes of reference just as well as the principal planes. The relationship between views as discussed above still holds, but instead of locating a point with reference to the planes of projection and their corresponding ground lines, we locate them with reference to some plane face of the object, which is, of course, just the thing which a mechanic must do in constructing the object. This scheme necessitates the use of dividers or the scale in transferring measurements from the top to the side view; otherwise the construction of views is in all respects the same as if the ground lines were used.

HOW TO FIND A THIRD VIEW WHEN TWO VIEWS ARE GIVEN

To construct the top view from the front and side views. Any view must be constructed point by point. Use the truncated hexagonal pyramid of Fig. 1 as an example. To locate point a , erect a perpendicular from a_1 of indefinite length. From a_2 erect a perpendicular to the ground line, then transfer this distance to the profile ground line by means of a 45-degree construction line. From this point on 1-2 draw a horizontal line until it crosses the perpendicular from a_1 . This intersection locates a . All other points in the

top view are found in the same manner. To complete the view, connect them in proper order. The top view in Fig. 1 has been left incomplete to make the construction more evident.

To construct the front from the top and side views. This construction requires the least work of all, since a point in the front view is directly below its projection in the top view and directly across from its projection in the side view. Thus, in Fig. 2, to locate a_1 draw downward a perpendicular from a of random length. Then draw a horizontal line across from a_2 until it intersects this perpendicular. This intersec-

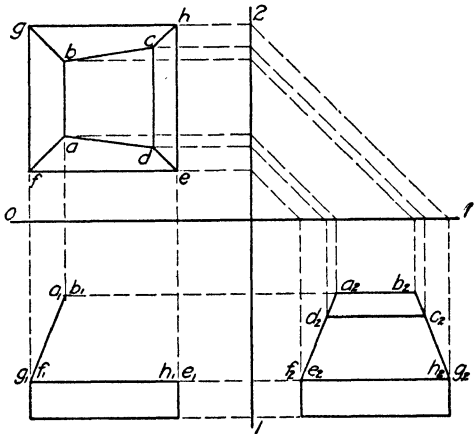

FIG. 2. Constructing front view from top and side views.

tion locates a_1 . All other points in the front view are located in the same manner. The front view has been purposely left incomplete.

To construct views from pictorial drawings. Two principles of geometry are very useful in drawing. They are as follows, and should be thoroughly learned.

1. If two parallel planes are intersected by a third plane, their intersections are parallel.
2. If two lines are parallel, their projections on any plane are parallel.

Figure 3 represents an object in the drawing of which

both of these principles must be employed. An examination of the illustration shows that the right side, the two vertical faces of the groove and the left side are four parallel planes. The bottom of the groove and the top of the object are also parallel planes. Hence, by rule 1 above, the lines AD , BC and EF are parallel, and HE and AB are parallel. To make the drawing, proceed as follows:

Lay out the rectangles for all three views in their proper relation to each other.

Complete the front view by drawing the diagonal line h_1f_1 and the groove which appears $\frac{3}{8}$ inch deep and $\frac{1}{2}$ inch wide.

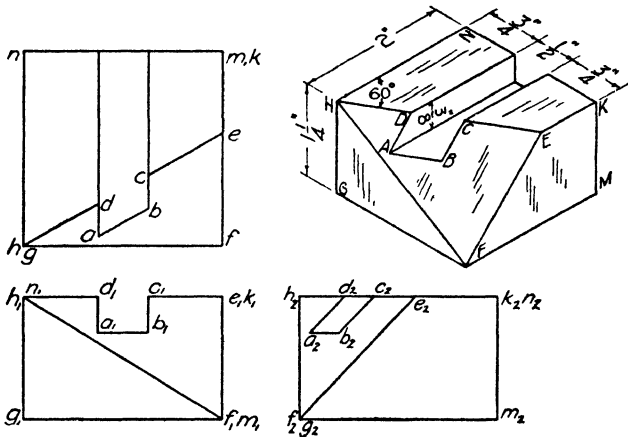

FIG. 3. Geometrical rules used in constructing views.

In the top view, draw the diagonal line he and the two lines representing the vertical faces of the groove. The points d and c are thus located, but the points a and b cannot be determined. Hence we turn to the side view. Locate the point e_2 by projection from the top view, and draw the diagonal line e_2f_2 . Then locate d_2 and c_2 by projection from the top view.

The lines c_2b_2 and a_2d_2 can now be drawn in the side view by rule 2 above. Since they are parallel to EF , their projections will be parallel to e_2f_2 .

Draw lines from d_2 and c_2 parallel to e_2f_2 and terminate

them upon a horizontal line projected across from a_1 and b_1 , thus locating a_2 and b_2 . Now project these points back to the top view, thus locating a and b and completing the figure.

HOW TO READ TWO AND THREE VIEW DRAWINGS

A method of testing the ability to read and understand two- and three-view drawings is to make sketches of them in isometric or other pictorial form as described in Unit XV. The method of sketching described in that unit can be simplified by using commercial isometric* coordinate paper.

This paper not only makes it easy to draw along or parallel to the three coordinate lines, but also enables one to estimate measurements more easily and accurately.

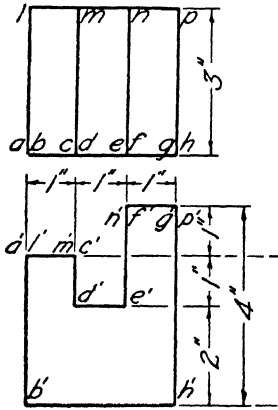

FIG. 4

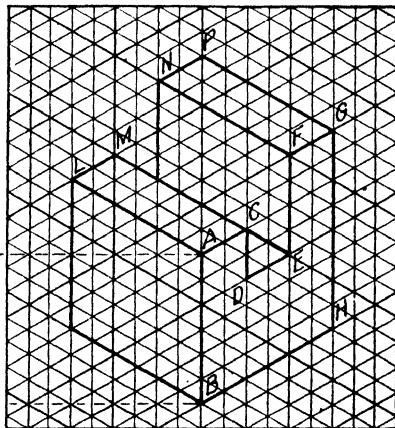

FIG. 5

To make pictorial drawings on isometric paper. In Fig. 4 two views of a dimensioned block are shown with a few of the corners lettered for convenience. This block will be shown to best advantage in the pictorial view if the edge AB is made the front corner.

Consider the smallest unit of measurement on the co-

* Those who prefer perspective sketches can obtain a paper with coordinates printed in perspective form from Frank W. Walsh, Box 432, Oshkosh, Wisconsin.

ordinate paper in Fig. 5 as $\frac{1}{2}$ inch. Then draw AB in Fig. 5, shown by projection $a'b'$ of Fig. 4, six units long, thus making it represent 3 inches. Other vertical lines on either the front or side view of the block will appear as vertical lines on the coordinate paper.

Then draw the horizontal line AC , shown at $a'c'$ in the front view (Fig. 4), two units long up to the right along the ruled lines in the pictorial view. Draw all horizontal lines running in the same direction in the front and top views in the same direction as AC in the pictorial view.

Draw AL upward to the left along the coordinate lines to represent al in the top view and $a'l'$ in the front view. In the same way draw all horizontal lines running in the same direction as al parallel to AL , and all vertical lines in the pictorial view parallel to AB .

Having drawn the three edges, AB , AC and AL , try to visualize them as three mutually perpendicular lines and continue with the other lines of the figure in order. Thus, from the front and top views of Fig. 4, draw CD downward two units, DE up to the right two units, EF vertically upward four units, FG two units up to the right, GH downward eight units and HB down to the left six units, thus closing back on A and completing one face of the block.

Then draw AL , CM , FN and GP , which are at right angles to the front face, up to the left the proper distance and complete the figure by drawing the remaining lines. Unless they are absolutely necessary to an understanding of the figure, omit invisible lines.

To draw objects with diagonal lines. In Fig. 6 is shown an object in which several of the bounding edges do not fall on the coordinate lines of the ruled paper. With lines such as AB , CD , EF and FG it is necessary to plot the end points by rectangular coordinates and then connect the points, thus locating the diagonal lines. If we begin with line AD which can be drawn on a coordinate line sloping up to the right six units, the point B will be over to the right one unit, two units to the left of A , and vertically up three units. These

dimensions are shown by the dash lines in Fig. 7. *A* and *B* should then be connected by a straight line. Plot other diagonal lines in the same way.

To draw objects with curved lines. When drawings of objects involving curved lines are to be sketched in pictorial form, follow the procedure outlined in Unit XV, page 146,

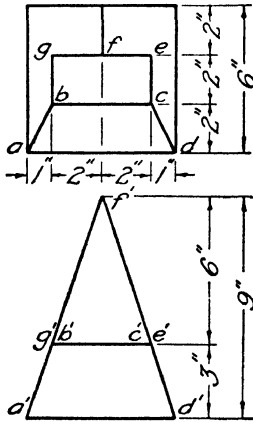

FIG. 6

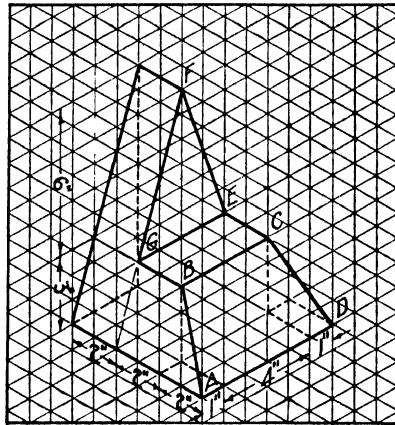

FIG. 7

using the coordinate paper again as an aid in blocking out the curves.

QUESTIONS

1. When letters are used to designate points on an object, how are the different projections marked? Illustrate.
2. What numbers are assigned to the *H*, *V* and *P* planes, respectively, in working out a marking system?
3. By what numbers is the ground line, representing the intersection of any two planes, designated?
4. What information relative to the position of points on an object can be obtained from the top view?
5. What information concerning the relative position of points on an object can be obtained from the front view?
6. What information concerning the relative position of points on an object can be obtained from the side or profile view?
7. Explain why ground lines may be omitted in the construction of drawings.

8. When the ground lines are omitted in the construction of a drawing, how are measurements transferred from the top to the side view?
9. Does the omission of the ground lines permit of any change in the relative positions of the three views? If so, what change?
10. If two parallel planes are intersected by a third plane, what do we know about the two lines of intersection?
11. If two lines of an object are parallel, what do we know about their projections on any and all views?
12. Illustrate by a freehand sketch how three dimensions may be shown in a one-view drawing.
13. What are drawings which show three dimensions in one view called? Give as many names for them as you can.
14. Show by a freehand sketch on isometric coordinate paper how to draw a circle. Indicate all steps in the procedure.
15. Indicate by a freehand sketch on isometric coordinate paper how to draw a short cylinder. Indicate all the steps in the process.

PROBLEMS

Three groups of problems follow. The first group, Figs. 8 to 19 inclusive, is for the purpose of exercise in constructing three views from the given pictorial view. For these problems lay out the standard border line and title space and then make three views of one of the objects assigned. Make the views with or without the aid of ground lines as directed by your instructor.

The second group, Figs. 20 to 29, is for exercise in the reading of two- and three-view drawings by making pictorial views on isometric coordinate paper. For these problems the point marked *A* shall be the lower front corner of the object and the object shall be drawn in the position shown in the text. Select your scale (value of a unit on the paper) so that the drawing will be of reasonable size. Further problems of this kind may be found on pages 175 and 176.

The third group, Figs. 30 to 35, is for practise in constructing a third view from two given views. Reconstruct the two given views at a suitable scale and then make the third view by projection from the two given views.

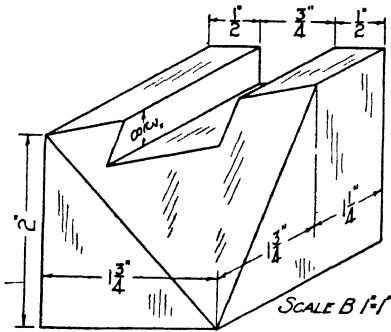

FIG. 8. Block.

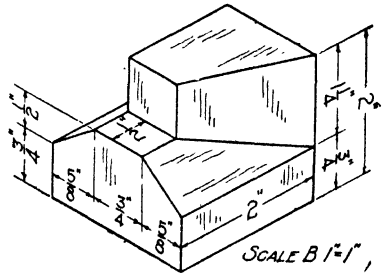

FIG. 9. Block.

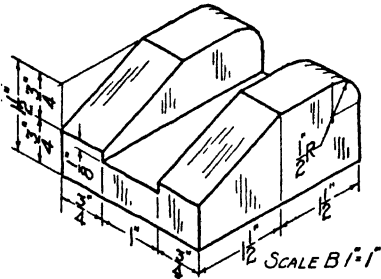

FIG. 10. Grooved block.

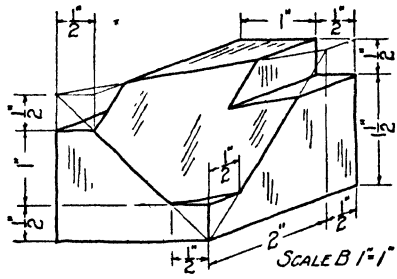

FIG. 11. Beveled block.

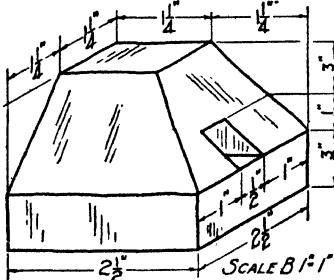

FIG. 12. Block.

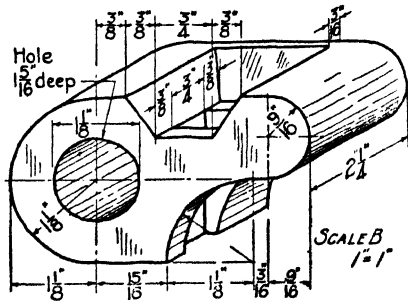

FIG. 13. Block.

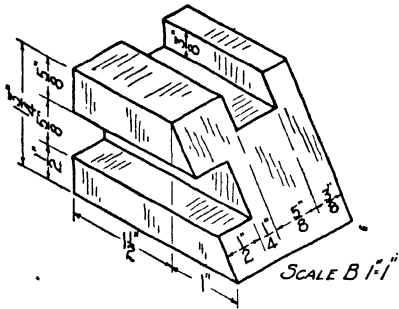

FIG. 14. Block.

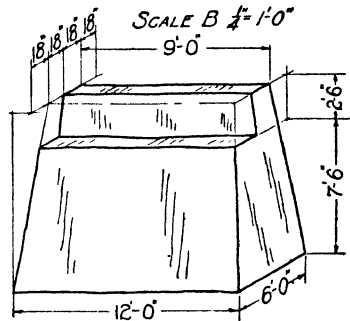

FIG. 15. Abutment.

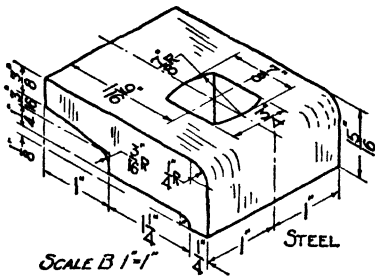

FIG. 16. Rail clip.

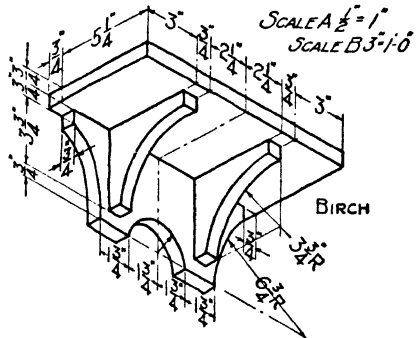

FIG. 17. Shelf.

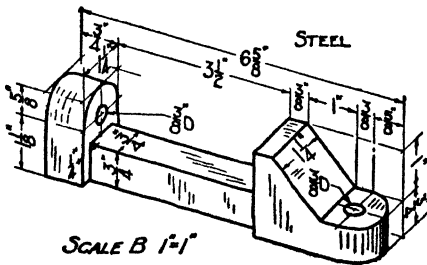

FIG. 18. Drill clamp body.

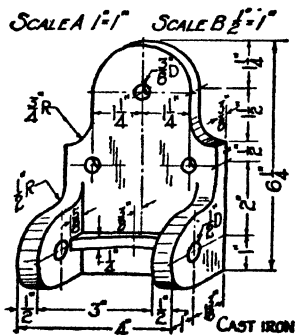

FIG. 19. Hinge bracket.

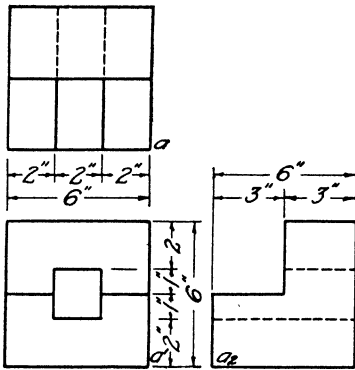

FIG. 20

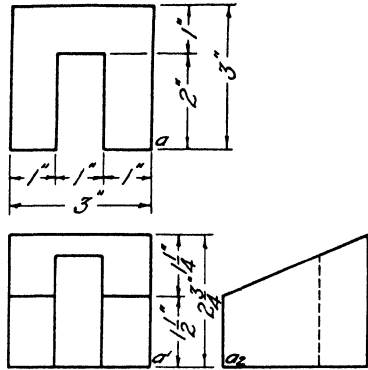

FIG. 21

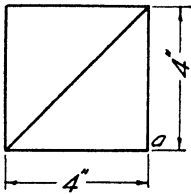

FIG. 22

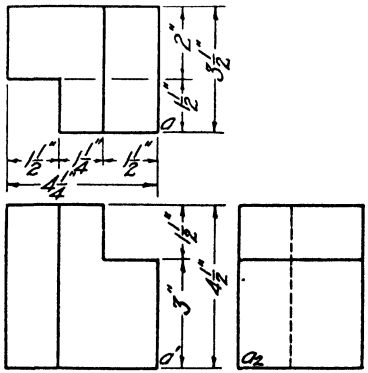

FIG. 23

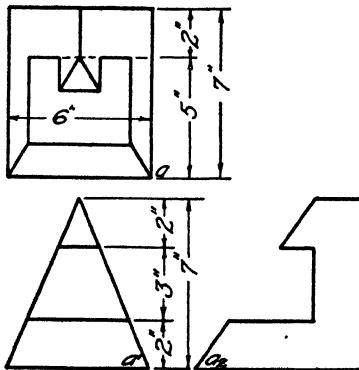

FIG. 24

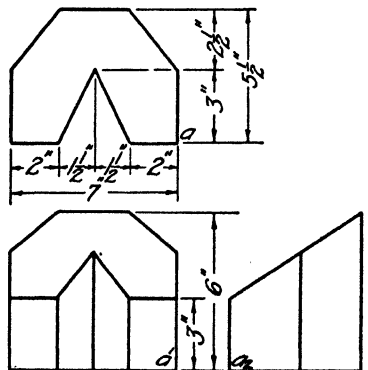

FIG. 25

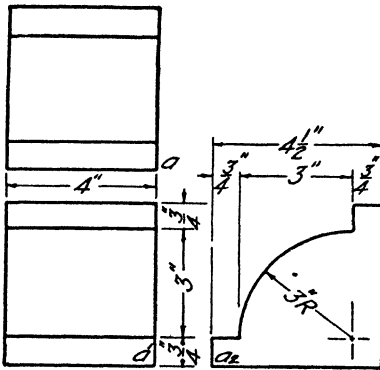

FIG. 26. Block.

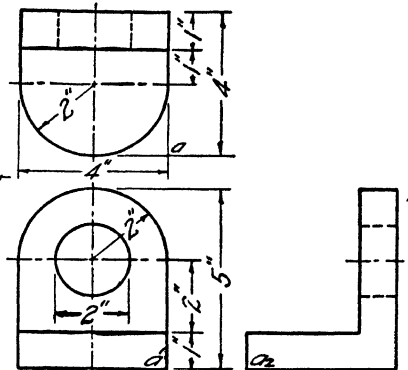

FIG. 27. Block.

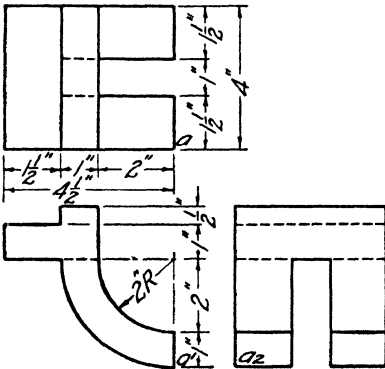

FIG. 28. Block.

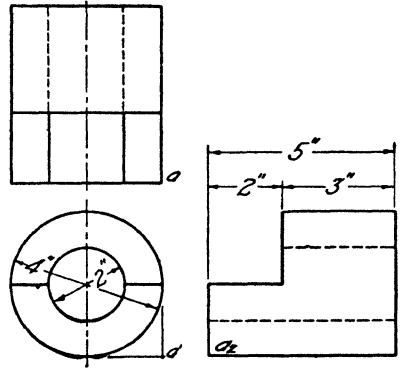

FIG. 29. Block.

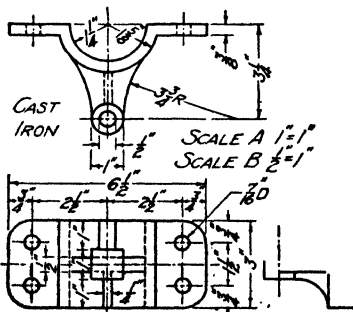

FIG. 30. Reel bracket.

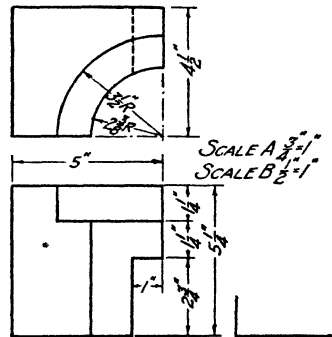

FIG. 31. Block.

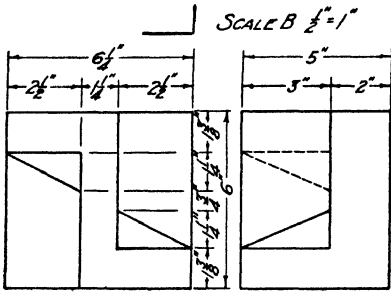

FIG. 32. Block.

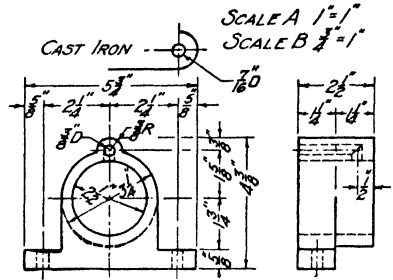

FIG. 33. Bearing.

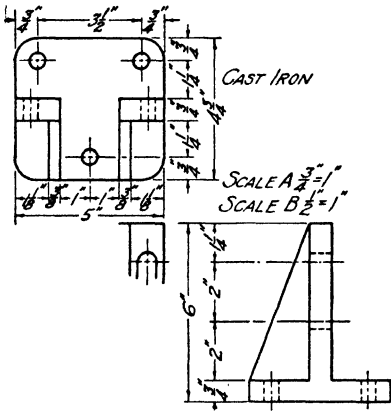

FIG. 34. Adjustable bearing support.

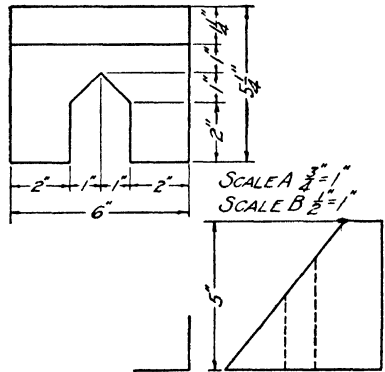

FIG. 35. Block.

UNIT XI

WORKING DRAWINGS. MECHANICS OF DIMENSIONING

PURPOSE OF UNIT XI

The purpose of this unit is to teach the meaning of the terms "working drawing" and the "mechanics of dimensioning," and the placing of dimensions on working drawings.

WHAT YOU SHOULD KNOW ABOUT WORKING DRAWINGS AND THE MECHANICS OF DIMENSIONING

Purpose of working drawings. In the commercial world, drawings are made for the purpose of manufacturing or constructing useful objects. In order to make an object of any kind the workman must know not only its shape but also its exact size, the materials of which it is to be made, how it is to be finished and many other bits of information which cannot be shown in orthographic views.

The orthographic projections will define the shape of an object exactly, but before the projections can be used for construction they must have added to them all necessary dimensions to determine the size of all parts and their relationship one to another, with notes giving all other information necessary for construction.

A working drawing, or shop drawing as it is sometimes called, may then be defined as a drawing containing an adequate number of views of an object completely dimensioned and having sufficient notes to enable one to make the object without further information. In machine drawing it is the usual practise to draw each part of a machine on a sheet by itself. Such drawings are sometimes called "detail working drawings," or simply "detail drawings." The same term is also used in architectural, structural and other kinds

of drawing, as, for example, when a unit of the structure, such as a window, door or steel column, is drawn by itself to show the details of construction.

Dimensioning. The art of dimensioning a drawing divides itself naturally into two phases. The first of these may be called the mechanics of dimensioning, which is concerned with the appearance of the drawing sheet from the standpoint of neatness, legibility and clearness of meaning. The second phase deals with the study of the dimensions needed for construction. This unit will deal only with the first of these phases.

The major consideration in dimensioning, as it is in the drawing of the views, is clearness of meaning. Dimensions must be of such a size and must be so placed that they cannot be misinterpreted. Experience has dictated certain well-defined rules, which, if carefully observed, will greatly assist in the rapid production of legible drawings. These rules are arranged in two easily remembered groups.

TECHNIQUE OF DIMENSIONING

1. All lines used for the purpose of dimensioning should be light, clear, firm lines of the same weight as center lines, as shown in Fig. 1.

2. Witness lines, or extension lines, as they are sometimes called, should be brought almost up to the object but not quite touching it. The break between object and witness lines should be about $\frac{1}{8}$ inch. Where it is necessary to carry a witness line across a part of the object the witness line should be broken. See Fig. 1.

3. Arrow-heads must be placed on each end of the dimension lines and should always touch the witness lines. The size of the arrow will vary with the general size of the drawing and with the space available for the dimension. The arrow should be fairly long and pointed and solid black, as shown in Fig. 1. An enlarged view of the arrow illustrating the method of construction is shown in Fig. 1a.

4. Notes on a drawing are connected to the parts to which

they apply by leaders. The arrow of the leader should touch the part to which it applies; the other end should terminate in a short horizontal line at the mid-height of the line of lettering, as shown in Fig. 1.

5. For machine drawing, the dimension line should be broken and the number placed in the gap so that the dimension line, if produced, would strike it at mid-height. If the dimension contains a fraction, the bar separating the numerator and denominator should be drawn in line with the dimension line but should not be a part of it. Attention is again called to the fact that the numbers in a fraction are

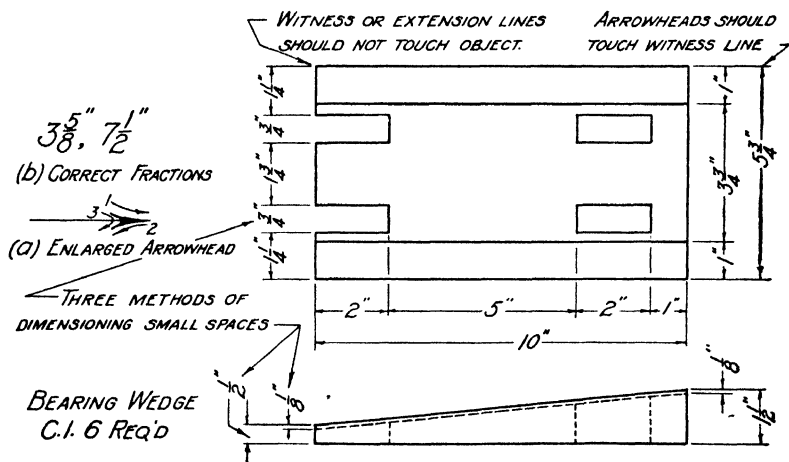

FIG. 1. Dimensioning of bearing wedge.

two-thirds the height of the whole numbers. See Fig. 1 for illustration of points discussed in this paragraph. The large size dimension, Fig. 1b, indicates the proper way in which the whole number and fraction should be made. Note that the center line of the fraction has the same slope as the whole number.

6. The numbers themselves would be meaningless unless there were some way to indicate what they mean in terms of length, whether yards, feet or inches. Only the latter two units are used in drawings, and they are indicated by sym-

bol. One short stroke above and to the right of the figure designates feet; two short strokes in the same position indicate inches. If only inches are used in dimensioning, the symbol may be omitted entirely. This is done in some shops.

Although the American Standards Association indicates that the practice of omitting inch marks, when all dimensions are in inches, is preferable, recent rather extensive surveys (1932* and 1940†) indicate that there is a wide divergence of practise throughout the country. Inclusion of inch marks, even though one is omitted now and then, can cause no confusion and is on the conservative side in practise. Figs.

| | | | |
|---|--------------------|-----|-------------------|
| <i>INCHES ONLY</i> _____ | $3''$ | NOT | $0'3''$ |
| <i>FRACTIONAL INCH ONLY</i> _____ | $2\frac{1}{2}''$ | " | $0\frac{1}{2}''$ |
| <i>FEET AND INCHES</i> _____ | $2'3''$ | | |
| <i>FEET AND FRACTION OF AN INCH</i> _____ | $4'0\frac{1}{2}''$ | NOT | $4'\frac{1}{2}''$ |
| <i>FEET ONLY</i> _____ | $3'-0''$ | " | $3'$ |

FIG. 2. Methods of marking dimensions.

4 and 5 illustrate dimensioning without the inch marks. Figure 2 illustrates the practise when the symbols are used.

POSITION OF DIMENSIONS ON A DRAWING

1. Dimensions on a drawing should be read from left to right horizontally. This corresponds to the way we read all printed matter.

2. Some dimensions, however, are in a vertical direction and so cannot be arranged as in rule 1. These dimensions should read from the bottom toward the top. In other words, it should be possible to read every dimension on a drawing from either the bottom or right side.

Diameters and radii of arcs and circles are an exception to this rule, since they must never be placed along center lines. They should, however, be placed at as small an angle

* "A Survey of Drafting Room Practise" by F. R. Kepler, Board of Education, Detroit, Mich., 1932.

† "Drafting Room Practises" by T. C. Brown and P. E. Moose, Bull. 21, Engg. Exp. Sta., State College Station, Raleigh, N. C.

with the horizontal and vertical as possible, as illustrated in Fig. 3.

3. Dimensions should be kept off the views of the object as much as possible. Diameters and radii of arcs and circles are again an exception to this rule. The purpose of this rule is to permit the shape of the object as shown in the several views to stand out as clearly as possible.

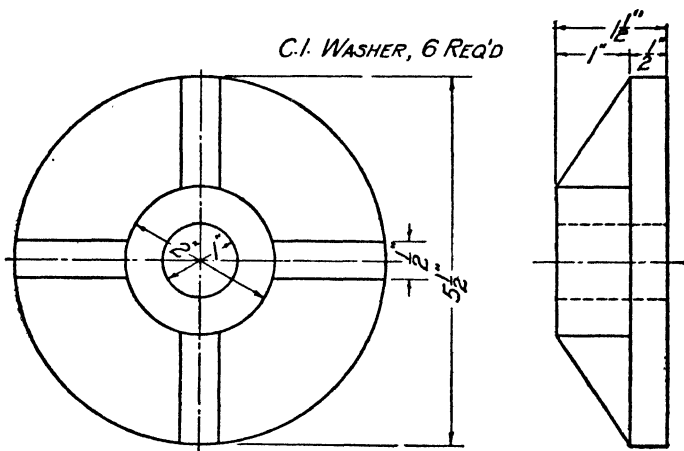

FIG. 3. Dimensioning circles.

4. For the same reason, the dimensions should be kept away from the views of the object at least $\frac{1}{2}$ inch. Rules 3 and 4, if carefully observed, make it possible for the views of the object to stand out clearly without being in the least obscured or confused by dimension lines.

5. For convenience in reading and to help establish the relationship between views the dimensions should, as far as possible, be placed between the views.

6. Unrelated dimensions should not be placed in the same series. They cannot be used without computation by the man in the shop and are, therefore, both inconvenient and subject to error.

7. Dimension lines should not cross. Crossing dimension lines spoils the appearance of drawings and makes for confusion in interpretation.

Three correct methods of dimensioning small spaces are illustrated in Fig. 1. Where a series of dimensions occur they should be placed in a straight line as in Fig. 1 and should be accompanied by an over-all dimension, except that the over-all need not be repeated on the same view. The dimension line must always be parallel to the line it dimensions, and its witness lines must be perpendicular to it.

It will be noted that many foregoing rules are not stated in absolute terms. This cannot be done, since the great variety of conditions arising in drawings cannot be covered by a few hard and fast rules from which no departure can be permitted. When a violation of the rules is contemplated, however, it must be only upon the condition of securing greater clearness in the reading of the drawing.

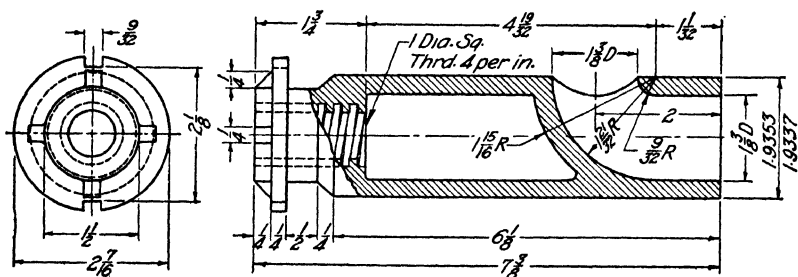

FIG. 4.

Figures 4 and 5 show two practical illustrations of dimensioning. In Fig. 4, for example, there are two series of dimensions, one above the right view and another below, together with the over-all. These could have been placed in one series, but this would have been incorrect since they are unrelated to each other in the construction. The series above gives the dimensions needed for the interior cores, which would have to be constructed to make a casting of this valve, and the series below gives the dimension necessary for construction of the outside form.

The 2-inch dimension at the right end was placed on the view in preference to crossing dimension lines which would have been necessary had it been placed above. The radii, of

course, may legitimately be placed on the view. Note that the two lines of dimensions below both views line up. Also, the dimensions at the right in Fig. 5 are in line on both views.

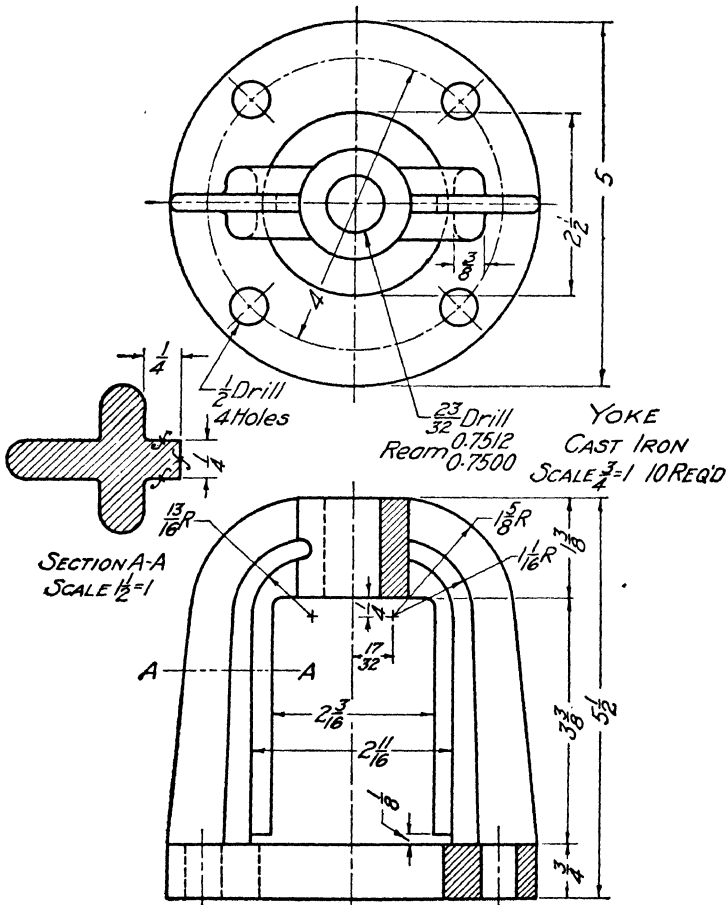

FIG. 5.

In Fig. 5 several dimensions have apparently been placed on the view. In reality they are all in a rather large opening in the object and do not confuse the drawing. In each case it would have been necessary to carry dimension lines through the view for a considerable distance to get the dimensions

on the outside. It will be noted that here the radii have been carried to a point outside the view.

These figures also illustrate points discussed in Units XI, XII and XIII, and should be referred to when studying those units.

HOW TO MAKE A DIMENSIONED DRAWING

Let it be required to make a dimensioned drawing of the object shown pictorially in Fig. 6a. Proceed as follows:

Decide first upon the number of views required. In this case, two will be sufficient. Lay out these orthographic views in the usual manner. Be careful to allow ample space be-

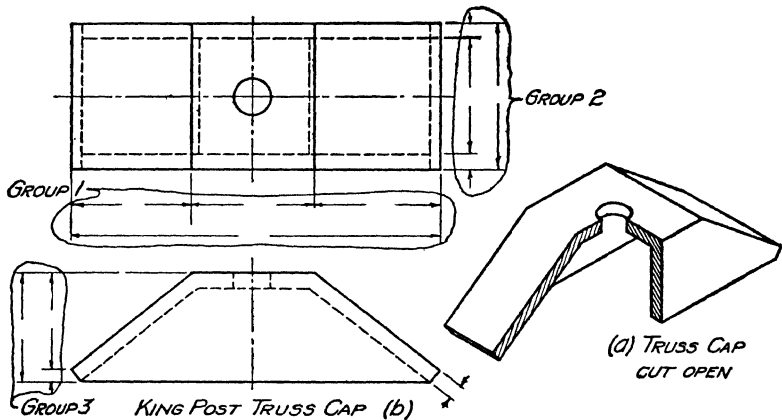

FIG. 6. Planning position of dimensions.

tween the views and between the views and border lines for the necessary dimensions.

Dimension first the top view, beginning with the length-wise dimensions. Draw witness lines from the points you intend to dimension, then draw the dimension lines making breaks in the lines for the figure. Place the detail dimensions nearest the object and the over-all dimension outside the detail dimensions. This prevents crossing of dimension lines. Put on the arrow-heads and insert the proper figures, thus completing the dimensions of group one. Proceed in the same manner for the width of the object, placing in the dimensions

of group two. This completes the dimensioning of the top view.

Take the front view next, and proceed as before, giving the height of all parts as shown in the dimensions of group three. Check over the drawing to see if any other dimensions are needed. In this case, the thickness of the metal in the front view is not shown by any of the dimensions thus far given and hence should be included. The most convenient place is at the right end. The size of the hole may be given by a note.

QUESTIONS

1. Define a working drawing.
2. What must be added to a correct orthographic view of an object to make a working drawing?
3. From which side, or sides, of the drawing sheet should one be able to read all dimensions?
4. Give four rules governing the location of dimensions.
5. If a choice is possible, should a dimension be placed upon a view or off it? Why?
6. Show by an enlarged sketch the proper shape of an arrow-head. What determines the proper size of an arrow-head for a drawing?
7. What should be the weight of dimension, extension or witness lines relative to visible and invisible outlines?
8. What is the reason for using lines of different weights for visible, invisible and dimension lines?
9. Why should witness lines not quite touch the outlines of the object itself?
10. Show by a sketch how a series of dimensions should be placed.
11. Why should dimensions not be placed too close to the object itself? About how far should the first dimension line be from the object?
12. Show how you would letter a dimension which is exactly 4 feet.
13. Show by an example how feet and inches are marked to distinguish them from each other.

PROBLEMS

Lay out the standard border line and title space; then make a dimensioned drawing of an assigned object from the following group. These drawings will not be complete working drawings since the necessary notes are for the present omitted.

Proceed in the following manner to make your drawing:

1. Study the object carefully and decide upon the necessary number of views to represent it clearly and adequately. Do not make more than necessary.
2. Block out the views by means of rectangles, which will just enclose them, to make a well-balanced sheet. Allow room between views for dimensions. It may be necessary to try out two or more arrangements of the rectangles. Do not hesitate to erase and try again until you have a well-balanced sheet.
3. Draw center lines in rectangles and lay out the views.
4. Dimension views according to the rules given in this unit.
5. The title of the sheet will be the name of the object drawn.

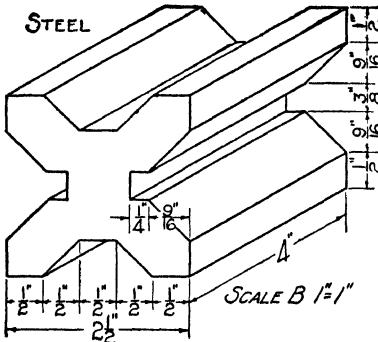

FIG. 7. Drill block.

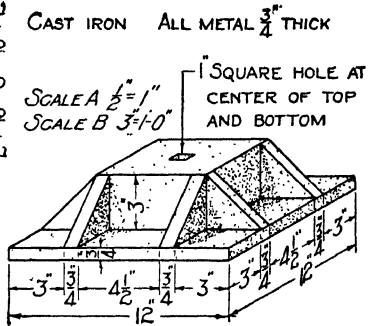

FIG. 8. Column base.

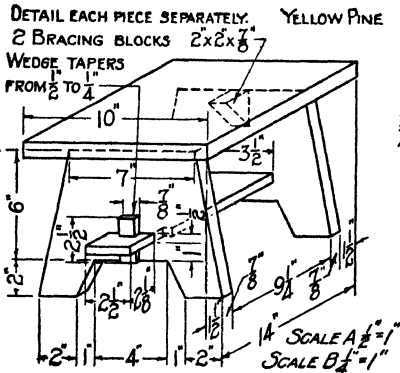

FIG. 9. Foot stool.

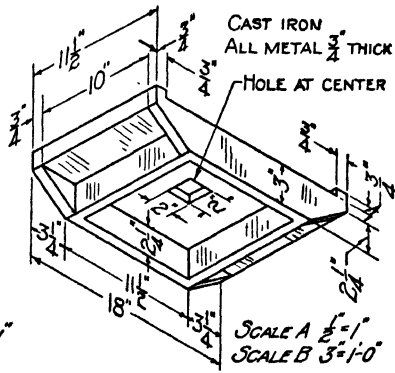

FIG. 10. Post cap.

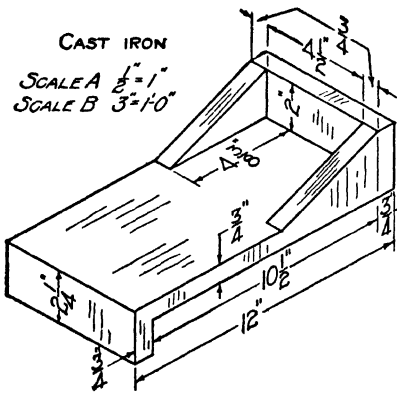

FIG. 11. Truss block.

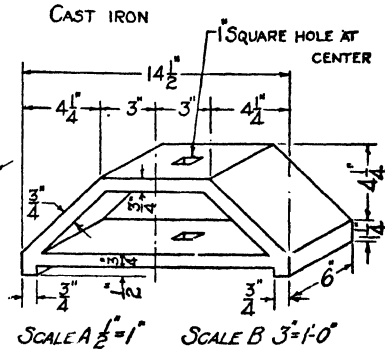

FIG. 12. King post truss block.

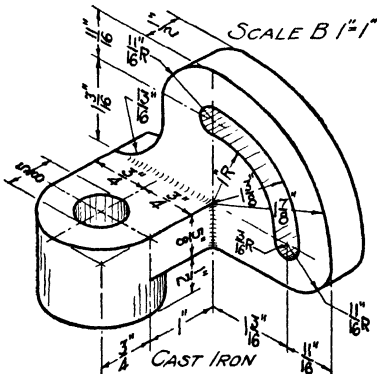

FIG. 13. Swivel bracket.

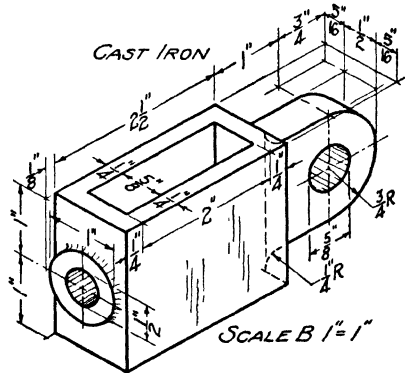
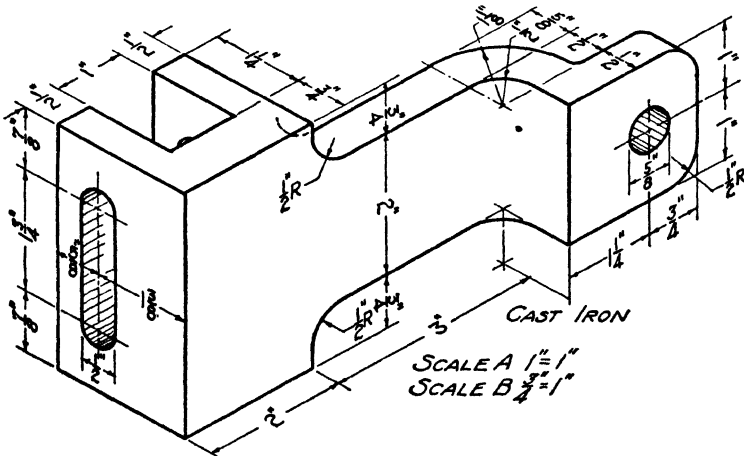

FIG. 14. Sliding bracket.



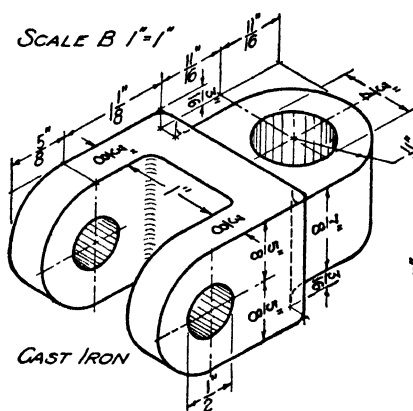

FIG. 16. Link.

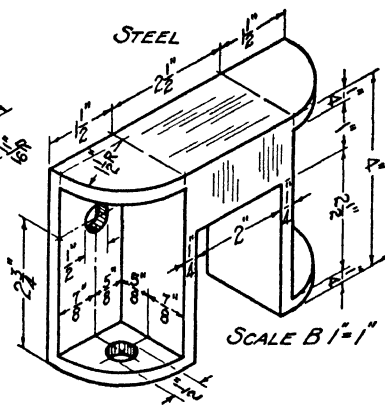

FIG. 17. Bracket.

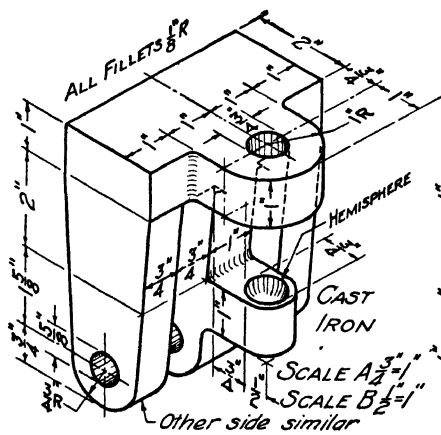

FIG. 18. Caster.

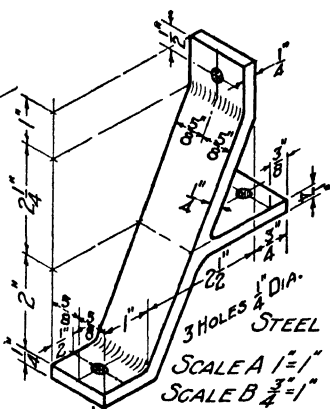

FIG. 19. Brace.

UNIT XII

WORKING DRAWINGS. CONSTRUCTION DIMENSIONING

PURPOSE OF UNIT XII

The purpose of Unit XII is to show how to select and properly indicate on a drawing the dimensions which are necessary for construction or manufacturing.

WHAT YOU SHOULD KNOW ABOUT DIMENSIONING

In the preceding unit we studied the principles which govern the skilful making and proper placing of dimensions upon the drawing sheet, but no attention was given to the second factor, which is still more important, namely, what dimensions shall be put upon a drawing. In this unit, therefore, we shall consider what dimensions to put on a drawing and how to represent them for the convenience of the workman. A first general rule to be stated is that the workman must not be required to make any numerical computation whatsoever in laying out the work.

It is helpful to divide the consideration of construction dimensioning into two parts. These two divisions are: (1) size dimensioning and (2) location dimensioning. That is to say, we must give (1) the size of every part of an object and (2) its location relative to all other parts of the object. For example, in a house plan, the workman must know first the size of a window, and second, just where it is to be located. In machine drawing, the machinist must know first the size of a hole to be drilled, and second, exactly where it is to be located. Although the expert draftsman must have considerable knowledge of shop construction to dimension a drawing successfully, nevertheless with these two principles in mind the beginner may make a common-sense

attack upon any dimensioning problem. The following suggestions will serve as a guide.

Size dimensioning. The simplest thing we can dimension is a straight line. This has length only. To dimension any straight line, the witness lines, *ab* and *cd* in Fig. 1, must extend out at right angles to the line, and the dimension line must be parallel to the original line and begin and end in arrows on the witness lines. To attempt to show the dimension in any other manner is incorrect. Several incorrect schemes are shown in Fig. 1, and common sense will indicate at a glance that the length of the line is not that of the dimension lines.

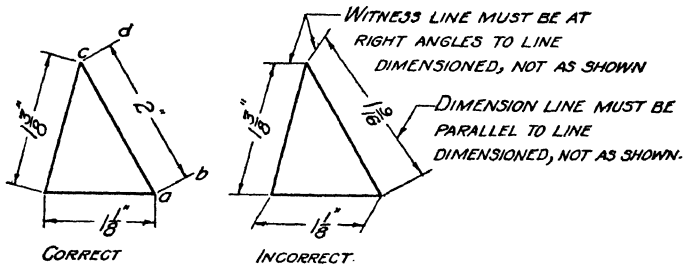

FIG. 1. Placing of dimension lines.

A line which is to be dimensioned must show in the drawing in its true length, that is, it must be parallel to the plane of projection. Thus the 2-inch dimension between the top and front views of Fig. 2 gives the length of the sides *EF* and *HG*, and the $\frac{5}{8}$ -inch dimension gives the length of the lines *AB* and *CD*. The $\frac{3}{8}$ -inch dimension, however, does not represent the length of any line in the object, but it does represent the horizontal distance from the line *FG* to the line *BC* measured in the plane of the top, which is exactly the way a workman would proceed to make his measurements if he were constructing the object out of a solid block; it is therefore a necessary dimension. In the same way the dimensions 1 inch, $\frac{1}{2}$ inch and $1\frac{1}{4}$ inches do not represent the dimensions of a single line on the object, but they do give dimensions which are necessary for the construction of it.

The lines *EA*, *BF*, *CG* and *HD* cannot be dimensioned in either view, since they are not parallel to either plane of projection, and hence do not show in true length. The dimensions of these lines are entirely unnecessary in constructing the object, hence views showing their true lengths are not needed.

Figure 2 illustrates the proper form for arranging a series of dimensions. An over-all dimension should always accompany a series of dimensions, for two reasons: first, so that

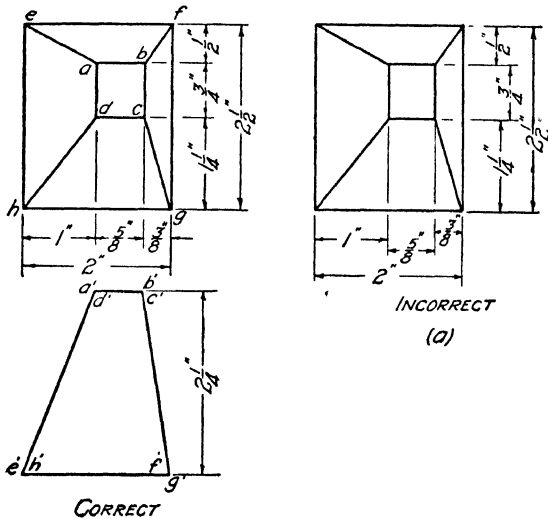

FIG. 2. Correct and incorrect dimensioning.

the accuracy of all dimensions in the series may be checked; and second, so that the workman will not have to add the detail dimensions to obtain the over-all size with which he must begin. Notice that the detail dimensions should be kept in line with each other and not as in *a*, Fig. 2.

Dimensions should not be repeated on different views. Such repetition requires time and serves no useful purpose, and in the case of changes in design it makes the possibility of error much greater, since the draftsman may change the dimension in one place and forget to change it in another.

So far as possible, only visible outlines should be dimen-

sioned. Thus, if a part of an object is visible in one view but invisible in another the visible view should be dimensioned. Sometimes a part is not visible in any view, and then, of course, this rule cannot be applied.

Occasionally the spaces in which dimensions should be placed are very small so that it would be difficult or impossible to place the dimensions between the witness lines. Figure 3 shows several methods of arranging such dimensions.

Circles should be dimensioned in the view in which they show as circles rather than in the view where they show as straight lines. Where this is impossible, the circle may be

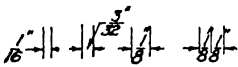

FIG. 3. Dimensioning narrow spaces.

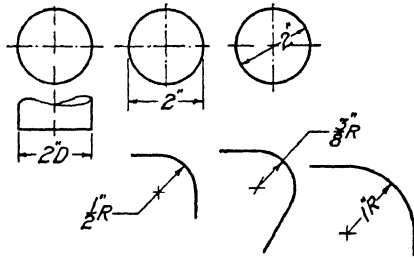

FIG. 4. Dimensioning arcs and circles.

dimensioned on the straight-line view, but the letter *D* (Diameter) should be added to the numerals as shown in Fig. 4.

Circles should always be dimensioned by diameters, since this is the measurement the workman will use in construction. He will measure a cylinder or a large hole with calipers, which must be set to the diameter. If a hole is to be drilled, he will select the drill bit by its diameter. Figure 5 has several illustrations of this point.

Arcs of circles, on the other hand, such as rounded corners, etc., should be dimensioned by radii, for the reason, as stated before, that the workman will use the radius in laying out his work. Figure 4 represents correct methods of dimensioning both circles and arcs.

Location dimensioning. In addition to giving the size of the whole object and of its various parts, it is also necessary to locate these parts, such as holes, bosses, pins, etc., with reference to the center lines or faces of the object. Since such dimensions give the location of some part of the object they may be distinguished by the name, *location dimensions*. Every part of an object requiring definite location must be located in two directions in one view. If, for example, a hole in an object is on a center line of the object, this locates

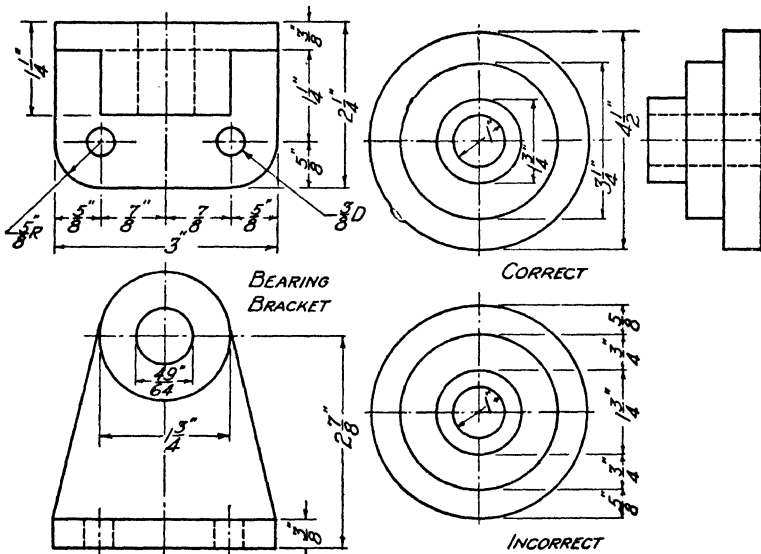

FIG. 5. Examples of dimensioning.

it in one direction; but its distance from another center line, or face of the object, at right angles to the first, must also be given. The hole in the front view of the Timing Shaft Bracket, Fig. 5, illustrates this principle.

If the holes are not on center lines they should be located in two directions at right angles to each other, from either the center lines or faces of the object, if there are no center lines. The two holes in the top view of Fig. 5 illustrate this principle.

Sometimes holes in an object are arranged in circular form,

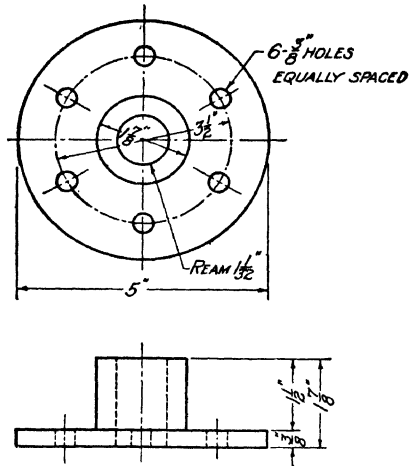

FIG. 6. Dimensioning holes arranged in a circle.

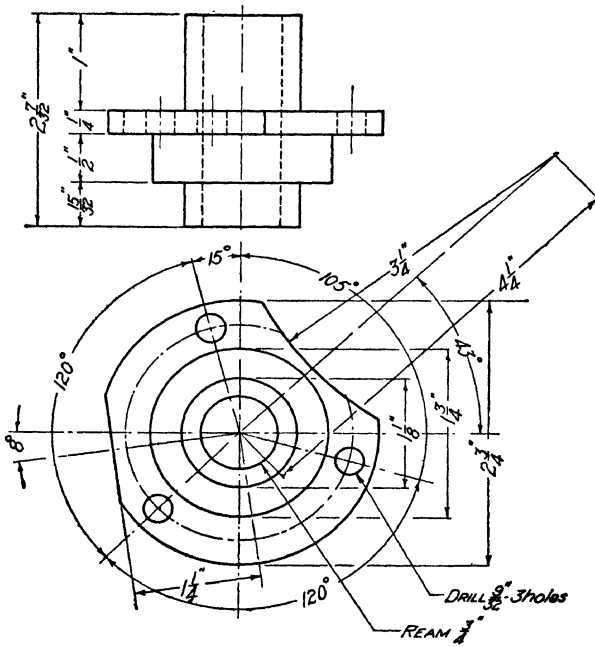

FIG. 7. Dimensioning circular objects.

as in the top view of the face plate, Fig. 6. These holes may be located in two directions, first, by giving the radius of the circle on which they lie, and second, by indicating their spacing in a note, as, for example, "six holes equally spaced," or by indicating their distance from a center line in degrees. The latter method is used when the holes or other parts are irregularly spaced. See Fig. 7 of camshaft front bearing. Holes must always be located by their center lines.

HOW TO SELECT THE PROPER DIMENSIONS TO GIVE ON A DRAWING

First make the proper number of views of the object. Second, study the views as though you were the workman and see what dimensions you would need to make the object. Third, plan the location of these dimensions for convenience in use, bearing in mind the rules learned in Unit XI. You will observe that size and location dimensions cannot always be separated from each other. Thus, in the top view of the bearing bracket in Fig. 5, the $\frac{3}{8}$ -inch dimension gives the size of the supporting web, but this dimension also falls naturally into line with the dimension which locates the hole.

Do not give any dimensions which the workman making the object could not use. Thus, for example, in the top view of Fig. 5 there would be no use for the dimension from the front of the bearing cylinder to the center of the holes in the base, nor from the sides of the bearing cylinder to the center of the holes in the base.

Draw first the witness lines, then the dimension lines, put on the arrow-heads and lastly put in the proper figure.

QUESTIONS

1. Show by a sketch the proper way to dimension a simple straight line.
2. Can a line be dimensioned in a view where it does not show in its true length?
3. If a series of detail dimensions occur upon one side of an object accompanied by an over-all dimension, show by a sketch how these dimensions should be arranged.

4. What reasons, if any, are there for showing the over-all dimension in addition to a series of detail dimensions?
5. What reasons, if any, are there for not repeating a dimension on two or more views?
6. If a choice is possible, which should be dimensioned, the visible or invisible view of a part of an object?
7. Show by a sketch how spaces which are very narrow, as for example a $\frac{1}{16}$ -inch space, may be dimensioned.
8. Is it proper to place dimensions along center lines? Why?
9. Show by a sketch how a circle should be dimensioned.
10. If it is impossible to dimension a circle in the view which shows as a circle, indicate by a sketch how the straight-line projection of it may be dimensioned.
11. Show by a sketch the proper way to dimension three or more concentric circles.
12. Show by a sketch several correct ways of dimensioning circular arcs.
13. What is meant by a location dimension? Illustrate by a sketch.
14. In how many directions must a hole in an object be dimensioned?
15. If holes are arranged in circular form in an object, show by a sketch how they should be dimensioned.
16. What two things must be kept in mind in selecting the dimension to be placed upon the drawing?

PROBLEMS

Make a dimensioned drawing of an object assigned from the following group.

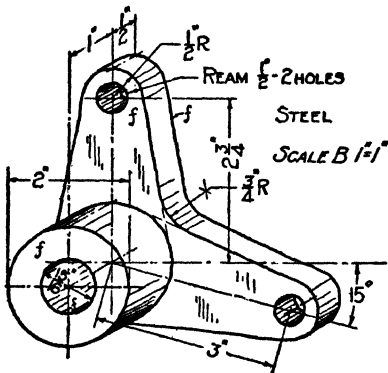

FIG. 8. Rocker arm.

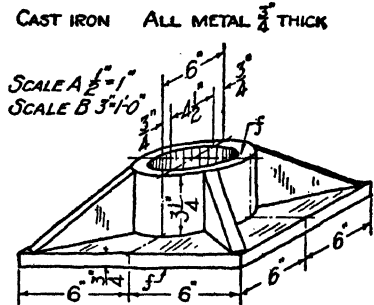

FIG. 9. Column base.

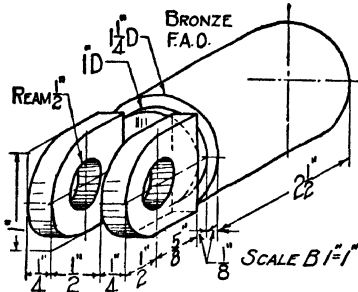

FIG. 10. Pump plunger.

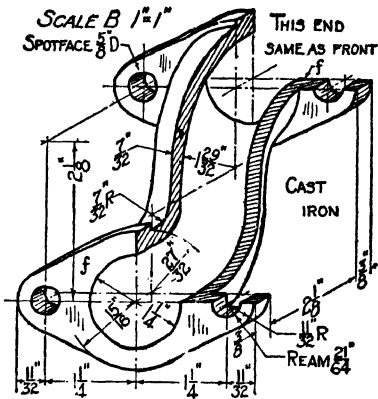

FIG. 11. Manifold elbow.

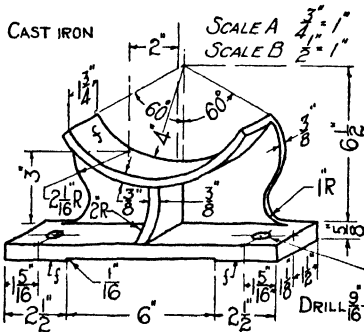

FIG. 12. Conveyor box saddle.

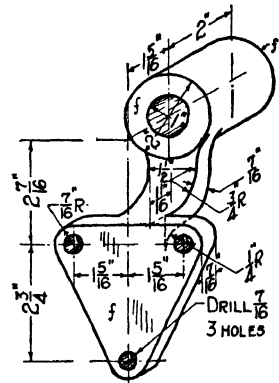

FIG. 13. Bearing bracket.

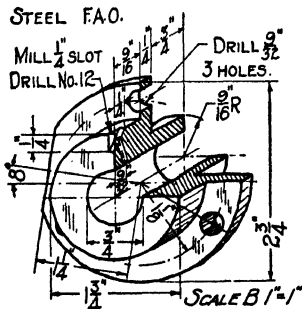

FIG. 14. Camshaft bearing.

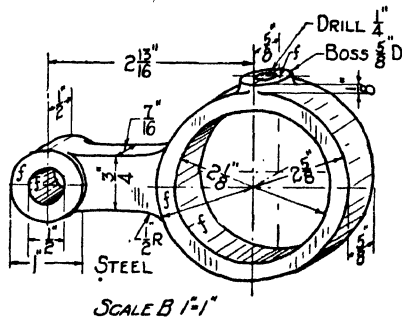

FIG. 15. Pump eccentric.

UNIT XIII

WORKING DRAWINGS. CONSTRUCTION NOTES

PURPOSE OF UNIT XIII

The purpose of this unit is to show what notes should be placed on a drawing so that the workman can construct the object shown without any further directions.

WHAT YOU SHOULD KNOW ABOUT NOTES

After a drawing has been completely dimensioned it is still not a working drawing, for although the workman knows the exact shape and size, many other things must be known before actual construction or manufacture can begin. Such information cannot be shown by projections and must therefore be given in the form of notes. These notes usually deal with three kinds of information, which are discussed in the following paragraphs.

Material. Before anything can be done toward fabrication the workman must know the kind and quality of material to be used. If the object is to be made of steel, the kind of steel must be specified. If wood is to be the material used, the draftsman must specify the kind, such as oak or maple, and the quality, such as clear, select, etc.

In the case of metals, the heat treatment, if any is to be given, such as tempering, case-hardening, annealing, must be noted on the drawing.

Finish. The second general item is the finish to be given the article. If casting is to be left rough, as it comes from the foundry, no marks are necessary. If, however, certain parts are to be machined, these faces are marked in the view where they show edgewise by placing across them the letter *f* as indicated in Fig. 1. If the object is to be finished

all over, such a statement is made as a note, or the standard abbreviation "F. A. O." may be used. See Fig. 2.

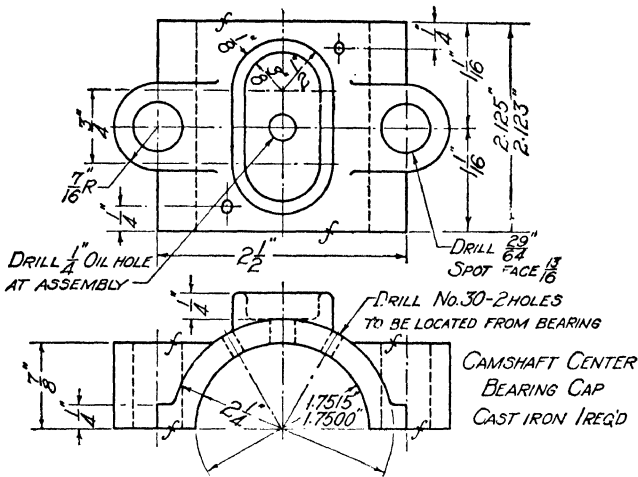

FIG. 1. A working drawing or shop drawing.

For wood, the filler and kind of stain and color may be indicated, whether varnish or shellac or wax is to be used. For cut stone work, the kind of tooling is noted.

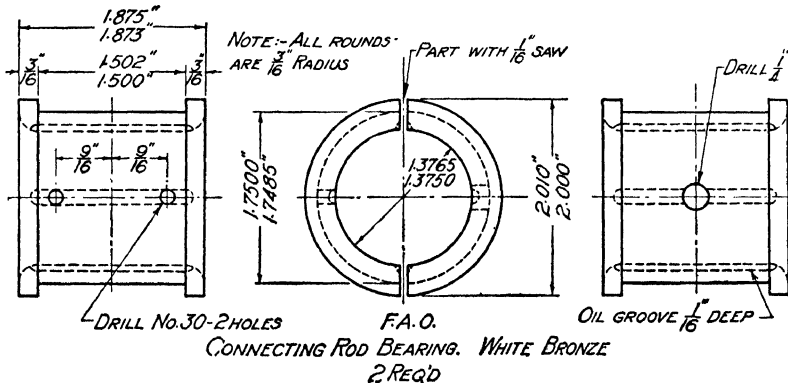

FIG. 2. Dimensioning and noting a working drawing.

Construction methods. The third general group of notes refer to workmanship and methods of manufacture, fabrication and construction. Thus a hole in a casting may be cored and left in the rough, or it may be cored and then

reamed to a finished size. A hole may also be simply drilled through the solid metal. The milling of slots, key ways, and the like, is also indicated by notes. Figures 1 and 2 illustrate the use of a few terms governing the method of fabrication. In this group would fall such specifications as the size and kind of threads to be made on a rod or in a hole,



FIG. 3. Twist drills.*

the number of a gear cutter or hob to be used in making a gear.

In architectural work these notes become so numerous that they are not placed upon the drawings but are gathered together in typewritten or printed form in what is termed the "Specifications."

The following terms which occur frequently on drawings should be familiar to the draftsman.

Drill. This term refers to the process of making a hole



FIG. 4. Hand reamer.

in metal by revolving a cutting tool called a twist drill under pressure. The machine which operates the tool is called a drill press. The tool is shown in Fig. 3. Drills may be obtained in all sizes from $\frac{1}{8}$ inch to 3 inches in diameter.

Ream. A hole that has been drilled is left with a surface that is slightly rough and is not suitable for close fits. The reamer is used to smooth the hole and bring it to an accurate finished size. The shape of the tool is shown in Fig. 4. The tool is operated in a drill press.

* All half tones in this unit by courtesy of the Pratt & Whitney Co.

Countersink. This term means to enlarge the top of a hole, as shown in Fig. 5, with a revolving tool, as shown in the same figure. This tool is also operated in the drill press. The purpose of this is to bring the head of a screw flush with the top of the metal.

Counterbore. This term means to enlarge the top of a hole, as shown in Fig. 6, to accommodate the head of a screw.

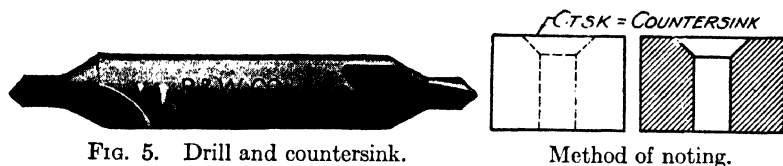

FIG. 5. Drill and countersink.

Method of noting.

This is done by revolving a tool, as shown in the same figure, using a drill press, for holes of drill size. The pilot keeps the counterbore lined up with the original hole. Without this it might work off center. The size of the machine screw to be accommodated must be specified, or the diameter and depth of the counterbore must be given.

Bore. This operation also refers to a method of making a hole. It is done in a lathe or upon a special machine called

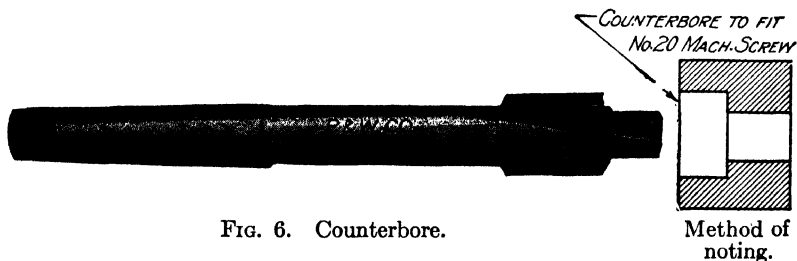

FIG. 6. Counterbore.

Method of noting.

a boring mill. Small holes may be drilled, but those above the largest drill sizes must be bored if they are to have a smooth finish. The diameter and depth of the hole must be specified in the note concerning the boring operation.

Core. Holes of large size or irregular shape are made in a casting by means of a core made of sand which has the same shape as the desired hole. This is placed in a mold, as shown in Fig. 7, causing the molten metal to flow around it, leaving

the required opening in the object. Small holes not requiring great accuracy in size or location can also be cored.

Spot face. When it is desired to finish a small portion of an object, as for example, where a bolt head or nut is to

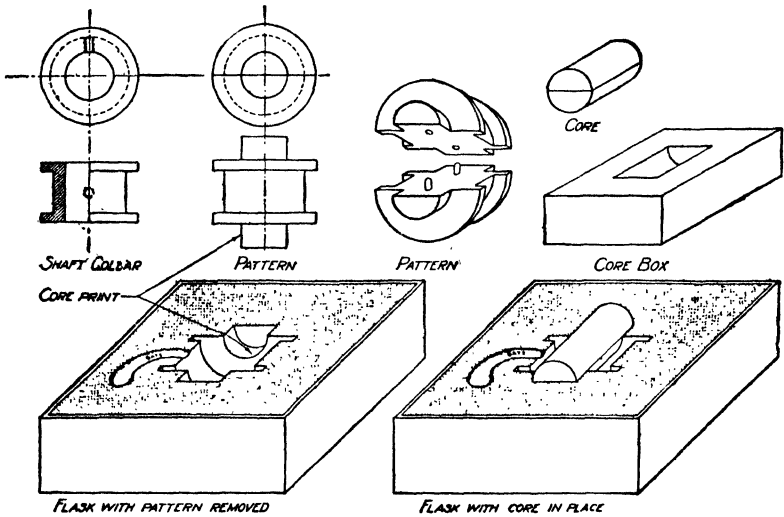

FIG. 7. Pattern, core, core-box and flask.

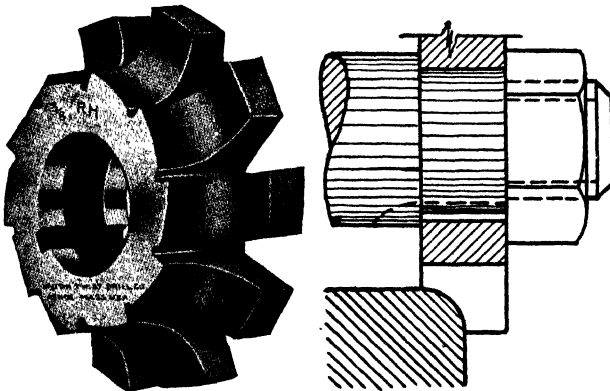

FIG. 8. Milling cutter.

be seated, this can be done without finishing the whole face. The note, to spot face, is then given, and an area large enough to allow the nut to be turned will be finished.

Mill. This term is used to indicate the making of plane

surfaces, rounded corners, slots or grooves on a milling machine. Rotary cutters as shown in Figs. 8 and 9 are used. These cutters may be shaped to make various kinds of

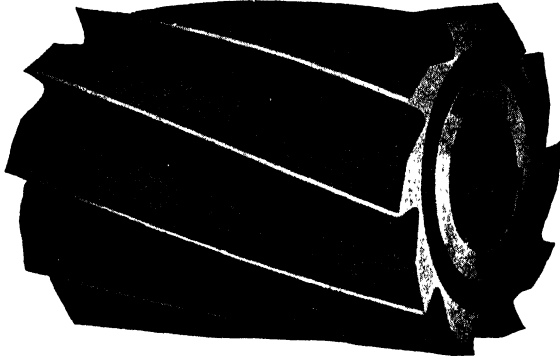

FIG. 9. Milling cutter.

grooves and to perform such operations as the forming of gear teeth.

Tap. When a small hole is to be threaded, the word tap

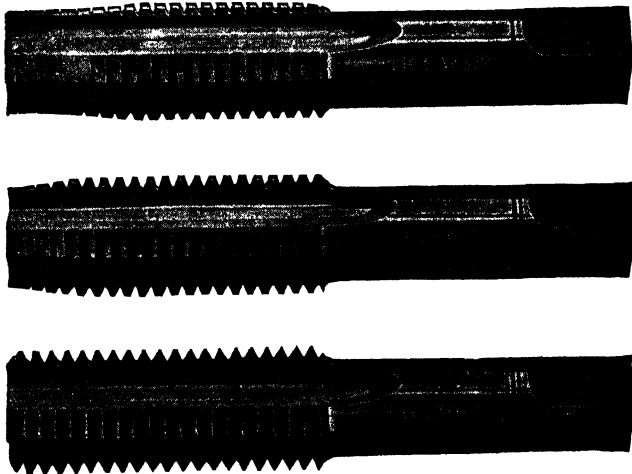

FIG. 10. Taps.

is used on the drawing to indicate this process. The diameter of the thread and the number of threads per inch must follow the word tap to enable the workman to select the

proper tool. The tool used for forming the thread is also called a tap; it is shown in Fig. 10.

Threads are made on rods with tools called dies shown in Fig. 11. No special word is used on the drawing to indicate this operation. The diameter and number of threads per inch are simply indicated in a note.

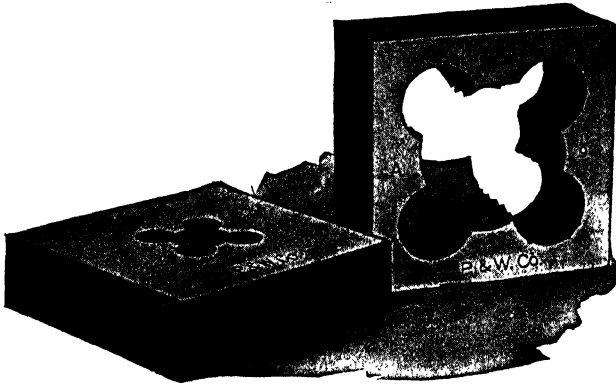

FIG. 11. Dies.

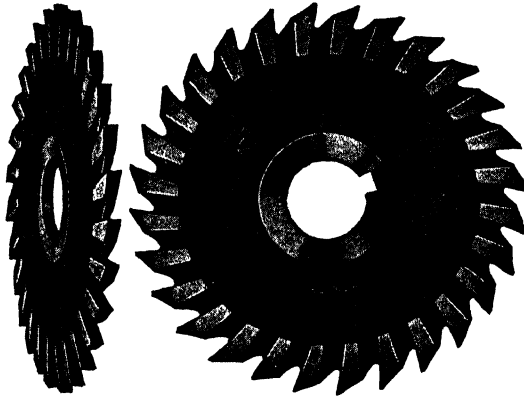

FIG. 12. Slitting saws.

Slit or Part. When a machine part is cast solid and then cut into two parts, or when a slit is cut through one side, the term slit or part is used on the drawing followed by instructions as to the width of slitting saw to be used. Figure 2 illustrates the use of such a note; Fig. 12 shows two types of saws used.

Knurl. A machine part which must be turned between the thumb and fingers is usually roughened to provide a better grip. The process of making the surface rough is called knurling. Such surfaces are represented as shown in Fig. 13, which also shows the tool used in the process.

Specific and general notes. Notes on a drawing may be readily divided into two groups, namely, the specific type which refers to some particular part of the object only, and the general type which refers to the entire object. Notes covering such items as the name of the object, number wanted, material of which it is to be made and painting are of the latter class, since they usually refer to the whole

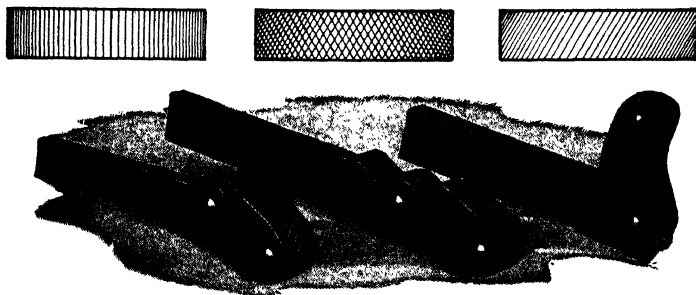

FIG. 13. Knurling tools and knurls.

object; the notes covering methods of construction, threads and finish usually refer to one part only and are therefore quite specific in character.

General notes should be placed in a conspicuous place under the entire group of views in such a position that their general nature is indicated. Their lettering should also be made larger than that of the specific notes, usually about $\frac{5}{32}$ or $\frac{3}{16}$ inch. General notes are not connected to the drawing by leaders.

Specific notes, on the other hand, should be made in letters from $\frac{1}{8}$ to $\frac{5}{32}$ inch high and should be placed near the part to which they apply. They should then be connected to that part by a leader, the arrow-head of which terminates exactly on the part to which the note refers.

Figures 1 and 2 illustrate the placing of both kinds of notes. Notes of whatever kind should always be placed upon the drawing in a horizontal position so that they may be read from the bottom of the sheet.

HOW TO PUT CONSTRUCTION INFORMATION ON A DRAWING

Complete the projections and dimensions first, with the exception of those holes, grooves and slots whose dimensions will be specified in notes. Plan the location of specific notes by finding a clear path for the leader so that it will not have to cross over too many dimension lines and other parts of the drawing. When such a path has been found leading to a clear place on the paper, rule the guide line $\frac{1}{8}$ inch high for the note and letter it in.

Draw the leader with the arrow touching the part to which the note applies, the other end terminating in a horizontal line at the mid-height of the letters at the beginning or end of the note.

Having completed all specific notes, rule the guide line $\frac{5}{32}$ inch high for the general note in a central position below the views to which it applies. This note will include the name of the object, if not given in the title, the material of which it is to be made and the number of pieces required.

QUESTIONS

1. In addition to dimensions, what must be added to an orthographic projection of an object to make it a working drawing?
2. What type of information necessary for construction cannot be shown by projections or dimensions?
3. Show by a sketch how a finished surface is indicated in a drawing.
4. Show by a sketch how a method of fabrication is indicated.
5. Where should specific notes on a drawing be placed?
6. How are specific notes connected to the parts to which they apply? Illustrate.
7. Which should be made in smaller letters, the specific or the general notes?
8. Where should general notes be placed upon the drawing?
9. About what size should the letters in general notes be made?
10. Define the terms tap, bore and countersink.
11. Define the terms core, ream and drill.
12. Define the terms mill, knurl and counterbore.

PROBLEMS

Make a complete working drawing of the objects assigned from the following group. Proceed in the following order:

Draw border lines and title space.

Block out views with rectangles to secure a balanced sheet.

Draw center lines and complete views.

Draw dimension lines and put on arrows.

Put in dimensions.

Plan and put in specific notes.

Put in general notes.

Fill in title, the name of which will be the name of the object.

Submit pencil drawing for approval and correction.

Ink if so directed.

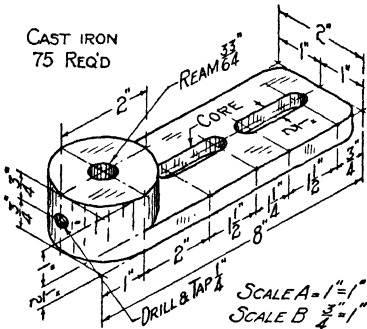

Fig. 14. Chain tightener.

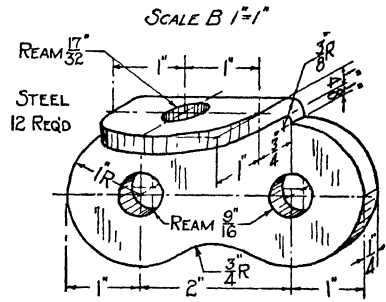

Fig. 15. Chain link.

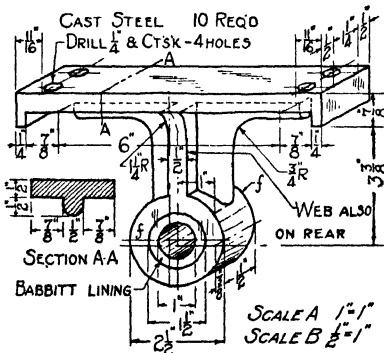

Fig. 16. Shaft hanger.

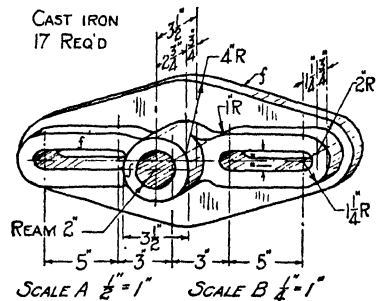

Fig. 17. Chain tightener.

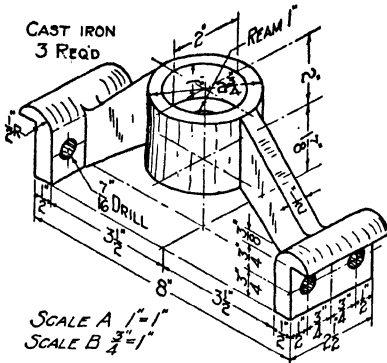

FIG. 18. Conveyor bearing support.

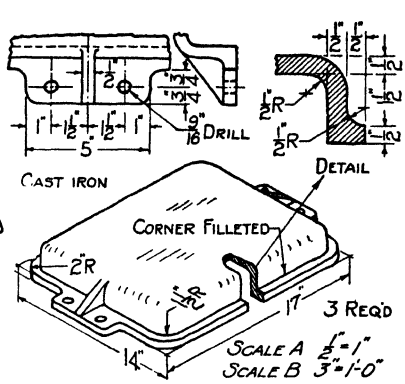

FIG. 19. Gear box cover.

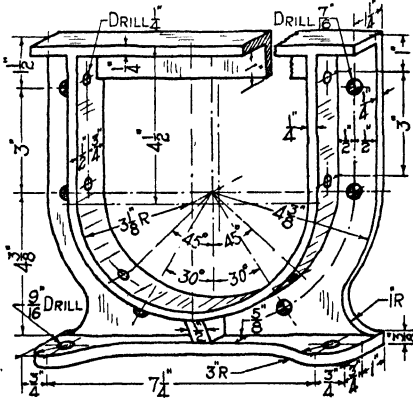

FIG. 20. Conveyor support.

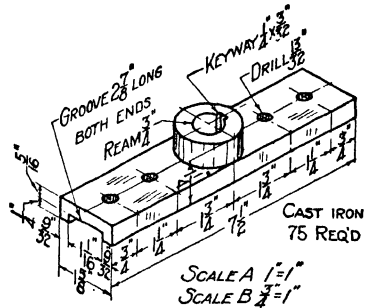

FIG. 21. Double lever end.

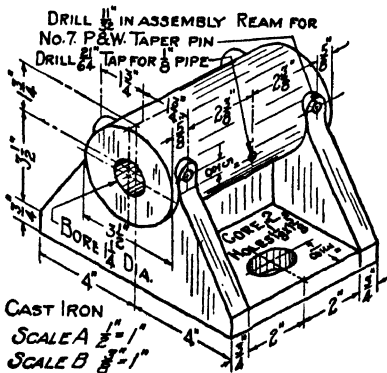

FIG. 22. Horizontal roller bearing.

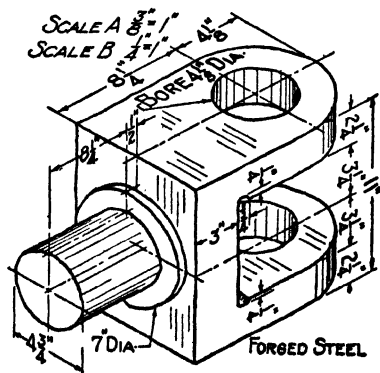

FIG. 23. Buffer yoke.

UNIT XIV

FREEHAND ORTHOGRAPHIC SKETCHING

PURPOSE OF UNIT XIV

The purpose of this unit is to point out the need for free-hand orthographic sketches and to show how to make such sketches.

WHAT YOU SHOULD KNOW ABOUT FREEHAND SKETCHING

The uses of sketches. Almost everyone occasionally needs to draw a freehand sketch of some object which is to be made or repaired, or which he is trying to describe to someone else. Technical men, such as architects, building contractors, engineers in charge of construction projects, shop foremen, etc., frequently have to make use of sketches in directing the men under their authority. The essential purpose of sketching is to express clearly, accurately and rapidly one's ideas about objects and mechanical processes which cannot be expressed effectively in words alone. To sketch clearly, accurately and rapidly requires a knowledge of sound procedures as well as frequent practise.

Importance of close observation of proportions. The first step in learning to be skilful in sketching is to train oneself to observe objects closely and accurately. It is particularly important to notice the main proportions of objects and the shapes and relative sizes of parts. If one desires to sketch a pine table, as shown in Fig. 1, important questions to answer are: How does the length of the top compare with the height of the table? How does the width of the top compare with the height? How do the rails compare in width with the height? How does the thickness of the legs compare with the width of the rail? Here the height is the chief standard of measurement, but any other dimension might

be so used. By picking out some convenient dimension, such as height, width, thickness, etc., and comparing the other dimensions with it, whenever examining any object, one comes to be conscious of proportions and is thereby better able to learn to sketch easily and accurately any object he may wish to describe. Without a sense of relative sizes of parts and chief dimensions it is very difficult to acquire skill in sketching.

Orthographic sketches. Orthographic sketches, or working sketches as they are usually called, are in fact freehand

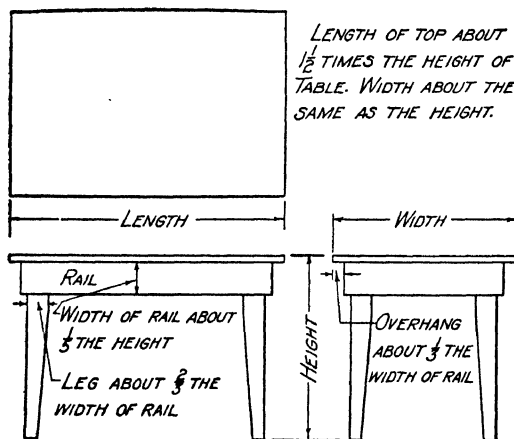

FIG. 1. Judging proportions of table.

working drawings, or orthographic projections. Hence, they must conform to all the principles of good orthographic projections and working drawings as given in Units VII to XIII, inclusive. The views of the object sketched must be chosen and arranged just as in making a working drawing with a T-square and triangles. All needed dimensions must be carefully shown, and all necessary notes must be given. A working sketch should give all necessary information to a draftsman who wishes to make a scale drawing of the object sketched, or to a workman who will make or repair the object.

HOW TO MAKE WORKING SKETCHES

To make a working sketch. First, decide on the number of views needed to express your thought clearly. If, for example, a front view, a top view and a side view are needed, examine carefully the object you have in mind to determine its proportions. If you are sketching from an object which is before you, select some dimension (width, height, thick-

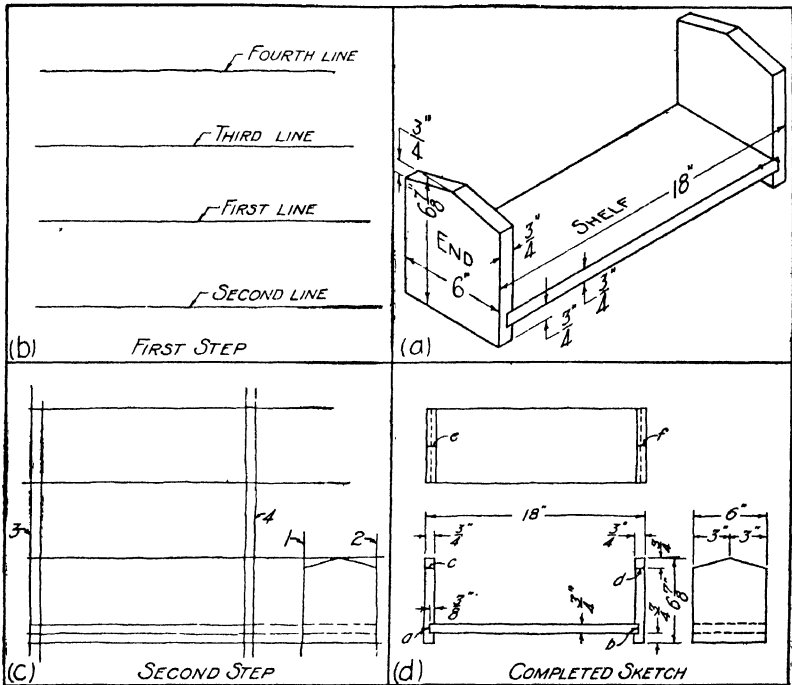

FIG. 2. Steps in sketching.

ness, etc.) as your unit or standard of measurement. If you are working from an imaginary design of which you have only a mental picture, decide on the chief dimensions, as: "the width will be 6 inches, the length 20 inches," etc.

Suppose you are to sketch a small bookrack, as shown in Fig. 2a. It is seen that the ends of the rack are $\frac{3}{4}$ "x6"x $6\frac{1}{4}$ ", and the length is 18". Hence, the length is just three times

the width and the height is slightly greater than the width. Clearly, the width makes a convenient unit for measuring the sketch. A little below the center of your sheet sketch a line across the paper, as shown in Fig. 2b, making it as straight as you can. To do this, hold the pencil lightly in the usual writing position, but about 2 inches from the point. Then, with rapid, short, overlapping strokes, each about $\frac{1}{2}$ inch long, make the line. If it is not straight, erase any irregularity and try again. Then go over your line lightly, smoothing out the rough places made by the short overlapping strokes. This will be the top line of the front and end views.

Next draw a line parallel to the first one and below it at what you estimate to be a suitable distance to represent $6\frac{7}{8}$ inches in a sketch of the size you wish to make. Then, above the first line drawn, sketch two other horizontal lines at a distance from each other representing 6 inches. These lines will be the front and back edges of the top view. Your drawing will now be as shown in Fig. 2b.

Now sketch a horizontal line above the bottom line of the front view at a distance from it which would represent $1\frac{1}{2}$ inches. You can make a good guess at this distance by considering that $1\frac{1}{2}$ inches is a little less than one-fourth the height of the rack. Try to estimate where one-fourth the height is, and sketch your line slightly below that point. Then halfway between the bottom line and the one you have just sketched, draw another horizontal line. These two lines give you the front view of the shelf. Next, holding the pencil as before, sketch lines 1 and 2 vertically in the lower right-hand corner to make a rectangle which is a little higher than it is wide, using short, light, overlapping strokes. This blocks in the end view. In the same manner, sketch vertical lines 3 and 4 a distance apart equal to three times the width of the rectangle, which will represent the length of the rack. Then sketch the other two vertical lines forming the ends, a distance apart equal to the distance between the lower

two horizontal lines. Next sketch the slant lines of the end view from the center of the top edge to points on the side edges representing $\frac{3}{4}$ inch from the top. Your sketch will now be as shown in Fig. 2c. Finish your views by sketching the lines *a* and *b*, *c* and *d*, *e* and *f*, and the invisible lines of the shelf in the end view as shown in Fig. 2d. Finally sketch in dimension lines, and make arrow points and figures; then erase all lines not needed. The complete sketch will be as shown in Fig. 2d.

To sketch curved lines. To sketch a circle, first sketch the vertical and horizontal diameters, then with short, light, overlapping strokes sketch the circle through the ends of

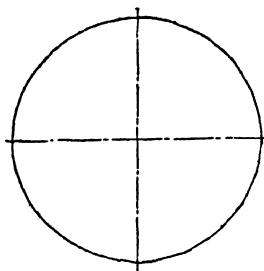

FIG. 3. Sketching a circle.

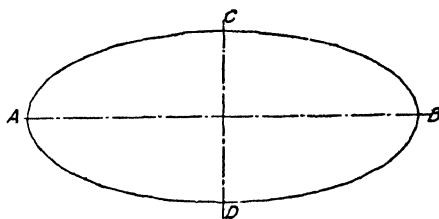

FIG. 4. Sketching an ellipse.

these diameters, as illustrated in Fig. 3. Start at the top, and make first the left half of the circle; then begin again at the top and make the right half. Finally, go over the lines, smoothing out irregularities.

An ellipse is an elongated, regular curved figure as shown in Fig. 4. The vertical line *CD* and the horizontal line *AB* passing through the center of the ellipse are called the axes. To sketch an ellipse, first draw the axes, then proceed exactly as with the circle. Start at *C* and sketch the left half *CAD*, then start again at *C* and sketch *CBD*.

To sketch an irregular curve, first sketch an imaginary tangent quadrilateral, then estimate the location of the points of tangency and sketch the curve through them. See Fig. 5.

To sketch an arc or other open curve, first draw a tangent angle and estimate the location of the points of tangency, then sketch the curve through these points. See Fig. 6.



FIG. 5. Sketching an irregular curve.

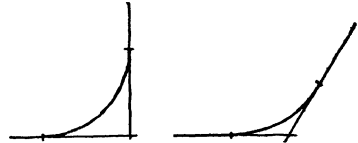

FIG. 6. Sketching an arc.

QUESTIONS

1. How should the pencil be held in sketching?
2. Why is it best to use short, overlapping strokes when sketching? How would you sketch a vertical line? A horizontal line?
3. Why is it desirable to use tangent angles or tangent quadrilaterals when sketching open and irregular curves?
4. How would you dimension the curve shown in Fig. 5?
5. What is the purpose of making freehand sketches?
6. Who has frequent occasion to make freehand sketches?

PROBLEMS

Lay out the standard border line and title space and do the problems assigned from the following list.

1. Divide the standard sheet into four equal rectangles.
 - (a) In the first rectangle, sketch sixty-four equal rectangles. To do this, divide both the top and left sides of the rectangle into eight equal parts and sketch horizontal lines through the points of division on the left side line and vertical lines through the points on the top line. To locate the points of division on the top and side borders of the rectangle respectively, first estimate the center of the line and place a point there; then place a point at the center of each half of the line, then at each quarter of the line. This will divide the line into eight equal parts.
 - (b) In the second rectangle, divide all sides into four equal parts. Sketch both diagonals of the rectangle, and through each division point of the four sides sketch lines parallel to both diagonals.
 - (c) In the third and fourth rectangles sketch the two center lines connecting the mid-points of sides. Using these center lines as axes, sketch an ellipse in each rectangle, making the longer axis almost as long as the rectangle and

the shorter axis about one-half the long one. Using the short axes of the ellipses as diameters, sketch also a circle in each rectangle. The circle is to be inside the ellipse and have the same center lines.

2. Make a working sketch of an object assigned from the following group.

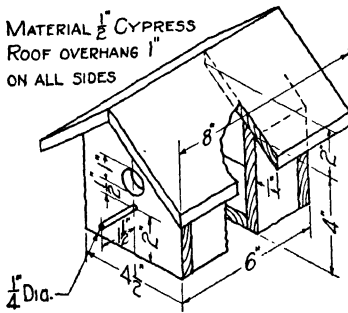

FIG. 7. Wren house.

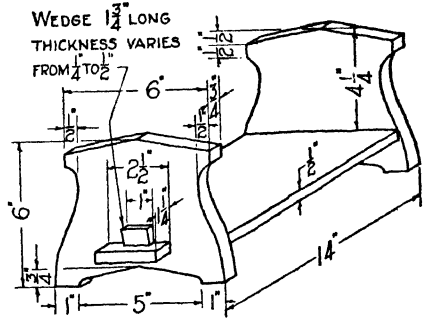

FIG. 8. Book rack.

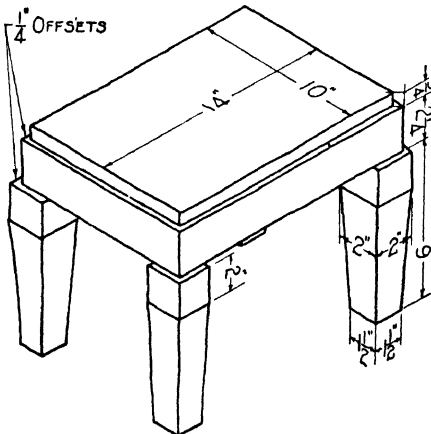

FIG. 9. Foot stool.

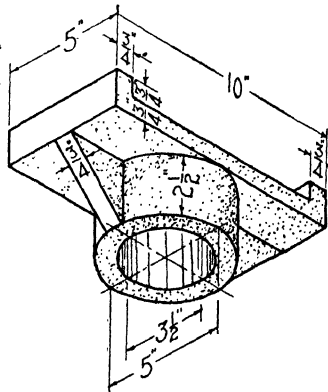

FIG. 10. Post cap.

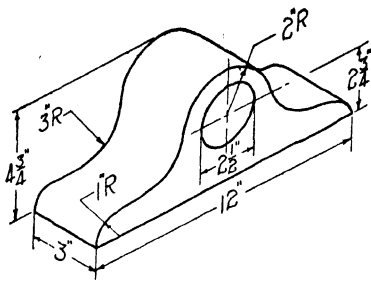

FIG. 11. Clock case.

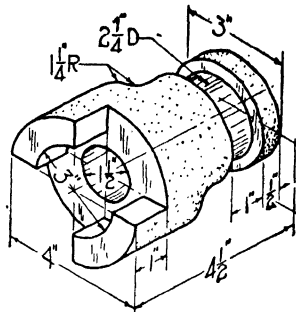

FIG. 12. Jaw clutch.

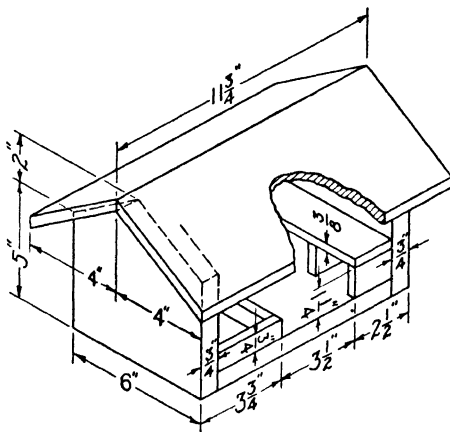

FIG. 13. Bird feeder.

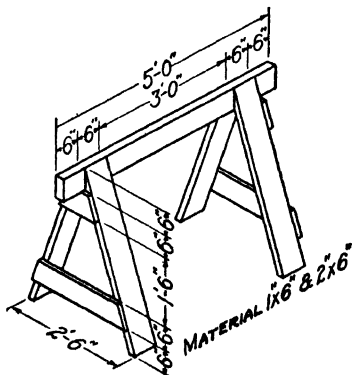

FIG. 14. Carpenters horse.

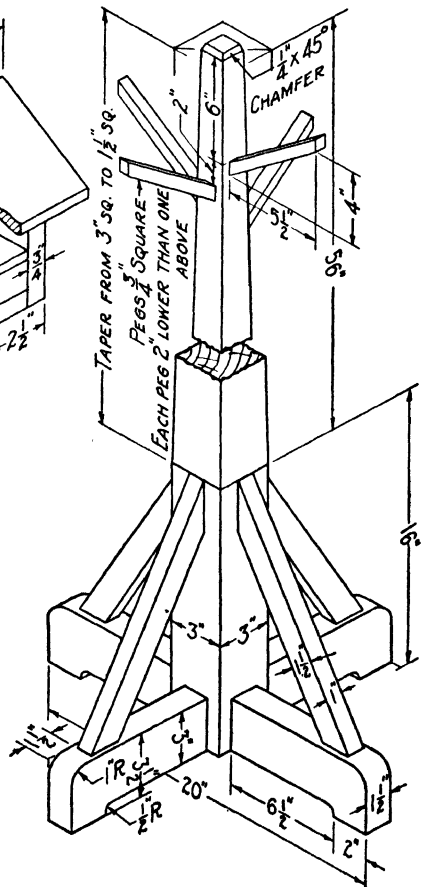

FIG. 15. Costumer.

UNIT XV

FREEHAND PICTORIAL SKETCHING

PURPOSE OF UNIT XV

The purpose of this unit is to teach the use of pictorial sketching and to show how to make isometric sketches.

WHAT YOU SHOULD KNOW ABOUT PICTORIAL SKETCHING

It is often desirable to sketch an object pictorially, that is, as it appears when one looks at it. A pictorial sketch is a picture and shows an object not as it really is but rather as it appears to the eye. One never sees anything as it really is, because the parts nearer the eye of the observer appear larger than the parts farther away. Also parallel edges of an object appear to the eye to run toward each other as they recede from the observer. Hence an accurate pictorial-drawing, or *perspective* drawing, as it is called, does not show parts in their true dimensions. For this reason, an approximate perspective sketch which does show parts in their true dimensions is more useful to those engaged in mechanical work. There are several methods of sketching approximate perspective representations, but for mechanical work the isometric sketch is usually the most satisfactory. The word *iso-metric* means equal measure. This name is used because in isometric drawings parts of an object which are actually equal in size are drawn equal, no matter how near or how far they may be from the eye of the observer. The chief value of the isometric sketch, aside from the ease with which it can be made, is that it not only gives a very satisfactory picture of an object but it also shows every part in its true proportions. In Fig. 1, the block of wood is shown at *M* in a perspective sketch. Notice how much shorter *AD* and *FG* are than *BC*, and *EF* than *AB*. Yet on the

block itself the edges AD , BC and FG are all the same length, as are AB and EF . To make the sketch show exactly as the block appears to the eye it is necessary to make the edges farther from the eye of the observer shorter than those near the eye of the observer. But notice that in the isometric

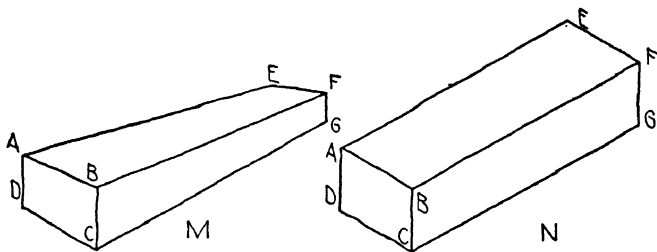

FIG. 1. Perspective and isometric compared.

sketch, at N , of the same block, a fairly clear idea of the appearance of the block is given and at the same time equal edges are actually drawn equal.

In isometric sketching all vertical edges are shown as vertical lines, and all horizontal edges of surfaces which make right angles with each other are shown as lines run-

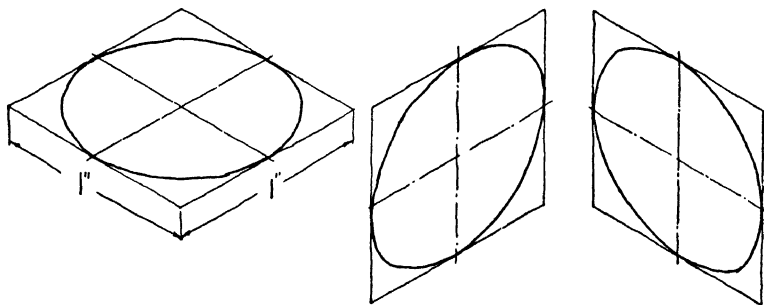

FIG. 2. Circles in isometric.

ning to the right and left respectively at 30 degrees to the horizontal. Curves are sketched by first sketching a rectilinear figure enclosing the curve. For example, a circle is shown by first making an isometric sketch of an imaginary square in which the circle is inscribed, then sketching the

isometric circle through the points of tangency. A 1-inch circle would be sketched inside an isometric square of 1 inch, as in Fig. 2. Slant lines are made by locating points on the rectangles they touch and connecting the points, as, for example, AB in Fig. 3.

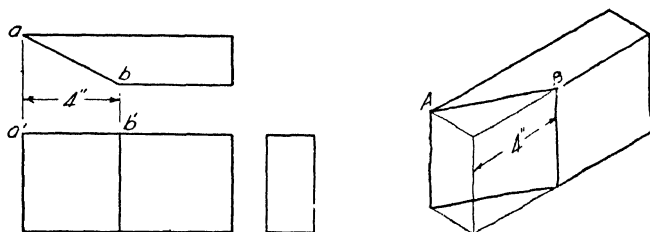

FIG. 3. Slanting or non-isometric lines.

HOW TO MAKE ISOMETRIC SKETCHES

To make isometric sketches. Before you attempt to make an isometric sketch, practise sketching the three isometric axes, ox , oy and oz , as shown in Fig. 4, with T-square and 30 degree triangle; then sketch these three axes freehand until you have a "feeling" of 30 degrees with the horizontal.

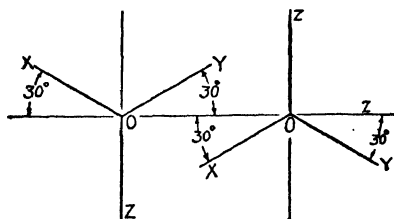

FIG. 4. Isometric axes.

Next, examine closely the object you wish to sketch and estimate its main dimensions, if you do not know them. If, for example, you are sketching a small, square telephone table, estimate its height and sketch a vertical line representing the edge of an imaginary block or box which would exactly enclose the table, as line AE in Fig. 5. Then from points A and E , respectively, sketch lines to the right and

to the left running at 30 degrees to the horizontal. Then, on these lines, point off *B*, *D*, *F* and *H* at distances which represent the length and width of the top of the table. From *D* and *B* sketch 30-degree lines intersecting as at *C*. Sketch similar lines from *F* and *H*, and then complete the block by sketching the vertical lines *DH* and *BF*. From the points *H*, *E* and *F*, measure back a distance representing your estimate of the overhang of the top. Then connect with 30-

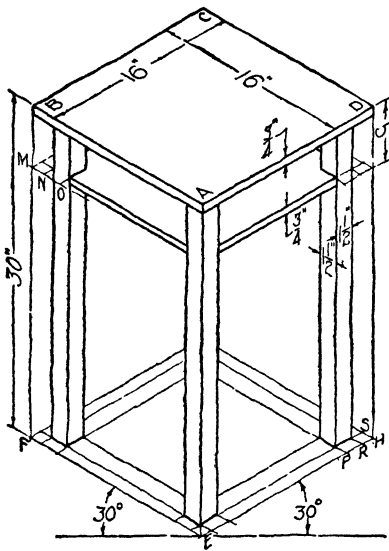

FIG. 5. Blocking out a table.

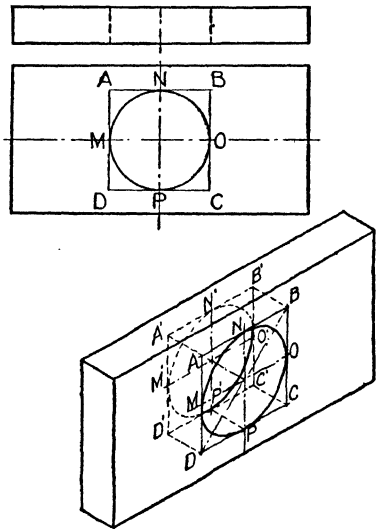

FIG. 6. Blocking out a cylindrical hole.

degree lines the points thus found, as *P*, *R*, *S*, to locate the bottoms of the legs. Then sketch vertical lines forming the edges of the legs. In similar manner the shelf is sketched, as shown in Fig. 5, and the table top is completed. Next mark all needed dimensions, using dimension lines with arrow points, then erase all lines which are not edges of the table.

To sketch isometric curves. When curves occur in an object to be sketched, first sketch an orthographic view of the curve which gives its true shape, and sketch about it

a tangent rectangular figure. Then locate the tangent points on the rectangular figure. Next make an isometric sketch of the rectangular figure and mark the tangent points at their exact location as indicated in the orthographic sketch. Then sketch a curve through the tangent points so located. See Fig. 6. If the curve is so irregular that it will touch an enclosing rectangle at too few points to make its reproduction possible by sketching through those points, locate a number of lines perpendicular to the sides of the rectangle and ending in the curve. These lines can easily be reproduced on the isometric sketch and the desired curve sketched through their ends. For example, suppose you wish to make an isometric sketch of a board with a curved edge, as shown

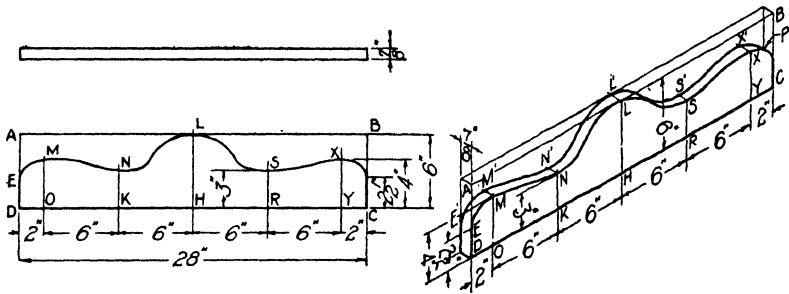

FIG. 7. Coordinates for irregular curve. FIG. 8. Irregular curve in isometric.

in the orthographic views in Fig. 7. First, sketch lines forming the enclosing rectangle *ABCD*. Then at intervals locate lines perpendicular to *DC* which end in the curved edge. Be sure lines occur at the highest and lowest points of the curves, as at *M*, *N*, *L*, *S* and *X*. Then make an isometric sketch of the rectangular board as it was before the curve was cut, as in Fig. 8, and reproduce the vertical lines *OM*, *KN*, *HL*, *RS* and *YX*. Now sketch a curve through the points *E*, *M*, *N*, *L*, etc. Locate points *E'*, *M'*, *N'*, *L'*, etc., which are $\frac{1}{8}$ inch to the left on lines at 30 degrees to the horizontal, and sketch a parallel curve. Where the curve *M'N'L'S'X'* drops behind the curve *MNLSX*, as at *P*, sketch a line tangent to the two curves. The need of this

tangent is also shown in Fig. 9. Erase all lines not representing parts of the object.

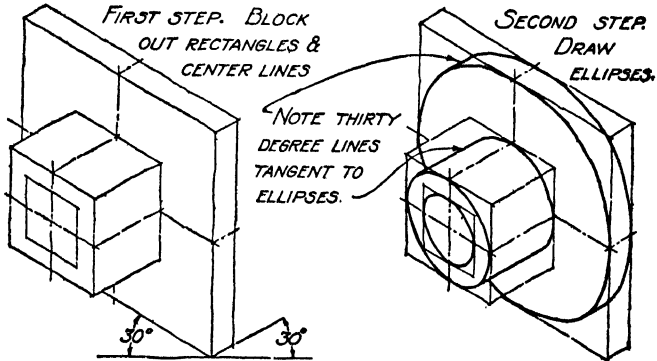

FIG. 9. Sketching a cylindrical object.

QUESTIONS

1. How does a pictorial sketch differ from an orthographic sketch?
2. How does a perspective sketch differ from an isometric sketch? What does the word isometric mean?
3. What is the method of making isometric sketches of irregular curves?
4. How are slanting edges located on an isometric sketch?
5. What are isometric axes? What is the angle between the isometric axes?

PROBLEMS

Lay out the standard border line and title space. Do the problems assigned from the list below.

1. Divide the sheet by a vertical line into two equal rectangles.
 - (a) In the left-hand rectangle make an isometric sketch of a block of wood 1"x4"x4". In the center of one-half of the block sketch a square hole 1" square cut through the block. In the center of the other half of the block sketch a round hole 1" in diameter.
 - (b) In the other rectangle make an isometric sketch of a pyramid having a square base 2"x2" and an altitude of 2½".
2. Make an isometric sketch of an object assigned from the following group.

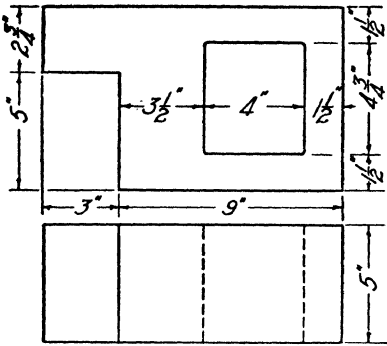

FIG. 10. Concrete tile.

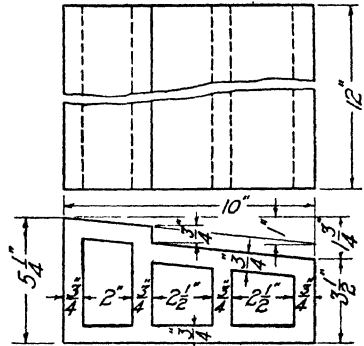

FIG. 11. Hollow clay tile.

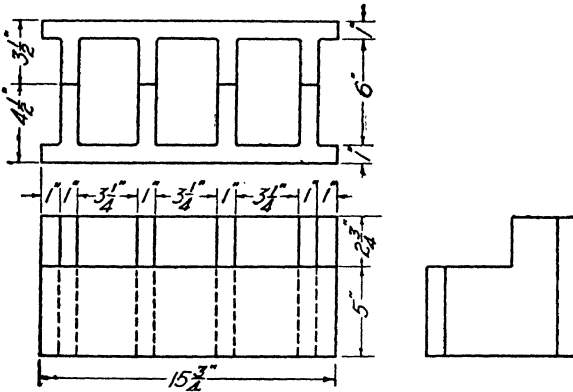

FIG. 12. Concrete header block.

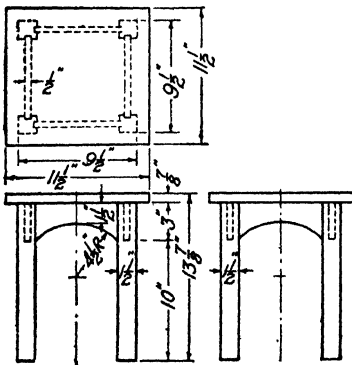

FIG. 13. Taboret.

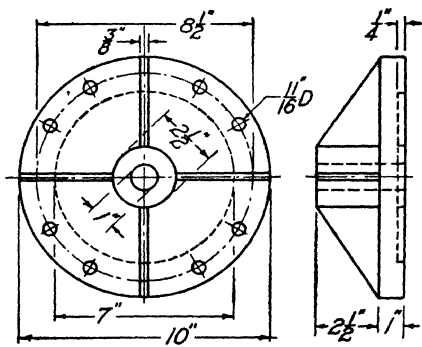

FIG. 14. Cylinder head.

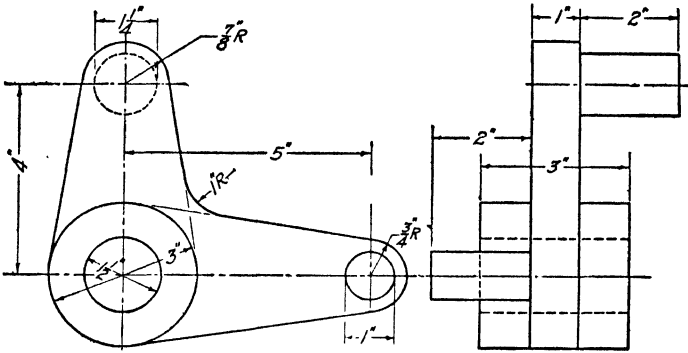

FIG. 15. Rocker arm.

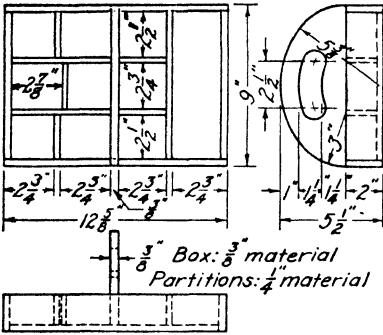

FIG. 16. Nail box.

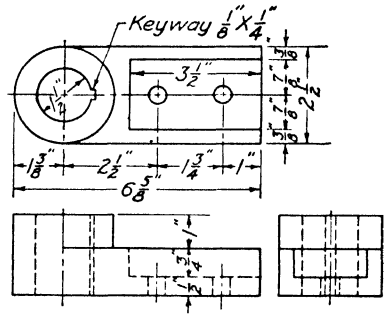

FIG. 17. Lever end.

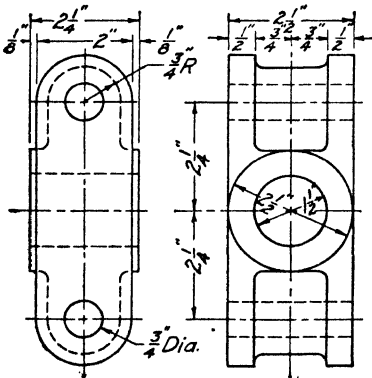
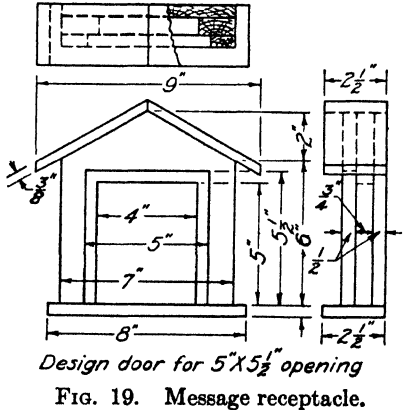

FIG. 18. Cross-head body.



Design door for 5" X 5 1/2" opening
FIG. 19. Message receptacle.

UNIT XVI

TRACING

PURPOSE OF UNIT XVI

The objective of this unit is to show the purpose of tracings and how to make them upon paper or cloth.

WHAT YOU SHOULD KNOW ABOUT TRACING AND TRACING CLOTH

Why tracings are needed. The purpose of commercial working drawings is to give the necessary information for the construction or manufacture of an object. For this reason, many copies of a drawing may be required. One copy, the original, must always be kept on file for reference in the office; then each shop department which works on the object must have a copy, and frequently copies must be sent out to customers and to other manufacturers or contractors. It is very convenient, therefore, to have some method of reproducing drawings economically.

This can be accomplished by blueprinting, a process whereby any number of copies of a drawing can be made very rapidly and at small cost. This process will be described in the next unit.

As a preliminary, however, to utilizing the blueprint process it is necessary to have a tracing of the drawing. As the name implies, a tracing is a copy made with either pencil or ink upon a translucent paper or cloth called tracing paper or tracing cloth.

Tracing paper and tracing cloth can be purchased in sheets or in rolls, 10, 25 and 50 yards in length. Both can also be secured in several different grades. The papers vary widely in degree of transparency, toughness and durability. The best papers are made from 100 per cent rag stock. A paper which has been treated with special oils to increase

its transparency is called vellum by the trade. Its oiliness makes it difficult to work with. Tracing cloth is made of a high grade of cotton cloth especially treated to make it translucent and capable of receiving ink without having the ink strike into the cloth. One side of this cloth has a dull satin finish; the other side is slick and shiny. The dull side is the better one upon which to draw, since the ink spreads more evenly upon it. Water dissolves the preparation used in making the cloth, and great care must be exercised at all times not to get any water upon it either before or after tracing. A water spot cannot be inked over, and it will always show in the blueprint.

When permanent records are desired and where a tracing will be handled a great deal, it is best to make the tracing with ink upon tracing cloth. The method of making such a tracing will now be explained. Pencil tracings, of which many are now being used, will be discussed in another unit.

HOW TO MAKE AN INK TRACING ON CLOTH

Place the tracing cloth over the completed pencil drawing with the dull side of the cloth up. Fasten it securely at the corners with thumb tacks, making sure that the cloth is stretched tight so that it does not buckle or wrinkle at any place. Be careful in this process that the pencil drawing is kept lined up with the T-square. To this end it is best to tack down the pencil drawing, first making sure of its alignment, then put the cloth on by removing one tack at a time and putting it back through both the cloth and the drawing sheet.

It will be found that tracing cloth frequently seems to have a somewhat oily surface which causes the ink to gather up into little globules as a line is ruled, thus making a very poor-looking line. To remedy this condition an especially prepared powder called "pounce" may be rubbed over the surface. Chalk dust or magnesium carbonate will do just as well. The powder absorbs the oil and leaves the surface in better condition for inking.

After all parts of the surface have been covered, rub off the powder very carefully so that none remains on the cloth to clog up the pen point. Once the surface has been thoroughly prepared, as described above, keep the palms of the hands off it as the natural oiliness and perspiration of the hands will again spoil the surface.

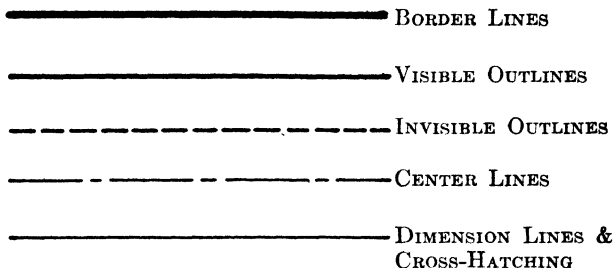

FIG. 1. Proper weight of lines.

The proper weight of lines is shown in Fig. 1 for your convenience, and should be strictly adhered to. To save time, ink the lines in the order given below:

1. Visible outline:
 - (a) Arcs and circles.
 - (b) Horizontal lines, beginning at the top of the sheet.
 - (c) Vertical lines, beginning at the left of the sheet.
 - (d) Inclined lines, working across the sheet from the left.
2. Invisible outlines in the same order as for visible lines.
3. Center lines and dimension lines in the same order as for visible lines.
4. Arrow-heads, figures, notes and titles.

When you see that a tracing is going to require more than one day to complete, work entirely upon one view at a time, completing each view before going to the next. This is neces-

sary because if a change in the moisture content of the air should occur during the time that the tracing was in progress, the tracing might easily shrink or stretch to a point where it would be impossible to bring the partially completed views into alignment with the pencil work, thus making accurate tracing very difficult.

If you make an error in tracing, or if it is desired to change the drawing after the tracing has been completed, the lines in error or those to be changed can be removed with a pencil eraser. This takes a little more time than a grit eraser, but it leaves the surface of the cloth in a smooth condition so that the ink lines can again be drawn over the erased places. If a grit eraser or knife edge is used, the surface will be destroyed, so that the ink will strike into the cloth and spread along the threads, thus ruining the tracing.

QUESTIONS

1. Why is it necessary to make tracings of shop drawings?
2. Which side of the cloth is best to use for tracing? Why?
3. If the ink gathers into little globules instead of spreading smoothly, what can be done?
4. What precaution should be taken after using pounce, chalk dust or magnesium carbonate on tracing cloth?
5. What happens to tracing cloth when the air becomes moist?
6. How should you proceed on a tracing that will require several days to complete?
7. Can changes or corrections be made on a tracing? How?
8. What reason can you give for inking arcs and circles before straight lines, especially where the straight lines are tangent to the arcs?

PROBLEMS

Make a working drawing of an object assigned from the following group. Proceed in the following order:

Make the drawing perfect and complete in pencil as you have learned to do heretofore, then submit it for approval.

Make corrections. Then trace.

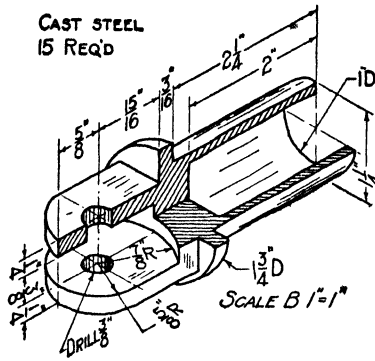

FIG. 2. Swivel pipe attachment.

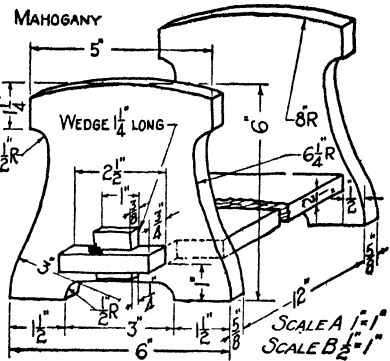

FIG. 3. Book rack.

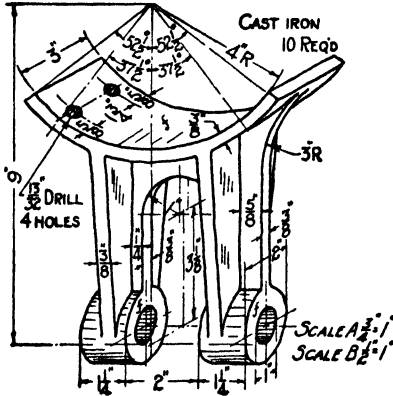

FIG. 4. Conveyor box pinion bearing.

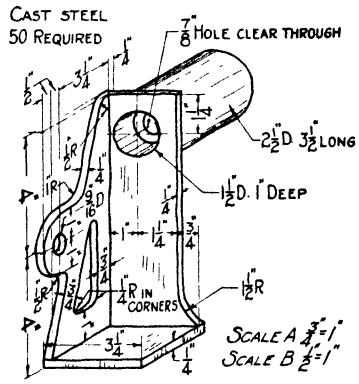

FIG. 5. Joist hanger.

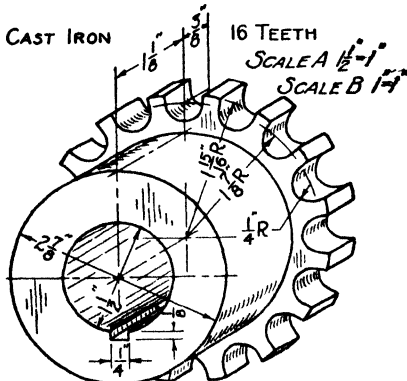

FIG. 6. Flexible coupling.

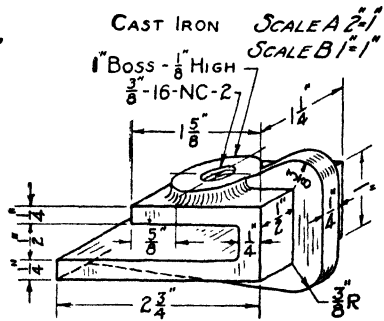

FIG. 7. Conveyor cover clamp.

UNIT XVII

BLUEPRINTING

PURPOSE OF UNIT XVII

The purpose of this unit is to tell something of the history and chemistry of the blueprint process, and how to make blueprints.

WHAT YOU SHOULD KNOW ABOUT BLUEPRINTING

The solution which is used as a coating or a sensitizer for blueprint paper is composed of two salts of iron. The fact that the salts of iron are sensitive to light was first discovered by Sir John Herschel, a British astronomer and scientist, in 1840. It was not until 1876, however, at the



Courtesy of the C. F. Pease Company

FIG. 1. Sun frame for blueprinting.

Centennial Exposition in Philadelphia, that the blueprint process was introduced into the United States as a method of reproducing engineering drawings.

It was at first regarded as "too messy" a process ever to be used widely by engineers. With the gradual improvement of apparatus this objection was overcome, until to-

day blueprinting, or some similar process, is used exclusively throughout the engineering world for the reproduction of drawings.

Blueprint paper is made from a good grade of white paper which must be free from wood pulp and sulphur. It is sensitized on one side with a solution of ammonium citrate of iron and potassium ferricyanide. These two chemicals do not react upon each other in their original state, and hence if a piece of blueprint paper is washed in water before being exposed to light, the two chemicals, which give a pale green color to the paper, simply wash off, leaving the white paper exposed.

If, however, the paper is exposed to light, the ferric salt is reduced to a ferrous state by the liberation of oxygen. In this condition, when placed in water, the two chemicals will react and form a blue precipitate upon the paper called Prussian blue or Turnbull's blue. Upon these facts the making of a blueprint depends. Further facts will be brought out as the process of making a print is explained.

Equipment. The first step in the process is to expose the paper to a strong light, like the sun or an electric arc light, allowing the light to shine through the tracing. This requires some means of holding the tracing and paper in close contact. In the early days an apparatus called a sun frame, as shown in Fig. 1, was used. With the development of the arc lamp, machines have been invented to make use of this source of

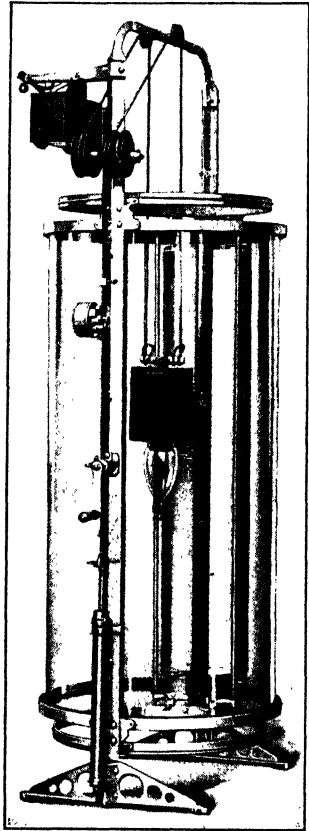

Courtesy of The C. F. Pease Co.

FIG. 2. Vertical electric blueprinting machine.

light. An example of such a machine is shown in Fig. 2. The paper and tracing are held tightly against the glass cylinder by means of a canvas curtain. The arc light moves

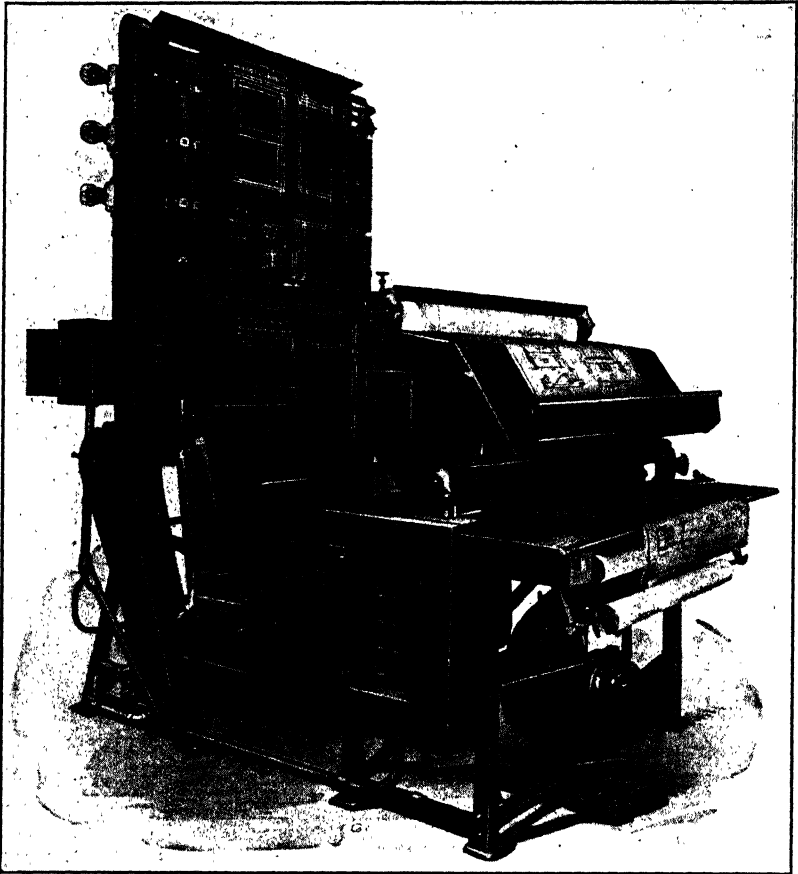

Courtesy of The C. F. Pease Co.

FIG. 3. Continuous electric blue printing machine, washer and dryer.

vertically through the cylinder, thus giving an even exposure to the paper.

Some of our large manufacturing plants use millions of square feet of blueprint paper each year. This demand for quantity production has led to the development of the so-

called continuous blueprint machine, one type of which is illustrated in Fig. 3.

HOW TO MAKE A BLUEPRINT

Exposure. The first requirement for a good blueprint is a good tracing. Place the tracing on the sensitized side of the paper (the green side) with the ink lines of the tracing away from the paper. Then place both in the printing machine (of whatever type) with the tracing next to the glass, so that the light must pass through the tracing before reaching the paper. Expose the paper to the light for the proper length of time. This will have to be determined by trial. Small strips of paper are usually used and tested for different periods of time, from a little less than a minute to two or three minutes, until a deep blue color is obtained. Once the proper time has been established for a given machine and a given grade of paper, this experiment need not be repeated, since the time will be constant.

Developing. After exposure, remove the tracing and the paper from the machine and carefully lay the tracing aside where it cannot get water upon it. Wash the paper in a tray of water for two or three minutes. If the exposure was properly made, the lines of the drawing will appear white upon a deep blue background. The white lines are produced because the ink lines of the tracing protected the chemicals on the paper from the light, and therefore left them unchanged, hence they simply wash off leaving the white paper exposed, whereas at all other parts of the sheet the chemicals were changed and produced a blue precipitate upon the paper.

After developing, the print may be hung up to dry. In the continuous blueprinting machine the entire process is accomplished by the machine, which usually has an electric or gas drier.

Over-exposure. If by chance the paper was over-exposed and the reduction process was carried too far, a grayish blue color results instead of a deep blue. Some of the lines of the

drawing may also disappear because the light has finally penetrated the dark lines of the tracing.

Under these conditions, the print may be restored to a good condition by washing it in an oxidizing bath or, in other words, reversing the reduction process caused by the light and restoring a little of the oxygen. Any active oxidizing agent will do. Potassium bichromate is most frequently used, however. After washing in the oxidizing solution the print should again be rinsed in water, then hung up to dry.

Sometimes changes or corrections are desired on prints. If very many copies are required, the cheaper process will be to change the tracing and make new prints. If only a few copies are necessary and the changes are not extensive, white ink, which can be obtained commercially, may be used. In the absence of white ink a strong solution of sodium bicarbonate (baking soda) may be used in the ruling pen, or lettering pen, to produce white lines upon the blue background.

QUESTIONS

1. When was the process of blueprinting first invented, and by whom?
2. When was it first introduced into the United States?
3. What was the general attitude toward it?
4. To what extent are blueprints used today?
5. If a print has been over-exposed, what can be done to restore it?
6. Of what two chemicals is the sensitizing solution of blueprint paper composed?
7. Name the three steps in making a blueprint.
8. Explain the relative position of the tracing, paper and source of light in making an exposure.
9. Which way should the ink lines of the tracing be, relative to the paper?
10. How is the proper length of time for exposure determined? How often must this be determined for a given machine and grade of paper?
11. How can changes be made upon blueprints?

PART II

UNIT XVIII

GEOMETRICAL CONSTRUCTION

PURPOSE OF UNIT XVIII

The purpose of this unit is to show how to construct regular polygons and how to make constructions for tangency in problems which frequently occur in drawing practise, also how to draw the helix.

WHAT YOU SHOULD KNOW ABOUT THE GEOMETRICAL CONSTRUCTIONS OF THIS UNIT

A regular polygon is a plane figure having equal sides and equal angles. The sum of the interior angles is equal to $N - 2$ straight angles, where N equals the number of sides and a straight angle is an angle of 180 degrees. The construction of Fig. 5 depends upon this fact. The names of some polygons and the number of sides in each are given below:

| | |
|-------------------|-------------------|
| Triangle, 3 sides | Heptagon, 7 sides |
| Square, 4 sides | Octagon, 8 sides |
| Pentagon, 5 sides | Nonagon, 9 sides |
| Hexagon, 6 sides | Decagon, 10 sides |

The construction for the problems of Figs. 10 to 14 inclusive depends upon the definition of a circle, which is simply that it is the locus (location) of points at a given distance from a point. The method of approach to any tangency problem involving the circle, then, is to determine the intersection of two loci. To illustrate, if a circle of 1-inch radius is to be drawn tangent to a straight line, the center of the circle must lie on one of two straight lines,

A and B , parallel to the first line O and 1 inch from it, as shown in Fig. 1a.

In the same way, if a circle of 1-inch radius is tangent (externally) to another circle N , the center of the circle must be on a third circle M which is everywhere 1 inch away from the second. This, of course, is a concentric circle whose radius is equal to the sum of the radii of the two tangent circles, as shown in Fig. 1b.

Now if a circle must be tangent to a straight line and also to another circle, both conditions still hold true, and so the center must be at the intersection of the straight

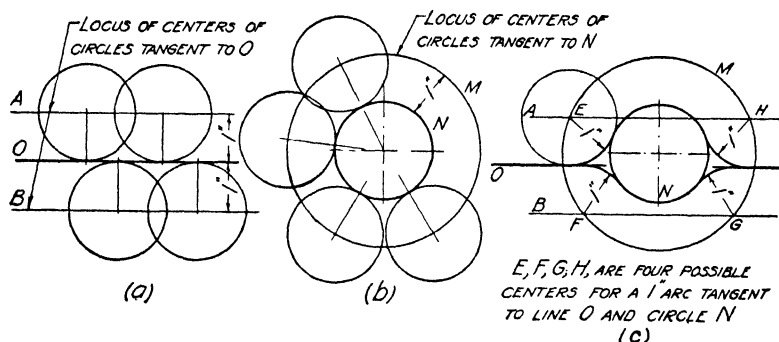

FIG. 1. Construction of an arc tangent to a circle and straight line.

lines A or B and the circle M . See Fig. 1c. Other problems of this kind can and should be reasoned out in the same way.

HOW TO MAKE THE GEOMETRICAL CONSTRUCTIONS OF THIS UNIT

1. **To construct a square having given the length of one side.** At the desired position lay off a line AB equal to the side of the square. At A and B erect perpendiculars to the line, and from B measure off on the perpendicular a distance equal to AB by means of a compass or with dividers. From the point C thus located, draw a line parallel to AB until it intersects the perpendicular from A . See Fig. 2.

2. **To construct a square having the center given, also the length of the side and the direction of one side.** At the

specified center draw a circle having a diameter equal to the length of a side. Then draw two lines parallel to the given direction and tangent to opposite sides of the circle. Draw two other lines tangent to the circle and perpendicular to the specified direction. See Fig. 3.

3. To construct a pentagon within a given circle. Draw the circle and its horizontal and vertical center lines. Bisect the right half of the horizontal center line, thus locating point *A*. See Fig. 4. With *A* as a center, and *AB*, the distance to the intersection of the vertical center line and the circle, as a radius, draw the arc *BC*. The distance *BC* is equal to the length of the side of the inscribed pentagon.

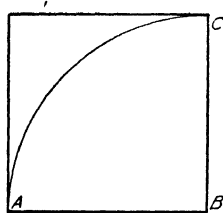

FIG. 2.

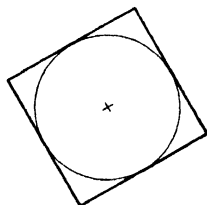

FIG. 3.

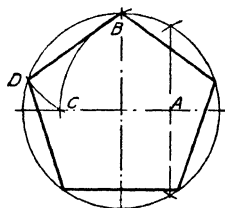

FIG. 4.

Beginning at *B*, step off this distance around the circle. A high degree of accuracy is required for this construction.

4. To construct a regular polygon of any number of sides, having the length of the side given. With a line equal to the length of the side as a radius, draw a semicircle. Divide the semicircle accurately by trial into the same number of parts as there are sides to the polygon. From the center *A* draw radial lines of indefinite length through these division points as shown in Fig. 5. Then with *B* as a center, describe an arc of radius *AB*, cutting the first radial line at *C*. Then with *C* as a center and the same radius, draw an arc cutting the next line, and continue until the figure is complete. Great accuracy is required to make this solution check out. All pencil and compass lines should be hair lines. As a check, the perpendicular bisectors of the first two sides laid out may be found. These will intersect at the center of a circle passing through all the corners of the polygon.

5. To construct a regular polygon of any given number of sides within a given circle. Draw the circle and divide the horizontal diameter into the same number of equal parts as there are sides to the polygon, as shown in Fig. 6. With the ends of the diameter A and B as centers, and a radius equal to the diameter, strike arcs that intersect at D . Through D and the second division point from A draw a line intersecting the circle at C . AC , then, is the length of the side of the polygon, which may be stepped off around the circle.

6. To construct an octagon having the length of a side given. Draw the line AB of the required length. Then with

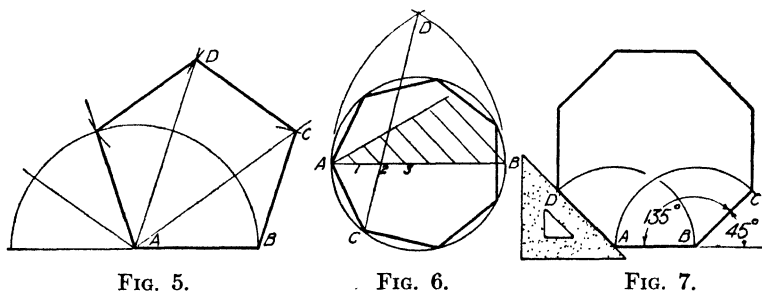

FIG. 5.

FIG. 6.

FIG. 7.

the 45-degree triangle draw lines making an angle of 135 degrees with AB as shown in Fig. 7. Step off the length of AB on these lines. Through the points C and D thus formed, erect perpendiculars to AB , and again step off the length, of the side. Continue as indicated in Fig. 7.

7. To construct a hexagon having given the length of a side. Draw the line AB of the required length, and then from points A and B draw lines making angles of 120 degrees with AB . With a divider, step off on these lines the length AB , thus locating C and D . From these points draw lines making 120 degrees with AC and BD , and again step off the length of the side. Close the hexagon. See Fig. 8.

The construction of Fig. 9 may also be used, since the distance across corners, as A to D , F to C , etc., is just twice the length of a side.

8. To construct a hexagon having given the distance across corners. Draw a circle having the distance across the corners as a diameter. With the radius used in drawing the circle, step off six equal chords which form the sides of the hexagon. See Fig. 9.

9. To construct a hexagon having given the distance across flats, that is, the distance between opposite sides, as AF

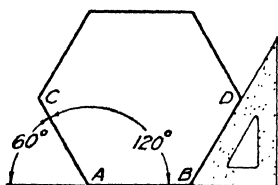

FIG. 8.

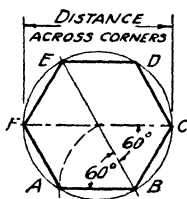

FIG. 9.

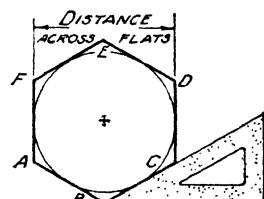

FIG. 10.

and DC . Draw a circle having a diameter equal to the specified distance. Draw two vertical lines AF and CD tangent to the circle with the T-square and triangle, then the two 30-degree lines EF and BC tangent to the circle with the T-square and 30-degree triangle. Finally, draw the 30-degree lines DE and AB in the same manner by simply reversing

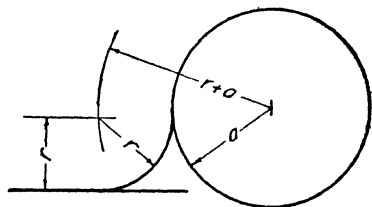

FIG. 11. Arc tangent to a straight line and circle.

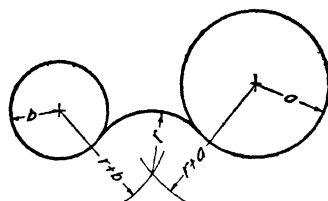

FIG. 12. Arc tangent to two circles. Case 1.

the position of the triangle, thus completing the figure. See Fig. 10.

10. To draw an arc of a given radius r tangent to a circle of radius a and to a straight line. See Fig. 11. With a radius equal to the sum of the radii of the given circle and arc ($r + a$), draw an arc concentric with the given circle. Draw a line parallel to the given line and at a distance r from it.

The intersection of this line and the arc is the center of the tangent arc.

11. To draw an arc of radius r tangent to two circles.
CASE 1. Arc tangent externally. Add the distance r to the radius of each circle and describe an arc concentric with each circle as shown in Fig. 12. The intersection of these arcs is the required center of the tangent arc. **CASE 2.** Arc tangent internally. Subtract the radius of each circle from r and describe arcs concentric with the circles as shown in Fig. 13. The intersection of these arcs is the required center of the tangent arc. **CASE 3.** Arc tangent internally to one circle and externally to the other. For the circle tangent externally, add its radius to r and describe a concentric arc.

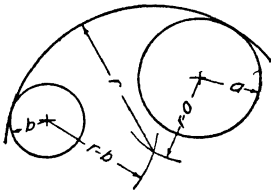

FIG. 13. Arc tangent to two circles. Case 2.

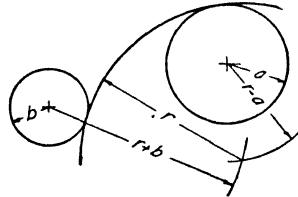

FIG. 14. Arc tangent to two circles. Case 3.

For the circle tangent internally, subtract its radius from r and describe a concentric arc. The intersection of these two arcs locates the center of the tangent circle. See Fig. 14.

12. To connect two parallel lines by a reversed curve, the radii a and b of the two curves being given. Select the point of tangency to one of the lines at A as shown in Fig. 15 and erect a perpendicular to the line. With the radius b describe an arc tangent to the line at A . The center, of course, will be on the perpendicular. From this point on, the problem is the same as shown in Fig. 11, where it was required to draw an arc tangent to a given circle and a straight line.

13. To draw a helix. By definition a helix is the path of a point which moves about a line at a fixed distance from it with constant angular velocity and which, at the same

time, moves parallel to the line with constant velocity. Thus a point might move through 30 degrees around the line and travel parallel to the line $\frac{1}{8}$ inch. Figure 16 illustrates the construction. One view of the path of the point is a circle. On this view the angular position can be plotted; on the other view, the linear position will show. Thus, in Fig. 16, if *a* is the original position of the point which has a movement as described above, *b* will be its position when it has moved through 30 degrees and *c* its position after 60 degrees. By plotting a sufficient number of points and drawing a smooth curve through them, the helix is represented. The

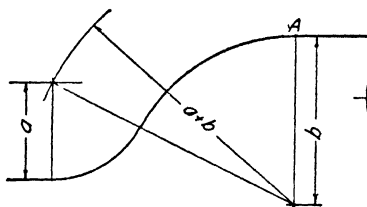

FIG. 15. Joining parallel lines by a reverse curve.

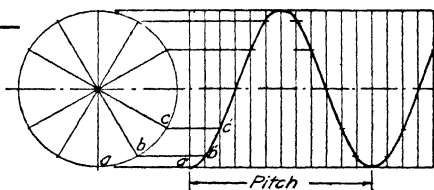

FIG. 16. Construction of helix.

distance the point moves along the axis in one revolution is called the pitch of the helix.

QUESTIONS

1. What is meant by a regular polygon?
2. What is the name of a regular polygon of seven sides; of five sides?
3. Make a freehand sketch and explain how to draw an arc of 1-inch radius tangent to another circle and a straight line.
4. Make a sketch and explain how to draw an arc of 1-inch radius tangent to two other circles, both circles to be outside of the tangent arc.
5. Make a sketch and explain how to draw an arc of 3-inch radius tangent to two smaller circles, both small circles to be inside the tangent arc.
6. Define the meaning of the term "helix."
7. What is meant by the pitch of a helix? Illustrate by a sketch.
8. Name the regular polygons having from three to ten sides.
9. Make a sketch and explain how to draw an arc tangent to two circles. One circle shall be inside the arc, the other outside.

PROBLEMS

Lay out the standard border line and title space, then divide the sheet into four equal rectangles by means of a horizontal and a vertical center line.

Do the problems assigned from the following group. Make your own original layout of the problem in light lines with a 4H pencil. Arrange each problem so that it will occupy the center of the space in which it is placed. If you see that this will not happen the way you have begun, note what changes will be necessary, then erase what you have made and begin again.

The objective is not merely a series of geometrical constructions but a well-balanced drawing sheet as well. This requires thoughtful planning; therefore think before you draw.

1. (a) Construct a pentagon which shall be $1\frac{1}{2}$ inches on a side.
 (b) Draw a hexagon which shall be 2 inches across flats.
 (c) Draw a circle of 1-inch radius with its center near one end of a horizontal line. Construct an arc of 1-inch radius tangent to the circle and the line.
 (d) Draw one turn of a helix whose radius is $\frac{3}{4}$ inch and whose pitch is 3 inches.
2. (a) Construct a heptagon inside of a 3-inch-diameter circle.
 (b) Construct an octagon 1 inch on a side.
 (c) Draw a circle of $\frac{1}{2}$ -inch radius with its center $2\frac{1}{2}$ inches from another circle of $\frac{3}{4}$ -inch radius. Draw an arc of $1\frac{1}{2}$ -inch radius tangent to these circles externally.
 (d) Draw two parallel horizontal lines 2 inches apart. Connect them by 2 arcs of $1\frac{1}{2}$ - and 2-inch radii, respectively.
3. (a) Construct a square 2 inches on a side with the base making an angle of 30 degrees with the horizontal.
 (b) Construct a nonagon within a 3-inch-diameter circle.
 (c) Draw a circle of $\frac{1}{2}$ -inch radius 2 inches from another of $\frac{3}{4}$ -inch radius, and draw one arc of 3-inch radius tangent to them so that the circles are inside the arc.
 (d) Draw one and one-fourth turns of a helix of $1\frac{1}{4}$ -inch diameter and $2\frac{1}{2}$ -inch pitch.
4. (a) Construct a pentagon within a $2\frac{1}{2}$ -inch circle.
 (b) Draw a heptagon which shall be $\frac{3}{4}$ inch on a side.
 (c) Draw a circle $\frac{1}{2}$ inch in radius, 2 inches from another whose radius is $\frac{3}{4}$ inch. Draw a circle of 2-inch radius tangent to them so that the $\frac{3}{4}$ -inch circle is inside the arc and the $\frac{1}{2}$ -inch circle is outside it.
 (d) Draw two parallel horizontal lines $2\frac{1}{2}$ inches apart and connect the lines by a reverse curve. One arc is to have a 2-inch radius, and the points of tangency are to be 3 inches apart horizontally. Devise your own solution.

UNIT XIX

ORTHOGRAPHIC PROJECTION. READING A DRAWING

PURPOSE OF UNIT XIX

It is the purpose of this unit to teach you how to read a two- or three-view orthographic projection by:

1. Locating one point on an object relative to another.
2. Determining the position of lines relative to the principal planes and recognizing when they show in true length.
3. Determining the position of plane faces of an object relative to the principal planes and recognizing when a face shows in its true shape.

WHAT YOU SHOULD KNOW ABOUT POINTS, LINES AND PLANES

All solid objects of which drawings are made for the purpose of construction are bounded by combinations of points, lines, planes and curved surfaces. In the process of construction it is necessary to know the relationship between these things. As a preliminary to still further study one must learn to distinguish the relationships listed above. The pictorial views are added here merely as an aid in reading but will not be referred to in the following discussion since the draftsman or workman must be able to read the two- and three-view orthographic projections.

Location of points. Let it be required to locate point E with reference to G in Fig. 1. From the top view it can be seen that E is $\frac{1}{2}$ inch to the left of G and $\frac{3}{4}$ inch in front of it. The top view does not show which point is higher, but this fact may be learned from the front view where the vertical projections of these two points show E to be $\frac{1}{2}$ inch below G . This completely locates the point with reference to G . The profile, or side, view repeats a part of the infor-

mation given in the top and front views. From the side it is evident that E is $\frac{1}{2}$ inch below and $\frac{3}{4}$ inch in front of G . Other points should be studied in the same way.

Position of lines. A line may have any one of three distinctive positions relative to the horizontal, vertical and profile planes. It may be (1) parallel to any one of them, (2) perpendicular to one or (3) inclined to all three. The simplest way to determine the relationship of a line to a plane is to get an edgewise view of the plane.

Lines parallel to planes. This relationship can be determined by inspection of the projection showing an edgewise

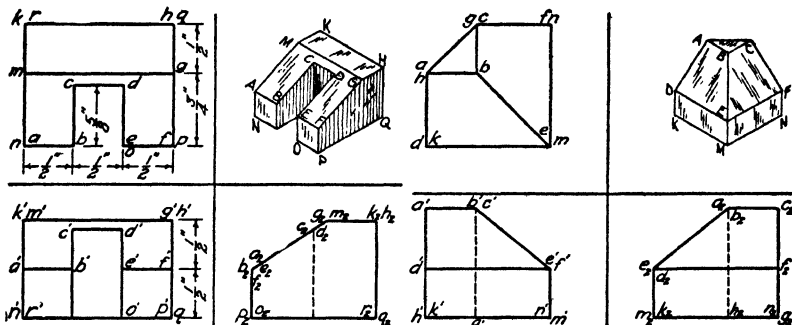

FIG. 1. Notched block.

FIG. 2. Beveled block.

view of the plane. Thus in the top view of Fig. 2 the vertical and profile planes appear edgewise, in the so-called ground lines, and the lines DE , KM , AB , CF and others are seen to be parallel to V while EF , BC , HK and AD are parallel to P .

In the front view of the same figure, the same ground lines now represent the horizontal and profile planes edgewise, and here the lines AB , AC , DE and many others are seen to be parallel to H while EM , AH and CG are observed to be parallel to P . In the profile view the ground lines represent the H and V planes seen edgewise, and similar observations may be made.

If a line is parallel to a plane, the projection on that plane shows the true length of the line. Line CF shows in its true length in $c'f'$, since the line is parallel to V . Line

AD shows in true length in a_2d_2 , since the line is parallel to P . Line AC shows in true length in ac , since the line is parallel to H . Hence the true length of every line in Fig. 2 except the line BE is shown in at least one of the views. A method for finding the true length of this line will be explained in a later unit.

Lines perpendicular to planes. If a line is perpendicular to a plane, the projection on that plane will be a point. Conversely, if the projection of a line on a plane is a point, then the line is perpendicular to the plane. This fact enables us to determine when a line is perpendicular to a plane by one view alone, namely, when the view shows a point projection for the line. The edgewise view of the plane alone would not determine this situation.

An examination of the top view of Fig. 2 shows the lines AH , CG , FN , EM and DK to be perpendicular to H . It is observed that, if a line is perpendicular to one of the coordinate planes, it must be parallel to the other two, and hence shows in true length upon both of them.

Lines inclined to planes. To study lines inclined to planes the edgewise view is again most useful, although it does not give the exact angle of inclination. A study of the three views of Fig. 2 shows BE to be the only line which is inclined to all three planes. The angles which this line makes with the planes, however, do not show in their true value anywhere. We know simply that the line is inclined, but not how much.

Position of planes. A plane face of an object may have one of three distinctive positions relative to H , V and P . It may be (1) parallel to any one of them, (2) perpendicular to one or (3) inclined to all three. The edgewise view offers again the best means of determining these relationships.

Parallel planes. If two plane faces appear edgewise in the same view, their relationship to each other is revealed at once. Thus in Fig. 2 the front view shows the plane faces ABC and $HKGMN$ to be parallel to H , and the faces $ADHK$ and $EFMN$ to be parallel to the profile. In the top view the

faces $CGFN$ and $DKEM$ are shown parallel to V . If a plane is parallel to one of the coordinate planes, it is of course perpendicular to the other two.

Perpendicular planes. If a plane face of an object appears edgewise in any projection, then the face is perpendicular to that plane of projection. Thus, in Fig. 3, from the top view it can be seen that $CDEPO$ is perpendicular to H . In the front view, faces AGB and $ADEF$ are shown to be perpendicular to V , and in the side view, faces $ABCD$ and AFG are shown perpendicular to P . All the planes mentioned above are inclined to the other two planes and hence do not show in their true size in any view.

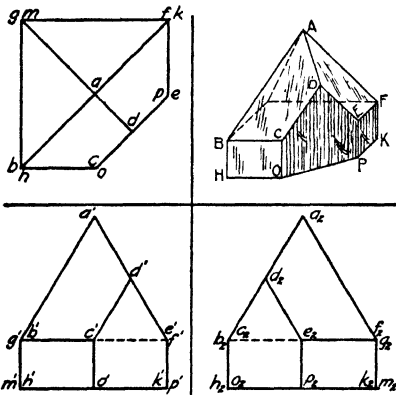

FIG. 3. Cut pyramid.

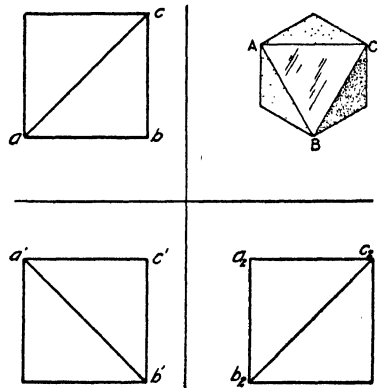

FIG. 4. Beveled block.

Inclined planes. The third position a plane may have is to be inclined to all three of the principal planes. The plane face ABC of the object in Fig. 4 represents such a plane. It does not show edgewise in any of the three views and hence may be easily identified.

The recognition of edgewise views of plane faces of objects is important, since it is this fact which gives depth to the views. The draftsman must learn to think of his views, not as mere plane geometric figures, but rather as particular aspects of the solid object. Two of the dimensions are parallel to the plane of projection and the third perpendicular to it.

HOW TO READ TWO- AND THREE-VIEW ORTHOGRAPHIC PROJECTIONS

To read two- and three-view projections, the first thing is to determine what information you wish to get from the drawing. The second is to know where to look for it.

Look at the top view to get: (1) distances or dimensions, right or left and front or back, (2) lines or planes parallel to V or P , (3) lines or planes perpendicular to H , (4) true length of all lines parallel to H , (5) true shape of all faces parallel to H .

Look at the front view to get: (1) distances or dimensions, up or down and right or left, (2) lines or planes parallel to H and P , (3) lines or planes perpendicular to V , (4) true length of lines parallel to V , (5) true shape of faces parallel to V .

Look at the side view to get: (1) distances or dimensions, up or down and front or back, (2) lines or planes parallel to H and V , (3) lines or planes perpendicular to P , (4) true length of lines parallel to P , (5) true shape of faces parallel to P .

QUESTIONS

1. Under what conditions will the projection of a line show its true length?
2. What must be the relationship of a plane face of an object to the plane of projection if the projection shows the true shape of the face?
3. How can you tell whether a line is perpendicular to one of the planes of projection?
4. How can you tell whether a plane is perpendicular to one of the planes of projection?
5. How can you tell whether a line is parallel to the H plane?
6. How can you tell whether a line is parallel to the V plane?
7. Which of the principal planes of projection show edgewise in the ground lines when one is looking at the top view?
8. Which of the principal planes of projection show edgewise in the ground lines when one is looking at the side view?
9. At which view would you look to tell whether one point was above or below another?

10. At which view would you look to tell whether a point was to the right or left of another?

PROBLEMS

Lay out the standard border line and title space, then rule three sets of guide lines for $\frac{5}{32}$ -inch letters. The guide lines are to be arranged in groups of 3, 7 and 7 in such a manner as to make a well-balanced sheet.

On those guide lines, letter the answers to the following questions concerning points, lines and planes for the object assigned from the following group. All projections are lettered with small letters in proper fashion. In your answers, however, you will use capital letters, since you are referring to the actual points and lines in space and not to the projections. Scale the drawing at $\frac{1}{4}$ "-1" for all dimensions. Scale to the nearest $\frac{1}{32}$ ".

The following examples taken from Fig. 1 will illustrate the method:

A is $\frac{1}{2}$ inch to the left of *B*, at the same level and at the same distance from *V*.

There are no lines parallel to *H* and inclined to *V*.

There are no lines parallel to *V* and inclined to *H*.

AM, *FG*, *BC* and *DE* are parallel to *P* and inclined to *H*.

KMGH and *ROQ* are parallel to *H*.

AMGF is perpendicular to *P* and inclined to *H*.

As an aid in visualizing these blocks it may be helpful to make pictorial freehand sketches on coordinate paper as suggested in Unit X. This should not be done, however, unless it is absolutely necessary.

Points

1. Describe the location of *A* with reference to *B*.
2. Describe the location of *B* with reference to *C*.
3. Describe the location of *C* with reference to *D*.

Lines

1. Name the lines that are parallel to *H* and inclined to *V*.
2. Name the lines that are parallel to *V* and inclined to *H*.
3. Name the lines that are parallel to *P* and inclined to *H*.
4. Name the lines that are perpendicular to *H*.
5. Name the lines that are perpendicular to *V*.
6. Name the lines that are perpendicular to *P*.
7. Name the lines that are inclined to all planes.

Planes

1. Name the planes that are parallel to *H*.
2. Name the planes that are parallel to *V*.
3. Name the planes that are parallel to *P*.

4. Name the planes that are perpendicular to H and inclined to V .
5. Name the planes that are perpendicular to V and inclined to H .
6. Name the planes that are perpendicular to P and inclined to H .
7. Name the planes that are inclined to H, V and P .

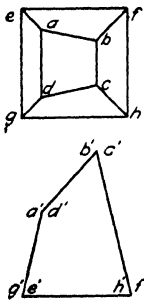

FIG. 5.

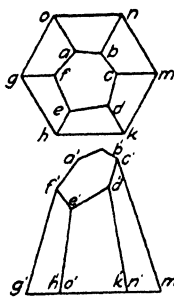

FIG. 6.

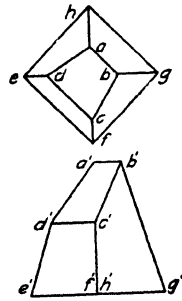
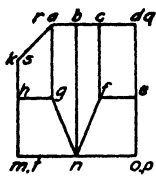
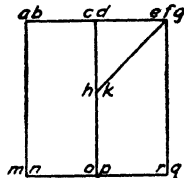

FIG. 7.



LETTER PROFILE VIEW



LETTER PROFILE VIEW.

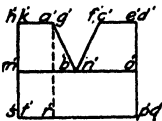

FIG. 8.

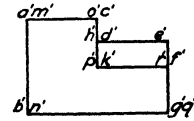
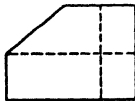

FIG. 9.

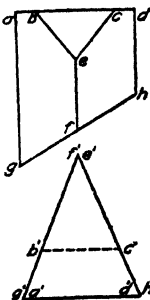
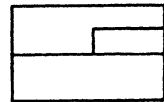

FIG. 10.

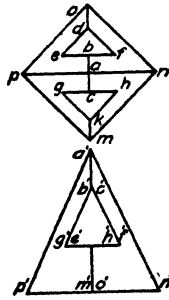

FIG. 11.

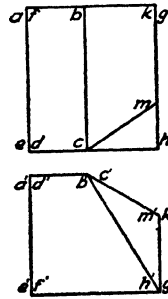
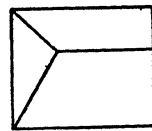
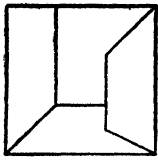
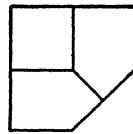

FIG. 12.





LETTER ALL VIEWS



LETTER ALL VIEWS

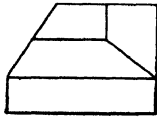
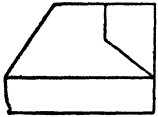

FIG. 13.

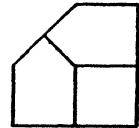
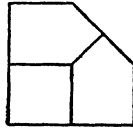
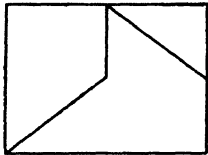
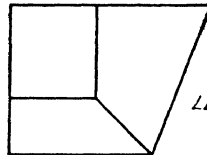

FIG. 14.



LETTER ALL VIEWS



LETTER ALL VIEWS

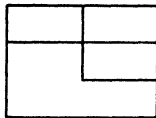
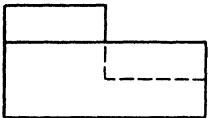

FIG. 15.

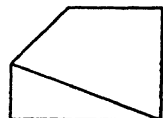
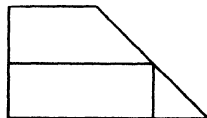

FIG. 16.

UNIT XX

ORTHOGRAPHIC PROJECTION. AUXILIARY VIEWS AND PLANES

PURPOSE OF UNIT XX

The purpose of this unit is to show how to make auxiliary views and how to find the true length of lines and the true shape of plane faces of objects.

WHAT YOU SHOULD KNOW ABOUT AUXILIARY VIEWS AND AUXILIARY PLANES OF PROJECTION

PLANES OF PROJECTION

Why auxiliary views are needed. As was pointed out in the last unit, certain kinds of lines and plane faces on some objects do not show in their true length or shape in the three principal views. In construction, however, it is frequently necessary to know four things about lines and planes as follows:

1. The true length of inclined lines.
2. The angle between lines.
3. The true shape of plane faces.
4. The angle between plane faces.

The first two of these items can be obtained in finding the third. That is to say, when the true shape of a plane face is obtained,

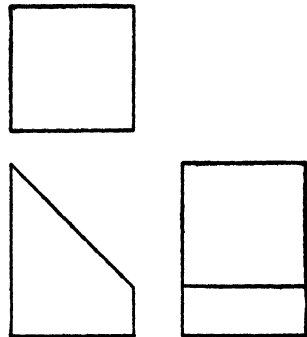

FIG. 1. Truncated prism.

we have the true length of all lines in it, and the true value of the angles between them. As an illustration of the first three points, it will be noted that, in the truncated prism of Fig. 1, the sloping face does not show in its true size

in any one of the views. If this object were to be made of sheet metal, it would be necessary to know the true shape of this face. This true shape can be obtained by means of an additional view called an auxiliary view. In fact, all four items above can be obtained for any object, no matter how complicated, by means of one or two auxiliary views.

Position of auxiliary plane. In order to serve its purpose, the auxiliary plane must satisfy two conditions. First, if it is to show the true shape of a plane face, it must be parallel to that face. In all our previous work this was accomplished by placing the object so that its faces were parallel to the three principal planes; but with many objects, such as the simple prism shown in Fig. 1, this cannot be done. Hence, to accomplish our purpose we set a plane parallel to the face of the object as shown pictorially in Fig. 2. The projection on this plane then will show the true shape of the face.

In order to make the construction of views possible, the auxiliary plane must be perpendicular to one of the planes on which we have projections or views. This will enable us to use the same rules of projection that we learned for the other three views, in which case it will be remembered the planes were also at right angles to each other. Neither of these two conditions can be violated if useful projections are to be made.

This second condition makes it necessary to have an edge-wise view of a plane face before the auxiliary plane can be set parallel to it. This condition, however, is easily met for most objects by properly selecting the position of the object for making the principal views.

Figure 3 shows the auxiliary plane parallel to the sloping face and perpendicular to the V plane. Here it can be seen that the distance of the various points in the auxiliary view from the auxiliary ground line $1-3$ is the same as the distance of these points from the horizontal ground line $0-1$ or the profile ground line $1-2$. Obviously, these distances must be the same, for in each case they represent exactly

the same thing, namely, the distance of the object behind the vertical plane.

HOW TO MAKE AN AUXILIARY VIEW

Marking of ground lines and projections. The same system of marking which was explained in Unit X will be used. The planes are given the numbers 0, 1 and 2 for *H*, *V* and *P*, respectively. The first auxiliary is then numbered 3. Ground lines are given the numbers of the planes which form them. In Fig. 3, the projections are lettered with small letters having subscripts corresponding to the number of the plane of projection. Auxiliary projections will therefore have the sub-

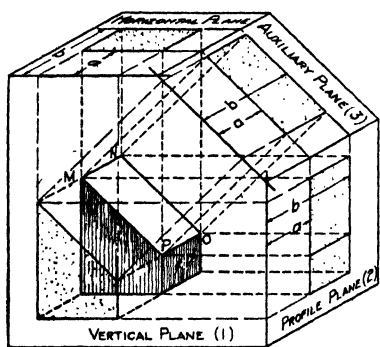

FIG. 2. Pictorial sketch of auxiliary plane and projections.

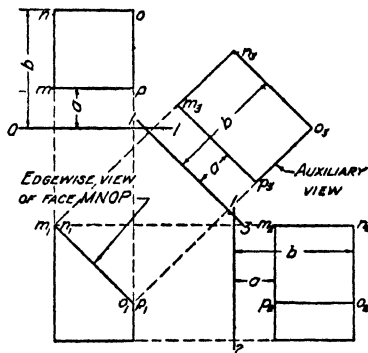

FIG. 3. Auxiliary view on plane perpendicular to the vertical plane.

script 3. The prime mark (') may also be used on the vertical projection instead of the subscript 1. See Fig. 6. The subscript for *H* being 0 is omitted.

Constructing the views. Draw first the two or three principal views, as may be required, in the usual fashion. These views should be selected so that one of them will show the edgewise view of the plane whose true shape is to be found. The front view of Fig. 3 shows the sloping face of the prism as a straight line at m_1, n_1, o_1 and p_1 .

Next draw the auxiliary ground line at a convenient place parallel to the edgewise view of the plane face, as at 1-3 in Fig. 3. From the corners of the face, m_1, n_1, o_1, p_1 , draw

perpendiculars to the auxiliary ground line, of random length. On these perpendiculars, measure distances from the auxiliary ground line equal to the distances of the points in the top view from the $O-1$ ground line. These distances are represented by a and b in Fig. 3. This locates points m_3, n_3, o_3, p_3 , which may now be connected to form the true shape of the face, thus giving the true length of all lines in the face and the true value of the angles between them.

Figure 4 represents pictorially a case where the auxiliary plane is perpendicular to H , and Fig. 5 represents the same

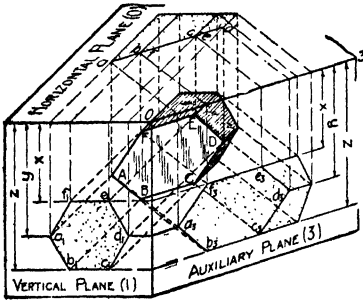

FIG. 4. Pictorial sketch of auxiliary plane and projections.

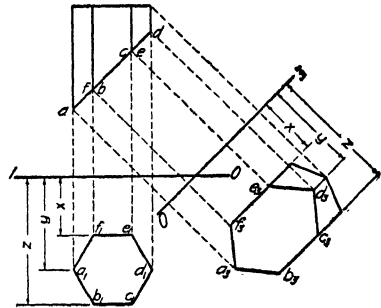

FIG. 5. Auxiliary view on plane perpendicular to the horizontal plane.

situation in orthographic form. Here again it will be noted that the auxiliary ground line is placed parallel to the edge-wise view of the face whose true shape is desired. The perpendiculars are drawn from the edgewise view, and the measurements x, y and z , in this case, obtained from the other view. Study these figures carefully until the scheme is thoroughly understood.

HOW TO FIND THE PROJECTIONS OF TRUNCATED GEOMETRICAL SOLIDS

Geometrical solids which have been cut off in some manner by a plane as shown in Fig. 6 are said to be truncated. Such truncated solids occur in drawing problems and practice, and it becomes necessary to find the appearance of

one or more views when the cutting plane appears edgewise in other views.

When a plane surface appears edgewise, the point in which a line passes through it can be seen by inspection in that view. The remaining projections of this point can be determined by the simple fact that the projections of the point must lie on the projections of the line since the point itself is on the line.

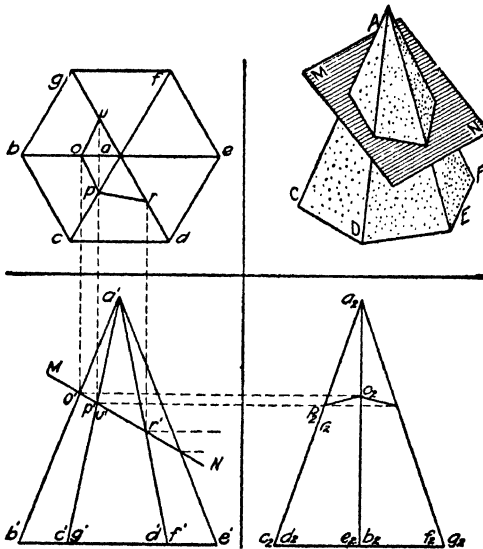

FIG. 6. Construction of side and top views of truncated faces.

In Fig. 6 notice that the line AB can be seen to pass through the plane MN at o' . Now the horizontal projection of the point represented by o' in the front view must be on the horizontal projection of the line AB , since the point itself is on line AB . Therefore erect a perpendicular from o' until it intersects ab in the top view; this locates o . In the same way o_2 must be on a_2b_2 in projection with o' . In like manner find all the points in which the edges of the solid pierce the cutting plane in the top and side views, and connect them. Then erase the top part of the pyramid, thus leaving the correct views of the truncated solid.

Note: The views have not been completed in Fig. 6, nor has the top part been removed, since the actual construction is better shown in this manner.

QUESTIONS

1. What is the purpose of an auxiliary view in machine drawing?
2. Under what conditions should an auxiliary view be made?
3. What is the relationship of the auxiliary plane to the face of the object which shows upon it in true shape?
4. What must be the relationship of the auxiliary plane to one of the principal planes of projection?
5. Why must the auxiliary plane be perpendicular to one of the principal coordinate planes?
6. If a line on an object is inclined to all three principal planes, how may its true length be obtained? Illustrate. (See line *CD* in Figs. 4 and 5.)
7. What two conditions must an auxiliary plane of projection always fulfill?
8. How are ground lines marked?
9. How are the various projections marked to distinguish them?
10. If the auxiliary plane is perpendicular to *H*, from which view then are the measurements obtained for constructing the auxiliary view?

PROBLEMS

Lay out the standard border line and title space. Divide the drawing sheet vertically into two equal rectangular spaces, and then find the true shape of the lettered face of the object assigned from the following group:

In each case, construct first the front and top views as indicated, then set up the auxiliary ground line and make the auxiliary projection which will show the true shape of the lettered face. Include the entire object in the auxiliary view as a matter of practise. The location of the object on the sheet is shown by dimensions from the horizontal center line and from the edge of the drawing space. Omit all dimensions on your drawing.

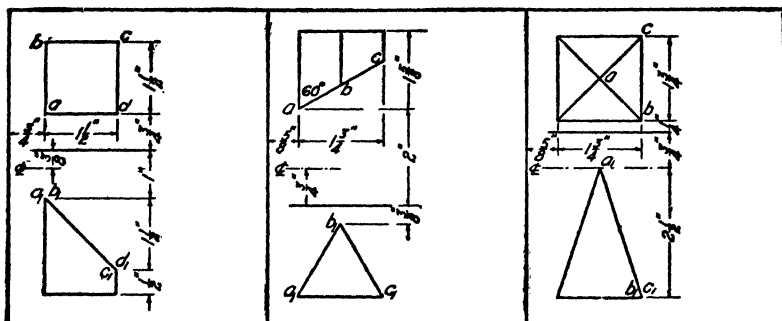

FIG. 7.

FIG. 8.

FIG. 9.

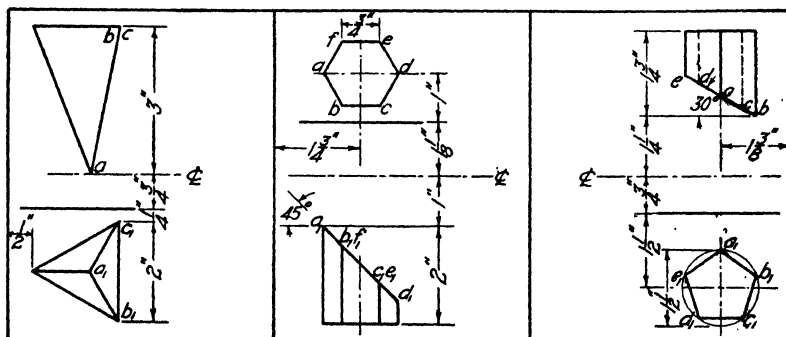

FIG. 10.

FIG. 11.

FIG. 12.

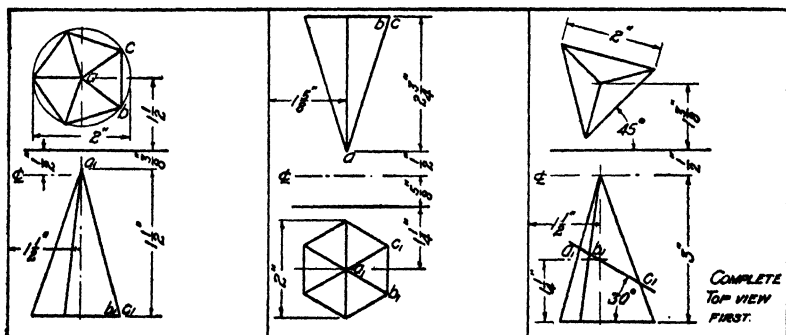

FIG. 13.

FIG. 14.

FIG. 15.

COMPLETE
TOP VIEW
FIRST.

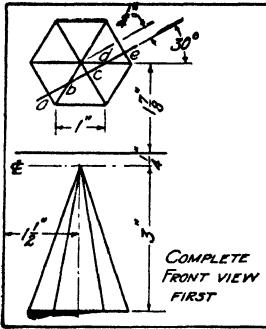

FIG. 16.

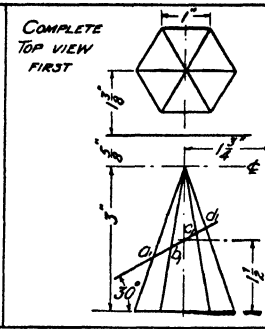

FIG. 17.

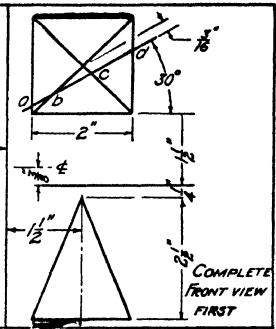

FIG. 18.

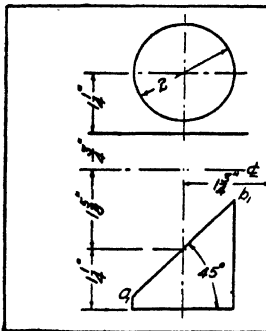

FIG. 19.

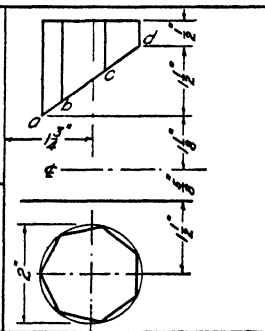

FIG. 20.

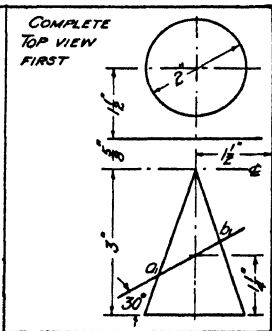

FIG. 21.

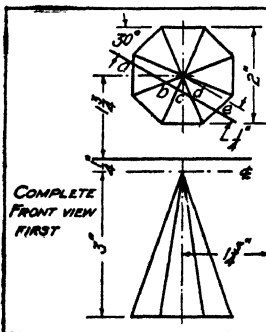

FIG. 22.

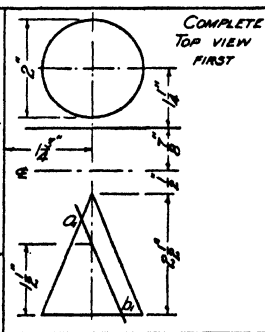

FIG. 23.

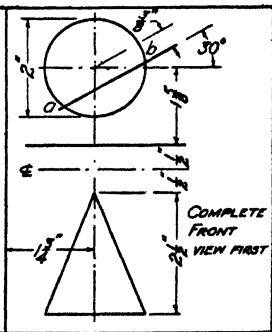

FIG. 24.

UNIT XXI

SOLVING PROBLEMS WITH AUXILIARY VIEWS

PURPOSE OF UNIT XXI

The purpose of this unit is to show how to solve problems by means of auxiliary views.

WHAT YOU SHOULD KNOW ABOUT AUXILIARY VIEWS

In some problems which arise in the commercial drafting room it is not possible to construct the principal views by themselves. It then becomes necessary to set up an auxiliary plane and work back and forth between the views, getting a projection in one that could not be obtained in the other,

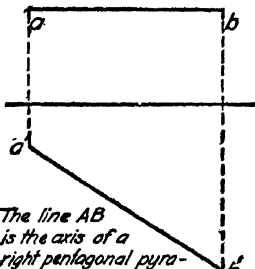

The line AB is the axis of a right pentagonal pyramid. A is the apex and B the center of the base which is inscribed in a 2 dia. circle. One side of the base is parallel to the horizontal plane. Draw the horizontal and vertical projections of the pyramid.

FIG. 1. Problem stated.

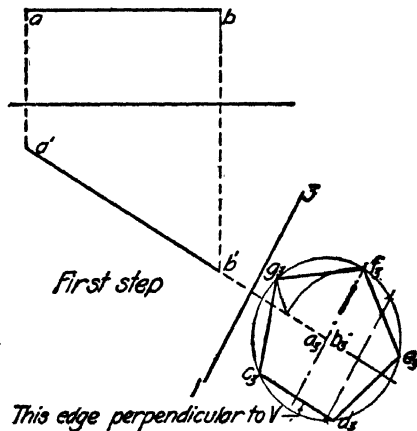

FIG. 2. Auxiliary plane set up. Base drawn.

and thus finally completing the problem. The problem shown in Fig. 1 illustrates a situation of this kind. For the illustration and problem of this unit the simple geometric figures will be used so that attention may be given entirely to the problem of projection.

After a little study of the problem in Fig. 1 it becomes

evident that we cannot draw either the top or the front view, since we cannot determine the length of any line in them, except the one edge of the base which is parallel to H , nor the position of a single line including the one just mentioned. We must, therefore, resort to some other device, and the auxiliary plane offers the most practical method of solution.

Method of attack. In solving problems which are partially or entirely verbal in character, one must proceed to read the problem over carefully, visualizing accurately the shape of the object and so far as possible the position of every line in it relative to the planes of projection.

In studying the problem above, we observe at once that the axis is parallel to the vertical plane and hence the base will be perpendicular to V since it is a right pyramid. This being the case, an auxiliary plane may be set up which will be parallel to the base and upon which the base will show in true shape. The line AB will project upon this plane as a point which will be the center of the base and around which the pentagon may be drawn by the usual construction. Since the problem specifies that one side of the base shall be parallel to H this side will be perpendicular to V , and hence the position of the pentagon is known. Since this side is perpendicular to V it will be drawn perpendicular to the ground line $1-3$, which is the edgewise view of the V plane when looking at the auxiliary view. Figure 2 shows this construction. The ground line $1-3$ may be drawn at any convenient place beyond b' , and it must be perpendicular to $a'b'$.

A line which represents the edgewise view of the base may now be drawn through b' perpendicular to $a'b'$. From the auxiliary view the corners of the base may be projected back to this line. When these corners $c'd'e'f'$ and g' are connected with a' the front view is complete, as shown in Fig. 3.

The third and last step is the completion of the top view. Having the edgewise view of the base in the vertical projection and the true shape in the auxiliary projection the top view may be constructed from these two by erecting

perpendiculars from c' , d' , e' , f' and g' and measuring off the distances x , y , z , etc., above the ground line equal to the distances of the corresponding points from the auxiliary ground line. In both views these measurements represent the distance of the points behind the V plane. Connecting a with c , d , e , f and g completes the top view. It should be noted that the edges from the vertex to c and d are on the

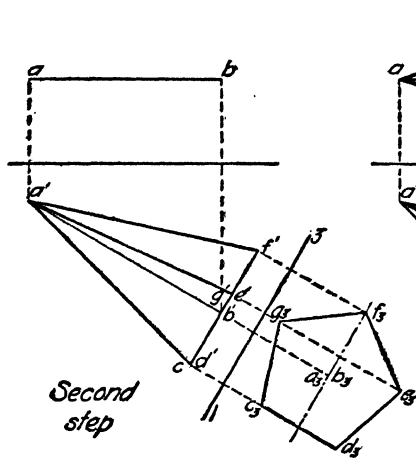

FIG. 3. Front view completed from auxiliary view.

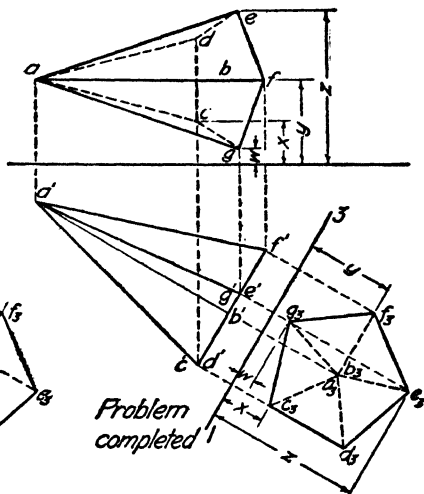

FIG. 4. Top view constructed. Drawing completed.

under side of the object and are hence invisible in the top view, as are also the lines cd , cg and de .

HOW TO USE THE AUXILIARY PLANE IN SOLVING PROBLEMS

From the verbal or other description of the problem obtain a clear mental image of the object.

Visualize its position in space, noting the significant positions of its lines and plane faces relative to the planes of projection, that is, the parallel and perpendicular relationships which enable you to attack the problem by setting up the auxiliary plane. Draw as much as possible of the two or three necessary principal views, and then set up the auxiliary plane and draw the auxiliary view according to the specifications of the problem.

Work back from the auxiliary view to the next adjoining one, and then to the next, until the problem is complete.

QUESTIONS

1. What further use may be made of auxiliary views in addition to showing the true size of faces of an object?
2. What is the first step in the solution of a verbal problem?
3. What is the next step in the solution of a problem after the shape of the object has been clearly visualized?
4. After the shape and position of the object have been clearly visualized which lines of the object may be drawn?
5. In what way does the auxiliary plane assist in solving problems?
6. If the face of an object is inclined to H and perpendicular to V , to which of the coordinate planes will the auxiliary be made perpendicular?
7. If a line is perpendicular to H what is its relation to V ?
8. If a line lies in a plane which is perpendicular to V and the line is parallel to H , what is its relation to V ?
9. If a line is parallel to H and a plane is perpendicular to it, what is the relation of the plane to H ?

PROBLEMS

Lay out the standard border lines and title space; then divide the sheet into two equal parts by a vertical line and do the problems assigned from the following group. Be sure to show properly the visible and invisible lines. In determining visibility, the plane of projection is always between you and the object.

In the following problems, the line AB is the axis of a right prism or pyramid, cone or cylinder. In the case of pyramids and cones, the end a is the apex. The short line marked ¢ represents the horizontal center line of the sheet, and the dimensions enable you to locate your ground line for a well-balanced sheet.

The descriptions have been made as brief as possible. In all cases you are to find the front and top views and any other necessary views. Scale full size.

All figures apply to each verbal problem. Use the one assigned by your instructor.

1. Triangular pyramid. Base equilateral, inscribed in a $1\frac{3}{4}$ -inch circle. One edge of base parallel to H .
2. Square prism. Base 1 inch on a side; two edges of base make 30 degrees with H .
3. Triangular prism. Base equilateral, inscribed in a $1\frac{1}{2}$ -inch circle. One face of prism parallel to V .
4. Square pyramid. Base $1\frac{1}{2}$ inches on a side, edges of base make 45 degrees with H .

5. Pentagonal prism. Base inscribed in $1\frac{3}{4}$ -inch circle. One edge of base perpendicular to V .

6. Hexagonal pyramid. Base 1 inch on a side; two edges of base parallel to H .

7. Hexagonal prism. Base $\frac{3}{4}$ inch on a side; two edges of base parallel to V .

8. Right circular cone. Base 2 inches in diameter.

9. Right circular cylinder. Base $1\frac{1}{2}$ inches in diameter.

10. Pentagonal prism. Base inscribed in a $1\frac{3}{4}$ -inch diameter circle; one edge of base parallel to H .

11. Heptagonal pyramid. Base inscribed in a $1\frac{3}{4}$ -inch diameter circle; one edge of base parallel to V .

12. Octagonal pyramid. Base inscribed in a $1\frac{3}{4}$ -inch diameter circle; two edges of base parallel to H .

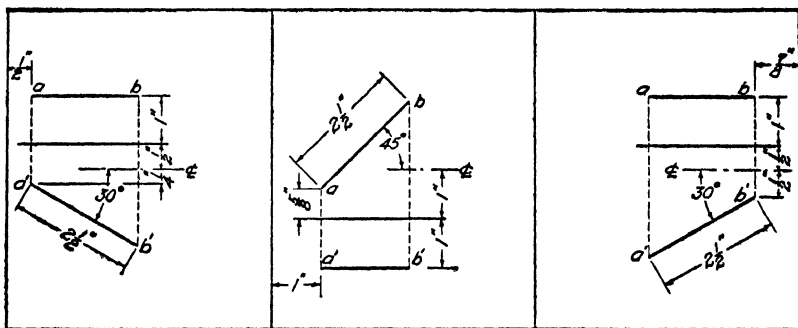

FIG. 5.

FIG. 6.

FIG. 7.

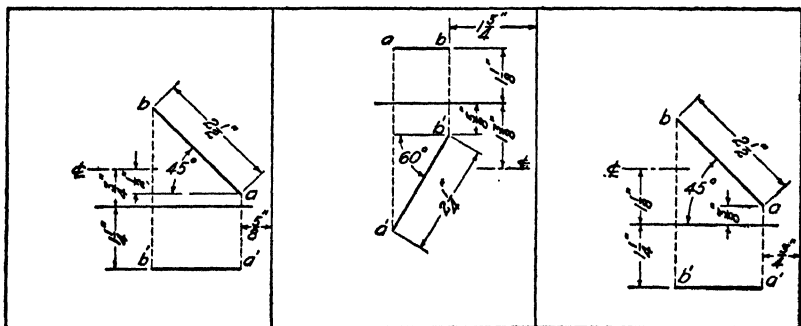

FIG. 8.

FIG. 9.

FIG. 10.

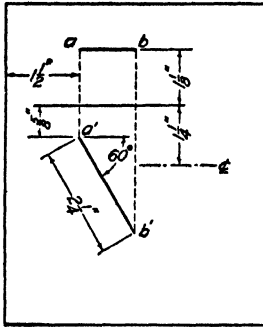

FIG. 11.

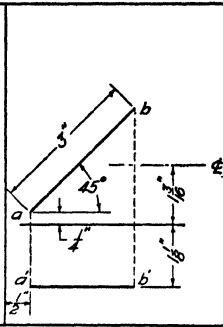

FIG. 12.

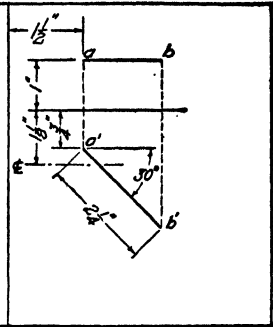

FIG. 13.

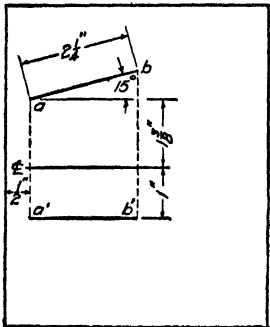

FIG. 14.

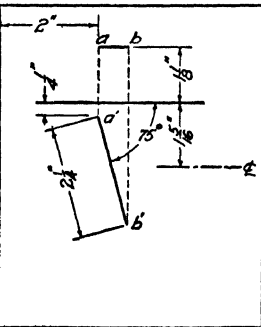

FIG. 15.

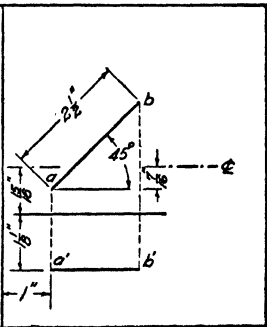

FIG. 16.

UNIT XXII

AUXILIARY VIEWS IN SHOP DRAWINGS

PURPOSE OF UNIT XXII

The purpose of this unit is to show how to make auxiliary views for shop drawings.

WHAT YOU SHOULD KNOW ABOUT AUXILIARY VIEWS IN SHOP DRAWINGS

Auxiliary views are employed in making working drawings both as an aid to the construction of all views necessary to describe the shape, and also to show the true shape of some faces for the purpose of dimensioning.

Omission of ground lines. In making working drawings, or shop drawings, ground lines are never shown because they limit the arrangement of views very materially and add nothing to the description of the shape of the object. The distance of an object from the planes of projection has no bearing at all upon the construction of the object.

Although the ground lines representing the planes of projection may be eliminated from the drawing, it is necessary, nevertheless, to substitute for them certain reference planes from which measurements may be made. These reference planes may be actual faces of the object or imaginary planes of symmetry. A plane of symmetry is an imaginary plane passing through an object in such a manner as to divide the object into two equal and exactly similar parts, as *MN* in Fig. 3. In all cases, however, these planes of reference must be parallel to the plane of projection which would have been used had the ground line been placed on the drawing. An illustrative problem will make this point clear.

A simple truss block is shown pictorially in Fig. 1 in its proper relation to *H*, *V*, *P* and the auxiliary plane which

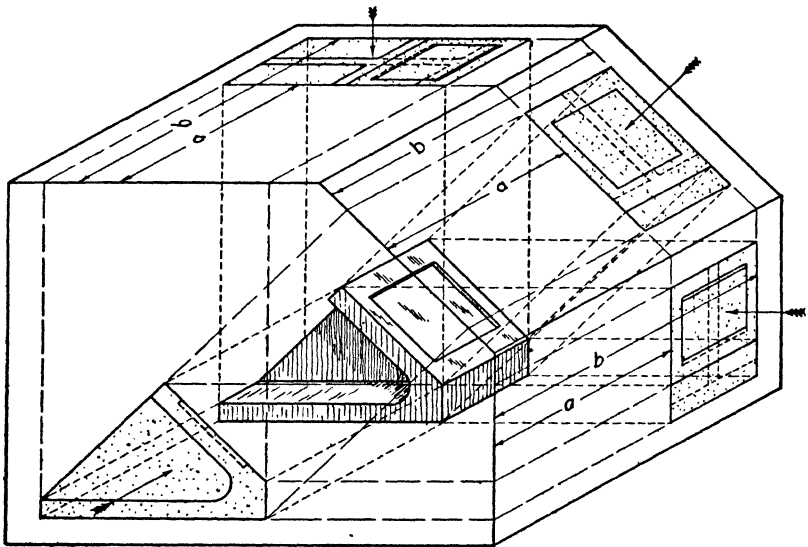

FIG. 1. Pictorial sketch of truss block and projections.

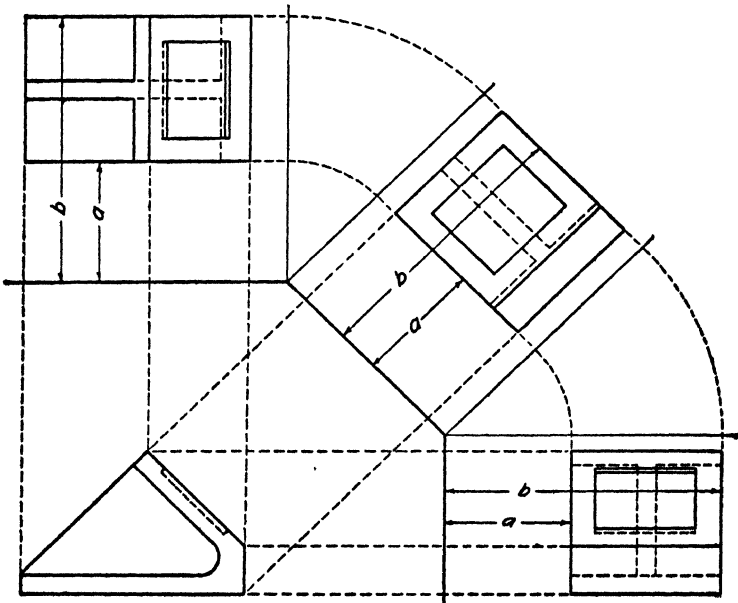

FIG. 2. Orthographic views of truss block shown in Fig. 1.

gives the true shape of the sloping face. In Fig. 2 the orthographic views are shown with ground lines and distances to correspond to the arrangement shown in Fig. 1. The waste of space in this case is quite evident.

Now instead of using the vertical plane as a plane of reference a central plane of symmetry, designated by mn , which is parallel to the V plane, might have been used and then the views could have been arranged as in Fig. 3. The center line mn is drawn parallel to the edgewise view of the face whose true shape is to be shown. Measurements are now transferred from the top or side view to the auxiliary

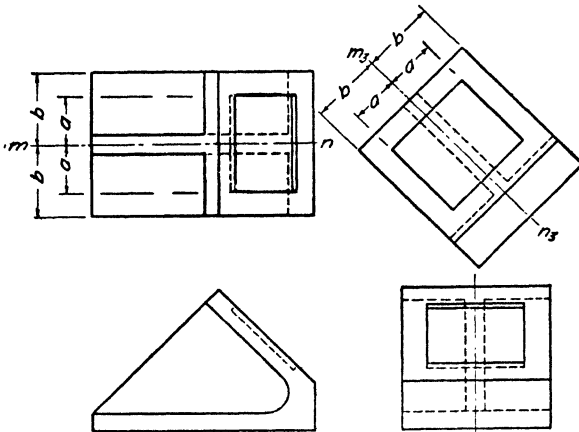

FIG. 3. Orthographic views with ground lines omitted.

view by means of the dividers, using the center line MN as a reference line in these views. Several of these measurements, a and b , are indicated in the figure. Figure 4 represents a case in which an actual face of the object, not an imaginary plane, is used as the plane of reference. In this instance, the bottom face which is parallel to the H plane and is represented by the line mn is the plane of reference. The line m_3n_3 is drawn parallel to the edgewise view of the face it is desired to show, and then measurements are made from this line to correspond to those in the front view.

The views represented in Figs. 3 and 4 are correctly made in all respects as they should be for working drawings. In

the working drawing, only that portion of the object parallel to the auxiliary plane need be shown, since nothing would be added to the clearness of the drawing by reproducing the parts which are not parallel to the plane, and which are already adequately represented in the other two views.

The object of Fig. 4 is again represented in Fig. 5 as a completely dimensioned working drawing. This emphasizes again the fundamental principle that lines and faces of an

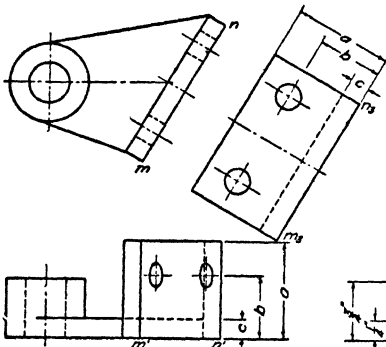

FIG. 4. Orthographic views.
Base used as reference plane.

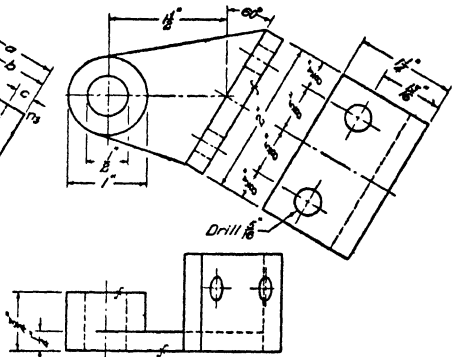

FIG. 5. Dimensioned auxiliary
view.

object must be dimensioned in the views where they show in their true lengths and relationships.

HOW TO MAKE AND USE AUXILIARY VIEWS IN SHOP DRAWINGS

From the model or pictorial view of the object draw the necessary principal views. Complete these as far as possible. (NOTE: In many cases this can be done and the auxiliary view is needed only for dimensioning.)

Parallel to the edgewise view of the face whose true shape is needed, draw the line representing the reference plane (be it plane of symmetry or other plane face). From your knowledge of the true shape of the face lay out the face from the reference plane.

By projection, carry back such points as may be necessary to complete the principal views. This is almost always necessary where curved outlines are involved.

QUESTIONS

1. In making an auxiliary view of one face of an object, how is the auxiliary ground line drawn?
2. From which view of the face (edgewise or area view) are the perpendicular projecting lines erected?
3. From which view (edgewise or area view) are the measurements taken?
4. How may construction of views be carried on if ground lines are not used?
5. What change in laying out dimensions in the auxiliary view is made if a center line is used instead of a ground line?
6. If the object does not have a plane of symmetry which shows edgewise in the auxiliary view, what may be used as a reference plane?
7. What portion of an object should be shown in an auxiliary view, for working drawings?
8. What kind of view of a face must we have before the auxiliary plane can be set up parallel to it.
9. What objection is there to using and showing ground lines in working drawings?

PROBLEMS

Lay out the standard border line and title space, then make a dimensioned drawing of one of the objects assigned from the following group. In the auxiliary view draw only the portion which shows in true shape in the view. Be sure to allow space between views for dimensions. The scale is given with each figure.

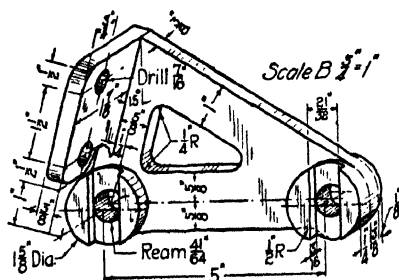

FIG. 6. Link chain attachment.

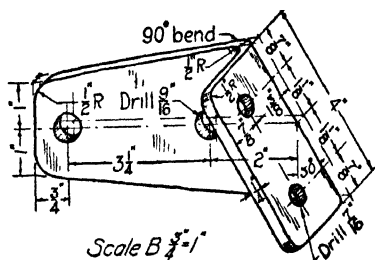

FIG. 7. Link chain attachment.

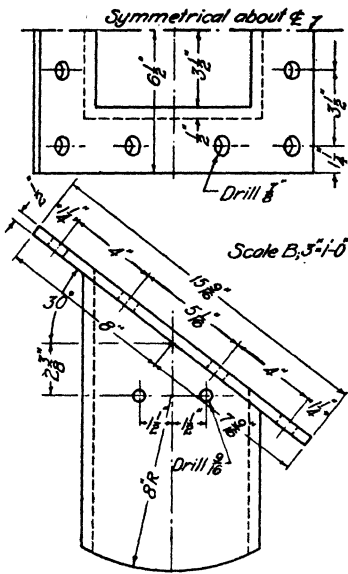

FIG. 8. Angle gate.

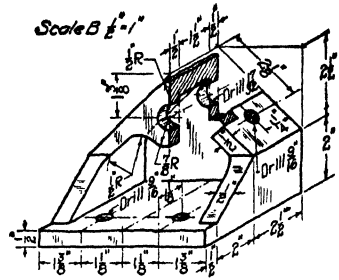

FIG. 9. Belt take-up support.

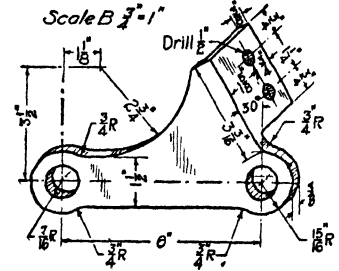

FIG. 10. Link chain attachment.

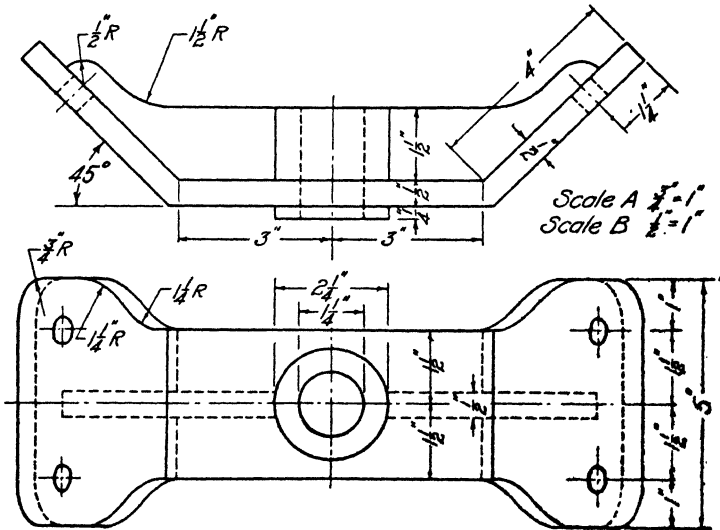

FIG. 11. Shaft support.

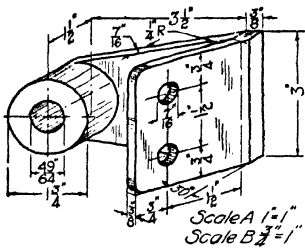

FIG. 12. Angle bearing bracket.

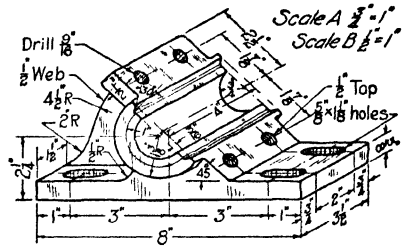

FIG. 13. Angle bearing base.

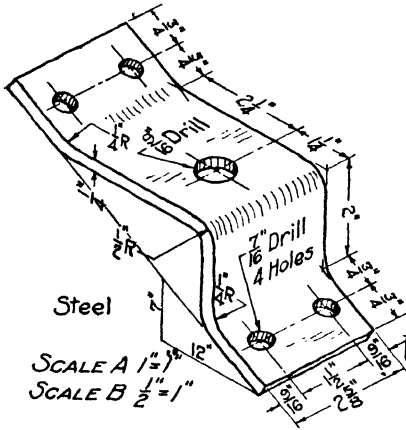

FIG. 14. Inclined bracket.

SCALE A $1\frac{1}{2}$ " = 1", SCALE B $\frac{3}{4}$ " = 1"

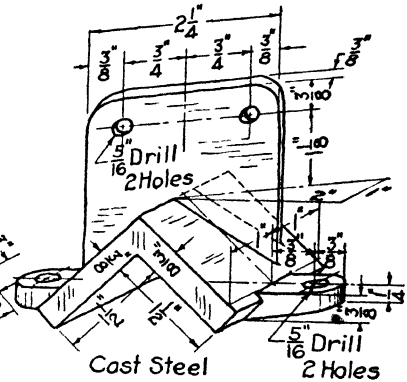

FIG. 15. Conveyor paddle holder.

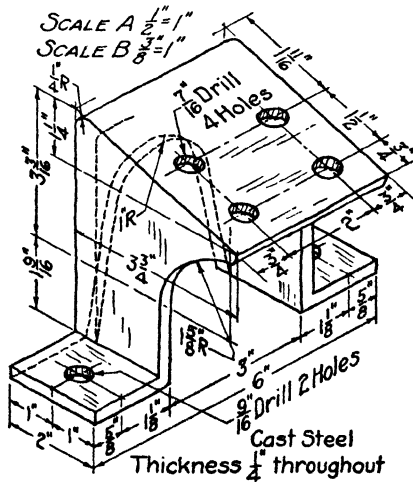

FIG. 16. Conveyor support.

UNIT XXIII

SCREW THREAD FORMS—NATIONAL COARSE AND FINE THREAD STANDARDS

PURPOSE OF UNIT XXIII

It is the purpose of this unit to present the principal facts concerning the standard thread forms and to show how to represent and note them on drawings.

WHAT YOU SHOULD KNOW ABOUT THREADS

The helix, a geometrical curve which was studied in Unit XVII, forms the basis of all screw threads. The sharp V thread, which is perhaps the simplest form, might be thought of as a triangular ridge on a cylinder, formed by cutting a V-shaped groove around the cylinder in helical or spiral fashion. Such a ridge, or thread, is shown in Fig. 1. If the cylinder

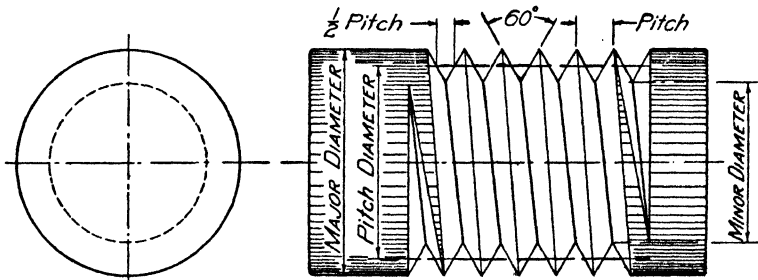

FIG. 1. Single sharp V thread.

thus grooved, or threaded, were cut in two lengthwise, the view obtained would show the cross-section of the thread, and this view is called the profile of the thread. The profile of a sharp V thread is shown in Fig. 2. It will be observed to be an equilateral triangle.

Thread terms. The diameter of the cylinder on which the thread is cut is called the crest or major diameter; that at

the bottom of the thread is called the root or minor diameter; that midway between the root and crest is called the pitch diameter. The pitch of a thread is the same as the pitch of a helix. It is the distance from the crest of one thread to the crest of the next adjacent thread. The pitch is also sometimes specified by giving the number of threads per inch. The meanings of all of these terms are illustrated in Fig. 1.

American (National) Standard threads. Two thread series have been adopted by the American Standards Association. They are called coarse and fine threads. The coarse-thread series is the same as the old U. S. Standard, supplemented in the sizes below $\frac{1}{4}$ inch by a part of the standard estab-

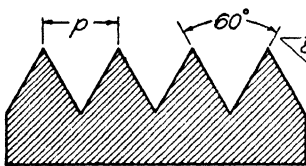

FIG. 2. Sharp V-thread profile.

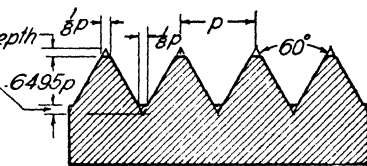

FIG. 3. American (National) form-thread profile.

lished by the A.S.M.E.* in 1907. The fine-thread series ($\frac{1}{4}$ inch to $1\frac{1}{2}$ inches inclusive) is the same as the present regular screw-thread series of the S.A.E.† standard for screw threads established in 1911, supplemented in sizes below $\frac{1}{4}$ inch by the fine-thread series established by the A.S.M.E.

In form they are both similar to the sharp V thread with the exception that the sharp crest has been cut off and the root not cut to a sharp notch. The amount cut off from the top and bottom of the sharp V is one-eighth the total depth, as illustrated in Fig. 3. The slope of the sides is still the same. The difference in the two thread series is chiefly one of pitch. The dimensions have been standardized according

* A.S.M.E. is the abbreviation for the American Society of Mechanical Engineers.

† S.A.E. is the abbreviation for the Society of Automotive Engineers.

to the diameters. Thus a rod of a given diameter will always have the same number of threads per inch if made to the coarse-thread standard. The dimensions of the two series are given in Table I.

TABLE I
COARSE AND FINE THREAD SERIES

| 1 | 2 | 3 | 4 | 1 | 2 | 3 | 4 |
|----------------|-------------------------------|---------------------------------|-------------------------------|-----------------|-------------------------------|---------------------------------|-------------------------------|
| Sizes* | Basic Major Diameter (Inches) | Coarse Series, Threads per Inch | Fine Series, Threads per Inch | Sizes | Basic Major Diameter (Inches) | Coarse Series, Threads per Inch | Fine Series, Threads per Inch |
| 0 | 0.0600 | .. | 80 | $\frac{1}{16}$ | 0.5625 | 12 | 18 |
| 1 | 0.0730 | 64 | 72 | $\frac{1}{8}$ | 0.6250 | 11 | 18 |
| 2 | 0.0860 | 56 | 64 | $\frac{3}{16}$ | 0.7500 | 10 | 16 |
| 3 | 0.0990 | 48 | 56 | $\frac{1}{4}$ | 0.8750 | 9 | 14 |
| 4 | 0.1120 | 40 | 48 | 1 | 1.0000 | 8 | 14 |
| 5 | 0.1250 | 40 | 44 | $1\frac{1}{16}$ | 1.1250 | 7 | 12 |
| 6 | 0.1380 | 32 | 40 | $1\frac{1}{8}$ | 1.2500 | 7 | 12 |
| 8 | 0.1640 | 32 | 36 | $1\frac{1}{4}$ | 1.5000 | 6 | 12 |
| 10 | 0.1900 | 24 | 32 | $1\frac{3}{8}$ | 1.7500 | 5 | 12 |
| 12 | 0.2160 | 24 | 28 | 2 | 2.0000 | $4\frac{1}{2}$ | 12 |
| $\frac{1}{2}$ | 0.2500 | 20 | 28 | $2\frac{1}{8}$ | 2.2500 | $4\frac{1}{2}$ | 12 |
| $\frac{3}{8}$ | 0.3125 | 18 | 24 | $2\frac{1}{4}$ | 2.5000 | 4 | 12 |
| $\frac{1}{4}$ | 0.3750 | 16 | 24 | $2\frac{1}{2}$ | 2.7500 | 4 | 12 |
| $\frac{3}{16}$ | 0.4375 | 14 | 20 | 3 | 3.0000 | 4 | 10 |
| $\frac{1}{8}$ | 0.5000 | 13 | 20 | | | | |

* In the first column the numbers 0 to 12 inclusive are mere standard numbers as: "Size No. 3," etc. Those below No. 12 are fractions of an inch as: " $\frac{1}{4}$ inch."

Multiple threads. In some machine parts where a faster movement is desired than could be produced by the single thread, double, triple and quadruple threads are used. Valve spindles are usually made with one of these multiple threads. A double thread is simply a pair of two separate and distinct threads cut side by side, as illustrated in Fig. 4. One of the threads has been omitted for a few turns at the left end in order to show the two separate grooves more clearly. It should be noted in the double thread that the crest of one thread is directly opposite the crest of the other. When a nut is put on a double thread, at every revolution it travels a distance equal to twice the pitch. A triple thread is formed

by cutting three separate threads side by side as illustrated in Fig. 5. One complete turn of a nut on a triple thread advances it a distance equal to three times the pitch. This distance is called the lead, and it represents the distance the screw advances in one complete turn. The term pitch still has the same meaning as before. In the triple thread, crest is opposite root. The profile of multiple threads is the same

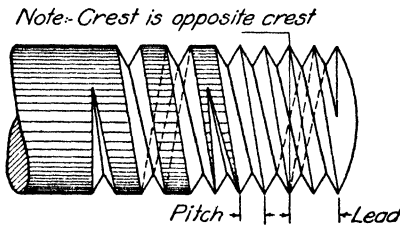

FIG. 4. Double right-hand sharp V thread.

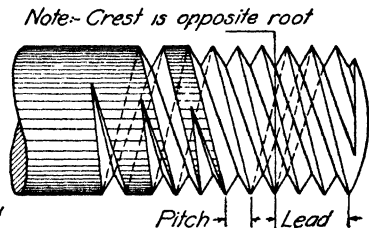

FIG. 5. Triple right-hand sharp V thread.

as for single threads. Multiple threads are referred to as American (National) Form Threads.

Right- and left-hand threads. Thus far no mention has been made of the direction of the screw helix. Obviously the helix might wind around either to the right or left on the rod. This fact gives rise to the so-called right-hand and left-

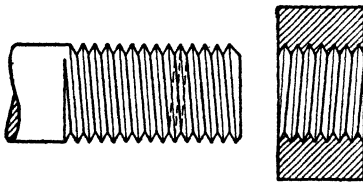

FIG. 6. Large scale symbol. Single right hand thread.

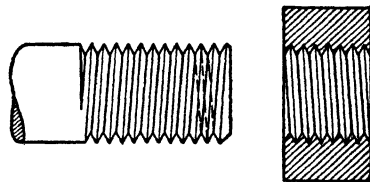

FIG. 7. Large scale symbol. Single left hand thread.

hand threads. The threads represented in Figs. 1, 4 and 5 are right-hand threads. A right-hand thread may be distinguished by the fact that it advances into a threaded hole when turned in a clockwise direction. A right-hand threaded bolt and a nut which has been cut in half to show the inside are shown in Fig. 6. The threads in the bottom

half of the nut slope in a direction opposite to those on the rod, since they must fit the threads which are on the under side of the rod. See the dotted line on the rod.

A left-hand thread is one that advances into a threaded hole when turned in a counter-clockwise direction. A left-hand threaded rod and nut (cut open) are shown in Fig. 7.

HOW TO REPRESENT THREADS

Two methods of representing threads are in common use: one is used for threads of large diameter and the other for small ones. When the actual diameter of the thread upon the drawing is $\frac{3}{4}$ inch or more it will look better if the large-

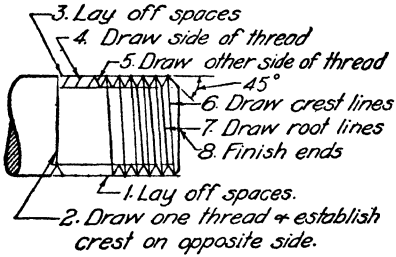

FIG. 8. Laying out large scale symbol.

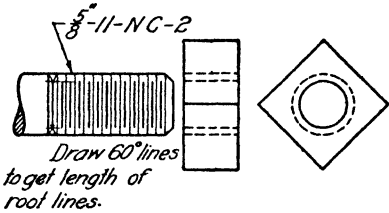

FIG. 9. Laying out small scale symbol.

scale convention is used. For smaller diameters the small-scale convention will be better.

Large-scale conventional thread. The shape of the crest and root of the thread is a helix, but it would take entirely too much time to draw the actual helix, so a conventional scheme has been adopted in which a straight line is substituted for the helix. Figures 4, 5, 6 and 7 have been made in this way. The method of drawing the thread in this manner is shown step by step in Fig. 8.

The V's are made with the 60-degree triangle just like the sharp V, no attempt being made to show the flattening except in very large screws. The position of the crests on opposite sides of the slope of the crest line will show whether the thread is single or double, but when other than a single thread is to be made, the fact should always be noted.

Small-scale conventional thread. As the thread diameters become smaller the V notches are harder to draw, and hence for smaller sizes they are simply omitted and only the lines representing the crest and root are shown. Since this is purely a conventionalization the slope of the lines is also neglected and they are drawn straight across at right angles to the length of the rod as shown in Fig. 9. The method of construction of this symbol is also shown in Fig. 9. The actual number of threads should always be represented to scale up to about 16 per inch. Beyond that number, 16 per inch will be used to represent them. Besides adding to the appearance of the drawing these thread symbols save a great deal of time.

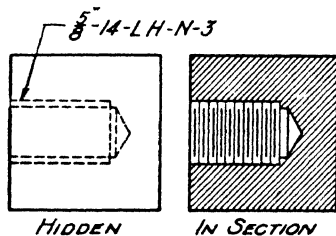

FIG. 10. Threaded holes.

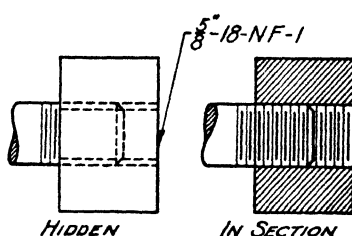

FIG. 11. Rod in threaded hole.

Threaded holes, when the thread is invisible, are shown as in Fig. 9. Tapped holes which are not open at both ends are shown in Fig. 10. When the thread rod is in the hole, it should be as in Fig. 11.

Noting threads. Since thread symbols are so highly conventionalized, they cannot convey exact information, and hence it is necessary to add a note to each thread, giving first its major diameter; second, the number of threads per inch; third, the type of thread, that is, coarse or fine, indicated by the letters *NC* or *NF*; and, finally a number to represent the class of fit. Notes of this character are shown in Figs. 9, 10 and 11.

If the thread is left-hand, the letters *LH* are inserted immediately after the pitch number. If the thread is not of standard pitch, it is called an American National Form thread, and the note specifying it contains only the letter

N instead of *NC* or *NF*. Thus: $\frac{1}{2}$ "-16-*LH-N*-2 means a $\frac{1}{2}$ -inch rod with a left-hand thread, 16 per inch, of American National Form and of Class 2 fit.*

Notes for threads must always give the pitch, regardless of whether this is standard or not. Screw threads will always be regarded as right-hand unless noted *LH* for left-hand.

QUESTIONS

1. Define the motion of a point whose path is a helix.
2. What is meant by the pitch of a helix?
3. Show by a large sketch the profile of the sharp V thread.
4. Show by a large sketch the profile of the American National Standard thread. Give dimensions.
5. Show by a sketch a single right-hand thread.
6. Show by a sketch the meaning of the term pitch as applied to a thread.
7. What is meant by the term "lead" as applied to threads?
8. Show by a large sketch what is meant by the major and minor diameters of a thread.
9. Show by a sketch the conventional symbols for a small-diameter screw thread.
10. How are the number of threads per inch and the type of thread indicated on a drawing?
11. Show by a large sketch a double left-hand thread.
12. Show by a large sketch a triple right-hand thread.
13. When threads are specified by note, what do the letters *NC* and *NF* mean?
14. In looking at a drawing of a large thread that was not noted, how could you tell whether a single, double or triple thread was intended?

PROBLEMS

Lay out the standard border line and title space, and then divide the sheet into four equal rectangles by means of a vertical and horizontal line. In these spaces draw the threads specified in the problem assigned from the following group. In each case show a rod about 3 inches long, 2 inches of which shall be threaded. Look in the tables for the proper number of threads per inch.

1. (a) Two-inch diameter, right-hand sharp V thread.
(b) One-and-three-fourths-inch diameter, left-hand double sharp V thread.

* Class of fits range from loose or No. 1 to close or No. 4 fit.

- (c) Two-and-one-fourth-inch diameter, left-hand American National coarse thread. Show flattened top and bottom of thread.
 - (d) One-half-inch diameter, American National threaded rod and invisible threaded hole. Rod separate from hole. Two views of hole.
2. (a) One-and-three-fourths-inch diameter, left-hand sharp V thread.
- (b) Two-and-one-fourth-inch diameter, right-hand triple sharp V thread.
- (c) Two-inch diameter, right-hand American National coarse thread. Show flattened top and bottom of thread.
- (d) Three-eighths-inch diameter, American National threaded rod part way through a threaded hole which is cut open to show the inside.
3. (a) One-and-one-half-inch diameter, right-hand sharp V thread. Make rod 2 inches long and show hole through a plate 1 inch thick, cut open and threaded to fit rod. Rod not to be in the hole.
- (b) One-and-three-fourths-inch diameter, left-hand double sharp V thread.
- (c) Two-inch diameter, right-hand American National coarse thread.
- (d) Five-eighths-inch diameter, American National fine-threaded rod partly in threaded hole through a plate 1 inch thick. Show the hole invisible.

UNIT XXIV

BOLTS AND NUTS

PURPOSE OF UNIT XXIV

It is the purpose of this unit to teach the proportions of U. S. Standard bolts and nuts and others in common use, and ways of representing and specifying them on drawings.

WHAT YOU SHOULD KNOW ABOUT BOLTS AND NUTS

Use of bolts and screws. Many machine parts must be very firmly fastened together, yet in such a manner that

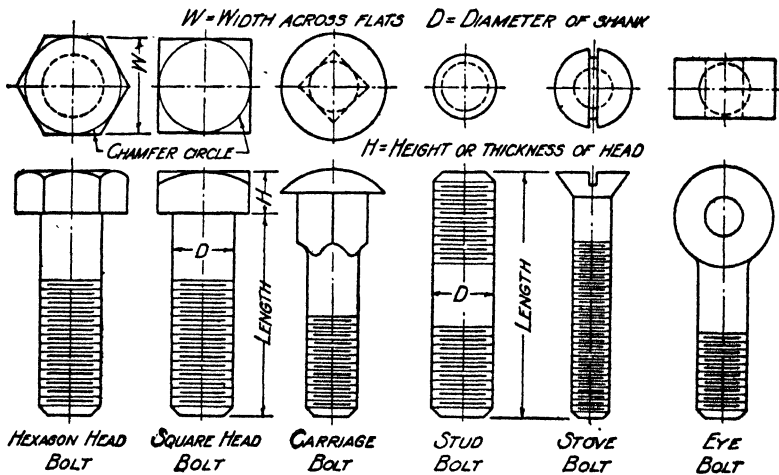

FIG. 1. Common types of bolts.

they can be taken apart again without great difficulty. This is accomplished by means of various types of bolts and screws. Bolts differ from screws chiefly in the fact that the bolt is equipped with a nut whereas the screw fastens directly into a tapped hole in one of the parts being held together. Only bolts will be discussed in this unit.

Kinds of bolts. The different kinds of bolts are distinguished by the shape of the head. Some of the more common varieties are illustrated in Fig. 1. Of these, the U. S. Standard bolt with square or hexagonal head, the carriage bolt, the stud bolt and the stove bolt are perhaps most frequently used.

Dimensions of bolts. The dimensions of bolt heads are always given in terms of some proportion of the diameter of

TABLE I

| Rough and Semi-finished Square and Hexagonal Regular Bolt Heads | | | Finished Square and Hexagonal Bolt Heads | |
|---|--------------------|------------------|--|------------------|
| Diameter of Bolt | Width across Flats | Height | Width across Flats | Height |
| $\frac{1}{4}$ | $\frac{3}{8}$ | $\frac{11}{64}$ | $\frac{7}{16}$ | $\frac{3}{16}$ |
| $\frac{5}{16}$ | $\frac{1}{2}$ | $\frac{13}{64}$ | $\frac{9}{16}$ | $\frac{15}{64}$ |
| $\frac{3}{8}$ | $\frac{9}{16}$ | $\frac{1}{4}$ | $\frac{5}{8}$ | $\frac{9}{32}$ |
| $\frac{7}{16}$ | $\frac{5}{8}$ | $\frac{19}{64}$ | $\frac{3}{4}$ | $\frac{21}{64}$ |
| $\frac{1}{2}$ | $\frac{3}{4}$ | $\frac{21}{64}$ | $\frac{13}{16}$ | $\frac{3}{8}$ |
| $\frac{9}{16}$ | $\frac{7}{8}$ | $\frac{3}{8}$ | $\frac{7}{8}$ | $\frac{27}{64}$ |
| $\frac{5}{8}$ | $\frac{15}{8}$ | $\frac{27}{64}$ | $\frac{15}{8}$ | $\frac{15}{32}$ |
| $\frac{3}{4}$ | $1\frac{1}{8}$ | $\frac{1}{2}$ | $1\frac{1}{8}$ | $\frac{9}{16}$ |
| $\frac{7}{8}$ | $1\frac{5}{16}$ | $\frac{13}{32}$ | $1\frac{5}{16}$ | $\frac{23}{32}$ |
| 1 | $1\frac{1}{2}$ | $\frac{3}{4}$ | $1\frac{1}{2}$ | $\frac{3}{4}$ |
| $1\frac{1}{8}$ | $1\frac{11}{8}$ | $\frac{3}{4}$ | $1\frac{11}{8}$ | $\frac{27}{32}$ |
| $1\frac{1}{4}$ | $1\frac{7}{8}$ | $\frac{27}{32}$ | $1\frac{7}{8}$ | $\frac{15}{16}$ |
| $1\frac{1}{2}$ | $2\frac{1}{4}$ | 1 | $2\frac{1}{4}$ | $1\frac{1}{4}$ |
| $1\frac{3}{4}$ | $2\frac{5}{8}$ | $1\frac{5}{32}$ | $2\frac{5}{8}$ | $1\frac{5}{16}$ |
| 2 | 3 | $1\frac{13}{32}$ | 3 | $1\frac{1}{2}$ |
| $2\frac{1}{4}$ | $3\frac{3}{8}$ | $1\frac{1}{2}$ | $3\frac{3}{8}$ | $1\frac{11}{16}$ |
| $2\frac{1}{2}$ | $3\frac{1}{2}$ | $1\frac{23}{32}$ | $3\frac{1}{2}$ | $1\frac{3}{4}$ |
| $2\frac{3}{4}$ | $4\frac{1}{8}$ | $1\frac{53}{64}$ | $4\frac{1}{8}$ | $2\frac{1}{16}$ |
| 3 | $4\frac{1}{2}$ | 2 | $4\frac{1}{2}$ | $2\frac{1}{4}$ |

Width across flats = $1\frac{1}{4}D$ to nearest $\frac{1}{16}$.
Height = $\frac{1}{2}D$.

Width across flats for $\frac{1}{4}$ - to $\frac{1}{8}$ -inch diameter = $1\frac{1}{4}D + \frac{1}{16}$.
Above $\frac{1}{8}$ -inch diameter = $1\frac{1}{4}D$.
Height of head = $\frac{1}{2}D$.
Washer face $\frac{1}{16}$ inch thick.

the shank. These proportions are given in equations at the bottom of Tables I and II. The length is always the distance from the tip to the under side of the head, except in the case of stud and flat-head bolts where it is the over-all length. The square and hexagonal head U. S. Standard bolts are furnished in two grades or classes, either rough and semi-finished, or finished. The dimensions of these bolts are shown in Table I. The dimensions for nuts are shown in Table II.

TABLE II
ROUGH AND SEMI-FINISHED SQUARE AND HEXAGONAL
REGULAR NUTS, ALSO
FINISHED SQUARE AND HEXAGONAL REGULAR NUTS

| Diameter of Bolt | Width across Flats | Height | Diameter of Bolt | Width across Flats | Height |
|------------------------|--------------------------|----------------|------------------------|--------------------------|-----------------|
| $\frac{1}{4}$ | $\frac{7}{16}$ | $\frac{7}{32}$ | 1 | $1\frac{1}{2}$ | $\frac{7}{8}$ |
| $\frac{5}{16}$ | $\frac{9}{16}$ | $\frac{7}{16}$ | $1\frac{1}{8}$ | $1\frac{11}{16}$ | 1 |
| $\frac{3}{8}$ | $\frac{5}{8}$ | $\frac{3}{4}$ | $1\frac{1}{4}$ | $1\frac{7}{8}$ | $1\frac{3}{8}$ |
| $\frac{7}{16}$ | $\frac{2}{3}$ | $\frac{3}{8}$ | $1\frac{1}{2}$ | $2\frac{1}{4}$ | $1\frac{5}{16}$ |
| $\frac{1}{2}$ | $1\frac{1}{8}$ | $\frac{7}{16}$ | $1\frac{3}{4}$ | $2\frac{5}{8}$ | $1\frac{1}{2}$ |
| $\frac{9}{16}$ | $\frac{7}{8}$ | $\frac{1}{2}$ | 2 | 3 | $1\frac{3}{4}$ |
| $\frac{5}{8}$ | 1 | $\frac{3}{4}$ | $2\frac{1}{4}$ | $3\frac{1}{8}$ | $1\frac{3}{4}$ |
| $\frac{3}{4}$ | $1\frac{1}{4}$ | $\frac{7}{8}$ | $2\frac{1}{2}$ | $3\frac{1}{2}$ | $2\frac{1}{16}$ |
| $\frac{7}{8}$ | $1\frac{5}{16}$ | $\frac{1}{2}$ | $2\frac{3}{4}$ | 4 $\frac{1}{8}$ | $2\frac{1}{2}$ |
| | | | 3 | 4 $\frac{1}{2}$ | $2\frac{3}{8}$ |

Width across flats, for $\frac{1}{4}$ to $\frac{1}{8}$ -inch diameter = $1\frac{1}{2}D + \frac{1}{16}$ inch.

Above $\frac{1}{8}$ -inch diameter = $1\frac{1}{2}D$.

Thickness of nut = $\frac{1}{2}D$.

Washer face $\frac{1}{16}$ inch thick.

The threads on standard bolts are American National coarse threads; and for standard bolts the length of the threaded portion is equal to approximately three times the diameter of the bolt, except on stove bolts, which are threaded nearly the full length of the shank. Stud bolts also have threaded lengths to suit the conditions of use.

HOW TO DRAW BOLTS AND NUTS

The threads on bolts are represented in exactly the same way as threaded parts discussed in Unit XXIII. Both large- and small-scale symbols may be used according to the size of the drawing. The only new problem, therefore, is to represent the head.

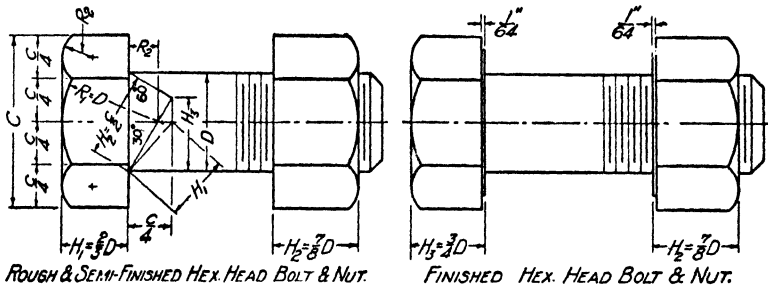

FIG. 2. Method of drawing hexagonal head bolt and nut.

Hexagon-head bolts. Examine Fig. 2 carefully to learn the conventional method of representing hexagon-head bolts and nuts. Notice that the bolt and nut are alike except for the thickness. Make thickness of each as shown. A 30-degree

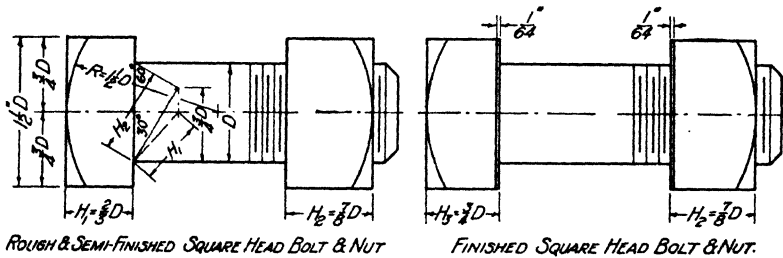

FIG. 3. Method of drawing square-head bolt and nut.

conical chamfer is used on both hexagon and square-head bolts, hence the curve in the side faces is really an hyperbola. In drawing, however, make it an arc of a circle. Figure 2 shows the method for locating the centers of these circular arcs and gives the length of the radii. This is the standard adopted by the American Standards Association. When two

side views of the hexagon head or nut occur in a drawing make both views show three faces as in Fig. 2. Although this is a violation of the principles of projection it makes for clarity, since a hexagon is indicated in any view the workman may look at. It cannot mean an octagon since no such bolt is made.

Square-head bolts. Draw a square-head bolt as shown in Fig. 3. Always turn the side view so that it shows but one

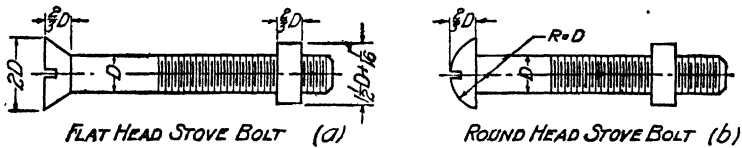

FIG. 4. Method of drawing stove bolts.

face. This will again make both side views alike if two views are made; this time, however, the views are in accordance with the principles of projection. Locate the centers of the arcs as shown in Fig. 3.

Stove bolts. Represent stove bolts as shown in Fig. 4. The proportions shown are for drawing only and do not represent the actual dimensions of the bolts and nuts.

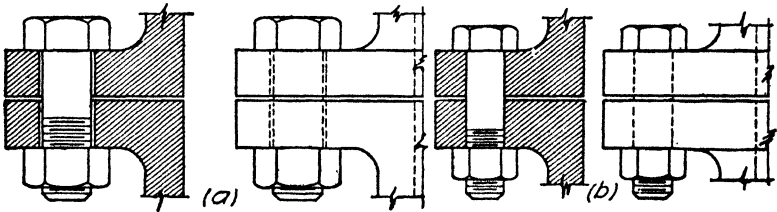

FIG. 5. Representing bolts in holes.

Bolt holes, through which bolts must pass, must be from $\frac{1}{32}$ to $\frac{1}{16}$ larger in diameter than the bolt. When the bolt is shown in a hole, draw either one or two lines depending upon the scale of the drawing. In very small-scale drawings use one line. See Fig. 5b. Where two lines are used, show a thin white space between them. See Fig. 5a.

How to specify bolts. Specify bolts by notes on the drawings. This specification is sometimes placed in the bill of

materials, and the bolt may not be drawn. Always give in the specification the kind of bolt, the diameter and the length. With these things known, all other dimensions are standard. Thus, one might order 20- $\frac{1}{2}$ "x2 $\frac{1}{4}$ " Hex. Fin. Bolt; or 15- $\frac{1}{4}$ "x1 $\frac{1}{4}$ " Flat Hd. Stove Bolts.

QUESTIONS

1. Name four common types of bolts.
2. In what two classes are square- and hexagonal-headed bolts furnished?
3. What is the ratio of the thickness of the head of the semi-finished bolt to the diameter of the shank?
4. What is the ratio of the thickness of the finished square nut to the diameter of the bolt?
5. Show by a sketch what is meant by the chamfer circle, and indicate accurately the size relative to the bolt head.
6. Show by a sketch how to represent a hexagonal bolt head. Show how centers of arcs are located, and give lengths of radii.
7. Show by a sketch how to represent a square bolt head. Show how centers of arcs are located, and give lengths of radii.
8. Show by a sketch how a hexagonal nut is represented when three views must be given.
9. How much of the shank of a Standard bolt is threaded?
10. How much of the shank of a stove bolt is threaded?
11. Show by a sketch what is meant by the length of a standard hexagonal-headed bolt.
12. What information must be given in ordering bolts?
13. For ordinary work, how much larger than the bolt must be the hole through which a bolt is to pass?

PROBLEMS

Lay out the standard border line and title space; then divide the sheet into four equal rectangles by a horizontal and a vertical line. In each space draw one of the bolts specified below. Draw the bolts in a horizontal position, and under each one letter neatly the proper specifications for it.

1. Draw a $\frac{3}{4}$ "x3" rough hexagonal bolt and nut.
2. Draw a $\frac{3}{8}$ "x2 $\frac{1}{2}$ " semi-finished square head bolt and nut.
3. Draw a $\frac{1}{2}$ " stud bolt 3 $\frac{1}{2}$ " long, thread 1 $\frac{1}{4}$ " on each end.
4. Draw a $\frac{3}{8}$ "x2" round-headed stove bolt with square nut.
5. Draw a $\frac{1}{4}$ "x1 $\frac{1}{2}$ " flat-headed stove bolt with square nut.
6. Draw a $\frac{1}{2}$ "x3" finished hexagonal-head bolt and nut.
7. Draw a $\frac{1}{4}$ "x3" finished square-headed bolt and nut.
8. Draw a 1" stud bolt 3" long, threaded 1 $\frac{1}{4}$ " on each end.

UNIT XXV

HALF AND FULL SECTIONAL VIEWS

PURPOSE OF UNIT XXV

It is the purpose of this unit to explain the principles of making sectional views and the methods of making half and full sections.

WHAT YOU SHOULD KNOW ABOUT SECTIONING

Need for sectional views. Many common objects of everyday use have interior construction which cannot be seen

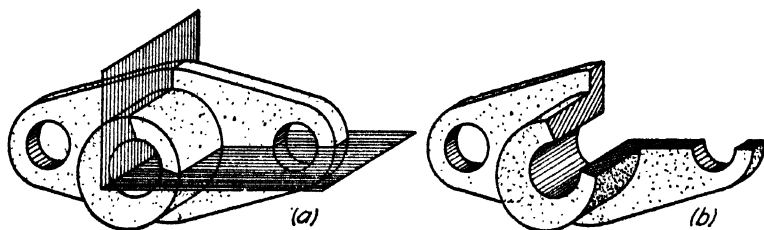

FIG. 1. Method of passing cutting planes.

from the outside. If only the methods thus far discussed are used, these invisible parts have to be represented by dash lines. As the number of these lines increases, the clarity of the drawing rapidly decreases. In many cases it is quite possible to interpret the meaning of the drawing, but an undue amount of effort is required.

To meet this situation a method called sectioning has been devised whereby invisible portions or peculiar contours of objects may be clearly revealed. This method consists of passing imaginary cutting planes through the object and removing a portion, thus representing the hidden part which it is desired to show.

The example, Fig. 1 (a), shows an object and the cutting planes; Fig. 1 (b) shows the same object with the upper

right quarter removed. In order to distinguish the solid material of the object from the open spaces, the material is shaded by diagonal lines called *cross-hatching*, as represented in the pictorial sketch of Fig. 1 (b). This same method is also employed in orthographic views as shown in Fig. 2, where the object in Fig. 1 is represented with the customary two views.

As will be noted in this drawing, when a portion of the object is removed in one view, this does not affect the other views of the object at all. The remaining views are always drawn just as though the entire object were there. This must

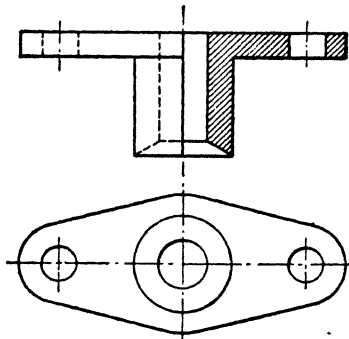

FIG. 2. Half-sectioned orthographic view.

be done; otherwise the impression conveyed would be that the object had this part missing.

When the imaginary cutting planes are passed along axes of symmetry, it is not necessary to indicate on the other views where the cutting plane was passed, since this is quite clear from the drawing itself. This is seen to be true in Figs. 2 and 4.

Half sections. In Figs. 1 and 2, one-fourth of the object was imagined cut away, which causes one-half of the top view to be shown in section. Drawings of this kind are referred to as half sections.

It will be noted in Fig. 2 and elsewhere in this book, except in Fig. 4, Unit XI, that a solid line is used to separate the

portion of the view in section from that in elevation. Although the American Standards Association indicates the use

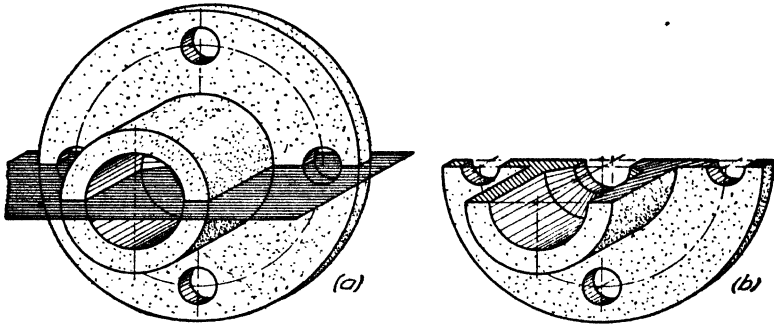

FIG. 3. Method of passing cutting plane.

of a center line for this purpose, the surveys made in 1932 and 1940 indicate that only 38 per cent (1932) and 26 per cent (1940) follow this practise. The solid line, where metal is

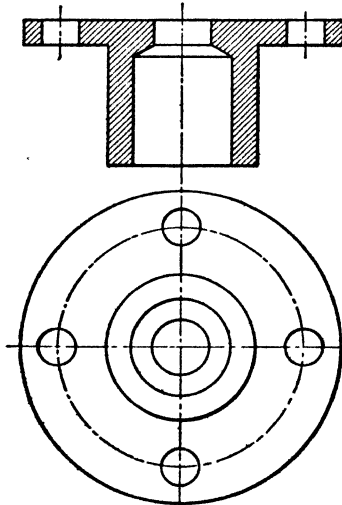

FIG. 4. Full-sectioned orthographic view.

cut, seems to be the best practise. Compare Fig. 5, Unit XI, Fig. 2 in this unit and Fig. 1 in Unit XXVII for clarity of meaning, which is the ultimate standard in drawing practise.

Full sections. In Figs. 3 and 4, it is imagined that the entire object has been cut in two and the top portion re-

moved, thus causing the whole top view to be sectioned. Such a drawing is said to be full sectioned.

Invisible lines in sectional views. Even though a drawing is sectioned, there often remain edges which lie behind the sectioned part and which, according to the rules of projection, should be shown as invisible lines. The edges so represented are usually clearly shown in the other parts of the drawing, hence nothing is gained by drawing invisible lines across the section. Moreover, these hidden lines, though adding nothing to the drawing in clearness, detract from its appearance and are difficult to draw without causing the ink to spread. They are, therefore, always omitted from the sectioned part of the drawing, unless they are absolutely necessary for a correct interpretation.

When to make sectional views. The question frequently arises as to when a sectional view of an object should be made. No fixed rule can be laid down. But it may be stated that a sectional view should always be made if the drawing cannot be interpreted without it. Also, one should be made if, by so doing, the drawing is thereby made easier to read and understand.

The half-sectional view is usually to be preferred in symmetrical objects since it shows both the inside and outside of the object, whereas the full section shows chiefly the inside. Sometimes, as in the case of gear wheels, when the outside form is well known, a full section is advantageous in that it saves time in drawing.

HOW TO MAKE HALF- AND FULL-SECTIONED VIEWS

Make first in light, full outline the necessary two or three orthographic views. Select for sectioning the view which will best reveal the shape of the object. Decide upon whether a half or full section is most suitable for this purpose. If a full section is to be used, draw in the outline as though the object had actually been cut in two and the nearer part had been removed. If a half section is to be made, draw a solid line on the axis of symmetry and draw one side to represent the object as it actually is, and then make the

other side as though one-fourth of the object nearest you had been removed.

Direction of cross-hatching. In order to distinguish the solid material from open spaces, draw inclined lines uniformly spaced across the area representing the solid material. These lines should always be at an angle with the outlines of the object, since they might be confused with the outlines if they were drawn parallel thereto. The cross-hatching lines should have the same slope wherever the same solid part is cut. Thus in Fig. 4, there are four separate cross-hatched areas, but all of them represent the same piece and hence the slope and spacing are the same throughout.

Make the cross-hatching lines of the same weight as dimension lines and space them uniformly throughout the drawing. For the average shop drawing, this spacing should be from $\frac{1}{4}$ to $\frac{1}{8}$ inch. For large drawings the spacing should be increased.

Uniformity of spacing is attained simply by practise and careful work in the usual shop drawing. For very exacting work a special instrument called a section-liner may be used.

QUESTIONS

1. What is meant by a sectional view?
2. What is meant by a half section?
3. What is meant by a full section?
4. Why are sectional views used?
5. How does the draftsman determine when to make a sectional view?
6. When one view of an object is sectioned, what change, if any, does this make in the other views?
7. When half and full sections are made, where is the imaginary cutting plane passed?
8. When the cutting plane is passed along an axis of symmetry, is it necessary to indicate this fact?
9. Is it customary to show hidden lines in a sectional view?
10. What is the objection to showing hidden lines in a sectional view?
11. Should cross-hatching lines be drawn inclined or parallel to the outline of the object? Why?
12. How heavy should cross-hatching lines be made in comparison with other types of lines?

13. What is the proper spacing of cross-hatching lines for the ordinary small shop drawing?

PROBLEMS

Lay out the standard border line and title space, then draw the object assigned from the following group.

Make the sectional view as specified for the particular object assigned.

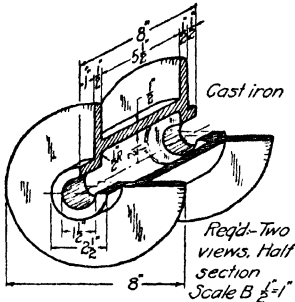

FIG. 5. Double-webbed drum.

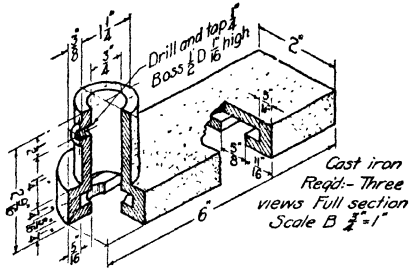

FIG. 6. Tool rest support.

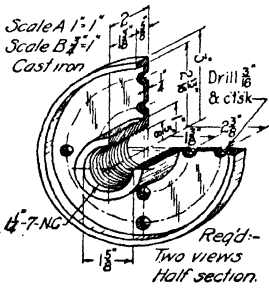

FIG. 7. Face plate.

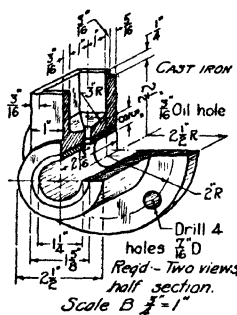

FIG. 8. Box end bearing.

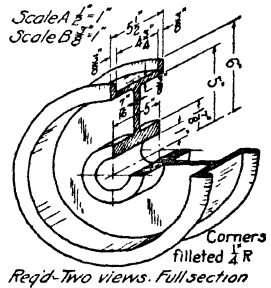

FIG. 9. Single-webbed drum.

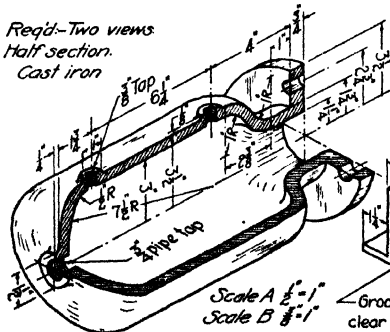

FIG. 10. Drip pocket.

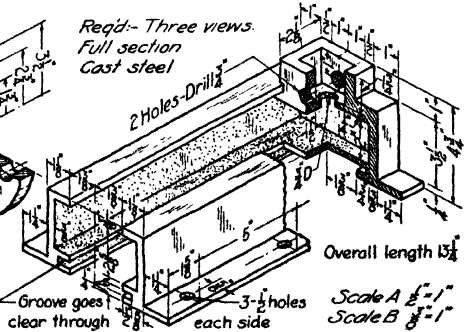

FIG. 11. Bearing take-up body.

UNIT XXVI

REVOLVED, REMOVED AND OTHER TYPES OF SECTIONAL VIEWS

PURPOSE OF UNIT XXVI

It is the purpose of this unit to show how to distinguish adjacent parts of the same material; how to distinguish different materials, and how to make revolved, removed, offset and broken sections.

WHAT YOU SHOULD KNOW ABOUT SECTIONING

Distinguishing adjacent parts. Drawings of machine parts consisting of more than one piece are often sectioned. Many

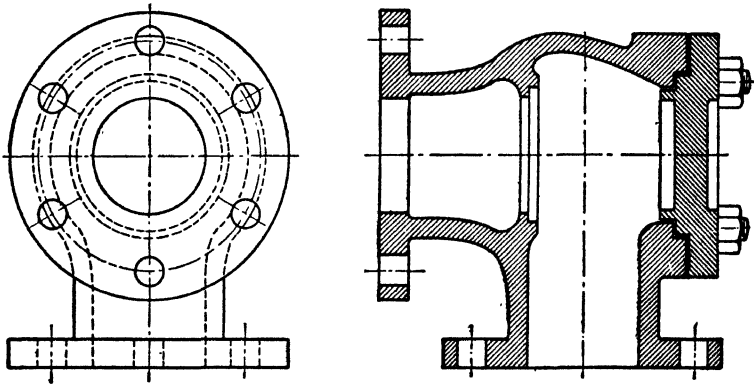

FIG. 1. Sectioning adjacent parts of the same material.

times, such sectional views will show separate pieces of the same material adjacent to each other. In order to make a clear distinction between the various parts of the section, lines are turned at different angles with each other. If there are only two parts, as shown in the sediment separator in Fig. 1, the lines should be at right angles. If three different

parts come together, then other angles may be chosen, as in Fig. 2.

Representing different materials. In order to distinguish between different materials, two different methods are used.

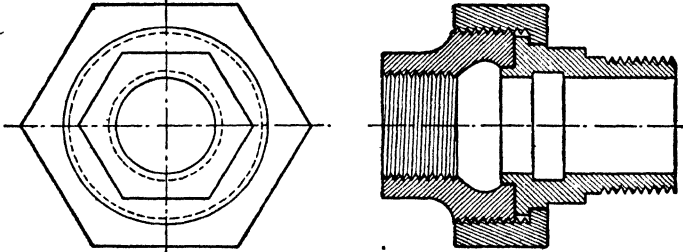

FIG. 2. Sectioning three parts of the same material.

One consists of a system of different types of cross-hatching where each type represents a definite kind of material, as shown in Fig. 3a. The other methods consist of using the same type of cross-hatching throughout the drawing and

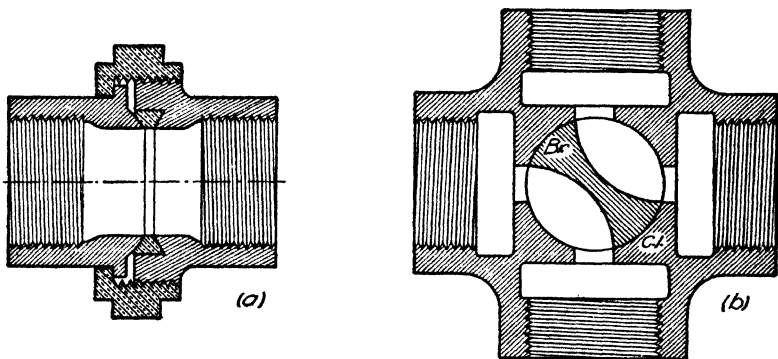

FIG. 3. Cross-hatching for different materials. Two methods.

designating each material by an abbreviation placed within a cleared place in the cross-hatching, as indicated in Fig. 3b.

By means of these devices the draftsman can often save making an extra view.

Revolved or interpolated sections. Besides the half section and full section discussed in the preceding unit, several

other schemes for sectioning are used. One of these is the so-called interpolated section. This is usually applied to long members, either straight or curved, of constant shape in cross-sections, as, for example, the spokes of a wheel, the rim of a wheel, arms and brackets of various kinds of machines. The revolved section is made by passing a cutting plane perpendicular to the plane of the view and revolving it about the center line of the section cut, until it is parallel with the plane of projection, as shown in Fig. 4. Such sections are used in architectural and structural work as well as in machine drawing.

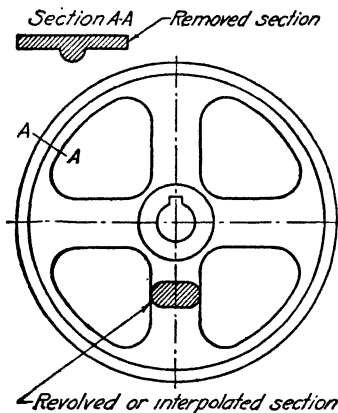

FIG. 4. Revolved and removed sections.

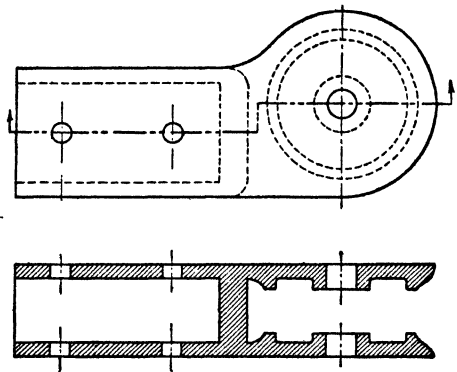

FIG. 5. Offset section.

Removed sections. Sometimes space will not permit of the interpolation of a section as discussed in the last paragraph, yet it may be necessary to show such a section. In a case of this kind a line representing the cutting plane is drawn across that portion of the view which is to be sectioned, with arrows placed at the ends to indicate the direction in which the section is viewed, if this makes any difference. If the direction in which the section is viewed is not important, arrow points are not used, but letters are placed at the ends of the line, as shown in Fig. 4, in order to distinguish this section from others that may be made. The

sectional view itself then is drawn at a clear place upon the sheet and designated by the letters at the ends of the line upon the main view, as Section AA. Such sectional views are called removed sections.

Offset sections. In more complicated machine parts and in buildings it frequently becomes desirable to show sectional views at other places than along an axis of symmetry. The cutting plane must of course always be parallel to the plane of projection, but it may be offset at right angles, to the plane at various points, as indicated in Fig. 5. Such a section is called an offset section. Since it is not upon an

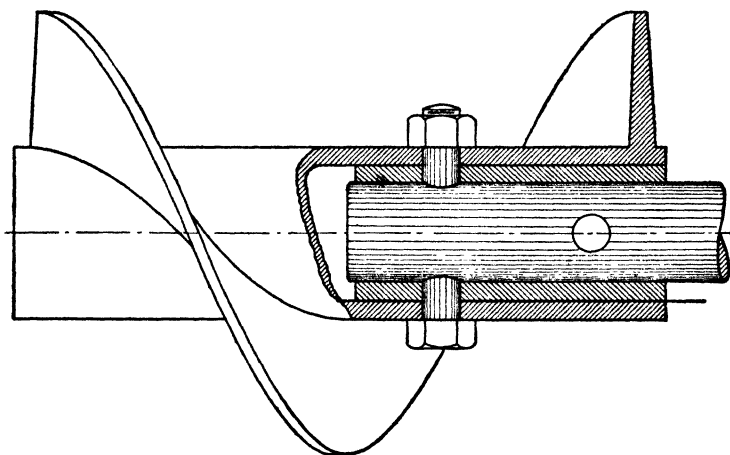

FIG. 6. Broken section.

axis of symmetry, its location would not be clear from the drawing alone; hence, a section of this kind must always have the location clearly designated in one of the views adjacent to the sectioned view. This is done by means of a heavy line consisting of a dash and two dots with arrows at the ends to show the direction of the view, as shown in Fig. 5.

Broken section. In certain types of drawing it is sometimes desirable to show just a part of the interior construction without the formality of a half or full section. This is accomplished by what is called a broken section, in which

a small part in the near side is imagined as removed. The part removed is terminated in a ragged or wavy line as illustrated in Fig. 4, Unit XI and in Fig. 6.

HOW TO MAKE REVOLVED, REMOVED, OFFSET AND BROKEN SECTIONS

The technique of drawing these sections is the same as for any others and requires no special instruction. The decision as to when to make them must be based solely upon the demands of clarity.

QUESTIONS

1. Show by a sketch what is meant by a revolved or interpolated section.
2. What is the purpose of an interpolated section?
3. What is meant by a removed section?
4. How is a removed section tied in to the part which it represents?
5. What is meant by a broken section?
6. When a cutting plane which does not remain throughout upon an axis of symmetry is passed through an object, how is this shown upon the drawing?
7. What is meant by an offset section?
8. When the location of the cutting plane must be shown upon the object, what symbol is used to represent the cutting plane?
9. How are adjacent parts of an object distinguished from one another in a sectional view?
10. How may different materials appearing in a sectional view be distinguished from one another?

PROBLEMS

Lay out the standard border line and title space; then do the problems assigned from the following group, making sectional views as directed in the problem. Do not dimension.

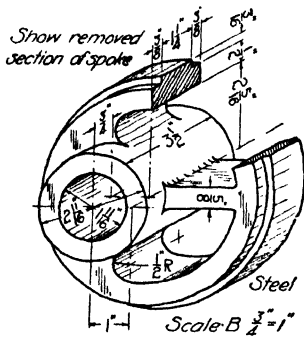

FIG. 12. Eccentric.

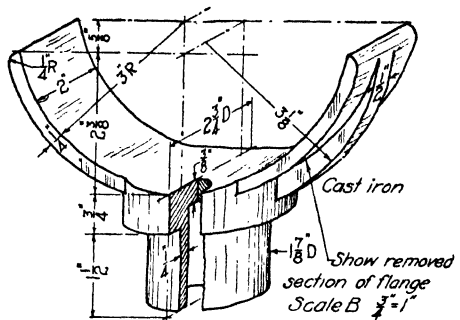

FIG. 13. Pipe support.

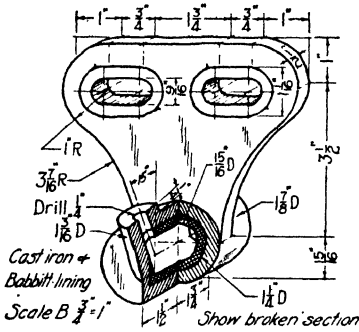

FIG. 14. Return roller bearing.

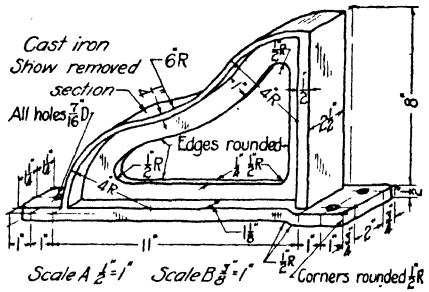

FIG. 15. Wall bracket.

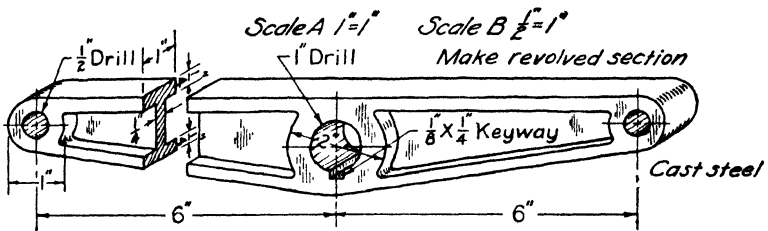

FIG. 16. Gate lever arm.

UNIT XXVII

SECTIONING. STANDARD COMMERCIAL PRACTICE

PURPOSE OF UNIT XXVII

It is the purpose of this unit to indicate the standard commercial practises with regard to sectioning.

WHAT YOU SHOULD KNOW ABOUT COMMERCIAL PRACTISES

The cross-hatching of sectioned views always takes considerable time. In the commercial drafting room time means

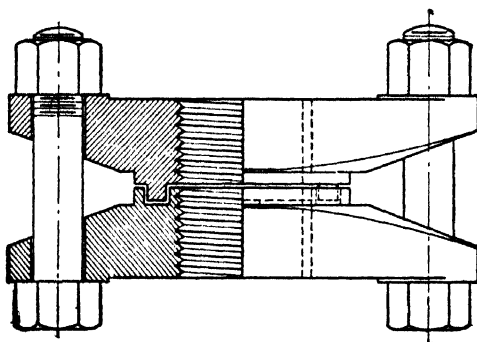

FIG. 1. Bolts in sectional views.

money; hence any cross-hatching which does not serve very definitely to make drawings more easily interpreted is eliminated.

Solid cylinders and shafts. When the section-cutting plane passes through solid cylindrical shafts, bolts and screws, these objects are not sectioned but are left just as though the plane had not cut them. Since they are solid inside, nothing would be gained in explaining the meaning of the drawing, and considerable time would be required to cross-hatch these parts; hence, they are never cross-hatched. This practise is illustrated in Fig. 1 and also in Fig. 6 of Unit XXVI.

Spokes of wheels. Another common case in which a departure from the strict theory of projection makes the drawing clearer, and also saves time, occurs when the cutting plane passes through the spokes of wheels. If the hub, spokes and rim were all cross-hatched this view would give the impression that the hub and rim were connected by a solid web. Hence, it is the standard practise to section the rims and hubs but not the spokes, as shown in Fig. 2. This view now cannot be misinterpreted. A revolved section through the spoke also adds to the clarity of the drawing.

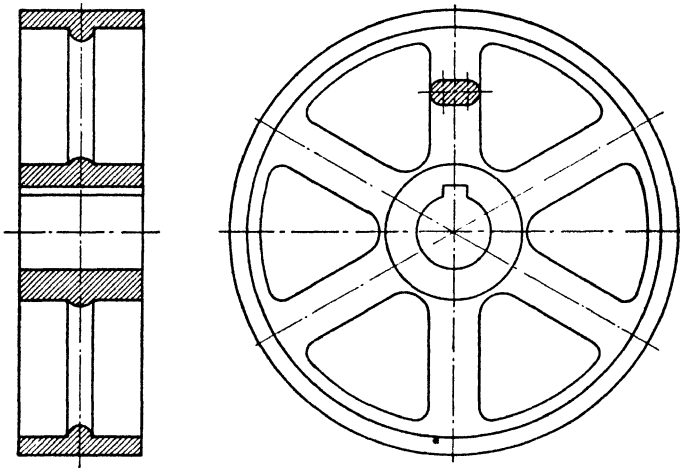

FIG. 2. Spokes in sectional views.

Thin webs. Occasionally a section plane passes through a thin web parallel to its greatest dimensions. Here, again, although the web is actually cut by the section plane, the drawing is much clearer if the web is not cross-hatched. This is the standard practise, as illustrated in Fig. 3. In this case if the webs are cross-hatched the sectional view would give the impression that the valve had no flange at the top.

Unsymmetrical parts. In making drawings of objects which are not symmetrical about two axes, as, for example, a hand wheel with an odd number of spokes, the sectional views are made as though there were an even number of spokes, as shown in Fig. 4a, and not as would be required by the rules

of projection. The other view, of course, shows the correct number of spokes, and the drawing is unmistakable; at the same time it is better appearing and more easily made. This

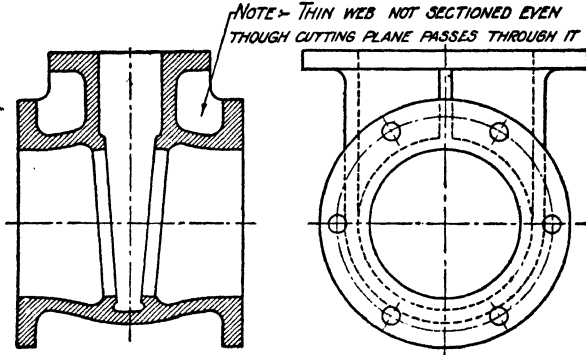

FIG. 3. Thin webs in sectional views.

practise is standard not only for spokes but also for holes and other parts which occur in odd numbers in circular pieces. See Fig. 4b for another example.

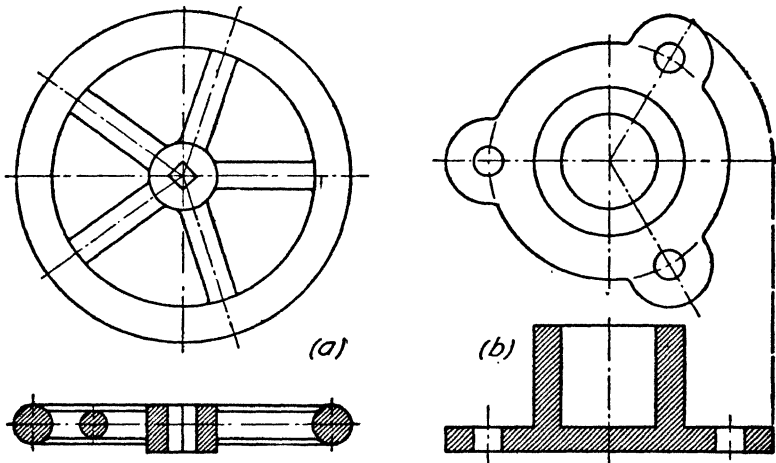

FIG. 4. Odd numbered axes of symmetry in sectional views.

HOW TO MAKE SECTIONS FOR WORKING DRAWINGS

Working drawings, or shop drawings, should always be made in accordance with the best commercial practise, as

explained in the preceding paragraphs. To draw the sections described in this unit no new instructions in methods of drafting are needed.

QUESTIONS

1. If a cutting plane passed through a spoke of a wheel, should the spoke be sectioned?
2. When a cutting plane passes through solid objects such as cylindrical shafts, bolts, screws, etc., are these parts sectioned? Why or why not?
3. If a cutting plane passes through a thin web of material, is the web sectioned? Why or why not?
4. If an odd number of spokes, holes or webs occurs in an object, which is shown sectioned, what is the standard practise in representing these parts?
5. What defense can you offer for the violation of the principles of projection referred to in question 4?

PROBLEMS

Lay out the standard border line and title space; then do the problem assigned from the following group.

Make enough views to describe clearly the shape of the object, including sectional views made in accordance with standard practise. Do not dimension the drawing. You need not necessarily make the same section as shown in the pictorial views. Use your own knowledge and judgment as to what views and sections will best show the object.

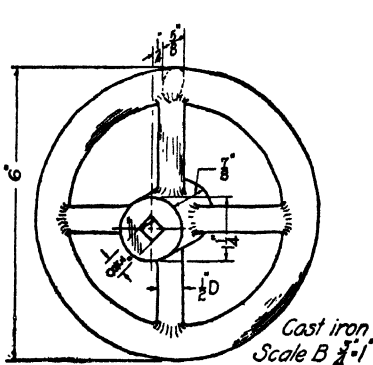

FIG. 5. Handwheel.

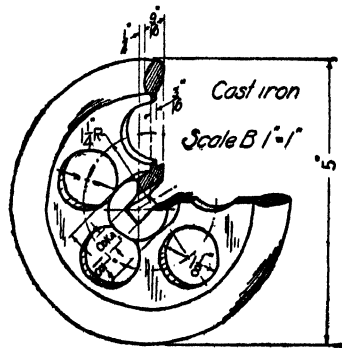

FIG. 6. Handwheel.

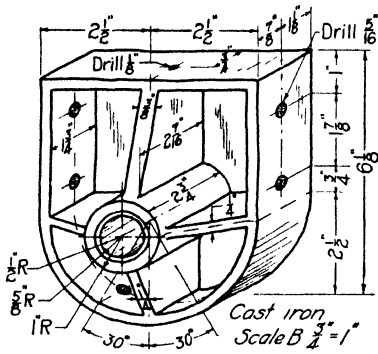

FIG. 7. Box end bearing.

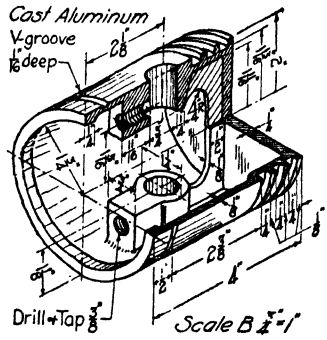

FIG. 8. Piston.

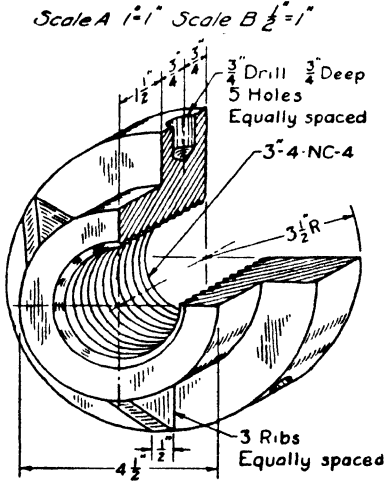

FIG. 9. Spacer nut.

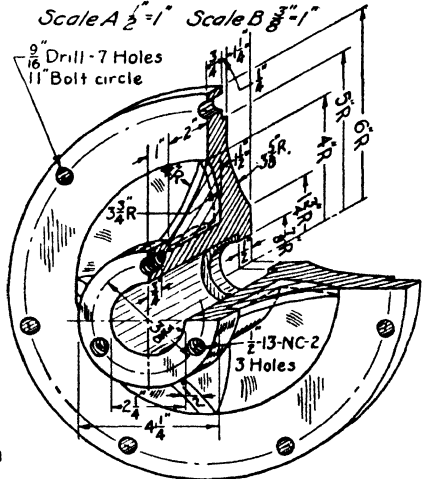

FIG. 10. Cylinder head.

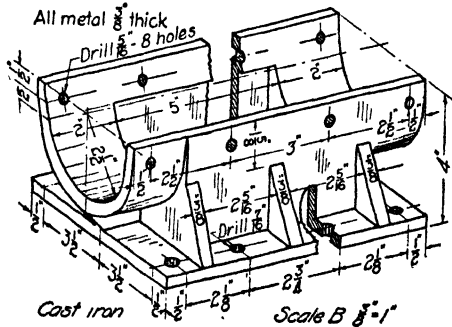

FIG. 11. Discharge gate.

UNIT XXVIII

ORDER OF WORK IN MAKING SHOP DRAWINGS

PURPOSE OF UNIT XXVIII

It is the purpose of this unit to teach the proper order of procedure in making a working drawing or shop drawing.

WHAT YOU SHOULD KNOW ABOUT MAKING SHOP DRAWINGS

Having studied the principles of auxiliary projection, sectioning and dimensioning and the use of shop terms, we are now prepared to face the problem of making working drawings as it comes to the man in the commercial office. It will be recalled that a working drawing consists of an adequate number of correctly made views of an object, completely dimensioned and noted so that the object can be made without further information or calculation.

Order of procedure. With the problem before him the draftsman must learn to attack his work in orderly fashion. To do this he must consider carefully all important factors in his problem before beginning to draw. The following order of procedure is suggested as the best:

1. **Selection of views.** The draftsman's first job is to decide how many views are needed. This will depend mostly upon the nature of the object, but it may also be influenced by the method of manufacture or construction. A very simple illustration will suffice to explain this point. Suppose the object is a model of a truncated right circular cylinder. If it is to be made of wood, properly chosen front and top views will suffice. On the other hand, if it is to be made of sheet metal, the front, top and an auxiliary view, showing the true shape and dimensions of the truncated face and a development of the cylinder, will be required.

Auxiliary views will be chosen upon the basis of true shapes required for dimensioning. Sectional views will be chosen not so much upon the basis of necessity as upon that of clarity of meaning and ease of interpretation.

2. **Choice of scale.** After having decided upon the number of views, the choice of a scale follows next in order. This involves two things, namely, the type or kind of scale and the size of scale.

Type of scale. The type of scales, whether architect's or engineer's, should be decided in accordance with the kind

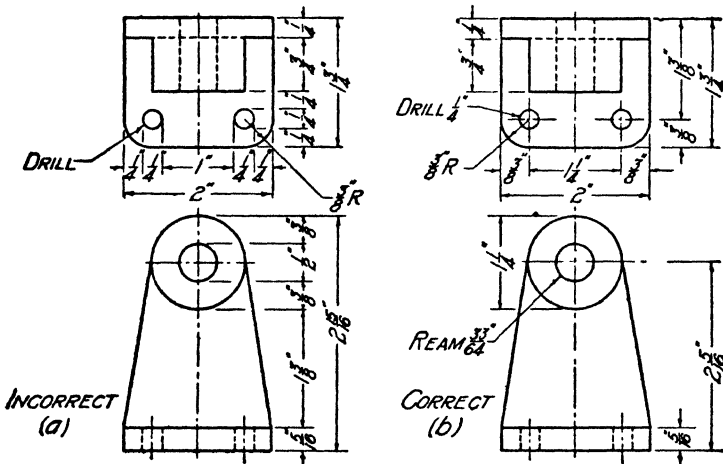

FIG. 1. Correct and incorrect methods of dimensioning.

of object being represented and the units of measure used by those making the object. For buildings, bridges and other objects which are measured in feet and inches the architect's scale is used; for machine parts and other objects which are measured in inches and fractions of an inch, such as 64ths, 32nds, 16ths, 8ths, etc., the mechanical engineer's scale is used; and for maps the civil engineer's scale.

Size of scale. The size of the scale will be determined, for the most part, by the relative size of the paper and the object. The draftsman will usually have several sizes of paper to choose from, and he should select one large enough

which is the center of the hole, hence the workman cannot use the distance between the edges of the holes. Again, in Fig. 2, the cylindrical parts must be turned in a lathe. The sizes are measured with a caliper, which gives the diameter, hence the series of dimensions giving the steps out from one cylinder to the next are quite useless, whereas the diameters which the workman needs are missing and can be obtained only by adding up these details, which, of course, is not the workman's job. Figure 3 shows a correct method of dimensioning this pulley. These two illustrations will

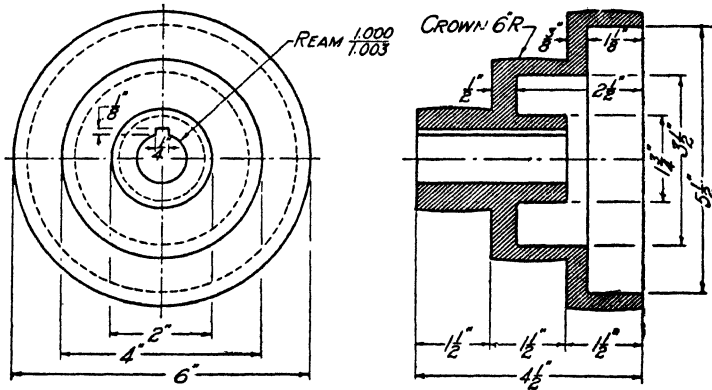

FIG. 3. Correct dimensioning for cylindrical parts.

suffice to show the need of taking the workman's point of view while dimensioning.

5. **Lettering.** After the dimensioning has been completed, notes must be added giving shop processes and, where necessary, materials, finish, etc. Then letter the title of the drawing.

Summary. To make a working drawing, proceed in this order:

1. Determine number and kind of views.
2. Select scale.
3. Make all views.
4. Dimension drawing.
5. Add notes, legend and title.

QUESTIONS

1. What is the first problem of the draftsman when presented with the task of making a working drawing of some object?
2. What decides the type of scale he will employ? Give an example.
3. What decides the size of the scale, whether large or small?
4. In determining the size of scale what must he make allowance for besides the views of the object?
5. In commercial practise what factor beside the object influences the number of views to be made?
6. Upon what basis will an auxiliary view be made or omitted?
7. What will determine the making or omission of a sectional view?
8. How should holes be dimensioned?
9. How should concentric cylinders be dimensioned?
10. In general, what point of view should the draftsman adopt while dimensioning his drawing?

PROBLEMS

Lay out the standard border line and title space; then make a working drawing of one of the objects assigned from the following group.

First make a freehand sketch showing the number, kind and arrangement of views you plan to use. Then choose a scale which will fit the drawing to your standard size of paper, if it differs from the standard sizes in this text. Submit these to your instructor for approval. Make the changes or corrections suggested, then proceed to make the working drawing with instruments.

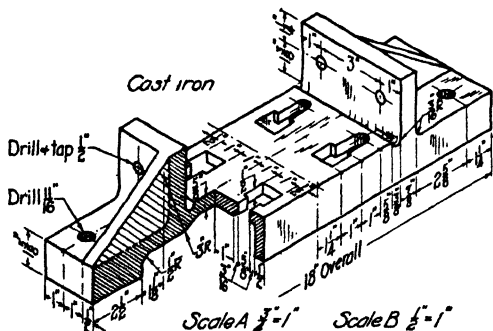

FIG. 4. Pillow block base.

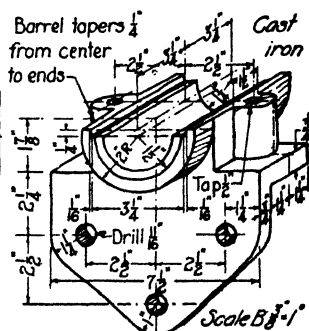

FIG. 5. Cap bearing.

UNIT XXIX

MAP DRAWING

PURPOSE OF UNIT XXIX

It is the purpose of this unit to show the characteristics of different kinds of maps, how to read maps and how to draw the simpler varieties.

WHAT YOU SHOULD KNOW ABOUT MAPS

Every school boy or girl has had to make use of maps. The use of maps is now an everyday experience for almost everyone. It is therefore valuable to know something about maps, how to make and read them.

Kinds of maps. Many different kinds of maps could be made of any given area. They would differ from each other in their scale and content, which would be determined chiefly by the purpose they were intended to serve.

Geographic maps. Geographic maps usually cover a rather wide area and show only the principal features of the land such as mountain ranges, important rivers and cities, etc. These are usually found in geography and history textbooks, and since they cover a very large area the scale is usually very small, ranging from several miles to the inch to one hundred miles or more to the inch.

Topographic maps. In general, topographic maps deal with a much smaller area than geographic maps and show much more detail. The scale varies somewhat with the use to be made of the map, but the smallest scale is about 4 miles to the inch. The best examples of such maps, on which are shown all roads and trails and even houses, are those prepared by the United States Geological Survey. Elevations are shown by contour lines, and forests, marshes, etc., are

shown by symbols. These are printed in appropriate colors as described elsewhere in this Unit. Figure 1 is an illustration of this type of map.

Highway maps. This is a type of map which is used every day. These maps may represent one state of the Union or a small group of states, such as the New England states. They show all the cities, towns and villages of a state, together with the principal state and county highway systems. Small highways and lanes are not shown. Besides the highways, they show by symbols the approximate population of the towns, the distance between the principal towns, the location of public parks, monuments and other points of historic interest. Of natural features, only the larger streams and lakes are shown. They are frequently printed in colors and range in scale from 10 to 40 miles to the inch.

City plats. The city plat shows the streets and property lines, size and location of lots and various additions which have been made to the city from time to time. In larger cities in the office of the city engineer there will also be maps showing the location of sewers, water lines and other services which the city may have. Other maps will show political subdivisions such as precincts and wards. The scale of such maps varies a great deal, usually not being smaller than 6 inches to the mile. The larger scales may run from 100 to 400 feet to the inch.

Engineering maps. As the name indicates, such maps are used for engineering work, and they must, therefore, be of rather large scale. The common range runs from $500' = 1''$ up to the architectural scales such as $\frac{1}{8}'' = 1'-0''$. Highway construction maps, railroad maps, maps for lock and dam construction are some of the more common varieties.

Symbols used on maps. Since all maps are of comparatively small scale, almost everything on them must be shown in some conventional way by symbols. Symbols fall into certain natural groups, as discussed in the following paragraphs.

Vegetation symbols. All symbols used on maps have been standardized as to both form and color. A few of the more

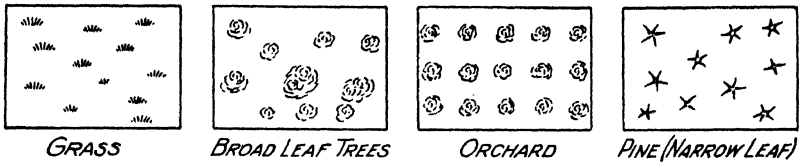

FIG. 2. Vegetation symbols.

common symbols for vegetation are shown in Fig. 2. These are made with green ink.

Hydrographic (water) symbols. A few of the more useful water symbols are shown in Fig. 3. These are always

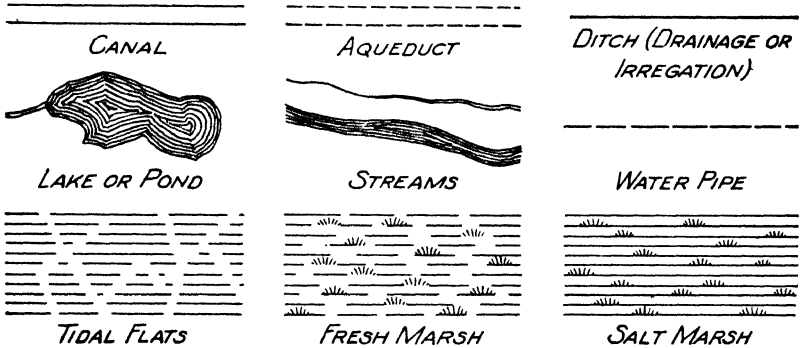

FIG. 3. Water symbols.

drawn in blue ink. On ordinary maps the symbols should be made the same size as shown here.

Works of man. The works of man are shown in black

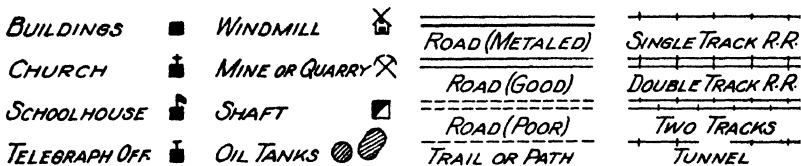

FIG. 4. Symbols for works of man.

ink and include roads, railroads and structures of all descriptions. A few symbols* are shown in Fig. 4.

* For more complete sets of symbols see "Engineering Drawing" by Jordan and Hoelscher, John Wiley & Sons, New York.

Relief. Symbols which show the nature of the ground surface are called relief symbols. These are drawn in brown

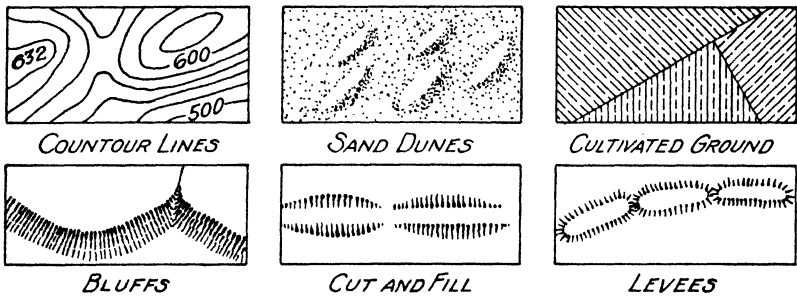

FIG. 5. Relief symbols.

ink. Figure 5 represents a few symbols of this type. When it is necessary to give only a general idea of elevations, such as the locations of mountain ranges on geographic maps, a system of symbols called hachures, illustrated in Fig. 6, are used. When exact information concerning the elevation of the land is necessary contour lines are employed. By the

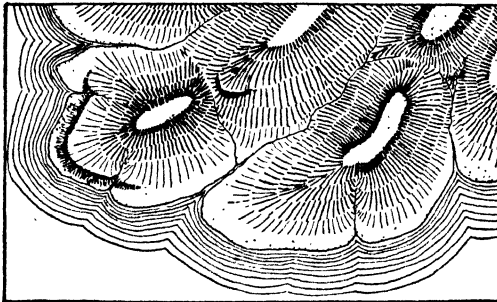

FIG. 6. Hachures.

term elevation is meant the height in feet above mean sea level.

Contour lines. By a system of symbols called contour lines the elevation of the earth's surface can be shown rather accurately, particularly on large scale maps. A contour line is an imaginary line passing through all points of the same elevation. The water line or shore line of a still body of water

would be a contour line. If the water level could be raised one foot, the new shore line would represent another contour line. See Fig. 7. The difference in elevation of contour

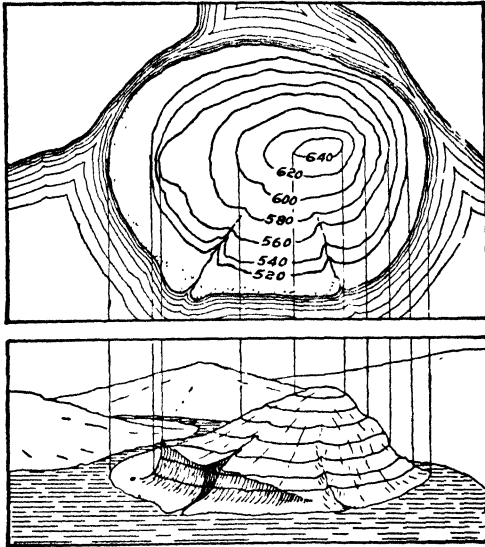

FIG. 7. Contours.

lines is called the contour interval. In Fig. 7 above it would be a 20-foot interval. Contour lines are drawn at various intervals from 1 foot to 20 feet, depending on the scale and the purpose of the map.

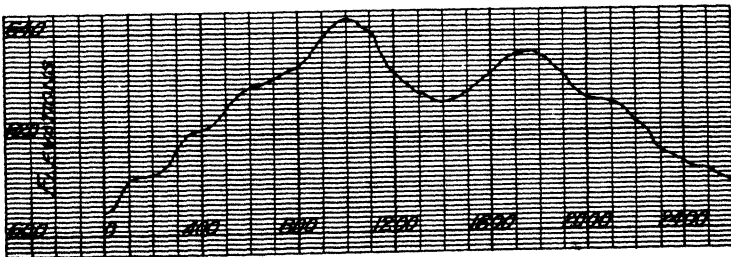

FIG. 8. Profile.

Profiles. When railroads, highways, sewer lines, etc., are to be constructed, it is necessary to know the elevation of the ground along the proposed route. A drawing showing a

line representing such elevations is called a profile. It may be considered essentially a section through the earth's surface without the cross-hatching. Figure 8 represents a profile. Two different scales are used to bring out more clearly the difference in elevation. A large scale is used for vertical distances, which may have a range of 50 to 100 feet, and a small one for horizontal distances, which may run into several miles in length.

HOW TO DRAW A MAP

Maps are drawn either from other maps or from survey notes. The survey notes may take many forms, but we shall

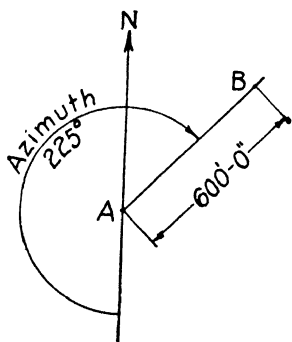

FIG. 9. Azimuth of a line.

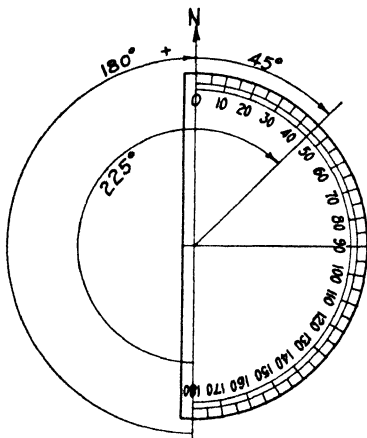

FIG. 10. Plotting an azimuth.

here describe only one type. Any method of surveying consists essentially of locating a series of points or objects with reference to another point called a station. This can be done by measuring the angle which the line from the station to the object makes with some previously established line through the station. If this established line through the station is a north-and-south line, the angle made with it by the line running to the object is called the azimuth of the new line if it is measured clockwise from the south. Some surveyors measure the angle from the north. In this unit it will be measured from the south.

Hence, point *B*, see Fig. 9, can be located from a station, *A*, by knowing azimuth and distance. The azimuth would be measured in the field with a transit and the distance would be measured with a tape. Along with these measurements made in the field, the surveyor makes sketches of the surveyed area in his notebook. From his notes and sketches the surveyor or his draftsman can plot a map.

In the drafting room these surveying operations are repeated in miniature; the angle, or azimuth, is measured with a protractor and the distance to the observed points is laid out with a scale. The sketches help to complete the map in its smaller details. A set of such notes is given in the problems. See Fig. 18.

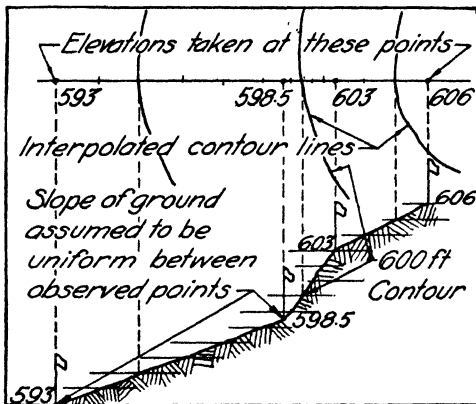

FIG. 11. Interpolating contour lines.

Since the ordinary protractor covers only 180 degrees, when the azimuth is larger it is necessary to subtract 180 degrees from it and lay out the remainder in the proper direction. Thus, if the azimuth of a line is given as $225^{\circ}-0'$, first subtract $180^{\circ}-0'$ from it leaving a remainder of $45^{\circ}-0'$ which would be plotted by laying the protractor on the right-hand side of the line and measuring $45^{\circ}-0'$ from the north or top end of the line. See Fig. 10.

To draw contour lines. Contour lines are established by determining the elevation as well as location of points on

the ground. The location of a point can be determined by azimuth and distance, and then the elevation can be determined with either a level or a transit.

Since it would be very difficult to locate all points in the field exactly on a given contour line of a certain elevation, for example a 605-foot contour, it is customary to get elevations at points where there is a change in slope on the earth's surface and then put in the contour line by interpolation, as illustrated in Fig. 11. If the slope is uniform, as it is as-

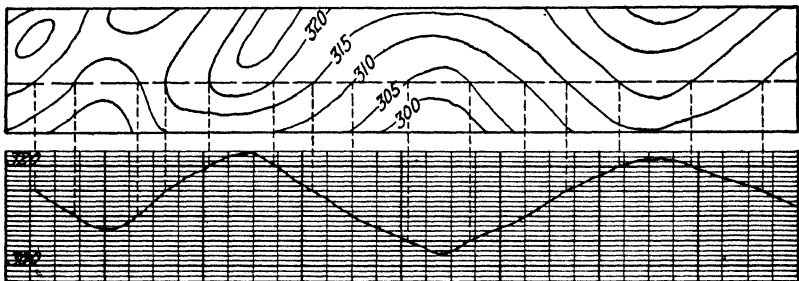

FIG. 12. Profile plotted from contour lines.

sumed to be between observed points, the interpolation is quite simple. Thus in Fig. 11 along a line represented at the top of the figure, observations were taken at elevations 593, 598.5, 603 and 606. The 605-foot contour would lie between 603 and 606. It would be two feet above point 603 or one foot below the 606 point, as shown in the profile in the lower part of the figure where the light horizontal lines represent intervals of one foot in elevation. If these division marks on the profile were projected up to the survey line at the top of the figure, the 605-foot contour would cross the line at a point two-thirds the distance from 603 to 606.

The location of this two-thirds division can be done by estimating or by use of a stretched rubber band on which uniform divisions have been marked in ink in its unstretched condition. Then if we wish to locate the 605 contour, for example, between the two points whose elevations are 603 and 606 we can stretch the band with the finger and thumb so that there are three spaces ($606 - 603 = 3$) on it between

the two points. The 605 contour then is under the second division from the 603 point. This is a convenient device for making rather accurate interpolations quickly. If stretching the band to get three spaces between the plotted points is too great, then some other multiple of three could be used, as for example, 12. Then one would count off eight small units to get the two-thirds point.

The following rules will be helpful in plotting contours.

1. Contours of the same elevation must appear on both sides of a stream or still body of water.

2. A contour line goes upstream, roughly parallel to the stream, before it crosses the stream.

3. A contour line can cross a stream only once.

4. Contour lines themselves never cross. Overhanging cliffs are so rare and the contour interval in country where they would occur is so great that the above rule holds.

5. Contour lines must close, that is, form closed loops, or run off the edge of the map.

Drawing profiles. In practice a profile is made by obtaining the levels at certain intervals along some predetermined line and then plotting these points on profile paper, which is a commercial paper ruled as in Fig. 8. An approximate profile can also be made from a contour map by drawing the proposed line on the map and then measuring distances between contours along this line as indicated in Fig. 12. Ordinarily these distances could not be projected as in Fig. 12. They would then be transferred from the map to the profile with a divider.

Drawing symbols. Making symbols, like lettering, requires practise and a careful study of good examples. All symbols should be made small and delicately. Vegetation symbols such as grass and trees should be spaced irregularly and not in any pattern that will show. The grass symbol should always have its base parallel to the bottom of the sheet. Water lining (see Fig. 3) should be very closely spaced near the shore line and then very gradually opened up in spacing. Your symbols should not be larger than those

shown in the text. Practise first in pencil, then in ink using the proper color. Final work must be done directly in ink since colored inks will not stand much erasure, even with art gum.

Lettering on maps. On engineering maps which are used for construction purposes either vertical or slant single-stroke Gothic or Reinhardt letters may be used. On maps of a more formal character, the standards of the United States Geographic Board shown in Figs. 13 to 17 should be used.

A B C D E F G H I J K
L M N O P Q R S T U
V W X Y Z

States, Counties, Townships, Capitals and Principal Cities (all capital letters)

a b c d e f g h i j k l m n o p q r s t u v w x y z

Towns and Villages (with capital initials)

FIG. 13. Map alphabets, civil divisions.

A B C D E F G H I J K
L M N O P Q R S T U
V W X Y Z

Lakes, Rivers and Bays (all capital letters)

a b c d e f g h i j k l m o p q r s t u v w x y z

Creeks, Brooks, Springs, Small Lakes, Ponds, Marshes and Glaciers (with capital initials)

FIG. 14. Map alphabets, hydrography.

ABCDEFGHIJKLMNO
PQRSTUVWXYZ

Mountains, Plateaus, Lines of Cliffs and Canyons (all capital letters)

abcdefghijklmnopqrstuvwxy^z

Peaks, Small Valleys, Canyons, Islands and Points (with capital initials)

FIG. 15. Map alphabets, hysography.

ABCDEFGHIJKLMN**OPQR****STUV****WXYZ**
1234567890

Railroads, Tunnels, Bridges, Ferries, Wagon-roads, Trails, Fords and Dams (capitals only)

FIG. 16. Map alphabets, public works and contour numbers.

ABCDEFGHIJKLMN**OPQR****STUV**
WXYZ

a'bcdefghijklmnopqr**stuv**wxy^z

(with capital initials)

FIG. 17. Map alphabets, marginal lettering.

QUESTIONS

Note: Each student should have a highway map to answer questions 1 to 13.

1. How are main United States highways distinguished from state routes?
2. How can you distinguish between state and county roads?
3. How can you tell which roads are hard surfaced?
4. How can one tell the approximate size of towns along a highway?
5. How can you find the distance between towns, within the same county, for example?
6. How can you find a town whose location you do not know on the map?
7. How are points of interest, such as state parks, etc., indicated on the map?
8. How are county boundaries shown?

9. Are railroads shown? If so, what symbol is used?
10. How are the smaller streams shown?
11. Do road maps show all the turns in a road? If not, why?
12. If the distance between two towns is not given, how can it be determined?
13. How can you find the scale of a map?
14. What type of map ordinarily covers the greatest area?
15. Where are geographic maps most commonly found?
16. What things are found represented on geographic maps?
17. What do city plats show?
18. What do topographic maps show?
19. Name some common types of engineering maps.
20. Why are symbols used on maps?
21. What color is used for vegetation symbols?
22. What kind of symbols are drawn in black?
23. What is a contour line?
24. What is meant by a profile?
25. What information is given by a profile?
26. Why are two scales used on a profile?
27. What is meant by the azimuth of a line?
28. What is meant by the elevation of any point on the earth's surface?
29. What is the elevation of your town?

PROBLEMS

1. Divide your drawing sheet (small size) into twelve equal rectangles and then draw in twelve symbols assigned by your instructor.

2. Draw the standard border line, omitting the title strip, on an $8\frac{1}{2} \times 11$ " sheet. See sheet *C*, Fig. 15, p. 13. Then from the notes and sketch in Fig. 18 of this unit, which represents a surveyor's notebook, make the map of the area surveyed. Plot first the notes on the left-hand side, then by reference to the sketch complete the map. The notes read up the page. Items above station 1, including station 2, are plotted from station 1. Those above 2, including station 3, are plotted from station 2 and so on. Plot station 1 from station 3, thus closing the circuit, or traverse as the surveyor calls it, and make a check on the accuracy of your work. It is well first to plot the three stations with the check on station 1, and then fill in the details afterwards. Scale $400' = 1''$. Use a 40 engineer's scale. For example, measure to scale 100 feet from the right border and 900 feet from the lower border to plot station 1. Through this station draw a long vertical (north-and-south) line above and below the point, also a horizontal (east-and-west) line. Lay the protractor over the point so that the 180-degree lines and the 90-degree lines coincide accurately with those you have just drawn. Then to plot station 2 measure off an angle of

142 degrees from the south and draw the line. On this line measure 2530 feet, which locates station 2. All points between stations 1 and 2 are plotted in the same way.

Through station 2 again draw long vertical and horizontal lines and proceed as before with the points above station 2, including the plotting of station 3 and so on until the plotting is completed.

3. Same as Problem 2. Use notes and sketch in Fig. 20.

4. On an $8\frac{1}{2} \times 11$ sheet, with border line as in sheet C, Fig. 15, p. 13, make a contour map from the data shown in Fig. 19 of this unit. The elevations are given on a rectangular grid to save you time. A few contours have been suggested to aid you in starting properly. Estimate the location of contours along the lines between points with the aid of a marked rubber band. Sketch your contours in pencil, then have them checked by your instructor before inking. Number each contour (see Fig. 12). Remember that the land slopes toward the water courses, and contours will follow the streams in a general way. (NOTE: This contour map may be drawn on the map of Problem 2, thus giving a complete topographic map. The station points marked 1, 2 and 3 correspond to those of Problem 2.) Scale $400' = 1''$.

5. Same as Problem 4. Use Fig. 21. (NOTE: This contour map may be drawn on the map of Problem 3, thus giving a complete topographic map. See instructions under Problem 4.)

6. Make a profile from the contour map of Problem 4 along the east-and-west section line. Vertical scale $1'' = 10'-0''$; horizontal scale $1' = 400'$.

7. Make a profile from the contour map of Problem 4 along the railroad line. Vertical scale $1'' = 10'-0''$; horizontal scale $1'' = 400'$.

8. Same as Problem 6. Use contour map of Problem 5.

9. Same as Problem 7. Use contour map of Problem 5.

10. Make a profile from either contour map above along some line to be designated by your instructor.

Note: Instructors may obtain a copy of each map in Problems 2 and 3 above by addressing the authors on school stationery.

| Station | Azimuth | Distance |
|--|----------|----------|
| O1 (check back for L & distance) | 266° 0' | 3485'-0" |
| West bank of stream | 325° 30' | 940'-0" |
| P.C. on highway & (Rad 1000) | 265° 30' | 1245'-0" |
| E of 150' highway bridge | 255° 50' | 1020'-0" |
| Southeast corner of barn | 197° 45' | 1245'-0" |
| Southeast corner of house | 189° 30' | 1170'-0" |
| Intersection of highway & s | 171° 50' | 900'-0" |
| Northeast corner of house | 135° 45' | 534'-0" |
| Southwest corner of barn | 108° 45' | 610'-0" |
| O3 | 40° 30' | 2945'-0" |
| Intersection of highway & R.R.s | 91° 50' | 2040'-0" |
| Northeast corner Bldg No.1 | 38° 0' | 810'-0" |
| Southeast corner Bldg No.2 | 30° 30' | 975'-0" |
| P.T. on R.R. switch (Rad 820) | 28° 0' | 836'-0" |
| P.R.C. on R.R. switch | 359° 0' | 635'-0" |
| P.S. on R.R. (Rad 820) | 312° 45' | 815'-0" |
| O2 | 142° 0' | 2530'-0" |
| East bank of stream | 168° 45' | 1700'-0" |
| Intersection of highway & R.R.s | 168° 45' | 1305'-0" |
| E of R.R. bridge (200' span) | 155° 0' | 1510'-0" |
| East bank of stream | 142° 0' | 1250'-0" |
| South bank of stream | 104° 15' | 1430'-0" |
| P.T. on E of highway (Rad 1000) | 104° 15' | 895'-0" |
| O1 Locate Sta. No.1 100 ft from right border line & 900 ft from lower border line. | | |

These notes read up the page

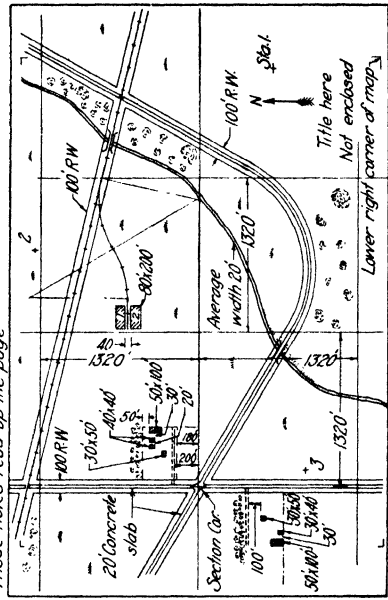

FIG. 18.

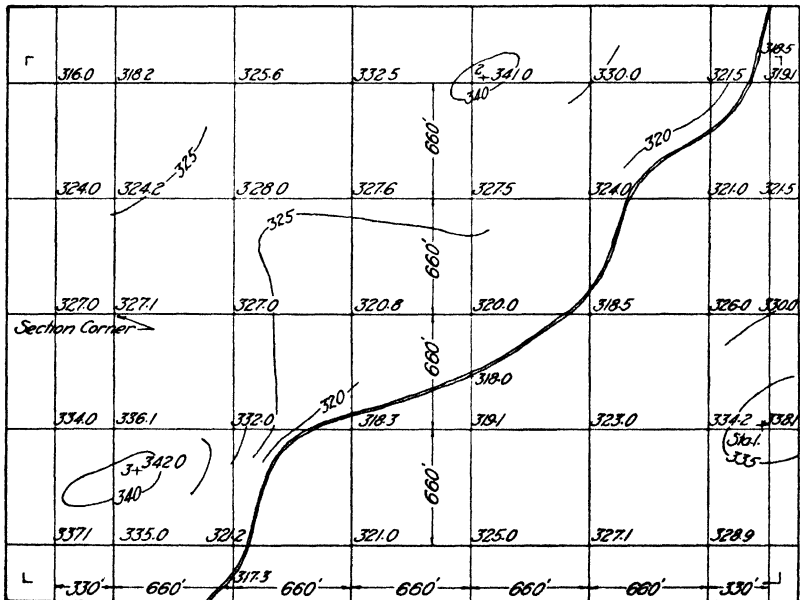

FIG. 19.

| Station | Azimuth | Distance |
|--|------------------|------------|
| O1 (check back \angle & distance) | $91^{\circ}0'$ | $3020'-0"$ |
| Section Corner | $223^{\circ}0'$ | $575'-0"$ |
| P.T. on highway ϵ (1000 Rad) | $192^{\circ}0'$ | $432'-0"$ |
| P.C. on highway ϵ | $110^{\circ}0'$ | $569'-0"$ |
| ϵ of 200' highway bridge | $84^{\circ}0'$ | $900'-0"$ |
| P.T. on highway ϵ | $67^{\circ}30'$ | $1775'-0"$ |
| East bank of stream | $34^{\circ}0'$ | $1051'-0"$ |
| O3 | $348^{\circ}30'$ | $1640'-0"$ |
| Northwest corner of barn | $298^{\circ}30'$ | $1215'-0"$ |
| Northwest corner Bldg No.2 | $310^{\circ}45'$ | $564'-0"$ |
| Southwest corner Bldg No.1 | $322^{\circ}15'$ | $695'-0"$ |
| R.R. ϵ | $110^{\circ}0'$ | $545'-0"$ |
| P.T. on R.R. switch | $70^{\circ}35'$ | $1390'-0"$ |
| P.S. on R.R. switch (200' Rad) | $72^{\circ}05'$ | $2010'-0"$ |
| North bank of stream | $47^{\circ}0'$ | $1620'-0"$ |
| East bank of stream | $30^{\circ}0'$ | $1580'-0"$ |
| O2 | $240^{\circ}0'$ | $3105'-0"$ |
| P.C. on highway ϵ (1000 Rad) | $321^{\circ}0'$ | $1230'-0"$ |
| Northwest corner of barn | $311^{\circ}10'$ | $502'-0"$ |
| Northeast corner of barn | $295^{\circ}15'$ | $780'-0"$ |
| South bank of stream | $236^{\circ}0'$ | $985'-0"$ |
| ϵ of 150' R.R. bridge | $214^{\circ}0'$ | $970'-0"$ |
| West bank of stream | $180^{\circ}0'$ | $1060'-0"$ |
| West bank of stream | $165^{\circ}0'$ | $1550'-0"$ |
| O1 Locate Sta No.1. 200'-0" from left border line & 1200'-0" from the lower border line. | | |

These notes read up the page

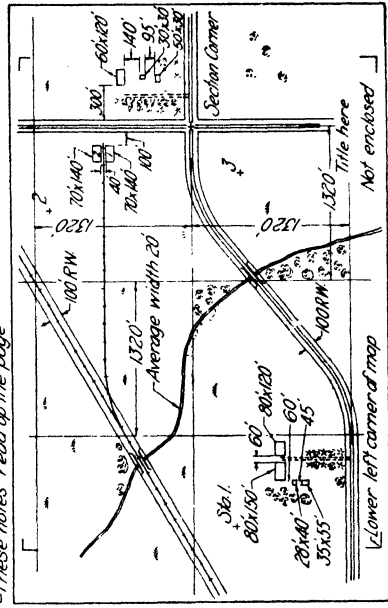

FIG. 20.

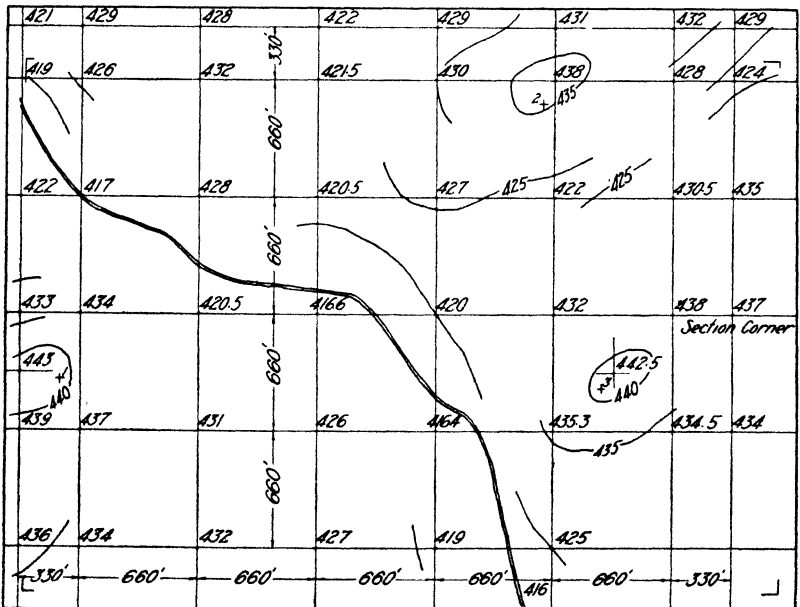

FIG. 21.

UNIT XXX

DETAILS OF BUILDING CONSTRUCTION

PURPOSE OF UNIT XXX

The purpose of this unit is to present some of the fundamental details of building construction and to show how to draw details.

WHAT YOU SHOULD KNOW ABOUT BUILDING DETAILS

Before anyone can prepare the plans for a building, he must be familiar with the commonly used details of construction. In this text, only those types of construction used in building modern homes will be studied.

Many of the details of construction are standardized and need not be represented in the form of detailed drawings, since every experienced builder is familiar with them, but the draftsman must understand them so that his plans will not conflict with such standard details.

Common types of construction. There are two common types of construction which may be classified respectively as (1) wood or frame construction, and (2) masonry construction. These may be subdivided, according to the exterior finish or covering used, as follows:

| Wood | Masonry |
|---------------|-----------------------|
| Weather board | Solid brick |
| Shingle | Tile and brick veneer |
| Stucco | Tile and stucco |
| Brick veneer | Solid stone |
| Stone veneer | Tile and stone veneer |

Houses may be built of combinations of both kinds of construction; for example, the lower story may be of brick and the upper of stucco. Typical wall sections of several of these types of construction are shown in Figs. 1 to 4.

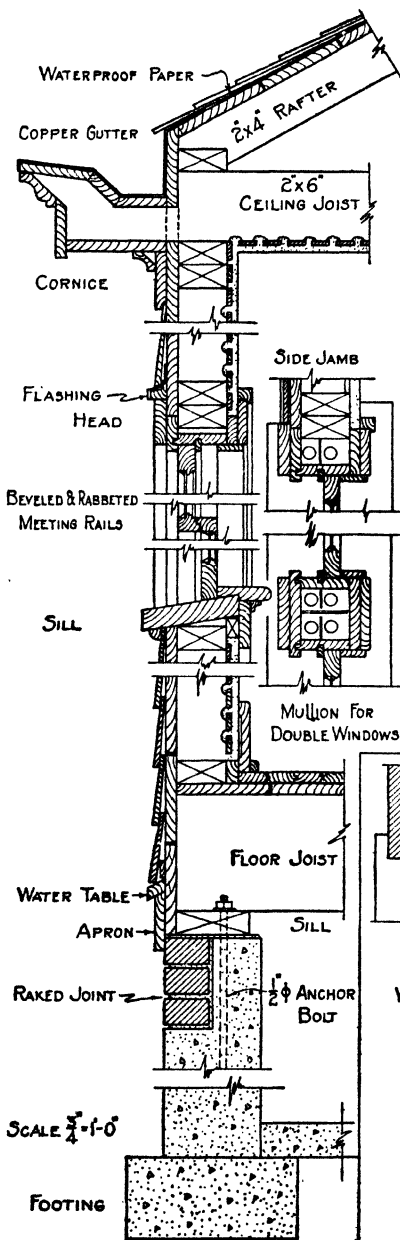

FIG. 1. Wall section. Frame building.

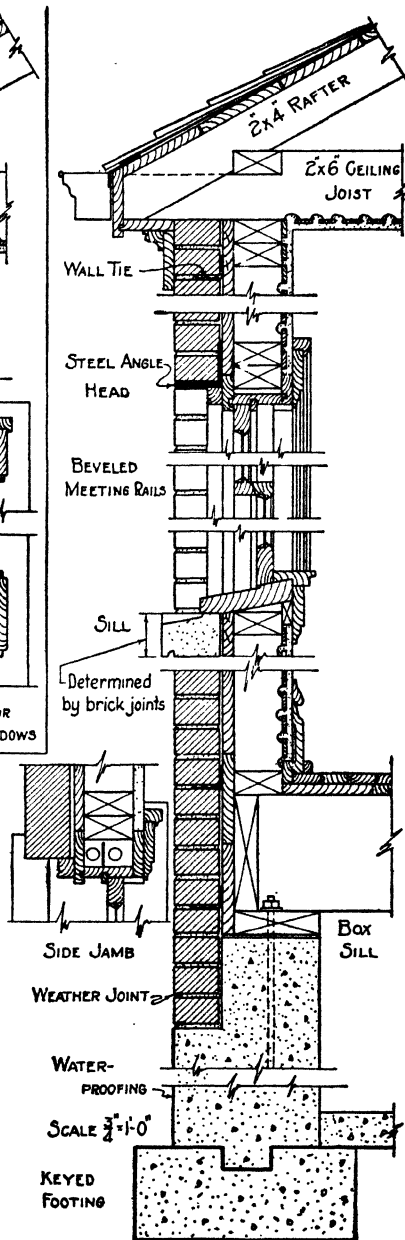

FIG. 2. Wall section. Brick veneer building.

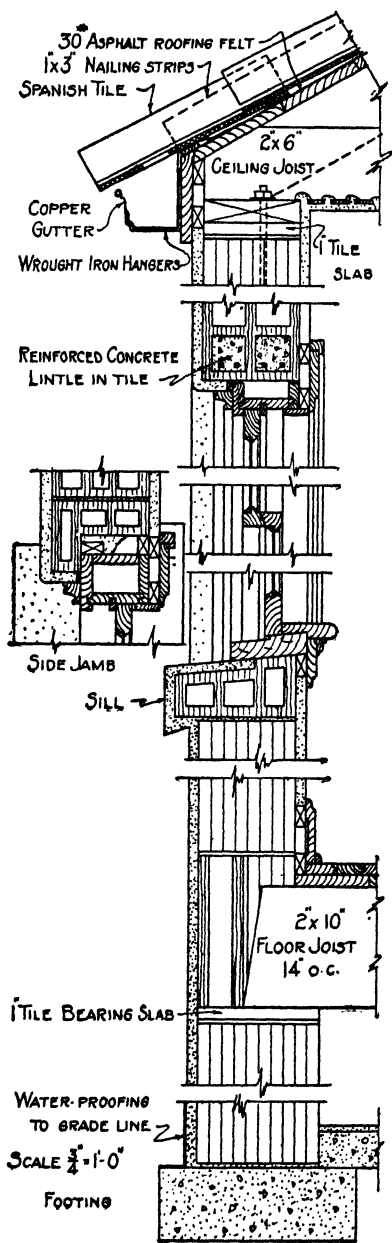

FIG. 3. Wall section. Stucco on tile.

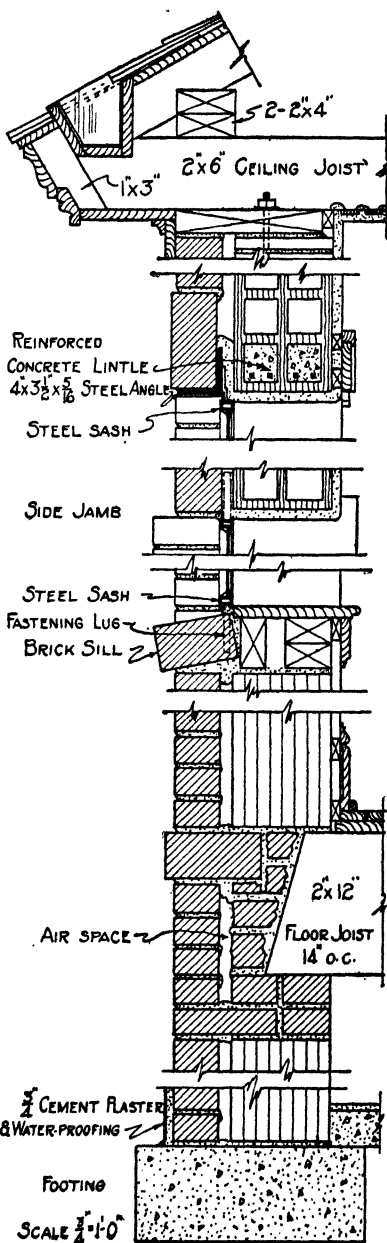

FIG. 4. Wall section. Brick and tile.

Common details. In each type of construction the draftsman must be familiar with certain details which occur in all buildings. The following list and the illustrations of this unit cover the more common details, which, of course, may be made in almost endless variety. As an aid in preparing such details the draftsman should have at hand, for reference, the manufacturers' catalogues of the materials and equipment which he proposes to use. These catalogues usually specify stock sizes and frequently show detailed drawings of construction recommended by the manufacturer. The use of stock and standard sizes is desirable in the interest of economy and speed in construction when not opposed to more important considerations of design affecting beauty or use.

Commonly Used Details

| | |
|------------------------------------|---------------------------------------|
| Wood framing, Fig. 5. | Cornice details, Figs. 1 to 4 and 15. |
| Footing details, Figs. 1 to 4. | Fireplace details, Fig. 16. |
| Sill construction, Fig. 6. | Stair details, Fig. 18. |
| Window details, Figs. 8, 9 and 10. | Interior trim and moldings, Fig. 17. |
| Door details, Figs. 11 and 12. | |

Wood framing. Figure 5 illustrates the type of framing commonly employed in ordinary frame houses, and upon it are indicated many of the terms used in building construction. The spacing of joists and rafters is determined by the requirements of strength and rigidity. Twelve, sixteen and eighteen inches are the spacings commonly used. Studding is usually placed 16 inches on centers since this fits the requirement of 32- and 48-inch standard plaster lath. The cross-section of a lath is $\frac{3}{8}$ "x $1\frac{3}{8}$ ".

The sheathing may be wood boards, in which case it is usually laid diagonally to secure greater strength. Sometimes large sheets of specially manufactured material for sheathing are used instead of wood boards. On the inside, lath and plaster may be used, or any one of a variety of prepared composition boards may be used instead of lath.

The space between studding may be left empty or, as in

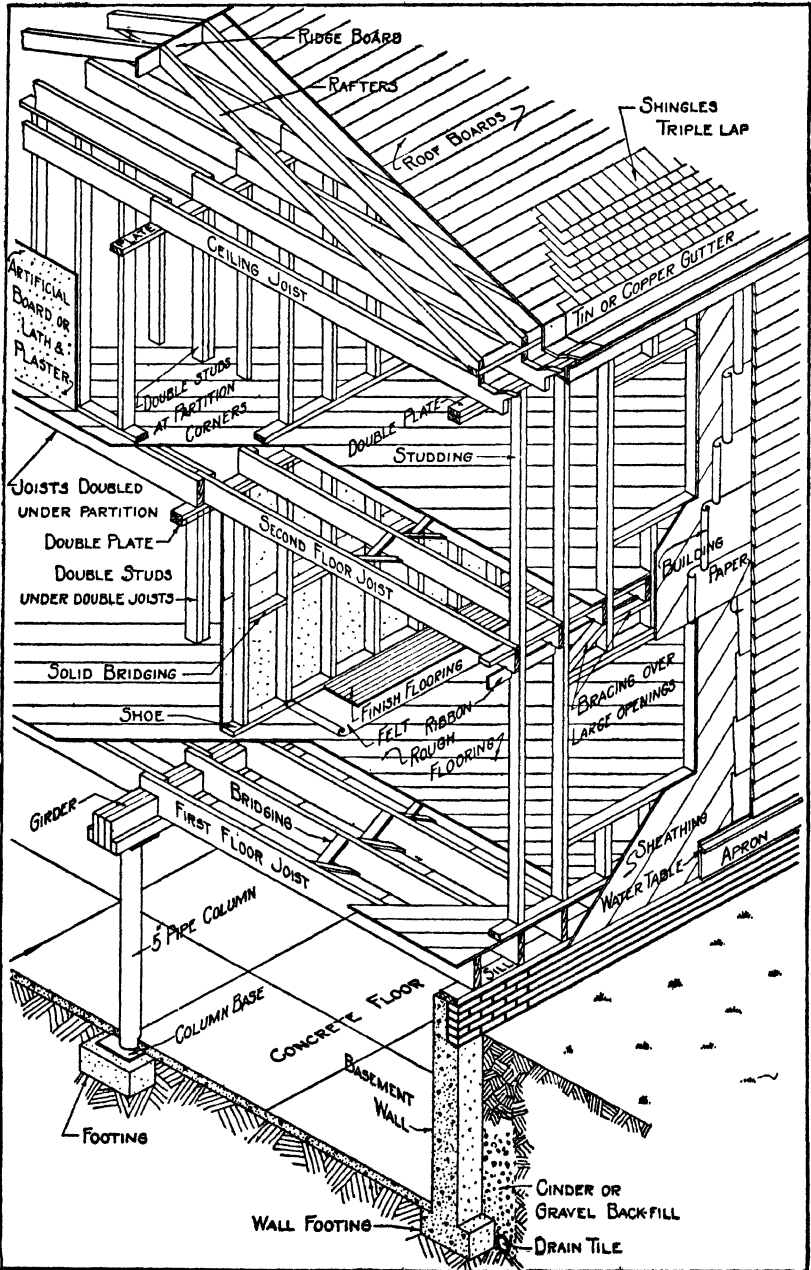

FIG. 5. House framing.

the better class of dwellings, it may be filled with any of various kinds of insulating material to keep in heat during the winter and to keep the house cool in the summer.

Lumber dimensions. The size of building lumber is specified in what are called nominal sizes, which are always in even inches as 2"x4", 2"x6" or 4"x8", etc. The actual dimensions are from $\frac{1}{4}$ to $\frac{1}{2}$ inch less than the nominal dimensions. Thus a piece of lumber 2"x4" will actually be about 1 $\frac{5}{8}$ "x3 $\frac{5}{8}$ ". Building lumber is usually finished on one side and one edge only, but it may be obtained finished on any number of sides. The surfacing is indicated by letters and num-

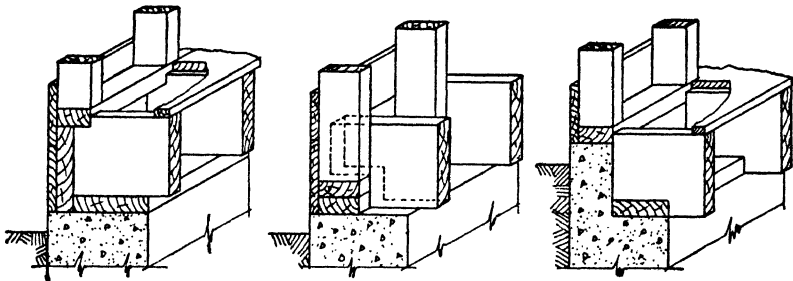

FIG. 6. Box sill details.

bers, as S1S1E, which means surfaced on one side and one edge. S2S2E will be surfaced all over.

Lumber grades. Lumber used for house construction is called yard lumber and is divided into two general grades: (1) Select lumber and (2) Common lumber. Select lumber is graded as A, B, C and D, according to the number and kind of defects and blemishes. Common lumber is graded as Number 1 Common, Number 2 Common, Number 3 Common, Number 4 Common and Number 5 Common. Grade A is the best quality of yard lumber, and Number 5 Common is the worst grade. These grades are known as the American Lumber Standards.

Footing details. The bottom of foundation walls must be broader than the walls to distribute the weight over as large an area of soil as is necessary to avoid undue settlement of

the building. This broadened bottom part of a foundation wall is called the footing of the foundation. Details of foundation footings are shown in Figs. 1 to 4.

Sill details. The sill forms the connection of the foundation wall (always of masonry) with the frame which it supports. Varieties of sill details may be observed in Figs. 1 to 4 and 6. The sill should always be fastened to the foundation by bolts $\frac{5}{8}$ to $\frac{3}{4}$ inch in diameter and 18 to 24 inches long, spaced not more than 9 feet apart.

In masonry structures, wooden joists should have a bearing on the walls of not less than 3 inches, and every sixth or seventh joist should be anchored into the wall with a joist anchor. When joists run parallel to the wall, cross-joist

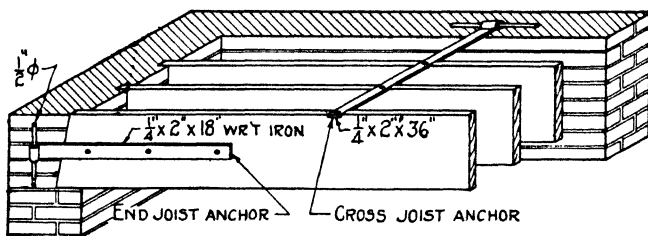

FIG. 7. Floor framing. Masonry construction.

anchors should be placed about 6 to 8 feet apart. The cross-joist anchor should be attached to at least three joists. See Fig. 7.

Window details. Windows which were formerly always made of wood in residence work are now also made of steel or sheet metal. A few common types of construction are shown in Figs. 1 to 4 and 8, 9 and 10. The dimensions of commonly used wood sash and the styles of sash usually found are shown in Fig. 11. The glass sizes are in even inches. For stock sizes, manufacturers' catalogues should be consulted. Also, for steel and sheet metal window details the manufacturers' catalogues should be studied.

Door details. The common methods of constructing interior and exterior door frames are shown in Figs. 12 and

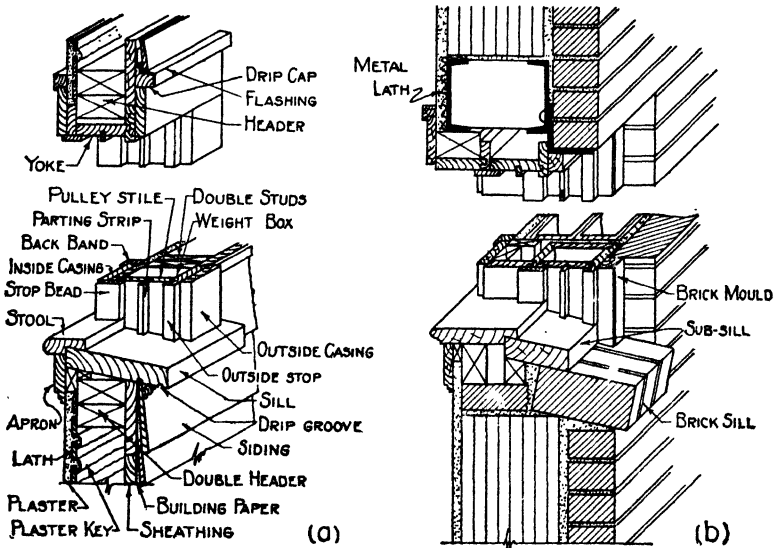

FIG. 8. Window details. Frame and masonry walls.

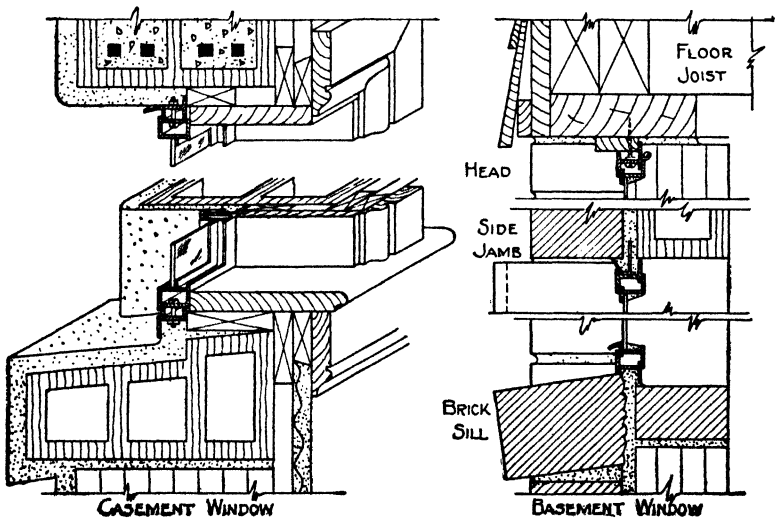

FIG. 9. Steel sash windows.

13; the common types of doors are shown in Fig. 14. Interior doors are usually $1\frac{3}{8}$ inches thick, and exterior doors are frequently made $1\frac{3}{4}$ inches thick. Details of ornamental

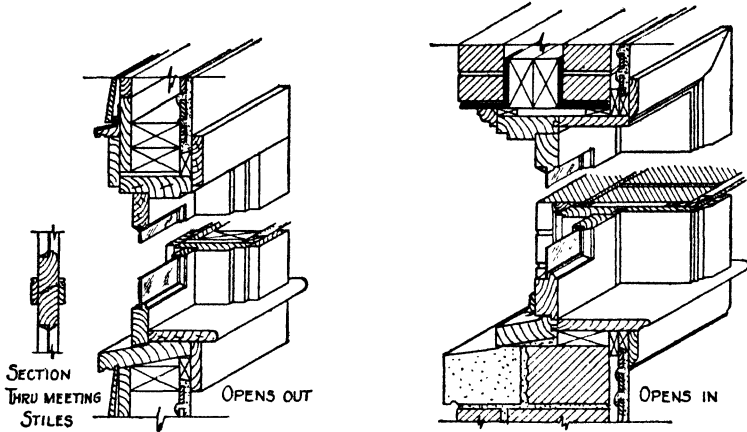

FIG. 10. Casement windows.

doors and door trim may be found in great variety by consulting manufacturers' catalogues.

Cornice details. The style of cornice used depends upon the type of architecture, but almost endless variations can

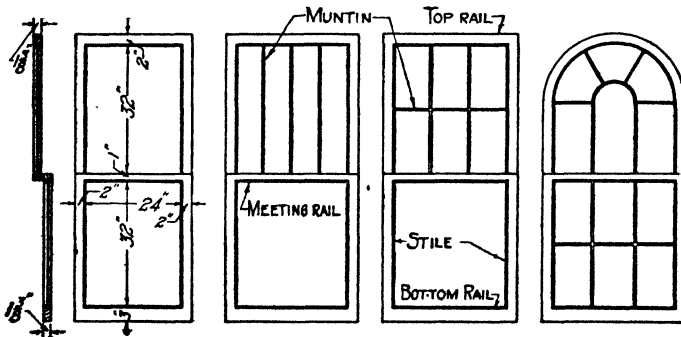

FIG. 11. Window sash.

be produced in any style. The essential elements of a cornice may be observed in Figs. 1 to 4 and in Fig. 15.

Fireplace details. Construction of a fireplace without any patented devices is shown in Fig. 16. Fireplace and furnace

flues should always be lined with tile. Joists or rafters should not be permitted to have a bearing in any flue wall. The

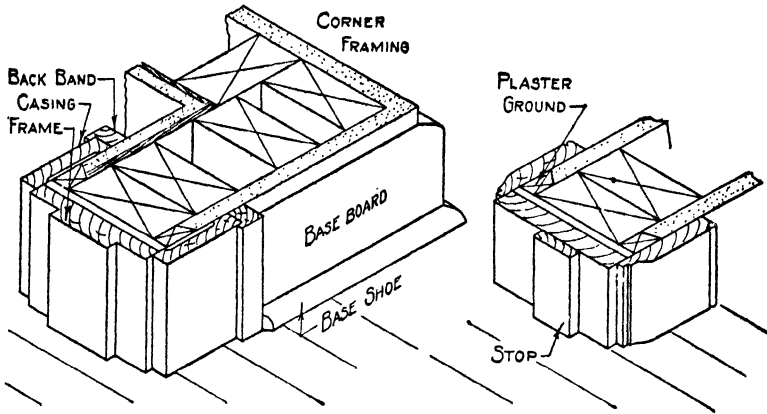

FIG. 12. Interior door framing.

flue area of a fireplace should be about one-tenth the area of the fireplace opening.

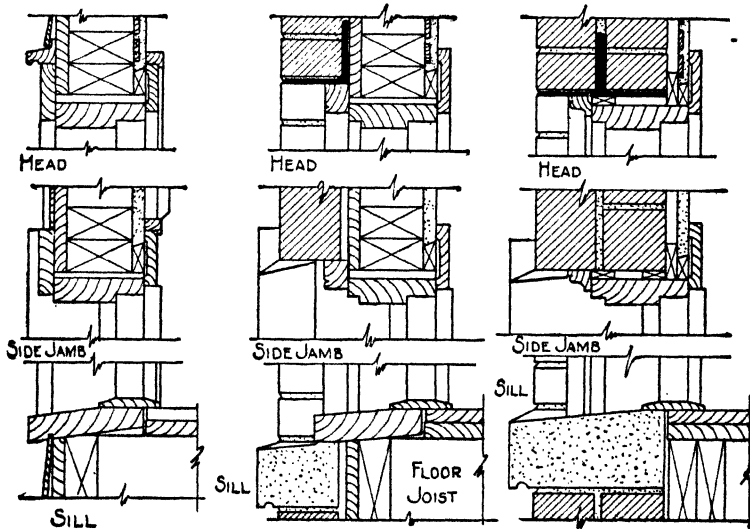

FIG. 13. Exterior door framing.

Interior trim. Interior trim is made to harmonize with the window and door trim. Some of the moldings commonly

used are shown in Fig. 17. Special moldings may be made in any desired shape but should be designed so that they may be cut from stock sizes of lumber such as the 2"x4", etc.

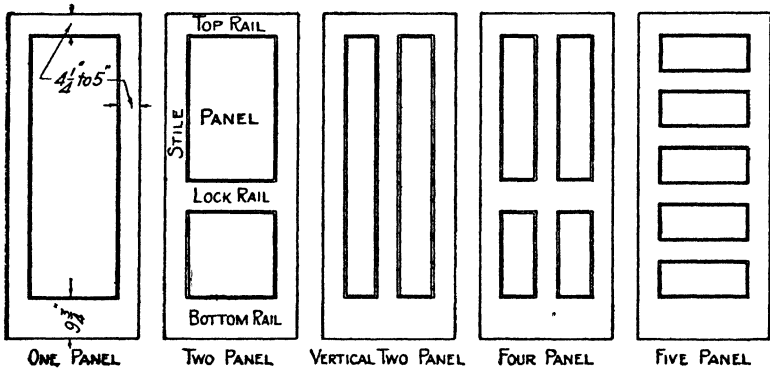

FIG. 14. Common types of doors.

Stair details. Stairways frequently form one of the most difficult parts of house framing. Figure 18 illustrates stair details and gives the names of the various parts. To make

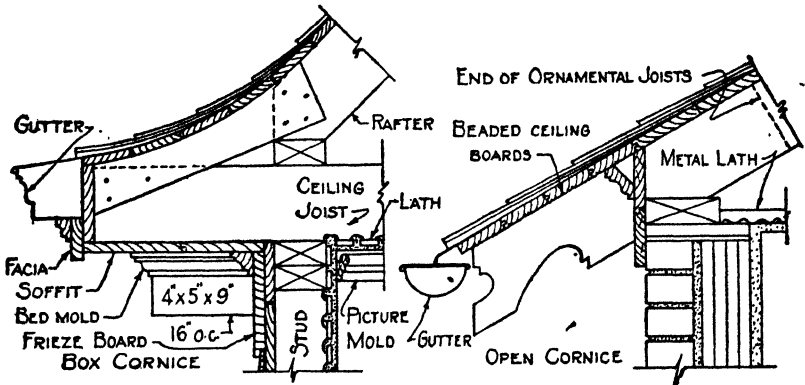

FIG. 15. Cornice details.

a comfortable stairway, that is one that is easy to go up and down, the following rule should be observed: the sum of two risers and one tread should equal 25 inches. The riser should not exceed $7\frac{3}{4}$ inches.

Another important item is to see that there is proper head room in the stairway. This should not be less than 7'-0". When there is any question as to head room it is best to draw a section through the stairway using a scale of $\frac{1}{2}$ " to 1'-0" or larger. This will enable you to determine

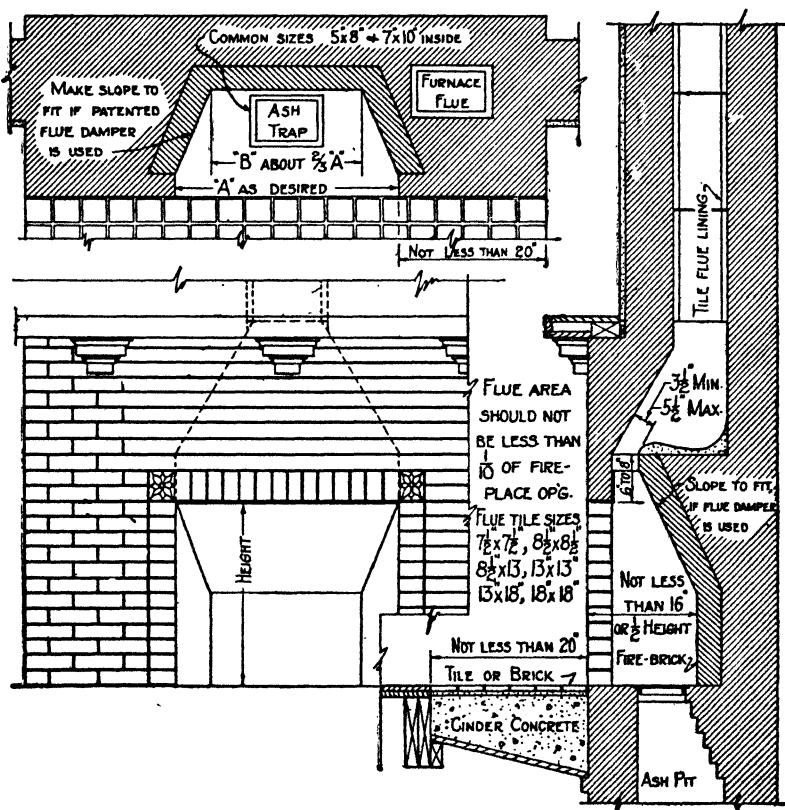

FIG. 16. Fireplace details.

clearly the exact head room possible with the kind of stairway you are considering.

HOW TO DRAW DETAILS

To draw details. It is important in drawing details that you have a clear mental picture of the detail to be drawn before beginning. Study carefully the figures given in this

unit, then examine parts of some house, such as the cornice, the windows, doors, stairs, etc., and try to picture in your "mind's eye" just how a cross-section of the part examined would appear. When the image in your mind is clear, begin the drawing by first drawing the dominant member of the detail, that is, the member which controls the location and relation of the other members. For example, in Fig. 15 every part of the cornice depends for its location on the location of the wall and plate. Hence it is well to draw the

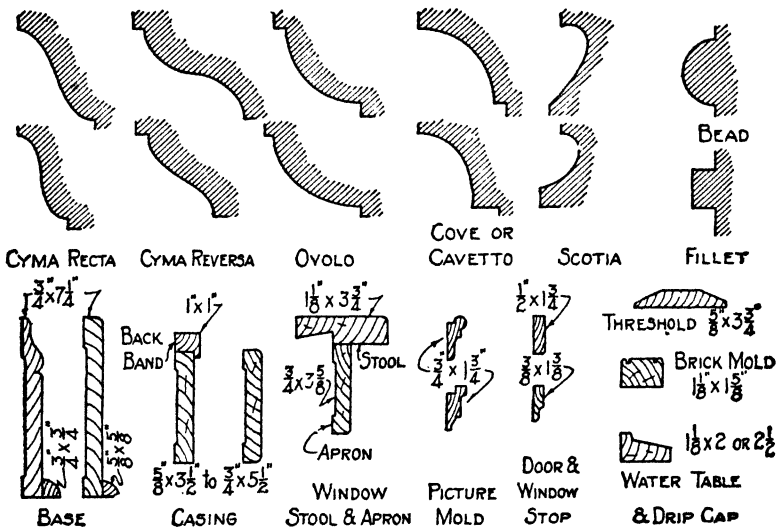

FIG. 17. Moldings and interior trim.

wall and the plate first. After drawing the members which determine the location of the other members, proceed in what seems to be the most convenient order to draw the other members. Usually it is convenient to draw the members in the same order in which you would have to assemble them if you were actually building the detail. Examine several detail drawings and think what would be the best order of drawing the various parts of them.

Dimensions of details. The outside dimensions of such details as cornices, openings, ornaments, etc., are taken from

the plans and elevations, if they are shown on them. The other dimensions and all dimensions of details not shown on plans or elevations must be worked out on the drawing board according to need and desire. All standardized details,

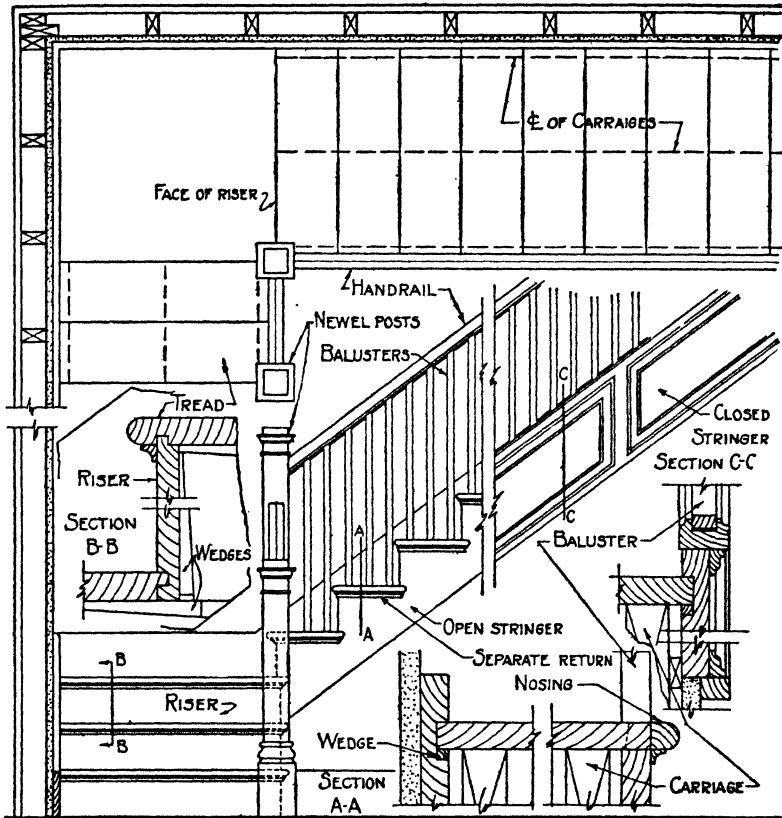

FIG. 18. Stair detail.

such as moldings, casings, window sash, etc., may be taken from manufacturers' catalogues.

QUESTIONS

1. What is the purpose of a detail drawing?
2. What are the different kinds of walls used in house construction?
3. In a building detail how do you represent (1) mortar, (2) plaster,

(3) moldings and other finish trim, (4) framing timbers, (5) brick and (6) tile?

4: Describe the porch detail shown on the detail sheet in Fig. 19.

5. Tell how the stair shown in the detail in Fig. 18 is built.

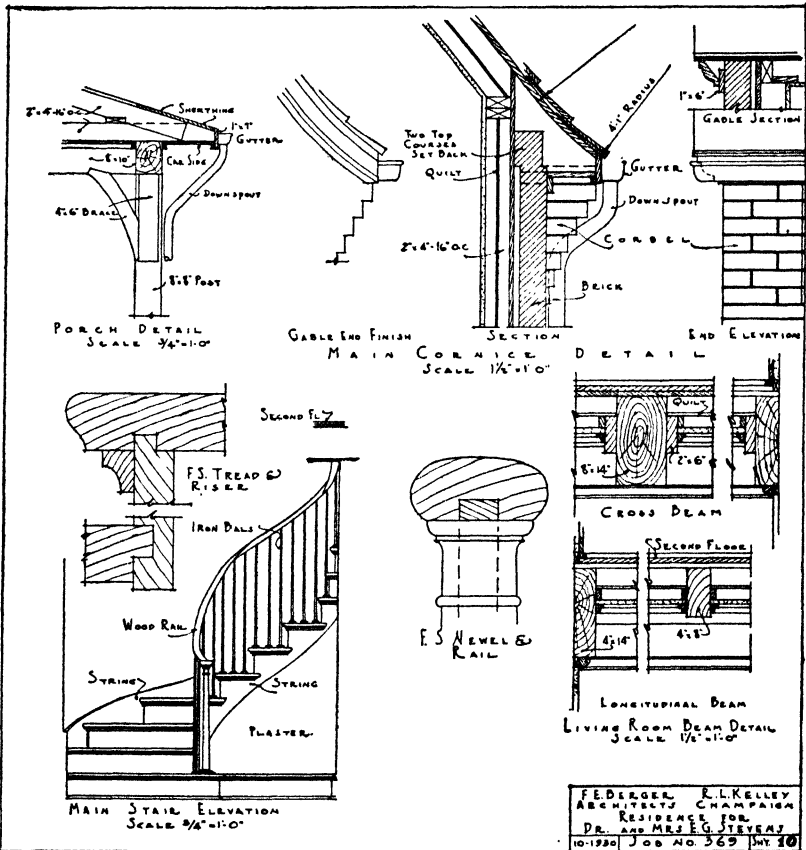

Courtesy of Berger and Kelley, Arch'ts

FIG. 19. Details from set of house plans.

6. What are the different grades of lumber used in building construction?

7. What is an open cornice? What is a boxed cornice?

8. What is a double-hung window?

9. What is a casement window?

10. Make a sketch of a door and name the parts on the sketch.

PROBLEMS*

Lay out standard border line and title space; then make the details assigned from the following list.

1. Make a detail drawing of one of the sills shown in the isometric drawing in Fig. 6.

2. Make a detail of the window sill shown in Fig. 8b.

3. Make a detail drawing of the wall section shown in the isometric drawing in Fig. 5.

4. Using a manufacturer's catalogue to get dimensions, make a detail drawing of the steel casement sill shown in Fig. 9.

5. Using a manufacturer's catalogue for dimensions, make detail drawings of an ornamental front door with a semicircular top, for a small brick house.

6. Using a manufacturer's catalogue for dimensions, make a sheet of moldings, casings, thresholds, water tables, window stools, etc., as shown in Fig. 17 or as assigned by your instructor.

7. Make a detail of an open cornice similar to that in Fig. 15 but using your own design. Make the cornice for a frame house and use a $\frac{1}{4}$ pitch roof, that is, the rafter to run 30 degrees to the horizontal.

8. Make a detail of a fireplace and flue for a small frame house, dimensions as assigned by your instructor.

9. Draw the details of a stairway as assigned by your instructor.

* An excellent source of standard details of all kinds will be found in "Architectural Graphic Standards," second edition, by C. G. Ramsey and H. R. Sleeper, 284 pages. Published by John Wiley & Sons, New York. This book should be available for reference in every architectural drafting room.

UNIT XXXI

FLOOR PLANS OF BUILDINGS

PURPOSE OF UNIT XXXI

It is the purpose of this unit to explain the principles of drawing involved in making floor plans and to indicate what information must be placed upon the plans that would not appear there according to the rules of projection alone.

WHAT YOU SHOULD KNOW ABOUT FLOOR PLANS

How floor plans differ from other drawings. Building plans are based upon the same principles of projection as all other drawings, but they differ in certain minor aspects. Since buildings are so much larger in proportion to the size of the paper than are the objects shown in the ordinary shop drawing, it becomes necessary, as a rule, to show only one view on a sheet. Thus the front view will be on one sheet and the side and rear views each on another; the floor plans likewise each occupy a sheet. See Figs. 1, 2, 3 and 4 of Unit XXXII. Even with only one view on a sheet the scale is much smaller than that commonly used for shop drawings. Scales of $\frac{1}{8}'' = 1'-0''$ and $\frac{1}{4}'' = 1'-0''$ are the ones most commonly used.

Use of symbols. With such small scales, objects cannot be represented as they actually are but must be shown by means of symbols which are commonly recognized as representing the objects. Such things as doors, windows, radiators, registers, etc., are indicated by means of symbols. Door and window symbols are shown in Fig. 1. A system of cross-hatching symbols to represent different materials used in construction is shown in Fig. 2.

Another difference between architectural working drawings and machine drawings is that a single top view, which

usually suffices in machine drawing, is not enough for building work. A series of top views, or plans, one for each floor, must be made.

What floor plans are. From the viewpoint of the theory of projection, a floor plan is a horizontal sectional view made

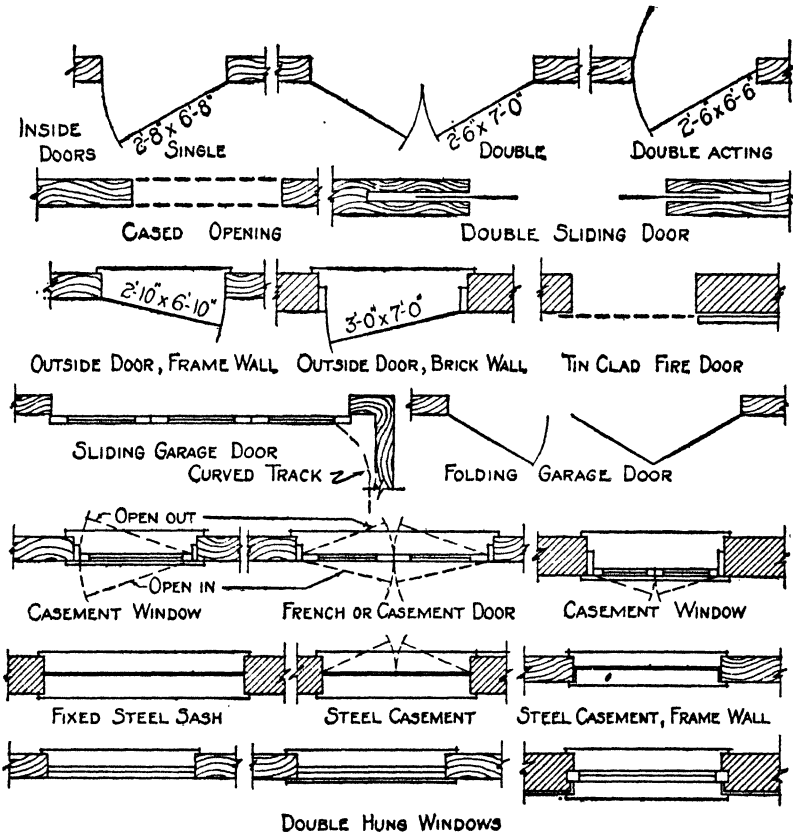

FIG. 1. Door and window symbols.

with the observer looking down. The cutting plane is thought of as passing through the building in such a manner that it cuts through all wall openings, as illustrated in the small garage of Fig. 3. The section plane is imagined as being offset up or down whenever necessary to show all openings in the walls. As in any sectional view, the part of the build-

| BUILDING MATERIAL SYMBOLS | | | |
|---------------------------|---------|------------|--------------|
| MATERIAL | IN PLAN | IN SECTION | IN ELEVATION |
| BRICK | | | |
| STONE | | | |
| CONCRETE (STONE) | | | |
| CONCRETE (CINDER) | | | |
| HOLLOW TILE | | | |
| TERRA COTTA | | | |
| MARBLE | | | |
| METAL | | | |
| WOOD | | | |
| PLASTER | | | |
| INSULATION | | | |
| EARTH | | | |
| | | Rock | |
| | | | CINDERS |

FIG. 2. Building material symbols.

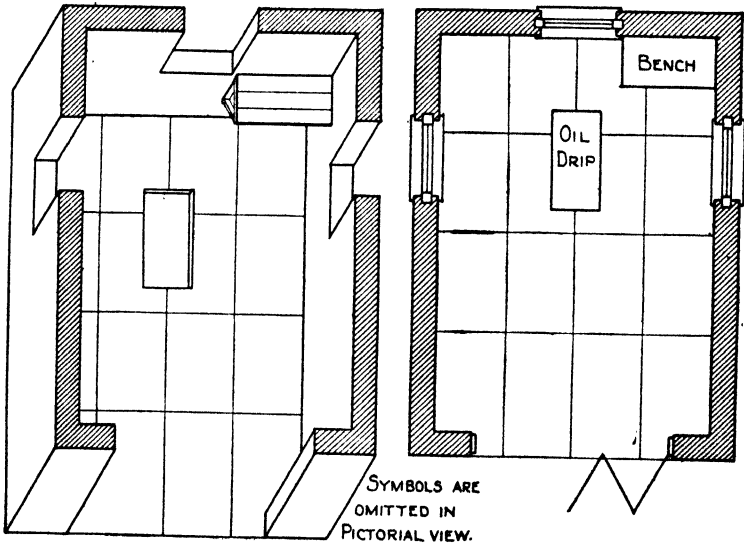

FIG. 3. Meaning of a floor plan.

ing between the cutting plane and the observer is imagined to be removed. A floor plan is required for each floor of a building, including the basement plan. If several floors are

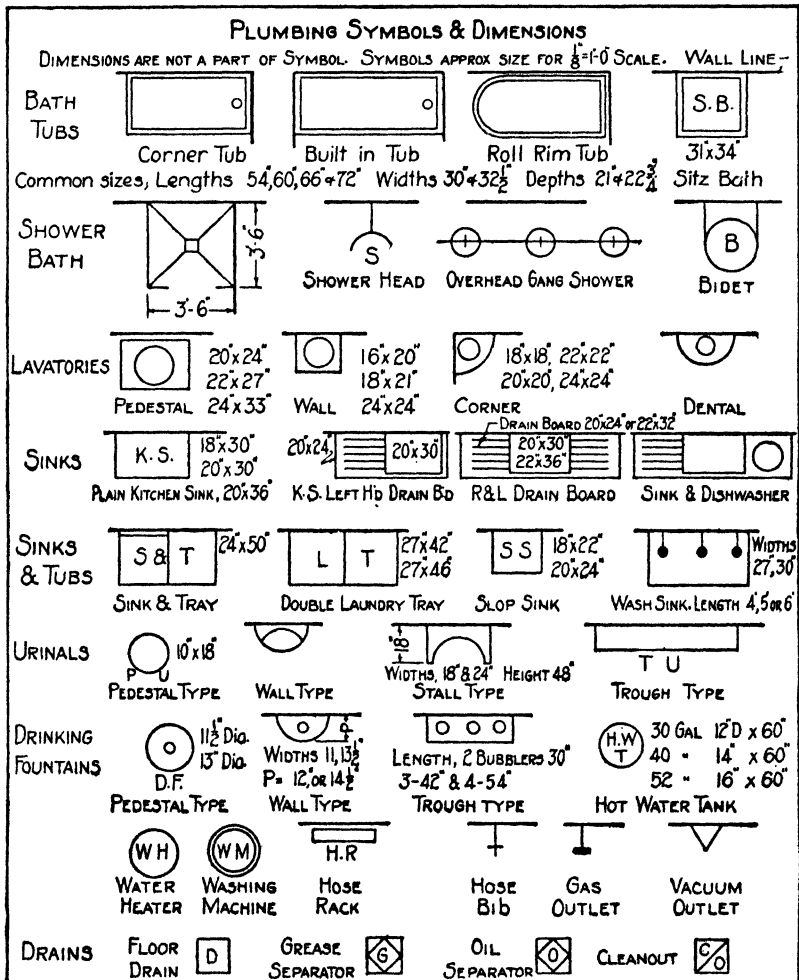

FIG. 4. Plumbing symbols.

exactly alike, as is frequently true of tall buildings, only one plan need be made for them, and the title of the sheet explains to which floors the drawing applies. The roof plan

is, of course, a real top view and should be included in a complete set of plans and elevations. The front and side views of a building are called elevations.

What is shown on floor plans. A floor plan always shows those things which appear according to the regular rules of orthographic projection, such as the walls with all door and window openings, permanent cabinets, radiators, floor and









































| STANDARD SYMBOLS FOR ELECTRICAL EQUIPMENT OF BUILDINGS | | | |
|---|---|---|---|
|  | CEILING OUTLET |  | S^D AUTOMATIC DOOR SWITCH |
|  | CEILING OUTLET (GAS & ELECTRIC) |  | MOTOR |
|  | CEILING LAMP RECEPTACLE - SPECIFICATIONS TO DESCRIBE TYPE |  | MOTOR CONTROLLER |
|  | CEILING OUTLET FOR EXTENSIONS |  | LIGHTING PANEL |
|  | CEILING FAN OUTLET |  | POWER PANEL |
|  | DROP CORD |  | HEATING PANEL |
|  | FLOOR OUTLET |  | METER |
|  | WALL BRACKET |  | TRANSFORMER |
|  | WALL BRACKET (GAS & ELECTRIC) |  | BRANCH CIRCUIT, RUN CONCEALED UNDER FLOOR ABOVE |
|  | WALL OUTLET FOR EXTENSIONS |  | BRANCH CIRCUIT, RUN EXPOSED |
|  | WALL FAN OUTLET |  | BRANCH CIRCUIT, RUN CONCEALED UNDER FLOOR |
|  | WALL LAMP RECEPTACLE - SPECIFICATION TO DESCRIBE TYPE |  | PUSH BUTTON |
|  | SINGLE CONVENIENCE OUTLET |  | BUZZER |
|  | DOUBLE CONVENIENCE OUTLET |  | BELL |
|  | JUNCTION BOX |  | INTERIOR TELEPHONE |
|  | SPECIAL PURPOSE OUTLET - LIGHTING, HEATING AND POWER AS DESCRIBED IN SPECIFICATIONS |  | PUBLIC TELEPHONE |
|  | LOCAL SWITCH - SINGLE POLE |  | THIS CHARACTER MARKED ON TAP CIRCUITS INDICATES 2 No. 14 CONDUCTORS IN $\frac{1}{2}$ " CONDUIT. |
|  | LOCAL SWITCH - DOUBLE POLE |  | 3 No. 14 CONDUCTORS IN $\frac{1}{2}$ " CONDUIT |
|  | LOCAL SWITCH - 3 WAY |  | 4 No. 14 CONDUCTORS IN $\frac{3}{4}$ " CONDUIT |
|  | LOCAL SWITCH - 4 WAY |  | 5 No. 14 CONDUCTORS IN $\frac{3}{4}$ " CONDUIT |

FIG. 5. Electric wiring symbols.

wall registers and all plumbing features. Because of the scale of a plan, practically all these things have to be shown by symbols. Plumbing symbols commonly used are given in Fig. 4; symbols for electric outlets, in Fig. 5; and heating and ventilating symbols in Fig. 6.

In addition to the things which a drawing would be required to show by the rules of projection, it is often neces-

sary to indicate certain other objects, such as the beams and joists below the floor which support it. Lighting outlets in the wall and ceiling are also shown, even though they are above the cutting plane, since there is no other place to show them. The actual lighting fixtures are usually not drawn unless they are of special design to fit the building.

Ornamental ceiling construction, unless it is very elaborate, is also shown by a typical portion on the floor plan. If the ornamental work is too elaborate to be shown in this manner, separate drawings are made for it.

| HEATING & VENTILATING SYMBOLS | | |
|----------------------------------|------|--|
| NAME | PLAN | ELEVATION |
| COLUMN RADIATOR | | |
| WALL RADIATOR | | |
| PIPE COIL | | |
| INDIRECT RADIATOR | | |
| SUPPLY DUCT (SECTION) | | EXHAUST DUCT (SECTION) |
| BUTTERFLY DAMPER | | |
| DEFLECTING DAMPER SQUARE PIPE | | VANES AIR SUPPLY OUTLET EXHAUST OUTLET |

FIG. 6. Heating and ventilating symbols.

Dimensioning the floor plan. The general rules which govern dimensioning of working drawings hold also for building plans. One point which must be emphasized is that the dimensions must be those which the builder can use. This, of course, requires some experience and a knowledge of standard material sizes. The following suggestions will be found useful.

1. Walls are located by their center lines, except outside walls. The thickness must also be specified for both inside and outside walls.
2. Door and window openings are preferably located

by their center lines and the size specified in notes.
 Doors may be obtained in the following sizes:

- 2'-0" x 6'-0" 2'-8" x 6'-8"
- 2'-0" x 6'-6" 2'-10" x 6'-10"
- 2'-4" x 6'-8" 2'-6" x 7'-0"
- 2'-6" x 6'-6" 2'-8" x 7'-0"
- 2'-6" x 6'-8" 3'-0" x 7'-0"

Inside doors are usually 1 1/2 inches thick; outside doors are generally 1 3/4 inches thick.

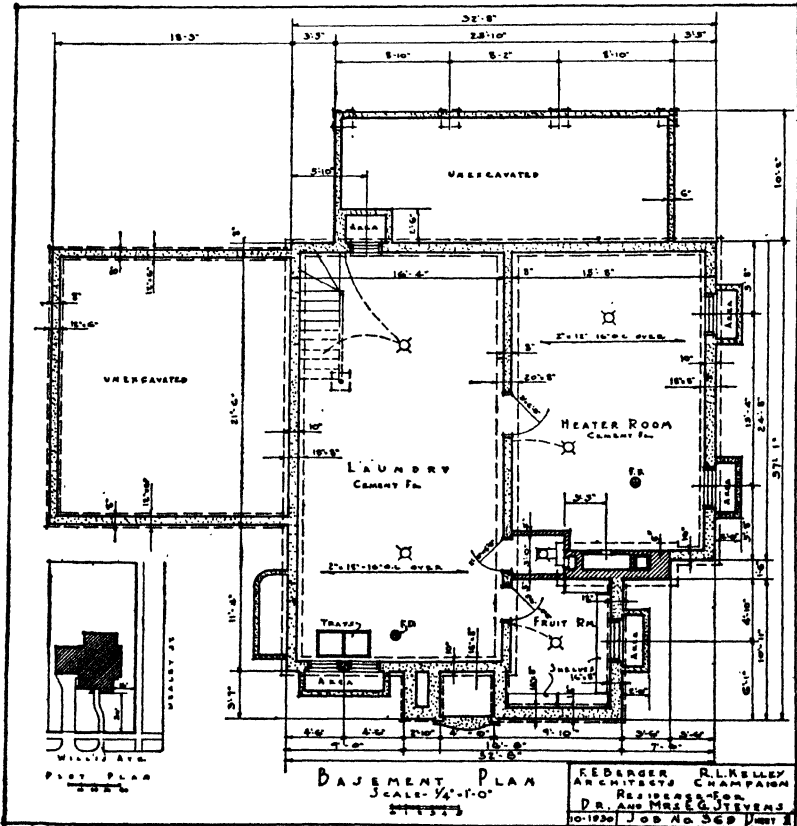

Courtesy of Berger and Kelley, Arch'ts

FIG. 7. Basement and foundation plan.

3. Bathroom and kitchen fixtures may be located either by center lines or outside dimensions.
4. Dimension lines locating interior walls should run

clear across the building in a continuous line if possible.

5. Dimensions locating openings in outside walls should also be arranged in one continuous line. An over-all dimension should accompany such a series of dimensions, but the over-all need not be given on more than one side. See Fig. 7 for the dimensioning on a floor plan.

HOW TO DRAW A FLOOR PLAN

From a freehand sketch, either made by yourself or secured from some other source, which gives the necessary information concerning the building which you are to draw, compute the over-all dimensions of the building in two directions at right angles to each other. Decide on the scale you will use, and block out a rectangle of this size, so placed that the drawing sheet will be well balanced.

Within this rectangle lay out the walls of proper thickness in light, solid lines, beginning with the exterior walls; then draw in the interior walls. Next mark off the window and door openings to scale throughout the plan. The arrangement of these details should now be studied to see that they will work out satisfactorily. Doors must be in convenient places and of suitable size. Wall spaces for furniture must be provided, and windows must be carefully located to give suitable light and ventilation. When the arrangement is satisfactory, put in the symbols for the windows and doors.

As you place the symbols indicating windows and doors also draw at the desired locations all such objects as chimneys, closets, built-in cupboards and cabinets, kitchen sinks, bathroom fixtures, etc., using in each case the standardized symbol for the object. A careful check must be made to see that ample room is available for all such fixtures and built-in objects. In order to avoid making a serious mistake in this matter, great care must be exercised to make the symbols exactly to scale and the correct size of the fixture or built-in

You can then easily determine whether doors, windows, wall spaces, etc., are really as you would have them.

The location of radiators or warm-air registers must also be carefully planned and shown by symbols. Place radiators along outside walls. It is usually good practise to locate

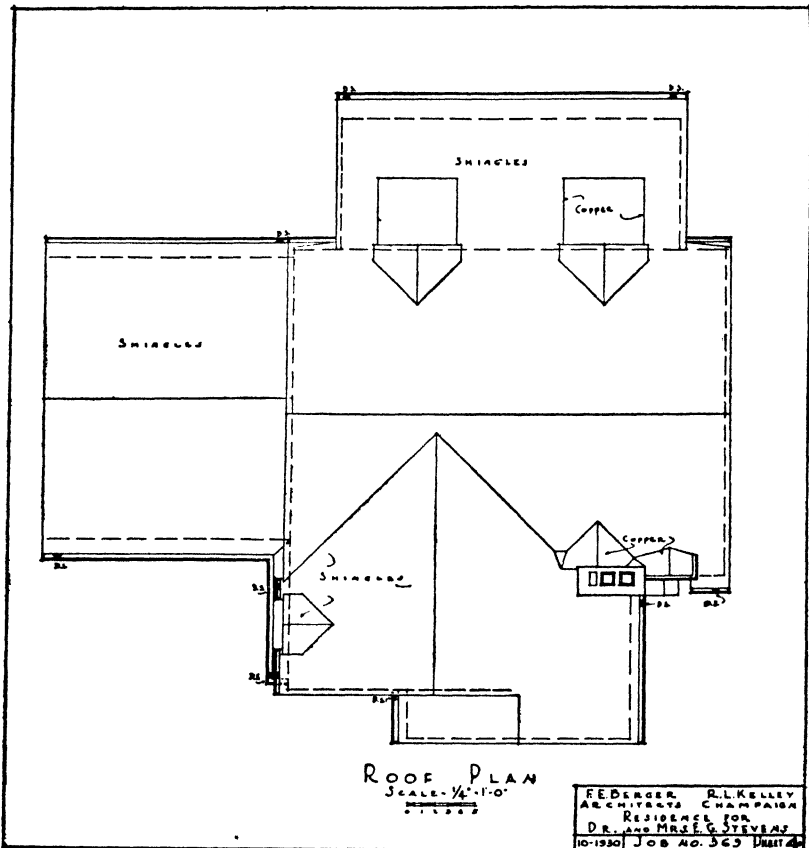

Courtesy of Berger and Kelley, Arch'ts

FIG. 10. Roof plan.

them under windows. They may either stand in the room or be placed in recesses made for them in the wall.

Plan warm-air pipes to run up through inside walls, and place registers at a distance from doors if possible. Place cold-air vents opposite the warm-air registers and if possible

near outside walls. Plan the locations of warm-air pipes, registers, cold-air pipes and vents with great care when working on plans of upper floors so as to avoid interference with doors and other necessary openings or architectural features.

QUESTIONS

1. In what ways do building construction drawings differ from the other working drawings you have studied?
2. What are the scales commonly used for building plans? Why are these scales so generally used?
3. What is a floor plan according to the rules of projection?
4. What things are shown upon floor plans?
5. How are such things as windows, doors and built-in features shown?
6. What things are shown upon floor plans that would not appear there by the rules of projection?
7. Make the symbol for a double-hung window.
8. Make the symbol for a casement window.
9. How are door sizes specified? Illustrate.
10. Is it customary to show the piping for plumbing fixtures? Why?
11. How is the electric wiring represented?
12. How are inside walls dimensioned?
13. How is the location of window and door openings dimensioned? Why?
14. Why is not a top view of a house sufficient?
15. In what position in a room should steam or hot-water radiators be placed? Why?
16. Why should warm-air pipes not be placed in outside walls? Why are cold-air vents placed near outside walls?
17. Why should warm-air registers be placed as far as possible from interior doors?

PROBLEMS*

1. Make the floor plans for one of the houses shown in the following group or in the next unit as directed by your instructor.

* An excellent source of problem material will be found in the various magazines for architects and builders.

2. Make a floor plan for a small house having the same number of rooms as the plan shown in Fig. 11a and with rooms of approximately the same sizes, but make the front wall of the living room continuous with that of the dining room. Run the porch entirely across the front of the house. Use scale $\frac{1}{4}'' = 1'-0''$.

3. Redraw the plan of a house assigned from the following group so that all rooms now on the right side of house will be on the left side, and rooms now on the left will be on the right side. Use scale $\frac{1}{4}'' = 1'-0''$.

4. Plan a house similar to the plan of Fig. 13a or Fig. 14a, but relocate stairs as directed by your instructor.

5. Work out a plan from an original sketch of your own with the general requirements of number and size of rooms as assigned by your instructor.



Deluze Building Co., Los Angeles, Calif.

FIG. 11

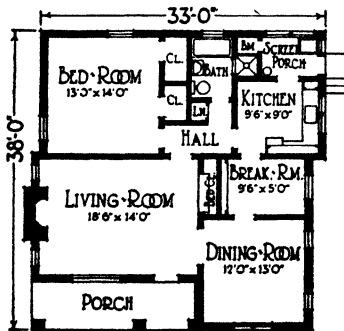

FIG. 11a.

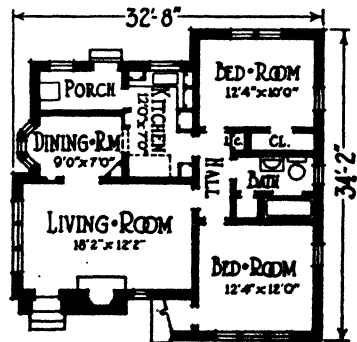
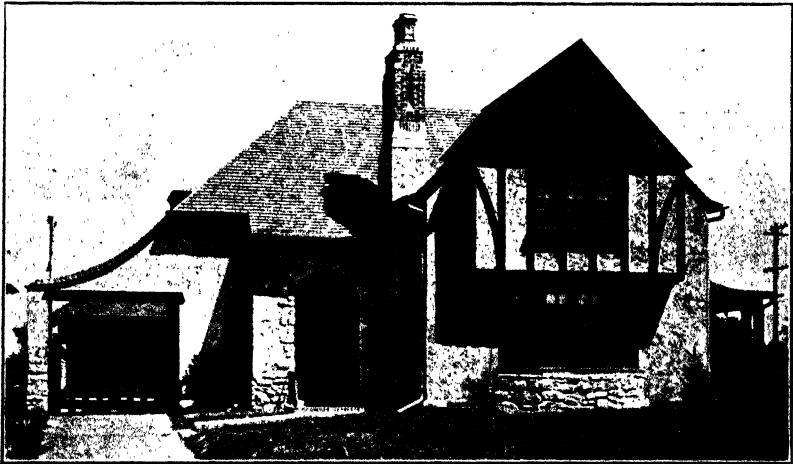

FIG. 12a.



FIG. 12.

A. B. C Arch't



Copyright. The Architects' Small House Service Bureau, Inc.
Plan No. 6-A-64

FIG. 13.

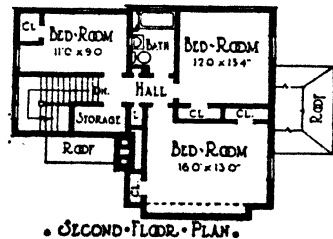
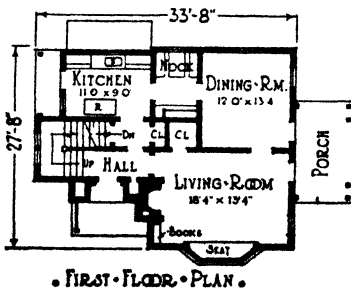

FIG. 13a.

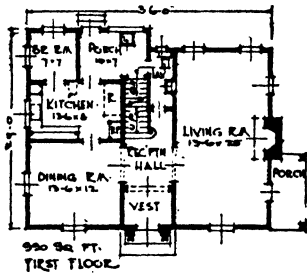
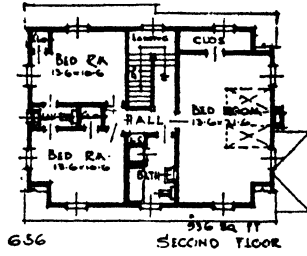

FIG. 14a.



A. B. Cleveland, Arch't

FIG. 14.

Figs. 11 to 14 Courtesy of American Builder and Building Age

UNIT XXXII

ELEVATIONS AND SECTIONS OF BUILDINGS

PURPOSE OF UNIT XXXII

It is the purpose of this unit to explain how to make elevations and section views of buildings, and what constitutes a complete set of plans.

WHAT YOU SHOULD KNOW ABOUT ELEVATIONS

What elevations are. The elevations of buildings correspond to the front and side views drawn of smaller objects. Because of the size of buildings, each elevation is usually made upon a sheet by itself. This fact, however, does not permit the draftsman to violate any of the rules of projection. The floor plans and elevations must correspond, point for point, exactly as though both were on the same sheet and had been constructed by projection from one view to the other. The only difference is that when drawn on separate sheets the construction of plans and elevations must be made entirely by measurement. A scheme for doing this will be suggested later.

With small objects, such as machine parts, only a front, top and side view are usually required. With buildings, however, all four sides must be shown. See Figs. 1, 2, 3 and 4. If, perchance, two sides are exactly alike, then only one of them need be drawn, and a note explaining the similarity of the other side is added.

Style of architecture. Although the statements of the foregoing paragraphs are entirely true, it must not be assumed that only one elevation can be made for any given floor plan. Figure 5 illustrates five different treatments which have been given to the same floor plan. The style of architecture

is shown largely by the elevations, although the floor layout is influenced to some extent by the style which is chosen. Fig. 14, Unit XXXI, represents a Dutch Colonial, whereas Fig. 7, Unit XXXII, is Spanish in type. Colonial and

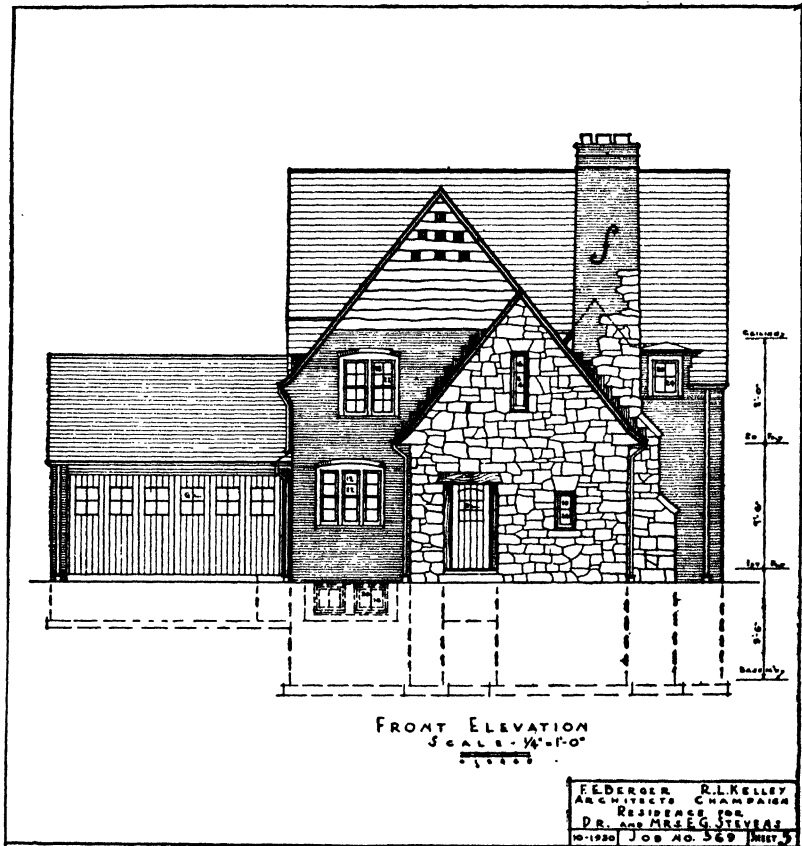

Courtesy of Berger and Kelley, Architects

FIG. 1. Front elevation.

English types are also common in residence work; the Gothic and Romanesque are frequently used in churches and public edifices. Whenever a certain definite style of architecture is decided upon, it should be carried out on the interior as well as the exterior in order to make a harmonious whole.

What information is given on elevations. The elevations show the outside appearance of a building and define its vertical measurements. The vertical distance between floors and the vertical location of all window and door openings and of such ornamental features as may occur are usually

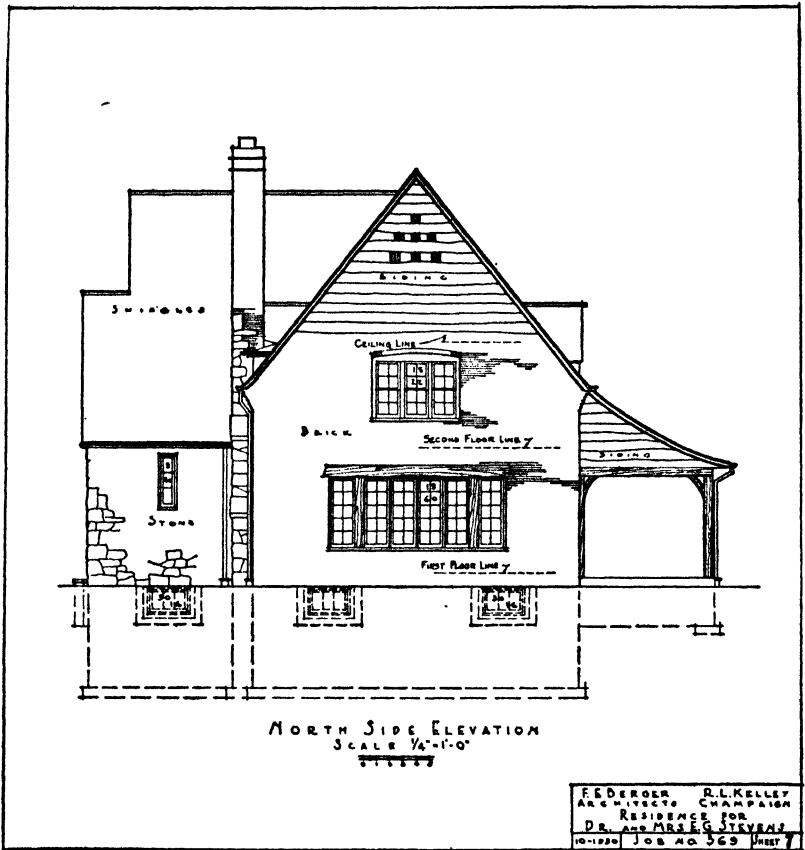

Courtesy of Berger and Kelley, Arch'ts

FIG. 2. North side elevation.

shown on elevations, though the exact measurements for the vertical location of window openings are frequently given in wall sections. Besides giving the vertical dimensions of the side or face of a structure, the elevations show the ex-

terior finish as to both kind and character. Ornamental features such as the trim around window and door openings, the way the brick is to be laid, stone and terra-cotta ornaments, kind and locations of gutters and down spouts, cornices, balconies, etc., must all be represented upon the elevations.

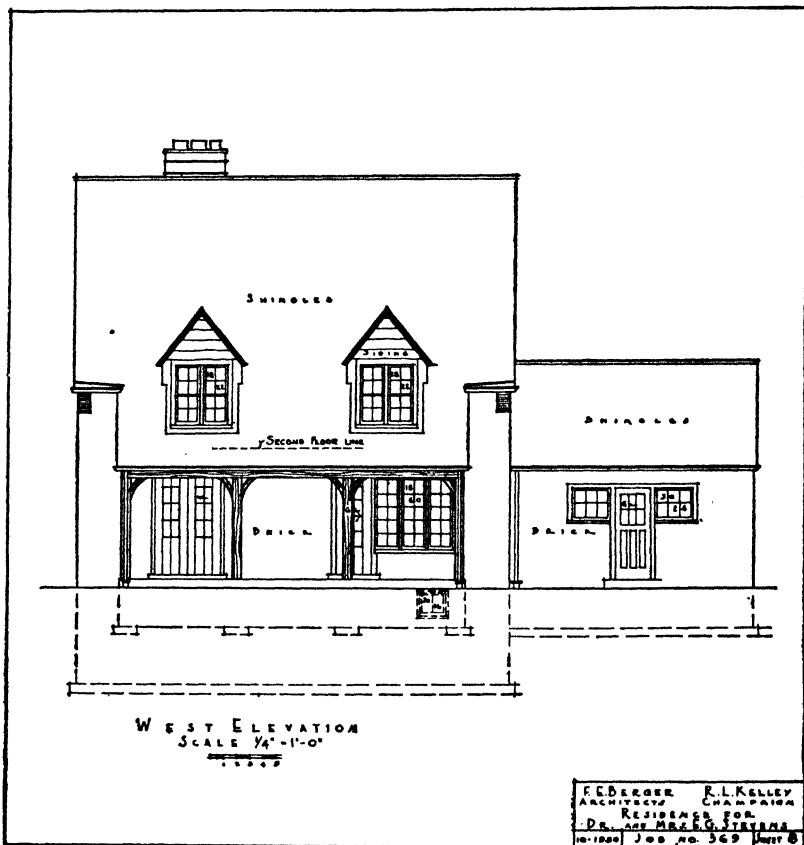

Courtesy of Berger and Kelley, Arch'ts

FIG. 3. West elevation.

Sectional views. In order to show interior construction and finish and the appearance of special features such as stairways, fireplaces and the like, it is necessary to make sectional views of the house, or, perhaps, of only parts of it.

Such views are made upon the same principles of drawing as sectional views in machine drawing and need no further explanations. A knowledge of building construction is essential to the making of such views.

What constitutes a complete set of plans. This unit and those that immediately precede it have briefly dealt with the various kinds of drawings which go to make up a set of plans. By way of review, then, we may summarize what constitutes a complete set of plans. Such drawings may be listed as follows:

1. Plot plan or layout of plot of ground.
2. Foundation and basement plan. See Fig. 7, Unit XXXI.
3. Floor plans (one for each floor). See Figs. 8 and 9, Unit XXXI.
4. Roof plan. See Fig. 10, Unit XXXI.
5. Elevations (one for each different side). See Figs. 1, 2, 3, 4.
6. Sections, where needed.
7. Details (as many as may be needed to show how all parts are to be built). See Fig. 19, Unit XXX.
8. Specifications.

Specifications. The specifications correspond in a measure to the notes which are placed upon a working drawing of a machine part. They describe the things which cannot be shown by drawings, such as the kind and quality of material, the quality of workmanship, the finish of all parts and the conditions of the contract, such as the time of completion of the building, responsibility for various parts of the work, time and method of payment, etc.

Plot plan. The plot plan will show the location of the building upon the lot, the driveways, sidewalks and other buildings such as garages, etc., which may be included in the contract. It will also show the drainage and sewer lines and connections. A small-scale plot plan showing the loca-

tion of the house, driveway and sidewalk is included on the same sheet as the floor plan in Fig. 7 of Unit XXXI.

HOW TO MAKE ELEVATIONS

Having the floor plans completed, draw the elevations to correspond exactly with each other as though both views

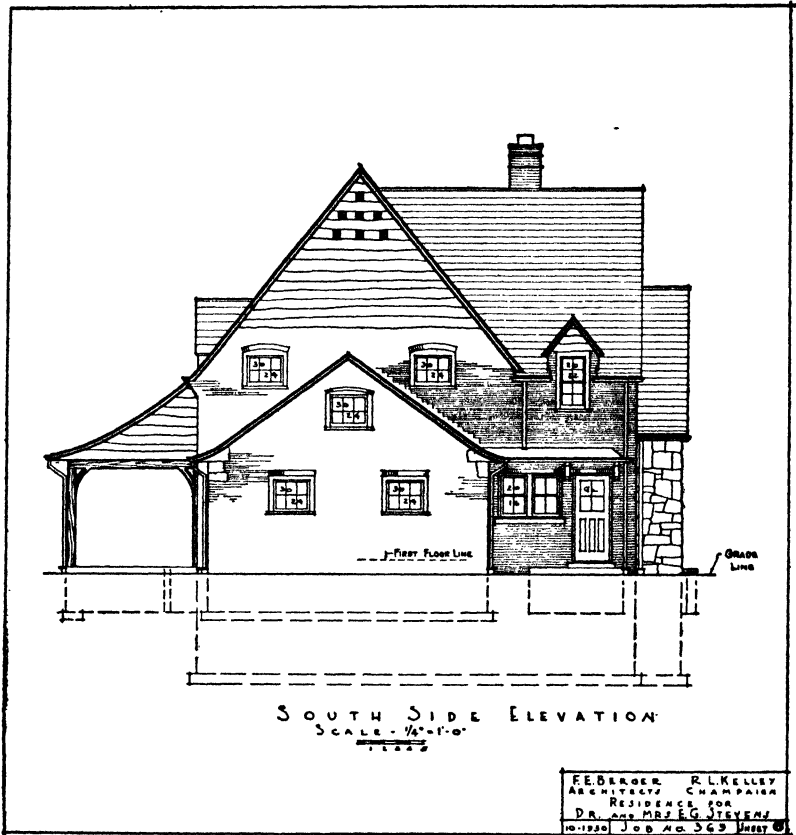

Courtesy of Berger and Kelley, Arch'ts

FIG. 4. South elevation.

were on the same sheet. Compute first the total height of the building from the grade line to the ridge of the roof, and then draw the grade line in such a position that the sheet

will be well balanced vertically when the view is completed. Next draw in lightly the first-floor line and the second-floor line (if any) in their proper positions relative to the grade line.

Now take a narrow strip of tracing paper and lay it over the side of the first-floor plan, whose elevation you are going to make, and mark off on it exactly the total width of the building, the exact location and width of all window openings, chimneys and other features which will appear on the elevation. Transfer this strip to the elevation drawing and lay it along the first-floor line in such a position that the sheet will be well balanced horizontally when the view is completed. From the marks on the strip then lay off the dimensions which will give the exact location of window openings and all other necessary features. The second-story details may likewise be quickly transferred from the second-floor plan in the same way. Study carefully the elevations in Figs. 1, 2, 3 and 4.

After the principal outlines and openings have been drawn, other features such as the cornice, roof lines and ornamental work may be added and the elevation completed.

Use of details. Before some of the foregoing items can be represented upon the elevations it may be necessary to work out large-scale details of such things as the cornice, brick patterns, cut stone and terra-cotta. Such details are usually made with scales from $1\frac{1}{2}'' = 1'-0''$ up to full size. A sheet of details is shown in Fig. 19, Unit XXX. From these drawings one can determine which lines to use to represent the detail clearly upon the small-scale elevation, and also just where it will appear on the elevation. For example, in order to show exactly where the cornice lines will come on the elevation, refer to the detail and locate the position of the various parts of the cornice with reference to the ceiling line, which is, of course, arbitrarily determined. It is usually $8'-0''$ or $8'-6''$ above the floor line. Reference to Fig. 19 in Unit XXX and to Figs. 1 and 4 in this unit will make this point clear.

QUESTIONS

1. Name the eight items that comprise a complete set of plans for a small house.
2. What information should the plot plan give?
3. What information is contained in the elevations?
4. How many elevations of a house must be made?
5. Describe a convenient method for transferring dimensions from the floor plans to the elevations.
6. Why are details frequently necessary in working out an elevation?
7. On which views are the vertical dimensions of a building placed?
8. Outline the order of procedure in making an elevation.
9. Is only one front elevation possible for any given floor plan?
10. What other factor beside the floor plan determines the appearance of the elevation?
11. Name some of the common styles of residence architecture.
12. What materials are used for exterior covering or finish?

PROBLEMS

Draw the elevation specified by your instructor for an assigned house in this or the preceding unit. Use a $\frac{1}{4}$ - or $\frac{1}{8}$ -inch scale, as directed by your instructor. The size of the drawing sheet will be determined by the size of the house and the scale used. Make a title similar to that shown in Fig. 1 of this unit.



Copyright. The Architects' Small House Service Bureau, Inc.

FIG. 6.

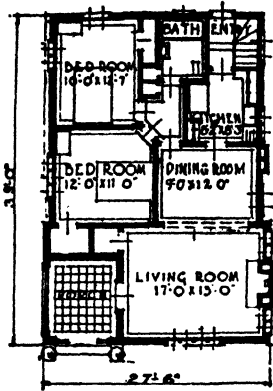

FIG. 6a.

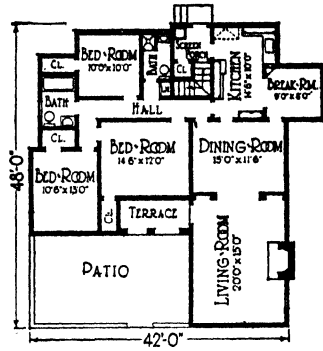

FIG. 7a.



Deluxe Building Co., Los Angeles, Calif.

FIG. 7.



*Copyright, The Architects' Small House Service Bureau, Inc.
Plan No. 6-A-48*

FIG. 8.

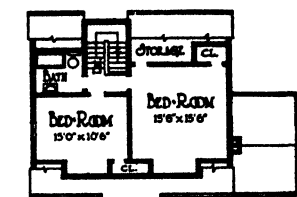

• SECOND FLOOR PLAN •

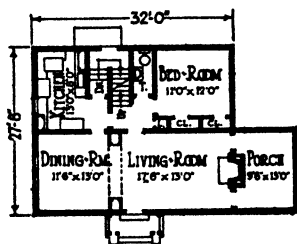

• FIRST FLOOR PLAN •

FIG. 8a.

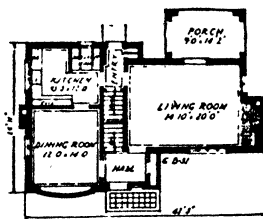
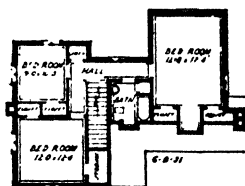
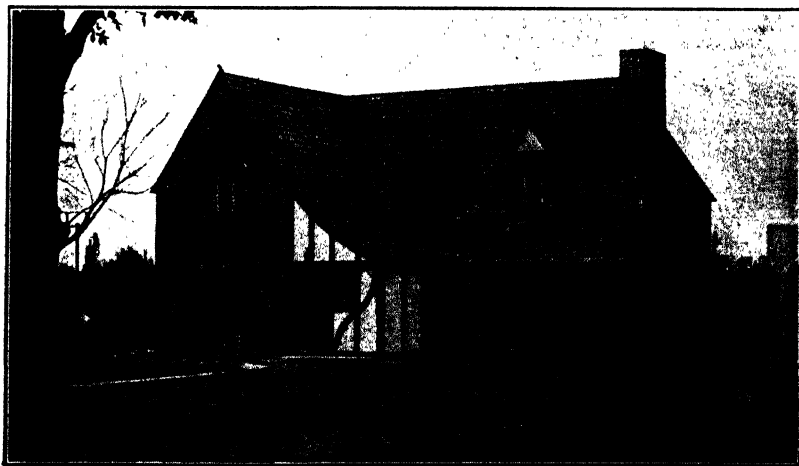

FIG. 9a.



Copyright. The Architects' Small House Service Bureau, Inc.
Plan No. 6-B-31

FIG. 9.

Figs. 5 to 9 Courtesy of American Builder and Building Age.



FIG. 10.

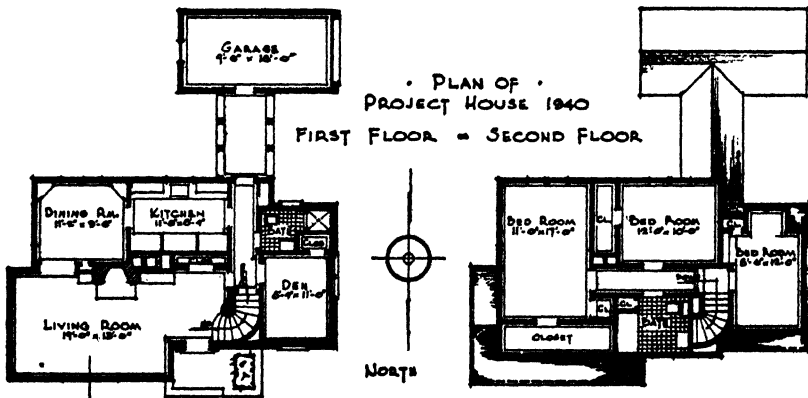

FIG. 10a.

Figs. 10 and 10a are printed by permission of Mr. E. J. Simon, Director of Industrial Arts of the Champaign City High School. This home was designed and built by the students in the industrial arts department of the Champaign High School, Champaign, Illinois.

UNIT XXXIII

PENCIL TRACINGS

PURPOSE OF UNIT XXXIII

It is the purpose of this unit to show how to make direct pencil tracings for blueprinting.

WHAT YOU SHOULD KNOW ABOUT PENCIL TRACINGS

The process of tracing a pencil drawing in ink requires considerable time because of the great care which must be exercised in the manipulation of ink instruments, and also because the tracing work must be frequently suspended to allow the ink to dry.

With the improvement of blueprint papers and blueprint machines it has become possible to make satisfactory blueprints from pencil tracings. Because of the greater speed with which these can be executed, many shops are using pencil drawings made directly upon tracing cloth or paper as the source of their blueprints. Although the blueprints thus obtained are not so clean-cut in appearance as those made from ink tracings, they may, nevertheless, be made of a quality quite satisfactory for shop purposes. The original pencil copy is also quite permanent if properly handled and filed away.

HOW TO MAKE DIRECT PENCIL TRACINGS

Technique of drawing in pencil only. In preparing a drawing of this kind directly upon tracing cloth or paper, first work out the outlines of the object lightly with a 4H pencil. Draw the lines lightly so as not to indent the paper. Follow the usual procedure in drawing the object and in placing the dimensions, etc.

After the exact limits of all lines have been thus worked

out carefully, erase the over-running lines and all lines used for construction only, so that no evidence of them may appear upon the blueprint.

Even though the drawing is now correct in all its details it is not yet ready for blueprinting, since the light pencil lines will not be sufficiently opaque to make good blueprints. Therefore, go over the entire drawing with a softer pencil, of about the grade F or H, to make all the lines a dense black. It should be noted that the quality of paper will have some effect upon the grade of pencil; in general, rough papers require harder pencils. Be careful to maintain a contrast between the three kinds of lines, visible, invisible and dimension lines. You will obtain this contrast by carefully controlling the shape of the pencil point. Make the visible outlines the heaviest by using a somewhat blunt and rounded pencil point instead of a sharp one. Exercise great care to make the visible outlines all of the same width. Rotate the pencil between the fingers slowly as the lines are drawn. This will prevent the wearing of a flat, broad point and will maintain a fairly uniform width of line. Occasionally dress the point upon the file or sandpaper.

Use a somewhat sharper point for the invisible lines and carefully maintain its sharpness while drawing these lines. For good square-ended dashes, bring the pencil to a full stop at the end of each dash, before lifting it from the paper to begin the next dash.

For cross-hatching, center lines and dimension lines, use the 2H pencil and keep it sharp by frequent dressing on file or sandpaper. Constantly rotate the pencil as you move it along the T-square or triangle in order to maintain a uniform width of line, regardless of the weight of the line. Make all lines, whether outlines or narrow dimension lines, as densely black as possible. To obtain the best results, hold the pencil nearly perpendicular to the paper and bear down harder than you usually do when making pencil drawings.

How to avoid smudging soft pencil lines. Exert sufficient pressure on the pencil to indent the tracing paper slightly

(this cannot be done as well with cloth). Not only will this make a firm line, but furthermore the pencil mark will be depressed below the rest of the sheet and therefore will not smudge so easily when the T-square or triangle passes over it. You should, of course, avoid, as much as possible, sliding triangles over the drawing. Pick them up to move them. Exert just a little downward pressure on the head of the T-square as you move it back and forth, to lift the blade from the paper. With precautions such as these, which will become habitual with practise, you will learn to produce a clean-cut pencil tracing.

To preserve the finished drawing. When such pencil drawings are to be frequently handled, to prevent smudging of the finished drawing, coat the surface of the paper with a special preparation made for this purpose which can be obtained from dealers in drawing supplies. This preparation can be brushed or sprayed on the drawing. Follow carefully the directions furnished by the manufacturer. Such preparations preserve the drawing, and still permit alterations to be made by erasure in the usual way.

QUESTIONS

1. Why are blueprints frequently made from pencil drawings?
2. Are blueprints from pencil drawings as clear-cut in character as blueprints from ink drawings?
3. What is the proper procedure in preparing pencil drawings for blueprinting?
4. How may contrast between outlines and dimension lines be obtained?
5. What grade of pencil should be used for finishing the drawing?
6. What effect does the texture of the paper have upon the selection of the grade of pencil?
7. Name three things that may be done to avoid smudging the drawing.
8. How may one avoid wearing a broad, flat spot on a soft pencil when ruling lines?
9. How is the pencil point maintained in condition so that it will produce a uniform width of line throughout any drawing?
10. Describe the proper method of drawing invisible lines.

PROBLEMS

Lay out the standard border line and title space upon a sheet of tracing paper. Make a finished pencil working drawing, directly upon the tracing paper, of an object assigned from the following group. Be sure to have a piece of heavy paper under your tracing paper so that your pencil will not punch through.

See to it that no over-running lines or construction lines, no matter how light, are left upon the finished drawing.

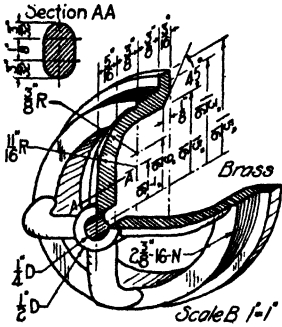

FIG. 1. Valve seat.

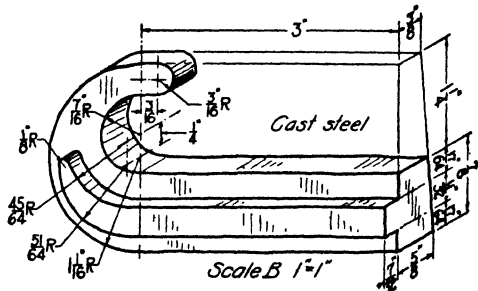

FIG. 2. Beam hook.

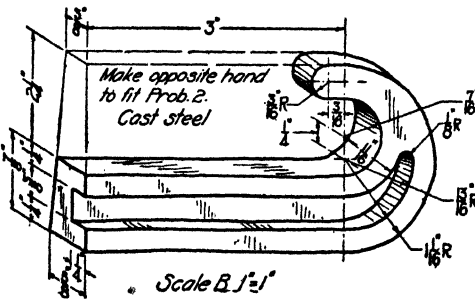

FIG. 3. Beam hook.

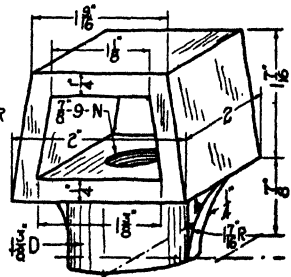

FIG. 4. Beam hook yoke.

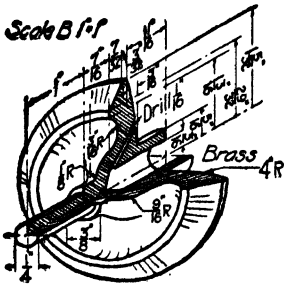

FIG. 5. Valve.

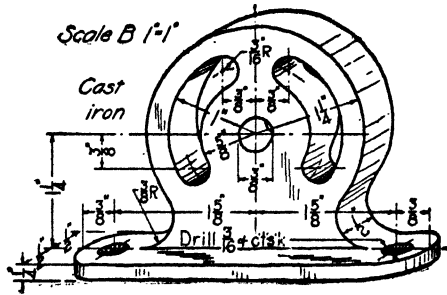

FIG. 6. Door check guide.

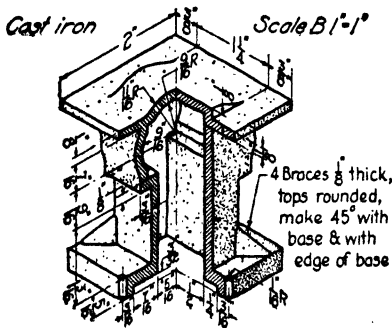

FIG. 7. Ceiling insert.

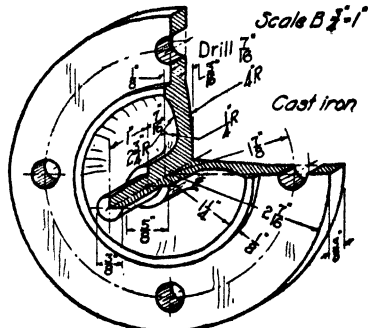

FIG. 8. Valve cap and guide.

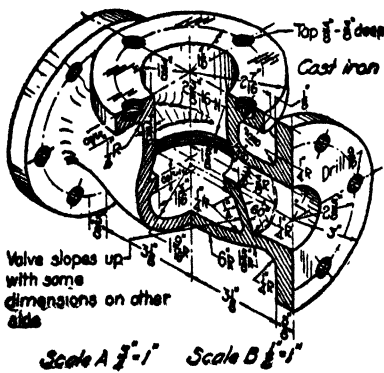

FIG. 9. Check valve body.

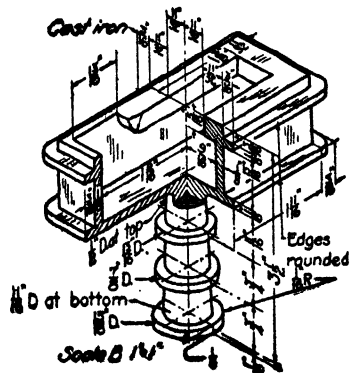

FIG. 10. Concrete insert for bolts.

UNIT XXXIV

BROWN OR SEPIA PRINTS

PURPOSE OF UNIT XXXIV

It is the purpose of this unit to show how to make and use sepia prints.

WHAT YOU SHOULD KNOW ABOUT SEPIA PRINTS

Good sepia prints, as the name implies, are deep brown in color. This paper like blueprint paper may be obtained in several weights and speeds. It is furnished to the trade under a variety of names, as: VanDyke Solar Paper, Brown Process Paper, Madero Paper, Sepia Solar Paper.

Sepia prints may be used in the same way and for the same purpose as blueprints, since they differ only in the color of the background. They are, however, more frequently used as negatives to obtain blue-line prints.

For the purpose of making blue-line prints a very thin grade of paper is used and a print is made from a tracing as described below. This print has white lines on an almost black background. By rubbing the paper with a "transparenting" oil the white lines of the drawing are made translucent while the background remains opaque.

This print may now be used like a tracing with ordinary blueprint paper. Since the light penetrates only the lines of the drawing, only the portion of the blueprint paper lying under the lines is changed, thus giving blue lines on a white background. Such prints are more desirable than ordinary blueprints for several reasons. First, they look more like the original drawing having dark lines on white background; second, pencil notes, changes, or corrections can very readily be added.

HOW TO MAKE A SEPIA PRINT

The process is essentially like that of making blueprints with one additional step. First, expose the sepia paper to light under the tracing which it is desired to reproduce. During this exposure a reduction process goes on in the sensitizing solution, which contains potassium sodium tartrate, citric acid, ferric oxalate and silver nitrate.

Determine the time of exposure by trial when using electric arc lights, and when it has once been determined, use it thereafter without variation for the same paper and light. Second, develop the paper by washing in water. Thus far the process is similar to that of making a blueprint. Next, wash the print in a fixing bath of hyposulphite of sodium (called hypo for short). Then rinse the print in water and hang it up to dry.

If the print is to be used for making blue-line prints, coat it with a "transparenting" oil and allow the oil to dry. This oil is furnished to the trade under several names such as Transparento, Peerless Transparenting-Solution and Translux.

When the sepia print is to be used only for making blue-line prints place the tracing upon the sepia paper with the ink lines in contact with the paper. (This is just the opposite position used in making blueprints.) This makes the print a negative in all respects, and when using it to make blue-line prints turn it in the same way over the blueprint paper. This scheme makes for a sharper definition of lines on the final print since there is always line-to-paper contact, thus allowing no diffusion of the light.

If a sepia print is over-exposed there is no method of restoring it as was the case with blueprints. An over-exposed sepia print must simply be discarded.

QUESTIONS

1. What is the color of the background of a sepia print?
2. What are sepia or brown prints used for?

3. Name the steps in making a print.
4. How does the making of a brown print differ from making a blueprint?
5. Why is thin paper usually used for making brown prints?
6. How must the brown print be prepared before it is used to make blue-line prints?
7. How may one determine the proper time of exposure for brown or sepia prints?
8. If the print is over-exposed, is there any method for improving it?

INDEX

- A.S.A., 209
- A.S.M.E., 199
- Auxiliary views, 177
- Azimuth, 242, 243

- Blueprinting, 156
 - equipment, 157, 158
 - history, 156
 - making of, 159, 160
 - paper, 157
- Bolts and nuts, 206
 - dimensions of, 207, 208
 - how to draw, 209, 210
 - how to specify, 210, 211
 - kinds, 207
 - use of, 206
- Building construction details, 252
 - common details, 255
 - cornices, 260, 262
 - dimensions, 264
 - doors, 258, 261, 269
 - fireplaces, 260, 263
 - footings, 257
 - how to draw, 263
 - interior trim, 261
 - lumber dimensions, 257
 - lumber grades, 257
 - sills, 258
 - stairs, 262
 - types of construction, 252
 - windows, 258, 259
 - wood framing, 255
- City plats, 238
- Contour lines, 240, 243

- Drawing sheets, 12
 - layout, 13
 - placing, 12
- Erasers, 2

- Geometric constructions, 33, 34, 35,
36, 50, 51, 52, 53, 161, 162, 163,
164, 165, 166, 167

- Herschel, Sir John, 156
- House floor plans, 268, 269
 - characteristics of, 272
 - compared to other drawing, 268
 - dimensioning, 273
 - drawing of, 275, 276, 277, 278
 - use of symbols, 268, 269
- House plans (complete), 287
 - complete set, 287
 - plot plans, 287
 - specifications, 287
 - use of detail drawings, 290

- Inking, 45
 - filling pen, 47
 - inks, 46
 - joining lines and arcs, 49
 - lines, 46
 - order of, 48
 - ruling lines, 47, 48
- Instruments, drawing, 29
 - use, 30, 31, 32, 33, 45, 47, 48, 49

- Lettering, 18
 - balancing, 58
 - forming, 22, 23, 24
 - inking, 25
 - instruments, 21
 - laying out, 59
 - legends, 58
 - maps, 246, 247
 - notes, 59
 - pens, 20, 21
 - rules for, 18, 19, 20
 - size and style, 59
 - spacing, 39, 40
 - titles, 57

- Maps, 236**
 azimuth, 242
 city plats, 238
 contour lines, 240, 243
 engineering, 238
 geographic, 236
 hachures, 240
 highway, 238
 how to draw, 242
 lettering, 246, 247
 profiles, 241, 245
 symbols, 238, 239, 240, 245
 topographic, 236, 237
- Numbers, 24**
- Orthographic projection, 62, 63**
 analysis of views, 90
 arrangement of planes, 66, 67, 68, 69
 choice of views, 85
 curved surfaces, 74, 76, 77
 ground line, 68, 91
 hidden lines, 73, 75, 76
 how to draw projections, 85, 86, 89, 91, 92, 93, 94
 how to make auxiliary views, 179, 180, 181, 182
 how to read projections, 173
 location of points, 169
 need of auxiliary views, 177
 point of sight, 65
 position of auxiliary plane, 178
 position of lines, 170, 171
 position of planes, 171, 172, 173
 principal planes, 64
 principles, of projection, 83, 85
 reading projections, 169
 solving problems with auxiliary planes, 185, 186, 187
 three views, 81, 82, 83
 use of auxiliary planes in shop drawing, 191, 193, 194
- Orthographic sketching, 135**
 how to make, 137, 139, 140
 how to study objects, 135, 136
 uses of, 135
- Pencils, 1**
 grades, 1
 sharpening, 5
 use, 6
- Pictorial sketching, 143**
 isometric, 143, 144, 145, 146, 147
 perspective, 143, 144
 uses of, 143
- Profile**
 map, 241, 245
 view, 82
- S.A.E., 199**
- Scales, 3**
 graduations, 5
 kinds, 4, 5
- Screw threads, 198**
 American (National) standard, 199, 200
 definitions, 198
 how to draw, 202, 203
 multiple threads, 200, 201
 noting, 203, 204
 right- and left-hand, 201, 202
 terms, 199
- Sectioning, 212**
 broken sections, 221, 222
 commercial practice, 225
 cross-hatching, 216
 distinguishing adjacent parts, 218
 full sections, 214
 half sections, 213
 how to make, 215
 invisible lines, 215
 need for, 212, 213
 offset sections, 221
 removed sections, 220
 representing materials, 219
 revolved sections, 219, 220
 solid cylinders, 225
 unsymmetrical parts, 226, 227
 webs, 226
 wheels, 226
 when to use, 215
- Sepia prints, 300**
 descriptions, 300
 how to make, 301

- Shop drawings, 230
dimensioning, 232, 233
order of procedure, 230, 233
selection of scale, 231
selection of views, 230
- Symbols, 201
bolt, 209
door, 269
electrical, 272
heating, 273
map, 238, 245
material, 270
plumbing, 271
ventilating, 273
window, 269
- Titles, layout, 14, 59
lettering, 57
- Topographic maps, 236, 237
- Tracing, 151
correcting, 154
inking on cloth, 152, 153
need for, 151
preserving pencil tracing, 297
- Tracing—(*Continued*)
technique of pencil tracing, 295,
296, 297
- Triangles, 2
kinds, 2
test of, 9
uses, 7
- T-squares, 2
test of, 7
use, 6
- Working drawing, 103
arrangement of dimensions, 106, 107
construction dimensioning, 115
dimensioning, 104
how to make dimensioned drawing,
110, 111
location dimensioning, 119
location of dimensions, 106
method of noting, 132
notes, 124, 125, 126, 127, 128, 129,
130
selection of dimensions, 121
size dimensioning, 116
specific and general notes, 131

