

Birla Central Library

PILANI (Jaipur State)

Engg. College Branch

Class No :- 745.51

Book No :- J 22C

Accession No :- 34297

REQUEST

IT IS EARNESTLY DESIRED THAT THE BOOK BE HANDLED WITH CARE AND BE NOT MARKED, UNDERLINED OR DISFIGURED IN ANY OTHER WAY, OTHERWISE IT WILL HAVE TO BE REPLACED OR PAID FOR BY THE BORROWER IN THE INTEREST OF THE LIBRARY.

CREATIVE WOODWORK



RIPPING •

Frontispiece

✓
CREATIVE WOODWORK
FOR STUDENTS & TEACHERS

BY
W. T. JAMES
—
AND
J. H. DIXON
^

LONDON
SIR ISAAC PITMAN & SONS, LTD.
PITMAN HOUSE, PARKER ST., KINGSWAY, W.C.2
BATH MELBOURNE SINGAPORE JOHANNESBURG

1947

PUBLISHED BY PITMAN

**THE TECHNOLOGY OF
WOODWORK AND METALWORK**

By **NORMAN R. ROGERS**, *Tutor in Technology for the
City and Guilds of London Institute Examinations, etc.*

Foolscap 4to, cloth gilt, 337 pp., illustrated. 15s. net.

HANDICRAFT WOODWORK

Drawing, Design, and Practical Work

By **A. L. KEEBLE**, F.Coll.H., *Lecturer on Cabinet Making
and Woodwork at the Municipal College of Technology and
Manual Training at Stranmillis Training College, Belfast.*

Size 9½ in. by 6½ in., cloth, 232 pp., illustrated. 7s. 6d. net.

WOODWORK DESIGN

By **E. H. ARNOLD**.

In foolscap 4to, cloth, 114 pp., illustrated. 6s. net.

Sir Isaac Pitman & Sons, Ltd. Parker Street, Kingsway, London. W.C.2

PREFACE

THIS book has been chopped out of the experience of two working teachers who have spent most of their lives in teaching handicrafts.

Students preparing for standard examinations and practitioners who for some reason have lost touch with modern developments should both find this volume useful. It is hoped that enough teaching method has been included to help the craftsman new to teaching and enough craft for the teacher new to the bench.

We are indebted to so many of our colleagues for practical sympathy that it is impossible to say "Thank you" here. Our special thanks are due to Mr. S. Taylor who fathered the venture, to the late Mr. Harry James who made some of the drawings, and to the Director of Education for Leeds, Mr. W. J. Bees, for permission to use certain matter.

The tool illustrations were kindly lent by Messrs. C. & J. Hampton, Ltd., the makers of "Record" tools.

The photographs in "The Best of its Kind" are reproduced by kind permission of Mr. P. Waals, of Chalford, Gloucestershire; Mr. Gordon Russell, Broadway, Worcestershire; Mr. Robert Thompson, Kilburn, Yorkshire; and the directors of the Victoria and Albert Museum.

W. T. J.

J. H. D.

CONTENTS

	PAGE
PREFACE	V
CHAPTER I	
HANDICRAFT IN SCHOOLS	I
A retrospect—Slojd—Joints—Freedom—Supply of teachers	
CHAPTER II	
SCHEMES OF WORK	6
Original work—Design—The article must be efficient—The material is wood—The tools are woodworking tools—Speed—Design and the boy—Sales	
CHAPTER III	
TEACHING METHODS	9
The labourer—The artisan—The artist—The unusual child—Standards—Aids—Discipline—The teacher's personality—School contacts—Novelty—Danger—Some difficulties—Standardized methods—Punishment—Common class-teaching faults—The dull and backward	
CHAPTER IV	
TOOL MANIPULATION	20
Drill—Marking—Self-criticism—The written word—Using the tools—Planing—Sawing—Gauging—Chiselling—Shooting—Grinding and sharpening	
CHAPTER V	
DRAWING	31
The three stages—School equipment—Lay-out and printing—Dimensions—Varieties of line	
CHAPTER VI	
RECORDS	36
Time sheet—Record card—Wall chart—Record book—Reports	
CHAPTER VII	
TESTS	38
Their function—Bench work—Drawing—Theory	

CHAPTER VIII		PAGE
MACHINES IN SCHOOL		41
CHAPTER IX		
JOINTING		42
Templets—When to joint—Jointing wide boards—Gluing		
CHAPTER X		
FINISHING		44
Oil—Water stain—Oil stain and scumbles—Dyes—Lime—Wax French polish—Paint—Chemicals		
CHAPTER XI		
RODS		47
CHAPTER XII		
“WHAT TO MAKE” SUGGESTIONS		50
CHAPTER XIII		
AN EXPERIMENT IN TESTING		51
Aim—The test—Marking—The ready reckoner—The findings: Speed and accuracy relationship—General school ability in comparison with tool handling ability—Secondary school boys in comparison with elementary school boys—Best elementary in comparison with average secondary boys—Good districts in comparison with slums— A school for deaf—A special school—Norms—Analysis of mistakes —Conclusions—Practical tests and vocational guidance		
CHAPTER XIV		
THE THREE STREAM SCHEME		75
Introduction—A joint—The table—Designs—Decoration and finish—Instruction methods—Planed wood—Timber—Sales— Mouldings—Nails—Advanced designs—Library—Illustrations— Taste—Templets—Reports—Time sheet—Record card—The drawings and the instructions for making the scheme		
CHAPTER XV		
DISCIPLINARY EXERCISES		107
Introduction—The drawings and instructions		

CHAPTER XVI

	PAGE
A SCHEME OF PLANE GEOMETRY	116
To bisect a line—Perpendiculars—Parallels—Angles as a measure of revolution—The circle—The tangent—Triangles—The right angled triangle—Quadrilaterals—Ratio and proportion—Polygons—“Touching” problems—Enlarging and reducing by squaring—Areas—Pythagoras theorem—The ellipse—Loci—Vector quantities—Centre of gravity by drawing—Tracing paper problems—Some approximate solutions	

• CHAPTER XVII

A SHORT COURSE OF SOLID GEOMETRY	120
--	-----

CHAPTER XVIII

A RULER DRAWING SCHEME	131
----------------------------------	-----

CHAPTER XIX

SIXTY-FIVE SIMPLE CABINET DESIGNS	143
---	-----

CHAPTER XX

EQUIPMENT	223
Introduction—Individual bench tools—General tools—Auxiliary tools	

APPENDIX I

BIBLIOGRAPHY	229
------------------------	-----

APPENDIX II

GLOSSARY OF TECHNICAL TERMS	232
---------------------------------------	-----

APPENDIX III

“THE BEST OF ITS KIND”—PHOTOGRAPHS OF ANCIENT AND MODERN CRAFT WORK IN WOOD	236
---	-----

INDEX	253
-----------------	-----

LIST OF PLATES

	<i>Frontispiece</i>	PAGE
Ripping		22
Planing		24
Use of tenon saw		24
Ripping		25
Use of coping saw		26
Gauging		27
Vertical chiselling		27
Horizontal chiselling	27,	28
Shooting (end grain)		29
Boring		29
Standard lines for drawing		32
Term tests		39
Skeleton book case		47
Rods		48
Templets		78
Printing		141
Boys' work		166
Stool in oak		171
Group work		190
Boys' work		192
Wall cabinet		212
Boys' work		219
Footstool and cakestand		220
Fourteenth century chest		237
Gate leg table		238
Glastonbury chair		239
Oak draw-table		240
Carved oak side-table		241
"Chippendale" chair		242
Pedestal desk		244
Walnut cabinet		245
Table and panelling		246
Reredos		246
Refectory table		247
Chancel screen		247
Oak fireplace with seats		248
Walnut cabinet on stand		249
An interior		250
Oak and ebony sideboard		251
Bedside cabinet in oak		252
Oak shaving mirror		252

CREATIVE WOODWORK

CHAPTER I

HANDICRAFT IN SCHOOLS

IF the aim of education is to fit the individual into the civilization of to-day, school handicraft has come to stay, for it is useful, cultural, disciplinary, and enjoyable.

Since man has always been a maker and a beautifier, all real crafts have histories and deep-rooted traditions. Because they have served, and still serve, the needs of life, their appeal is instinctive. There are no short cuts in a craft and, though some of the traditional processes at first appear to have no value, little true progress can be made without them. Any craft must therefore be approached through traditional channels, which include all the necessary safeguards.

Unintelligent people are easily satisfied with their own efforts and, unless outside standards are applied, rarely criticize them. The development of self-criticism in children is one of the teacher's greatest problems. Handicraft materials help, however, because faults are easy to see and may not be correctible. The work must either be accepted or reworked. Wood is almost an ideal educational material because of its humanity. Every sample is unique and behaves uniquely under the tool. Shape and texture vary, and present different problems at different times. These problems require intelligence for their solution; in humouring the material, resourcefulness is developed. The materials discipline the worker.

The untrained worker rarely makes anything useful or lovely because he lacks the organized knowledge, and habits, which would give him a plan of attack and the ability to execute it. Training in neatness and accuracy will develop purpose and vigilance. In addition, the habits acquired in the craft room have an everyday practical value.

Work at the bench also helps to build up a boy's physique and muscular control, and forms a useful addition to his physical training.

During the last twenty years, conditions have changed so much that it is now possible to do a day's work and enjoy an evening's amusement without having to stretch either mind or body. The bracing effort of active participation is not required by many of to-day's amusements. To see and to hear are sufficient. With the possibility of increased leisure in the future, the need for interests which require effort and concentration will become more urgent.

As the mechanization of industry proceeds, the school may soon be the only place where the true hand-craft spirit will be found, while from it may spring a race of amateur craftsmen to carry on the satisfying occupations of the past.

Taste and fashion do not always agree, for beyond the whims and vagaries of fashion lie standards of beauty which are almost absolute. This is not to say that cultivated taste does not alter, or vary, but articles of genuine artistic merit from any age will always have value. The appreciation of such standards is often innate, but as there is an intellectual bony structure inside the organism much can be done by training. There are definite rules for all arts and crafts, and these can be taught. A child learns to speak correctly mainly by imitation, and it will learn other correct standards in the same way. If behind the instruction there is a planned attempt to cultivate taste, a great deal can be done for children, even those coming from squalid surroundings. Most of us, if only partially, succumb to environment, and because of this, it should be our policy to give children as good a one as possible, together with the wish and the ability to improve it. To quote *The Teaching of English*, "We must offer to the young nothing which is not in some degree a work of art." Simple well-proportioned jobs on traditional lines will instinctively educate children.

Everything which compels the inclusion of music, art, and literature in the curriculum obliges us to put craftwork by their side. Together they help to correct what might otherwise be a rather narrow academic training, and form a cultural and moral group, the importance of which can hardly be over-estimated.

Retrospect. Thirty years have seen the work pass through several well-marked phases, so that to appreciate the modern attitude some knowledge of its history is desirable.

Slojd. The first organized impulse came from Sweden. This

had little spiritual relationship with English craftwork. The principal tools used were the axe, knife, bow saw, gouge, spoon iron, rasp, file and glasspaper. Artificial emphasis was laid on great adroitness with "folk tools" alien to this country. For the most part wood was regarded as something to be modelled, while its constructive possibilities were relatively neglected. Many of the "models" required wood which had been split with an axe, so that there was a good deal of waste. Birch or alder was used where our native choice would have been oak, elm or possibly walnut or ash. Abrasives occupied an unwarranted prominence. The schemes were quite rigid, and many of the articles were of little value except as laboriously completed museum pieces. The subject was at first presented by Swedes and their trainees who were usually craftsmen from the bench. The idea that a teacher of Slojd or Manual Instruction should have some general education or culture, other than his craft, had not then germinated. The instructor of that day was a school pariah who wore an apron, worked in his shirt sleeves, and went his devious, incomprehensible ways like a troglodyte, underground, without light, heat or ventilation. Originality or independence of thought was not encouraged in the ranks, formal courses being forced on whole communities. But in spite of prejudice and misunderstandings, splendid pioneer work was done. During its migration the original scheme lost much of its value, as it consisted of many articles of no particular use to English people. Dimensions were metric and had to be worked with English size tools so that awkwardnesses were common.

Protracted theory lessons were an alarming feature, for it was assumed that a child should learn about everything connected with the subject. Discourses on metallurgy, nature study, timber and tools consumed large assignments of time, and the spectacle of a hollow square of tired dispirited boys gathered round a teacher who was dutifully trying to hand-cram them with chunks from the encyclopedia, was common. Always the boys gazed wistfully at their bench work as their instincts clamoured for expression. Class teaching was customary, the same rate of progress being expected.

The drawing was usually neat and accurate, but consisted of little but copies of simple drawings, worked line by line from the blackboard. Intellectual effort was not required.

Joints. The next step was an attempt to found a school craft based on English practice. In this the City and Guilds of London Institute played a prominent part. As the most powerful examining body in the country its examinations eventually determined the courses worked by boys. With a sane insistence on sound constructional methods, it stressed the significance of joints. This method was, however, exaggerated in some quarters, and joints became a fetish. Joints divorced from structures, without interest except as ingenious craft puzzles, together with exercises of every imaginable shape poured forth. These harvests of curios were usually burned. The boy must sow but was not allowed to reap. Yet during this period the saw became recognized as the boy's most important tool. Compulsory schemes and over-prominent theory continued, while the drawing remained more or less unchanged.

It was now seen that any single scheme, however good, was insufficient for the varying needs of different schools, and alternative models came into being. These usually consisted of slight modifications of original exercises, incorporated in some other article. Elaborate tables were compiled showing all the tool exercises involved and setting out their gradations and stages. This inhuman dissection led to the making of much educational rubbish. Fancy flower sticks, plant and key labels led up to soap boxes and towel rollers. Of usefulness there was little, and of loveliness there was less; even stark functional beauty was wanting, for niggling additions and subtractions were made to complete the tale of exercises, regardless of their effect on the appearance of the finished article. This mistake was further emphasized by the small supply of timber which led to the packing of as many exercises as possible into the smallest quantity of wood which was usually soft wood or the softer hard woods.

Hitherto, most of the work had been left "in the white," but some attempts were now made to finish it properly. The correct finishes were not always used, the wood being often hidden by hideous stain and sticky varnish. Theory continued to be interminable and precious time was spent on unnecessary academic plane and solid geometry.

Freedom. Freedom and self-expression were the characteristics of the next development. The old schemes and forms of training

were discarded and advanced work was undertaken for which there had been no adequate preparation. The boys were casually introduced to the tools and materials, while the heuristic method was presumed to do the rest. Children often spent dreary months designing [*sic*] and making single articles. This was an age of wobbling tables, stools which inadvertently collapsed when sat upon, gaping joints, large nails and much putty. The article produced was lost sight of, for if it were the child's own creation the mental development involved was held to justify any practical deficiencies. It is questionable whether, even during this period, much of the work was really the child's own. Craftsmen outside the schools ridiculed this work which consequently fell into some disrepute.

The succeeding growth was the making of things combining both wood and metal, the latter being often derived from old food tins. This hybrid had a short life for it combined the weaknesses of both its parents. The articles made were, as a rule, both ugly and useless. Even so, this movement originated light metalwork schemes, worked with a minimum of equipment, which are turning out sound artistic work to-day.

About this time much was heard of correlation, and handwork as an aid to other school subjects. The ingenuity of many of the schemes is not open to question but correlation became a rage and a fad. The natural lines of the work disappeared and the practical use of books gave place to the unpractical use of tools. Much of the crudity was, however, soon laughed out of court.

Supply of Teachers. After the War the problem of the supply of qualified men became acute, for the normal class-teacher's experience in handwork was as a rule very limited while the supply of craftsmen from the bench almost dried up. Great difficulty was experienced in filling an ever-increasing number of vacancies caused by the universal expansion of the subject. Men of sound education with a flair for craftwork were needed. Intensive short courses were resorted to, and the training colleges were encouraged to develop the craft side. To-day there is a good supply of men from these sources, and, in addition, there seems to be a movement to get craftsmen from the bench back into the schools.

CHAPTER II

SCHEMES OF WORK

A SCHEME should make ever-increasing demands upon ability. Since a boy works at his maximum efficiency when all his available energy is being absorbed, each stage should be within his powers but only just within. Too easy a task will encourage slackness and retard his development, while if the problems are too hard he will be discouraged, for he feels that satisfactory progress is beyond him. He needs simple, well-graded, beautifully-worked exercises to stimulate him. What a boy can do well he will enjoy, and this fact should be used to develop interest and establish confidence and self-respect.

Original Work. If we require originality from pupils before they are competent, the consequences cannot be satisfactory. Original work requires a positive original mind, sufficient experience of tools, processes and materials to create a design, and enough skill to make it.

Positive original minds are rare. Fine form is usually the spontaneous expression of technique and ideas which have become part of the make-up of the designer, so that to demand originality from the pupil before his experience is adequate, is to court failure and disappointment. The boy must be given good designs and encouraged to modify them before attempting more ambitious flights. No approach to beauty or morality can be made through ambitious shoddy.

DESIGN

When considering the suitability of a design for inclusion in a scheme, always remember the following points.

The Article must be Efficient. It should be strong but not clumsy. It must be stable, handy, and neat, and should be the right size. Moving parts should move easily and be made of hard wood which will not warp. They should be strong and durable. Glued joints should never be included where they will be exposed to the weather or to continual damp or heat. There should be no useless

appendages included because of their alleged decorative or educational value.

The Material is Wood which has a range of uses outside which it fails. The grain must never be forgotten. Curves should be gentle and there should be no sharp exterior angles. The joints should be so arranged that the natural stresses of the structure will tend to tighten them. They should strengthen the article. The design will usually be rectangular and the grain run the long way of the members. Deep carving or fretwork is frail and gathers dust. There should be no attempt to imitate designs for metal or stone, but every opportunity should be taken for insisting on the beauty of the grain. Emphasis must be laid on colour and proportion, so that designs will as a rule be simple. Elaborate designs are rarely good.

The Tools Used are Woodworking Tools, and the design must be made with them. Since hand tools change but slowly, a study of traditional work will reveal the fundamental type of design. The simpler examples of period work from the Gothic to that of to-day are valuable for school modification. The methods of construction, the interlacing strapwork, simple gouge cuts, and geometrical inlays require few extra tools and are within the capacity of most boys who appear to be spiritually *en rapport* with them. Much modern furniture is strongly reminiscent of antique work in its insistence on good proportion, its sound simple construction and decoration.

Speed is Vital, so that early exercises should be brief. Too much time spent on any one exercise breeds indifference.

Designs can often be culled from good catalogues, and from the South Kensington Museum picture books and post cards. They often need drastic modification, however, before they can be used in school.

Design and the Boy. A boy's reaction to design is emphatic. He defines things by their use and his first question is usually "What use is it?" A useful thing is intrinsically interesting to him and secures his attention. Attention means learning. Toys are only of passing interest and do not secure his attention as do "real" things.

At the end of the formal scheme the stage is reached when the boy can really try his hand at designing. The teacher has now a severe task. This is to suggest enough amendments to make the

idea sound and workable without discouraging the lad. The master must see that material and energy are not wasted because of poverty in the conception. This calls for tact, knowledge, and courage. If the teacher and his scholars are on good terms there will be no loss of dignity on either side.

The schemes in this book can be recommended for elementary or secondary schools.

“**Sales.**” The shortage of timber supplies can be partially overcome by the adoption of some form of “sales” account by which the boy can pay for some proportion of the wood he uses.

CHAPTER III

TEACHING METHODS

THE worker can roughly be divided into three grades, the labourer, the artisan, and the artist. They correspond to the routine, scientific and creative stages of education.

The Labourer possesses automatic skill with simple tools. There is little reward in his work, which is done solely for the sake of a wage. In the training of children this is a time for routine and for drill.

The scholar does not worry about principles, his chief interest being to get the work well done. Reasons should be given as they are required but there should be little talk and much practice. Much of the explanation given to children passes over their heads because it is beyond their experience. At first, intelligent imitation should be the method. This is the time to form correct habits in measuring, sawing, planing, and chiselling and for making them automatic. If a child does not know his tables he will calculate poorly. If in adding a column of figures he has to stop to think, the result is less likely to be correct than if the process were a smooth mechanical one. To pause, because a word cannot be spelt correctly without reflection, is to interrupt the flow of ideas. Similarly, simple tool manipulation must be both automatic and accurate or little headway will be made. In the beginning, technique should be an end in itself. The boy will accept drill because the work is new, because it gives him a sense of power, and because he sees that it will be useful in the future.

The Artisan has added to the simple dexterity of the labourer higher skills requiring intelligence for their application. He can make experiments with good hopes of success. The stage of intelligent imitation has yielded to that of scientific experiment. There are now compensations in the work because the whole of a process is usually worked. This adds variety and interest.

The above holds good for the corresponding stage in education. The lad can rely upon his tool handling skill, and because of this can make individual experiments. Some appreciation of fine form is

now evident and the cultural side comes into prominence. During this period a boy should be planning his own routine and exercising his taste by selecting and modifying standard designs.

The Artist has skill *in excelsis* allied to definite originality and cultivated taste. He expresses himself in things of fitness and beauty. The work, which during the surge and turmoil of creation may become an obsession, is its own reward.

Whether the world would be a possible place to live in if most of our scholars became artists need not detain us here, but they must be steered along this path as far as possible. They must be trained to explore and develop their inborn talents. Although few can attain real eminence in a craft, they can originate work which will always be a joy to them. Moreover, during the making, they will have added cubits to their stature.

The Unusual Child. Children of outstanding ability are not always recognized in the schools, for their unique make-up may not fit into the school structure, while their development may occur during the stress of late adolescence. Real originality is scarce, but if it coincides with the spirit of the times is eagerly pursued and highly paid.

Standards. The teacher's first consideration must be to set high standards. He should, by example, give his boys something inspiring with which to compare their own efforts.

He should work examples while the lads watch and ask questions. Their attention should be drawn not only to the method, but to the speed of working and the accuracy of the result. After this they should imitate and should not be allowed to make too many mistakes, or they will eventually become disgusted and wearily abandon all efforts to make a good job. Tool drill will usually avert such crises, or, if they arise, remedy them.

The quality of the work should be substantially that of the teacher, but more time will be needed by the pupils. If most of them cannot work any exercise accurately, it is beyond them and should be simplified.

Before passing work the teacher should be sure that it is the boy's best. Whether it should be reworked is a matter for careful thought, for while too long spent on one piece of work kills interest, so does inaccuracy and poor finish. Mistakes must be referred to

their causes—indifference, lack of skill, poor teaching, and so on—which will determine the proper treatment.

Aids. A permanent exhibit of outstanding craftsmanship and pictures of craftsmanship can be relied on to educate both skill and appreciation. Dirty ill-designed work should be banished, for it suggests that poor stuff is good enough.

A photograph album is useful. To get his signed photograph in the "Honours Book" is an incentive to a boy and a reward for his efforts. Such a book shows the teacher what progress has been made in the department.

Standards unconsciously set by the teacher are those of speech, manner, and attitude of mind. Children are copyists and much information can be gleaned about the teacher by observing his class. The room should be clean and orderly, while tools and materials should rarely be to seek.

Discipline. Enjoyable and effective teaching demands sound discipline. Little good work can be done in an atmosphere of boredom or unrest. Poor work, excessive noise, dirt, and untidiness all bear the stamp of weak discipline. Children soon sense lack of control or indecisiveness, and are ingenious in practising old tortures and inventing new ones. In school great differences in both intellect and temperament are found, and while every problem must be settled on its merits, certain broad principles will help us to organize the work successfully.

The Teacher's Personality. Enthusiasm and virility in a teacher are contagious. Amazing results can be produced by those who believe in children, and in their own job, and bring to bear on them a dynamic personality. A lukewarm teacher will get only mediocre work.

If the master has a clear pleasant voice he is well endowed, for a harsh grating voice soon puts children on edge besides giving the class mimic plenty of scope. Any strain under which he is labouring will show in his voice, which will faithfully reflect it. Complete relaxation allied to quiet alertness should be aimed at. The voice should have plenty of breath behind it while the throat muscles should be slack and easy. The teacher's manner may make or mar his work.

As victory usually falls to the more even-tempered, a sense of humour and cheerfulness are invaluable. Laughing children can be

led up many a stony path. If they are "on your side" they will work for you. Children are quick to note and to resent stupidity or injustice, and any obsession under which a teacher labours will warp his judgment and frustrate his efforts by antagonizing his class. Should he find a large number of "criminals" amongst his boys the fault is his, and he should take stock of himself to find the cause. Discipleship should be the goal, not dictatorship. Authority does not thrive on over-work. A too rigid discipline causes more crime than it cures.

Child Study. Instincts are often more compelling than reason. When we have found what boys like we shall be in a strong strategic position. Children and adults alike live very largely in their emotions.

The instinct to make is, with boys, a mighty force. From earliest days they must be doing something—lawful or unlawful. This impulse must be harnessed and made productive. If they are kept busy, they will be happy, particularly if they are making beautiful, useful things. They like to give presents to those they admire and love. These presents can be made in the school workshop.

Children are curious and interested in novelty so that the fare we offer them must be varied and attractive. It should be different from their staple diet and should whet their appetite for more.

To appeal to the sporting instincts of boys is sound teaching practice. Speed contests and team events stir up emulation. Pleasant rivalry should be encouraged and the boys should be allowed to criticize each other's work occasionally. This criticism should not be mere fault finding but should stress the good points.

What a child can do well it will enjoy. Difficulties must, little by little, be added to what can be done. This will give confidence to attack difficult work and a sense of power will be developed.

Undesirable emotions such as sulkiness and bad temper must be weakened by giving them no opportunity for expression. This calls for a close study of the individual child. Children cannot be taught in the mass. There is no loss of dignity in studying particular children for they are the teacher's material, and a good workman will always study that. If a boy is a natural leader, make him into a shop foreman. If he is timid and lacking in self-confidence, he needs a leader, and needs constant encouragement to take the lead in some activity, however modest. Should he be aggressive and

stubborn, advise him not to be beaten by his tools and his wood. A boy who lacks will power or self-control should be shown that he will need them. A spoiled child must be taught that the world does not revolve around him, and shown that he is neither more nor less important than the other lads. Should a temperamental outbreak occur, its cause must be found and the proper remedies applied. Generally, a boy needs plenty of encouragement. The teacher's control should be firm but kindly. Every help should be given to a lad in finding his strength. He must be made to feel important and clever. During the process, the teacher will find the real boy who is more significant than the subject.

School Contacts. It is a good plan to know each scholar by name, temperament and home circumstances, and to keep a record of his outstanding traits. In a large centre this is a counsel of perfection, for it may be difficult to attach a face to a name. The handicraft teacher may never get to know his boys and, unless school contacts can be made, he is bound to remain very ignorant of them. The assistant and head teachers of the contributory schools should be invited and welcomed to the centre, and if the handicraft teacher can get himself invited to the school staff meetings, so much the better. Because of its isolation the centre system is doomed.

Novelty. The unfamiliarity of the craft room will usually be a great help. The teachers, materials, and tools are novel, while the difference between sitting in a desk and working at a bench is striking. The freshness of everything is stimulating. The boys are again toeing the same mark and there is no traditional millstone round any not over-strong neck. All have a chance of making good. Every advantage should be taken of this situation and the work should start with a bang and continue with a whizz.

Danger. The woodwork teacher cannot keep the whole of the class in his eye as the class teacher can. Much of the work has to be done behind his back with tools which are dangerous if mis-handled. The incessant background of workshop noise, under cover of which irregularities are fairly easy to commit, compels constant alertness. The teacher needs sharp eyes, keen ears, and unsleeping vigilance. "Larking" or unsafe tool manipulation must be peremptorily stopped and vigorous cautionary instruction given. If this is ignored, to make the culprit stop work for a time or to exclude him

for a couple of visits is usually sufficient. The aim should be to keep the lads so absorbed that they have neither time nor inclination to get into mischief.

Some Difficulties. Order is always difficult to maintain when children are bored so that, wherever it is possible, listening should alternate with doing. This will break the lessons into digestible pieces. A queue of idle fidgety boys waiting to have their work attended to, or waiting for the next demonstration, should be avoided. The oral instruction should be terse so that it is easy to remember, and wastes no time. Oral or written assignments of work should correspond to the skill and intelligence of the children to whom they are given. They should increase in scope and leave more and more details to the boy. The giving of precise instructions should gradually change into asking a pupil for *his* plans. This, incidentally, is good training in oral English.

One of the commonest and greatest difficulties of the young teacher is that of keeping the whole class in mind. To teach a few boys, or most of the boys, is not sufficient. They must all get a reasonable share. If the thrusters and fussers only are attended to, the slackers will either make themselves invisible, or will create trouble. The whole of the class must be on the threshold of the teacher's consciousness.

Standardized Methods. There should be a recognized way of doing every job. This is both a technical and a disciplinary matter. Alternative methods, especially at first, are confusing and, if allowed, the lads will often try to play off one teacher against another. When all the boys are doing the same thing in the same way their transfer from one class to another in the centre is easy. They have nothing to unlearn, and both boy and teacher know exactly where they are. This makes for efficiency.

Punishment. No doubt in a better world rewards and punishments will be unnecessary, but it is doubtful whether they can yet be discarded in this. Human nature has changed little during historical times and may change little in the near future. It has always needed spiritual stimulants and correctives and possibly always will. The school reflects society and is no exception to this state of affairs.

Grave school misdemeanours, such as foul language, indecency, persistent theft, and the like, are difficult to handle because the

culprits are not always amenable to the usual school treatment. Other children have to be protected and warned that such offences are serious. If corporal punishment is considered to be necessary, it must be administered promptly and firmly; but, in general, its incidence will be in inverse proportion to the teacher's ability. It is more useful as a reserve which the boy knows can be thrown into the line if need be. When such punishment is given the reserves are spent so that its usefulness depends upon its infrequency. If punishment of any kind has to be administered, care should be taken that the teacher has the class with him or the weapon may be turned against him. Some natures have a genius for martyrdom and have developed the nursing of grievances to a fine art. Such will be a rallying point for all the rebellious forces in the class and a potential storm centre. This problem should never be given a chance of rearing its head.

A child must never be punished in anger. Loss of temper means a temporary absence of a sense of proportion without which neither justice nor charity is likely.

An offence having been punished should be expunged.

All the work should be forged into a disciplinary tool of the first order. If high standards of work are maintained good conduct usually follows. Sentiment lies behind most good work so that discipline is largely an emotional matter. Love, of person or pursuit, creates a desire to excel. The emotional appeal can never be neglected because it is the basis of all a child's effort and interest.

Good discipline is built upon control and willing co-operation. Its signs are an eager, alert, responsive class.

Naturally good teachers sense most of what has been said for they are sensitive to impressions and their reactions are strong and sympathetic. They do not play the high-handed autocrat nor do they truckle for popularity.

Common Class Teaching Faults—

1. Too much talking by the teacher; not enough talking and doing by the boys.

(a) Discussing lesson instead of getting on with it.

(b) Discussing possible but unlikely faults.

(c) Constant calling for order—a sign of weakness. Order should be assumed.

(d) Side tracking due to indefiniteness of aim, lack of clear thinking, ignorance, or imperfect lesson preparation.

2. Poor questioning producing thoughtless answers.

(a) Not enough why and how questions.

(b) Direct questions—"Is this silver grain?"

(c) Dilemma questions—"Is this oak or ash?"

(d) Leading questions—"This is a dovetail joint isn't it?"

(e) Elliptical questions—"We can tell oak by its ——?"

(f) Questioning only a small section of the class.

(g) Wasting time by asking pointless questions and talking too much.

(h) Wasting time by repeating questions and answers. This encourages inattention and confuses children who are thinking.

3. Slow tempo due to—

(a) Teacher's mental and physical attitude: lounging, continual sitting, drawling, hesitation, lack of vigour and alertness.

(b) Teacher talks too much or talks above children's heads.

(c) Lack of enthusiasm or interest.

4. Inaudibility, over-loudness or harshness of voice or manner.

5. Teacher's egotism.

(a) Boys not allowed to express their own opinion.

(b) The superior or humourless teacher.

6. Frightening the pupils.

7. Poor oral or blackboard English.

The Dull and Backward. No treatise on school method would be complete without some reference to the boys who, though not feeble-minded, are two or more years retarded. They form about 10 per cent of the school population, and may be backward because they are dull, because they have missed some part of their school life, or because they have been mishandled. They are the teacher's opportunity, for upon them he can sharpen the tools of his teaching technique and demonstrate his skill.

"Lazy" boys often spend considerable time at the school clinic

or attending the hospital. Their inertia is probably due to an attempt by their nervous organization to resist overstrain. Over-stimulation exhausts them. Luckily their numbers are few and they are easily recognized. Some parents unwittingly hold their children back by enlarging on their ailments when they are present, and give the lads a sense of interesting inferiority and a disinclination to exert themselves. If these lads are fit to work, they must be urged to work hard so as to do as well as the next fellow.

If a boy is physically weak he should make only small articles out of soft wood until he is stronger.

The real problem is that of the incurious, easily satisfied, and mentally inert. Somehow they have to be stimulated to vigorous effort and their critical faculty spurred into activity. Special efforts must be made to interest them. Interest makes the difficult easy. The "C" section of the Three Stream Scheme will adequately deal with most of these boys, but, if necessary, it should be unhesitatingly scrapped in favour of some individual project. If one can find any single thing in which they are interested, that must be the starting point. In every case the instruction will depend upon what is wrong, and that has first to be discovered.

Lack of dexterity calls for simple, easily-graded, carefully-supervised work with a great deal of tool drill and repetitive detail.

Some boys have difficulty in following oral or written instructions. This may be due to poor immediate or long distance memory, auditory or otherwise, or to poor powers of comprehension.

A weak memory needs brief instructions, frequently repeated by scholar and teacher until they are known. The teacher should ask plenty of what, where, and when questions. The simple routine instruction cards may be memorized and tested by oral questions.

Where comprehension is poor, the instructions should at first be brief but should get longer and fuller. A careful question or two will show whether they have been understood. The boy should repeat instructions in his own words and then work them out at the bench. He should never start a job until the teacher is sure that he understands what he is to do.

Poor reasoning power is responsible for much unsatisfactory work. The boy tackles every job as though it were his first. He does not realize that certain methods can be applied to all his work. He

blunders along and, even when a neighbour is doing a similar job, may not realize that all he has to do is to copy. On the other hand, he may copy some method which does not apply to his case. He cannot reason by analogy. He will make a notch correctly and exactly when instructed step by step by his teacher, but when left to himself will cheerfully try to chisel the next without using the saw. Such a boy must always be questioned as to his next step and encouraged to plan his work ahead, however short the distance. He must be asked many how and why questions, and should be referred back to previous jobs and methods.

Such a boy may never get beyond the routine stage, but it is poor teaching to assume it as a fact. He must be given a good stock of craft habits and encouraged to select the most suitable for his purpose. If we cannot give him reasoning power we must at least make sure that he uses what he has.

The boy whose *morale* has been destroyed or who has no initiative should be stimulated to individual effort. Even when his work is only fair, it should be regarded as promising. He must be helped to take a pride in unsupervised individual effort. He must be made to see that past failure is no reason for future failure. Drill and simple repetition work will give him a solid foundation of self-confidence. He can with advantage use the instruction cards and should do as much as possible without help. Often a communal job, by relieving him of much personal responsibility, will help. The comradeship of his fellow workers will help to give him confidence. He becomes part of an organized body and the importance of the work reflects his own importance. Once he finds that he can really do something, confidence begins to return, so that he must be encouraged unceasingly. Here again the boy should plan his own routine as far as possible.

If a boy visualizes poorly, or cannot deal with such abstractions as symbols and geometrical conventions, the ordinary orthographic projection will mean very little to him. If this is suspected, a few questions about a simple drawing will quickly reveal the extent of the trouble.

Such a boy may begin by working from a pictorial projection supplied to him, or, if this is too difficult, from a pictorial drawing and a concrete object together so that he can make comparisons.

Careful questions should soon put him on the right track. At the start he may have to copy other drawings, but as soon as possible he should start hand-sketching and drawing from the object with instruments. The object should then be made from his drawing. Drawings containing both orthographic and pictorial detail may be used until the latter, which are easy to understand but difficult to make, can be discarded.

Some almost feeble-minded boys may never seem to understand a drawing and may remain very hazy about measurements. These lads must work from the object.

Backward boys sometimes conceal under an apathetic exterior a warm emotional nature, and if their friendship can be won, and kept, a great deal may be done with them. If children dislike their teacher their antipathy is extended to the subject he teaches. The reverse of this is also true.

CHAPTER IV

TOOL MANIPULATION

IF a boy attempts technical work beyond his capacity, his failure lowers his *morale* and checks his progress. Ambitious work demands accurate unthinking tool manipulation.

Drill. Research and experience have proved that drill is a sure way of getting accuracy and speed, and there should be no hesitation in employing it. If it is intelligently undertaken, the necessity for working an exercise more than once does not often arise, because the drill has established both self-confidence and manual dexterity.

One kind of boy is interested in processes, while the other is mainly attracted by results. The first will almost teach himself. The other will only do spade work willingly if he sees the use of it. When drill is undertaken as a preparation for some impending difficulty, drudgery disappears because the boy can see the need for it. After a few lessons he is usually glad to ask for, and accept, skilled guidance. If he ignores the instruction, one of the best ways of dealing with him is to insist on him doing without it for a time.

Drill can be introduced in two ways. A disciplinary course of joints and other exercises may be worked or the drill may proceed with the making of small pieces of furniture, the exercises being interspersed between them. Both methods are illustrated in this book. Special drill is needed for special jobs.

The routine preparation of wood for jointing should be memorized. If typed instructions are displayed round the room the lads can be referred to them. As soon as they can discard them they will do so automatically.

The first exercises should be made of soft easily-worked stuff. Harder wood will be used for the more advanced examples.

Each new process should be introduced in a demonstration. The children should be asked to note the position of hands, feet, etc., and questioned as to why these are the best. A short running commentary should accompany each demonstration, after which the children should imitate. Before they actually operate on the wood the teacher should check each child's position at the bench. Boys

with special defects should have separate demonstrations and individual drill exercises. Small steps must be taken at first. These must be carefully checked. The standard of accuracy should be high enough to maintain keenness, but should not be so high that the pupils are discouraged. The tool technique should be that of the shop, modified to allow for lack of skill and strength. It should be entirely free from avoidable risk, and cuts or abrasions extremely rare. The boys are beginners, so that only the safest methods should be used.

Marking. If a system of marks is used, the finished work must be very carefully marked. Over-marking leaves the boy apparently little to strive for, tempts him to do poor work, and lowers the teacher's prestige. Under-marking discourages the lad. Marks should be awarded when a boy tries hard even if the work is not first class. Such work can be stamped with a rubber stamp "Improving." Good marking is a useful instrument, but it must be good.

Self-criticism. Poor work is often not due to poor tooling but to lack of self-criticism. It is sound policy to require the boys to ask themselves two questions: "What is wrong?" and "How can I make it right?" The teacher should rarely indicate either fault or remedy until it is clear that the lad has no ideas on the matter. If he expects a catechism he is thrown back on his own resources and trained to think. The attitude "Will it do?" changes to the better "Is it correct?"

Poor work is often due to poor testing, the value of which boys do not always realize, but until they can diagnose faults intelligent progress is impossible. Training to find and rectify blunders must be pursued until it has become etched into the mind. The natural testing tools are the eyes and the fingers, and mechanical aids such as the rule and square should be regarded as useful, but not essential, accessories. Within a very few months a lad should be able to say whether a thing is flat, square, parallel, or out of winding, without using anything but his eyes. His finger-tips should become so sensitive that they will be as good as an extra pair of eyes.

The Written Word. Many people cannot work to written instructions. To give practice in this, certain models and drawings should be made by the boys working from instruction cards. Routine jobs

such as polishing, grinding, and sharpening should be printed on cards and used regularly. Problems in design and new technique can be similarly treated. This device aids intelligent reading and self-reliance.

The practical work can be made more interesting if self-explanatory graphs showing individual progress are conspicuously hung on the walls.



PLANING

Using the Tools.

The correct use of the plane, gauge, saw, and chisel must be taught from the first. If wrong methods or wrong tools are used at the beginning, the proper technique will be delayed and, indeed, may never be acquired. To spend time in drilling the fundamental tools is true economy.

As in all games where powerful controlled strokes are needed, the legs must be wide apart to give grip and balance.

The body and leg muscles besides being stronger are easier to control, therefore at the start the hands should be regarded merely as tool holders while the body does the guiding and the pushing. In all tooling the feet and body should be so placed that all available strength is applied decisively along the line of the stroke. As arms and wrists strengthen they will naturally be used more. It is unwise to allow a beginner to make too many mistakes. A new piece of wood should be given to him and his action carefully watched and corrected. Coaching is as profitable in the workshop as it is on the playing field.

Planing. The photograph shows a good position. Most boys try to hold the plane down and push it forward, solely with the right hand and use the left merely as a guide. If the left elbow be held vertically above the left hand enough pressure can be applied to the toe of the plane to counteract this tendency.

Another boyish fault is to stand too far away from the wood with feet together. The plane is then swung with a round-arm motion with little control or economy of effort.

To accelerate the work it is a good plan to ask the boys how long it will take them to plane each surface and to compare their estimate with their performance.

INSTRUCTION CARD

1. Pick the better broad side for face side and plane it true. Test with eyes, fingers, and steel rule. Mark it with face side mark thus ∞ , the tail of the mark showing the way of the grain.

2. Plane face edge square with face side. Test with eyes, fingers, and try square. Mark it with face edge mark thus \surd .

3. Set the gauge to $\frac{1}{16}$ in. more than the width. Gauge the width, rubbing the fence of the gauge against the face edge. (The line should go all the way round the wood.) Plane to middle of gauge line and test.

4. Set the gauge to $\frac{1}{16}$ in. more than the thickness. Gauge thickness, rubbing the fence against the face side. Plane to middle of line and test.

Note. Beginners must show their work at the end of every stage.

SUGGESTED WALL POSTER

FACE SIDE

FACE EDGE

WIDTH

THICKNESS

The letters should be large enough to be easily read from any part of the room.

Sawing. The ability to use the saw is the measure of the craftsman's skill. Wherever possible, all joints should be left from the saw because the rough surfaces bed well together and form a key for

the glue. In the beginning, a boy will often use any tool but the saw for jointing. He may saw some distance from the line and finish with the chisel. This is wrong, of course. He must learn to saw lightly and smoothly with the whole length of the tool, keeping his eye on the line until the kerf is completed. Short fussy jabs are useless. Until a boy is expert he should not use both hands. The bow saw



USE OF TENON SAW
(Left-handed Boy)



RIPPING (VERTICAL)

is an exception. The heavy rip saw with its large teeth may require more strength to push through the wood than the boy possesses. The hand saw is a good alternative, while the panel saw can be used for thinner material. The full size tenon saw is also too big for most boys. Theoretically, the tension saws—bow and coping—should have their teeth pointing towards the handle. Practically, there is little to be said for it. The boys are used to pushing their tools and find the reverse process difficult. Also, as the teeth come through the wood, the short splinters hide the line. The coping saw is more useful than the bow saw in the school workshop because it is handier. A common mistake is to saw the wood while it is edgeway up in the

vice with the grain parallel to the bench top. The timber is easy to split while in this position and a small initial error makes a big final mistake.

Boys like to saw with the tool held at curious angles but are rarely successful because their sense of angular direction is not yet developed. The line to be sawn should be as nearly vertical



USE OF COPING SAW

as possible so that the centre of gravity of the saw is directly above its edge.

INSTRUCTION CARD

1. When making a joint, always saw touching the wastewood side of the line.
2. Saw slowly and lightly. Do not jab.
3. Keep your eye on the line.

Gauging. Little real headway can be made until the gauge can be used. It is an awkward tool for beginners, but if the use of the rule is allowed instead, the habit so formed will be a permanent nuisance. Some teachers gauge the first exercises for the lads, but the better method is to spend plenty of time in instruction and drill.

No boy should be allowed to gauge a line until he can slide the tool confidently from end to end of the wood without making a mark. If a stiff wrist is maintained, or too much pressure used, the last two or three inches of the line will seldom be satisfactory.

The worst fault is digging the point into the wood. This can be avoided by trailing the point, castor fashion. The correct line will be thin, and will not follow the grain. Scrap wood is useful for practice.



GAUGING

Boys' size gauges are now to be had, some of which have graduated stems. These are to be preferred, as the ordinary size is a big fistful for a boy.

INSTRUCTION CARD

1. Hold the gauge lightly.
2. Trail the point.
3. Gauge only from the face side or face edge.

Chiselling. This is probably the easiest exercise and also the most dangerous. The golden rule "Both hands behind the chisel edge" must be enforced.

The stance should be that for planing and sawing. The right

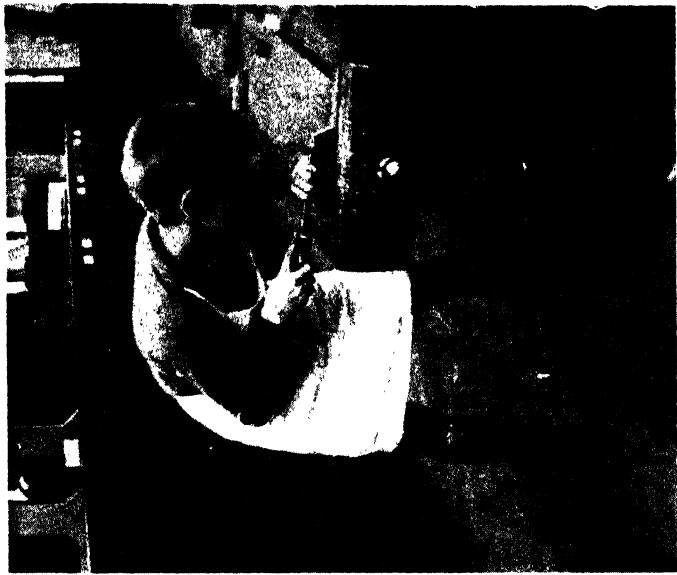

HORIZONTAL CHISELLING
Along the Grain

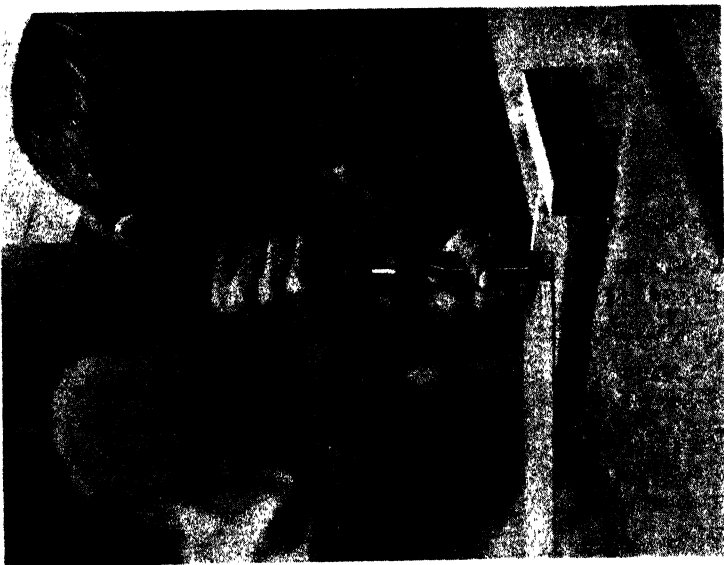

VERTICAL CHISELLING

elbow should be pressed close to the side of the body and should stay there. The left elbow and forearm must be on the bench while the fingers of the left hand grip the blade. The tool will now be



HORIZONTAL CHISELLING

Across the Grain

under complete control and the whole strength of the large body muscles can be used. Agitated arm movements lack strength and control should be discouraged.

INSTRUCTION CARD

1. Both hands must be behind the chisel edge.
2. The right elbow must be close to the side, left elbow on the bench.
3. Use the largest chisel possible.
4. Take off thin parings.

Shooting. The innocent looking shooting board produces more

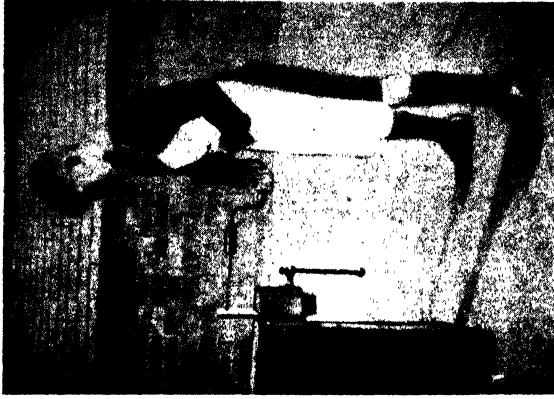

BORING



SHOOTING (END GRAIN)

cuts than all the other tools put together. The left hand should be kept well away from the sole of the plane. Long powerful strokes are required while the plane is kept flat on its bed.

Grinding and Sharpening. The boys should keep their bench tools in order.

If a holder is fitted to the grindstone all the flat-bladed tools can be ground. If left to themselves the lads will usually use only the middle of the stone, down which they will wear a groove. The quicker method of grinding is to revolve the stone towards the grinder, but as boys frequently get themselves into a mess the reverse way may be preferred. A start can be made with the broad chisels and the spare plane blades followed by the narrower tools

Good sharpening is easy if some such device as the Stanley Cutter and Chisel Grinder is used. This maintains a constant angle between the blade and the stone and banishes "rocking." A large 25° or 30° set square enables the proper angle to be set. The more experienced boys should dispense first with the set square and then with the holder.

A record of time spent on grinding and sharpening may be kept at the foot of the time sheet.

INSTRUCTION CARD

Grinding—

1. Keep the blade moving across the stone.
2. Do not grind the cutting bevel right off unless it is snapped.
3. Keep the blade in the holder until it is finished.

Sharpening—

1. Continue sharpening with the blade in the holder until there is a "wire edge" all the way along the edge on the face.
2. Keep the chisel face flat on the stone when rubbing off the wire edge.

CHAPTER V

DRAWING

DRAWING is a language by which ideas are communicated. It has its own conventions, which, if standardized, simplify their making and reading. If these standardized conventions are taught in school the boys have nothing to unlearn when they go to work. The accompanying diagram contains useful extracts from the booklet *British Standard Drawing Office Practice*, published by Crosby Lockwood.

The ability to make and read a drawing should be part of the equipment of every boy "leaver." It will be more useful to him than much of the academic upper school arithmetic.

If the handicraft centre is attached to one school only, all the drawing should be done in the classroom, except special sub-normal drawing or advanced designing. The schemes given here are in use at such a school. The ruler drawing, plane geometry, geometrical design, and solid geometry are linked up with the practical arithmetic, art, and map work. It is all practical and helps to develop visual imagination and the ability to think in symbols. Simple at the start, it gradually becomes more difficult and finishes with a course of solid geometry using materials and shapes which are more or less familiar.

When a boy comes to the craft room he brings with him enough drawings to last him some months, and continues to make them until the set is complete, after which he continues with the solid geometry scheme. He can measure accurately, use his drawing instruments and has a sound knowledge of useful plane geometry. All the centre time is spent at the bench unless he is sub-normal and needs special treatment, or is doing individual designing.

If the centre has several contributory schools, such a comprehensive scheme may be impossible, but if close contact can be made with any of them, it should be possible to get the drawings done there. The classroom should be supplied with a complete accurate set of drawings and models together with a sheet of conventions. Many class teachers know little geometry, and if their work is to be

STANDARD LINES FOR MECHANICAL DRAWING

Centre line:- ———— long chain line.

Projection and path lines:- - - - - short chain line.

Dotted lines for unseen parts:- ······

Cutting plane or section line:- - - - -

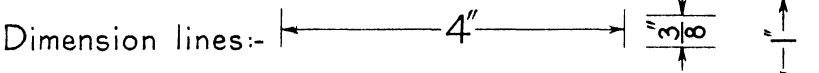

Figures to be normal to dimension lines inserted in space left for the purpose, and to read from the base and right-hand of drawing.

Vulgar fractions to have dividing line parallel to dimension line:- $\frac{3}{4}$.

Decimal fractions less than one, to be preceded by a cypher:- 0.75''.

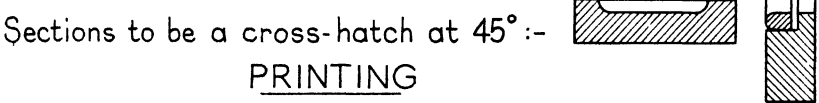

PRINTING

ABCDEFGHIJKLMNOPQRSTUVWXYZ & &
 abcdefghijklmnopqrstuvwxyz & 1234567890

PROJECTION SUMMARY

A plane is any flat surface.

Vertical & horizontal planes are used in orthographic projection.

A plan is a projection downward on to a horizontal plane.

An elevation is a projection side or endways on to a vertical plane.

The X.Y. line marks the intersection of the planes of projection.

Dimension lines to be drawn full, with arrowheads touching the lines of measurement:-

The diagram shows three dimension lines. The first is a horizontal line with arrows at both ends, labeled '4 1/2'' above it. The second is a horizontal line with arrows at both ends, labeled '1/4'' above it. The third is a horizontal line with arrows at both ends, labeled '1/4'' above it.

METHOD:- Construction - Lining-in - Dimensions etc. - Colouring.

of full value they must be helped. When this is done, the classroom drawing becomes real and a strong motive is supplied.

Should this be impracticable, the drawing must be done at the centre. It will consist of bare necessities only. Hand sketches will possibly be mainly used while some of the preliminary drawings may be duplicated and given to the lads. The formal teaching of projection need not begin at once, for if the boys are allowed to work from drawings, many things are at once made plain to them. At this stage, time spent on definitions is often wasted. Hinged boards for planes and stiff wires for projectors may be used but discarded as soon as possible. In fact, as soon as the lads understand plans and elevations they will voluntarily discard them. The *X Y* line will die a natural death. Any definitions which come out of their experience can now be formulated. By now the lads should be able to hand-sketch with some facility and should have enough bench experience to modify designs to suit themselves. Such designs may be from other drawings, pictures, or objects. In altering these ideas they will be driven to make their drawings clear, complete, and accurate. Pictorial projections, particularly that form of axometric at 15° one side and 30° on the other, are very useful for illustrating detail. This type of pictorial projection shows little top and avoids the tilted forward appearance of the usual kind.

The Three Stages. At the start every drawing should be checked and initialed at the following stages—

1. Construction—very fine lines.
2. "Lining-in"—sparkling dark lines.
3. Dimensioning, titling, and colouring.

Before starting a working drawing some practice with instruments is advisable. This will give familiarity and confidence and will teach the types of line needed and the methods of making them. If accurate drawing is required, the lads must be taught to place the chisel-edged pencil on the measurement dot and to slide the instruments up to the pencil. Double lining-in lines are often due to the neglect of this precaution, but may result from incorrect repinning after the paper has been taken off the board. Lines should usually be drawn upwards and from left to right. The use of both hands on the tee-square is to be deprecated. Most boys are quite indifferent

to the sharpness of their pencil and will cheerfully use a point like a hedge stake.

School Equipment. Many of the cheap school set squares are useless for precision work and will need truing up before they are used.

Absolute squareness is not essential in a tee-square but a warped blade or stock renders it useless. Special tee-squares should be made for left-handed boys.

Multi-ply drawing boards are best for school. They do not warp or shrink and there are no battens to project or dry out.

School compasses are rarely precision instruments and special pairs should be kept for very exact work.

Each boy should have an HB pencil for printing, figures and arrow heads, and a 2H or 3H pencil for all other lines.

The right side of the paper is hard and patternless. If the wrong side is used the first touch of a rubber will remove what face there is and leave a dirty scrubby patch. The use of the rubber should be grimly restricted. The boys should be trained to reflect before they begin. Every line should be purposeful.

Lay-out and Printing. Unless there is some reason to the contrary, the object should be drawn in its natural position. If the standard lay-out is adopted there is no need to title each part of it.

The urge to begin is so strong, that, if left to himself, a boy will start to draw almost anywhere on the paper. Training in good lay-out is needed. If well done it enhances the appearance and usefulness of the drawing, but as it is a matter of eye judgment, the equal spacing sometimes recommended is not always best. Lay-out has to take into consideration titling and subsidiary views, and needs thought.

Printing should have wide explicit letters. Tall narrow letters are hard to read. The interspaces between the letters should be narrow. Instrument printing should be encouraged but not to the exclusion of the freehand varieties.

A border line adds definition to the drawing. Unilateral underlining of titles is better than double underlining, which is unnecessary and fussy. Prettiness should be discouraged; drawings should be plain and easy to read.

Dimensions. Dimensions should be at least $\frac{1}{4}$ in. outside the

outline so that interior detail stands out. Overall dimensions of the principal members should be given so that irritating small calculations will be unnecessary when the object is being made. Dimensions should not be redundant. Arrow heads should be narrow, dark, and bold, and should touch the witness lines, which should be thin, accurately placed and not touching the outline. Horizontal dimensions should read from the bottom and vertical dimensions from the right. The dimension lines must be thin and have a middle gap in which to put the figures, which should be as large as is compatible with the appearance of the drawing as a whole. Fractions should have the solidus parallel to the line.

The most prominent features of a dimension should be the arrows and the figures, the dimension line acting only as a connecting device.

Where part of a drawing is not to the same scale as the rest, this fact should be plainly indicated.

Varieties of Line. Projection lines from drawing to drawing often hinder more than they help. If included, they should be faint and should start not less than $\frac{1}{16}$ in. from the outline.

Broken lines showing hidden details should spring directly out of the outline.

A centre line is often unnecessary, but some practice in its use as a datum line should be given.

A pale watercolour wash adds to the appearance of a drawing and gives it solidity. Boys like to colour their drawings.

Ink drawing, tracing, and blue printing are not possible unless a comprehensive drawing scheme is taken in the school. They should be the climax to the drawing and should be included where possible. Printing and developing are interesting, while the preparation of the tracings is a highly-skilled job requiring great care and patience. It is, moreover, very useful where several copies of a drawing are needed.

A folio or manilla bag for each lad is needed in which to keep his notes, drawings, and records. In a large centre each boy must have an official number to stamp on all his work.

CHAPTER VI

RECORDS

Time Sheet. The practice of keeping a time sheet focuses a boy's attention on the need for speed, and at the same time shows his teacher how the lad compares with the class average. The times given in the three stream scheme are the average of hundreds of boys. A suitable form of time sheet is given below.

NAME OF BOY		TIME SHEET		NAME OF SCHOOL
Model	Date Begun	Hours Taken	Timber	

A few seconds at the end of the lesson is sufficient to enter it up and check it.

Record Card. Detail extracted from the time sheet can usefully be transferred to a permanent record which should be printed on durable thin card. This should be completed for each piece of work and is not a long job.

NAME OF BOY		RECORD CARD				SCHOOL <i>Centre</i>	
Name of Object	Drawing		Woodwork		Tests		
	Date	Marks	Date	Marks	Date	Marks	

Wall Chart. This is easy to understand and indicates the progress of every scholar. X = one model.

SCHOOL	
John B.	XXXX
Fred, J.	XXXXXXXXXX
Arthur, B.	XXXXX
Percy, A.	XXXXXXXX

Record Book. This should be as informative as possible. The form given below is the outcome of much experience and can confidently be recommended. The book should contain a synopsis of the scheme and a centre time table.

SCHOOL		DAY			TIME
No.	Name of Pupil	Training Period	Standard	Category	Notes

The above is the heading of the left-hand pages. The right-hand pages are divided into three columns, one for each term with a test column for each. Provision can be made for recording the time each boy spends sharpening and grinding. The notes column is for details about unusual boys and a series of ticks may indicate the number of pieces of wood spoiled.

Reports. If the co-operation of the head teacher of the contributory school has been secured, he will value a report on his individual scholars. It will be a valuable link between centre and school, and may attract to the centre both head and assistant teachers. If this is done, valuable information can be gathered about the characteristics of individual boys without which there must be much fumbling by the craft teacher.

Such a report will help the head teacher to guide his boys into suitable employment.

CHAPTER VII

TESTS

Their Function. Tests of unsupervised work are scientific measuring instruments, the systematic use of which is necessary if the full benefit of the teaching is to be secured. They may test dexterity only, or general skill, or intelligence and creative ability in addition. The aim is to diagnose both teaching weaknesses and pupil weaknesses so that corrective teaching may be possible. By producing a spread of marks which may determine whether a pupil shall be relegated, retained, or promoted, emulation is stirred up and the work aerated. General progress will be shown and comparison made possible between class and class, boy and boy, and operation with operation.

By regular testing, the required standard of accuracy can be fixed and the fundamentals of the work thoroughly revised. The marking must be objective. Later in this book an account is given of some experimental tests which have proved very useful.

Bench work, drawing, theory, and spelling may be profitably examined, but of these bench work is the most important.

Bench Work. The tests can be selected from the following types—

1. Repetition of the same exercise term after term, quicker and more accurate work being required as the boys gain experience.
2. Tests becoming more difficult as the boys advance.
3. Any combination of the above.
4. Special tests for special weaknesses.
5. Tests where boys are required to design and make suitable joints or modify a given idea so as to make it fit for some special purpose. These are only suitable for advanced workers.

The exercises may be worked from pictorial or orthogonal projections corresponding to the attainments of the boys. If the boys are carefully watched while they work their tests, unsuspected gaps in the teaching will be revealed. The results should be scrutinized for common faults. If many of the boys make any one error, common correction is the remedy, but the time of the class should

CHAPTER VIII

MACHINES IN SCHOOL

If a sewing machine is a suitable school tool for a girl, what machines are entitled to a place in the craft room? As our boys will enter a world of machinery, some understanding and handling of them would appear to be desirable.

Machines are of three kinds. The first kind is driven and guided by hand. In this class come the common hand tools, which can all be included except the axe and the adze, which are possibly too dangerous for general use.

Machines where the power is mechanical and the guidance manual are useful but not essential. Some lathes, mortising and boring machines fall into this order. They can be used for extending the scope of the work, but a dash of caution should be observed if they are used. The school craft room is rapidly developing into the school studio and represents the genuine craft traditions where everything was hand made. The results obtained by using machinery of this kind are not always proportionate to the outlay, while abuse is easy.

Pure mechanical units eliminate all skill but that of the machine-setter and the designer, and have no place in a school craft room.

The schemes presented in this volume can be worked without the use of power machinery of any kind. A craftsman trained in the use of the simplest hand tools will make the better worker. He will even make the better machinist because he has been trained *in the material* and understands it.

CHAPTER IX

JOINTING

Templets (Templates). There can be little objection to the use of templets if they are made by the boy. They are invaluable when uncommon or difficult setting out has to be done. Some curves cannot be set out with the ordinary geometrical instruments, and templets may be used in the same way as a draughtsman uses his French curves.

In setting out small dovetails on coarse-grained wood they are very useful, as a bevel is often too large to be accurately used on small pieces of wood.

Where much repetition occurs, templets save time. Sketches are shown on page 78. In work such as the ends of book troughs, the use of a templet is a good method for they are so awkward to set out that few boys could be relied on to make an accurately matched pair.

When to Joint. It is safest to make all joints first and add minor constructive or decorative features afterwards. If a little extra timber is allowed on a piece to be jointed, a trial effort can be made which, if poor, can be sawn off and a fresh start made. Little stuff is wasted, while the extra practice often gives the necessary skill and confidence.

Jointing Wide Boards. The commonest ways of making broad surfaces from narrow ones are—

1. Plain rubbed joint.
2. Dowel joint.
3. Groove and loose tongue (straight, feather, and cross).
4. Tongue and groove (matched).

Whatever method is adopted, the edge should be planed square to the face even though it be warped. The pieces should be glued together so that the curvature runs right through. Jointed this way, it is easy to pull the curve straight without breaking the joint when the board is finally fixed.

The dowelled joint is probably the best for school work. It is strong and not too difficult to make.

Gluing. Only the best glue should be used. It must be hot and of the proper consistency, i.e. should run off the brush in a steady stream which should not break into drops. The joint should be quickly assembled before chilling sets in. Boys usually need help when they are gluing up, since they are often so slow that the glue sets before the job is cramped up. They also use more glue than is necessary. In cold weather the surfaces to be glued may need warming. Both surfaces must always be glued because a glued joint is really a dowelled joint with an infinite number of tiny glue dowels.

Proprietary glues are excellent, but care must be taken that the lads do not boil them.

Cleaning off the surplus glue—which should be little—can be done with hot water and shavings while it is still hot, or left until it is set and scraped off with scraper and chisel, but the best way is to allow the joint to set for half-an-hour or so when the waste glue, which will then be the consistency of stiff jelly, can be peeled off with a sharp wedge of wood or with the fingers.

CHAPTER X

FINISHING

IN times past most of the work was left in the white or finished in unsuitable media. Treacly varnish and aggressive colours spoiled much otherwise good work. The simplest finish is most suitable for boys.

Oil. Oiling with raw or boiled linseed oil is the best finish for most hard woods. Repeated applications at frequent intervals produce a rich colour, and eventually a hard, durable, heat and damp resisting surface. Any grain beauty which the wood possesses will be enhanced, but oiling is a long process requiring plenty of friction and care must be taken that the job does not get dirty.

Water Stain. No stain should be so strong that it hides the grain of the wood. If water stain is to be used, the grain of the wood should be previously "raised" by repeated applications of hot water, glasspapering between each application until the grain will rise no more. Where possible it is better to do this before the article is finally assembled. The stain should be applied with a flat stiff brush, care being exercised to keep the edge of the colour wet. When papering a stained surface, care should be taken not to penetrate the pigment. Water stain can be bought by the pound in crystal form.

Oil Stain and Scumbles. These have an oil body and with them beautiful "rubbed" effects are possible. They do not raise the grain and boys use them easily. A good brand is "Matsine" of various shades. This finish may be left unpolished as it dries with a hard egg-shell surface.

Creosote. This is widely used by furniture makers to-day for staining oak. It is cheap, easy to apply, and brings out the silver grain. It can be adjusted to any shade by diluting with lighter creosote or turpentine. Polishing can be done almost at once as it does not raise the grain and is soon absorbed by the wood. It is, moreover, a preservative.

Dyes. Household washing dyes can be used for fancy effects such as coloured strings.

Lime. A modern method of finishing is by "liming." One little-known method is as follows: The wood to be treated should first be stained rather darker than is required and a creamy paste made with powder zinc white and water. Incidentally, this is a good mixture for rubbing into the steel rules to make them easy to read. This mixture should be rubbed well into the grain, working across, and then wiped off while still wet the way of the grain. Allow to set until quite hard and lightly rub with worn flour glasspaper. Give the wood a brush coat of thinned white French polish and finally polish with Japanese wax or beeswax dissolved in turpentine. The wax in the lump may be applied to the wood, which is then vigorously scrubbed with hessian. The polish may be omitted altogether, a brisk rubbing with hessian being sufficient to produce a pleasant dull effect. This however is not very durable.

Wax. This is one of the best finishes for school work. It may be applied direct to the wood or superimposed on a thin coat of French polish. The wax should be finely shredded and dissolved in turpentine, the process being hastened by standing the container in hot water. Opinions vary as to the best consistency to use, but a good one is that of soft butter. Plenty of elbow grease is needed, and until the wax has set hard it marks easily. Heat and damp also mark the polish, which however is deep and satisfying to the eye.

A pleasing dull polish can be achieved, with or without beeswax, by vigorous burnishing with coarse hessian or canvas, silk, or a jeweller's burnisher—a tool costing only a few pence. Brisk friction with a handful of shavings, a piece of soft deal or yellow pine, produces very much the same result.

If a lump of beeswax is scrubbed with a nail brush, and the wood scrubbed hard with the charged brush, the resulting polish is quietly satisfying and durable.

French Polish. Genuine high French polishing is rare in schools, but most lads are capable of brush polishing with successive glasspaperings with worn, oiled flour glasspaper. If left unguided they invariably try to make one thick coat do the work of several thin ones. They must work from the middle of a surface to the ends and edges, or the latter will be disfigured by "tears" of polish. Such polish is best finished with wax. Articles made of light coloured woods need white or clear French polish.

If the body of a piece of work has to be finished dark, leaving strings or bands their natural colour, the latter must be given a careful coat of white polish before the whole is stained. It is then a simple matter to scrape off the polish and leave the decoration in its natural colour.

Polisher's glaze can often be used with effect on a foundation of French polish. The room where the polishing is to be done should be warm and dustless. If the polish is chilled, a "bloom" will result which is difficult to eradicate. One coat of polish should be allowed to set hard or the next will pull it up. A good brush is a medium gilder's mop with a quill stem. Polish brushes should be washed out with methylated finish and the hairs pulled to a point at the end of every lesson. Dishes must be kept clean.

Paint. The best finish for most common woods is paint. No attempt to imitate other woods or materials should be made. Painted wood should look like painted wood and nothing else. With boys the best finish for paint is French polish or enamel. Oil varnish or spirit varnish is seldom successful. Where gay effects are desired, or heat or damp likely to be encountered, the new cellulose paints can be recommended. Any paint, however, is unsuitable for moving parts. It soon wears off and leaves an unsightly scar. Varnish-stains are usually neither good stain nor good varnish. They chip and leave ugly patches.

Chemicals. Oak and mahogany may be darkened with a solution of potassium bichromate, but care is needed as it is a poison. Caustic soda solution can be used for the same purpose, but damages clothes, skin, and finger nails. It should never be used without proper precautions, while hands should be free from cuts and scratches.

CHAPTER XI

RODS

Rods or "staves" are boards, laths, or lining paper on which the jobs are drawn full size, giving all necessary details. They are, in fact,

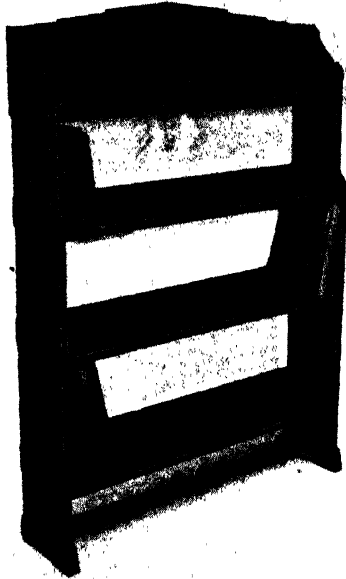

SKELETON BOOKCASE

exact sections of the work to be done. They give a clearer idea of the job than a scale drawing and are much more accurate because they dispense with all calculations. Elevations are not always essential except in curved or complicated work, and need not be mentioned here.

Yellow pine boards, 8 in. or 10 in. wide, $\frac{3}{4}$ in. or $\frac{1}{2}$ in. thick, are ideal for the purpose. They should be planed both sides and rubbed with a lump of white chalk to show up the pencil lines. The boards

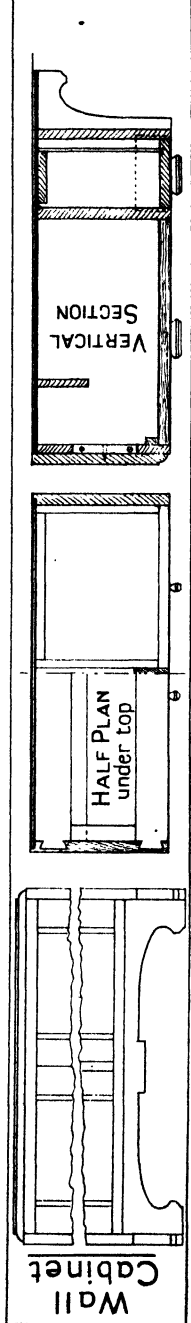
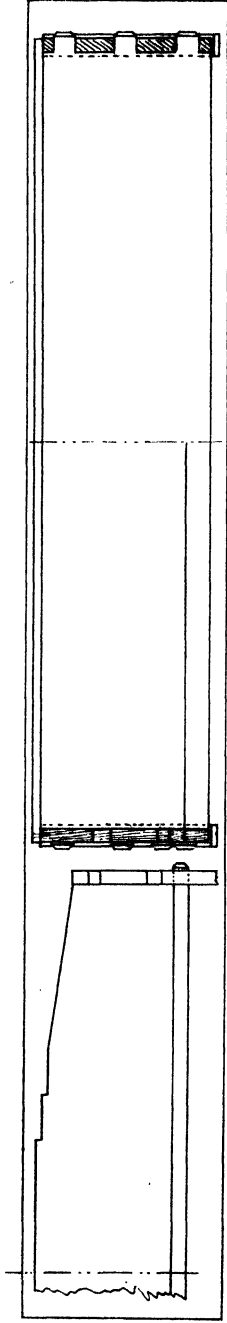
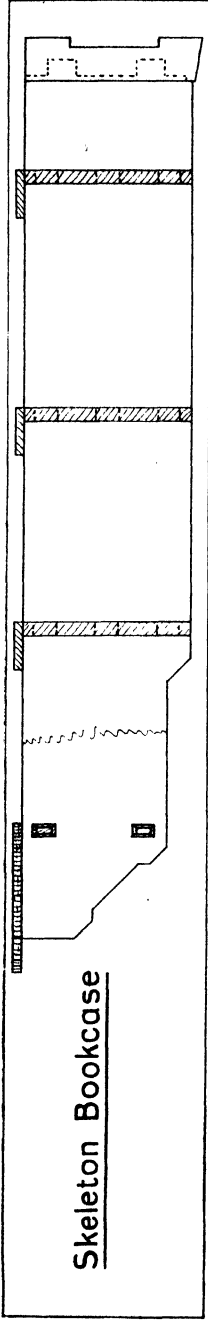

SPECIMEN SETTING OUT "RODS"

can be used repeatedly if replaned and chalked again. Plywood is useful, but is not so easy to plane off.

If the article is a popular one its rod can be semi-permanent. The use of rods in the handicraft room expedites the work considerably. An example is shown in the accompanying drawing.

CHAPTER XII

“WHAT TO MAKE” SUGGESTIONS

MANY boys have little idea of what to make when they are faced with the problem of striking out on their own, and need some help. Sheets of suggestions similar to the undermentioned are useful in filling this gap until some strong lead from the boy is obtained.

1. Bring a safety razor blade and make a string box. Make sure that the string and the blade can easily be renewed.

2. A toilet roll is . . . wide. Design a fitting.

3. Make a box of two compartments to hold two packs of playing cards.

4. A cigarette is . . . in. long and . . . in. thick. Design a lined box to hold a hundred.

5. Design and make a plain inkstand to hold two school inkpots.

6. Design a carved, veneered, or inlaid finger-plate.

7. Roller towelling is . . . in. wide. Design a towel roller to hang behind a kitchen door.

8. Bring the shoe brushes from home and make a box for them which can also be used to rest the foot on while polishing the boots.

9. Design and make a stocking darning.

The above are, of course, only elementary suggestions which every man can amplify and extend for himself. If such suggestions are printed on thin card it is an easy matter to distribute them, and they can be amended when necessary.

CHAPTER XIII

AN EXPERIMENT IN TESTING

Aim. This investigation was undertaken with a view to clearing up if possible some points which had been matters of opinion and for which no figures were available. It was also intended to show that a woodwork examination is as informative as any other school examination.

The main features are indicated below—

1. An enquiry was instituted into the relationship between general school ability and mechanical efficiency with common woodworking tools. Many people still believe that though a boy does poor academic work he will do well with his fingers. A statistical survey was expected to throw some light on this question. Boys who do mediocre or poor general school work are often sent to swell the ranks of the artisan, while the best brains are usually advised to take a black-coated job. This starves the skilled trades of their quota of brains and initiative.

2. It was proposed to compare the efficiency curves of typical groups of boys to find where the peaks, if any, occurred, and to discover how long typical boys took to acquire reasonable tool handling efficiency. It was hoped that the results would show at what stage of training in tool manipulation the change over of control from the higher to the lower brain centres could be expected.

3. A comparison was made between the test results from schools in different districts to see if conditions of heredity, family tradition, environment, and feeding were reflected there. This was to form a basis for organizing schemes of work for the schools under scrutiny.

4. In academic subjects there is evidence that speed is usually associated with accuracy. It was desired to test this relationship for tool manipulation. The tests therefore had to include time as a marking factor.

5. The investigation was expected to show at what age or training period no appreciable advance in accuracy or speed could be expected.

6. An effort was made to discover which tool operations gave most trouble so that special remedial teaching could be given.

7. During the whole of one year, the test was given to all the new boys to discover what native tool handling skill they had.

An unusual system of marking was introduced. Finished test pieces were handed to colleagues who were asked to assess them. Differences of estimation up to 100 per cent occurred. Any system which results in such wide divergencies is unsuitable for a scientific investigation. The method here set down is logical, stable, and accurate. Its value does not lie in its application to routine bench work but to systematic testing.

Another equally valuable feature is that in the centre where this system was introduced, it helped to produce a standard of accuracy and finish never before attained.

The schools contributing boys to this test were—

- (a) A school for deaf children.
- (b) A school for feeble minded.
- (c) An elementary school devoted to Jewish children.
- (d) Two elementary schools in better-class artisan districts.
- (e) Three schools in poor slummy districts.
- (f) Forms 3A and 3B of a secondary school.

The results of the mentally deficient boys were eagerly awaited,

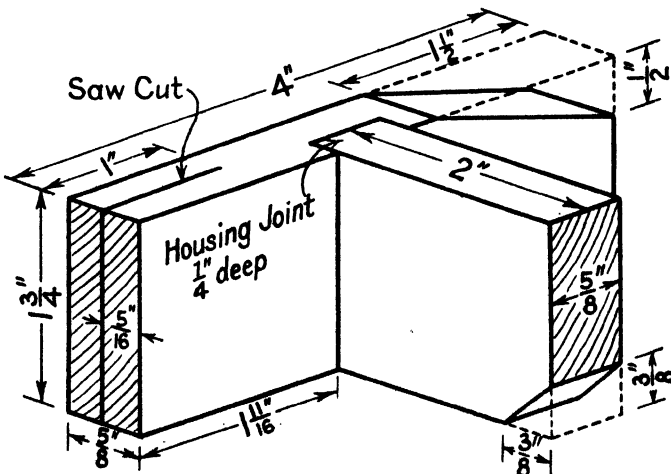

Fig. 1

for it had been noticed that the majority of these children did their work as well after two months as they did after two years' tuition.

The two secondary school forms were taken as representative of the boys who pass out of the elementary school at about the age of 11.

INSTRUCTIONS

1. Plane face side and face edge.
2. Gauge and plane the exact width and thickness.
3. Take your work to the teacher.
4. Using pencil, rule, gauge, knife, and square set out the test exactly as you have been shown.
5. Saw and chisel the notch.
6. Saw off the ends.
7. Set out and saw the long saw-cut.
8. Saw off remaining waste wood and chisel the sloping surfaces.
9. Stamp your number on both pieces and put up your hand.

- Note.*
1. Both speed and accuracy are necessary.
 2. Do *not* clean up your test when it is finished.

The Test. Exactly the same test was given at the end of every term under precisely similar conditions.

The tools of which each boy possessed one were the plane, tenon or dovetail saw, rule, knife, gauge, square, 1 in. chisel, and $\frac{1}{2}$ in. chisel.

The tests therefore had to fit them. This excluded many interesting tool manipulations, but it is hoped without any serious effect upon the efficiency of the tests. The fundamental exercises, measuring, planing, long sawing, cross sawing, gauging, squaring, chiselling, horizontally, across and along, vertical chiselling, use of knife and pencil which are the basis of all woodwork, were all included.

Accuracy determines the quality of craftwork in wood, therefore size is the most important fact in a tool manipulation test.

The efficiency of a craftsman must take into account his speed of working so that speed had to enter as a factor and not as a casual consideration.

The timber used was yellow pine (Weymouth pine), 7 in. by $2\frac{1}{4}$ in. by $\frac{3}{4}$ in., free from knots, short grain, or sapwood.

The tools were sharp. Pictorial projections of the test (Fig. 1)

were distributed, and the boys allowed a few minutes to examine them. The teacher gave a rigidly standardized demonstration, working the test from the rough wood. The attention of the boys was drawn to the precision and speed of working, and to the résumé of the demonstration printed below the drawing.

No further instruction or help was given. As each boy finished his planing he brought it to be assessed, then went back to the bench

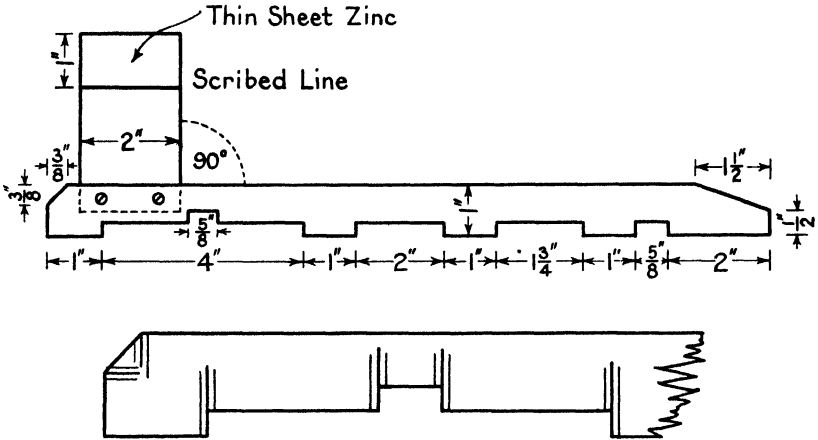

Enlarged View of One End showing Scribed Lines

Fig. 2

and finished the job. As each test was completed, the teacher timed it in minutes and the boy numbered it. This routine was never varied.

Marking. A strip of hard wood was prepared as a gauge and in it were cut notches to fit every measurement (Fig. 2). This gauge was accurate to about a hundredth of an inch. Each notch had a fine scribed line at both ends and on each side of this line was cut another, exactly $\frac{1}{16}$ in. away. One line thus indicated the correct dimension plus $\frac{1}{16}$ in., the middle line was accurate, while the other showed a measurement $\frac{1}{16}$ in. too small (see Fig. 2). The slopes were then cut, and a piece of thin sheet zinc on which was a scribed line 1 in. from the end was cut, fitted, and screwed into position, square with the gauge.

Errors of less than $\frac{1}{16}$ in. were ignored. For all others one mark

was deducted irrespective of their size. A mark was also deducted for every careless or unnecessary tooling. If, for example, a saw cut were obliterated by chiselling or filing, five marks for that saw cut were deducted together with one more, called an "extra" tooling mistake. If an operation were omitted all marks for that item were deducted. The marking was impersonal and mechanical.

Marking sheets of the illustrated pattern were duplicated.

SCHOOL.....

Date.....

No.	Plg	Mg	Sawing		Chiselling			Extras	Time	Total errors	$\frac{100 - E}{T}$	Marks
			L	X	X	L	V					
1	2	3	4	5	6	7	8	9	10	11	12	13

The explanation of the columns is as follows—

1. The boy's allotted number.
2. Planing mistakes.
3. Measuring mistakes.
4. The long saw cut in the end.
5. End and notch sawing.
6. Chiselling the notch.
7. The long chiselled slope.
8. The small vertically chiselled slope.
9. All errors unassessed elsewhere plus added errors due to bad tool marks and unnecessary operations.
10. The time in minutes.
11. Columns 1 to 9 totalled.
12. Formula figures ready for ready reckoner.
13. The final result.

The columns were completed for every test piece and marks totalled; thus the boy with the smallest score had done the most accurate work.

The following formula was adopted—

$$(100 - E) \times \frac{K}{T} = \text{marks scored.}$$

E = marks lost by student.

T = time taken by student.

K = 35.

It was arrived at as follows—

When the first 400 results were to hand, the records were searched for the four boys (1 per cent) who had made the most mistakes. These results were 102, 100, 98, 97, giving an average of 99.2 mistakes. It was not expected that results worse than these could possibly come to hand. To make calculation easier the figure 99.2 was taken as 100. Each boy, therefore, could make 100 mistakes, for every one of which a mark would be deducted.

The formula so far runs: $(100 - E)$.

This figure was then divided by the boy's time which gave $\left(\frac{100 - E}{T}\right)$. This fraction would have conveyed no meaning to the boys, as a standard time was required with which to compare it. The records were again searched for the four boys who had done the test in the shortest time. These were 39, 38, 37, and 31 minutes, giving an average of 36 minutes, and 35 minutes was taken as a constant. This completed the formula: $\left(\frac{100 - E}{T}\right) K$, that is:

$$\left(\frac{100 \text{ marks minus number of mistakes}}{\text{Boy's time}}\right) \text{ multiplied by standard time 35 min.}$$

If a boy made no mistakes and spent 35 minutes on his work his marks would be—

$$\frac{100 - 0}{35} \times 35 = 100 \text{ per cent or 100 marks.}$$

The Ready Reckoner. With a slide rule all scores for no mistakes up to 100 and all time from 35 minutes to 115 minutes were calculated and embodied in a ready reckoner, which was well worth the

trouble. An extract from the top left-hand corner is given below. Suppose the boy made six mistakes and took 38 minutes—

$$\frac{100 - 6}{38} = \frac{94}{38} \quad \text{Read 94 top line.}$$

Then down to 38 which gives 87 marks.

		90										9		
		100	9	8	7	6	5	4	3	2	1	0	9	
3	5	100	99	98	97	96	95	94	93	92	91	90	89	
	6	97	96	95	94	93	92	91	90	89	88	88	87	
	7	95	94	93	92	91	90	89	88	87	86	85	84	
	8	92	91	90	89	88	88	87	86	85	84	83	82	
	9	90	89	88	87	86	85	84	83	83	82	81	80	
		40	88	87	86	85	84	83	82	81	81	80	79	78

The marks were thus read direct. This took but a second or two. The work of calculating the results was accurate and rapid. This is an absolutely stable system of marking which indicates, both relatively and actually, any progress made by a scholar. A scale of true values is given, based upon child performance and not on the subjective, fluctuating standard of an examiner.

At the beginning the time required for recording, calculating, and marking was about seven minutes per test, but as it became more mechanical this was reduced to an average of two minutes.

The Findings: Speed and Accuracy Relationship. In handicraft, as in many other fields of activity, power is usually associated with speed. There is a good deal of nonsense talked about the slow patient worker and his remarkable results. Handel wrote "The Messiah" in three weeks.

As a means of exploring this question for tool manipulation, the whole of the results of this investigation were analyzed. The boys were arranged in groups according to the number of mistakes. The times taken by all boys who made ten mistakes or fewer, i.e. the 0-10 group, were averaged. The same procedure was adopted with the boys who made eleven mistakes up to and including twenty—the 11-20 group—and so on up to a maximum of seventy mistakes. As very few boys made more than seventy mistakes their times were included in the 61-70 group.

As will be seen by referring to the curve the times taken are almost directly proportional to the number of mistakes made. The quickest workers made the fewest mistakes. If the hump in the

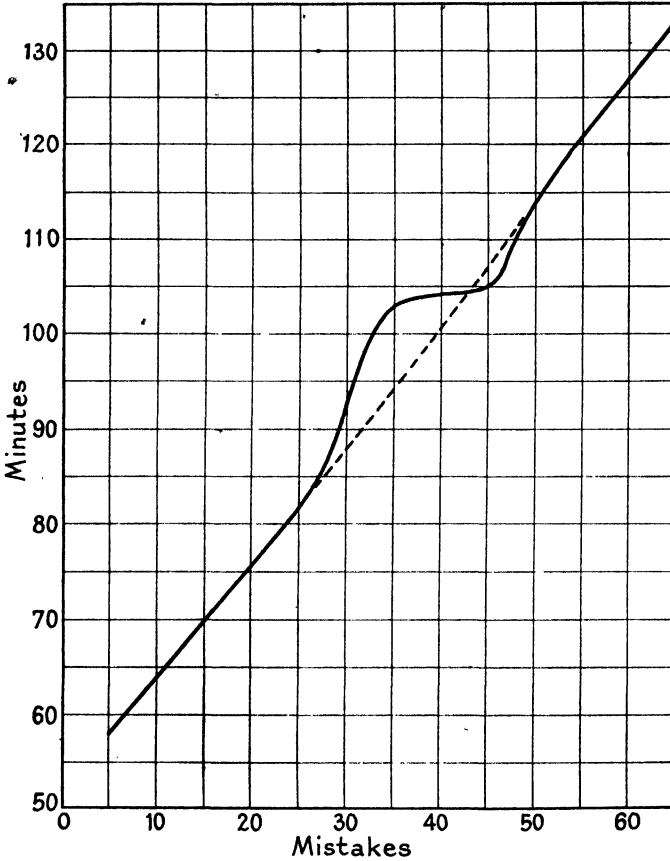

Fig. 3

middle of the curve is ignored the result is practically a straight line.

An attempt was made to get an alternative curve by arranging the results in groups according to the time taken and plotting them against the averaged mistakes. The following time groups were plotted 30–35 minutes, 36–40 minutes, up to and including 146–150 minutes. This gave a very irregular curve, roughly conforming to Fig. 3, but as some of the groups consisted of very few boys the

figures obtained and the resultant curve were not considered reliable enough to be included here.

General School Ability in Comparison with Tool-handling Ability.

There appears to be an increasing tendency to give the backward boy more handwork and yet more handwork, and to regard this as the solution of the problem of his education.

The cases where the boy does poor academic work but good craftwork are very rare. Occasionally, however, craft enables a boy to gain his lost self-respect. As a boy comes up the school he may get the reputation of being a duffer, and it is remarkable how quickly he accepts his status, and fatalistically conforms to what is expected of him. The tradition handed on from class to class holds him down by destroying his confidence and self-respect. In the craft room he is in a new and different environment. He starts level with his fellows, and sometimes succeeds in regaining self-esteem. This usually results in better general classwork. Such cases, however, are not very numerous.

With a view to examining this question more fully and accurately, one school only was taken. The class teachers of this school were asked to assess the general school ability of every boy. The craft tests of these marked boys were analysed and tabulated. Those boys assessed by their class teacher as V.G., V.G.I., and EX. had their average test marks shown on one curve, whilst those marked Poor, Weak, Dull, Slow, etc., had their craft tests results plotted on another. These two curves are shown in Fig. 4. This method, the only one possible under the circumstances, could, of course, be only a rough guide. The rings on both curves indicate small groups of boys whose numbers were too small to ensure the reliability of the averages obtained. These breaks do not interfere with the picture presented by the curves.

It will be noted that 50 per cent is not reached by the poorer boys at the end of seven terms, whilst the better children get there at the end of the third term.

The upper curve shows roughly twice the efficiency of the lower curve.

These findings show how closely the results in the craft room approximate to those of the classroom, and suggest that craftwork is not an alternative form of education, but is part of a general

training. Handwork is possibly the best means of approach to a dull or backward boy, but it is not a substitute for his general education. That tool handling ability is a function of general

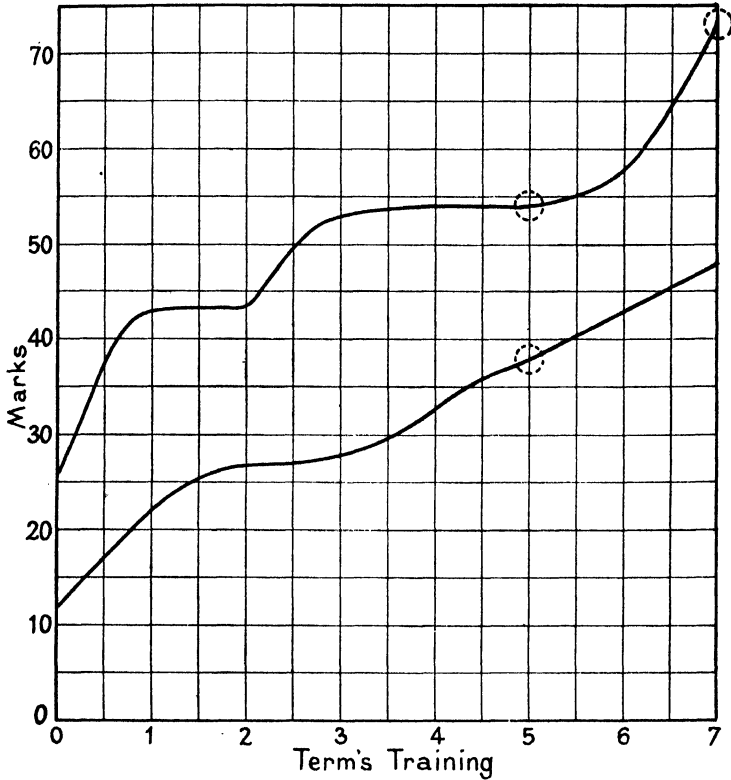

Fig. 4

intelligence is, one thinks, shown quite clearly in these curves for craftwork.

The upper curve is of the typical growth type. It is irregular and proceeds by a series of leaps rather than by a smooth progression.

The lower curve shows very slow progress. It will be seen that the original tool efficiency of a dull boy, tested on his first visit to the handicraft centre, is about half that of the quicker boy, and that this deficiency is maintained throughout his school handicraft life.

Speaking generally, the intelligent boy makes the best craftsman.

Secondary School Boys in Comparison with Elementary School Boys. This is a comparison between average secondary school boys and average elementary school boys. The elementary schools are those mentioned in subsections *c*, *d*, and *e* in the Introduction. Boys from forms 3A and 3B, age 11-13 years, of a secondary school were tested over a period of two years, and their test results compared with those from the elementary schools. All the boys were about the same age, and the same period of two years was taken.

As secondary school pupils are mainly a selected lot they were expected to be more intelligent and more industrious than the non-selected elementary school boys. They were also assumed to be healthier and usually better cared for. It has been calculated that at least 10 per cent of the population is mentally subnormal. The larger part of this percentage passes through elementary schools, but only a very small proportion gets into secondary schools. The results were expected to show this superiority.

On examining Fig. 5 we find large differences. During the first two terms of training the advance of the secondary school boys compared with that of the elementary school boys is in the ratio of 1.7/1, although their original untrained tool skill is apparently slightly less. This superiority is most marked and is well maintained.

The dip in the curve—the plateau—is assumed to be the place where the control of the manipulative functions is transferred from the higher to the lower brain centres. This causes retardation and apparent retrogression. The tool handling has not become completely automatic, and yet it is easier than it was and does not absorb all the available attention. There is consequently a slackening of concentration, with the result that the quality of the work suffers, and the output is not maintained. This period, roughly about two terms in duration, persists until automatism is more complete. This stage appears to be reached about the end of the fourth term for the whole of the boys under scrutiny. In the handicraft centre this period of transfer is one of apparent retardation and retrogression. Lazy short cuts are taken instead of the traditional routes, and slovenly, untidy tooling is very evident. This produces slow, inaccurate, and often very irritating work. It is, however, the result

of a very necessary process, for which allowance should always be made. It is here suggested that all consideration of original work be postponed until this period of flux is over. This will give freedom to wrestle with problems of construction, difficulties of handling new tools, and plans of attack. Advancing complexity in design calls for an ever-increasing parallel development of manipulative skill.

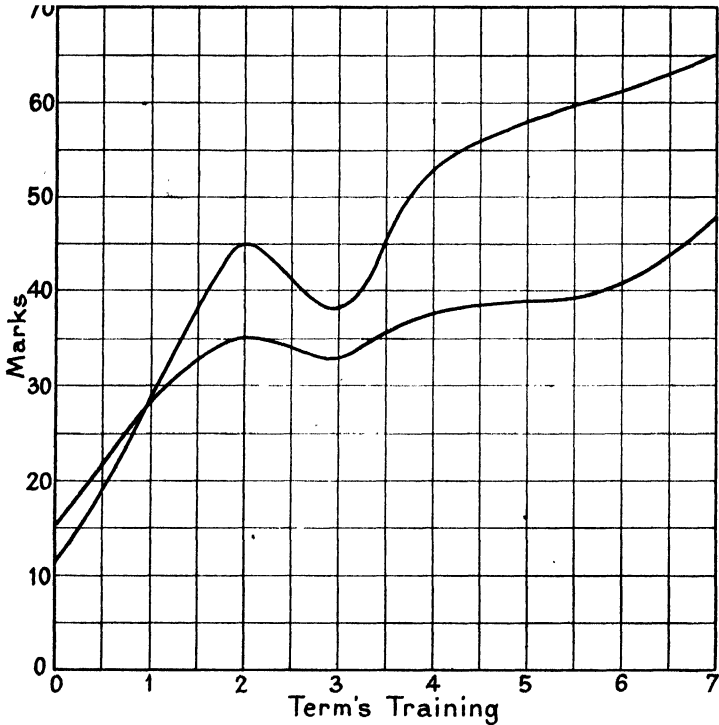

Fig. 5

Design depends upon material and tools, and only by accident can good design be produced by one having little knowledge of the limitations of the material to be worked, and the possibilities of the tools employed in working it.

The dip in the curve is deeper in the case of the secondary school boys than is the dip in the other curve, but at its lowest point it is higher than any previous point in the elementary school curve. After the fourth term the ratios of increase in efficiency are about the same in both cases. The achievement of the secondary boys

is much the higher throughout, and the length of time taken to acquire reasonable efficiency (50 per cent) is only four terms as compared with the seven terms of the elementary boys.

Best Elementary in Comparison with Average Secondary School Boys. This picture is a combination of the upper curves of Figs. 4 and 5; the best of the elementary school boys who have graduated

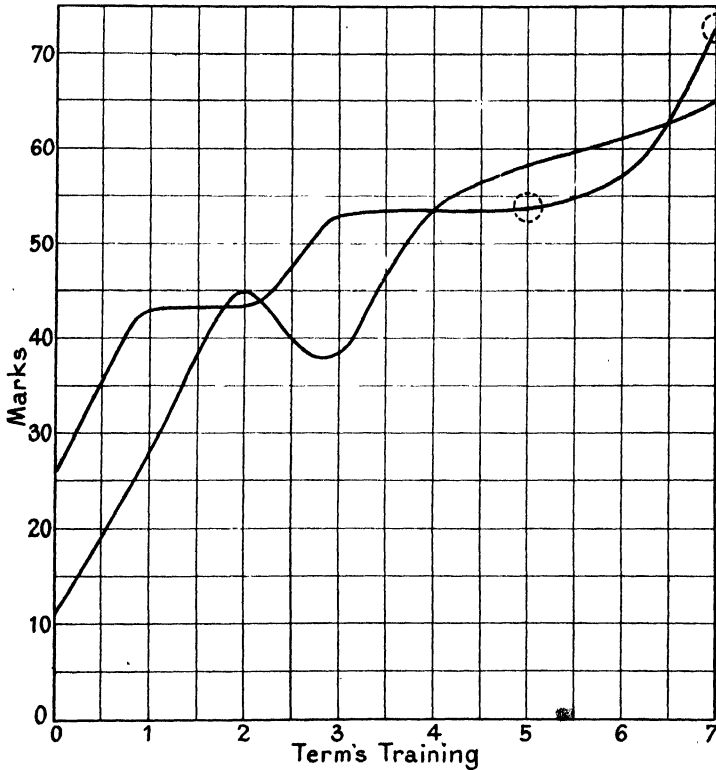

Fig. 5a

to a secondary school compared with the best remaining boys of a good elementary school.

It will be seen that the best elementary school boys apparently possess twice the initial tool handling ability of the average secondary school boys. The rates of increase for the first term are equal, but the retardation period occurs almost immediately for the elementary school and persists for one term. This is followed by a rise almost similar to the first, and then by a retardation period of almost three

terms. This is followed by a final sharp rise at about the same angle as the two previous ones.

This last slope is not reliable, as the group producing the point on the line was too small to ensure the reliability of the figures obtained. The secondary school curve shows a steep rise for two terms, then a pronounced flagging for a further term followed by a

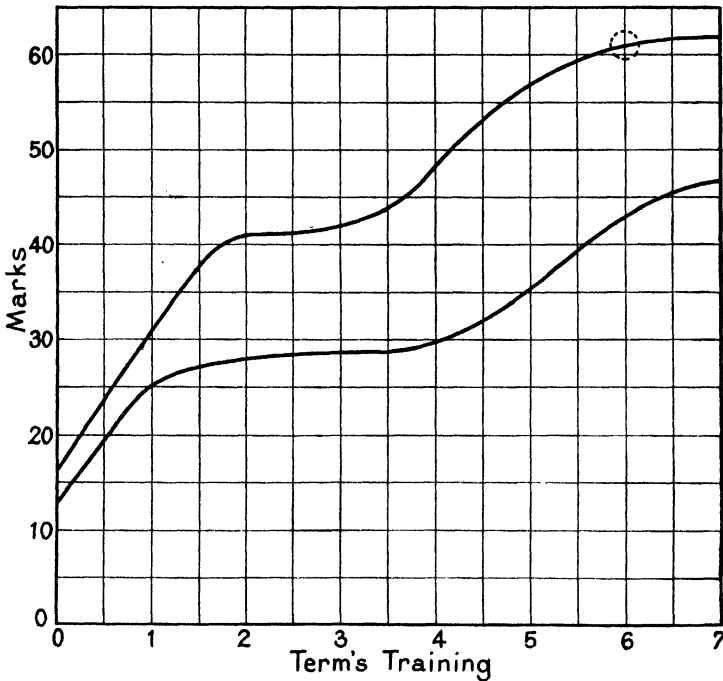

Fig. 6

sharp rise parallel to the first. At the beginning of the fifth term a steady gradual increase in efficiency sets in, which persists until the end of the seventh term. It would appear that the best elementary school boys achieve reasonable efficiency a term earlier than the average secondary school boy, but that their subsequent development is less rapid.

Good Districts in Comparison with Slums. The upper curve belongs to a school in a good district. The lads from this school were on the whole better fed, housed, and cared for than any other elementary school boys attending the centre. They filled the

department for three half-days a week. The lower curve gives the average results from three schools in poor slummy districts. These schools occupied the centre for one half-day each, so that the two groups were roughly of equal size, about four hundred boys in each group.

The salient feature of this diagram is that even at the end of

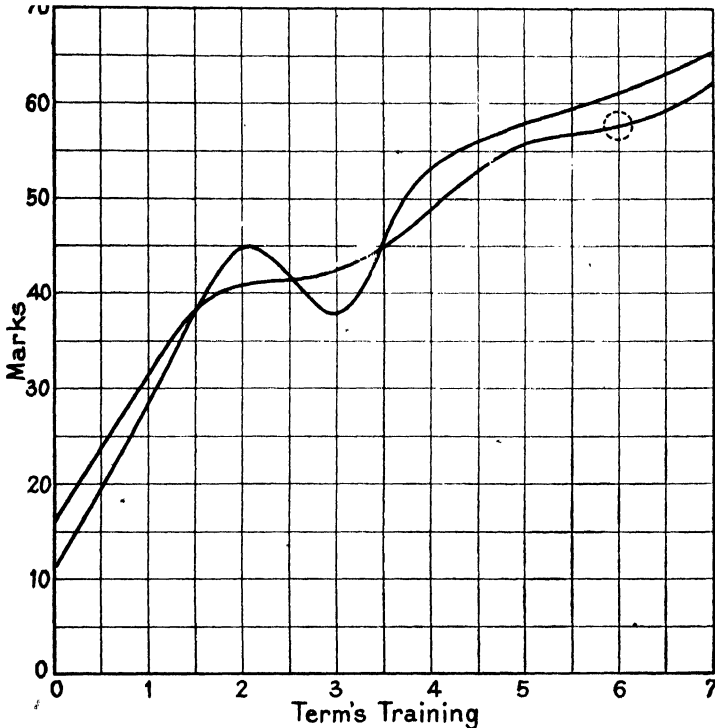

Fig. 6a

seven terms, the poorer schools had not arrived at average efficiency 50 per cent, while the better school required only slightly more than four terms to get there. The lower curve shows a much slower growth, and a long period of retardation—about three terms. The upper curve is of quicker slope, with a retardation of one term only.

The initial efficiency of both groups is about the same.

If the upper curve is compared with the curve for the average secondary school boy, Fig. 6A, a very close resemblance will be found. The performance of the secondary school scholar is definitely

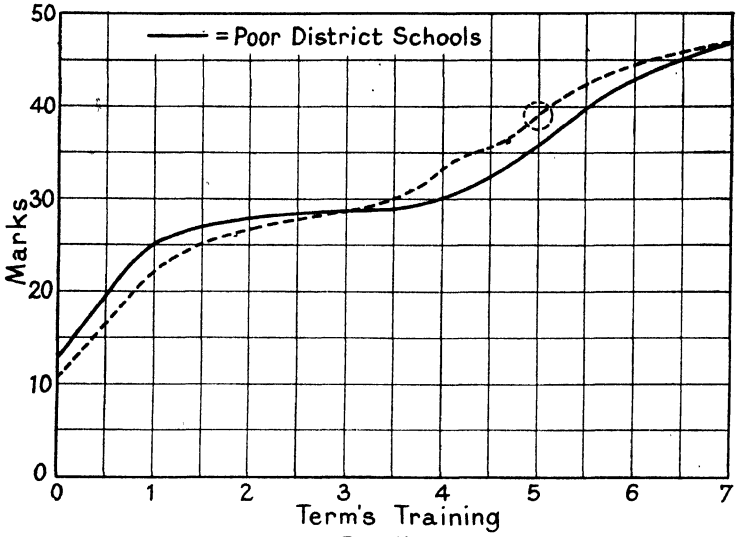

Fig. 6b

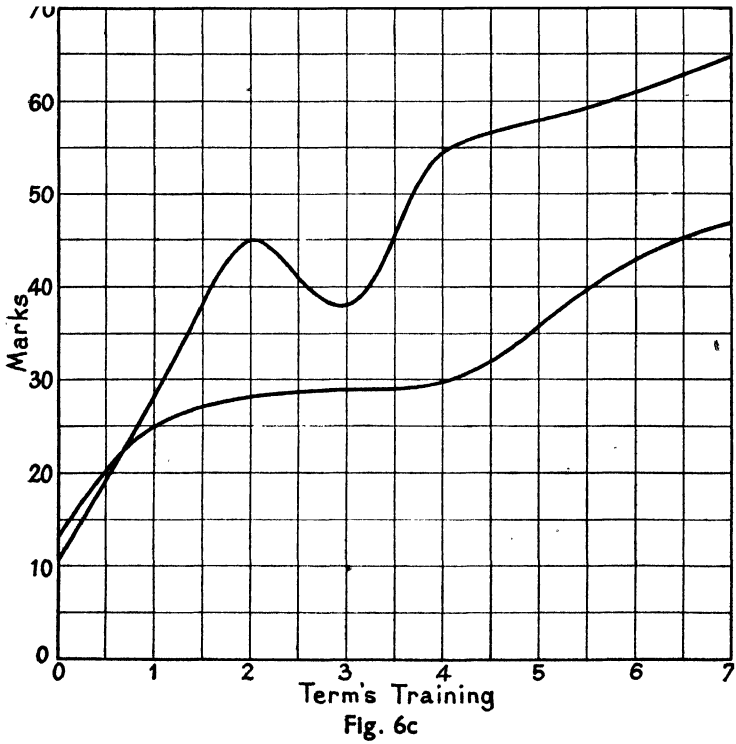

Fig. 6c

slightly better than that of the good district elementary school boy. The differences are not large, but quite definite.

Comparing the average performance of the slum schools with that of the poor boys from the better school we get Fig. 6B. The average standard in the poor districts appears to be about equal to that of the weakest boys in the good class district. These findings indicate the necessity for different schemes for boys in different districts attending the same handicraft centre. They also suggest that it is futile to expect the same quality work or speed of working from all schools.

Fig. 6C gives a contrast between slum boys and secondary school boys. Comment, one imagines, is unnecessary.

A SCHOOL FOR THE DEAF

The writer was transferred from the centre where the experiment was performed before sufficient data were obtained from the school

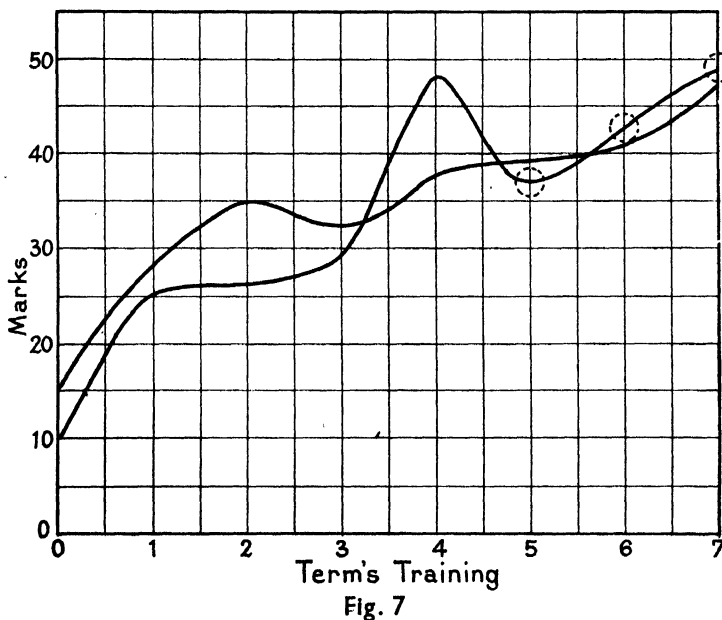

for the deaf to make reasonable comparisons. The class was one of twenty boys, and so the groups were too small to permit any reliable generalizations being made.

The results were expected to be superior to those from normal elementary schools, as the routine bench work was very good indeed.

The boys were about a year older on the average than any elementary contributory classes. As little difference as possible was made between the teaching of the boys from this school and the other schools attending the centre.

The curve is given for what it is worth. The groups for terms 5, 6, and 7 were very small, being about three or four boys only. The results from the other term groups are more reliable as the groups were much larger. The period of retardation occurs at the end of the first term, and continues until the beginning of the third term. There are indications that if the experiment could have been continued the results might have been superior to those from normal departments.

A SPECIAL SCHOOL

This curve is also given for what it is worth. The total number of special school boys examined was smaller than the number of the deaf boys in the last section. The average age of these boys was about equal to that of the deaf boys.

During the teaching of handicraft to mentally deficient boys for more than ten years it had been observed that the boys started the course, the lessons, and the models with much enthusiasm. At first a fair amount of skill was achieved. Then, as the novelty and consequent interest lost its appeal, the work flagged, and the standard was not maintained. Boys of this type are easily daunted, and take every opportunity of standing on one leg and gazing listlessly and apathetically around them. At the first appearance of difficulty they collapse, and let events take their course. Such boys are easily interested by novelty and change, but the interest does not last. Lassitude and lethargy creep upon them, and work becomes too much of an effort to pursue.

The initial enthusiasm is quite clearly shown in the diagram, as is also the subsequent collapse to the standard which experience suggests is normal. The last two points on the curve are quite unreliable because of the smallness of the groups.

The findings are the more interesting because the special school boys spent about five times as much time at handwork as the elementary school boys, while in the centre, very little theory and

no drawing was taken, so that all their time was spent at the bench.

A suitable course of work for special schools would perhaps consist of small pieces of work which could be executed in one or two lessons. Such a course might with advantage be one which for a long time would contain no smaller dimensions than $\frac{1}{8}$ in. Simple sawing, chiselling, and nailing exercises constructed from slater's

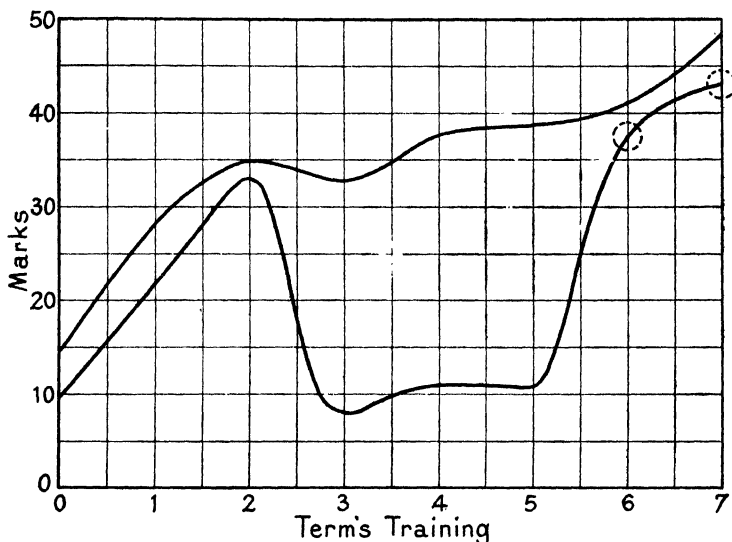

Fig. 8

lath might prove suitable for an introductory scheme. Communal and repetitive work are suitable for more advanced work. The normal lesson of two hours duration might with advantage be shortened.

NORMS

The norms for the whole of the results are—

Training	Marks
None	13
1 term	28
2 terms	38
3 terms	36
4 terms	44
5 terms	50
6 terms	55
7 terms	58

ANALYSIS OF MISTAKES

TOOL OPERATION	AVERAGE MISTAKES	
	Per Model	Per Operation
Extras	7·2	—
Long Saw Cut	4·0	4·0
Horizontal Chiselling (Long chisel cut)	1·9	1·9
Vertical Chiselling	1·5	1·5
Cross Chiselling (Floor of notch)	1·1	1·1
Measuring	1·1	—
Cross Sawing	4·1	0·7
Planing	1·9	0·5

In the second column the mistakes are graded according to single operations. As several of these were repeated in the test the totals are given in the first column.

It is common to find work spoiled by bad "finish." Such errors consist of bad tool marks, scribed lines where none should occur, bad gauging, and the like. These mistakes appear in the table as "Extras" and easily top the list, being almost twice as numerous as any other, and constituting one-third of the total marks lost.

The long saw cut seems to have been six times as difficult as a cross saw cut, and accounts for about one-sixth of the total errors.

The long sloping chisel cut has caused a larger loss of marks than either of the other two chiselling operations.

As many marking lines were cut off it was impossible to discover accurately how many of the mistakes were due to bad measuring. The figure given above is accurate for those setting-out mistakes which could be assessed.

Probably owing to the fact that soft wood was used, the planing error mark was the lowest. If the test pieces had been made from hard wood the results might have been different.

CONCLUSIONS

Briefly summarized, the deductions from the experiment are as follows—

1. Reasonable efficiency in tool handling is arrived at by average secondary school boy in four terms; good elementary school boy in three terms; average elementary school boy in five terms; poor

elementary school boy possibly during the eighth term, but not before.

2. General social conditions are strongly reflected in the work, and should be budgeted for when drafting schemes of work.

3. Efficiency in tool handling follows very closely efficiency in other school subjects. Unintelligent boys do not produce good craft-work, and their initial ratio of deficiency remains fairly constant.

4. There is no indication of an unusual capacity for handwork in the sons of labouring and artisan parents.

5. Speed and accuracy are closely allied.

6. The experiment was not successful in determining at what stage no further advance in tool technique could be expected. The curves all finish with an upward trend.

7. For these tool manipulations the change over of control from the conscious to the habitual probably occurs after about two terms, and the disturbances caused thereby are most marked in the work of the better quality boy but are sooner overcome.

8. Growth of tool control is not steady, but conforms to other types of growth in being irregular.

9. Deaf boys can be expected to do work of at least equal merit to that of normal boys.

10. Change and novelty are essential in any course of work designed for mentally deficient. A lower standard of accuracy may be expected.

11. The simple tool operations in increasing order of difficulty are: planing, cross sawing, measuring and cross chiselling, vertical chiselling, long horizontally chiselled surfaces, and last and most difficult—sawing with the grain.

PRACTICAL TESTS AND VOCATIONAL GUIDANCE

Any scheme of vocational guidance or vocational selection which relies solely on the evidence supplied by academic attainments tests, intelligence tests, tests of temperament, and school reports is incomplete because it takes no account of dexterity, skill and practical intelligence. Since practical work in schools is now universal, scientific vocational testing on a more exhaustive plan has become possible.

In past experiments the practical ability of a boy has been largely ignored or only recognized to the extent of giving him simple dexterity tests such as bead threading, block placing, and string knotting. Simple dexterities, however, tend to be specific and unrelated to each other, or to anything else, while practical ability is a more general co-ordinated thing. Any practical tests included in such an experiment should, therefore, be complex and should require reflective thinking. They should explore the ability to plan and execute a routine and should bring into play many psycho-physical relationships.

The tools used should be fundamental and familiar to the testee, preferably those he has a reasonable chance of owning and using in the future.

The tests should be so designed that speed can be included or excluded at will, for we require the highest speed compatible with extreme precision.

In general, muscular fatigue should not enter.

The marking should be objective and mechanical, and the results should approximate to the normal distribution curve.

7%	should be very poor.
24%	„ „ poor.
38%	„ „ average.
24%	„ „ good.
7%	„ „ very good.

The materials should be cheap, and the test conditions capable of easy and complete reproduction.

The following results are included by the courtesy of the Director of Education for Leeds.

In connection with a vocational guidance scheme, 154 boys of school-leaving age from five elementary schools were given—

1. Dr. Burt's Northumberland Arithmetic Tests.
2. The Northumberland English Tests.
3. The Northumberland General Intelligence Tests.
4. The foregoing woodwork test modified as follows—

- (a) No demonstration was given.
- (b) The printed guidance was omitted.

The boys had to read the drawing, plan their own routine, and

execute it with tools of their own choice—file, glasspaper, and shooting board excepted. It was thus a test of practical intelligence as well as a test of tool manipulating ability.

The highest woodwork mark scored was 114.

The lowest mark was 12, and the average was 50. The results followed the normal distribution curve very closely. The boys were divided into five categories according to their marks.

- A. 114 marks down to 84 marks.
- B. 83 down to 64 marks.
- C. 63 down to 44 marks.
- D. 43 to 24 marks.
- E. 23 to 4 marks.

The boys in each category had their arithmetic marks averaged. The general intelligence and English marks were also averaged. The results are shown.

Woodwork Category	General Intelligence Mark	English Mark	Arithmetic Mark
<i>A</i>	308	362	281
<i>B</i>	279	319	208
<i>C</i>	275	307	214
<i>D</i>	259	287	191
<i>E</i>	247	260	177

The correlation between the woodwork, English, and general intelligence group marks is perfect, i.e. 1, while the woodwork and arithmetic group marks give the high correlation of .9.

These results suggest that a practical test of this nature might usefully form part of a scholarship examination. It would give a boy, with special intelligence for dealing with things, a chance he might not otherwise get. Such a chance is already given to a boy with special arithmetical ability.

Of the five schools examined, one contributed only eight boys, and its results are omitted from the following table. Schools *P*, *Q*, and *R* are University Demonstration Schools in good-class artisan districts.

School S is a poor district school.

School	General Intelligence Average	Average Woodwork Mark
<i>P</i>	293	53
<i>Q</i>	279	52
<i>R</i>	281	50
<i>S</i>	251	41

Here, again, general social conditions are strongly reflected both in the general and practical intelligence test results.

CHAPTER XIV

THE THREE STREAM SCHEME

THE scheme is not designed to cover any specified period of time. It is expressed in terms of craftsmanship. Working one half-day per week, an exceptional boy will make all the "A" exercises in a year or less. The average boy should make about the same number of "B" models, while the poor boy will make seven or eight "C" exercises over the same period. Thus the "C" boy may never pass out of the scheme unless he is put on to communal work.

A Joint. The course begins with a joint because it emphasizes the need for accuracy at the outset. In times past it was customary to start a course with small articles which, even if inaccurately made, were suitable for use and quite efficient. Plant labels and string

THE THREE STREAM SCHEME

	A	B	C
1	Half-lap joint	Half-lap joint	Half-lap joint
2c b a	Swing towel rail	Tie rack Swing towel rail	Housing joint Tie rack Swing towel rail
3c b a	Book ends	Crumb tray Book ends	Rebate and butt Crumb tray Book ends
4c b a	Hat and coat rack	Blotter Hat and coat rack	Mortise and tenon Blotter Hat and coat rack
5c b a	Tea tray, plate drainer, or cutlery box	Teapot stand Tea tray, plate drainer, or cutlery box	Dovetails Teapot stand Tea tray, plate drainer, or cutlery box
6c b a	Book troughs	Ink stand Book troughs	Double stopped housing Ink stand Book troughs
7c b a	Swing mirror frames	Swimming certificate frame Swing mirror frames	Dowel joints Swimming certificate frame Swing mirror frames

winders are the type of article referred to. A joint, however, if badly made, is a source of weakness, and normally renders useless the article in which it is introduced. Skill is necessary for accurate work, and insistence on accuracy is the best training for skill.

The Table. Since in a normal class the boys are mainly of average ability with a top of super-normals and a bottom of sub-normals, the scheme is three-fold and consists of three vertical lines of progress. The lines of equal difficulty are horizontal and are common to all three lines of progress. The primary models are the "A" models, around which the scheme is built.

In general, every boy makes seven "A" models, plus six "B" models if he is a "B" boy, while the "C" boy makes six more. The "C" exercises prepare for the "B," which in their turn clear the ground for the primary exercises.

A scheme of this type allows transfer from one category to another at any stage of the course, and enables promotion and relegation to be made without dislocation of the steady stream of progress. The position of a boy in his category is thus the index of his ability. The teacher's work book has a column for recording and altering this classification if necessary.

The scheme is, of course, non-rigid. Modifications will occasionally be found necessary for boys of unusual abilities or disabilities. It is, however, a framework and a plan of attack which permanently underlies all individual modifications until the stage is reached when the pupil is able to make anything in which he is interested.

Every boy starts with No. 1, during the making of which it is generally possible to select the "C" boys who then proceed along their own section. When the tie rack and swing towel rail are complete, the "A" boys will have emerged.

Designs. These rely for their appeal mainly upon proportion, outline, colour, suitability for purpose and the principles of good craftsmanship, rather than upon the addition of superficial or meretricious decoration.

Decoration and Finish. In the main these partake of the nature of the material itself, and emphasize the characteristic quality of the wood. Each exercise must be given the most suitable finish for the material and the function of the finished article.

Instruction Methods. If all the instructional methods are standardized the danger of boys falling between two stools will be avoided. Instruction cards in various processes can be usefully employed. Individual boys should be encouraged to work from written as well as oral instructions.

Planed Wood. Planed wood can be extensively used. Many boys of small or undeveloped physique are quite incapable of planing large surfaces of hard wood with any degree of accuracy or finish, and it is thought that no good purpose is served by keeping such lads planing for long sterile periods. These boys are normally capable of performing the less strenuous but equally valuable manipulations with smaller tools. There are so many interesting and educational processes involved in woodcraft that it is open to question whether such plane slogging has any value except as a training in patience and perseverance. It slows up the work tremendously, and as there is little or no novelty or variety in it, interest sickens and dies.

Speed and interest are essential. Speed is necessary for interest, and interest is vital. The usefulness of an object must be self-evident, and if designs embodying these qualities and consisting of interesting processes are presented, little difficulty is experienced in getting both quality and quantity.

In this scheme a definite attempt is made to depart from the boredom and lack of beauty associated with the more usual soap-box, tooth-brush rack type of work.

Timber. The quality and kind of timber is used as a reward and a stimulant. Any boy who tries really hard or who makes a good job can be allowed to use harder and better timber. The "C" boys usually use the softer and more amenable timbers.

Sales. In the advanced stages wood is sold to the lads, as the cost of large quantities of big articles may be more than the non-sales requisition will bear.

Mouldings. The use of bought mouldings and turnings is not encouraged, and in no case are they used to hide faults of design or workmanship. Simple inlaying, veneering, gouge cuts, are more effective and more adequately represent the true craft ideals.

Nails. The use of nails is discouraged.

Advanced Designs. A folio of dimensioned designs is kept for

the use and inspiration of advanced workers, who are encouraged to use them, and to adapt and modify the designs to suit their needs.

Library. A library is kept which the boys use for research and information.

Illustrations. Pictures of notable and historic pieces of craftwork are displayed round the room. Numerous demonstration models,

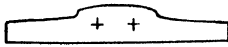

TRAY HANDLE

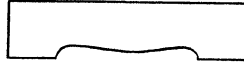

CLEARANCE FOR FEET

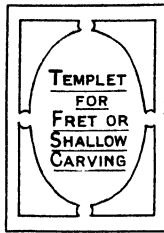

FOR THIS CARVING

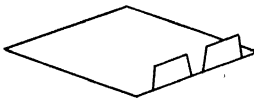

DOVETAIL TEMPLET

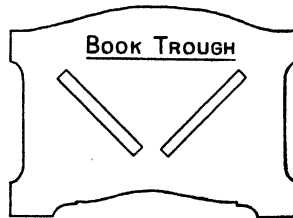

TEMPLETS

usually teachers' work, are on view. These are handled, measured, and examined by the boys, and copied or used as the germ of an idea for other pieces of work.

The course is set out in full, and hangs on the wall while the corresponding exercises are suitably housed in a case to which the boys have access at all times.

Taste. No piece of work is on view unless it is a good specimen. Poorly designed or badly executed pieces of work debase the taste of the scholars. Cultivation of taste and appreciation of craftsmanship are fundamental aims of handicraft teaching.

Templets. Where the construction involves much repetition, the use of templets is allowed. They are also used where curves difficult to set out are to be worked.

Reports. A report book for each contributory school is prepared and the class work and test results of all boys reported on to their school at the end of every term—or as often as is thought advisable. If the head teacher can be co-opted, he can give much help by his sympathetic backing. This system helps both school and centre, and serves to bind the rather loosely-knit fabric together. It also helps to minimize the effect of a boy's divided loyalties.

Time Sheet. Each lad keeps a record of the time spent on each model, which is checked at the end of every lesson so that it is easy to keep track of individual performances.

Record Card. Full details of all centre activities are entered by the lad on a record card. This gives at a glance all the information necessary to study him individually and to compare him with his fellows.

Spelling List. Each boy has a spelling list.

Hints. Cards of hints and tips are displayed round the room, and instruction cards in technical processes are regularly used.

Half-lap Joint—

YELLOW PINE

11 in. × 1½ in. × 1 in.

Average time 6½ hours

This wood is soft, easily worked, and cuts clean. It is straight grained and fairly free from knots.

Timber supplied to class in slabs 11 in. long. The boys rip these down with the wood held upright in the vice.

Planing, see page 23. Gauge drill will be necessary.

Cut a line around the wood ¼ in. from each end, using striking knife and square. Measure 5 in. from each of these lines and cut other lines round. Shade the wastewood at the ends and in the middle. On the face side cut another line across 2 in. from the end line, and from this line cut another rather less than 1 in. away. Carry these lines across the edges but not across the other side. Repeat this setting out at the other end on the opposite side. Set the gauge to half the thickness of the wood, and from the face side

gauge the depth of the notches. With the knife deepen one end line and nick in on the waste side. Using this nick, saw the end square, with the bench hook held in the vice. Repeat at the opposite end, deepen the notch lines, nick in and saw down to the gauge lines, holding the wood in the vice. Horizontally chisel the notches with the $\frac{1}{2}$ in. chisel. The floors of the notches should be quite flat. Deepen

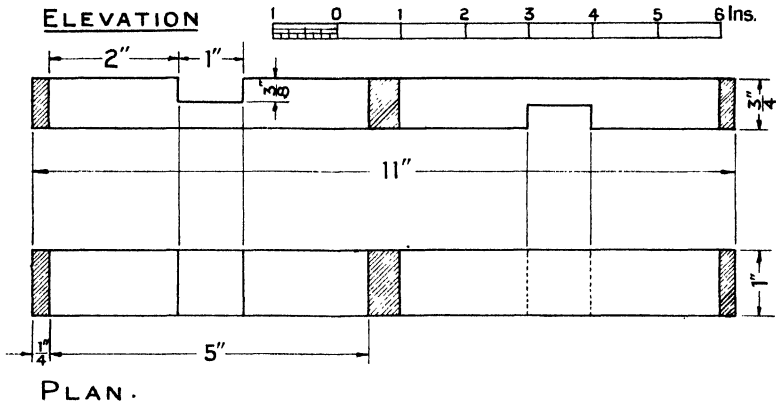

HALF LAP JOINT

the two remaining length lines, nick in and saw off. With pencil and steel rule mark corner chamfers on the face side, and vertically chisel with the 1 in. chisel. Place the two members face upwards tandem fashion against the bench stop, and with the iron plane clean off. Turn the two pieces over and repeat. Place one piece on the bench, notch upwards, and clean the edges of the other until, when fitted into the notch the reverse way, it is a tight knock-in fit. Repeat this for the other piece. With fine glasspaper laid on the bench, paper all sides and edges. Drive the joint together, using a piece of wastewood and a hammer. Label it so that it may be identified.

Housing Exercise—

CANARY OR SATIN WALNUT

10 in. \times $2\frac{1}{2}$ in. \times $\frac{3}{4}$ in.

This is a preparatory exercise to the tie rack to be made by "C" boys.

Plane up and shoot one end. From it measure $2\frac{1}{4}$ in. and cut

line round with knife and square. Measure and cut round another line a shade less than $\frac{1}{2}$ in. from the first. Gauge depth of notch from face side and nick in. Saw and horizontally chisel the joint, making the floor very slightly concave. If this is spoiled there is enough wood left to make another.

With pencil at the finished end, set out the two long slopes; chisel them horizontally with 1 in. chisel.

Shoot the other end, and with the gauge and knife set out the bare-faced tenon. Make the long kerf with dovetail saw; nick in and saw the shoulder.

Mark the lengths from respective ends and in the waste, saw off $\frac{1}{16}$ in. from the lines. Shoot.

Draw pencil diagonals and bore hole with centre bit or Irwin twist bit. Set out and chisel corner chamfers.

Clean off with iron plane and glasspaper. The joint must be a tight "knock-in" fit.

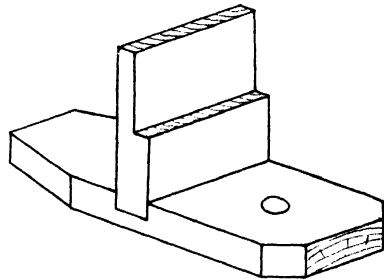
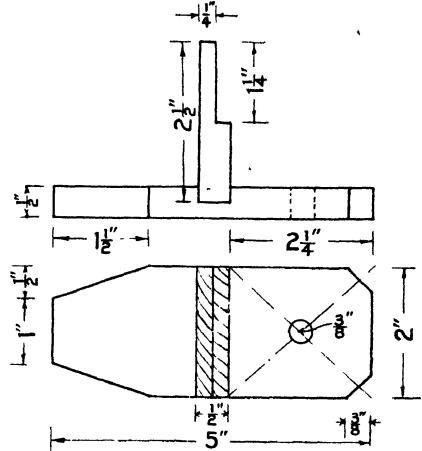

HOUSING EXERCISE

Tie Rack—

CANARY WOOD, SATIN WALNUT OR MAHOGANY

Dowelling 9 in. \times $\frac{3}{8}$ in.

$16\frac{1}{2}$ in. \times $2\frac{1}{2}$ in. \times $\frac{1}{2}$ in. or $\frac{3}{4}$ in.

Average time $7\frac{1}{2}$ hours

Plane up as usual unless planed timber is used, when it will only be necessary to plane one edge and gauge and plane to the width. Shoot one end, and 1 in. from it cut a line around the wood. From this line measure a shade ($\frac{1}{32}$ in.) under $\frac{1}{2}$ in. Cut another line round. From face side gauge depth of notch $\frac{1}{4}$ in. Deepen the lines on the

face side and nick in on the wastewood; fasten the wood in the vice, and saw the notch. Chisel from both edges with $\frac{1}{4}$ in. chisel, making floor very slightly concave. From the end already shot, measure the full length of the back and cut a line around; saw off $\frac{1}{16}$ in. from the line and shoot to length. Mark and work the notch at this end exactly as first one. Draw pencil diagonals at the ends of the back, punch with centre punch, drill holes with hand drill, and countersink them. Draw pencil diagonals at the back of the notches for screw holes. Punch, drill, and countersink. Set out the corner chamfers

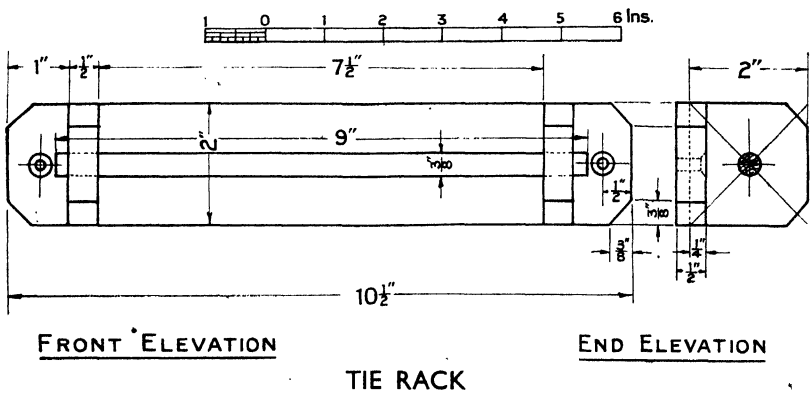

with pencil and rule, or pencil and templet on the face side and chisel vertically. Shoot both ends of the remaining piece, and from each end measure 2 in. Draw pencil diagonals in each square for centres of holes. Bore practice holes in wastewood. Bore $\frac{3}{8}$ in. holes in shelves with Irwin twist bit. Set out corners and chisel vertically. Deepen lines on face side, nick in, and saw to length. Clean off face side of back with iron plane and glasspaper (No. $1\frac{1}{2}$ or fine 2). Place shelves one behind the other against bench stop and clean both sides until they fit tightly into the notches. Glasspaper by rubbing the shelves on the glasspaper not *vice versa*. Glue the notches and the ends of the shelves, force together in the vice and screw, using $\frac{3}{4}$ in. by 5's or 6's. Saw off dowel rod, file the ends flat, holding it in the fingers. File a small chamfer at each end, glasspaper the whole and fit. If it is slack, pin into position with a $1\frac{1}{4}$ in. fine panel-pin. Cut off the head before it is driven quite home and hammer flush. Plane the back and the edges with iron plane and glasspaper, using cork rubber.

Swing Towel Rail—

OAK, MAHOGANY, OR CANARY WOOD

1 piece $8\frac{1}{2}$ in. \times $3\frac{1}{8}$ in. \times 1 in.

„ 6 in. \times $3\frac{1}{8}$ in. \times $\frac{3}{4}$ in.

„ $18\frac{1}{2}$ in. \times $2\frac{1}{4}$ in. \times 1 in.

Average time 9 hours

If planed timber is used the bare thicknesses shown in the drawing are sufficient. If oak or mahogany is used, no stain or polish is needed. The wood can be left in the white and waxed.

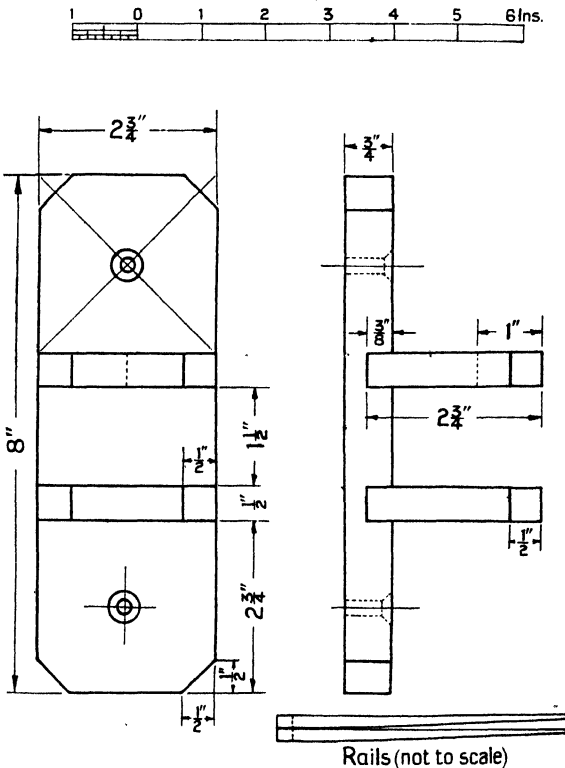

SWING TOWEL RAIL

Back. Plane up and shoot one end, and from it measure, saw, and shoot to length. From one end consecutively measure the following distances: $2\frac{3}{4}$ in., $\frac{7}{16}$ in., $1\frac{1}{2}$ in., and $\frac{7}{16}$ in., and cut lines around the wood. Gauge depths of notches from face side. Deepen lines on face, nick in and saw to depth. Chisel out with $\frac{1}{4}$ in. chisel,

making floor slightly concave. Draw pencil diagonals in squares; punch, drill, and countersink holes. On the back, mark, punch, drill and countersink screw holes. Set out corners and chisel vertically.

Shelves. Plane up in one piece. Shoot both ends, set out corners, and vertically chisel. Draw a pencil line along the middle of face side and, 1 in. from one end, prick a hole through with a bradawl, using the blade across the grain. Measure $2\frac{3}{4}$ in. from each end and cut lines round. Nick in on wastewood and saw to length.

Clean face of back with iron plane and glasspaper. Treat shelves similarly and make them a tight knock-in fit. Apply glue to ends of shelves and inside of notches. Force together in vice and screw, using 1 in. by 7, or 1 in. by 8 screws.

Rails. Plane up with two face edges. From each edge gauge $\frac{1}{8}$ in., and rip down between the two lines. Plane to widths and shoot one end of each piece. Saw and shoot both pieces to length, 18 in. From one end of one piece measure 1 in., and square a pencil line round. Prick a hole through the middle of the line, working from both sides. This is for the panel pin. Two inches from this line square similar line round and set out the lines for the slope on the rail edge. Plane it, and using this piece as a template set out and plane the other. Mark the corner chamfers on the thin ends and chisel. Clean up as usual with iron plane and glasspaper; make the rails a sliding fit.

The glue should now be set. Plane up the back and the edges of the back and shelves, being careful to keep them flat and square. Glasspaper these and the front ends of the shelves.

With a chisel clean off any glue from the face, and push a $2\frac{1}{2}$ in. panel pin through the hole in the top shelf and through the single rail. Push the other rail into position, making sure that the ends and sides are flush with the upper rail. Drive in the panel-pin.

This is a sturdy useful wall fitting which, when not in use, occupies little space. It can be modified to hold as many rails as desired.

Rebate and Butt Joint—

ANY HOMOGENEOUS SOFT WOOD

7 in. \times $2\frac{1}{2}$ in. \times $\frac{3}{4}$ in.

Plane up and shoot one end. From this end and $\frac{1}{2}$ in. away, cut

a line on the opposite side to the face side and across both edges. From the face side gauge the line for the rebate. Deepen and nick in the shoulder line. Saw down and remove the waste, working from both edges and chiselling horizontally.

At the other end set out the curve with the wing compasses, and work it with coping saw, chisel, and glasspaper.

From the ends measure the lengths of the respective pieces. Saw off and shoot to length. Set out the long slope with rule and pencil, and the curve with wing compasses. Chisel and glasspaper both.

Fit the joint, plane up, and glasspaper the inside surfaces. Three-sixteenths from the end of the shorter piece drive in two $1\frac{1}{4}$ in. panel-pins. Glue the joint, drive home the pins, and cramp up square. When the glue is set, clean off outside with plane and glasspaper.

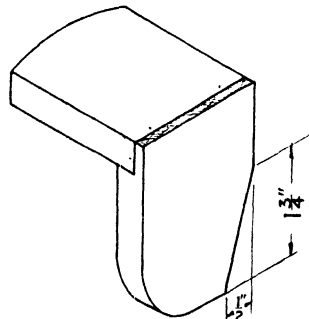
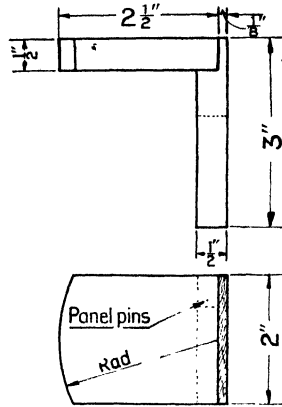

REBATE AND BUTT JOINT

Crumb Tray—

OAK, MAHOGANY, WALNUT, OR CANARY WOOD

- 1 piece $10\frac{1}{2}$ in. \times $1\frac{5}{8}$ in. \times $\frac{1}{2}$ in.
- 2 pieces 7 in. \times $1\frac{5}{8}$ in. \times $\frac{1}{2}$ in.
- ply 10 in. \times $7\frac{1}{2}$ in. \times 5 mm.

Average time 8 hours

Oak is a very suitable wood for this job, as the plane surfaces show off the silver grain to advantage. It is, however, awkward to joint.

Plane up back and sides to width and thickness. Shoot one end of long piece, and $\frac{3}{8}$ in. from it cut a line across the opposite side to the face side and across the two edges. Set the gauge to $\frac{1}{8}$ in., and from the face side gauge a line for the rebate. Nick in on waste side of line, and saw to gauge line. Horizontally chisel the wood out of the rebate with a $\frac{1}{2}$ in. chisel. From this end, mark, saw, and

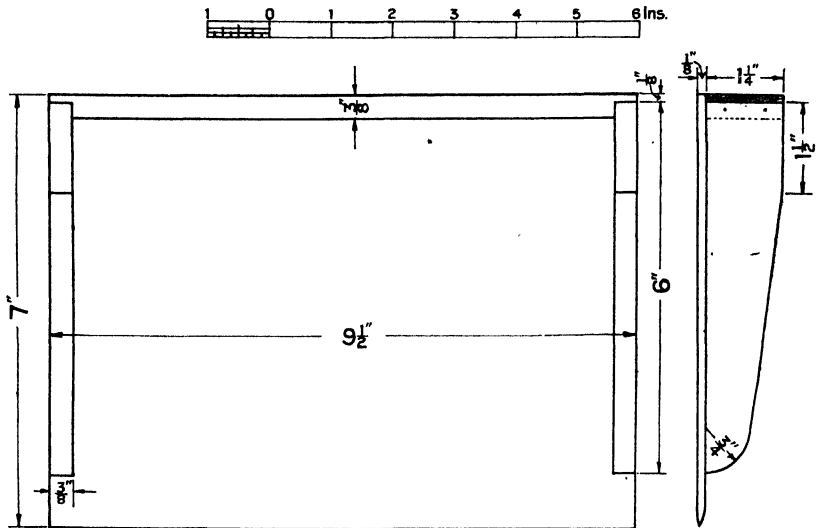

CRUMB TRAY

shoot to length. Set out and make joint as at other end. Shoot one end of both side pieces, and set out shape with rule and wing compasses. Plane the slope, saw off the waste, and chisel the curves. Glasspaper. Clean the inside of back and both wings, and $\frac{1}{8}$ in. from the square end of side pieces pencil line around. On this line from the unplanned outside drive in $\frac{3}{4}$ in. panel-pins until their points project slightly on the line at the other side. Glue the joint and drive home the panel-pins with fine nail punch. Cramp up in vice, making sure that the sides are parallel, square, and out of wind.

Plane long edge of plywood and shoot one end at right angles to it. Measure length from this end by placing framework on it. Saw and shoot. Draw width line and plane. Placing wood flat on bench, file a knife edge on one long edge. Glasspaper both sides;

$\frac{3}{16}$ in. from back edge draw line on both faces, and drive in five $\frac{3}{4}$ in. panel pins at equal distances until the points project.

Plane bottom edge of frame flush and pin the ply down, leaving the pin heads projecting $\frac{1}{8}$ in. Similarly pin the sides down. Pass the finger round the frame, inside and out, to discover if pins are projecting or likely to project, and with punch drive heads slightly below the level of the plywood face.

Put the tray edgeway up in the vice, plane the back and sides flush, and glasspaper. Plane and glasspaper top edges of frame. Clean off any spare glue from the inside corners with the chisel and scrape if necessary.

Book Ends—

- 1 piece 11 in. \times $4\frac{1}{2}$ in. \times $\frac{3}{4}$ in.
- „ $4\frac{1}{2}$ in. \times $3\frac{1}{2}$ in. \times 1 in. or $1\frac{1}{4}$ in.
- Average time $7\frac{1}{4}$ hours

These will be made in pairs, and any hardwood can be used according to the design and decoration adopted. Thicker wood will make heavier and sturdier articles.

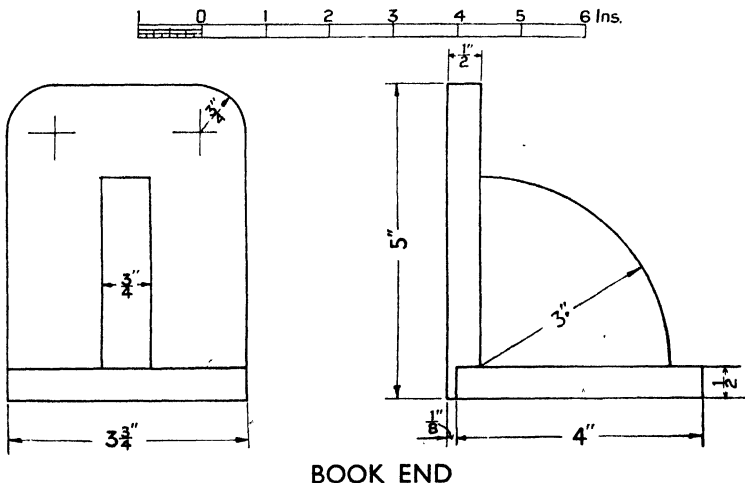

BOOK END

Plane up and shoot the ends. Set out and work the rebate at one end as in the crumb tray. From each end measure lengths of respective pieces. Saw and shoot to length. Glasspaper the ends. Set out the outline and work with coping saw, chisel, and glasspaper.

Plane up and set out the strut. Work the desired decoration and shape this member, using coping saw, chisel, and glasspaper again.

Glue the joint and pin with $1\frac{1}{4}$ in. panel-pins, punching them below the surface. Fix the strut with a touch of glue and panel-pins. Punch them below, and put the book end into the vice until the

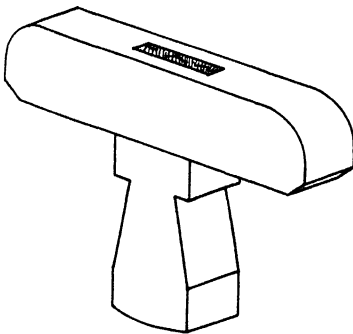
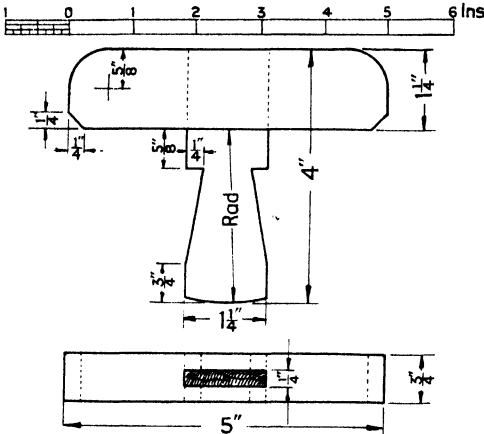

MORTISE AND TENON JOINT

lines with knife. Touching the wastewood side of the line with the saw, make the two long saw cuts. Deepen shoulder lines; nick in and saw them. If this tenon is spoiled another can be made at the same end.

Shoot the other end, and $1\frac{7}{8}$ in. from it, set out mortise with gauge, square and pencil. Mortise through from both sides. Set out length of this piece, and $1\frac{1}{2}$ in. from each end of it square pencil

glue has set. Clean off and glasspaper.

Cut from a sheet of zinc or brass an oblong $3\frac{3}{4}$ in. \times 2 in., and polish with flour emery. Hammer-mark with ball pane hammer. File the edges true and smooth, and fix to underside of model, using round-headed brass tacks which will not scratch furniture. The oblong should project $1\frac{1}{4}$ in.

Mortise and Tenon Joint—

YELLOW PINE, RED DEAL, CANARY, OR SATIN WALNUT
 $1\frac{1}{2}$ in. \times $1\frac{1}{8}$ in. \times 1 in.

Plane up and shoot one end. Set mortise gauge to width of $\frac{1}{4}$ in. mortise chisel, and from the smooth end set out the tenon, cutting the shoulder

lines round. Draw pencil diagonals and set out arcs with wing compasses. Set out corner chamfers with rule and pencil.

From the tenon end of the wood, mark length of short member. Set out slopes with pencil, and curve with compasses. Saw apart.

Shoot end of long piece and work curves with 1 in. chisel and glasspaper. Vertically chisel the corner chamfers.

Vertically chisel the end curve of the other piece and glasspaper it. Deepen shoulder lines of sloping surfaces and nick in. Saw down and horizontally chisel.

Clean off all edges; fit and glue the tenon, using a notched cramping board to take any projecting tenon.

When glue has set, clean off sides and remove any surplus glue. Glasspaper.

Blotter—

YELLOW PINE OR OTHER LIGHT WEIGHT WOOD
PLYWOOD-BIRCH OR TO MATCH

1 piece $6\frac{1}{2}$ in. \times 3 in. \times 1 in.

„ 7 in. \times $1\frac{1}{4}$ in. \times 1 in.

„ $6\frac{1}{2}$ in. \times 3 in. \times 5 mm.

Average time $9\frac{1}{4}$ hours

Plane up and shoot to length the base piece. Draw a pencil line midway around the wood and another at right angles to it midway along the length. On either side of the cross-line measure a bare $\frac{3}{8}$ in. and square pencil lines around. Set the mortise gauge to the width of a $\frac{1}{4}$ in. mortise chisel. Place the points equally on either side of the middle line, push the gauge stock tight against the face edge and screw up. Gauge the mortise on both sides, working from the face edge. Mortise with light $\frac{1}{4}$ in. mortise chisel and mallet. Draw curves on edges and work in vice with mallet and 1 in. chisel or flat carving gouge with bevel downward. File and glasspaper.

Plane up stem, and set out tenon from face side, using previous setting of gauge. Saw tenon tongue, leaving line intact, but cutting off all wastewood. Nick in shoulder lines and saw shoulders with a little undercut, holding wood in vice. If tenon has been badly made, saw off and remake. From shoulder measure $\frac{1}{2}$ in. twice and square pencil lines around. Set out and work the wedge mortise, using same gauge and chisel. Set out length and draw a pencil centre line

down face side. Set wing compasses to $\frac{3}{8}$ in., and draw semicircle on face side only, the ends of it being joined to the top mortise line with rule and pencil. Saw off all but $\frac{1}{8}$ in. of waste and plane slopes. Work round end with 1 in. chisel and glasspaper. Glue up, using

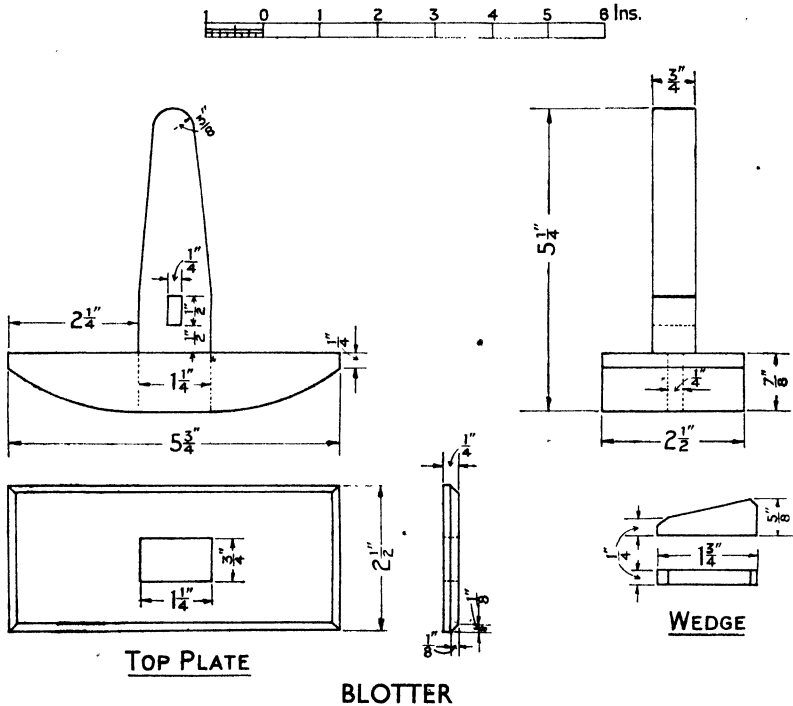

a notched cramping piece to take any projecting tenon. Make sure the stem is square with base.

Glasspaper both sides of ply and set out the 1 1/4 in. by 3/4 in. mortise in middle. Bore two 1/2 in. holes, chisel, file to size. Slip plate into position, and cramp plate and base together in vice edgeway up. Plane until edges register. Invert and repeat. Still keeping plate on base, mark ends; saw and shoot to length. With iron plane work the bevels, or omit them, and inlay a coloured band along the edges.

From a scrap of pine about 4 in. long make wedge and glasspaper it.

The underside of the base must now be cleaned off and smoothed. Clean off the whole with glasspaper.

Hat and Coat Rack—

MAHOGANY, OAK, OR CANARY

1 piece 10 in. × 4 in. × 1 in.
 ,, 12 in. × 1 5/8 in. × 1 in.

Average time 10 hours

The curved ends of the back are worked with coping saw, chisel, and glasspaper, while the curved chamfers are cut with spokeshave

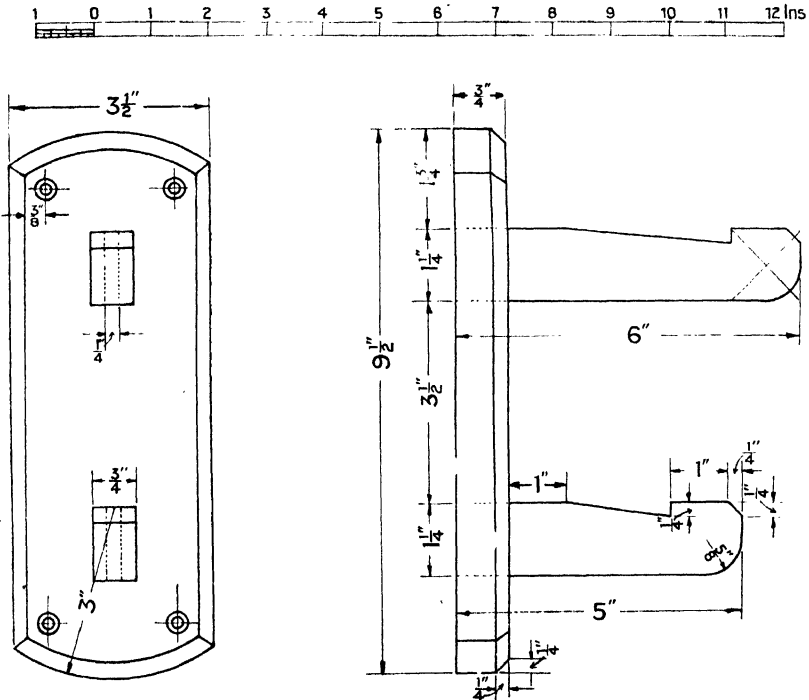

HAT AND COAT RACK

and finished with file and glasspaper. The long chamfers are planed, or contrasting bands inlaid on the front surface.

The piece for the pegs is planed, ends shot, and tenons worked on them. The curves are vertically chiselled and glasspapered. The pegs are cleaned off and glasspapered before assembly.

A notched cramping board is used when gluing up, care being taken that the pegs are in alignment, and square into the back.

Dovetail Exercise—

HARDWOOD

9 in. \times 2 $\frac{1}{2}$ in. \times $\frac{3}{4}$ in.

Plane up, and shoot both ends. Set the cutting gauge to the thickness of the stuff and gauge a line across both faces at one end

and all round at the other. At the first end, set out the pins with the bevel, or templet, and small square. Shade waste. Saw and chop out with firmer chisel and mallet, undercutting slightly so as to produce a slightly hollow floor to the socket. Saw this piece of wood to length.

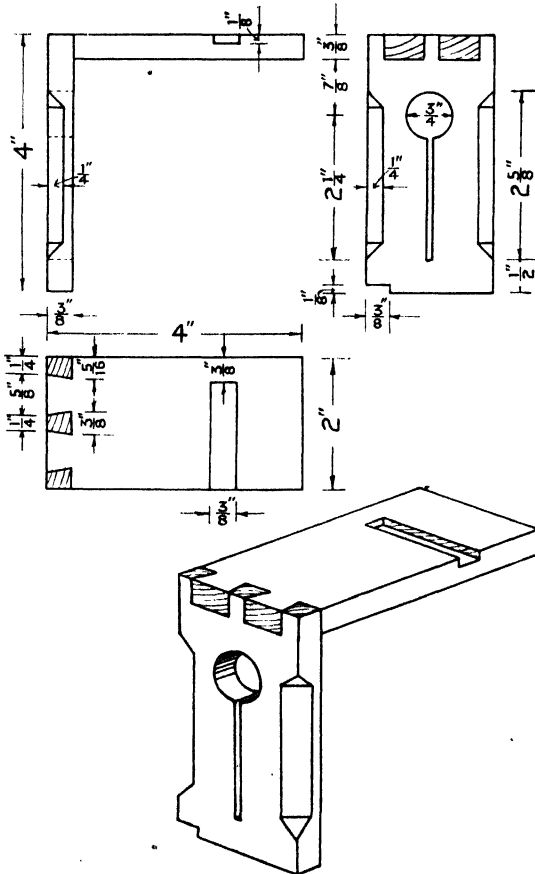

DOVETAIL EXERCISES

Using the pins already made, or the templet, set out the dovetails, scribing them with a fine scribe. An old compass leg is ideal. Saw on the waste side of the slopes, just touching the line. Chop out the middle piece and saw the shoulders as usual. If successful,

the fitting can be postponed. If unsuccessful, another set of dovetails can be made.

Set out the stopped housing on the dovetail piece, using knife and gauge. Work this by one of the methods suggested for cutlery box. With centre-bit bore the hole, and saw the slot with pad saw or compass saw. With thumb gauge set out chamfers, and work

them with chisel and mallet. Finish with file and glasspaper. Set out and make the shoulder on the end of this piece with cutting gauge, saw and chisel, treating it as if it were any ordinary joint shoulder.

Clean off, and fit the dovetail and the stopped housing. Both joints should be a tight knock-in fit.

Teapot Stand—

OAK, MAHOGANY OR WALNUT

2 pieces 13 in. × 1½ in. × ¼ in.

1 piece 6½ in. × 6½ in. × ¾ in.

Average time 11 hours

The frame pieces are planed up and their ends shot. The length is measured from each end, and the pieces sawn and shot square.

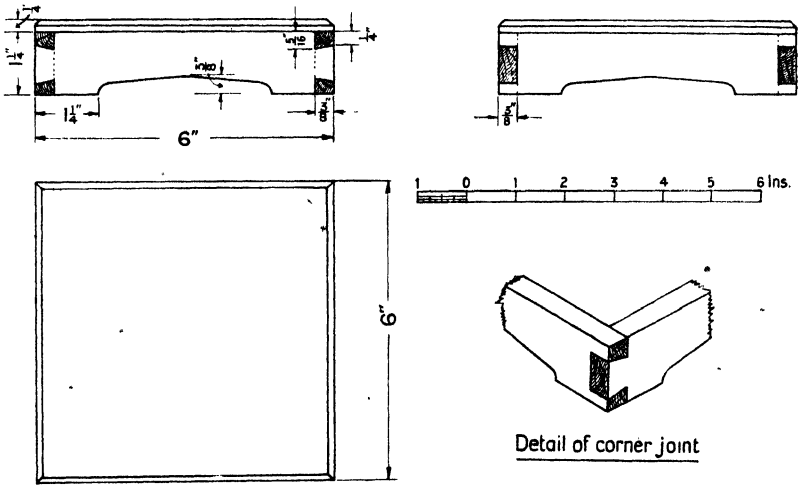

TEAPOT STAND

Set cutting gauge to thickness of material and cut lines around both ends of two pieces, and the broad sides only at the ends of the other two. With bevel or templet set out pins on pieces gauged on broad side only. Shade waste and saw. With firmer chisel and mallet chop out sockets from both sides, undercutting slightly. Set out dovetails from the pins or templet, and saw the slopes. Deepen shoulder lines, nick in and saw. Fit the joints, numbering each inside on both pieces *with scribe or bradawl*. While assembled,

mark out the decorative clearance for feet. Work with coping saw, etc., Clean inside and glue up.

Plane face side of top and gauge and plane to thickness only. True up top of frame, resting the tail of the plane on the member which is square with the member being planed so as to get a shearing cut. This obviates planing the edges out of square and splintering. Glue top of frame and underside of top, and cramp up. When glue is set, plane ends of the top flush with sides, working towards the middle. Similarly plane edges flush with frame.

Any decoration to top can now be added. Linseed oil is almost the only suitable finish.

Tea Tray—

ANY HARD WOOD

2 pieces 18½ in. × 1½ in. × ½ in.

„ 14½ in. × 3 in. × ½ in.

1 piece ply 18½ in. × 14½ in. × 5 mm.

Average time 15 hours

Is jointed exactly as last exercise. The handholes are afterwards worked with brace and bit, compass saw, file, and

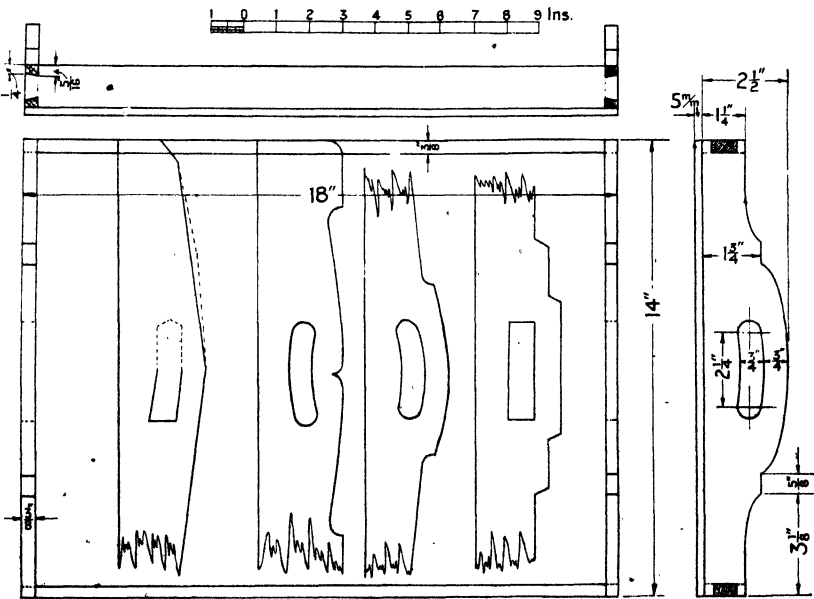

TEA TRAY

glasspaper. The end curves if not geometrical may be set out with templet.

The bottom can be screwed on or pinned with $\frac{3}{4}$ in. panel-pins. The latter are almost invisible, easy to fix, and capable of carrying any reasonable weight.

A heat and damp resisting finish is desirable.

Plate Drainer—

- 2 pieces 20 $\frac{1}{2}$ in. \times 2 $\frac{3}{8}$ \times $\frac{1}{2}$ in.
- 2 ,, 6 in. \times 2 $\frac{3}{8}$ in. \times $\frac{1}{2}$ in.
- 2 ,, 6 in. \times 2 in. \times $\frac{3}{8}$ in.
- 1 piece 6 in. \times 1 $\frac{3}{8}$ in. \times $\frac{1}{2}$ in.
- 1 ,, 9 $\frac{1}{2}$ in. \times 5 $\frac{1}{4}$ in. \times 1 in.

This introduces the double dovetail. The joints are made first, the level of the serration tops sawn with compass or coping saw,

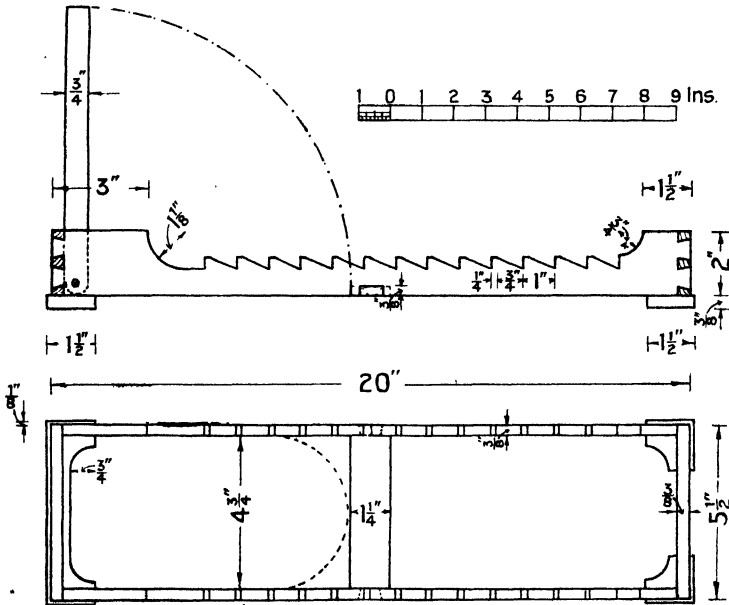

PLATE DRAINER

and the serrations cut with chisel and tenon saw. The stretcher piece is jointed and the whole glued up. The pivoted support is

shaped with spokeshave and fixed with brass screws. Fix the feet with fine brass screws.

As this article is regularly exposed to moisture, any polish is superfluous. It must be oiled or left in the white.

This is a useful, handy article which can be hung on the nearest hook when out of use.

Cutlery Box—

- 2 pieces 14 in. \times 2½ in. \times ½ in.
- „ 7½ in. \times 2½ in. \times ½ in.
- 1 piece 14 in. \times 3½ in. \times ½ in.
- „ 14½ in. \times 7¾ in. \times ½ in. or 5 mm. ply.

Average time 13½ hours

A suitable wood is oak or elm; either of which will stand repeated scrubbing without losing its appearance.

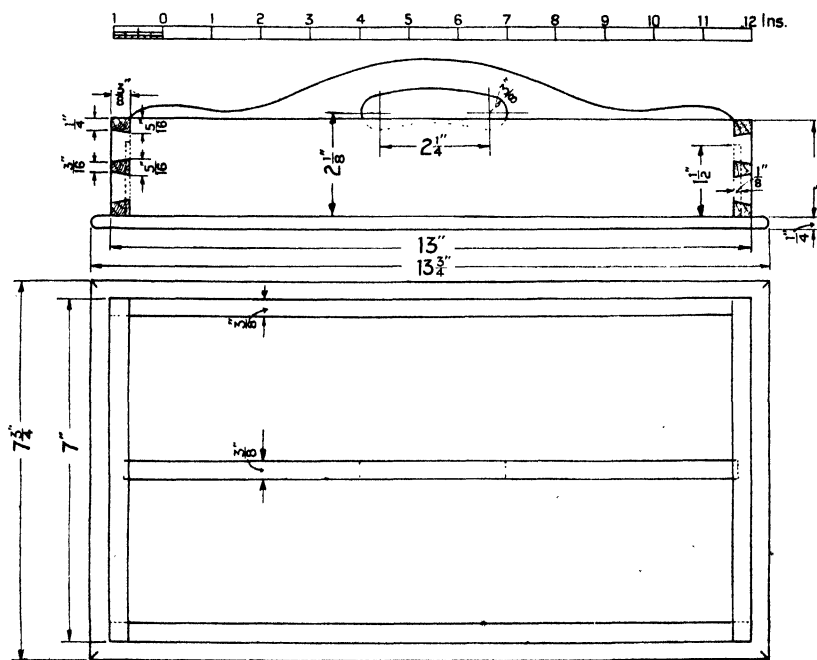

CUTLERY BOX

The end and sidepieces are planed and shot to length. The double dovetails are made and fitted. *While the box is assembled*, set out the stopped housing joints with the knife and gauge. Chop these out with the 1 in. chisel and the $\frac{1}{4}$ in. chisel. An alternative method is to mortise out a piece the width and depth of the notch at the stopped end. Then nick in the notch lines and saw to depth, finishing off with the chisel and router. Glasspaper the inside and glue the carcase together.

Plane the partition handle and shoot to length. Set out and make the curve and hand hole as in last model. Now fit the housings and mark the shoulder lines *in situ* with a thin knife blade. Saw the shoulder and fit the handle dry.

The bottom can be made of ply, but if solid wood is preferred it should be planed to thickness only, the carcase laid on it in the middle, and two pencil dots marked inside at the two diagonally opposite corners. Drive partially into the bottom two small pins on the pencil dots. These will position the carcase. Round the outside and the inside draw fine scribed lines. Remove the framework, and on the base draw parallel lines for the projection. Work to these lines and nose the edge with plane and glasspaper.

Clean outside of carcase with plane and glasspaper and fix bottom with fine pins or fine screws. If the bottom is to finish flush with the sides, the outside cleaning should be left until the bottom has been fastened. No screw or pin heads should project, or everything upon which the box is laid will be scratched.

Now pull out the registering panel-pins.

Variations in the shape of the handle, number of compartments, etc., are suggested to give variety. The handles may be at the two ends and the inside lined with baize glued down. A sheet of baize can also be glued on the underside of the bottom.

Double-stopped Housing Exercise—

1 piece 7 in. \times 3 in. \times $\frac{1}{4}$ in.
 ,, 5 in. \times 4 in. \times 1 in.

Plane up the uprights and from each end set out the halving joint with marking gauge and cutting gauge. Saw and chop out.

Plane up and shoot base. With bevel and knife set out the housing joints. Chop them out with 1 in. chisel held parallel to the long

lines. Deepen with $\frac{1}{4}$ in. chisel and adjustable router to required depth. Set out and work the shaping exercises which are all common decorative woodwork features. Clean off, fit, and glue together.

Inkstand. The exercises here are the two double-stopped housing joints, set out with bevel and knife, and worked with mallet,

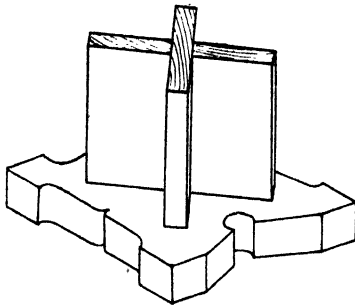
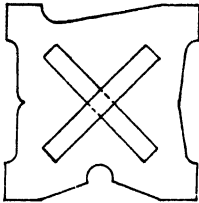
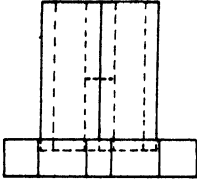

DOUBLE STOP—HOUSING

chisels, and adjustable router. The uprights are glued into position and screwed from underneath.

The shapes and treatment of the base shown in the drawing are suggestions only. Shaping, chamfering, and inlaying are all suitable. Carving, however, is not, as it would gather dust. If the wood chosen has a good grain, any decoration may be superfluous and in bad taste.

The inkwell holes should be made to fit the inkpots brought to school by the maker of the model. They should be bored with a Forstner bit and shaped with a chisel.

French polish finish is suggested.

Book Troughs—

Average time 14 $\frac{1}{2}$ hours

These are the first articles which lend themselves to effective decoration. The ends can be veneered, inlaid, carved, pierced, or punched. Bands, strings, and "stuck-on"

mouldings are very effective. They may be used on all the members. By altering the proportions and shapes a pleasing variety can be obtained. Any suitable hard wood may be used, and the decoration should be fit for the wood.

The routine for all is similar. The ends are planed up in one piece, and a right-hand and left-hand setting out done by means of a templet unless the setting out is geometrical and there is every chance of accurate work.

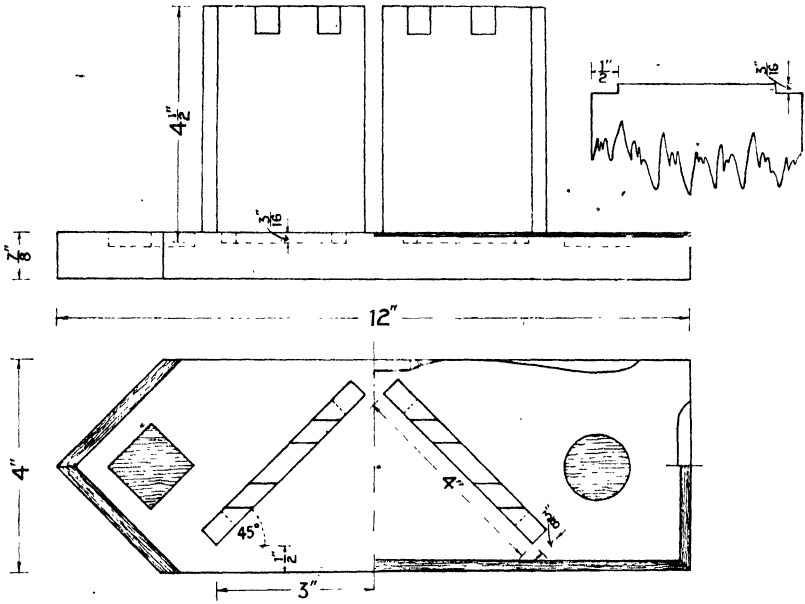

INK STAND

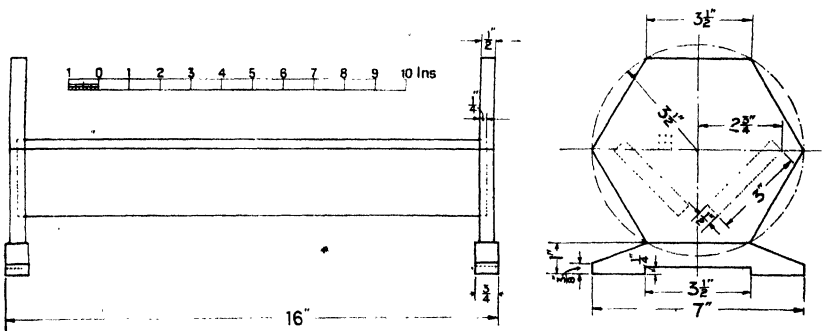

BOOK TROUGH

The double-stopped housing joints are worked with 1 in. chisel, mallet, and adjustable router. The ends are now shaped, decorated, and finished off. If feet are to be added they are made now.

The shelves must be made and fitted, any decoration added and finished off.

If any colouring is to be done it must be done at this stage. If a water stain is to be used, the grain of the wood must be raised with hot water, allowed to dry, and papered off.

A stout cramping board is needed for each end. The trough is glued, cramped up, and left to set. Care must be taken that the ends are square with the shelves. The surplus glue is cleaned off and the whole glasspapered.

The finish will depend upon the wood and the decoration, but French polish is usually suitable.

Swimming Certificate Frame—

2 pieces satin walnut	11½ in. × 1½ in. × 1 in.
1 piece „ „	10 in. × 1½ in. × 1 in.
„ „ „	10 in. × 2¼ in. × 1 in.
2 pieces „ „	13½ in. × 1½ in. × ¾ in.

Average time 14 hours

This frame fits the swimming certificate issued by the local authority. In setting out dowels extreme accuracy is required and a template may be necessary. This can be made by the boy from sheet zinc with the centres indicated by pierced holes drilled with a jeweller's drill or punched through with the scribe point.

Plane up the stiles and rails. Set out the holes in the stiles with a template or with gauge and pencil. Bore the holes 1 in. deep with a twist bit, using a depth gauge. Gauge line ¼ in. from the face side on the face edge and on the back from the face edge. Set the fillister plane to the correct dimensions and rebate the stiles.

Shoot the rails to length, i.e. ½ in. longer than the daylight opening. Set out and bore the holes 1 in. deep. ¼ in. from each end cut lines around with cutting gauge. Using the same setting, gauge lines from the face side on the ends. Deepen the shoulder lines, nick in and saw the shoulders, slightly undercutting. A simple chisel cut will now split off the waste.

Make any necessary adjustments and glue up square and out

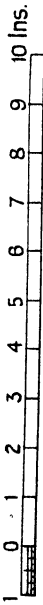
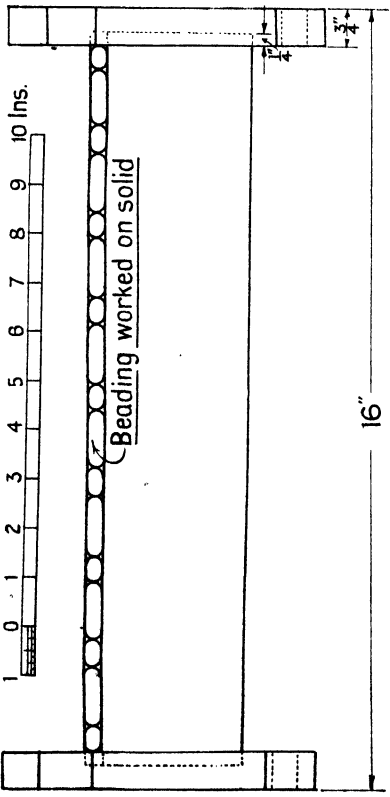
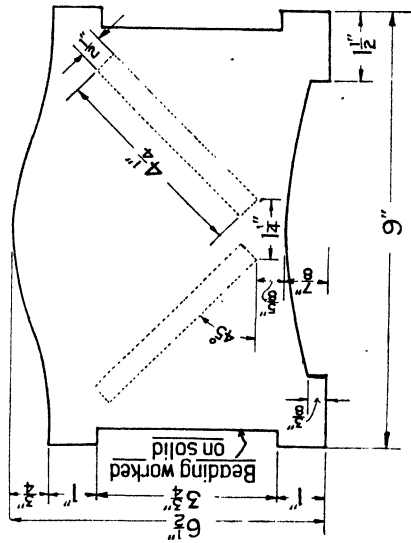

BOOK TROUGH

of wind. A shaving should be taken off the dowels to prevent splitting or a vee taken out with a carving chisel for the same purpose. The dowels should be $\frac{1}{8}$ in. shorter than the combined depths of the registering holes. In this case this will be $1\frac{1}{8}$ in.

Work the capping pieces; plane up the frame, glasspaper, and

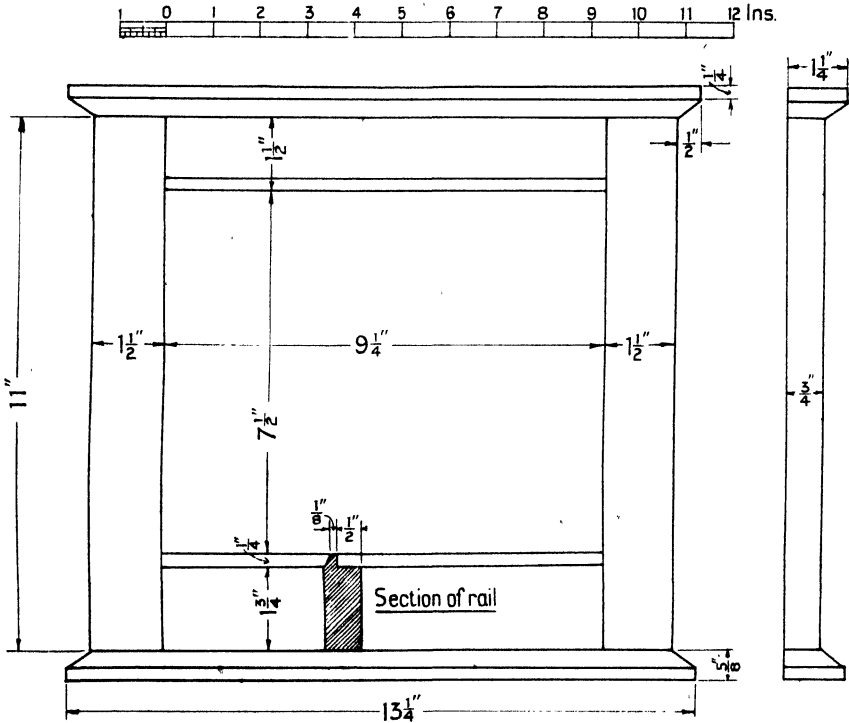

SWIMMING CERTIFICATE FRAME

fix the caps with dowels or headless panel-pins and a touch of glue. Cramp them down and leave to set.

No decoration is suggested, while the finish should be simple and suitable for the wood and the certificate.

Mirror Frames—

Average time 22 hours

The three frames are variants which introduce the dowel joint. They are given in descending order of difficulty. As there is little strain on the joints the dowel joint is as suitable as the mortise joint.

The usual mirror fittings are absent, as they have to be bought and are seldom satisfactory.

All the frames are made as in the last exercise.

A

Plane up and joint the stuff for the tray, making the dovetails on the back piece. Set out and work the bridle notches on the wings.

Plane up the stuff for the posts to $1\frac{1}{2}$ in. by 1 in. section; set out the bridle, and saw and chop out. Fit these joints and glue up the tray, making sure that it is square and out of winding.

While the glue is setting, shape the posts and add the decoration.

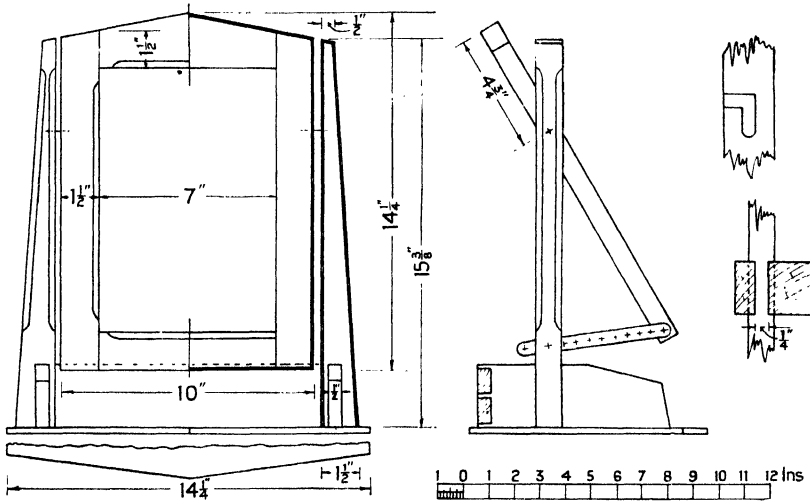

ADJUSTABLE SWING MIRROR FRAME AND TRAY

The frame can be hinged by drilling the posts and screwing $1\frac{1}{4}$ in. by 8 brass screws loosely through them but tightly into the frame. Alternatively, hardwood dowels may be glued into the stiles and cut to length. One of these fits into a hole bored into a post while the other slides into place along a slot similar to that illustrated. The hinging must be accurate or the frame will tilt drunkenly. The bottom, which may be of plywood, must now be shaped.

Clean off the tray inside and out, push the posts home and set accurately on the bottom. Scribe a fine line round the tray inside and out, and, from the top, drill the screw holes. Countersink these

from underneath. Register the tray with a couple of fine panel-pins in the corners and screw on the bottom. Screws can be driven into the bottoms of the posts. This, however, should be unnecessary, because if they fit tightly they will be quite rigid, as the buttress shape will prevent them from leaning outwards, and they cannot

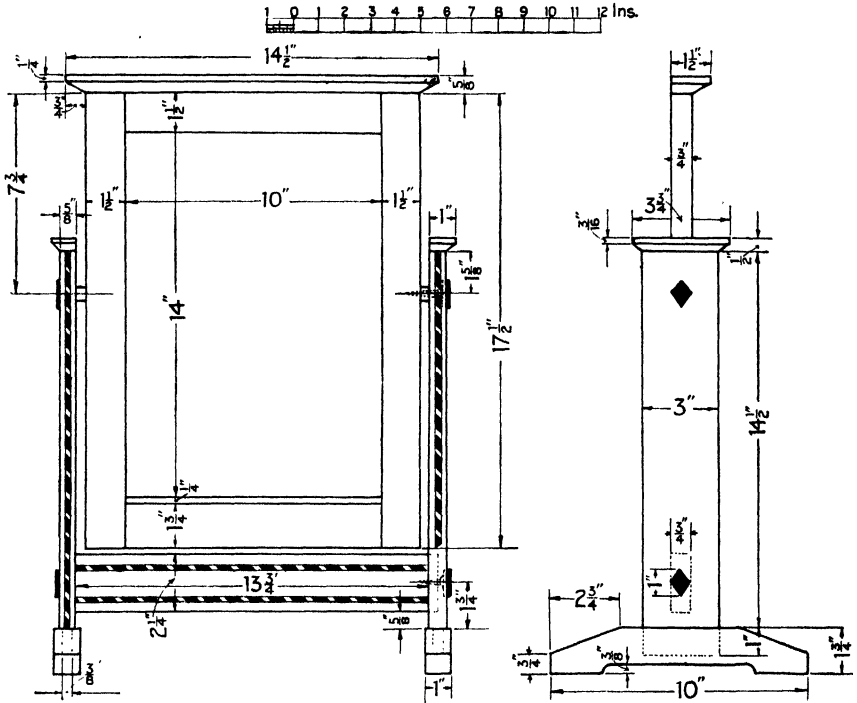

ADJUSTABLE SWING MIRROR

lean inwards. If the posts are fitted dry, the whole can be dismantled and will pack flat when not in use.

Two kinds of decoration are illustrated. The chamfers on the left are worked with chisel, mallet, file, and glasspaper, while the black (or any contrasting colour) line decoration calls for the cutting gauge.

The positioning piece can be a "Meccano" bright strip screwed loosely to the frame and hooking on to a round-headed screw in the post. If enough equipment is available it is better to make it of phosphor-bronze, brass, or other material about $\frac{3}{8}$ in. thick.

B

After the frame is made and decorated, the supporting frame must be jointed. The cross-piece is mortised full width and thickness into the uprights, glued and fastened by screws, whose heads are covered by ornamental pieces of contrasting wood. These may be fitted dry and allowed to project slightly. The uprights are tenoned into the feet before the latter are shaped. The caps are dowelled into position. Before being finally glued together the decoration must be done.

The frame is hinged with brass flat-headed screws. The heads are hidden by insets of wood similar to those below. Two distance-pieces of brass tubing are slipped over the screws before they are driven home.

The positioning strip is made and fitted as in the "A" exercise.

C

This is a useful travelling companion, large enough for dressing and shaving. It should be made of some light-weight wood.

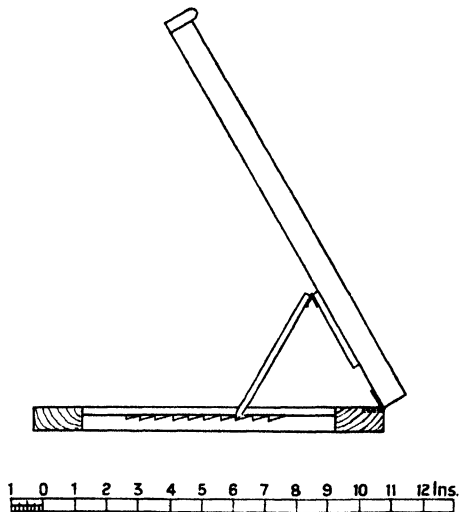
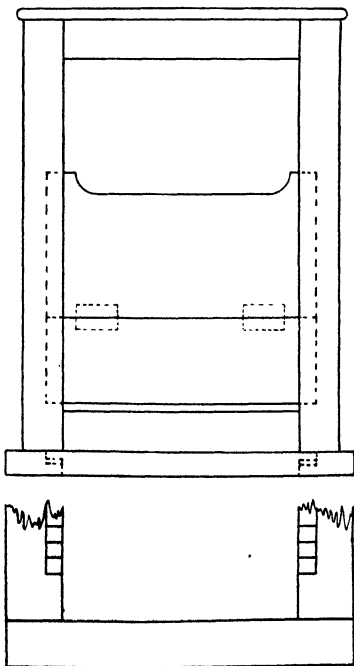

TRAVELLING MIRROR

The front elevation shows the plywood strut turned up for packing, while the side elevation shows it in its working position.

The base frame is bored for the dowels and rebated afterwards. The serrations may be made at any time, but preferably before the frame is glued up.

The frame is hinged to the base with a pair of $1\frac{1}{4}$ in. brass butts sunk full depth into the latter.

No decoration is suggested. The bevel on the lower rail will not collect dust to the same extent as if its top edge were square.

In fitting frames with mirrors it is usually advisable to blacken the inside of the rebate with Indian ink so that the raw wood is not reflected by the mirror. The glass can be positioned with strips of blackened cardboard or triangular section slips of soft wood pushed between the glass edge and the frame. It is also usual to cover the back of the silvering with several sheets of brown paper or card to absorb moisture. A plywood back overlapping on to the frame can then be screwed down with No. 2 screws.

CHAPTER XV

DISCIPLINARY EXERCISES

THE following exercises are intended to be used as a basis for tool drill, and are purely disciplinary. They are graded in order of difficulty, embrace essential joints used in the manual room and involve all the primary tool operations.

Experience has proved their worth, not only in regard to time and timber, but for collective and individual drill and demonstrations. Two variations of each joint are embodied in each exercise, which can be executed in yellow pine, red deal, or canary wood, except in the case of the dovetail joint—in this case hardwood could be introduced with success, using satin walnut, or mahogany.

The Housed Joint—

Sawing size: 10 in. × 2 in. × 1 in.

1. Pick the better broad side for the Face Side, plane flat and smooth, test with eyes, fingers, and steel rule. Put on Face Side. Mark sloping in the direction of the grain. (See illustrations.)

2. Plane the Face Edge straight, and square with the Face Side. Test with eyes, fingers, and try square, put on Face Edge Mark thus: 

3. Gauge to width allowing $\frac{1}{16}$ in. extra for cleaning off.

N.B. Introduce gauge drill. Plane to middle of gauge line and test.

4. Gauge to thickness allowing $\frac{1}{16}$ in. for cleaning off. Plane to middle of gauge line and test.

N.B. When sufficient experience has been acquired, the allowance for cleaning off can be reduced to a minimum.

Each stage of the planing should first be demonstrated and completed before the next is attempted. Common faults can be checked, the errors pointed out and corrected before the whole class.

From the illustration it will be seen that there is $\frac{1}{4}$ in. of waste wood at each end. This allowance is to enable the ends to be sawn square before the setting out is done. All gauge lines for notches, mortises, tenons, etc., must be done from the Face Side or Face

Edge, as the case may be. All lines which are to be sawn across the grain should be well cut in with the striking knife and a notch taken out with the 1 in. chisel. These notches or nicks are shown on the drawings by horizontal shading.

Demonstrate first the squaring of a line around the wood, shading and sawing off the waste ends. When the ends have been

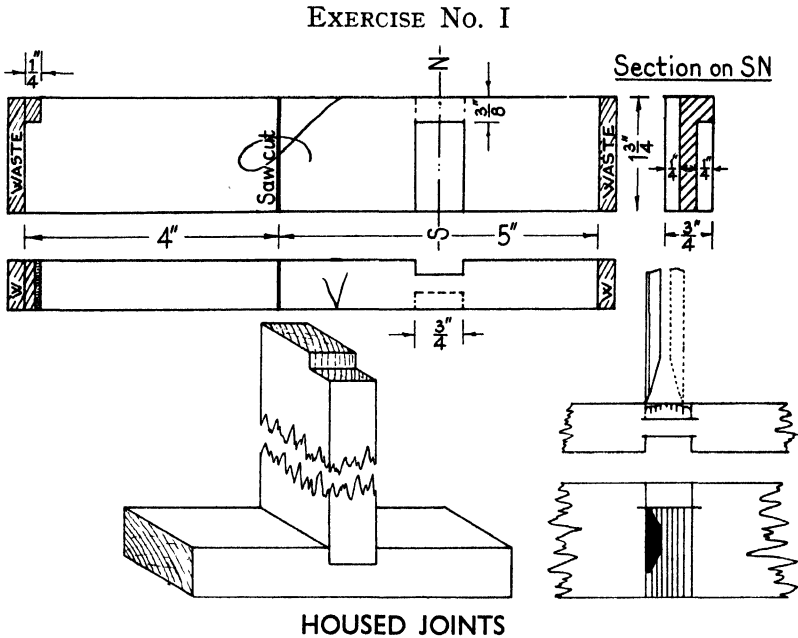

satisfactorily sawn, demonstrate the setting out of the exercise, wholly or in part. The cross sawing should be done on the Bench Hook, but for the horizontal chiselling, the wood must be held in the Bench Vice.

Fig. 1 illustrates the method of cutting in the stopped housing with the 1 in. chisel. Fig. 2 gives a pictorial view of the through housed joint assembled.

Great care and attention must be taken in cleaning off, as it is easy at this stage to spoil all the previous work.

Joints should be made to fit without the aid of glue, screws, wedges, etc.

N.B. To avoid repetition, it should be clearly understood that

in sawing to gauge or cut lines (with or across the grain), the saw should touch the line on the wastewood side. If parts that are to be cut away (waste) be clearly indicated on the setting out, unnecessary mistakes will be avoided.

Halving Joints—

(LAP AND CROSS HALVING)

Sawing size: 13 in. × 1½ in. × 1 in.

Planing up as in previous exercise.

Saw ¼ in. wastewood off each end before setting out.

Set out as illustration, shade wastewood and cut in all V notches.

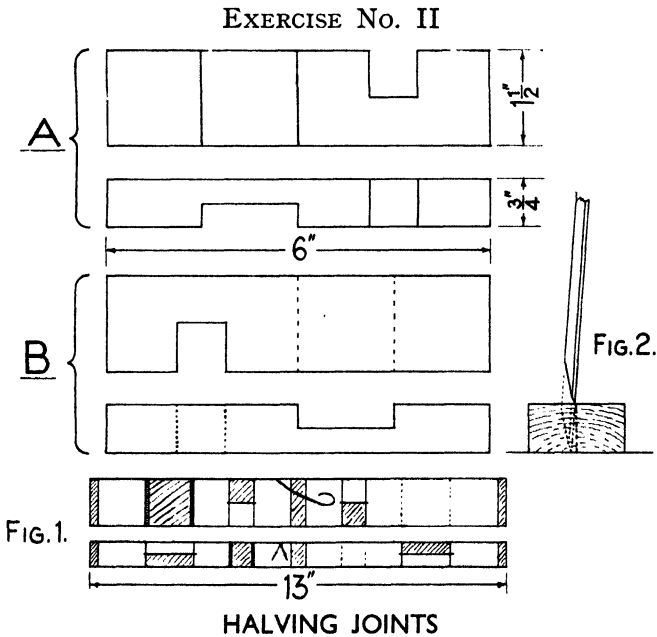

It is essential that the gauging for the lap notches be done from the Face Side only; although the notches are set out on opposite sides it is necessary to leave in on one side as much as is cut out on the opposite, so that the surfaces will finish flush.

Similarly, the cross notches must be gauged only from the Face Edge. Saw the notches to the cut lines with one or two extra saw cuts in the wide notches to ease the chiselling, which should be done

with the 1 in. chisel from the opposite edges, the last chisel cut to be in the *middle* of the gauge line. Fig. 2 shows how the $\frac{3}{4}$ in. notches can be chiselled vertically on the cutting-board or bench hook if the surface of the latter is reasonably flat. Saw to correct lengths, clean off and fit together. Use a piece of wastewood when knocking together to avoid hammer-marks on the finished work.

The drawings *A* and *B* show the pieces separated ready to fit together. Fig. 1 shows the maximum length before the ends have been sawn square, also the complete setting out.

Dovetail and Tee Halving. In the two previous exercises all the sawing has been done across the grain.

The most difficult joints in woodwork are those which involve sawing parallel with and obliquely to the grain, e.g. mortise and tenon, dovetail, etc. This exercise includes the above-mentioned difficulties in sawing.

Sawing Size: 13 in. \times 1 $\frac{1}{4}$ in. \times 1 in.

Plane up and saw ends square as in previous exercises. Set out as in illustration omitting the notch for the dovetail half-lap. Shade all wastewood. Cut in V notches and gauge. Saw lap joints at each end, saw and chisel out parallel notch, after which the piece can be divided. When sawing the longitudinal cuts at the ends, place the wood vertically in the vice so as to grip the edges. Any risk of the wood slipping will now be obviated. The wood must not be placed too high in the bench vice or the cramped position of the worker will result in bad work. Start the saw cut at the far end of the line using the tip of the thumb as a guide, the saw to touch the gauge line on the waste side. Commence with the right hand saw cut; the worker will then have the wastewood on his right-hand side and should saw from the opposite edge across the end and down to the shoulder line on the edge facing him. Reverse the wood and repeat for the other saw cut the result will be diagonally opposite saw cuts (see sketch *A* which illustrates the method of sawing a tenon). Finally bring the saw into the horizontal position and saw down to the shoulder line. This method minimizes the risk of running off the line on the side away from the worker.

N.B. In the case of a left-handed boy he would naturally have the wastewood on his left-hand side and would commence with the left-hand line.

Sketch *B* shows the method of sawing tenons, etc., usually adopted by skilled craftsmen but is not recommended for boys' use. Experience has proved this method unsuitable, as the boy finds it

EXERCISE NO. III

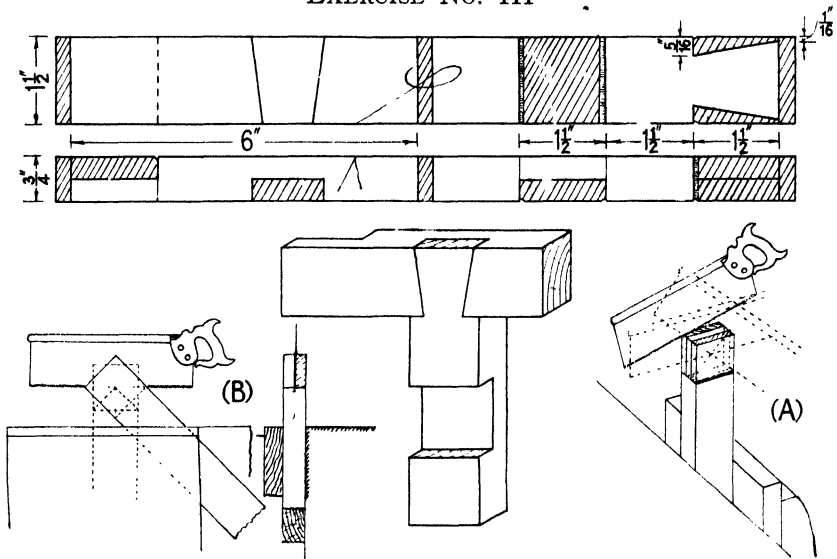

DOVETAIL AND TEE HALVING

very difficult to watch and saw two lines at once; i.e. the lines on the end and on the edge. Another objection is the risk of movement in the vice due to faulty planing.

It will be advisable when sawing the sloping sides of the dovetail to tilt the wood in the vice sufficiently to bring the line into the vertical position; this will simplify the operation and ensure better results.

Mark the notch for the dovetail-lap lightly with the striking knife from the dovetail itself; cut in deeper, take out V notch and proceed as in previous notches.

In cleaning off the piece containing the dovetail notch, great care will have to be taken with the face edge. If more than one or

two shavings are taken off, the narrow part will be enlarged, resulting in a bad fit. Any extra shavings can be taken off the opposite edge without affecting the joint.

Mortise and Tenon Joints. This joint with its variations is one of the most extensively used in woodcraft. The drawing depicts one of the simplest forms, and is known as a "through" M and T. The stub or stump tenon which only enters a certain depth is mostly used in cabinet work. The chief variations are the haunched tenon.

EXERCISE NO. IV

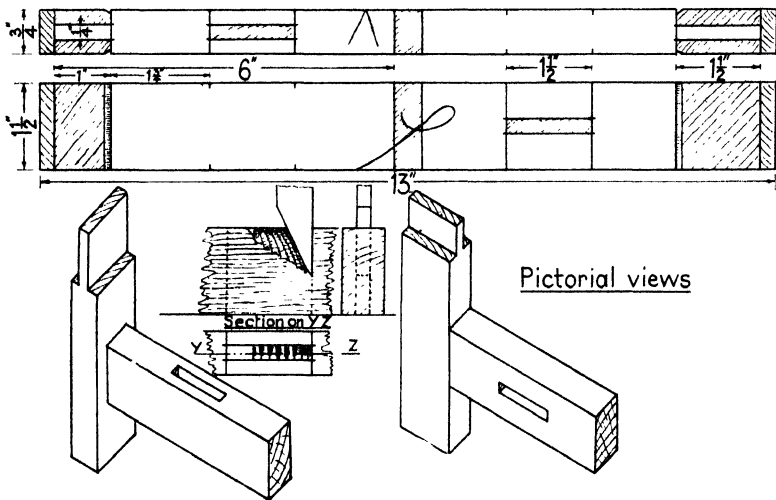

MORTISE AND TENON JOINTS

pair of single tenons (used in the middle and bottom rails of doors), pair of double tenons (used in extra thick stuff), "barefaced" tenon (has one shoulder only), long and short shouldered (used for rebated wood or glass panels). The best proportions for the tenon are one-third of the thickness, and one-half the width available for tenon in the rail, no single tenon to exceed in width six times its thickness. This exercise introduces three tools which have not been used hitherto—the mortise gauge, mortise chisel and the mallet. To set the mortise gauge use the chisel with which the mortise is to be cut, instead of using a rule; this method ensures greater accuracy as chisels are not always true to standard sizes.

Sawing size: 13 in. \times 1 $\frac{1}{2}$ in. \times 1 in.

Prepare and saw ends square as in previous exercises. Set out and proceed with the demonstration.

Section YZ indicates the position and cutting action of the mortise chisel. Care must be taken to keep it parallel with the sides of the wood as shown in the end view. To do this successfully the worker must be directly behind the chisel and in line with the mortise. Chisel to opposite ends of the mortise slightly more than half the depth; turn the wood over and repeat the process. Remove

EXERCISE NO. V

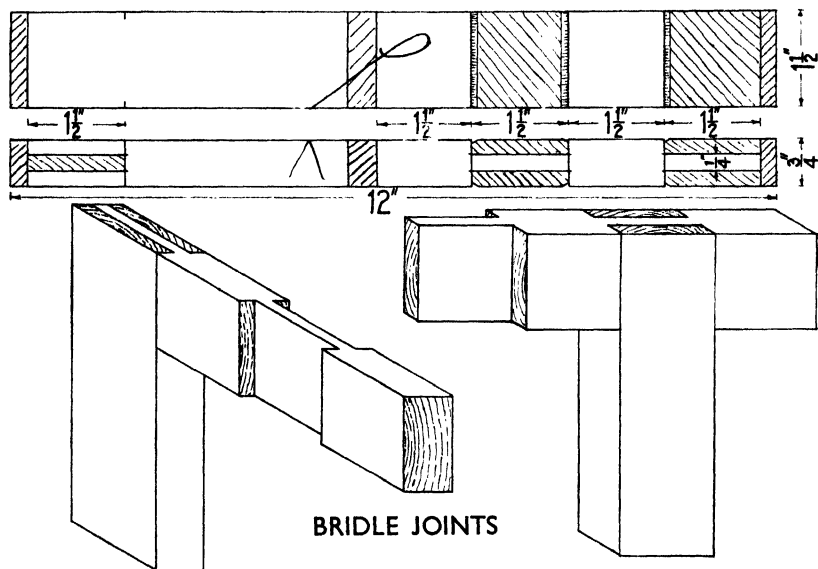

core with a drift, i.e. a piece of hardwood 6 in. \times 1 1/4 in. \times bare 1/4 in. slightly tapered in width and thickness. To saw the tenons proceed as in lap and tee-halving joint, undercutting the shoulders slightly.

Bridle Joints—

Sawing size: 13 in. \times 1 1/4 in. \times 1 in.

The success or failure of this exercise depends almost entirely on careful and accurate sawing along the grain.

Square lines around and saw the ends. From each end measure 1 1/2 in. and square a line all round at one end, but only on the opposite edges at the other end. See sketch (setting out). From the shoulder

line measure three equal distances of $1\frac{1}{2}$ in. and square the lines all round.

Set the mortise gauge and from the Face Side gauge, and shade all parts that are to be cut away.

Cut and nick in the lines for the notches, proceeding as in previous examples.

Dovetail Joint. Hardwood is suggested for this exercise. Sizes can be left to the discretion of the teacher.

EXERCISE NO. VI

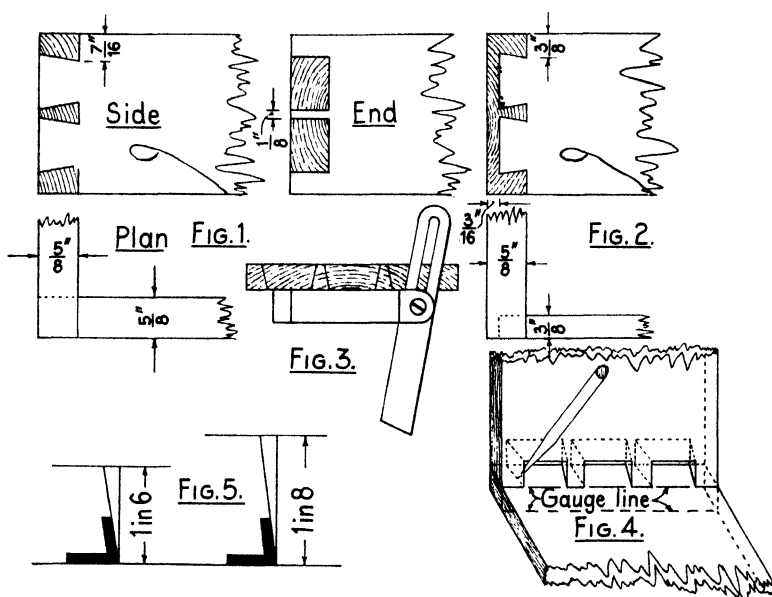

DOVETAIL JOINTS

Fig. 1, side, end elevation and plan show the common or through dovetail; $2\frac{1}{2}$ in. or $2\frac{1}{4}$ in. wide will accommodate three pins and two dovetails comfortably. Fig. 2 shows the lap dovetail, $\frac{5}{8}$ in. for the front and $\frac{3}{8}$ in. for the side.

Fig. 3 illustrates the method of setting out the pins with the slide bevel which has been set from one of the bevels shown in Fig. 5. The piece on which the pins are to be set out should be held in the vice with the Face Side away from the worker—the bevel may be used from either side.

After marking out the pins, the sockets for the dovetails should be shaded (waste); the same precaution should be taken when the dovetails are marked from the pins (Fig. 4), but this time it is the sockets for the *pins* which must be shaded.

Procedure. Plane a suitable piece of wood to width and thickness. Shoot both ends square. With cutting gauge set to thickness, gauge a thin single line all round at the (dovetail) end, and on the sides only at the opposite (pins) end. Mark out pins with slide bevel or templet, and from these square lines to reach the gauge line on the inside only; this precaution will ensure the pins and sockets being parallel, and at right angles to the end. Shade the sockets, saw the pins touching the line on the waste side. Chop out with a suitable chisel from both sides on the bench top. In performing this operation the length of the wood should be parallel with the side of the bench. The left arm should rest on the work while the hand grips the chisel held at the correct angle which is best seen in this position.

If not successful at the first attempt saw off and try again. When the pins have been successfully worked saw the piece in two, mark out dovetails from pins (Fig. 4), square the lines across the end, place wood in vice so that the sloping lines forming one side of the dovetail are vertical; saw these on the waste side of the line and proceed in a similar manner with the other lines. Nick in the lines on the edge and saw off corner pieces, chisel out intermediate sockets with a suitable firmer chisel. Fit together. If unsuccessful saw off and repeat.

In knocking together wide dovetailed surfaces, it is advisable to use a piece of wood long enough to cover the whole range of the dovetails, it will protect the corners of the dovetails, obviate the risk of splitting, and prevent hammer marks.

CHAPTER XVI

A SCHEME OF PLANE GEOMETRY CORRELATED WITH THE WOODWORK SCHEME

THESE exercises form part of a comprehensive scheme of drawing and woodwork in a school which has a practical room. They are linked up with the practical arithmetic, mechanics, and art, and run side by side with the ruler drawing and simple geometrical design given elsewhere in this book.

All the exercises have practical value since they underlie most of the constructional and decorative work in woodwork. Nothing is included because of its value as pure geometry.

After the first few lessons the exercises should be given in problem form.

Preliminary Instrument Work

To Bisect a Line

1. By trial.
2. By bending or folding it.
3. By measurement.
4. With compasses.

Perpendiculars

1. From a point within the line.
2. From without the line.

First with the squares and then with compass. The 3, 4, and 5 method.

Parallels

1. With the squares.
2. With compasses.

Angles as a Measure of Revolution

To copy an angle—

1. With the squares.
2. With compasses.
3. With protractor.

To bisect an angle—

1. With compasses.
2. By parallel lines (a solid angle).

To trisect an angle—

1. By trial.
2. With compasses where possible.
3. With squares where possible.

The Circle

1. To find the centre of an arc.
2. To draw a circle through three points.
3. To describe a circle round a triangle.
4. To inscribe a circle in a triangle.
5. To draw an arc by intersecting lines when the centre of the circle is not available.
6. The angle in a semicircle.

The Tangent

1. To draw by trial.
2. To draw with compasses.

Triangles**The equilateral triangle—**

1. To draw with set square.
2. To draw with compasses.
3. To draw with protractor.
4. To draw as a sixth of a hexagon.
5. To inscribe in a circle.
6. To describe about a circle.
7. To draw given the height.

The isosceles triangle—

To draw from given data with squares and compasses.

The scalene triangle—

To draw from given data with squares and compasses.

Right-angled Triangle

1. To construct with varying data.
2. The 3, 4, and 5 method.
3. Using the angle in a semicircle.

Quadrilaterals

1. Draw a square on a given line with squares and compasses.
2. Given the diagonal.
3. To inscribe a circle in a square and in a rhombus.
4. To describe a circle about a square with squares and with compasses.
5. To draw a rectangle in a circle.
6. To draw a rectangle from its diagonal.
7. To construct a rhombus with squares.
8. To construct a rhombus with compasses.

Ratio and Proportion**Similar triangles**

1. To find a fourth proportional.
2. To find a third proportional.
3. To find the mean proportional.
4. To divide a line proportionally to a given divided line.

5. To divide a line into any ratio.
6. $AB : BC :: X : Y$.
7. Common scales.
8. The diagonal scale rooth, 64ths, etc.
9. Polar diagrams for enlarging and reducing.
10. Distance calculations by similar triangles.

Polygons

Hexagon

1. In a circle.
2. On a straight line, using squares, compasses, and protractor.

Octagon

1. In a square.
2. In a circle.
3. On a straight line.

“Touching” Problems

1. Four circles in a square.
2. Three circles in equilateral triangle.
3. Circle in hexagon.

Enlarging and Reducing by Squaring

Areas

1. Draw various figures with areas equal to other figures.
2. Reduction of polygons to triangles.
3. Simpson's rule.

Pythagoras Theorem

1. Construction of squares to equal (a) the sum of two squares, (b) the difference between two squares.
2. Draw rectangles to equal a square and *vice versa*.
3. To draw squares and rectangles to contain any number of square inches.

The Ellipse

1. To draw by trammel method.
2. To draw by ordinates (intersecting straight lines).

Loci

To trace the path of points moving in simple mechanisms, using tracing paper.

Vector Quantities. Resolution of forces graphically by means of—

1. The triangle, parallelogram and polygon of forces.
2. Bow's notation.
3. Force polygons.
4. Solution of simple roof trusses, etc., graphically.
5. The reactions at the supports of a loaded beam.

Centre of Gravity of Simple Shapes by Drawing

Tracing paper Problems

1. Finding the length of curved lines.
2. Drawing symmetrical figures.

Some Approximate Solutions

1. To draw a straight line equal in length to a given arc of a circle.
2. To mark off on a given circle an arc approximately equal in length to a given straight line.

The above to be worked with instruments and checked with the tracing paper solutions.

CHAPTER XVII

A SHORT COURSE OF INDIVIDUAL CLASSROOM EXERCISES IN SIMPLE SOLID GEOMETRY

No. 1

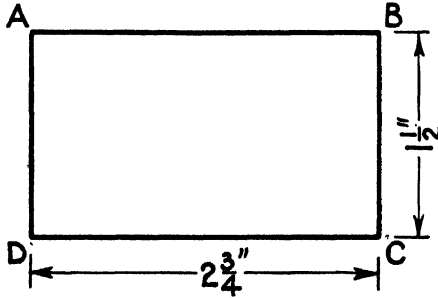

Draw—

1. The P. and E. of the rectangular block shown above. It is $\frac{3}{4}$ in. thick.
 2. The P. and E. when line BC is parallel to the XY line.
 3. P. and E. when line AB is at 30° to XY line.
 4. P. and E. when the block is resting on its end AD with one side at 45° to XY line.
 5. An oblique projection with side CD facing you.
 6. An isometric projection of the solid in any position you please.
 7. A hand sketch of the solid in a new position.
- All drawings to be correctly dimensioned.

No. 2

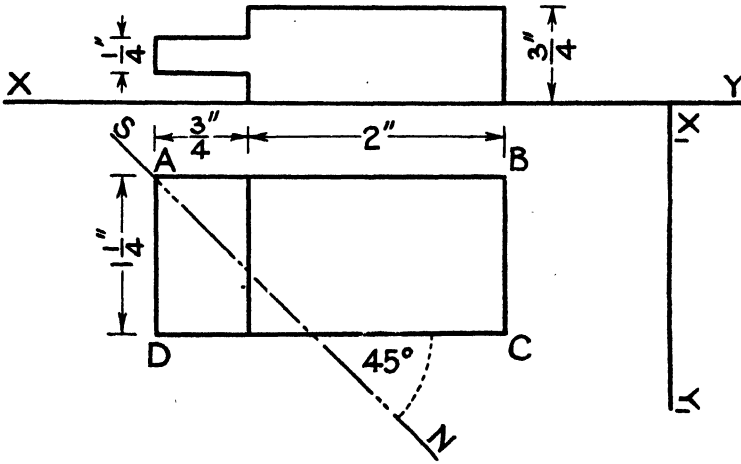

Draw—

1. The P. and E. given.
2. The E.E. on XY .
3. P. and E. when line CD is inclined at 30° to the H.P.
4. P. and E. when the object stands on the end BC .
5. An isometric projection with the end AD nearest to you.
6. An oblique projection with side CD nearest to you.
7. A hand sketch of the object in some new position.
8. A section on line SN .

Dimension the even numbers.

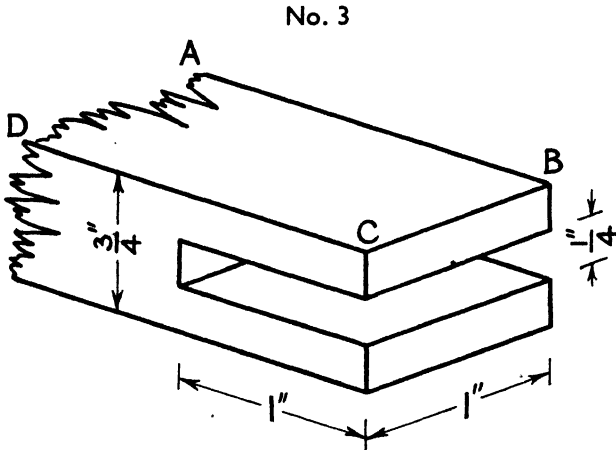

Draw—

1. P. and E. and E.E. showing jointed end.
 2. P. and E., when side AB is at 45° to V.P.
 3. The isometric projection given above.
 4. Oblique projection with end BC nearest to you.
 5. P. and E. when standing on its end with one side at 30° to V.P.
 6. A hand sketch of the other part of the joint.
- Fully dimension drawings 4, 5, and 6.

No. 4

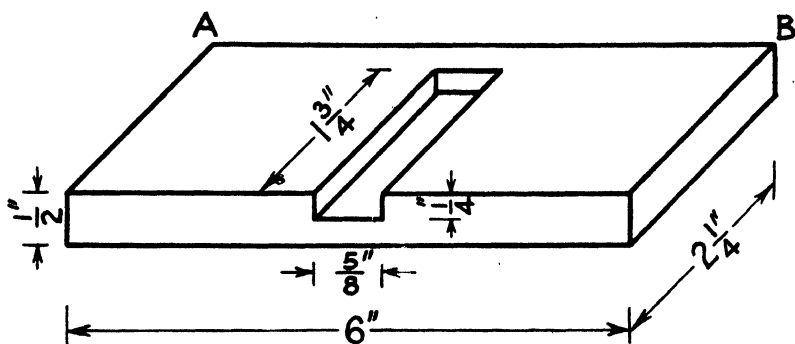

Draw—

1. The oblique projection above $\frac{5}{8}$ size.
2. An isometric projection $\frac{3}{4}$ size.
3. P. and E. with long side at 60° to V.P. Scale $\frac{1}{2}$ in. \equiv 1 in.
4. P. and E. Object standing on its end.
5. A hand sketch of the object.
6. P. and E. with long side AB facing you and the solid resting face down.

Fully dimension drawings 1, 3, 4, and 6.

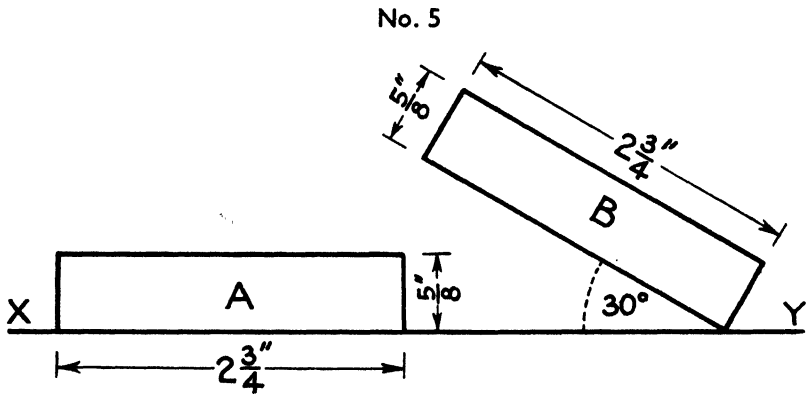

1. *A* is the elevation of a block $1\frac{3}{4}$ in. wide. Draw its plan. Scale 1 in. \equiv 1 in.
 2. Make a hand sketch of it in a new position.
 3. *B* is the same block but tilted at an angle of 30° to the H.P. Draw its plan and E.E.
 4. Make an oblique projection of the solid in this position.
 5. Make an axometric projection in the same position.
- Correctly dimension drawings 3 and 5.

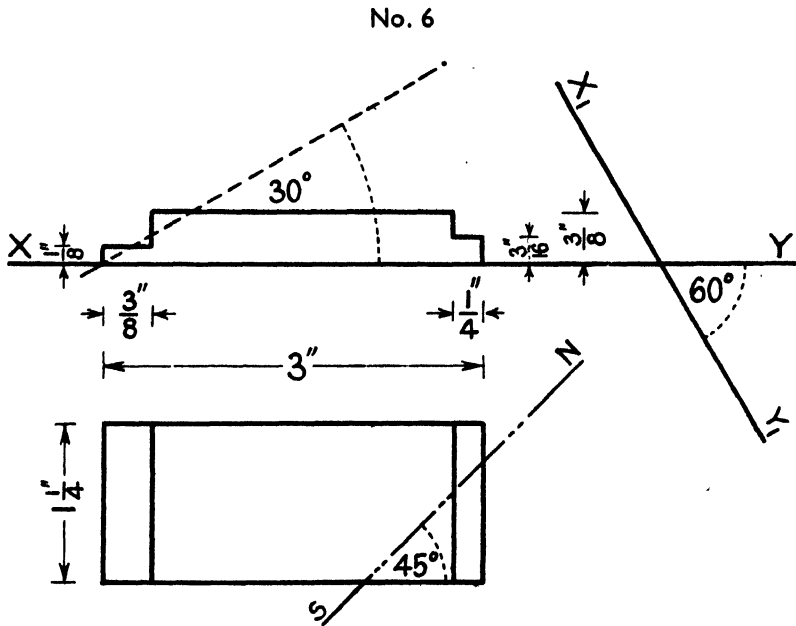

Draw—

1. The plan and elevation given above.
 2. A new elevation on XY , at 60° to XY .
 3. An isometric projection of the solid in this position.
 4. Tilt the solid until it is at 30° to the H.P. and draw a new plan.
 5. A section on line SN .
- All drawings to be drawn to a scale of $1\frac{1}{2}$ in. \equiv 1 in.

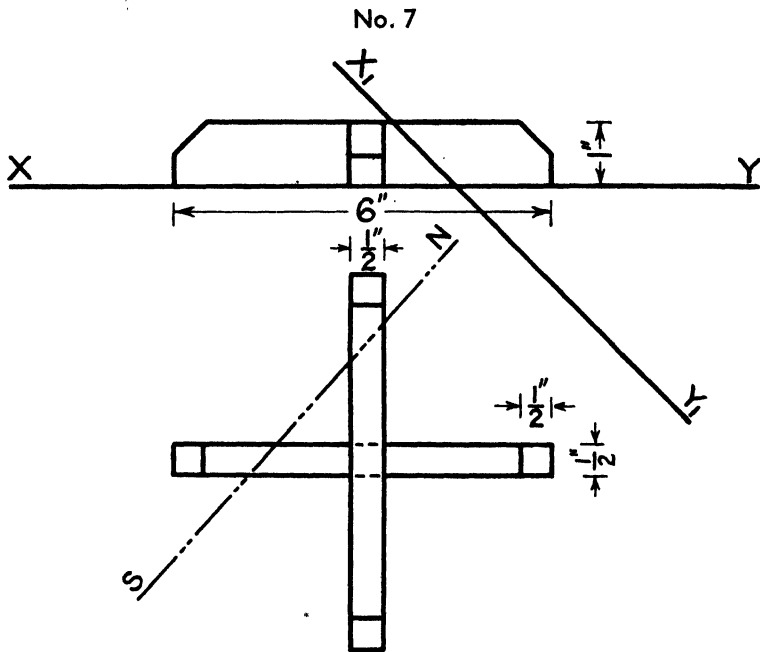

Draw—

1. The given plan and a new elevation on X_1Y_1 .
2. An isometric projection of the stand.
3. An oblique projection of one piece.
4. An axometric projection of the other piece.
5. A sectional elevation on S.N.

Fully dimension Nos. 1, 2, and 4.

Scale $\frac{3}{4}$ in. \equiv 1 in.

No. 8

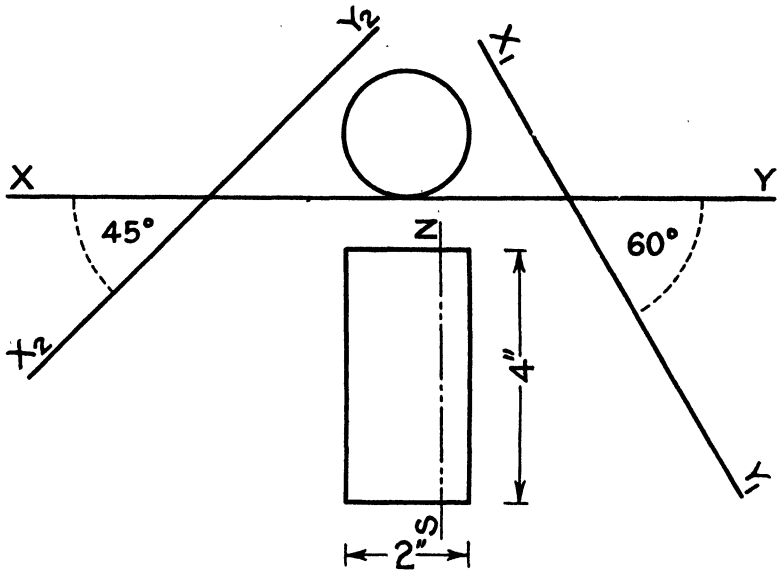

Draw—

1. The given P. and E. of the cylinder.
2. A new elevation on X_1Y_1 .
3. Another elevation on X_2Y_2 .
4. An isometric projection.
5. An oblique projection with the end facing you.
6. A section on line SN .

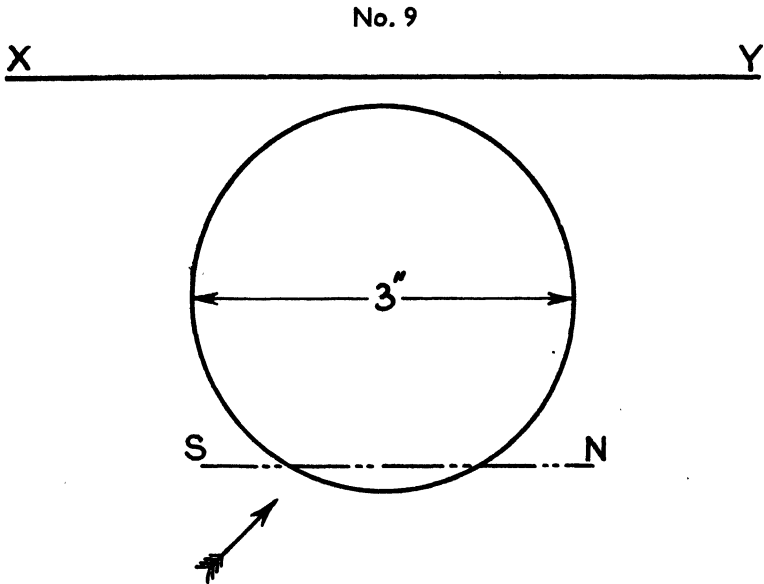

The plan is given of a solid ball (sphere).

Draw—

1. Its elevation on the *XY* line.
2. The sectional elevation on the *XY* line.
3. A sectional elevation on a new *XY*, looking in the direction of the arrow.

No. 10

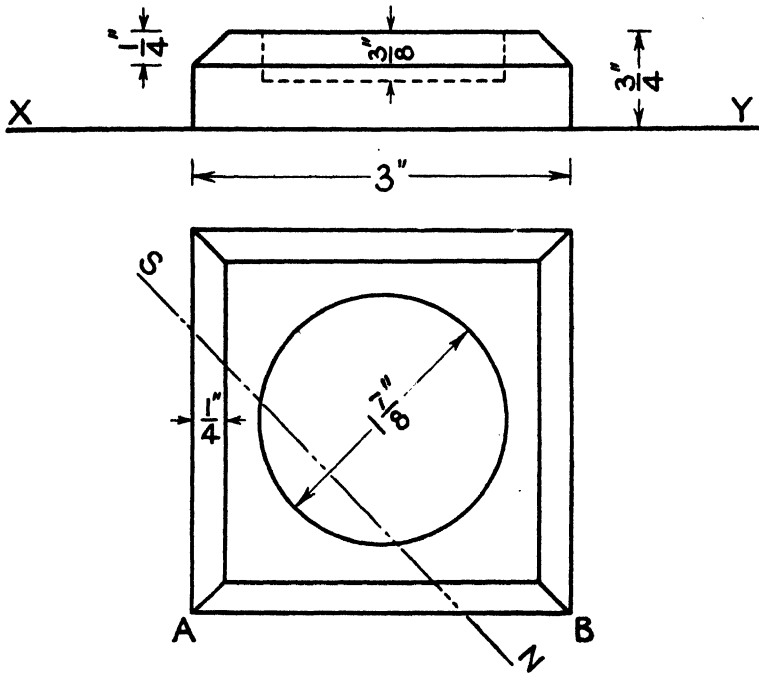

The above is the plan and elevation of a square slab containing a shallow cylindrical hole. The top edges of the solid are chamfered.

Draw—

1. A new plan and elevation when the object is resting on its edge AB .
2. The above plan and a section on line SN .
3. An axometric projection of the solid in any position which shows the chamfer round the top edge.

Scale $1\frac{1}{8}$ in. \equiv 1 in.

No. 11

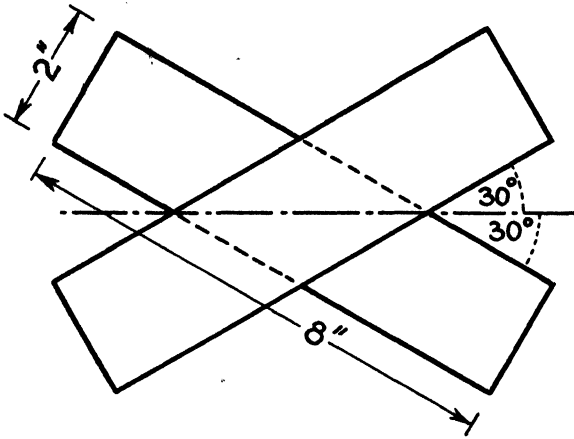

This is the plan of two pieces of wood halved together at an angle of 60° . Each piece is 1 in. thick.

Draw the plan and elevation of each separate piece.

No. 12

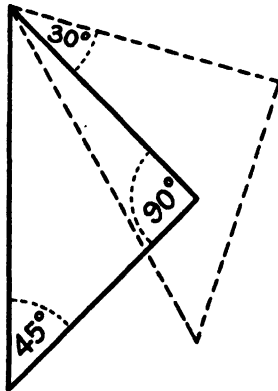

The plan of a 45° set square resting on the horizontal plane is given.

Draw—

1. A new plan and elevation when the square is tilted upwards at an angle of 30° to the horizontal plane.

2. Plan and elevation when the set square is moved into the position shown by the broken line and again tilted upwards at an angle of 30° to the horizontal plane.

CHAPTER XVIII

A SCHEME OF RULER DRAWING FOR THE STANDARDS
CORRELATED WITH AND ANCILLARY TO SCHOOL ARTS AND
CRAFTS

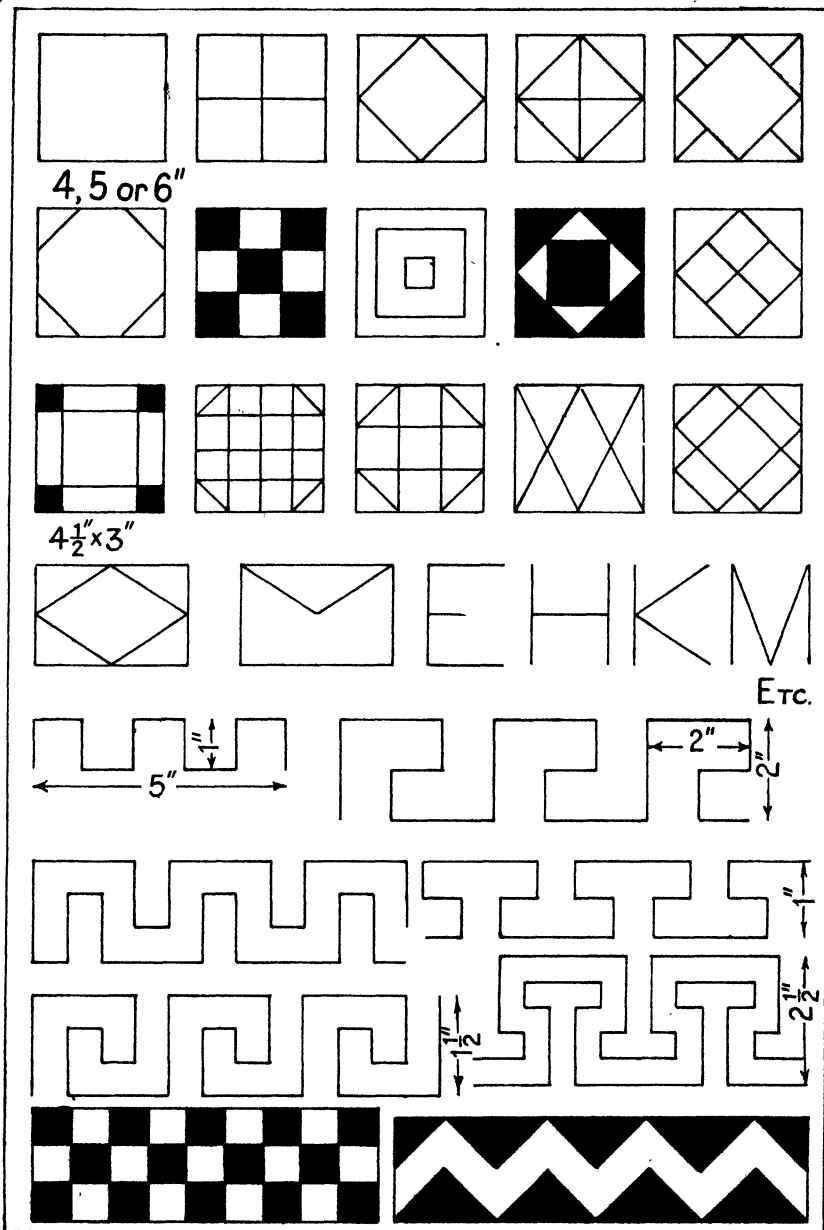

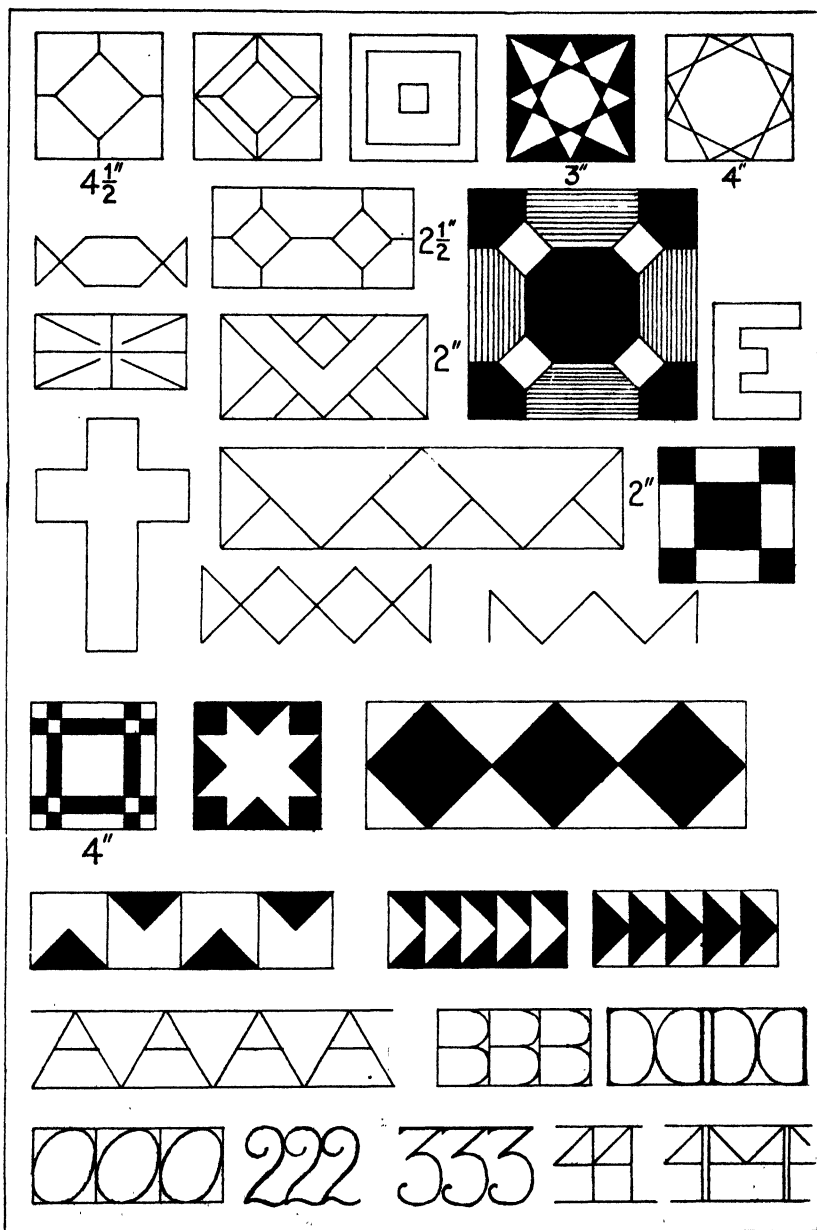

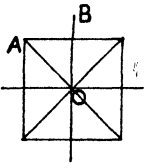

Construction based on the extensions being equal to the diagonals $BO=AO$

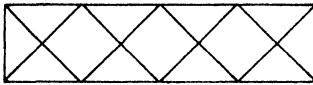
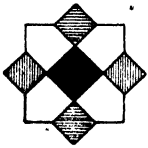
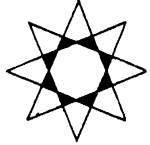
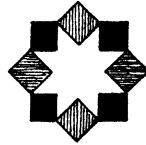
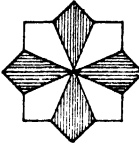
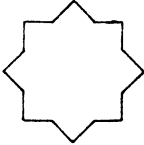
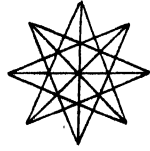
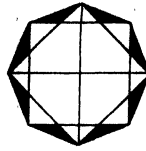
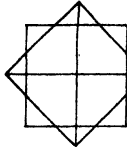

PLANNING OF OBLONGS 3" OR 4" x 1"

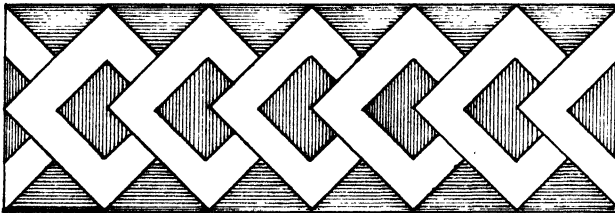
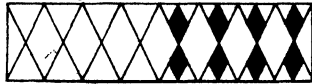
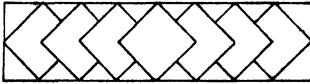

6" x 2"

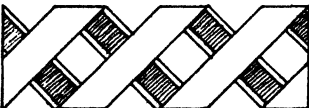
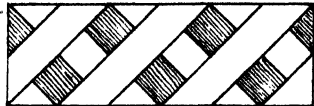
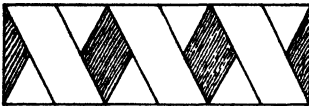

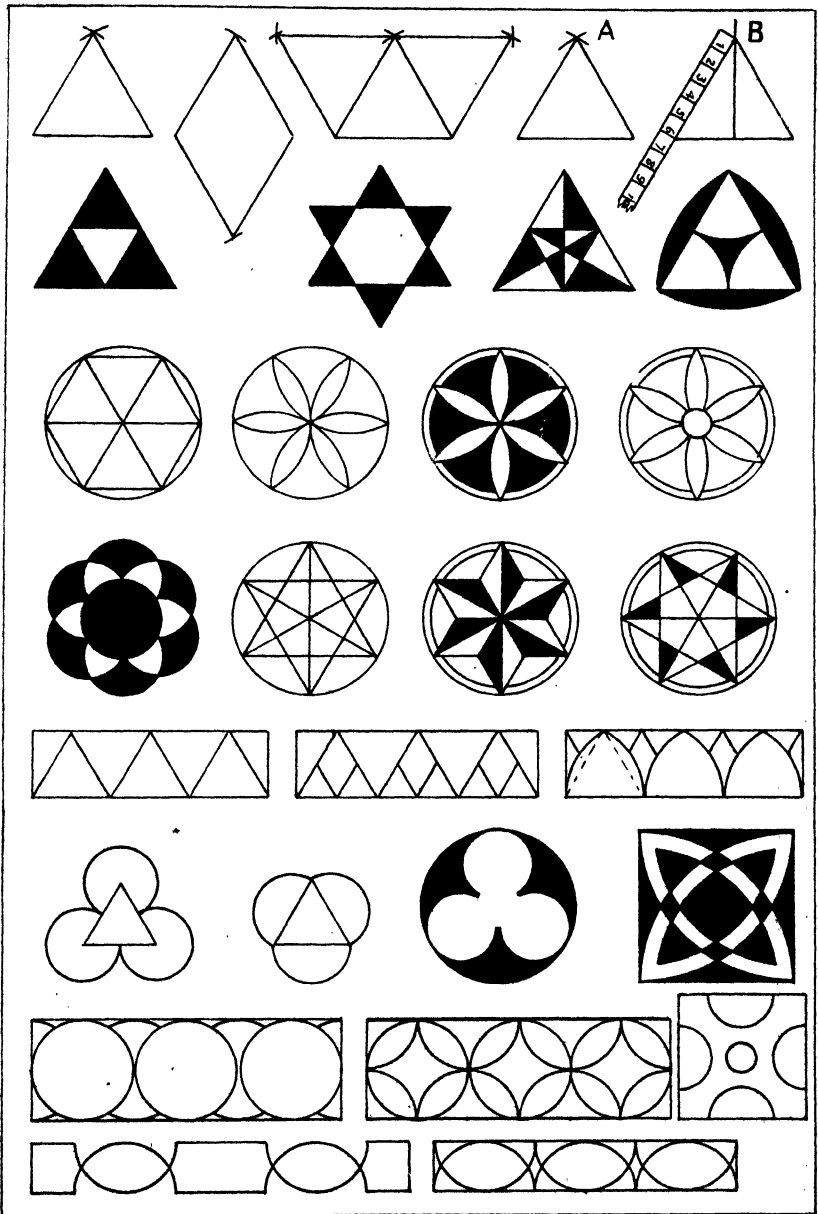

Sheet 4

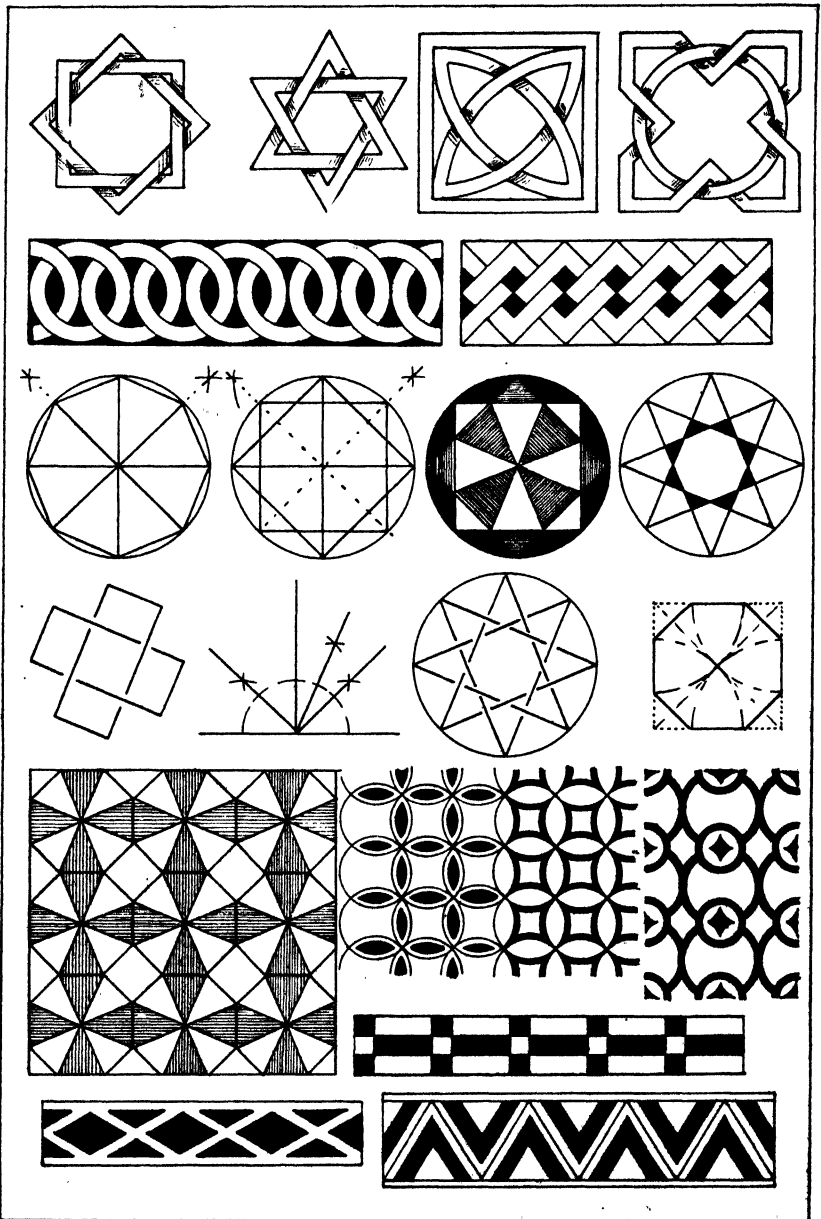

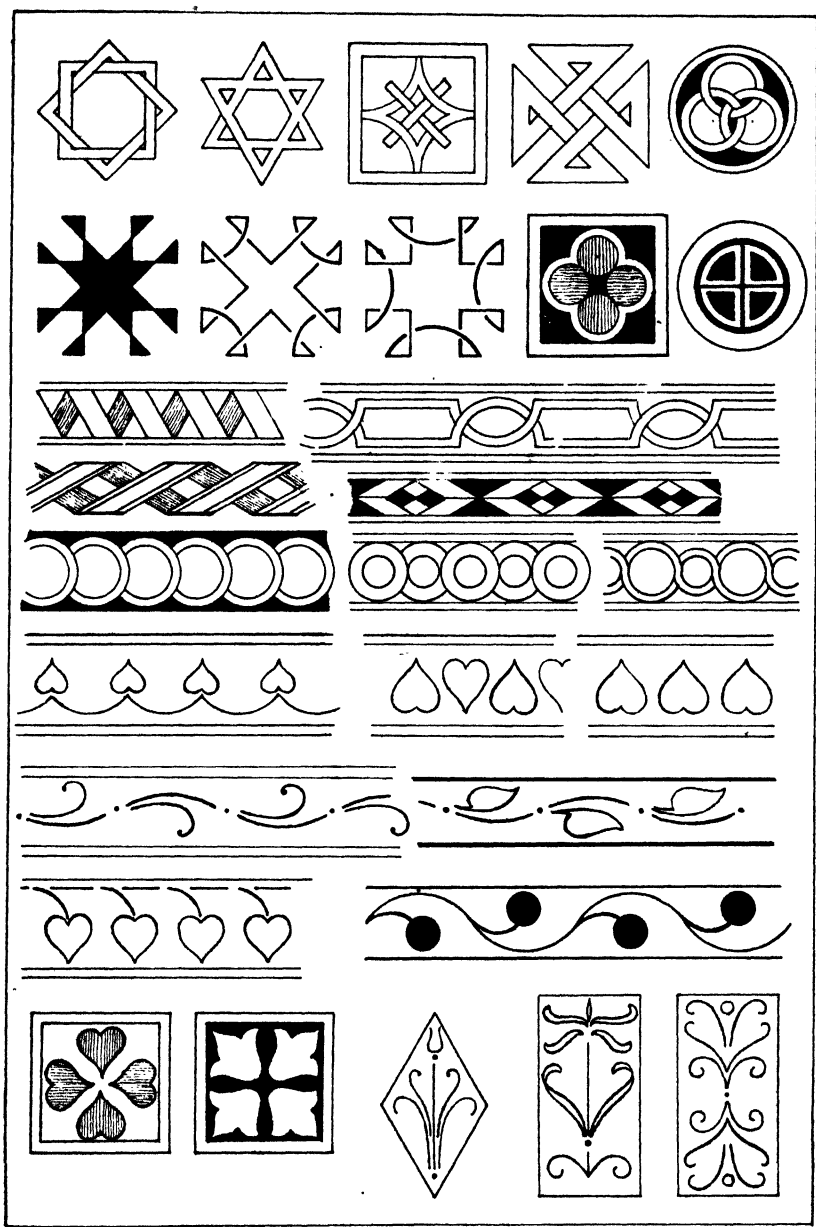

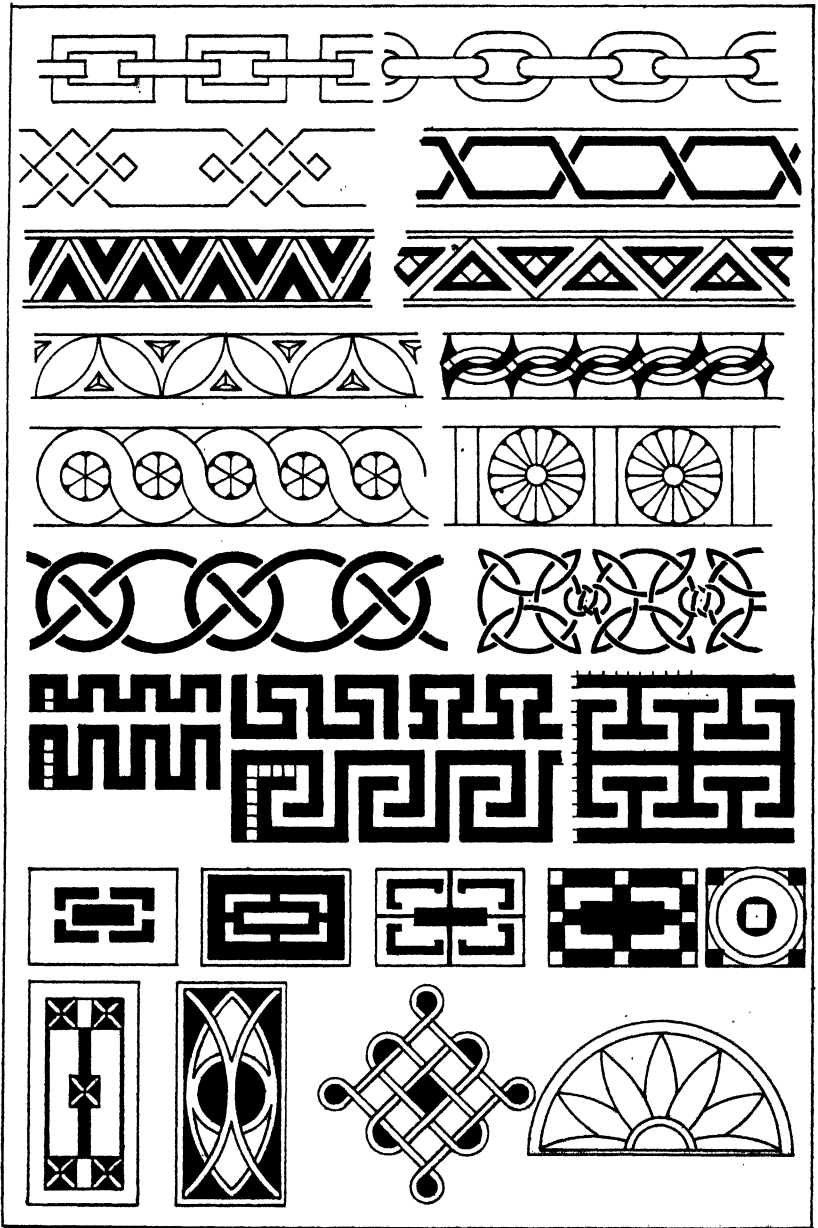

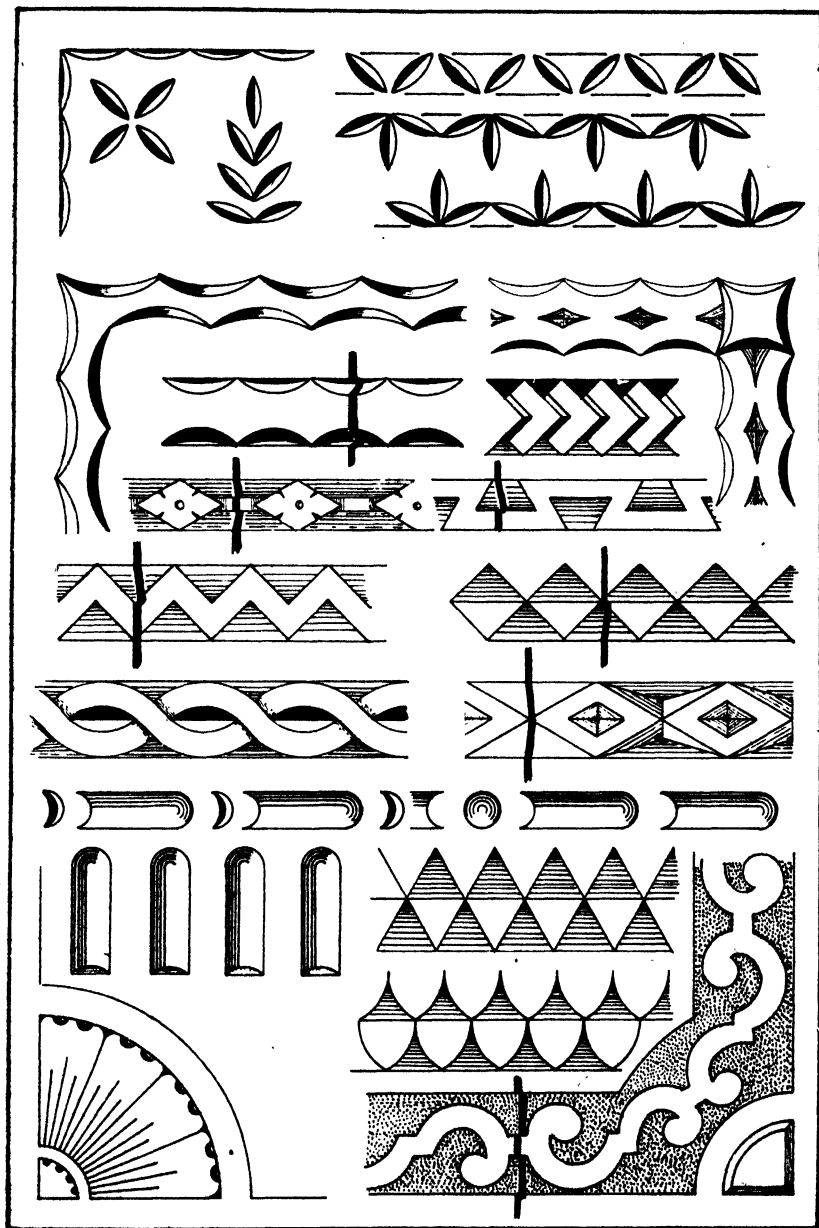

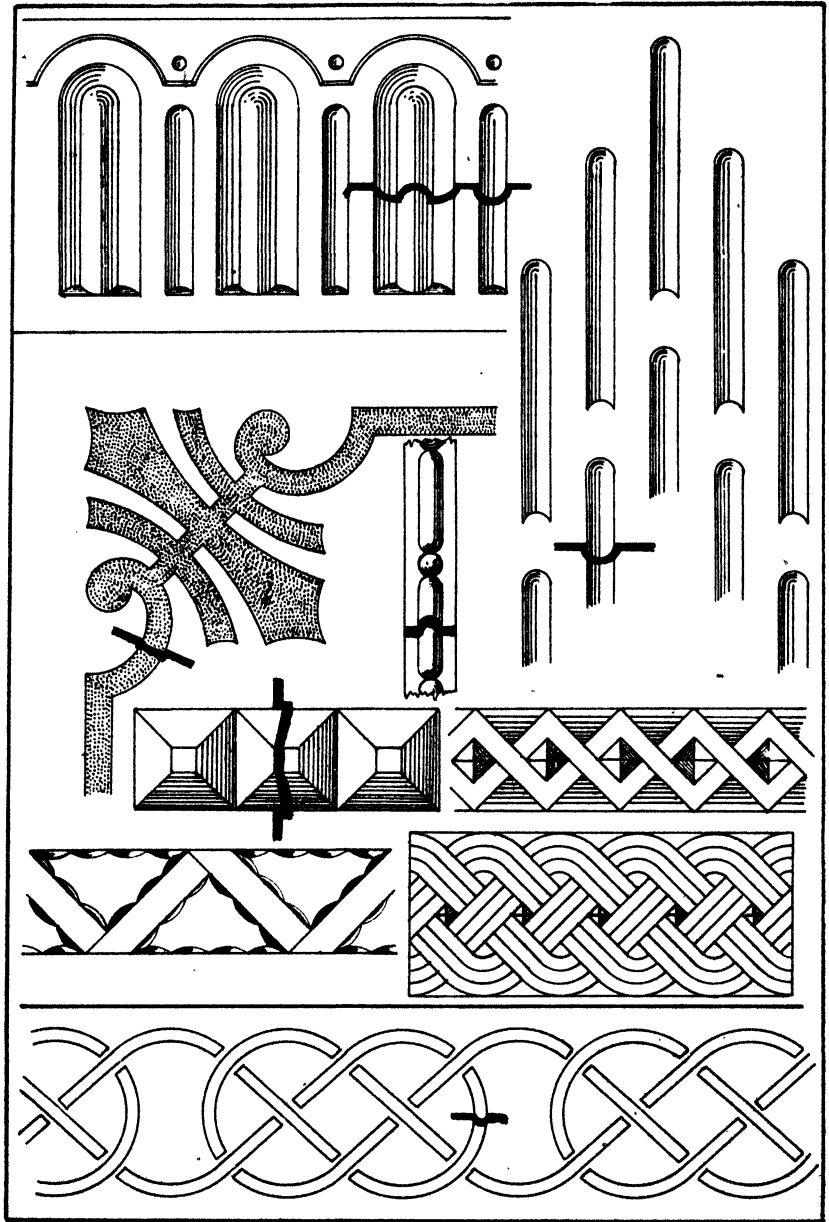



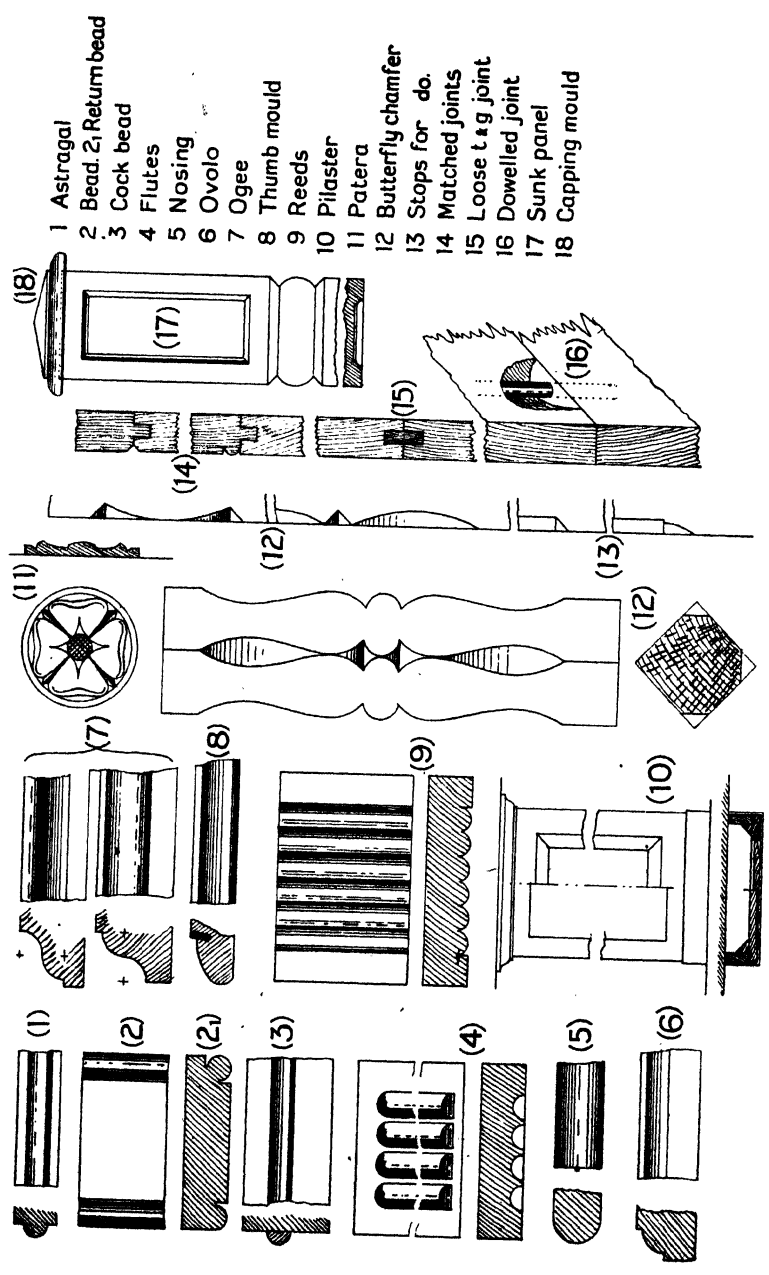

MOULDINGS, ETC.
Used in construction and decoration.

CHAPTER XIX

SIMPLE CABINET DESIGNS

Edge Shaping

ONE of the simplest ways of decorating wood is by edge-shaping. The incomplete outlines given here, all practicable for boys, are incorporated in many of the designs in this book. They can be modified for spandrels, pediments, shaped rails, legs, feet, and brackets.

The shape of an edge may be emphasized by vee-tool or veiner lines and simple carved scrolls. Some edges can be stressed by suitable echoing, or contrasting, pierced work, inlaid strings and bands, and motifs of dissimilar colour.

Chamfers, simple gouge-cuts and plain mouldings worked on the solid are other devices for enriching edges.

Care should be taken not to over-decorate any wood with a strong or interesting grain. It savours of "gilding refined gold." Styles of decoration must not be mixed, or a grotesque hotchpotch will result.

Interesting proportion is all-important, and so is variety. Long lines should be offset by short ones, curves steadied by straight lines, while degrees of curvature and slope must be laid out in a carefully considered manner.

Elliptical curves are usually more satisfying than arcs of circles. There should be few sharp exterior angles and none whatever on the edge of the grain. Unless the wood is thick, curves should be flat and must run the way of the grain.

Chamfering. This is one of the most satisfying ways of decorating an edge. It exposes a new surface and a different aspect of the grain, while, being at an angle to the rest of the structure, it adds variety and charm by increasing the play of light and shade. Chamfers have the effect of lightening, without weakening, what might otherwise be rather severe and heavy members. They may be in any form from the straight-through plain bevelled surface to a series of elaborate, dainty "butterfly" chamfers.

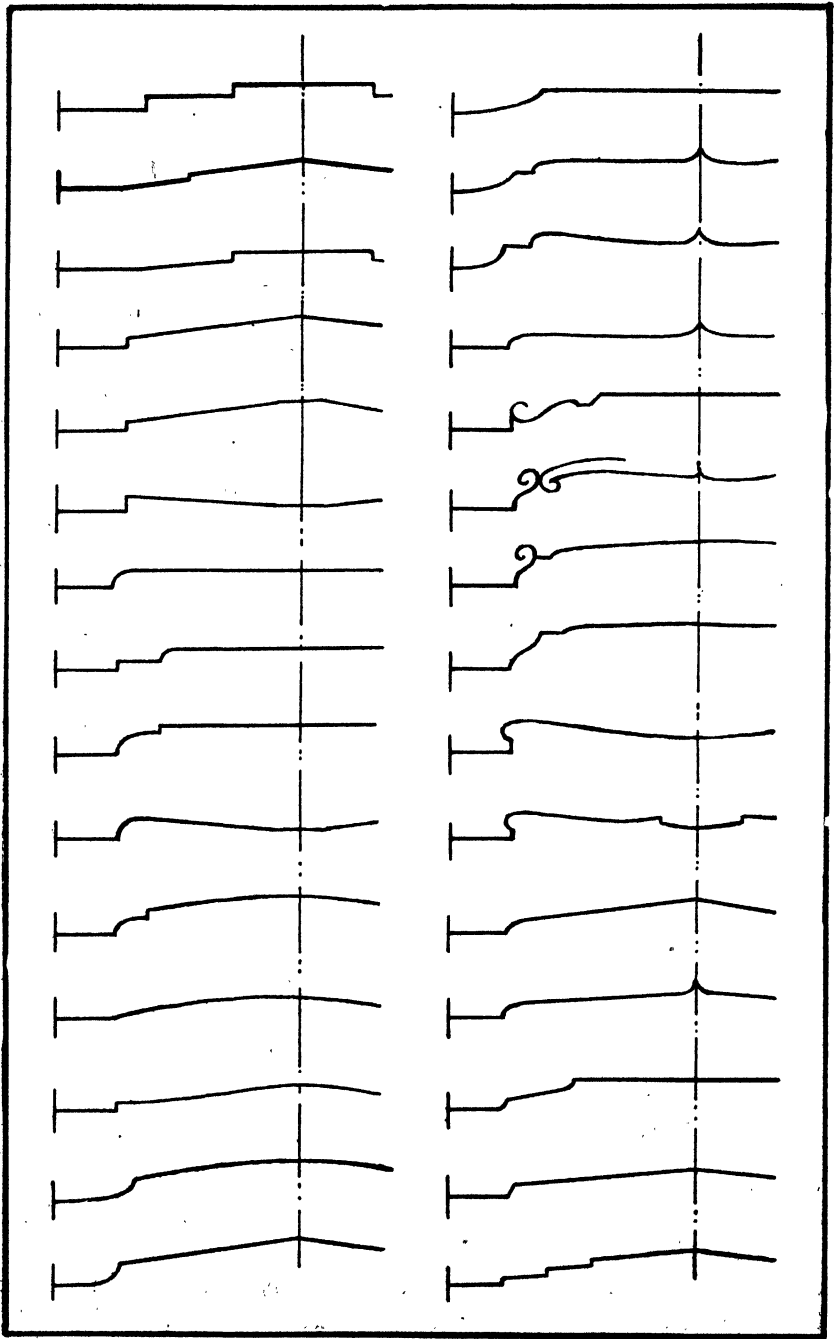

EDGE SHAPING

CHAMFERING

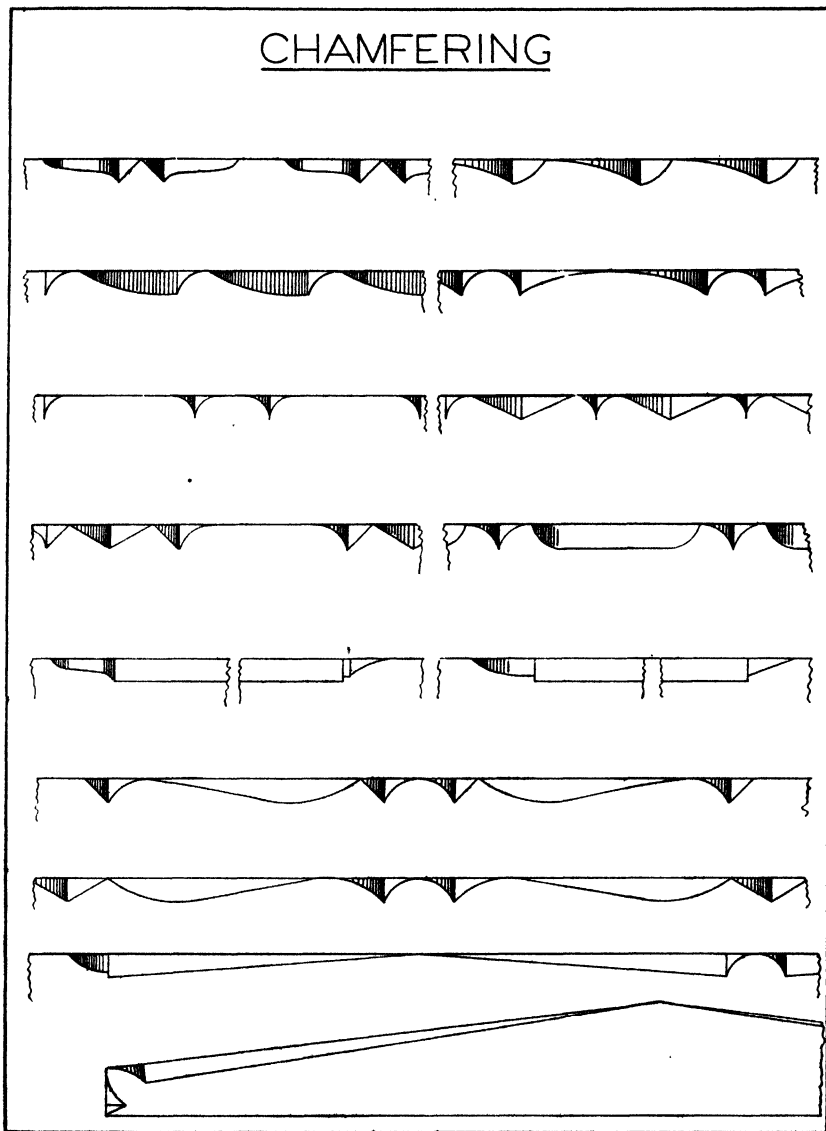

The large specimens may have to be let down with a tenon saw and chopped out with mallet and chisel or draw knife, then finished with small bull-nose, spokeshave and glasspaper. Special planes and spokeshaves are to be bought, but are largely unnecessary in school. The curved ends of a chamfer should be worked with a chisel held the reverse way and a mallet, and finished with a 6 in. cabinet file. If left to themselves, boys often glasspaper off the lovely sharp edges.

Some types of chamfer can be cut with a flattish carving gouge or firmer gouge, while the small variety can often be cut with a whittle (knife) or a pocket-knife. A small sharp iron plane is all that is necessary for making the through tapering chamfers.

Large chamfers may be enriched by simple gouge cuts or plain lightly incised carving.

Finger Plates. These are a useful medium for introducing various decorative processes and for using up odd scraps of fancy hardwoods and bandings. The illustrated examples are only types, which are capable of almost unlimited decorative variation. The average size is about 11 in. \times 3½ in.

During the making of any of the first nine examples, familiarity with common carving tools, including the punch and mallet, will be secured. The first three are carved in very low relief while No. 4 shows two methods of utilizing simple gouge cuts. The top two specimens of No. 5 can be worked with a firmer chisel, but the bottom specimen will require a gouge or two. No. 6 is a simply carved example of conventional ornament, while No. 7 could be either a stuck-on fret or a low-relief grounding out. Several kinds of chamfering are shown on No. 8.

Nos. 9 to 12 illustrate easy ways of decorating plane surfaces with plain and fancy bands of various widths and colours. Plenty of practice in using the cutting gauge, knife, chisel, and scratch stock is assured, and most of the material can be laid with the hammer pene. Plywood of good quality may be used *initially*, the top ply being pierced with the cutting gauge and removed with a narrow chisel or scratch stock.

Practice in easy veneering is given in 13 and 14. The pattern may be set out on drawing paper, dissected, and stuck lightly on the veneer which should be cut with a sharp knife or chisel and the paper torn off. The various parts should now be assembled and

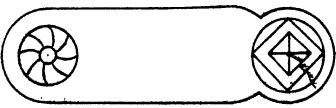

(1)

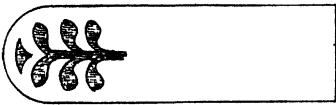

(2)

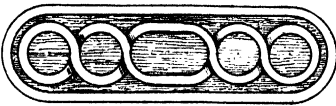

(3)

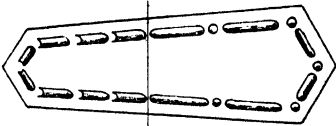

(4)

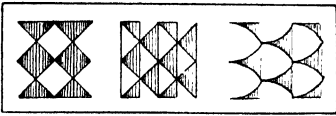

(5)

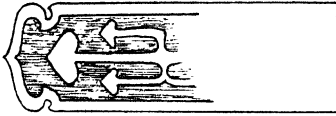

(6)

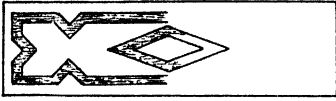

(7)

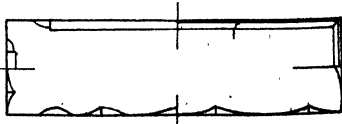

(8)

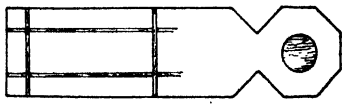

(9)

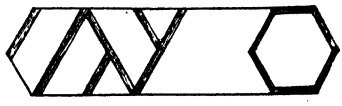

(10)

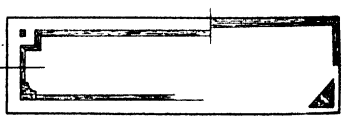

(11)

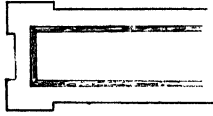

(12)

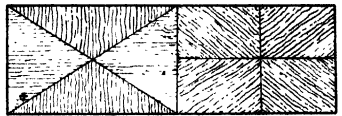

(13)

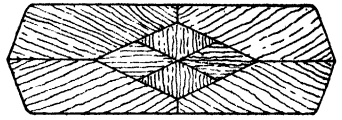

(14)

FINGER PLATES

glued on to another, thinner, sheet of paper. The upper side of the joints should be protected by narrow strips of paper glued on. When the glue is set, the paper should be torn off and the veneer glued on to the previously scratched surface of the plate.

The vice or cramps and hot cauls will usually be sufficient but the veneering hammer should be used if necessary. On such small surfaces it is rarely essential, but in some cases its use will simplify the work.

Thin wood must always be veneered on both sides to prevent curling.

Book Ends. These are type-designs only. If small quantities of rare woods can be obtained they can be used very effectively here. The joint is the double stopped housing, glued, and screwed from below. If a larger book tidy is required, the end can be lap dovetailed to the base.

1. Holly, and ebony or dyed sycamore is suggested. Only one upright is jointed to the base, the other being fastened with a touch of glue and pinned from the inside. The buttress is similarly glued and pinned. A clear polish finish is recommended.

2. Made of elm or oak. The outline is shaped with the coping saw and spokeshave, while the decoration is outlined with carving gouges and mallet. The ground which is let down about $\frac{1}{16}$ in. can be left from the chisel or punched. A suitable finish is liming and waxing.

3. This looks well in walnut. The carving is very low relief. Finish with oil and wax.

4. A very simple pattern, suitable for cherry or laburnum.

5. The fluting is done with carving gouge and mallet. The chamfers are made with chisel and mallet, and finished with fine file and glasspaper. Yew is suggested and the finish oil and wax.

6. Brown oak, limed and waxed is very effective. The carving is low relief.

7. Built up from two contrasting woods of about equal hardness. The strips may be as illustrated or may be laminae running the other way. White polish is the best finish.

If the library is a good one, most boys should experience little difficulty in designing their own book end.

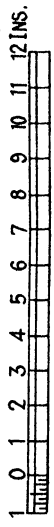
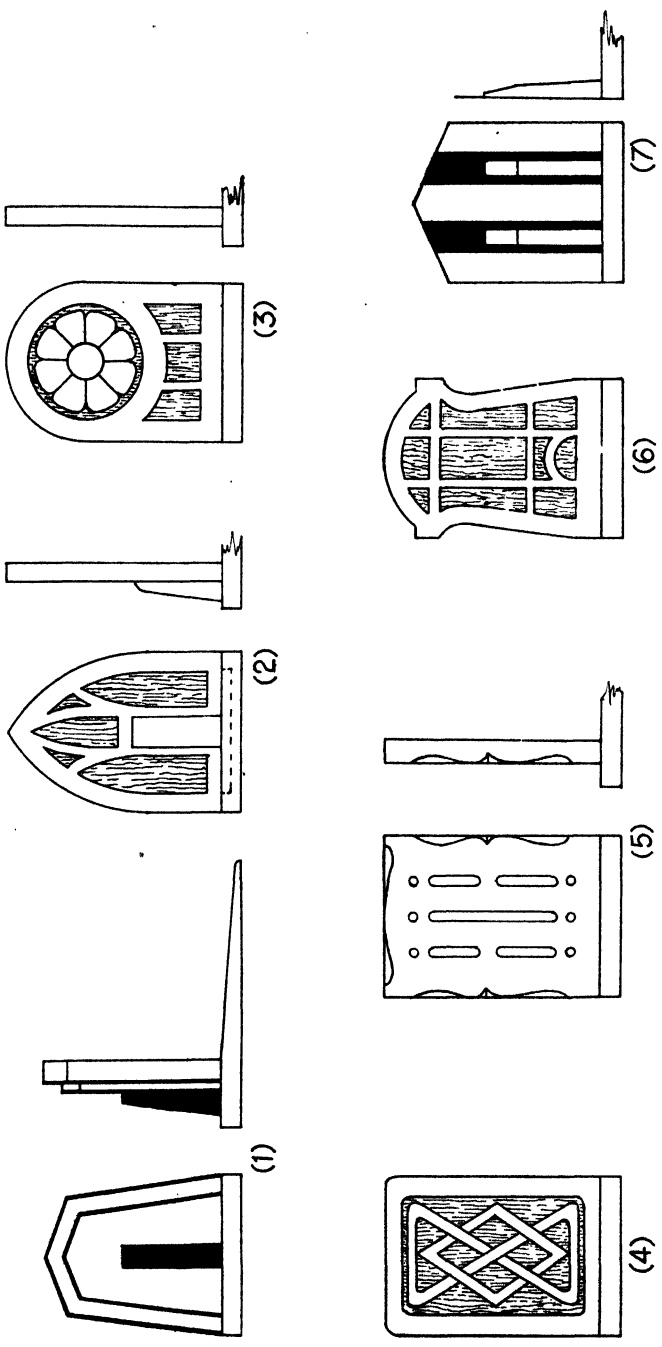

BOOK END SUGGESTIONS

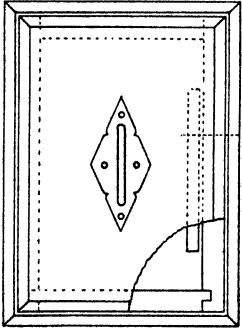
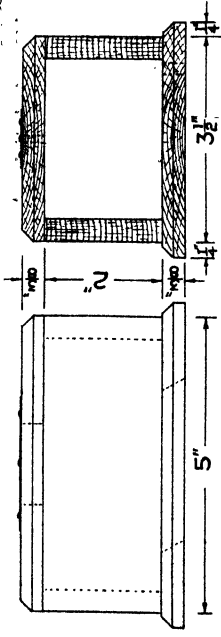

D. Money Box - Hardwood.

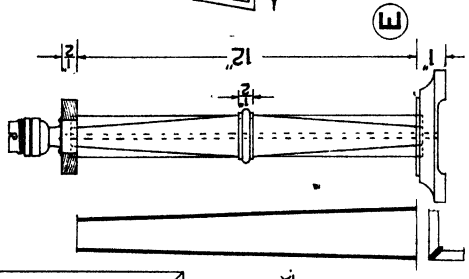

E. Table Lamp Stand - Electric - Oak.

F. Crumb Tray.

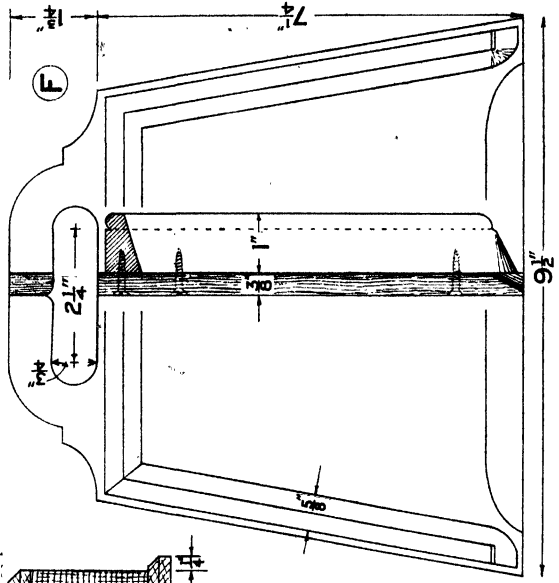

D Money Box - Hardwood

E Table Lamp Stand - Electric - Oak

F Crumb Tray

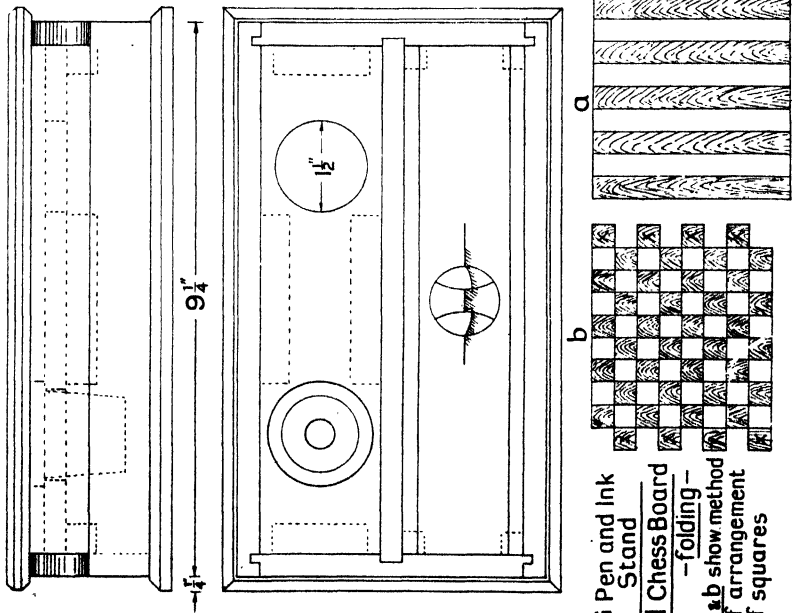
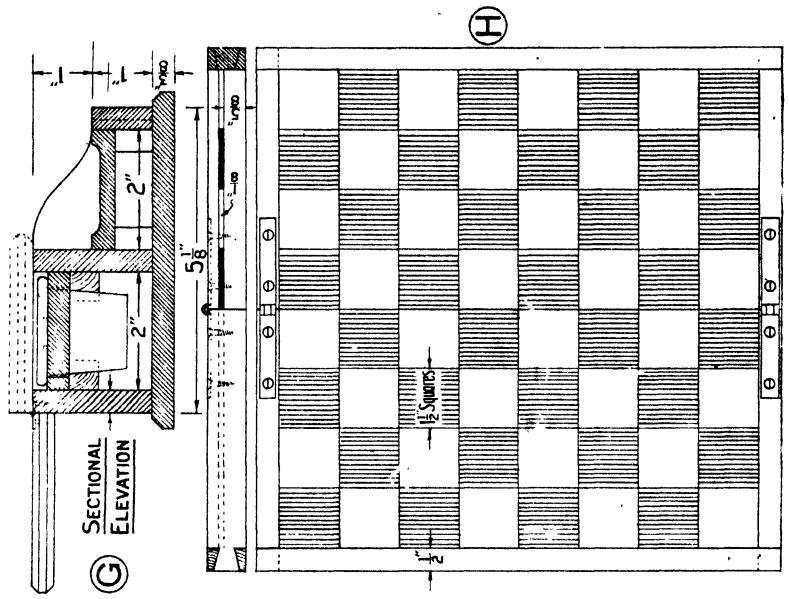

G Pen and Ink Stand

H Chess Board — folding —

a, b show method of arrangement of squares

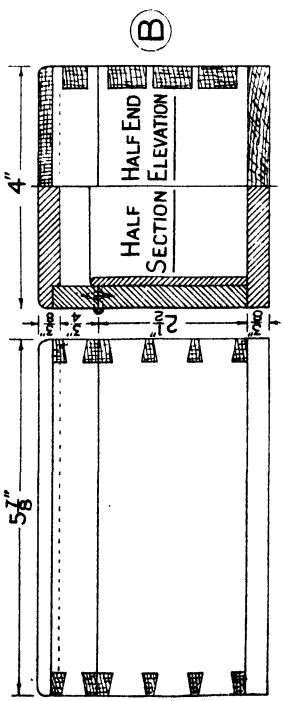
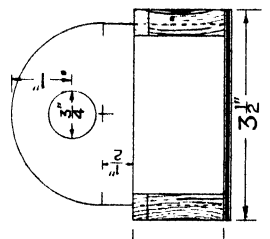
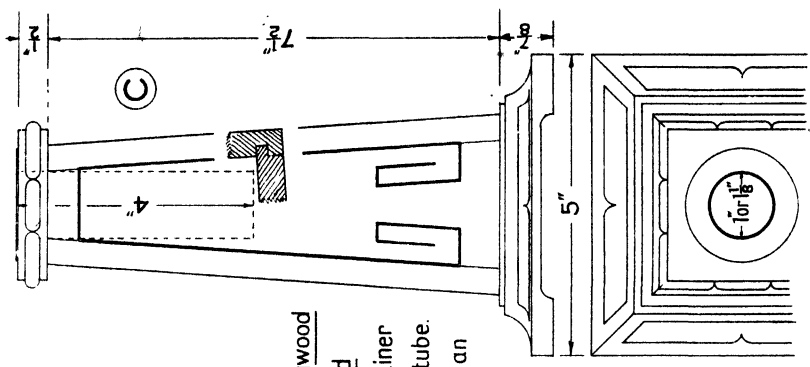

- A Nail Box - bottom of 3/8" plywood
- B Cigarette Box in Hardwood
- C Flower Stand in Oak - container
made from copper or brass tube.
Suitable for modification as an
electric light standard

Smoker's Outfit. Half inch oak is used for making this useful piece of furniture. The shaped pieces forming the back are cut from 5 mm. oak-veneered plywood. The drawer sides may be of yellow pine, canary, oak, or mahogany; the bottom and divisions of 5 mm. birch plywood.

The horizontal pieces (the rest for the pipe bowls excepted) are stop-housed into the ends. The bead on the ends and pipe shelf

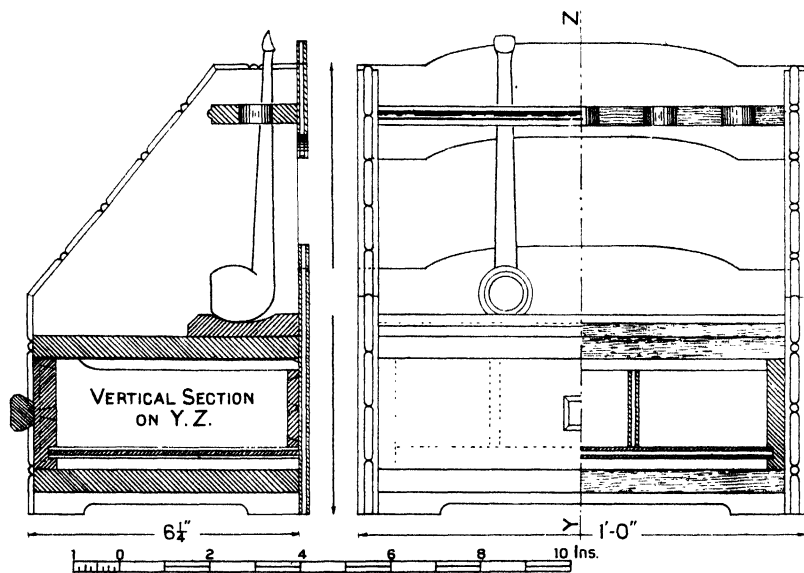

SMOKER'S OUTFIT IN OAK

are stuck with $\frac{1}{2}$ in. astragal bead plane, the pearl and bead being formed with a $\frac{1}{4}$ in. carving gouge. If desired a $\frac{1}{8}$ in. white stringing or banding could be substituted for the bead and carried along the drawer front $\frac{1}{2}$ in. from each edge. The divisions in the drawer provide two compartments for cigarettes—the cigarettes parallel to the drawer front—and one compartment for cigars parallel with the drawer sides.

Construction. Prepare, fit, and fix the "carcase" together. Prepare and fit the drawer front, sides and back, care being taken to allow for the "lap" on the drawer front. Make the back $\frac{5}{8}$ in. narrower than the drawer front, groove the front and sides with a $\frac{9}{16}$ in. plough bit. Set the cutting gauge to thickness of drawer sides and

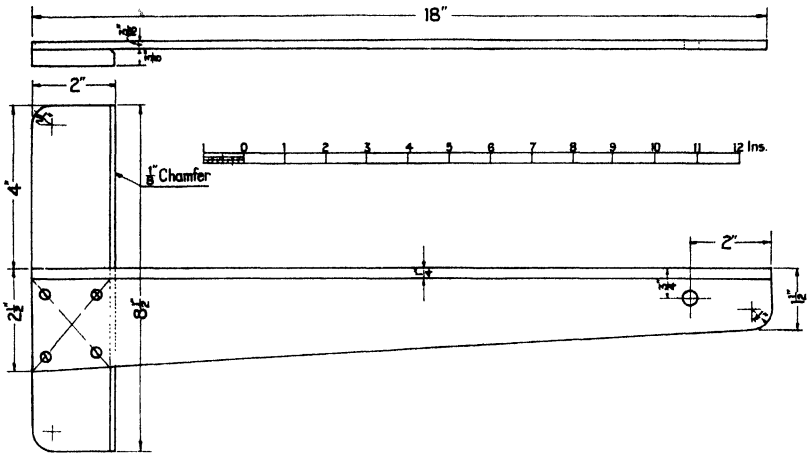

TEE SQUARE

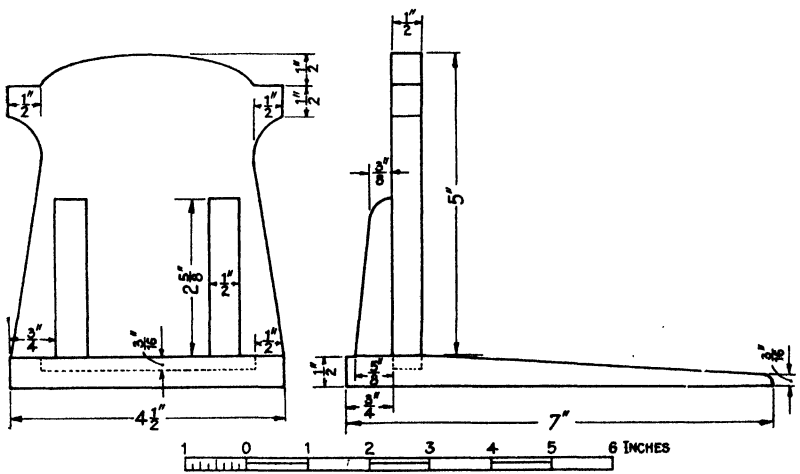

BOOK END

gauge on both sides of drawer back, and inside only of drawer front. Set gauge to thickness of drawer back and gauge the back end of drawer sides on both sides. Re-set gauge to $\frac{3}{8}$ in. and gauge on both ends of drawer front, and both sides and edges of front end of drawer sides. Set out and work pins on drawer front and back, and from these mark the dovetails on the respective ends of the drawer sides with the scribe. Saw and chisel out sockets for the

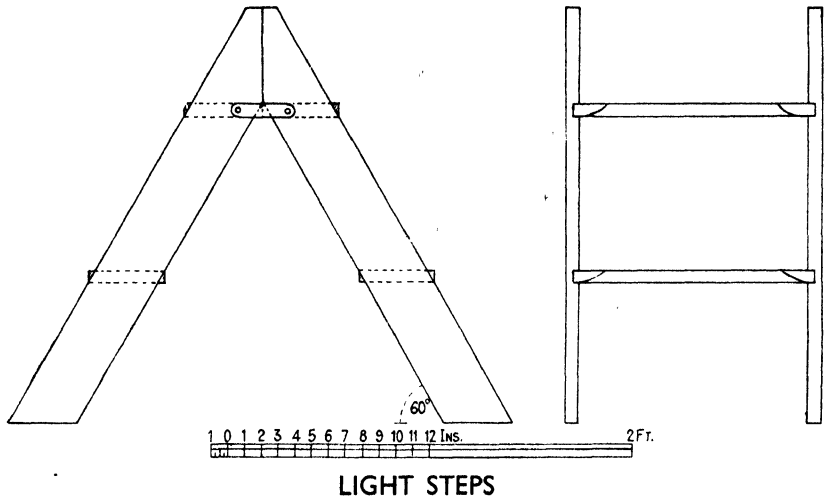

LIGHT STEPS

pins. Set out and work vee grooves for divisions in front and back. Clean up inside of drawer, glue, and knock together—test for being square—fit and fix drawer bottom with two oval nails in edge of drawer back. Clean off sides of drawer and fit into place.

The pipe rest is worked with a fairly flat carving gouge and finished with glasspaper. The pipe rest is fitted tightly between the ends and glued to the shelf.

A small drop handle, or one made of oak, which could be glued and screwed from the inside, may be used for the drawer.

Light Steps. The usual household steps are often too heavy and cumbersome for a woman to carry easily about the house. Those illustrated, though quite light, are strong and rigid. The top treads form a platform $13\frac{1}{2}$ in. \times 9 in. which is 2 ft. from the ground. This is high enough for most household high dusting, curtain hanging, etc.

The treads are housed, glued and skew-nailed into the uprights.

The hinges shown are metal strips 4 in. \times $\frac{3}{4}$ in. \times $\frac{1}{16}$ in., screwed into position with $1\frac{1}{2}$ in. round-headed screws. Special hinges can be bought for the purpose, but the strips shown are quite satisfactory.

Sink Tidy. The two long back rails are lapped and screwed to the uprights and the three $8\frac{1}{2}$ in. \times $\frac{3}{4}$ in. \times $\frac{1}{4}$ in. slats are fastened with round-headed brass nails or shoe rivets.

The hinged tray arms pivot on $\frac{7}{8}$ in. brass screws. The tray slats are fastened with $\frac{5}{8}$ in. brass screws from underneath.

When in use, the tidy hangs against the back of the sink, standing off 1 in. at the bottom. By this arrangement the droppings fall into the sink and do not trickle down the wall, while the tray is tilted backwards so that things do not fall off.

Elm or oak is suggested.

Electric Reading Lamp. The material should match the furniture of the room it is to occupy, while the decoration will depend upon the wood chosen. It can be made of mahogany and inlaid with contrasting lines in panels or running round the post parallel to the base, spirally or zig-zag. The standard can be of any geometrical shape enriched by gouge cuts, flutes, chamfers or very low relief carving. The base shape will depend upon the section of the standard, or *vice versa*. If the standard and base are each built up of contrasting woods a very pleasing effect can be obtained.

The standard should first be squared and bored from both ends. The square tenon on the lower end is now made and the taper and decoration added.

The $\frac{3}{8}$ in. collar should now be made and slipped on to the tenon. Now plane up the base, mortise it, and add the bevels.

Glue the standard into the base with the collar between. The tenon should be wedged diagonally and the portion of the wedge crossing the hold bored out.

The feet are made in one length, sawn off, pinned and glued to the underside of the base. Baize should be glued to the feet to prevent scratching.

The stand will take standard table lamp fittings, but a brass tube with an interior diameter equal to the exterior diameter of the fitting may have to be driven or screwed into the hole at the top, and the fitting knocked tightly into or sweated into it before driving into the hole.

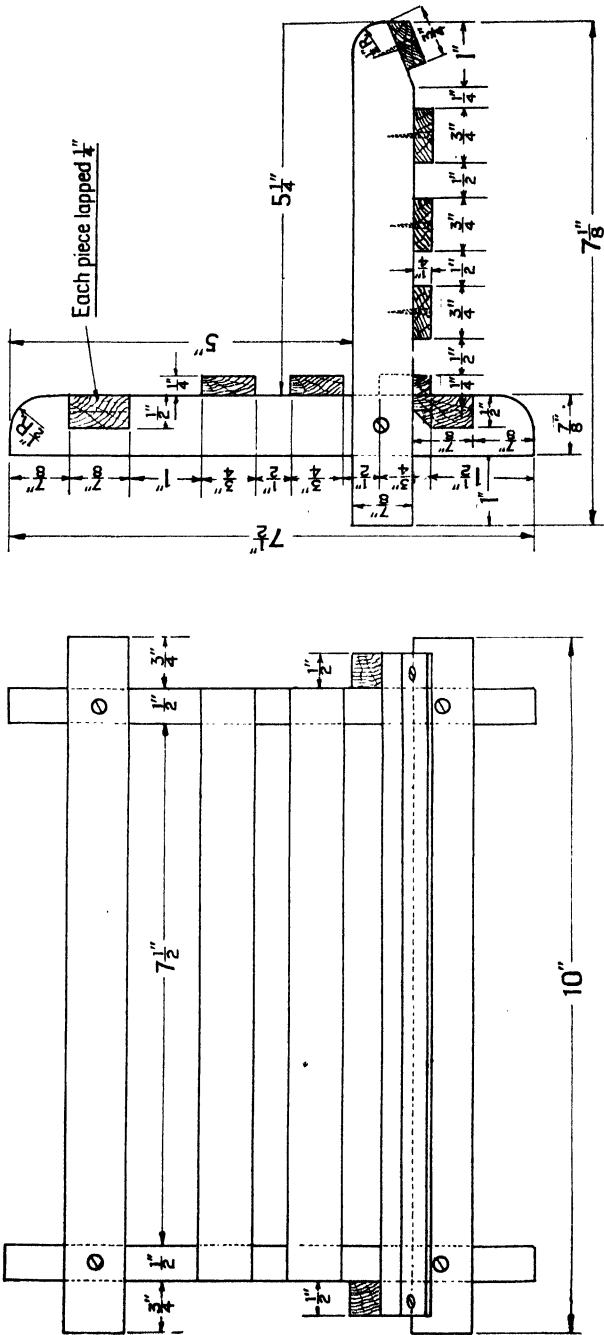
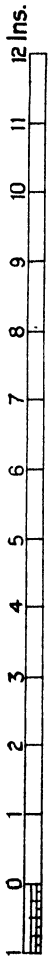

The flex can be arranged to leave the standard through a hole bored at right angles into the lower end of the shaft. This is really unnecessary as the base stands well off the table, but an insulated

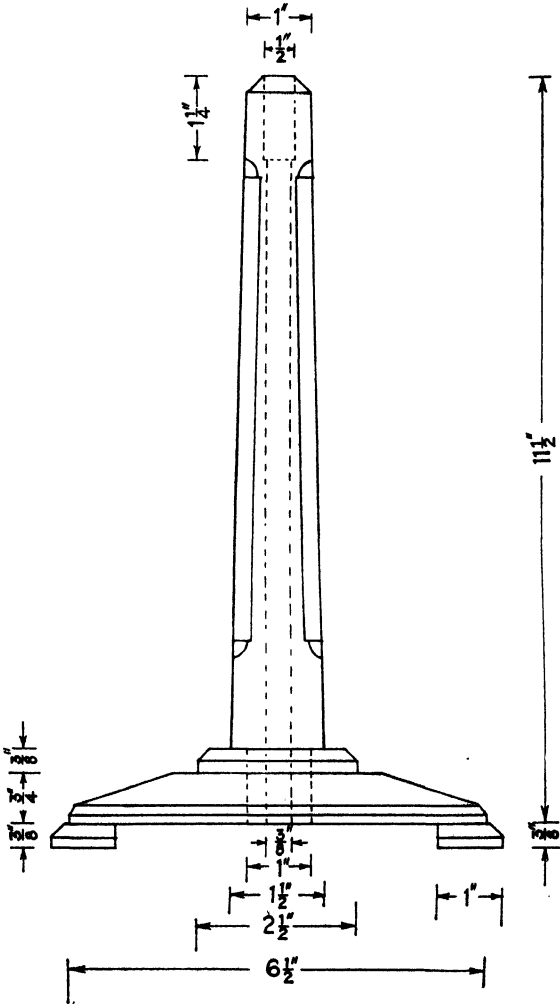

TABLE LAMP STANDARD

staple should be driven into the underside of the base to pin the flex so that it cannot be dragged out of the fitting.

Clothes Airer. Only one wing is shown. The rails are bareface tenoned into the stiles, fitted dry, draw-bored, and pegged.

The small pivoting rails are for small articles. The short horizontal members are dry tenoned and pegged into the stiles, while the rails swing on a $\frac{3}{8}$ in. dowel rod.

The wings of the airer are hinged together by webbing fastened with copper nails, which will not iron-mould the damp linen.

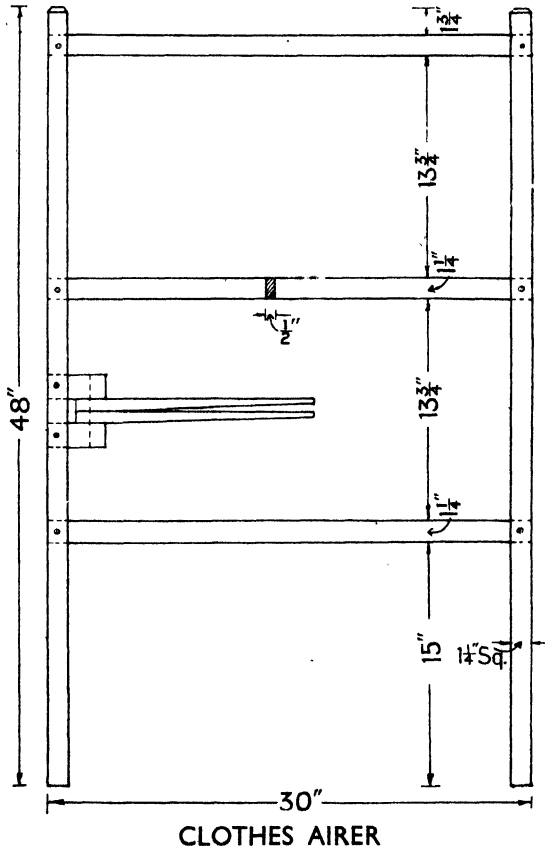

Small Stand. The sizes of this article are: Height 2 ft., trays $8\frac{1}{2}$ in. \times $8\frac{1}{2}$ in. \times $\frac{1}{2}$ in. and $11\frac{1}{2}$ in. \times $11\frac{1}{2}$ in. \times $\frac{5}{8}$ in. These are inside diameters. The rim is worked with a $\frac{1}{8}$ in. bead plane and projects $\frac{1}{8}$ in. above the top surface of the trays.

The pillar tapers from the surface of the lower tray to 1 in. at the top. The corners may be relieved by stopped chamfers, butterfly chamfers, or other means.

The brackets are first cross halved together, the top set being let into the top of the pillar solid as shown in the drawing. The lower brackets are also cross halved, but in this case the bracket with the

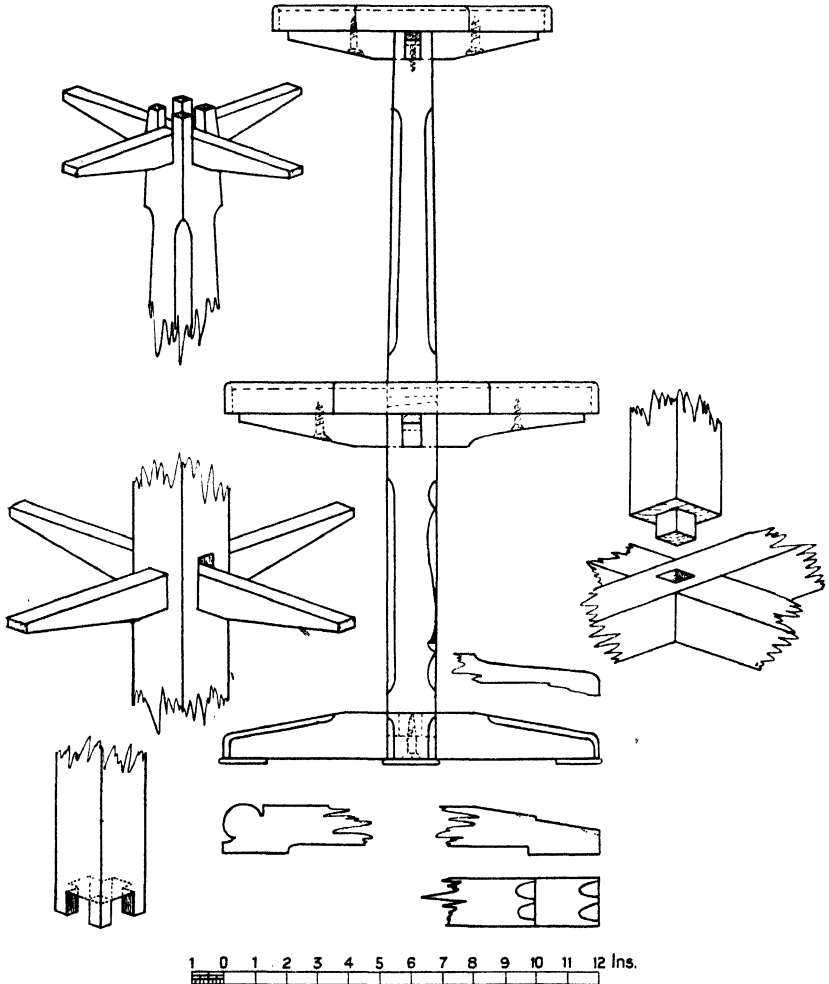

notch in the upper half is mortised tightly through the middle of the post. The other bracket is also fitted tightly into a mortise at right angles and in alignment with the first, but half the width of the bracket deeper. The extra should be taken out of the top end

of the mortise. This will allow the second bracket to pass through and over the notch in the first bracket, which can then be knocked into place. The brackets are finally fixed with folding wedges which are hidden and secured by the tray.

The base is halved together and the pillar fitted into it by means of a $\frac{3}{8}$ in. square finger at each corner fitting tightly into the top half of the lap joint. If a successful fit is made, glue will be sufficient to hold it. When set, the other part of the stand can be glued and screwed. An alternative method of fastening the pillar is shown, but is not considered as efficient, though simpler to make.

Solid trays of any shape may be introduced and dished, in place of the planted bead rim construction.

The base should not project beyond the lower tray or it will be kicked.

The top tray will take a 9 in. or 10 in. plate and the lower one is large enough to hold four cups and saucers. If the stand is darkened, the colour on the chamfers and middle of the trays can be rubbed to a lighter shade.

Book Trough (after Peter Waals). The original design has been modified to make it suitable for making by schoolboys and is an example of how designs have to be simplified for school use.

For setting out a templet is essential. If the width of the back is reduced by $\frac{3}{4}$ in. at its lower edge and the shelf reduced $\frac{3}{8}$ in. at the back, there will be no corner to harbour dust.

The tenons may project $\frac{1}{8}$ in. and be chamfered. The grain of the ends should run vertically.

Foot Rest and Shoe Brush Box. Sturdiness is the characteristic of this article which is designed to stand rough usage. It should be made of deal, canary or satin-walnut.

The legs being $1\frac{1}{2}$ in. square will take a strong $\frac{3}{8}$ in. thick haunched barefaced tenon. If this tenon is fitted with the shoulder to the front the rail will be flush with the face of the leg. If fitted with the shoulder inside, the rail will stand back and allow the nosed bottom to project a little. The bottom should be nailed on or pinned into a rebate previously worked on the inside of the under edge of the rail.

The top is hinged as shown so that it will fold right back. The fixed portion is screwed, nailed or glue-blocked into position.

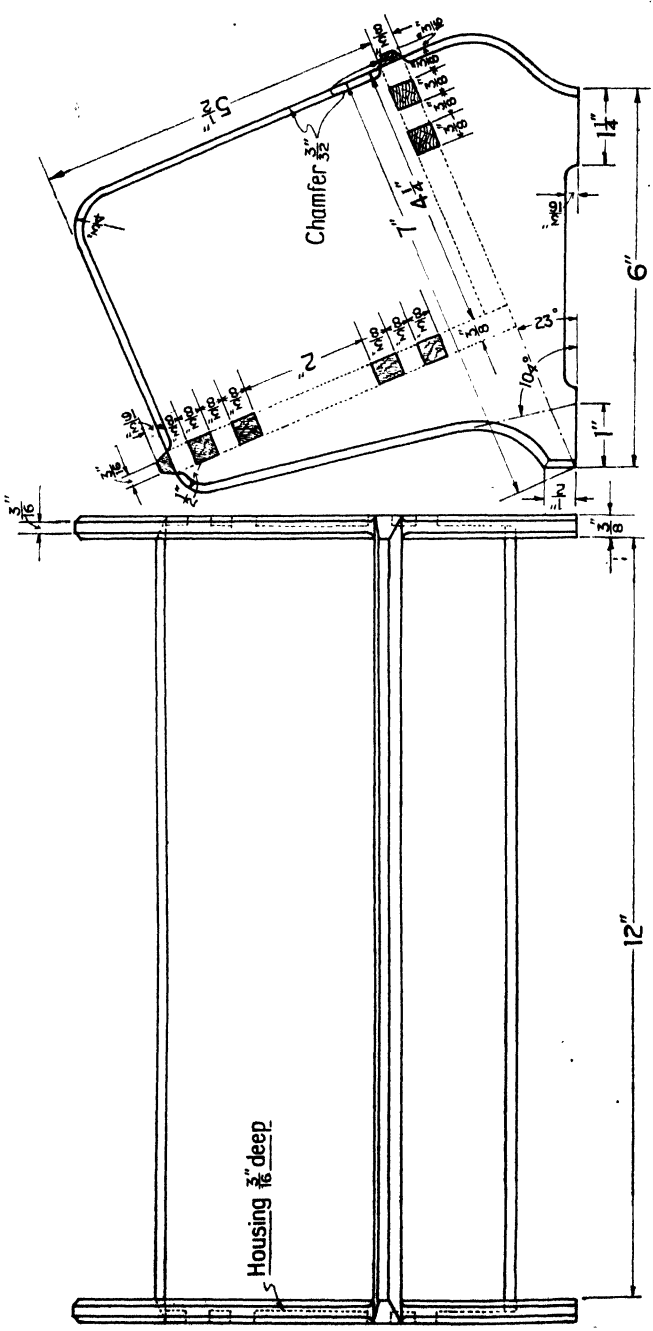
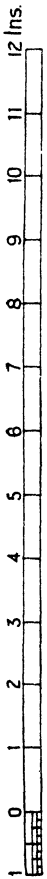

BOOK TROUGH

A cellulose finish is suggested as it is both durable and washable. No decoration is required.

Skeleton Bookshelves. Two framed ends are joined together by lap dovetailed $1\frac{3}{4}$ in. \times $\frac{3}{8}$ in. section slats (B), and housed shelves.

The rails, $\frac{1}{2}$ in. thick, of the end frames are stump tenoned into the stiles, the tenons being barefaced and flush with the inside of the

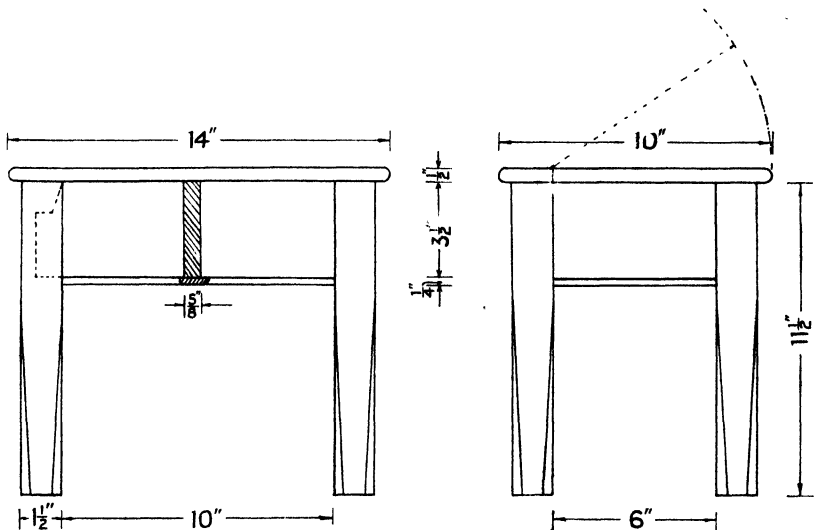

SHOE BRUSH BOX

end frames. Alternative treatments of the front frame posts are shown.

In gluing up the end frames, care must be taken that they are square and out of wind. When the glue is quite set, the stop housings for the shelves should be worked in the usual way. If the housings are allowed to come through to the front as at *A*, the shelves can with advantage project some $\frac{3}{8}$ in. and be sharply bevelled down to meet the front edge of the frame. If the front edges of the shelves are chamfered as shown, the effect, though uncommon, is satisfying. The rails may previously have been ploughed in one long length to take the shelf ends. This leaves very little housing to do when the frames are assembled.

The end frames may alternatively be framed with panels in

the middle two bays, and a stepped and chamfered spandrel can be added. There will still be room to sweep or dust underneath.

Mortised or/and bridled feet can be added as shown by the broken line.

Oak Fitment. The ends and door are framed together using $\frac{5}{8}$ in. or $\frac{3}{4}$ in. finished stuff and 5 m.m. veneered plywood for the panels.

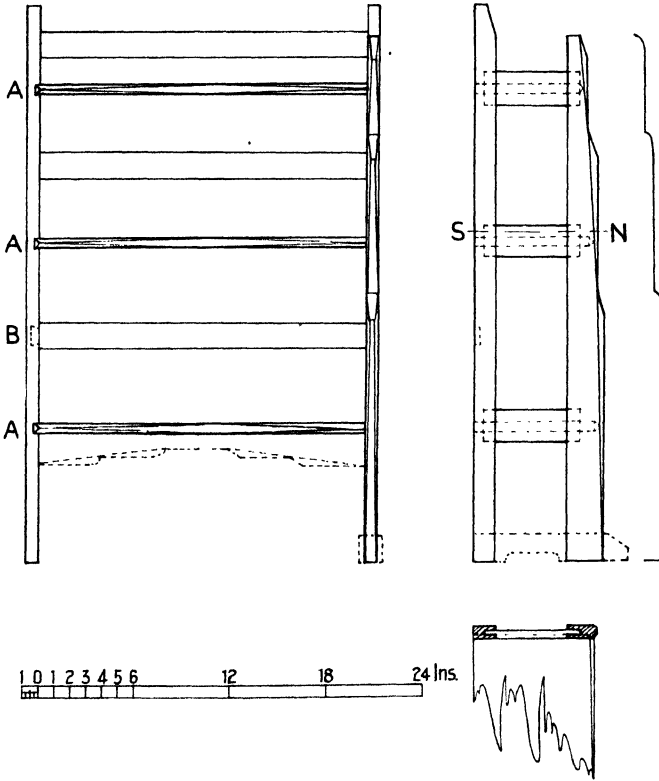

SKELETON BOOKSHELVES

The edges may be stop-chamfered, left square or otherwise suitably modified.

Front and back stretcher rails are lap dovetailed into ends—shelf stub tenoned—and bottom fitted into stopped groove with a rebated tongue. The groove in the bottom rails should be worked before the frames are glued together. The back stiles are rebated to take the back. If the base is fitted as shown in sketch any risk

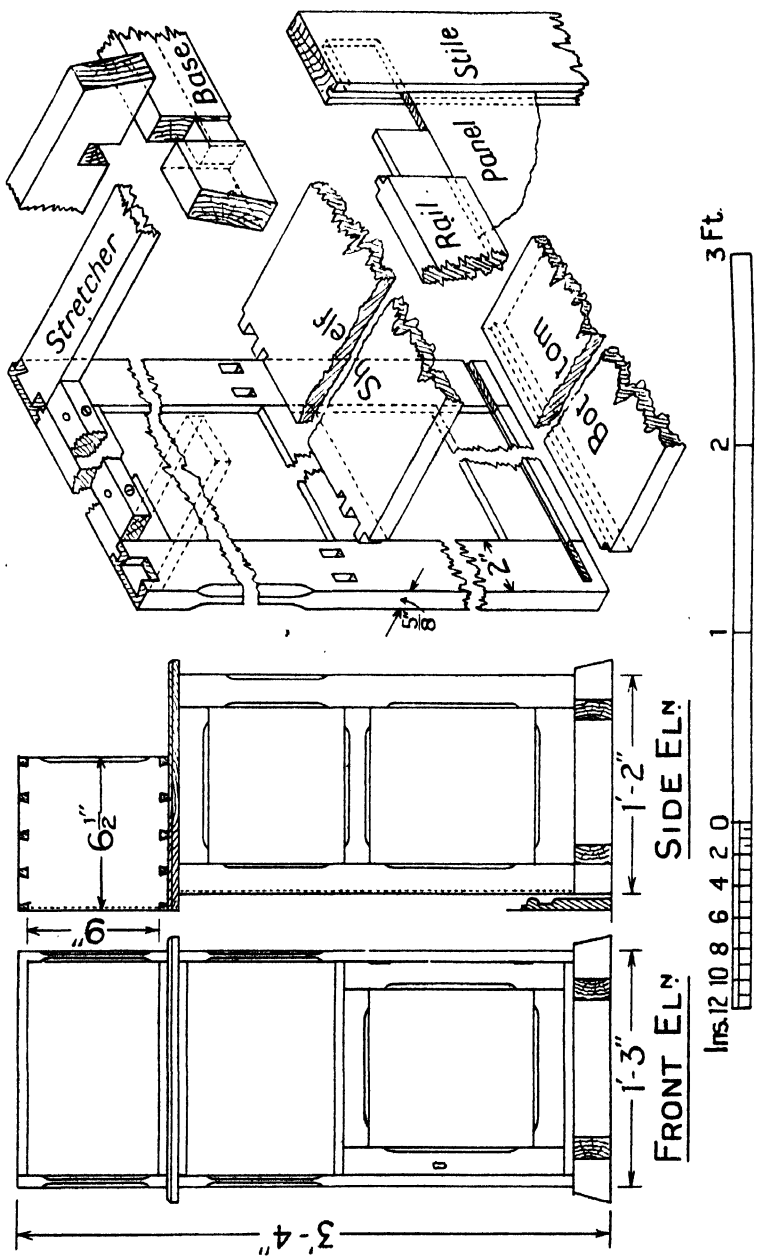

OAK FITMENT
 3 ft. 4 in. high, 1 ft. 3 in. wide and 1 ft. 2 in. deep.

of fracture due to occasional knocks or kicks will be obviated. The pins and dovetails of the box must be well made to give a workmanlike finish.

Table Loom. The two-heald loom shown here is a real working machine, not a toy. It is suitable for plain or striped tabby weaving and can easily be fitted with treadles if desired.

The elevation shows one side, one end, one beam post, one heald post and the moving part to hold the reed.

The frame is dry dovetailed and fastened together with a long screw in each joint. It can thus be dismantled and packed away



BOYS' WORK

when not required. The four beam posts are alike. They are shouldered $\frac{1}{4}$ in. and screwed to the frame from the inside. The ratchets and pawls may be of hardwood, but are more efficient if made of metal. The ratchets are drilled, countersunk and screwed to the ends of the beams. Two of each are needed. The beams may be octagonal in section and are ploughed to take a lath.

The tops of the heald posts are slotted to take the ends of the heald roller and bored at the bottom ends to take two dowel rods.

The heald frames are two light metal frames moving up and down in the grooves ploughed in the roller posts. Two holes are drilled in the top bars of these frames and two more are drilled in the bottom bars exactly opposite them.

All these holes should be opposite to the pegs in the heald roller

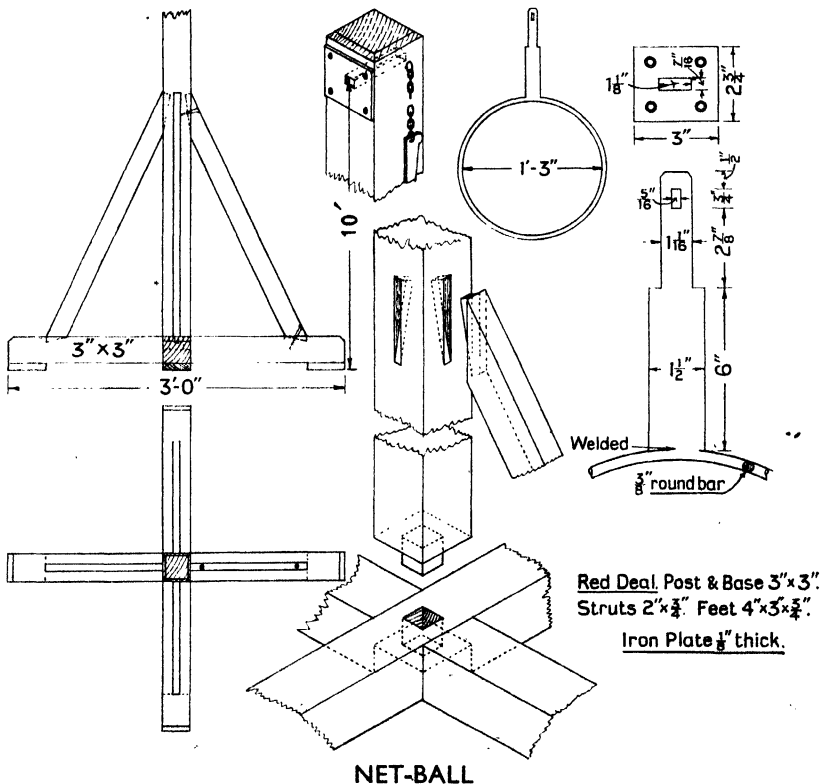
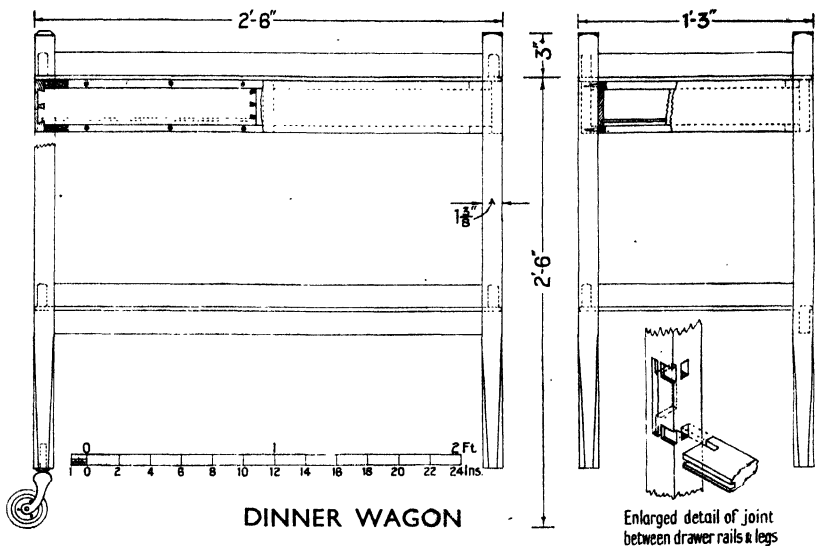

which act as handles for making the shed in the warp. The tops of the frames are corded to these handles and the bottoms corded together, the cord passing under the two lower dowel rods. Rigged as suggested, the frames are subjected only to a straight vertical pull and work quite smoothly.

If wooden heald frames are required, the vertical grooves in the heald posts should only be $\frac{1}{8}$ in. wide and should be fitted with

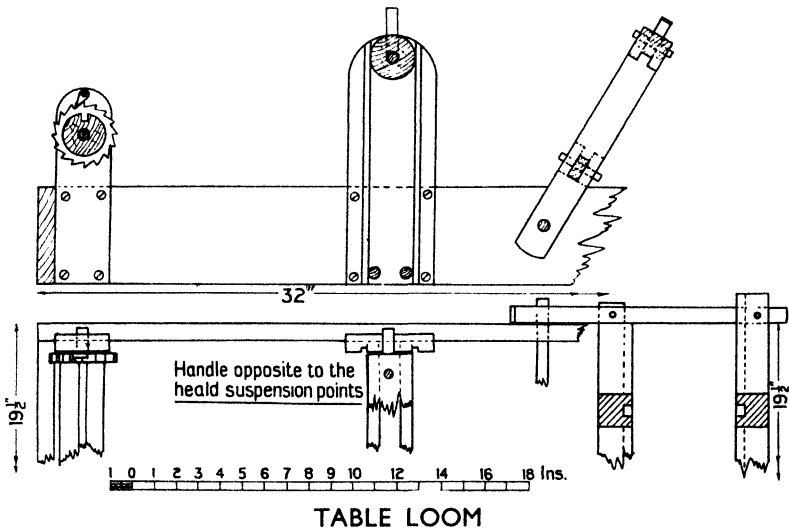

slips of hardwood—sycamore—about $\frac{3}{4}$ in. wide. These must be glued in position under pressure. The wooden heald frames will slide on the outside of these guides. If long healds are used, all the posts must be two to three inches taller. Nothing else need be altered.

The "moving part," i.e. the heald frame or sley, must be made of hard, heavy wood. The joints must be a tight sliding fit, put together dry and pegged so that the reed can easily be changed. The top and bottom rails are grooved to the reed.

All the spindles are birch dowel rods.

Bureau in Oak. This is a suggestion for a design which could be made either by hand or machinery, and is very suitable for modification. The cupboard door and drawer fronts could be made from veneered multi-ply or laminated wood, their ends and edges being

covered with oak veneer. The carcass ends and top could be made of $\frac{3}{4}$ in. (finish) solid stuff, and the bottoms, rails, and stretchers of canary or pine "faced" with a $\frac{1}{2}$ in. or $\frac{3}{4}$ in. oak strip. The drawer rails may be stub-tenoned or dovetail-housed into the ends, and the top stretchers lap-dovetailed into ends and mortised and tenoned into the intermediate ends. The drawer sides should be double stop-housed into the fronts or dovetail-housed because of the pro-

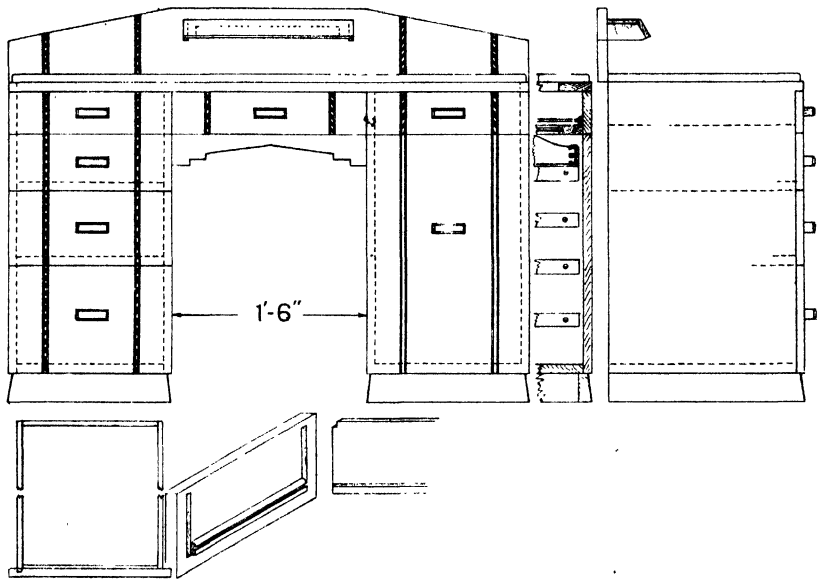

BUREAU IN OAK

Length 4 ft., Height 2 ft. 6 in., Depth 1 ft. 6 in.

jection over the carcass edges. To take the drawer bottoms the sides may be grooved in the solid or have a grooved slip as shown for the drawer fronts. The bottoms of the pedestals can be jointed with a rebated tongue and groove or lap dovetail. Banding $\frac{5}{16}$ in. or $\frac{3}{8}$ in. wide will be quite suitable.

Dwarf or Lowboy Wardrobe. Machine-planed oak, $\frac{3}{4}$ in. thick, is recommended for this job, as it will save a lot of hard work, tend to simplify it, and ensure more accurate results. Satin walnut, canary or red deal would be suitable for the top and bottom. The joint illustrated is the taper dovetail housing, and is recommended for fixing the carcass together; it is not very difficult to make and

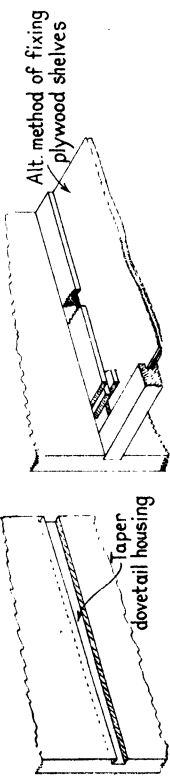
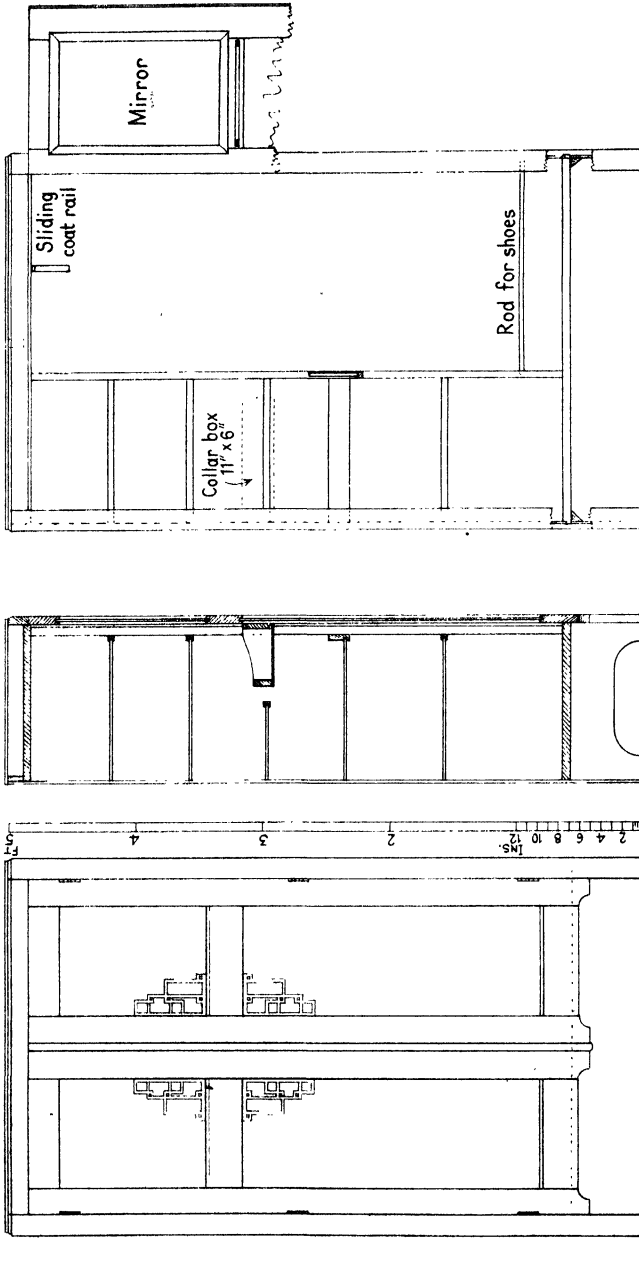

5 FT. BY 3 FT. OAK WARDROBE

is an excellent joint for wide surfaces. Each joint is fitted to within $\frac{1}{2}$ in. of the face edge; when all the joints have been fitted, finally glue and drive home with a mallet or hammer, using a piece of hardwood to protect the edges—when the joints will grip from front to back. The stiles or pilasters to which the doors are hinged



STOOL IN OAK

are fitted to the ends with a tongue and groove joint and may be strengthened with a few glue blocks in the corners.

The cavity at the top is covered with 5 m.m. plywood; this dispenses with a dust trap and forms a useful shelf.

The mirror may be silvered sheet or $\frac{1}{4}$ in. plate having a mitred frame fixed to the door with brass screws, or a frameless mirror can be substituted.

The tie rail may be of wood or metal and fixed underneath the mirror. A $\frac{5}{8}$ in. dowel rod will make a suitable shoe rack.

The "fret" in the corner of the panels is cut from oak veneer and may be fixed before or after the polishing is done. If fixed after polishing, shellac will be found an excellent substitute for glue.

Occasional Table. This is made entirely of $\frac{1}{2}$ in. oak, and may

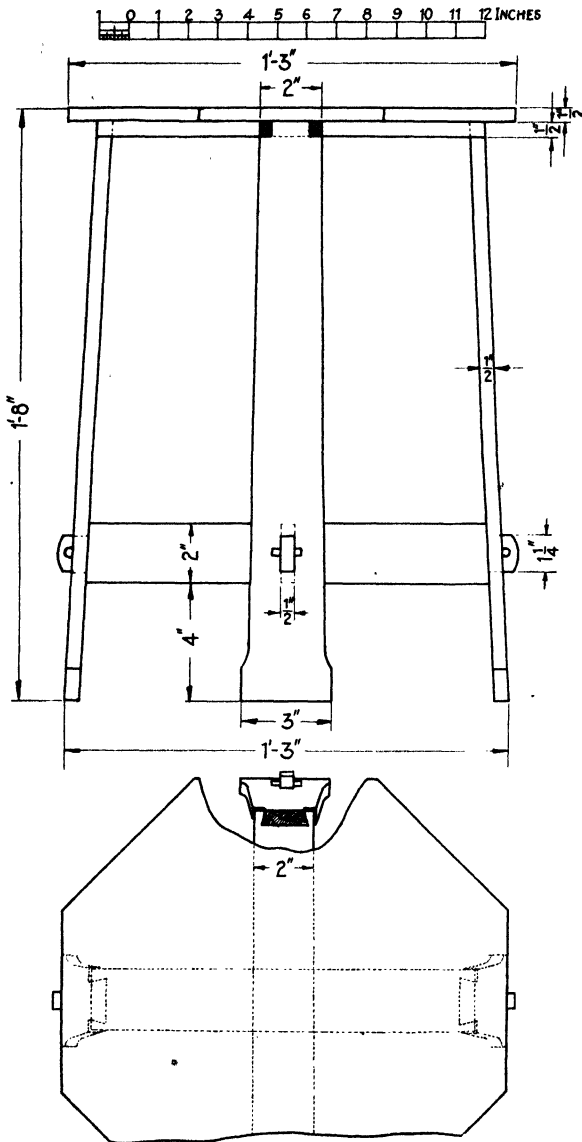

OCCASIONAL TABLE

have an octagonal or circular top. The rails are halved together—the top ones dovetailed into, and the bottom ones tusk tenoned through the legs and pinned. The table, although light, is quite rigid and strong, due to the bottom rails being placed on edge. A square, octagonal or circular shelf could be added. As the construction is comparatively simple, a table of this description will give the less skilled boy an opportunity of achieving something worth while.

Folding Ironing Table. This table is quite rigid and folds up perfectly flat.

The top two drawings show the elevation of the top and its plan from underneath. At the left hand end is a sheet of asbestos

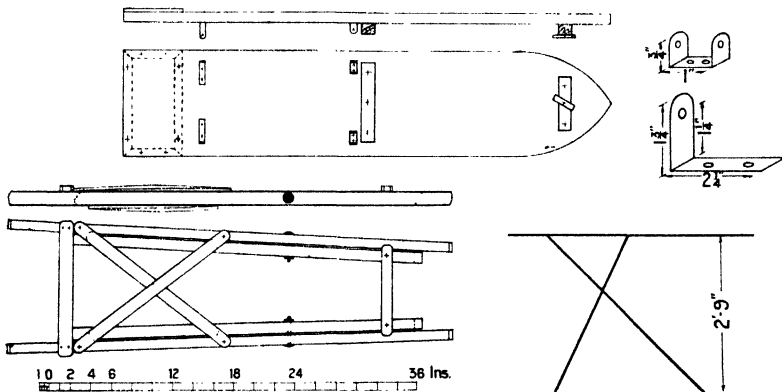

FOLDING IRONING BOARD

screwed down in a light frame. Then come the angle irons on which the long legs pivot. The two (channel)  irons are next. They take the ends of the short legs which are drilled *in situ* to take split pins. These are fastened to the underside of the top by a length of light brass chain. Drawings of the ironmongery are given on the right.

The middle batten can be omitted if desired, but as it takes most of the middle leg thrust and prevents the top from warping it is better included. The right-hand batten has a turn-button for fastening down the understructure.

Bolts should be fitted with heads outside, and the screwed ends split with a hacksaw and spread with a screwdriver or cold chisel to prevent the nuts from working loose.

The struts and ties are drilled, countersunk and screwed to the legs.

A piece of felt should be stretched over the ironing surface and tacked underneath.

Folding Card Table. The top is of plywood on a bridled or doweled frame. Good leather cloth or baize should be tightly

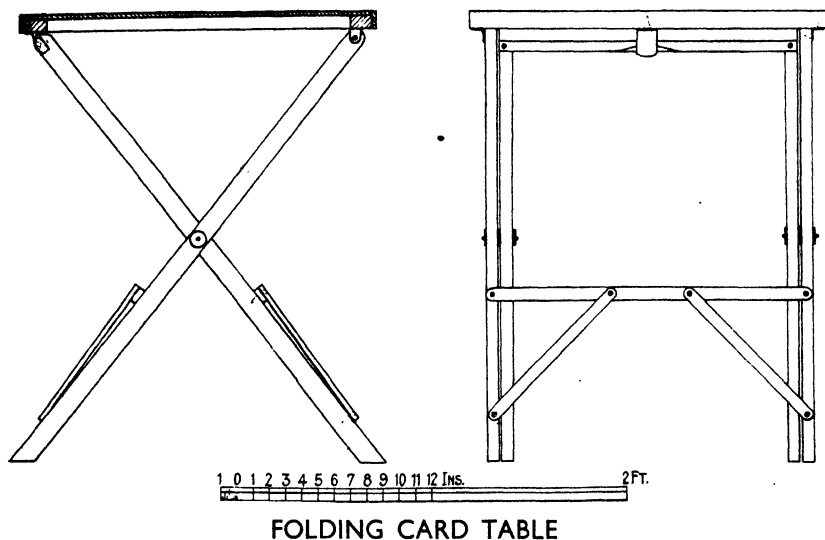

FOLDING CARD TABLE

stretched and fixed with the pins fastening the moulding which is planted round the edge.

The table top is hinged to the outside legs by round-headed screws passing through angle-irons screwed to its underside. When the table is in use, the inside legs are held in position by a strong metal clip firmly screwed to the other side of the framework.

Rivets and washers, or bolts and washers, should be used for hinging the leg frames together. If bolts are used each head should be on the outside, while the screwed end, after having the nut tightened up, should have a hack saw cut made in it. This must be opened with screw-driver or cold chisel so that the nut cannot work loose.

The tie bars and struts may be fixed in the upper part of the frames. This arrangement will give more leg room, but the table will not be quite as rigid.

Folding Work Table. Three frames hinged together are the basis of this portable table which folds flat when out of use.

The two side frames *B* have their rails tenoned into the stiles, one of which, on each frame, has a barefaced tenon at its upper end. This tenon, which fits into a mortise cut in the rebated distance-piece *C*, prevents lateral movement of the legs when the table is erected.

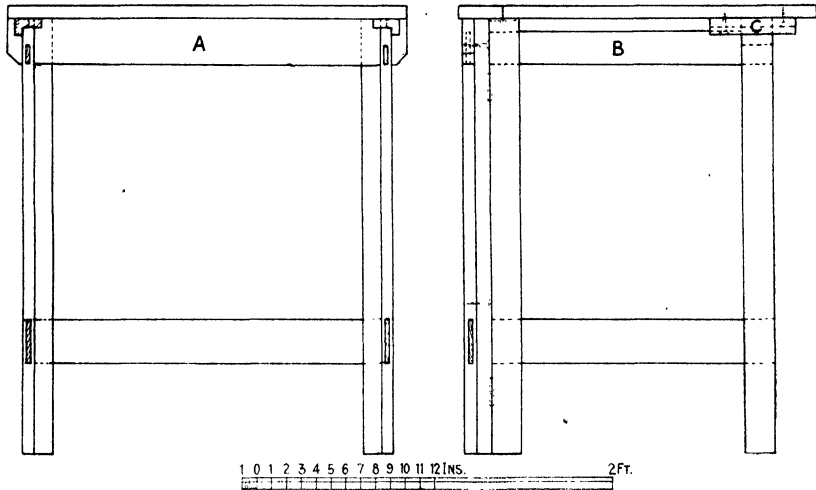

FOLDING WORK TABLE

One of these frames—the one shown—is $\frac{3}{4}$ in. narrower than the other, and is hinged to a $\frac{3}{4}$ in. \times $\frac{3}{4}$ in. section strip screwed and glued to the front frame. This allows the other side frame to fold flat against the front frame and this frame to fold flat also. The hinges are inside the structure.

The front frame *A* has the bottom rail tenoned into the stiles which in their turn are tenoned into the top rail.

The top is in two pieces hinged together underneath. The leaf falls down and holds the folded wings together. The front 3 in. strip of the top is fastened to the top rail of the front frame by glue blocks, screws, angle-irons or plates.

To erect, lift the flap until the hinges bind slightly, and revolve the side frames till they fit flat against the rebates and the mortises drop on to the tenons.

The table is quite rigid, if properly made, and does not wobble in the least.

Small Coffee Table or Stool. Sixteen mortise and tenon joints are needed. This number can be reduced by two if an H-shaped understructure is adopted. The tenons may be pegged.

Five different ways of treating the rails are shown and three leg suggestions are also shown.

The mouldings round the top edge should be "stuck on" with

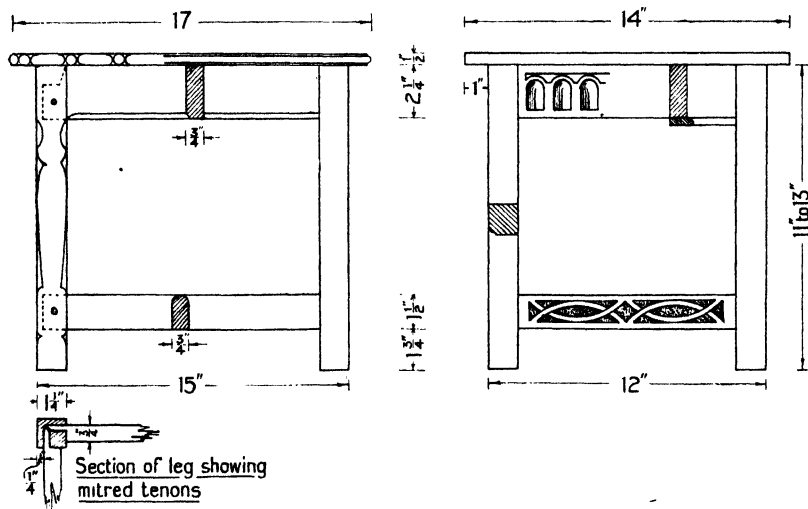

SMALL COFFEE-TABLE OR FIRESIDE STOOL

an astragal plane and the ball and sausage worked with a small carving gouge.

Coffee Table (circular top). The rails are cross-halved together and mortised and tenoned diagonally into the legs. A $\frac{5}{8}$ in. stopped chamfer is worked on the external angle of each leg, the bottom end merging into a volute cut into the adjacent faces of the legs. The top is of $\frac{1}{2}$ in. oak having a $\frac{5}{8}$ in. \times $\frac{1}{8}$ in. rim bent, glued and pinned to the edge. In working the legs a "cradle" will be of great assistance. If the top has to be jointed it will be advisable to dowel it.

Small Coffee Table or Stool. This is a type-design, capable of unlimited modification.

The rails are halved together and tenoned into the legs. The top is screwed to the top rails from underneath. Another shelf could be added to rest on the understructure.

Several decorative suggestions are shown. The legs may be made

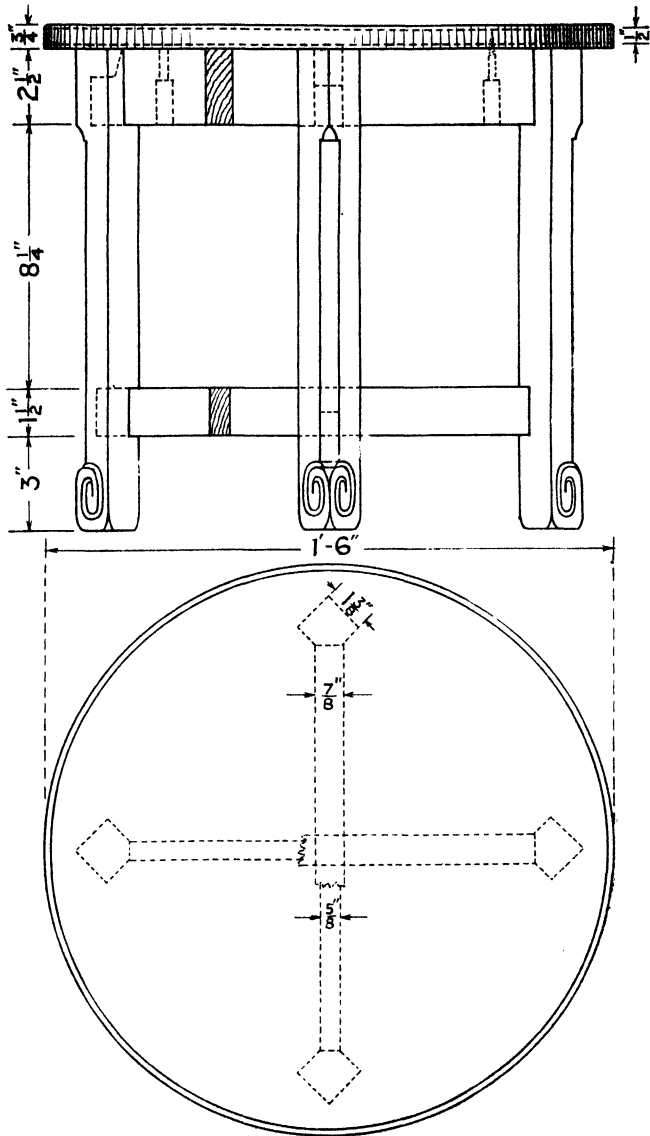

COFFEE TABLE IN OAK

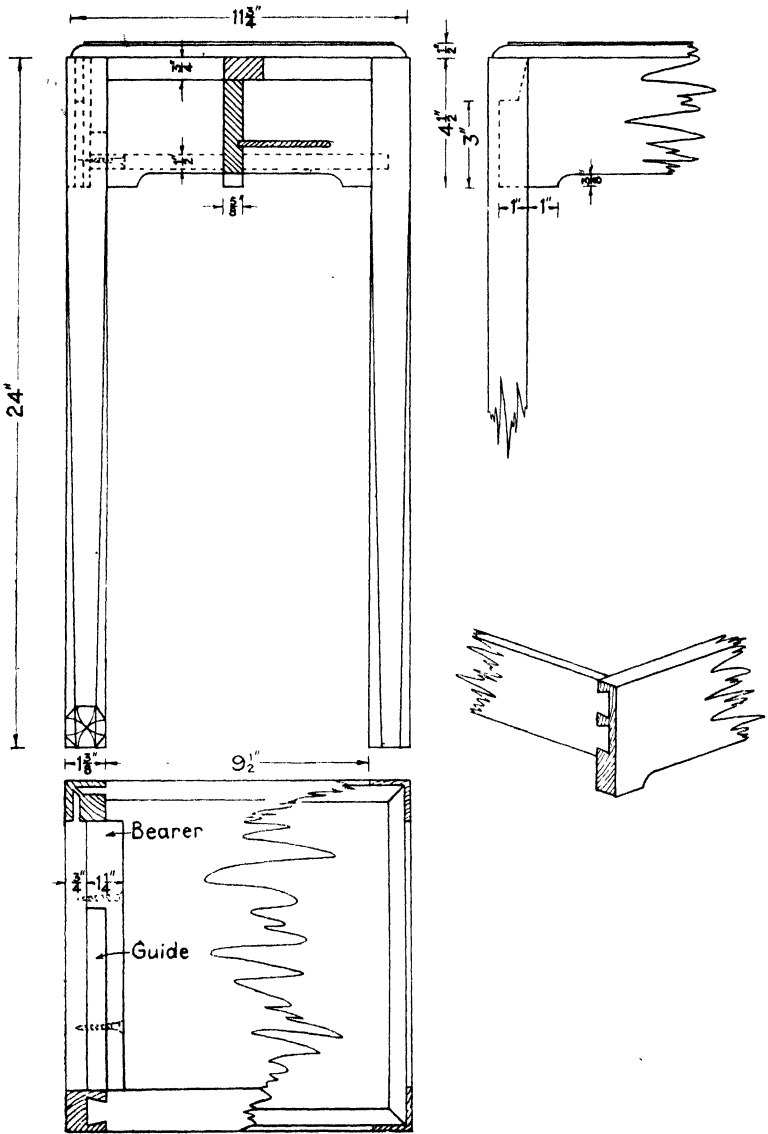

SMOKER'S TABLE WITH DRAWER

into irregular octagons by planing off the corners. In this case they could with advantage be made thicker.

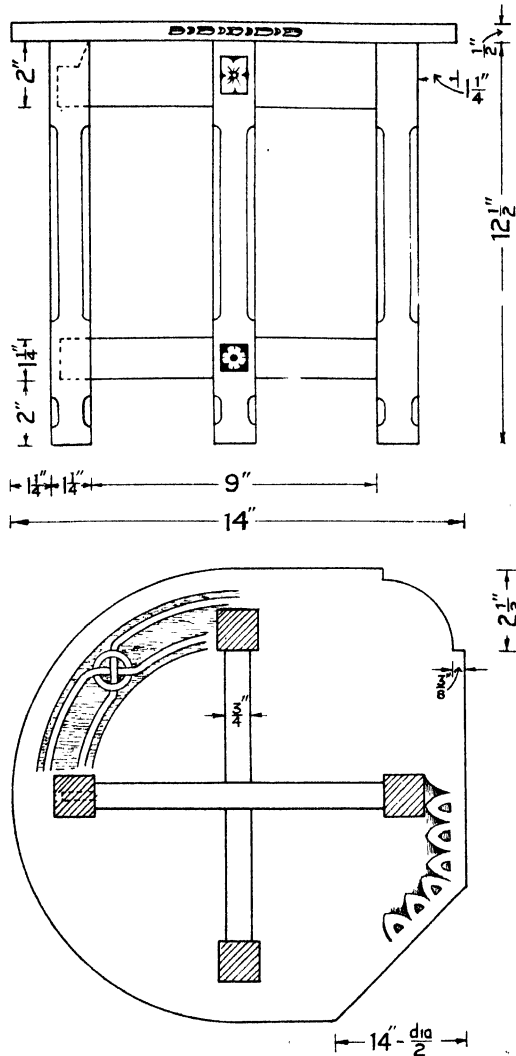

SMALL COFFEE TABLE OR STOOL

Book Table. The wood should be chosen to suit the design or *vice versa*.

The essential feature of this table is that the shelf below is

intended to hold books title upwards, while the legs in every case run through the top and form part of its decoration.

Many modifications are possible, some of which are shown.

In order from left to right the legs are shown: Chamfered;

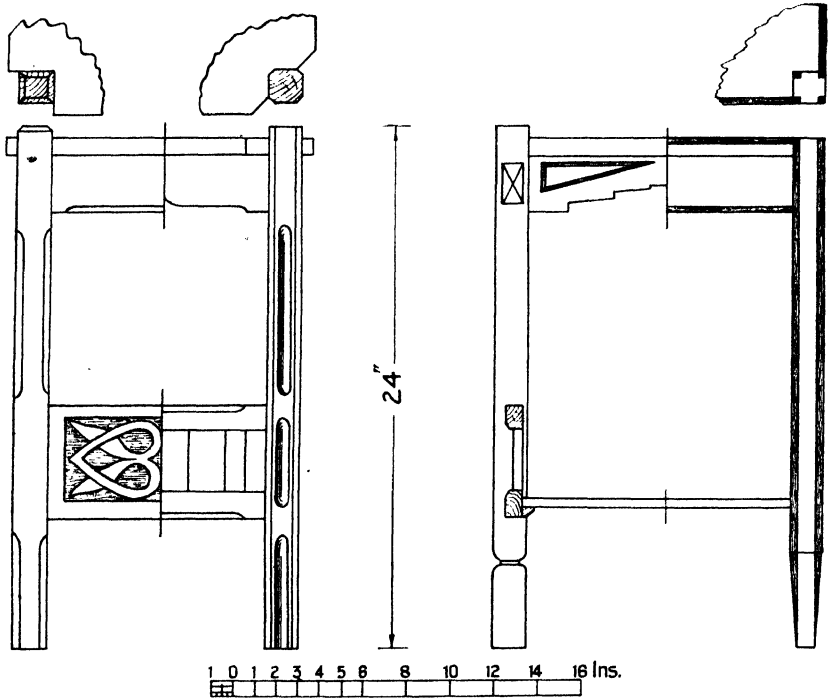

BOOK TABLE

dished and bevelled; square and carved; contrasting wood $\frac{1}{4}$ in. \times $\frac{1}{4}$ in. section glued into rebates.

The top rail is shown: Chamfered; shaped; stepped and inlaid; inlaid contrasting edge.

The understructure is a shelf with panel or framed ends to match the legs.

The top should match the other features and be buttoned or pocket-screwed to the rails.

Side Table. This table has two compartments the full length of the table which form receptacles for newspapers, magazines, etc. With the exception of the top and feet all the wood is machine-planed

to $\frac{3}{8}$ in. thickness. The top should finish bare $\frac{1}{2}$ in. thick, and the feet 2 in. \times 1 $\frac{1}{4}$ in. Three pieces, each 4 in. wide, are dovetailed into the top of the sides, and also trenched to receive the 6 mm. oak ply division. The sides and bottom are fitted together with four 2 in.

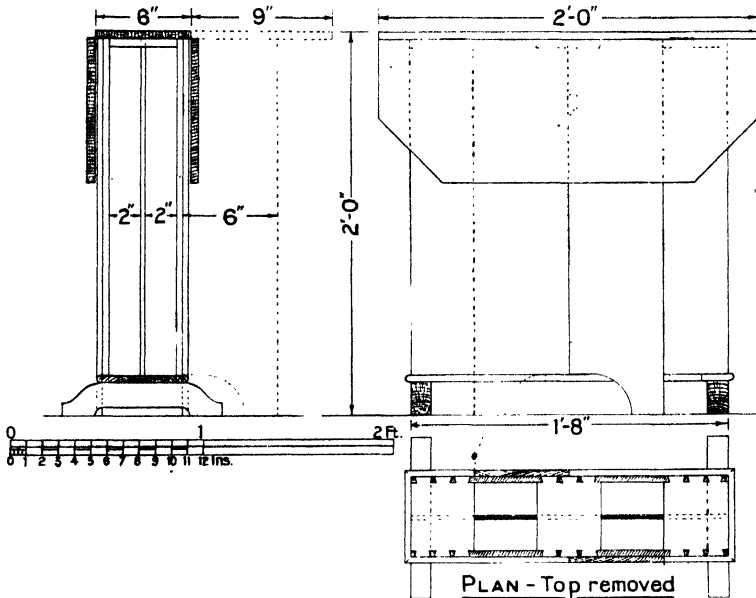

SIDE TABLE IN OAK

tenons mortised through the bottom. The bottom end of the division may be done similarly or merely trenched into the bottom. The supports for the leaves are hinged to the sides. In the end elevation the dotted lines show one leaf and support extended for use. The feet may be slot-screwed to the carcase or screwed through the bottom—the heads being slightly sunk and pelleted.

Occasional Table. This looks well made up in oak. The broad surfaces show the silver grain to advantage.

After the upright is planed, the shelves must be cogged into it while one piece of the base frame is tenoned into it at the bottom. The hand hole is bored, sawn and chamfered as shown in the drawing.

The base frame is halved together and the tenon pegged into the mortise.

The shelves may be any shape. It is advisable to make the stop housing on the underside of the shelf, diagonally across the grain

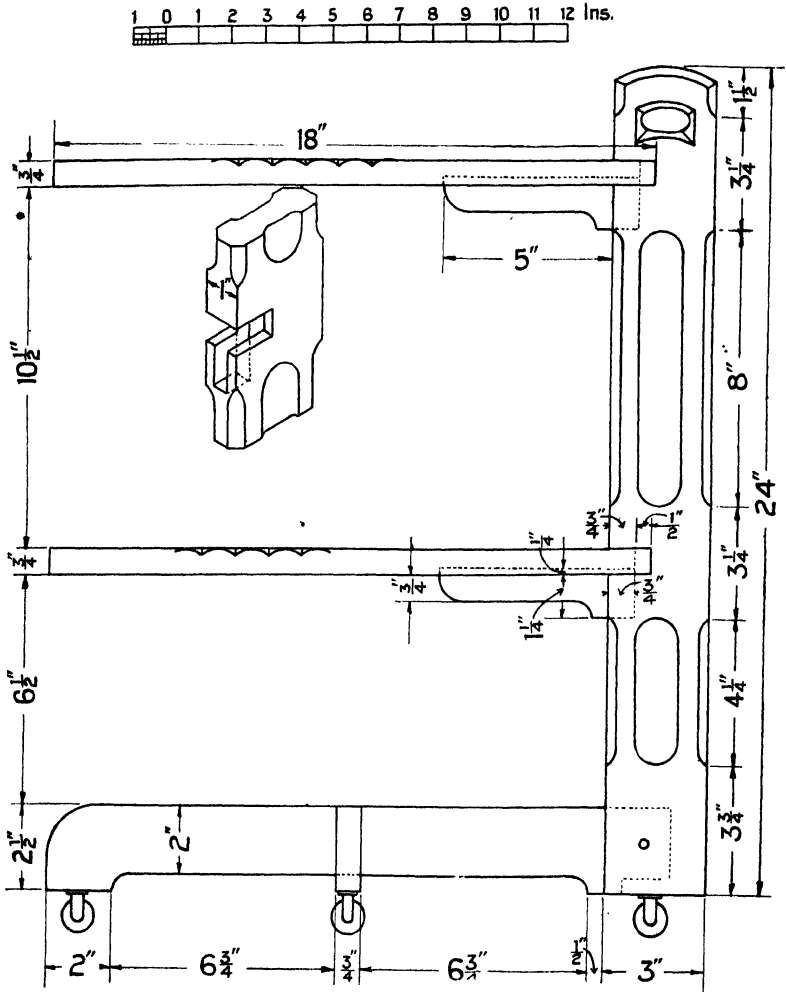

OCCASIONAL TABLE

for strength. The shelves may be dished or a light rim planted round the edge.

The brackets are tenoned full thickness and pegged into the upright. If, in addition, they are screwed into the shelves from below, any tendency for them to creep will be prevented.

Folding Tray Table. The principle of two rectangular frames, one pivoting on screws or dowels inside the other, is common. Here is a useful and amusing example to hold two loose octagonal or circular trays. By varying the length of the rails, the framework can be made to fit any shape of tray.

The inside frame should be made first.

The trays should be of stout laminated wood with a projecting rim, grooved to take the thickness of the ply, planted round the outside edges. Alternatively, a bead could be pinned round the top at, or near, the edge of each tray. Each tray rests on a rail and on wooden blocks pinned and glued to the inside end of the other rail.

There is no necessity for the tenons to come through the stiles. If the handle is tenoned into the long stiles, an extra inch or two should be left at the top of the stiles, until after the frame is glued up, to lessen the possibility of splitting. Dovetailing, as in the Three Tier Cake Stand, is an alternative way of fixing the handle.

Should there be any danger of the frames rotating when the table is in use, two blocks of wood hinged to the side of the bottom rail of the inner frame, one on each side of the bottom rail of the outer frame, should make the structure quite rigid and yet allow it to fold up easily. A hinged metal elbow may be substituted for the blocks.

Suggestions for simple modification and decoration are shown in the drawing.

Walnut is a suitable wood. The trays may be simply decorated by cutting through the top ply with a sharp knife and removing it in places. These shallow trenches should have bands, motifs, etc., glued into them to match the corner decoration, shown on the right-hand side of the drawing.

If the frame is made of canary, treated with glue size, and cellulosed black, the trays may be cellulosed to match the decorations of the room the table is to occupy.

Bedside Table. This is 2 ft. 5 in. high, 1 ft. 6 in. wide and 13 in. deep. The legs are $1\frac{3}{8}$ in. square and the rails are $\frac{3}{4}$ in. or $\frac{7}{8}$ in. thick, tenoned into them.

The top is of 5 m.m. plywood glued and blocked to the rails, and is strengthened by a tight fitting rail glue blocked between

—FOLDING TRAY TABLE—

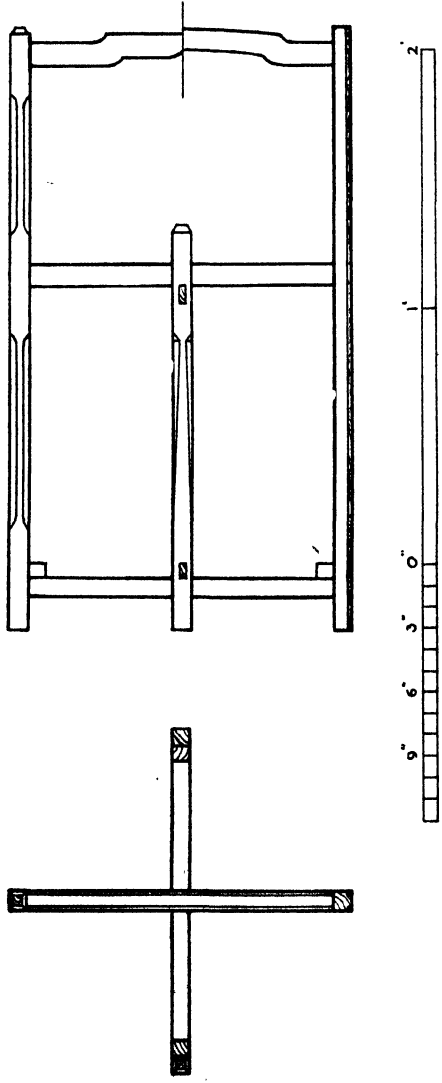

the front and back rails. The enlarged detail shows the construction of the moulded front, ends and top.

The shelf, which is of $\frac{1}{2}$ in. oak, finishes flush with the rails and legs. It may be fixed with buttons, pocket screwed, or glued and blocked.

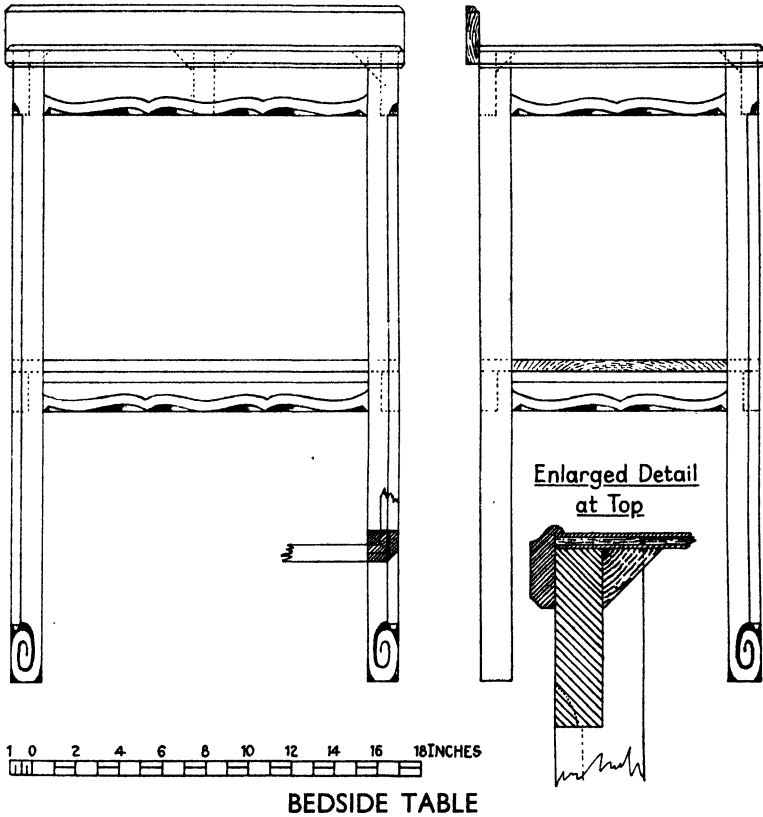

The width of the leg chamfers should not be less than $\frac{5}{8}$ in. They are worked with chamfer spokeshave, the stopped ends being finished with chisel, bullnose, scraper, and glasspaper.

The border line parallel to the butterfly chamfering can be cut with vee-tool or veiner. The volute is simply cut with carving gouges.

If the table is stained fairly dark, an antique effect can be got by lightly rubbing the borders on the rails and chamfers on the legs with No. 0 glasspaper, slightly smeared with raw linseed oil.

Finish with linseed oil. French polish and wax.

Sutherland Table in Oak. A table of this type will be found very acceptable where space has to be considered. When closed it can be used as a side table or placed in a bay window or recess.

It is light, rigid, and easily manipulated as it requires no brackets, slides, or swing legs. The leaves can be modified to taste, with square or octagonal ends or with round corners, 3 in. or 4 in. radius. The accompanying drawing gives all the necessary sizes, and details of construction. Oak lends itself to the kind of decoration which is merely suggestive and can be modified to individual taste; $\frac{5}{8}$ in. finished stuff can be used for the top and ends. The ends should be tenoned into the top clamps and into the feet. The projecting feet should be glued and screwed into position. The top stretcher is half-lap dovetailed into the clamps. The top which is free to revolve in either direction is fixed to the stretcher by means of a rebated disc $2\frac{1}{2}$ in. in diameter. The pins prevent the top from being rotated beyond the desired position when closing the leaves. As the joints between the leaves and top are square, there should be little difficulty in hinging with $1\frac{1}{2}$ in. or $1\frac{1}{4}$ in. back-flaps. If iron screws are used smear with Russian tallow. This will facilitate the driving and prevent corrosion due to the presence of acid in the wood. After the clamps and feet have been fitted, but before they are finally glued together, decoration and cleaning off should be done.

Mahogany Card Table. As will be seen from the illustration the top consists of two folding leaves. When not in use for card playing, it makes a side table.

The rails stand back $\frac{5}{16}$ in., on the bottom edge of which is planted a projecting fillet and bead. This is easily made by means of a $\frac{1}{2}$ in. astragal stuck on the edge of a $\frac{3}{8}$ in. board and forms the bead and one fillet.

The legs are shown worked in the solid, but a simpler method is to work the feet separately and fix by means of dowels. If the latter method be adopted, a templet of brass or zinc will ensure more accurate results. The construction of the leaves calls for very careful and accurate ploughing of the grooves in the framing, and rebating the panels to form the tongues to fit into these grooves.

To accommodate the green baize the panels which form the playing surface should not be less than $\frac{1}{16}$ in. below the frame. After

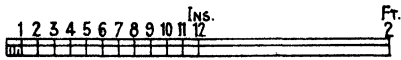
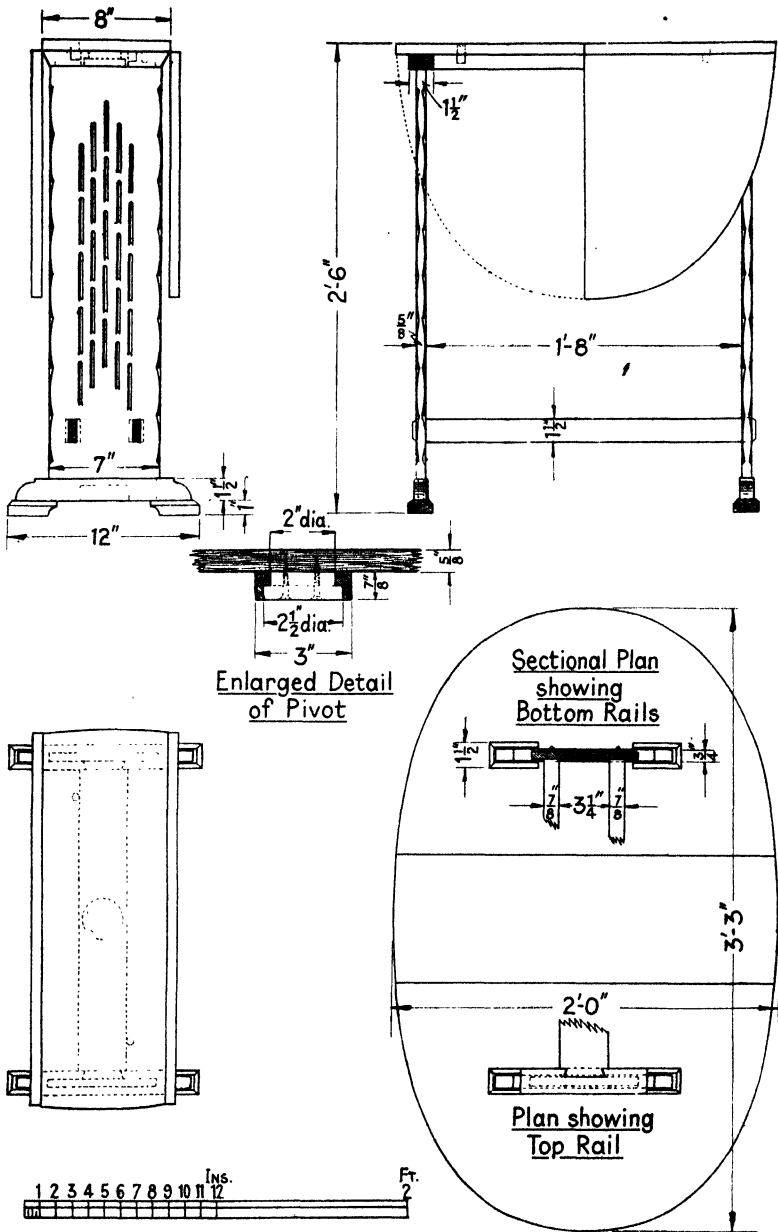

SUTHERLAND TABLE

the frame has been fitted, a cross tongue should be inserted into the stopped grooves in the mitres as shown by dotted lines. Before gluing together, the surface of the panels to which the baize is to be fixed should be well toothed to form a key for the glue.

On reference to the drawing it will be seen that a single piece of baize covers both the panels. The surface of the adjoining stiles—shown by dotted lines—will, in consequence, have to be reduced to the level of the panels, and toothed.

The drawer front is made the full depth of the rails, including the bead, and closes against the top and bottom stretcher rails. The runners are tongued into the bottom rail and glued and screwed on to the side rails. Guides for the drawer are glued and nailed on to the runners, flush with the side of the legs.

The method of finding the centre of the pivot on which the top revolves is clearly shown on the drawing. A line is drawn from the middle of one end of the open table to the position occupied by the nearest corner when it is closed. The bisector of the line, if continued until it intersects the middle line of the pivot-rail, gives the pivot centre.

NOTE. The fact that in the drawing the broken line showing the edge of the stile falls directly upon the pivot-rail centre line is a coincidence.

The hardwood pin and the path of same are shown when the table is open and closed. This pin prevents the top from being rotated too far in either direction.

Refectory Table. Finished sizes—

Trestles	4 pieces 2 ft. 4 in. × 3 in. × 2 $\frac{1}{2}$ in.
	4 „ 2 ft. 1 in. × 3 $\frac{1}{2}$ in. × 2 $\frac{1}{2}$ in.
Feet	4 pieces 5 in. × 3 $\frac{1}{2}$ in. × $\frac{7}{8}$ in.
Rails	2 pieces 4 ft. 10 in. × 2 $\frac{1}{2}$ in. × 1 $\frac{1}{2}$ in.
	1 piece 4 ft. 8 $\frac{1}{2}$ in. × 4 $\frac{1}{2}$ in. × 1 $\frac{1}{2}$ in.
Top. Frame	2 pieces 4 ft. 9 $\frac{1}{2}$ in. × 4 $\frac{3}{4}$ in. × 1 $\frac{1}{8}$ in.
	2 „ 2 ft. 9 in. × 4 $\frac{3}{4}$ in. × 1 $\frac{1}{8}$ in.
	1 piece 2 ft. 4 $\frac{1}{2}$ in. × 4 $\frac{3}{4}$ in. × 1 $\frac{1}{8}$ in.
Panels	2 pieces 2 ft. × 2 ft. $\frac{3}{8}$ in. × $\frac{5}{8}$ in.

The absence of deep rails makes a refectory table a very convenient dining table. This specimen will comfortably seat eight

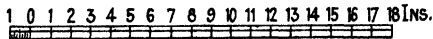
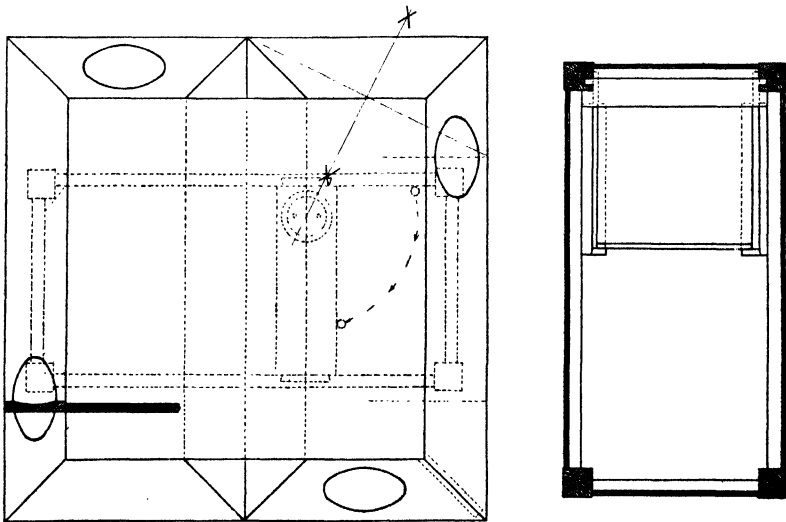
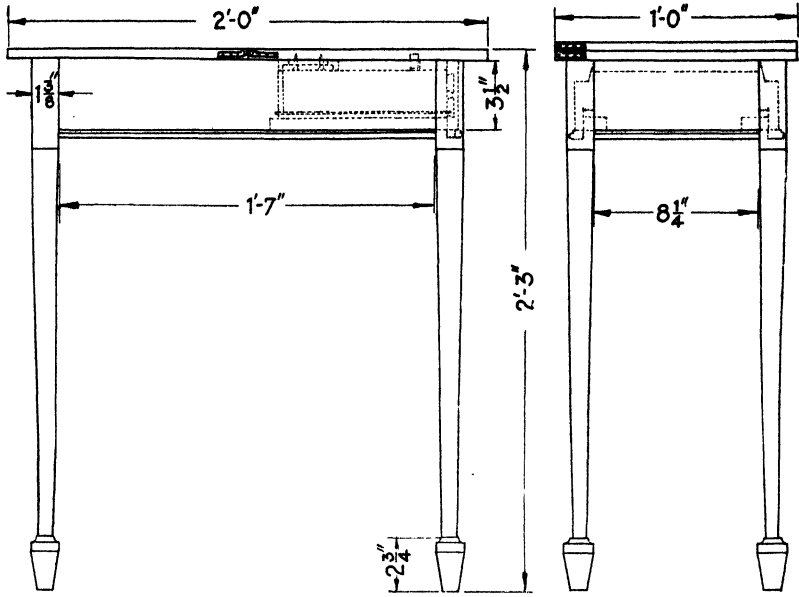

MAHOGANY CARD TABLE

people. It can be knocked apart in a few minutes, yet it is absolutely rigid when in use.

The wood recommended is well figured oak, the handsome sturdy nature of which is in complete harmony with this type of design. The shaping of the rail and cross-bar ends shown, is only a suggestion.

The uprights are tenoned into the cross-bars, wedged and draw pinned. They may be fitted dry or glued. If large adjacent holes

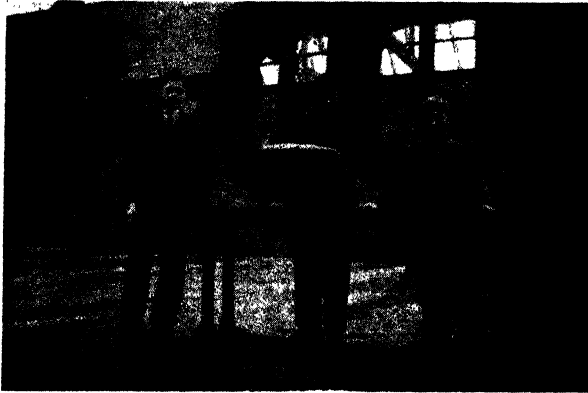

GROUP WORK

be bored in the middle of each mortise, the work will be simplified and accelerated. The shaping of the cross-bar ends should be done with a tenon or panel saw and iron smoothing plane. The decoration of the sloping surfaces is a set of tapering chamfers worked with spokeshave and plane.

The stopped chamfers on the rails and uprights can be roughed out with a drawknife or a tenon saw and mallet and chisel. They can be finished off with a small bull nose plane.

The feet are screwed from underneath.

The top cross-bars and the top rails are grooved on the inside to take the buttons which fasten the table top to the understructure.

In tenoning the rails great care should be taken that the shoulders are absolutely square and flat, and that the mortises which pass through them are tapered and set back about $\frac{1}{4}$ in. from the face of the trestle so that the wedges will pull the joints up tight.

The framework of the top is best tenoned and pegged, but dowelling will make a good job as there is little strain tending to

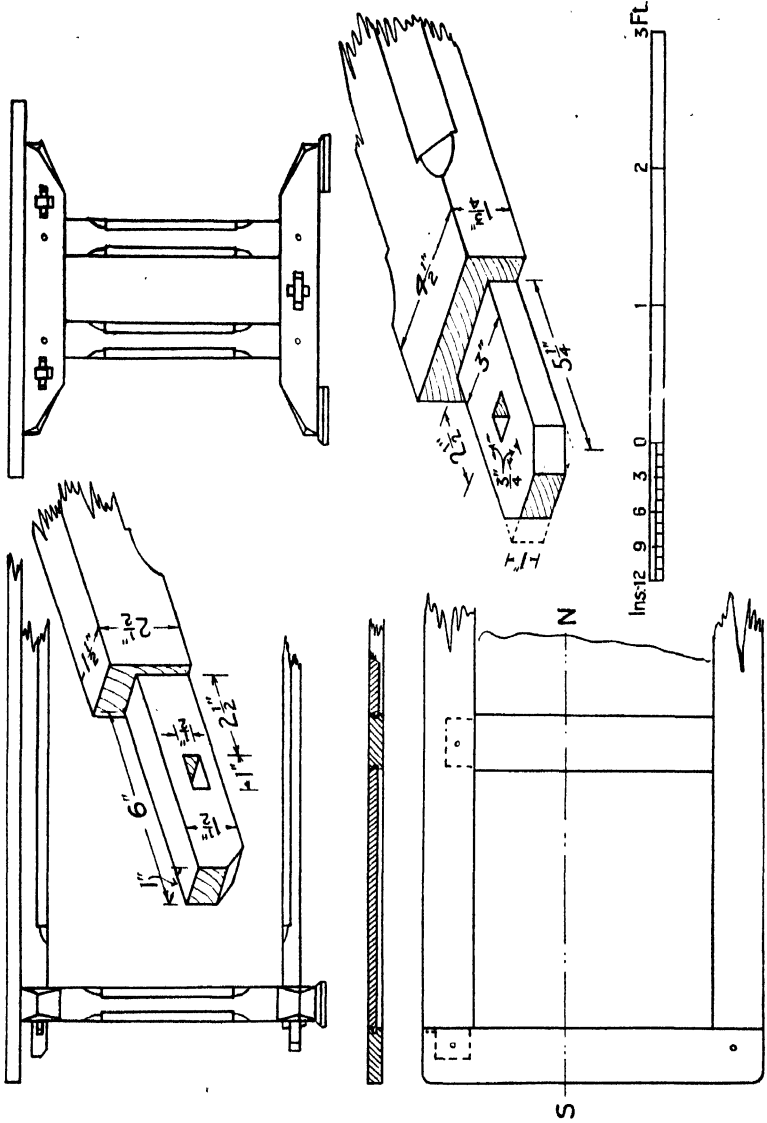

REFECTORY TABLE

pull the joints apart. A $\frac{1}{4}$ in. \times $\frac{1}{4}$ in. groove is ploughed along the inner edges and the tenons haunched to fit.

The boards comprising the panels should be carefully matched, each to each, so that the silver grain is displayed to the best advantage. Plain dowelled joints are quite suitable. The panels should be rebated to fit the grooves and must be fitted dry to allow for

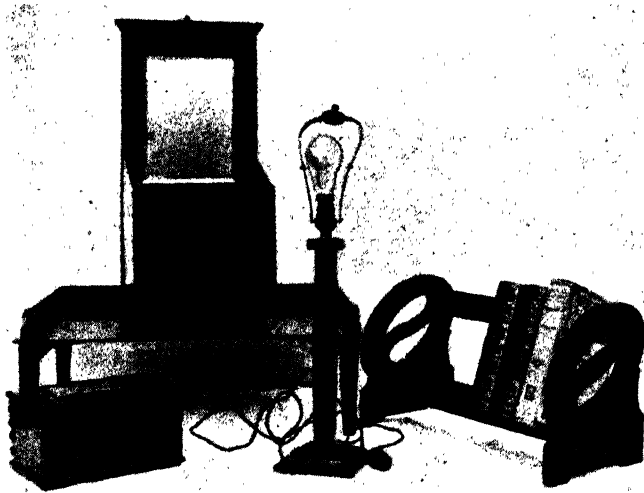

BOYS' WORK

shrinkage. If a vee-tool is used for emphasizing the upper visible margins of the fitted panels a better appearance will be secured.

A good finish can be contrived by filling the grain with a good wood filler and staining with creosote. This will bring up the silver grain. If a couple of coats of thin French polish be brushed on, glasspapered and wax polish applied, a lovely dull satin finish will be the result. The table should be dismantled for polishing.

Oak Trinket Box. Is made from $\frac{1}{2}$ in. oak planed to $\frac{3}{8}$ in. The construction is clearly shown in the drawing. The method of jointing is not usual but is characteristic of the material. Allow $\frac{1}{8}$ in. extra in width for sawing off and fitting the lid. When the sides and ends have been squared to length, and before setting out, set the cutting gauge to the thickness + $\frac{1}{8}$ in. for the projection of the pins and gauge a thin line on both sides of each piece. Number the ends,

1 to 4, of each piece where they are to join. Carefully measure and mark out as follows: Place the side and end, joint No. 1 vertically together in the bench vice—see that they pair—measure the pins and sockets and carefully square the lines across both ends with the scriber. Before removing from the vice, shade waste wood taking care that the pin on the side is directly opposite the socket on the

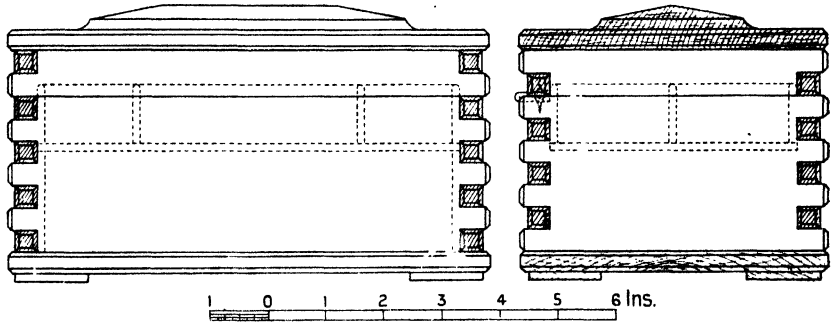

OAK TRINKET BOX

end. Remove, and square these lines on the Face Side to reach the gauge line. Repeat for each of the other corners. If this method is adopted and the work done from the Face Edge in each case, much confusion will be avoided. It will be an advantage if the chamfers are worked across the ends with a block plane before sawing the sockets. After the sockets have been worked, only the return chamfers across the thickness are left. These can be chiselled. Clean off before fixing together. In preparing the top for the lid the flat field or margin can be worked with a "Record" or "Stanley" fillister plane, and the scotia with a gouge or a No. 4 round.

Casket in Oak. This casket does not call for any outstanding skill in its construction, as will be gathered from the drawing. The tapered posts, hipped and moulded lid, etc., give solidity, balance, and character. No additional ornament is needed.

If the posts are ploughed in one length before being cut to size and tapered, the work will be simplified. The projecting mould, planted on the bottom edge of the box, is worked on the edge of a $\frac{3}{8}$ in. board with a $\frac{1}{2}$ in. astragal. This will produce one fillet and bead as shown. A chamfer may be substituted for the scotia (hollow). The portion of the grooves left after fitting the sides and ends into

the posts (due to ploughing), should be neatly filled, glued, and cleaned off before fitting the planted mould.

A piece of $\frac{3}{8}$ in. wood, long enough to make at least five feet, should be prepared and the hollow or chamfer worked all round. From each end saw off a piece as long as the width, shoot and work the mould across the end. Shoot and work mould on both ends of the

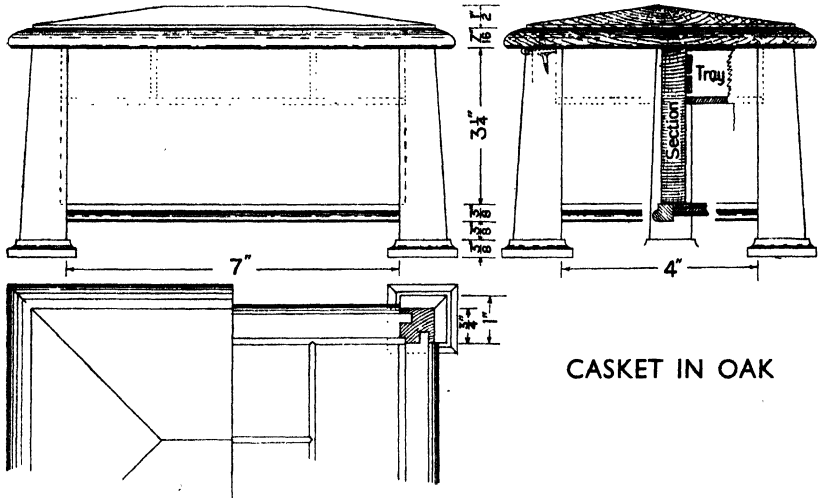

CASKET IN OAK

remainder and repeat as before. The feet should be glued and screwed or pinned to the posts. A piece of felt or baize glued to the feet will prevent the scratching of any polished surface on which the casket may be placed.

In preparing the lid, first rebate the necessary amount to enable the thumb mould to be worked. The end slopes should next be planed across the grain to within a bare $\frac{1}{8}$ in. of the mould to form the fillet. Finally plane the long slopes, taking care to get straight "mitres" where the surfaces coincide. The top is hinged as shown.

The tray, whose thickness should not exceed $\frac{3}{8}$ in., can be mitred, glued and pinned, or dovetailed. The divisions are vee-jointed and the bottom— $\frac{1}{8}$ in. plywood—glued and pinned to the frame. Mahogany is very suitable.

Cutlery Canteen. Oak is the most suitable wood for this piece of craftwork, which is within the capabilities of a good second year boy.

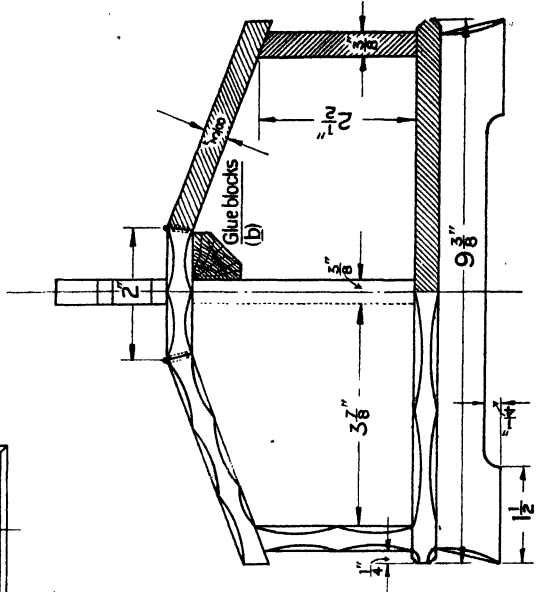
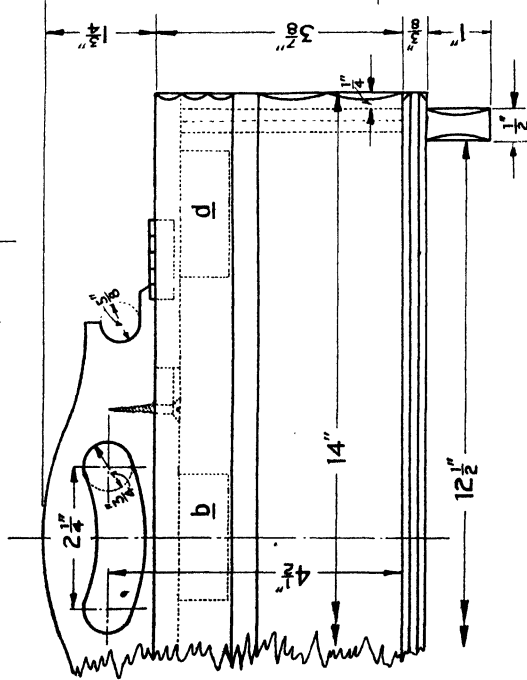
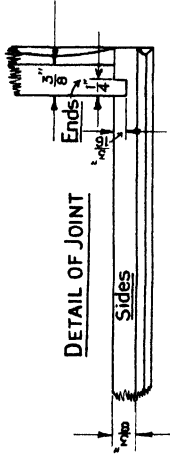
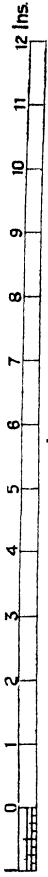

HALF SECTION

HALF END ELEVATION

CUTLERY CANTEN

Half-inch planed wood ($\frac{3}{8}$ in. finish) is suggested, and if nicely figured stuff is used the result will be much improved.

The butterfly chamfering which is characteristic of oak woodwork, is not too difficult and gives a pleasing effect to the whole. Plain chamfers could be substituted, care being taken to stop them at the necessary points, i.e. where the projecting ends and bottom coincide. The rebated tongue and groove joint is shown in the drawing; an alternative, although not so strong, is the housed joint. The division is housed into the ends. The handle is glued and screwed to the top piece, the whole being then glued and blocked to the division. The bottom is fixed with $\frac{5}{8}$ in. screws, after which the feet are worked, fitted and screwed into position.

One-inch or $1\frac{1}{4}$ in. brass butt hinges will be adequate for carrying the lids. It is suggested that the natural colour be retained as being the most suitable for the purpose for which the canteen is made.

Oil, and finish with white polish or wax.

Folding Stool. Two mortised frames, one fitting inside the other, pivoted together, make a suitable exercise for junior boys.

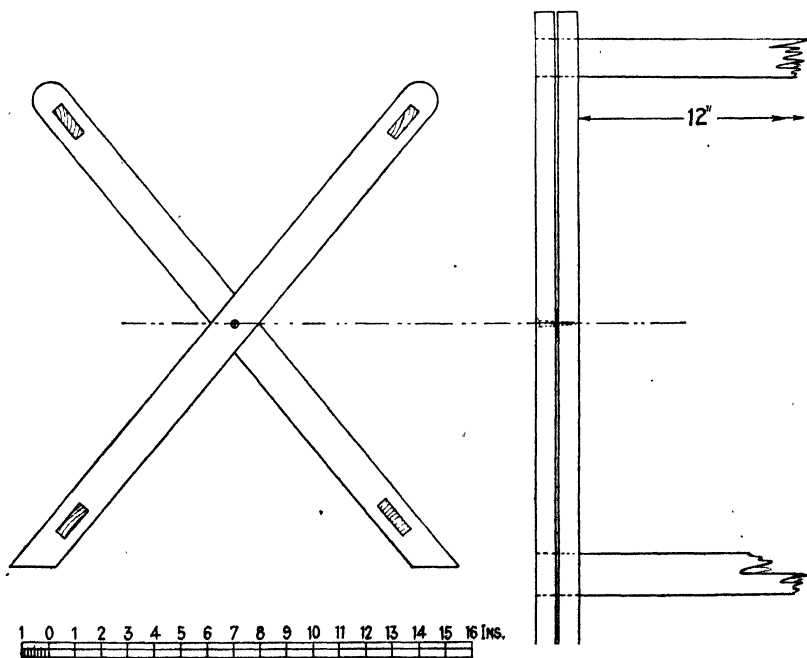

FOLDING STOOL

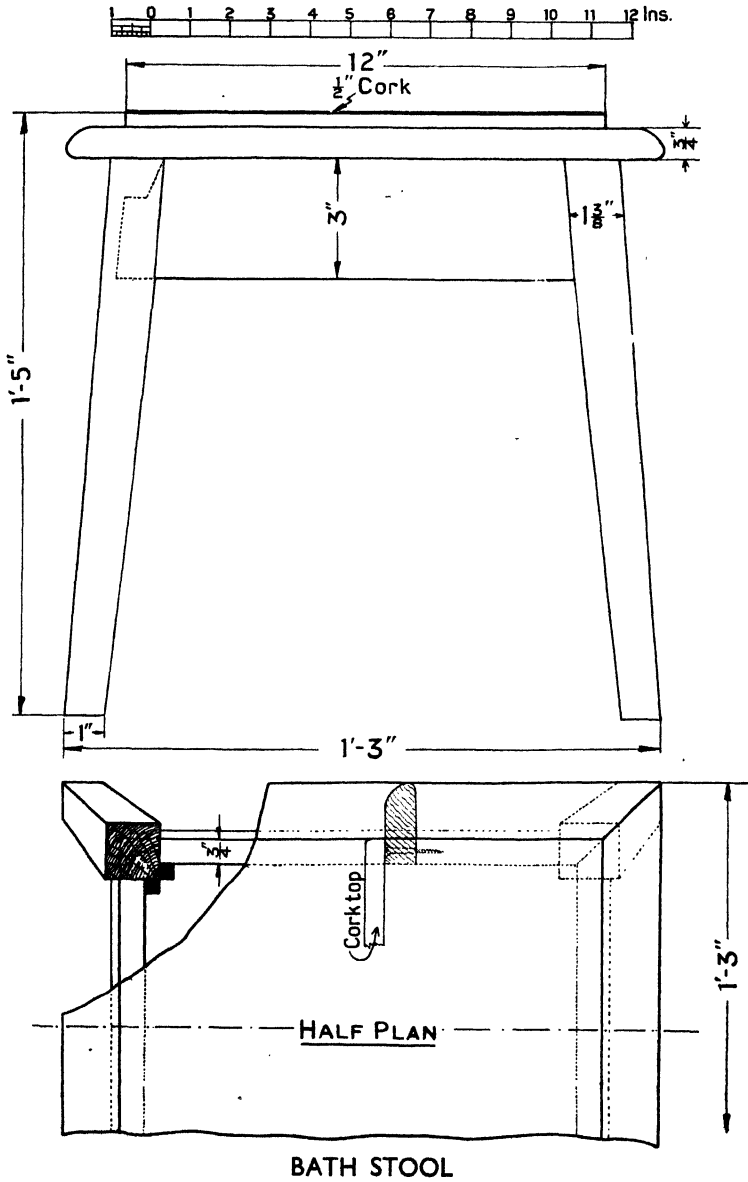

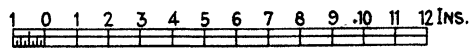
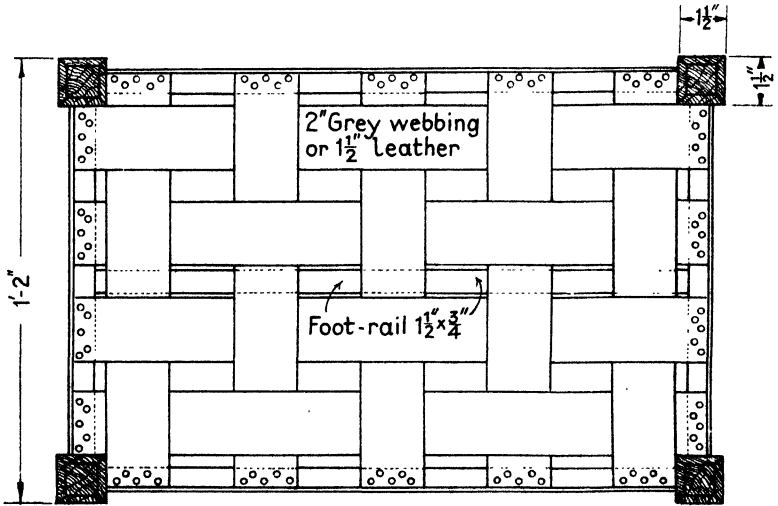
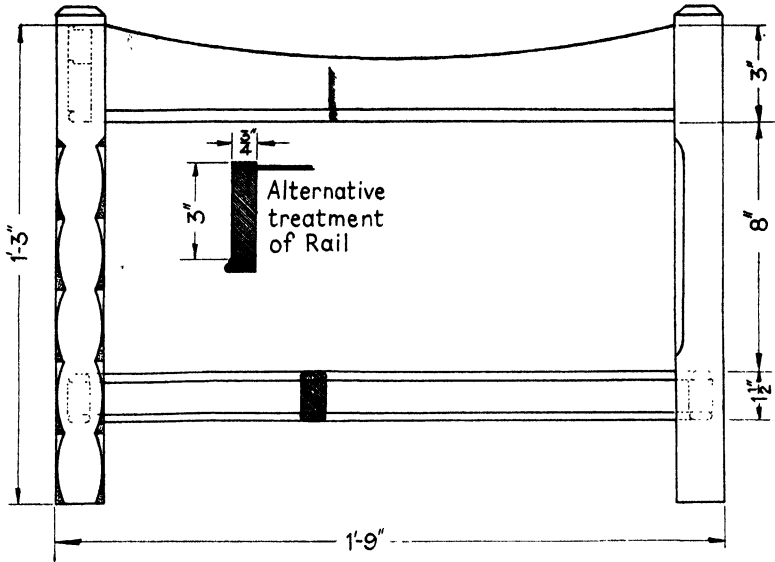

STOOL

The slung seat may be of leather, stair carpet, or deck-chair canvas fixed to the top edge of the top rails and wrapped right round them to take the strain off the tacks.

The pivoting can be done as in the folding card table or the ironing board.

Bath Stool. Expensive hardwood is not necessary for this stool. The legs are $1\frac{1}{2}$ in. square and are parallel for $3\frac{1}{2}$ in. from the top edge of the rail. They taper to 1 in. at the bottom.

Finished size of the rails 3 in. \times $\frac{3}{4}$ in. To finish the wood first give it a coat of strong glue size, allow to dry, and glasspaper. A coat of white cellulose paint can now be given. If a piece of 5 mm. plywood is fixed on the stool top a thin sheet of cork or a piece of

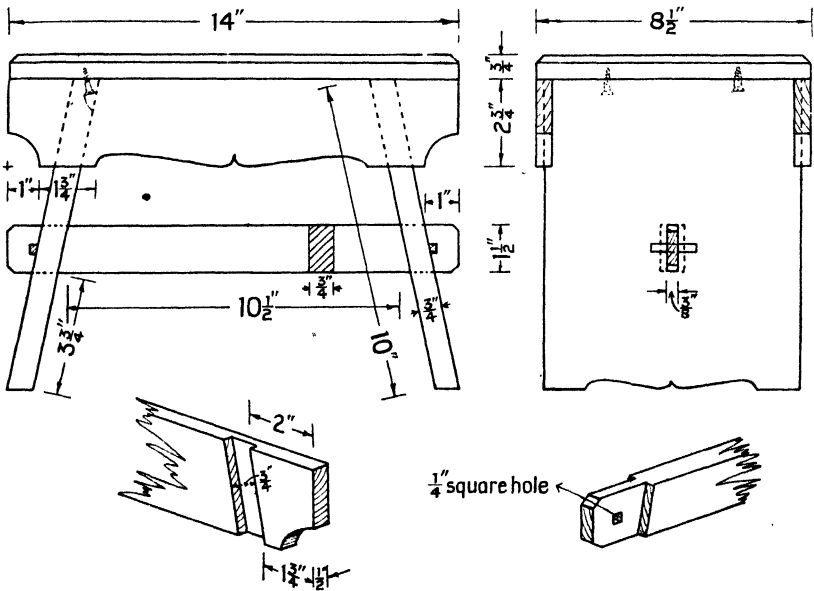

SMALL STOOL

cork lino may be used. Blocks glued to the rails and legs on the internal angles will strengthen the joints.

Small Stool. This is a handy, sturdy stool suitable for laundry, kitchen, or library use.

The top has a hand-hole and is pocket-screwed to the legs. Canary wood is a suitable material.

Footstool. A type-design which may be varied in all its dimensions and shapes. The simplest only are shown.

The tenons which are mitred can be haunched if desired.

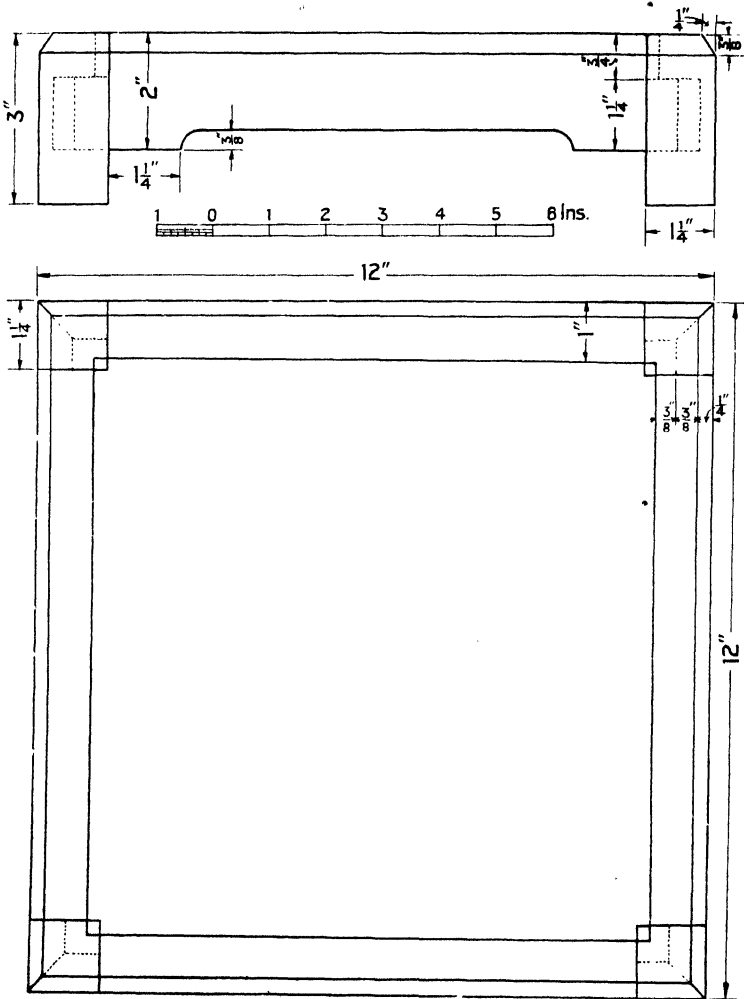

FOOTSTOOL

After the frame is glued up, the $\frac{1}{4}$ in. \times $\frac{1}{4}$ in. \times $\frac{3}{4}$ in. rebates for the corners of the knock-out top are chopped out.

The top should be webbed, stuffed, and upholstered in leather,

corduroy or rexine on a bridled or dowedled frame $\frac{3}{4}$ in. thick. The amount of clearance will depend upon the thickness of the covering material. The frame may be pocket-screwed to the rails and the webbing hidden by material to match the covering. Thin plywood may be substituted for webbing.

Little decoration is suggested as the stool is so low that any carving will have to be deep to be effective, and this will catch the floor dust, while any form of inlay is scarcely suitable.

If polished metal domes are fitted to the underside of the legs, the stool can be moved about with the foot.

Duet Stool. Although oak is suggested for making this stool, the design—with slight modification—is equally suitable for mahogany or walnut. For the duet stool $1\frac{3}{4}$ in. legs are shown, but for a single stool $1\frac{3}{8}$ in. would be quite adequate. In place of the usual webbing foundation for the seat, 5 m.m. birch plywood would be more satisfactory—no sagging of the seat or dust among the music. A strip of wood $1\frac{1}{4}$ in. \times $\frac{1}{2}$ in. should be glued and screwed on top of the plywood and should stand back $\frac{1}{8}$ in. from the face of the rails. This is to take the coverings and gimp. For a single stool a framed top hinged to the back rail could replace the drawer, the bottom being grooved into the rails or the edge rounded to form a bead and allowed to project $\frac{1}{8}$ in. beyond the surface of the rails and screwed or nailed to the bottom edge. To facilitate the removal of the music a hand hole is cut in the drawer bottom just inside the front and in the middle of its length—this enables one hand to push up the music and the other to lift it out.

Mortised Tray. Little need be said about the novel construction except that after the shape of the sides has been decided, a zinc template of the end will help greatly. The drawing shows four shapes and the setting out of the end in full.

The handles should be eased underneath in the middle to make gripping easier. Actually, when carrying the tray, the fingers are protected by the projecting ends so that they cannot be injured by knocking them against door casings or furniture. The tenon wedges must be inserted as shown, because if they are driven in parallel to the grain the sides of the tray may be split. The tenons are pressed tightly into the corners of the mortises when diagonal wedges are used.

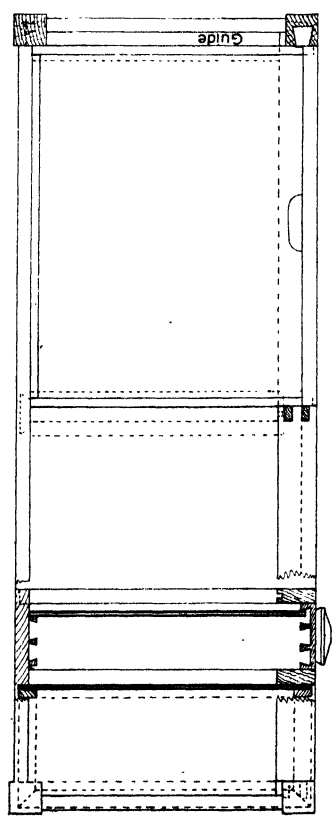
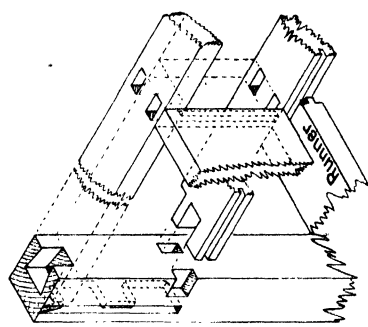
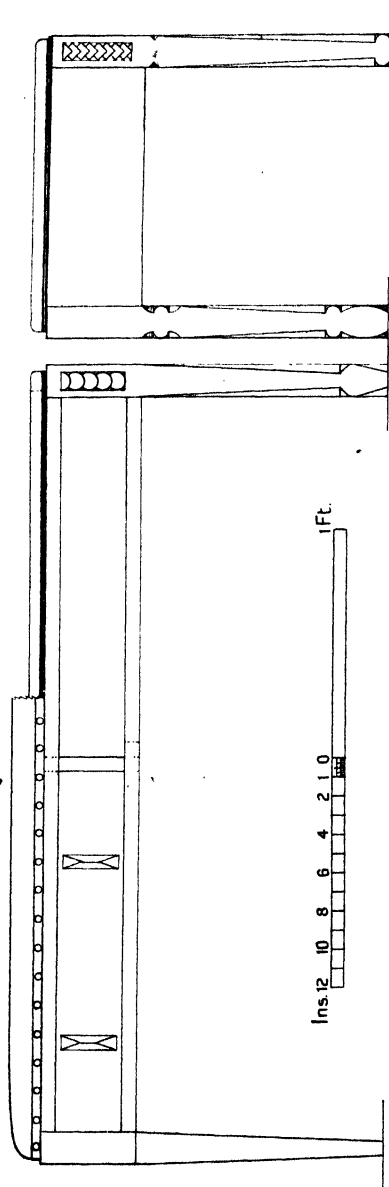

DUET STOOL

The underneath battens are glued and screwed and "Domes of Silence" added. They may, however, be dovetail housed into the solid bottom and glued only. The quarter ellipse moulding across the ends is glued and pinned.

If carving decoration is added it should be so flat that it gathers little dirt and is easy to keep clean. Inlaid lines are the most suitable

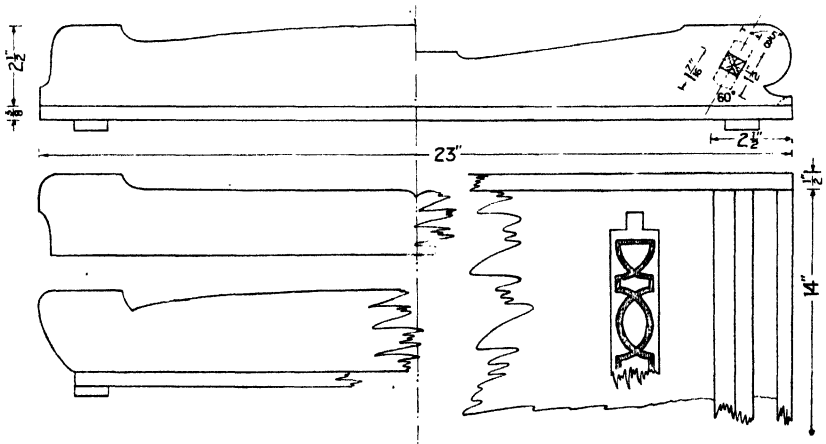

MORTISED TRAY

decoration. The drawing shows punching within incised lines on one face of the handle.

Folding Bed Tray (Oak). The illustration is that of a tray made from $\frac{3}{8}$ in. oak having a rim $1\frac{1}{2}$ in. deep with handles cut out of the end pieces, dovetailed at the corners. The legs which are 6 in. long can either be mortised and tenoned or dovetailed to the rails. The legs have a $\frac{1}{4}$ in. taper on two surfaces only, which starts $\frac{1}{2}$ in. below the bottom edge of rails. The rails which carry the legs are hinged to battens on the underside of the tray, and when in use are held by means of a wooden spring, which presses against the notched edges of the rails and locks them securely in position.

When not wanted, the legs are folded underneath the tray and will stay in that position until required again. A lighter but equally strong tray can be made by using 5 m.m. oak plywood instead of the $\frac{3}{8}$ in. oak mentioned above. If plywood is used, it will be necessary to substitute a 2 in. \times $\frac{3}{8}$ in. batten in place of the block to

which the spring is fixed. (See broken lines in front elevation.) This will strengthen the plywood sufficiently to counteract the pull of the spring when in use.

Inch brass back-flap hinges will be most suitable.

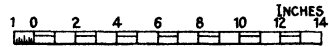
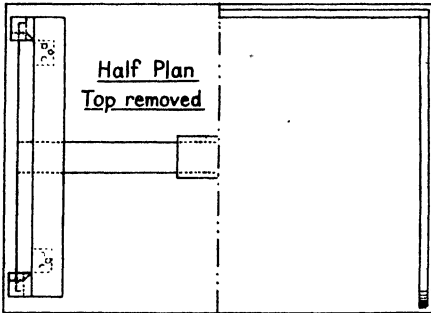
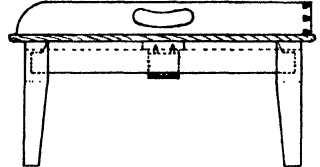
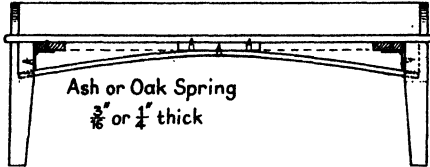

BED TRAY

Mirror Frame and Glove Box. In many modern houses the hall is so small that there is no room for the conventional hall stand with mirror. The article illustrated is big enough for most purposes and small enough to be fastened to a very short wall or hang from the picture moulding by light chains. If hooks are screwed underneath the box, clothes brushes can also be accommodated.

The construction is straightforward except where the box fits on to the back frame. The lid is notched into the frame stiles and runs right to the back, where it is screwed to the underside of the bottom rail of the mirror frame.

The ends of the box are lap dovetailed into the front, and may be either screwed or mortised into the stiles of the frame. The box back is of plywood, fitting into the stile rebates and fastened in position with beading.

The bottom shown is also of ply, fitting into a school-made rebated moulding planted round the lower edge of the box. A solid bottom can be substituted.

The frame tenons may be stopped so that they do not show at

the edges. The capping piece should be in harmony with the base moulding, and should be dowelled to the frame.

Four suitable types of shallow carving decoration are shown, but quite a different effect can be produced by omitting all

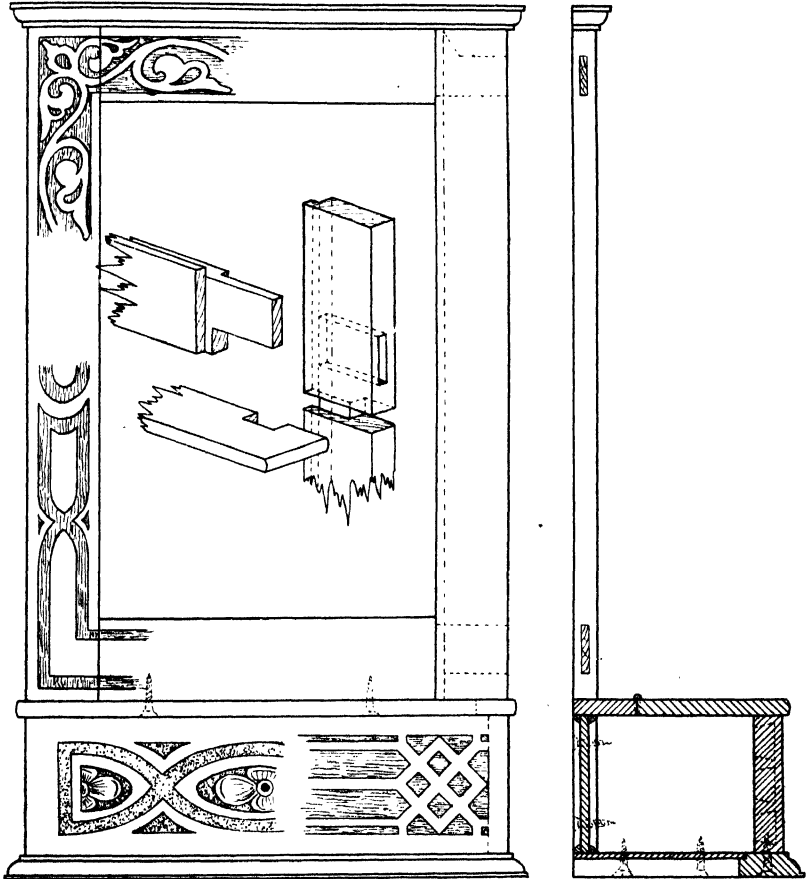

MIRROR FRAME AND GLOVE BOX

projections and inlaying the frame and box with contrasting bands.

Pivoting Shaving Mirror. An advanced craft exercise comprising four long and short shoulder bridles, four equal shoulder bridles and two mortise and tenon joints.

square and out of winding. The bridle joints may be pegged with $\frac{1}{8}$ in. pegs of a contrasting colour—four are shown so treated.

The pivoting is done with $1\frac{1}{4}$ in. \times 7 or 8 F.H. brass screws the shanks of which should be a sliding fit. Great care is necessary in centring or the frames will not be flush and will not revolve without catching.

The tenon should be wedged and its shoulders quite square or the outside frame will not fit the middle frame properly. The ends of its arms, where they pivot, are semi-circular.

Flush decoration with bands or strings is the only suitable kind as the article is essentially a bathroom fitting.

An oil finish is suggested.

Hall Mirror and Coat Rack. The overall sizes are: length 2 ft., height 1 ft. 4 in., depth $4\frac{3}{4}$ in.; oak is suggested. The sides are open as shown in the section, but could be modified by the addition of panels or another rail. The suggested decoration is done with a fluting gouge with a patera as a central feature. The mirror may be plain or bevelled. In making the pegs it will be simpler to do so in pairs. Prepare two pieces an inch or two longer than the total length of two pegs; at each end mark out and work the tenons. In the event of one or both being unsatisfactory, saw off and rework. When the tenons have been sawn successfully, mark out the remainder; saw and chisel the sloping notch on the top edge, after which saw and shoot each peg to length. Plane to slope on under edge; vertically chisel chamfered and rounded corner; file and glasspaper where necessary.

To avoid a long and short shouldered or sloping joint between the muntins and rails, rebate out the width of the opening plus the depth of the rebates in the muntins.

Fire Screen. Two alternative designs are shown on the drawing and four different methods of treatment for the panel by means of banding or stringing. The panel may be either rebated and beaded in, or grooved in solid. The following method is adopted for this style of foot. The front feet are fitted, marked, and screwed on dry from the back of the frame; they are then taken off and a $\frac{1}{8}$ in. oval brad driven into the jointed surface about $\frac{1}{2}$ in. away from the screw hole above and below it; the heads project $\frac{1}{8}$ in. and are filed to a chisel edge so as to enter the frame when the feet

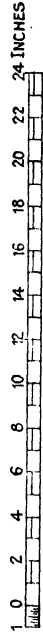
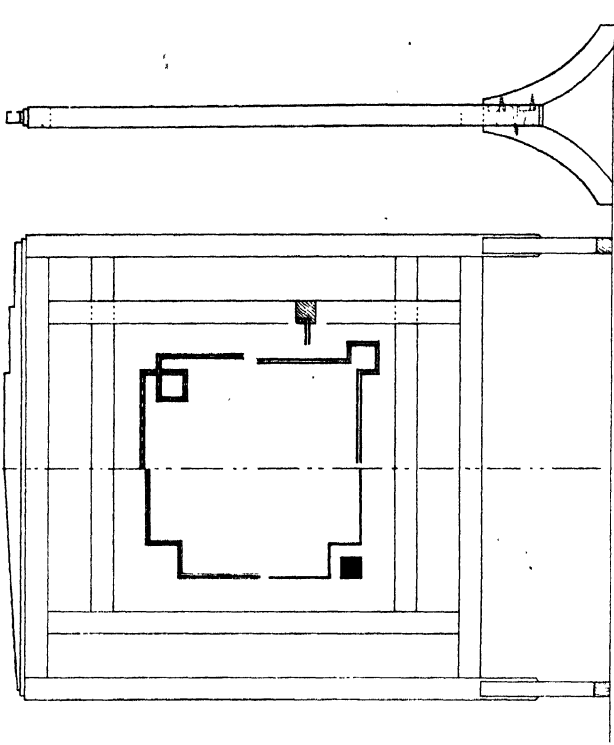

HALL MIRROR AND COAT RACK. FIRE SCREEN

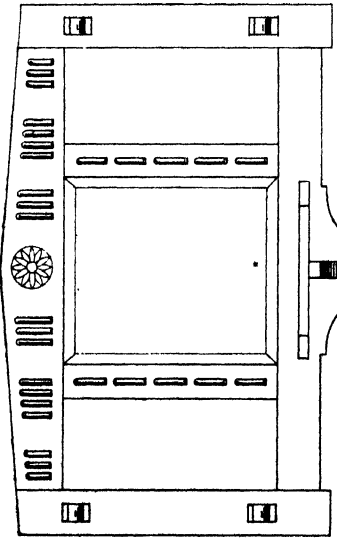

Section thro' mirror frame

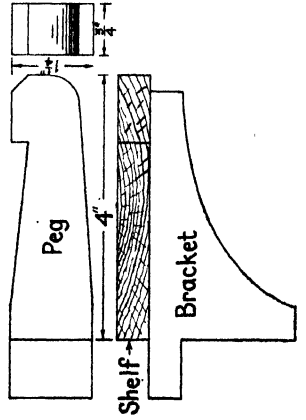
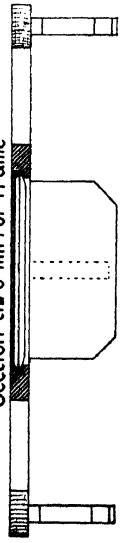

are finally glued and screwed. Two $\frac{3}{8}$ in. or $\frac{1}{2}$ in. screws should be driven into each of the other feet; the screw heads to project $\frac{1}{4}$ in. and suitable slots worked on the back of the frame and the feet fitted into position. Advantage should be taken of the square at the top of the feet to enable them to be driven home. To fix, finally glue and screw on the front feet followed by the ones that are slot screwed.

N.B. If single-sided oak veneered plywood be used for the panel, the trenches for the banding or stringing can be done with a cutting gauge and a suitable chisel. The veneer in this case is much thinner than the double-sided oak ply making it more suitable for inlaying. Should the double-sided be used, it may be necessary to insert a layer of veneer before laying the banding.

Light Fire Screen—

2 pieces 30 in. \times 1 in. \times 1 in.
2 „ 19 in. \times $2\frac{1}{2}$ in. \times 1 in.
2 „ $7\frac{1}{2}$ in. \times $2\frac{7}{8}$ in. \times 1 in.

This is a type-design suitable for modification by a boy.

The feet and uprights should be made first and jointed together. Before gluing them together the mortises for the rails should be worked.

The four screw hooks or screw eyes hold the dowel rods which run through the fabric filling the rectangle.

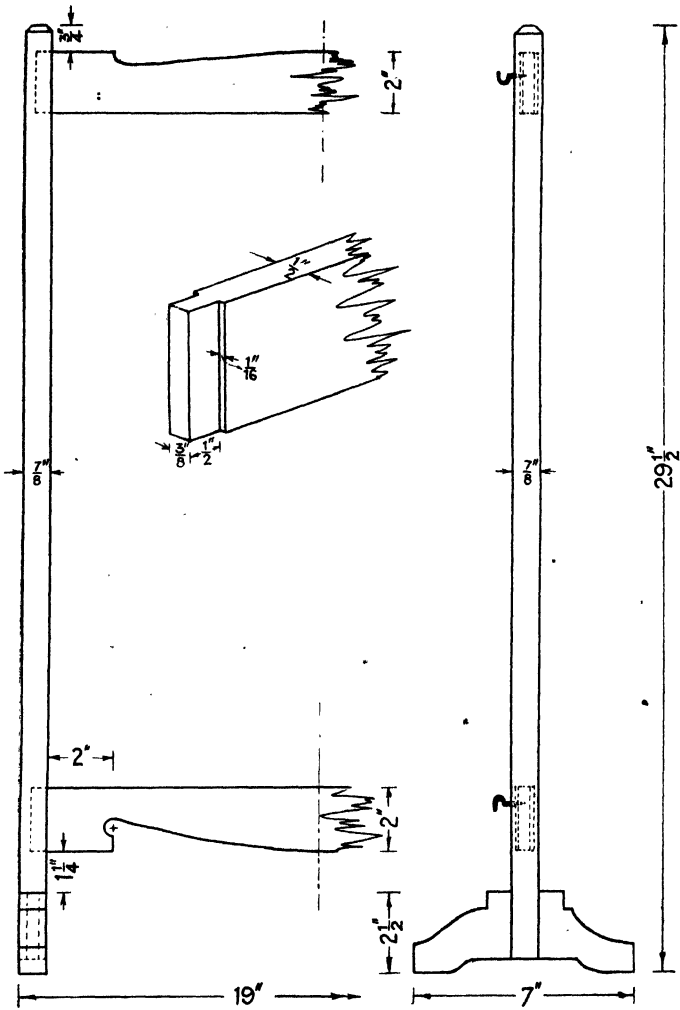

LIGHT FIREPLACE SCREEN

Shaving Cabinet with Mirror. If made in black walnut, decorated with contrasting bands, oiled and waxed, this cabinet can be both very useful and decorative.

First make the frame and glue up. The sides of the box are screwed from behind and the shelves are housed into them.

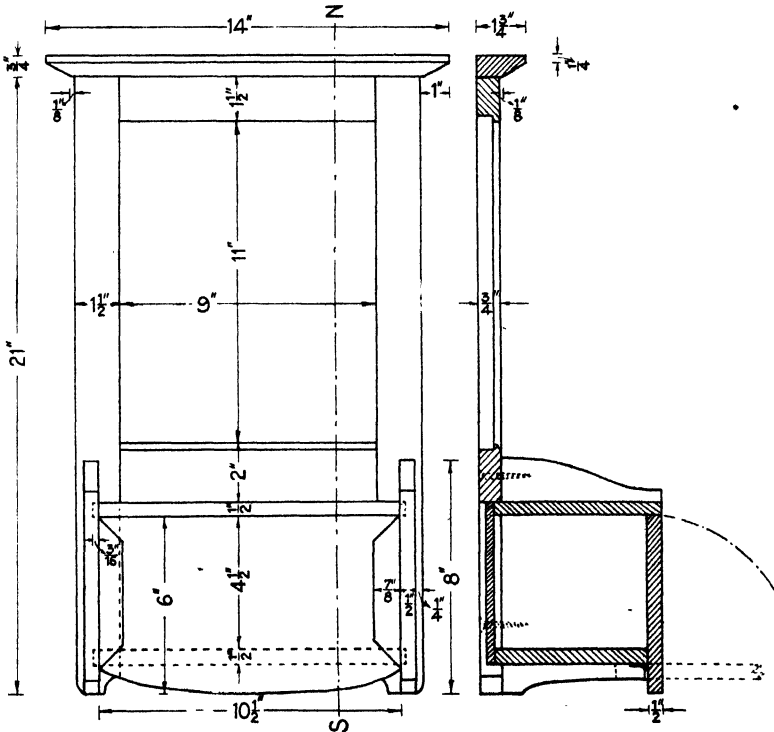

SHAVING CABINET WITH MIRROR

The front of the cabinet is hinged, and if fitted with a ball catch will fall down into a horizontal position when tapped at its lower edge. The front shown is clamped.

Wall Cabinet. Oak or mahogany is equally suitable for this piece of work. The photograph is that of a cabinet made of mahogany. The carcase is made of $\frac{1}{2}$ in. mahogany.

The doors are also made of $\frac{1}{2}$ in. mahogany but are veneered on both sides to prevent warping. The drawer fronts, being smaller and dovetailed to the sides, need only be veneered on the face.

The doors and drawers should be made and fitted before being veneered. After being laid, 24 hours at least should be allowed for the glue to dry thoroughly. The projecting edges of the veneer can then be trimmed with a finely set steel plane. With a cutting gauge the trenches for the banding can be cut through the thickness of the veneer and removed with a chisel or "scratch." Glue and

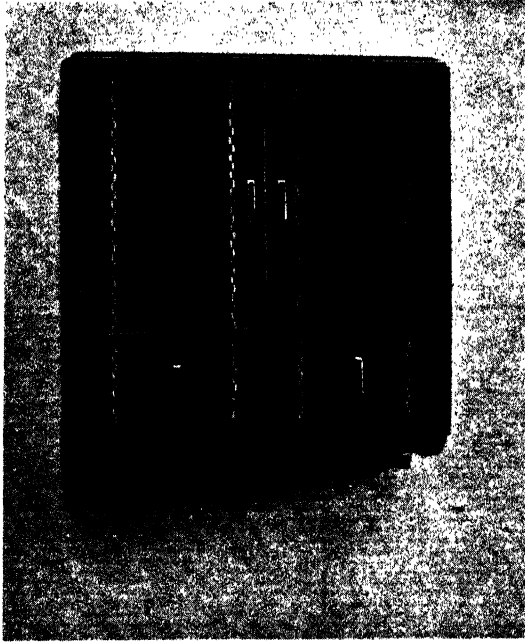

WALL CABINET

lay banding with the pane of a hammer. Do not clean off until the glue has thoroughly dried. For knife-cut veneer, a good sharp scraper and glasspaper will be sufficient, but if sawn veneer be used, a finely set steel plane will help to produce a better finish.

The division separating the drawers is $1\frac{1}{2}$ in. wide, stop-housed into the shelves with a guide of equal thickness, $\frac{1}{2}$ in. or $\frac{3}{4}$ in. wide. A division the full depth from front to back may be substituted.

The handles are made from a length of $\frac{1}{2}$ in. mahogany glued and screwed from the inside.

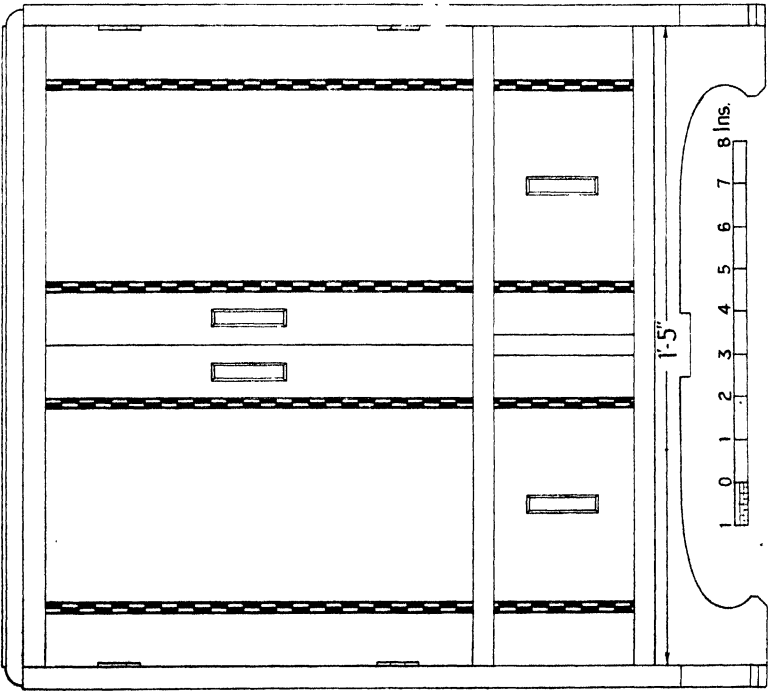
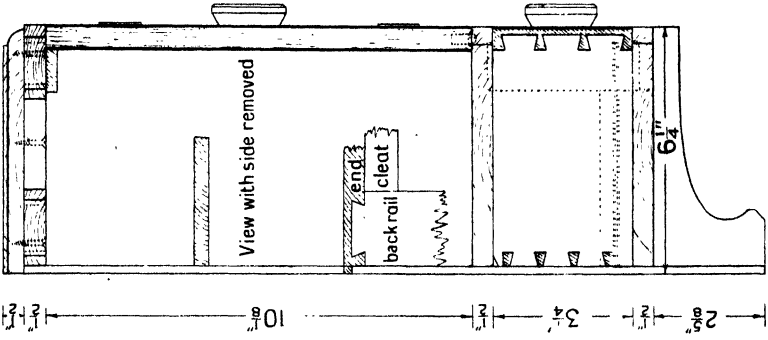

WALL CABINET IN OAK OR MAHOGANY

Medicine Chest and First Aid Cabinet. A type-design introducing the making and fitting of a door and a drawer. Only flush decoration is suitable, as the cabinet must be kept perfectly clean.

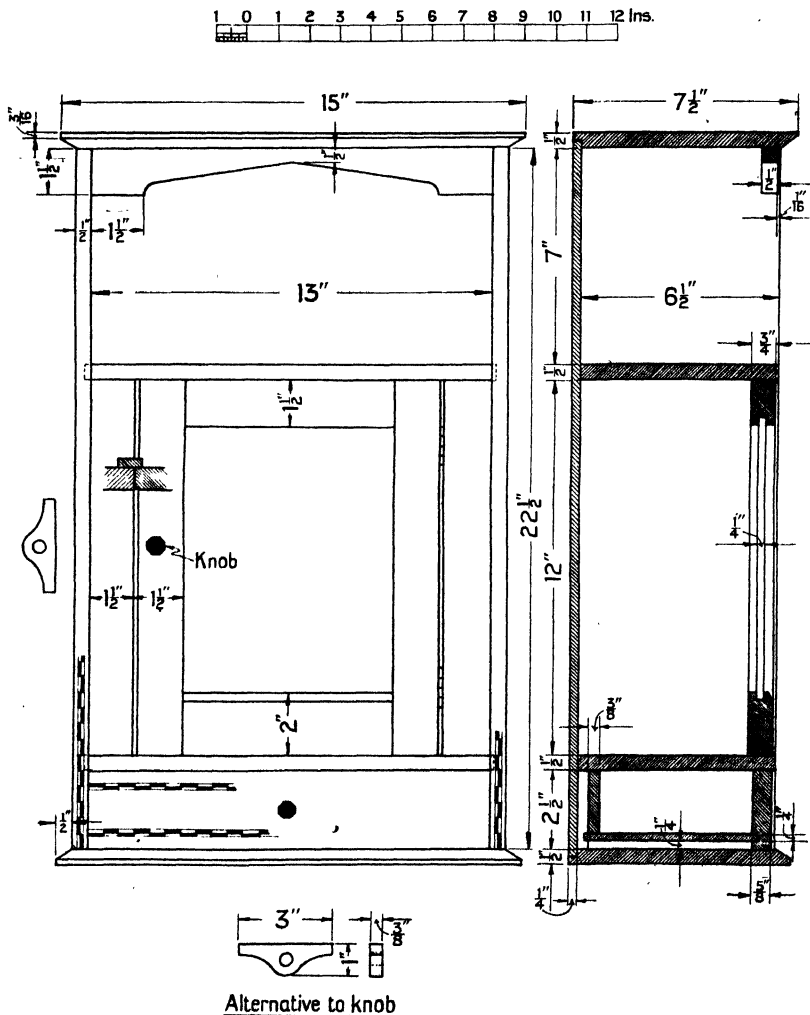

MEDICINE CHEST AND FIRST AID CABINET

The door should be made first and at the back of it should be screwed a rack to hold scissors, tweezers, thermometer, and first aid book. A $\frac{1}{8}$ in. bead is worked on each edge to break the line

where it meets the pilasters. A ball catch should be fitted and, if poisons are to be kept, a lock also.

The top and bottom may be screwed to the sides into which the shelves are housed or the sides may be dovetailed to the top and bottom and the projecting mouldings omitted.

Instead of an ordinary drawer one with a fall-down front, like that of a music drawer, can be fitted or, more simply, a fall-down panel hinged at its lower edge could be substituted.

The pilasters and spandrel are glued and pinned into position.

Small Medicine Cabinet.

CARCASE	DOOR
2 pieces 13 in. \times 7 in. \times $\frac{5}{8}$ in.	2 pieces 11 in. \times $1\frac{1}{2}$ in. \times $\frac{7}{8}$ in.
1 piece 10 in. \times 7 in. \times $\frac{5}{8}$ in.	1 piece 10 in. \times $1\frac{3}{4}$ in. \times $\frac{7}{8}$ in.
2 pieces 10 in. \times $1\frac{1}{2}$ in. \times $\frac{5}{8}$ in.	1 piece 10 in. \times $1\frac{1}{2}$ in. \times $\frac{7}{8}$ in.
1 piece $11\frac{1}{2}$ in. \times $7\frac{1}{2}$ in. \times $\frac{5}{8}$ in.	
1 piece 13 in. \times $10\frac{1}{4}$ in. \times 5 mm. ply.	

It is usually better to make the door first so that if a mistake is made the carcass can be made to fit without wasting material.

The shelf is stop-housed into the side and the top rails lap-dove-tailed into the top ends.

Before gluing up the carcass, the top rails must be drilled and countersunk from underneath to take the screws for the top. The sides must also be rebated for the plywood back.

The moulded edge of the top should be worked with a cutting gauge and moulding plane. A shaped piece of softwood will be required for glasspapering.

If a shelf is needed, it can be fitted loose on two bearers screwed to the sides. It can then be moved if necessary.

Newspaper Rack. Another type-design—

2 pieces	18 $\frac{3}{4}$ in. \times	8 $\frac{7}{8}$ in. \times	$\frac{1}{2}$ in.
2	„	16 $\frac{1}{4}$ in. \times	6 $\frac{3}{8}$ in. \times
1 piece	18 $\frac{3}{4}$ in. \times	6 $\frac{3}{8}$ in. \times	$\frac{1}{2}$ in.
„	18 in. \times	11 $\frac{1}{2}$ in. \times	$\frac{3}{8}$ in. or 5 m.m. plywood.

The rebate and butt joints are pinned with headless panel pins and glued under pressure. The housing for the partition may be fitted dry.

Framed Newspaper and Magazine Rack. The frames should be made first and the mortices for the end rails cut in the corner posts

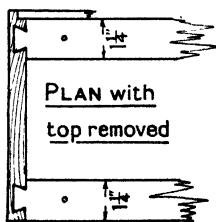
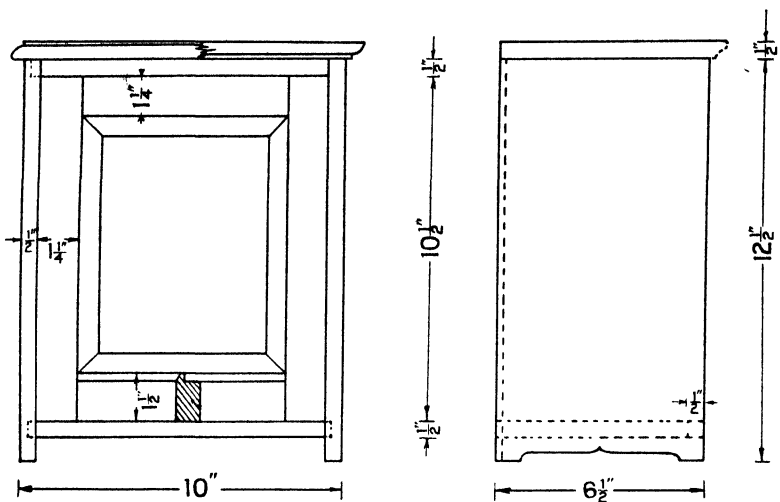

SMALL MEDICINE OR BATH-ROOM CABINET

PLAN with top removed

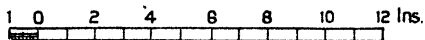
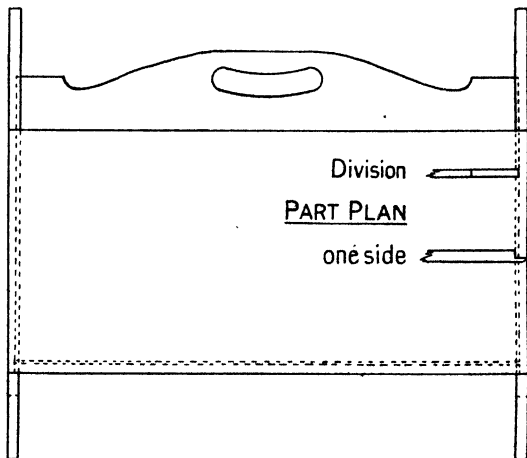
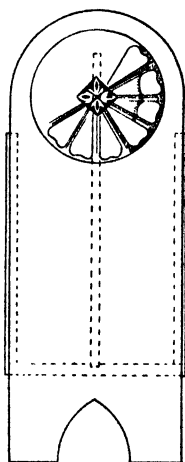

NEWSPAPER RACK

before gluing up. The end rails and side rails have their tenons mitred in the corner posts.

The handle frame is fitted last of all, unless the floor pieces are fastened by glue blocks underneath. When this is the case, plywood can be used for the floor pieces which can be left till last. They should be temporarily fastened with fine panel pins with the heads

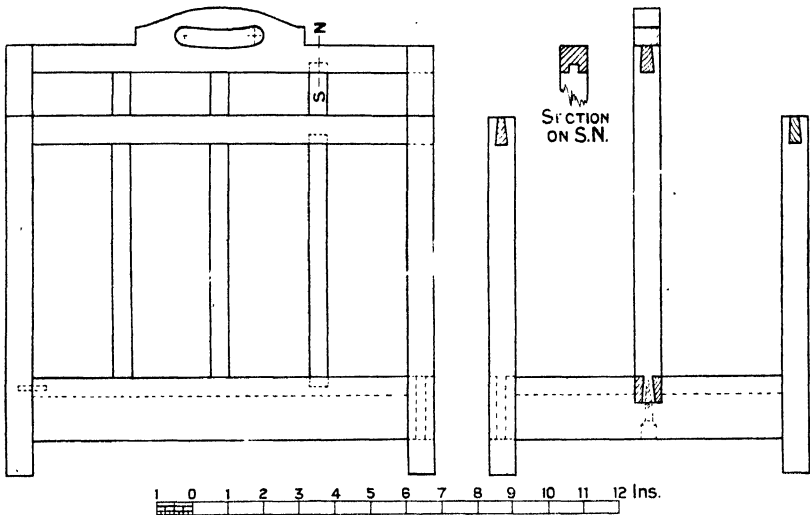

NEWSPAPER RACK

left projecting until the glue blocks have set, when they can be pulled out.

If the floors are made of solid wood and dowelled, as suggested in the drawing, they must be fixed before the central handle frame is finally glued and screwed into position.

Cake Stand—

SIZES

- 1 piece 10 in. \times 2 $\frac{3}{8}$ in. \times 1 $\frac{1}{8}$ in.
- 2 pieces 11 in. \times 1 $\frac{5}{8}$ in. \times $\frac{5}{8}$ in.
- 2 „ 9 $\frac{1}{2}$ in. sq. \times $\frac{1}{2}$ in.

The construction is very similar to that of the occasional table, and the pattern admits of many interesting departures.

If the grain of the top shelf is made to run diagonally, a supporting bracket is unnecessary.

The notches for the shelves are cut $\frac{1}{2}$ in. deep into the upright. The shelves may be dished or a bead planted round the edge.

Table Cake Stand. This will carry two 9 in. plates and fold up when not in use. The octagonal trays are made of 5 m.m. oak plywood with a grooved rim $\frac{1}{2}$ in. \times $\frac{1}{4}$ in. The uprights and handle are made of $\frac{1}{2}$ in. oak. Four 1 in. No. 7 roundhead brass screws and two

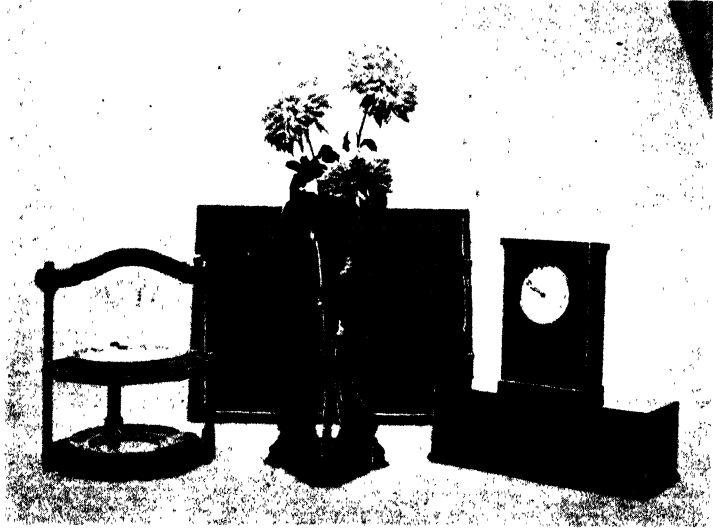

BOYS' WORK

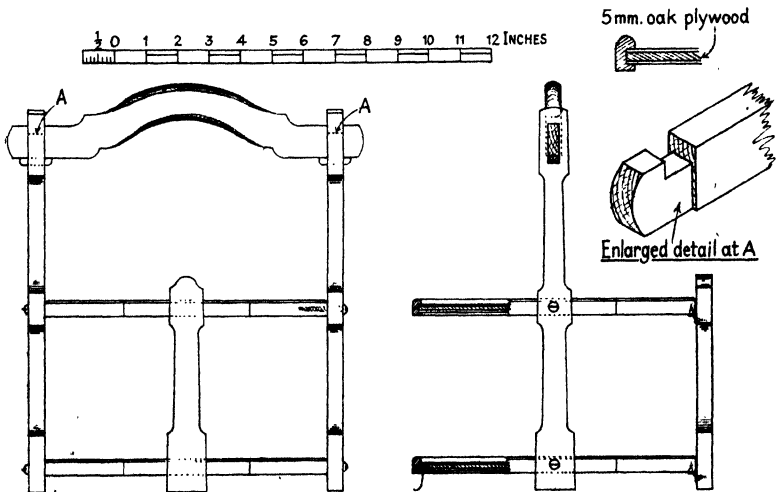
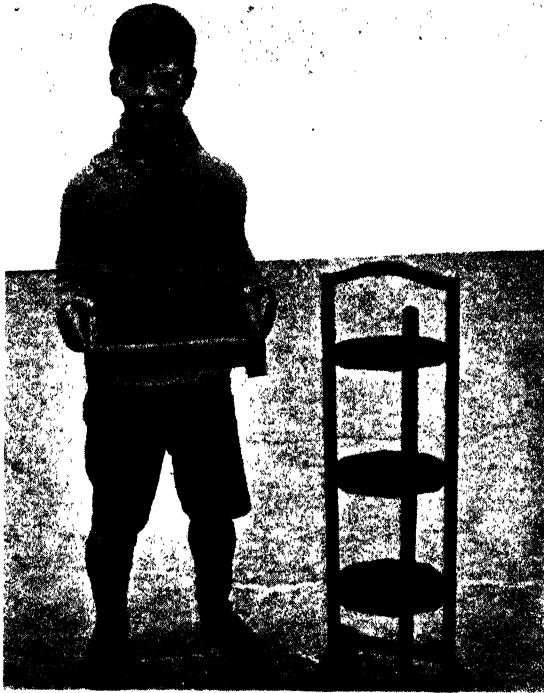

TABLE CAKE STAND

1 in. brass butt hinges will be required; the metal foot opposite the hinged support can be made from a piece of sheet brass, $1\frac{1}{2}$ in. \times 1 in. A simple method of preparing the rim is as follows: Shoot the edge of a $\frac{1}{2}$ in. oak board which should be long enough



FOOTSTOOL, CAKESTAND, AND
CRAFTSMAN

for one or both trays. On this edge plough the groove $\frac{3}{16}$ in. wide \times $\frac{1}{8}$ in. deep and $\frac{3}{16}$ in. from the face side. With a $\frac{1}{4}$ in. bead plane, work the bead on the face side and smooth with glasspaper. Set the marking gauge to the width of the bead plus the quirk, and gauge on opposite side of board. Saw bead off, clear of quirk, plane to quirk and gauge line on opposite side; the rim will then be complete. To mitre, a suitably shaped block can be temporarily fixed to the mitre shooting board. The plywood for the trays should be flat, and if the rim is made a holding fit, glue will be sufficient to secure it.

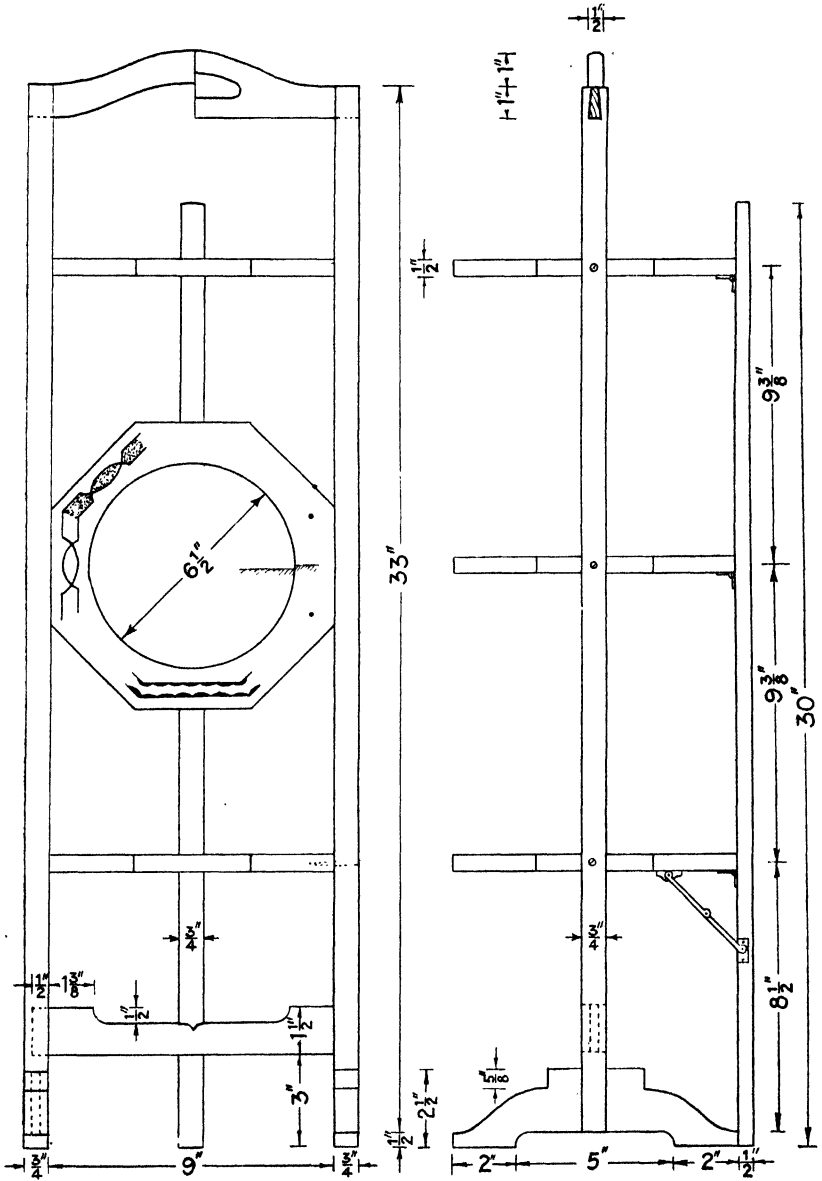

THREE-TIER CAKE STAND

Cake Stand—

2 pieces 33 in. × 1 in. × 1 in.	3 pieces 9½ in. × 9½ in. × ½ in.
1 piece 30½ in. × 1 in. × ¾ in.	2 pieces 11 in. × 2¾ in. × ¾ in.
2 pieces 11 in. × 3 in. × 1 in.	

There are few constructive difficulties. First, make the posts and feet and fork them together. Set out and make the rail mortises and the handle dovetails. Clean off the uprights and feet and glue together.

Make the handle and bottom rail joints, shape these members and glue the frame up square and out of winding.

The trays may be square, circular, or any regular polygon in shape, and may be dished or rimmed with a light bead glued and pinned into position. They are pivoted with R.H. brass screws whose shanks fit loosely into the uprights.

To make the structure rigid when in use, a hinged metal elbow can be used, or a simple bracket ¾ in. thick may be hinged to the link bar. The trays are hinged to this bar with strong strap or backflap hinges.

Alternative treatments are illustrated.

CHAPTER XX

EQUIPMENT

Introduction. As economy is usually important in equipping a centre, it is better to have fewer tools of quality than an abundance of an inferior grade. The importance of good tools kept in the best of condition cannot be over estimated; they are almost a guarantee of good work in themselves.

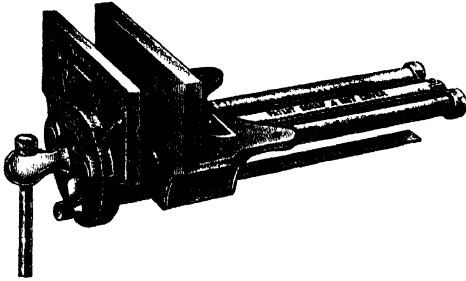

SPRING GRIP VICE

Tools should be easy of access and, if centrally placed, are easy to put away and check at the end of each lesson. Provision should be made for storing, under cover, all tools during the school holidays. Before

being so stored all edge tools, rules, squares, etc., should be well greased.

Benches should be heavy and rigid, well constructed of sound and seasoned timber. The top should be of hardwood with a "well" about $1\frac{1}{2}$ in. deep. The vice should be beyond suspicion—it should open from 8 in. to 10 in., and have a spring grip. The "Parkinson Perfect" or "Record" are hard-wearing accurate types. Underneath there should be a cupboard for holding the routine tools, some in a rack on the door.

Benches are of all types from single to sextuple. The quadruple is probably the best because it is rigid and heavy, has plenty of tool space in the well, and has ample top area for assembling large work and for working large pieces of wood.

The ordinary bench stop is rarely satisfactory, but the following "gadget" if adopted prevents damage to tools, loss of time and temper. A trench $\frac{3}{8}$ in. or $\frac{1}{2}$ in. deep, tapering from 1 in. in width at the well end to $\frac{3}{4}$ in. at the bench edge should be worked in the bench top. A piece of hardwood $\frac{3}{4}$ in. to 1 in. thick is fitted and driven into the trench the full width of the bench plank. This device eliminates damage to planes, can be removed when required,

is easily replaced, and is much better than the usual type when broad boards are to be planed.

Individual Bench Tools

Item

- (1) 1 Jack Plane; technical pattern, sunk handle; $1\frac{3}{4}$ in. blade.
- (2) 1 Tenon Saw; 8 in. blade, brass back.
- (3) 1 Try Square; 6 in.
- (4) 1 Marking Gauge; boys' single, graduated stem.
- (5) 3 Chisels. 1 in. and $\frac{1}{2}$ in. bevel-edge firmer and $\frac{1}{4}$ in. firmer.
- (6) 1 File. 8 in. Cabinet (optional).
- (7) 1 Light Striking Knife.
- (8) 1 Steel Rule 12 in., smallest graduation = $\frac{1}{16}$ in.
- (9) 1 Bench Hook.
- (10) 1 Chiselling or paring board.
- (11) 1 Hand-brush.

General Tools

Quantity	Description
2	Saws, Half-rip pitch 5. 24 in.
2	Hand " 7. 24 in.
2	Cross-cut " 8. 22 in.
2	Panel " 11. 22 in.
2	Bow " 10 in.
4	Coping (Disston patt.)
1	Pad or Keyhole.
1	Compass, detachable blades.
1	Fret-saw frame.
1	Metal piercing.
1	Hack, frame adjustable for blades 8 in. to 12 in.
6	Sharpening Slips.
1	Scratch stock, assorted cutters.
1 pair each	Snips, tinman's, 8 in. or 10 in. straight or curved.
1	Shooting board, mitre.
4	" " end. Should not be less than 18 in.

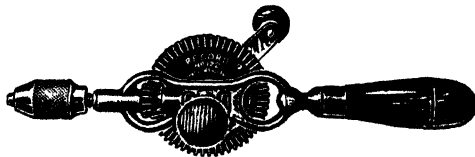

HAND DRILL

- 1 Grindstone with two handles, trough and holder complete.
- 1 Hand or Breast drill with drills from $\frac{1}{16}$ in. to $\frac{1}{4}$ in.
- 1 Set of jewellers diamond pointed drills.
- 6 Holdfasts, assorted sizes.

General Tools—(contd.)

Quantity	Description
1	Metal-work Vice 3 in. jaws.
1	Diamond or wheel glass-cutter.
1	Long woodwork bench, about 18 in. high, for sawing and boring.
2	Black Boards.

N.B. The number of mortise gauges, chisels and mallets must be suitably increased if the disciplinary work is to be taken as class work.

The amount of drawing equipment will depend on whether the drawing is done in school or in the centre.

Auxiliary Tools (40 centre)

Quantity	Description
1	Axe, joiners. 2½ lb.
4	Braces, joiner's plain, ball-bearing head, and alligator jaws.
1	" " ratchet " " " "



"T" BAR CRAMP

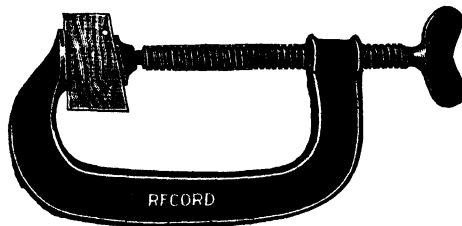

"G" CRAMP

2 each	Bits; centre, ½ in., ⅝ in., ¾ in., 1 in., 1¼ in., and 1½ in.
2 "	" shell or spoon ⅝ in. and ⅞ in.
2 "	" Rose and snail or Stanley pattern countersink.
1 "	" Forstner, ⅜ in., ⅝ in., ¾ in., 7⁄8 in., and 1¼ in.
2 "	" twist (Irwin) ¼, ⅜, and ½ in.
2 "	" dowel (Russel Jennings) ¼, ⅝, and ¾ in.
1	" turn-screw plain, round blade ½ in.
6	Bradawls, assorted.
4	Bevels sliding, 7½ in.
1 pair each	Cramps T bar 30 in., 36 in., 48 in., and 54 in.
1 " "	" " 20 to 24 in.
2 pairs each	Cramp heads for 2 in. × 1 in. wooden bar.
2 " "	" G, swivel end, 6 in. and 8 in.

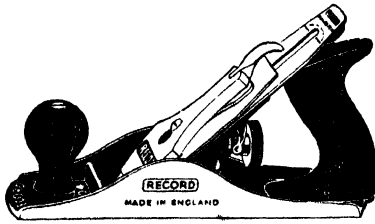

SMOOTHER

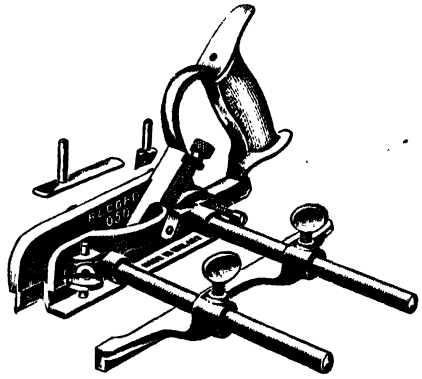

LIGHT COMBINATION PLANE

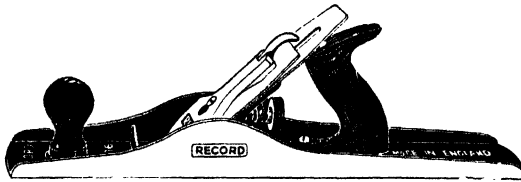

JOINTER

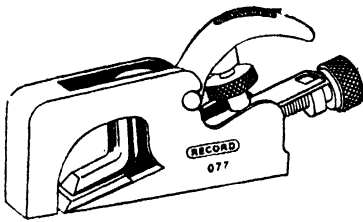

BULL NOSE

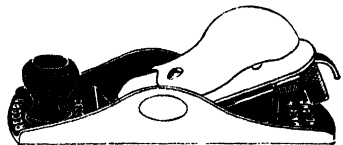

BLOCK PLANE

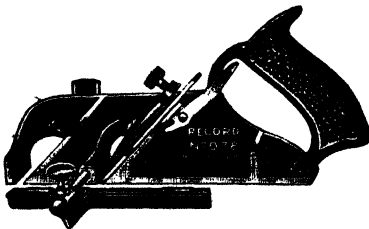

FILLISTER AND/OR REBATE PLANE

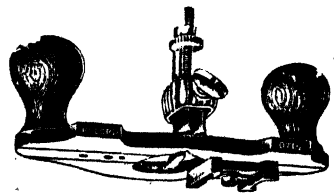

ROUTER

Auxiliary Tools (40 centre)—(contd.)

Quantity	Description
6 each	Chisels firmer, $\frac{1}{8}$, $\frac{3}{16}$, $\frac{1}{4}$, and $\frac{3}{8}$ in.
2 "	" mortise, $\frac{3}{16}$, $\frac{5}{16}$, and $\frac{3}{8}$ in.
6	" " $\frac{1}{4}$ in.
1	" cold metal, 6 in. \times $\frac{1}{2}$ in.
6	Compasses, wing 6 in.
12	Cork Rubbers.
1	Draw Knife, 6 in. Box handles.
1	Disc washer-cutter—to cut up to 10 in. disc.
2 each	Gouges scribing $\frac{1}{2}$ and $\frac{3}{4}$ in.
" "	" firmer, $\frac{3}{8}$, $\frac{1}{2}$, $\frac{3}{4}$, and 1 in.
" "	" carving, A, B, and C curves, assorted sizes.



ADJUSTABLE SPOKESHAVE



HANDLED SCRAPER



CABINET SCRAPER

6	Gauges, cutting, Beechwood, Brass-plated.
6	" mortise, thumbscrew action.
	Extra M.G. with fixed spurs may be made from marking gauges.
6	Files Cabinet half-round 6 in.
2	" " " " 10 in.
1 each	" Rat tail, 8 and 10 in.
2	" triangular, double ended saw.
2	Glue Kettles, 2 pints.
2	" Brushes, circular, metal bound.
12	Hammers, Warrington pattern, size Nos. 1 and 2.
1	" light ball paned.
6	Handscrews, Cabinet Makers, 10 and 14 in.
12	Mallets Joiner's Beech, 4 in.
4	Carver's mallets.
1	Oil can.
1 each	" Stones, 8 in. \times 2 in. \times 1 in. India fine and Washita.
3 pairs	Pincers Lancashire pattern, 6 in.
2 pairs each	Pliers flat and round-nose and wire-cutting.
1 pair	" solid steel cutting nippers for iron wire 7 in.
4	Punches, nail, cupped two sizes.
1	" centre.
4	Planes, Trying, 22 in. \times 2 $\frac{1}{2}$ in. for use with shooting boards.

Auxiliary Tools (40 centre)— *contd.*)

<i>Quantity</i>	<i>Description</i>
1	Plane, "Record" jointer 18 in. × 2 $\frac{3}{8}$ in. iron.
4	Planes ,, smooth, 8 in. × 1 $\frac{1}{4}$ in.
1	Plane toothing 2 in. irons, medium and fine.
1	,, "Record" light combination for plough or dado, beading, matching, and rebating.
1 each	Planes Ovolo moulding $\frac{1}{4}$ in. and $\frac{3}{4}$ in. Beech.
1	Plane Bullnose 4 in. × 1 in.
1	,, Block 6 in. × 1 $\frac{3}{8}$ in screw feed.
1	,, shoulder $\frac{3}{4}$ in.
1	,, Fillister
1 pair each	Planes Hollow and round Nos. 4, 6, and 8.
1	Plane Chamfer, beech.
2	Planes "Record" router, closed throat, 3 cutters.
1 each	Try squares 9 in. and 12 in.
4	Scrapers, steel, handled.
4	,, ,, assorted shapes.
2 each	,, sharpeners.
2 each	Screwdrivers 3, 6, and 8 in.
1	,, short, cabinet, crutch handle 3 in.
1	Spokeshave, chamfer.
2 each	,, "Record" adjustable No. 0151 and R 0151.
2	,, Boxwood round sole 2 in. cutters.
2	Stanley 200 cutter and chisel grinder.

APPENDIX I

BIBLIOGRAPHY

DESIGN

<i>Title</i>	<i>Author</i>	<i>Publisher</i>
<i>Catalogue of English Furniture.</i> Vols. 1 and 2		Victoria & Albert Museum
<i>A Picture Book of Chests</i>		
" " " <i>Chairs</i>		Victoria & Albert Museum
" " " <i>Tables</i>		
<i>Lettering Sheets 1 and 2</i> (Panel of Hoptonwood Stone)	Gill	Victoria & Albert Museum
<i>Historic Ornament</i>	Glazier	Batsford
<i>Drawing, Design, and Craftwork</i>	Glass	Batsford
<i>Industrial Arts Design</i>	Varnum	Batsford
<i>Everyday Art at School and Home</i>	Sawer	Batsford
<i>Design as Applied to Arts & Crafts</i>	Smith	Pitman
<i>Simple Art Applied to Handwork.</i> Vols. 1 and 2	Rankin & Brown	Pitman
<i>First Book of Pattern Design</i>	Hargreaves	Black
<i>Second " " "</i>	Higgins	Black
<i>A Handbook of Elementary Design</i>	Sleigh	Pitman
<i>Design and Handicraft</i>	Horth	Pitman
<i>Elements of Design</i>	Dickson	Pitman

LETTERING

<i>Title</i>	<i>Author</i>	<i>Publisher</i>
<i>Modern Lettering from A to Z</i>	Wade	Pitman
<i>Manuscript and Inscription Letters</i>	Johnston	Pitman
<i>"Art for All" Drawing Series</i> <i>Design. (I) Lettering</i>	Littlejohns	Pitman
<i>A Book of Lettering</i>	Robertson & Field	Black
<i>Lettering</i>	Payne	Batsford

GENERAL READING

<i>Title</i>	<i>Author</i>	<i>Publisher</i>
<i>Handwork as an Educational</i> <i>Medium</i>	Ballard	Allen & Unwin
<i>The Wheelwright's Shop</i> <i>William Morris</i>	Sturt Clutton Brock	Cambridge U.P. Thornton Butterworth
<i>The Nature of Gothic</i> <i>The Modern Schools Handbook</i>	Ruskin	Allen & Unwin Gollancz

GENERAL READING—(contd.)

<i>Title</i>	<i>Author</i>	<i>Publisher</i>
<i>The Carpenters' Toolchest</i>	Hebben	Routledge
<i>Psycho-Analysis for Normal People</i>	Coster	Oxford U.P.
<i>On Education</i>	Russell	Allen & Unwin
<i>Talks to Parents and Teachers</i>	Lane	Allen & Unwin
<i>The Children We Teach</i>	Isaacs	University of London Press
<i>How to Calculate a Correlation</i>	Thompson	Harrap
<i>Suggestions for Teachers</i>		H.M. Stationery Office
<i>Craftsmen All—An Anthology</i>		Dryad
<i>Romance of Craft. Books 1-4</i>		Nelson
<i>Hand and Eye Training</i>	Holman	Pitman
<i>Proper Studies</i>	Huxley	Chatto & Windus
Various Reports issued by H.M. Stationery Office—		
1. Education of the Adolescent.		
2. Primary School.		
3. Psychological Tests of Educative Capacity.		
<i>The Age of Machinery</i>		Blackie
<i>The Book of School Handwork.</i>		
6 Vols.		Caxton
<i>A Classification of Vocational Tests of Dexterity</i>	Weiss & Pear	H.M.S.O.
<i>The Nervous Temperament</i>	Culpin & Smith	H.M.S.O.
<i>The Science of Marking</i>	Thomas	Murray
<i>History of Manual and Industrial Education to 1870</i>	Bennet	Batsford

WOODWORK

<i>Title</i>	<i>Author</i>	<i>Publisher</i>
<i>Woodwork Design</i>	Arnold	Pitman
<i>The Art of Cabinet Making</i>	Denning	Pitman
<i>The Furniture Styles</i>	Binstead	Pitman
<i>Handicraft of Wood-Carving</i>	Jackson	Pitman
<i>Art of Woodworking and Furniture Making</i>	Gregory	Dryad
<i>Constructive Woodwork for Schools</i>	Gregory	Dryad
<i>Handicraft in Wood and Metal</i>	Hooper & Shirley	Batsford
<i>Furniture for Small Houses</i>	Wells	Batsford
<i>Principles of Educational Handwork</i>	Binns & Marsden	Dent
"The Woodworker" Series		
<i>Staining and Polishing</i>		Evans Bros.
<i>Woodwork Joints</i>		Evans Bros.
<i>Details of Cabinet Construction</i>		Evans Bros.

WOODWORK—(contd.)

<i>Title</i>	<i>Author</i>	<i>Publisher</i>
<i>Cabinet Making</i>	Keeble	Longmans
<i>Woodwork for Schools on Scientific Lines</i>	Baily & Pollitt	Murray
<i>Old English Furniture : The Oak Period</i>	Garside	Batsford
<i>Modern Cabinet-Work, Furniture and Fitments</i>	Wells & Hooper	Batsford
<i>Problems in Furniture Making</i>	Crawshaw	Batsford
<i>A Woodwork Bench Notebook</i>	Haywood	Cassell
<i>Furniture Inlaying</i>	Frost & Fullerton	Batsford
<i>Joints, and How they are Made</i>	Klenke	Batsford
<i>Home Upholstery</i>	Dane	Pitman
<i>Plywood</i>	Little	Pitman
<i>Wood-carving Design and Workmanship</i>	Jack	Pitman
<i>Uses of Home-grown Timber</i> (Forest Products Research)		H.M.S.O.

DRAWING

<i>Title</i>	<i>Author</i>	<i>Publisher</i>
<i>Practical Geometry and Graphics</i>	Low	Longmans
<i>P. P. and Solid Geometry</i>	Morris & Husband	Longmans
<i>British Standard Drawing Office Practice</i>		Crosby Lockwood
<i>Mechanical Drawing</i>	Lay	Pitman
<i>Elementary Practical Drawing</i>	Reeder	Pitman

APPENDIX II

GLOSSARY OF TECHNICAL TERMS

- Alburnum.** The botanical term for sapwood.
- Angle Bead.** A bead having a quirk on adjacent sides, a return bead.
- Annual Rings.** The concentric rings shown in the cross-section of a tree.
- Arris.** The edge or line in which two plane surfaces meet.
- Astragal.** A semicircular moulding which projects from the surface. When flush with the surface, it is called a bead.
- Back Flap.** A hinge used in fixing folding shutters and table leaves.
- Badger.** A wide rebate plane with a movable fence.
- Barefaced Tenon.** One with a shoulder on one side only.
- Basil.** The grinding bevel of any cutting tool.
- Batten.** Converted timber less than 9 in. \times 3 in. and more than 4 in. \times 1 $\frac{1}{4}$ in.; also horizontal ledges in "batten" doors.
- Baulk.** Timber roughly squared with an axe or adze.
- Bead.** A small semicircular moulding having a quirk or sinking. When sunk and without quirk is known as a reed. When it projects beyond the surface is called a cock bead.
- Bench Screw.** A wooden or metal vice fixed on the side or end of the bench.
- Bevel.** An angle other than 90°; also a tool with an adjustable blade called a slide bevel.
- Birdsmouth.** An internal angle cut on the end of a piece of timber to fit the salient angle of a cross-piece of timber.
- Box Tenon.** An angle tenon in a corner post.
- Brace.** A member introduced into a rectangular frame to stiffen or strengthen it; also a tool with a cranked handle used to hold boring tools or bits.
- Bracket.** A triangular frame to support a shelf.
- Bullnose.** A small metal rebate plane.
- Butt Hinges.** Hinges with square or butt ends to be sunk into the wood.
- Butt Joint.** A joint square to the length, the ends abutting.
- Capping.** A mould on the top of a screen or gate.
- Cast.** Wind or twist, usually applied to distortion in length.
- Caul.** A piece of wood or zinc, used in veneering.
- Chamfer.** A plane surface inclined to two right-angled surfaces.
- Cheek.** The side of a mortise; also the portion cut away to form a tenon.
- Clamp.** A strip framed across the ends and flush with larger piece to prevent warping.
- Cleat.** A wooden cramp; also a chock or bearing piece.
- Compass Plane.** A plane with circular sole.
- Compass Saw.** A small handsaw with a narrow tapering blade.
- Cross Tongue.** A thin strip cut square across the grain.
- Deal.** Common term for all fir timber—also a market size of timber 3 in. \times 9 in., or 3 in. \times 10 in., called a "deal."

Double Tenons. Two or more tenons side by side.

Dovetail Key. A piece of wood tapering in length and undercut at the edges, inserted across the grain to prevent warping.

Dowel Plate. A steel plate with suitable holes drilled in, by which dowels are made.

Drop Handle. A drawer or door handle that drops down when not in use.

Dry Rot. A fungus which attacks felled timber—induced by lack of ventilation and dampness.

Duramen. The heartwood of timber trees.

Escutcheon. A metal plate surrounding a keyhole—usually ornamental.

Expansion Bit. A screw bit with one or two movable cutters.

Feather Tongue. A thin slip cut obliquely across the grain.

Fielded Panel. A panel having a bevelled margin

Flush. Level with the surface of the framing.

Flutes. Semicircular grooves in columns or pilasters.

Grooved and Tongued. A form of joining boards together by means of matching planes—one plane working a tongue or one edge which fits a corresponding groove worked by another plane on the opposing edge.

Grooving. Rectangular sinking in the surface of any material.

Hand Screw. A wooden clamp worked by means of a pair of threaded handles.

Hanging Stile. The stile of a door on which the hinges are fixed.

Haunch. The part of a tenon that is left after being reduced in width.

Haunching. The recess (either parallel or tapered) cut in a stile or leg to receive the haunch.

Heartwood. Matured wood as distinguished from sap-wood.

Horn. A projection on the ends of a frame.

Housing. Sinking the end of one piece completely into another without reducing its thickness.

Iron. The cutter of a machine or hand-tool.

Kerf. A saw-cut.

Live Knot. One that is incorporated with the surrounding wood and will not fall out.

Lock Rail. The rail of a door in which the lock is fixed.

Lying Panel. One with the grain running horizontally.

Medullary Rays. The radiating septa which produce "silver grain" in oaks and beeches.

Mitre. The intersection of two pieces at any angle other than a right angle.

Mitre Box. A three-sided box with suitable saw-cuts in its sides in which large mouldings are steadied whilst being sawn.

Mitre Clamp. A clamp mitred at one or both ends at an angle of 45°.

Mitre Cut. For a similar purpose to the above, having a rebate on one side to take small work.

Mitre Dovetail. A secret dovetail.

Muntings. The interior vertical divisions of a door or framing.

Newel. A post at the head or foot of a flight of stairs to which the string and handrail are fixed.

Nosing. The semicircular projection to a flat surface.

Notching. A sinking, cut out of a piece of timber equal to the thickness of the piece which crosses it.

Ogee. A moulding, the section of which is made up of two reversed arcs of a circle.

Oilstones. Stones used in conjunction with oil to sharpen edge tools. Natural stones: Washita; Arkansas; Turkey, and Charnley Forest. Artificial: Carborundum, Emery, and India.

Old Woman's Tooth. A router or trenching tool.

Ovolo. Roman section a quarter circle; Grecian section a quarter ellipse.

Pad or Keyhole Saw. A small tapering saw fitted to a handle or pad into which it can be slid when not in use.

Panel. Any surface sunk below its surroundings, usually applied to the thin wide pieces inserted between the members of a framing.

Parting Tool. A vee-shaped gouge, either straight or bent.

Paterae. Small disc ornaments applied to any surface.

Pilaster. A thin rectangular section column, either parallel or tapering.

Pine. The wood of the tree *Pinus Strobus*; commonly applied to the timber of all trees of the order *Pinus*.

Pinned Joint. One in which small wooden pegs or dowels are driven through the mortise and tenon.

Plane. A perfectly flat surface; also a cutting tool with a wide chisel fixed at a constant angle in a block of wood.

Planted. Mouldings inserted as distinct from those "stuck" or worked on the solid.

Plough. An adjustable grooving plane.

Polish (French). Shellac dissolved in methylated spirit.

Quartered Oak. Logs sawn into quarters and then cut radially; the method used in preparing "Wainscot Oak."

Quirk. An interior corner in a moulding.

Racet Brace. One fitted with a cogged stop which enables it to be used in confined spaces (see Brace).

Rebate. Generally called rabbit. A rectangular sinking on the edge of a board or framing.

Rod. A board on which full-size sections of work are made to facilitate the setting out of the material.

Run, to. Term used when a saw deviates from the correct line.

Sap-wood. That portion of a tree through which the sap passes to and fro; immature wood between the heartwood and the bark.

Scale. The ratio or proportion which a drawing bears to the object it represents.

Scrape, to. A method of obtaining a better finish to hardwood after planing by removing extremely thin shavings.

Set. The inclination to the plane of the blade given to the teeth on opposite sides of a saw, so that they cut a kerf wider than the thickness of the saw for easier working.

Set Square. A triangular piece of wood one angle of which is a right angle.

Setting Out. Marking out joints, etc., on prepared stuff; also working drawings on a rod.

Shake. A longitudinal split or cleft in a board.

- Shooting.** Planing the edge or end of a board straight and square.
- Shoulder.** The abutting parts of a mortise and tenon joint.
- Sight Line or Daylight Line.** The interior edge of a frame or opening.
- Silver Grain.** The figure of oak and beech wood caused by the medullary rays or septa cropping out on the surface of the board.
- Sprig.** A brad without a head and round or oval in section.
- Striking Knife.** A tool used for cutting-in shoulder lines, etc.
- Stub Tenon.** One that does not pass through the piece mortised.
- Stuck.** Worked on the solid as opposed to "planted."
- Stuff.** Wood used in joinery.
- Sunk Panel.** Usually applied to the sham panels worked in the solid on newels, pilasters, etc.
- Tang.** That part of a tool in the handle.
- Tenon.** A projection formed on the end of a piece of wood by reducing it in thickness on one or both sides.
- Tongues, Loose.** Thin slips of wood to fit into grooves. Three kinds, viz. feather, cross, and straight.
- Toothing.** Fine grooves or scratches made in the surfaces of pieces of wood that are to be glued together.
- Toothing Plane.** A wooden plane with a notched iron used to tooth veneers and flat surfaces.
- Vee Tool.** See Parting Tool.
- Veiner.** A small U-shaped carving tool.
- Veneer.** Superior woods cut into thin sheets and glued to the surfaces of less valuable woods; used largely in furniture.
- Volute.** A spiral scroll.
- Warping.** Twisting of a board in its width due to unequal shrinking.
- Winding.** Opposite to a "plane" surface, i.e. twisted.
- Wing Compasses.** Having a quadrant stay with thumb-screw attached.
- Wood Screws.** Metal screw-nails with threaded stems, slotted heads, and gimlet points for use in woodwork.
- Working Drawings.** Sections full-size or nearly so.
- Wrought.** Planed up.

APPENDIX III (A)

“THE BEST OF ITS KIND”

Antique Practice. Included by the courtesy of the Director of the Victoria and Albert Museum, South Kensington.

These photographs are reproduced not only for their historical significance, but because the methods of construction, their proportions, simple shapes and decorations are such as the boy can adopt, with or without modification, for his own work.

They exemplify the permanence of good craftwork, and the achievements of tool-learned, if not book-learned, men using only the rudest instruments.

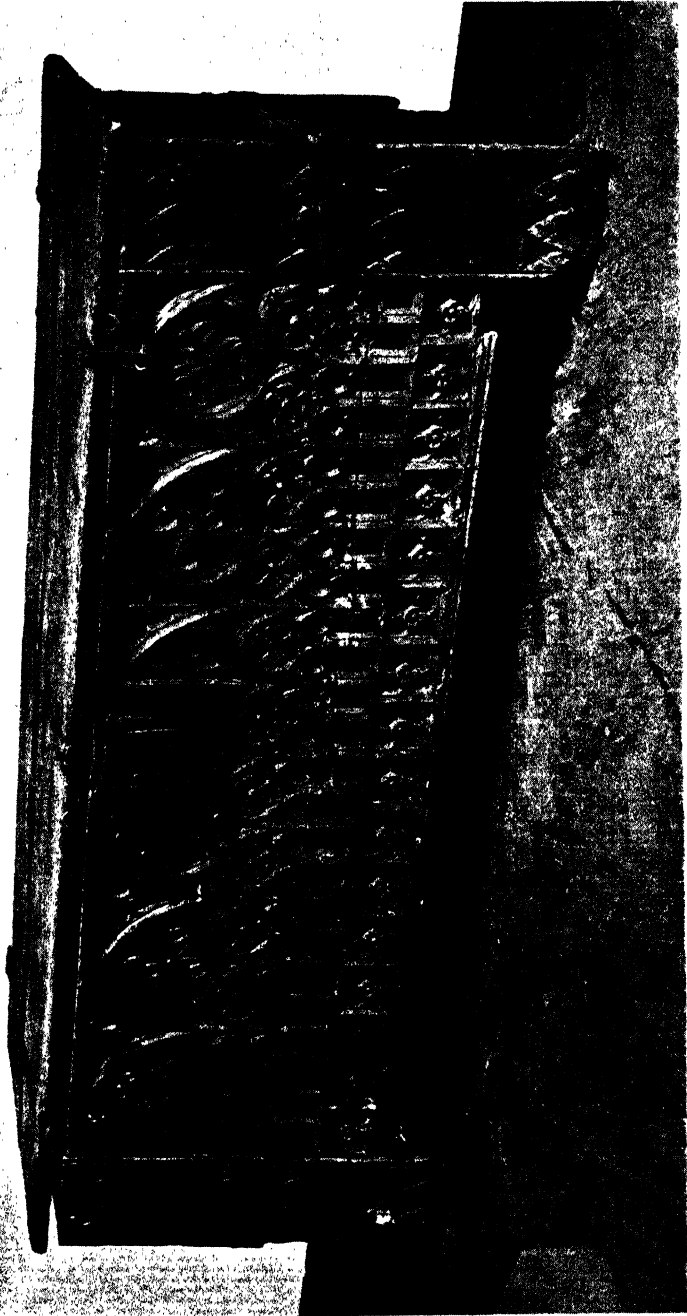

FOURTEENTH CENTURY CARVED OAK CHEST

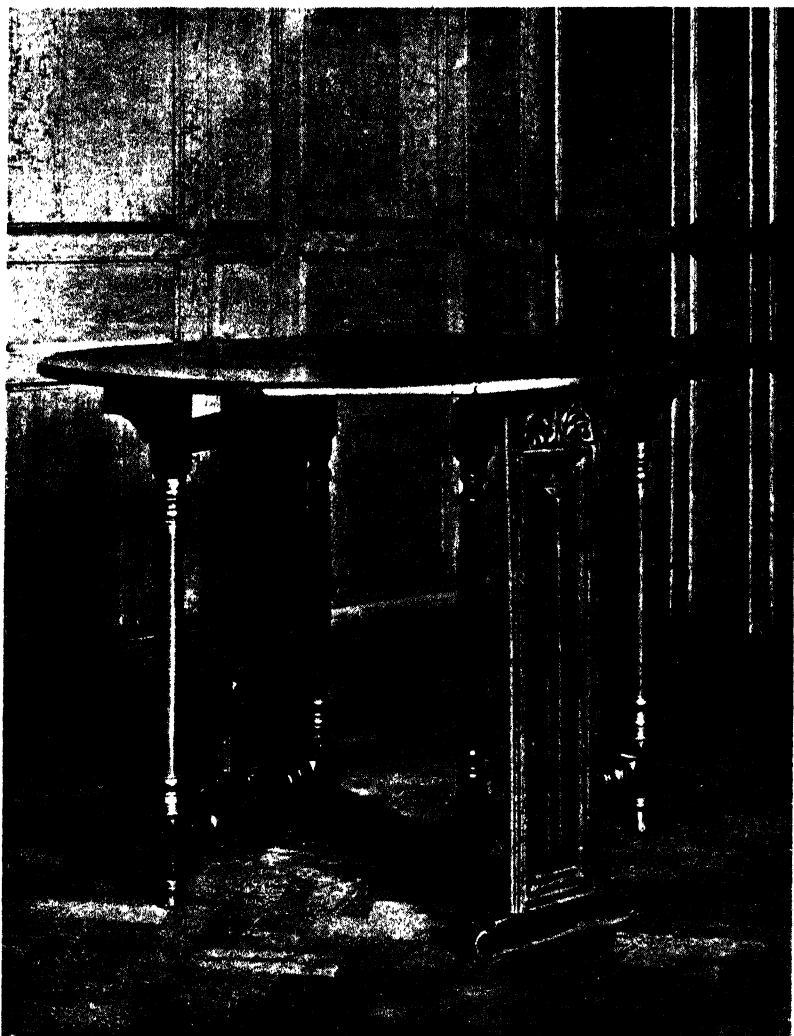

OAK "GATE-LEG" TABLE
Mid-Seventeenth Century



GLASTONBURY CHAIR
Mid-Sixteenth Century



OAK DRAW-TABLE
Sixteenth Century

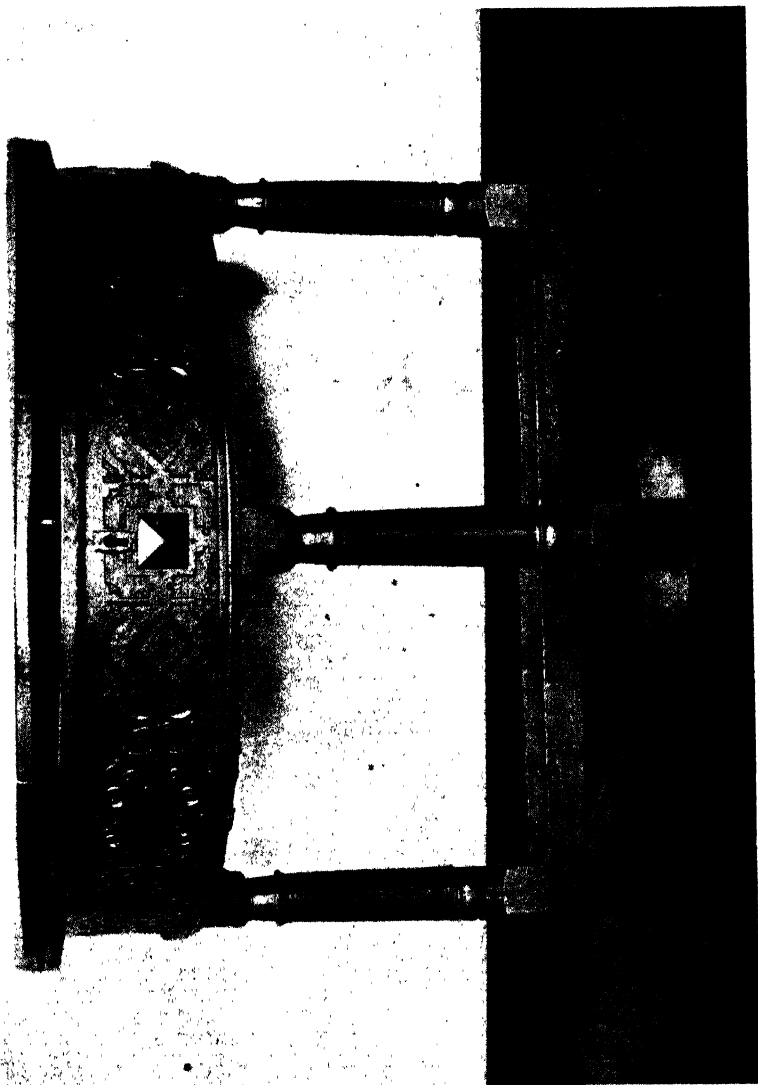

CARVED OAK SIDE-TABLE, WITH FOLDING TOP
Seventeenth Century

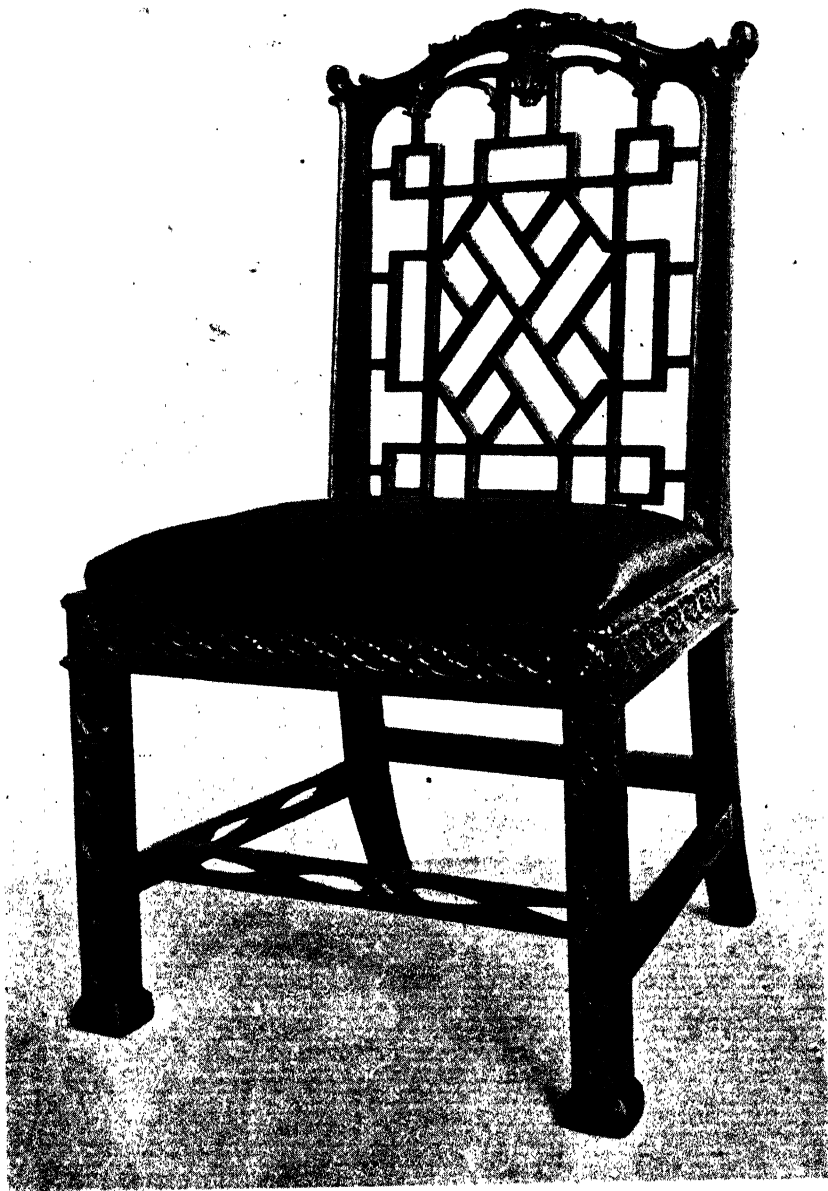

"CHIPPENDALE" MAHOGANY CHAIR
Eighteenth Century

APPENDIX III (B)

Modern Hand-practice. The photographs, included by permission of Peter Waals, Chalford, Gloucestershire, and Gordon Russell, Broadway, Worcestershire, typify the modern tendency in design and construction where every use is made of pleasing proportion, clean, restful lines and the beauty of wood grain.

The illustrations of the work of Robert Thompson, Kilburn, Yorkshire, included by his courtesy, show what is being done to-day along traditional lines. All the work is adze finished.

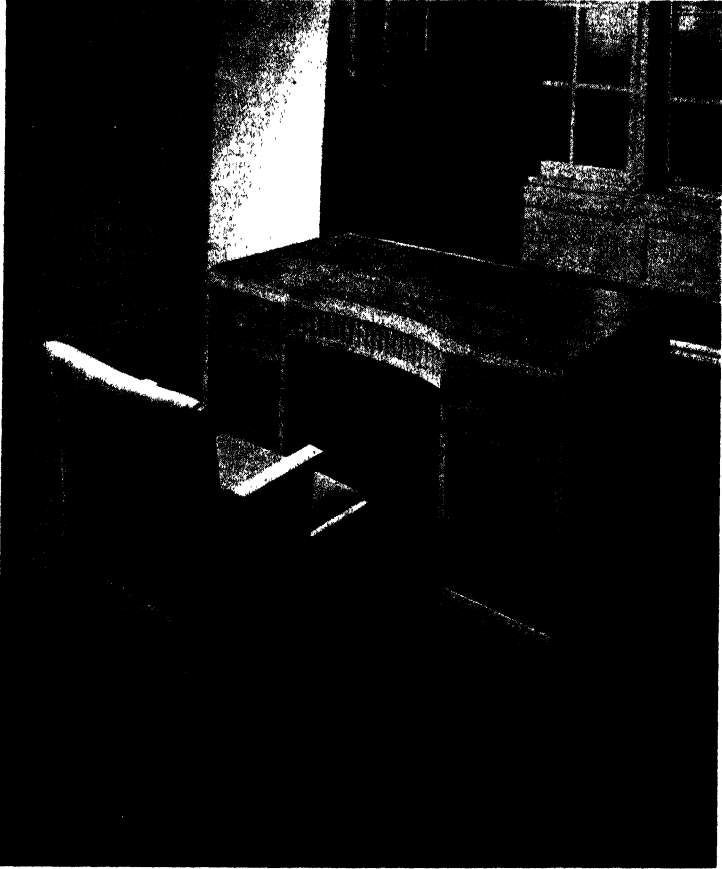

PEDESTAL DESK IN NATURAL WAX-POLISHED WALNUT

Gordon Russell



WALNUT CABINET, VENEERED CHERRY AND
LABURNUM, ON ROSEWOOD STAND

Gordon Russell

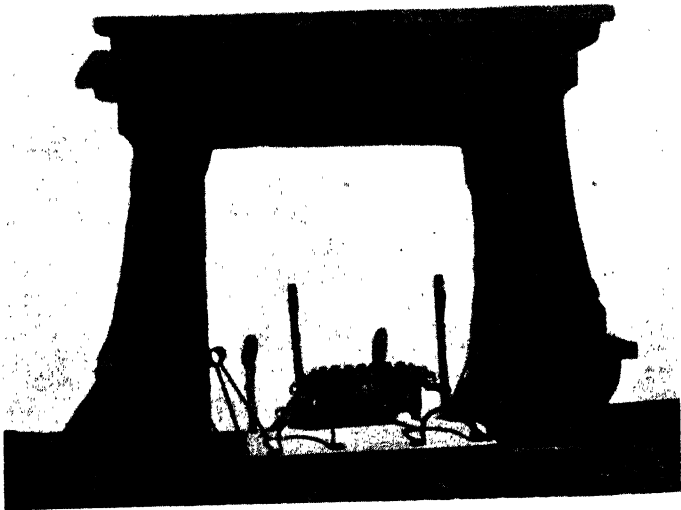

OAK FIREPLACE, WITH SEATS

Robert Thompson

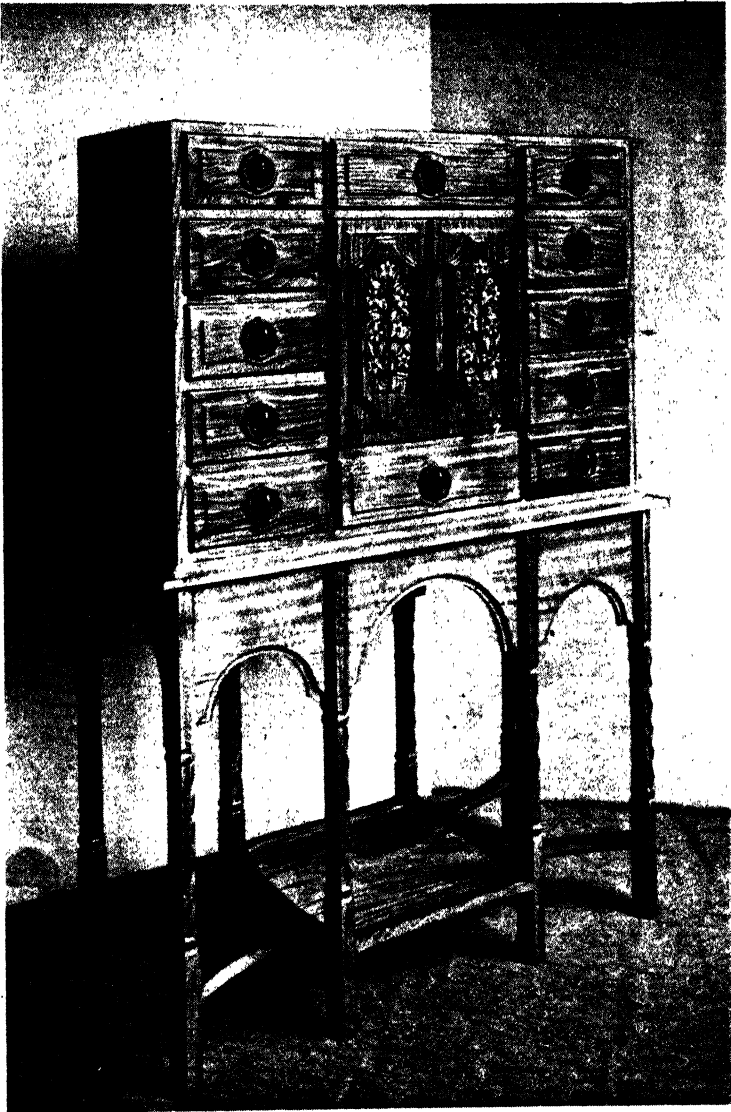

CABINET ON STAND IN WALNUT. INLAID EBONY,
BOX AND LABURNUM. INTERIOR VENEERED
OYSTER WOOD

Gordon Russell

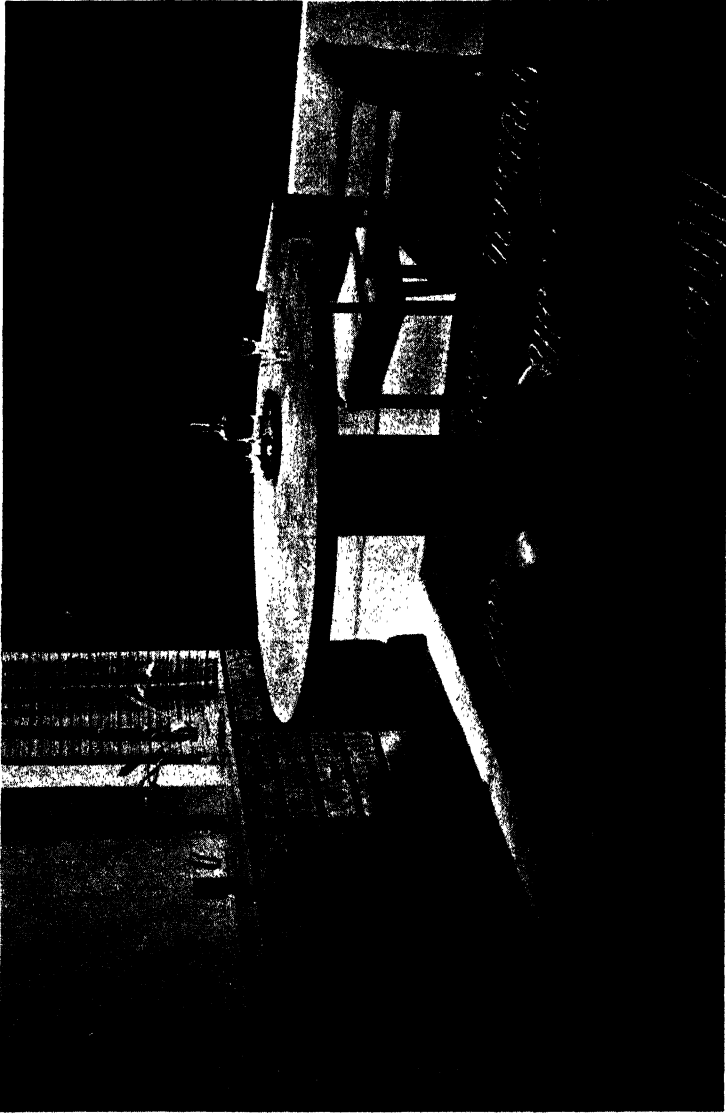

AN INTERIOR
Gordon Russell

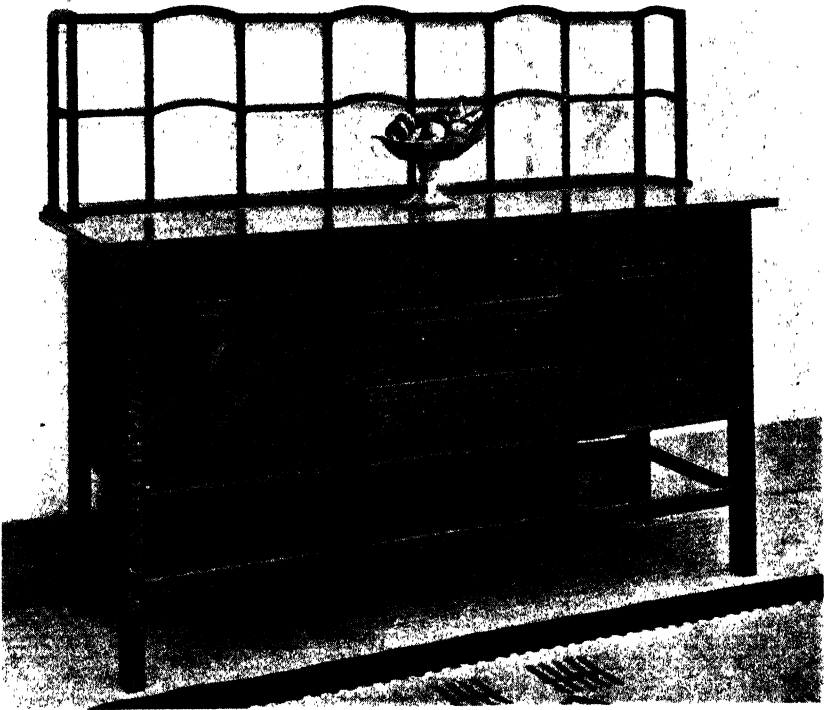

SMALL SIDEBOARD IN ENGLISH OAK AND EBONY

Peter Waals

AN OAK BEDSIDE
CABINET

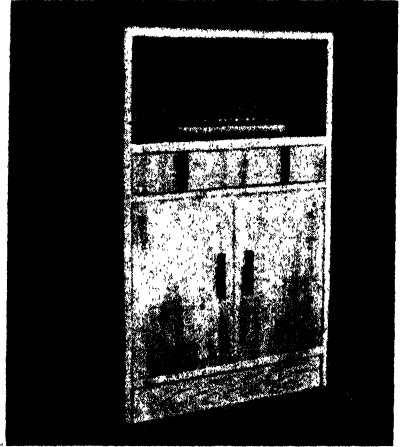

OAK SHAVING MIRROR
—DROP FRONT

*Specimens of work executed by boys attending
advanced classes.*

INDEX

- ABILITY, 6
 —, general school and handwork, 59
 —, outstanding, 10
 Abrasives, 3
 Accuracy, 20, 21, 51, 53, 75
 — and speed, 57
 Adolescence, 10
 Adze, 41
 Aggressiveness, 12
 Aids, 1
 —, teaching, 11
 Aim of handicraft, 1
 — of testing, 51
 Amateur, 2
 — craftsman, 2
 Ambitious shoddy, 6
 Amusements, present day, 2
 Analogy, reasoning by, 17
 Analysis of mistakes, 70
 Angles, 116
 Appeal, the emotional, 15
 Appendages, useless, 7
 Approximate solutions, 119
 Areas, 118
 Arithmetic, practical, 31
 Arrow heads, 35
 Art, 31
 Artisan, 9
 —, better class boys, 52
 Artist, 10
 Attention, 7
 Attitude, teacher's mental and physical,
 16
 Automatism, 61
 Axe, 41
 Axometric projection, 33

 BACKWARD and dull boy, 16
 Bisect a line, to, 116
 Bloom on polish, 46
 Blotter, 89
 Blue prints, 35
 Book ends, 87, 148, 154
 —, record, 37
 — shelves, 163
 — troughs, 98, 101, 161
 Boredom, 13
 Boring, 29
 Boy, the emotional response, 19
 —, feeble minded, 18
 —, the lazy, 16
 —, mentally inert, 17
 —, physically weak, 17
 Boys, tested, 52
 Bridle joint, 113

 Brushes, polish, care of, 46
 Bureau, 168
 Burnisher, use of, 45

 CAKE stands, 217-222
 Calculations, 40
 Cards, instruction, 18, 21, 23, 25, 26, 28,
 30
 Carving, 7
 Casket, oak, 193
 Catalogues, 1
 Category, 70
 Cellulose paint, 46
 Centre of gravity, 119
 Certificate frame, 100-102
 Chiselling, 143
 Change and novelty, 71
 Chart, wall, 37
 Chemicals, 40
 Chess board, 151
 Child, "criminal" 12
 —, "spoiled," 12
 —, study of, 12
 —, unusual, 10
 Children, copyists, 11
 Chiselling, 26-28
 Cigarette box, 152
 Circle, 117
 City and Guilds Institute, 4
 Class teaching faults, 15
 Clothes airer, 158
 Coaching, 22
 Colour, 7
 Communal work, 18
 Comprehension, poor, 17
 Comradeship, 18
 Conclusions, test, 70
 Confidence, 12
 Consciousness, 14
 Contacts, school, 13
 Contests, speed, 12
 Control of class, 15
 —, lack of, 11
 Conventions, geometrical, 18
 Co-operation of child, 15
 Correct use of tools, 22
 Correlation, 5
 Courses, handicraft, 3
 Craft habits, good, 18
 — puzzles, 4
 Creosote, 44
 Critical faculty, 17
 Criticism, children's, 12
 Crumb tray, 85, 150
 Culture, 2

- Curiosity, 12
 Curves, French, 42
 —, on wood, 7
 Cutlery box, 96
 — canteen, 194
- DANGER, 13**
 Deaf boys, 52
 Decoration, 76
 Defects, special, 21
 Definitions, 33
 Demonstration of new process, 20
 — of test, 53
 Designs, 6, 7, 76
 —, advanced, 77
 —, amendments to, 7
 —, boys reaction to, 7
 —, complexity and skill, 62
 —, elaborate, 7
 —, modification of, 7, 33
 Designing, 5
 Dexterity, 9, 20
 —, lack of, 17
 Diagnosis of faults, 21
 Dictatorship, 12
 Differences, intellectual and tempera-
 mental, 11
 Difficulties, teacher's 3
 Dimensions, 34, 35
 Dinner wagon, 167
 Discipleship, 12
 Discipline, 1, 11
 —, too rigid, 12
 Disciplinary joints, 20, 107
 Dislike of teacher and subject, 19
 Displayed instructions, 20
 Doing and listening, 13
 Dovetail halving joint, 110
 Dovetail joints, 92, 113
 Dowel joints, 43
 Drawing, 3, 31
 —, equipment, 34
 —, folio, 35
 —, ink, 35
 —, instruments, 34
 —, lay-out, 34
 —, symbols, 18
 —, tests, 40
 —, the three stages, 33
 Drill, tool, 9, 10, 17, 18, 20, 22
 Drudgery, 20
 Dull and backward boy, 16
 Dyes, 44
- Edge shaping, 143
 Educational rubbish, 4
 Efficiency maximum, 6
 — of articles, 6
 Egotism, teacher's 16
 Electric reading lamp, 156
 Elementary—secondary—comparison,
 61
- Elementary best, cf. secondary school,
 63
 Ellipse, the, 118
 Emotions, undesirable, 12
 Emotional appeal, 15
 Emulation, 12
 Encouragement, 13
 English, the teacher's poor, 16
 Enlarging drawings, 118
 Enthusiasm, 11
 —, lack of, 16
 Environment, 2
 Errors, test, 55
 Exercises, disciplinary, 107
 Exhibits of work, 11
 Experiment, interesting, 51
 Experiments, 9
 "Extras" test, 70
- FEEBLE** minded boys, 18, 52
 Finger-plates, 146
 Finger tips, use of, 21
 Finish, 4, 52, 70, 76
 Finishing, wood, 44
 Fire screens, 207-210
 Flower stand, 152
 Folio for drawings, 35
 Folk tools, 3
 Foot rest, 161
 Forces, rebellious, 15
 Form, fine, 6
 Formula for test marking, 56
 Foul language, 14
 Fractional dimensions, 35
 Frame, certificate, 100
 Frames, mirror, 102-105
 Freedom, 4
 French curves, 42
 French polish, 45
 Freshness, 13
 Fretwork, 7
- GAUGE** for test, 54
 —, boy's size, 26
 Gauging, 25
 Geometry, 4
 —, plane, 31
 —, solid, 31
 Geometrical conventions, 18
 Glaze, polisher's, 46
 Gluing, 43
 Good district, cf. slums, 64
 Gouge cuts, 7
 Grain of wood, 7
 Grinding and sharpening, 30
 Guidance, vocational, 71
- HABITS**, automatic, 9
 —, correct, 9
 —, good craft, 18
 Half-lap joint, 79
 Halving joints, 109

- Handsketching, 18, 33
 Harshness of voice, 16
 Hat and coat rack, 91
 Hessian, use of, 45
 Heuristic method, 5
 Hexagon, 118
 Hints and tips, 79
 History of subject, 2
 Honours book, 11
 Housing joint, 80 and 107
 — double stop, 97
- ILLUSTRATIONS for display, 78
 Imitation, 2
 Indecency, 14
 Individual projects, 17
 Inertia, the boys', 16
 Inferiority due to illness, 16
 Initiative, lack of, 18
 Ink, drawing, 35
 Inkstand, 98
 Instruction cards, 18, 21, 23, 25, 26, 28, 30
 — for weak memory, 18
 — methods, 77
 —, oral, 14, 17
 —, written, 17
 Instructions, display of, 20
 —, repetition of, 17
 —, scope of, 14
 —, test, 53
 —, written, 21
 Instincts, 3, 12
 Interest, efforts to, 17
 Isolation of centre, 13
- JEWISH boys, 52
 Joint, its place in the scheme, 75
 —, bridle, 113
 —, double stopped housing, 97
 —, dovetail, 92, 113
 —, — halving, 110
 —, dowelled, 43
 —, half lap, 79
 —, halving, 109
 —, housing, 80, 107
 —, mortise and tenon, 88, 111
 —, rebate and butt, 84
 —, tee-halving, 110
 —, when to, 42
 Jointing wide boards, 42
 Joints, 3, 4, 5
- LABOURER, the, 9
 Lack of control, 11
 Language, foul, 14
 Lassitude and lethargy, 68
 Lay-out of drawing, 34
 Leg position, 22
 Library, 78
 Light steps, 155
 Lime, 45
- Line, kinds of, 35
 Lining paper, 47
 Listening and doing, 13
 Loci, 118
 Loom, table, 166
 Love, 15
- MACHINES in school, 41
 Manual dexterity, 20
 — instructor, 3
 Marking, 21, 52
 —, the test, 54
 —, sheets for test, 55
 Marks, normal distribution of, 72
 —, test, 73, 74
 Martyrdom, 15
 Mechanization of industry, 2
 Medicine chests, 214, 215
 Memory, weak, 17
 Metalwork, light, 5
 Methods, standardized, 14
 —, alternative, 14
 —, of instruction, 77
 Mimic, the class, 11
 Mirror frames, 102, 103, 104, 105, 204-207
 Misdemeanours, school, 14
 Mistakes, test, analysis of, 70
 — and their causes, 10, 11
 Money box, 150
 Morale, poor, 18
 Mortise and tenon joint, 88, 111
 Mouldings, 77, 142
- NAIL box, 152
 Nails, 77
 Net-ball posts, 167
 Newspaper racks, 215-217
 Noise, workshop, 13
 Normal distribution of marks, 72
 Norms, test, 69
 Novelty, 12, 13
 — and change, 71
- OAK fitment, 164
 Octagon, 118
 Offences, serious, 14
 Oil finish, 44
 — stain, 44
 Oral instruction, 14, 17
 Originality, 3, 6, 10
 Outbreaks, temperamental, 12
 Overloudness of voice, 16
 Over-stimulation, 16
 Overstrain, 16
- PAINTS, use of, 46
 —, cellulose, 46
 Paper, lining, 47
 Parallels, 116
 Pen and ink stand, 151
 Perpendiculars, 116

- Personality, the teacher's, 11
 Photographs of work, 11
 Physical training, 1
 Pictures, use of, 11
 Planed wood, 77
 Planing, 23
 Plate drainer, 95
 Plateau, reason for, 61
 Polish, French and wax, 45
 — brushes, care of, 46
 Polygons, 118
 Poor questioning, 15
 Position at the bench, 20, 22
 Pot. Bichrom, as stain, 46
 Power and speed, 57
 Precision, test, 53
 Prestige, teacher's, 21
 Printing, 34
 Prints, blue, 35
 Progress in the centre, 11
 Project, the individual, 17
 Projection, orthographic, 18
 —, pictorial, 18
 —, axometric, 33
 Proportion, good, 7
 Proportion and ratio, 117
 Punishment, 14, 15
 Putty, 5
 Pythagoras theorem, 118
- QUADRILATERALS, 117**
 Questioning, poor, 15
 Questions, how and why, 18
 —, what, where and when, 17
- RATIO and proportion, 117**
 Ready reckoner, test, 56, 57
 Reason for plateau, 61
 Reasoning, poor, 17
 — by analogy, 17
 Rebate and butt joint, 84
 Rebellious forces, 15
 Records, 36
 Record book, 37
 — card, 36, 79
 Reducing by squaring, 118
 Relationship of accuracy and speed,
 57
 Reports, 37, 79
 Retardation, 61
 Retrogression, 61
 Retrospect, 2
 Reworking an exercise, 10
 Risk, avoidable, 21
 Rivalry, 12
 Rods or staffs, 47
 Routine stage of instruction, 9
- SALES A/C, 8, 77**
 Saw, the craftsman's tool, 14
 Sawing, 23
 Schemes, 4, 6
- Scheme, three stream, 75, 76
 — of joints, 107
 School contacts, 13
 —, contributory, 13
 — for deaf, 67
 — staff meetings, 13
 — misdemeanours, 14
 Scope of instructions, 14
 Scrap wood for practice, 26
 Scumbles, 44
 Secondary school boys, 52
 — boys, cf. elementary school boys,
 61
 — school boys, cf. best elementary
 boys, 63
 Self control, lack of, 12
 — confidence, 20
 — criticism, 1, 21
 Sentiment, 15
 Sharpening and grinding, 30
 Shaving cabinet, 211
 Sheets, test, marking, 55
 Shooting, 28, 29
 Shoe brush box, 16
 Sink tidy, 156
 Silk, use of, 45
 Skill, automatic, 9
 — and complex design, 62
 Slojd, 2
 Slums, cf. good district, 64
 Small stand, 159
 Smoker's outfit, 153
 Soda used as stain, 46
 South Kensington Museum, 7
 Special defects, 21
 — school, 68
 Speed, 7, 20, 53
 — and accuracy, 57
 — contests, 12
 — and drill, 20
 — and power, 57
 Spelling list, 79
 Spoon iron, 3
 Staffs or rods, 47
 Stains, 44-46
 Standards of beauty, 2
 — of conduct, 15
 —, manner and speech, 11
 —, subjective, 59
 — of work, 10, 15
 Standardized lines for drawing, 32
 — methods, 14
 Steps, light, 155
 Stimulants, spiritual, 14
 Stools, 171-202
 Strapwork, carved, 7
 Strength, lack of, 21
 Stubbornness, 12
 Suggestions, what to make, 50
 Sulkiness, 12
 Supply of teachers, 5
 Swing towel rail, 83

- TABLE** lamp standard, 150
Tables, various, 171-192
Tact, 8
Talking too much by teacher, 15
Tangent, the, 117
Taste, 2, 78
 — of artist, 10
Tea tray, 94
Teacher, the luke warm, 11
 —, consciousness of, 14
 —, difficulties of, 14
 —, egotism of, 16
 —, manner of, 11
 —, obsession of, 11
 —, personality of, 11
 —, prestige of, 21
Teaching aids, 11
Teapot stand, 93
Technique, tool handling, 9
Tee square, 154
 — halving joint, 110
Templates, 42, 78, 79
Test conclusions, 70
 —, demonstration, 53
 — errors, 56
 — formula, 56
 — findings, 53
 —, gauge for, 54
 — marking, 54
 — marks, 73, 74
 — norms, 69
 —, ready reckoner, 56, 57
 —, timing, 53
Tests, drawing, 40
 —, instructions for, 53
 —, experimental, 53
 —, term, 39
 —, tools, 53
 —, theory, 40
 — of work, 38
Testing, an experiment in, 51
 —, the natural tools, 21
 —, poor, 21
Theft, 14
Theory, 40
 —, protracted, 3, 4
Three stream scheme, 75
Thrusters, the, 14
Tie rack, 81
Timber, 77
Time sheets, 36, 79
Tool drill, 9, 10, 17, 18 and 20
 — manipulation, 9, 13, 20, 21
Tools, 7
 —, correct use of, 22
 — for tests, 53
"Touching" problems, 118
Toys, 7
Tracing, 35
 — paper problems, 119
Tradition, 1, 7
Training, lack of, 1
Trays, 203, 204
Triangles, 117
Trinket box, 192

UNUSUAL child, 10

VARNISH stair, 46
 —, sticky, 4
Vector, 118
Vigilance of teacher, 12
Virility in a teacher, 11
Visualization, poor, 18
Vocational guidance, 71
Voice of teacher, 11
 —, harshness, 16
 —, overloudness, 16

WAGE, 9
Wall cabinet, 211
Wall charts, 37
Wall posters, 23
Wardrobe, 169
Water stain, 44
Wax polish, 45
What to make suggestions, 50
When to joint, 42
Wide boards, jointing, 42
Will power, lack of, 12
Wood, planed, 77
Word, the written, 21
Work, a boy's plans for, 17
Workshop noise, 13
Work tests, 38

ZINC white, 45

PUBLISHED BY PITMAN

THE TECHNOLOGY OF WOODWORK AND METALWORK

By NORMAN R. ROGERS

*Tutor in Technology for the City and Guilds of
London Institute Examinations, etc.*

THIS book gives a complete account of the tools, materials and processes employed in practical handicraft Woodwork and Metalwork. Students who are training to be teachers of Handicrafts will find the book especially helpful. It completely covers the syllabuses laid down for the examinations of the City and Guilds of London Institute, the Educational Handwork Association, and the various training colleges. The practical way in which it approaches the subject, and the large amount of valuable reference data included, will commend it also very strongly to practising teachers and for pupils' reference purposes. A large section of the book is devoted to essential questions concerning the choosing, handling, care and maintenance of tools and to explanations of the principles upon which they are constructed for their various purposes. The uses of different materials and methods of working, and the difficulties which these may involve, are also fully discussed. The line illustrations, all original, are numerous, clear, and in many cases of unique interest. Full-page plates and charts not hitherto printed are included, and there is a complete index of a thousand entries.

Illustrated

15s. net

338 pp.

SIR ISAAC PITMAN & SONS, LTD. PARKER ST. KINGSWAY, W.C.2

