

BIRLA CENTRAL LIBRARY

PII ANI (RAJASTHAN)

Call No.

665

P23A

Accession No.

45-39

INTERNATIONAL CHEMICAL SERIES

LOUIS P. HAMMETT, PH.D., *Consulting Editor*



The Analysis of
FUEL, GAS, WATER
AND LUBRICANTS

A SELECTION OF TITLES FROM THE INTERNATIONAL CHEMICAL SERIES

LOUIS P. HAMMETT, PH.D., *Consulting Editor*

- Amsden**—
Physical Chemistry for Premedical Students
- Arthur**—
Lecture Demonstrations in General Chemistry
- Arthur and Smith**—
Semimicro Qualitative Analysis
- Booth and Damerell**—
Quantitative Analysis
- Briscoe**—
Structure and Properties of Matter
- Coghill and Sturtevant**—
An Introduction to the Preparation and Identification of Organic Compounds
- Crist**—
A Laboratory Course in General Chemistry
- Daniels**—
Mathematical Preparation for Physical Chemistry
- Daniels, Mathews, and Williams**—
Experimental Physical Chemistry
- Desha**—
Organic Chemistry
- Dole**—
Experimental and Theoretical Electrochemistry
- Eastman and Rollefson**—
Physical Chemistry
- Gibb**—
Optical Methods of Chemical Analysis
- Glasstone, Laidler, and Eyring**—
The Theory of Rate Processes
- Griffin**—
Technical Methods of Analysis
- Hamilton and Simpson**—
Calculations of Quantitative Chemical Analysis
- Hammett**—
Physical Organic Chemistry
Solutions of Electrolytes
- Henderson and Fernelius**—
Inorganic Preparations
- Huntress**—
Problems in Organic Chemistry
- Leighou**—
Chemistry of Engineering Materials
- Long and Anderson**—
Chemical Calculations
- Mahin**—
Introduction to Quantitative Analysis
Quantitative Analysis
- Millard**—
Physical Chemistry for Colleges
- Moore**—
History of Chemistry
- Morton**—
Laboratory Technique in Organic Chemistry
The Chemistry of Heterocyclic Compounds
- Norris**—
Experimental Organic Chemistry
The Principles of Organic Chemistry
- Parr**—
Analysis of Fuel, Gas, Water, and Lubricants
- Reedy**—
Elementary Qualitative Analysis
Theoretical Qualitative Analysis
- Rieman, Neuss, and Naiman**—
Quantitative Analysis
- Robinson and Gilliland**—
The Elements of Fractional Distillation
- Schoch, Felsing, and Watt**—
General Chemistry
- Snell and Biffen**—
Commercial Methods of Analysis
- Steiner**—
Introduction to Chemical Thermodynamics
- Stillwell**—
Crystal Chemistry
- Stone, Dunn, and McCullough**—
Experiments in General Chemistry
- Thomas**—
Colloid Chemistry
- Timm**—
General Chemistry
An Introduction to Chemistry
- Watt**—
Laboratory Experiments in General Chemistry and Qualitative Analysis
- Williams and Homerberg**—
Principles of Metallography
- Woodman**—
Food Analysis



SAMUEL WILSON PARR (1857-1931)

(Frontispiece)

The Analysis of

**FUEL, GAS, WATER
AND LUBRICANTS**

by S. W. PARR
Late Professor of Applied Chemistry,
University of Illinois

*Fourth Edition
Twelfth Impression*

McGRAW-HILL BOOK COMPANY, INC.

. NEW YORK AND LONDON

1932

COPYRIGHT, 1922, 1932, BY THE
MCGRAW-HILL BOOK COMPANY, INC.

COPYRIGHT, 1911, 1916, BY S. W. PARR

PRINTED IN THE UNITED STATES OF AMERICA

*All rights reserved. This book, or
parts thereof, may not be reproduced
in any form without permission of
the publishers.*

AN APPRECIATION

It is a privilege to be given an opportunity to express here my appreciation of Professor S. W. Parr's outstanding contributions to the advancement of applied chemistry and chemical technology.

I am convinced that my expression of such appreciation is truly representative of that of the great body of students who had the benefit of his training and influence during his 35 years of teaching at the University of Illinois. It is characteristic of the man that, in his preface to the first edition of "The Analysis of Fuel, Gas, Water and Lubricants," he gives credit for the success of his courses to "the students [whose] responsiveness has been the main stimulus" for his work. But the students know the real reason for his success.

Professor Parr made chemistry interesting to those learning to use it and apply it in their work. He had the gift of simple and direct expression and of transmitting to others the gist of an array of facts or of a fundamental principle and of showing its practical application.

In the chemistry of coal and in calorimetry of fuels he made probably his greatest contributions. Known throughout the world for his work in these fields, he advanced our knowledge along some lines probably more than any other one man. He was the first to bring out the fundamental importance, in coal use and classification, of the varying composition of the volatile matter, as well as of its varying amount. He studied more extensively than any one else the carbonization of the higher-oxygen type of coal and brought out fundamental reactions and principles concerned therewith that are of the utmost value to the art.

In other fields, notably boiler waters and metal alloys, his researches are well known, and their practical value generally recognized. In making his teachings and his researches intelligible and useful throughout a practical world, he particularly excelled. "The Analysis of Fuel, Gas, Water and Lubricants," revised again during the last year of his life, bears testimony to this fact.

HORACE C. PORTER.

PREFACE TO THE FOURTH EDITION

The revision of this book has been made difficult by the death of the author just before the completion of his task. With a thorough outline of his ideas, however, it has been possible to finish it in such a way that its character remains essentially his.

The author aimed in this edition to cover the rapid progress made in the last decade by research in the technology of fuels and in the utilization of the results by the industries. In the new topics presented in Part I, an attempt has been made to give the student an idea of the research method of attack on new and difficult problems. The purpose of this is not only to foster the idea of creative thinking but also to facilitate a better understanding of modern technical literature. Opportunity has thus been given to include a brief description of the newer work on the constitution of coal and its relation to carbonization, and of the effect of boiler waters on steel.

Special acknowledgment is made to Dr. H. F. Johnstone for his services as an advisor after the author's death. Thanks are also due to Professor A. C. Callen for revision of the chapter on Coal Contracts. Other friends and former students of Professor Parr who have contributed time and efficient help on selected topics are Dr. R. D. Snow, Dr. A. C. Robertson, Messrs. D. R. Mitchell, F. G. Straub, Floyd B. Hobart and Wayne D. Staley. To these grateful appreciation is expressed in memory of my brother.

FRANCES M. PARR.

URBANA, ILLINOIS,
January, 1932.

PREFACE TO THE FIRST AND SECOND EDITIONS

This work is intended primarily for Juniors in Mechanical and Railway Mechanical Engineering at the University of Illinois. From the chemical standpoint, it is a very serious problem to know what may profitably be attempted in the way of analytical methods in the case of students whose chemical experience is meager. But, however unsatisfactory the amount of preliminary training, it is obvious that the curriculum in Engineering courses is already overcrowded; hence the obtaining of a better prerequisite in chemistry is well nigh impossible. The work as herein outlined is the result of ten years of effort to make the most of the situation. It would be quite too much to claim that in the evolution of the work a satisfactory status has been attained. It is hoped, however, that the course will at least help the engineer to a better understanding of the literature of the topics considered and also to an appreciation and, consequently, a more intelligent use of data which may come into his hands from the chemist. It may not be out of place to state further that the course, which, at the first, was inaugurated with no little misgiving, has more than justified the experiment. For this result credit is due the students, who from year to year have carried the work through with a responsiveness which has been the main stimulus in developing this outline into its present form.

Part I is a synopsis only of the lectures given. Part II consists essentially of laboratory directions for the analytical methods there undertaken. The time allowance for lectures, quizzes, and laboratory is nine hours per week for 18 weeks. The amount of work as outlined is such that the average student covers the ground in the time prescribed.

Special acknowledgment is due Dr. H. J. Broderon for suggested improvements in the present edition and for valued assistance in the reading of proof.

CONTENTS

	PAGE
AN APPRECIATION BY HORACE C. PORTER	vii
PREFACE TO THE FOURTH EDITION.	ix
PREFACE TO THE FIRST AND SECOND EDITIONS.	x
PART I	
LECTURES	
CHAPTER I	
POWER	1
Introduction—Motion—Gravity—Heat and Energy—Molecular Action—Fuel Types.	
CHAPTER II	
DISTRIBUTION AND PRODUCTION OF COAL	6
Historical—Distribution of Reserve Supplies—Distribution of Types—Coal Production—Uses of Coal.	
CHAPTER III	
THE DEVELOPMENT OF FUEL RESEARCH.	20
Marcus Bull—Walter R. Johnson—The St. Louis Coal Tests—The Bureau of Mines.	
CHAPTER IV	
CALORIMETRY IN AMERICA.	26
Count Rumford—The Atwater Calorimeter—The Parr Calorim- eters.	
CHAPTER V	
THE CONSTITUTION OF COAL.	34
Introduction—Coal Structure—Coal Bands—Microscopical Study of Coal—Significance of Constituents.	
CHAPTER VI	
THE CLASSIFICATION OF COAL	42
Introduction—Historical—Fundamental Factors in Classification, Oxygen and Volatile Matter Content—Unit Coal—Unit B.t.u.—	

	PAGE
Evidence of Accuracy of Formula for Unit Coal—Correction for Coals with High Carbonate Content—Significance of Volatile Matter—Use of Calorific Value and Percentage Volatile Matter as Basis of Classification—Representative Analytical Data for Type Samples of Solid Fuels—Derivation of the Factor 5,000 <i>S</i> .	
CHAPTER VII	
OXYGEN ABSORPTION BY COAL	61
Introduction—Experimental Methods—Results of Oxygen-absorption Studies—Relation of Oxygen Absorption to Storage of Coal.	
CHAPTER VIII	
THE IGNITION TEMPERATURE OF COAL	69
Initial Appearance of Carbon Dioxide—Critical Oxidation Temperature.	
CHAPTER IX	
THE STORAGE OF COAL	75
Slacking of Coals—Effect of Storage on Unit Coal and Ash Content—Boiler Tests on Weathered Coal—The Effect of Sulfur on Spontaneous Combustion—Heating of Coal in Storage—Conclusions.	
CHAPTER X	
COMBUSTION OF COAL	86
General Principles—Oxygen Supply—Smoke—Clinker Formation—Fusibility of Ash—The Wetting of Coal—Pulverized Fuel.	
CHAPTER XI	
IMPURITIES IN COAL	95
Classification — Moisture — Ash — Sulfur — Phosphorus — Distribution of Ash and Sulfur in Sizes—Distribution of Impurities in the Coal Bed.	
CHAPTER XII	
COAL CONTRACTS	103
Introduction—Buyer and Seller—Basis for Specifications—Double Ash-penalty—Other Variables—Invitations for Bids—Comparison of Bids—Acceptance Limits—Computation of Settlement Price—Formulation of Proposals—Attitude of Buyer and Seller.	
CHAPTER XIII	
SMOKE	116
The Smoke Evil—Sanitation of the Air.	

CHAPTER XIV

- THE FUNDAMENTAL PROPERTIES OF COAL RELATED TO CARBONIZATION** 121
 Action of Solvents on Coal—Effect of Oxygen on Lignitic and Bituminic Portions—Softening Temperature of Coal—Summary—A Carbonization Theory.

CHAPTER XV

- CARBONIZATION METHODS.** 133
 Classification According to Temperature—High Temperature Carbonization—Low-temperature Carbonization—Mid-temperature Carbonization.

CHAPTER XVI

- PROCESSED FUELS—COKE AND BRIQUETS** 139
 Coke—The Reactivity of Coke—Fuel Briquets.

CHAPTER XVII

- FUEL GAS.** 145
 Introduction—Producer Gas—Water Gas—Carbureted Water Gas—Coal Gas and Coke-oven Gas—Complete Gasification—Natural Gas—Refinery Gas.

CHAPTER XVIII

- WOOD** 153
 Calorific Value and Moisture Content.

CHAPTER XIX

- LIQUID FUELS** 157
 Petroleum — Historical — Production — Refining — Other Liquid Fuels.

CHAPTER XX

- BOILER WATERS, THEIR CHARACTER AND TREATMENT** 162
 Water Analysis—Source of the Mineral Constituents—Chemical Characteristics of the Mineral Constituents—Solubility of Gypsum—Effect of Impurities—Classification of Waters—Effect of Scale—Corrosion Sources—Foaming—The Chemical Treatment of Boiler Waters—Treatment with Lime—Treatment with Soda Ash—Treatment with Coagulants—Industrial Methods—Zeolites.

CHAPTER XXI

- EMBRITTLMENT OF BOILER PLATE** 177
 Historical—Reactions of Sodium Bicarbonate Waters in the Boiler—Cause of Embrittlement—Prevention of Embrittlement—The A.S.M.E. Boiler Code.

CHAPTER XXII

LUBRICANTS	185
Introduction—Animal and Vegetable Oils—Mineral Oils—Com- pounded Oils—Testing—Deterioration of Automobile Lubricating Oils.	

PART II

LABORATORY METHODS

CHAPTER XXIII

THE SAMPLING OF COAL	194
Introduction—Necessity of Care—Material to Be Taken—Amount —Ratio of Size to Mass—Mixing and Subdividing—Riffling— Sampling a Carload—Composite Samples—Mechanical Sampling —Grinding the Sample—Moisture Control—Sampling of Pulver- ized Fuel.	

CHAPTER XXIV

THE PROXIMATE ANALYSIS OF COAL	208
Introduction—Moisture and Nomenclature—Moisture Loss on Air Drying—Laboratory Sample—Moisture in the Laboratory Sample—Total Moisture—Ash—Volatile Matter—Fixed Carbon— Calculations.	

CHAPTER XXV

THE CALORIMETRY OF FUELS—THE OXYGEN-BOMB CALORIMETER . . .	218
Definitions—Heat Values by Calculation—Berthier Test—Lewis Thompson Calorimeter—Types of Oxygen Calorimeters—Parr Oxygen-bomb Calorimeter—Heat Values by Oxygen-bomb Calori- meter—The Parr Adiabatic Calorimeter.	

CHAPTER XXVI

THE CALORIMETRY OF FUELS—THE SODIUM PEROXIDE CALORIMETER	242
Principles—Directions for Operating.	

CHAPTER XXVII

SULFUR DETERMINATIONS	256
General Statement—Total Sulfur in Coal—Sulfur Turbidimeter— Sulfur in Petroleum Oils Heavier than Illuminating Oil—Sulfur in Motor Fuels, Naphthas and Illuminating Oils by Lamp Method.	

CHAPTER XXVIII

THE ULTIMATE ANALYSIS OF COAL—SHORT METHOD	268
Introduction—Total Carbon—Sulfur—Hydrogen—Oxygen.	

CHAPTER XXIX

FUEL-GAS ANALYSIS	276
Apparatus—Manipulation and Description of Reagents—Derivation of Calculations—Sulfur—Heat Values by Calculation—Direct Determination of Heat Values—Gross and Net Heating Values—Specific Gravity of Gas.	

CHAPTER XXX

THE ANALYSIS OF FLUE GASES	301
Sampling and Analysis—Orsat Reagents—Procedure—Calculation of Efficiencies and Heat Losses—Other Losses.	

CHAPTER XXXI

ANALYSIS OF BOILER WATERS	310
Normal Solutions—Standard Sodium Carbonate—Standard Sulfuric Acid—Determination of Sulfur—Standard Calcium Chloride and Soap Solutions—Standardization of the Soap Solution—Determination of Calcium Sulfate in Water—Excess of Free Carbon Dioxide—Total Alkalinity and Temporary Hardness—Magnesia—Permanent Hardness—Negative Hardness—Total Hardness—Determination of Total Sulfates—Determination of Total Chlorides—Total Alkalies—Examination of a Treated Water—Examination of Boiler Concentrates—Determination of Soluble Phosphate in Boiler Concentrates—Summary of Results and Calculations.	

CHAPTER XXXII

EXAMINATION OF LUBRICANTS	329
Viscosity—Flash and Fire Test—The Conradson Test—Cloud and Pour Points—Emulsification—The Steam Emulsification Test—Free Acid—Saponification Number—Maumené Test—Specific Gravity—Color—Grease Examination.	

APPENDIX	349
--------------------	-----

INDEX	365
-----------------	-----

THE ANALYSIS OF FUEL, GAS, WATER AND LUBRICANTS

PART I LECTURES

CHAPTER I POWER

Introduction.—It is the purpose of this book to present from a chemical standpoint the fundamental factors which pertain to the production of power.

There is probably nothing more universally fascinating, especially in the juvenile stage of our existence, than to “see the wheels go round.” It is Dryden who says that “men are but children of a larger growth,” and it is quite within the bounds of truth to say that in our modern civilization, dominated as it is by industrial activities, we all like to see the wheels go round, for reasons that range from curiosity and interest in the spectacular to bread-and-butter requirements of everyday living.

If the wheels go round there is motion, and motion produces motion; hence, if motion is harnessed, controlled and directed, it becomes power, and power, when measured, becomes a commodity. We are at once interested, therefore, in knowing what motion is and where it comes from. We need to have it defined in terms of its initial source. Let us attempt an analysis of that phase of the subject.

Motion.—If motion produces motion, our quest for its ultimate source would lead us back to the molecule, with the obvious result that chemical action was the initial process. However, to keep within the range of our everyday experience and observa-

tion we may consider the phenomenon of motion in its grosser manifestations to be definable as follows:

Motion is the concrete, sensible and understandable product of the obscure and not readily comprehended entities which we call force and energy. These have their origin in

1. Gravity.
2. Molecular or chemical action.

Gravity.—The force of gravity is inherently operative in all forms of matter, whether solid, liquid or gaseous. It is obvious, therefore, that the first utilization of force in a mechanical way by man was associated with the mobile forms of matter, such as wind and water, as illustrated in the windmill, the sailing ship, and the water-wheel in "The Sun as the Source of Power" (facing page 1).

Heat and Energy.—It was not until the close of the eighteenth and the opening of the nineteenth century that the relation between heat and energy began to be formulated. While Locke, for example, about the year 1700 had said that "what in our sensation is heat, in the object is nothing but motion," it was 100 years later before Rumford formulated the mechanical theory of heat, and Watt, at about the same time, developed the mechanical method of transferring molecular motion to work as exemplified in the steam engine.

Molecular Action.—This brings us again to the statement that motion, whether massive as in the case of gravity, or molecular as in the case of chemical action, in turn, produces motion, and thus reveals that, even including gravity as here considered, the source of power is dependent upon molecular motion which has its origin in chemical action.

Now, the most abundant and the cheapest reserve of potential activity of a chemical sort resides in the stored-up energy acquired through geological ages in the form of hydrocarbon compounds which, in our everyday speech, we refer to as fuel, in the form of coal, oil and gas. Here it is apparent that the chemical activity of the sun has had a great deal to do with the storage process. However that does not alter but rather emphasizes the general proposition that chemical action is the initial source of motion. It is at once obvious that there is a direct and vital relation between cheap and abundant chemical reserves and the industries.

Commerce does not follow the flag; it follows the molecule, provided only that there be enough of them, and at a price and of a sort to make the wheels go round. In our day and age there is nothing more obvious than that commerce and the industries are drawn, as by some unseen force, into the environment, or to the ready accessibility of these storehouses of potential motion, in the form of the coal, oil and gas supplies stored up by a generous past.

From these general observations concerning the relation of fuels to present-day activities, it is at once evident that, from the chemical standpoint especially, we shall want to know the fundamental facts concerning fuel types, distribution, character, properties, composition and heat value as basic and indispensable factors which must be available to any one engaged in the use or sale of fuel for either heating purposes or the commercial generation of power. It will be appropriate, therefore, at the outset to list those various sources of chemically active materials which, because of their abundance or accessibility, or form value, may be designated as *fuel*.

Fuel Types.—For convenience in this discussion, fuels may be tabulated under three general forms: *solid*, *liquid* and *gaseous*. Each of these may further be discussed under subheadings which will be mentioned here only as indicating the general topics to be taken up later in detail under appropriate chapter headings.

Fuel	Solid	Coal
		Wood
		Coke
	Liquid	Processed Fuels
		Petroleum
		Distillates
		Alcohol
	Gaseous	Artificial Gas
		Natural Gas
		Synthetic Gas

The listing of these various types of fuel discloses the evidence of activity in the development of *new fields*, *new types* and *new supplies*. The chart, Fig. 1, shows the relative distribution of the fuel supplies, based on statistical data for the year 1929. The unit of comparison is the amount of coal which will give an

equivalent number of British thermal units. The segments of the circle represent directly, by their relative areas, the percentage value of the various forms of fuel as produced for a typical year in the United States.

The foregoing informational topics and discussions occupy Part I of this book.

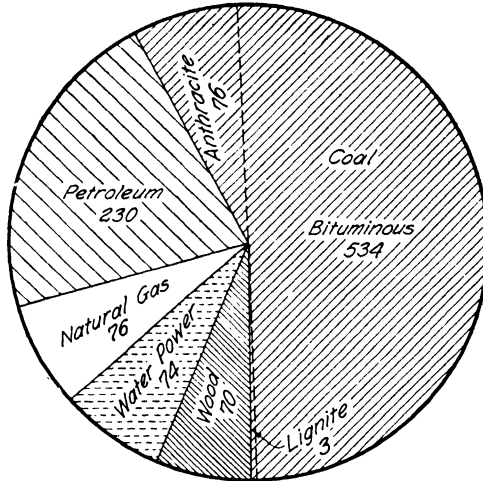

*Numbers represent millions of tons
for an average year.*

FIG. 1.—Total fuel production of the United States, in tonnage equivalents having thermal values corresponding to coal. One ton of coal is considered equivalent to 3 barrels of petroleum, 2 cords of wood, or 2,600 cu. ft. of natural gas. Four and one-half tons are considered equivalent to 1 hp. water power operating an average year of 3,000 hours. The total bituminous coal represents substantially 50 per cent of the power. Anthracite, natural gas, water power and wood average each approximately 7 per cent of the total power. Petroleum furnished approximately the equivalent of 21 per cent of the total power produced. These values are based in the main on the production of power for the year 1929 as indicated in the *Weekly Coal Reports and Supplements* of the U. S. Bureau of Mines.

There will be evidence of an increasing divergence in the values and heat-producing properties of the fuels mentioned, and a consequent need of adequate and accurate methods for evaluating the various fuels now or prospectively available. Such methods involve the determination of the amount and character of the organic or combustible material, or, quite as important,

the determination of the amount of inorganic, inert or chemically inactive material, or actual combustion of the fuel whereby it is made to indicate its potential activity by the evolution of heat, the quantity of which is accurately measured. These latter topics will be treated in detail in Part II under the general title of Analytical Methods.

CHAPTER II

DISTRIBUTION AND PRODUCTION OF COAL

Historical.—Louis Joliet and Father Marquette, in connection with their journey of exploration from Lake Michigan, noted the presence of coal in the region lying north of the Illinois River in the vicinity of the present city of Utica, Ill. A part of Joliet's map describing the expedition of 1673 is reproduced in Fig. 2.

Early in that year these two explorers left Green Bay, Wis., going westward by way of the Fox and Wisconsin rivers, then south on the Mississippi as far as the Arkansas River. Turning northward July 17, they journeyed by way of the Illinois River and Lake Michigan, arriving at Green Bay some time in September. The map reproduced was probably made by Raudin, Frontenac's engineer, who based his work largely on the record transmitted by Marquette, since Joliet's original records were lost in the St. Lawrence rapids on his return to Quebec. The map is of interest in this connection because of its reference to coal (*charbon de terre*) in the neighborhood of the Indian village designated as "Kachkachkia."

The meager details of this map are materially supplemented by other maps of that period. For example, in a German text published by Hennepin in 1689 is a map, illustrated in Fig. 3,¹ which is obviously a copy of the one published by Thévenot in 1681.² The latter has many errors, some of which are corrected by Hennepin. Hennepin has translated the names on the map, so far as was possible, into Latin. The chief errors are those of relative locations. For example, the village of the Illinois Indians is shown as slightly west of the mouth of the "Lapides Haematitiae" (Vermilion) River, whereas it should be shown

¹ Photographed from "Beschreibung der Landschafft Lovisiana," original German edition, Nuremberg, 1689.

² See *Proc.*, State Historical Soc. Wis., p. 184, 1906.

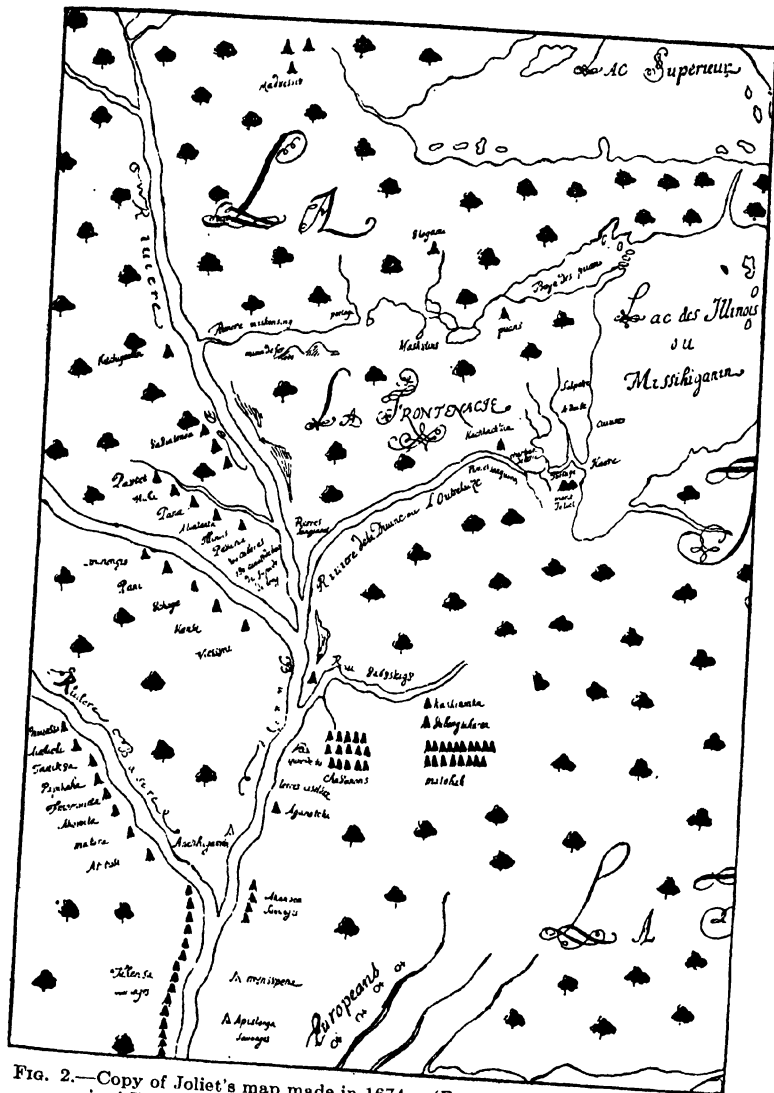

Fig. 2.—Copy of Joliet's map made in 1674. (From "A History of the Mississippi Valley," by Spears and Clark, A. S. Clark, Publisher, 1903.)

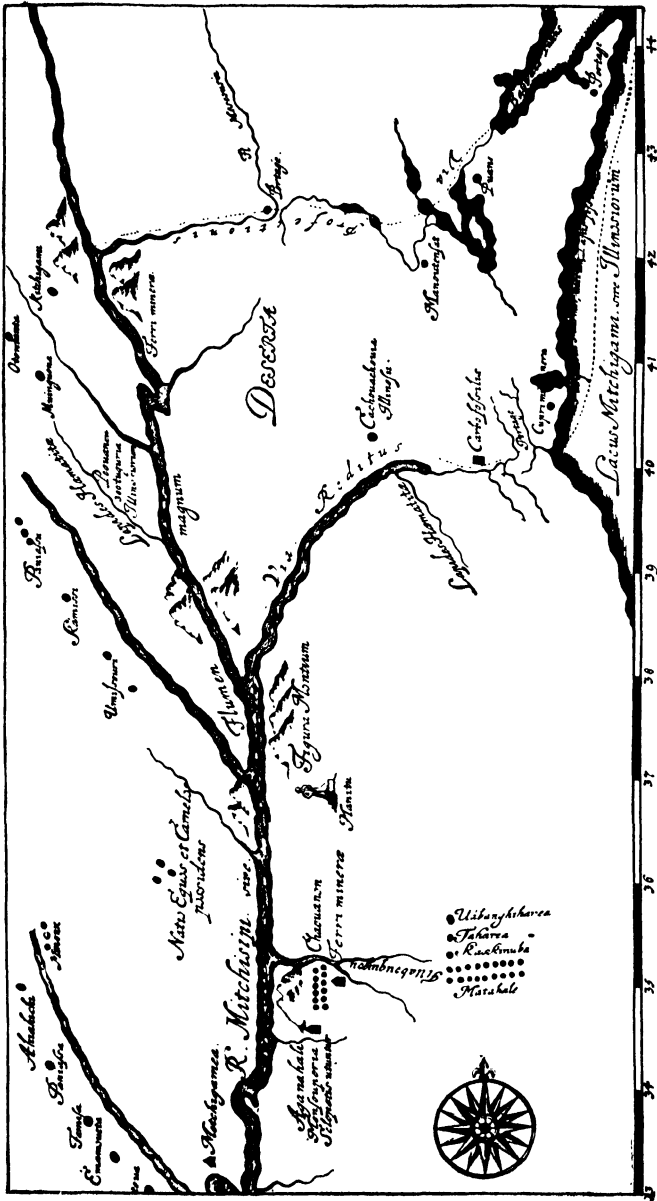

FIG. 3.—Hennepin's map of 1689 showing the location of the Illinois country.

about $1\frac{1}{2}$ miles east of the mouth of that river. Also, Joliet's notation of the *charbon de terre* would seem to make it contiguous to Kachkachkia, whereas Hennepin locates it too far eastward.

It is of interest to note for comparison this portion of the great map of Franquelin (1684), which was made with far greater skill, as he was an engineer and the official hydrographer located at Quebec. This map is shown in Fig. 4.¹ He obviously also had at hand much more detailed information. In his map he shows correctly Fort St. Louis, now known to have been located on top of Starved Rock. The mouth of the Vermilion River is also correctly shown at a short distance west of Fort St. Louis and the very large village of the Illinois ("twelve hundred warriors") is shown nearly opposite, or slightly west of Fort St. Louis. This village was located very near the present city of Utica.

In this somewhat roundabout but well-authenticated manner is definitely located Joliet's notation of *charbon de terre* in 1673, the first record of the existence of coal on the American continent.

Notwithstanding this early discovery of coal by Joliet, the actual mining of coal in Illinois occurred practically contemporaneously with the earliest production of anthracite in Pennsylvania. The first recorded shipment of coal in Illinois was made from a point on the Big Muddy River where a flatboat was loaded in 1810 and sent down the river to New Orleans.² Another shipment of several boat loads was made in 1832, but while these ventures were nearly 160 years after the initial discovery of the coal, they were still very much ahead of the times. Even at this time, a century ago, the use of fuel was confined almost exclusively to the supplying of household needs, such as cooking and space heating.

The industrial wheels had not yet begun to turn. In fact, there were no industrial wheels, and there were none because this potential power for bringing them into existence and giving them motion had not passed beyond the stage of discovery.

In 1821 the official figure for the production of coal in the United States was 1,322 tons, all anthracite. It was only 5 years previous, in 1816, that Fulton had made his first trip on the Hudson, and it was 20 years after that date, in 1836, before

¹ Photographed from Parkman, "Discovery of the Great West," 1869.

² "Mineral Resources of the United States," 1904, p. 403.

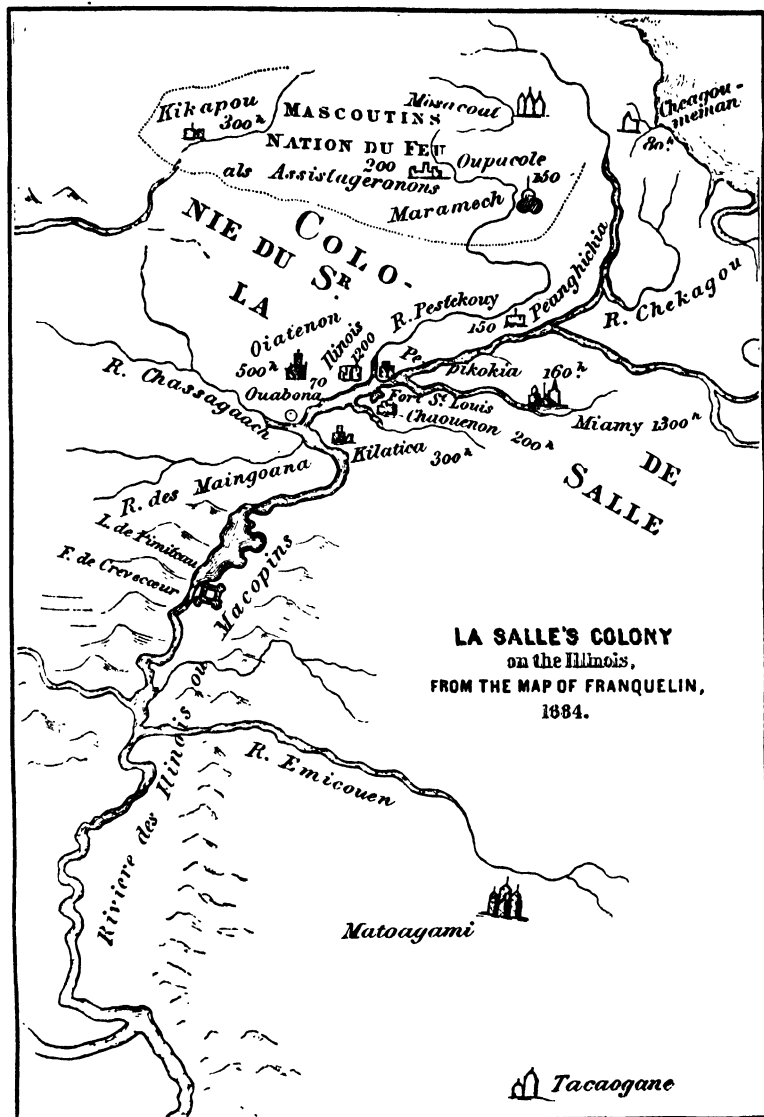

FIG. 4.—Portion of Franquelin's map, 1684.

the first transoceanic voyage was made by steam. The first locomotive had not yet been fired up and when it was, in 1829, the fuel used was wood.

The estimated production of all coal for the entire United States in 1830 was 320,000 tons, representing a little more than one-fiftieth of a ton per capita. From that status we have advanced to a total of nearly 550,000,000 tons in 1930, or a little less than 5 tons per capita. Of this tonnage, about 10 per cent is anthracite, and the balance is bituminous coal having an estimated value at the mines of \$1,500,000,000, and to the consumer—with shipping and handling charges added—the annual cost would probably approximate \$5,000,000,000. If we add to this account the accession of other sources of energy, such as petroleum and natural gas, the equivalent tonnage in terms of coal would represent a total of over 1,000,000,000 tons.

It is only by such a backward glance that we are able to arrive at any adequate appreciation of the phenomenal accomplishments in the utilization of fuels which has characterized the past 100 years.

Distribution of Reserve Supplies.—The coal deposits have not been as evenly distributed as most of the other natural resources of the world. Europe and America have been more generously supplied with this source of power than other divisions of the earth's surface. This fact, indeed, might be inferred from the highly developed industrial activity of these favored regions. The coal deposits next in order of significance are those of China, which suggests that, potentially at least, that country has before it great manufacturing possibilities. The combined reserves of these three intensified coal regions have been computed from the estimated coal resources of the world, and are given in Table I. The remaining reserves, credited to the continents of Australia, Africa and South America, are meager, having only about 3 or 4 per cent for their combined values. It should be noted, however, that there are vast areas in those regions where but little is known as to coal or other fuel resources.

Distribution of Types.—In North America, by far the larger part of the coal, ranking above the lignites, is found in the United States. In Asia, the larger deposits are found in China, while in all of Europe over 90 per cent of the coals of the higher

TABLE I.—COAL RESERVES OF THE WORLD INCLUDING LIGNITE¹

Region	Available tons (millions)	Percentage of total
North America.....	5,073,431	68.7
Canada.....	1,234,269	16.7
United States.....	3,838,657	52.0
Colorado.....	297,975	4.0
Illinois.....	182,758	2.4
West Virginia.....	138,425	1.8
Pennsylvania.....	121,210	1.6
Kentucky.....	111,913	1.5
Ohio.....	85,270	1.1
Alabama.....	61,327	0.8
All other states.....	2,839,779	38.8
Remainder of North America.....	505	0.0
Europe.....	784,190	10.6
Germany.....	378,475 ²	5.1
Great Britain and Ireland.....	189,533	2.6
Poland.....	63,900	0.9
Russia.....	60,106	0.8
France.....	17,583	0.2
Belgium.....	11,000	0.1
Netherlands.....	4,402	0.1
Remainder of Europe.....	59,191	0.8
Asia.....	1,279,586	17.3
China.....	995,586	13.5
Siberia.....	173,897	2.3
India.....	79,001	1.1
Remainder of Asia.....	31,102	0.4
All other regions.....	260,346	3.4
Total reserves of the world.....	7,397,553	100.0

¹ Data from Coal reserves of the world: 12th Internat. Geol. Cong., Toronto, 1913. See also The coal industry of the world: U. S. Dept. Commerce Trade Promotion Ser., Bull 105, 1930.

² Corrected for territorial losses to Poland but includes the Saar district.

ranks are in Germany, Great Britain, Poland, France and Belgium.

Another striking feature is the variation in lignites. Canada, for example, has more lignitic deposits than all of the bituminous deposits of North America combined. They are, moreover, exceptionally high grade, being mainly of the sub-bituminous

type.* In the United States alone, the lignites are about equal in tonnage to the coals of the bituminous type. In Asia, on the other hand, the lignites are insignificant in amount, being less than one-tenth of the coals of higher rank, and in Europe even more pronounced differences exist, the lignites being substantially only 5 per cent of the tonnage reserves of bituminous coal.

It is interesting to note that the main coal-producing areas of Europe, including Great Britain, amount to approximately 18,000 sq. miles,¹ which is only about one-third of the mid-continental or Illinois area lying east of the Mississippi River and extending over into southwestern Indiana and western Kentucky.

The Illinois area is well shown in its relation to other coal regions of the entire United States by reference to the accompanying Figs. 5 and 6. Moreover, the estimated tonnage reserves for this area are equivalent to about $1\frac{1}{3}$ times the total bituminous reserves of Pennsylvania and West Virginia.

Coal Production.—The annual production of coal as charted for the United States for the past 50 years furnishes an interesting study. By reference to Fig. 7 the great increase in the output of bituminous coal, beginning with the year 1880, becomes evident. From the year 1897 the almost uninterrupted increase for the next 20 years was so pronounced as to raise the question as to the possible exhaustion of our entire coal reserves within the relatively near future. Of course it was impossible that the indicated rate of increase could continue indefinitely. The limitations of the possible magnitude of the industrial expansion alone would require a flattening out of the curve. Other elements of a more or less unexpected sort have entered into the coal requirements, such as the phenomenal increase in the output of natural gas and petroleum, and the equally pronounced increase in the efficiencies secured by the modern superpower stations and by the present-day railway locomotives. The charts shown in Figs. 8 and 9 graphically illustrate these developments.

Uses of Coal.—It will be of interest to observe the various purposes which the half-billion tons of bituminous coal annually mined in the United States serve. The relative demands in a typical year of industrial activity, 1929, are shown in Fig. 10.

¹ Coal reserves of the world: 12th Internat. Geol. Cong., Toronto, 1913.

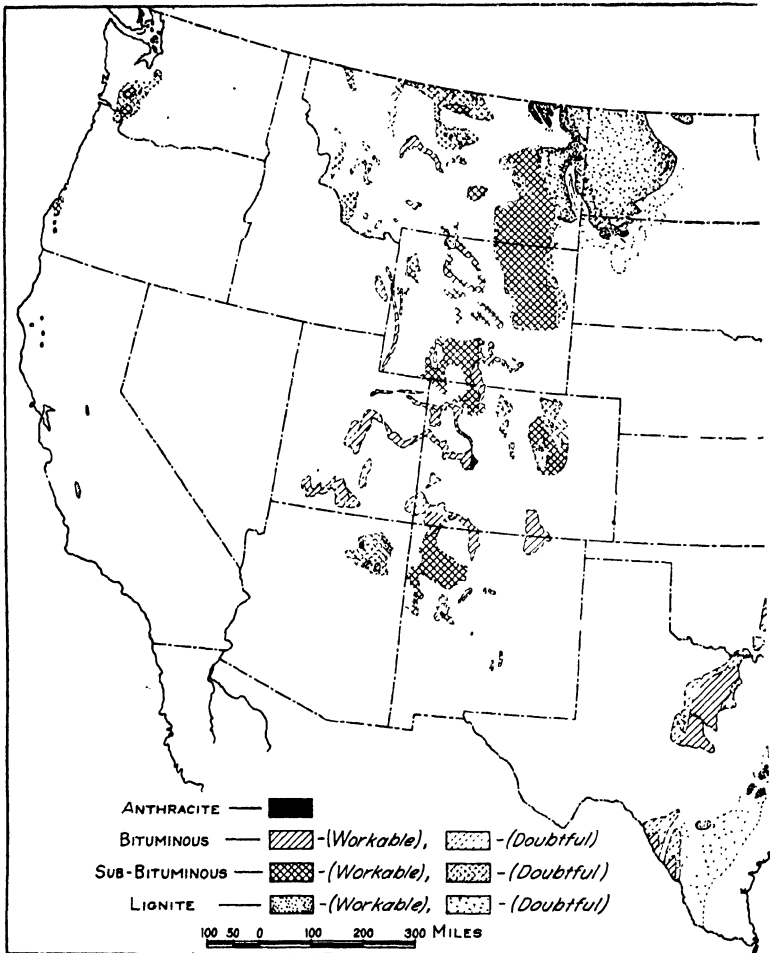

FIG. 5.—Coal areas of the western United States.

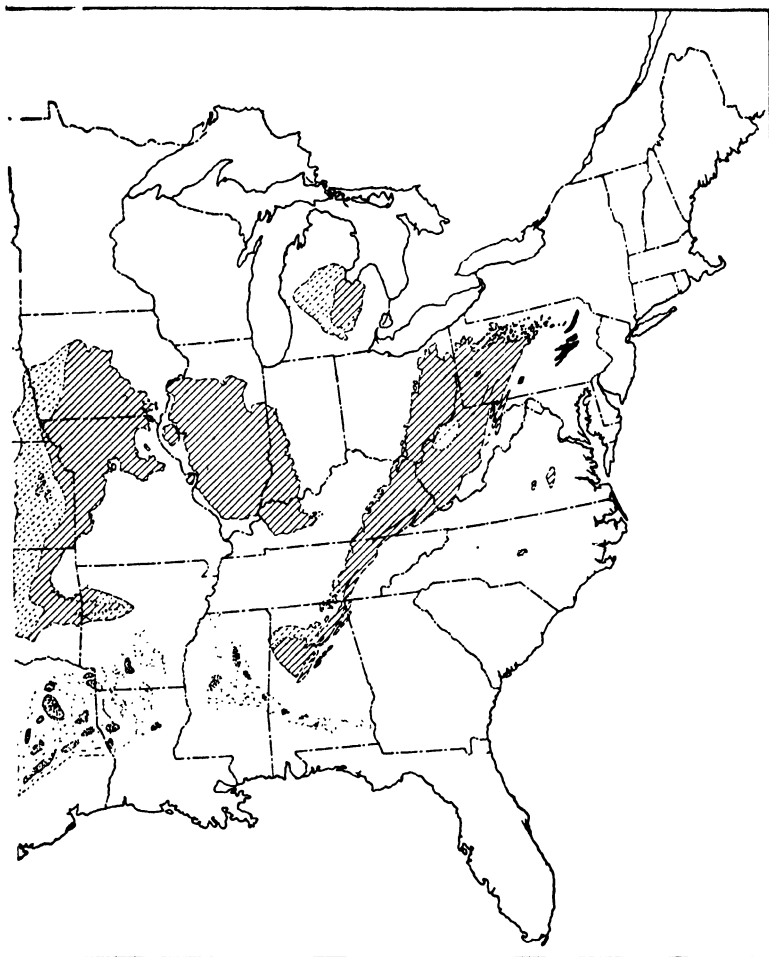

FIG. 6.—Coal areas of the eastern United States.

As a class, the steam railroads are by far the largest consumers—utilizing 25 per cent of the total.

Ranking with the railroads and using an equal amount is domestic consumption, with which might be included the heating of large buildings such as hotels, apartments, stores, theaters, garages, etc., and small industrial consumers.

The next class of users in percentage of consumption is the general manufacturing group which consumes 21 per cent or over 100,000,000 tons annually. Chief in importance here are the

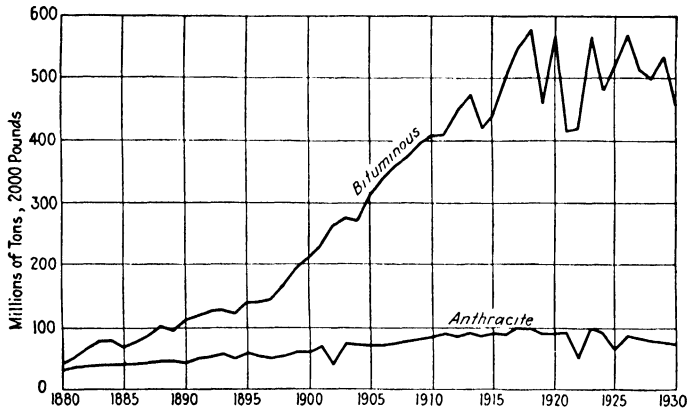

Fig. 7.—Annual output of coal in the United States, 1880–1930.

stone, clay, and glass industry consuming 4.6 per cent and the metal industries other than steel works consuming 3.5 per cent. Other large users of general interest are food products, 2.3 per cent; chemicals and fertilizers, 2.1 per cent; petroleum refining, 0.8 per cent; and automobiles, 0.5 per cent.

Next in order are the coke ovens, which absorb 16 per cent of the total, or 80,000,000 tons. So great has been the growth of the by-product methods of coking that less than one-tenth of this amount is now used in bee-hive ovens.

The electric utilities, which rank next in importance of coal consumption, use less than might be expected because of the high thermal efficiencies already mentioned. In 1929 their demand was only 8 per cent of the total.

When business conditions are favorable, the iron and steel industry uses about 25,000,000 tons, or 5 per cent of the bitumi-

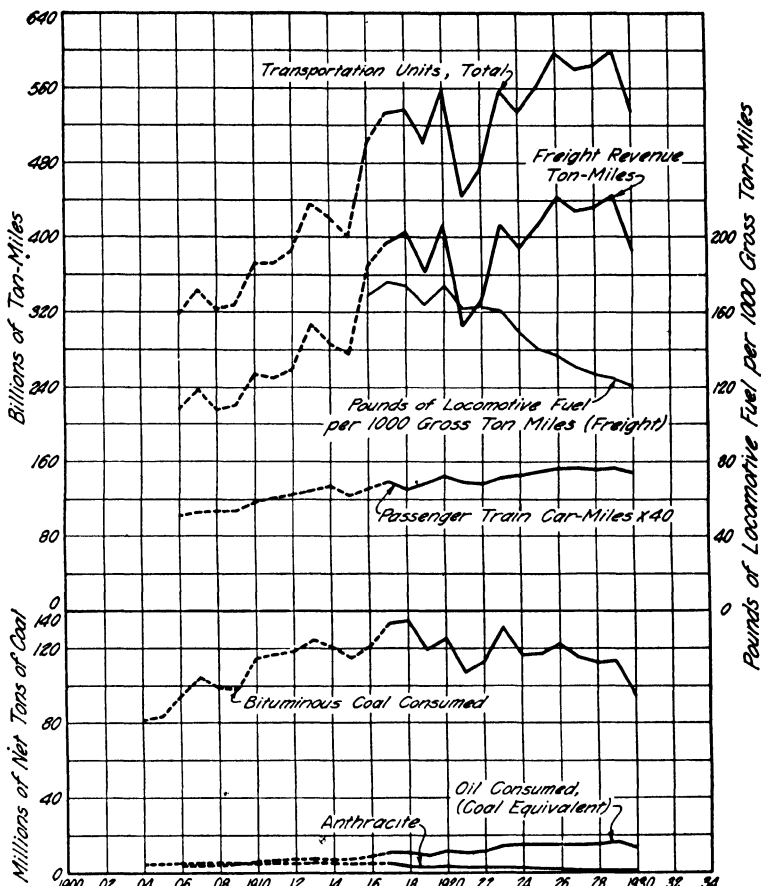

Fig. 8.—Trend in fuel consumption by steam locomotives.¹

¹The curves for the period 1904–1916 are those given by Tryon and Rogers, *Proc. 2d Internat. Conference on Bituminous Coal*, vol. 1, p. 156, 1928. Data for the extension of these curves were obtained from the *Annual Reports of the Interstate Commerce Commission on Statistics of Railways in the United States*. The data for the fuel consumption by freight locomotives per 1000 gross ton miles were taken from Bureau of Railway Economics, *Special Ser. 57*, p. 31, 1931, and from Bureau of Mines *Report on Coal* in 1928, p. 509.

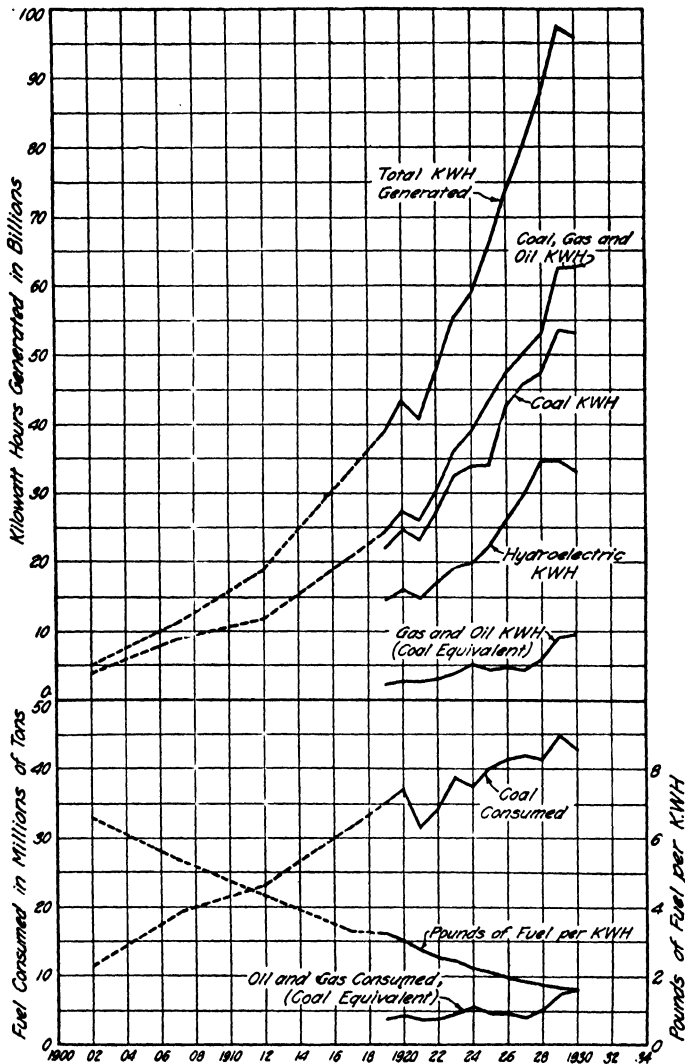

FIG. 9.—Trends of fuel consumption and power production by public-utility plants.¹

¹ Curves for the period 1902–1918 are those given by Tryon and Rogers, *Proc. 2d Internat. Conference on Bituminous Coal*, vol. 1, p. 160, 1928. Data for the extension of these curves were obtained from the U. S. Geol. Survey, *Water Supply Paper 579*, p. 198, and subsequent monthly

nous coal mined. This does not include that used in the form of coke. If the two requirements were lumped together, the total would amount to 90,000,000 tons, or 18 per cent of the total.

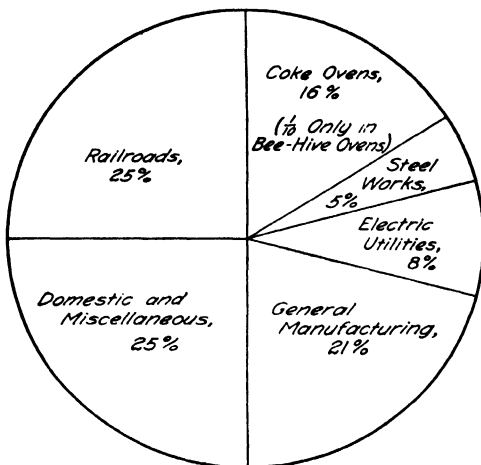

FIG. 10.—Uses of bituminous coal for a typical year of industrial activity—534,989,000 net tons in 1929.

There is small wonder that the pulse of business as recorded in the activities of the railroads and the iron and steel industry is so vitally felt by the producers of bituminous coal.

power reports. The data for the oil and gas-coal equivalent were obtained by subtracting the annual coal consumption from the value of the coal equivalent of all fuels given in *Elect. World*, p. 54, January, 1931. The curve *KWH* generated by coal is an approximation obtained by multiplying the values of the *KWH* generated by fuel by the corresponding ratio of coal consumed to coal equivalent of all fuel consumed. The values thus obtained were then subtracted from the corresponding values for the *KWH* generated by all fuels to obtain the values for the curve for *KWH* generated by oil and gas.

CHAPTER III

THE DEVELOPMENT OF FUEL RESEARCH

The scientific study of fuels in this country, while having an early start, has had also a very marked historical lag, possibly due to the almost extravagant supply of the material at hand. Conservation or any thought of research for the promotion of economy or high efficiencies had little consideration 100 years ago. The salient feature of such early studies as were undertaken is the fact that they were of a simple character and were concerned almost entirely with the question of relative values. Even so, they were naturally the direct reflection of the industrial development and needs of the time.

Marcus Bull.—It is believed that the first published information relating to fuel research in America is conveyed by the following reference: Professor Benjamin Silliman, in his *American Journal of Science*, has a notation which reads as follows:¹

I have just been favoured with a copy of a memoir by Mr. Marcus Bull, read before the American Philosophical Society of Philadelphia, April 7th, 1826, entitled "Experiments to determine the comparative quantities of Heat, evolved in the combustion of the principal varieties of wood and coal used in the United States for Fuel, and also to determine the comparative quantities of Heat lost by the ordinary apparatus made use of for their combustion." It is replete with interesting information and is to be regarded as one of the most important contributions of science to the arts and to domestic economy which has been made for a long time in this country. It is worthy of being carefully studied, both by scientific and practical men, and for the sake of the latter class, it might be well if an analysis of this elaborate and detailed paper, presenting in a lucid and concise form the practical important results which have been obtained by Mr. Bull . . . were prepared for extensive circulation.

That this suggestion of Professor Silliman was taken seriously and a method employed for carrying it out may be inferred from

¹ *Silliman's Jour.*, vol. 11, p. 98, 1826.

another publication in which all of the original tables are reproduced and which, incidentally, illustrates the meager channels for disseminating wisdom in those days. The manner is well set forth in the title page shown in Fig. 11.

The tables referred to are taken from the original paper as prepared by Mr. Bull. They were still live matter 17 years after their first appearance—at least live enough to be embodied in a family almanac. They occupy four pages of closely printed matter, giving values for 50 different sorts of fuel by percentage comparison with a single well-known standard type. Certain columns of the tables bear the heading: “Scale of prices: In each column of which the prices as they correspond with the standard, are in the same ratio with their respective powers of emitting heat.”

And so, through the medium of the family almanac there was carried out the suggestion of Professor Silliman that the results of Mr. Bull's investigations be given extensive circulation.

Turning again to the paper read before the American Philosophical Society in 1826, if we scan the very elaborate title to Mr. Bull's paper as quoted by Professor Silliman, we shall find that its 47 words can be narrowed down to five—“What Fuel, and How Efficient?”—a question even more pertinent now than it was 100 years ago.

With respect to his apparatus, Mr. Bull ventured a criticism on the calorimetric methods of Count Rumford, then but recently promulgated, and he proceeded to design what was in reality a calorimeter, even though it was in the form of a small insulated room in which a given weight of fuel was burned in such a manner as to maintain a fixed temperature for a measured length of time. A series of ratios was thus obtained between an accepted standard of reference and a fuel under observation. This early device used for calorimetric measurements is shown in Fig. 12.

After some preliminary trials and some fundamental suggestions by Robert Hare, professor of chemistry in the University of Pennsylvania, resulting in a much improved apparatus, the experiments, it must be admitted, produced at least comparative values of a reasonable degree of reliability.

Another point of interest in this connection is the standard fuel selected as a basis of reference. We are obliged to assume that

THE
 UNITED STATES
F U E L
 ALMANAC,
 FOR
1 8 4 3,

Being the Third after Bissextile, or Leap Year; and, until July 4th
 the 67th Year of American Independence.

CONTAINING TABLES TO DETERMINE THE COMPARATIVE VALUE
 OF THE DIFFERENT KINDS OF FUEL COMMONLY USED IN THE
 UNITED STATES, AND ALSO IN EUROPE: TOGETHER WITH A
 FEW DESULTORY REMARKS UPON THE DIFFERENT SUBJECTS
 CONNECTED WITH THE USE OF FUEL, CONSTRUCTION OF HEAT-
 ING APPARATUS, VENTILATION, etc.

BY ALMOND D. FISK.

Also, several instructions in
 Cookery, and illustrative



directions in Carving, by a
 person of experience.

NEW YORK:

PUBLISHED BY ROBERT H. ELTON,

98 Nassau st., and for sale at the principal Bookstores, and also at
 209 WATER STREET.

FIG. 11.—Title page of early "United States Fuel Almanac."

such a standard would be selected primarily because of its familiarity to all fuel users as well as for its constancy of behavior. The standard fuel thus selected by Mr. Bull was shell-bark hickory wood. In his brief survey of the fuel situation we are particularly

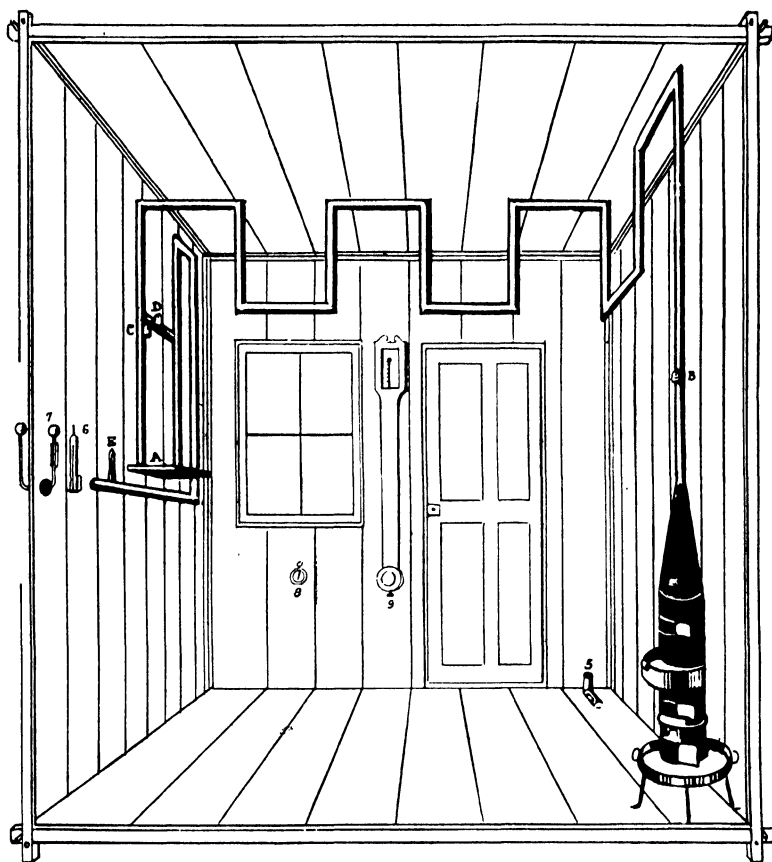

FIG. 12.—Early calorimetric device used by Marcus Bull in his experiments on fuel.

interested in the fact that the statistical data show that the annual consumption of fuel by the City of Philadelphia amounted to the equivalent of 173,000 tons, of which 140,000 tons were cord wood, 5,000 tons charcoal, 25,000 tons anthracite and 3,000 tons soft coal.

But the ultimate object of Mr. Bull's investigation seems intended to show not only that, with shell-bark hickory at 100 per cent, soft maple, chestnut, elm and similar woods were given a rank of from 56 to 58 per cent, but also that, on the score of efficiency, anthracite coal was the equal of the best wood obtainable. To quote from his introduction:

If we look prospectively to the early period when these coals [Lehigh or Schuylkill] may be expected to be furnished at \$5.00 per ton, their substitution for other kinds of fuel, in all cases where it is practical will become a matter of general interest . . . This portion [the eastern part] of the United States will, it is presumed, at no very distant period of time be principally supplied with fuel from the coal mines of Pennsylvania and, at an estimate of one-half the required quantity, will consume one and one-half million tons annually which, at \$5.00 per ton will amount to \$7,500,000.

While he was here confining his estimates to the Atlantic seaboard, we have already indicated that the total annual fuel bill for the entire United States at the present time, 100 years after, is in excess of \$5,000,000,000.

Walter R. Johnson.—Another reference of an historical character should be made as indicating the leisurely manner in which coal studies were developed in this country. A very remarkable but very little known investigation was published in 1844 by Walter R. Johnson, entitled: "A Report to the Navy Department of the United States on American Coals applicable to Steam Navigation and to other Purposes."

This report constituted a book of 606 pages and gave in detail the data connected with complete evaporative tests on 43 samples, three of which were shipments from England, Scotland and Nova Scotia, and one an American wood.

In setting forth the results, two hundred tables were required which, for the most part were double page in size. In one of these tables, Johnson, following a propensity characterizing many of the tables, puts his results in the form of a ratio and in this particular table, the coals tested are arranged in the order of the ratios of the fixed carbon to the volatile matter, and this ratio is shown to have a constant relation to the evaporative power of the fuels tested. Here it will be seen at once originated the term "fuel ratio," which in a general way serves as an index of coal values even at the present time.

One cannot go through the pages of this report without marveling at the indefatigable energy that must have characterized the author, the skill with which he developed a technic along lines having no established precedents to follow, and the wisdom with which he arranged and interpreted his results.¹

The St. Louis Coal Tests.—One other historical reference should be cited. In connection with the St. Louis Exposition of 1904, there was inaugurated by the United States Government an elaborate series of experiments which involved extended evaporative tests and resulted in an imposing array of analytical values, both proximate and ultimate, including also calorific values both calculated and determined, still having as the dominant idea throughout the determination of *relative fuel values* only.²

The Bureau of Mines.—The fuel venture of the St. Louis Exposition in 1904 served one good purpose at least. It developed an appreciation of the need for more profound studies in that line, and so, out of it all has grown the research laboratory of the Bureau of Mines at Pittsburgh, which has been pioneering in studies of a more complex and fundamental type and along lines which are already represented by a fair array of investigators elsewhere. Not a few of these investigators are centering their efforts on problems relating to the processing of coal, which has for its fundamental idea the segregating of values hidden in the complex chemical structure of the coal in such a manner as shall yield specific values or conserve values now lost in the present crude methods of generating heat, especially in household appliances, and, above all, producing a fuel for household use that shall be smokeless in combustion, thus eliminating the greatest contribution to the smoke nuisance that now exists. This objective, with its freedom from dirt and grime, and its potential contribution to health, must unquestionably characterize the second century of investigational work on fuels upon which we are now entering.

¹ PARR, S. W., A pioneer investigator: *Ind. Eng. Chem.*, vol. 18, p. 94, 1926.

² BRECKINRIDGE, L. P., A study of four hundred tests made at the fuel-testing plant, St. Louis, Mo., in 1904, 1905 and 1906: U. S. Geol. Survey, *Bull.* 325, 1907.

CHAPTER IV

CALORIMETRY IN AMERICA

It will not escape observation that I have placed the *management of fire* among the very first subjects of useful improvement.—RUMFORD, 1799. (Prospectus for organizing the Royal Institution of Great Britain.)

There is one other phase of the development of scientific methods for the study of fuels which has a historical background of more than passing interest. That development relates to the working out of methods for the correct determination of the energy content of fuels, that is, the measure of their heat units or calorific value.

Count Rumford.—Calorimetry came very near being born in America.¹ If one were to burnish up some of the odd corners connected with the Revolutionary period of American History, there is one of more than passing interest in connection with the development of the field of technical science. It would run somewhat as follows:

On the 26th of March, 1753, at North Woburn, near Boston, Massachusetts, was born Benjamin Thompson. As a young man his zeal for knowledge may be inferred from his daily journey of eighteen miles, on foot, in order to attend lectures at Harvard College.

In 1772, at the age of nineteen he was commissioned by Governor Wentworth a major in the Second Provincial Regiment of New Hampshire. The enmities and accusations that followed this appointment, growing into a serious threat against his life in 1774, caused him to embark for England, in October, 1775.

In England his investigational opportunities were greatly extended. Some of his experiments, especially in connection with gunpowder, were communicated to the president of the Royal Society. As a result of this and other scientific accom-

¹ PARR, S. W., *Calorimetry in America: Instruments*, vol. 3, p. 71, 1930.

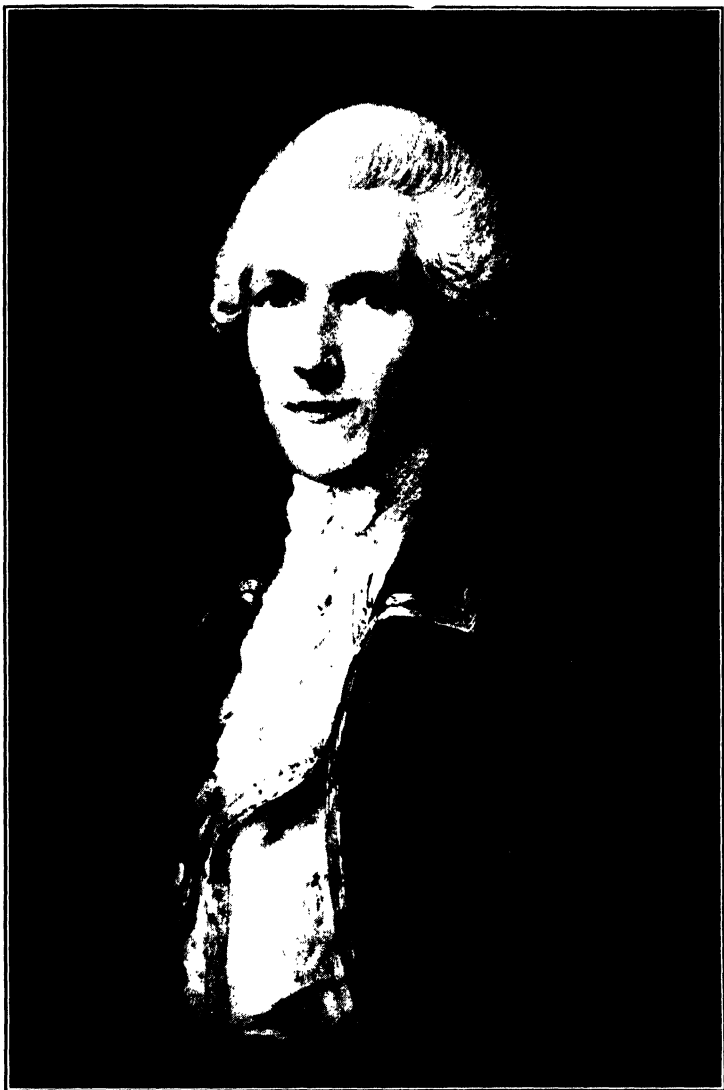

BENJAMIN THOMPSON, COUNT RUMFORD (BY GAINSBOROUGH)

plishments, he was made a fellow of that society in 1779. In 1784 he was appointed by the Elector of Bavaria to a combined military and civil position at Munich, where he established notable reforms growing directly out of his scientific studies relating to the properties of heat and their correct application in the preparation of food.

In this same year he was knighted by the King of England, George III, and upon his return to Bavaria was given the rank of count. He chose for his title that of "Count Rumford," honoring in this way the town of Rumford, later Concord, New Hampshire, where he spent the most active years of his life in America. It will take us too far afield to follow the subsequent career of Count Rumford. Any one desirous of details will find most interesting accounts of his life by Professor Tyndall, delivered as lecturer in 1883, "On Count Rumford, Originator of the Royal Institution." Aside from his remarkable accomplishments in the adaptation of scientific facts to problems of everyday living, his most notable achievements along scientific lines were as follows:

He was the originator of the formal generalization known as "the mechanical theory of heat," based on experiments conducted on a scale unexampled at the time, whereby he was able to prove that heat was a form of motion.

He was elected to the "Institute of France," in 1803, and lectured before its classes on subjects engaging his attention while a resident of France. He lived near Paris from 1808 to 1814, and "on February 24th, 1812, he brought before his class in the Institute some further inquiries concerning heat, with a description of his Calorimeter."

Cuvier, the permanent secretary of the Institute, in his eulogy at the time of Count Rumford's death in 1814, refers to his career in Bavaria, with its noble services and its high honors, and does justice to his genius in science and traces his devoted and eminently successful labors for ends of public utility and benevolence, especial reference being made to his scientific occupations after he had taken up his residence in France. Quoting directly from Cuvier's *éloge*,¹

¹ ELLIS, G. E., "The Life of Rumford," p. 617: Estes & Stuart Co., Boston.

He has constructed two singularly ingenious instruments of his own contrivance. One is a new calorimeter for measuring the amount of heat produced by the combustion of any substance. It is a receptacle containing a given quantity of water, through which passes, by a serpentine tube, the product of the combustion, and the heat that is generated is transmitted through the water which, being raised by a fixed number of degrees, serves as the basis of the calculations. The manner in which the exterior heat is prevented from affecting the experiment is very simple and very ingenious. He begins the operation at a certain number of degrees below this outside heat and terminates it at the same number of degrees above it. The external air takes back during the second half of the experiment exactly what it gave up during the first.

Rumford founded certain prizes and bequests—a prize to be awarded not oftener than once in two years by the Royal Society of London, to persons achieving notable results in the study of heat and light, “the preference always being given to such discoveries as shall, in the opinion of the President and Council, tend most to promote the good of mankind.”

A duplicate award with precisely the same wording was made to the Academy of Arts and Sciences of America, under date of July 12, 1796. This award was greatly appreciated by the academy:

The members of the Academy regarded it as the most helpful and encouraging recognition which their Institution had received during the sixteen years of its existence.

Count Rumford had been elected an honorary member of the Academy in 1789.

Count Rumford bequeathed the residue of his estate to Harvard College for the purpose of founding a professorship, the holder of which should

teach by regular courses, of academical and public lectures, accompanied with proper experiments, the utility of the physical and mathematical sciences for the improvement of the useful arts, and for the extension of the industry, prosperity, happiness and well-being of society.

Jacob Bigelow was appointed to the first Rumford Professorship. His inaugural address was on “The Life and Works of Count Rumford.” In the concluding paragraph he says:

To the country of his birth Count Rumford has bequeathed his fortune and his fame . . . Let those who would depreciate our native genius remember that he was an American.

A volume of Dr. Bigelow's lectures delivered in connection with the Rumford Professorship was published in 1829, under the title "Elements of Technology," thus introducing the use of a word among us which now serves to express an entire system of education by new adaptation of methods to new uses.

It will be noticed in this brief reference to the activities of Count Rumford that omission has been made of that part of his career which was of a political or social and not of a scientific nature. This omission includes especially his relation to the Revolutionary period from 1775 to 1784, during part of which time he held an important commission in the British army in America. This action seems difficult to understand, especially in view of his subsequent generous attitude toward the United States and the bequests he made to certain institutions in this country. A partial explanation may perhaps be afforded by the suggestion that he had a consuming zeal for the promotion of scientific information as the positive medium for the advancement of human welfare. His opportunity for scientific exploration in England may have convinced him that through that governmental medium the cause of scientific advancement could be more surely expedited, and that the restoration of the colonies to the British Crown would be in line with the greatest ultimate good. This indeed may have appealed to him as the highest type of patriotism for both countries. He seemed willing to subordinate every human relationship to the one end of promoting scientific accomplishment.¹

Fifty years after his inaugural at Harvard, Dr. Bigelow delivered the opening address at the inauguration of the

¹ It is evident that Count Rumford regained positive good will for the new republic. In 1779 (Ellis, *op. cit.*, p. 354) he was offered important political appointments in the United States where his scientific attainments were especially desired. These he was obliged to decline because of existing obligations in Europe and his activities in organizing The Royal Institution of Great Britain, in 1800, where the budding genius of Faraday soon after found fertile soil. The endowment resulting in the Rumford medal in America has become an outstanding honor, awards having been made to both Edison and Michelson.

Massachusetts Institute of Technology, Nov. 16, 1865, thus initiating a movement in the educational field, the significance of which at that time or the importance of which even now can scarcely be realized. We may therefore credit Count Rumford directly with the establishment in this country of "technical education."

This brief historical circuit brings us around with ample justification for the somewhat detailed reference to Count Rumford, to our initial statement that "calorimetry came very near being born in America."

Other attempts had been made to measure heat quantitatively but they were crude in type and incorrect in principle, judged by our present-day knowledge. It is to be noted particularly therefore that Rumford developed a calorimeter which, for the first time, embodied the principles which are now recognized as fundamental in such an apparatus. He burned a known weight of fuel in such a manner as to transfer the heat produced to a known weight of water, thus establishing two units of reference which made it possible to express the heat value of a combustible substance in units of standard and known terms. He calculated his values to the number of kilos of water that a unit kilo of fuel would raise through one degree. This was for many years the method of expressing calorimetric values. The method now more uniformly used gives the same value but is expressed in the degrees' rise of temperature which one kilo of fuel will impart to one kilo of water.

Nevertheless, the apparatus of Count Rumford was not without its critics. Marcus Bull was one of those who found fault with Rumford's method, claiming that what was desired in a fuel calorimeter was some system which would give directly the relative values of different fuels used in the arts or for domestic purposes. He claimed to have devised an apparatus which furnished such values. A description of his outfit has already been given. It consisted of a detached and insulated room, 8 by 8 by 8 ft., in which an attendant kept up a fire in a small heater in such a manner as to maintain a given temperature for a definite length of time, and the weight of the various fuels thus tested furnished a series of ratios when referred to a given fuel selected as a standard of reference.

Mr. Bull's method would seem to be rather crude, but it is of decided importance to note that this method of developing ratios has possibilities of extreme exactness, being limited of course by the degree of uniformity as to the conditions under which the several tests could be conducted.

The Atwater Calorimeter.—The next outstanding investigation in America was made by Professor W. O. Atwater, at Wesleyan University, Middletown, Conn., who may have taken some remote hint from Bull's experiments through there is nothing in the literature to suggest that idea. At any rate he developed his respiratory or human calorimeter along somewhat similar lines, building a room so well insulated that the heat input in the way of food could be definitely measured in heat units, and the output by the human system similarly measured in temperature rise.

While this life-sized calorimeter was a great accomplishment in itself, it can readily be seen that its use and value would depend directly upon the theoretical or exactly determined heat value of the food supplied to the subject within the large apparatus. This led Professor Atwater to devise a calorimeter, along the lines proposed, at about the same time by Mahler, and somewhat earlier by Berthelot, of France. Atwater's instrument¹ consisted of a steel bomb, lined with platinum and capable of retaining oxygen under a high pressure of 25 to 50 atmospheres, with provision for igniting the food sample by electric contact through the cover of the bomb. The bomb was submerged in a known weight of water held by a round can or vessel of pewter.

It will be seen that we have here a departure from the method used by Rumford, whose experiments were conducted at constant pressure, since, in Atwater's system the combustion is carried on at constant volume.

It is not our purpose to follow the developments in detail along these two lines. Rumford's followers were: Dulong (1838), who substituted oxygen for air; Favre and Silbermann (1852), who introduced numerous mechanical improvements; and Fischer, who went still further by constructing his combustion chamber of silver. All of these devices, even of the pure oxygen type operat-

¹ ATWATER, W. O., and WOODS, C. D., A new form of bomb-calorimeter *Rept. Storrs (Conn.) Expt. Sta. for 1894*, p. 135; see also ATWATER and SNELL, *Jour. Am. Chem. Soc.*, vol. 25, p. 659, 1903.

ing at atmospheric pressure, encountered serious difficulties when used with coals of high ash content on account of incrustation which prevented complete combustion of the charge. The constant-volume type came chiefly as a relief from the difficulty of incomplete combustion and has been further promoted in popularity by the ease with which oxygen in high-compression cylinders can be obtained.

The development of high-compression or constant-volume calorimeters was brought about by Berthelot in 1881. About 10 years later (1892), Mahler proposed a cheaper construction by using a bomb having an enamel lining. It was at this time, contemporaneous with Mahler's work, that Atwater developed his instrument as an adjunct to his respiratory calorimeter. His bomb, while equipped with a spun lining of platinum and a platinum-lined cover, had substantially all the present-day conveniences of manipulation, including of course the use of high-pressure cylinders of oxygen for filling the bomb.

The Parr Calorimeters.—A further advance in calorimetric apparatus has been made as a result of investigational activity in America. This apparatus seeks to avoid the expense of a platinum lining and also the objectionable features of an enameled surface with its liability to cracking and consequent exposure of the metal to corrosion from the mixed sulfuric and nitric acids which accompany the combustion, especially of high-sulfur coals. Following the Berthelot type of bomb as improved in pattern by Atwater and eliminating the use of a platinum lining as employed by both of those investigators, there was developed in the author's laboratory a special acid-resisting alloy for use in the construction of calorimeter bombs.¹

Another radical departure in the method of determining the calorific value of fuels was also devised in 1899.² The method proposed made use of the oxidizing power of sodium peroxide. The products of combustion being CO₂ and H₂O were at once

¹ PARR, S. W., A new alloy with acid resisting properties. Original communications, 8th Internat. Cong. Applied Chem., vol. 2, p. 209, 1912. A new calorimeter bomb, with special advantages as to material of construction and method of operation: *ibid.*, vol. 1, p. 389.

² PARR, S. W., A new coal calorimeter: *Jour. Am. Chem. Soc.*, vol. 22, p. 646, 1900.

incorporated as solid constituents by the chemical employed, so that no pressure of escaping gases had to be taken care of. The heat of the reaction was sufficient to convert the entire charge into a fused mass, thereby making it possible to use a container of relatively small proportions and of such compact form that it could be made to revolve upon its own axis, thus furnishing the mechanical means for stirring the surrounding water throughout the period of the test. The reactions involved have been found to be exceedingly constant in behavior and have been shown to serve as an excellent medium for measuring the calorific value more especially of hydrocarbon fuels such as coals of all types and oil.¹

The description of these instruments and the methods for their use are given in Part II of this volume.

¹ PARR, S. W., *Calorimetry in America: Instruments*, vol. 3, p. 71, 1930.

CHAPTER V

THE CONSTITUTION OF COAL

Introduction.—The development of the methods for fuel investigation has been slow and at first was almost entirely confined to analytical methods of some type. Johnson for example, in addition to his evaporative tests, made excellent determinations, it must be said, of moisture and ash as well as of carbon, hydrogen and oxygen, but there were no calorimetric instruments available and he arrived at those factors indirectly by calculation. Indeed, there were no satisfactory instruments for such determinations until 35 years after Johnson's experiments of 1844. The analytical data which had developed meanwhile represented about all of the investigational activity of 50 or even 30 years ago, and these were exceedingly meager and mostly of doubtful reliability.

A new period of fuel investigation has, however, been rapidly coming forward. In the field of combustion, for example, the power engineer has made notable advances in the matter of smoke abatement and higher efficiencies.

By the application of comparatively simple mechanical devices, coupled with the uniform and high temperatures with which he deals, it is evident that the problem of the engineer has been relatively an easy one, and he has made very little appeal to the chemist for help. But the investigators from the purely chemical side have not been idle. Indeed, it will be entirely correct to say that, as we enter upon the second hundred years of fuel study, it is characterized by the number of workers who are studying fuel problems from the fundamental rather than the empirical standpoint.

Thus it has come about that in our new century of coal investigation the question of fuels of an improved type, with sanitary as well as economic factors, comfort, convenience, cleanliness and efficiency must receive consideration. The outstanding feature is the fact that in these studies, from a chemical standpoint especially, an altogether revolutionary method of procedure has been inaugurated.

It has long been recognized that the ordinary methods of analysis were inadequate for supplying more than the most meager information and that, confined almost wholly to specific needs of a few industries. The power plant has wanted to know how much ash and water it was paying for, and the gas manufacturer has wanted to know the yield in terms of cubic feet per ton of raw material employed. The so-called method of proximate analysis grew out of the needs of the power plant. It can give but very meager information of value in other fields.

But meager as this information is, it surpasses that furnished by the so-called ultimate analysis. The proximate method, moreover, is the one almost exclusively used in this country, whereas the ultimate is used in England and on the Continent. The American therefore feels handicapped when he is unable to find data on English coals except in terms of ultimate values and undoubtedly the Englishman is equally disconcerted when he finds nearly everything about American coals in terms of proximate factors.

These are only sample references to the many indictments that might be cited against the old investigational mechanism relating to fuels which we have inherited from the past. It has been stated, however, that really revolutionary methods of procedure have in recent years come into vogue. This fact is seen to have striking confirmation in the case of a bibliography recently compiled under the topic of the "Constitution of Coals," which lists five hundred different references to published articles in the literature.

This may be interpreted to mean that many investigators are at work in this field, which is true. It might also be interpreted to mean that we must know a lot about the subject, which is not true. It is rather an index of how little we know. It at least suggests that the subject is intricate, involved, difficult, many-sided, complex and not solvable by the ordinary processes of simple analytical procedure, all of which is undeniably and emphatically true.¹

Coal Structure.—In the Twentieth Annual Coal Report of the Illinois Bureau of Labor Statistics (1902), there is included a section on the Chemical Analysis and Heating value of Illinois Coals.² This report, the first of its kind relating to Illinois coals, is here referred to as furnishing a fair index of the development of fuel studies at the time. There were presented in tabular

¹ PARR, S. W., The constitution of coal: The Chandler Lecture, Columbia University Press, 1926.

² PARR, S. W., and KOCH, F. C., Chemical composition of Illinois Coals: 20th Ann. *Coal Rept.*, Ill. Bur. Labor Statistics, 1902.

form all of the results obtained from chemical analyses at the University of Illinois since the year 1878. The tables "included also results from other sources so far as they were accessible and seemed to be reliable." The table headings indicated that they "comprised 260 analyses from ninety-four different locations."

If a similar compilation had been made at that time from the three other main coal-producing states, Pennsylvania, West Virginia and Ohio, it is doubtful if the total list of samples analyzed would have exceeded 500 or 600 in number. If a separate count were made for the samples that had been submitted to ultimate analysis, it is doubtful if the count would exceed 50, and even for that number it would be necessary to go back far enough—to 1844 to include the 43 results of Johnson, and a few more from the Rogers report for Pennsylvania, published in 1858.¹

Since the year 1900 and mainly as a result of the inauguration of the work of the fuel testing plant at the St. Louis Exposition of 1904, followed by the establishment of the U. S. Bureau of Mines Laboratories at Pittsburgh in 1907 the analytical results, both proximate and ultimate, from that source alone have exceeded 12,000 in number. The work of private laboratories, if published and made similarly available, would far exceed that amount. The Commercial Testing and Engineering Laboratory of Chicago, for example, estimates its total samples analyzed in the last 20 years as being in excess of 50,000.

But the results thus obtained have been mainly for technical or commercial purposes. During this same period there have been in process of development many studies of a fundamental character, the results of which and their value in many industrial as well as scientific phases are only now coming to be realized. Some of these lines of research, now more properly referred to as studies on the *constitution of coal*, are given brief reference as follows:

Probably the most outstanding study on the constitution of coal has been carried on by Dr. Reinhardt Thiessen, of the U. S. Bureau of Mines, in his microscopical studies beginning with the

¹ ROGERS, H. D., "The Geology of Pennsylvania," J. B. Lippincott Company, Philadelphia, 1858.

transformation which takes place in present-day peat bogs and extended on through all stages of bituminous coals. Professor Turner, of Lehigh University, has carried these studies into the anthracite field so that we can now say that every stage of coal formation, from peat to anthracite, can be made to reveal its initial plant structure and the type of vegetable matter that has entered into its composition. Some of the main features pertaining to these studies are here given.

Coal Bands.—It is probable that all coal beds are made up of layers. As a rule these are clearly seen as shown in Fig. 13. These layers are of three types which differ radically from each

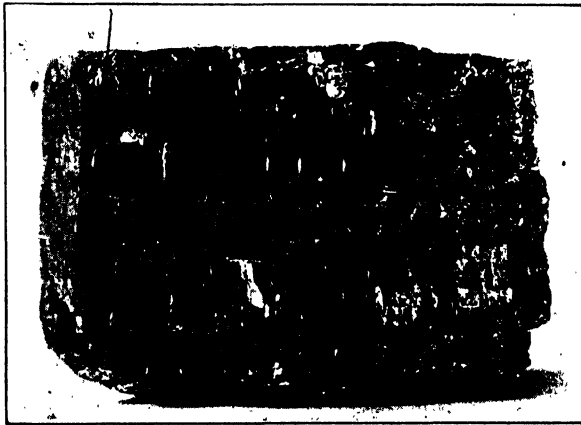

FIG. 13.—Bright and dull bands in Illinois coals.

other. First there is the bright, glistening band commonly referred to as “glanz-coal.” This is the band of uniform structure showing dark in the picture. Second, there is the so called “dull band” showing an admixture of light and dark material, giving a grayish effect. The reflection of light in patches from the surfaces of the cleavage planes should not be confused with the horizontal bands which make up the bedding layers. A third band, which is seldom visible at the edges of the bedding planes, may often be seen along the surface of the planes upon breaking a lump of coal horizontally. It is usually of paper thickness and dust-like, soiling the fingers when touched. This is the so called “mother of coal.”

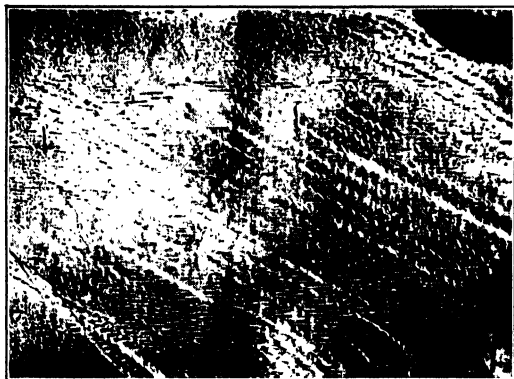

FIG. 14.—Anthraxylon or woody cell structure, in bituminous coal, Royalton Mine, Illinois. ($\times 200$.) (By *Thiessen*.)

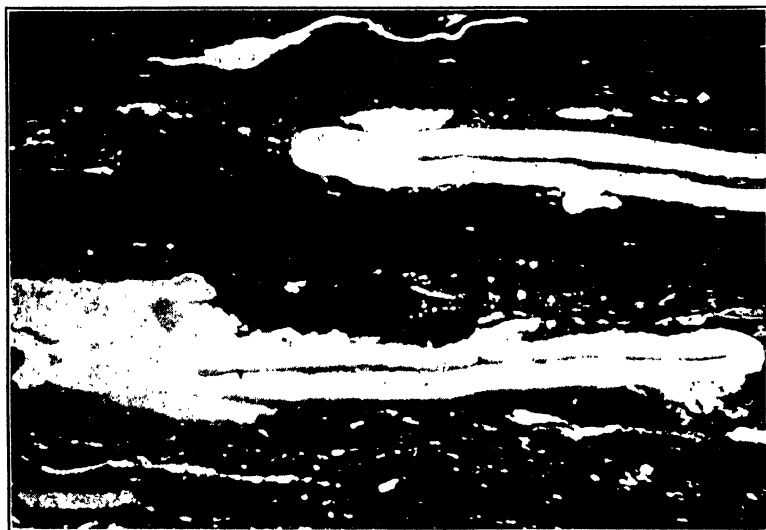

FIG. 15.—Attritus in bituminous coal, showing mostly spore residues. (By *Thiessen*.)

Microscopical Study of Coal.—In Dr. Thiessen's work¹ a section of clear glanz-coal was reduced to a degree of thinness that would permit of the transmission of light, which then showed a perfect cell structure, as seen in Fig. 14. This is clearly a residual material from wood only, and Dr. Thiessen has given it the name "anthraxylon." By treating a portion of the dull bands in the same manner, we find a conglomerate which may contain minute interwoven or embedded streaks of anthraxylon, and a mixture of spores, spore cases or cuticles, leaves, bark,

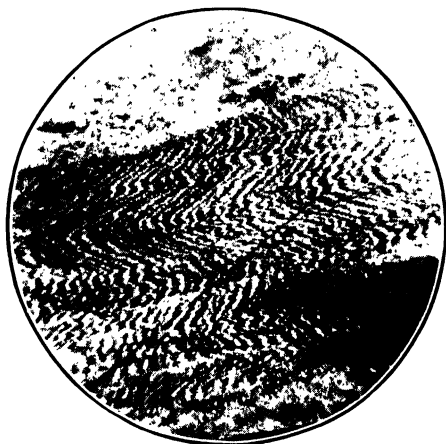

FIG. 16.—Anthraxylon in anthracite coal. ($\times 34$.) (By Turner.)

needles and all possible forms of vegetable residues, to which the name of "atritus" has been given. Some of these residual forms may be clearly seen in Fig. 15 wherein spores predominate. These forms, of course, are flattened out but are characterized by a streak through or along the central axis, suggesting an original hollow space or a zone of different texture which has become flattened horizontally by extreme pressure. The third layer, formerly known as mother of coal or mineral charcoal, has been given the name of "fusain."

In Professor Turner's study of anthracites² precisely these same structural forms are found. As may be seen in Fig. 16, of

¹ THIESSEN, REINHARDT, Structure of paleozoic bituminous coals: U. S. Bur. Mines, *Bull.* 117, 1920.

² TURNER, H. G., Am. Inst. Mining Met. Eng., *Tech. Pub.* 234, 1929.

anthraxylon, and in Fig. 17, where plant spores are clearly shown, we have evidence of a banding structure comparable to that found in coals of the bituminous type.

It is not our purpose here to go into the methods whereby these microstructures have been revealed. Reference can only be made to publications of the U. S. Bureau of Mines and of Lehigh University, where detailed accounts of these various structures may be found.



FIG. 17.—Details of dull bands, or attritus, in anthracite. Note large spores at *a* and *b*. ($\times 34$.) (*By Turner.*)

Significance of Constituents.—The general properties of these three types of banded material are of extreme importance. The anthraxylon, for example, is of lower specific gravity and has substantially only the ash content of the pure wood structure of the original tree body. During the geological processes, which include bacterial action, transformations due to intense pressure, some probable increase in temperature and the element of time, there has been a complete elimination of cellulose so that, either due partly to some residual decomposition product of the cellulose or partly to material contributed from changes in the lignins or protoplasmic material, there has been developed in the anthraxylon more or less of a substance which is bituminic in character. This material is characterized by being soluble in

such media as phenol, xylene and pyridine. It has also a definite melting point and is the chief constituent upon which depends the coking property of coal. It has therefore the higher percentage of the coking constituent.

The dull bands of attritus, as may be readily understood, have accumulated extraneous mineral matter in the process of sedimentation so that its ash content is high, far beyond that which would be accredited to the ash of the plants themselves. It has also the original resinous material, depending in amount upon the predominance or absence of spores in the original plant deposit. It may have slight agglutinating property, depending upon the amount of admixture of anthraxylon.

The mother of coal or fusain, although small in relative amount, is of very considerable importance in determining the character of the coal, especially in certain industrial relationships. In its normal state it is not coherent but powdery. For this reason it is often shown to have furnished the channels for the infiltration of water. Sometimes this infiltrating water is a saturated solution of some sort and may convert the soft, friable material into a dense layer composed for the most part of mineral matter, sometimes of calcium carbonate and usually containing more or less iron pyrites. Furthermore, under any conditions, it has no agglutinating power and is doubtless responsible for the fine colloidal dust that accompanies the handling of most types of bituminous coals.

It is well to note the corresponding names for the same types as adopted by English investigators and originally proposed by Stopes and Wheeler.¹ The anthraxylon of Thiessen they designate as "clairain." His attritus they call "durain,"² and mother of coal or mineral charcoal they call "fusain." These English terms, with the exception of fusain, seem to be somewhat slow of adoption in this country.

¹ STOPES, MARIE C., and WHEELER, R. V., Monograph on constitution of coal: Dept. Sci. and Ind. Research, London, 1918; see also Thiessen, R., and Francis, Wilford, Terminology in coal research: U. S. Bur. Mines, *Tech. Paper* 446, 1929.

² The term durain, seems to be more applicable to the splint coals of England as well as America, and in his later studies it is so applied by Thiessen.

CHAPTER VI

THE CLASSIFICATION OF COAL

Introduction.—From the microscopical studies on the constitution of coal a great deal of information has been obtained concerning the initial vegetable types that have entered into the formation of coal and the effect they have had in imparting special characteristics to the final product. Any feature of classification, therefore, which would involve the recognition of coal types must make use of this fundamental information as to plant forms and vegetable make-up that has been revealed by the microscope.

As an illustration of what is meant by "coal types," an example would be "cannel coal," which is made up almost entirely of spore residues usually mixed with an undue amount of earthy substance. Such coals are very rich in resinous material, ignite easily, small splinters burning like a candle (cannel) and, as might be expected from the type of organic matter which predominates, they have little or no coking property.

Again the "splint coals," which occur in West Virginia, are shown by the microscope to be made up also chiefly of attritus, usually with a larger amount of earthy mixture and having widely varying amounts of interwoven anthraxylon. Their agglutinating property is low, largely dependent upon the amount of anthraxylon mixed in with the various plant residues.

Another viewpoint in developing a system of classification is based on the degree of metamorphism or coalification, *i.e.*, the age or rank, geologically considered, to which the deposit has attained in passing from the raw conglomerate of the peat bog to the final anthracitic or graphitic stage. This viewpoint, by reason of the more advanced stage of geological information, up to the present time has held a prominent place, and to a large extent has entered into most of the proposals for a method of coal classification. Unquestionably, however, chemical composition has been the leading and, indeed, the basic factor

throughout. This will be plainly evident upon the presentation of a résumé of the matter, especially as it has been in the process of development in different countries.

Historical.—In each coal-producing country a method of classification has come into vogue which is a direct development of the methods of study or of the trade requirements peculiar to the several coal-producing regions.

Regnault in France was probably the first chemist to make ultimate analyses of coal, and the Grüner system of classification utilized the values thus obtained, especially the percentages for carbon, hydrogen and oxygen. Regnault drew his conclusions as to type from the percentages of total carbon and also from the ratio of oxygen to hydrogen. Wedding in Germany put more stress on the percentage of volatile matter. In England, in the earliest conception as set forth in Ure's "Dictionary of Arts, Manufactures and Mines," (1846) under "pitcoal," and also in the older editions of Watt's "Dictionary of Chemistry," the terms used for designating different coals were not chemical but almost wholly derived from physical properties and industrial uses; hence the introduction of terms which still have a place in coal technology, such as cubical, cherry, caking, splint, non-caking, glanz, etc. In recent years Seyler has rescued the English coals from a terminology almost meaningless, at least to the foreigner, and inaugurated a scientific method based on chemical values.

In America the first suggestion of a basis for classification is found in the report of Professor Walter R. Johnson to the United States Navy, printed in 1844 as Senate Document 386, to which reference has already been made. His arrangement of the coals in the order of the ratios of the fixed carbon to the volatile matter was shown to have a constant relation to the evaporative power of the fuels tested. Here, it will at once be seen, originated the term "fuel ratio," which in a general way has served as an index of coal values.

It remained for Professor Persifer Frazer, however, to indicate the true significance of this ratio. Professor Frazer's paper in which he proposed a scheme of coal classification based on Johnson's idea of fuel ratios was read at the Wilkes-Barre meeting of the American Institute of Mining Engineers in 1877, and the terms there proposed have stood substantially unchanged to

the present time.¹ It is interesting to note in this connection that for the 25 years following the publication of Professor Frazer's paper studies on coal were very meager. In the next 25 years, as already noted, a very marked impetus in the matter of coal investigation is evident, so that at the present time a mass of data has accumulated which suggests the possibility of extending, or better perhaps of reconstructing, our basis for coal classification in a manner which would have been impossible in the earlier years.

It is not intended here to review in detail the discussions on coal classification which have been a marked characteristic of the literature of fuel technology. A long list of investigators have had access to and made excellent use of a mass of present-day analytical values and have presented the topic largely from the scientific standpoint. A discussion of the merits of these various propositions cannot be entered into here. A bibliographic list of 115 references which will be valuable to any one who wishes to study the development of the topic of classification may be found in *Bulletin* 180 of the University of Illinois Engineering Experiment Station.²

Fundamental Factors in Classification, Oxygen and Volatile Matter Content.—One need take only a superficial view of the coal studies in this and other countries to see that there are a few fundamental factors that seem to have been selected to carry most of the burden of determining the specific properties that differentiate the various coals from each other. Such factors derive their importance both because they impart specific properties to the coal and also because they indicate the stage of metamorphism to which the coal has attained.

This may be illustrated as follows: The original organic material entering into the coal deposit is lignitic and may be represented by the empirical formula for cellulose, $C_{12}H_{20}O_{10}$ —or better that for ligno-cellulose, $C_{12}H_{18}O_9$. Coalification is usually referred to as a process of carbonization, that is, a metamorphism whereby the percentage of carbon is increased. But the process is more

¹ FRAZER, PERSIFOR, JR., *Trans. Am. Inst. Mining Eng.*, vol. 6, p. 430, 1878.

² PARR, S. W., The classification of coal: Univ. Ill. Eng. Expt. Sta., *Bull.* 180, 1928.

involved. It is true that carbon concentration is effected by removing the oxygen, but the fact is important that oxygen reduction is not due to the loss of oxygen as O_2 , nor yet entirely to its loss in the form of H_2O , as might be inferred from the formula where the hydrogen and oxygen are present in the H_2O or water-forming ratio. As a matter of fact this element is given off during the geological processes in the form of oxides of carbon, as well as in the form of H_2O . Hence, for each molecule of CO_2 released, there has resulted not only what is equivalent to a concentrating of carbon but also the retainment of four atoms of hydrogen, which thus remain free from any oxygen with which they may combine, and become available for the production of heat in case of combustion of the material. Some of the hydrogen, of course, is lost as marsh gas (CH_4) during the first or fermentation stage of decomposition.

These conditions may be illustrated by an equation, using again empirical formulas as follows:

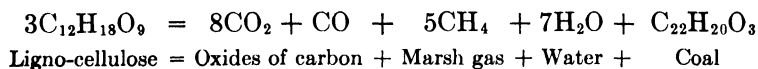

It is not to be inferred, of course, that the formula given for coal is intended to represent a definite compound but rather a complex lot of organic substances having a very large part of their composition made up of carbon, hydrogen and oxygen, in the relative amounts most readily indicated by such a formula. Similarly, the ligno-cellulose formula represents a complex organic combination of plant material in which the lignin and associated materials of the same general type predominate. These transformations with associated constituents in their relative proportions are represented in Table II. The percentage

TABLE II.—COAL FORMATION REPRESENTED BY MOLECULAR FORMULAS

Ligno-cellulose			=	bituminous coal			+	loss as O and C compounds		
$3C_{12}$	H_{18}	O_9	=	C_{22}	H_{20}	O_3	+	$8CO_2$	$+ CO$	$+ 5CH_4 + 7H_2O$
47 %	6 %	47 %		80 %	6 %	14 %				
918 wt., gram-mol.			=	332 wt., gram-mol.			+	586 wt., gram-mol.		

factors for each constituent element in the original substance and in the resulting complex are shown beneath the formulas. As a matter of fact, since the loss by pressure and heat largely consists

of oxygen, hydrogen and carbon, these geological alterations are in effect a method of carbonization and are clearly related to destructive distillation by heat whereby only fixed carbon remains. These relations are well illustrated in Fig. 18. Between the two stages of carbonization by heat and by geological processes is the volatile matter, and obviously it is the deciding factor which governs the character of the residuum of the geological changes.

Typical stages of transformation for coals of the three main types are illustrated in Fig. 19, where the shaded portions showing the type constituents for each coal represent the oxygen

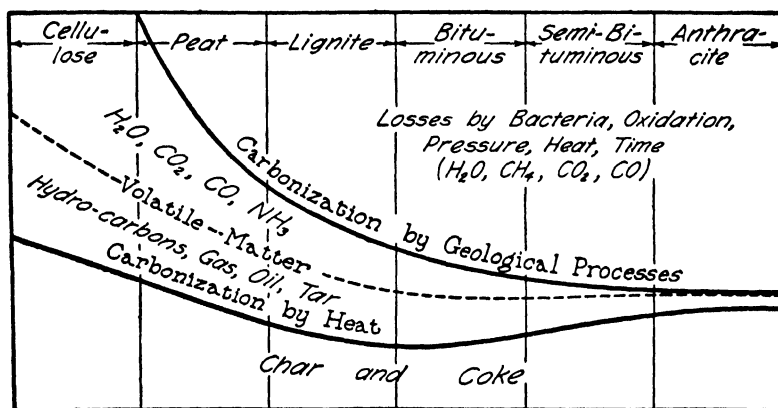

FIG. 18.—Decomposition stages of vegetal material.

portion which would be given off in combustion as inert material, mainly as the oxide of hydrogen, H₂O. This residual oxygen becomes of decided significance in its influence upon the character of the coal of which it is a part. Its presence is definitely related therefore to type, and the amount present in any given coal can be more precisely shown by its inert effect upon the calorific value of the pure coal substance of which it is a part.

This, in brief, is the underlying principle observed in the method of classification of coals here adopted, as will be obvious from the discussion which follows.

Since these oxygen compounds are already present in a saturated condition so far as heat of oxidation is concerned, they become in effect so much inert material. The obvious effect from the standpoint of classification, however, is that with higher

ANALYSIS OF LIGNITIC COALS

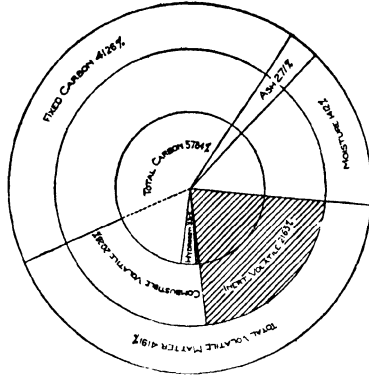

ANALYSIS OF A LIGNITIC OR BROWN COAL SHOWING CONSTITUENTS IN RELATIVE PROPORTIONS

ANALYSIS OF ILLINOIS COALS

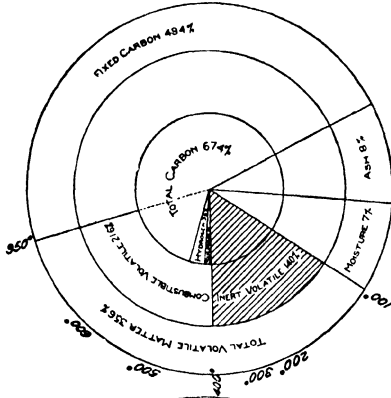

AVERAGE OF TEN ILLINOIS COALS SHOWING CONSTITUENTS IN RELATIVE PROPORTIONS

ANALYSIS OF EASTERN COALS

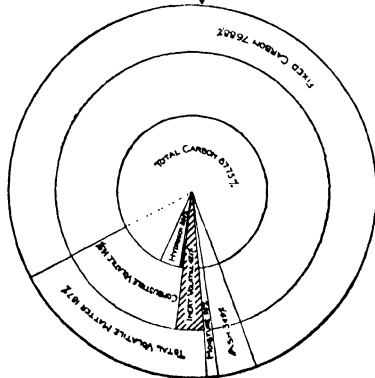

ANALYSIS OF A SEMI-BITUMINOUS COAL (POCAHONTAS) SHOWING CONSTITUENTS IN RELATIVE PROPORTIONS

Fig. 19.—Composition of coal types as shown by analyses.

or lower content of this constituent a decided difference in quality and character of the coal is found. Those fuels with the higher percentage of inert substance are in a less advanced stage of fuel development and in geological terms are referred to as the younger or more recent coals being located towards the left areas of Fig. 18.

It is evident from the foregoing, therefore, that both volatile matter and oxygen are vitally related to type and, since the presence of oxygen in higher or lower amounts will affect the calorific value, that constituent can most readily be given expression through the medium of the heating value. A converse statement can also be made which still further accentuates the part which the calorific value may be made to play in indicating type. The volatile constituents of fuel are almost entirely made up of combinations of carbon, hydrogen and oxygen. The more hydrogen there is available the higher will be the calorific value, and since low oxygen augments the amount of available hydrogen it is again seen that calorific value may be used as a direct index of type.

To use calorific values for purposes of classification involves certain specific and very fundamental considerations. It can be readily understood in the first place that all extraneous or adventitious matter must be eliminated so that the indicated calories may be made to relate definitely to the pure coal substance. Only by strict observance of that principle can variations in heat value be interpreted to mean variation in type. That is to say, only by reference to the pure or unit coal substance may the heat value be made an index of variations in the constitution or type of fuel. An increase of oxygen in the unit coal substance, since it is accompanied by a decrease of either the hydrogen or carbon or both, has a nullifying effect upon the calorific value of the unit coal substance, and *vice versa*, so that the interrelation of these elements and their effect upon calorific values when divorced from all extraneous material operate in a manner to serve as an index for variations in type.

Unit Coal.—Unit coal is the pure coal substance, considered altogether apart from extraneous or adventitious material which by accident or through natural causes may have become associated with the combustible organic substance of the coal.

It is evident from the methods of procedure used in arriving at analytical values that none of the processes employed will give directly the amount of pure fuel substance present in any given case. This is more evident in the case of ash determinations for coal. The ash, as weighed, is not an exact measure of the inorganic substance present in the original coal. Such items as the hydration of the shaly constituents, the presence of carbonates or sulfur, especially in the form of iron pyrites, should be looked upon as impurities and not allowed to enter into those considerations which are supposed to be based specifically upon the pure coal substance. In arriving therefore at correction factors which differentiate the pure coal substance from the non-coal substance, the following formula has been proposed:

$$\text{Non-coal} = M + A + \frac{5}{8}S + 0.08(A - \frac{1}{8}S)$$

in which

M is the fractional moisture.

A is the fractional ash as weighed.

S is the fractional sulfur.

$\frac{5}{8}S$ restores the Fe_2O_3 as weighed in the ash to FeS_2 , as weighed in the coal, 3 oxygens or 48 in the ash having been originally 4 sulfurs or 128 in the coal.

$\frac{1}{8}S$ represents the equivalent of Fe_2O_3 as weighed in the ash, that is, the Fe_2O_3 molecule, 160, is $\frac{1}{8}$ of the sulfur present in the coal.

$(A - \frac{1}{8}S)$ is the ash as weighed minus the Fe_2O_3 .

0.08 is a constant applied to the iron-free ash to restore the water of hydration to the earthy matter less iron pyrites, thus representing the true amount of shaly constituent as weighed in the original coal.

Where values are given on the dry basis, the M disappears and the formula becomes:

$$\text{Non-coal} = A + \frac{5}{8}S + 0.08(A - \frac{1}{8}S)$$

Simplifying this equation we have:

$$\text{Non-coal} = 1.08A + \frac{2\frac{1}{4}}{40}S$$

and in its final form the equation as used becomes:

$$\text{Non-coal} = 1.08A + \frac{2\frac{1}{2}}{40}S$$

Here the fraction $2\frac{1}{40}S$ has been changed slightly to $2\frac{2}{40}S$ or $0.55S$, as being in the direction of simplifying the calculation as well as promoting accuracy by compensating for the sulfur not in the pyritic form.

If the formula for the non-coal substance as given is a correct expression for that material then the pure or unit coal becomes:

$$\text{Unit coal} = 1.00 - (1.08A + 2\frac{2}{40}S)$$

which gives a basis of reference for the utilization of calorific values.

Unit B.T.U.—From the expression which has been developed in the preceding discussion for unit coal it follows obviously that the calorific value for unit coal, *i.e.*, the unit B.t.u., would be represented by the indicated heat value as derived by the calorimeter, divided by the unit coal factor, thus:

$$\text{Unit B.t.u.} = \frac{\text{dry B.t.u.} - 5,000S}{1.00 - (1.08A + 2\frac{2}{40}S)}$$

The factor $5,000S$ is used as indicating the resultant of the burning of the sulfur to SO_2 , and the iron to Fe_2O_3 . A detailed explanation for the factor as thus adopted is given in a note at the end of this chapter. The propriety of eliminating the heat of the sulfur is obvious from the purpose involved, *viz.*: to arrive at the heat value for the pure coal substance, free from all extraneous matter not basically involved in governing the type of organic material which enters into the constitution of the actual coal substance.

The development of the formulas presented representing the non-coal, the pure or unit coal and the unit B.t.u. is, in the main, based on theoretical considerations. The question naturally arises as to their correctness when put into actual use. Can verification of their value be demonstrated by empirical as well as by theoretical processes?

Evidence of Accuracy of Formula for Unit Coal.—Several methods for verification of the formula suggest themselves. Obviously, for a sample of coal with high ash or a high-ash sample obtained by use of the "sink-and-float" method of separation, the formula would give unfavorable results if the constant of 8 per cent as applied to the ash were wrong. If this factor is correct then, so far as ash variations are concerned, the B.t.u. values for unit coal as calculated should be substantially

the same for the same coal, no matter what the ash content. Similarly, the sulfur corrections when applied to wide variations in sulfur in the same sample or in samples from the same mine should not produce a divergence in the thermal values when calculated to the unit basis. A great mass of data has been accumulated from which only a limited number of illustrations

TABLE III.—COMPARISON OF UNIT COAL VALUES ON FLOAT AND SINK DIVISIONS OF SAME SAMPLES

Description	Water	Ash	Sulfur	B.t.u.		Variation from float sample value	
				As determined on float and sink samples	As calculated to unit coal		
1 Illinois Grundy County	{ Float	0.00	4.57	1.44	13 475	14 217	+45
	{ Sink	0.00	21.99	5.00	10 735	14 262	
2 Illinois Williamson County	{ Float	0.00	4.34	1.07	13 970	14 690	-23
	{ Sink	0.00	18.28	1.37	11 731	14 667	
3 Indiana Vigo County	{ Float	0.00	4.27	3.08	13 870	14 638	+60
	{ Natural	0.00	16.84	7.62	11 790	14 698	
4 South Africa	{ Float	1.63	6.06	1.38	13 703	15 065	+28
	{ Sink	1.66	18.94	2.28	11 680	15 093	
5 South Africa	{ Float	2.07	8.88	0.87	12 989	14 779	+20
	{ Sink	1.82	15.24	1.80	11 847	14 799	
6 South America	{ Float	5.97	17.24	0.68	10 602	14 127	+35
	{ Sink	3.59	49.25	2.58	5 922	14 162	
7 Alabama-Pratt Seam Walker County	{ Float	1.20	4.40	0.85	14 384	15 371	-1
	{ Sink	1.00	16.14	0.83	12 467	15 370	
8 Ala. Mary-Lee Seam Jefferson County	{ Float	1.04	9.78	0.99	13 683	15 576	+44
	{ Sink	0.92	23.70	1.23	11 246	15 620	
9 West Virginia Bituminous	{ Float	1.20	3.40	0.60	14 616	15 416	+27
	{ Sink	1.15	4.96	0.76	14 373	15 443	
10 Kentucky Cannel	{ Float	0.97	13.40	1.74	13 560	16 205	-26
	{ Sink	1.20	39.04	2.87	8 908	16 179	
11 Pennsylvania Anthracite	{ Float	0.86	7.20	0.72	13 795	15 166	+66
	{ Sink	0.70	16.75	1.07	12 280	15 232	

need be given. However, those selected are typical and cover widely separated localities and practically all types of coal.

Table III is an assembly of results from samples which have been subjected to the "sink-and-float" process. By this procedure each sample is divided into two parts with widely different values for the ash and sulfur. Manifestly the calculation of the indicated heat value to the corresponding value for the unit coal substance furnishes a crucial test for the suitability of the factors chosen for correcting the ash with reference to water of hydration and for sulfur.

At least two other methods have been used to a greater or less extent for deriving the pure coal substance. If the results obtained by use of these formulas are compared with those obtained by the one here proposed, the discrepancies resulting in the case of the sink-and-float samples of the same coal afford further confirmation of the value of the new formula. A tabulated selection of a few cases only can be given in this connection, as shown in Table IV.

The derivation of (a), (b) and (c) by the formulas as given in Table IV may be understood from the following:

The expression B.t.u. is the indicated heat value as obtained directly by means of the calorimeter. A is the ash as weighed, and S is the sulfur in per cent.

The method under (a) is the usual "ash and moisture-free" formula as employed by the engineer for determining the heat values for "combustible."

Under (b) is the method employed by Lord and Haas for determining the value of H , *i.e.*, the heat to be credited to the pure coal substance free from moisture, ash and sulfur.¹

Under (c) the formula is that for "unit coal" as herein presented and has already been discussed in detail.

Note that the analytical values are on the "dry-coal" or moisture-free basis. Hence W for water is not introduced into the formulas.

The marked agreement in float-and-sink values under (c) is additional evidence of the correctness of the formula as herein developed.

¹ *Trans. Am. Inst. Mining Eng.*, vol. 27. p. 259, 1897; also Lord and Somermeier, Report on coal: Ohio State 4th Geol. Survey. p. 268, 1908.

TABLE IV.—COMPARISON OF HEAT VALUES FOR PURE COAL SUBSTANCE AS DERIVED BY THREE METHODS OF CALCULATION

Description	Analytical values on dry-coal basis		Different methods of calculating for pure coal values			
	Ash	Sulfur	B.t.u. by oxygen bomb calorimeter	(a) B.t.u. 1.00 - A	(b) $\frac{\text{B.t.u.} - 4,050S}{1.00 - (A - S)}$	(c) $\frac{\text{B.t.u.} - 5,000S}{1.00 - (1.08A - \frac{4}{3}S)}$
1 Illinois Williamson Co.	4.08	0.99	13 924	14 535	14 644	14 623
	17.75	1.15	11 766	14 306	14 451	14 608
			Differences in calculated values	229	193	15
2 Illinois Franklin Co.	4.64	0.54	13 765	14 436	14 492	14 512
	18.00	0.57	11 639	14 194	14 236	14 474
			Differences in calculated values	242	256	38
3 Illinois Perry Co.	4.22	0.86	13 763	14 369	14 464	14 452
	22.17	1.15	10 922	14 033	14 183	14 413
			Differences in calculated values	336	281	39

Correction for Coals with High Carbonate Content.—When coals containing calcite along with the pyrites are ashed, an indefinite mixture of calcium sulfide and calcium sulfate is formed. In an extended study of the discrepancies between the ash values obtained for the same coal by one or more analysts, it was found that this reaction was the source of most of the trouble.¹ For Illinois coals, nearly 50 per cent of the samples have calcium carbonate present in excess of 1.0 per cent of the raw coal, 20 per cent have more than 2.0 per cent carbonate, and 3 per cent have over 4.0 per cent of this constituent. No argument is necessary therefore as to the advisability of taking note of this constituent and including it in the list of substances determined. The modifications necessary in the ashing procedure and calculations of unit coal value for coals containing carbon dioxide to an extent of over 0.5 per cent are as follows:

The ash after preliminary burning off of the carbon and cooling is moistened with a few drops of sulfuric acid (diluted 1:1) and again, after drying, brought up to 750°C. and retained at that temperature for 3 to 5 min. The capsule is cooled and weighed. The calcium, originally present in the coal as carbonate and partly changed to the oxide and sulfate during the first ignition, is now present entirely as the sulfate. The weight of this ash is now corrected by subtracting three times the weight of carbon present as carbonate in the unburned coal, in order to restore the weight of the sulfate to its equivalent of calcium carbonate.

The corrected formula for the non-coal substance to be used for high-carbonate coals therefore becomes:

$$\text{Non-coal} = M + A - 3C + \frac{5}{8}S + 0.08[A - (\frac{3}{3}C + \frac{10}{8}S)]$$

where C is the percentage of carbon occurring as carbonate in the unburned coal, and M , A and S have their former significance. This simplifies for the dry coal to

$$\text{Non-coal} = A + \frac{22}{40}S - \frac{293}{75}C.$$

Significance of Volatile Matter.—The other distinguishing factor, that is, the ratio of the volatile matter to the unit fuel, is

¹ PARR, S. W., Chemical study of Illinois coals: Ill. State Geol. Survey. *Bull.* 3, 1916.

an equally important factor in determining the type to which a fuel should be assigned. It will be evident at once that the factor for the volatile matter may also be derived by means of the same corrections that are used in developing the unit substance. Since the volatile matter as determined in the ordinary method of proximate analysis includes as a non-coal constituent the water of hydration of the shaly constituents of the ash, and essentially one-half of the total sulfur, these factors may enter into the calculations in deriving the unit volatile matter of the coal. Hence, the actual or true volatile matter V results from the following expressions:

$$V = \text{volatile as determined} - (\text{water of hydration} + \frac{1}{2}S)$$

$$(\text{water of hydration} = 0.08 [\text{ash as weighed} - \frac{10}{8}S])$$

$$V = \text{volatile as determined} - 0.08 (\text{ash as weighed} - \frac{10}{8}S) - \frac{1}{2}S.$$

$$V = \text{volatile as determined} - (0.08A + 0.4S)$$

Hence, percentage of V , or unit volatile

$$= \frac{\text{volatile as determined} - (0.08A + 0.4S)}{1.00 - (1.08A + 0.55S)}$$

These expressions are based on dry-coal values and their derivation is readily understood from the illustrations given for the development of the formula for unit coal. One item only may call for a word of explanation. The desirability of eliminating the sulfur from the volatile matter is obvious. This is accomplished by subtracting one-half of the total sulfur present in the coal. Warrant for the use of this factor is found in *University of Illinois Studies* No. 7.¹ Here are given the values, for total and "fixed" sulfur, and "volatile sulfur" by difference. For the 150 samples of coal analyzed especially for deriving these factors, the average percentage of sulfur discharged in the volatile form, in the ordinary method of determination of volatile matter and fixed carbon, was 51.5 per cent of the total sulfur present in the coal.

Use of Calorific Value and Percentage Volatile Matter as Basis of Classification.—In order to utilize the two factors thus obtained, namely, the calorific value of the unit fuel and the

¹ PARR, S. W., *The University Studies*, vol. 1, No. 7, p. 24, 1904; and Table, IX, pp. 33-40.

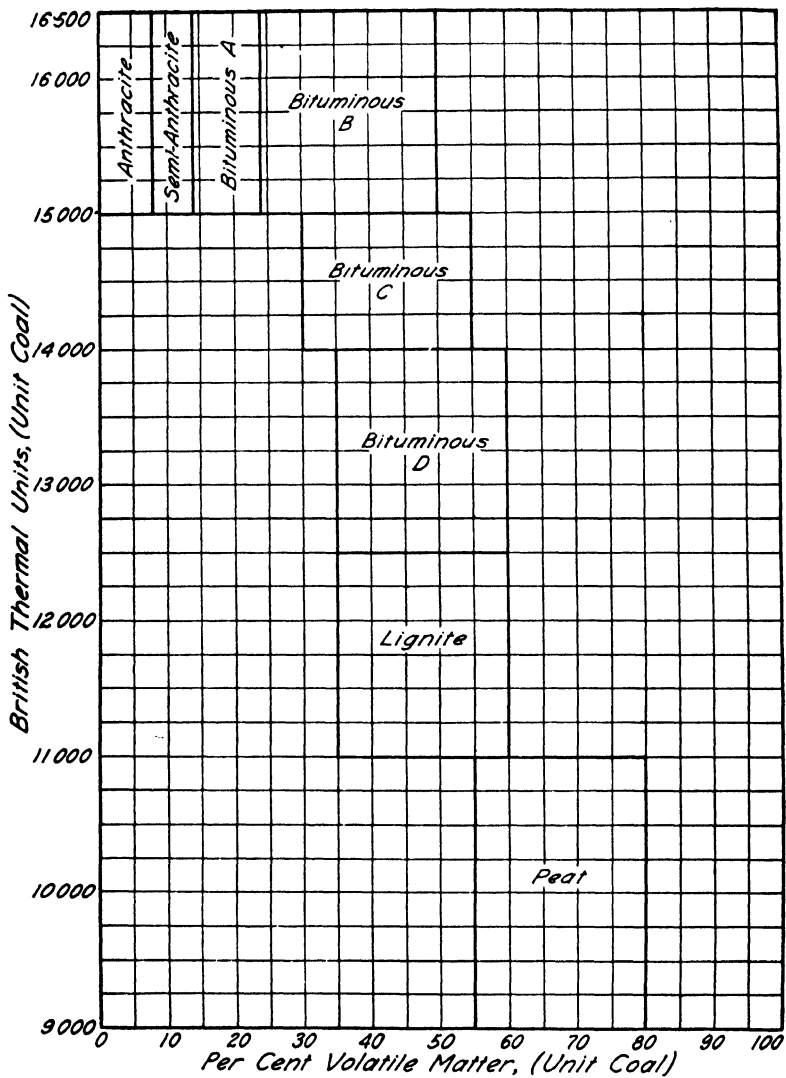

FIG. 20.—Demarcation of type areas as determined by heat values and volatile matter for unit components.

percentage of unit volatile matter, a two-dimension chart is employed in which the abscissas give the percentage of unit volatile matter and the ordinates the thermal values of the unit fuel substance, as shown in Fig. 20. The areas shown on the chart, moreover, will not only indicate the limiting boundaries for the several types of solid fuel, but any individual sample will automatically be so located within its group boundary as to show its relation to the group as a whole and to neighboring groups as well. In this manner, as should naturally be expected, there will be found a certain amount of blending of types at the group boundaries; but even so, this is in accord with the fact that the processes of formation have been progressive in character rather than definitive. An advantage, even, may be thus seen in the fact that the location of an individual type within its group area becomes significant. The chart as presented in Fig. 20 is intended, therefore, to indicate simply the areas for the types of natural solid fuels as here recognized.

For the purpose of locating a coal within the area which will represent its type, it will be seen that it is only necessary to make a calculation from the values obtained in an ordinary proximate analysis, including the calorific value and the sulfur content, as already shown.

Representative Analytical Data for Type Samples of Solid Fuels.—It will be in order now to assemble representative analytical data for the different solid fuels so that the type characteristics of each may be developed. It will be evident at once that of the mass of analytical values now available only a limited number can be used, but an attempt has been made to make representative selections in sufficient number to furnish a good illustration of the various types now generally recognized. The fuels may be divided according to the following types:

- Type 1. Anthracite.
- Type 2. Semi-anthracite.
- Type 3. Bituminous A (Low volatile or Pocahontas).
- Type 4. Bituminous B (Eastern).
- Type 5. Bituminous C (Mid-continental).
- Type 6. Bituminous D (Sub-bituminous or black lignite).
- Type 7. Lignite.
- Type 8. Peat.
- Type 9. Cannel.

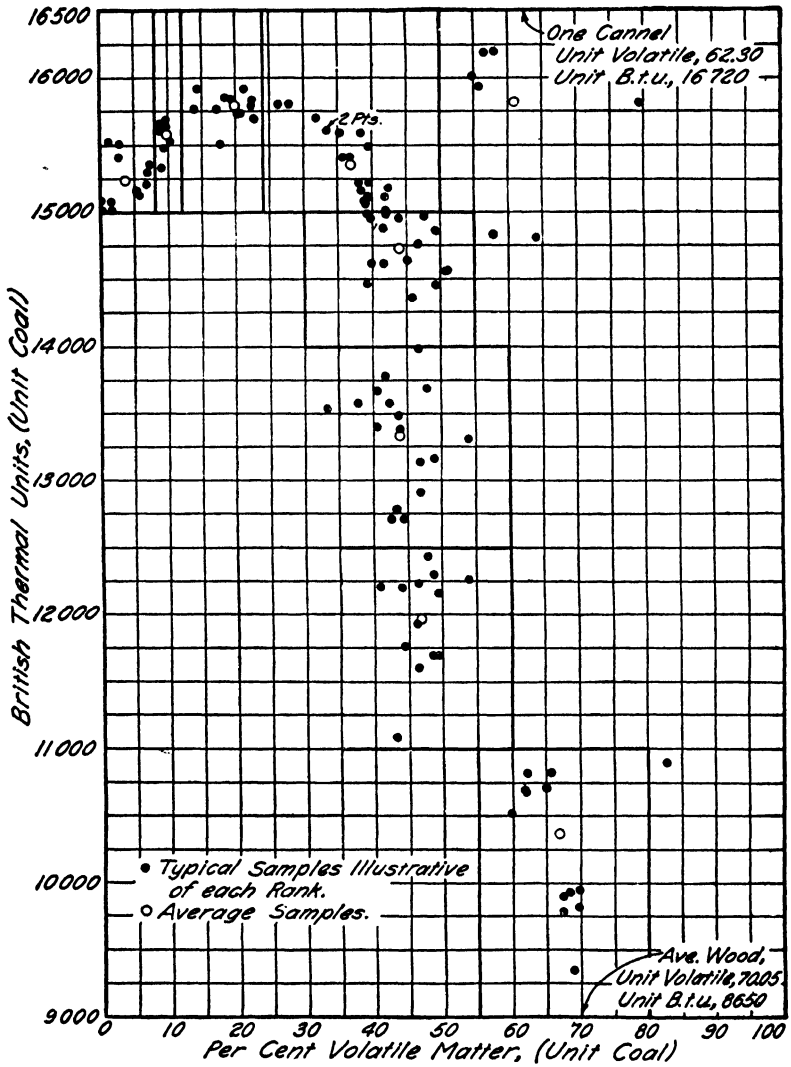

FIG. 21.—Location of type samples of American coals.

In Fig. 21 a few type coals for each group have been located by dots, while the average for each group has been located on the chart by small circles. A summary of the various types showing the limiting and average thermal and volatile values is given in Table V.

TABLE V.—THERMAL AND VOLATILE LIMITS IN THE CLASSIFICATION OF COAL

Coal	Unit volatile, per cent			Unit B.t.u.		
	Low	High	Average	Low	High	Average
1 Anthracite.....	0	8	3.53	15,000	16,500	15,239
2 Semi-anthracite.....	8	12	9.83	15,000	16,500	15,580
3 Bituminous A.....	12	24	19.87	15,000	16,500	15,795
4 Bituminous B.....	24	50	36.85	15,000	16,500	15,365
5 Bituminous C.....	30	55	43.82	14,000	15,000	14,727
6 Bituminous D.....	35	60	43.80	12,500	14,000	13,330
7 Lignite.....	35	60	46.86	11,000	12,500	11,970
8 Peat.....	55	80	66.80	9,000	11,000	10,370
9 Cannel.....	50	80	60.85	15,000	16,500	15,820
Sub-cannel.....	55	80		14,000	15,000	
Strays.....	Not in above classes					

It will be of further interest to compare the distribution of the various coal types according to this classification with that of the earlier classification used in the United States and also with Seyler's classification of English coals. Such a comparison is shown in Table VI.

Derivation of the Factor 5,000S.—In the first place it should be borne in mind that the purpose of the unit-coal formula is to arrive at the actual weight of unit coal, and to derive the actual heat per unit weight to be credited to this material. Therefore, for this particular purpose, sulfur must be eliminated.

The expression 5,000S has been used as indicating the heat of combustion of the sulfur rather than 4,050, for the reason that the latter value represents the heat of combustion of pure sulfur, while the former combines the heat of combustion of pyrites (Fe_2O_3) to give the figure desired.

TABLE VI.—COMPARATIVE CLASSIFICATION OF SOLID FUELS

Earlier classification as developed in the United States	Classification by Seyler	Present proposed classification
1. Anthracite	1. Anthracite	1. Anthracite
2. Semi-anthracite	2. Carbonaceous	2. Semi-anthracites
3. Semi-bituminous or low volatile	3. Meta-bituminous (Short flame)	3. Bituminous A
4. Bituminous (Eastern field)	4. Ortho-bituminous (True bituminous)	4. Bituminous B
5. Bituminous (Mid-continental field)	5. Para-bituminous (Low flame)	5. Bituminous C
6. Lignite, black, or sub-bituminous	6. Lignitous	6. Bituminous D
7. Lignite, brown	7. Lignitous	7. Lignite
		8. Peat
		9. Cannel
		10. Wood

According to Somermeier,¹ in the combustion of coal with known weights of iron pyrites, the indicated heat per gram of sulfur so combined is 4,957 cal. In calculating heat values the correction introduced for the combinations resulting from calorimeter reactions as compared with open-air combustion is 2,042 cal. per gram of pyritic sulfur. Hence 4,957 - 2,042, or 2,915, cal. (5,247 B.t.u.) represents the heat due to the burning of 1 gram of sulfur in pyritic form instead of 2,250 cal. (4,050 B.t.u.), the amount which would be credited to sulfur in the free condition. A strict application of these values, therefore, would call for a correction of 5,247S as representing the heat to be subtracted for the sulfur. This would imply that all of the sulfur is in pyritic form but, since a certain portion is always present in organic or other form of less heat-producing capacity, it is deemed more nearly correct to use an even factor of 5,000 as representing the heat to be credited to unit amounts of the total sulfur present.

¹ SOMERMEIER, E. E., Sulfur in coal: *Jour. Am. Chem. Soc.*, vol. 26, p. 566, 1904.

CHAPTER VII

OXYGEN ABSORPTION BY COAL

Introduction.—Studies relating to the behavior of coal toward oxygen have for their purpose the determination of the fundamental factors that underlie spontaneous combustion, weathering and deterioration, and the general topic of storage as well as those properties that have to do with coke structure and the process of carbonization. There is also involved the possibility of developing information relating to the constitution of coal or, at least, the chemical properties inherent in the type substances of which the coal is composed. The importance of the rôle played by oxygen in every phase of coal studies cannot be over-emphasized and is the sufficient reason for the elaboration of studies on oxygen here presented.

The avidity of freshly mined coal for oxygen has long been known. What happens to the coal or to the oxygen is not so clear. Is the oxygen absorbed or chemically combined, and what are the conditions as to time, temperature, texture or components that are most involved in the phenomenon?

If we subject a weighed quantity of coal maintained at a constant temperature to a current of oxygen we may obtain three factors of interest, namely: the weight increase of the coal, the weight of the water, and the weight of the carbon dioxide formed in the reactions involved at that temperature.

Experimental Methods.—The apparatus¹ used is a modification of one devised by Professor John A. White, of Rose Polytechnic Institute² (see Fig. 22). The main feature is a double-wall tube so arranged that the inner space may be maintained at a constant temperature by means of the vapor from a boiling liquid in a flask below. A reflux condenser is attached, from

¹ PARR, S. W., and MILNER, R. T., The oxidation of coal at storage temperatures: *Ind. Eng. Chem.*, vol. 17, p. 115, 1925.

² WHITE, J. A., *Jour. Franklin Inst.*, vol. 173, p. 201, 1911.

which the condensed vapors are returned through a by-pass to the flask. Mercury-sealed cups are used for connections so the apparatus can be easily dismantled. Coal to the extent of 20 grams is put into an aluminum boat and placed in the inner tube. Telescoping tubes for housing the aluminum boat and sample are employed during the time of the removal of the boat for weighing. With the outfit thus assembled any gas can be made to circulate over the sample, and absorption trains are attached for purification or collection of by-products. Moreover, the apparatus

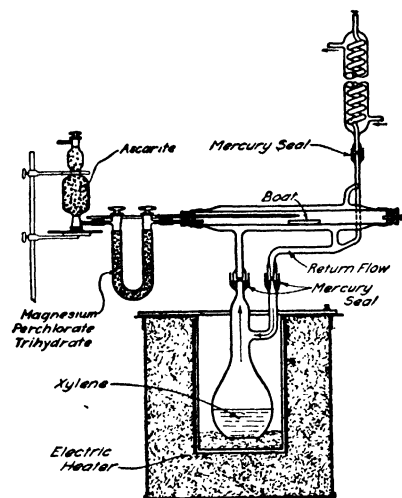

Fig. 22.—Apparatus used for studies in absorption of oxygen by coal.

readily lends itself to the maintenance of a constant temperature over long periods of time; for example, from 1 to 5 months. Acetone vapors were used to provide a temperature of 55°C., carbon tetrachloride at 75°C., water at 100°C., toluene 110°C. and xylene 140°C. In order to parallel operations several of these instruments were available.

For the preliminary preparation of the sample an atmosphere of nitrogen, purified by washing through pyrogallate, caustic potash and concentrated sulfuric acid was used. After passage of the nitrogen at the determined temperature until equilibrium was established, or as nearly so as possible, oxygen was passed through the same train, omitting of course the pyrogallate solution.

The preliminary passage of nitrogen was continued until about 5 days after the coal had ceased to lose weight. The tubes and boat were weighed daily. In weighing, the boat was placed in the large telescoping capsule immediately after removal from the apparatus, allowed to cool in a desiccator and weighed in the capsule. These precautions were taken to avoid the absorption of moisture from the air by the dry, finely divided coal.¹

¹ For details of manipulation see Parr and Milner, *loc. cit.*

Results of Oxygen-absorption Studies.—The accompanying charts show the results of typical tests at various temperatures.

Figure 23 shows the amount of moisture and carbon dioxide discharged at 100°C. over a period of 44 days. Notwithstanding

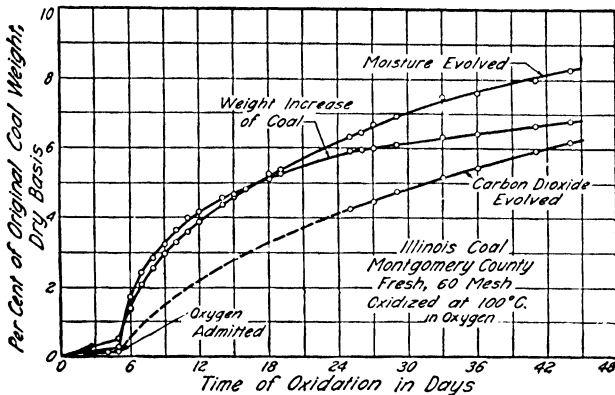

FIG. 23.—Effect of oxygen on coal at 100°C.

the notable amount of these constituents discharged, there was a steady increase in weight throughout the period. These constituents represent a loss in weight, when calculated to carbon and hydrogen, of approximately 3 per cent of the original coal.

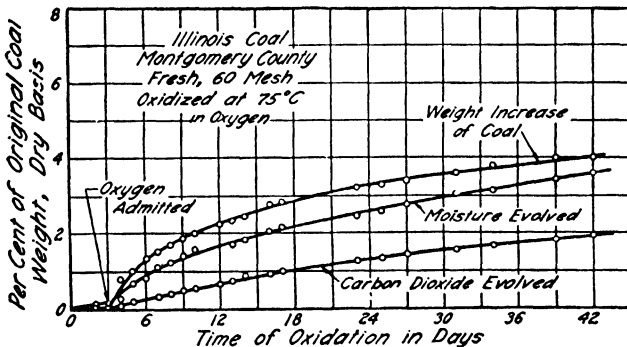

FIG. 24.—Effect of oxygen on coal at 75°C.

The increase in weight due to oxygen absorbed is greater than this loss and is presumably at first taken on in an absorbed state from which it gradually proceeds to a chemical combination resulting in the weights of moisture and carbon dioxide as shown.

The charts of Figs. 24, 25 and 26, with temperatures maintained, respectively, at 75, 55 and 25°C., show similar results, differing only in amount.

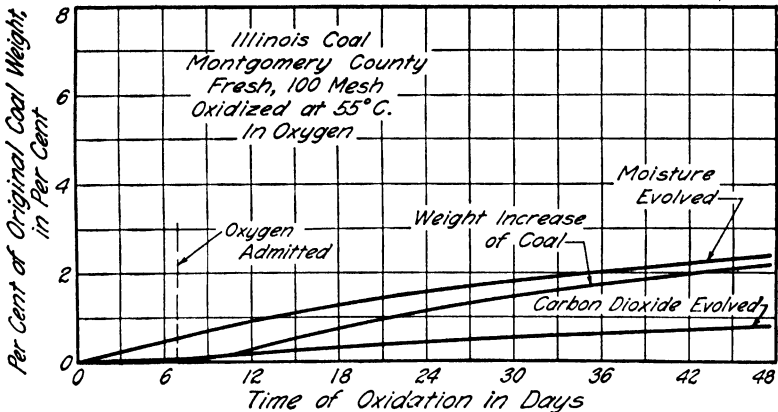

FIG. 25.—Effect of oxygen on coal at 55°C.

Figure 27, giving the weight of carbon dioxide evolved at the four temperatures studied, shows the behavior of the coal for these temperatures. Obviously the values could be interpolated for all intervening temperatures.

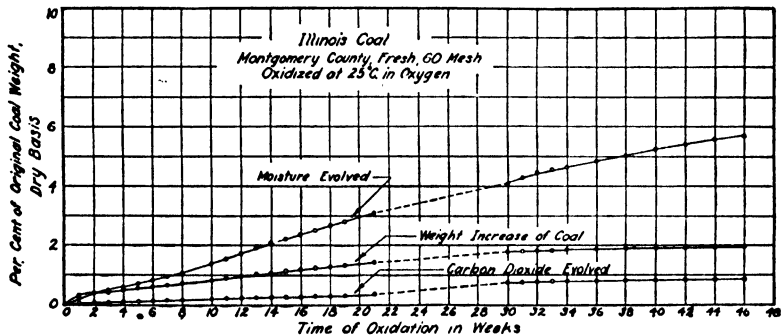

FIG. 26.—Effect of oxygen on coal at 25°C.

It is of further interest to note the effect of the oxygen absorption on the thermal values of the coals as shown in Fig. 28. The relation between the oxygen content and the heat content suggested in Chapter VI is borne out by the decreasing unit

B.t.u. values as oxidation proceeds, especially at the higher temperatures.

Charts showing the behavior of air instead of oxygen on the same coal at the same temperatures have been plotted. They

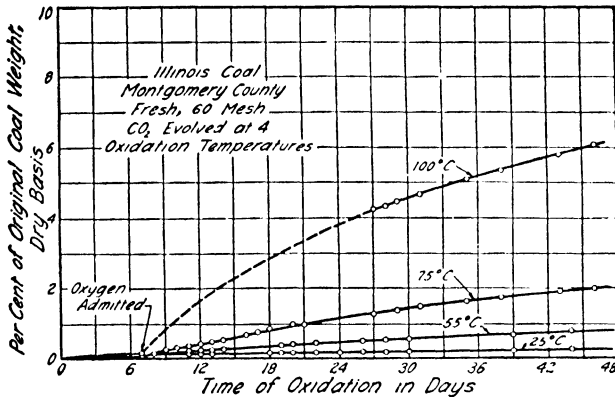

FIG. 27.—Carbon dioxide evolution from coal in atmosphere of pure oxygen at various temperatures.

show similar results excepting that the time is increased to approximately twice that for corresponding values with oxygen. The one for 110°C. is shown in Fig. 29.

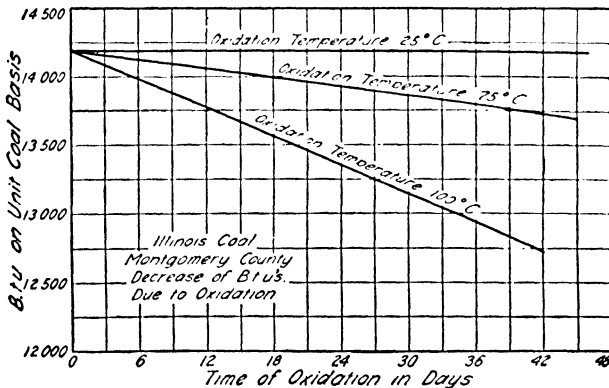

FIG. 28.—Effect of oxygen absorption on thermal value of unit coal.

In general, the coals studied show an increase in weight throughout the period, seemingly approaching a saturation point at about 8 per cent of the original weight.

Moisture equivalent to from 4 to 8 per cent of the weight of the sample is evolved, varying in amount with the temperature. The carbon dioxide evolved is equivalent to from 2 to 6 per cent of the sample. Carbon monoxide, where determined, is present but in very small percentages, not exceeding 1 per cent at 110°C.

The preliminary stage of heating in nitrogen shows a small generation of both water and carbon dioxide with a slight gain in weight by the coal, probably due to a small absorption of nitrogen. The water and carbon dioxide would naturally result from the breaking down of the oxygen compounds of the coal.

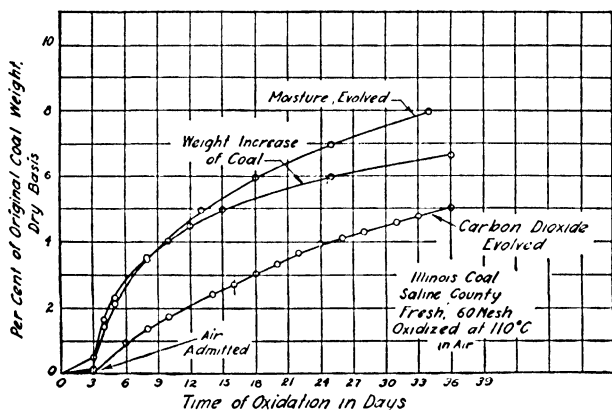

FIG. 29.—Effect of air on coal at 110°C.

By noting the discharge of one constituent, such as carbon dioxide for the different temperatures employed, it is evident that the amount increases directly with the increase of temperature. Attention is specifically called to the fact that at ordinary atmospheric temperatures this value is very low but consistent. The values for the other temperatures increase in an accelerated ratio with the increase in temperature.

From a composite study of the various charts it would appear that at normal temperatures, *i.e.*, below 50°C., the oxygen is taken on as a physical rather than a chemical accession, at first with extreme slowness, then more rapidly. As the temperature rises there are given off in determinable quantities both water and carbon dioxide. These products begin to appear at about 65 to 85°C., depending on the length of time the coal has been sub-

jected to oxygen saturation. After 100°C. has been passed, there is a constantly accelerated rise until about 140 or 150°C., when the temperature very rapidly proceeds to the ignition point. These results are illustrated graphically in Fig. 30.¹

Relation of Oxygen Absorption to Storage of Coal.—With reference to the initial, or first, stage of oxygen absorption at normal temperatures, coals differ in the ease with which they pass over from the merely physical to a chemical combination. It has already been pointed out that high-moisture coals have a higher capacity for the absorption of oxygen, and therefore are

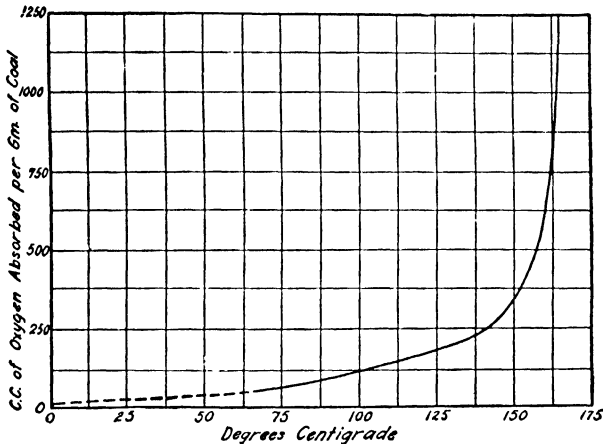

FIG. 30.—Effect of temperature on oxidation of coal.

able to acquire a larger supply of potential danger. The more dense and harder coals show less abrasion and accumulation of fines in the process of handling and shipment. Note should be made here of the fact that, as a general rule, density and hardness accompany low free moisture, while lightness and friability are accompanied by the higher percentages of moisture. It is also true, as above noted, that coals differ in the character of their compounds with reference to the ease or readiness with which they combine with oxygen. Here is a critical phase of these initial reactions to which we must look, in the absence of extrane-

¹ The curves and data contributing to this composite graph have been, for the most part, developed by R. T. Milner, C. C. Coons and T. Y. Cheng.

ous sources, for the starting point in the building up of the heat increments. But concerning these compounds and how to identify or label them we do not know. Actual or authenticated illustrations of types would seem to suggest the propriety of assigning storage qualities on the basis of size rather than type. For example, the high-moisture coals of the lignitic type would be set down as the most difficult to store without heating. The next in order of betterment would be the bituminous coals having from 12 to 15 per cent of moisture. The paramount factor in all bituminous coals, however, is fineness of division. This would include, of course, tendency to breakage and the production of fines in the process of handling and shipping. Those coals which disintegrate least on weathering are less ready to start active chemical reactions in the pile. This feature of oxygen absorption with reference to its bearing on the storage of coal is discussed later under the heading of Storage of Coal in Chapter IX.

CHAPTER VIII

THE IGNITION TEMPERATURE OF COAL

Initial Appearance of Carbon Dioxide.—From the preceding studies it is evident that coal is continuously reactive with oxygen to a greater or less degree, depending upon various factors but chiefly upon temperature. The two products most in evidence are, first, water and, then, carbon dioxide. An apparatus that would give the initial appearance of these products of oxidation would be of both practical and scientific interest. The difficulties attending the indication for the appearance of water are far greater than those for carbon dioxide; hence it is the latter that will be considered at this time.

The apparatus devised for this purpose uses a solution of barium hydroxide as the indicating medium. The temperature of the coal is controlled by an electric resistance coil so placed that a constant increase in temperature of about 10°C . per minute can be maintained.¹ The mechanism for indicating the appearance of carbon dioxide is shown in Fig. 31, while Fig. 32 is a photograph of the entire apparatus. The device for detecting the

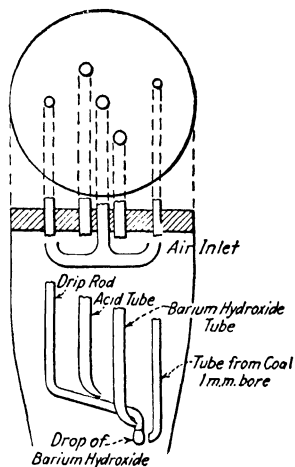

FIG. 31.—Carbon dioxide detection tube.

carbon dioxide is shown immediately below the furnace. The other accessories are for washing the gases used in the tests.

Purified oxygen is led into the upper part of the furnace and, after passing through the coal, is delivered below into the

¹ PARR, S. W., and COONS, C. C., Carbon dioxide as an index of the critical oxidation temperature for coal in storage: *Ind. Eng. Chem.*, vol. 17, p. 118, 1925.

detecting tube, through a 1-mm. capillary. This capillary is so placed that the gas from the coal impinges upon a drop of barium hydroxide suspended from a solid rod having a flat-ground tip. The barium hydroxide solution is contained in a separatory funnel having a soda-lime tube fitted into the top in order to remove the carbon dioxide and moisture from the air as the solution is removed from the funnel. The barium hydroxide solution is conducted to the lower end of the drip rod by a glass tube drawn out to a narrow tip which is placed so that it just touches the drip

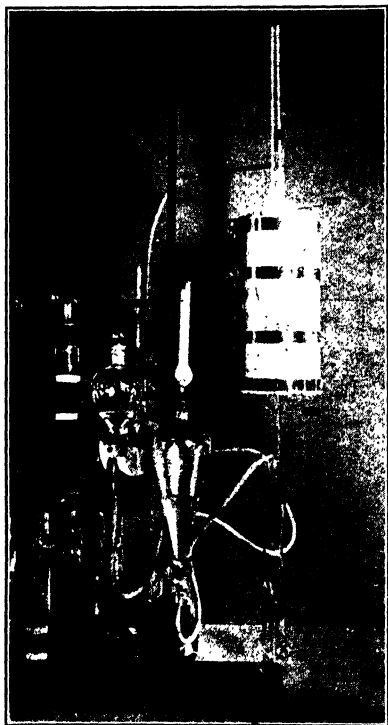

FIG. 32.—Apparatus for determining initial appearance of carbon dioxide in coal.

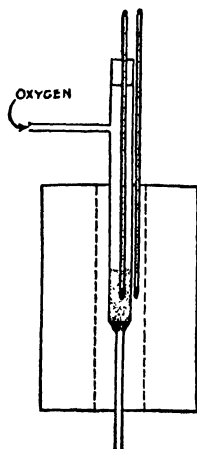

FIG. 33.—Apparatus for determining the critical oxidation temperature of coal.

rod. In this way a fine adjustment of the barium hydroxide can be obtained. An acid tube is placed directly above it so that, when necessary, any barium carbonate precipitate adhering to the drip rod can be conveniently removed. The arrangement of the coal sample and thermometers within the furnace are shown in Fig. 33. The results obtained in this study are shown in the curves of Figs. 34, 35 and 36 for several

representative coals. They will be discussed later, after the ignition point is considered.

Critical Oxidation Temperature.—The temperature at which the heat oxidation within the coal sample attains an impetus

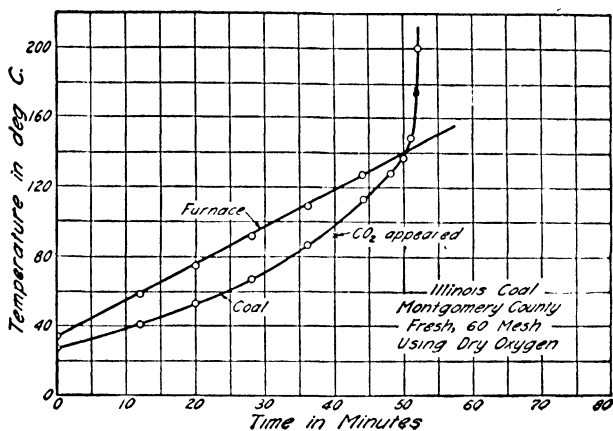

FIG. 34.

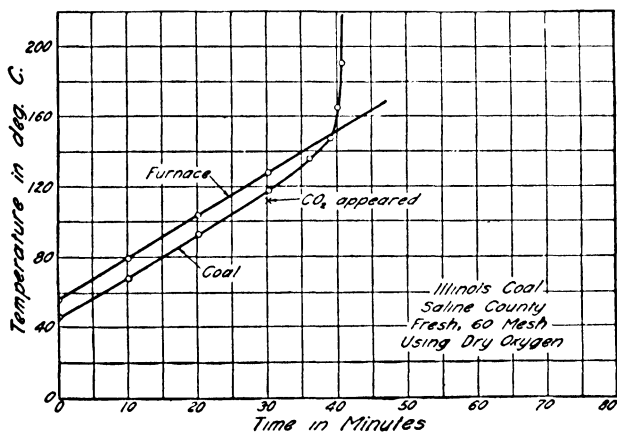

FIG. 35.

FIGS. 34 and 35.—Carbon dioxide appearance and critical oxidation temperatures for various fresh coals.

whereby it becomes self-propelling, or autogenous, is obtained by plotting the readings of the two thermometers against time and noting the point of intersection of the two lines. This point is

of such great significance from the standpoint of spontaneous combustion of coal that it is here designated as the critical oxidation temperature. Determinations of this point were made upon a number of freshly prepared samples and also upon parallel samples of the same coals which had been subjected to oxidation by what might be called complete "weathering," or saturation with oxygen at a temperature below the critical point.

A few typical charts giving the results on freshly prepared samples are first presented as Figs. 34, 35 and 36. The critical oxidation temperatures for the samples of Illinois coal are within

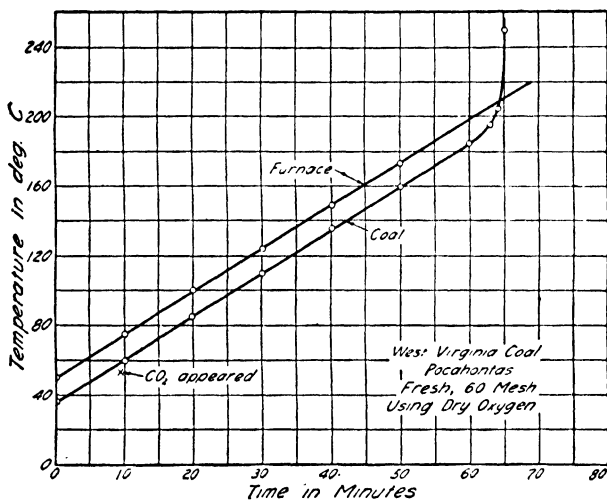

FIG. 36.—Carbon dioxide appearance and critical oxidation temperatures for various fresh coals.

a range of 138 to 143°C., and the corresponding temperature for the Pocahontas coal is 202°C. A compilation of the ignition temperatures of various coals as determined by this method is shown in Table VII.

The initial appearance of carbon dioxide occurs of course in all cases below the critical oxidation temperature. In the case of the Pocahontas coal, however, the gas appears at such a low temperature, compared to that of critical oxidation, that it is evident that slow oxidation must take place in the higher type of coals at temperatures far below the point at which the reaction becomes autogenous.

It seems fair to conclude that, in case of coals in storage, assuming free accessibility of oxygen, a temperature within the

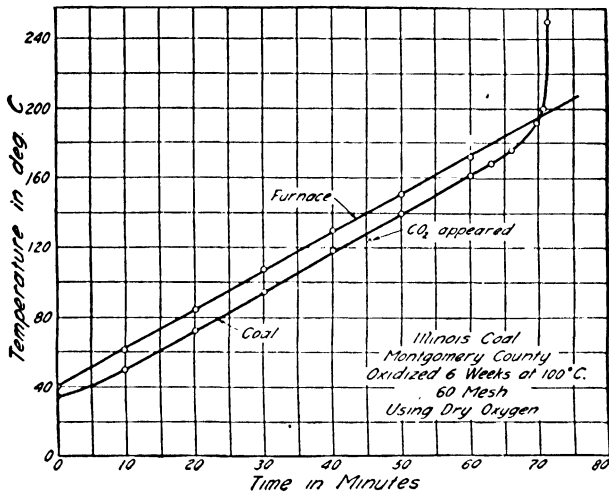

FIG. 37.—Carbon dioxide appearance and critical oxidation temperature for a weathered coal—to be compared with Fig. 33.

mass approximating the range indicated by the charts would denote a speedy progression to the stage of actual ignition.

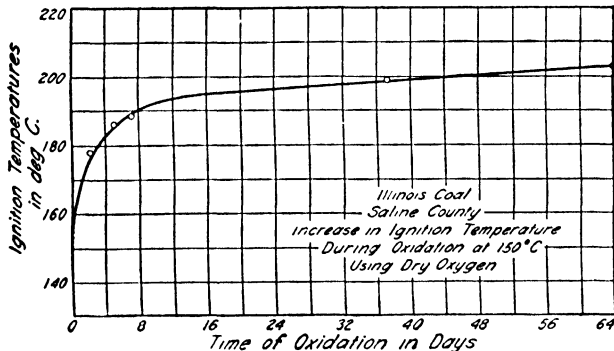

FIG. 38.—Increase in ignition temperature caused by "weathering" at 150°C. in pure oxygen.

Although these charts are based on the use of pure oxygen, the conditions under contact with the oxygen of the air would show a lag as to time but substantially in agreement as to effect,

TABLE VII.—IGNITION TEMPERATURES OF VARIOUS ILLINOIS COALS

Location	Ignition temperature in degrees Centigrade
Perry Co., Majestic Mine, DuQuoin.....	158
Perry Co., Dowell Mine, DuQuoin.....	159
Perry Co., Willisville Mine No. 6.....	157
Perry Co., Clinch.....	157
Perry Co., Gayle Coal Co., Strip Pit.....	153
Perry Co., Scott Smith Co., Strip Pit.....	152
Jackson Co., Consol. Coal Co. No. 9.....	159
Jackson Co., Gus Blair Mine No. 3.....	159
Jackson Co., Carbondale.....	169
Jackson Co., Murphysboro No. 1.....	167
Jackson Co., Murphysboro No. 2.....	153
Jackson Co., Murphysboro No. 3.....	157
Vermilion Co., Westville.....	153
Vermilion Co., Danville Strip Mine.....	153
Randolph Co., Percy.....	159
Williamson Co., Herrin.....	159
Franklin Co.....	153
Marion Co., Odin.....	159
Saline Co., Harrisburg.....	157
Montgomery Co., Nokomis.....	153
Sangamon Co., Riverton.....	153
Grundy Co., Leland Mine No. 7, Verona.....	152
Madison Co., Livingston.....	147

provided other things, such as radiation, are the same. Figure 37 repeats the conditions on the Montgomery County coal, but after it had been saturated with oxygen, that is, "weathered" at an oven temperature of 100°C. A consistent increase in the critical range of oxidation is evident. Figure 38 represents the temperature required to produce autogenous oxidation for the several stages of weathering with coal from Saline County.

CHAPTER IX

THE STORAGE OF COAL

From the preceding discussion, relating to the absorption of oxygen and the relatively low ignition point of bituminous coals, we have developed the fundamental factors which underlie the tendency of coals to become heated when piled in large masses. These factors thus far discussed are of a chemical nature and as such are closely related to the rank or type of the various bituminous coals, those of Class D or C being more susceptible to oxidation than those of Class B or A. But, obviously, physical conditions enter into the case. A finely divided coal, for example, is more actively affected by oxygen than one retained in the lump form. Thus finely divided coal of Class A may be more active in the absorption of oxygen than lump coal in Class C.

One of the pioneer studies, as well as the most extended on the physical conditions governing the spontaneous combustion, is described in *Bulletin* 46 of the University of Illinois Engineering Experiment Station and a summary of the conclusions arrived at are included in this discussion.¹

Extended studies on the causes of spontaneous combustion have been carried on in England, especially in connection with fires on shipboard.²

Since the causes of spontaneous combustion are directly fundamental to the matter of the storage of coal, further discussion will naturally relate itself to this latter topic under which we shall first investigate the conditions which facilitate the accessibility and the activity of the oxygen.

Slacking of Coals.—In some types of coal, especially those of high moisture content as well as lignites, the transpiration of

¹ PARR, S. W., and KRESSMAN, F. W., The spontaneous combustion of coal: Univ. Ill. Eng. Expt. Sta., *Bull.* 46, 1910.

² Fires in steamship bunkers and cargo coal: Dept. Sci. and Ind. Fuel Research. London, *Spec. Rept.* 5.

their moisture content, outwardly, upon drying leaves a network of textural porosity which would weaken the normal bonding property of the coal. If this is followed by wetting or submergence in water the forces set up by capillary action quickly drive out the absorbed air and disseminate water through the entire texture of the coal still further weakening its texture, with the result that the coal disintegrates or "slacks." Other coals of higher rank are sometimes said to slack after a more or less extended period of storage. This type of disintegration, however, is not due to the transpiration of water outward but to the absorption of water, especially along such porous bedding planes as would be supplied by the fusain. The capillary forces thus set up tend to disrupt the bond in that material which at best is very weak, with the result that such coals break down to a greater extent on storage than others of the same type and age but with less distribution of porous layers. This method of disintegration along bedding planes is not slacking in the sense that such a term is applied for example to lignites. Its extent is substantially governed by the frequency or structure of the porous bedding planes and should not be taken as a criterion of rank for designation of the type or class to which the coal belongs. Under the conditions which prevail in a lignite we would expect not only a rapid but a complete and uniformly distributed breaking down of the coal structure. Under the bedding-plane method of rupture there would be an irregular procedure, with the limit of action governed by the character or frequency of the porous layers.

This latter condition is illustrated in a study of the actual storage or car lots, kept for 6 years under varying conditions of weathering, handling and, finally, followed by combustion in standard boiler-efficiency tests.¹ The storage bins used in the tests are shown in Figs. 39 and 40. One half of each carload of coal was piled in the open air to a uniform depth of $3\frac{1}{2}$ ft. in shallow bins with earth floors. The other half carload was put in covered wooden bins, partly open on two sides, with board floors $1\frac{1}{2}$ ft. above the ground. The coal filled these bins to a depth of about 5 ft. The samples used in this series of tests

¹ PARR, S. W., Effects of storage upon the properties of coal: Univ. Ill. Eng. Expt. Sta., Bull. 97, 1917.

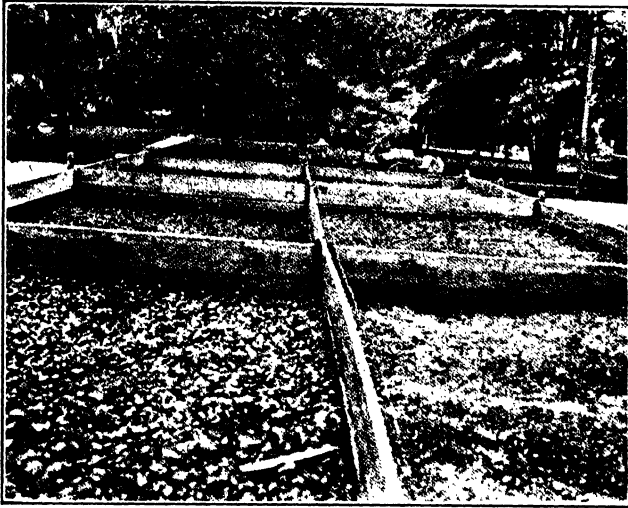

FIG. 39.

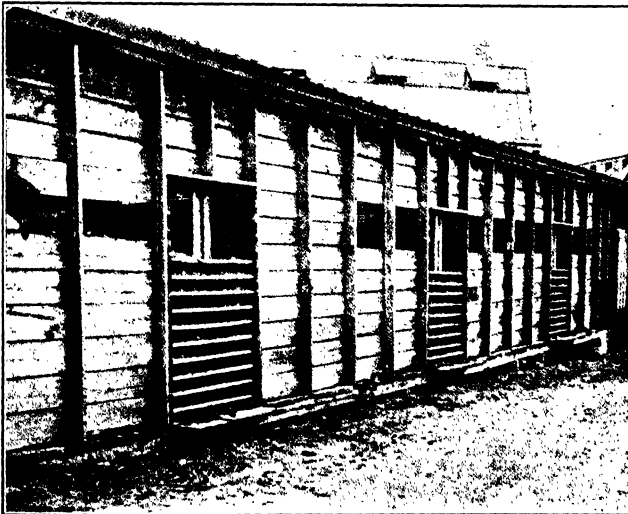

FIG. 40.

FIGS. 39 and 40.—Coal bins used in 6-year storage tests.

came entirely from mines located in Vermilion, Sangamon and Williamson counties, Illinois.

The extent of disintegration or slacking which takes place in connection with the storage of coal is a matter of considerable importance because of the effect upon combustion on the grates where a large amount of finely divided material is present. Three sizing tests were made on the stored samples: one at the time the coal was placed in storage, one after a period of 18 months and one at the end of 6 years. A summary of the results is shown in Table VIII. The rate of disintegration is consistent with the variety of coal.

TABLE VIII.—INCREASE IN FINE MATERIAL AFTER 1½ AND 6 YEARS
(Basis of reference: the total coarse material in the original coal passing over ¼-in. screen)

Table No.	Coal and county	How stored	Initial storage		After 1½ years		After 6 years	
			Dust passing ¼-inch screen	Dust Passing ¼-inch screen	Percentage increase of fine material referred to original coal over ¼-inch	Dust passing ¼-inch screen	Percentage increase of fine material referred to original coal over ¼-inch	
1	Nut— Sangamon.....	Open	1.2	13.2	12.1	31.9	31.0	
2	Nut— Vermilion.....	Open	13.6	24.0	12.0	35.0	24.7	
3	Nut— Williamson.....	Covered	1.4	11.0	11.1	13.9	12.6	
4	Screenings— Sangamon.....	Covered	26.3	38.5	16.5	45.1	25.5	
5	Screenings— Vermilion.....	Open	37.7	48.4	17.1	49.6	19.1	
6	Screenings— Williamson.....	Covered	38.8	45.4	10.7	50.6	19.2	

Effect of Storage on Unit Coal and Ash Content.—Oxidation of the organic materials in coals is active in all coals of the bituminous and lignitic types. The conditions which accelerate the action are: increase of temperature and fineness of division. The heating value decreases most rapidly during the first week after mining and continues to decrease more and more slowly for an indefinite time. One per cent is about the average loss for the

first week, and an additional loss of 2 or 3 per cent may occur by the end of the first year. These losses are due not only to the absorption of oxygen but also to the escape of combustible gases and to an increase in weight of the combustible portion of the coal. The results of the effect of the 6-year storage tests on the unit coal values and ash content of the three coals used are shown in Table IX.

TABLE IX.—RESULTS OF STORAGE OF COAL FOR 6 YEARS

Coal	Size	Percentage of ash, dry basis			Unit coal, B.t.u.			
		Fresh	After 6 years	Differ- ence	Fresh	After 6 years	Differ- ence	Differ- ence by per cent
Vermilion County	Nut	13.76	11.45	2.31	14,632	13,934	698	4.8
	Screenings	15.18	14.11	1.07	14,791	13,302	1489	10.1
Sangamon County	Nut	16.86	12.96	3.90	14,613	13,790	823	5.6
	Screenings	17.13	14.95	2.18	14,524	13,604	920	6.3
Williamson County	Nut	14.41	13.41	1.00	14,838	14,265	573	3.9
	Screenings	14.72	13.03	1.69	14,716	14,170	546	3.7

Note that these values indicate only general conditions. Part of the loss in ash should be accredited to oxidation of sulfur and leaching out of the soluble material.

The relative ash values show a consistent lowering of the percentages of ash during storage. This result obviously is normal since actual increase in the weight of the organic constituents of coal must result in a relatively lower amount of ash or an apparent decrease in ash. There is also a small amount of inorganic material lost, owing to the oxidation of the sulfur and leaching out of the soluble sulfates.

Boiler Tests on Weathered Coal.—Upon completion of the storage experiments at the end of the 6-year period, boiler tests were conducted under standard conditions and the results were compared with those obtained in similar tests made with the same boiler using fresh coal.¹ The fresh coal used for a standard of comparison was from Vermilion County, Ill., upon which 19

¹ KRATZ, A. P., A study of boiler losses: Univ. Ill. Eng. Expt. Sta., *Bull.* 78, 1915.

tests were made. The ash content and percentage of finely divided material did not differ greatly in the standard from those present in the weathered samples. A comparison of the over-all efficiencies obtained in these tests is shown in Table X. A

TABLE X.—RESULTS OF BOILER TESTS WITH MISSION FIELD FRESH COAL AND WITH WEATHERED COAL AFTER 6 YEARS IN STORAGE

Mission Field fresh coal			Weathered coal			
Test No.	Boiler h.p. developed	Efficiency of boiler, furnace and grate, per cent	Test No.	Coal and county	Boiler h.p. developed	Efficiency of boiler, furnace and grate, per cent
10	554 0	63 96	20	Nut—Sangamon Co.	568 5	64.50
11	569 6	61.21	21	Screenings—Sangamon Co.	557 2	63.05
12	572.7	60 67	22	Nut—Williamson Co.	727.1	65.98
13	589 0	69 87	23	Screenings— Williamson Co.	509 6	60.04
14	555.9	64 75	24	Nut—Vermilion Co.	655.0	64.20
15	506.6	65.50				
16	644 0	60.84				

general summary covering the behavior of the coal in steam generation after 6 years of storage is as follows:

1. Burning weathered coal is largely a question of correct handling and ignition. Under these circumstances it gives as good results as fresh screenings.
2. Weathered coal requires a little thinner fire and more draft than fresh screenings.
3. When using weathered coal the fuel bed should not approach any nearer to the water-back than 4 to 6 in., otherwise trouble with clinker is experienced.
4. The efficiency factors developed in the tests may be accepted as fairly representing results obtainable on weathered coal in which the heat loss resulting from weathering is practically negligible.

It is evident, therefore, that the deterioration of coal in storage largely results in a physical change and that the actual heat loss is small. Comparison of these results should be made with the

chart, Fig. 28, showing the heat losses for coal oxidized at temperatures of 100, 75 and 25°C. The B.t.u. losses at 25°C. are entirely consistent with the data obtained in the boiler tests.

The Effect of Sulfur on Spontaneous Combustion.—There is much lack of conclusive evidence as to the part sulfur plays in the spontaneous combustion of coal. In some coals the sulfur, because of either structure or size of particles, is more readily oxidized than in other cases. While we are at present more inclined to charge these initial heat reactions to carbonaceous material than to sulfur, it is by no means wise to ignore the presence of pyritic sulfur as a possible source of heat. It may also be noted that the dull bands and the “mineral charcoal” are the portions that contribute most largely to the ash, and quite uniformly also to the sulfur content of the commercial material as received. In this finely divided material, therefore, are possible factors which may accentuate the danger due to the forms in which sulfur occurs. Moreover, these conditions as to sulfur increase

are not constant, especially in the layers of mineral charcoal. Indeed, this material may vary as to its relative amount in the output of the same mine and differences in behavior may frequently be ascribed to sulfur forms and sizes rather than to the coal proper.

It is often suggested in the literature that the marcasitic form of iron sulfide is much more readily oxidized than the pyritic, yet there is little experimental evidence as to what extent this may be true.

In a preliminary investigation typical samples of these two crystals were selected and each ground to pass a 325-mesh sieve. The results, which are plotted in Fig. 41, show that at 25°C.

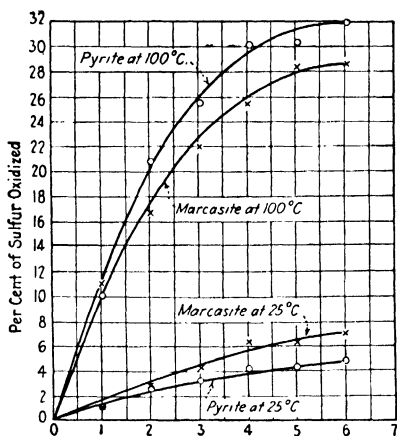

FIG. 41.—Comparison of rate of oxidation of pyrite and marcasite at 100° and 25°C. in oxygen saturated with moisture. Both minerals passed through 325-mesh sieve.

the marcasite has a slightly higher rate of oxidation, while at 100°C. the reverse is true. This may be owing to the fact that the increase of temperature has a slightly greater effect on the oxidation of pyrite than of marcasite. For a sample ground to pass through a 140- and caught on a 200-mesh sieve, the two oxidation curves are in general agreement with those for the smaller particles when they were oxidized at 100°C., the pyrite having a slightly higher rate of oxidation, while at 25°C. the relation is reversed.¹

This slightly higher rate of oxidation of marcasite at 25°C. does not necessarily indicate that it is more readily oxidized than pyrite. It is believed to be owing more largely to its highly fragile nature and to the resulting greater percentage of fine material produced during grinding. In samples of pyrite and marcasite ground to pass through a 200-mesh sieve it was found that the latter contains a higher proportion of the finer particles—92 per cent of the marcasite passing through a 325 mesh sieve, compared with 71 per cent of the pyrite. This ratio also probably holds for that portion which passes through the 325-mesh sieve.

Heating of Coal in Storage.—Reference has already been made to the behavior of oxygen in that it is absorbed, presumably, first in the physical stage, from which it passes over, slowly at atmospheric temperatures and rapidly at elevated temperatures, into chemical combinations with unsaturated compounds or in the ultimate forms of water and carbon dioxide. The heating of coal in storage may therefore be summarized as follows:

1. A high percentage of free or textural moisture in a coal indicates a high capacity for oxygen absorption. Such coals, immediately upon breaking out from the seam, begin to lose moisture until an equilibrium with the moisture of the atmosphere is established, thus making way for the accession of oxygen.

2. The larger the lumps of coal the slower the interchange is between the free or inherent moisture and oxygen. Conversely, the more finely divided the material the more rapid the interchange, and also the greater the superficial area of the coal particles.

¹ Li, S. H., The oxidation of pyrites as a factor in the spontaneous combustion of coal: *Ind. Eng. Chem.*, vol. 18, p. 1299, 1926.

3. Any departure from normal temperature upward, unless checked or dissipated, is a vital factor, whether such increase of temperature arises from external sources or is the result of chemical combinations within the coal itself.

4. Accessibility of air within the coal mass, thereby augmenting the supply of oxygen beyond the amount taken up by absorption, is essential for carrying the oxidation forward, thus bringing the temperature of the mass up to the point of ignition.

5. Accessibility of air, involving ready circulation to an extent which will carry away the initial increments of heat as rapidly as formed, will prevent a rise of temperature.

6. Complete prevention of an additional oxygen supply beyond that absorbed by the coal before entering the storage pile will insure against any appreciable or dangerous rise of temperature.

7. The oxidation of pyritic sulfur requires the presence of free moisture as well as oxygen. The augmenting of the heat in any manner greatly accelerates the oxidation processes for both the hydrocarbon and the sulfur components of the coal.

Conclusions.—It will be evident from what has preceded that spontaneous combustion of coal is simply a matter of extending the conditions for the absorption of oxygen. Therefore it will be necessary only to summarize the factors which must be considered in the storage of coal, in order to avoid the approach to those dangerous temperatures which lead inevitably to ignition of the mass.

1. Anthracite has a minimum capacity for oxygen absorption and can be stored substantially in any quantity without deterioration or danger of loss from spontaneous combustion.

2. In storing bituminous coal it is of fundamental importance that the coal be free from dust or duff—that is to say, material in any considerable quantity that would pass a $\frac{1}{4}$ -in. screen. In the case of lump coal, an addition of fine material in masses too large to admit of carrying away the initial increments of heat by transpiration of air currents will invite local heating in the areas where the fine coal is located. Conversely, slack or screenings with occasional zones of nut or lump sizes, where air may enter, will heat first at the margins of the areas where the coarse coal occurs.

Illustrations of these conditions will readily suggest themselves. A storage mass of lump coal adjacent to a pile of slack will heat at the border line. The piling of screenings in a way to create channels for the free passage of air, as by coning, with the consequent rolling down the side of nut sizes, will insure heating at the margins of the chimney thus formed. Posts, girders or braces may afford a ready access of air and promote heating at such points. Indeed, it may be noted in this connection that screenings can be successfully stored if conditions are maintained which prevent the circulation of air. The opening up of channels for a limited admission of air within the interior of such material must be avoided. In brief, there must be free circulation or no circulation of air.

3. Every possible accession of extraneous heat must be avoided. The reason has already been made obvious. A few of the possible sources of heat need only to be enumerated: hot walls or bulkheads, steam pipes, conduits carrying hot pipes or hot air, the sun's rays, etc., etc. Any interior temperature approximating 75°C. should be considered as having reached the danger line.

4. The height of piles is limited only by the increased tendency toward segregation of sizes with increase of height. Theoretically, with actual observance of the conditions of free air or no air, there is no limit to the height to which storage piles might be carried, but practically, with the added chance of violating these conditions, relatively shallow piles are safest. The height should, of course, be governed by the conditions as above emphasized. In case of doubt use moderate heights, say, from 10 to 15 ft. There is the added advantage of dissipating the heat by conduction and radiation, as also the possibility of quick removal of hot spots for use under the boilers.

5. The question of coal types has little significance compared with the importance of maximum voids as secured by screened and sized lump, accessibility of air currents and absence of extraneous heat. Any bituminous coal, with normally good storing qualities, may be stocked in a manner to insure freedom from heating. As a matter of fact, the conflicting statements often met with concerning the storage qualities of the same coal, even of coal from the same mine, are evidence of the truth of these propositions. Indeed, the same statements may be

extended to include coal mixtures, and emphasis is here intended to be put primarily upon the fundamental requirement of absence of fine material.

6. Coal in storage which has acquired a temperature of, say, 75°C., will proceed to the point of ignition unless the conditions are altered. A continuance of that temperature for any considerable length of time, a few days at most, will result in a reduction of heating value and, in case of a coal to be used for carbonization, a weakened structure in the resulting coke.

CHAPTER X

COMBUSTION OF COAL

General Principles.—The difficulties attending the complete combustion of bituminous coal are directly related to the volatile matter present. The showing of large volumes of smoke, therefore, is a sure sign of serious loss of the fuel constituents. The underlying principles furnish a sufficient explanation for the losses which accompany heavy smoke. A brief enumeration is here given:

a. At temperatures below 400°C. about one-half of the total volatile matter of bituminous coal is discharged.

b. The first distillates at these lower temperatures are composed of water vapor, oxides of carbon, some hydrogen and methane but chiefly the so-called heavy hydrocarbons, ethylene, propylene, benzene, etc., including also some compounds which are light oils and tars at ordinary temperature.

c. Under the most favorable conditions it is difficult to burn these heavier compounds without producing a smoky flame, a prerequisite being a much larger mixture of air than that required for the distillates which come off at the higher temperatures, mainly methane (CH_4) and hydrogen.

d. A high percentage of moisture, which is also discharged simultaneously with the heavy hydrocarbons, accentuates the difficulty by sudden expansion into steam and consequent displacement of air as well as by lowering the temperature of the combustion chamber while the process of vaporization is proceeding.

From this enumeration it is evident that to discharge these first distillates into a relatively cooler zone emphasizes the unfavorable conditions for combustion and results also in a condensation of some of the compounds, all of which is made evident by the appearance of dense volumes of smoke. This is always the result with house-heating appliances and is more or less

evident with all steam-generating devices which are fired intermittently.

The mechanical or physical features essential to smokeless combustion are now well understood, as the result of the elaborate experiments carried on by various investigators. The two fundamental elements involved are: first, a continuous accession of fuel by some system of automatic stoking; and second, the discharge of the volatile products into a highly heated combustion zone for accomplishing both the necessary admixture of air and the completion of the oxidation processes before coming in contact with the relatively cool surfaces of the boiler tubes.

Oxygen Supply.—One pound of pure carbon requires theoretically $3\frac{2}{12}$, or $2\frac{2}{3}$, lb. of oxygen for complete combustion. Since 23 per cent of the air by weight is oxygen, 1 lb. of carbon requires 11.58 lb. of air. For any reasonable degree of efficiency under the conditions prevailing in the average combustion device, this amount of air must be increased by at least 50 per cent. Very much depends, however, upon the distribution of air allowance. The volatile hydrocarbons, which are discharged from the fuel bed, are at a double disadvantage. Not only are they particular in the matter of temperature at which they will maintain combustion and the ready accessibility of their oxygen supply, but they are further handicapped by the fact that this oxygen supply is haphazard in amount and not easily adjusted to meet the varying requirements of the volatile matter. This is the more readily appreciated when it is remembered that any combustion processes taking place in the combustion chamber above the fuel bed must come from openings above the grates, since practically no air with free or unused oxygen can come through the fuel bed.¹ This involves numerous considerations, perhaps more mechanical than chemical, such as distribution of openings, size of combustion space, completeness of mixing and pressure of gases within the furnace, or "drafts." These considerations have a vital bearing especially upon a number of topics relating to good efficiencies in combustion, only a few of which can be referred to here.

Smoke.—It is evident from the preceding discussion that smoke reduction depends upon (a) admission of air above the

¹ KREISINGER *et al.*, U. S. Bur. Mines, *Bulls.* 135, 137, 139, 1917 and 1918.

fuel bed, (b) thorough mixing and (c) the maintenance of a temperature above the ignition point of the gases and vapors involved. Failure on the part of any one of these three conditions will result in smoke where bituminous coal is being burned. In house-heating appliances only the first condition (a) can be employed to any practical degree and this especially under the conditions of intermittent firing is, for all practical purposes, substantially lacking. Hence, as a general statement it may be said that all house-heating appliances produce smoke, and in the aggregate this smoke is more than that produced by factories and small establishments combined.

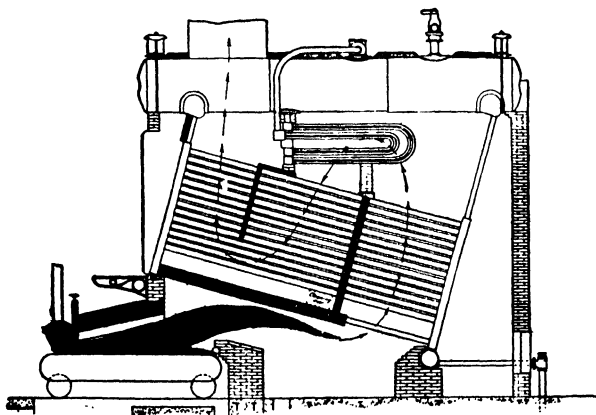

FIG. 42.—Stoker boiler showing tile baffling.

In the case of large installations the conditions under (a) and (b) are the most readily provided through the use of stokers, which avoid the intermittent conditions which accompany hand firing. A steady accession of fuel results in a uniform discharge of volatile combustible which can be met with reasonable accuracy by a definite admission of air above the fuel. Varying loads and varying draft pressures, however, complicate the problem.

Of all, the most difficult condition to meet is that under (c), or (b) and (c) combined. The ignition temperature of the more common gases discharged into the combustion chamber, such as methane for example, is from 650 to 750°C., or a mean of 700°C. (1300°F.), and for hydrogen the average value is 585°C.,

or 1085°F.¹ The temperatures of the flues in a water-tube boiler doubtless never exceed 218°C. (425°F.) at 300-lb. gage pressure.² Among the more common methods for securing the necessary temperatures are those which provide a longer combustion chamber. This may be secured horizontally, as in the tile baffling of the lower flues (Fig. 42), or by elevating the boiler above the fuel bed as shown in Fig. 43 where the extreme height between the fire and flues may average as much as 15 ft. The development of the use of preheated air and of controlled over-fire air supply has done much to eliminate smoke from industrial chimneys.

Clinker Formation.—The worst enemy of efficiency in the burning of bituminous coal is any condition of fusion or cementation of the constituents of the fuel bed, in such a manner as to impede or block off the passage of air and products of combustion through the mass. The organic matter of some coals has a tendency to fuse readily or “cake,” but this property, to the extent of interfering with the free burning of coals of the Illinois type, is not of a serious nature. A much more difficult problem resides in the tendency of these coals to clinker. Clinker, in the ordinary sense, is the fusion of the inorganic or ash constituents of the coal into masses that interfere with the free access of air. Under normal conditions, from 10 to 25 per cent of the total combustible is discharged into the combustion chamber for burning above the fuel bed. The formation of clinker tends greatly to increase this ratio. The shortage of oxygen also promotes the formation of carbon monoxide and increases the amount of unburned material passing out with the ash. Moreover, the formation of clinker tends to produce more clinker, for reasons that will readily appear. Coals with a high percentage of pyritic iron (FeS_2) have a readily melting constituent in that material. The melting point of FeS_2 is only 1171°C., and even though it decomposes with heat, the resulting compound FeS melts at about the same temperature, 1197°C. The latter compound is quite stable so far as dissociation is concerned and if nothing occurs to change its composition, it may, if present in

¹ DIXON and COWARD, *Jour. Chem. Soc.*, vol. 95, p. 519, 1909.

² MARKS and DAVIS, “Steam Tables”: Longmans, Green and Co., New York, 1929.

considerable quantity, flow down upon or through the grates, having a consistency something like molasses. If the grates

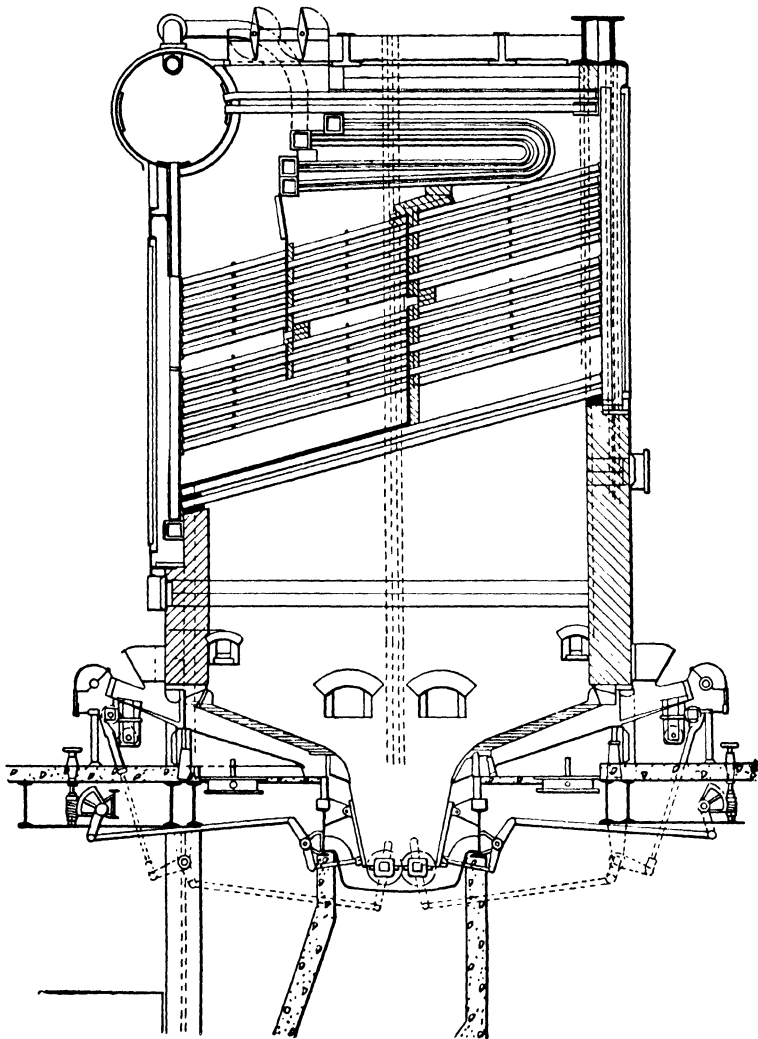

FIG. 43.—Sectional view of stoker and boiler.

become covered with such material, the cooling effect of the air is lost and the grates quickly burn out.

If, on the other hand, the conditions of combustion are kept active so that all of the sulfur is burnt and the iron oxidized to Fe_2O_3 , the fusing point of the latter is 1548°C . and that condition of complete oxidation, if accomplished, practically eliminates the possibility of clinker formation. The accomplishing of this state of complete oxidation involves, perhaps, more physical conditions than otherwise. Lump coal or sized egg or nut will retain open passage-ways and thus promote oxidation. Slack or screenings or mixed smaller sizes will impede the free access of air. Such coals in house heaters will be very prolific of clinkers. Most mechanical stokers, especially of the underfeed type, tend to keep the fuel mass broken up so that the air has access. In locomotives and fuel beds of unusual width or depth where excessive draft is essential, the carrying of smaller particles of the low-fusing constituents by means of the strong draft currents results in "honeycombing" of flue sheets or the spaces between water tubes, to such an extent that the passage-ways are seriously reduced or cut off altogether. The most obvious remedy is to increase the air supply to the fuel bed or maintain the conditions which will result in more positive oxidizing conditions whereby the resulting ash shall not have an admixture of iron in the form of FeS .¹

Fusibility of Ash.—Much importance is being placed at the present time on the fusibility of ash, and specifications covering the methods for the determination have been adopted.² There may be very little relation between the fusibility of the ash sample as made ready for such a test and the same ash under adverse conditions of combustion where insufficient air and a strongly reducing environment are maintained with a coal of high pyritic content.

The Wetting of Coal.—From the previous discussion as to the cause of clinker formation a sufficient reason is afforded for the practice of wetting down the coals before firing the same under the boiler. The larger use of screenings with the mechanical stokers now in vogue and the higher percentage of iron

¹ PARR, S. W., Honeycomb and clinker formation in locomotives: *Proc. Internat. Ry. Fuel Assoc.*, 1914.

² FIELDNER, A. C., Tentative method for determining the fusibility of ash: *Am. Soc. Testing Materials*, 1920.

pyrites in such fuel of the smaller sizes¹ make a brief reference to this practice of coal wetting desirable.

The FeS₂ of coal when it reaches the combustion zone of the fuel bed readily changes to FeS. In this condition it may be decomposed by steam. Some of the reactions involved are shown by the equation:

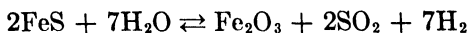

Verification of some of these conditions is afforded when a stream of water is turned on a red-hot clinker, the odor of SO₂ being very marked. Similarly, without being able to assign any reason for it, a fireman will maintain that a pool of water retained under the grates and from which the steam arises into the fuel bed will promote a better combustion of the coal. The natural argument would seem to be against the wetting of coal since the latent heat of vaporization of the added water is lost. However, the practical result of an open fire bed and a reduction of the clinkering effect decidedly outweigh the theoretical considerations against the wetting down of the coal.

Another consideration from the chemical standpoint would be as follows: Water vapor passing through or coming in contact with an incandescent fuel bed would form water gas to a very considerable extent. The gases H₂ and CO, upon recombining, would regenerate only the heat lost in their formation, but their ignition temperatures would permit of a continuation of the combustion process within the relatively cooler zones of the system, as for example in the flue spaces. The heat thus developed would promote the further burning of those hydrocarbons which require a high temperature for their complete combustion, such as marsh gas, etc. Under circumstances, therefore, where the conditions approximate those above outlined, it is entirely possible that the wetting of coal may result in an actual increase of efficiency.

Other considerations of a more physical type might be referred to. In the case of finely divided material the water-bonding effect may tend to hold the particles in place until the heat

¹ POWELL and PARR, Forms of sulfur in coal: Univ. Ill. Eng. Expt. Sta., *Bull.* 111, 1919; YANCEY and FRASER, Distribution of the forms of sulfur in the coal bed: *Ind. Eng. Chem.*, pp. 13-35, 1921.

reaches the coking or caking stage, with the result that less solid fuel is drawn through the combustion chamber into the stack without burning. Whether these explanations adequately cover the case or not, the fact remains that with the finer sizes of Illinois coals the everyday experience in the boiler room is decidedly in favor of the wetting-down process.

Pulverized Fuel.—The first attempt to use coal in the powdered form was made by Niepce¹ in 1818, but this installation as well as that of Henchel in 1831 failed, probably on account of the relatively coarse coal particles used. The first really successful application was in 1895, when the Atlas Portland Cement Company began to use powdered coal in firing cement kilns.² The rapid growth in the use of this method of combustion during the last decade makes its consideration very important.

The combustion of coal in the pulverized form is somewhat different from that on a stoker. The extreme fineness of the particles, 85 per cent of which will pass a 200-mesh sieve, presents an enormous surface on which the reactions may take place. The distillation of the volatile matter from the coal and the subsequent burning of the gases and the coke are rapid. The air necessary for combustion is mixed with the coal as it is introduced into the furnace. In some ways, therefore, the burning of powdered coal is similar to the burning of a combustible gas, a thorough mixing of the fuel with the air being essential to both. Like gas, also, the combustion is practically completed with the use of only small amounts of excess air. Boiler installations using pulverized fuel are therefore seldom the source of smoke.

The high gas velocities and the smallness of the particles in powdered fuel are responsible for a considerable portion of the ash being carried out of the stack. In congested areas this has been considered a menace, and considerable investigation has been undertaken to develop methods for dust removal. At the present time three methods are available, each of which is claimed to give good results, *viz.*: electrical precipitation, washing the gases with water, and centrifugal separation.

¹ *Ann. mines*, vol. 7, p. 176, 1875.

² HASLAM, R. T., and RUSSELL, R. P., "Fuels and Their Combustion": McGraw-Hill Book Company, Inc., New York, 1926.

Besides the larger quantities of dust carried by the gases from powdered coal as compared to those from stoker installations, the sulfur dioxide content is also somewhat higher. This is due to the more complete combustion of sulfur forms in the coal. Recent work has shown that from 60 to 70 per cent of the sulfur in coal is converted into gaseous compounds when the coal is fired on a chain grate and that this percentage is increased to from 90 to 95 per cent when the same coal is fired in the powdered form.¹ The high concentrations of sulfur dioxide in flue gases from high-sulfur coal as a menace in densely populated areas has received considerable attention in England, and its removal is now being studied in this country.

The chief advantages of firing coal in the powdered form lie in the high efficiencies, the great flexibility and the wide range of fuels which may be used successfully. Thus boilers may be operated with efficiencies of 85 per cent over a wide range of evaporation rate. High ratings are easily attainable, one company recently reporting the evaporation of more than 1,000,000 lb. of water per hour in a boiler. Coals of all types, from lignites and high-ash sub-bituminous to anthracites lend themselves to this method of firing. From the operating standpoint, the chief disadvantages have been the cost of the pulverizing and the removal of the molten slag from the furnace walls and floor. The former has been largely met by the increase in the efficiency achieved by the method and by improvements in the pulverizing process. The removal of slag in the molten form and the development of water-wall furnaces have contributed to the increasing popularity of pulverized fuel.

¹ JOHNSTONE, H. F., The corrosion of power plant equipment by flue gases: Univ. Ill. Eng. Expt. Sta., *Bull.* 228, 1931.

CHAPTER XI

IMPURITIES IN COAL

Classification.—Coal consumers are interested in four impurities which are commonly found in all coal—moisture, ash, sulfur and phosphorus. The first three are usually determined in all coal analyses, and a knowledge of the amount and character of these impurities is essential for the proper utilization of coal. The fourth impurity, phosphorus, is only of importance in the production of coke used in the manufacture of pig iron for making acid steel and is rarely determined by the chemist when the coal is to be used for other purposes. Chloride is an impurity frequently found in European coals but not in American coals, and therefore not of interest to consumers in this country.

Table XI summarizes the source of the impurities that are commonly found in coal. By far the greater percentage of

TABLE XI.—CLASSIFICATION OF IMPURITIES IN COAL

Water	{	Free Inherent Chemically combined									
Ash	{	<table style="border-collapse: collapse;"> <tr> <td style="padding-right: 10px;">Plant ash</td> <td style="font-size: 1.5em; vertical-align: middle;">{</td> <td style="padding-left: 10px;">Shale Clay</td> </tr> <tr> <td style="padding-right: 10px;">Rocks</td> <td style="font-size: 1.5em; vertical-align: middle;">{</td> <td style="padding-left: 10px;">Slate Sandstone Limestone</td> </tr> <tr> <td style="padding-right: 10px;">Minerals</td> <td style="font-size: 1.5em; vertical-align: middle;">{</td> <td style="padding-left: 10px;">Calcite (CaCO_3) Gypsum ($\text{CaSO}_4 \cdot 2\text{H}_2\text{O}$) Pyrite ($\text{FeS}_2$) Marcasite ($\text{FeS}_2$) Halite ($\text{NaCl}$) Evansite ($\text{Al}_6\text{P}_2\text{O}_{14} \cdot 18\text{H}_2\text{O}$)</td> </tr> </table>	Plant ash	{	Shale Clay	Rocks	{	Slate Sandstone Limestone	Minerals	{	Calcite (CaCO_3) Gypsum ($\text{CaSO}_4 \cdot 2\text{H}_2\text{O}$) Pyrite (FeS_2) Marcasite (FeS_2) Halite (NaCl) Evansite ($\text{Al}_6\text{P}_2\text{O}_{14} \cdot 18\text{H}_2\text{O}$)
Plant ash	{	Shale Clay									
Rocks	{	Slate Sandstone Limestone									
Minerals	{	Calcite (CaCO_3) Gypsum ($\text{CaSO}_4 \cdot 2\text{H}_2\text{O}$) Pyrite (FeS_2) Marcasite (FeS_2) Halite (NaCl) Evansite ($\text{Al}_6\text{P}_2\text{O}_{14} \cdot 18\text{H}_2\text{O}$)									
Sulfur	{	Pyrite Marcasite Gypsum Organic compounds									
Phosphorus	{	Evansite Organic compounds									

these is found in the so-called rock impurities which have been deposited as layers concurrently with the formation of the coal bed. The mineral impurities may have been deposited at the same time the coal was formed, or deposited afterward by underground waters carrying mineral salts in solution. If deposited after the coal they are termed "subsequent" impurities. The mineral impurities are not only a source of ash but also of some other important impurities, such as sulfur and phosphorus.

Moisture.—Water is found in coal in three forms—free, inherent and chemically combined. Free water is that producing wetness. Inherent moisture is that locked in the pores of the coal by capillary attraction or by forces due to a colloidal condition of the coal substance. Freshly mined coal may appear dry and dusty and yet contain as high as 25 per cent water, depending upon the rank of the coal. The amount of inherent moisture present in coal is known as the normal coal-bed moisture. In addition, a certain percentage of water exists in chemical combination with the coal and associated minerals which may amount to several per cent in the case of high-oxygen coals. Each 1 per cent of moisture present in coal represents 20 lb. of worthless material per ton of coal and, in addition, requires a considerable amount of heat for evaporation during combustion or coking processes.

Ash.—Some of the ash present in coal was derived from the plant material that originally made up the coal substance. Recent research has shown that certain plants, the bamboo type, for example, possess far more ash than others. In general, most plants have only a fraction of 1 per cent of ash but during the process of coalification the great shrinkage in mass accompanying the loss of water and organic matter caused a corresponding increase in ash mineral matter.

A microscopic study of coal reveals that very fine clay is intimately associated with most coal. This is due no doubt to silt carried by floods into the coal forming swamps and mixed with plant remains. At times the influx of silt was so great that separate bands of rocks as clay, shale and even sandstone were formed. If all the accumulation of vegetal matter took place in clear water, a coal of very low ash content would result.

Additional ash-forming materials were laid down in the coal beds during or after their formation by water carrying mineral salts of iron, calcium, magnesium, sodium and other metals which were deposited as precipitates or replacements. If deposited concurrently with the formation of the coal these impurities are usually present in very small microscopic particles. Deposition after the formation of the coal occurred along bedding planes as bands or layers, or as fillings in vertical cleavage planes and cracks, as well as in minor bedding planes.

Another source of ash is the presence of clay, shale and sand forced into the cracks and crevices of the coal bed by pressure, forming "clay veins," "mud slips," and "sand veins." Finally, there is frequently contamination by particles of roof and floor rock mixed with the coal during the mining operations.

Ash-forming impurities so intimately mixed with the coal that they form an integral part of the coal substance, as plant ash, microscopic clay and mineral matter are known as "inseparable" or "inherent" ash impurities. Coals containing a high percentage of inherent ash are gray in color. If the ash content is over 40 per cent they are known as carbonaceous shales. "Bone" coal is a term applied to coal containing from 25 to 40 per cent of inherent ash. Ash-making impurities as bands, layers, balls and veins, separate and distinct from the coal, are known as "separable" impurities.

Sulfur.—The sulfur of coal occurs in three characteristic forms, two of them inorganic and the other an organic combination. Pyrite and marcasite, having the same chemical formula but a different crystal structure, are the chief inorganic compounds. Marcasite is more readily decomposed than pyrite. It is probable that the mineral called pyrite, or "sulfur" by the miners, is really marcasite, but the term pyrite is usually applied regardless of the mineralogical differentiation of the two minerals.

Pyrite occurs as bands, lenses, balls, flakes and in particles so small as to be referred to as microscopic pyrite, most of such particles being less than 0.002 in. in diameter. Pure pyrite contains 46.6 per cent iron and 53.4 per cent sulfur. The amount varies considerably, even locally in the same coal bed.

The other inorganic form is gypsum. It occurs in small and varying amounts as white flakes along the parting and cleavage

planes of the coal. The amount of sulfur present in this form is usually very low, amounting to only a fraction of 1 per cent in fresh coals. In weathered coal a higher percentage of sulfur in the sulfate form may be present because of the ease with which pyrite weathers to this form.

Two forms of organic sulfur are recognized, namely, resinic and humus. Resinic organic sulfur is present in that part of the coal substance which is soluble in phenol and is shown to be organic in nature by its lack of an ash. Humus organic sulfur is that part of the organic sulfur remaining in coal after the resinic sulfur has been removed by phenol extraction. It may be shown to be closely related to humus substances by chemical action. Table XII gives the percentage of the various

TABLE XII.—FORMS OF SULFUR IN COAL AND RESIDUAL SULFUR REMAINING AFTER COKING
(Values given in per cent)

Sample No.	Total sulfur	Sulfate sulfur	Pyritic sulfur	Resinic sulfur	Humus sulfur	Residual sulfur
5a	1.08	0.00	0.31	0.16	0.61	0.34
6a	4.00	0.00	2.06	0.77	1.17	1.46
7	3.31	0.31	1.30	0.50	1.20	1.37
7a	3.00	0.00	1.30	0.50	1.20	1.09
10	0.95	0.02	0.10	0.13	0.70	0.45
10a	0.93	0.00	0.10	0.13	0.70	0.38

These sulfur forms were determined by the methods of Powell and Parr.¹

Suffix *a* indicates coals were extracted with dilute hydrochloric acid before coking. It is of interest to note the difference between the amounts of residual sulfur in these coals as compared with the amounts in the corresponding coals which had not been extracted.

¹ POWELL, A. R., and PARR, S. W., A study of the forms in which sulfur occurs in coal: Univ. Ill. Eng. Expt. Sta., *Bull.* 111, 1919.

forms of sulfur as found in several samples of coal, and also that remaining in the coke from these coals, which is known as residual sulfur.

Phosphorus.—This impurity is always present in coals in very small amounts. It is of importance only in the production of

low-phosphorus blast-furnace coke. It usually occurs in organic combination although small amounts of the mineral, *evansite*, have been noted in some coals. It is not possible to remove phosphorus to any extent by coal-cleaning methods but it is frequently found concentrated in certain benches of coal, so that, by selective mining, the phosphorus content of the coal can be kept at a minimum. This involves careful sampling and analysis of the coal-bed benches as mining progresses.

Distribution of Ash and Sulfur in Sizes.—Usually there is a concentration of ash and sometimes of sulfur in the fine sizes, depending on the relative friability of the coal and refuse material. Some coal beds have a considerable amount of impurities deposited as thin bands, flakes and streaks along bedding and cleavage planes. Since such impurities are more or less freed from the coal during mining operations, they are concentrated in the fine sizes which, as a result, have a high ash content.

TABLE XIII.—DISTRIBUTION OF IMPURITIES IN THE COAL BED
(Number 5 coal, La Salle County, Illinois¹)
(Values given in per cent)

Sample No.	Moisture	Ash	Total sulfur	Sulfate sulfur	Pyritic sulfur	Organic sulfur
Ia	12.95	14.58	4.04	8.08	2.00	1.96
IIa	11.61	15.69	5.51	0.14	3.63	1.74
Ib1	13.45	7.70	1.97	0.04	0.89	1.04
Ib2	14.32	8.69	3.56	0.05	1.82	1.69
Ib3	13.22	12.96	2.78	0.05	1.26	1.47
Ib4	12.85	17.31	4.06	0.05	1.61	2.40
IIb1	6.47	17.59	5.56	0.10	3.40	2.06
IIb2	11.37	10.19	3.71	0.07	2.12	1.62
IIb3	2.97	61.33	41.70	0.38	40.26	1.06
IIb4	10.32	20.66	9.72	0.31	6.97	2.44
IIb5	12.95	13.36	5.52	0.16	3.35	2.01

Suffix *a* indicates complete channel sample.

Suffix *b* indicates increment samples; see Fig. 44.

¹ CALLEN, A. C., and MITCHELL, D. R. Univ. Ill. Eng. Expt. Sta., *Bull.* 217, p. 35, 1930.

Distribution of Impurities in the Coal Bed.—Figure 44 shows two face sections of No. 5 coal in northern Illinois. This is a high-sulfur coal and the distribution of impurities, as shown by these sections, is typical of most coals of this nature. In addition to the impurities shown, calcite and gypsum are present in practically all vertical cleavage planes as thin white flakes.

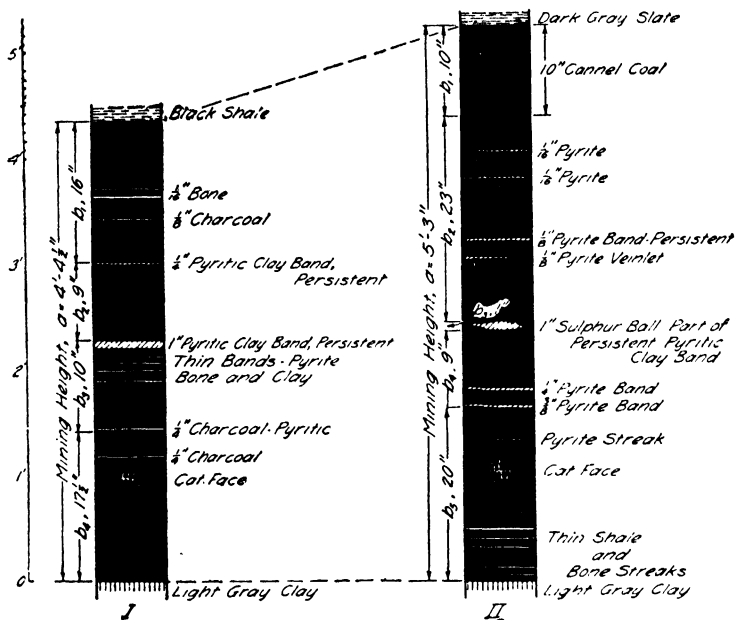

FIG. 44.—Face sections of No. 5 coal, LaSalle County, Illinois.¹

This coal was sampled by taking a complete channel at these sections. Then the bed was divided into benches and each bench sampled. These samples were analyzed in the laboratory and the results are given in Table XIII. Ash and pyritic sulfur vary considerably in the different benches, the sizes of which and the impurities present are shown in Fig. 44. The important fact to note in this table is the very slight variation in organic sulfur. The total sulfur varies directly with pyritic sulfur present, while the organic sulfur changes very little. This

¹ CALLEN, A. C., and MITCHELL, D. R., Washability tests of Illinois coal: Univ. Ill. Eng. Expt. Sta., *Bull.* 217, p. 33, 1930.

holds true for nearly all coals. A low-sulfur coal contains most of its sulfur in the organic form. Exceptions to this condition have been noted but they are rare.

Table XIV gives some interesting information on the distribution of the various sulfur forms in float-and-sink fractions of

TABLE XIV.—SULFUR DISTRIBUTION AND ASH OF SELECTED FLOAT-AND-SINK FRACTIONS
(Moisture free)
(Values given in per cent)

Size	Fractions	Sulfate sulfur	Pyritic sulfur	Organic sulfur	Total sulfur
3 × 1½ in.....	1.30 Float	0.02	0.88	2.01	2.90
	1.30-1.35 Float	0.04	1.69	2.05	3.78
	1.35-1.40 Float	0.05	2.21	1.85	4.11
	1.40-1.50 Float	0.07	3.37	2.11	5.55
	1.50-1.60 Float	0.10	6.40	2.49	9.00
	1.60-1.70 Float	0.25	9.12	1.68	11.05
	1.70 Sink	0.43	26.07	0.60	27.10
1½ × ¾ in.....	1.30 Float	0.02	0.87	2.18	3.07
	1.30-1.35 Float	0.06	1.56	1.32	3.25
	1.35-1.40 Float	0.08	3.13	1.77	4.98
	1.40-1.50 Float	0.09	3.20	2.25	5.54
	1.50-1.60 Float	0.14	5.30	2.10	7.54
	1.60-1.70 Float	0.17	5.54	1.89	7.60
	1.70 Sink	0.37	21.00	1.03	22.40
¾ × ¼ in.....	1.30 Float	0.02	0.80	2.76	3.58
	1.30-1.35 Float	0.02	1.25	4.16	5.43
	1.35-1.40 Float	0.05	2.34	3.54	5.93
	1.40-1.50 Float	0.06	2.92	3.28	6.26
	1.50-1.60 Float	0.09	4.57	2.72	7.38
	1.60-1.70 Float	0.13	5.18	1.42	6.73
	1.70 Sink	0.34	12.95	5.01	18.40
⅛ in. × 20 mesh.	1.30 Float	0.02	0.72	2.27	3.01
	1.30-1.35 Float	0.04	1.17	2.12	3.33
	1.35-1.40 Float	0.05	1.65	1.72	3.42
	1.40-1.50 Float	0.06	2.30	1.61	3.97
	1.50-1.60 Float	0.09	3.31	2.37	5.77
	1.60-1.70 Float	0.18	3.34	2.32	5.75
	1.70 Sink	0.39	7.00	1.65	9.04

certain sizes of the same coal in Fig. 44. The progressive increase of total sulfur from the lightest fraction analyzed, or the purest coal, to the heaviest fractions, or refuse, is paralleled by the increase in pyritic and sulfate sulfur. On the other hand, the organic sulfur, except for one size ($\frac{3}{4}$ by 1 in.), shows a concentration in the cleanest coal.

CHAPTER XII

COAL CONTRACTS

Introduction.—It is not the purpose of this chapter to take up the entire question of coal contracts, but only that portion of it that deals with the technical specifications incorporated in the contracts for steam coal.

The practice of buying coal on a technical specification basis is one that has grown up within the last 30 years. Within the same period has developed modern preparation practice. The coal mining industry has been making a determined effort to supply the consumer with the sizes he wants, and in recent years has devoted more and more attention to furnishing coal that has been cleaned by hand or mechanical means. Today, coal supplied by the modern producer can be obtained in a variety of sizes—some tipples can make over 20 sizes, and with a low and uniform percentage of ash. The result has been that the coal consumer can secure the kind of coal he needs, and in sizes and with ash percentages that will give the best results in his equipment and under his conditions of use. It is almost literally true that every ton of coal sold in this country is sold on some kind of a specification basis, for at least the kind and size of coal desired are specified.

But the purchase and sale of coal on a technical specification basis generally involve the incorporation in the contract of guarantees of heating value, ash, moisture and sulfur content, and frequently of the fusion point of the ash. In addition, there are usually certain limits of variation from the standard within which the coal will be accepted, and methods of computing the penalties or premiums to be applied to the contract price to care for variations in the quality of the delivered coal. Millions of tons of coal are purchased annually on such technical specifications, popularly called “the B.t.u. basis.”

Much opposition has grown up in some quarters, mainly on the part of some producers, to this practice. Indeed the general manager of sales of one of the largest coal companies in the United States has just declared that "the American coal producer is unalterably opposed to the sale or purchase of coal on a B.t.u. basis." Similar statements appear from time to time. A casual reading of the presentation of the critics of the technical specification method will frequently leave a strong impression. Careful study of such criticisms will generally reveal that the method is condemned because of one or more of the following:

1. The producer has not known his own coal sufficiently well to make an intelligent bid.
2. The consumer has specified coals that do not exist, or analyses so rigid that no mine could meet them, or penalties out of all proportion to his damages.
3. Analytical methods are supposedly at fault.
4. Much sampling is done in a careless or improper way and analyses of such samples mean little or nothing.
5. Proper sampling is rather arduous and expensive.

All of these alleged reasons for condemning the technical specifications are, if and when true, serious objections to the method, but there is no valid cause for any, except the last, to be true.

Buyer and Seller.—A coal contract, like all other contracts, presupposes a "meeting of minds." If there has been a real meeting of minds, then the purchase and sale of coal on the basis of technical specifications offer no difficulty; if not, trouble and hard feelings are likely to result.

The buyer should not prepare specifications until he has ascertained by plant tests the kind and size of coal best adapted to give most efficient results under his conditions of use. Such tests may even lead him to change his conditions so as to use a different type or size of coal. Then he is in position to specify what he wants, and to prepare a scale of premiums or penalties that will take care of the savings or expenses resulting from the delivery of a fuel other than the standard. Even then, he should not resort to too technical specifications unless the cost of proper sampling and analysis can be justified in terms of results secured.

The seller should know his coal. He should know its unit coal value, the variations in ash and sulfur, the bed moisture, the percentage of volatile matter and the fusion temperature of the ash. If he knows his coal thoroughly then, and only then, is he prepared to make intelligent bids on a specification basis.

Both buyer and seller must understand the need for accurate sampling and accurate analysis. Standard methods of sampling and analysis should be included in the contract, as well as the qualifications of the sampler and the chemist. Faulty samples taken by unsupervised common labor are worse than useless for they are not worth analyzing. Good samples analyzed by an incompetent technician are equally worthless. Standard sampling and analytical methods, such as those of the American Society for Testing Materials, and competent samplers and analysts are essential.

Basis for Specifications.—The general reason for specifications of all kinds is the desire to obtain a uniform supply of the right material at a proper price. There is no reason why coal cannot be purchased under an arrangement that will satisfy such a desire, provided the buyer and seller are well informed, the former as to his needs and the latter as to his product.

If the purchaser has previously decided on the general kind of coal best suited to his plant, with regard to the content of volatile matter, the fusibility of ash and the proper size of coal, the most important item in the specification is the heating value of the coal.

The heating value becomes the best single criterion because for a given coal bed and locality it is essentially a constant for the pure coal substance, variations in the heating value of the commercial coal being due to variations in moisture, ash, and to a lesser degree, sulfur. For a given kind and size of coal, the value varies essentially in direct proportion to the calorific value, and variations in quality cause corresponding variations in the price which the fuel is worth.

Ash affects the heating value directly; but, if this were its only effect, no account need be taken of the ash as such, for the variation would be allowed for in the adjustment for calorific value. However, increased ash causes additional expense for handling and disposal as well as a decreased efficiency. For this reason an additional penalty for high ash is generally specified,

varying from a moderate penalty in some specifications to a very severe one in others. This is frequently referred to as the "double ash-penalty," and has often been criticised.

Double Ash-penalty.—A fair double ash-penalty can be justified. The additional cost of handling and removal has been mentioned, but the decrease in efficiency caused by high ash needs some further substantiation.

To illustrate this in a simple way reference is made to Fig. 45. This curve is reproduced from a paper¹ by W. L. Abbott describing extensive tests made with Illinois screenings. His

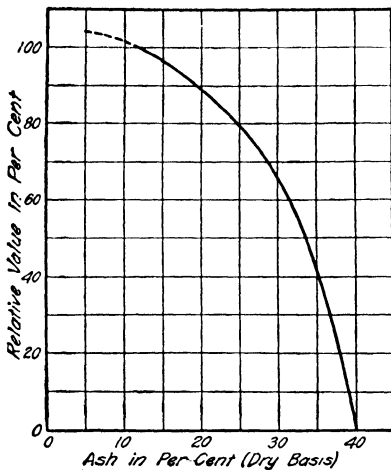

FIG. 45.—Effect of ash on relative value of fuel.

results showed that if coal with 12 per cent ash (dry basis) were taken as having a relative value of 100 per cent, then coals with greater percentages of ash had rapidly decreasing relative values, until at 40 per cent dry ash they were worthless for steam-raising purposes. The extrapolation of the curve indicates that coals with less than 12 per cent of dry ash would have relative values somewhat greater than 100 per cent. It is not intended

to imply that this curve can be applied for all coals or all types of equipment, but the general effect of increased ash is unquestionably to produce a lower relative value.

Furthermore, large users of coal have found that better plant results are secured by having coal that is uniform in ash content, rather than having shipments with great variations even though they might average the specified ash.

Anyone who carefully evaluates these several factors cannot escape the conclusion that the double ash-penalty, if properly calculated on the basis of actual effect on plant costs, is fully warranted.

¹ *Jour. Western Soc. Eng.*, vol. 11, p. 529, 1906.

Other Variables.—Moisture was formerly a more important feature of specifications than it is now. Unless the coal is intended for a special purpose where the moisture must be below a certain limit, there is little use in including a moisture specification. The reason is that it directly affects the heating value and the correction is made there. Since payment is generally made on delivered weights and the B.t.u. determinations are made on the "as received" basis, the price adjusted thereon is fair to both buyer and seller.

In general, it is not necessary to specify definite limits for volatile matter unless the plant cannot burn efficiently coal of certain volatile content, or unless local smoke ordinances make a low-volatile coal necessary with the particular plant equipment. The quality of the volatile matter is taken care of in the calorific value of the fuel.

Sulfur specifications are often relics of specifications dealing with metallurgical fuel, where sulfur must be kept low. There is still no general agreement as to the effect of sulfur on the fusion temperature of the ash, but it is commonly considered to have less effect than was formerly supposed. Recent studies have shown that pyritic sulfur is largely responsible for corrosion in plant equipment and that atmospheric pollution by sulfur compounds in stack gases may be very undesirable.

Within recent years a standard method for the determination of the fusion temperature of ash has received the approval of the American Society for Testing Materials. There is still doubt as to the exact correlation between such determinations and the behavior of the coal when burned. It is not advised that rigid specifications as to the fusion point of ash be made, unless plant tests have shown the necessity therefor and have indicated the correlation between the laboratory determination and the results in the plant.

More and more attention is being given to the size of coal best suited for a given plant, and the effect produced by too large a proportion of fine coal. It is not uncommon for the buyer to request or specify a guaranteed limit for percentage of coal smaller than a given size (usually coal passing a $\frac{1}{4}$ -in. round-hole screen).

Invitations for Bids.—Many different specifications are in use by purchasing officers. This is to be expected, owing to the wide diversity of requirements. Here it will be possible to treat a general case only, indicating some variations that are common.

For the general case, it will be assumed that an invitation for bids gives the kind, size and, perhaps, origin of the coal required. The origin—state, county, mine and name of coal bed—may, of course, be inserted by the bidder. The method of comparison of bids for computing settlement prices is also given.

1. The bidder guarantees that the coal he proposes to furnish shall approximate a given percentage of moisture, a given percentage of ash and a given number of British thermal units per pound, as delivered, and quotes a delivered price per ton.

2. From these data the buyer computes the net B.t.u. for 1 ct. represented by the guaranteed analysis on the basis set forth in the invitation for bids.

3. The bidder offering the greatest number of net B.t.u. for 1 ct., provided all other conditions are met satisfactorily, is awarded the contract.

4. Settlement for coal delivered under the contract is made at the contract price provided deliveries are within a range of, say, 2 per cent above or below the guaranteed heating value or percentage of ash. If the given range is exceeded then corrections are applied to the contract price, the amount of the corrections being computed in the manner set forth in the invitation for bids.

Comparison of Bids.—While specifications from different sources vary in the requirements for the giving of analytical data, some asking for data on the “dry” basis, some on the “as received” basis and some partly on one and partly on the other basis, yet this need cause no confusion. If the delivered or “as received” data are given, then the “dry” values are easily computed. In spite of the variations in form, the actual comparisons of bids are usually made on what may be called the “warranted net B.t.u. for 1 ct.” The word “warranted” is used here because the computation is based on the bidder’s warranted analysis. “Net” implies that an additional correction is made for ash—the double ash-penalty.” The price used is the delivered price, whether the bid is on the delivered basis or f.o.b. mine.

TYPICAL FORMULAS FOR CALCULATING WARRANTED NET B.T.U. FOR 1 CT.¹

1.
$$\frac{\text{Delivered B.t.u.} \times 2,000}{P + A}$$
2.
$$\frac{\text{Delivered B.t.u.} \times 2,000}{P + \frac{1}{2}A}$$
3.
$$\frac{\text{Delivered B.t.u.} \times 2,000}{P \left(1 + \frac{A - 5}{200} \right)}$$

An example of the results given by these three formulas, applied to the same bids, is given in Table XV.

The B.t.u. for 1 ct., as obtained by dividing the B.t.u. in a ton of delivered coal by the price, is given in the last line for comparison with the other calculated values. It will be noted

TABLE XV.—COMPARISON OF BIDS FOR COAL CONTRACTS

Item	Bid I		Bid II	
	As received	Dry	As received	Dry
Moisture, per cent.	10.00	5.00	
Ash, per cent.	8.00	8.80	10.00	10.53
B.t.u. per pound.	11,850	13,170	12,300	12,950
Price per ton.	\$6.00	\$6.15	

Formula	Warranted net B.t.u. for 1 ct.		Difference, B.t.u.
	Bid I	Bid II	
1	38,920	39,330	410
2	39,210	39,660	450
3	38,750	38,930	180

¹ These formulas are simplified from the actual wording of the specifications, which, while using dry B.t.u., yet actually calculate back to the delivered B.t.u. No. 1 is from an important commercial fuel laboratory; No. 2 from a large county in a mid-west state; No. 3 from a mid-west state. P = price in cents per ton; A = percentage of dry ash.

TABLE XV.—COMPARISON OF BIDS FOR COAL CONTRACTS (*Continued*)

	Warranted gross B.t.u. for 1 ct.		Difference, B.t.u.
	Bid I	Bid II	
$\frac{\text{Delivered B.t.u.} \times 2,000}{P}$	39,500	40,000	500

that the calculations from the formulas give results that are somewhat less than the warranted gross B.t.u. for 1 ct. This is due to the inclusion of the ash term in the formula, the "double ash-penalty." It will also be seen that the difference between the values for the two coals as given by the formulas is less in each case than the difference obtained by the simple calculation. These differences show the effect of the double ash-penalty, stepping up the relative value of coal I on account of its lower ash. Coal II is shown to be the best coal in each calculation.

Acceptance Limits.—Certain variations from the guaranteed analysis are usually permitted before the delivered coal may be rejected. In the three specifications used as examples, the limits are as follows:

Specification No.	Analysis limits ¹	Size limits ¹
1	Dry ash.....3% greater Moisture.....5% greater Dry B.t.u.....500 less	No increase over guaranteed bid allowed in percentage passing a ¼-in. round-hole screen
2	Dry ash.....3% greater Moisture.....3% greater Dry B.t.u.....500 less	No increase over specifications allowed
3	Limits are given in excess of which bids will not be considered, and if coal is furnished on the contract in excess of such limits it will not be accepted	No specific provision for rejection for excess fines

¹ Acceptance in excess of limits is optional.

Computation of Settlement Price. *Specification 1.*—If the net B.t.u. for 1 ct., as calculated from analyses of coal delivered in a given month, do not show a fluctuation from the warranted net B.t.u. for 1 ct. of more than 2 per cent above or below, then the settlement price per ton for the month is the contract price per ton. If the fluctuations are greater than this, then the delivered value is calculated for each case by the formula

$$\text{Delivered value (in cents per ton)} = \frac{\text{delivered B.t.u.} \times 2,000}{\text{warranted net B.t.u. for 1 ct.}} - \text{dry ash per cent}$$

The average of these delivered values for the month is then taken as the settlement price per ton.

Specification 2.—The delivered value per ton for the month's shipments is computed as follows:

$$\text{Delivered value (in cents per ton)} = \frac{\text{average delivered B.t.u.} \times 2,000}{\text{warranted net B.t.u. for 1 ct.}} - \frac{1}{2} \text{ dry ash per cent}$$

and this becomes the settlement price per ton if equal to or less than the contract price. If the delivered value is greater than the contract price, the contract price only will be paid, and the excess net B.t.u. delivered in that month will be credited in favor of the bidder and applied to the liquidation of any penalty which would otherwise be enforced for a deficiency in any month or months.

Specification 3.—This specification applies a detailed series of corrections to the contract price in order to obtain the settlement price. They are summarized as follows:

a. Moisture.—No corrections for variations of 2 per cent above or below guarantee. If limits are exceeded the price is adjusted at a premium or penalty of 4 cts. per ton for each whole per cent, or majority fraction thereof, below or above the no-correction limits.

b. Sulfur.—Neglected unless it exceeds proposal by 1 or more per cent. If such coal is not rejected, the price is reduced 5 cts. per ton for each whole per cent increase, or majority fraction thereof, above that specified in the proposal.

c. Heating Value.—No adjustment for coal having a dry B.t.u. value within 200 B.t.u. of that specified in the proposal. Beyond these limits the settlement price is increased or decreased 4 cts. per ton for each 100 B.t.u., or majority fraction thereof, that the coal exceeds or falls short of the no-correction limits.

d. Ash.—Coal with dry ash less than specified in the proposal will be paid for at an increase of 4 cts. per ton for each whole per cent difference. Coal with ash not more than 2 per cent greater than specified in the proposal will not be penalized. Above this limit the cumulative penalty is 2 cts. per ton for the first whole per cent, or fraction thereof, 4 cts. for the second, 7 cts. for the third, 12 cts. for the fourth and 18 cts. for the fifth, provided the maximum limit is not exceeded. Above the maximum limits the coal, if not rejected, will be penalized 64 cts. per ton. The maximum limits for dry ash are:

Proposal Guarantee, Per Cent		Maximum Limit, Per Cent
5	12
6	13
7	14
8	14
9	15
10	16
11	16
12	17
13	18
14	19

It is self-evident that Specification 3 applies a double ash-penalty, but it is not so apparent that Specifications 1 and 2 really include such a penalty.

Taking Specification 1 as an example, an algebraic transformation shows that the settlement price can be reduced to the form

$$\frac{PB'}{B} + \left(\frac{AB'}{B} - A' \right)$$

where P is the contract price in cents per ton, B the guaranteed and B' the delivered calorific value on the "as-received" basis, and A and A' the percentage of dry ash guaranteed and delivered, respectively.

If settlement price were based on delivered B.t.u. only, it would be

$$\frac{PB'}{B}$$

The double ash-correction for this specification is then $(AB'/B) - A'$, or approximately the difference between the guaranteed and delivered dry ash expressed as cents per ton, being a penalty or a premium depending on whether the delivered ash percentage is higher or lower than the guarantee.

To show the variations in settlement price when figured according to these three methods, it is assumed that Bid II, mentioned above, was accepted, but that during a given month the average analysis of the deliveries showed the following results:

Average analysis	As received	Dry
Moisture, per cent.	8.0	
Ash, per cent.	15.0	16.3
B.t.u.	11,140	12,110

The settlement prices per ton would be as follows, providing the coal was accepted:

Specification 1	\$5.502
Specification 2	\$5.536
Specification 3	\$5.230

It will be noted that the settlement price under Specification 3 is the lowest, because of the high penalty for ash in excess of the limit. If the dry ash had been 16.0 instead of 16.3 per cent, the settlement price would have been \$5.440 per ton.

Formulation of Proposals.—The invitation for bids and the specifications that accompany them are usually clear and explicit. The seller of coal, as has been mentioned, should know his coals so thoroughly that he can determine with reasonable accuracy how closely he can meet the specifications. He must have a knowledge of the mine and its mining and preparation methods as they affect the quality and uniformity of the deliveries. Records of analyses of car samples over a period of time will aid

in determining these variations, as well as giving data for the calculation of the unit coal heating value. This may be computed from the formula given in Chapter VI, page 50.

Knowing the unit-coal B.t.u., the dry or delivered heating value may be computed if the moisture, ash and sulfur percentages are known.

$$\begin{aligned} \text{Dry B.t.u.} &= \text{unit B.t.u.} \times [1.00 - (1.08A + 0.55S)] + 5,000S \\ \text{Delivered B.t.u.} &= \text{dry B.t.u.} \times (1.00 - M) \end{aligned}$$

Calculations made on the basis of unit-coal B.t.u. should give results that are quite satisfactory for making bids, the computed heating value of the dry or delivered coal usually being accurate within a variation of 1 per cent or less of the value that would be obtained by combustion in the bomb calorimeter. It is quite evident, however, that it is absolutely necessary to have accurate knowledge of the average moisture, ash and sulfur content of the coal from the given mine, and how much variation can be expected. With such knowledge, and with proper control of mining and preparation methods, a producer should have no difficulty in making bids and furnishing satisfactory deliveries on a specification basis. Without such knowledge and control the chances are that he will suffer more or less heavy penalties.

It may be mentioned in passing that the increased use of mechanical cleaning processes is making available coal of more uniform composition. Such coal-cleaning processes are used not only to make a good coal by removing ash and sulfur from the product of a seam containing many impurities, but are also used to produce a uniform-quality coal from a good bed. For example, the coal shipped from a given mine in a month might average 8 per cent ash, but the individual cars might run from 6 to 12 per cent ash. If the mined coal were treated in a cleaning plant it might be possible to ship regularly a 7 per cent ash product, with variations of not more than 1 per cent. Such a coal is more desirable in the plant and should command a higher price. The company producing such coal is likely to have little trouble in meeting its guaranteed analysis month after month without penalty.

Attitude of Buyer and Seller.—A considerable change has taken place in the attitude of the buyer and seller, as experience has

been gained in contracting for coal on a specification basis. Years ago many specifications were prepared without proper basic information, and even with the hope of getting a good coal at a reduced price by the enforcement of penalties. The seller was quick to resent such specifications, partly because his lack of detailed knowledge of his coal resulted in guarantees which he was unable to fulfill, and as a consequence he suffered heavy penalties.

Today, specifications are fair and the seller knows his coal. Large and small consumers report no antagonism to specifications on the part of coal companies, and few if any disputes in settlement. As the purchasing department of a great industry puts it:¹

“The tolerances we allow in our contract we feel are liberal, and if a true base analysis is guaranteed, with proper preparation at the mines, there should be no need for premium or penalty.”

Fair specifications based on an accurate knowledge of plant needs and costs, fair bids based on an accurate knowledge of mine products and costs, plus a real “meeting of minds” of the buyer and the seller should make, and indeed are making, the purchase on a technical specification basis just as satisfactory a method for coal as for a great list of other products.

Selected References

- HOWATT, JOHN, *Jour. Western Soc. Eng.*, vol. 24, pp. 535-556.
SMITH, M. B., *Mech. Eng.*, vol. 49, pp. 1063-1066.
WADLEIGH, F. R., *Coal Age*, vol. 6, pp. 338-340, 422-425.

¹ Personal communication.

CHAPTER XIII

SMOKE

Reference has already been made in Chapter II to the transition from non-smoke-producing fuels to those of the decidedly smoke-producing type. It is in consequence difficult at present for dwellers in industrial regions to imagine a time or a populous center anywhere in the United States where the sum total of smoke-producing bituminous fuel amounted to less than 2 per cent of all fuels used. Only by the aid of such a backward glance are we able to arrive at any adequate appreciation of the phenomenal accomplishments in the use and utilization of fuels which have characterized the past 100 years. If we were to enumerate some of the outstanding features which have attended this fuel development we would note:

1. The estimates already noted of a third of a million tons of coal per annum 100 years ago for the entire United States, represents about one-fiftieth ton per capita. From this status we have advanced to a total of 550,000,000 tons, being about 5 tons per capita. Of this tonnage about 17 per cent is anthracite and the balance is bituminous coal.

2. The types of fuel have so changed that instead of 98 per cent of the total being non-smoke-producing, we have arrived at a stage where the smokeless variety has practically disappeared from the field and we are now consuming various fuels, approximately 90 per cent of which are smoke making.

3. The advance in efficiencies in the power plant has been commensurate with the enormous expansion in volume. This feature is to be credited to the engineer whose efforts can readily be noted in more scientific boiler settings, improved stokers, turbine engines, pulverized coal, superheaters, economizers and high boiler pressures. One might think that the engineer had nearly reached his limit but more likely he has just made a good beginning, provided he calls in the chemist for cooperation in the next combustion problem.

4. There still remains however the smoke evil, which has left its mark in more ways than one. This, of course, is an inevitable

result of the increase in the use of bituminous coal, especially in household appliances, which are credited with the production of approximately 52 per cent of the total smoke discharged into the atmosphere.¹

The Smoke Evil.²—Why should there be smoke? A brief analysis of the situation may be helpful. The ignition temperature of marsh gas is between 650 and 700°C., a temperature corresponding to a bright cherry red. Ethylene requires about 300°C. for ignition. These two are some of the more common gaseous products evolved from the bituminous coal when heated, and it is obvious that if in the process of the burning of a mass of coal they are supplied with insufficient oxygen for their complete combustion, or if, while in the process of burning they strike a sufficiently cooler surface to lower their temperature below the ignition point, their function is altered from heat producers to smoke producers. These factors may be controlled in a very effective manner in the steam-generating plant by such devices as slow and evenly distributed additions of coal, or by special setting of the boiler; hence the modern mechanical stoker and the elevated or elongated boiler settings to provide both space and time for the combustion of gases before cold surfaces are encountered. So far as the steam-generating plant is concerned, therefore, the production of great volumes of smoke is an unnecessary extravagance, inefficient, wasteful, unsanitary and avoidable. The case, however, with the average household or apartment heating unit is entirely different. Here the high heats do not prevail. The mechanical stokers as well as the liberal combustion spaces are absent. Moreover, the man of the house or the janitor has other duties to perform, whereupon he fills the combustion chamber to the limit and sets the dampers for a prolonged period of automatic control, during the major part of which period the so-called heater is simply a device for stewing off tars and vapors of inconceivable variety as to composition, odor and filth for the effective work of polluting the atmosphere. In the very nature of the case, such conditions must exist and continue to prevail in any household appliance where raw coal is fed into the furnace. No matter by what name the furnace or the coal is known, by any other name they would smoke just the same. And the worst part of the picture is not fully presented until mention is made that, as a result of exhaustive studies in many con-

¹ Goss, W. F. M., Special commission on investigation of smoke abatement: Chicago Assoc. Commerce, 1911-1915.

² PARR, S. W., Some combustion problems and their relation to health, Presidential address, St. Louis meeting, American Chemical Society, 1928: *Ind. Eng. Chem.*, vol. 20, p. 454, 1928.

gested centers, it has been demonstrated that the major part of the smoke nuisance has its origin in the domestic chimney and in the larger units of flat and apartment buildings where combustion conditions in the furnace are substantially as described above. These chimneys are guilty both because there are more of them and because they are all always on the job.

Sanitation of the Air.—We have made marvelous advances in cures for human ills, in bacterial control, in hygiene and sanitation so far as water and waste are concerned, but sanitation of the air stands today just where it did 100 years ago. In fact, air sanitation is in a worse plight, for the discharge into the air annually of smoke and sulfur and ash particles, and grime generally, from 1,500,000,000 tons of coal has been met by practically nothing in the way of remedy. Recognition of the distress is of long standing. In 1580 Queen Elizabeth prohibited the burning of coal in London during the Parliamentary season for fear "the health of the knights of the shire might suffer during their abode in the Metropolis." The first smoke-abatement commission was organized by the British Government 240 years later. A recent estimate of the annual deposit of soot for the city of London gives for each adult male inhabitant an amount substantially equivalent to his own weight of carbon. Smoke surveys have also been conducted in almost every large city in this country with fairly comparable results. One inaugurated in Chicago in 1912 found a decided smoke evil there. It is still there. The same might be said of Pittsburgh, of Cleveland, of Indianapolis, of Salt Lake City, St. Louis, and so on and on. If any one desires to revel in statistics relating to added expense of living because of laundry costs, deterioration of merchandise and material in general, to lowered efficiency, and to promotion of human ills, especially and specifically chargeable to the filtering out of the ultraviolet rays of the sun by reason of the very effective smoke screen, it is all in the printed reports of the surveys and the literature. We are here and now only interested in the fact of a positive and overwhelming unsanitary state of the air in every large city. Here is an illustration: Assuming a sulfur content of less than 2 per cent for this type of fuel, you may see, by the exercise of a little mental arithmetic, that from the burning of 1,500,000,000 tons there would be discharged into the atmosphere over 50,000,000 tons of sulfur dioxide or 100,000,000,000 lb. This being in gaseous form, it would be more appropriately expressed in cubic feet and the number would be roughly 1,000,000,000,000 cu. ft. of the pure gas. If now we assume this concentration to be reduced by dilution with air to the limit of toxicity for plant life, say, one to ten parts per million, we arrive at a figure that is meaningless by reason of pure magnitude.

Fortunately, one method of sanitary regulation of the air is still in operation—a good shower now and then will wash the air free from the pollution. This is a case where Heaven helps those who do not help themselves. Sometimes we can run away from the evil by taking a trip far into the country, or into the north woods, or an ocean voyage, but for the most of us such a remedy is more drastic in some of its phases than the ill itself, and so we bear it.

A certain dwelling is recalled far removed from possible contamination by gases from coal fires, where the window screens have remained continually in place for 20 years. The iron wire of which they are made is still whole and sound, whereas the iron wire screens of another dwelling in the center of the soft-coal belt corroded and fell completely out of their frames after one winter season. Now some of us may have our internal anatomy plated with platinum or chromium—some of us have constitutions like iron, but even so we may be easily attacked by some things. It might be well to recommend as a topic for research the cause of common colds—the effect upon the mucous tissues of sulfur dioxide gas.

What about the future? Is there any relief in sight? Will all of the next 100 years be required to undo some of the misfortunes which have befallen us, along with the marvelous developments of the 100 years just passed? Some of the hopeful features of the case are:

1. Public intelligence is growing.
2. Scientific and investigational activity have made wonderful advance in this direction in very recent years.
3. Fuel research the world over is being promoted today as never before by both government and private agencies.

The question of profound interest in these passing days relates to the transfer of these facts from the realm of theory to that of practicality and established service.

Let it be noted finally that the ideal fuel as a heating medium is gas. Its smokeless combustion, relative freedom from sulfur compounds, high efficiency, cleanliness and convenience give it a status unapproached by any other type of fuel. When it reaches the stage of volume production to an extent where costs can be materially reduced, the extension of its use will be greater than can be remotely realized at the present time. We shall welcome and encourage every agency and process calculated to promote that end. The low- or even the high-temperature carbonization of coal, complete gasification, improvements in the water-gas reaction, the increased demand from industrial heating and other developments furnish an encouraging outlook whose reduction to everyday industrial and living condition we shall hope

to see consummated in the early years of the new fuel century now before us.

The problem of air sanitation is as complex as it is vital in importance. It cannot be claimed that more than a faltering step has been made in the direction of its solution. It will require from now on more of chemical than mechanical skill.

CHAPTER XIV

THE FUNDAMENTAL PROPERTIES OF COAL RELATED TO CARBONIZATION

Action of Solvents on Coal.—The study of coal carbonization has been greatly promoted by the fundamental research on the constitution of coals which has characterized such studies in recent years.

The first of such work was inaugurated by Professor Vivian Lewes¹ of England and involved the use of such solvents as pyridine, phenol, xylene, etc., for resolving the coal into its coking and non-coking constituents. By this means the coal

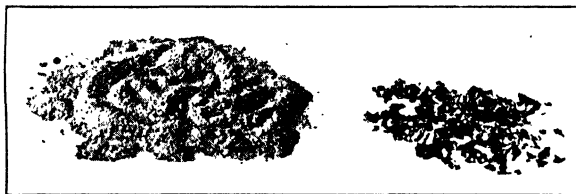

FIG. 46.—Lignitic and bituminic portions of coal separated by phenol extraction.

may be separated into two parts having distinctly different properties. The cell skeletons of the bright bands and the general attritus of the dull bands supply the larger portion seen at the left in Fig. 46. This is the insoluble part more or less closely related to lignin and designated as the lignitic residue. The soluble portion (Fig. 46 at right) is related to the resins and bitumens, and is undoubtedly a mixture of the two with the predominating material more nearly resembling the bitumens; hence, the designation of "bituminic substance."

Subdivisions of these very complex compounds of the lignitic and bituminic type have been made, but it is not our immediate purpose to follow these limits of separation into pure and identi-

¹ LEWES, VIVIAN B., Coal carbonization: *Progressive Age*, vcl. 29, p. 1030, 1911.

fiable compounds. This would be an almost endless task and when completed would give us none of the direct information needed which we seek, that is, a comprehension of the mechanism of carbonization. Moreover, it is not the properties of the separate compounds which will help us in this study, since they do not act as independent entities, but rather we want to know about their interactional and combined behavior, for it is these conditions with which we have to deal.

Turning our attention therefore to the two main groups, the lignitic and the bituminic material, we find that they occur in the type of coals here studied in approximately the ratio of five or six of lignitic to one of bituminic substance. Their distribution is fairly even throughout the coal, although the bright band has more of a soluble substance resembling the bitumens, while the dull portion which contains more of the spore residues seems to have an accentuation of a soluble material more nearly related to the resins.

Effect of Oxygen on Lignitic and Bituminic Portions.—As a result of the studies on oxidation at various temperatures, as shown in Figs. 23 to 26, it is obvious from the discharge of H_2O and CO_2 , with an attending increase in weight of the coal, that certain chemical changes take place within the coal substance during the action of the gas. Let us note the effect of oxygen absorption upon the coking property of coal in its normal or unseparated form. This may be shown readily by the ordinary determination of volatile matter wherein a 1-gram sample is subjected to destructive distillation in a small crucible at $900^\circ C$. Such rapid heating has been found to be the optimum condition for producing coke, and a negative result in this test would be definite proof that the coking property had been destroyed. In Fig. 47 are shown, in parallel, the results of such a test; the one at the left being a coherent coke button from the fresh coal, the other from the oxidized coal, a loose powder with no coherence.

The question now naturally arises as to whether this oxidation effect is produced in one or both of the type substances equally. To test this point a separation of an Illinois coal by use of xylene under a pressure of 300 lb. per square inch at $240^\circ C$. was made, and the lignitic and bituminic portions subjected to the coking

test.¹ The fresh lignitic residue showed no coke structure whatever (Fig. 48a), while the bituminic extract swelled into a light, flaky and easily crushed mass (Fig. 48b). When the two materials were recombined in the proportions in which they existed in the original coal, the coking property was regained. If, now, the residue was oxidized at 110°C. in a current of air for 1 week and then recombined with fresh extract, the coking property

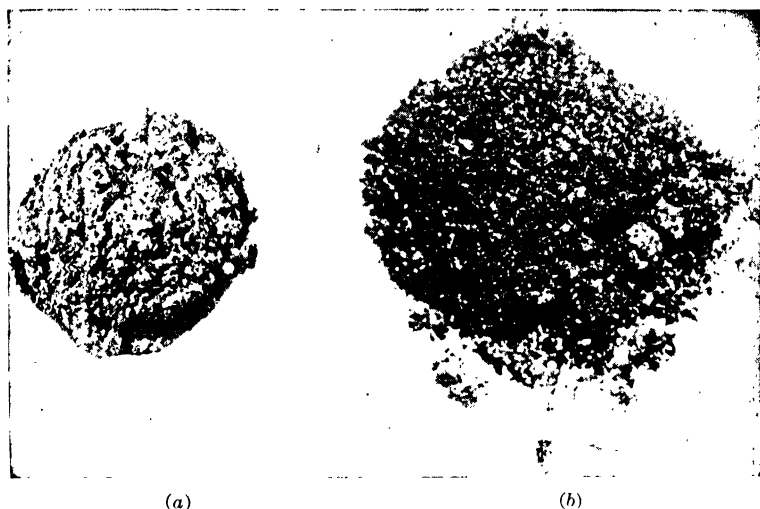

FIG. 47.—Relation of coking property to state of oxidation of coal. (a) Fresh coal, good coke. (b) Oxidized coal, no coke.

was again destroyed (Fig. 48c). Finally, the test on recombined fresh residue with oxidized extract produced excellent coke (Fig. 48d). Here then is evidence of an intertype reaction which is of fundamental importance in coal carbonization. The coking property which is seen to reside in the bituminic fraction is completely destroyed as a result of some interaction with the oxidized lignitic material.

In order to secure further information relating to these chemical reactions let us apply the process of fractional distillation to both the fresh and oxidized fractions, using distillation temperatures

¹ HEALD, R. F., A study of the reactions occurring in coal at temperatures below 360°C.: Unpublished Univ. Ill. thesis for M. Sc. degree, 1925.

up to 300°C. at which we may secure a decomposition of the oxygen compounds without appreciably disturbing or liberating the hydrocarbons. The oxidation evidently affects both the volume and the composition of the gas which is evolved. Table

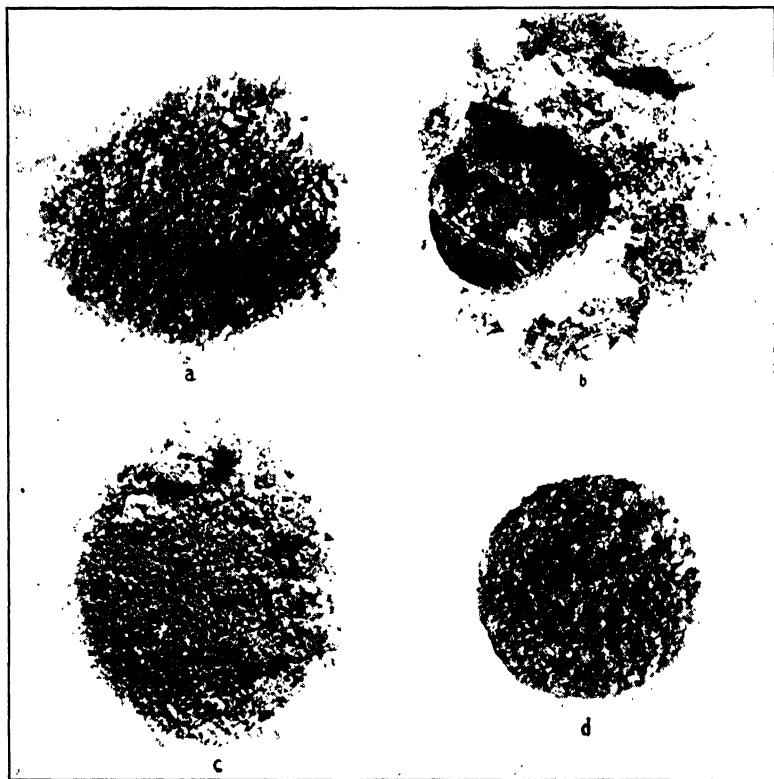

FIG. 48.—Relation of coking property to state of oxidation of lignitic and bituminic material in coal. (a) Fresh lignitic residue—no coke. (b) Fresh bituminic extract—flaky mass. (c) Oxidized lignitic combined with fresh bituminic material—no coke. (d) Fresh lignitic combined with oxidized bituminic material—good coke.

XVI gives values obtained from the oxidized as compared with the fresh or unoxidized components. The great increase in the oxides of carbon owing to the oxidation of the lignitic residue should be especially noted. In striking comparison, the gases from the oxidized bituminic extract differ only slightly from

those from the fresh extract. There is a slight increase in the oxides of carbon in the case cited, but in other coals there was an actual decrease in these constituents after oxidation.

By extending the distillation to 350° and plotting curves for CO₂ against temperature, which closely follow those for the total gases evolved, we find that the oxidized lignitic material follows a method of decomposition, both in the matter of volume and in the type of constituents evolved, which is in marked contrast to the parallel conditions for the fresh or unoxidized material

TABLE XVI.—COMPOSITION OF GASES FROM THE DESTRUCTIVE DISTILLATION OF FRESH AND OXIDIZED CONSTITUENTS OF COAL (VERMILION COUNTY, ILL.) TEMPERATURE, 300°C.

Gas	Lignitic residue, cubic centimeters per 100 grams		Bituminic extract, cubic centimeters per 100 grams	
	Fresh	Oxidized	Fresh	Oxidized
CO ₂	48.0	1,277.1	742.5	917.5
Illuminants.....	0.3	0.9	19.5	21.0
O ₂	3.1	6.8		
CO.....	11.4	175.0	41.0	99.0
H ₂	4.5	3.7	33.0	38.0
CH ₄	None	5.3	49.0	27.5
C ₂ H ₆	None	0.9	45.5	15.5
Total.....	67.3*	1,469.7*	930.5†	1,118.5†

* Not including N₂.
 † Not including N₂ and O₂.

(Fig. 49). In the fresh material no appreciable decomposition has occurred below 250°C., while from the oxidized sample a copious evolution of the gas begins at about 150°C. It is especially notable that reactions of this type occur mainly below 350°C. for all coals. Comparing the curves for the soluble and insoluble portions, it is evident that the lignitic residue is more affected by the oxidation than the bituminic.

These fractional-decomposition studies therefore indicate the lively reactivity of the lignitic matter and the relatively small change in the bituminic matter as a result of oxidation. The

coking property of the bituminic matter, however, is evidently very susceptible to the reactions set up by the lignitic residue. These reactions affect the bitumens below the softening temperature which exists in the range from about 250 to 350°C. Since, at these temperatures, there is a marked evolution of carbon

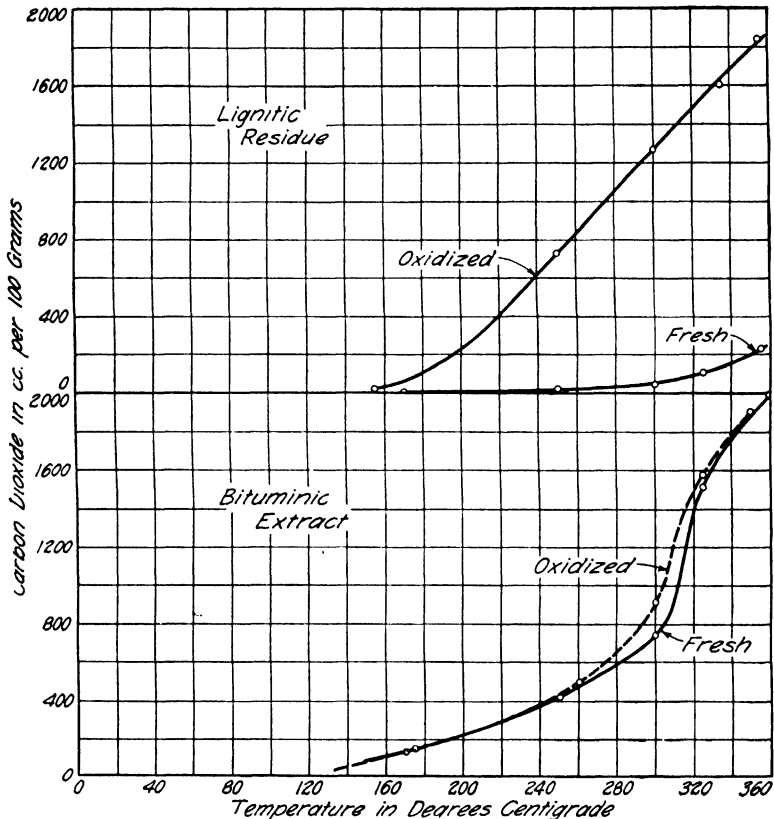

FIG. 49.—Effect of oxidation on carbon dioxide evolution from coal constituents during distillation.

dioxide from both the oxidized cellulosic and bituminic substances, it follows that, if we are to have a coherent or real coke residue as a final product, there must be an avoidance of deterioration by oxygen, so far as is possible, before the softening or carbonization stage is reached.

From the preceding studies on oxygen absorption and primary decomposition it is evident that there exists a conditioning stage involving the factors of atmosphere, temperature and time, which must be rigorously observed before passing to the higher range of actual carbonization that takes place at and above the softening temperature. The significance of this softening point must be fully realized before proceeding further.

Softening Temperature of Coal.—It can be readily understood that any substance which passes from a granular to a coherent mass as a result of the action of heat must have passed through

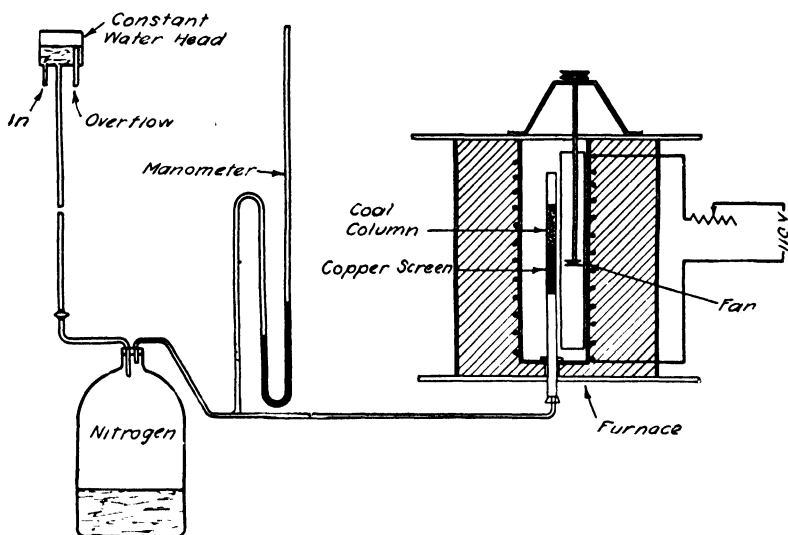

FIG. 50.—Melting and solidification apparatus for experiments on coal.¹

a molten or at least a pasty stage. This is especially true of organic material, with emphasis on the fact that organic substances, if they have a melting point, acquire that condition before any substantial decomposition has taken place. Obviously, therefore, in the case of coals, if any portion of the coal substance has this property of melting or assuming the pasty condition, it must be augmented or at least conserved in every possible way. In applying any of these methods of conservation we must make use of those basic factors which have to do with

¹ LAYNG and HATHORNE, *Ind. Eng. Chem.*, vol. 17, p. 165, 1925.

the protection of that all-important constituent, the bituminic material. Hence the necessity of knowing the temperature for any coal at which liquefaction or pastiness occurs.

The softening and solidifying phenomena will be better understood after a brief reference to an apparatus for indicating the temperature at which melting occurs, and something of the

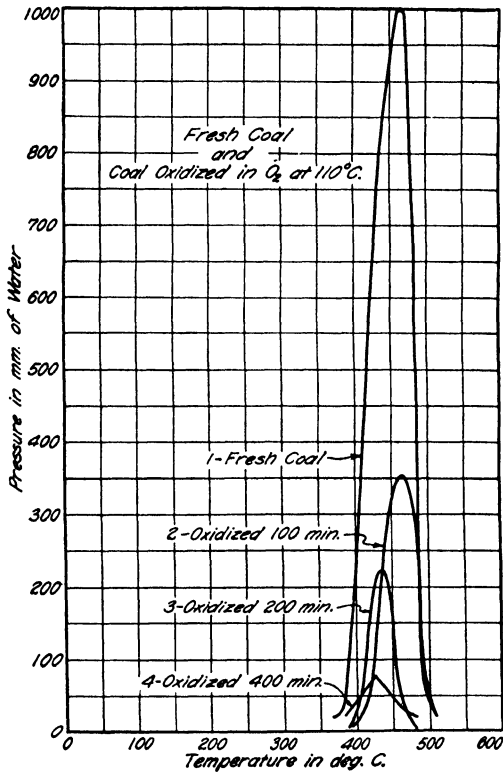

FIG. 51.—Effect of oxidation on softening and solidifying properties of an Illinois coal.

extent of time over which the pasty state exists before passing over to the solid phase again. In the apparatus, shown in Fig. 50, a slow current of nitrogen or other gas is driven past a manometer and through a 10-gram sample of coal held in a tube open at the top and heated by an electric resistance furnace under close temperature control. The softening effect in the coal

creates a back pressure on the manometer. The pressure readings, plotted in millimeters against temperatures, give significant curves relating to the softening and solidifying properties. The results obtained on a single Illinois coal (Fig. 51, Curve 1), will illustrate the character of the curve and the information which it conveys.

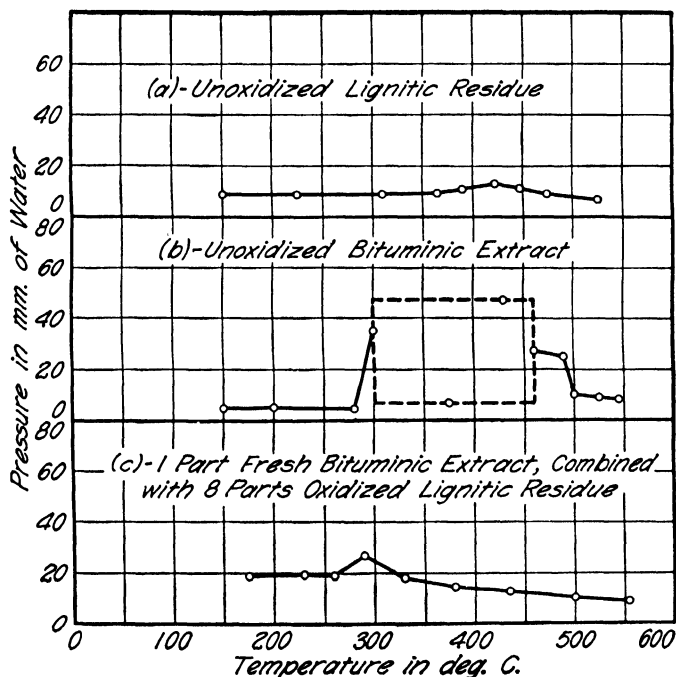

FIG. 52.—Effect of oxidation on softening and solidifying properties of coal constituents.

When the softening-point determination is made on different coals, the characteristic differences in the shape of the curves suggest a feature that is of great importance in diagnosing the behavior of any single coal and also leads to a better understanding of the reason why a better coke structure may sometimes be secured by blending coals having widely different curves. This suggests a further method for determining what reactions may have the effect of lowering or destroying the property of softening or melting. For example, in Fig. 51, the characteristic curves

show that the coal is changed from a substance having a definite melting point to one without any melting point, when it is subjected to a temperature of 110°C. in oxygen for 100, 200 and 400 min., respectively, in the last interval, all of its melting or coking property being destroyed.

If the same method is applied to the two coal fractions, the results, shown in Fig. 52, indicate that:

- a. The lignitic residue is altogether without softening property.
- b. The bituminic substance assumes a completely liquid condition, the maximum and minimum pressure effects being substantially what we would expect from a liquid or viscous mass.
- c. By saturating the insoluble residue with oxygen and combining in normal proportions with the fresh bituminic extract, the molten condition is destroyed.

These results again prove that the bituminic material is the key to the entire problem of coke formation by reason of its melting or softening property and at the same time, especially with coals of the mid-continental type, is exceedingly sensitive to the treatment accorded it.

Thus accentuating certain reactions under known conditions, we have established the fact that the melting or coking property of the bituminic substance may be readily destroyed by liberating at the coking temperature either oxygen or the oxides of carbon.

Summary.—The results of reaction studies on coals and their subdivisions may be summarized as follows:

1. Coal is a very active absorbent for oxygen. This absorption begins even at the face of the vein before the coal is broken out from the seam, and proceeds with great acceleration as the coal mass is broken into finer particles by blasting, screening and transportation.
2. The most active portion, chemically, is the lignitic constituent of the coal.
3. The bituminic substance possesses the softening or melting property and is the fundamental substance responsible for producing a coherent coke structure as a result of heat continued through the decomposing stage.
4. The bituminic substance softens or melts at temperatures usually between 300 and 400°C. Below this range it is very

susceptible to chemical changes which tend to cause a reversion to a composition more nearly related to the lignitic substance, especially in regard to its melting property which is greatly decreased or destroyed altogether. Naturally, the time element is a factor in producing this change, a long exposure to these conditions producing a more complete effect while the reversion is minimized if the preliminary stage of high susceptibility is shortened with respect to time.

5. As a corollary to item 4 and as a result of the known properties of organic compounds already referred to, the time factor for completing the carbonization process above the softening temperature must be taken into account. A quick application of heat and a short period of carbonization contribute to the density and strength of the solid residue. This effect of time has been well established in ordinary volatile-matter determinations where the results, both as to physical properties of the button produced and the chemical nature of the volatile matter, are directly modified by the speed with which the carbonization has been effected.

A Carbonization Theory.—We may now formulate a procedure for meeting the conditions thus indicated for conserving the bituminic material, and for correcting any alterations already present in the cellulosic substance that are detrimental to the coking property, and which, if not disposed of, will weaken the melting and bonding property of the bituminic material. The following method seems to be indicated:

1. Any accumulation of oxygen or oxygen compounds of carbon, resulting from the absorption or chemical addition of that element due to exposure to the air, must be removed by moderate heat.

2. The discharge and ready removal of any product of decomposition, particularly oxygen, carbon monoxide and carbon dioxide evolved during the rise in temperature of the bituminic material before it reaches the plastic stage, must likewise be accomplished. This implies that not only should there be a ready discharge or removal of such gases from the zone of activity, but also the time for contact with such reacting gases must be reduced to a minimum, thereby diminishing the opportunity for deleterious chemical interactions.

3. The time is greatly conserved by separately evaporating the free moisture which often amounts to from 10 to 15 per cent of the weight of the coal below 100°C., so that the raising of the mass through the remaining range up to 300°C. may be accelerated. A condition is thus secured whereby the additional 100°C. above 300°C., required to produce the plastic condition, can be quickly distributed throughout the mass.

4. More especially is it important to reduce to a minimum the time required for completing the reactions involved in the carbonization period which occurs immediately following the initial pasty stage. This is most readily accomplished by such preliminary or conditioning treatment as shall raise the sensible heat to a point as high as possible and still be below the temperatures at which softening occurs; a rapid decomposition may be brought about when such material is subjected to the desired temperature for effecting the actual process of carbonization.

CHAPTER XV

CARBONIZATION METHODS

From the preceding discussion it is evident that carbonization methods differ widely, a fact which makes difficult any systematic study of the general topic. It must be emphasized at the outset that coal deposits vary greatly in accessibility, physical properties and chemical composition, and the economic factors involved present for the most part separate problems which can only be solved by recognition of these primary factors.

In reviewing the various methods proposed for the processing of coal, it would be helpful if some system of classification could be agreed upon. However the classification of carbonization processes is not a simple matter. Not only do the methods of operation proceed along many different lines, but the types of material differ widely and the specific ends to be attained are very divergent. Nor is the matter simplified by reason of the number of methods proposed. Gentry¹ has investigated over 175 different processes and Brownlie² would add at least 40 more to that list. Moreover, no method is adapted to all types of coal or to meet the optimum yield of all by-products or to serve equally well all the diverse purposes required.

Classification According to Temperature.—For the immediate purpose of this discussion it will be most convenient to assume a classification along the line of temperatures employed as follows:

Methods of Coal Carbonization	{	High temperature 1800 to 2000°F.
		Low temperature 700 to 1100°F.
		Mid-temperature 1200 to 1500°F.

High-temperature Carbonization, 1800 to 2000°F.—This method has been developed to a high state of efficiency. It represents a divergence from the early practice where metal

¹ GENTRY, F. M., "The Technology of Low Temperature Carbonization": William & Wilkins Co., Baltimore, 1928.

² Private communication.

retorts were employed and the allowable temperatures were necessarily low. With the adoption of refractory retorts and the use of the by-product oven for making metallurgical coke, a radical change in temperatures has come about. The gas maker demands the maximum yield of gas, and the coke maker demands the strength and hardness for his coke that accompanies the high gas yield. It is natural, therefore, that the metallurgical by-product oven should come into the gas-making field even to the extent that in some instances the coke should become the by-product, and gas the main output.

In this field the research activities have not been wholly absent but they have been mainly of a mechanical and physical type rather than of a fundamental sort involving chemical constitution and those chemical changes which characterize the carbonization process. Be it said however in passing that the high-temperature operators have become impressed with the potential magnitude of the manufactured-gas field. They have made some most commendable advances in an effort to meet the demand for smaller units and less expensive installations and are now thinking in terms of hundreds of tons instead of thousands of tons per day.

Low-temperature Carbonization, 700 to 1100°F.—It will be conceded at once that by far the greatest activity has existed in the low-temperature field. The reasons have not been obvious. About the year 1904 carbonization experiments were being conducted in England, using temperatures of approximately 900°F. The coke produced was free-burning, the tars were abundant and more of the type of oils than of tars, and the gas, though relatively of small volume, was of high grade. Practically all of these features appealed strongly to the needs of the English people. This first exploitation of the idea with its mechanism of operation has been followed by a bewildering number of modifications as to method of operation as well as to the appliances for carrying them out. About the same time that the English experiments were initiated, or a little earlier, similar studies were begun in America, though from a somewhat different standpoint, having largely in mind the production of a smokeless fuel from low-grade coals and thus competing for a market in the anthracite field.

The number of low-temperature processes projected is great and their features cover a wide and varying range of attractiveness. Even a brief discussion of a selected number of those which might be called type processes or which may have attained to some degree of commercial development cannot be undertaken here. It will be quite sufficient for our purpose to list a few in Table XVII, in something of a classified form, which will suggest in a general way the principles of operation involved.

TABLE XVII.—CLASSIFICATION OF LOW-TEMPERATURE PROCESSES

Processing of coal using low temperatures—from 700 to 1100°F.	Continuous	Externally heated	K.S.G.— Carbocite { Rotating steel drums, producing char and pellets, little gas, much oil
			Plassman { High pressure during coking. or C.T.G. { Hard, dense product
			Johns { Heated hearth only. See Knowles process under intermittent type
			Hayes { Rotating drum. Special alloy. Briquetting the char
			Carbocoal. Three stage Pinet—Debout { Flow feature utilized for —Trent { continuous carbonization
	Intermittent	Internally heated	Lewes, White { Pulverized and dropped through externally heated chamber "Bubble coke"
			McEwen-Runge. Finely pulverized and dropped
			Babcock { Water gas, 80 B.t.u., all burnt with the char under boilers
			Bussey { Similar to above but not operating in conjunction with power plant
			Maclaurin. Similar to Bussey process Carson. Complete gasification
Intermittent	Externally heated	Illingsworth. Thin layers hot metal core	
		Coalite or Parker. Thin layers	
		Knowles { Sole flue oven, heated from below only	
Intermittent	Externally heated	Stevens { Carbon resistor heated by electric current. Off-peak load	

Mid-temperature Carbonization, 1200 to 1500°F.—Between the high-temperature coking range of 1900°F. and the low-

temperature range of 900°F. is a zone of carbonization near 1400°F. to which brief reference should be made. Only one project makes specific use of this temperature and that is the one developed at the University of Illinois. The fundamental objective in the working out of that method was to secure a yield of gas that would be attractive to the gas maker and at the same time produce a coke, especially from Illinois coals, that would be readily salable in the domestic market or directly available for complete gasification or for power purposes. A

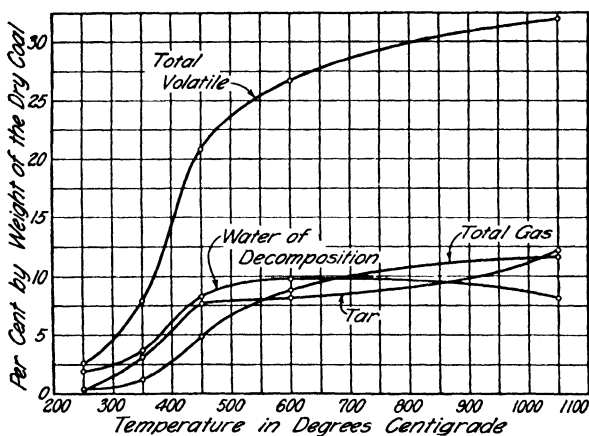

FIG. 53.—Effect of temperature on coal constituents in the carbonization of Illinois coals.

detailed description will not be repeated here, except to note that by maintaining the flue temperatures of a standard oven at the usual range, say, 2000 to 2200°F., a heat cycle may be maintained within the oven by charging with fresh coal which has been quickly preheated to 500 or 600°F., in an auxiliary unit; the mass will have attained a temperature of 1400°F. at the end of the carbonization period of about 5 hr., after which the coke is dropped or pushed and a fresh charge at 500°F. added to repeat the cycle.¹ The fundamental factors involved in the various stages of conditioning, softening and carbonization, previously discussed, indicate quite clearly the method for their application.

¹ PARR, S. W., Low temperature carbonization of coal: *Proc. 2d Internat. Conf. on Bituminous Coal*, Carnegie Inst. Tech., Pittsburgh, 1928.

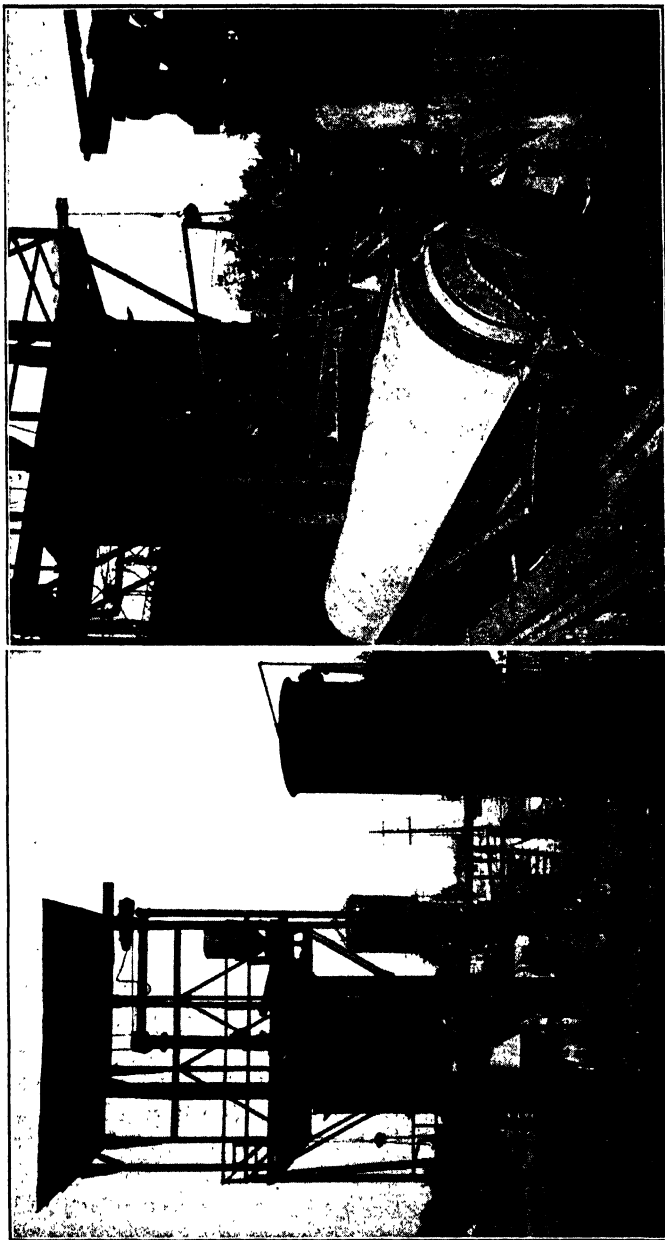

Fig. 54.—Views of experimental plant of Urbana Coke Company, utilizing the Parr process for coking Illinois coals, showing preheater at the right.

The first temperature zone in the heating of coal extends to somewhat above 100°C.; in this zone the moisture is eliminated. The second zone extends up to about 300°C.; in this zone some of the oxygen compounds are given off, consisting of H₂O and CO₂. These are products of decomposition that occurs below the softening temperature of the coal. The coal is heated through these first two zones in the preheater.

The graph in Fig. 53¹ shows the elimination of volatile matter by progressive heating of an Illinois high-oxygen coal, but the principles involved would apply equally well to a coal of low oxygen content or coking type. As the coal is heated up to 250 to 350°C., reactions occur which result in the rearrangement of the molecular structure in such a manner as to cause the breaking down of the hydroxyl and carboxyl constituents with the formation of water and carbon dioxide. The range of temperature required to produce these reactions is below the softening point and there is little decomposition of other constituents to cause a loss of hydrocarbon compounds; hence, the reactions at this stage are of value in discharging inert material, in lowering the oxygen content, and in benefiting the reactions immediately following at temperatures above the softening point. These reactions are directly concerned in the formation of coke.

As a result of the low-temperature decomposition of the hydroxyl and carboxyl compounds, the volatile matter at 250°C. consists almost entirely of water and carbon dioxide. At 350°C. nearly one-half of the volatile matter is water of decomposition and almost half of the gas fraction is carbon dioxide. Above 350°C. general decomposition takes place and the amounts of all forms of distillation products increase but the combustible products predominate. Attention is called to the fact that the essential reactions are complete at a temperature of 750°C., as shown by the maximum quantities of tar and water of decomposition. Above that temperature, the volatile matter consists mainly of "lean gas."

Views of the experimental coking plant in which these principles were first utilized on a large scale are shown in Fig. 54.

¹The curves were plotted from the data of Porter and Taylor, U. S. Bur. Mines, *Tech. Paper* 140.

CHAPTER XVI

PROCESSED FUELS—COKE AND BRIQUETS

As a result of the development of carbonization methods, various types of artificial fuel have come into use. Such fuels, in order to meet with popular acceptance, must have specific properties which commend themselves to the users, such as efficiency in combustion, freedom from smoke, absence of dust, dirt, etc. Any method of processing fuel, therefore, should leave the resulting solid material in a coherent mass, strong enough to withstand handling and shipment, and also having the property of retaining its form throughout the period of combustion thus permitting a ready transmission of air through the fuel bed.

Coke.—These conditions would seem to be met in the most obvious manner by coke. It can readily be understood therefore why coke is now having such an extension of its use, especially for domestic purposes. Certain prejudices, however, have had to be overcome in its adoption as fuel. These mainly relate to the difficulty of holding the fire at the proper rate to meet the wide variation in temperature requirements. This has necessitated a study on the coke-maker's part of the best form in which to supply this material, with the result that coke in nut form is now the form usually supplied for use in domestic appliances.

The Reactivity of Coke.—Another factor which has required an extended investigation is that of the reactivity of different cokes. This term does not have a definite meaning, as with one group of investigators it is measured by the decomposing action on carbon dioxide at high temperatures, while with another it is a question of catalytic, or compositional effects, including combustion. It is the latter which we shall discuss in some detail here because of its bearing on the use of coke in household furnaces.

The property of reactivity varies widely with the manner in which the coke is made. This is shown by the following experi-

ments. Carbon begins to react with oxygen at a definite temperature. With an increase of temperature the rate of reaction is modified, but not the character of the reaction. When the temperature at which activity begins is reached, there is a sudden increase of temperature which automatically increases the rate, and the reaction proceeds autogenously. It is evident that some temperature near the point where the reaction begins may very properly be taken as a starting point which may be used for an index of the relative reactivities of various forms of free or elemental carbon. In the case of coal this point has been called

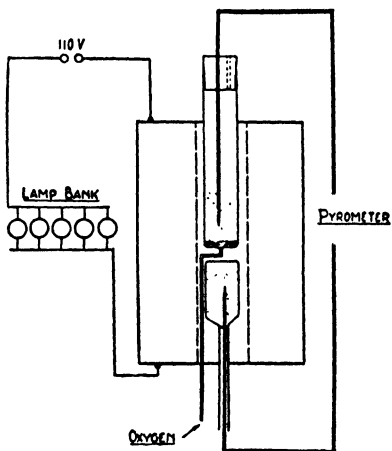
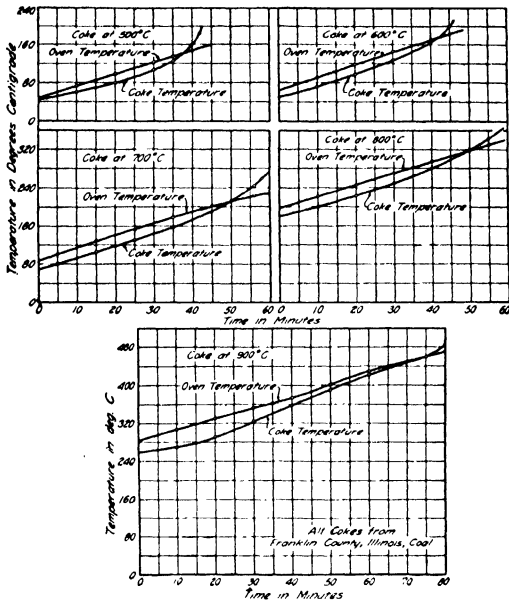

FIG. 55.—Apparatus for determining the reactivity of coke toward oxygen.

by Wheeler and others the "ignition temperature," which is only another way of designating the relative temperature of reactivity. It follows, therefore, that the methods employed for determining the ignition temperature for coals might also be applied directly to coke.

The apparatus used in this study, therefore, is similar to that already described in determining the critical oxidation temperature of coal. Because of the limitations in the range of mercurial thermometers it is necessary to modify it to the form shown in Fig. 55. Here the two containers are of the same size and shape, and each is filled with the same material to be tested. They are so placed in the furnace as to receive an equal amount of heat and each has a thermocouple at the center of the mass. Oxygen is circulated through one charge while the other remains as a blank for comparison.

In studying the reactivity of numerous types of coke by this method it at once became apparent that the reactivity was a function of the temperature at which the coke had been made. This is well illustrated by the charts in Fig. 56a where the samples have been obtained by carbonizing a certain coal at five different



(a)

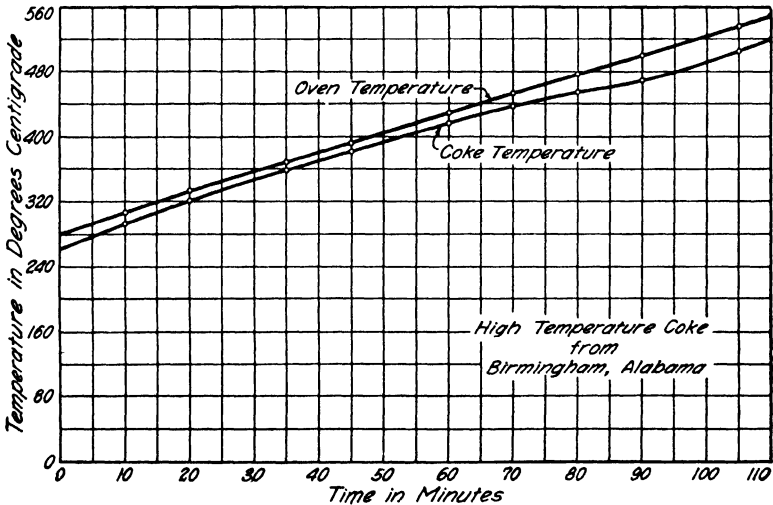

(b)

Fig. 56.—The effect of coking temperature on the reactivity of coke.

temperatures from 500 to 900°C. Because of its definiteness the critical point for denoting the beginning of positive reactivity has been taken at the crossing of the lines representing the temperatures in the two containers. This would seem to be justified since the temperature increase from this point on is rapid. In Fig. 56*b*, showing the results for a high-temperature coke, the lines do not approach each other within the practical working range of the apparatus, from which it is assumed that the reactivity point is above 600°C. For more convenient comparison these values are grouped in Table XVIII.

TABLE XVIII.—EFFECT OF COKING TEMPERATURE ON REACTIVITY

Coking Temperature, °C.	Reactivity Temperature, °C.
500	144
600	178
700	218
800	314
900	456
1,000	Above 600

It follows therefore that for domestic fuel, where ease of ignition and holding of the fire are desired, cokes made in the low- or mid-temperature range are more desirable than those made in the high-temperature range.

Furthermore, this behavior of carbon would seem to upset some of the previous notions concerning coke formation. Graphitization, to a greater or less degree, is sometimes suggested as an explanation for variations in the reactivity of coke made at high temperatures and for varying lengths of time, but that theory could not be applied to coke made at the carbonizing temperatures here illustrated.

Fuel Briquets.—The demand for clean and smokeless fuel for domestic use grows and, indeed, receives added emphasis in spite of the indifferent success of attempts to obtain this objective by means of low-temperature methods of carbonization. One of the most hopeful methods now showing a consistent increase in production is the manufacture of briquetted fuel. The total amount of briquet produced in 1929 was 1,212,415 tons, being twice the tonnage produced 9 years previously, in 1920. The value of this output in 1929 was \$7.85 per ton at the

plant, giving a total of \$9,515,205. Statistics of production are given in the chart, Fig. 57.¹ During the anthracite shortage of 1926, importations of fuel in briquet form amounted to 123,593 tons. Importations continued through 1929, coming mostly from Germany, and amounted to 89,458 tons.

It is of interest to note that of the 48,000,000 tons briquetted annually in Germany 90 per cent is lignite. In America the raw fuel used was for the most part semi-bituminous, bituminous



FIG. 57.—Development of the briquet industry in the United States, 1915–1930.

and sub-bituminous slack, 60 per cent of this type of material making up the briquetted product. Approximately 34 per cent was made from fine sizes of anthracite and the balance from semi-coke, and carbon residues from oil-gas manufacture.

Much could be said in favor of fuel supplied in the briquet form, especially for domestic use. Theoretically it is the nearest approach that can be devised to anthracite in nut sizes. It has all of the virtues of combustion possessed by anthracite. It can be made to conform to some standard type and thus would eliminate to a large extent the present chaotic state in

¹ KIESSELING, O. E., and CORSE, J. M., Fuel briquets in 1929: "Mineral Resources of the United States," 1930, p. 23.

the marketing of domestic fuels. It should lend itself more uniformly to serving that type of mechanism now being introduced as small units for automatically stoking the household furnace and meeting the average household requirements as an offset to the automatic heat now so largely available from the use of oil or gas.

In all the range of special or processed fuels the field of briquetting is probably the most inviting. This is due to certain fundamental economic factors, such as the accumulation of fine material in the process of mining and preparation for the domestic market. In the Illinois field approximately 45 per cent of the output from the mines occurs as slack which must be sold at a loss. Slack costs approximately \$1.25 per ton to produce at the pit mouth and is marketed at an average price which does not exceed \$1.00 per ton. The loss, therefore, must be carried by the screened sizes of lump and nut coal. This represents not only a serious economic waste but imposes a burden upon the user of domestic sizes where the fine material must be rigidly eliminated. The briquetting of the fine material would seem to be the solution to this economic misalignment.

There are certain difficulties not yet recognized or solved industrially, such as the desirability of washing to reduce the high ash content of the finer sizes which characterizes the output from the Illinois field. Another handicap is the inability, thus far, to use or devise a binder from high volatile coals, that shall be smokeless in combustion. The binder must be waterproof, strong enough to withstand abrasion and must retain its shape during combustion. These factors will ultimately be supplied. The proportion of binder, at present used, ranges from 5 to 9 per cent of the raw fuel. Most plants use an asphaltic pitch or other type of binder of a smoke-producing type. Others employ molasses, starch or cellulose waste, or sulfite liquors from the manufacture of paper.

CHAPTER XVII

FUEL GAS

Introduction.—Of all fuels the gaseous type is the most nearly ideal. It is more definitely subject to automatic control than other fuels; it can be burned with high efficiency and with a minimum of attention; it produces the least possible contamination of the air from smoke, sulfur dioxide and other noxious gases.

The gas industry was originally developed as a lighting proposition. With the advent of electricity, however, it began to take second place in that field. Today the industry has found its place in the heating and power requirements of the nation.

The outstanding development of the last 5 years has been the phenomenal increase in utilization of natural gas. The striking progress is shown by the figures for 1929 which show nearly two trillion cubic feet of natural gas produced and delivered to consumers, an increase of 22 per cent over the preceding year. Of this amount about 19 per cent went to the domestic user and the remaining 81 per cent was devoted to industrial purposes. Sales of manufactured gas in 1929 amounted to 524,000,000,000. cu. ft. or only slightly more than one-fourth of the volume of natural gas. Of the types of manufactured gas, the production of water gas, which at one time amounted to nearly 75 per cent of the nation's gas supply, has steadily decreased until now it equals only 40 per cent of the manufactured gas and only 10 per cent of the total gas used. On the other hand, coke-oven gas has increased until it now amounts to nearly 30 per cent of the manufactured gas produced. This development suggests that with the exhaustion of our natural-gas supplies, and the modifications in the standards of requirements for house use now taking place, the production of the future will come, in the main, from installation of the by-product oven type and from generators of the water-gas type, using either coke or raw coal. Problems of manufacture and purification, and standards of quality, cannot be elaborated

TABLE XIX.—TYPICAL PERCENTAGE COMPOSITION OF FUEL GASES
(Compiled from various sources)

Type of gas	CO ₂	O ₂	Illuminants		H ₂	CO	Paraffins		N ₂	Gross B.t.u.	Approximate flame temperature, °F.
			C ₂ H ₄	C ₆ H ₆			CH ₄	C ₂ H ₆			
Natural.....	0.4	87.0	9.6	3.0	1,050	3600
Coal gas											
Horizontal retorts.....	1.5	0.3	2.2	..	52.5	8.6	31.4	...	3.5	575	3650
Vertical retorts.....	2.5	0.3	3.4	..	52.3	10.7	26.9	...	3.9	552	3600
Coke oven											
Koppers.....	2.2	0.7	3.6	..	51.9	6.0	27.1	...	8.5	535	
Water gas											
From bitum. coal.....	5.4	1.1	0.9	..	41.9	34.0	7.5	...	9.2	335	3800
From coke.....	4.0	0.5	45.7	45.8	2.0	...	2.0	322	3800
Carb. water gas.....	3.9	0.9	6.7	2.2	34.6	33.4	10.4	...	7.9	536	3800
Pintch.....	35.0	..	4.5	0.5	60.0	1,500	
Low-temp. carb. below 800°C.....	3.9	0.8	1.5	1.6	47.3	4.3	33.2	4.5	2.9	670	
Produce.....	2.5	...	0.4	..	12.0	27.0	2.5	...	55.6	157	3100
Blast furnace.....	10.0	1.0	3.0	27.5	0.5	...	58.0	102	2800
Refinery.....	25.4	..	0.3	74.3
H ₂	326	3900
CO.....	323	3850
C ₂ H ₄	1,639	3880
C ₂ H ₆	1,487	4160

in this connection. A brief description of the various types of gases available follows. Methods of analysis are described in Chapter XXX. Table XIX is a summary showing the typical composition of several common types of gases.

Producer Gas.—The virtues of gaseous fuels were clearly realized by Sir William Siemens, a pioneer in the development of producer gas. He wrote in 1881:

I am bold enough to go so far as to say that raw coal should not be used as a fuel for any purpose whatsoever, and that the first step toward the judicious and economic production of heat is the gas retort or gas producer, in which coal is converted either entirely into gas or into gas and coke.

Siemens utilized the properties of gaseous fuels when he devised the regenerative furnace bearing his name. In this device, which is used for the production of open-hearth steel, the hot products of combustion are led from the furnace through two checker-work tunnels of brick, which are quickly heated by the flue gases. When these regenerators become hot they are connected with the fuel- and air-supply, respectively, and the chambers through which the fuel and air had passed previously are heated again by the hot flue gases. The process of preheating fuel as well as air with the regenerators not only recovers much heat but also produces the highest possible flame temperature. This is very important since producer gas has a low calorific value and flame temperature compared to the richer gases used for domestic purpose. Nevertheless, producer gas when properly used is very satisfactory as a fuel and is the cheapest artificial gas per heat unit. It has ideal properties for certain uses, such as reverberatory furnaces and soaking pits. It burns with a "soft" long flame, which facilitates even distribution of heat. It is also used, as are the gases from blast furnaces, for the production of power in specially designed gas engines in steel mills.

Producer gas may be made by blowing controlled amounts of air through a deep hot bed of coal or coke. Such a gas is called "air-blown producer gas" or "Siemens gas." The combustion is incomplete and the resultant gas consists largely of carbon monoxide. Because the oxygen in the air blast is accompanied

by much nitrogen, this fuel gas contains at best 35 per cent carbon monoxide and 65 per cent nitrogen. The calorific value is about 110 B.t.u. per cubic foot. This type of gas is not often used in America but is used to some extent in Europe.

Instead of employing a blast of air alone, air and steam are generally used together in making producer gas. The advantages of using steam in the blast are several. One is the cooling of the reaction zone, due to absorption of heat in the reaction which forms carbon monoxide and hydrogen from water and incandescent carbon. This cooling action preserves the refractory lining of the converter. Slagging of the ash is also reduced to a minimum and hence the operation of the producer is much smoother. Another advantage of the addition of steam to the blast is the added calorific value of the water gas. Producer gas made with steam consequently has a heat value of about 130 B.t.u. per cubic foot.

Water Gas.—Water gas, or “blue water gas,” is made by blowing air through a deep fuel bed somewhat like that used for producer gas and wasting the flue gas to the air. The flue is then closed, the generator connected to the gas collecting system, and steam alone is blown over the hot carbon. The carbon monoxide and hydrogen thus formed give a gas which has a rather low calorific value of 335 B.t.u. but a relatively high flame temperature. Gases of the types just described are almost never used as such for domestic purposes. City gas generally consists of carbureted water gas or coal gas.

Carbureted Water Gas.—This fuel is largely used in the United States today since it is made with relatively cheap compact machinery which can be started and stopped easily in order to meet the unusual demands. For this reason, nearly all coal-gas plants have auxiliary water-gas machines to increase their flexibility in meeting daily and seasonal fluctuations in load. Without them, the gas companies would have to employ greater gas-storage equipment or maintain temporarily idle retorts, both of which measures are expensive.

Carbureted water gas, which may be regarded as a mixture of blue water gas and a richer oil gas, was evolved in order to meet the standards imposed by custom. Many cities and states require that city gas shall have a certain illuminating power and

a calorific value of from 500 to 600 B.t.u. per cubic foot, because the first coal gas possessed these properties. It would be more economical at the present time to produce more gas of lower calorific value than to make the smaller volume of richer gas. This relationship is utilized in England where gas is sold by the *therm* (100,000 B.t.u.) rather than by the 1,000 cu. ft. The American public is gradually realizing that candlepower and expense go together, and standards of calorific value undoubtedly will be lowered in the interests of economy. The State of Colorado has allowed its gas companies to sell gas of lower heat content than before, realizing that each B.t.u. put into a cubic foot of gas over and above 300 B.t.u. must be accomplished at a much higher cost per B.t.u. Water gas should be carbureted to reduce the danger of carbon monoxide poisoning from leakage, but further carburetion to improve candlepower requirements is expensive.

Coal Gas and Coke-oven Gas.—Coal gas, formed by the destructive distillation of coal, was first introduced by William Murdoch in England, who used it to light a factory building in 1802. It is interesting to note that in 1808 The Royal Society awarded him the medal founded by Count Rumford. The use of gas spread so rapidly that in 1819 even far-away Baltimore had a gas company, and by 1830 there were two hundred gas “undertakings” incorporated in Great Britain.

The original purpose in the manufacture of gas was to provide light, and therefore the initial standards were stated mainly in terms of candlepower. With the advent of the production of light by electricity, about 1870, the gas-making industry seemed doomed. However, the value of gas as a heating medium began to be developed and this change has given new life and a phenomenal development to the industry. The demand has increased to such an extent that gas from coke ovens, once considered a by-product, is now often regarded as the product of prime interest. The use of gas for industrial processes and space heating has brought about a marked increase in the total annual output of manufactured gas, which has risen in 10 years from 300,000,000,000 cu. ft. in 1920 to about 530,000,000,000 cu. ft. in 1930, despite the inroads of natural gas into the market. Gas retorts work best continuously and also represent a large

investment in land and equipment, which must be kept in operation to produce good returns on the investment. For this reason the load from industrial users is a welcome one since it tends to smooth out the "peaks" caused by domestic use.

Coal gas is made by heating bituminous coal out of contact with air. Several types of retorts are used. In the past, the coke and tar produced along with coal gas were of little value and horizontal retorts were commonly used. These give a maximum yield of gas, a very heavy, highly cracked tar, and "gas-house coke" of weak and friable structure. The later trend has been to produce "by-products" of greater value, resulting in the adoption of inclined and vertical retorts and, in the larger installations, by-product coke-oven plants.

Complete Gasification.—A development which may be realized more fully in the future is the complete gasification of coal for the preparation of city gas. The process of complete gasification is not a new one, for the producer-gas process falls in such a category. In order to make a richer gas many processes have been tried, the common principle being that of carbonizing coal at a low temperature and mixing the coal gas with the water gas made from the resulting coke. Some of the heat used in the carbonization is recovered which would otherwise be wasted. Because of this economy and marked saving in labor costs, the process is especially suitable for small installations and for localities which have but a poor quality of coal. The cost of transporting "gas coal" from great distances is a major expense in gas manufacture.

Still another process of future value is that of using oxygenated air in gasifying coal. It is evident that the "blow" gases now wasted to the air because of their large nitrogen content could be included with the "make" gases, with a consequent simplification of operation and economy of heat. The development of this process awaits the production of cheap oxygen.

Natural Gas.—Natural gas was known and utilized before the practical supplies of oil became available, but its value has only recently been realized as a source of fuel supply. Indeed, in the early development of the oil industry, a well which yielded gas only was considered a misfortune and many such wells were ignited and allowed to burn out. At the present time, practically

all gas supplies of this sort are carefully conserved and led into pipe lines for distribution over great distances. Available capital and a rapidly improving technology have increased the practical length of a pipe line from about 100 miles to more than 1,000 miles, as exemplified by some of the lines starting from the Texas Panhandle gas fields. It is estimated that over 10,000 miles of gas lines have been built and that in the last 30 years over \$400,000,000 have been spent in delivering natural gas to the consumer.

The potential heat units in the form of natural gas exceed the total heat value produced in the form of oil. The output of energy from natural gas burned in the United States is estimated as equivalent to 527,000,000,000 kw.-hr. in 1929, which is nearly six times the total production of electricity for the same period.

Refinery Gas.—Closely related to natural gas is the so-called refinery gas, a by-product of the modern methods of cracking petroleum oil for increasing the production of gasoline. This gas is available in considerable quantities at the large refineries whence it is piped for augmenting city gas supplies. For such purposes it must be diluted with a leaner gas, since the undiluted material produced at the refinery has a calorific value of about 1,500 B.t.u. per cubic foot. This is due to an appreciable content of ethylene and other unsaturated compounds. Some of the richer refinery gases are compressed and sold in tanks for use where city gas is not available. Butane, recovered from natural gas, is also shipped in tank-car lots for use in enriching a leaner gas. It is not as volatile as the refinery gases which consist largely of propane and propylene, and hence it must be volatilized by steam heat. A superior sort of "gasoline gas," formed by mixing butane vapor with air, is now being used to advantage in small communities which otherwise could not have the convenience of gas as a fuel. The disadvantage of these fuels is the difficulty of designing and operating a burner which can inject the large amounts of air they require. Butane requires 31 volumes of air per 1 volume of gas for complete combustion; natural gas about 10; and manufactured gas, 5.

In many cases it is desirable to use a mixed gas made from natural or refinery gas and artificial gas. This entails difficulty, however, because of the differences in specific gravity and burning

characteristics of the components. Fluctuating ratios will necessarily cause difficulty at the burners. To overcome this trouble natural and refinery gases are in some cases "reformed" before being mixed with the artificial gas. Reforming is essentially a cracking of the heavier gases to give a mixture more nearly approximating artificial gas in specific gravity and B.t.u. value.

CHAPTER XVIII

WOOD

Wood as a fuel may have war-time interest only; it may be a matter of regional concern or it may be of significance to special industries accumulating wood waste to a point where it must be disposed of.

Calorific Value and Moisture Content.—There are few reliable data on the heat values of wood. Those obtained by Count Rumford over a century ago are frequently referred to.¹ These are little better than approximations. His sample was burned in a current of air and the products of combustion were conducted through a copper coil surrounded by a known weight of water. The chief errors were doubtless the uncertainty of the completeness of combustion and the vague ideas concerning the amount and nature of the moisture present in wood.

Groves and Thorp in their "Chemical Technology"² tabulate the heat values derived by Berthier, Winkler, and Schödler and Peterson. These refer to partially dry, well-seasoned wood, but the real content of moisture is uncertain. Worse than this, however, is the fact that all of these values were determined by calculation from the weight of a lead button reduced from litharge. The equivalent of oxygen taking part in the reaction is used as a measure of the amount of heat, according to the so-called Welter law, which held that a fixed ratio existed between oxygen consumed and heat produced, no matter what combinations were involved. The results obtained do not have the value of a good guess and would need to be increased by about 50 per cent to come even approximately near the true values. Berthier's results were published in 1835, but they do not have as much merit as Rumford's values obtained some twenty years previous, the errors being about twice as great.

¹ *Nicholson's Jour.*, vol. 32, p. 105, 1812; vol. 35, p. 95, 1813.

² Vol. I, p. 360.

In other works of reference, such as Poole's "Calorimetry" (1903), Brame's text on "Fuels" (1914), etc., the values quoted are those of Gottlieb.¹ These values are more recent and have the advantage that they were calculated to the oven-dry basis. He used a calorimeter with oxygen as the medium of combustion, but it was of the constant-pressure type, which seems not to have been capable of as great refinement in results as should characterize the values which are to be used continuously as a standard of reference.

It is evident from this brief survey that the determination of the free moisture present is in as much need of review as the calorific value. Indeed, the latter factor is of little worth without the former. Even greater ambiguity is found in the use of terms than is found in the case of coal. Dry wood is understood to mean well-seasoned wood and there seems to be a reluctance to recognize a sharp line of demarcation between the free moisture and the very large amount of hydrogen and oxygen chemically combined in the H₂O ratio of cellulose (C₆H₁₀O₅)_x.

In a series of experiments at the University of Illinois² using American woods, two objects were in view: (a) to determine the practicability of drying wood to the moisture-free state without alteration, and (b) to make careful heat determinations by use of modern apparatus.

Samples of dry, well-seasoned wood in the form of fine sawdust were maintained at 105°C. for periods of 1 to 7 hr. Atmospheres of air and of carbon dioxide were used. It is evident from Fig. 58 that a substantial equilibrium is established at this temperature after 1 hr. A small increase in the air-drying loss is noted up to the end of the third hour. In the use of carbon dioxide as the atmosphere of the oven (not shown) the same percentage of loss is reached at the end of 3 hr., after which the lines are practically straight.

In another set of experiments at 137°C., in an atmosphere of carbon dioxide, the total loss again occurred during the first hour, but these values were in most cases a trifle higher. The conclusion suggests the probability of a slight loss of volatile constituents other than water at the higher temperature. This was verified

¹ GOTTLIEB, *Jour. prakt. Chem.*, vol. 28, p. 412, 1883.

² PARR and DAVIDSON, *Ind. Eng. Chem.*, vol. 14, p. 935, 1922.

by repeating the drying on a few samples, using the higher temperature with an atmosphere of air, and collecting and weighing the water discharged. The weight of water obtained was uniformly less than the total decrease in weight, verifying the point that some volatile constituents of the wood other than water are

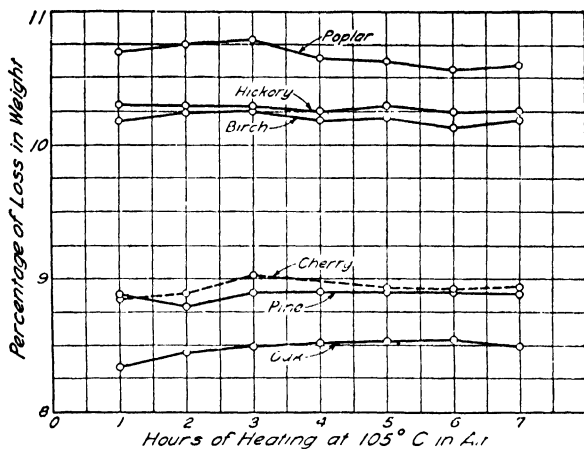

FIG. 58.—The effect of heat on the moisture in wood.

discharged at 135 to 140°. This material is so small at this temperature, averaging about 0.3 per cent, that it is considered negligible at a drying temperature of 105°. It is of the same order of difference between water and volatile constituents as the material commonly recognized as being discharged from coal under the same conditions of drying.

TABLE XX.—HEAT VALUES OF AMERICAN WOODS

Wood	Moisture 1 hr. at 105°C., per cent	B.t.u. per pound, "as received"	B.t.u. per pound, "dry basis"
Pine.....	8.88	8,050	8,836
Oak.....	8.35	7,841	8,556
Hickory.....	10.30	7,578	8,448
Cherry.....	8.85	7,860	8,623
Birch.....	10.18	7,597	8,458
Poplar.....	10.69	7,716	8,640

Calorific values were determined with the moisture content taken after one hour's drying and the heat values were calculated to the dry basis. The calorimeter used was of the Mahler type, platinum lined and under adiabatic control. Table XX shows the actual moisture content of well-seasoned wood of several varieties and the heat values calculated to both the "as received" and the "dry," or "moisture-free," basis.

CHAPTER XIX

LIQUID FUELS

Petroleum.—Petroleum constitutes by far the predominating type of fuel available in liquid form.

Historical.—This material has been known in Persia, China, Japan and near Baku on the Caspian Sea since the earliest times. In 500 B.C. Herodotus wrote of the Springs of Zante which are still flowing. Pliny, about the middle of the first century, refers to the oil of Agrigentum, which was used in lamps for lighting, under the name of "Sicilian Oil." The wells of Amiano in the Duchy of Parma in Italy formerly supplied oil for light in the city of Genoa. Reference to petroleum in America was first made in Sagard's "Histoire du Canada." A letter from a Franciscan missionary refers to oil springs in what is now Allegheny County, N. Y., and also from Oil Creek, now in the State of Pennsylvania, which was used by the Indians for medicinal purposes and later known as Seneca Oil.

A similar oil from shale distillation was introduced into commerce by James Young of Scotland in 1850. It was recovered from Torban Hill shale, more commonly known as boghead coal. This industry rapidly extended to the United States where, in 1860, there were 40 establishments along the Atlantic Coast in New England using, for the most part, boghead coal from Scotland. West of the Alleghenies the rich cannel coals of Breckenridge and Westmoreland counties were extensively employed in the production of kerosene, the largest plant being in the latter county at Lucesco and having a capacity of 6,000 gal. a day.

From so far back as 1790, wells were drilled for salt brine along the western slope of the Alleghenies and these were occasionally contaminated with oil which spoiled their usefulness for their own original purpose. Doubtless the growing industry of distilling oil from the rich coals of that region started the interest in

prospecting in the hope that a supply of natural oil might be discovered which would compete with the distillation process. The Pennsylvania Rock Oil Company was organized for this purpose in 1854. After 4 years of fruitless attempts, their holdings on Oil Creek were subleased to some of their stockholders who employed Colonel E. L. Drake to put down some sort of well to a greater depth than had been known up to that time, in the hope of reaching a supply of oil beyond the mere seepage yield of that day. Drake's first attempt, near Titusville, was that of digging, but this had to be abandoned on account of quicksand. In the bottom of the well he drove an iron pipe which reached bedrock at 36 ft. After a year of effort, finally, with the use of a drill to penetrate the rock, oil was reached at a depth of 96 ft. from the surface. This was on Aug. 29, 1859. The industry developed rapidly while coal distillation, of course, soon disappeared. At the Troy meeting of the American Association for the Advancement of Science in August, 1870, T. Sterry Hunt reported that in the first 10 years there had been produced from the hundreds of wells drilled throughout the Allegheny region a total yield of 28,000,000 bbl., and they had reached an output of 4,500,000 bbl. per year.

The first scientific report on the petroleum from the Venango Company oil field was by B. Silliman, Jr., professor of general and applied chemistry at Yale College. It was written in April, 1855, and was entitled "A Report to the Projectors of the First Association ever formed for Developing this Industry," which may account for the fact that it was not published at that time. The study was made, of course, on samples of seepage oil, and the full report was given in the *American Chemist* for July, 1871, with an editorial introduction by Professor Chandler which reads:

We reproduce the report of Professor Silliman precisely as it was written, and it must, in justice to the author, be remembered that he then had no guide but his own sagacity in the conduct of this interesting research.

The report of Professor Silliman makes interesting reading today after 75 years, because of his remarkable insight and development of the properties of petroleum.

Production.—It is interesting to compare the present-day drilling of oil wells, which occasionally approaches and even exceeds 1½ miles in depth. But more impressive still is the production of this remarkable fuel, especially in America, when shown in comparative form with other oil-producing

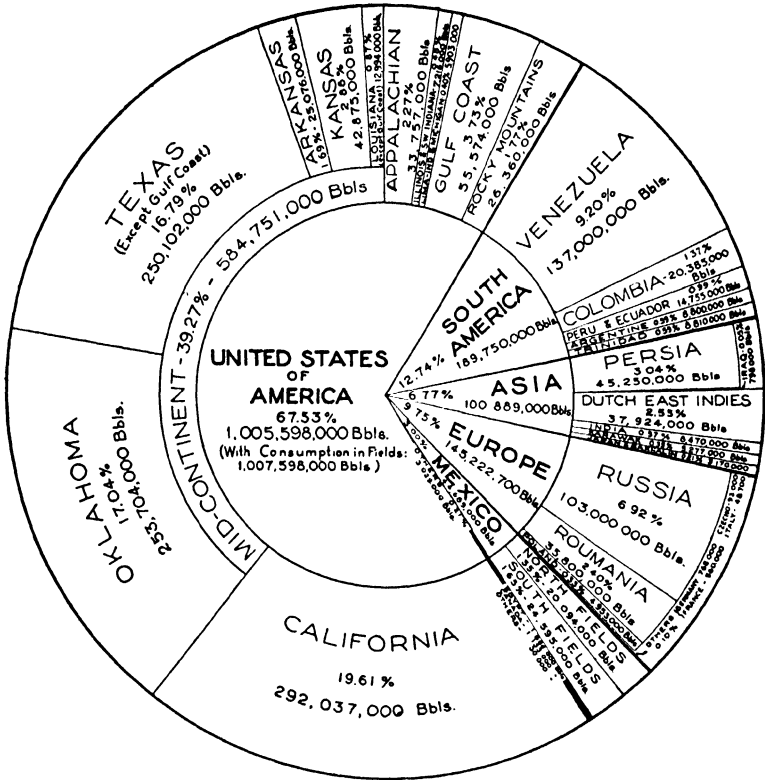

FIG. 59.—World production of petroleum, 1929.

regions. This is well shown in the chart, Fig. 59, reproduced by courtesy of *The Lamp* of the Standard Oil Company of New Jersey.

By 1899, after 40 years of production, the annual yield amounted to 57,000,000 bbl., while at the present time in the seventieth year of production the amount is 1,005,598,000 bbl. or 67.53 per cent of the total of the world's output.

Refining.—Until about the year 1900 the main products from the refining of oil were:

Gasoline, chiefly for use in cooking stoves.

Kerosene, for use in lamps as a lighting medium.

Lubricating oil, for machinery.

Gasoline was at first obtained by "topping," that is, diverting the first fraction obtained from the stills up to about 450°F. This amounted to more with some oils than with others, and for the first 30 or 40 years of refining probably did not average over 9 or 10 per cent. During that period, the accent was placed rather upon the yield of kerosene fraction for the reason that the demand for kerosene in lamps was greater than the demand for gasoline in stoves. Indeed, to prevent accession of gasoline into the kerosene fraction, strenuous laws were passed to prohibit any of the gasoline being mixed with the kerosene because of the explosive property which it would impart. With the rapidly expanding use of the automobile, the demand for gasoline stimulated the search for methods of increasing the gasoline yield. Cracking methods have brought the amount up to 40 and even 60 per cent of the crude oil in some cases, and hydrogenation processes occasionally refer to percentage yields of 105 and more.

The gasoline production for 1929 is given as 43,115,000 bbl., representing a total yield for the entire crude production of 39.4 per cent, not taking into account the gasoline condensed and recovered from gas wells. This is doubtless counterbalanced by the amount of crude which is sold direct for fuel or which, at the most, is subjected to the topping process only.

Some of the lighter fractions, such as pentane and butane, which are too light to be included with the gasoline and too heavy to remain in the gaseous state, are now transported in specially designed tank cars, under pressure of about 40 lb. per square inch and, for smaller distribution and use, in pressure tanks of 10- or 20-gal. capacity.

Other Liquid Fuels.—Other sources of fuel of the liquid type at the present time are of little consequence in view of the seemingly unlimited supply of petroleum oil. Tar as a by-product from the coking of coal is used as a fuel to a considerable extent in metallurgical operations, but this use is practically

all confined to the immediate vicinity of the plant where the tar is produced.

Alcohol at one time seemed likely to enter the field for use in internal-combustion engines, but the cheaper and far more abundant hydrocarbons, as well as the demand for synthetic alcohols as solvents for lacquers, has diverted such material for the present, at least, from use as fuel. Any fuel of the alcohol type, it should be remembered, has a lower heat value per unit of weight in direct proportion to the amount of oxygen in the composition of the substance. For example, methanol (CH_3OH) would have as combustible material CH_2 , while the residual H_2O would be without heat value. Table XXI gives a list of the calorific values of various liquid fuels.

TABLE XXI.—CALORIFIC VALUES OF LIQUID FUELS

Substance	B.t.u. per Pound
Pure Compounds:	
<i>n</i> -Pentane (C_5H_{12})	20,806
<i>n</i> -Hexane (C_6H_{14})	20,708
<i>n</i> -Heptane (C_7H_{16})	20,678
<i>n</i> -Octane (C_8H_{18})	20,588
Benzene (C_6H_6)	18,067
Methyl alcohol (CH_3OH)	9,063
Ethyl alcohol ($\text{C}_2\text{H}_5\text{OH}$)	12,835
Commercial Material:	
Petroleum ether	21,987
Gasoline	20,250
Kerosene	19,980
Fuel oils, heavy petroleum	18,630
Alcohol, 7 to 9 per cent water and denaturant	11,619

CHAPTER XX

BOILER WATERS—THEIR CHARACTER AND TREATMENT

The type of water used for the generation of steam in power plants is of fundamental importance. Until 30 years ago emphasis was placed mainly on boiler scale and methods for its removal or prevention. With increased ratings and higher pressures, cleaner boiler surfaces were demanded which in turn required more efficient treatment of the water and more complete removal of the scale-forming material. This has brought new and more exacting requirements as to the character of mineral constituents, and new classifications of types and, indeed, new emphasis on water constituents and water analysis, both as to the ingredients of the water in the raw state and also as to their changes and behavior under the conditions of higher pressure and temperature.

Water Analysis.—Waters are examined for two very different purposes. First, the object may be to determine the potability or sanitary character of the water; second, it may be desired to learn the behavior or value of the water for industrial uses. The requirements under each division are distinctly different. In order to be sanitary a water must be free from certain forms of organic matter which might indicate possible contamination with sewage or furnish a suitable breeding medium for disease germs. Within reasonable limits, the amount of mineral constituent is of little importance. On the contrary, however, the value of a water for industrial purposes depends very largely on the kind and amount of the dissolved mineral substance, while as a rule little importance is attached to the organic material present. This is especially true in the case of those waters which are to be used for boiler purposes, and it is this phase of the subject which is of immediate interest.

Source of the Mineral Constituents.—Natural waters in passing through the soil come in contact with certain products

of decomposition and decay. Some of these substances, notably carbon dioxide, humic acid, etc., are taken up by the waters, in which condition their power to dissolve mineral matter is greatly increased. In this way the decomposition of feldspar, limestone, etc., is constantly going on, the result to the percolated water being that there is taken into solution varying quantities of silica, salts of iron, aluminum, magnesium, sodium, potassium, etc. As a rule, therefore, the less contact natural waters have had with the soil, or the more insoluble the earthy matter with which they have come in contact, the smaller will be the amount of mineral constituents dissolved; and, conversely, the deeper the source of supply the greater the opportunity for dissolving such material and, consequently, the greater will be the amount of such substances in solution. For this reason it has been customary to divide waters into three classes:

1. Surface waters.
2. Shallow wells and spring waters.
3. Deep wells and artesian waters.

Surface waters are such as are found in lakes, streams and artificial ponds, and with these might also be considered cistern or rain waters.

Shallow-well waters may be considered as those obtained from wells or borings which extend into the drift not to exceed 30 or 40 ft.

Deep-well waters may be considered as those that are obtained from a depth of over 100 ft. These divisions are not sharply drawn and the classes merge into each other. This is more readily seen from the fact that many streams, for a large part of the year at least, are fed by waters which have their source in tile drains and springs. The system of underground drainage so largely carried on in these days therefore gives to the waters of smaller streams many of the characteristics of the water from the shallow wells. This feature is more pronounced during the dry months of the year as, for example, in the late summer and fall. The amount of mineral matter varies, therefore, inversely as the volume of water in these minor streams.

On the other hand, large bodies of water and larger streams, especially those in districts where they come in contact with the more insoluble formations, are remarkably free from mineral

matter. This is especially noticeable in the waters of Lake Superior and in many of the rivers of the north-central part of the United States. In certain regions also, as in the delta of the Mississippi, water-bearing sands are sometimes found at very considerable depths but with extremely small amounts of mineral matter present.

It will be seen from the above discussion that classification based merely upon the source of a water will have little practical value. Before attempting any classification based upon the character of the dissolved mineral constituents, however, it will become necessary to review the processes by which these substances become a part of the water and to note their properties and behavior under the conditions of actual use in steam boilers.

Chemical Characteristics of the Mineral Constituents.—Calcium carbonate (CaCO_3) and magnesium carbonate (MgCO_3) are the chief constituents of lime rock. Finely divided particles of these substances exist throughout all of the clay deposits of the drift region. The percolating water holding carbon dioxide (CO_2) in solution has the property of a weak acid, $\text{H}_2\text{O} + \text{CO}_2 = \text{H}_2\text{CO}_3$, and in this form is a solvent for the above substances, forming bicarbonates, thus:

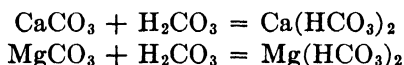

These dissolved bicarbonates are readily broken down by heat, thus:



The water alone with the carbon dioxide gas driven out of it is not a solvent for calcium carbonate, and the latter is precipitated.

Feldspars of various sorts are usually distributed throughout the drift deposits. These also are slowly decomposed by carbonated waters thereby adding to the water compounds of sodium, potassium, iron and aluminum, as well as hydrated silica which is also soluble. The general type of this reaction may be shown thus:

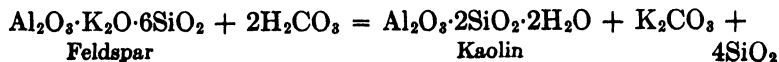

In this way complex or impure rocks may, upon their decomposition, yield small quantities not only of lime and magnesium in solution as bicarbonates, but also iron in a bicarbonate form, as well as salts of sodium, potassium and silicic acid. This result would be more readily understood if we were to enter into a study of the composition of the drift, especially of a region like the Mississippi Valley where the glacial clay has a very considerable admixture of ground rock such as feldspar, hornblende, mica, dolomite, etc. Moreover, since most sedimentary formation has been deposited in contact with or by means of sea water, we expect a greater or less amount of mineral substances to be present due to such water, namely, sodium chloride, calcium sulfate, etc.

Solubility of Gypsum.—We are familiar with the solubility of sodium chloride, but calcium sulfate or gypsum is also soluble, although to a less degree and this without the aid of carbon dioxide. At ordinary temperatures the solubility of gypsum is about 2 grams per liter of water.

From the above facts it may be readily understood how the mineral constituents come to be dissolved in all underground waters. The kind, amount and properties of these substances indicate directly the behavior of a water when used for boiler purposes. Almost without exception their presence is objectionable for reasons which will be evident from the following discussion.

Effect of Impurities.—The mineral impurities in water used for steam generation impart specific properties, such as the formation of scale or of sludge, foaming in the boiler, corrosion of the tubes and drums and, under some conditions, cracking and failure of the boiler plate. These effects follow certain types of mineral matter which divide waters into three classes.

Classification of Waters. *Class I.*—This class includes such waters as have present free sodium carbonate or more than enough sodium to unite with the sulfate, chloride and nitrate radicals or ions. There would be left only carbon dioxide (CO_2) to unite with the remaining sodium and also the calcium, magnesium and iron. Such waters have only temporary hardness, there being no sulfates of calcium or magnesium. Upon boiling or using in the steam boiler, only sludge forms instead of scale.

The carbonates are in the bicarbonate form, and hence are stable in the cold but decompose upon heating. These waters come largely from deep wells and were scarcely, if at all, met with when water supplies came mainly from the surface and shallow wells. Waters of this type, especially in regions of geological drift deposits, are now very common. Also certain methods of water softening reproduce this type in effect with characteristic results of such importance as to require special discussion in Chapter XXI under the heading Embrittlement of Boiler Plate.

Class II.—The waters of this class contain calcium or magnesium sulfate as well as bicarbonates but not the chlorides of these elements. They have, therefore, permanent hardness as well as bicarbonate hardness, and the predominance of one or the other gives character to the scale which forms. A loose, porous scale results where the bicarbonates predominate, while sulfate hardness promotes the formation of a hard, flinty scale. These waters are usual in surface supplies and in most shallow wells.

Class III.—This class includes waters that contain corroding salts or free acid in solution, such as the chlorides or nitrates of magnesium or calcium, the sulfate of iron or free sulfuric acid. Such waters are infrequent but because of their corroding character should be recognized when met.

Examples of the three classes of waters are shown by the representative analyses in Table XXII.

TABLE XXII.—ANALYSES OF VARIOUS TYPES OF WATER SUPPLY

Class	Mineral content, parts per million						
	Residue	Na ₂ CO ₃	MgCl ₂	MgSO ₄	MgCO ₃	CaSO ₄	CaCO ₃
I	464	68.6	146.8	210.4
I	730	225.7	89.0	168.4
II	288	10.5	113.9	110.5
II	1,448	251.1	352.6	171.7
III	432	3.1	37.1	126.0	192.0
III	511	22.1	106.9	63.3	276.2

Effect of Scale.—Boiler scale is a disadvantage for the reasons that: first, it decreases the over-all boiler efficiency; second, it promotes the formation of a high temperature in the plates, with a possibility of softening the same; third, the sudden rupture or opening up of the scale may admit water to the highly heated metal, forming hydrogen and oxygen; fourth, the higher temperature of the steel thus maintained, even though not reaching the danger point, promotes the absorption of sulfur and oxygen and thus causes a deterioration of the metal. Doubtless in the past the chief item in this list, by reason of its continuous and total aggregate effect, has been the decrease in over-all boiler efficiency requiring a larger amount of fuel. Authorities differ as to the extent of loss. A conservative estimate would place the loss of fuel at 10 per cent for each $\frac{1}{16}$ in. in thickness of the scale. The difficulties attending the estimation of the fuel loss are great, and it is to be expected that a rather wide range of results is found in the published data.¹

Within recent years, owing to the increase in steam pressures, and the resultant increase in capital investment, the importance of reduction in boiler outage has been stressed. Consequently scale must be reduced to a minimum, since the boilers are not out of service for a sufficient time to allow for removal of the scale. It is not unusual for boilers to operate continuously for 10 months without requiring cleaning.

Corrosion Sources.—Much disagreement exists regarding the causes of corrosion. Certain conditions will produce galvanic action between different metals used in construction, or even between different parts though made of the same metal, and this action eats away the metallic surfaces. Flaws, cinder scales, oxide nodules, etc., will probably, for a similar reason, produce pitting. Along sharp angles of construction, where the metal

¹ BRECKENRIDGE, L. P., The effect of scale on the evaporation of a locomotive boiler: *Railroad Gazette*, vol. 31, new ser., p. 60, 1899.

Proc. Am. Ry. Eng. Assoc., 1914, p. 692: “. . . it is concluded that the saving of \$977 per locomotive represents 7 cts. per pound of excess scaling matter entering the boiler . . .”

Univ. Ill. Eng. Expt. Sta., *Bull.* 11, 1907.

Am. Ry. Eng. and Maint. Way Assoc., *Bull.* 83, pp. 41ff., January, 1907.

PARTRIDGE, E. P., Formation and properties of boiler scale: Univ. Mich. Eng. Research, *Bull.* 15, June, 1930.

has been put under strain, corrosion will frequently occur. Carbonic acid gas or oxygen when dissolved in water are solvents for iron. Of course, the heat soon drives these gases out of the water but corrosion in the vicinity of the feed inlet may be due to this cause. Some waters percolate through culm heaps or coal-mine refuse or drainage and have produced in them free sulfuric acid from the oxidation of iron pyrites, or they may take up sulfate of iron or aluminum, all of which chemicals render a water positively and vigorously corroding.

Nitrates are seldom encountered but when present in any considerable amount are strongly corroding. Calcium and magnesium chlorides are also strongly corroding. Yet, after all, it may be noted that many conditions can exist to neutralize the corrosiveness of a water. For instance, there may be formed a hard, dense scale which will effectually protect the iron. In this case, however, we would expect to see some tendency toward corrosion and pitting under the scale.

Foaming.—The non-scaling or foaming ingredients are considered to be the salts of the alkalies, such as sodium chloride, sodium sulfate, sodium carbonate, potassium chloride, potassium sulfate, potassium carbonate, etc. Other conditions contribute to the tendency of water to foam, such as the presence of organic matter, especially such substances as may form soap. The presence of finely divided solids in suspension is also a contributing cause.

The causes which promote foaming are not so easy to define or classify as in the case of scaling, and they do not always relate directly to the character of the dissolved mineral substance.¹ The tendency to foam varies greatly: for example, with the two general types of boilers employed, those used for stationary purposes and the locomotive type. It might be said that to the above mentioned conditions of the water might be added the nature of the spaces in which the generation of steam takes place. A network of stay bolts and braces in a steaming space of small volume at best will be more conducive to foaming than an open drum. The structure and steaming capacity of the locomotive therefore greatly increase the tendency of this type of boiler to foam. Tests on numerous railroads generally agree

¹ FOULK, C. W., *Ind. Eng. Chem.*, vol. 21, p. 815, 1929.

upon the following facts concerning the foaming in locomotives. When the mineral content of the water due to the presence of alkali sulfate or chloride reaches approximately 100 grains to the gallon, foaming is apt to occur, especially when the engine is put under heavy work. This means that, in the raw water before condensation has been carried on, a content of 25 grains per gallon would reach the foaming stage when three or four tankfuls had been taken into the boiler. However, a wide variation is due to the type of foaming ingredients, since a less amount of alkali salt will cause foaming where part of the substance is alkali carbonate (Na_2CO_3) or soda ash. Where much organic matter also is present a still smaller amount of free alkali will cause foaming. Cases have been met where 15 to 25 grains per gallon of alkali salts have produced foaming, when, for example, one-half of such salts were in the form of alkali carbonates accompanied by a very considerable amount of organic matter. Foaming in stationary boilers would scarcely be caused by double the amount mentioned above.

The objections to foaming may be stated as follows: first, the rising of the water in the gage glass or blow-off cocks makes it difficult if not impossible to know the height of the water in the boiler; second, the discharge of wet steam or of steam carrying a considerable quantity of water is exceedingly wasteful of heat and makes it difficult to keep up the steam pressure; third, there is danger of large quantities of water getting into the cylinders where, by reason of its incompressibility and inability to pass quickly out of the ports, a cylinder head may thereby be blown off; fourth, the grit carried along with the water promotes the cutting of the walls of the cylinders and valve seats, thus making a reborring of the cylinders necessary; and, fifth, where steam is used in steam turbines, the entrained solids deposit on the turbine blades and these cause a marked reduction in the efficiency of the machine.

The Chemical Treatment of Boiler Waters.—From what has preceded it will be readily understood that the treatment of boiler waters must follow closely along the line of the chemical character of dissolved ingredients, with a view also to the properties which various ingredients impart to the water. In the first instance it must be remembered that all natural water is

strongly impregnated with carbon dioxide. We should recall again the fact that the presence of this gas in the water has furnished a solvent condition which has resulted in the formation of bicarbonates, especially of lime, magnesium and iron.

In 1766 Cavendish announced the discovery that lime water added to certain hard waters would soften them, but the practical application of the principle was not made until 1841, when Dr. Thomas Clark, of Aberdeen, Scotland, obtained patents covering both the process and the apparatus employed. Clark's process has now mainly historic interest. It was ineffective on waters with sulfate or permanent hardness. While his methods seem crude in comparison with present-day processes, certain features have attained a permanent place in boiler-water literature. One is the use of lime and another is the use of a standard soap solution for measuring the total hardness in degrees, each degree representing 1 grain per Imperial gallon of soap-destroying material. This is known as Clark's scale of hardness. Numerous other methods are in use for indicating hardness of water.

It is at once evident that there are two general types of waters, *viz.*, those of Class I and Class II as referred to above under Classification, which have material in solution of two different characteristics requiring two different processes when softening methods are involved.

Because of the fact that the compounds of the first group of substances are easily decomposed by heat and thus discharged from solution, we have a subdivision of scaling ingredients into:

I. Those which are designated as constituting temporary hardness.

II. Those which constitute permanent hardness of water.

The first division is present in almost all waters and includes the larger part of the scaling matter. The latter is variable in amount and frequently absent so far as the scaling constituents are concerned. These two general divisions of types of scaling material must be borne in mind because they form the basis of all practical methods for water treatment; each division represents a process or a method which must be followed for the removal of these substances. This may be more clearly illustrated by the outline in Table XXIII.

TABLE XXIII.—SCALING MATTER AND TREATMENT

Scaling matter is principally composed of	{	Division I. Bicarbonates as:	{	"Excess" CO ₂	{	For this division use	{	CaCO ₃ + 2H ₂ O
						Ca(OH) ₂ .		CaCO ₃ + CaCO ₃ + 2H ₂ O
				Ca(HCO ₃) ₂		The results are		Mg(OH) ₂ + CaCO ₃ + 2H ₂ O
				Mg(HCO ₃) ₂				FeCO ₃ ¹ + CaCO ₃ + 2H ₂ O
				Fe(HCO ₃) ₂				
		Division II. Sulfates as:	{	MgSO ₄	{	For this division use	{	MgCO ₃ + Na ₂ SO ₄
						CaSO ₄		
				FeSO ₄		The results are		FeCO ₃ ¹ + Na ₂ SO ₄

¹ This substance quickly breaks down into Fe(OH)₃, thus:

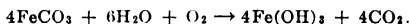

It will be readily seen from this outline that the first division carrying the bicarbonates may be removed from the water either by heat or by the addition of some chemical which will absorb the "excess" and "bicarbonate" carbon dioxide. If we were to depend upon heat for this work, it would be a long process for the reason that ordinarily these bicarbonates are not completely broken down except upon rather prolonged boiling of 15 or 20 min.; this again would indicate the impracticability of such a method because of the expense involved.

Treatment with Lime, Ca(OH)₂.—Since hydrated lime reacts at ordinary temperatures and moreover is the least expensive of the possible reagents, it is made use of to react with the CO₂ of Division I of Table XXIII.

In measuring the amount of Ca(OH)₂ needed for treating a water it must be borne in mind that it reacts with the CO₂ dissolved as H₂CO₃ just as it does with the bicarbonates. Hence we have a series of reactions, thus:

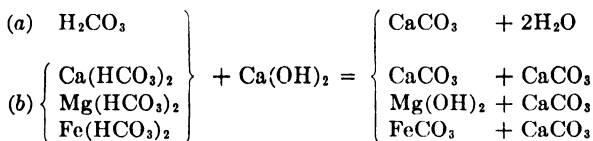

The total CO₂ to be thus taken care of is designated as (a) excess or "free" carbon dioxide and (b) "half bound" or one-half of the bicarbonate carbon dioxide. Estimation of the free and bicarbonate carbon dioxide would represent all of the conditions to be taken into consideration in connection with the lime treatment, except for the slight irregularity in the behavior of one

compound. The magnesium carbonate, especially in the presence of other salts, is soluble to an extent which makes it advisable to carry the reaction one step further and provide for the formation of magnesium hydroxide which compares favorably as to insolubility with the calcium carbonate. This is effected by adding enough extra $\text{Ca}(\text{OH})_2$ to correspond to the magnesium present. By direct determination, therefore, of the magnesium and the calculation of the same to the calcium carbonate equivalent we have the necessary correction indicated for this element.

Having determined the amount of excess and bicarbonate carbon dioxide plus the magnesium, in terms of CaCO_3 , the amount of reagent as CaO for the total CaCO_3 equivalent would be in the ratio of 56:100. To transfer to a unit of 1,000 gal., multiply values for 1 gal. by 1,000, and to transfer grains to pounds avoirdupois, divide by 7,000. Hence, $\frac{1}{7}$ of $\frac{56}{100}$ or 0.08 times the grains per gallon of total calcium carbonate equivalent represents the pounds of CaO reagent needed for each 1,000 gal. of water in removing or correcting these ingredients.

Where the lime is added in the form of a clear solution of $\text{Ca}(\text{OH})_2$, the latter is dissolved to the point of saturation and this concentrated solution becomes the reagent.

The solubility of CaO is about 78 grains per gallon cold (60°F). Hence $\frac{1}{78}$ gal. of *lime water* contains 1 grain of CaO , and $\frac{7000}{78}$ would represent the number of gallons necessary to hold 1 lb. of CaO in solution. Therefore,

$$\frac{7,000}{78} \times \frac{8}{100} \text{ or } 7.18 \times \frac{\text{the grains per gallon of } \text{CaCO}_3}{\text{equivalent}} = \left\{ \begin{array}{l} \text{Number of gallons saturated lime water required to remove the total calcium carbonate equivalent in 1,000 gal. of water.} \end{array} \right.$$

The solubility of CaO decreases as the temperature of the water increases. It should be remembered also that CaO slakes to $\text{Ca}(\text{OH})_2$ and it is really the solubility of the latter compound which is involved.

Recently the market has come to be supplied with pulverized dry lime in the hydrated form. To find the solubility by weight

of this material, calculate the above amounts to the equivalent of $\text{Ca}(\text{OH})_2$. Thus,

$$\begin{array}{ccccccc} 56 & : & 74 & :: & 78 & : & x \\ \text{CaO} & & \text{Ca}(\text{OH})_2 & & \text{gr. CaO} & & \text{gr. Ca}(\text{OH})_2 \end{array}$$

whence 78 grains CaO = 103 grains $\text{Ca}(\text{OH})_2$, which would represent the solubility per gallon at 60°F. of pure material.

In the case of common or commercial reagents used in water treatment, the impurities, of course, must be allowed for.

Treatment with Soda Ash, Na_2CO_3 .—Of the substances sufficiently cheap to be available, sodium carbonate or “soda ash” is by far the best adapted for Division II of Table XXIII, or those ingredients causing the permanent hardness of the water. No reaction or change in solubility by heating can be effective, though many attempts to remove the sulfate by reason of the lesser solubility of calcium sulfate in hot water have been attempted. With this class of substances it is more effective to remove them as carbonates, but this must be brought about by the addition of a soluble carbonate salt, the cheapest of which is sodium carbonate or soda ash (Na_2CO_3) as above indicated.

The analysis of water to determine the amount of soda ash necessary for the precipitation of the sulfates of magnesium, calcium and iron, or permanent hardness is fully outlined under the Analysis of Boiler Waters in Part II.

The reactions involved in the softening process may be represented as follows:

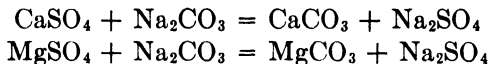

The amount of soda ash used up in this reaction is directly the measure of this substance to be used in treating the water. Where magnesium salts are present as part of the permanent hardness, the MgCO_3 formed as indicated above is to be precipitated as $\text{Mg}(\text{OH})_2$, the same as under temporary hardness. Hence, all magnesium compounds call for an equivalent of $\text{Ca}(\text{OH})_2$ in addition to the primary reagent needed. This, however, is provided for in the method of analysis which determines all of the magnesium, whatever the form in which it is present; and the secondary reagent, $\text{Ca}(\text{OH})_2$, for its removal has

been considered under the preceding topic, *viz.*, Treatment with Lime. A double reaction is thus provided for magnesium, whether the combination be that of a bicarbonate, a sulfate or a chloride.

Treatment with Coagulants.—Coagulants are more frequently employed for the removal of bacterial growths, excessive turbidity and, in some instances, to hasten the rate of softening and give an effluent of lower hardness. The most commonly used coagulants are filter alum, ferrous sulfate and sodium aluminate. When filter alum $[\text{Al}_2(\text{SO}_4)_3 \cdot 18\text{H}_2\text{O}]$, or aluminum sulfate, is added to raw water and an equivalent increase in the lime or soda ash added to neutralize the acidity, a flocculent aluminum hydroxide $[\text{Al}(\text{OH})_3]$ forms. In a similar manner ferrous sulfate ($\text{FeSO}_4 \cdot 7\text{H}_2\text{O}$) produces ferrous hydroxide which is quickly converted to the red flocculent ferric hydroxide $\text{Fe}(\text{OH})_3$ by the free oxygen present in the water. These coagulants are exceedingly effective in carrying down suspended matter. The approximate amount usually employed is $1\frac{1}{4}$ grains per gallon, or about 1 lb. per 5,000 gal. of water. Sodium aluminate tends to form a complex floc without the need of additional alkalinity; when it is used in connection with cold lime-soda softening, the rate of softening is faster and the resulting hardness is usually lower. Thus hardness as low as 1 grain per gallon is easily produced through the use of aluminate and in many instances residual hardness of less than $\frac{1}{2}$ grain results. The floc formed also aids in filtering the treated water.

Industrial Methods.—While in this discussion the reactions in the softening of water have been considered as two distinct processes, in practice they are combined into one operation, that is, the calculated amount of lime for treating, say, 1,000 gal. of raw water has incorporated with it the calculated amount of soda ash and the two reagents are added directly to the water.

Very many mechanical devices for automatically measuring the correct amount of each reagent are in use, depending in the main upon the principle that a given weight or volume of the incoming raw water shall operate certain mechanical arrangements whereby the proper amount of chemical is discharged into the water. The devices are of two general types—the continuous and the intermittent. In the continuous type the raw water flows into

the apparatus and is discharged in the purified form ready for use. In the intermittent type the raw water is made to flow through a mechanical measuring arrangement whereby the chemicals in the proper proportion are added, after which the water is brought into a large settling tank for accomplishing the reactions involved and also for the settling out of the precipitates. Both types are effective, the essential point in any case being that the automatic devices for measuring the reagents be exact and unailing in their operation.

Some processes operate without heating the water, while others heat the water almost to the boiling point. The former usually are intermittent in operation or employ large tanks, while the latter are continuous in operation.

Zeolites.—Certain earthy compounds of the zeolitic type have the property of removing calcium and magnesium from water as it percolates through them. These compounds are hydrated double silicates of aluminum and a base which may be an alkali or an alkaline earth. These bases are readily interchangeable, hence their adaptability to the water-softening process. For example, a water carrying calcium bicarbonate in passing through such a compound with a sodium base will exchange one molecule of $\text{Ca}(\text{HCO}_3)_2$ for two molecules of NaHCO_3 , thus,

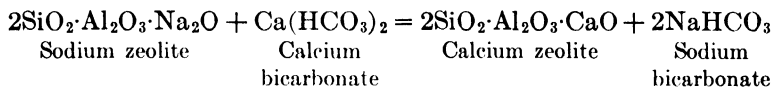

If the water contains calcium sulfate in solution, the reaction takes place in a similar manner, yielding sodium sulfate (Na_2SO_4) to the water in place of the CaSO_4 originally present. When all of the sodium base has been removed, the activity of the zeolite ceases, but it may be regenerated by passing a salt brine through, which restores it to its original activity. Thus,

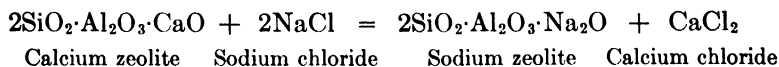

Artificial zeolites with a high capacity have been devised and are extensively used in water-purification systems.

This ability to interchange bases has been found to a greater or less degree in many natural deposits and doubtless is the most

rational explanation for the very widely distributed waters of Class J which are characterized by the presence of free sodium carbonate and temporary hardness only. Many waters, when thus treated artificially with zeolite, take on the characteristics of the natural waters of Class I.

Natural waters of Class I, which were almost unknown previous to about the year 1890, are now common and have been developed as municipal and industrial supplies in many localities.

In his study of the Thanet sands and chalk deposits of the London basin, Thresh¹ concludes that the alkaline waters of that region result from their interaction with the solid material, which he shows to be zeolitic in character.

Numerous other regions in England are known to yield similar waters. This explanation is doubtless applicable also to the waters of the same type so frequently occurring in the drift deposits of the Mississippi Valley.

¹ THRESH, J. C., "The Examination of Waters and Water Supplies" 2d ed., p. 368, 1913.

CHAPTER XXI

THE EMBRITTLEMENT OF BOILER PLATE

Historical.—In an extended study of boiler waters at the University of Illinois, a new type of water supply has been revealed and the difficulties and dangers attending its use have been definitely shown. A complete description of this work may be found in a series of papers and bulletins.¹ A brief summary of these is given here.

Reactions of Sodium Bicarbonate Waters in the Boiler.—The water works at Urbana, Ill., installed in 1884, has its source of supply in a gravel and sand stratum about 165 ft. below the surface. The character of the water is unique in that it is almost free from sulfates but contains the seemingly incompatible mixture of 60 to 70 p.p.m. of free sodium carbonate and approximately 400 p.p.m. of the carbonates of calcium, magnesium and iron. It should be remembered that in natural waters these ions are all present in the half-bound or bicarbonate form and hence are soluble. The water therefore not only has no permanent hardness but is designated as having "negative hardness," in that it is self-purging and forms no scale whatever within the boiler.

Beginning with the year 1895, a series of studies in progress in the Division of Industrial Chemistry at the University of Illinois sought to follow the changes and interactions in the water within a steam boiler, under the existing conditions of temperature and pressure, for the purpose of arriving at an understanding of the processes involved in the formation of scale. The results would also indicate the treatment of the water for scale removal, the

¹ PARR, S. W., The service waters of a railway system: *Jour. Am. Chem. Soc.*, vol. 28, p. 640, 1906; The embrittling action of sodium hydroxide on soft steel: Univ. Ill. Eng. Expt. Sta., *Bull.* 94, 1917.

PARR, S. W., and STRAUB, F. G., The cause and prevention of embrittlement of boiler plate: *idem, Bull.* 155, 1926; Embrittlement of boiler plate: *idem, Bull.* 177, 1928.

STRAUB, F. G., Embrittlement in boilers: *idem, Bull.* 216, 1930.

causes of corrosion and other factors. Two interesting facts developed which were not fully appreciated in the early stages of the investigation. First, because of the opportunity offered for studying the water supplies of several railroads, including the Illinois Central, the Big Four between Indianapolis and Peoria, and the Chicago and Alton, a rather extended geographical zone for this particular type of water was indicated and fairly definitely outlined. Second, in waters of this type, after a few days of use in stationary boilers, where the blow-off is naturally only partial and periodic, the sodium bicarbonate (NaHCO_3) of the raw water does not stop in its process of decomposition by heat

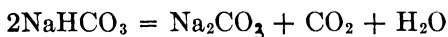

but goes further, a part of the carbonate being hydrolyzed into the hydroxide according to the reaction:

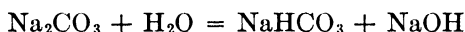

The residual water within the boiler becomes an active reagent for the precipitation of scale-forming material the moment it comes in contact with the fresh incoming water, thus indicating why such waters are self-purging and develop no scale whatever within the boiler. Further significance which might attach to the presence of caustic soda in the boilers did not appear at that time.

The Cause of Embrittlement.—In 1913 an investigation was begun by the Engineering Experiment Station of the University of Illinois to determine the cause of this particular type of failure and to devise methods of preventing its occurrence. The data collected at that time showed that the boilers encountering this difficulty had used well water, and that these well waters contained sodium bicarbonate, and only a small amount of sulfates. The sodium bicarbonate rapidly broke down to form sodium hydroxide in the boiler. As a result of the publication of *Bulletin 94*, the attention of the industry was called to this particular type of boiler distress and much effort has since been expended toward determining the true cause of cracking. Consequently, available data with regard to the more recent instances of embrittlement have been more nearly complete. During the period between

1915 and 1925, boiler failures due to embrittlement occurred in other sections of the United States; the majority of the cases were still found in boilers using well waters containing sodium carbonate. Figure 60 shows the location of power plants using well waters which have encountered cracking of this nature. A few instances of cracking have been found where surface waters were used. It was also found that soda ash treatment or its

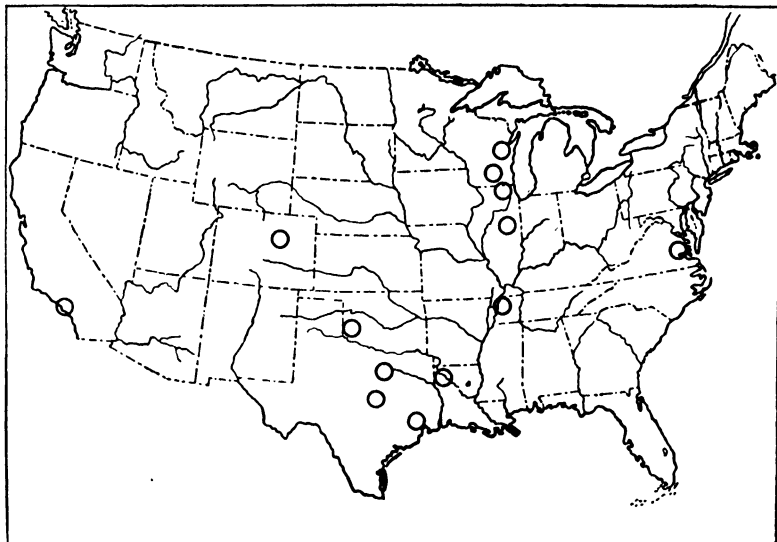

FIG. 60.—Areas in which boilers using well waters have been embrittled.

equivalent had been used for these waters. The boiler waters always had high caustic alkalinity combined with a low sulfate content.

In later experimental work conducted at the University of Illinois, test specimens of boiler plate were made to fail in the same manner as embrittled boiler steel fails. The result of this research may be briefly summarized as follows:

1. Embrittlement in boiler plate is caused by the combined action of stress and chemical attack. The stresses are inherent in the construction and operation of the boiler, while the chemical attack is caused by the presence of sodium hydroxide in the boiler water.
2. Certain methods of water treatment will convert some safe waters into the characteristic type which produces embrittlement.

3. The presence of sodium sulfate in the boiler water retards the embrittling effect of the sodium hydroxide, and if present in proper proportion will stop it entirely.

4. The presence of phosphates, chromates, nitrates, acetates, etc., also inhibits the embrittling action of caustic soda if the concentration ratios are maintained above a certain characteristic minimum.

5. Methods for the introduction and control of the inhibiting agents have been worked out and are in operation in large power plants.

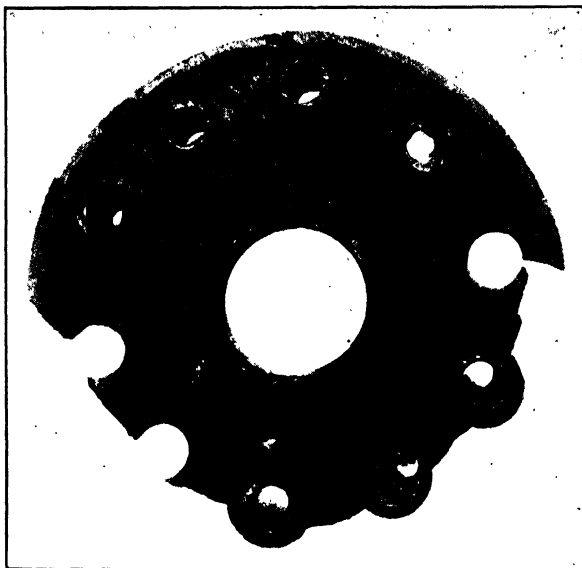
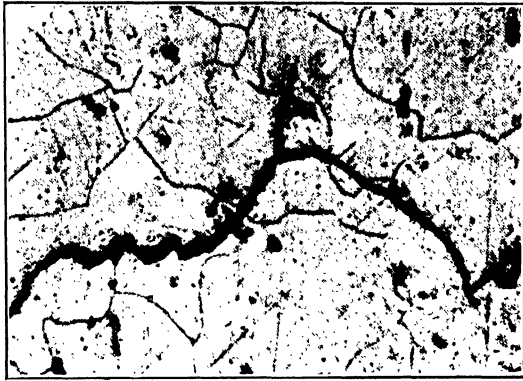

Fig. 61.—Embrittled blow-off flange.

A summary of the chemical conditions which characterize the water used in the boilers where embrittlement has occurred is as follows:

- a. Sodium carbonate is the one substance always present in the feed water.
- b. Sulfate hardness is usually absent or of a low ratio with respect to the sodium carbonate present. Sodium sulfate is similarly lower in amount than the sodium carbonate.
- c. Boilers encountering this trouble use waters having the characteristics noted under (a) and (b) and, as a consequence of chemical reaction within the boiler, develop a caustic condition with the sodium hydroxide in material excess over the sodium sulfate.

The characteristics of embrittlement cracks may be summarized as:



(a)



(b)



(c)

FIG. 62.—Micrographs of fatigue and embrittlement cracks. (a) Fatigue crack in Armeo iron ($\times 350$). (b) and (c) Embrittled rivet heat ($\times 250$); (b) unetched; (c) etched—2 per cent nital. (From *Univ. of Ill. Eng. Expt. Sta., Bull. 216*, pp. 28 and 29, 1930.)

a. They do not follow what is generally considered as the line of maximum stress.

b. They start on what is termed the dry side of the plate.

c. They run in general from one rivet hole to another, though they often run past each other, leaving islands of plate (Fig. 61).

d. They are irregular in direction.

e. They never extend into the body of the plate beyond the lap of the seam.

f. There is no elongation of the plate.

g. Where extreme action has occurred, rivet heads crack off or are easily dislodged by a slight blow of the hammer.

h. Metallurgical examinations of the cracks show that they are always intercrystalline as opposed to corrosion and fatigue cracks, which are transcrystalline (Fig. 62).

A summary of conditions relating to the location of cracks in the boiler may be given as follows:

a. They occur in seams under tension.

b. They are found at places where the highest localized stresses might be assumed to occur.

c. They occur in plates having practically perfect chemical composition and physical properties as well as in plates of inferior make.

The Prevention of Embrittlement.—The University of Illinois power plant experienced embrittlement troubles for some time and when three new drums had to be replaced in 1915, after only 5 years of service, the following system of water treatment was inaugurated.

The sulfate-carbonate ratio of the feed water was maintained at two by neutralizing about 70 per cent of the sodium carbonate alkalinity with sulfuric acid. The water was treated in two 40,000-gal. settling tanks by adding about 110 lb. of lime to each tank; and after sufficient agitation and settling, adding the required amount of acid. Analyses were made of each tank after lime treatment, and again after the acid was added, to determine total alkalinity. Daily analyses were also made of the water in each boiler for causticity and total alkalinity.

After 10 years of operation on this treatment, the boilers were given a thorough inspection during February, 1928. Test rivets were removed and a close inspection was made for signs of leakage or cracks around the rivet holes. At that time the boiler inspector pronounced the drums to be in perfect

condition. The rivets were redriven and the boilers put back in operation.

In comparison, in a power plant in Champaign, Ill., boilers went into service in 1916, using the same water as that at the University but without the sulfate treatment. In 1925, considerable trouble was experienced, owing to embrittlement. These two plants, operating for 9 and 10 years, respectively, using within 20 lb. of the same steam pressure and operating upon precisely the same type of water, one treated with acid and the other not treated, served as a long-time experiment, with results that were strictly in accord with the laboratory indications. The boilers using the treated water are now in excellent condition, while the others were condemned after only 9 years of service.

A system of acid treatment on a continuous-flow principle has been devised and is now in use in several central power plants in the Chicago district. The water is zeolite treated and is low in the sulfate-carbonate ratio. This ratio is raised by allowing a definite amount of dilute acid to flow into a mixing chamber through which a definite amount of water is being passed. A regular chemical analysis of the boiler water is also maintained at these plants.

The A.S.M.E. Boiler Code.—The Boiler Code Committee of the American Society of Mechanical Engineers in 1925 made recommendations with regard to maintaining a definite ratio between the alkalinity and the sulfate content in boiler waters. The following is quoted from the committee report:

The attention of the committee has been called to the following exceptional cases in rivet-joint cracks described as intercrystalline in character, and under the water level only:

a. Boilers in certain localities fed with water containing sodium bicarbonate, but not an appreciable quantity of sodium sulfate (similar cracking has not been reported in the same localities in boilers fed with surface water, free from sodium carbonate or containing sodium sulfate equal to or exceeding the sodium bicarbonate);

b. Boilers fed with water in part composed of condensate from leaky caustic evaporators;

c. Boilers fed with sea-water distillate to which compounds were added, resulting in high concentrations of sodium alkalinity.

In view of the particular cases of embrittlement cited above and pending further research, the maintenance of not less than the following ratios of sodium sulfate to the soda (methyl orange) alkalinity is recommended as a precautionary measure:

Working Pressure of Boiler, Pounds Gage	Relation of Sodium Carbon- ate Alkalinity to Sodium Sulfate
0 to 150.....	1:1
150 to 250.....	1:2
250 and over.....	1:3

Cracks of this particular character have not been reported in cases where water-softening equipment has been intelligently used, maintaining close control over boiler concentrations and the boilers have been properly operated.

Pending further operating data from boilers in service, it is recommended that the requirements of Par. 1-44 of Section VI of the Code be extended to all riveted seams, and that careful examination of all seams be made if leaks occur and do not remain tight after proper calking.

The increasing ratio of sulfate for higher pressures was recommended because it was felt that more hydroxide would form at higher pressures and necessitate the presence of more sulfate. This was merely a rule-of-thumb ratio which had been derived from plant operation.

CHAPTER XXII

LUBRICANTS

Introduction.—Next to the conservation of the world's fuel supply there is probably no subject of greater importance in the manufacturing world than the control of waste power caused by imperfect lubrication and needless friction . . . Archbutt has stated that of the 10,000,000 hp. in use in the United Kingdom of Great Britain considerably more than half this amount, 40 to 80 per cent of the fuel, is spent in overcoming friction, and that a considerable proportion of this power is wasted by imperfect or faulty lubrication.¹

Any substance made use of for the lessening of friction is called a lubricant. By its use the surfaces of sliding bodies are separated by a thin film which permits of easier movement than if the surfaces were in direct contact. Lubricants must therefore vary widely for the different kinds of work involved. For example, the "body" must be suited to the load. Working temperatures, both high and low, must be provided for. Oxidizing or gumming must not be a property of the material, and any tendency to corrode the metal surfaces must be absent.

Lubricants are derived from two main sources:

1. Oils of animal or vegetable origin.
2. Mineral oils.

Animal and Vegetable Oils.—All oils of this class are saponifiable, that is, they are compounds of fatty acids and glycerine. They decompose to a considerable extent on long standing, setting free the fatty acids. Many vegetable oils, such as linseed oil, readily oxidize, forming a gumming substance. Only non-oxidizable oils are suitable for lubrication. Among vegetable oils the best known are olive (sweet) oil and castor oil. Among animal oils, lard oil is perhaps the most common.

Mineral Oils.—These oils are derived from petroleum by distillation. They will not saponify, having no combination of fatty

¹ MABERRY, C. F., *Ind. Eng. Chem.*, vol. 2, p. 115, 1910.

acids, and, when not refined, they will not oxidize to form gumming compounds.

Compounded Oils.—The compounding of oils is an attempt to render a certain oil more effective by mixing with another oil having slightly different properties. Thus, mineral oils may be said to be compounded with an animal oil to impart greater body or viscosity to the mixture; or, a vegetable oil with heavy body but too little fluidity may be compounded with a mineral oil to improve its property in that direction. The peak of the viscosity effect produced by compounding a vegetable oil with a mineral oil is obtained with relatively low percentages of the vegetable oil, probably not over 2 or 3 per cent. Beyond this point the further addition of the vegetable oil may add an expense out of proportion to the benefit obtained. Mineral oils are often compounded with each other to produce certain desired properties. Their oiliness is greatly increased by the addition of small amounts (up to 2 per cent) of free fatty acids. The “mineral castor oils” are mineral oils in which a small percentage of aluminum soap has been added to raise the viscosity. Greases are mixtures of petroleum lubricants with mineral soap, such as lime, sodium, lead or aluminum soaps, to the extent of 10 to 40 per cent. The lead-soap greases give a mixture of great body for heavy machinery, shafting, gears, etc. Aluminum-soap greases are used for pressure-gun lubricants. Finely pulverized mica, graphite or sulfur are often employed with greases. These lend themselves to numerous combinations for the production of lubricants with specific properties. An interesting variation from the usual types is found in Aquadag and Oildag wherein the graphite is so minutely divided that it is possible, by use of deflocculating agents, to form permanent emulsions with both water and oil. This property suggested to Mr. Acheson, who developed the material, the designation of “deflocculated Acheson graphite”; hence the term, Oildag, etc.

For high-temperature service the problem becomes more difficult. An oil must be selected which will not volatilize or decompose at the high temperature employed.

Because of their low cost and the ease with which they may be varied to meet the different conditions as to load, speed and temperature, petroleum and the products which may be derived

therefrom have come to predominate in the entire field of lubricants in America. However, because of the development of processes for distilling, cracking and mixing, it would be impossible to prescribe a chemical composition to conform to any specific type of carbon compounds. Doubtless some forms are more stable than others. Promoters of petroleum lubricants, however, who claim their special oils are without any carbon in their composition, have more zeal than chemical sense.

Testing.—The most common and the best established tests for indicating the suitability of an oil for lubricating purposes are the following:

- a. Viscosity.
- b. Flash and fire test.
 - c. Conradson test for carbonization.
- d. Cloud and pour tests.
 - e. Emulsification.
 - f. Free acid.
 - g. Saponification number.
 - h. Maumené test.
 - i. Specific gravity.
 - j. Color.

Viscosity is due to the internal friction of the oil itself and must increase in amount with the load of the moving parts. No attempt is made to measure the viscosities of lubricants in terms of the viscosity of water as unity, that is, by factors which would represent specific viscosities. Special instruments have been designed which give arbitrary factors only. The end sought has been to devise a method which would give results that were consistent as to their relative values and which could be reproduced with a fair degree of accuracy. For this reason the viscosity number is meaningless unless accompanied with the name of the instrument by which it was determined.

When lubricating oil is to be used over a wide range of temperature, such as that encountered in automobile-engine operation, it is frequently desirable to know the variation of viscosity with the temperature. For example, the viscosity of an oil may be satisfactory at 100°F. and yet it may fall so rapidly that the oil will not give satisfactory lubrication at higher temperatures. Thus it is frequently desirable to determine viscosities at two

or more temperatures. Those usually chosen are 100, 130 and 210°F.

The Society of Automotive Engineers has adopted the standard classification of lubricating oils according to viscosity numbers as given in Table XXIV.

TABLE XXIV.—S.A.E. CLASSIFICATION OF LUBRICATING OILS ACCORDING TO VISCOSITY

S.A.E. viscosity No.	Viscosity range, Saybolt viscosity, seconds		
	At 100°F.	At 130°F.	At 210°F.
10	135- 200	90-115	•
20	220- 330	120-150	•
30	410- 500	185-220	
40	600- 630	255	70 •
50	635-1,000	75- 95
60	1,300-1,800	105-120

The viscosity-temperature coefficient of mineral oils varies widely with their chemical composition, such as the relative paraffinic and naphthenic nature. Dean and Davis¹ have proposed the "Viscosity Index" as a quantitative rating of oils on the basis of this coefficient. They determined the Saybolt Universal viscosities at 100°F. and 210°F. of a series of lubricating oils prepared from each of the two extreme types of crude oil. One series, *H*, had a small viscosity-temperature coefficient and the other series, *L*, had a large one. For the purpose of interpolation an empirical equation relating the value of the viscosity at 100°F. with that at 210°F. was derived for each series. By means of this equation the values for the viscosity at 100° corresponding to each value of the viscosity at 210° were calculated for series *H* and for series *L*. These data are given in Table XV in the Appendix. The viscosity index, V.I., is calculated by the equation:

$$\text{V.I.} = \frac{L - U}{L - H} \times 100$$

¹ DEAN, E. W., and DAVIS, G. H. B., Viscosity variations of oils with temperature: *Chem. Met. Eng.*, vol. 36, p. 618, 1929.

where U is the viscosity at 100°F. of the oil being tested, and L and H are respectively the viscosities at 100° of the series L and series H oils having the same viscosity at 210° as the oil being tested. For example, if the oil being tested has a viscosity of 60 sec. at 210° and 600 sec. at 100°, Table XV shows the values of 426 and 781 for the viscosities at 100° of H and L , respectively, corresponding to a viscosity of 60 sec. at 210°, and

$$\text{V.I.} = \frac{781 - 600}{781 - 426} \times 100 = 51$$

The viscosity index thus calculated is the relative rating of the oil on a scale in which the viscosity indices of two arbitrarily chosen series of oils, L , having a large viscosity temperature coefficient and H having a small one, are rated as 0 and 100, respectively. The larger the viscosity index, the smaller is the tendency of the oil to thin out with rise of temperature. The viscosity index is not related to the S.A.E. viscosity number.

The viscosity index indicates the chemical constitution¹ of the oil and is approximately constant for oils from the same crude. It is independent of the actual viscosity at any temperature.

Newell² has constructed an alignment chart from which the viscosity index may be obtained directly from values of viscosity at two temperatures.

Flash and fire test is of value as indicating the care with which the lubricant was prepared. It is also an index of the adaptability of the oil to use where high temperatures are involved, as in the internal-combustion motor, the high-pressure steam engine and the steam turbine.

The Conradson test is an attempt to measure the tendency of an oil to break down and deposit free carbon under ordinary lubricating conditions. It is based on the theory that upon evaporating a given oil to complete dryness, the residue of carbon remaining will furnish an index of the tendency of the oil to decompose or change its chemical composition in use. The carbon-depositing tendencies of automobile oils can be predicted approximately from the carbon-residue test. This test is significant probably

¹ DAVIS and McALLISTER, *Ind. Eng. Chem.*, vol. 22, p. 1326, 1930.

² *Ind. Eng. Chem.*, vol. 23, p. 843, 1931.

because it is a rough indication of the volatility of the oil at flame temperature.¹

The cloud test is the temperature at which paraffin wax or other solid substances begin to crystallize out, or separate from solution, when the oil is chilled under definite prescribed conditions.

The pour test is the lowest temperature at which the oil will pour or flow when it is chilled without disturbance under definitely prescribed conditions. The pour test indicates the suitability of an oil for low-temperature use, and especially its behavior when an oil-circulating system must be started at low temperatures. It does not, however, indicate the true mobility of the oil at the low temperature after the crystalline network of the congealed oil has been broken down by stirring or other movement. Information regarding the mobility of oils at low temperatures may be obtained by the use of a modified plastometer.²

Emulsification is a property especially to be considered in those systems of lubrication which circulate the oil under pressure and require that it be collected in a filtering and settling chamber for recirculating through the moving parts. It is a ready means for indicating a pure hydrocarbon oil as distinct from one carrying impurities, especially mixtures containing sulfonic residues or the saponified salts of organic acids such as calcium or magnesium soaps. After extended investigation into the significance of emulsification, the American Society for Testing Materials has included this test in its standards for indicating the purity or adaptability of lubricating oils for specific purposes. For some uses as with screw-cutting machines, an emulsifying oil is desired. For forced-feed systems a demulsifying oil is essential.

Oils for steam engines and turbines must separate readily from the condensate after emulsification with steam. The steam-emulsion number is the number of seconds required for an oil to separate when emulsified and separated under the conditions

¹ LIVINGSTONE, C. J., MARLEY, S. P., and GRUSE, W. A., Motor carbon deposits formed under controlled conditions from typical automobile oils: *Ind. Eng. Chem.*, vol. 18, p. 502, 1926.

² PARSONS, L. W., and TAYLOR, G. R., Lubricating value as related to certain physical and chemical properties of oils: *Ind. Eng. Chem.*, vol. 18, p. 493, 1926.

definitely prescribed by the American Society for Testing Materials, Method D 157-28.

Free acid results from carelessness in the refining process. It is therefore presumably sulfuric acid or sulfonic organic compounds formed from the unsaturated hydrocarbons. Either substance is strongly corroding.

Saponification serves as a means for estimating the amount of animal or vegetable oil used in compounding. This with the Maumené test may serve as a fairly reliable method for indicating the kind of fatty oil entering into the mixture.

Maumené test is based upon the heat of reaction of the oil with concentrated sulfuric acid and is a rough indication of the amount of unsaturated compounds in the oil.

The specific gravity of a lubricating oil is an indication of the class of crude petroleum from which it was made. Paraffin-base petroleum usually produces oils having low specific gravity, whereas mixed-base and asphaltic-base petroleums produce oils with a higher specific gravity in the order named. It should be pointed out that the terms "light," "medium" and "heavy" refer to viscosity rather than to specific gravity.

Deterioration of Automobile Lubricating Oils.—Oils do not wear out with use, but they do deteriorate as a result of numerous contributory factors, the more important of which are: crank-case dilution; thermal decomposition with the deposition of free carbon; oxidation resulting in the formation of resinous or asphaltic materials and emulsifying agents which emulsify the oil with any condensed water; development of acidity by oxidation of the oil and by the absorption of oxides of sulfur from the exhaust gases leaking past the piston; and the collection of road dust and particles of metal. Crank-case dilution is caused by the partial condensation of gasoline upon cold cylinder walls and results in the thinning out and loss of viscosity of the oil. This problem of crank-case dilution has received considerable attention in recent years, and methods of measurement are still in the process of development. The student should be guided by the latest A.S.T.M. standard test.

The magnitude of the effect on the viscosity of an oil produced by dilution with gasoline is well shown in Table XXV from Sparrow and Eisinger.

TABLE XXV.—EFFECT OF DILUTION ON VISCOSITY

Dilution, per cent	New oil—viscosity at 100°F.—seconds, Saybolt			
	300	600	1,000	4,000
10	168	315	500	1,450
20	115	178	250	510
30	71	95	125	200
40	44	54	63	83
50	32	45

References

1. SPARROW and EISINGER, Lubrication data from cooperative fuel research: *Ind. Eng. Chem.*, vol. 18, p. 482, 1926.

2. WILSON, R. E., and WILKIN, R. E., Principles underlying the use of equilibrium oils for automotive engines: *Ind. Eng. Chem.*, vol. 18, p. 486, 1926.

3. PARSONS, L. W. and TAYLOR, G. R., Lubricating value as related to certain physical and chemical properties of oils: *Ind. Eng. Chem.*, vol. 18, p. 493, 1926.

4. KOETHEN, F. L., The rôle of graphite in lubrication: *Ind. Eng. Chem.*, vol. 18, p. 497, 1926.

5. DOVER, M. V., Comparison of lubricating efficiencies of oils and some of their physical and chemical properties: *Ind. Eng. Chem.*, vol. 18, p. 499, 1926.

6. LIVINGSTONE, C. J., MARLEY, S. P., and GRUSE, W. A., Motor carbon deposits from typical automobile oils: *Ind. Eng. Chem.*, vol. 18, p. 502, 1926.

7. LIVINGSTONE, C. J., and GRUSE, W. A., Carbon deposits from lubricating oils: *Ind. Eng. Chem.*, vol. 21, p. 904, 1929.

8. WILHARM, W. C., The rôle of oiliness in industrial lubrication: *Ind. Eng. Chem.*, vol. 18, p. 463, 1926.

9. United States Government specifications for oils and methods of testing: U. S. Bur. Mines, *Tech. Paper 323B*.

10. A.S.T.M. standard tests:

Conradson carbon residue.....	D 189-30
Cloud and pour points.....	D 97-30
Flash and fire.....	D 92-24
Saponification number.....	D 94-28
Steam emulsification.....	D 157-28
Sulfur.....	D 129-27
Viscosity—Saybolt.....	D 88-30
Penetration of greases and petrolatum.....	D 217-27T

Precipitation number	D 91-30T
Dilution of crank-case oils	D 322-30T
Color—by Union colorimeter	D 155-23T

(NOTE:—The first number is the number of the test and the second number indicates the year of adoption as standard, or of latest revision.)

11. National standard petroleum oil tables: U. S. Bur. Standards, *Circ.* 154.

12. LOCKHART, "American Lubricants:" The Chemical Publishing Company, Easton, Pa.

PART II

LABORATORY METHODS

CHAPTER XXIII

THE SAMPLING OF COAL

Introduction.—Samples may be taken by different methods and for a variety of purposes. Three kinds are generally recognized:

1. Hand samples.
2. Face samples.
3. Commercial samples.

1. *Hand Samples.*—As the name implies, hand samples are taken in small amounts and the entire sample is submitted for inspection and analysis. In the nature of the case such samples are selected and are not representative of the mass from which they come. Their analysis may be of interest to the person collecting them but the results are without commercial value or significance.

2. *Face Samples.*—This term is applied to samples taken at the working face of a coal seam. They are essential for purposes of scientific study and serve as a basis for determining the changes that occur in the process of mining, transportation and storage. The taking of such samples is not different in principle from the taking of commercial samples. The chief essential is a kit of the knock-down type, not too heavy for packing and not too tedious in setting up and operating. Specific details are not given here.

3. *Commercial Samples.*—The majority of samples are taken in connection with industrial operations, in the process of coal inspection, control of contracts, determination of efficiencies, etc., and this involves the sampling of wagon loads, car lots, barge shipments and masses in storage. The general principles under

any of these conditions are the same. The important features to be observed are given special emphasis as follows:

Necessity of Care.—Without question, the critical point in the entire range of coal inspection and analysis is in the sampling. If the sample taken is truly representative of the entire lot, the results, if accurate in themselves, furnish correct information as to the larger mass of which the sample is a part. If, on the other hand, the sample is in error, the results of the analysis though correct in themselves will be in error so far as they relate to the mass under consideration. Throughout the process of sampling two points must be observed with scrupulous care:

First. The sample taken must be representative of the whole, that is, the distribution of the various substances which go to make up the original mass must be maintained without any change in the relative amount of the various constituents.

Second. The moisture content, which changes readily, must be under exact control so that at any stage the ratio of moisture present to the original moisture of the mass may be definitely known.

Material to Be Taken.—As stated above, the first essential in a sample is that it shall be truly representative of the mass of which it is a part. To secure this result a few fundamental conditions must be observed, as follows:

The gross sample must be representative of the various kinds of material present. That is to say, a mass of coal consists of fine stuff, lump, bone, slate, pyrites and other constituents. As a rule the "fines" differ in composition from the lump, hence the sample must have these two sorts of material in their proper proportion. The same is even more true of slate or pyrites, the composition of which differs widely from that of the major part of the mass. An undue amount of such material would cause a serious disturbance in the accuracy of the sample.

Amount.—In procuring a representative sample a large element of safety resides in the quantity taken. In general, the larger the amount, the more representative it will be. However, conditions differ. It is easier, for example, to procure an even sample from the face of a working vein or from a carload of screenings than from a carload or other mass of lump or run-of-mine coal. In the latter case larger amounts should be taken than in the former.

The limits of practicability for the proper handling of the sample must however be considered. In general, the gross sample should weigh approximately from 200 to 600 lb. Doubtless 200 lb. of screenings, taken with fairly good distribution throughout the unloading of a 40- or 50-ton car, will yield a very true sample. The difficulties increase greatly with the increase of the size of the particles, as in the case of lump or mine-run coal. If mechanical appliances for grinding are available the larger amount should be taken, but a smaller sample well crushed down before quartering is better than a greater mass quartered down while the particles are still in larger pieces.

Ratio of Size to Mass.—Assuming that the sample as taken is made up of the various kinds of material in proper proportion, the next important item is to maintain these variables in their ratios throughout the process of reducing the gross amount to a small working or laboratory sample. To insure this result there must be maintained a certain ratio of size of the particles to size or weight of the mass. This, as a rule, is based on a formula which provides that the weight of the largest piece of impurity shall have a ratio to the weight of the mass of about 2:10,000. For example, a mass weighing 10,000 grams, or about 22 lb., should contain no particles weighing more than 2 grams. This would mean that the largest particle, as, for example, a piece of iron pyrites, must not be over $\frac{1}{4}$ in. in its greatest diameter. Each piece of impurity of this size improperly distributed would represent a possible error of approximately ± 0.02 per cent.

The final ratio of sizes, however, should be determined by the methods available for grinding. With mechanical appliances for obtaining the smaller sizes, a table of ratios with greater safety limits can be adopted than is perhaps practicable where the crushing is done by hand. If a power crusher is available, the entire sample should be passed through the mill and reduced to a size which will pass a $\frac{1}{4}$ -in. screen. If the crushing must be done by hand, the first reduction in size of the particles should be such that the entire mass will pass through a 1-in. screen. When, by quartering, the sample is reduced to 100 lb., the size of the particles should be further reduced to a size that will pass a $\frac{1}{2}$ -in. screen, and with a 50-lb. sample in hand the crushing

should be carried to $\frac{1}{4}$ -in. mesh. The subdivisions with their respective sizes are shown in tabular form as follows:

TABLE XXVI.—SIZE OF MESH FOR DIFFERENT SUBDIVISIONS OF SAMPLE

Weight of Subdivisions of Sample, Pounds	Size of Mesh to Which Each Subdivision Should Be Broken, Inches
500	1
250	$\frac{3}{4}$
125	$\frac{1}{2}$
60	$\frac{1}{4}$
30	$\frac{1}{8}$

Most coals are easily crushed in mills, which are available at little expense. Hence it is entirely reasonable to require that gross samples, when reduced in mass to 50 or 75 lb., shall be

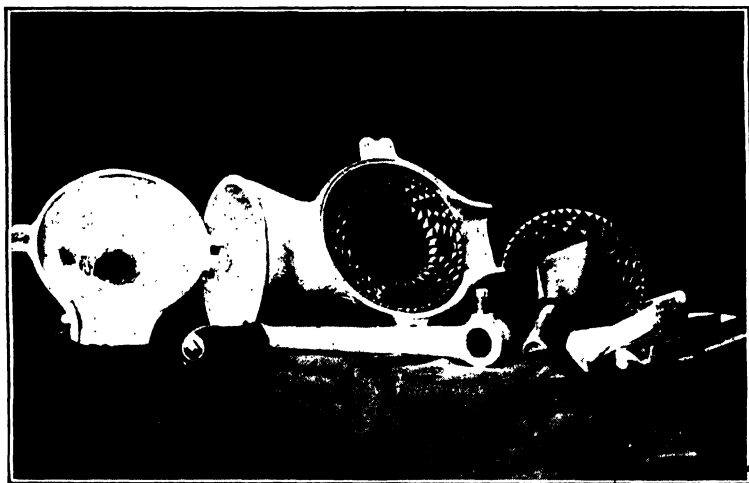

FIG. 63.—Coal grinder of the coffee-mill type.

passed through a mill set for grinding to approximately $\frac{1}{8}$ in. For this work a mill which is not of the jaw-crusher or roller type is preferred, since these types produce too large a percentage of fine material, and the harder pieces of slate, especially those of flaky or plate-like structure, are liable to pass in pieces having inadmissably large dimensions in two directions, even though the adjustment used would seem to be fine enough to prevent the passage of such material. A grinder of the coffee-mill type or

one with projecting teeth on the grinding surfaces will be found to produce a more uniform size and the minimum amount of dust. The grinding surfaces of such a machine are shown in Fig. 63.

Mixing and Subdividing.—As a further precaution in maintaining a correct distribution of the various constituents, emphasis is placed upon the necessity of thorough mixing, followed by an even selection of the remaining subdivisions. It is true that fine grinding contributes materially to this end but further care is necessary. It is entirely practicable to mix a 50-lb. sample; ground as above described, by rolling in an oil cloth about 5 ft.

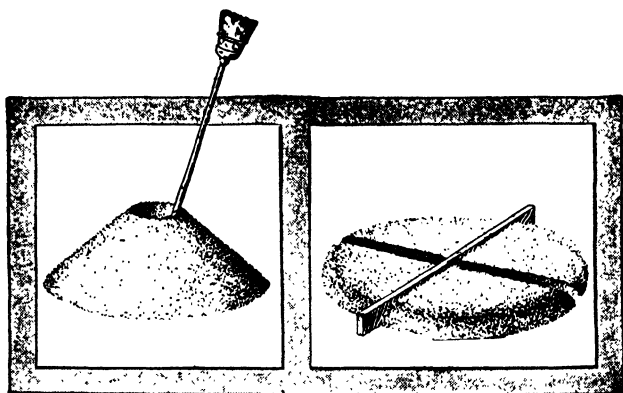

FIG. 64.—Flattening the heap of coal and then quartering the pile.

square. This is accomplished by taking one corner of the cloth and carrying it over the pile towards the diagonally opposite corner so as to cause the mass to roll over upon itself, then reversing the motion and repeating the process with the other two corners. Fifteen or twenty such alterations, depending somewhat upon the size of the sample, should be sufficient to effect an even mixture. After mixing, the process of coning and quartering should be followed as illustrated in Fig. 64. Opposite quarters are rejected until the final sample amounts to about 5 lb. This is sealed in an air-tight container and forwarded to the laboratory for analysis.

The subdividing of the larger sample, to reduce it to a convenient size for transmission to the laboratory, requires special consideration as having an important bearing on the maintenance

of the correct ratio of constituents. This may be best shown by the data given in Table XXVII.

Note in this table that Series 1 and 2 are 3-lb. samples taken by subdividing in the same manner the same gross sample of about 30 lb. Each sample was ground to 8 mesh and sized. It will be seen that in Series 1, duplicates *a* and *b* had 16.6 and 13.7 per cent of the 60-mesh size, whereas in Series 2 the duplicates *a* and *b* had 22.5 and 23.1 per cent, respectively. Note,

TABLE XXVII.—ASH VARIATIONS IN DIFFERENT SIZES OBTAINED FROM DUPLICATE SAMPLES

Series	Mesh	Duplicate halves	Per cent of each size	Ash	<i>a</i> and <i>b</i> composited by calculation		
1 ₁	On 20.....	<i>a</i>	41.7	14.11			
		<i>b</i>	48.4	14.00			
1 ₂	Through 20.... On 60.....	<i>a</i>	41.7	15.55		<i>a</i> 16.32	
		<i>b</i>	37.9	15.42		<i>b</i> 15.86	
1 ₃	Through 60....	<i>a</i>	16.6	23.89		Average..... 16.09	
		<i>b</i>	13.7	23.65			
2 ₁	On 20.....	<i>a</i>	29.1	15.91			
		<i>b</i>	25.0	15.68			
2 ₂	Through 20.... On 60.....	<i>a</i>	48.4	16.23			<i>a</i> 17.90
		<i>b</i>	51.9	16.06			<i>b</i> 17.80
2 ₃	Through 60....	<i>a</i>	22.5	24.09			Average..... 17.85
		<i>b</i>	23.1	23.98			

further, the great increase in ash in the fine size as compared with the ash in the coarse material. For example, Series 1 having an average of 14 per cent of ash in the coarse size has an average of 23.75 per cent in the fine portion. A similar increase in ash is seen in the corresponding sizes in Series 2. The ultimate ash average for Series 1 is 16.09 per cent and for Series 2 it is 17.85 per cent. These values vary consistently with the variation in the percentages of fine material in the respective series. On the other hand, the duplicate halves *a* and *b* throughout,

because of their uniformity resulting from the sizing process, show results in the several pairs which check very closely.

The values as presented in the table, therefore, show clearly that in the process of subdividing the gross sample and in the further reduction of the sample as received at the laboratory, great care must be exercised to see that no part of the manipulation is of such a nature as will promote segregation of the constituents.

Riffling.—A riffle, constructed according to the pattern shown in Fig. 65, may be used to advantage after the sample has been reduced by quartering to about 5 lb. At this stage the

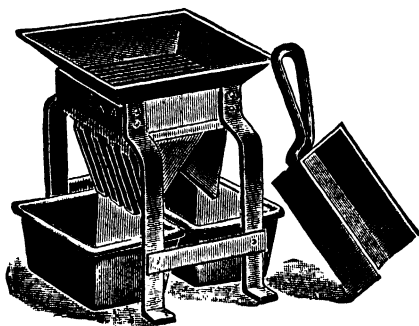

FIG. 65.—Riffle.

sample is ground to $\frac{1}{8}$ -in. size, hence the riffle openings may be $\frac{1}{2}$ in. in width. With this variation in the openings, the riffle as shown in Fig. 65 is substantially the one described in the Ohio Geological Survey, *Bulletin 9*, page 313, 1908.¹

Segregation may occur where least expected; for example, in the use of a riffle, if the material is added from the scoop more rapidly than it can pass through the openings, thereby piling up in the riffle hopper, the material tends to form itself into cone-shaped masses, down the sides of which the particles may flow more readily in one direction than in another, depending on the freedom of the opening. Such conditions promote marked segregation. Riffles with large hoppers and small grid areas are not of good construction. Numerous tests on this point have been

¹ See "Standard Methods" of the American Society for Testing Materials, 1916, p. 552; also, the same volume for sampling details, pp. 544-549.

made.¹ One set only is given here. Sample 1 of Table XXVII, not separated into the various sizes, shows an ash content of 16.09 per cent. The two halves obtained by proper feeding of the riffle gave 16.07 and 16.26 per cent, or a difference of 0.19 per cent. By rapid feeding, sufficient for the material to pile up in the hopper, the two halves gave ash values of 14.35 and 17.87 per cent, respectively, or a difference of 3.52 per cent.

Sampling a Carload.—A car of coal may be sampled to the best advantage in the process of unloading. An occasional half shovelful should be thrown into a proper receptacle so that by the time the car is unloaded approximately 200 lb., evenly distributed throughout the load, will have been taken. This will mean about one-half shovelful for every 10 full scoops. They are best taken in the process of shoveling from the bottom of the car, since the top coal rolls down and mixes fairly evenly with the bottom. It should be kept in mind that in taking a sample there must be obtained the different sizes of coal, fine and coarse, in their proper proportions, from the entire cross-section of the mass, and also an even distribution of the sample lengthwise of the car. Even greater care must be taken to guard against loss of moisture in the process of collecting and in reducing the gross sample for the reason that as a rule the relative humidity outside of the mine is lower and the tendency of the moisture to leave the coal is correspondingly increased.

It has been shown in Table XXVII that the finer particles of a coal mass are higher in ash and hence have a greater specific gravity. They are therefore more likely to separate by gravity from the coarser material. On this account, if a car is to be sampled without unloading, it is necessary to dig well toward the bottom in order to obtain a representative sample. Three trenches should be dug crosswise of the load, one near each end and one near the middle of the car. These trenches should go down nearly to the bottom of the mass and each size be taken as nearly as possible in its proper proportion. Lump and run-of-mine lots are much more difficult to sample than screenings, but it should be noted that screenings may vary greatly, for not infrequently a car is partially loaded from one bin and finished

¹Illinois Coal Mining Investigations (Cooperative agreement), *Bull.* 3, pp. 25-36, 1916.

from another which may be of a different size and composition. After obtaining the gross sample, the methods to be followed are the same as those already given.

Composite Samples.—It is often desirable to composite a number of samples. In this way a single sample may be made to represent a much larger quantity of coal and thus cut down the time and expense involved in procuring the analytical data. In this procedure, however, it must be remembered that even greater care should be exercised in taking the several component samples. The amount of each sample entering into the composite must be in proportion to the mass which it represents, and finally a thorough and positive mixing of the composited mass must be effected before quartering the same down to the usual 5-lb. quantity.

It is convenient to determine the amount of each sample to be taken by employing an aliquot system of weights. For illustration: Suppose we adopt 1 gram to the 100 lb. as the unit which shall enter into the composite. Then a 100,000-lb. car of coal should be represented by 1,000 grams. In compositing, therefore, the total amount of each sample will not be taken, but instead an aliquot proportion which will give to each car lot its due amount. It is preferable to use such a factor as shall utilize the major part of the several 5-lb. samples. In this way the gross composite from 10 cars would aggregate 20 or 30 lb. in weight. It should be coned and quartered until a thoroughly homogeneous mass of about 5 lb. is obtained, as already described. For this procedure it is obvious that the necessary data should accompany the various samples. A ticket inserted in the can before sealing should give the data needed.

A convenient form is as follows:

From.....	Date.....	19..
For.....	(When taken)	
Kind of coal.....		
Car initials.....	Car No.....	
Net weight.....		
Weight taken for composite ¹		
Weight of quarter taken for dust.....		
Weight of dust in quarter taken.....		

¹ Divide the net weight by 2 and place a decimal point after the first figure of the quotient.

Mechanical Sampling.—Numerous attempts have been made to devise a mechanical method for taking samples. While it is possible by such means to eliminate the personal equation, it is difficult to avoid segregation or an uneven distribution of coarse and fine material. These have depended for the most part on the principle of diverting a small portion of the coal from a conveyor.

Grinding the Sample.—In the sample grinder illustrated in Fig. 66 there is an evident advantage that with such a power grinder larger samples may be handled, thus dividing rather

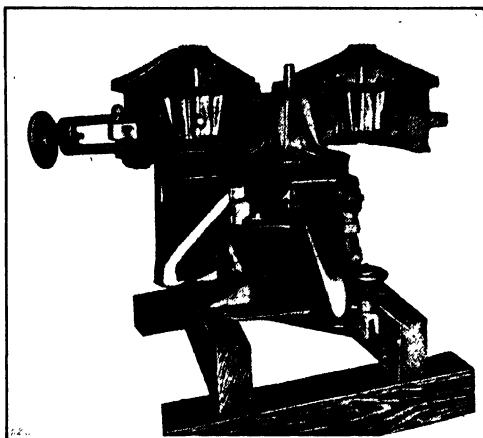

FIG. 66.—Grinder open for cleaning.

than multiplying the errors. The illustration shows the grinder opened for cleaning, at the end of the operation. Both the central grinding cone and the wing stirrer underneath may be lifted out for cleaning the entire grinding and distributing chamber. The sampling feature is so arranged that an aliquot part, approximately 10 per cent, is delivered into the small receptacle in the process of grinding the original mass. In use of such a sample grinder, the facility with which the material may be passed through makes it possible to take much larger initial samples. For example, if occasional shovelfuls are taken, well distributed throughout the unloading of a car in such an amount as to yield say 40 lb. in the aliquot portion, then it is known that approximately a 400-lb. gross sample has been passed through the grinder.

Doubtless the best method for determining the accuracy of the sample delivered by the apparatus is to compare the ash values, water-free basis, as obtained from the small sample with the ash value from the main portion, sampled by carefully quartering down by hand in the usual manner. A number of tests of this sort are shown in Table XXVIII.

TABLE XXVIII.—ACCURACY OF SAMPLE GRINDER BY COMPARISON OF ASH VALUES—DRY BASIS

(Samples *A* and *B* obtained from main portion by quartering and riffing)

Laboratory number	Coal	Ash in small sample as delivered by grinder	<i>A</i> Ash in main portion sampled by quartering and riffing	<i>B</i> Ash in main portion Duplicate of <i>A</i> —opposite quarter
8661	Vermilion Co. Screenings	15.53	15.22	15.72
8664	Vermilion Co. Screenings	14.52	14.52	14.65
8667	Vermilion Co. Screenings	19.19	19.88	19.72
8670	Vermilion Co. Screenings	17.43	17.78	17.58

Another test has been applied as follows: The samples as obtained in the process of grinding 10 gross samples were delivered into a common receptacle in their proper proportions for compositing. Without further mixing, the mass of approximately 40 lb. was poured into the grinder. The accuracy of the small sample thus obtained was determined, as before, by comparison of ash values. The main portion was sampled again by pouring through the mill a second time for a duplicate aliquot delivery. The results are shown in Table XXIX. In both of these tables the agreement between the sample delivered by the mill and the sample obtained from the main portion is very satisfactory, especially when we consider the variations inherent in the processes of analysis for high-ash coals.

Moisture Control.—The further essential in taking and preparing a sample relates to the free moisture present and requires that the changes in moisture content must be under exact control so that at any stage the ratio of the moisture present to the original moisture of the mass may be definitely known.

Where the moisture in the coal as it comes from the mine averages from 10 to 15 per cent, the tendency toward moisture

TABLE XXIX.—ACCURACY OF SAMPLE GRINDER BY COMPARISON OF ASH VALUES—DRY BASIS

(Duplicate samples obtained by second passage of main portion through mill)

Laboratory number	Coal (screenings)	A First aliquot of 10 per cent as delivered	B Second aliquot of main portion
8668	Moultrie County	19.61	19.60
8934	Moultrie County	20.32	20.38
8961	Moultrie County	20.94	21.13
8973	Moultrie County	19.21	19.82
9011	Moultrie County	19.21	19.17
9013	Moultrie County	19.62	19.41
9025	Montgomery County	13.69	13.44
9143	Moultrie County	19.64	19.67
9147	Moultrie County	19.83	20.03
9162	Moultrie County	20.14	20.26
9160	Montgomery County	14.17	13.89
9180	Moultrie County	19.32	18.94
9185	Montgomery County	13.30	13.48
9195	Moultrie County	19.72	19.90
9197	Moultrie County	18.61	19.18
9240	Montgomery County	13.20	12.95
9242	Moultrie County	19.82	19.89
9244	Moultrie County	18.93	18.96
9268	Montgomery County	13.48	13.43

changes is very marked. For example, the process of crushing down the larger sizes affords an opportunity for the escape of moisture. Again, if the coal is spread out on the floor of a hot boiler room or left exposed to currents of air for any length of time, there will be a serious change in the moisture factor. Another practice sometimes followed is that of assembling the various increments of the gross sample in a sack or other receptacle permitting a relatively free transmission of air. Samples kept in this manner for any length of time or shipped in such containers will have a moisture content quite different from the original.

The methods employed, therefore, in collecting and reducing a gross sample must have special reference to this tendency on the part of the free moisture to escape. The work should be done

rapidly in a room at or below the normal temperature and, so far as possible, with the use of closed apparatus which admits of the least possible exchange of the contained air. Precautionary measures of this sort should be made at the very outset. The gross sample, especially, if made up of small increments collected usually over a considerable length of time, should be enclosed in a tight box or clean garbage can having a tightly fitting cover which can be closed and locked against the possibility of change until the time for grinding and reducing.

The reduction of the large sample, by grinding and quartering or by grinding and mechanically delivering an aliquot fraction, is thus secured, having had special regard to conserving the original moisture. The sample, now about 3 lb. in amount, is placed in a galvanized iron can and the can is sealed air-tight by a well-fitting screw cap and rubber gasket. This seal is made further secure by winding electrician's tape around the joint, between the screw cap and the can.

Sampling of Pulverized Fuel.—Samples of pulverized fuel are usually desired for screen analyses for check on the grinding mills. In general, these samples are taken from a moving stream of the finely divided fuel and, because of segregation of the heavy particles from the light, some difficulty has been experienced in obtaining representative samples. Results of screen analyses are not comparable unless the samples are all obtained in the same manner. It is not possible to take samples of pulverized fuel from a unit system in the same manner that samples are taken from the bin system. Data obtained by the Riley Stoker Corporation¹ indicate that a finer sample is obtained by traversing the mill discharge pipe near the mill in a direction parallel to the mill axis than by making the traverse at right angles to the mill axis, because of the coarser coal which is thrown to the outer part of the casing.

For the bin system² not less than 2 kg. of representative powdered coal should be collected as it is being discharged from the pulverizer. This is best accomplished by collecting incre-

¹ Nat. Elec. Light Assoc., *Serial Report of Prime Movers Committee, Pulverized Fuel*, No. 267-95, p. 2.

² Amer. Soc. Testing Materials, *Method D 197-30, "Standard Methods," 1930*, p. 728.

ments of not more than 200 grams at regular intervals by means of a scoop. The increments should be placed in a can of about 8- to 10-liter capacity provided with a tightly fitting cover.

For the unit system¹ the sampling device consists of a 1-in. thin-walled brass tube, bent at one end to a right angle. At the other end, a vacuum-sweeper bag is tightly attached. The sampling tube is inserted into the powdered-coal pipe through a stuffing box in such a manner that the opening of the sampling tube is directed against the stream of coal and air, and permits moving back and forth across the entire diameter of the coal pipe. If the sample must be taken from a horizontal pipe, the sampling tube should be inserted through the top of the coal pipe in such a manner as will permit moving the tube back and forth from top to bottom along the vertical section of the pipe. In collecting the sample, move the tube uniformly along the diameter of the pipe. Sampling should be continued at regular intervals until a gross sample of not less than 5 kg. of coal is collected.

¹Amer. Soc. Testing Materials, Method D 197-30, "Standard Methods," 1930, p. 728.

CHAPTER XXIV

THE PROXIMATE ANALYSIS OF COAL

Introduction.—Coal may be subjected to either the ultimate or proximate method of analysis. In the former, besides the moisture, ash and sulfur factors, a determination is made of the constituent elements comprising the organic substance of the coal; namely, carbon, hydrogen, nitrogen and oxygen.

In the proximate method, besides the moisture, ash and sulfur, there are determined, instead of the elemental substances of the organic part, only volatile matter and fixed carbon. The ultimate analysis furnishes data from which the heat value of the coal can be calculated. The proximate analysis gives the necessary data for judging of the kind and general character of the coal.

The procedure as here outlined for the proximate analysis of coal follows substantially the final report on methods of analysis as adopted by the Joint Committee of the American Chemical Society and the American Society for Testing Materials.¹ The preliminary report of this committee² contains much detail of value relating to sources of error and general conditions to be observed in the procuring of accurate results. The final report is in a much more condensed form and is intended as a guide for everyday procedure in connection with coal contracts and inspection.

Moisture and Nomenclature.—The topic of moisture control has already been referred to, emphasis having been laid upon the fact that at any stage of the processes the exact ratio of the moisture present to the moisture of the original mass must be definitely known. This implies that moisture changes do occur

¹ Report of Committee E-4: *Yearbook*, Am. Soc. Testing Materials, p. 596, June, 1915.

² *Ind. Eng. Chem.*, vol. 5, p. 517, 1913; published also in *Proc. Am. Soc. Testing Materials*, vol. 14, p. 412, 1914.

Indeed three moisture conditions exist and, since under each condition all of the accompanying factors are modified to meet the specific change in moisture, a special designation is applied to the coal for each one of these conditions.

Coal with all of the normal moisture present is designated as coal "as-received." It relates to the moisture at the time of taking the sample. All of the detail of the processes for collecting and reducing the gross sample up to and including the item of sealing and shipping the 5-lb. sample involves the preservation of this initial moisture without loss.

The second moisture status is that wherein the as-received coal has been dried to a point of substantial equilibrium with the moisture of the air, so that in an atmosphere of average humidity it would take on or lose additional moisture very slowly or not at all. In this condition the coal sample is said to be "air-dry." This is the condition to which the chemist must bring the sample in order that the processes of finer grinding and weighing may be carried on without change in the moisture factor. Obviously the amount of moisture lost in passing from the as-received condition to the air-dry condition must be carefully measured. The factor thus determined is designated as the "loss on air drying." By use of it, all of the values obtained from analysis of the coal in the air-dry state may be calculated to the as-received condition.

The third condition recognized is that of "dry" coal. This is sometimes designated as the "oven-dry" or "moisture-free" state. All of the values found for the coal in the air-dry condition may be transferred by calculation and made to apply to the coal as "oven-dry." The necessary factor in this case is the loss of moisture obtained from drying the air-dry sample at or slightly above steam temperature, for instance, 105°C., for 1 hr.

Carelessness in the use of these terms leads to much confusion. The chemist and the engineer are not always in agreement as to their meaning. The results as obtained by chemical analysis upon the air-dry sample are of little use to the engineer, whose basis of reference is to the as-received or to the dry basis. For the purpose of the engineer it is necessary, therefore, to calculate the results which are obtained on the air-dry sample back to the

as-received, and also to the dry basis. These values are the only ones that should be reported. The factors obtained on the air-dry basis are for the chemist only, and have no significance for any one else.

It will be evident at once that throughout all of the handling of a coal sample there must be exact control of the free moisture and knowledge of the amount present at the various stages of reference, in order that calculations may be made from one basis to another.

Moisture Loss in Air Drying.—Spread the as-received, 4-mesh sample to a depth of $\frac{1}{2}$ to $\frac{3}{4}$ in. on a weighed pan about 18 by 18 in. by $1\frac{1}{2}$ in. in depth. Weigh and air dry at room temperature or in a special drying oven through which a current of air is circulated and in which the temperature is maintained at 10 to 15°C. above that of the room. Weigh again after 12 to 24 hr. The moisture content should now be in approximate equilibrium with the moisture of the air, but will vary greatly, depending upon the nature of the coal. It may be indicated by the fact that a continuation of the drying process will not show a loss of more than 0.1 per cent per hour. Note the loss of moisture on air drying and calculate to percentage of the entire sample as received.

Laboratory Sample.—The preceding discussion on sampling related mainly to the taking of the gross sample. Ordinarily it should be about 3 to 5 lb. in amount and sealed in a manner to preclude the possibility of change in moisture content while being transported to the laboratory. The preparation of a working sample for the various analytical processes must be carried out with special reference to the chief considerations which govern the taking of the gross sample. For example, there must be maintained an even distribution of impurities throughout the sample. A certain ratio of size of particles to size of sample must be observed. If the gross sample as it comes to the laboratory is not over 3 lb. in amount, the entire sample should be fine enough to pass a $\frac{1}{4}$ -in. screen. This means that the largest particle will have a dimension not greater than $\frac{3}{16}$ or $\frac{1}{5}$ in. Similarly, the working sample of approximately 60 grams must be sufficiently fine to pass a 60-mesh sieve. With this reduction in size the tendency to segregate is increased and

the opportunity for moisture changes is greatly augmented. This is an especially important feature to keep in mind in working with Illinois coals which have an initial free-moisture factor at the time of breaking out of the seam of from 5 to 15 per cent. These coals also absorb oxygen rapidly, especially when finely divided and at slightly elevated temperatures. This is the chief factor in deterioration and loss of heating value. The freshly prepared sample will be found to give higher calorific values than an old one. The entire air-dried sample immediately after final weighing is passed through a grinder of the coffee-mill type set to grind to about 20-mesh. It is mixed and riffled down to about 500 grams and transferred to a porcelain jar of a ball-mill. The jar should be not over one-third full of pebbles and the coal sufficient in amount to have a partial cushioning effect so the pebbles will not strike too harshly upon the wall of the jar. A measurable increase in ash may result from abrasion of the jar. The coal should be pulverized to 60-mesh, which will be complete for bituminous coals in about $\frac{1}{2}$ hr. The jar should turn at about 60 r.p.m. The pebbles are then separated on a coarse sieve, and the coal mixed and riffled to a laboratory working sample of about 60 grams, all of which should pass a 60-mesh sieve. Instead of a ball-mill the buckboard may also be used for grinding the laboratory sample. In this case a smaller amount, about 100 grams, should be taken.

After grinding to 60-mesh, 50 grams of the coal is placed in a small bottle with rubber stopper from which the samples for analysis are weighed.

It is well to remember that, even under these conditions of storing, changes in the sample occur such as segregation, due to the settling of the heavier particles; oxidation which results in a slight increase of free moisture; and especially if the moisture is high, *i.e.*, above 4 or 5 per cent, a very appreciable change in the iron pyrites from FeS_2 to $\text{FeSO}_4 + 7\text{H}_2\text{O}$.

Moisture in the Laboratory Sample.—Determine the moisture in the 60-mesh working sample by weighing out 1 gram in a glass capsule and drying with the cover off at 104 to 110°C. for 1 hr. Replace the cover, cool in the desiccator and weigh. The loss of weight is the amount of water in the sample.

Total Moisture.—(a) The value for total moisture on the sample “as received” is obtained by combining the loss on air drying with the moisture factor found on the air-dry sample as just described. These two factors cannot be added, of course, until brought to the same basis of reference. Calculate the moisture found in the air-dry sample to the percentage it would be of the original coal, as received, and add to the loss on air drying. This will give the total moisture percentage.

To calculate from the air-dry values to the as-received condition, multiply each percentage for the air-dry state by $(100 - l)$ in which l is the loss on air drying. The moisture factor thus derived plus the loss on air drying equals the total moisture in the as-received coal. This and the other factors calculated as described should equal 100 per cent.

To calculate the percentage values obtained on air-dry coal to the “dry-coal” basis, divide each constituent by $(100 - w)$ in which w is the moisture present in the air-dry sample. The moisture for the “dry” coal is omitted, of course, and the sum of the resulting constituents should total 100 per cent (see special paragraph under Calculations, page 215).

b. Another method whereby the total as-received moisture is obtained directly and which also has certain advantages and is probably in more general use is as follows: Immediately after passing the 5-lb. gross sample through the coffee-mill grinder for reduction to from 10- to 20-mesh size, it is spread out in a shallow pan and by means of a spoon a 60-gram sample is taken from various parts. This is placed without sieving in a rubber-stoppered bottle and labeled “For Total Moisture.” Weigh 5 grams into a shallow aluminum dish with suitable glass cover and heat with the cover off for $1\frac{1}{2}$ hr. at 104 to 110°C. Cover and cool in a desiccator over concentrated sulfuric acid (sp. gr., 1.84). The loss in weight calculated to per cent represents the total moisture of the coal, as received.

The main portion of the sample is air dried in a shallow pan as described under that paragraph but without regard to moisture loss. When the moisture content is reduced to a constant value, the sample is thoroughly mixed and reduced by riffing to about 120 grams. It is then pulverized by any suitable method to 60-mesh and the moisture determined by oven drying at from

104 to 110°C., as described under Moisture in the Laboratory Sample.

Ash.—*a.* Transfer the 1 gram of coal remaining in the glass capsule from the moisture determination to a shallow porcelain ashing dish. Place on a triangle 2 or 3 in. above a Bunsen flame. It can be left in this position without attention for 15 to 20 min., when most of the carbonaceous matter will have burned off. Lower the ashing dish to within $\frac{1}{4}$ or $\frac{1}{2}$ in. of the flame and leave without attention for an equal length of time. Occasional stirring with a platinum or iridium wire will facilitate the oxidation. Finally place the dish in a muffle maintained at a dull- or cherry-red temperature at 700 to 750°C. Ten minutes in the muffle should be ample for burning off the last traces of carbon. If special ashing dishes and a muffle are not available, a porcelain crucible and No. 5 Meker burner may be used but special care should be given to the temperature employed and sufficient time allowed with occasional stirring to insure complete burning out of all carbonaceous matter. Cool in a desiccator and weigh. Subtract the weight of the crucible and compute the weight of the ash to percentage of air-dry coal.

b. It occasionally occurs that coals are met with, having a percentage of CaCO_3 , which makes it advisable in careful work, especially where unit coal values are involved, to modify the usual method for the determination of ash. When the CO_2 value, for example, exceeds 1 per cent, or when the calcite is in excess of about 2 per cent, these modifications should be observed. The reason is obvious. The combination of FeS_2 and CaCO_3 in the process of ashing produce Fe_2O_3 and CaS . The latter, however, slowly oxidizes to CaSO_4 . It is the uncertainty as to the completeness of this change which makes it advisable to alter the procedure for coals of this type. While the dissociation temperature of CaCO_3 is too low to allow ashing the coal without decomposition of the calcite to CaO and CO_2 , it is possible by transforming the CaCO_3 to CaSO_4 , to obtain a compound of sufficient stability to allow complete ashing, without changing its composition.¹ The modified procedure therefore is as follows:

¹ Illinois Coal Mining Investigations (Cooperative agreement), *Bull.* 3, pp. 25-36, 1916.

After the preliminary burning off of the carbon and cooling, the ash is moistened with a few drops of sulfuric acid (diluted 1:1) and, after careful application of heat to avoid spurting, is heated to 700 to 750°C. and retained at that temperature for 3 to 5 min. Cool in a desiccator and weigh. The correction to be applied to the ash as weighed may be calculated as follows: Consider that in the change from CaCO_3 to CaSO_4 there has been a total change in molecular weight of 36, or three times the atomic weight of carbon. Therefore, to restore the weight of ash as determined to what it was in the original coal before ashing, we should subtract three times the equivalent weight of the carbon present as CaCO_3 .

Because of the ease of determining the carbon present in the carbonate form and because the presence of carbonate is irregular as to distribution even in the same mine, it is strongly urged that a determination be made for carbonates, especially on new and unknown samples. This is especially important where corrections are to be made for ash determinations, as in calculations for "unit coal," as also in determinations for *total carbon* by the volumetric method. The method for determining carbonates is given under the latter heading, page 269. Its application in calculations for unit coal is given on page 54.

Volatile Matter. *a. Official Method.*—The official method for determining the volatile matter in coal as indicated by the Joint Committee on Coal Analysis in the *Journal of Industrial and Engineering Chemistry*¹ prescribes the use of a platinum crucible with capsule cover fitting inside of the crucible, that is, telescoping $\frac{1}{8}$ to $\frac{1}{4}$ in., instead of an ordinary cover resting on the upper edge. The crucible with 1 gram of coal is placed in a muffle maintained at 950°C. ($\pm 20^\circ\text{C}.$). A vertical electrically heated muffle is easy of construction and very satisfactory for this work. On account of the variation in pressure and heating value of city gas it is difficult to obtain consistent results with the Bunsen or Meker burner. A muffle heated by gas and maintained at the proper temperature is much to be preferred to heating by the direct flame. On account of the expense of platinum, the use of an illium crucible may be substituted in class work as indicated below.

¹ Vol. 5, p. 522, 1913.

It is to be noted that any method which retards the transmission of heat to the coal will result in a lower indicated amount for volatile matter and a correspondingly higher percentage for fixed carbon. The illium alloy should give the same values as when using platinum. In the absence of a suitable muffle it may be possible to make use of the flame of a larger Meker burner. By means of a thermocouple it should be determined that the flame temperature of the gas used is well above 900°C. and a burner used of sufficient size to completely envelop the illium crucible and capsule cover. This is fairly well accomplished by use of the No. 5 Meker burner. Where porcelain crucibles are the only ones available the discrepancies from the official values are apt to be large. Fairly satisfactory results may be obtained, however, by use of a No. 5 Meker burner and accumulating an advance heat supply as indicated in the next paragraph.

b. Porcelain Crucible Method.—Select a porcelain crucible with well-fitting cover, ignite, with cover, in the flame of a No. 5 Meker burner to a dull-red heat, cool in the desiccator and weigh. Place a nichrome triangle over the burner and over the triangle place an inverted 20-gram assay crucible with the bottom ground off, exposing a hole approximately 1 in. in diameter. When this apparatus is heated to as high a temperature as possible, remove the inverted crucible, put in place the porcelain crucible, with cover on, containing the 1 gram of air-dry coal, and restore at once the prepared assay crucible. Continue the heating for 7 min. and at the end of the period turn off the flame and remove the assay crucible but do not disturb the cover of the porcelain crucible until the same has been reduced below a red heat. Transfer to a desiccator, cool and weigh with the cover. The loss in weight minus the moisture present is the weight of volatile matter.

Fixed Carbon.—The sum of the percentages for moisture (on the air-dry or working sample), ash and volatile matter, subtracted from 100, will leave as a remainder the percentage of fixed carbon in the air-dry coal.

Calculations.—A type of computation is constantly employed in connection with fuel analysis, which, while exceedingly elementary, seems not to have been encountered by the average

student in his public school work. Or possibly these simple arithmetical concepts, once familiar, have been forgotten because of the lack of even occasional contact. It is urged that the student revive his acquaintance with them to the point of genuine familiarity.

The working sample of coal which is used in all of the analytical processes has been brought into approximate equilibrium with the air, so that its content of moisture will not appreciably change during the process of weighing out the amount to be taken for each determination. The preparing of this air-dry sample is therefore for the purpose of securing great accuracy in weighing and is a matter of particular concern to the chemist only. The results obtained on that unusual or specific sample are of use to no one else and should not be reported in that form. They must be calculated either to the dry, that is the moisture-free basis, or to the wet, that is the as-received basis or, more commonly, both sets of values are included in the report.

To transfer values obtained on the air-dry sample to the dry basis, the moisture factor is eliminated and the resulting values total 100 per cent. Each value obtained on the air-dry basis therefore is *divided by 1 minus the content of moisture*.

The values obtained on the air-dry sample contain a moisture factor and total 100 per cent. To transfer them to the as-received basis there is to be restored the moisture lost on air drying. The resulting values, including all the moisture, must total 100 per cent. The new values are computed therefore by *multiplying the air-dry values by 1 minus the loss on air drying*. Note, however, that the sum will not equal 100 per cent unless that process is also applied to the moisture factor of the air-dry material and this value combined with the moisture loss on air drying.

It may be that the moisture loss on air drying has not been obtained but the somewhat simpler method (b) has been followed, of taking a special sample for total moisture. In this case calculate the air-dry values to the dry basis and multiply these values by 1 minus the total moisture found in the as-received sample.

The reasons for these various processes should be clearly evident to the student. A simple formula as above suggested

can then be developed as a working convenience. Note that the general principle is involved in many other connections. For example, the corrected ash as well as the moisture are eliminated in deriving the values for unit coal where the only item wanted is the heat value to be transferred from the as-received to the unit-coal basis.

CHAPTER XXV

THE CALORIMETRY OF FUELS—THE OXYGEN BOMB CALORIMETER

Definitions.—Heat values are expressed in various ways. A *British thermal unit* (B.t.u.) is the amount of heat required to raise one pound of water at its maximum density, 40°F., through one degree Fahrenheit. A calorie is the amount of heat required to raise one gram of water at 15°C. through one degree Centigrade. The large *Calorie* is also used, which represents the amount of heat required to raise one kilogram of water through one degree Centigrade. But these abstract definitions are of use only as indicating the actual value of these units, and the relation one unit bears to the other. For example, since the Centigrade degree is $\frac{9}{5}$ or 1.8 times the Fahrenheit degree, and the kilogram is 2.2046 times as great as one pound, it follows that one large Calorie is the equivalent in Fahrenheit units of 1.8 times 2.2046, or 3.968 B.t.u. Hence:

$$1 \text{ Cal.} = 3.968 \text{ B.t.u.}$$

$$1 \text{ B.t.u.} = 0.252 \text{ Cal.}$$

It will be evident at once that the heat units as thus defined are without significance in expressing the calorific value of a combustible, unless we indicate the amount of material for which the unit stands. For example: In burning a pure chemical element or compound we may make record of the heat of oxidation as being so many calories per gram, or so many calories referred to some other amount as the gram-molecule or the atomic weight in grams. The calorific value for the element, hydrogen (H_2), might be given as 68,360 cal., which means that a gram-molecule or 2 grams of hydrogen (H_2) will liberate 68,360 cal. when burned to water; hence the value per gram would be 34,180 cal.

Again the calorific value for carbon may be given as 96,960 cal., which means that a gram-molecule or 12 grams of carbon

will liberate 96,960 cal. when burned to carbon dioxide; hence the value per gram would be 8,080 cal.

Obviously in the case of substances of variable or indefinite composition, such as foods, wood, coal, coke, tar, petroleum and solid or liquid fuels of every description, the unit of reference must be agreed upon, and the gram is commonly used; hence the expression, *gram-calorie*, which means the rise in temperature imparted to one gram of water by the combustion of one gram of substance.

Similarly the *kilo-calorie*, which is the heat imparted by one kilogram of substance to one kilogram of water, would have the same numerical value as a gram-calorie because any weight of a given substance burned in a manner to impart its heat to an equivalent weight of water will produce the same rise in temperature.

This brings us directly to another very important relationship. The British thermal unit refers to the rise in temperature of a pound of water and just as in the gram-calorie or kilo-calorie, the weight of combustible adopted is equivalent to the weight of water used as the basis of measurement, so in the same manner for the British thermal unit, one pound of combustible is considered as imparting its heat to one pound of water. Here again the numerical value is the same as the gram-calorie or the kilo-calorie, provided of course the thermometer readings are on the same scale. This fortunately results in a very simple relationship between calories and B.t.u., being that of the relation between the Centigrade and Fahrenheit thermometers. Thus a fuel calorie is $\frac{9}{5}$ or 1.8 times as large as a British thermal unit. Hence to change Calories per kilogram to B.t.u. per pound:

$$\text{Calories} \times 1.8 = \text{B.t.u.}$$

This relationship, therefore, applies to Continental as well as English and American values, so that the transfer from calories to B.t.u. is simple and universally applicable for all fuels of the solid or liquid type. The matter is quite different, however, in the case of gaseous fuels where the unit quantity of reference is not the same. For example: The B.t.u. value of a cubic foot of gas must be divided by 3.968 to find the equivalent in Calories per cubic foot, and since there are 35.314 cu. ft.

in 1 cu. meter, Calories per cubic foot $\times 35.314$ = Calories per cubic meter.

The following expressions therefore represent the methods involved in passing from one type of gas values to another:

$$\frac{\text{B.t.u. per cu. ft.}}{3.968} = \text{Cal. per cu. ft.}$$

$$\text{Cal. per cu.ft.} \times 35.314 = \text{Cal. per cu.m.}$$

$$\text{B.t.u. per cu.ft.} \times 8.9 = \text{Cal. per cu.m.}$$

Heat Values by Calculation.—Heat values may be determined from the ultimate analysis by Dulong's formula, which assumes that the heat comes from the combustion of carbon, hydrogen and sulfur. The usual values for these constituents are:

$$\text{Carbon} = 8,080 \text{ Cal. or } 14,544 \text{ B.t.u.}$$

$$\text{Hydrogen} = 34,500 \text{ Cal. or } 62,100 \text{ B.t.u.}$$

$$\text{Sulfur} = 2,500 \text{ Cal. or } 4,500 \text{ B.t.u.}$$

Expressed in the latter set of values, therefore, Dulong's formula becomes

$$14,544C + 62,100\left(H - \frac{O}{8}\right) + 4,500S = \text{B.t.u.}$$

In this formula the expression $\left(H - \frac{O}{8}\right)$ represents what is termed the available hydrogen, that is, the amount left after subtracting the equivalent hydrogen needed to unite with the oxygen present to form water, $\frac{2}{16}$ or $\frac{1}{8}O$.

Presumably such calculated values would be in close agreement with indicated values by means of a carefully operated instrument. This is true for coals from certain regions but not for others. The divergence is more pronounced in coals of the Illinois region than in the coals of the eastern United States. In view of the possible presence of calcium carbonate and the consequent error in the ash determination for many Illinois coals, it is evident that a direct variable in such cases enters into the value for oxygen and consequently for the available hydrogen, which would thereby result in a discrepancy between the indicated and the calculated calorific values. Moreover, a high percentage of oxygen in combination evidently may be responsible for variations of quite a different character, as for example a

different distribution of such oxygen in a manner not altogether correctly covered by the expression $O/8$ or in the ultimate form of water. There seem to be therefore numerous reasons why a calculated calorific value by use of Dulong's formula is of little value for coals of this type.¹

The Berthier Test.—The Berthier test is based on the property of carbon to reduce the oxide of lead at a red heat. The higher the percentage of combustible present the larger the button. One gram of coal is mixed with 60 grams of litharge and heated to redness in a crucible. The weight of the button thus obtained is multiplied by 421. The product represents theoretically the reducing power of the carbon in terms of B.t.u. It should be increased by about the value of the available hydrogen present. In Illinois coals this does not vary widely from 3.5 per cent, making necessary the addition of a constant of about 2,000 B.t.u. The results thus obtained may vary from the truth by 300 to 800 units or from 3 to 8 per cent. The method has historical rather than practical interest.

Lewis Thompson Calorimeter.—This is a bell-shaped receptacle for submerging in water and containing within the bell a cartridge having a mixture of 2 grams of coal, with 22 grams of a mixture of 3 parts potassium nitrate and 1 part potassium chlorate.² According to Schorer-Kestner³ this apparatus normally gives results that are in error by about 15 per cent. This apparatus also dates back to a time when a mere approximation to the correct values was all that seemed to be demanded by fuel users. At the present time a degree of exactness is required which was impossible with either of the methods just described.

Types of Oxygen Calorimeters.—There are two types of calorimeters using oxygen as a medium for carrying on the combustion, viz., those in which the oxygen is maintained at atmospheric pressure and those using oxygen under 25 to 30 atmospheres. The first condition is referred to as that of constant pressure, and the second as that of constant volume.

¹ PARR, S. W., Ill. State Geol. Survey, *Yearbook*, p. 236, 1909; also PORTER and OVITZ, U. S. Bur. Mines, *Bull.* 1, p. 28-29, 1910.

² For details of the apparatus see "Fuel, Water and Gas Analysis," by Kershaw.

³ *Jour. Soc. Chem. Ind.*, vol. 7, pp. 868-869, 1888.

Of the first type, the best known perhaps are Fischer's, Carpenter's, W. Thompson's, etc., which conduct a current of oxygen into a chamber containing the fuel. The chief disadvantage results from imperfect combustion, especially with high-ash coals, due to fusion of the ash with consequent enclosure and protection of the carbonaceous matter from further oxidation.

The Parr Oxygen Bomb Calorimeter.—The use of oxygen under pressure in a closed chamber for bringing about the combustion of substances was first devised by Berthelot in 1881 and further developed in the way of cheapened and improved apparatus by Mahler in 1892.¹ While the principle of operation remains the same, investigations have further varied the details as well as the material of construction. One of the necessary conditions is the avoidance of secondary reactions involving the oxidation and dissolution of the material of which the bomb is made.

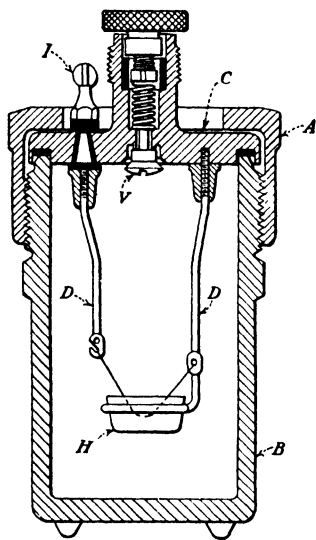

FIG. 67.—Illium oxygen bomb.

In the instrument here described the bomb (Fig. 67) is constructed of an alloy which resists the action of the nitric and sulfuric acids formed as a result of the combustion processes, thus avoiding the necessity of a gold or platinum lining. The metal employed is the Illium alloy. Essential parts of the bomb are:

- The cylinder or bomb proper, *B*.
- The cover, *C*, held in place by
- The screw cap *A*.
- The supporting rods *D* for the
- Fuel tray *H*, being also the electric terminals for
- The fuse wire.

The fuse wire is No. 34 B. & S. gage and may be of pure iron, though a special wire more resistant to oxidation at a red heat is

¹ See Chapter IV on Calorimetry in America, p. 32.

preferred. The latter type of wire is supplied with the instrument. The fuse is operated by an ordinary lighting circuit reduced in voltage so that arcing within the bomb may be avoided.

The fuel tray or capsule is made of illium alloy so that it is immune to chemical action. It is of sufficient size to avoid the necessity of compressing the fuel into a tablet, although some substances are better burned in pellet form. The fuel trays supplied with the instrument are 1 in. in diameter by $\frac{1}{2}$ in. deep.

Heat Values by Oxygen Bomb Calorimeter. *Loading and Attaching Fuse.*—For coal, 1 gram of the air-dry sample ground to pass a 60-mesh sieve is transferred to the capsule *H*. Attach 10 cm. of the fuse wire to the terminals in the form of a somewhat narrow U-shaped loop, taking care that the wire does not make contact with the capsule. For sugar or other material which is difficult to ignite, coil the wire into a small spiral so that a better contact is made than can be assured with the simple loop. Benzoic acid and naphthalene are easy to ignite without the spiral. In the case of naphthalene, to insure against loss of the charge upon igniting, it is well to heat approximately 1 gram in the capsule to the point of incipient fusion and then obtain the accurate weight. The cake-like mass will readily ignite if the wire loop simply touches the surface. Loss by volatilization or spurting is thus avoided. Benzoic acid is now obtainable in pellet form, thus facilitating the use of this excellent standardizing agent.

Closing and Filling the Bomb.—Add about 1 cc. of water to the bomb and wet freely the upper edge which comes in contact with the gasket. It is well also to moisten the gasket before loading the capsule. Then, with the capsule and coal properly located in the support and the ignition wire suitably adjusted, put the cover in place and fasten by means of the screw cap as shown in Fig. 68. The bomb is held in the octagon socket while the wrench is applied. The cover is screwed down firmly and solidly, though extreme force in setting up is not necessary.

The standard method advises the use of oxygen made from the liquefaction of air because of the possibility of traces of hydrogen being present in oxygen derived from the electrolysis of water.

For filling with oxygen, connection is made with the flexible copper tubing, see Fig. 68, and oxygen is admitted until a pressure of 25 to 30 atmospheres (375 to 450 lb. per square inch) is indicated. In admitting the oxygen, the needle valve between the pressure gage and the oxygen tank is opened, at first very slightly, to avoid a sudden rush of gas. After a sufficient amount has been admitted, close the needle valve and open the relief valve below the gage in order to release the oxygen under pressure

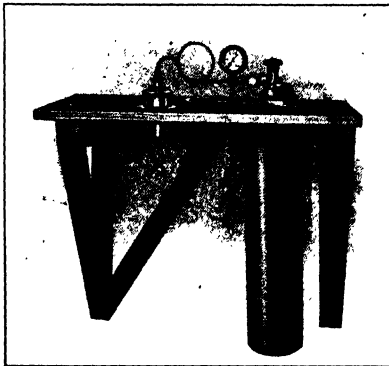

FIG. 68.—Method of filling oxygen bomb with oxygen.

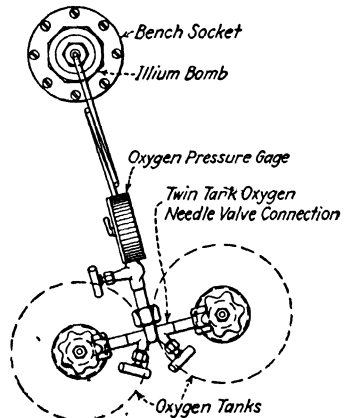

FIG. 69.—Arrangement of twin-cylinder oxygen valve.

in the tube and connections. The check valve *V* (Fig. 67) automatically closes and retains the oxygen at the desired pressure. To give additional tightness to the valve, the thumb nut is put in place and turned down with the fingers only. Do not use a wrench for this purpose. The thumb nut thus screwed in place serves also as a good handle or knob for lifting the bomb and transferring it to the calorimeter.

The Twin-cylinder Oxygen Valve for Economy.—Where it is desired to eliminate wastage of the oxygen supply, an installation is available as shown in Fig. 69. By means of this double needle valve, a cylinder of oxygen may be used to practical exhaustion before removal, whereas in a single-cylinder installation the cylinder must be replaced when its pressure has fallen to 25 atmospheres. In operating the twin-cylinder valve, oxygen from the low-pressure cylinder is first discharged into the bomb

to the limit of its pressure. That cylinder is then shut off and the valve to the high-pressure cylinder opened to complete filling the bomb to the desired amount—25 to 30 atmospheres.

Assembly and Ignition.—The calorimeter should be placed on a good firm desk in a room where fluctuations of temperature may be avoided. The general arrangement of parts is shown in Fig.

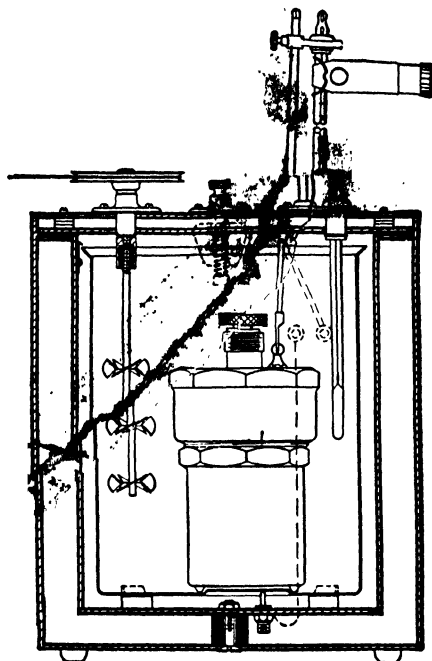

FIG. 70.—Details of Parr oxygen bomb calorimeter.

70. The outside of the can should be dry and no water should be allowed to spill over into the air spaces of the insulating vessels. The bomb is placed a little to one side of the center of the oval can, thus leaving space at one axis of the oval for a stirrer and at the other for a thermometer.

Transfer the bomb carefully without jarring to the can which has been placed in position in the calorimeter. Make the connection with the electrical terminal and add 2,000 grams of water, preferably distilled. The temperature of the water should be

1 or 2°C. below that of the room. The motor is adjusted so as to give the turbine pulley a speed of 150 to 250 r.p.m., rotating clockwise. A uniform speed throughout the determination is desirable.

By use of the telescope readings of the thermometer for the preliminary period are taken at one-minute intervals for 5 min. At the fifth reading the electric circuit for a second, or not to exceed 2 seconds, is broken. The combustion of the sample should be indicated by a rise of the mercury in the thermometer which becomes rapid after 20 seconds. The combustion period extends for 15 min. and terminates when the maximum temperature is reached. The rate of change has become constant during the combustion period. Readings are taken at one-minute intervals for 5 min.

The temperature readings for these three periods furnish the basis for determining the temperature change due to radiation.¹

Dismantling.—After complete readings the apparatus is dismantled by removing the bomb from the insulating jacket and placing it in the holder provided to guard against breaking the thermometer. Transfer the bomb to the octagon holder and release the oxygen from the bomb by unscrewing the thumb nut one-half turn and pressing down on the valve. Do not try to remove the screw cap until after the pressure has been released.

Upon opening the bomb, if any unburned carbon is present the determination should be rejected.

Radiation.—The system containing the bomb and a measured quantity of water is operated at a starting temperature slightly below that of the room and at a final temperature slightly above that of the room, preferably less than 1°F.

A gain or loss of heat will result, due to radiation. This may be corrected for in a very accurate manner, after uniformity has been established, by taking the thermometer readings each minute for the three periods as just described. The correction is the algebraic sum of these plus and minus quantities, and the amount of each quantity is derived from the rate of gain, r_1 , or loss, r_2 , for the two periods, preliminary and final. The exact

¹ See Report of Committee on Methods of Coal Analysis: *Ind. Eng. Chem.*, vol. 5, p. 517, 1913; also U. S. Bur. Standards, *Circ.* 11, 1904.

point for applying the plus and minus values is important, and various formulas are employed in arriving at the final correction. The one here set forth is taken directly from the *Report* of the Joint Committee on Coal Analysis of the American Society for Testing Materials, and the American Chemical Society, published first as a "Tentative Standard" by the A.S.T.M., in June, 1915, and reproduced in final form in the A.S.T.M. book of Standards for 1929.

Radiation Corrections.—The method adopted as standard is based on the observation of Dr. H. C. Dickinson, of the U. S. Bureau of Standards, that the period of transition, from the plus, or lower, to the minus, or higher, heat range is at that period of time when the temperature rise has reached 60 per cent of the total. These factors are then derived and incorporated as follows:

Rate:

The rate, that is, the temperature rise per minute, for the 5-min. preliminary period, is designated. r_1

The rate, that is, the temperature drop per minute, for the final 5-min. period of uniform change is designated. r_2

Observations:

Time of ignition is noted. (a)

Time for 60 per cent of total rise. (b)

Time of uniform rise or final reading. (c)

Computation:

Multiply the rate r_1 by the time from a to b , thus,

$$r_1 \times (b - a) = \text{correction to be added to thermometer reading at } (a)$$

Multiply the rate r_2 by the time from b to c , thus

$$r_2 \times (c - b) = \text{correction to be added to thermometer reading at } (c)$$

Assuming that the thermometer corrections as indicated on the certificate have been made, the necessary radiation corrections are computed as above. Their application, however, must be properly made. It is important to know the transition point (b) where 60 per cent of the total rise in temperature has occurred. In arriving at this point it is only necessary to take readings at 30, 45, 60 and, possibly, 75 sec. after firing. Having obtained the total rise, 60 per cent of that amount, changed to read in minutes and hundredths of a minute, will give the point (b) which should be changed back from minutes and hundredths to read again in minutes and seconds.

Corrections and Calculations.—Preliminary corrections are made (A) on the thermometer readings to account for errors of the thermometer, and (B) for gain or loss due to heat leakage or radiation, as follows:

A. Corrections for Thermometer:

Apply the corrections as indicated on the thermometer certificate for the initial (*a*) and final (*c*) readings.

B. Correction for Radiation:

Multiply the rate r_1 by the time ($b - a$) in minutes and tenths of a minute and add the product to the corrected temperature reading at time (*a*).

Multiply the rate r_2 by the time ($c - b$) and add the product if the temperature was falling (or subtract if the temperature was rising) during the final period, to the corrected temperature reading at time (*c*).

The difference of the two readings, each corrected first for thermometer-scale variations, and second for radiation gain or loss, gives the total corrected rise in temperature.¹

C. Total Thermal Units:

Multiply the total corrected rise in temperature by the total water equivalent of the instrument, which gives the uncorrected determined heat value. The total water equivalent is determined on each instrument experimentally by the combustion of a definite amount of a material of a known heat of combustion. Substances recommended for this purpose are listed under Standardization on page 232. If the thermometer scale is in Centigrade, the result is in calories; if Fahrenheit, the result is in British thermal units.

Either result would represent the total heat of combustion which a given weight of the fuel would impart to an equivalent weight of water, if it were not for certain increments of heat

¹ If the temperature was falling at the time (*a*), then the system is losing instead of gaining heat, and the correction is minus instead of plus, a reduction of the subtrahend operating as a plus correction. Similarly, if the temperature is rising at the time (*c*), the system is gaining heat and the correction for the period ($c - b$) should be minus instead of plus, but if, as normally would be the case, the temperature at time (*c*) is falling, the system is losing heat and the correction should be plus to compensate for the loss. The operator may prefer to take the algebraic sum of the radiation corrections for periods (*a*) and (*c*) and add to or subtract from the difference between the corrected maximum and minimum readings of the thermometer. The ultimate corrected rise by either method should, of course, be the same.

which do not belong to the combustion process and for which corrections can most conveniently be made in terms of heat units as follows:

Thermal Unit Corrections:

D. Correction for Fuse Wire:

Subtract from the total calories under (C) the equivalent in calories derived from the amount of wire burned.

The coal in the bomb is ignited by a fuse wire, No. 34, B. & S. gage, and 10 cm. in length. The amount of wire taking part in the combustion is determined with sufficient accuracy by subtracting the length of the unburned portion from the original length of 10 cm. The weight of the wire is approximately 0.0018 gram per centimeter of length, and with a combustion value of 1,600 cal. per gram the correction for fuse wire will be 2.8 cal. per centimeter of wire burned.

E. Correction for Acids:

Because of the use of pure oxygen at a high pressure and temperature, certain reactions take place which do not occur in the ordinary process of combustion. For example, a small amount of residual air present upon closing the instrument has free nitrogen which, under the conditions of combustion, is partially oxidized to N_2O_5 and, with the moisture present in the bomb, becomes HNO_3 . Similarly, the nitrogen of the coal burns to a greater or less extent to HNO_3 . The sulfur in the coal which under ordinary conditions of combustion burns to SO_2 , in the calorimeter burns to SO_3 or, with the moisture present, to H_2SO_4 . These two highly corroding acids make it necessary to protect the interior surface of the bomb. This is accomplished by use of an enamel lining, by a spun lining of gold or platinum, or by constructing the bomb of an acid-resisting alloy equivalent in that respect to gold or platinum. Where such a precaution is disregarded as, for example, in the enamel type of protection, when the enamel becomes cracked and scaled off, or if a lining of spun metal, such as nickel is employed, the solvent property of the acids becomes active. There are two sources of error which result from such conditions—one is the heat of solution resulting from the chemical action. This, of course, should not

be credited to the heat of combustion of the coal. It would be relatively small in amount, probably not exceeding 5 to 10 cal. The other is the masking of the amount of free acid which thus escapes measurement and would be uncorrected for. In high-sulfur coals of the Illinois type the error from this source may be of considerable moment, frequently equaling or even exceeding 100 cal.

The amount of free acid in the bomb washings is first determined by means of a standard solution of Na_2CO_3 made up of such a strength that each cubic centimeter represents 1 cal. The heat of formation for N_2O_5 *aqua* is 1,035 cal. per gram of nitrogen. The reaction for neutralization is:

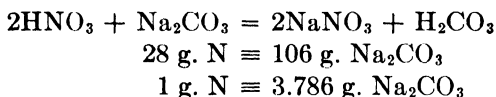

That is, 1 gram N burning to HNO_3 and representing 1,035 cal., requires 3.786 grams Na_2CO_3 . One calorie requires 0.003658 gram of Na_2CO_3 or 3.658 grams per liter, in which 1 cc. would represent 1 cal.

In the calculation thus far it has been assumed that all of the acid present was HNO_3 . The H_2SO_4 must also be taken into account.

When sulfur burns to SO_3 *aqua*, it develops approximately 4,450 cal. per gram of S. In ordinary combustion the burning to SO_2 generates only 2,250 cal. per gram. The excess heat resulting from conditions within the bomb would be represented by $4,450 - 2,250 = 2,200$ cal. per gram of S. But the titration for 1 gram of N as HNO_3 would represent only $\frac{7}{8}$ gram of S as H_2SO_4 . This is evident from the ratio:

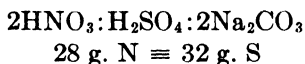

Hence the titration as HNO_3 for H_2SO_4 would be only $\frac{7}{8}$ of the heat to be credited to the sulfur per gram. This means that $\frac{7}{8}$ of the 1,035 cal. or 900 cal. per gram of sulfur have been corrected for. Hence $2,200 - 900$, or 1,300, would represent the additional correction required for 1 gram of sulfur, or 13 cal.

per 0.01 gram of sulfur, equivalent to 13 cal. addition for each per cent of sulfur present in the coal.

It is at once obvious that the acid correction is a matter of some moment. Illinois coals having from 3 to 5 per cent of sulfur will show a titration of from 35 to 50 cc. of the standard alkali representing that number of calories. A coal having 4 per cent of sulfur would have that correction augmented by $4 \times 13 = 52$ cal., or a correction on this account of from 85 to 125 cal. to be subtracted from the indicated heat.

In the above considerations all of the sulfur present is supposed to be in the form of organic sulfur, or FeS_2 , and to burn to H_2SO_4 . Badly-weathered coal may have an appreciable amount of the FeS_2 weathered to $\text{Fe}_2(\text{SO}_4)_3$, but in the open bins this will be practically eliminated by leaching.

For complete combustion to H_2SO_4 in the bomb it is also well to note that sufficient nitrogen must be present to furnish a proper amount of N_2O_5 as catalyzer for the sulfur.¹

The correction in calories for the acids formed, therefore, in addition to the correction for fuse wire, is subtracted from the total observed calories as derived under (C) on page 228.

Finally note that the total indicated heat as corrected for nitric acid, sulfuric acid and fuse wire refers to a quantity of fuel represented by the weight of the charge taken. If this weight were exactly 1 gram, no further computation is necessary. If the weight taken varied from 1 gram, the indicated calories as above derived must be divided at the end of the computation by the weight of the fuel taken.

Note especially also that if a thermometer with the Fahrenheit scale is used, the values are in B.t.u., and the corrections for acid and fuse wire must be changed to correspond. In this case, it will be simpler to make up the standard Na_2CO_3 solution by using 2.032 grams per liter and increasing the titration factor by 23 times the percentage of sulfur. The wire factor also should be taken as five units per centimeter of length. Calculations from these values will then all be in B.t.u. which are subtracted from the total indicated B.t.u. to cover the corrections involved.

¹ *Ind. Eng. Chem.*, vol. 16, p. 812, 1924; also BRADLEY, M. J., CORBIN, R. M., and FLOYD, T. W., The oxygen bomb method for sulfur determinations: *Ind. Eng. Chem.*, vol. 18, p. 583, 1926.

Sulfur Determination.—The correction for sulfuric acid requires that a determination of sulfur be at hand. Percentage of sulfur present in the sample is most conveniently obtained as follows:

Wash the bomb thoroughly with hot distilled water and titrate the washings with a standard solution of sodium carbonate, as described under (*E*) Corrections for Acids. The determination of sulfur may now be made from the titrated washings by acidifying slightly with HCl and following the usual procedure of either the gravimetric or turbidimetric method.

Standardization.—To standardize the instrument make a combustion using a standard substance of known heat value, such as pure benzoic acid. Add to the accepted heat value of the quantity taken, say, 1 gram, the heat due to the combustion of the wire and the nitric acid formed. Divide the heat value thus represented by the temperature rise corrected in the usual manner. The quotient represents the total water equivalent, made up to the actual grams of water employed, or 2,000 plus the equivalent in water of the metal parts, etc., of the apparatus. The substances most commonly used with the values recognized by the U. S. Bureau of Standards are:

Benzoic acid.....	6,320 cal. per gram
Naphthalene.....	9,622 cal. per gram
Cane sugar.....	3,949 cal. per gram

Variations from these values due to impurities may still permit of the substances being used, provided the values themselves have been carefully determined under properly standardized conditions. Because of its availability in pure form and somewhat simpler procedure, benzoic acid is preferred by many users as a standardizing material. It is advisable to compress it into pellets before weighing the sample. This is readily accomplished by use of a pellet press.

Example of Computation

Laboratory No. 7988

Weight of coal burned.....	0.79 gram	
Sulfur in coal.....	4.31 per cent	
Ash in coal.....	12.0 per cent	Room temperature. 78°F.
Moisture, air-dry.....	3.5 per cent	Water equivalent.. 2416.00
Moisture, as-received.....	9.0 per cent	

Readings			
Time		Temp.	
Hr.	Min.	Sec.	°F.
2-11.	00	...	75.725
	12.00	...	75.738
	13.00	...	75.745
	14.00	...	75.750
	15.00	...	75.754
(a)	16.00	...	75.758 (fired)
(b)	17.15	...	78.424
(c)	21.00	...	80.200
	22.00	...	80.198
	23.00	...	80.195
	24.00	...	80.188
	25.00	...	80.183
	2-26.00	...	80.179 (final)

Corrected Temperature:	
Initial, 75.759	Final, 80.201
Computations for Radiation:	
$r_1 = \frac{0.033}{5} = 0.0066^\circ$ per minute	
$(b - a) = 1.25$ min.	
Corrected initial = 75.759	
+ $(0.0066 \times 1.25) = 75.767$	
$r_2 = \frac{0.021}{5} = 0.004^\circ$ per minute	
Corrected final = $80.201 + (0.004 \times 3.75) = 80.216$	
Corrected total rise = $80.216 - 75.767 = 4.449$	
Total B.t.u. = $2416.0 \times 4.449 = 10,749$	
Acidity titration.....	50
Correction for wire.....	11
Correction for sulfur.....	79
	140
B.t.u. for 0.79 lb. coal	= 10,609
B.t.u. per pound coal	= 13,429
Calories per kilogram	= 7,460

It is to be noted that the thermal values obtained are on the air-dry sample. For conversion to the as-received, dry or unit-coal values see discussion under Calculations, page 215.

Gasoline and Volatile Distillates.—In order to obtain an accurate weight of the highly volatile fuels a thin-walled glass container should be made use of. Bulbs such as in Fig. 71 may be readily blown from a piece of soft-glass capillary tubing or a larger tubing drawn out to a capillary. While the glass is still soft, or by softening in the flame, make a small flat spot on one side of the bulb. Make an accurate weighing of the bulb with the capillary end open. It is filled with the liquid by alternately warming and cooling, having the open end of the capillary dipping

into the sample during the cooling process. In this manner the desired amount of liquid is drawn into the bulb. The capillary is sealed in the flame and an accurate weight obtained. Place the bulb in the bottom of a capsule supported on the terminal loop and wrap the fuse wire two or three times around the capillary stem near the bulb. Attach the ends of the fuse wire to the terminals, being careful that the wire does not come in contact with the metal capsule.

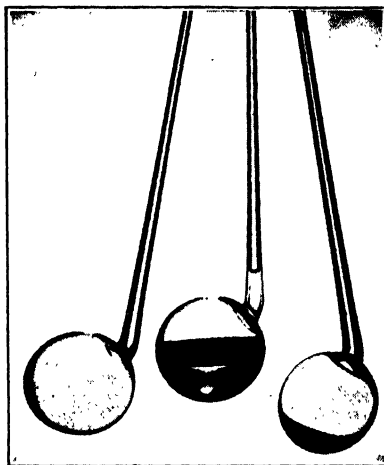

FIG. 71.—Glass bulbs for volatile substances in oxygen bomb calorimeter.

Assemble the cover and screw cap in place and fill with oxygen as usual. The bulb will collapse and liberate the liquid as vapor, ready for ignition when the fuse wire is heated. Sulfur is not likely to be present, and the nitric acid formed will be very small in amount. However, a titration should be made and the correction applied as for nitric acid only.

Petroleum Oils and Residues.—In the case of the heavier or non-volatile oils, the oil may be weighed directly in the capsule or crucible. The capsule and oil are placed in the ring of the supporting terminal and the fuse wire attached with the loop dipping slightly in the oil. The terminals should not be in the path of the flame as it emerges from the capsule. The intense heat of the flame may fuse the terminals. They may be separated properly by bending.

Assemble the bomb and fill with oxygen as usual. Titrate the bomb washings after combustion with standard alkali and make the correction for both acids as in the case of coals. This will of course necessitate the determination of the sulfur present, either gravimetrically or by means of the turbidimeter.

Notes.—*a.* For anthracite and low-volatile coal, a thin pad of asbestos felt should be formed on the inside of the capsule. Take a small amount of asbestos pulp, squeeze out the water and form a felt on the bottom and sides of the capsule, then dry and ignite. This will prevent the lowering of the temperature below the ignition point before combustion is complete.

b. To insure against loss of oxygen through leakage, keep the needle valve between the gage and the oxygen cylinder closed when not drawing out oxygen. For filling the bomb, open the needle valve gradually, regulating the flow by noting the gage indicator. Quick filling will displace the charge.

c. Do not attempt to displace the air in the bomb with oxygen before filling. A certain amount of nitrogen is necessary for the complete oxidation of the sulfur.

Gross and Net Values.—In all of the calorimetric considerations thus far, the results as computed give the gross values—that is, with the products of combustion reduced in temperature to approximately that of the surrounding air, 20 to 35°C. This means that the water formed in the reactions has given up to the system its latent heat of vaporization. The weight of water is hydrogen times 9, and the weight of water times 580 represents the latent heat of vaporization in calories to be subtracted from the observed calories. The remainder is the net heat value.

There is not a little disagreement as to which value, the gross or net, is the more important. In ordinary steam-generating installations, where the flue gases are delivered above the point of condensation, the net values would seem to be required. The engineer, however, in developing his heat balance, takes into account the heat of vaporization of all the moisture, whether free or formed in the reactions, and it is simpler, therefore, to change all such heat to the total or gross heat of the coal. It is desirable on this account that he be furnished the hydrogen factor as one of the constituents of the chemical analysis. This requires an ultimate analysis of the coal. A simplified procedure, however, which is described later, can be used for this purpose.

The Parr Adiabatic Oxygen Bomb Calorimeter.—In calorimeters of the usual type having jacketing walls of bakelite or

other insulating material, there is a heat interchange between the interior of the instrument and the surrounding atmosphere. Although an insulating construction of the most effective type may be employed, there yet remains the necessity of taking heat losses into consideration and of making the necessary corrections

for radiation, if a high degree of accuracy is to be secured. While the procedure for arriving at these corrections has been thoroughly worked out, and exceedingly accurate results may be obtained, the method nevertheless requires some degree of skill and care in manipulation. Therefore, the

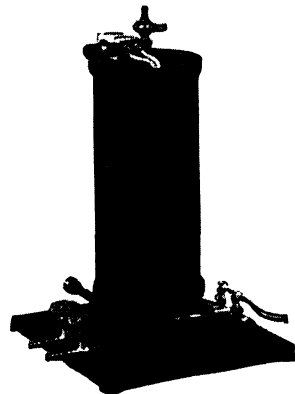
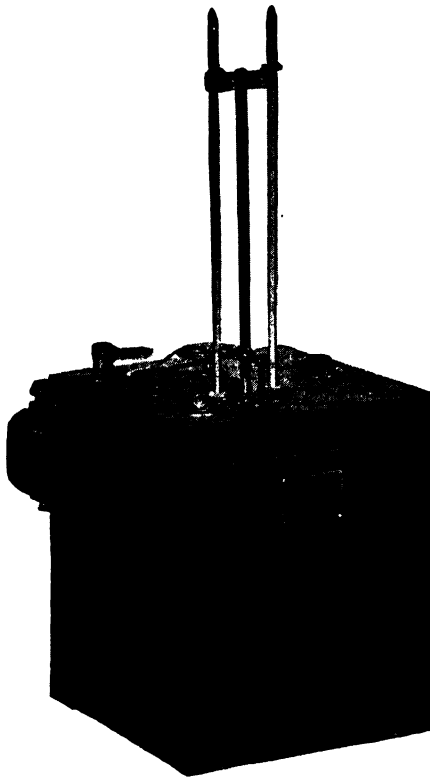

FIG. 72.—A calorimeter of the adiabatic type. FIG. 73.—Water heater for adiabatic calorimeter.

advantages can readily be appreciated in an instrument so constructed as to secure adiabatic conditions within the apparatus, thus avoiding heat leakage and the consequent necessity of corrections. Such an instrument is shown in Figs. 72 and 74.

The interior of the instrument or calorimeter proper is completely surrounded by a jacket through which water is circulated

under close temperature control. Therefore, by maintaining the jacket at a temperature corresponding with that of the interior instrument, all heat losses due to radiation are eliminated. In the cross-section of the apparatus as shown in Fig. 74, the oval bucket, *H*, holds the bomb which is properly located as already described on page 225. It also holds the measured quantity of water, 2,000 grams, the stirrer, *F* and the thermometer. The bucket is located within a casing, *I*, also

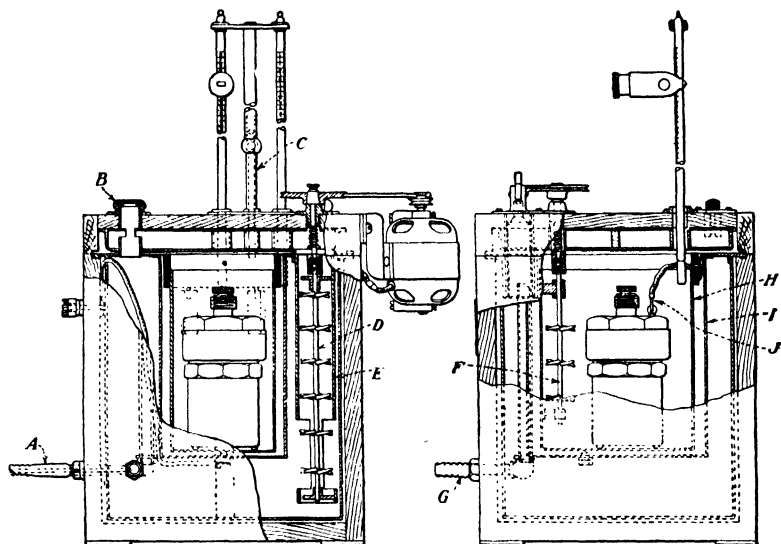

FIG. 74.—Cross-section of adiabatic oxygen bomb calorimeter.

oval in form and fitted to allow a minimum air space between this casing and the oval water container. Surrounding the casing, *I*, is the jacket into which the second thermometer extends, and through which water is circulated. An exact temperature control of this water is secured by a hot and cold water supply with inlet jets, at *A*. By means of the stirrer, *D*, which is enclosed in housing *E*, water is forced up into the interior of the cover whence it returns through the opening provided on the opposite side of the cover. The same stirrer also provides a circulation of the water within the jacket. This circulation is very rapid and, consequently, in the equaliza-

tion of temperature, the effect of lag is reduced to the vanishing point.

Procedure.—If a regular supply of hot water is not available, the heater shown in Fig. 73 may be used. Connect it to the calorimeter with two short pieces of heavy rubber tubing. If the heater operates under city pressure, the rear supply pipe is best connected through a $\frac{1}{4}$ -in. globe valve, direct to the laboratory piping.

Connect the overflow drain, *G*, through a $\frac{1}{2}$ -in. hose to the sink, taking care to avoid kinks as this outlet must be able to handle a rapid rise in the water level when either the hot or cold water supply is turned on.

To open the calorimeter, raise the thermometers by sliding their support upward to the limit of its travel and locate it in that position by the thumbscrew. It will be noted that the thermometer safety bar, *C*, prevents side motion of the cover until the thermometers are clear, thus preventing breakage. Raise the cover by means of the cam lever at the left rear. The cover may now be swung aside, giving access to the interior of the calorimeter.

The oval bucket is then lowered into the casing *I*. The locating plate and guides in the upper part of the casing serve to align the stirring shaft with an automatic coupling under pulley.

Transfer the bomb carefully, without jarring, to the oval can which has been placed in position in the calorimeter. The long axis of the oval should be in line with the operator, that is, at right angles to the work desk. The circular elevation in the bottom which directs the locating of the bomb should be toward the operator. Turn the bomb so that one of the faces of the octagon, rather than an angle, will be toward the operator, thus giving more room for the thermometer. Make connection with the electrical terminal by pressing part *J* on the post provided on the bomb.

Pour 2,000 grams of distilled water into the jacket, swing the cover into place and close it with the cam lever. Slide the thermometers down into position. The motor is attached to the cover and the two rubber belts are already in place.

The connecting cord is attached to the two binding posts on the side of the calorimeter jacket and the motor is started by

turning on the switch in the connecting cord. Make certain that water is flowing through the cover by observing through the peep glass *B*. Meanwhile the cold water should be turned on in order to replace the water which is taken from the jacket to fill the cover. As soon as water flows from *G*, the jacket is full and the cold water should be turned off. A brisk flow of water from the jacket cover back into the calorimeter jacket, as observed through the peep glass, indicates proper functioning of the circulating system.

Before starting combustion, the temperature of the jacket should be brought to the same temperature as that of the water surrounding the bomb. This is accomplished by injecting hot or cold water as required, and by a little practice the operator will learn the proper timing of the jets to secure the desired rise or fall in temperature. When the two thermometers read alike, they should be maintained in this relation for 2 or 3 min., in order to make sure that exact equilibrium conditions have been established. Record this temperature as the *initial reading*.

The charge is now ignited by pressing the ignition switch on the cover of the calorimeter. When the ignition switch is pressed, the pilot lamp will light and remain until the ignition wire fuses. This should occur within approximately 2 sec., at which time the ignition switch should be released. The temperature of the jacket should be advanced with that of the inner system until equilibrium is again established. Record the *final reading*. During the period of rise the thermometers may be slightly separated as to their temperature indications, but such variations will not introduce measurable amounts of radiation loss or gain, unless continued over a considerable length of time. Moreover, it should not be difficult for the operator to confine such variations within one-tenth of a degree or less. As the final step is approached, these variations may be reduced to the point of practical elimination.

The corrections and calculations are as follows:

- a. Apply corrections for the thermometers at the initial and final readings.
- b. Multiply the rise by the water equivalent of the instrument.
- c. Subtract the heat units due to the formation of HNO_3 , H_2SO_4 and burning of the fuse wire as explained in a previous section.

No radiation corrections are necessary. Assuming that a 1-gram charge of combustible was used, the computations (a), (b) and (c) will give the final result.

Example of Computation

Laboratory No. 7968

Date—Dec. 10, 1929

Weight of material burned.	0.8 gram		
Sulfur in coal.....	4.31 per cent		
Ash in coal.....	12.0 per cent	Room temperature.	74°F.
Moisture, air-dry.....	3.5 per cent	Water equivalent..	2416.00
Moisture, as-received.....	9.0 per cent		

Readings

Time		Temp.		
Hr.	Min.	Sec.	°F.	
2-11.00	75	72.5	Initial temperature.....	75.75
12.00	75	73.8	Correction.....	- 0.01
13.00	75	74.5	Corrected initial.....	75.74
14.00	75	75.0	Final temperature.....	80.22
15.00	75	75.0	Correction.....	+ 0.02
(a) 16.00	75	75.0 (fired)	Corrected final.....	80.24
			Corrected initial.....	75.74
			Corrected rise.....	4.50

(b)

(c) 21.00... 80.20

22.00... 80.22

23.00... 80.22

2-24.00... 80.20 (final)

Total B.t.u. = $2,416 \times 4.50$ = 10872.0

Acidity titration = 48.90

Correction for wire = 10.20

Sulfur correction $8 \times 4.31 \times 23$ = 79.30 138.4

B.t.u. for 0.8 lb. 10733.6

B.t.u. per pound 13417.0

Remove the bomb from the calorimeter water and open the valve carefully so as to allow the gases to escape at an approximately even rate so that the pressure is reduced to atmospheric in not less than 1 min. Open the bomb and examine the inside for traces of unburned material or sooty deposit. If these are found, the determination should be discarded. Wash carefully all parts of the interior of the bomb, including the tray, with a fine jet of distilled water containing 1 cc. per liter of a saturated

solution of methyl orange until no acid reaction is observed. It is essential to wash the valve opening as considerable spray may collect therein.

Collect the washings in a 250-cc. beaker and titrate with standard alkali solution to obtain the "acid correction" for the heating value, as specified under Corrections for Acids, page 229. Add 1 cc. NH_4OH (sp. gr. 0.90), heat the solution to boiling and filter through qualitative filter paper. Wash the residue and filter paper thoroughly five or six times with hot, distilled water. To the filtrate and washings, amounting to about 250 cc., add 1 cc. saturated bromine water and sufficient HCl to make slightly acid. Boil the solution to expel the bromine. Adjust the acidity and precipitate, and determine the sulfur by the usual gravimetric procedure.

CHAPTER XXVI

THE CALORIMETRY OF FUELS—THE SODIUM PEROXIDE CALORIMETER

Another type of calorimeter (Fig. 75) is extensively used in which the coal is mixed with a chemical which will supply the oxygen to complete the combustion within a closed cartridge.

This method is more conveniently available perhaps for technical work.

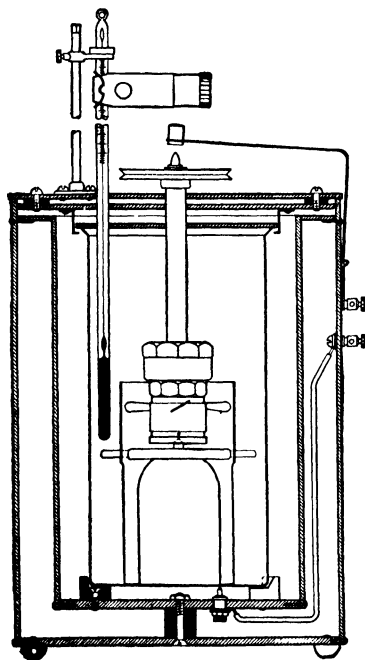
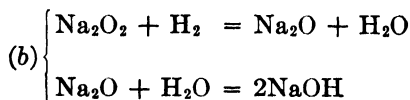
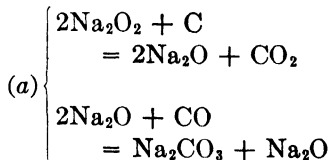

FIG. 75.—Parr peroxide calorimeter showing details of construction.

Principles.—The principles involved are as follows: Sodium peroxide (Na_2O_2) when mixed with coal in suitable proportion and ignited may be made to burn or react through an appreciable period of time but, instead of the formation of gaseous products as in the ordinary process of combustion, the CO_2 and H_2O unite with the chemical employed to form the carbonate and hydrate of sodium, which are solids. These reactions shown in detail are as follows:



Of the total heat developed in the reactions under (a), 73 per cent represents the heat of combination between the carbon and oxygen. Also, under (b) the total heat of the reactions is made up of 73 parts, which includes the heat formed by the union of the hydrogen with the oxygen; and 27 parts, which represents the secondary reaction or combination of the water with the chemical. This distribution of heat values is fortunate for the reason that we may make the factor 0.73 a constant which represents the part of the total heat to be taken as the equivalent of the heat of ordinary combustion. Other corrections must be applied to the indicated rise in temperature as detailed in the method of operation.

By reference to Fig. 76, there is shown a jacketing support for the fusion cup, while in the space surrounding the sides and bottom of the fusion cup is entrapped air which will not escape, except upon heating and expansion due to ignition of the charge. During the fusion period, therefore, the walls and bottom of the fusion cup become red hot. Cooling begins after about 2 min., at which time water is drawn in through vents near the lower edge of the holder to replace the air driven out by the heat. This accession of water into the air space during the cooling period is as important as the retention of air during the combustion period. The latter insures completeness of combustion and the former insures quick and complete transmission of the heat to the surrounding water.

Directions for Operating. *General.*—The calorimeter should be placed in a room where fluctuations of temperature may be avoided. The general arrangement of parts is shown in Fig. 75. The outside of the can should be dry and no water should be allowed to spill over into the air spaces of the insulating vessels.

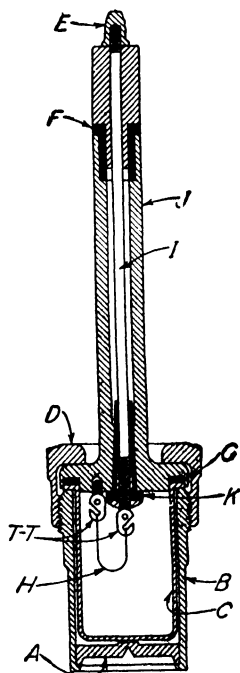

FIG. 76.—Peroxide calorimeter bomb showing details of construction.

Exactly 2 liters of water (preferably distilled) are used and it should have a temperature of 2 or 3°F. below that of the room. The thermometer should extend a little over half-way to the bottom of the can. The pulley is connected by a light, flexible cord with a small electric motor. Stirring is effected by the spring clips with turbine wings placed on the bomb. The pulley must be made to revolve at about 150 r.p.m. Uniformly maintained, this will insure a complete equalization of temperature throughout the water.

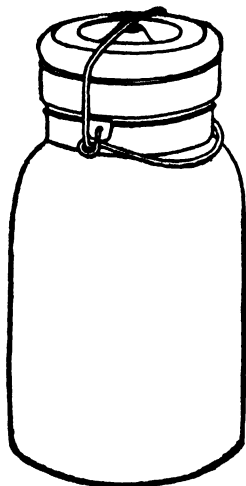

FIG. 77.—Container for sodium peroxide.

The Chemical: Sodium Peroxide (Na_2O_2). It is absolutely necessary that the chemical employed (sodium peroxide) be kept free from contamination. It has special avidity for moisture and the glass jar with lever fastener shown in Fig. 77 has been found best adapted as a container for this material. The sodium peroxide is furnished in small, sealed tins, and the entire contents of a can upon opening should be transferred completely to the jar. The $\frac{1}{2}$ -lb. tins will usually be found the most convenient size to use. In any event, it is best to use a glass jar of sufficient size to permit of the complete emptying of the container for storing the chemical. The

measuring dipper should also be kept in the jar. Commercial sodium peroxide or material that has been exposed to the air so that any considerable amount of moisture has been absorbed will give variable and uncertain results. The sodium peroxide usually furnished with the apparatus is especially prepared under uniform conditions and is enclosed in solder-sealed tins in order that the material may come to the user in the best possible condition.

The Accelerator: Potassium Perchlorate KClO_4 .—For reasons not at first readily understood, the use of an accelerator is necessary in order to obtain complete and consistent reactions. The accelerator used for a long time was potassium chlorate (KClO_3), but since the perchlorate salt KClO_4 has come to be readily available, it has displaced the earlier chlorate as an accelerator.

The chief reasons for the change can be readily understood. For example, the ordinary chlorate in decomposing from KClO_3 to $\text{KCl} + \text{O}_3$ is exothermic and its heat of decomposition must be included as part of the correction factor to be applied. It is advantageous to eliminate that correction, not only on the score of simplification but, in the presence of the organic matter of the charge, this decomposition of KClO_3 has a tendency to be unduly rapid or boisterous and especially so if by chance the operator should forget to add the 15 grams of sodium peroxide, called for in making up the charge. Under such conditions, the mixture has the property of gunpowder in the speed of its reaction. On the contrary, a mixture of perchlorate and coal alone does not constitute an explosive mixture.

The function of an accelerator may be explained as follows: The heat of the reaction brings the charge to a liquid state and, neither at that stage nor immediately following where it becomes solid, could an atmosphere of free oxygen, as used in the Atwater method, contribute greatly to the completeness of the reactions. On the other hand, if the accelerator is brought to a high degree of fineness, say, 100 mesh and evenly distributed throughout the mixture, the oxygen liberated by the accelerator is not only at the exact spot where it is needed but is also at the moment in the nascent state. Under these conditions there is secured not only a complete oxidation of the organic matter but any reactions which would otherwise rob the Na_2O_2 of an atom of oxygen have at hand compensating conditions which bring the Na_2O back to its normal and more stable condition of Na_2O_2 .

It has been found that a mixture of coarse and fine crystals of accelerator give variable results and that to secure uniformity as well as the full effect of the accelerator, it should be used in some definite form. The material supplied with the instrument has been passed through a 100-mesh sieve. If lumps form in the bottle as a result of packing and standing, these should be broken down to powder again before adding to the charge.

Making Up the Charge.—It is assumed that the usual method of sampling a shipment or storage pile, as described in Chapter XXIII, has been followed. If the amount of moisture in the air-dried coal is more than 2 per cent, drying in the oven is necessary before the determination of

calorific value is made (see note [h] for a detailed discussion of this point).

In general, the charge for an ordinary sample of coal consists of the following: 0.5 gram of coal; 1.0 gram potassium perchlorate (KClO_4); and one full measure sodium peroxide (special grade for calorimetric purposes).

The fusion cup should be thoroughly dry before adding the charge. It is well to dry it over a radiator or hot plate, though it should of course be cooled for filling.

In the same manner, dry the cover and see that the fuse wire *H* is in place (Fig. 76). To attach the ignition wire, cut a single length of wire 7 cm. long from the card; pass one end through the eyelet of one of the terminals *T-T*, so it will extend beyond the eyelet, say $\frac{1}{4}$ in. Wrap the free wire around the terminal at the narrow portion formed by the notch, giving it three turns, binding in the free end and bending the wire finally downward in line with the terminal. Repeat the same process with the other end of the wire in the other terminal. Do not have the fuse loop too long. It is better to extend it just below the surface of the charge.

Transfer the various ingredients to the fusion cup in the order indicated. In filling the measuring cup with peroxide, it should be tapped against the side of the glass jar to insure against the formation of air pockets which might prevent the complete filling of the measure. The measure holds approximately 15 grams. The same precaution as to dryness of the measuring cup should be also observed for the fusion cup. It should be rinsed thoroughly with tap water after each using and dried by heating over a radiator or near a hot plate.

After adding the sodium peroxide, cover at once with the false cap. It is well to prepare two charges simultaneously for duplicate determinations.

See that the floating bottom *A* is in place at the lower end of the bell body. Put the fusion cup and contents in the bell body, which is most suitably held in the octagon socket support. Fasten the false cap in place by means of the screw cover *D* and shake thoroughly until the ingredients are evenly mixed.

When the mixing is complete, tap the cup lightly on the desk to shake all of the material from the upper part of the container,

remove the false cap and put in its place the regular cap with stem and ignition wire.

The gasket *G* should be in good condition and the stem cap should seat properly. It is to be noted that the gasket seals both the upper edge of the fusion cup and also the upper edge of the bell body. Marring the rims or surfaces of any of these parts, therefore must be carefully avoided. Screw down the cap firmly in place by use of the wrench. The assembled bomb is now removed from the holder and the spring clips added with the stirring vanes upward to assist in holding the bomb in an upright position. Add to the can exactly 2 liters of water at a tempera-

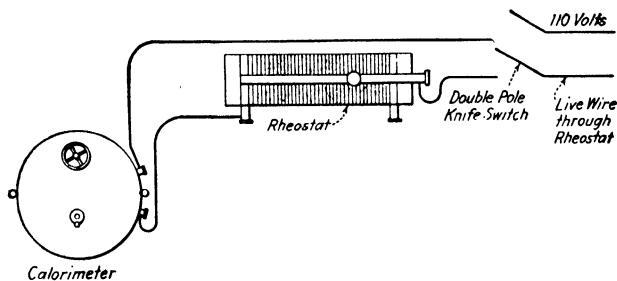

FIG. 78.—Wiring for ignition on 110 or 220 volts, either alternating or direct current.

ture slightly below that of the room and assemble as shown in Fig. 75. Put on the belt and start the motor. The placing of the belt should be such that the pulley will turn clockwise and at the rate of about 150 r.p.m.

Ignition.—The current required for igniting the charge should be from 2 to 4 amp., and is most readily obtained by means of a rheostat or resistance placed in series in an ordinary lighting circuit of 110 volts (see wiring diagram, Fig. 78).

Make several preliminary tests by fastening a loop of fuse wire to the terminals and passing the current without assembling the parts. In this way the behavior of the fuse wire can be observed. The wire should come quickly to incandescence after closing the circuit and melt in 1 or 2 sec. The resistance may be adjusted to give the proper time of fusion. A fuse wire of high resistance is better suited than iron wire for this purpose.

Temperature Readings.—Because of the extended use of the peroxide calorimeter by engineers in connection with the checking of coal deliveries, etc., these instruments are ordinarily supplied with thermometers graduated in degrees Fahrenheit. Results are thus given directly in B.t.u. In this discussion concerning the use of the peroxide calorimeter, therefore, that type of thermometer is assumed to be the one used.

The thermometer is inserted so that the lower end of the bulb will be about midway toward the bottom of the can. The pulley should be allowed to revolve a few minutes before reading the thermometer in order to equalize the temperature throughout the apparatus. Take readings 1 min. apart for four or five intervals before igniting the charge and continue the same for 9 or 10 min. subsequent to ignition. The first three or four readings after ignition are roughly taken but after the fourth or fifth minute the temperature should be nearly equalized, and the readings must be carefully taken in order to ascertain the exact maximum and to furnish the necessary data for making a correction for radiation. If the temperature of the water before ignition is 1 or 2° below that of the room, the temperature at the end of the first minute after ignition will be something above that of the room, and radiation for that period may be considered as self-correcting. Ordinarily the rise in temperature will continue for about 5 min. more, at which time the maximum temperature will have been reached. The radiation for this period is found as follows: Read the fall in temperature for each minute for 4 min. after the maximum has been reached. The average drop per minute represents the correction to be added to each minute preceding the maximum, except for the minute immediately following ignition. The final temperature thus corrected for radiation, minus the initial reading before ignition, represents the total rise in temperature due to the reaction in the fusion cup.

In reading the thermometer a suitable lens should be used preferably mounted in a manner to eliminate errors of the parallax. Tap the thermometer lightly before taking a reading in order to avoid irregularities in the surface of the mercury. It should be remembered that errors in reading the thermometer are multiplied many times in the final computation. Equalization of temperatures should be complete in about 5 min. This

will always be the case if, in the process of cooling, water has been drawn into the narrow air spaces surrounding the fusion cup. If by some mischance this entrance of the water should fail to take place, it will be indicated by an absence of water within the holder around the bottom and lower part of the fusion cup. It will be evident also by a slow but very evident rise of the mercury over a period of 10 or 15 min., due to the slow conductance of the heat through the limited areas of metal contact between the holder and the cup.

The Correction Constants.—After corrections have been made for radiation and thermometer variations, as described in the previous chapter, further corrections depending on the material used are listed for convenient reference as follows:

Fuse wire and electric resistance.....	0.005°F.
Ash, multiply the per cent by.....	0.005°F.
Sulfur, multiply the per cent by.....	0.010°F.
Accelerator (KClO ₄).....	0.200°F.

In addition to the foregoing corrections, the “younger” coals have a “hydration factor” due to hydroxyl constituents which are corrected for as follows:

Bituminous coals, high and low volatile.....	0.070°F.
Sub-bituminous coals.....	0.170°F.
Lignites.....	0.220°F.
Anthracites and cokes have no hydration factor. Petroleum coke has a correction the same as for bituminous coals, namely	0.070°F.

Where benzoic acid is used as a constituent of the charge, as directed under anthracites, petroleums, etc., a correction factor is applied corresponding to the amount of benzoic acid taken, as follows:

Total rise for combustion and hydration (0.3 gram benzoic acid) 2.313°F.

Calculations.—From the total rise in temperature, corrected for thermometer variation and for radiation as indicated under Temperature Readings, subtract the correction factors for the heat due to the chemical, fuse wire, etc., as indicated under Correction Constants, and multiply the remainder by 3,100.¹

¹ The factor 3,100 is the water equivalent used for all peroxide calorimeters. This value is maintained by precision manufacture and control of the weight of materials used.

The product will be the number of B.t.u. per pound of coal (see notes (a) and (b), page 254).

Example.—Sample 921, bituminous coal

	Per Cent	
Ash.....		13.40
Sulfur.....		4.22
Moisture, air dry.....		5.00
Moisture, as received.....		10.00
Temperature Readings		
Room temperature.....		72°F.
Readings		
Time		
1.....	69.45	
2.....	69.50	
3.....	69.60	
4.....	69.75	
5.....	69.90	
6.....	70.00 (fired)	
7.....	71.00	Initial temperature.. 70.00 Final..... 74.250
8.....	73.50	Certified correction.. 0.00 Correction -0.010
9.....	73.90	
10.....	74.20	70.00 74.240
11.....	74.25 (maximum)	
12.....	74.25	Average radiation loss from 11th to 15th
13.....	74.20	min. = (74.25 - 74.00) ÷ 4 = 0.06 per
14.....	74.10	minute.
15.....	74.00	Correction = 4 × .06 = +0.24..... 0.240
		<hr/>
Final temperature correction for radiation.		74.480
Correction factors		
Fuse wire.....		0.005
Ash, 13.40 × 0.005.....		0.067
Sulfur, 4.22 × 0.01.....		0.042
Accelerator.....		0.200
Hydration.....		0.070
		<hr/>
		0.384
Corrected final.....		74.096
Corrected initial.....		70.000
		<hr/>
Corrected rise.....		4.096
Constant, 3,100 × 4.096 =		12,698 B.t.u.

It is to be noted that the heat value as derived refers to the coal in the form in which it is weighed out for making the determina-

tion. That is to say, if a coal having 5 per cent of moisture is taken and $\frac{1}{2}$ gram of the same weighed out and dried in the oven at 212° for 1 hr., then burned in the calorimeter, the result obtained refers to the coal on the basis of 5 per cent of moisture and not to the coal as in the oven-dry state.

To calculate values to the "dry-coal" basis, divide the number by 100 per cent minus the percentage of moisture present. Thus a coal having 5 per cent moisture as weighed out, and indicating 12,698 B.t.u., would have $12,698 \div 0.95 = 13,366$ B.t.u. on the dry-coal or moisture-free basis.

Of course, the ultimate value desired is on the coal in its initial or "as-received" condition. To obtain this value multiply the B.t.u. found for dry coal by 100 minus the total moisture, as-received. For example, a coal having 10 per cent total moisture and indicating 13,366 B.t.u. on the dry basis would have

$$13,366 \times (1.00 - 0.10) = 12,029 \text{ B.t.u., as received.}$$

Dismantling the Calorimeter.—Remove the thermometer, pulley and cover, then take out the can and contents entire so that the lifting out of the cartridge will not drop water into the dry parts of the instrument. Remove the spring clips and unscrew the cap. Remove the fusion cup and place it on its side in the bottom of a beaker, cover with a watch glass and add hot water. After the fused material has dissolved, remove the cup and rinse thoroughly with hot water. Wash the face of the cap and electric terminals thoroughly. For this purpose submerging in boiling water is advisable, as the metal is thus left clean and hot, the latter facilitating the drying out of the parts. Place the parts on a radiator or near a hot plate to insure thorough drying. Drain the can and wipe the interior dry with a towel after each operation.

Anthracites and Coke.—In the case of anthracites and coke, use 0.3 gram of benzoic acid along with 1 gram of accelerator and 0.5 gram of fuel. This substance facilitates ignition as well as the ultimate combustion. The heat resulting from the combustion of this extra 0.3 gram of benzoic acid is 2.313°F. which is to be corrected for, along with the other components, as already noted in the table of constants.

For hard fuels, such as coke and anthracites, fine grinding is essential. It is advisable to use an agate mortar for supplementary grinding of the sample.

Petroleum Oils.—The amount of oil used for a charge should not exceed 0.3 gram, from 0.2 to 0.3 gram giving the proper combustion. The weight of oil is best obtained by means of a small, light, 15-cc. weighing flask, provided with perforated cork and dropping tube with common rubber bulb-cap. Weigh the flask and contents and, by means of the dropping tube, discharge 20 to 30 drops of oil and reweigh, thus obtaining by difference the weight of oil taken. Determine by experiment the height in the dropping tube required for the approximate amount of oil desired so as to avoid trial weighings.

One gram of accelerator $KClO_4$ and one full measure of chemical (sodium peroxide), together with 0.3 gram of benzoic acid and the proper amount of oil are added and thoroughly shaken as already indicated.

Note that thorough mixing by shaking is not easily accomplished in the case of thick viscous oils. After adding the accelerator and benzoic acid, the thick oil should be added and stirred with a small glass rod or wire till an even mixture is secured. Add the sodium peroxide, enclose in the bomb and shake thoroughly to insure an even distribution of the oil throughout the charge.

Compute by means of the formula as follows:

Correct for thermometer variation, radiation, accelerator and benzoic acid, and fuse wire, and letting r represent the rise in temperature, then

$$\frac{r \times 0.73 \times 2,123.3}{\text{Weight of oil}} = \text{B.t.u. per pound of oil}$$

For the value 2,123.3 see note (a) under Standardization.

Gasoline, Etc.—For gasoline, benzine, and other very volatile hydrocarbons, the difficulty of securing an accurate weight of the material taken is met as described in the preceding chapter as follows: Draw out an ordinary soft-glass tube into a capillary about 1 mm. in diameter. By softening the end it may be blown into a small thin-walled bulb, as shown in Fig. 71. After a little practice it is not difficult to blow such bulbs to weigh less than

0.2 gram. They are used as follows: Weigh the bulb carefully; then by dipping the capillary end into the liquid and alternately warming gently and cooling the bulb, a quantity of the liquid may be made to flow up into it. When about 0.2 gram is obtained seal the tip of the capillary in the flame and weigh accurately. Add the accelerator to the fusion cup in the usual manner, reducing any lumps to a fine powder. Add also the 0.3 gram carefully weighed standard benzoic acid and the bulb containing the liquid fuel; then, over all, the measure of sodium peroxide. Press a glass rod down through the chemical above the bulb, just sufficient to break it. Remove the rod which should be freed from adhering particles by cleaning it in the upper part of the sodium peroxide as yet unmixed with any of the other ingredients. Put in place as quickly as possible the ignition top with fuse wire attached, and clamp firmly by means of the screw cap. Shake very thoroughly to insure complete mixing of the charge. Tap lightly on the desk to bring all of the material together and assemble for the regular procedure. In calculating, a correction is necessary in addition to those normally observed on account of the heat of fusion due to the glass present. This amounts to 0.03°F . for each 0.1 gram of glass used in the bulb and should be subtracted along with the correction for accelerator, benzoic acid and fuse wire. The corrected rise r is then used in the formula as given for petroleum.

Standardization.—A number of methods for the standardization of the peroxide calorimeter may be used.

1. By calculating the water equivalent for the metal a very satisfactory factor is obtained which serves as a constant in calculating the heat values. The accuracy of this method in connection with the peroxide type of instrument is due to the relatively small amount of metal employed in its construction, together with the fact that all metal parts, in the process of manufacture, are standardized as to weight. The total weight of metal, not including the pulley and insulated part of the stem, is approximately 1,370 grams. Applying a specific heat value of 0.090 gives a water equivalent for the metal of 123.3 or a total water-equivalent value of 2,123.3, which is the basis for determining the constant of 3,100, as shown by note (a) on the following page.

2. A standard coal for which the heat value has been accurately derived by an oxygen-bomb apparatus of the Mahler type. This requires that the Mahler value be recently determined owing to the change in the apparent heat value of coal samples upon standing. It has the advantage, however, of checking the peroxide instrument with respect to the correction factors used for ash, sulfur and water of composition or "hydration."

Too much emphasis cannot be placed on the necessity of using a high-grade and thoroughly reliable thermometer.

Notes.—*a.* The factor 3,100 is deduced as follows: The water used plus the water equivalent of the metal in the instrument amounts to 2,123.3 grams. In the reaction, 73 per cent of the heat is due to combustion of the coal, and 27 per cent is due to the heat of combination of CO₂ and H₂O with the chemical. The standard charge contains exactly 0.5 gram of coal. Therefore, to obtain a single value involving these three factors, multiply the water equivalent of the calorimeter (2,123.3) by 0.73 which gives grams of water heated by the combustion of 0.5 gram of coal, and then multiply by 2 giving the grams of water heated by the combustion of 1 gram of coal.

$$2,123.3 \times 0.73 \times 2 = 3,100$$

If the thermometer is graduated in Centigrade degrees, the use of the factor 3,100 will give the result in calories. If the thermometer is graduated in the Fahrenheit scale, the use of the factor 3,100 will give the result in B.t.u.

b. In the process of igniting the charge, prolonged contact of the electric terminal should be avoided, otherwise there will be an undue accession of heat from the passage of the current. If the resistance is so adjusted that the wire, in trying out, comes to the melting point in 1 or 2 sec., then that amount of time is ample for maintaining the electrical contact. A positive rise indicates that combustion has commenced. In such a case, do not make the contact again. It may happen that the fuse wire, after igniting the charge, extends into the fusion thus making it possible to complete the electrical circuit a second time.

c. Do not bring the instrument from a cold room to work at once in a warm room, or *vice versa*. Sufficient time should be given for equalization of temperatures. Dry the bomb thoroughly inside and out before putting away. Dry it before using if it has stood for some time, as moisture condenses on the surfaces.

d. Do not throw a mixture of chemical and unburned coal in the water. It may ignite violently.

e. Determinations are sometimes required on material too low in carbonaceous matter to support combustion, such as ash residues, etc. If the combustible matter is below 20 or 30 per cent, double or treble the quantity, and in calculating, use one-half or one-third of the corrected rise. Note

that the corrections for ash and sulfur, as indicated under Correction Constants, page 249, should be doubled or trebled in accord with the doubling or trebling of the material taken. Ash residues that have come through a combustion chamber are like coke. It is well in such cases to use 0.3 gram of benzoic acid as indicated under Anthracite and Coke, together with 1 gram of accelerator, the correction for the benzoic acid being 2.313°F.

f. In measuring water from the 2-liter flask, read the mark at the bottom of the meniscus. Where two marks are etched on the neck, the upper mark shows the volume at which the required quantity will be discharged from the flask and of course is the one to be used in measurement. A balance with counterpoise for weighing the water is preferred where available.

g. If it is found difficult to differentiate between readings for radiation that are made 1 min. apart, extend the periods to 2 or 3 min., making the final adjustment to cover the time actually to be corrected for.

h. Concerning the amount of moisture permissible in the fuel sample it has been indicated¹ that the temperature rise in the apparatus as used, due to the absorption by the chemical Na_2O_2 , of 1 gram of water is 0.663°C. In a 0.5-gram sample, therefore, 2 per cent of moisture would represent 0.01 gram of water, which, if allowed to combine with the Na_2O_2 , and if all the heat generated by that absorption were included in the calorimetric process, would produce a rise of $0.01 \times 0.663 = 0.0066^\circ\text{C}$. This temperature rise would then cause an error of $0.0066 \times 3,100 = 20$ cal., which will give sufficient reason for avoiding the use of a coal with a high percentage of moisture. The error for free moisture would be less than the calculated amount, due to dissipation of the heat of absorption before the thermometric readings were taken, but the possibility of an appreciable error is easily guarded against by oven drying for samples with high moisture.

¹ Constants of the Parr calorimeter: *Jour. Am. Chem. Soc.*, vol. 29, p. 1616, 1907.

CHAPTER XXVII

SULFUR DETERMINATIONS

General Statement.—In the ordinary proximate analysis the sulfur content of coal is distributed between the volatile matter and the coke. This distribution follows no definite plan, although very frequently the sulfur divides itself about equally. Since the sulfur is thus included in the factors obtained, the results total 100 per cent. The factor for sulfur, therefore, is independent of the other components and to avoid confusion should be reported on a separate line and not listed with the constituents determined by proximate analysis.

The sulfur content is primarily of interest to the analyst because of the necessity of knowing this factor in making the calorimetric corrections for both the peroxide and the oxygen bombs. The user of the coal in combustion processes looks upon the sulfur percentage as a fairly reliable index of the tendency of the coal toward clinker formation. The gas and coke maker prescribes a low percentage as a maximum quantity beyond which the coal is unsuited for this purpose. In all these cases, therefore, the total sulfur content is required and the methods of analysis are mainly directed to this end. For some purposes, however, the ratio of distribution as between the mineral or pyritic sulfur and that which is in organic combination is desired. Complete directions for this separation and analysis may be found by reference to the literature.¹

Total Sulfur in Coal.—*a.* The washings from an oxygen-bomb calorimeter give values which are sufficiently accurate for the corrections needed in the use of that instrument. The washing should be thorough and hot water is preferred. Heat the washings to boiling with a few cubic centimeters of dilute (1:1) HCl, to which a little bromine water has been added. The ash and

¹ POWELL, A. R., with PARR, S. W., Determination of sulfur forms in coal: *Our. Ind. Eng. Chem.*, vol. 12, p. 887, 1920.

insoluble sulfates remaining should be filtered off and also washed with hot water. Make neutral to methyl orange by means of sodium hydroxide or carbonate, acidify with 1 cc. of approximately normal HCl, and heat to boiling. The bulk of the solution should not exceed about 200 cc. Add slowly from a pipette, with constant stirring, 10 cc. of a 10 per cent solution of barium chloride ($\text{BaCl}_2 \cdot 2\text{H}_2\text{O}$). Continue boiling for 15 min. and allow to stand for 2 hr. or over night. Decant the supernatant liquid, filter through an ashless filter and wash thoroughly. Transfer the wet filter to a weighed crucible and smoke off the paper carefully to avoid spattering, and so slowly that the filter paper does not burn with a flame. Finally, heat to 900 or 950°C. and weigh. The amount of sulfur in BaSO_4 is 13.736 per cent.

Attention should be called to the following notation made in the preliminary report of the Committee on Methods of Sampling and Analysis of Coal.¹

b. The Eschka method has been long in use and is frequently the standard of reference. It has the disadvantages of being long and requiring careful regard to sulfur in the reagents and the gas used for heating. The Eschka mixture is prepared by incorporating 2 parts of magnesium oxide with 1 part of sodium carbonate and passing through a 40-mesh screen.

Weigh out 1 gram of coal and thoroughly mix with 3 grams of the Eschka mixture. This is best carried out on a sheet of glazed paper from which it is transferred to a No. 0 porcelain or other suitable crucible and covered with about 1 gram additional of Eschka mixture. Heat gradually in a muffle till a final temperature of approximately 900°C. or a cherry red is attained. Continue the heating with occasional stirring for about 1 hr., or until all particles of carbon have been burned. Cool and digest with about 100 cc. of hot water for $\frac{1}{2}$ to $\frac{3}{4}$ hr. Filter by decantation and wash the residue a number of times with hot water. Finally, transfer to the filter and wash four or five times. The filtrate should not exceed 250 cc. Add 10 to 20 cc. of saturated bromine water. Acidify and boil to expel the bromine. Make neutral to methyl orange by means of NaOH or Na_2CO_3 and add 1 cc. excess of normal HCl. Precipitate, as under (a) and complete

¹ *Proc. Am. Soc. Testing Materials*, vol. 14, p. 432, 1914.

the gravimetric determination in the usual manner as there indicated. Blank determinations should be made on the reagents employed and corrections applied to correspond.

c. The method by fusion with sodium peroxide is in all respects the most convenient to use. The residue from a calorimetric determination may be utilized or a special bomb for sulfur determinations may be used. The fusion-cup method of ignition and making up the charge are the same in either case. Figure 79 shows the apparatus as assembled for firing by means

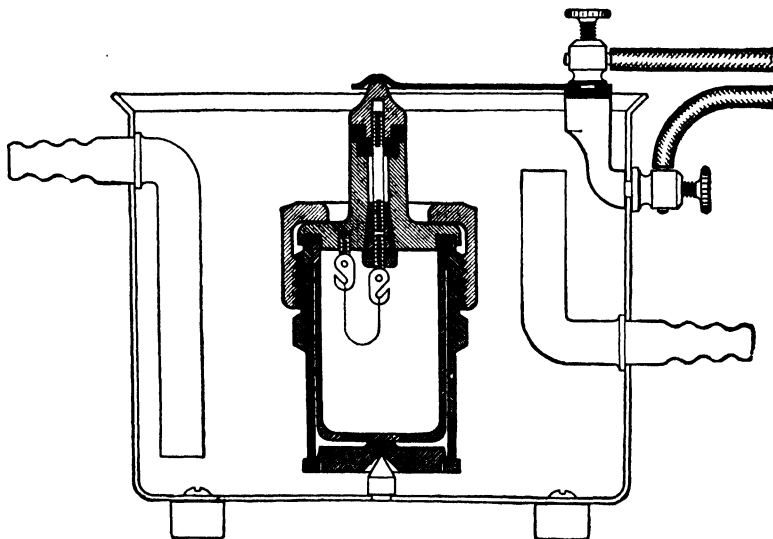

FIG. 79.—Cross-section of electric ignition sulfur bomb and water jacket.

of an electrical current. One gram of accelerator is placed in the bottom of the fusion cup and freed from lumps. One measure (15 grams) of Na_2O_2 is added and thoroughly mixed with the accelerator by shaking. The 0.5 gram of coal is then added and shaken. Some operators prefer to add the coal to the accelerator and mix the two with a glass rod and then add the peroxide with subsequent thorough mixing by shaking. If the peroxide is not forgotten, or if the mixing by shaking is not disregarded, that procedure is a good one. It is sometimes the practice to ignite the charge in the simple container shown in Fig. 80 by causing a pointed flame from a blast lamp to impinge upon the

bottom or side of the fusion cup for a brief period, sufficient to start the reaction. In such a case it is vitally important that the mixture of coal and accelerator (KClO_4) should be mixed throughout the peroxide which then serves as a diluent and slows down the reaction to a moderate speed, thus avoiding the explosive character of the perchlorate and coal alone. If therefore the Na_2O_2 is forgotten or the mixture of coal and perchlorate are left undisturbed at the bottom of the fusion cup, a serious explosion may result.

A pointed flame from a blast lamp is preferred instead of the full flame of a Bunsen burner. By such means a localized portion of the fusion cup becomes red hot and ignites the charge at one spot from which the reaction proceeds moderately throughout the mixture thus avoiding the violent reaction which may accompany the use of a full flame of large volume. After ignition has started, the reaction will be complete in a very short time so that after the lapse of 10 or 15 sec. the apparatus may be brought under the tap for cooling.

After the reaction is complete and the bomb is sufficiently cool to handle, remove the fusion cup and place in a small beaker of 250-cc. capacity. Add water and cover the beaker with a watch glass. After solution is complete, rinse and remove the fusion cup and add concentrated HCl to the neutral point. This will require 25 to 30 cc. of acid. Add about 1 cc. of normal acid in excess, filter if necessary, wash and make up the solution to about 225 cc. Precipitate the sulfates by means of barium chloride exactly as indicated under (a). Particular attention should be observed in washing the precipitate obtained by this method in order to remove all of the soluble salts which are formed in the fusion process.

d. The turbidimetric method for arriving at the factor for sulfur is extensively used and has many features of advantage especially in technical work. It is applicable to any of the solutions obtained under (a), (b) or (c), above, at the point where the solution is ready for precipitation by means of barium chloride. It is especially advantageous in Method (c) where the

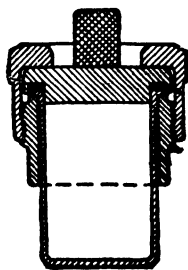

FIG. 80.—Sulfur bomb, common type for heat ignition.

peroxide fusion has been employed for the reason that separation from the heavy alkaline salts is not involved. The details of the process are given under the description of the sulfur turbidimeter.

Sulfur Turbidimeter.—The turbidimeter (Fig. 81) is a device which is a modification of the instrument originally known as the sulfur photometer. The principle involved is the prevention of

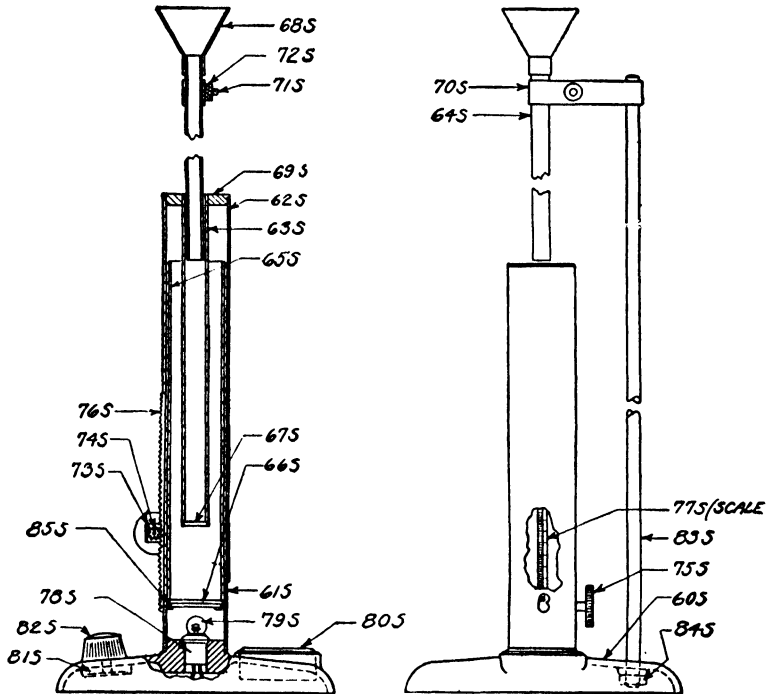

Fig. 81.—A turbidimeter for rapid sulfur determinations.

the direct passage of light through a column of solution by a suspension of barium sulfate. With a definite amount of turbid solution in this instrument, a system of telescoping tubes makes possible a variation in the depth of the solution between the source of light and the eye. The tube containing the solution is constructed of a material having opaque walls, in order to eliminate the effect of glare. An eyepiece provides a means for shutting out light from external sources. A voltmeter mounted

on the base of the instrument together with a rheostat permits an easy regulation of the lamp voltage and provides a means of maintaining it at a definite point.

Preparation of Solution.—After the fusion in a peroxide bomb has been completed and the solution neutralized with a slight excess of HCl, the solution is filtered and diluted to exactly 150 cc. instead of 400 cc. as for a gravimetric determination. After mixing thoroughly, it is then ready for taking a sample for the turbidimeter.

Volume of Solution for Turbidimeter.—The proper portion of the 150 cc. to be taken for the turbidimeter depends upon the percentage of sulfur in the original sample. If the sulfur content can be approximated, the following table may be used in determining the volume of solution to be taken when 0.5 gram of the coal or coke has been used in the sulfur bomb.

Percentage of Sulfur	Amount to be Taken
0.8—1.4 per cent	150 cc.
1.3—2.3 per cent	90 cc.
2—3.5 per cent	60 cc.
3—5 per cent	40 cc.
4—7 per cent	30 cc.

This sample is measured into a 300-cc. Erlenmeyer flask and the correct quantity of distilled water added to make a total of exactly 200 cc. One measure of barium chloride crystals is added, the flask stoppered and shaken vigorously for about 1 min. The turbid solution is then placed in the turbidimeter.

Reading the Turbidimeter.—After pouring the 200 cc. of the turbid solution in the turbidimeter, the plunger tube (63S) should be inserted in the solution tube (65S) and the eye tube (64S) and eye shield (68S) placed in position. The rheostat on the base of the turbidimeter is adjusted until a voltage of three volts is indicated on the voltmeter.

The depth of the solution is varied by movement of the adjusting stem (75S) and the end point taken at the complete disappearance of the filament. Although the end point may be approached from either direction, that is, the disappearance or appearance of the filament, the disappearance is found to be more convenient.

The reading in millimeters is shown on the scale on side of inner tube (61S). It is preferable that two or three readings be taken to obtain an average value.

Interpretation of Results.—By means of the standardization curve (Fig. 82) the milligrams of sulfur present may be determined for the indicated depth in millimeters. Assuming that

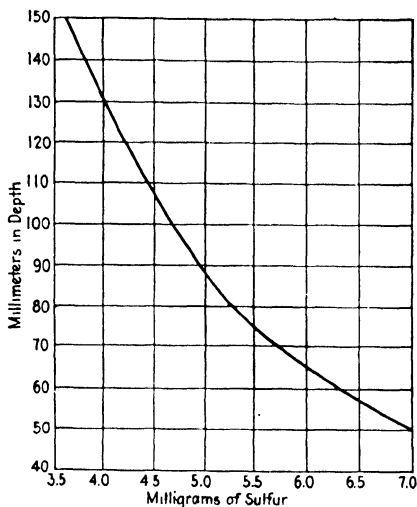

FIG. 82.—Typical curve for use with the sulfur turbidimeter.

0.5 gram of combustible material was used in the sulfur-bomb fusion, the percentage of sulfur is calculated as follows:

Portion Taken from 150 cc. of Solution	Percentage Sulfur (from Curve)
30 cc.	1 mg. S = 1 per cent
40 cc.	$\frac{3}{4}$ mg. S = 1 per cent
60 cc.	$\frac{1}{2}$ mg. S = 1 per cent
90 cc.	$\frac{1}{3}$ mg. S = 1 per cent
150 cc.	$\frac{1}{5}$ mg. S = 1 per cent

For example, if only 30 cc. of the 150 cc. of solution are used in the turbidimeter, this portion of the solution represents the weight of sulfur in one-fifth of the combustible material used in the sulfur bomb or in 0.1 gram. Therefore, a reading of 85 mm. would indicate 5 mg. of sulfur in 0.1 gram or 0.05 gram of

sulfur in 1 gram. The ratio of 0.05 gram per 1 gram original sample equals 5 per cent. Hence, when 30 cc. are taken from the original 150 cc., the milligrams of sulfur as read give directly the percentage of sulfur.

When the percentage of sulfur is lower than four, it is necessary to use a proportionately larger volume of solution from the 150 cc., which makes it necessary to multiply the value of milligrams of sulfur by the factors shown to obtain the percentage of sulfur. For example, if 60 cc. of the 150 cc. of solution give a reading of 85 mm., it would indicate 5 mg. of sulfur in 0.2 gram of the sample, or 0.025 gram of sulfur per gram. This would equal 2.5 per cent which means that when using 60 cc. of solution, the values in milligrams of sulfur should be multiplied by one-half to obtain the percentage of sulfur.

For cases of extremely low sulfur content, it may be necessary to combine two fusions from the peroxide bomb and evaporate to 200 cc. for the determination in the turbidimeter. Thus the reading in milligrams of sulfur would represent the sulfur in 1 gram of coal, coke or other combustible material and should be divided by 10 to obtain the percentage of sulfur.

Standardization of Turbidimeter.—Although the curve in Fig. 82 is based on readings taken by more than one operator, some operators desire to make their own standardization curve in order that variations in method of determining the end point, keenness of vision, etc., may not be the cause of a constant error in readings being made.

The procedure for checking the curve is to make up a solution of sodium sulfate by dissolving 0.4431 gram anhydrous sodium sulfate in distilled water and making up to 1,000 cc. A solution of this concentration contains 0.0001 gram or 0.1 mg. of sulfur per cubic centimeter of solution. To each sample taken is added 25 cc. of a solution containing 240 grams of pure sodium chloride and 20 cc. of concentrated hydrochloric acid per liter. (The purpose of this is to increase the salt content of the solution to approximately the same as that encountered in the solution from the peroxide fusion. Such a condition also improves the stability of the colloidal barium sulfate.) The solution is then made up to exactly 200 cc. with distilled water and one measure (15 grams) of barium chloride crystals are

added. The determination is completed in the manner described above.

Sulfur in Petroleum Oils Heavier than Illuminating Oil.—(a) Where the sulfur is above 0.5 per cent it is entirely practicable to make a fusion in the peroxide bomb. However, it should be noted that the maximum amount of oil that can be used in a charge is 0.2 to 0.3 gram.

The ingredients should be added to the fusion cup as follows: First, add 1 gram of accelerator KClO_4 . See that all lumps are removed by crushing with a small pestle in the bottom of the

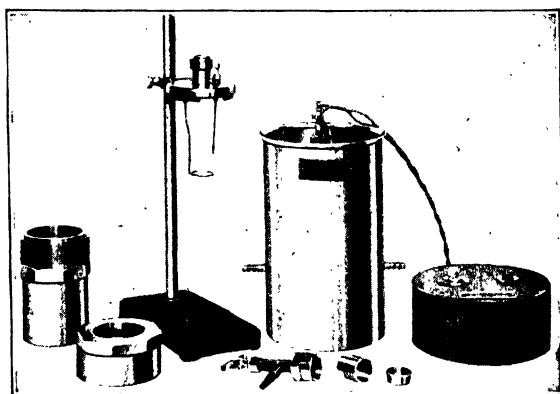

FIG. 83.—Bomb for sulfur determination in oils.

fusion cup. Now add about two-thirds of a measure, or 10 grams, of pure, sulfur-free sodium peroxide; then approximately 0.2 gram of benzoic acid, cover and mix thoroughly by shaking.

Now add the oil slowly and stir throughout the mass with a glass rod or platinum wire. When thoroughly mixed, add the remaining 5 grams of sodium peroxide on top without further mixing, put on the regular cover, seal with the screw cap, and proceed to ignite and to determine the sulfur as in the previous directions for coals.

(b) Oils having less than 0.5 per cent sulfur are not well adapted for use with the sodium peroxide method. However, from 1 to 1.5 grams of oil can be burned satisfactorily in the oxygen bomb, using 30 or 35 atmospheres of oxygen for a bomb capacity of 350 to 450 cc. A special assembly of an illium bomb

for sulfur determinations (Fig. 83) is available for carrying out the following procedure:¹

Place 22 cc. of distilled water in the bottom of the bomb. Then place a cup containing 0.6 to 0.8 gram of the oil, weighed accurately, in the bomb. Adjust the ignition fuse and close the bomb as previously described. Admit oxygen slowly to 30 to 35 atmospheres. Attach the leads from the firing circuit and ignite the bomb, surrounded by cold water. After 10 min. remove the bomb, open the valve and remove the bomb top. Rinse the bomb thoroughly, collecting the washings in a beaker. Filter the solution and wash the filter paper, allowing the washings to run into the filtrate. Add 2 cc. concentrated hydrochloric acid and 10 cc. of saturated bromine water and evaporate the filtrate to 75 cc. on a steam bath or hot plate. Determine the sulfur by one of the usual methods.

The apparatus shown in Fig. 83 is provided with a control box so that connection can be made directly to a 110-volt alternating-current circuit. The control box is provided with an ignition switch and should be maintained in the "on" position for about 3 to 5 sec. after which it is turned "off." The bucket arrangement provides for a continuous flow of cooling water.

Sulfur in Motor Fuels, Naphthas and Illuminating Oils by Lamp Method.—For volatile liquid fuels, which ordinarily contain a very low percentage of sulfur, the lamp method is usually recommended.² The procedure is as follows:

a. Pass two strands of new cotton wicking through the wick tube (see Fig. 84) so that they are not twisted but are parallel in the tube. Pour into the clean dry lamp about 15 cc. of the oil to be tested and insert the cork containing the wick tube. After the wick has become saturated with oil, trim it off as nearly as possible to the top of the tube and finally adjust by touching the top of it with the fingers. Weigh the oil and lamp assembly. Run a blank determination at the same time and under the same conditions by burning sulfur-free alcohol in a similar lamp. Thoroughly rinse out the absorber with distilled

¹ Am. Soc. Testing Materials, Method D 129-27, "Standard Methods," 1927, pt. 2, p. 419.

² Am. Soc. Testing Materials, Method D 90-30T, "Tentative Standards," 1930, p. 391.

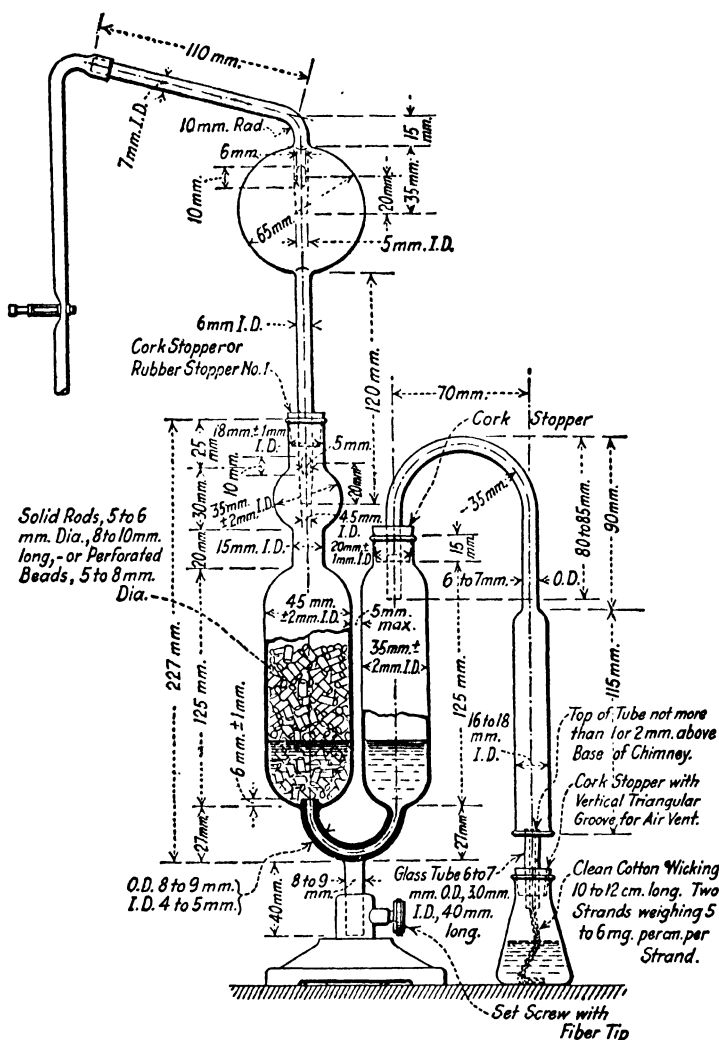

FIG 84.—Apparatus for determination of sulfur in volatile oils by lamp method. (From Amer. Soc. Testing Materials, Tentative Standards D 90-30T, p. 391, 1930.)

NOTE.—In the case of these dimensions for which no specific tolerances are designated above, the permissible variation is ± 10 per cent to the nearest millimeter, provided, however, that in no case the deviation be greater than 5 mm.

water and put into it exactly 10 cc. of sodium carbonate solution containing 3.306 grams Na_2CO_3 per liter of distilled water. Then dilute with 10 cc. of distilled water. Rinse out also the chimney and spray trap, dry the chimney and connect both to the absorber. Apply gentle suction to both absorbers; light both the oil lamp and the alcohol lamp and then place them in position under the chimneys so that the top of each wick tube extends into the chimney not more than 1 or 2 mm. above the edge. Use a sulfur-free flame such as an alcohol lamp for lighting the lamps. Adjust the suction so that a steady flame 12 to 18 mm. in height and free from smoking is obtained. The room should be free from draughts. The rate of oil consumption should be about 2 grams per hour, and the burning should continue for 1 to $1\frac{1}{2}$ hr.

b. Extinguish the flames, stop the suction and weigh the lamps. Disconnect the spray traps and chimneys and wash thoroughly with a methyl orange solution, collecting the washings in the absorber. Carefully titrate the solutions with a standard hydrochloric acid solution containing 2.275 grams of HCl per liter. If the methyl orange solution is red before the titration, too much oil has been burned and the determination should be repeated, using less oil.

From the volume of acid used calculate the amount of sodium carbonate neutralized and from this and the weight of oil burned calculate the percentage of sulfur in the oil. Make corrections for the sulfur found in the blank.

CHAPTER XXVII

THE ULTIMATE ANALYSIS OF COAL

SHORT METHOD

Introduction.—As a substitute for the elaborate and not always satisfactory ultimate analysis of coal, the following method will be found both convenient and accurate, fully meeting the requirements of the engineer in boiler-testing computations.

An ordinary combustion of the coal is made with sodium peroxide (Na_2O_2), in either the calorimetric bomb or the similar device described in Chapter XXVII for the determination of sulfur (Fig. 80). The sodium carbonate formed as a result of the combustion is then decomposed by an acid and the carbon dioxide collected and measured accurately for the determination of the carbon in the coal. Sulfate is then determined in the solution from the combustion by one of the standard methods. With a knowledge of the carbon and sulfur contents and thermal values of the fuel, the hydrogen, oxygen and nitrogen values may be very closely calculated for the "moisture-free" coal as follows:

1. Weight of sulfur $\times 5,000 =$ B.t.u. from sulfur as FeS_2
2. Weight of carbon $\times 14,545 =$ B.t.u. from carbon
3. Total determined B.t.u. $- (1 + 2) =$ B.t.u. from available hydrogen
4. $\frac{\text{B.t.u. from available hydrogen}}{62,000} =$ weight of available hydrogen
5. Nitrogen present may be assumed as a constant of 1.25 per cent
6. Then, by difference, $100 - (S + C + H + N + \text{ash as weighed}) =$
 $(O + H)^1$
7. $\frac{8}{9}(O + H) =$ total oxygen
8. $\frac{1}{9}(O + H) =$ combined hydrogen
9. Then, combined hydrogen + available hydrogen $(8 + 4) =$ total hydrogen.

¹ The expression $(O + H)$ refers to the total oxygen plus that amount of hydrogen necessary to combine with it to form water. This hydrogen is referred to as "combined hydrogen" to differentiate it from the "available hydrogen."

Total Carbon.—The percentage of total carbon in the coal may be obtained by utilization of the sodium peroxide fusion in which the total carbon of the coal has been oxidized and combined with chemical to form Na_2CO_3 . By liberating the CO_2 under accurately determined conditions as to temperature and pressure by

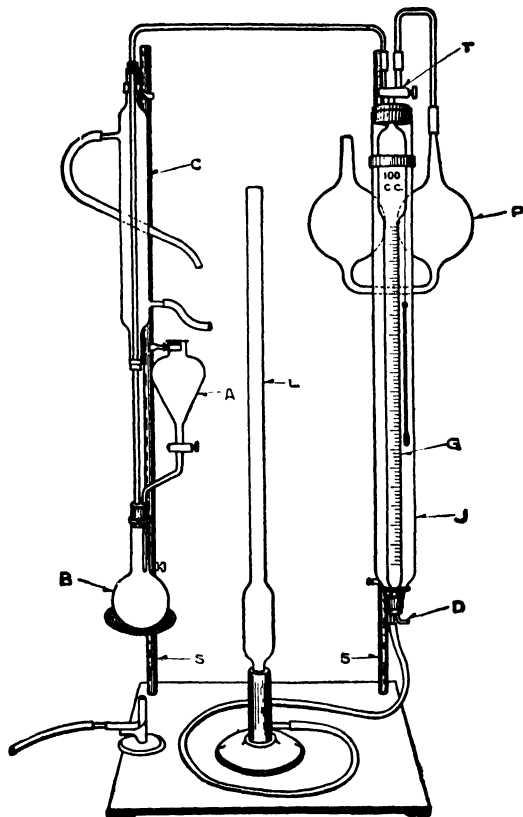

FIG. 85.—Total-carbon apparatus.

means of the apparatus shown in Fig. 85, the amount of carbon present may be derived from the volume of CO_2 discharged.

The total-carbon apparatus should be located on a laboratory desk or table where an even temperature can be maintained.

Fill the jacketing tube *J* with water slightly acidulated to keep it clear. Fill the leveling tube *L* with water that has had

2 or 3 cc. of sulfuric acid added. A few drops of methyl orange in the leveling tube will impart a color to the water, greatly facilitating the readings.

Connect the inlet *D* with air pressure and adjust so that two or three bubbles of air per second will enter the jacketing water. This is for the purpose of keeping the temperature of the water equalized throughout a determination. By reading the thermometer hung in the water, the temperature of the gas under observation is obtained.

The operation is as follows: The large double pipette *P* is half filled with 40 per cent solution of caustic potash, such as is ordinarily used for the absorption of CO_2 gas. By turning the three-way cock *T* to connect with the pipette *P* and lowering the leveling tube *L*, the liquid in *P* is brought into the right-hand bulb and made to rise in the capillary tube to the mark on the right limb of the capillary. The three-way cock is now closed to the pipette bulb and opened to the tube running to the flask *B*. By raising the leveling tube *L*, the liquid in the burette *G* is made to rise to the three-way cock *T*, thus completely filling the burette. The three-way cock is now closed to retain the liquid in the burette at the zero point, till evolution of the gas is begun.

The cup containing the fused material from a calorimetric determination is placed on its side in the bottom of a small beaker and covered with hot water that has been boiling for 5 or 10 min. Contamination with CO_2 from the water used or from contact with the air must be avoided as much as possible. When the fusion is dissolved, remove the cup, rinsing it well, and pour the solution directly into the flask *B*. Wash out the beaker thoroughly with hot water and pour the washings in with the main portion. Connect the flask with the funnel tube *A* and bring the ring support with wire gauze in place under the flask. Open the stopcock at the lower end of the funnel and boil the contents of the flask for 3 or 4 min. Remove the flame and at once close the funnel cock. In this way the oxygen from the sodium peroxide will be driven off together with the air in the flask. Also, when the three-way cock *T* is closed there will be a partial vacuum in the flask.

With the cock to the funnel tube *A* closed, enough acid is added to *A* to completely neutralize the alkaline solution in

B and leave a distinct excess of acid. Hydrochloric acid is preferred. Thirty cubic centimeters of concentrated hydrochloric acid will be found sufficient.

To start the reaction, lower the leveling tube *L*, open the three-way cock *T* to the tube connecting with the flask *B* and admit acid, drop by drop, from the funnel *A*. Meantime, the circulating water for the condenser *C* should be turned on.

When the evolution of the gas has about reached the capacity of the graduated burette *G* the acid is shut off, the three-way cock *T* closed and a reading of the volume of the gas carefully taken by bringing the two surfaces of liquid in the leveling tube and burette exactly on a level. Read also the temperature of the jacketing water and note the barometric pressure. The cock *T* is now opened to the capillary, and the gas volume forced completely over into the bulb *P* where it is held by closing the cock *T*. Here it is left for complete absorption of the CO_2 . The cock *T* may be again opened to connect with the flask *B*, the liquid in the burette *G* being at the zero point as before. The apparatus is now ready for a second evolution and measurement of a gas volume.

A second reading is similarly taken and the volume driven over into *P* as before, along with the former volume. Repeat the process until no more CO_2 is evolved.

Finally, heat is applied to the flask *B*, and after a few minutes boiling, hot water is added through the funnel *A*, until the solution is nearly up to the stopper, the flame of course being removed. At this point there should be no water remaining in the funnel *A*. Lower the leveling tube *L* to form a partial vacuum and allow air to be drawn through *A* into *B* and thus sweep out the residual gas in the connecting tubes into the burette *G*. The amount of air thus drawn in should be slightly more than the 100 cc. in the upper part of the burette so that after transferring to the bulb *P* for final absorption of the remaining CO_2 , the air returned to the graduated burette will be sufficient in amount to bring the level down upon the graduated portion of the burette for reading. The difference between this volume and the total of the several volumes is the total carbon dioxide present in the fusion.

By referring to Table XXX there is found at the observed temperature and pressure the weight in milligrams of carbon in

TABLE XXX.—WEIGHT OF CARBON PER CUBIC CENTIMETER OF CARBON DIOXIDE
(Calculated from 1.976 = Weight of 1 liter of CO₂ at 0°C., 760 mm., and 41 deg. latitude. Corrected for aqueous vapor,
barometer brass scale and deviation from gas law)

Temperature, °C.	Weight of carbon—milligrams per cubic centimeter of CO ₂ :													
	720 mm. Hg.	722 mm. Hg.	724 mm. Hg.	726 mm. Hg.	728 mm. Hg.	730 mm. Hg.	732 mm. Hg.	734 mm. Hg.	736 mm. Hg.	738 mm. Hg.	740 mm. Hg.	742 mm. Hg.	744 mm. Hg.	
10	0.4848	0.4862	0.4875	0.4889	0.4903	0.4917	0.4930	0.4944	0.4958	0.4972	0.4985	0.4999	0.5013	
11	0.4826	0.4839	0.4853	0.4867	0.4880	0.4894	0.4908	0.4921	0.4934	0.4948	0.4962	0.4976	0.4990	
12	0.4803	0.4817	0.4830	0.4844	0.4858	0.4871	0.4885	0.4899	0.4912	0.4926	0.4940	0.4953	0.4967	
13	0.4780	0.4794	0.4807	0.4821	0.4835	0.4848	0.4862	0.4875	0.4889	0.4902	0.4916	0.4930	0.4943	
14	0.4757	0.4771	0.4784	0.4798	0.4812	0.4825	0.4839	0.4852	0.4866	0.4879	0.4893	0.4906	0.4920	
15	0.4734	0.4748	0.4761	0.4775	0.4788	0.4802	0.4815	0.4829	0.4842	0.4856	0.4869	0.4883	0.4896	
16	0.4711	0.4725	0.4738	0.4752	0.4765	0.4779	0.4792	0.4806	0.4819	0.4832	0.4846	0.4859	0.4873	
17	0.4688	0.4701	0.4715	0.4728	0.4742	0.4755	0.4769	0.4782	0.4795	0.4809	0.4822	0.4835	0.4849	
18	0.4664	0.4678	0.4691	0.4704	0.4718	0.4731	0.4745	0.4758	0.4771	0.4785	0.4798	0.4811	0.4825	
19	0.4641	0.4654	0.4667	0.4681	0.4694	0.4707	0.4721	0.4734	0.4747	0.4760	0.4774	0.4787	0.4800	
20	0.4617	0.4631	0.4644	0.4657	0.4670	0.4683	0.4697	0.4710	0.4723	0.4736	0.4749	0.4763	0.4776	
21	0.4593	0.4606	0.4619	0.4633	0.4646	0.4659	0.4672	0.4685	0.4699	0.4712	0.4725	0.4738	0.4751	
22	0.4569	0.4582	0.4595	0.4608	0.4622	0.4635	0.4648	0.4661	0.4674	0.4687	0.4700	0.4713	0.4727	
23	0.4544	0.4557	0.4570	0.4583	0.4597	0.4610	0.4623	0.4636	0.4649	0.4662	0.4675	0.4688	0.4701	
24	0.4519	0.4532	0.4545	0.4558	0.4572	0.4585	0.4598	0.4611	0.4624	0.4637	0.4650	0.4663	0.4676	
25	0.4494	0.4508	0.4520	0.4533	0.4547	0.4560	0.4572	0.4585	0.4598	0.4611	0.4624	0.4637	0.4650	
26	0.4468	0.4481	0.4494	0.4507	0.4520	0.4533	0.4546	0.4559	0.4572	0.4585	0.4598	0.4611	0.4624	
27	0.4442	0.4455	0.4468	0.4481	0.4494	0.4507	0.4520	0.4533	0.4545	0.4558	0.4571	0.4584	0.4597	
28	0.4416	0.4429	0.4442	0.4455	0.4468	0.4481	0.4493	0.4506	0.4519	0.4532	0.4545	0.4557	0.4571	
29	0.4390	0.4403	0.4416	0.4429	0.4442	0.4454	0.4467	0.4480	0.4493	0.4505	0.4518	0.4531	0.4544	
30	0.4364	0.4377	0.4390	0.4403	0.4415	0.4428	0.4441	0.4453	0.4466	0.4479	0.4492	0.4504	0.4517	
31	0.4337	0.4350	0.4362	0.4375	0.4388	0.4400	0.4413	0.4426	0.4438	0.4451	0.4464	0.4476	0.4489	
32	0.4310	0.4322	0.4335	0.4347	0.4360	0.4373	0.4385	0.4398	0.4410	0.4423	0.4436	0.4449	0.4461	
33	0.4281	0.4293	0.4306	0.4319	0.4331	0.4344	0.4356	0.4369	0.4381	0.4394	0.4407	0.4419	0.4432	
34	0.4252	0.4265	0.4277	0.4290	0.4302	0.4315	0.4328	0.4340	0.4353	0.4365	0.4378	0.4390	0.4403	
35	0.4224	0.4236	0.4249	0.4261	0.4274	0.4286	0.4299	0.4311	0.4324	0.4336	0.4349	0.4361	0.4374	

TABLE XXX.—WEIGHT OF CARBON PER CUBIC CENTIMETER OF CARBON DIOXIDE.—(Continued)

Temperature, °C.	Weight of carbon—milligrams per cubic centimeter of CO ₂													
	746 mm. Hg.	748 mm. Hg.	750 mm. Hg.	752 mm. Hg.	754 mm. Hg.	756 mm. Hg.	758 mm. Hg.	760 mm. Hg.	762 mm. Hg.	764 mm. Hg.	766 mm. Hg.	768 mm. Hg.	770 mm. Hg.	
10	0.5027	0.5040	0.5054	0.5068	0.5082	0.5096	0.5109	0.5123	0.5137	0.5150	0.5164	0.5178	0.5192	
11	0.5004	0.5017	0.5031	0.5045	0.5058	0.5072	0.5086	0.5100	0.5113	0.5127	0.5140	0.5154	0.5168	
12	0.4980	0.4994	0.5008	0.5021	0.5035	0.5049	0.5062	0.5076	0.5089	0.5103	0.5117	0.5130	0.5144	
13	0.4957	0.4970	0.4984	0.4998	0.5011	0.5025	0.5038	0.5052	0.5066	0.5079	0.5093	0.5106	0.5120	
14	0.4933	0.4947	0.4960	0.4974	0.4988	0.5001	0.5015	0.5028	0.5042	0.5055	0.5069	0.5082	0.5096	
15	0.4910	0.4923	0.4937	0.4950	0.4964	0.4977	0.4991	0.5004	0.5018	0.5031	0.5045	0.5058	0.5072	
16	0.4886	0.4899	0.4913	0.4926	0.4940	0.4953	0.4967	0.4980	0.4994	0.5007	0.5020	0.5034	0.5047	
17	0.4862	0.4876	0.4889	0.4903	0.4916	0.4929	0.4943	0.4956	0.4969	0.4982	0.4996	0.5009	0.5022	
18	0.4838	0.4851	0.4865	0.4878	0.4892	0.4905	0.4918	0.4931	0.4944	0.4958	0.4971	0.4984	0.4998	
19	0.4814	0.4827	0.4840	0.4854	0.4867	0.4880	0.4893	0.4907	0.4920	0.4933	0.4946	0.4959	0.4973	
20	0.4789	0.4803	0.4816	0.4829	0.4842	0.4856	0.4869	0.4882	0.4895	0.4908	0.4922	0.4935	0.4948	
21	0.4764	0.4778	0.4791	0.4804	0.4817	0.4830	0.4844	0.4857	0.4870	0.4883	0.4896	0.4909	0.4923	
22	0.4740	0.4753	0.4766	0.4779	0.4792	0.4805	0.4818	0.4832	0.4845	0.4858	0.4871	0.4884	0.4897	
23	0.4714	0.4727	0.4740	0.4754	0.4767	0.4780	0.4793	0.4806	0.4819	0.4832	0.4845	0.4858	0.4871	
24	0.4688	0.4702	0.4715	0.4728	0.4741	0.4754	0.4767	0.4780	0.4793	0.4806	0.4819	0.4832	0.4845	
25	0.4663	0.4676	0.4689	0.4702	0.4715	0.4728	0.4741	0.4754	0.4767	0.4780	0.4793	0.4806	0.4819	
26	0.4637	0.4650	0.4662	0.4676	0.4688	0.4701	0.4714	0.4728	0.4740	0.4753	0.4766	0.4779	0.4792	
27	0.4610	0.4623	0.4636	0.4649	0.4662	0.4674	0.4687	0.4700	0.4713	0.4726	0.4739	0.4752	0.4765	
28	0.4583	0.4596	0.4609	0.4622	0.4635	0.4647	0.4660	0.4673	0.4686	0.4699	0.4712	0.4724	0.4737	
29	0.4557	0.4569	0.4582	0.4595	0.4608	0.4620	0.4633	0.4646	0.4659	0.4672	0.4685	0.4697	0.4710	
30	0.4530	0.4543	0.4556	0.4568	0.4581	0.4594	0.4606	0.4619	0.4632	0.4645	0.4657	0.4670	0.4683	
31	0.4502	0.4515	0.4527	0.4540	0.4553	0.4566	0.4578	0.4591	0.4604	0.4616	0.4629	0.4641	0.4654	
32	0.4474	0.4487	0.4499	0.4512	0.4524	0.4537	0.4550	0.4562	0.4574	0.4588	0.4600	0.4613	0.4626	
33	0.4445	0.4457	0.4470	0.4482	0.4495	0.4508	0.4520	0.4533	0.4545	0.4558	0.4571	0.4583	0.4596	
34	0.4415	0.4428	0.4441	0.4453	0.4466	0.4478	0.4491	0.4503	0.4516	0.4529	0.4541	0.4554	0.4566	
35	0.4386	0.4399	0.4412	0.4424	0.4437	0.4449	0.4461	0.4474	0.4487	0.4499	0.4512	0.4524	0.4537	

1 cc. of CO_2 gas.¹ Multiply this weight by the number of cubic centimeters obtained in the above operation and the product equals the weight in milligrams of pure carbon. From this should be subtracted the weight of carbon found by running a blank in exactly the same manner, using one measure of the sodium peroxide instead of the fusion.

After subtracting the blank, the carbon remaining represents the total carbon present in the fuel. Divide this number by the weight of fuel taken and multiply by 100. The product is the percentage of carbon present in the sample taken.

Coals with calcium carbonate present should have the CO_2 in that combination determined and the total carbon factor corrected accordingly. Five grams of coal should be put into the flask and treated precisely as for a fusion. The amount of carbon found from the volume of CO_2 liberated is subtracted from the total carbon as obtained from the fusion. This, of course, is in addition to the CO_2 found in the blank determination in the Na_2O_2 .

Sulfur.—The combustion of coal by means of sodium peroxide affords a convenient method for the determination of sulfur by reason of the fact that the oxidizing conditions are so pronounced as to insure the complete transformation of all of the sulfur to the sulfate form. This is accomplished in a very few minutes and without possible contamination by accession of sulfur from external sources, as where city gas is employed in the ordinary process. A description of the method has already been given in Chapter XXVII.

Hydrogen.—The hydrogen is determined by calculation as already discussed. At this stage it is well to transfer the factors involved to the unit coal basis. Calculate the B.t.u. for unit coal. Calculate also the percentage of total carbon present in the unit coal, exclusive, of course, of any carbon present as calcite. Find the available heat from the total carbon (C by 14,545, in which C is the percentage of carbon in the unit coal). The remaining heat is due to the combustion of the available

¹ See also PARR, S. W., The weight of carbon dioxide with a table of calculated values: *Jour. Am. Chem. Soc.*, vol. 21, p. 237, 1909; PARR, S. W. and KING, W. F., JR., The density of carbon dioxide with a table of recalculated values: *Univ. Ill. Eng. Expt. Sta., Circ.* 13, 1926.

hydrogen. Divide this remainder by 62,000, the accepted value for hydrogen. The result is equal to the percentage of hydrogen, H .

Oxygen.—Assuming a value in the unit coal for nitrogen of 1.25 per cent, we would have the residual constituents, R consisting of oxygen and the hydrogen combined as H_2O represented by the expression $R = 100 - (C + H + N)$.

In the value thus found for R , the combined hydrogen would be one-ninth and the oxygen eight-ninths of that value.

The values thus obtained on unit coal are to be calculated back to the "dry" by multiplying each value by 1 minus the ash corrected for hydration and sulfur.

CHAPTER XXIX

FUEL-GAS ANALYSIS

All of the many industries engaged in producing fuel or utilizing it in any way find that analysis is an essential accompaniment to their work. In the operation of gas producers, the percentage of carbon monoxide, carbon dioxide, oxygen, hydrogen and hydrocarbons must be determined. The same determinations must be made for by-product coke-oven gas, retort gas, water gas, carbureted water gas and natural gas. When gas is sold to consumers a complete check on the heat value and composition of the gas is sometimes necessary. The analysis must be made rapidly and accurately for it is used in controlling industrial operations and determining their efficiency, as well as to indicate to the consumer what he is buying.

An examination of the constituents present in various gases shows that, while there are large variations in the percentage composition, the constituents themselves are quite uniform as to kind. For this reason it is possible and often convenient to assemble in one apparatus the individual units for making the several determinations. Moreover, portability is not an essential feature for such work; hence the development of what may be properly referred to as an enlarged Orsat apparatus for making a complete analysis of any of the various types of fuel gases. Such an apparatus is shown in Fig. 86.

The apparatus and methods described here are not capable of precision results but are entirely suitable for control analysis. Check determinations may be expected to give readings consistently within 0.3 per cent of one another. Some errors may be caused in the analysis due to absorption or liberation of constituents, notably carbon dioxide, by the confining salt solution. These errors may be eliminated by using mercury as the confining liquid, in which case it is recommended that the companion burette be replaced with a manometer compensator.

For more exact fuel-gas analysis the U. S. Bureau of Standards modification of the Orsat apparatus is suggested.¹ Additional information on gas analysis and methods of analyzing special gases may be found in the following references: "Gas Analysis"

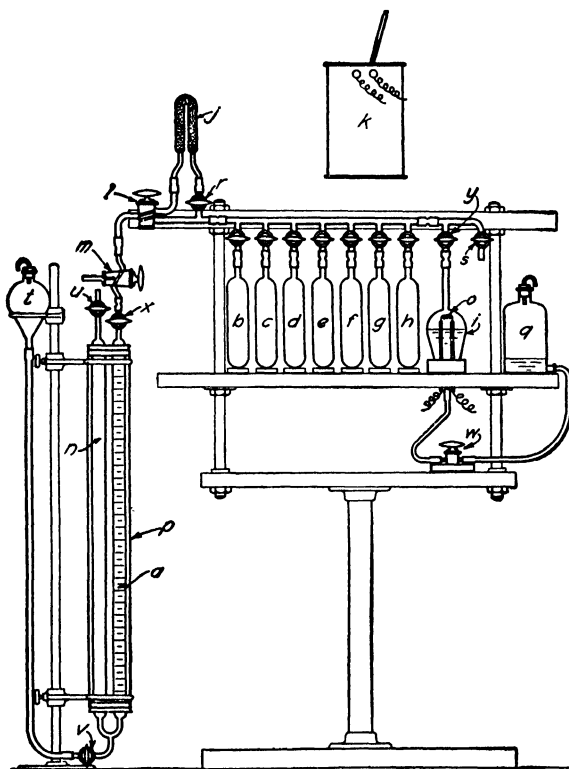

FIG. 86.—Modified Orsat apparatus for fuel-gas analysis.

by Dennis;² "Methods of the Chemists of the United States Steel Corporation for the Sampling and Analysis of Gases";³ "The Analysis of Fuel Gas" by Parr and Vandever;⁴ and

¹ SHEPPARD, M., An improved apparatus and method for the analysis of gas mixtures by combustion and absorption: U. S. Bur. Standards, *Jour. of Research*, vol. 6, p. 121, 1931.

² The Macmillan Company, New York, 1929.

³ Carnegie Steel Company, 3d ed., 1927.

⁴ Univ. Ill. Eng. Expt. Sta., *Circ.* 12, 1924.

“Sampling and Examination of Mine Gases and Natural Gas” by Burrell, Seibert and Jones.¹

Apparatus.—The gas-analysis apparatus is a modified Orsat design of conventional construction. The frame is of gas pipe and wood. The measuring burettes and absorption pipettes are standard items of glass ware. The manifold stopcock assembly, copper oxide furnace and combustion pipette are easily assembled by any one with ability in working pyrex glass. Figure 86 shows the apparatus with seven absorption pipettes. Three are all that are necessary in ordinary fuel-gas analysis, although a fourth is often appreciated as a convenience in handling and storing the sample. The additional pipettes when available are used for special reagents which may be required in analyzing some gases.

The apparatus consists of a graduated burette *a* and a blank companion burette *n*, which are connected by means of a Y-tube at the lower end. These are connected to the leveling bulb *t*. With this arrangement the sample is measured at atmospheric pressure before the analysis is begun and also after the removal of each constituent. The burettes and leveling bulb are filled with a saturated salt solution which may be slightly colored, if desired, with some inorganic salt as nickel nitrate, to aid in reading the meniscus level. The jacket *p* surrounding these two burettes is filled with water slightly acidulated to keep it clear. The other essential items of the apparatus are the absorption pipettes *b-h*, the copper oxide tube *j* and the slow-combustion pipette *i*. These are connected to the measuring burette by means of a manifold of capillary glass tubing and stopcocks, this being divided into three parts, as is shown by the figure, to facilitate manufacture, assembling and, when necessity demands, repairing. All stopcocks through which gas is passed should have the plug or core bored at an angle, and must be kept well lubricated with a good stopcock grease. Care must also be taken not to pull the reagents in the pipettes up into the stopcocks as this will cause them to stick; this is especially true of the alkaline reagents and, if such a mistake is made, the stopcocks must be carefully cleaned and greased at once. The absorption pipettes are the same as those used in the

¹ U. S. Bur. Mines, *Bull.* 197, 1926.

ordinary Orsat flue-gas-analysis outfits and have the chamber into which the gas is drawn filled with glass tubes to increase the surface and obviate the necessity of shaking.

The so-called copper oxide furnace is an ordinary chromel-wire resistance furnace, wound on an alundum core, insulated with Sil-o-Cel and contained in a metal jacket. Forty feet of No. 24 chromel wire makes a satisfactory heating element. The current for such an element is taken from the 110-volt alternating-current lighting circuit which may be connected directly without danger of burning out the element. This, however, will heat the furnace higher than is desired and it is necessary to connect a lamp bank or other resistance in series with the heating element in order to maintain the desired temperature. The furnace *k* is placed over the pyrex U-tube *j*. The U-tube is filled completely with copper oxide that has been ground to pass through a 20-mesh sieve and is retained by a 40-mesh sieve. The oxide is revived from time to time by passing oxygen through it while it is at the reactive temperature of 300°C.

The slow combustion pipette *i* may be made from a 300-cc. pyrex Kjeldahl digesting flask. It is connected to the manifold with a small capillary tube which must be carefully sealed on, so that the orifice is no larger than the bore of the tubing. This will cause the gas to enter the pipette in a small jet and eliminate the liability of explosive mixtures during the manipulation of the pipette. The bottom of the pipette is closed with a three-hole rubber stopper which accommodates, besides the outlet of the pipette, two glass tubes at the inner ends of which is sealed a platinum coil *o*. This coil is placed about $\frac{1}{2}$ in. below and slightly to one side of the opening of the capillary tube. It is connected in series with a variable resistance (not shown in the figure). The outlet from the pipette connects, by means of rubber tubing and the stopcock *w*, with the small aspirator bottle *q*. Mercury is used in this part of the apparatus instead of salt water.

Oxygen and nitrogen are used during the procedure of the analysis. These are kept at hand in large aspirator bottles over water and are connected permanently with the apparatus by means of rubber tubing. The stopcock *s* connects with the nitrogen bottle, and *m* with the oxygen bottle. The sample of

gas is usually collected and stored in one of the conventional gas-sampling tubes or over saturated salt water in a small aspirator bottle and is drawn from this into the burette *a*, through a rubber tube connected to the stopcock *x*, which has a key extension for the rubber tubing, similar to that of stopcock *m*.

Manipulation and Description of Reagents.—Before beginning an analysis, make sure that none of the stopcocks leak or otherwise need attention, and that the levels of the solutions in all of the pipettes are up to the marks. Next sweep the manifold and copper oxide tube thoroughly with nitrogen, drawing it in through the stopcock *s*, and expelling it through the stopcock *x*. It is also well to have brought the copper oxide furnace up to the required temperature of 300° before the analysis is begun and to have made sure that the nitrogen enclosed in it is at atmospheric pressure. Otherwise, due to expansion, there will be a slight change in the reading on the burette when the stopcocks *l* and *r* are opened during the analysis, which will probably be overlooked and which will cause an error in the hydrogen determination. Having observed the above precautions and having the burette *a* filled completely up to the stopcock *x* with salt solution, the sample bottle is connected with the stopcock *x*, by means of a rubber tube that has been thoroughly flushed with the gas to be analyzed. A sample of slightly over 100 cc. is drawn into the burette. The companion tube *n* is vented to the atmosphere by opening stopcock *u*, and the solution in it is allowed to come to the same level as in the bulb *t*, which should be slightly below the level of the 100 cc. graduation on the burette *a*. Without closing the stopcock *x*, the rubber tube is disengaged from the sample bottle, but not from the stopcock, and the bulb *t* is raised until the solution in it and the two burettes are at the same level and at the 100-cc. mark in the burette *a*. The stopcocks *x* and *u* are now closed and the burette *a* contains exactly 100 cc. of the gas at atmospheric pressure. Since all other parts of the apparatus are filled with the inert gas, nitrogen, and since all future volume readings during this analysis will be made at the same pressure, the contractions will all be on the basis of the 100-cc. sample at atmospheric pressure and will be in per cent by volume. It is

assumed that the atmospheric pressure will not change during the short time required for the analysis. No corrections for humidity need to be made on account of the gas being saturated with water vapor. During the analysis the leveling bulb *t* is held in the left hand and, when raised or lowered, the gas is forced into the various pipettes or drawn back into the burette *a*. In measuring the sample during the analysis, the stopcock *u* is opened and, with the aid of the leveling bulb, the solutions in burettes *a* and *n* are brought to the same level. The stopcock *v* is now closed and the volume read on the burette *a*. This volume is written down at once and the analysis continued by closing the stopcock *u*, opening *v* and, with the aid of bulb *t*, forcing the sample into the next desired portion of the apparatus.

Carbon Dioxide.—Now that the burette contains a sample of exactly 100 cc. of gas, the next step is the removal of the constituent, carbon dioxide. The first pipette *b* contains about 150 cc. of 40 per cent KOH. Potassium hydroxide is preferred rather than sodium hydroxide because it is a faster reagent and also has a greater capacity for carbon dioxide. It retains its activity even after it shows considerable carbonate precipitate. The stopcocks *x*, *m* and *l* and the one at the top of the pipette *b* are opened so that, by raising the leveling bulb *t*, the gas in burette *a* will be driven into the pipette. The gas is forced from *a* to *b*, and back, several times (usually five will be sufficient), until it shows no further reduction in volume. The difference between this final constant volume and the original 100 cc. will be the percentage of carbon dioxide in the sample. It might be well to note that if the gas contains hydrogen sulfide, it will also be removed by the KOH and thus give a slight error in the carbon dioxide value. This gas may be determined, when in sufficient quantity, by passing the gas sample first into a pipette filled with a solution of arsenious acid. In this case the removal of carbon dioxide would come second in the procedure.

Illuminants.—These consist of a mixture of unsaturated hydrocarbons and benzene vapor. They are removed by passing the sample (now free of CO₂) several times into pipette *c*, which is filled with 20 per cent fuming sulfuric acid. After obtaining a constant volume, the gas sample must be again passed into the KOH pipette *b*, to remove SO₃ fumes before the volume may be

read and the percentage of illuminants determined by the difference between this volume and the volume after removing CO_2 .

Oxygen.—Oxygen is next removed by passing the sample several times into the pipette *d*, which contains an alkaline solution of pyrogallol, made by mixing equal volumes of 33 per cent KOH and 25 per cent pyrogallic acid. One volume of this reagent is able to absorb about eight volumes of oxygen. The reagent will deteriorate quite rapidly if exposed to the air and it is well to connect the secondary pipette with a small rubber balloon or to cover the solution with a $\frac{1}{4}$ -in. layer of paraffin oil to prevent deterioration. It is also desirable to protect the KOH and fuming H_2SO_4 solutions in the same manner. After removal of all the oxygen, the volume of the gas is taken. The difference between this volume and the volume after removing the illuminants is the percentage of oxygen in the sample of gas.

Hydrogen and Carbon Monoxide.—This concludes the absorption methods in the ordinary analysis and the next step is the determination of hydrogen and carbon monoxide by use of the copper oxide furnace, already described. It is assumed that this furnace is at a temperature of 300°C . and that the enclosed nitrogen is at atmospheric pressure, this having been attended to at a previous time. The stopcocks *l* and *r* are turned to bring the U-tube *j* in series with the rest of the manifold and the gas sample is forced through the U-tube and into the pipette *e*. This pipette is filled with saturated salt solution and does not necessarily need to be filled with glass rods as it merely acts as a reservoir for the gas sample. On passing the gas through the hot copper oxide, combustion of the hydrogen and carbon monoxide takes place, the former burning to water and condensing out, while the latter burns to carbon dioxide and remains in the sample, but occupies the same space as did the carbon monoxide. Thus the contraction in volume is due entirely to the removal of the hydrogen from the sample of gas and, if the sample is passed back and forth through the copper oxide until its volume becomes constant, the contraction will give directly the percentage of hydrogen that was originally in the sample. As the reactive temperature of carbon monoxide with copper oxide is lower than that of hydrogen (see Table XXXI), it may be assumed that when all of the hydrogen has been removed, all

TABLE XXXI.—COMBUSTION TEMPERATURES FOR GASES IN CONTACT WITH COPPER OXIDE¹

Gas	Reacting Temperatures with Pure CuO, °C. (Campbell)
CO.....	100 to 105
H ₂	175 to 180
C ₃ H ₆	270 to 280
C ₂ H ₄	315 to 325
C ₄ H ₈	320 to 330
CH ₄	650 to 750 in air

¹ From CAMPBELL, *Jour. Am. Chem. Soc.*, vol. 17, p. 688, 1895; refer also to Jäger, *Jour Gasbeleucht.*, vol. 41, p. 764, 1898.

of the carbon monoxide will be burned to carbon dioxide. After reading the volume and determining the percentage of hydrogen in the gas, sufficient nitrogen, usually about 15 cc., is drawn in through the stopcock *s*, to completely sweep the tube *j* of any of the sample. The gas in the burette is placed at atmospheric pressure and the stopcocks *l* and *r* are returned to their original position. The volume of the sample which is now increased, due to the added nitrogen, is read and noted as "new volume." The sample is now forced into the pipette *b* several times to remove the carbon dioxide resulting from the burning of the carbon monoxide. The resultant volume is read and the difference between this volume and the last-read or "new volume" gives directly the percentage of carbon monoxide that was present in the gas.

Methane and Ethane.—The sample of gas now contains presumably nothing but methane, ethane and nitrogen, although there probably are instances where some of the higher paraffin homologues are present. The amounts of paraffins are determined by burning in an atmosphere of oxygen in the slow combustion pipette *i*, the ignition being caused by the electrically heated platinum coil *o*. The mechanics of the determination are as follows: Store the sample temporarily in the pipette *e*. Draw 90 to 100 cc. oxygen into the burette *a* through the stopcock *m*, measure the volume at atmospheric pressure and then force it into the combustion pipette *i*. This volume of oxygen is sufficient to burn 30 to 50 cc. of the sample, depending upon the amounts of methane and ethane present. To insure sufficient

excess of oxygen during the combustion, draw approximately 20 cc. of the sample from pipette *e* into the burette and read the volume. Use this portion of the sample for a combustion and keep the remainder for a check if desired. Place the sample under slight pressure by putting the bulb *t* in the upper holder as shown in the figure. The level of the mercury in the pipette *i* will be below the tips of the glass rods. The stopcock *w* is open and the mercury level in the bottle *q* is slightly lower than in the combustion pipette *i*, thus giving a slight vacuum in the pipette. The stopcock *y* in the manifold leading to the pipette *i* is closed. Next heat the platinum coil to a bright-red or almost white heat with the electric current. It is now time to admit the sample from the burette. Carefully open the stopcock *y* slightly, and do not let go of it, thus controlling the flow of gas into the pipette. It should burn at once with a small luminous jet from $\frac{1}{4}$ to $\frac{3}{8}$ in. in length and not directed upon the platinum coil. Watch carefully the flow of the gas from the burette *a* and, when the burette is full of water, close the stopcock *y* from which the hand has not been removed. Immediately turn off the electric current. If the above directions are not carefully followed, a dangerous explosion may occur when the attempt is made to burn the paraffins.¹ The hydrocarbon gas, C_nH_{2n+2} , in the sample has burned to water and carbon dioxide. The water has condensed out and may be seen on the surface of the mercury. It is forced up the capillary tube when the resultant gas is withdrawn from the pipette *i* and finds its way, usually, into the adjacent pipettes by settling into the vertical tubing above the stopcocks. No special attention is given to the elimination of the water from the pipette *i*, but it is the usual practice to bring the level of the mercury up to the stopcock *y* after each determination and thus the water in the pipette is maintained at a minimum.

It is now necessary to measure the volume of gas in the combustion pipette and determine the carbon dioxide that it contains. First, place the level of the mercury in the bottle *q* above that in the pipette *i*, thus preventing the salt solution in the burette *a* being pulled over when the stopcock *y* is opened. Measure the

¹ Due to the possibility of an explosion in the combustion pipette it is advisable to use a small pane of "safety glass" in front of the pipette.

resultant gas, pass it into the pipette *b* to remove the carbon dioxide and measure the volume a second time. From the readings taken during the procedure, as just described, four values are available. These are: (1) the volume of the gas sample burned; (2) the volume of oxygen taken; (3) the volume of the resultant gas after combustion; and (4) the volume of carbon dioxide in the resultant gas. The contraction, due to the condensation of water, is obtained by subtracting (3) from the sum of (1) and (2). By substituting these values in a formula derived from the chemical equations of the reaction we have:

$$\frac{2 \times \text{contraction} - \text{CO}_2}{3} = \text{volume of } \text{C}_n\text{H}_{2n+2} \text{ (the paraffins)}$$

The value for *n*, or the index of the relative amounts of ethane and methane, will be found to be: $n = \text{CO}_2/\text{volume}$. If $n = 1$, the entire volume is methane (CH_4); if $n = 2$, the entire volume is considered ethane (C_2H_6); if $n = 1.3$, then 0.3 of the volume of the hydrocarbons is ethane and 0.7 methane; if $n = 1.6$, then 0.6 of the volume is ethane and 0.4 methane, etc. Since only a fraction of the gas left after the removal of hydrogen was taken for combustion, the volume of methane and ethane found must be multiplied by a/b , where *a* is the total volume of the gas stored in the pipette *e* after the removal of the hydrogen, and *b* is the volume of that part of the gas taken for combustion. This gives the percentages of methane and ethane in the 100 cc. of gas taken for the analysis.

Nitrogen.—The sum of the percentages of the constituents so far determined should not be 100. The difference between their sum and 100 therefore is taken as the percentage of nitrogen in the original sample. This nitrogen value, since it is obtained by difference, must of course carry all of the errors of the several determinations. Experience would seem to indicate, however, that these are small in amount.

Of the seven absorption pipettes, only four are used in the ordinary analysis. The extra pipettes are included in the apparatus for additional reagents that may be needed in case of analyzing special gases. For example, it may be desired to fill a pipette with arsenious acid for the removal of hydrogen sulfide, or the gas may contain acetylene which can be removed directly

after oxygen by passing into a pipette filled with ammoniacal silver chloride.¹ The ammonia fumes must be removed by passing the gas into a pipette of weak sulfuric acid before the reading is taken.

It is sometimes desirable to remove oxygen from the gas by means of yellow phosphorus instead of with pyrogallol solution. This is especially true when the percentage is rather high, on account of the relatively small capacity of the pyrogallol. The phosphorus in the form of small sticks is placed in the pipette, instead of the glass rods, and is covered with water. On passing the gas to be analyzed into the phosphorus pipette, the oxygen unites with the phosphorus, forming solid oxides of phosphorus. When phosphorus is used to remove oxygen, the gas must be entirely freed from illuminants, as these will poison the phosphorus and make it inactive. Phosphorus is considered a very good reagent for oxygen, but its use in the apparatus in the author's laboratory has been rather unsatisfactory on account of its being affected by light, its ease of being poisoned and its slowness of reaction.

In case the extra pipettes are not filled with special reagents, it is well to fill them with saturated salt solutions as they may often be used as storage reservoirs for samples of gas to be analyzed.

Derivation of Calculations.—The formulas for determining the percentages of hydrocarbons from their combustion with oxygen are derived from the combustion equation as follows:

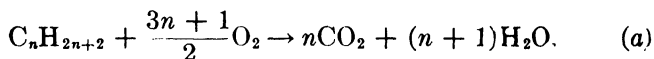

From (a) the contraction is determined as

$$\begin{aligned} C &= V + \frac{(3n+1)V}{2} - nV & (b) \\ C &= \frac{2V + 3nV + V - 2nV}{2} \\ C &= \frac{nV + 3V}{2} \end{aligned}$$

¹ WHITE, A. H., "Technical Gas and Fuel Analysis," p. 85: McGraw-Hill Book Company, Inc., New York, 1920.

From (b)

$$nV = 2C - 3V \quad (c)$$

also from (a)

$$nV = CO_2 \quad (d)$$

By solving the two equations (c) and (d)

$$V = \frac{2C - CO_2}{3} \quad (e)$$

Then from (d)

$$n = \frac{CO_2}{V} \quad (f)$$

The value V is the correct volume of the hydrocarbon gas no matter how many of the homologues are present and in like manner the value n is the average composition of the mixture. If methane were the only homologue present, the value for n would be unity. Also if ethane were the only constituent the value of n would be 2. This may be proven by solving for n from the equations

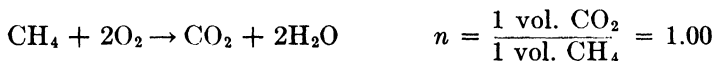

and

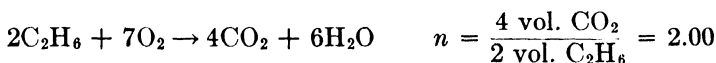

It is very seldom that a value for n of more than 2 is obtained and though this does not mean that there are none of the homologues higher than ethane present in the gas, it does show that methane and ethane predominate. The volume of hydrocarbons is usually considered as being only methane and ethane and is differentiated into these two by applying the portion of n greater than unity as a factor which when taken times the volume V will give the volume of ethane. Methane will then be V minus ethane and the volumes of these two constituents as determined will be reported in per cent on the basis of the original sample of gas.

An analysis with calculations is given in Table XXXII to show the recommended method of recording the data as taken and also to serve as an example of the calculations which are required.

TABLE XXXII.—A TYPICAL COAL-GAS ANALYSIS ILLUSTRATING CALCULATIONS FOR PARAFFINS

Constituents	Volume, 100 cc.	Per cent	Calculations
Carbon dioxide.....	98.4	1.6	$V = \frac{2C - CO_2}{3}$ $n = \frac{CO_2}{V}$ $\text{Per cent} = \frac{a}{b} \times V$ $V = \frac{40.4 - 10.4}{3} = 10.0$ $n = \frac{10.4}{10} = 1.04$ $\text{Per cent} = \frac{50.5}{18.2} \times 10 = 27.7$ $27.7 \times 0.04 = 1.1$
Illuminants.....	93.6	4.8	
Oxygen.....	92.4	1.2	
Hydrogen.....	46.1	46.3	
New volume-adding nitrogen .	58.9		
Carbon monoxide.....	50.5	8.4	
Oxygen added.....	99.8		
Gas taken.....	18.2		
Total.....	118.0		
After combustion.....	97.8		
Contraction.....	20.2		
After potassium hydroxide...	87.4		
Carbon dioxide formed.....	10.4		
Methane.....		26.6	
Ethane.....		1.1	
Nitrogen.....		10.0	
Total.....		100.0	

Sulfur.—Sulfur occurs in manufactured gas mainly as hydrogen sulfide (H_2S). Carbon and hydrocarbon compounds of sulfur are usually present, but in much smaller amount. In coal gas, ordinarily about 85 per cent of these compounds are carbon bisulfide and the remainder are thiophens and mercaptans. It is not easy to prescribe a limit for sulfur, owing to the wide variations both in operating conditions and in the type of materials which must be used in gas manufacture. The U. S. Bureau of Standards¹ recommends a limit of 30 grains of total sulfur per cubic foot of gas. Whatever the form in which sulfur occurs, in the process of combustion it burns to SO_2 and SO_3 . The presence of more than a trace of H_2S shows carelessness in the manufacturing process.

A widely used quantitative method for *hydrogen sulfide* involves titration of the gas with a standard iodine solution, using starch as an indicator. The Tutwiler burette (Fig. 87) is used in the

¹ Standards of gas service: U. S. Bur. Standards, *Circ.* 32, p. 101, 1915.



FIG. 87.—The Tutwiler burette for hydrogen sulfide determination in gas.

titration. The iodine solution made up so that 1 cc. contains 0.0017076 gram iodine, which is equivalent to 100 grains of H_2S per cubic foot of gas, is placed in the upper graduated cylinder. The starch solution is made by rubbing 2 grams of wheat starch in a little water and then pouring the mixture into 500 cc. of boiling water. It is contained in the leveling bulb.

The manipulation of the apparatus consists in drawing exactly 100 cc. of gas into the lower burette by means of the leveling bulb. After adjusting the level at atmospheric pressure, the upper stopcock is closed and the solution is lowered to the 110-cc. mark to give a negative pressure. The lower stopcock is now closed. The standard iodine solution is admitted slowly into the middle burette, with shaking between each addition. When the starch solution assumes a faint but permanent blue color, the end point has been reached. A blank should be run on the starch, using 10 cc. of the solution in the same manner as in the regular procedure. The reading for the blank is subtracted from the reading for the determination. From the net volume of iodine solution required, the concentration of H_2S is calculated in grains per 100 cu. ft.

The *total sulfur* in gas is determined either by the Referee's apparatus or by the Drehschmidt method. The former is described in the U. S. Bureau of Standards, *Circular* 48, and is probably more frequently employed in gas-works' practice. The two methods are similar, differing chiefly in the mechanism employed.

The Drehschmidt method is made use of in the author's laboratory and consists of three wash bottles connected to the vacuum system or a water-jet pump. The gas is burned under a trumpet tube which is connected to the washing train for delivering the products of combustion to the alkaline wash bottles which have a 5 per cent solution of Na_2CO_3 with a few drops of bromine water or a small amount of Na_2O_2 added to each bottle. The burning of $2\frac{1}{2}$ cu. ft. of gas is sufficient for a test and the burner should consume about 1 cu. ft. per hour. The meter, barometer and thermometer readings are taken at the beginning and ending of a test. The solutions are transferred to a beaker, made slightly acid with HCl and reduced in bulk by evaporation if necessary. Add about 1 cc. excess of normal

acid and determine the sulfur by means of the turbidimeter, or gravimetrically, in the usual manner.

Heat Values by Calculation.—It will be seen from the foregoing that with an apparatus which compares favorably with a calorimeter in the matter of facility and speed of operation, the method of obtaining heat values for combustible gases by analysis and calculation is given a very much more favorable status. This development will appeal especially to those interested in gas-engine work where exact determinations for the low or net heat values are desired and which require for their satisfactory derivation an analysis of the gas.

The gross and net heat values in B.t.u. for a number of different gases are given in Table XXXIII, and since the values for all

TABLE XXXIII.—HEAT OF COMBUSTION FOR THE MORE COMMON GASES

Gas	Formula	Gross values ¹ calories per gram molecule	Gross values B.t.u. per cubic foot at 60°, 30 in. mercury	Net values ² B.t.u. per cubic foot	Gross values ³ B.t.u. per cubic foot at 60°, 30 in. calculated from net value
Hydrogen.....	H ₂	68,360	326.2	271.8	320.9
Carbon monoxide.....	CO	67,960	323.5	320.9	321.0
Methane.....	CH ₄	211,930	1,009.0	908.5	997.9
Ethane.....	C ₂ H ₆	370,440	1,764.4	1,604.0	1,688.7
Propane.....	C ₃ H ₈	529,210	2,521.0		
Butane.....	C ₄ H ₁₀	687,190	3,274.0		
Ethylene.....	C ₂ H ₄	333,350	1,588.0	1,511.4	1,590.6
Propylene.....	C ₃ H ₆	492,740	2,347.2		
Butylene.....	C ₄ H ₈	650,620	3,099.12		
Acetylene.....	C ₂ H ₂	310,050	1,476.7	1,424.4	1,486.4
Benzene (vapor).....	C ₆ H ₆	799,350	3,807.5	3,571.5	3,634.0

¹ WHITE, A. H., "Technical Gas and Fuel Analysis," p. 301: McGraw-Hill Book Company, Inc., New York, 1920. Temperature of products of combustion reduced to 64.4°F.

² FELBECK, GEORGE T., Thesis: "A Mathematical Determination of the Maximum Pressure and the Extent of Combustion in the Gas Engine:" University of Illinois, 1921.

³ Gross values calculated from Felbeck's net values, using formula as proposed by G. A. Goodenough.

the combustible gases found in the foregoing analysis are included, it is possible to calculate with a good degree of accuracy the heat value of the original gas sample. The heat values given are for standard conditions, 60°F. and 30 in. of mercury, and since the percentages, as determined, hold for the gas under any temperature and pressure condition, all that is necessary in calculating

the total heat value of the sample is to obtain a summation of the percentages of the combustible constituents times their respective heat values. In calculating the heating value of a gas, however, an assumed value for the illuminants must be used, since it is impossible to accurately determine the ratios of unsaturates and benzene vapors in the usual analysis. If the light-oil content of the gas is known, this may be used to give an approximation of the ratio. In general, an assumed gross heating value of 2,000 B.t.u. per cubic foot for the illuminants, with the accepted values for the remaining combustible constituents used, will give the B.t.u. value of the gas with reasonable accuracy.

A coal gas made in a small experimental retort on which analytical and B.t.u. values are available has been taken as an example of calculated heat values. These are shown in Table XXXIV.

TABLE XXXIV.—CALCULATION OF TOTAL HEAT VALUES FROM GAS ANALYSIS

Combustible constituent	Per cent by analysis	Accepted B.t.u.	Resulting heat values
Illuminants.....	5.3	2,000.0	106.0
H ₂	45.3	326.2	147.8
CO.....	8.8	323.5	28.5
CH ₄	31.4	1,009.0	316.8
C ₂ H ₆	1.0	1,764.5	17.6

Total B.t.u. by calculation..... 616.7

Total B.t.u. by Junkers' calorimeter..... 620.0

In case the question is raised as to the presence of higher homologues of the paraffins which might influence the heating value, it is well to note that the value $V(n[757] + 251)$,¹ derived from the heat of combustion of C and H in C_nH_{2n+2}, will give the gross value in B.t.u. for the total paraffins in the sample. In this case $32.4(1.031 [757] + 251) = 334.2$ B.t.u., while the sum of the heat values for methane and ethane as calculated from their percentages is 334.4. This shows the possibility of calculating the gross values for the paraffins without differentiating into

¹ EARNshaw, E. W., *Water gas: Jour. Franklin Inst.*, vol. 146, pp. 161-176, 1898.

the homologues, and in cases where it is impossible to differentiate, as where n is greater than 2, it is still quite possible to obtain the correct heating value of the gas by applying the above formula.

Direct Determination of Heat Values.—Calorimeters for determining the heating value of gases are of the intermittent and of the continuous flow type.

Hempel¹ makes use of an apparatus which burns a volume of gas in an atmosphere of oxygen, the heat being imparted to a known amount of water. By repeating the process using hydrogen under the same conditions as to volume and the amount of water heated, and reducing the temperature readings to the same temperature and pressure, the value of the unknown gas is found by a direct ratio, using an accepted value for hydrogen at standard conditions of temperature and pressure.

Although instruments of the non-continuous type have certain advantages, such as the ability to operate on relatively small samples, they lack the advantage of continuous flow and the opportunity of taking readings at any time. Indeed the trend of development in the matter of determining the heating value of combustible gases must inevitably be toward an instrument which will make a continuous record of the quality of the output.

The first continuous flow instrument was designed in 1893 by Hugo Junkers² and, with minor changes, is the standard instrument of the present time. The general installation is shown in Fig. 88. The cross-section given in Fig. 89 will be of assistance in following the operation of the instrument.

The gas is conducted through a wet meter, then preferably through a pressure equalizer, after which it goes to a Bunsen burner. The products of combustion give up their heat to water under exact control as to temperature and mass. There are specific modifications to be made, including temperature corrections for both the barometer and the meter readings, also for variations in temperature between the inlet water and that of the room, as well as for the humidity of the air. The burner delivers the heat from the gas into the combustion chamber. Since it is essential that all of the heat be extracted from the spent gases, their discharge must be at the bottom of the appa-

¹ HEMPEL, "Gas Analysis," 3d ed., p. 437, 1900.

² JUNKERS, HUGO, *Jour. Gasbeleucht.*, vol. 36, p. 81, 1898.

ratus instead of at the top, the gases in the down-take being heavier than those in the combustion chamber. The principle involved is therefore similar to that of a siphon for liquids. In order to secure an even flow of water through the instrument, a constant head is maintained by means of an overflow cup. On the way down, the water passes the inlet thermometer and is

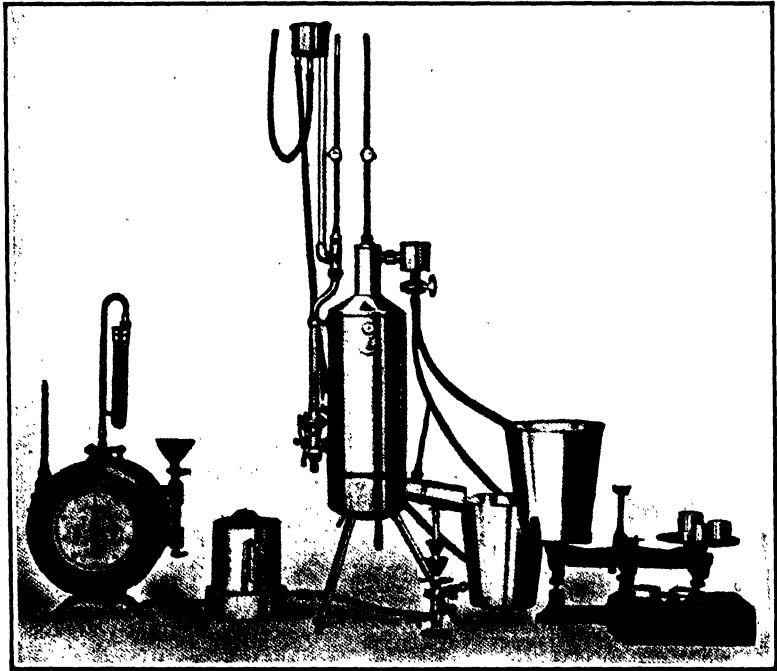

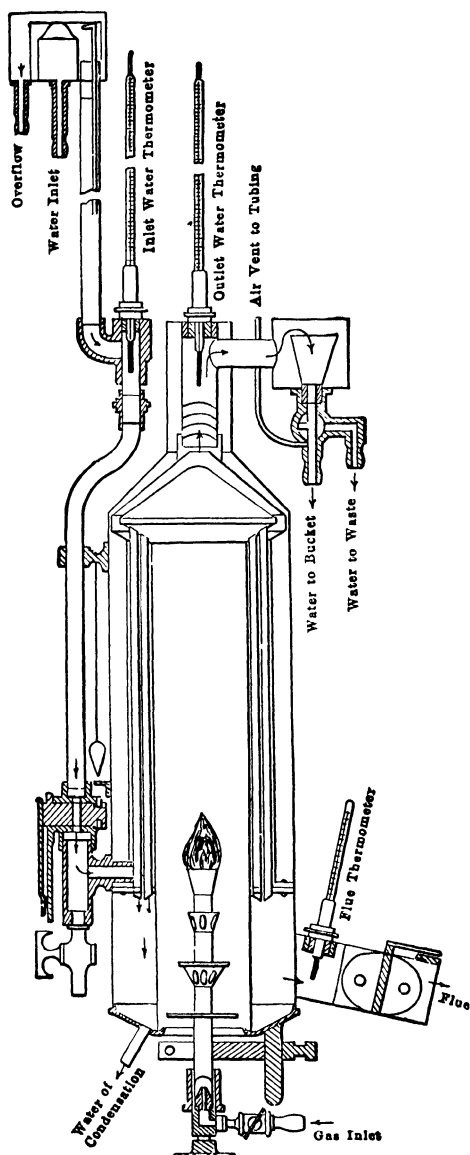

FIG. 89.—Junkers calorimeter showing details of construction.

equivalent volumes at 60°F. and 30 in. of mercury. After applying calibration corrections for inlet and outlet water-temperature readings the true rise in temperature of the water is obtained which, with the reduction of gas volume and weight of the water, gives the essential factors for substituting in the formula:

$$\text{Heat value} = \frac{\text{mass } (t' - t)}{\text{volume in cubic feet}}$$

If the mass is expressed in pounds, t in degrees Fahrenheit, and V in cubic feet, the result will be in gross B.t.u. per cubic foot. The directions for operating the calorimeter as prescribed by the Technical Committee of the American Gas Institute are essentially as follows:

Connect the meter to the governor and the governor to the burner with short pieces of rubber tubing, or with flexible metal tubing having coupled ends.

The calorimeter should be set up in a quiet, light and well-ventilated room or cabinet, which is free from draughts and in which the temperature can be maintained constantly at not less than 60°F. The room should be provided with a sink and large, shallow, overhead covered tank from which the water supply can be taken. Should the tank capacity be small and not hold enough water for a prolonged series of readings, a small gas water heater may be employed to bring the water to approximately the room temperature. It is desirable to use water that is clear and free from suspended matter in the calorimeter; therefore, a filter should be installed in the water supply line before it enters the overhead tank.

If only a single test is desired, gas may be taken from the house piping, but if an average value is required, a small gas holder, or averaging tank, should be used, and the gas flowing into the holder adjusted to a rate of flow to just fill it in the time during which the sample is to be taken. Care should be taken to have a short service to this holder in order that an average sample of gas may be obtained, and if the sample be taken from a line on which there is no considerable consumption, see that this line is thoroughly purged before sampling. It is recommended that the gas be metered at a pressure not to exceed 2 in.

of water; if this is not obtainable, it is advisable to insert a holder or diaphragm governor in the supply line, to reduce the pressure to within this limit.

Make water connections with rubber tubing, being careful not to cramp the tubing. To avoid air currents caused by the movement of the observer's body, set up the calorimeter so that the water supply and waste may be easily adjusted and that all temperatures may be readily observed. Lead the outlet water to a waste funnel supported a little above the top of the copper or glass container used in collecting the water, so that the water can be shifted from the funnel to the container and back without spilling.

Set up the gas meter facing the observer and level it carefully. Then adjust the water level of the meter, both inlet and outlet being open to the air. If the meter has been filled with fresh water, the gas must be allowed to burn at least 2 hr. before making a test. When the water in the meter is saturated with gas, 20 min. should be sufficient.

Fill pressure regulator with water, about three-fourths full, then connect it to the calorimeter burner. Metallic tubing is preferable but, when rubber tubing is used to connect meter, pressure regulator and burner, connections should be as short as possible, and should be saturated with the gas.

Turn on the gas and allow it to burn for 5 to 10 min. with the burner on the table. Shut off the gas at burner and watch the hand on the meter for leakage. Be sure that all leaks are stopped before attempting to make a test. Start water running through the calorimeter at a rate of about 3 lb. per minute. Then regulate the gas to flow at the rate of 4 to 7 ft. an hour, as may be found by experiment to give the highest result with the gas to be tested, admitting enough air through the burner so that the flame shows a faint luminous tip; then insert the burner as far up into the combustion chamber as the bracket permits, and observe again the condition of the flame to see that it is all right, using a mirror.

The excess of air passing through the calorimeter is controlled somewhat by the position of the damper. Some experimentation may be necessary. Operate the calorimeter until a thermal balance is established on the inlet and outlet water thermometers.

Start with the damper closed, then open slightly, observing carefully the outlet thermometer. When this thermometer reads at a maximum—or in other words, when the greatest rise in temperature is given to the water—which is presumably passing through the calorimeter uniformly—the damper is in approximately the correct position for the amount of gas being burned, and the excess air necessary for perfect combustion is at a minimum.

Water should be regulated so that there is a difference between the inlet and the outlet temperatures of about 15°F. The temperature of the inlet water should vary but little when an overhead tank is used and the water maintained at room temperature. Be sure that both overflows are running.

Before making the test, the barometer, the temperature of the gas at the meter, temperature of room and temperature of exhaust products should be recorded. It is desirable to have the temperature of the inlet water and temperature of exhaust products as nearly as possible at room temperature in order to establish more nearly a thermal balance. The differences in these temperatures should never exceed 5°.

Next allow the gas to burn in the calorimeter until a thermal balance is established, or until there is the least change in the inlet and outlet waters. The condensed water should also commence to drip showing an equilibrium status within the calorimeter.

The test may now be started by shifting the outlet water from the funnel to the container, just as the large hand on the meter passes the zero point. Readings are then made of the inlet and outlet thermometers, making the readings as rapidly as the observer is able to record them during the consumption, preferably of $\frac{2}{10}$ cu. ft. of gas. At least 10 readings should be made of both inlet and outlet water temperatures. Water is again shifted from the container to the waste funnel as the hand passes the zero point the second time. Water is then weighed or measured. The uncorrected gross heating value per cubic foot is obtained by multiplying the average difference between the inlet and outlet temperatures by the number of pounds of water and dividing by the volume of gas burned. This quantity is divided by the correction factor for barometer and temperature, obtainable from the tables in the Appendix, to give the heating

value at 30 in. pressure and 60°F. The weight or contents of the container should be obtained while the inside is wet. This may be done by filling it with water, emptying and shaking for about 5 sec. in an inverted position. This will do away with any correction where several consecutive tests are required with the same container.

A second and, perhaps, a third test is advisable, and these should be made without disturbing the existing conditions, provided all readings are within the above prescribed limits. In practice, the operator should get consecutive results on the same holder of gas within 10 B.t.u. Under such conditions an average of the results may safely be taken. The water of condensation should be caught in a 50-cc. graduate so that calculation can be made for the net heating value if desired. It is better to collect the condensate from a total of 1 cu. ft. for making the estimate. The latent heat of vaporization for water at the initial temperature of the gas and air is taken as 0.600 cal., hence the number of cubic centimeters of condensed water from 1 cu. ft. of gas multiplied by 0.600×3.968 will equal the B.t.u. to be subtracted from the total observed values as given by the calorimeter for the net B.t.u.

Gross and Net Heating Values.—Gross heating values are those in which the products of combustion are reduced to standard conditions, *i.e.*, 60°F., 30 in. of mercury, and are saturated with water vapor to the same degree as were the gas and air supporting the combustion. This is the maximum heat which may be obtained by burning a gas and is the amount which is approached in the determination of the heating value with the calorimeter. In the usual combustion of gas in commercial appliances the products are not cooled below the dewpoint and thus the latent heat of condensation, as well as a small amount of sensible heat of the products, is not made available. Net heating values are calculated from the gross values by measuring the amount of condensed water and correcting for its heat of condensation at the final temperature of the products. This more nearly approaches the amount of heat that becomes available from commercial burners, although, owing to the losses that occur in the sensible heat of the waste gases, even this net heating value is not realized commercially.

Specific Gravity of Gas.—The specific gravity of gas is important in combustion practice, as slight changes will affect burner operation. Therefore, where mixed gases are used, it is not only necessary that the blend remain constant in heating value but also that the specific gravity is carefully controlled.

The density of a gas from which the specific gravity may be calculated may be determined easily by carefully weighing a known volume in a suitable container under known conditions of temperature and pressure.

A more simple method is by effusion of a volume of gas through a small orifice under conditions which can be repeated, using air instead of gas. By accurately measuring the effusion time for both, the specific gravity for the gas as compared to air is determined:

$$\text{Specific gravity gas} = \frac{(\text{effusion time gas})^2}{(\text{effusion time air})^2} \text{ or } \frac{t_g^2}{t_a^2}$$

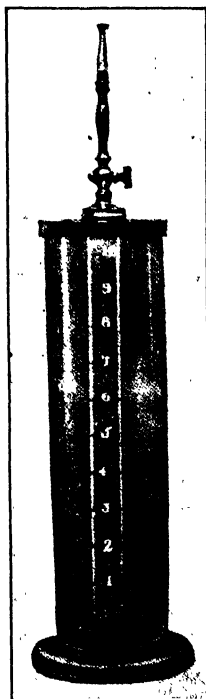

FIG. 90.—Schilling specific gravity apparatus for gas.

The apparatus (Fig. 90) is known as the Schilling, or Bunsen specific gravity apparatus. It consists of a vertical tube suspended in a cylinder of water. The tube is open at the lower end and has a two-way stopcock attached to the upper end. This stopcock allows the tube to be connected either to the gas supply or to a small, fixed orifice. There are two fixed marks on the tube near the top and bottom, both of them under the surface of the water in the cylinder. In determining the specific gravity of a gas, the tube is allowed to fill with the gas. Then it is connected to the orifice, and water from the cylinder allowed to displace the gas. The time required for the meniscus in the tube to pass the two marks is accurately taken. This is then repeated, using air instead of gas, and the specific gravity is available from the two determinations by applying the formula.

CHAPTER XXX

THE ANALYSIS OF FLUE GASES

Sampling and Analysis.—According to Professor White¹ “the problem of obtaining a representative sample of a gas for analysis presents in many cases more difficulties than the analysis itself.” These difficulties relate chiefly to leakage in the boiler setting, irregularity of flow in the cross-section of the chimney or gas conduit, chemical reaction with the tube used for sampling, faulty or leaky connections, solubility of the sample in water, etc. The avoidance or minimizing of these difficulties is a problem for each plant. In general the leakage in the boiler setting should be remedied or minimized by a liberal use of some sort of luting material on all cracks or openings not intentionally provided for draft purposes. The point for taking the sample should also be as near the combustion zone as possible. In cases where it is desired to take samples within the zone of combustion, a special collecting device with a water-cooled conduit to avoid chemical change in the sample is necessary.²

The difficulty of variations in the flow across the area of the conduit is best met by use of a multiple collecting device made by assembling a bundle of varying lengths of heavy pyrex glass or refractory tubing in a convenient holder, and held in place by portland or, still better, “hytempite” cement. Rubber tubing should be confined to short connections only and use made of glass or metal tubing. None of the water used in aspirating or by gravity displacement in collecting the sample should remain in the holder in which the gas is collected for transmission to the laboratory. The analysis of the gas is not essentially different from that already discussed under fuel gases, except that a smaller number of processes are employed. The determi-

¹ WHITE, A. H., “Technical Gas and Fuel Analysis,” pp. 1-13: McGraw-Hill Book Company, Inc., New York, 1920.

² SHERMAN, R. A., A study of refractory service conditions in boiler furnaces: U. S. Bur. Mines, *Bull.* 334, p. 30, 1931.

nations ordinarily required in a flue-gas analysis are for CO_2 , O_2 , CO and N_2 by difference. The instrument most conveniently arranged for this work is the Orsat apparatus. It should be assembled in the simplest form and rugged in construction to meet the conditions of portability. The prescriptions for use have already been given in connection with the larger instrument, page 277. Indeed that apparatus is simply an enlarged or extended Orsat. It is adapted to all the uses intended for the

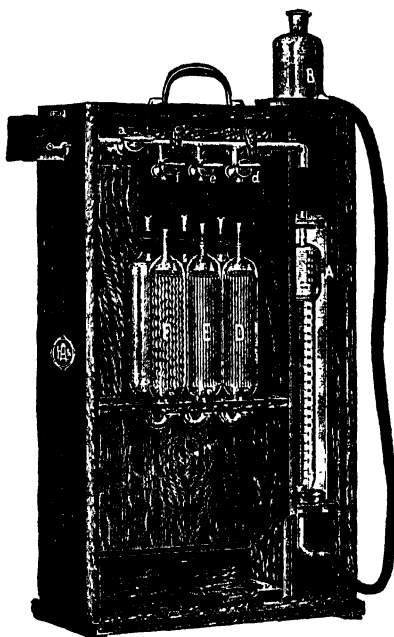

FIG. 91.—Orsat apparatus.

smaller or Orsat apparatus proper, except ready transportation. In the regular or small Orsat, carbon monoxide is determined by solubility in ammoniacal cuprous chloride instead of by fractional combustion. The large apparatus is therefore better adapted for work with fuel gases, having a high content of CO , while the absorption method as employed in the small Orsat is well adapted for work with flue gases.

Orsat Reagents.—The Orsat apparatus (Fig. 91) is made of a jacketed gas burette and leveling bottle permanently connected

by a capillary tube having four side arms to three pipettes and to the open air. The end of the capillary tube extends outside the case for convenience in taking a sample of gas. The pipettes are provided with reagents as follows:

1. Potassium hydroxide, for absorption of carbon dioxide, CO_2 . Strength of solution 40 per cent. One cubic centimeter absorbs 40 cc. of carbon dioxide.

2. Potassium pyrogallate for absorption of oxygen, O_2 . Equal volumes of 33 per cent KOH and 25 per cent pyrogallic acid solutions are mixed together. One cubic centimeter will absorb 8 cc. of oxygen.

3. Cuprous chloride for the absorption of carbon monoxide, CO . A solution of cuprous chloride is prepared by dissolving Cu_2Cl_2 in hydrochloric acid (sp. gr. 1.12) in the ratio of 15 grams of the salt to 100 cc. of acid. The activity of the solution depends on the presence of copper in the cuprous form. If pure, the solution would be colorless. It turns green upon oxidation. It should be kept from the light and occasional additions of copper wire or turnings made to the accessory pipette or the stock bottle.

Procedure.—Adjust the reagent in each pipette by drawing the solution up into the capillary tube to the mark just below the rubber connection. Fill the jacketed measuring burette with water out to the end of the capillary tube by raising the leveling bottle. Now, after thoroughly washing out the lines connecting the Orsat to the sampling device, fill the burette with gas to a point just below the zero mark. This can be accomplished either by lowering the leveling bottle or by the use of a small rubber aspirator bulb. Next, adjust the level of the water to the zero mark at atmospheric pressure by pinching the rubber tube to the leveling bottle, opening the three-way stopcock to the atmosphere, and slowly allowing the water to enter the burette from the bottle.

A precaution should be taken to see that the water in the burette and bottle is saturated with the gases to be analyzed, else some absorption will take place and low results will be obtained. For this reason it is usually advisable to aspirate the gas through the burette and leveling bottle before collecting a sample. Slightly acidulated water should be used. The presence of a few drops of methyl orange can be used to detect any contamination resulting from accidentally drawing alkaline liquid from the pipettes into the burette, and also to make the meniscus clearly visible.

a. Carbon Dioxide.—Close the three-way stopcock to the burette and open the cock on the first pipette which contains the potassium hydroxide; now raise the leveling bottle slowly, thus forcing the gas into the pipette. Draw the gas back into the burette, and repeat the absorption twice. Finally adjust the level of the liquid in the pipette again to the zero mark. The caustic solution should not be allowed to enter the stopcock or capillary manifold as it interferes with later determinations. Adjust the meniscus in the burette to atmospheric pressure by leveling with that in the leveling bottle. Read the decrease in volume as per cent CO_2 .

b. Oxygen.—In a similar way absorb the oxygen in the pyrogallate solution. Note that the reading on the burette is the sum of $\text{O}_2 + \text{CO}_2$.

c. Carbon monoxide is determined after oxygen, by means of the third pipette. On account of the vapor pressure of hydrogen chloride over the solution used for absorption, it is necessary to wash the gas in the caustic pipette after the carbon monoxide is removed and before the reading is taken.

d. Nitrogen is determined by the difference:

$$100 - (\text{CO}_2 + \text{O}_2 + \text{CO}) = \text{N}_2$$

Calculation of Efficiencies and Heat Losses.—The flue-gas constituents and temperatures afford a basis for calculating efficiencies and heat losses. Three general features are usually included as follows:

- a.* The number of pounds of air entering per pound of fuel.
- b.* The ratio of air entering the grate to the air used.
- c.* The loss of heat passing up the chimney.

a. Pounds of Air Entering per Pound of Coal.—The gram-molecule of any gas, that is, the molecular weight of the gas in grams, has a definite volume and is the same for all gases, namely, 22.4 liters at standard temperature and pressure. For example 44 grams of CO_2 has a volume of 22.4 liters; 32 grams of O_2 has a volume of 22.4 liters, etc. In a mixture of gases, therefore, the weight of each constituent, W , in 22.4 liters equals the molecular weight times the percentage present, thus:

$$W = \text{molecular weight of component} \times \text{per cent} \quad (1)$$

In arriving at the weight of air entering the grate, the weight of the total nitrogen will give the most direct factor for calculating the air. For example, making use of Eq. (1) the weight of nitrogen, W^1 , in a gram-molecular-volume would be:

$$W^1 = 28 \times \text{per cent } N_2$$

In order to refer the weight of nitrogen present to a unit quantity of fuel we shall need to determine, first, the amount of pure carbon involved in the production of the unit volume of flue gas. This can be readily accomplished by deriving the weight of carbon in the gas and making 1 gram of carbon the unit of reference. For example, $1\frac{1}{4}$ of the CO_2 and $1\frac{1}{2}$ of the CO present is carbon.

If we let C represent the weight of carbon in the unit volume, then

$$C = 1\frac{1}{4} \times 44CO_2 + 1\frac{1}{2} \times 28CO$$

hence

$$C = 12(CO_2 + CO)$$

If, therefore, C represents the number of grams of carbon which deliver a flue gas with W^1 grams of nitrogen, then the weight of nitrogen per gram of carbon burned is W^1/C or in terms of the assigned values,

$$W^1 = \frac{28N_2}{12(CO_2 + CO)} \text{ or } \frac{7N_2}{3(CO_2 + CO)} \quad (2)$$

Assuming for illustration a chimney gas of the following composition:

	Per Cent
CO_2	10 0
O_2	8 0
CO	0 5
N_2	81 5

resulting from the combustion of a coal having 70 per cent of carbon exclusive of the carbon lost in the ash. Then, by substituting these values in Eq. (2), we have:

$$W^1 = \frac{7 \times 81.5}{3(10 + 0.5)} = 18.11 \text{ grams } N_2$$

That is, 18.11 grams nitrogen in the flue gases accompany the combustion of 1 gram of carbon. Similarly, there would be 18.11 lb. of nitrogen in the flue gases from 1 lb. of carbon, and for a coal of 70 per cent carbon the weight would be $0.70 \times 18.11 = 12.68$ lb. N_2 . Since nitrogen passes through the furnace unchanged, the calculation to the equivalent weight of air entering is:

$$77:100::12.68:x$$

$$x = 16.47$$

Hence the weight of air entering per pound of coal is 16.47 lb.

b. Ratio of Air Entering to Air Used.—From the discussion under (a) the weight of oxygen per pound of carbon would be represented by the expression,

$$W^1 = \frac{32O_2}{12(CO_2 + CO)} \text{ or } \frac{8O_2}{3(CO_2 + CO)} \quad (3)$$

Substituting the values indicated under (a) we have

$$W^1 = \frac{8 \times 8}{3(10 + 0.5)} = 2.03$$

and for a coal having 70 per cent of carbon the weight would be 1.42 lb. per pound of coal. Calculating the oxygen to the equivalent of air,

$$23:100::1.42:x$$

$$x = 6.17$$

Hence, the weight of air passing through unused is 6.17 lb. per pound of coal.

From (a) and (b), therefore,

	Pounds
Total air entering.....	16.47
Air unused.....	6.17
Air used.....	10.30

$$\frac{16.47}{10.30} = 1.60, \text{ ratio of air entering to air used.}$$

c. The Loss of Heat Passing up the Chimney.—The factors which enter into the calculation of heat losses in chimney gases are (1) the weight of the flue gas per pound of fuel, (2) the specific

heat in B.t.u. per pound, and (3) the rise in temperature or difference in temperatures ($t - t^1$) between the entering air and the gases as they leave the furnace.

1. The weight of the gas per pound of fuel may be readily derived from the formula for W as developed under (a) and (b) above. Letting W_v represent the weight of the mixed gases per pound of pure carbon, then, by a similar procedure to that shown in Eq. (2) under (a) and Eq. (3) under (b), we would have for the total weight of all of the components per pound of carbon:

$$W_v = \frac{11\text{CO}_2 + 8\text{O}_2 + 7\text{CO} + 7\text{N}_2}{3(\text{CO}_2 + \text{CO})} \quad (4)$$

Or, since $\text{CO} + \text{N}_2 = 100 - \text{CO}_2 - \text{O}_2$, this expression may be still further simplified to read:

$$W_v = \frac{4\text{CO}_2 + \text{O}_2 + 700}{3(\text{CO}_2 + \text{CO})} \quad (5)$$

Assuming the coal used as in (a) and (b) to have 70 per cent of carbon (the carbon of the ash having been subtracted), then by substituting the percentage values for the chimney gas as already indicated and multiplying by 0.70 we would have the weight of gases per pound of fuel:

$$W = \frac{4 \times 10 + 8 + 700}{3(10 + 0.5)} \times 0.70 = 16.62$$

Therefore, for 1,

$$W = 16.62 \text{ lb. dry gases per pound of fuel}$$

2. The specific heats of the various components, at constant pressure in B.t.u. per pound, calculated for the interval, 60°F.-600°F.

$$\begin{aligned} \text{CO}_2 &= 0.222 \\ \text{O}_2 &= 0.217 \\ \text{CO} &= 0.245 \\ \text{N}_2 &= 0.2407 \\ \text{H}_2\text{O} &= 0.4673 \end{aligned}$$

From which it appears that an average specific heat of 0.24 for all the constituents exclusive of water vapor may properly be

applied. Assuming, therefore, the $(t - t')$ values of 60° entering and 600° leaving, we have a total loss L for the dry gases, thus:

$$L = 16.62 \times 0.24 \times 540$$

$$L = 2,154 \text{ B.t.u.}$$

Assuming a heat value of 12,000 B.t.u. for the coal per pound as fired, then the percentage loss L' would be,

$$L' = \frac{2,154}{12,000} \times 100$$

$$L' = 17.95 \text{ per cent}$$

Other Losses.—In obtaining a heat balance as in boiler tests, other heat losses are taken account of. They include:

- A. The latent heat of vaporization of moisture.
- B. The heat of the water vapor passing off at the temperature of the chimney.
- C. The heat due to combustion of carbon to CO, instead of to CO₂.
- D. The unburned carbon in the ash.

A. The water from which the loss of heat is calculated is made up of:

- a. The total hydrogen of the coal burning to H₂O, that is $H \times 9$.
- b. The free moisture of the coal.
- c. The moisture of the air as indicated by the relative humidity.

The sum of the three amounts of water referred to the unit of 1 lb. of coal multiplied by the factor for the latent heat of vaporization represents the heat loss in B.t.u. per pound of coal thus;

$$\text{B.t.u. loss per pound of coal} = \text{weight of H}_2\text{O} \times 966$$

B. Having found the weight of water as under (A) the heat loss due to rise in temperature from room temperature, t , to 212° , and from 212° to temperature of flue gases, T , is found, using the specific-heat factor for the water vapor, of 0.467, thus:

$$\text{B.t.u. loss per pound of coal} = \text{H}_2\text{O} \times (212 - t) + \text{H}_2\text{O} \times 0.467 \times (T - 212)$$

C. The heat loss due to the burning of carbon to CO instead of CO₂ is found by multiplying the weight of carbon thus entering

into the reaction per pound of coal, by the difference between the calorific value of carbon burned to CO_2 and carbon burned to CO , thus:

B.t.u. loss from CO per pound of coal = weight C in $\text{CO} \times 10,150$

D. The loss of heat due to combustible matter passing through with the ash unburned is found by determining the combustible in the ash as carbon c , and referring it to the total refuse r in its proper proportion x to the ash a of the original fuel, thus:

$$c:r::x:a$$

Having the value x in percentage of the original coal as fired, then:

Heat loss per pound of coal from unburned carbon = $x \times 14,550$

In the use of the factor 14,550, it is assumed that the residual combustible in the ash is carbon only, with a heat value as indicated.

CHAPTER XXXI

ANALYSIS OF BOILER WATERS

Normal Solutions.—If the reaction between one solution and another can be gaged exactly as to the “end point,” that is, if that point can be noted where an exact balance exists between the two reacting substances, we may make use of these solutions as media for making chemical measurements, just as a mechanic uses a foot rule for measuring lengths. Given, therefore, a solution of known value, that is, a standard solution, and a reaction where the end point or chemical equilibrium can be made visible to the eye by any means, we have a method which can be used to measure other solutions of unknown value. When a standard solution has its chemical value made up in terms of the molecular weight of the substance in grams per liter, it is called a molar solution. It is more convenient, however, to make up such solutions on the basis of the hydrogen equivalent of the part of the molecule concerned, in order to avoid the necessity of multiplying or dividing by 2 where ions of different valencies interact.

Thus, $2\text{HCl} + \text{Na}_2\text{CO}_3 = 2\text{NaCl} + \text{H}_2\text{CO}_3$ would call for two molecular quantities of HCl and one of Na_2CO_3 , or one of HCl and $\frac{1}{2}$ of Na_2CO_3 .

Again, $\text{HCl} + \text{Na}_2\text{CO}_3 = \text{NaCl} + \text{NaHCO}_3$ would call for one full molecular quantity of HCl and one molecular value for the Na_2CO_3 . By common agreement the single hydrogen equivalent has been adopted as the basis and solutions of this kind are called normal solutions. Hence a normal solution of the first substance, HCl, has exactly 36.46 grams per liter. A normal solution of the second has exactly 53.00 grams or one-half of the molecular weight, 106.0, of sodium carbonate per liter. Where solutions of less strength are needed, tenth or hundredth normal solutions are used, expressed thus: $N/10$ or $N/100$. Thus, $N/10$ sodium carbonate has 5.300 grams of the pure

substance per liter, and each cubic centimeter contains 0.0053 gram of the alkali.

It is important that the full significance and value of the process involving normal solutions be well understood at the outset of the work. The preliminary experiments following will help to this end.

EXERCISE I

Standard Sodium Carbonate.—The preparation of $N/10$ sodium carbonate solution is carried out as follows:

Clean and dry a porcelain crucible or small porcelain dish, then ignite it lightly and cool down to room temperature, putting into the desiccator at about 150° . Weigh accurately and add about 6 grams, more or less, of pure, dry sodium carbonate. Raise to a red heat, short of melting, and cool in a desiccator. Counterpoise upon the balance in such a manner that by removing with a clean knife blade or spatula the excess of material, there shall remain in the crucible exactly 5.300 grams of the carbonate. Empty the carbonate into a No. 3 beaker and add 50 or 100 cc. of distilled water. Rinse out the crucible also, a number of times, adding the washings to the beaker. After solution of the carbonate is complete, pour the contents of the beaker into a liter measuring flask. Rinse out the beaker thoroughly, transferring the washings to the flask and make up finally to the mark. The temperature of the water employed for making up to volume should not exceed 20°C . Stopper and mix by shaking until an absolute certainty of uniform distribution of the solution is attained. If the sodium carbonate is pure and the proper care, in regard to transferring, mixing temperature, etc., has been observed, we should now have a strictly $N/10$ solution. To test its accuracy, obtain from the instructor some of the ready prepared $N/10$ hydrochloric acid solution and proceed as follows:

Measure about 20 cc. of the sodium carbonate from a burette into a clean beaker. Add about 20 cc. of water and 2 drops of methyl orange solution. Titrate very slowly with $N/10$ hydrochloric acid from a burette. Add acid, drop by drop, until the yellow turns to an orange color. More acid will make the solution pink, but this is too far—the intermediate orange tint

denoting neutrality. More accurate results will be obtained if the solutions are titrated back and forth until 1 drop of either solution will change the color of the indicator. Repeat this titration three times and average the results. The quantity of acid required should not vary from the solution taken by more than 0.1 cc. If there is a greater difference than this, the strength of the sodium carbonate solution may be calculated from the known hydrochloric acid solution. This correction is known as the $N/10$ factor. The factor must be taken into consideration whenever the sodium carbonate solution is used. The exactly $N/10$ solutions are much to be preferred where a large number of determinations are being made. What applies to the sodium carbonate solution is equally true with all standard solutions that are used. From the $N/10$ sodium carbonate solution make a $N/50$ sodium carbonate solution.

EXERCISE II

Standard Sulfuric Acid.—Prepare a $N/10$ solution of sulfuric acid by means of the $N/10$ Na_2CO_3 solution as follows:

Measure about $3\frac{1}{2}$ cc. of pure concentrated sulfuric acid into a flask containing 1,050 cc. of distilled water. Mix thoroughly and fill a 50-cc. burette with the solution. Measure 20 cc. from the burette into a clean beaker, add about 20 cc. of water and 2 drops of methyl orange. Titrate slowly with $N/10$ sodium carbonate solution from a burette until the end reaction is shown by the first change of color from pink to orange. Repeat the titration as before, being careful to note the correct color for the end point. The acid solution is probably too strong. If the titration with $N/10$ sodium carbonate requires, say, 21 cc. instead of 20 cc., then, in such case, 20 cc. of acid would need to be diluted to 21 cc. to make an exact balance to the alkali solution. Similarly 200 cc. would need to be diluted to 210 cc. and the dilution for any amount would be indicated by the proportion

$$20:21::1,000:x$$

Hence, in the above example, measure an exact 1,000 cc. of the trial acid and add 50 cc. of pure water to it. Test the

accuracy of the resulting solution with *N/10* sodium carbonate as before.

EXERCISE III

Determination of Sulfur.—(Consult also the description for the determination of sulfur under Sulfur Determinations, page 260.)

Measure out 10 cc. of the *N/10* sulfuric acid solution and make up to 100 cc. Measure carefully 50 cc. of this solution into a 200 cc.-cylinder. Add 25 cc. of the NaCl-HCl solution described on page 263, and make up to the 200-cc. mark, pour into an Erlenmeyer flask and add one measure of barium chloride crystals and shake vigorously for about 1 min. Now place the entire 200 cc. in the turbidimeter and take readings in the same manner as explained for sulfur in coal.

From the curve on page 262, estimate the number of milligrams of sulfur in the sample taken. Calculate the weight of sulfur indicated to sulfuric acid. Note that the actual amount of the *N/10* solution taken for the test is 5 cc.

One cubic centimeter of *N/10* sulfuric acid has what weight of acid present? How much sulfate? What would be the equivalent amount of hydrochloric acid? sodium carbonate? calcium carbonate?

EXERCISE IV

Standard Calcium Chloride and Soap Solutions.—Measure from a burette into a clean No. 2 beaker 40 cc. of *N/10* hydrochloric acid. What equivalent does it contain in terms of sodium carbonate? What equivalent in terms of calcium carbonate? Weigh carefully approximately 0.250 gram of pure calcium carbonate powder and add it to the 40 cc. of *N/10* hydrochloric acid. Cover with a watch glass and heat for a few minutes till all action has ceased. Transfer to a liter flask. Wash out the beaker thoroughly with distilled water, transferring the washings to the flask. Make up to the mark and mix thoroughly by shaking. Allow the contents to stand quietly until all undissolved material has settled to the bottom. Siphon off half or more of the clear solution into a suitable flask and label "Standard Calcium Chloride Solution." Since 1 cc. of a *N/10*

solution is equivalent to 1 cc. of any other *N*/10 solution, we have in the above solution 40 cc. of a *N*/10 CaCl_2 solution. Although calcium carbonate is not soluble in water, the 40 cc. of *N*/10 calcium chloride is equivalent to the amount of calcium carbonate in 40 cc. of a theoretical *N*/10 solution of calcium carbonate. Since in 1 cc. of a *N*/10 solution of calcium carbonate there are 0.005 gram of calcium carbonate, in the 40 cc. of hydrochloric acid solution or the liter of solution there are 0.2 gram of calcium carbonate. The standard calcium chloride solution, therefore, has a value of 200 p.p.m. in terms of calcium carbonate.

The standard soap solution is prepared by dissolving 10 grams of castile soap in 100 cc. of 80 per cent alcohol. After standing for several days it is further diluted with 70 per cent alcohol to a point where 5 or 6 cc. of it, as measured from a burette, will produce a permanent lather when added, as directed below, to 20 cc. of the standard calcium chloride solution. This will require usually a dilution up to 900 or 1,000 cc.

Standardization of the Soap Solution.—Measure 20 cc. of the standard calcium chloride solution into a 250-cc. glass-stoppered bottle and add 30 cc. of distilled water. Run in from a burette the standard soap solution, 0.4 or 0.5 cc. at a time, shaking the bottle vigorously after each addition. Lay the bottle on its side after each shaking and note if the lather remains. The end point is taken where the lather remains over the entire surface of the water for 5 min. after shaking. Make three tests of the standard calcium chloride solution as above prepared. Repeat the process, using 10 cc. of the calcium chloride solution and making up to the same volume (addition of 40 cc. of water) as before. By thus establishing a number of points as for 10, 15, 20 and 25 cc., in which the required soap solution has been determined, a curve for the strength of the soap solution is developed as illustrated in the chart, Fig. 92.

The hardness of a water is due to any mineral constituents in solution other than compounds of sodium, potassium, ammonium, etc., members of the first or soluble group. Upon the addition of soap to a hard water there are formed insoluble soaps of calcium, magnesium and iron, which are precipitated in curdy granules. When all of these constituents are precipitated the

water is soft. It is this action of soap which permits of its use in a standard solution for measuring the total hardness.

EXERCISE V

Determination of Calcium Sulfate in Water.—Get a bottle of unknown *A* for analysis. Add 25 cc. to a clean beaker with a

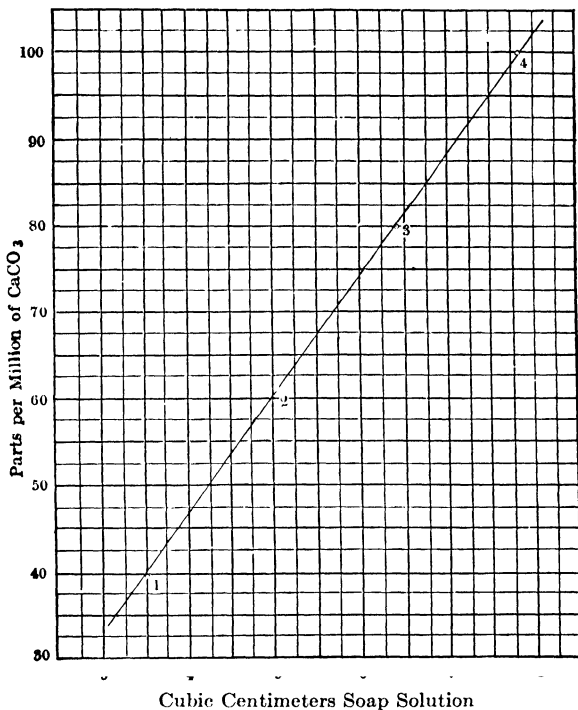
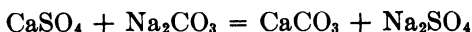

FIG. 92.—Development of the curve for a standard soap solution with the points located as follows: Point 1, using 10 cc. CaCl_2 solution. Point 2, using 15 cc. CaCl_2 solution. Point 3, using 20 cc. CaCl_2 solution. Point 4, using 25 cc. CaCl_2 solution.

pipette, then run in 10 cc. of $N/10$ sodium carbonate solution. Boil for 5 min. on a sand bath, then filter into a clean beaker. Wash well with hot water, saving all the washings until the liquid leaving the funnel is neutral to litmus paper. Now add 2 drops of methyl orange to the filtrate and washings, and titrate with $N/10$ hydrochloric acid.

The equation representing the reaction between sodium carbonate and calcium sulfate is



Since the titrated sodium carbonate is the balance of the 10 cc. remaining unchanged after the reaction has taken place, the difference between this amount and the 10 cc. originally added represents the amount of sodium carbonate taking part in the reaction, and from this, remembering always the equivalent of normal solutions, compute the weight of calcium sulfate present. Since a 25-cc. sample was taken, how many *grams per liter* did the solution contain? How many parts per million? How many grains per U. S. gallon?¹

Calculate the lime, in grains per gallon, equivalent to the calcium sulfate present. Calculate also the equivalent of calcium carbonate in grains per gallon corresponding to the sulfate ion present. From the amount of hydrochloric acid used, calculate the sodium chloride (NaCl) formed.

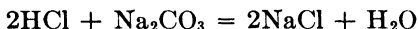

Perform all these calculations in the notebook for inspection and reference.

EXERCISE VI

Excess or Free Carbon Dioxide.—By this is meant the carbon dioxide held in solution by the water. It is not scale-forming material, but in water treatment it behaves as so much temporary hardness, and the amount present must be determined in order to gage correctly the quantity of reagent required in the treatment. The excess carbon dioxide is readily taken up by calcium hydroxide ($\text{Ca}[\text{OH}]_2$), forming calcium carbonate; or by sodium carbonate, forming sodium bicarbonate. So long as there is present free carbon dioxide, it acts toward phenolphthalein as acid, decolorizing the same. The first excess of Na_2CO_3 beyond the point of absorption of the CO_2 is denoted by a pink coloration of the indicator.

¹ Milligrams per liter or part per million $\times 0.0583 =$ grains per U. S. gallon.

Procedure.—With the graduated cylinder measure 200 cc. of the water into a No. 3 (350-cc.) beaker. Add a few drops of phenolphthalein as an indicator and titrate to the end point with $N/50$ sodium carbonate free from bicarbonate. The number of cubic centimeters used, times 5, represents the equivalent or excess of CO_2 in parts per million, but measured in terms of calcium carbonate.

EXERCISE VII

Total Alkalinity and Temporary Hardness.—Temporary hardness is due to the calcium, magnesium and iron held in solution in the form of bicarbonates. They are readily broken down by dilute acids and, until so destroyed, are alkaline towards methyl orange indicator.

Procedure.—Measure 200 cc. of the water into a No. 3 beaker, add a few drops of methyl orange and titrate with $N/10$ sulfuric acid. From the number of cubic centimeters used can be calculated the equivalent in parts per million of temporary hardness measured in terms of calcium carbonate. Note that to calculate the value in cubic centimeters per liter we would need to multiply the titration by 5. The equivalent value for $N/10$ sulfuric acid in terms of calcium carbonate is 0.005 gram per cubic centimeter of solution. Hence, five times the number of cubic centimeters per liter would represent the calcium carbonate in milligrams per liter. That is, 25 times the titration number represents milligrams per liter or parts per million of calcium carbonate equivalent.

Note.—If under Exercise X, below, sodium carbonate is found to be present as negative hardness, the temporary hardness is equal to the total alkalinity minus the negative hardness. If there is no negative hardness the temporary hardness is equal to the total alkalinity.

EXERCISE VIII

Magnesia.—Use the solution from Exercise VII above. Cover the beaker with a watch glass, boil for 15 min., add 50 cc. of saturated lime water and allow to stand at a temperature near the boiling point for about 15 min. Filter into a 250-cc. flask, wash the precipitate with boiled distilled water, adding the washings to the filtrate. Now add water until the volume at room

temperature is 250 cc. Titrate 100 cc. with $N/10$ sulfuric acid, using the methyl orange indicator. Make at the same time the same determination, using pure distilled water in place of the water analyzed. The difference between the two titrations is the amount of sulfuric acid which would have been neutralized by the calcium hydroxide which has precipitated the magnesium from the water. Since the amount titrated, 100 cc., is equal to two-fifths of the 250 cc., it must also be equal to two-fifths of the original 200 cc. Then the difference between the titrations multiplied by $\frac{5}{2} \times 5 \times 5$ equals the equivalent in parts per million of the magnesia in the water measured in terms of calcium carbonate.

Note.—Because of the solubility of magnesium carbonate in the presence of alkali bicarbonates, it is necessary to precipitate the magnesium as hydroxide. In water treatment, therefore, the magnesium bicarbonate requires double the amount necessary to simply bring it to the carbonate stage (Part I, see page 172).

EXERCISE IX

Permanent Hardness.—Boil in a porcelain dish 500 cc. of the water for about 10 min. and add 25 cc. of $N/10$ "soda reagent" (equal parts of sodium hydroxide and sodium carbonate) and then evaporate further to about one-half volume. Filter, wash and make up to 250 cc. Titrate 100 cc. of this solution with $N/10$ sulfuric acid, using methyl orange as an indicator. The amount of original water used is then 200 cc., since the 100 cc. used is two-fifths of the 250 cc., and consequently two-fifths of the 500 cc. The difference between this titration and the amount of acid equivalent to 10 cc. $N/10$ soda reagent multiplied by (5×5) represents the equivalent of permanent hardness in parts per million measured in terms of calcium carbonate. Calculate also the amount in parts per million of the sodium sulfate formed by the reaction and refer the result for use under Exercise XIV.

In the reaction, as with soda reagent, for example,

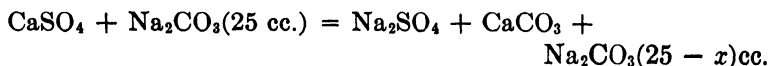

it is seen that part of the $N/10$ sodium carbonate has changed over to sodium sulfate. The extent of this change is dependent, of

course, upon the quantity of calcium sulfate, magnesium sulfate, etc., present in the water and the measure of the change is indicated by the titration of the filtrate. It is to be noted again that, in so far as magnesium sulfate may be present, the magnesium carbonate formed is soluble to a considerable extent, hence the more insoluble magnesium hydroxide is provided for by the use of the soda reagent, which is part sodium hydroxide.

Some waters will give a titration in the filtrate which is greater in amount than the quantity of soda reagent added. This condition is designated as negative hardness.

EXERCISE X

Negative Hardness.—Throughout the drift region of the Mississippi Valley a very large percentage, especially of the deep wells, yield waters of Class I, as described on page 165. Such waters have no sulfates of calcium or magnesium present. They have, however, some free sodium bicarbonate instead, which indicates that some such reaction as indicated in Exercise IX above has taken place while the water was percolating through the ground. The treatment prescribed above, therefore, would result simply in the addition of more alkali. Hence, the excess of acid required over the 10 cc. of alkali added would be a measure of the free sodium carbonate or "negative hardness" present. Multiplying by (5×5.3) would give the weight in milligrams per liter of Na_2CO_3 . Calculate the negative hardness in terms of calcium carbonate in order to obtain the temporary hardness.

EXERCISE XI

Total Hardness.—The total hardness of a water may be derived (a) from the data which have resulted from Exercises VII and IX above, and (b) from the soap test. It is well to use both sources of information as a check.

a. Under Exercise VII there will be measured the amount of temporary or bicarbonate hardness; that is, the amount of calcium, magnesium and iron present as bicarbonates, but measured all together in terms of calcium carbonate by the titration with $N/10$ hydrochloric acid or sulfuric acid.

Under Exercise IX there will be indicated the amount of sulfate or chloride hardness; that is, the amount of calcium,

magnesium or iron which may be present in the form of the sulfates or chlorides of these elements, but measured again in the equivalent of calcium carbonate. Be sure that Exercise X has been taken into this account, for, if free sodium bicarbonate is present, there will be no permanent but only temporary hardness to enter into the total hardness. The sum of the temporary hardness and permanent hardness (if any), given in terms of calcium carbonate, represents the total hardness.

b. Make a determination of total hardness by means of the standard soap solution as follows:

Measure 50 cc. of the water into a No. 3 beaker, add a few drops of methyl orange and titrate with *N*/10 sulfuric acid to the end point. Transfer the water thus neutralized to the shaking bottle used for the soap test and run in, from a burette, the standard soap solution, a few tenths of a cubic centimeter at a time, shaking vigorously after each addition. The end point is taken in the same manner by noting where, upon laying the bottle on its side after shaking, the lather remains for 5 min. With water, containing magnesium salts, care must be taken, to avoid mistaking the salts-of-magnesium end point. After the titration is apparently finished, read the burette and add 5 cc. of soap solution. If the end point was due to magnesium the lather disappears. Continue the addition of soap solution until the true end point is reached.

From the standardization curve for the soap solution read the amount of hardness as parts per million in terms of calcium carbonate. How does the amount compare with the total hardness as derived under (a) above?

EXERCISE XII

Determination of Total Sulfates.—A rapid, accurate method for the determination of sulfate in boiler waters has become particularly important in view of recent work which indicates the necessity of maintaining a definite sulfate content in the water to act as a preventive measure for boiler embrittlement as specified by the American Society of Mechanical Engineers and the American Society for Testing Materials. Since the sulfate in the water is already in solution form, an exceedingly short procedure may be followed with the turbidimeter and results

obtained in approximately 5 min. The usual method for reporting sulfate values is in terms of parts per million of sodium sulfate.

If the boiler water contains any material in suspension, it should be filtered. Measure a suitable portion into a 250-cc. beaker, depending upon the approximate sulfate content of the water.

Sodium Sulfate Parts per Million	Volume of Sample, Cubic Centimeters
100- 180	150
160- 310	100
260- 510	60
400- 770	40
640-1,240	25
800-1,550	20
1,000-1,930	16
1,600-3,100	10

Acidify the sample in the beaker with a solution of hydrochloric acid (1 part concentrated HCl to 1 part water). Place a piece of blue litmus paper in the solution and add the acid slowly, stirring until a red coloration of the paper is obtained. Avoid an excess of acid.

Add 25 cc. of the NaCl-HCl solution and dilute with distilled water to exactly 200 cc. Place the solution in an Erlenmeyer flask, add one measure of barium chloride crystals and shake the solution vigorously for about 1 min. Then place the entire 200 cc. in the turbidimeter and take readings in the same manner as explained for sulfur in coal and coke.

Refer to the chart on page 262 for the weight of sulfur indicated by the turbidimeter reading. Calculate to sodium sulfate thus

$$32:142 :: \text{weight of S}:\text{Na}_2\text{SO}_4$$

EXERCISE XIII

Determination of Total Chlorides.—Measure accurately 50 cc. of water by means of a 50-cc. pipette into a porcelain dish. Add about 1 cc. of potassium chromate solution and titrate with *N*/100 silver nitrate solution, until the yellow color gives place to the first permanent trace of reddish brown. Do not wait for a red tint to appear. Fill another porcelain dish with 50 cc. of distilled water and add 1 cc. of the indicator. Use this as a

standard of comparison. The first tinge of brownish red that can be distinguished in the titrated solution is to be taken as the end point.

The reactions involved are

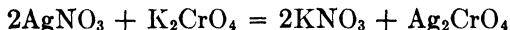

The silver chromate is a red precipitate, but as long as there is any soluble chloride in solution this breaks up the chromate as follows:

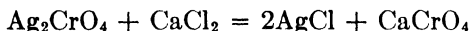

Thus, the first permanent tinge of pink shows that the chloride has all been precipitated. From the volume of silver nitrate used to this point, calculate the weight of chloride in the 50 cc. taken, thus:

$$\text{volume } N/100 \text{ AgNO}_3 \times 0.0003545 = \text{weight Cl in 50 cc.}$$

$$0.0005845 \times \text{volume } N/100 \text{ AgNO}_3 = \text{weight NaCl in 50 cc. of the water.}$$

Multiplying further by 20 will give the weight per liter. From this is indicated, by referring to milligrams, the milligrams per liter or parts per million.

EXERCISE XIV

Total Alkalies.—The total alkalies are considered as being made up of all the sulfate not combined as permanent hardness and all of the chlorides. It is true that small amounts of other alkali salts, as sodium nitrate, are present and occasionally some of the chloride is present as magnesium or calcium chloride; but, for the scope of this work and for ordinary technical requirements, it is quite sufficient to consider the total alkalies as being constituted as above indicated.

Procedure.—From the total sulfate as determined under Exercise XII and calculated to sodium sulfate, subtract the sulfate hardness as found under Exercise IX and which was there calculated also to the equivalent of sodium sulfate for this purpose. The remainder is the amount of alkalies existing in the water in the form of sodium sulfate. To the above should be added the total chloride results under Exercise XIII, calculated to sodium chloride.

If free sodium carbonate or negative hardness was developed under Exercise X then this also, in the form of equivalent sodium carbonate, should be added as a third constituent of the alkalies.

The sum of these various constituents, referred in each instance to parts per million, is to be taken as the total alkalies in parts per million. Calculate this sum also to grains per U. S. gallon.

EXERCISE XV

Examination of a Treated Water.—1. If the water has been undertreated, it is possible to determine *as with an untreated water* the amounts of lime and soda still needed to soften water.

2. In case excess of soda ash has been added, the permanent hardness will be *negative*; and, if the water has no sodium carbonate present originally, 1.06 times the negative hardness expressed as parts per million of calcium carbonate represents the excess of sodium carbonate which has been added to the water.

3. In most cases, however, a treated water is alkaline to phenolphthalein, in which case 200 cc. is titrated with *N/10* sulfuric acid, to the end point with phenolphthalein and then, on to the end point, with methyl orange.

If the amount of acid needed to give the end point with the phenolphthalein is more than half that which is needed to give the end point with methyl orange, an excess of lime is present. If the difference between the two quantities be subtracted from the number of cubic centimeters for the phenolphthalein end point multiplied by 25, the result shows the calcium carbonate equivalent in parts per million of the excess of pure lime (CaO). This equivalent multiplied by 0.56 gives the parts per million of CaO. The result multiplied by 0.0583 gives the amount in pounds per 1,000 gal.

EXERCISE XVI

Examination of Boiler Concentrates.—1. The sample of boiler concentrate should be representative of the water in the boiler. It is usually obtained at the water column, after blowing out sufficient water to clean out the pipes. However, if a continuous blow-down is used in connection with heat exchangers, it may be obtained from this point. Ordinarily it is desirable to take the sample through a cooling coil to avoid flashing into steam and a

consequent concentrating of the dissolved salts. If the sample contains much suspended matter it should be filtered. Care should be taken during the filtering to see that the water is not exposed to the air any more than necessary, since the carbon dioxide from the air will combine with alkali in the water.

Titrate 200 cc. of the boiler water with $N/10$ sulfuric acid to the end point of phenolphthalein and then continue to the end point of methyl orange with the same sample.

The following outline will be found helpful in determining the various types of alkalinities which are present:

Letting Pt stand for the titration when using *phenolphthalein* and Mo for the titration when using *methyl orange*, then,

When $Pt = Mo$, there are present hydroxides only.

When $Pt > \frac{1}{2}Mo$, there are present hydroxides and normal carbonates.

When $Pt = \frac{1}{2}Mo$, there are present normal carbonates only.

When $Pt < \frac{1}{2}Mo$, there are present normal carbonates and acid carbonates.

When $Pt = 0$ the Mo titration represents acid carbonates only.

When a 200-cc. sample is titrated with $N/10$ acid then

$$2 (Mo - Pt) \times 26.5 = \text{p.p.m. Na}_2\text{CO}_3$$

$$(2 Pt - Mo) \times 20 = \text{p.p.m. NaOH}$$

$$Mo \times 26.5 = \text{p.p.m. total alkalinity expressed as Na}_2\text{CO}_2$$

2. If the water contains much organic matter and has a dark color there is a possibility of an error in the methyl orange end point. In order to analyze such waters, a modification of the Winkler method¹ should be used.

Titrate 200 cc. of the boiler concentrate to the end point of phenolphthalein. Call the number of cubic centimeters used A . To a second sample of 200 cc. add about 10 cc. (roughly) of a neutral solution of 10 per cent barium chloride. Stopper the flask and let stand for about 10 min. Then titrate to the end

¹ Cf. TREADWELL and HALL, "Analytical Chemistry," 2d ed., vol. II, p. 486: John Wiley & Sons, Inc., New York, 1928.

point of phenolphthalein. Call the number of cubic centimeters used B .

Then

$$B \times 20 = \text{p.p.m. NaOH}$$

$$2(A - B) \times 26.5 = \text{p.p.m. Na}_2\text{CO}_3$$

$$(2A - B) \times 26.5 = \text{p.p.m. total alkalinity expressed as Na}_2\text{CO}_3$$

If phosphates are present these methods will not give the correct results, since the alkaline salts of phosphates also enter into the reactions. Consequently, it would be well to test for phosphates in the boiler concentrates.

EXERCISE XVII

Determination of Soluble Phosphate in Boiler Concentrates.—Soluble phosphates are maintained in the boiler for the prevention of embrittlement and scale. The amounts necessary are small, usually being below 100 p.p.m. of phosphate ions. The method used for determining the phosphate involves the precipitation as ammonium phosphomolybdate, washing the precipitate free from acid, dissolving it in an excess of standard sodium hydroxide solution and titrating the excess with a standard solution of nitric acid.

The following solutions are required:

- a. A 3 per cent solution of ammonium molybdate obtained by dissolving 30 grams of the salt in 1 liter of water. 1 cc. of this solution will precipitate approximately 0.001 gram of phosphate ion.
- b. A solution of ammonium nitrate obtained by dissolving 340 grams of the salt in 1 liter of water.
- c. Nitric acid solution, 25 per cent.
- d. A wash liquid (A) containing 50 grams ammonium nitrate and 40 cc. of nitric acid dissolved in 1 liter of water.
- e. Wash liquid (B) containing 50 grams ammonium nitrate dissolved in 1 liter of water.
- f. $N/10$ NaOH solution.
- g. $N/10$ HNO₃ solution.

Place a sample of 200 cc. of the boiler concentrate in a 500-cc. Erlenmeyer flask, add 40 cc. of the ammonium nitrate solution (b) and 20 cc. of the nitric acid solution, (c). Heat the solution until

bubbles begin to rise. Then add slowly 40 cc. of the ammonium molybdate solution and stir the solution vigorously. Filter after about 15 min. and wash the precipitate with solution *A*, and then with solution *B* until the washings no longer show an acidic reaction.

Transfer the filter and precipitate to the Erlenmeyer flask in which the precipitation took place. Add an excess of *N*/10 NaOH, stir until the precipitate is completely dissolved, or the yellow color disappears. Then titrate the excess of alkali with *N*/10 nitric acid using phenolphthalein as an indicator. Calculate the phosphate present as parts per million, using 1 cc. *N*/10 NaOH = 0.000414 gram PO₄.

EXERCISE XVIII

Summary of Results and Calculations.—The character of a water is shown by assembling in tabular form the various ingredients grouped in a manner to indicate the total soluble and insoluble ingredients, as in the accompanying outline. This summary calls for the various results in grains per gallon, and the order and grouping are those of the Exercises VI to XVI.

The calculations for the requisite amount of reagents to remove the scaling ingredients involve simply the calculation from the

TABLE XXXV.—SHOWING THE RATIO OF REAGENT TO INCRUSTING MATERIAL REQUIRED FOR WATER TREATMENT

Weight of 1 U. S. gal. of water at 65°F..... 58,330 grains

1 part:1,000,000::*x*: 58,330

Hence, *x* grains per gallon = 0.05833 × parts per million.

1 part free CO₂ requires 1.27 parts CaO and leaves no soluble material

1 part Na₂CO₃ requires 0.53 part CaO and leaves 1 part soluble material

1 part CaCO₃ requires 0.36 part CaO and leaves no part soluble material

1 part CaSO₄ requires 0.78 part Na₂CO₃ and leaves 1.04 parts soluble material

1 part CaCl₂ requires 0.96 part Na₂CO₃ and leaves 1.05 parts soluble material

1 part MgCO₃ requires 1.33 parts CaO and leaves no part soluble material

1 part MgSO₄ requires 0.88 part Na₂CO₃ + 0.47 part CaO and leaves 1.18 parts soluble material

1 part MgCl₂ requires 1.11 parts Na₂CO₃ + 0.59 part CaO and leaves 1.22 parts soluble material

1 part acid (H₂SO₄) requires 0.57 part CaO + 1.08 parts Na₂CO₃ and leaves 1.45 parts soluble material

SUGGESTED FORM FOR REPORTING RESULTS OBTAINED IN THE PRECEDING EXERCISES

Analysis of Boiler Water from (raw water source, treated water, boiler concentrates, etc.).....

No. Sample taken..... 19..

	Requiring for treatment of 1,000 gal.			
	Grains per gallon	Parts per million	Pounds of slaked lime	Pounds of 99.0 per cent soda ash
Free CO ₂ as CaCO ₃ equivalent.....				
Total alkalinity as CaCO ₃ equivalent.....				
Temporary hardness as CaCO ₃ equivalent.....				
Negative hardness as CaCO ₃ equivalent.....				
Magnesium as CaCO ₃ equivalent.....				
Permanent hardness as CaCO ₃ equivalent.....				
Total scale-forming material.....				
Sulfates as Na ₂ SO ₄				
Chlorides as NaCl.....				
Sodium hydroxide as NaOH.....				
Sodium carbonate as Na ₂ CO ₃				
Total alkalinity as Na ₂ CO ₃ (boiler concentrates only).....				
Ratio: $\frac{\text{Na}_2\text{SO}_4}{\text{total alkalinity Na}_2\text{CO}_3}$ (boiler concentrates only).....				

Remarks:.....

By.....

determined equivalent of calcium carbonate over to the proper reacting substance, thus:

Since one equivalent of excess CO₂, one equivalent of temporary hardness, or one equivalent of magnesium requires one equivalent of calcium oxide for its removal from the water, 0.56 times the sum of the calcium carbonate equivalent of excess carbon dioxide, temporary hardness, and magnesium represents the number of

parts per million of pure lime (CaO), necessary to remove these impurities.

The calcium carbonate equivalent of the permanent hardness multiplied by 1.06 is the number of parts per million of sodium carbonate (Na_2CO_3), necessary to remove the permanent hardness; 0.0583 times the quantities in parts per million \times one-seventh gives the pounds per 1,000 gal. needed. The results above are for pure lime and sodium carbonate. Commercial lime and soda ash must be analyzed to determine the amounts of pure lime and sodium carbonate which they contain.

CHAPTER XXXII

EXAMINATION OF LUBRICANTS

Viscosity.—The specific viscosity of a liquid is the time taken for a given quantity to flow through an orifice, as compared with water, at a given temperature. A pipette graduated to deliver 100 cc. of water from the bulb alone, that is, not including the lower stem, in 34 sec. is the simplest form of apparatus for such a purpose. In oil work an arbitrary factor is obtained which varies with the type of instrument employed, hence the viscosity number and the name of the instrument by which it was determined must be coupled together. The Engler viscosimeter is standard with the Teutonic and Scandinavian countries and has been adopted by the International Society for Testing Materials, while in England the Redwood instrument is the standard. The American Society for Testing Materials prescribes (1930 "Standards") that "Viscosity shall be determined by means of the Saybolt Standard Universal Viscosimeter." The most essential parts, omitting the external jacketing bath, are shown in Fig. 93. There is a standard oil tube *A*, fitted at the top with an overflow cup *B*. The tube is a small outlet of definite shape and dimension. The lower end of the larger tube is closed by a cork forming an air chamber which prevents the oil from flowing through the standard outlet orifice till the cork is removed. The receiving flask has a capacity at the mark of 60 cc.

Viscosity numbers may be determined at 100, 130 or 210°F. The temperature of the oil in the standard tube is held constant by means of the surrounding bath which is preferably of oil. The temperature of the sample must not vary from the test temperature by more than $\pm 0.2^\circ\text{F}$. when the test is made.

To make a test, heat the oil bath to the desired temperature and clean out the oil receptacle, pouring some of the oil to be tested through the tube and allowing it to drain out below. The oil

should be poured through a 100-mesh wire strainer to prevent sediment and lint from entering the standard tube.

After inserting the stopper at the lower end of the air chamber, fill the standard tube with the oil to be tested. It will save time to have it already heated to not more than 3°F. above the

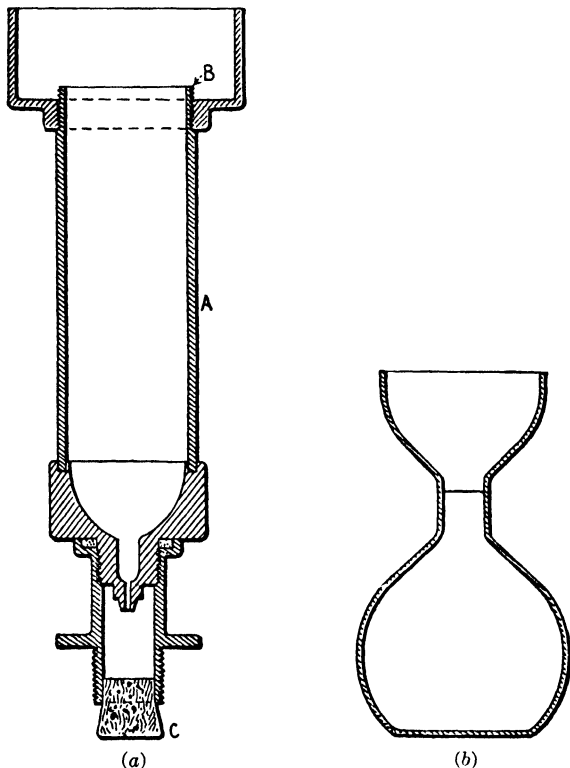

FIG. 93.—Essential features of the Saybolt standard universal viscosimeter. (a) Sectional view of standard oil tube. (b) Receiving flask.

point desired before adding it to the tester. Oil should be added until it ceases to overflow into the cup at *B*.

Both the bath and the oil sample should be well stirred. When equilibrium at the desired temperature has been established, remove the thermometer or stirrer from the sample and by means of a pipette withdraw the oil from the overflow cup until the level is below the overflow edge at *B*. Place the 60-cc. flask in

position, quickly remove the cork by jerking a cord attached to it and at the same instant start the stop watch. Stir the liquid in the outer bath maintaining the proper temperature and stop the watch when the bottom of the meniscus reaches the mark. The time in seconds for the delivery of the 60 cc. is the Saybolt Universal Viscosity Number of the oil at the designated temperature of the test.

Flash and Fire Test.—The Cleveland open-cup tester (Fig. 94), is very well suited for determining the flash point of lubricating

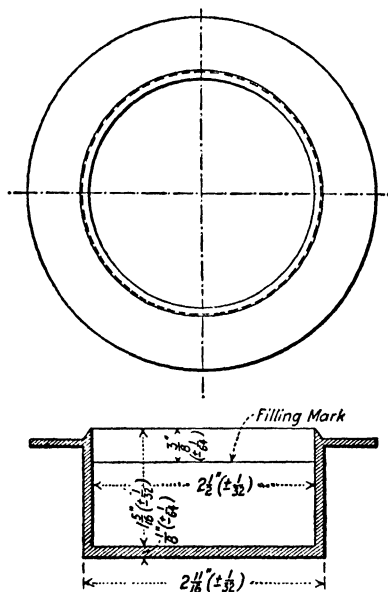

FIG. 94.—Cleveland open cup for determining flash point of lubricating oils.

oils. It has been adopted as the standard by the American Society for Testing Materials. Readings are from 10 to 40° higher than those obtained from the Pensky-Martens closed tester which is very widely used as a standard.¹

¹ The American Society Testing Materials (Committee D-21) has made the Tagliabue instrument the standard for obtaining the flash and fire points by the closed-tester method.

See *Proc. Am. Soc. Testing Materials*, vol. 24, Pt. I, p. 542, 1924, for comparison of flash points by Cleveland open cup and Pensky-Martens closed cup.

The metal cup is filled with the oil to the filling mark, $\frac{3}{8}$ in. below the top edge. Above 75 cc. of oil are required. The cup is placed upon the heating plate (Fig. 95), supported by a tripod ring, in a location free from drafts. A thermometer is suspended in the oil, midway between the center and the inside edge of the cup. The bulb should be within $\frac{1}{4}$ in. of the bottom and entirely submerged in oil. The bulb for this purpose should not be over $\frac{1}{2}$ in. in length.

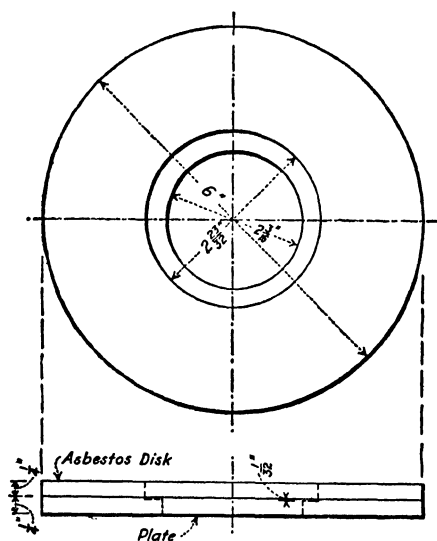

FIG. 95.—Heating plate for open-cup flash test.

Heat by a direct flame, rapidly at first, but slower as the flash point is approached, when a test is made for every 5°F. rise in temperature. The flame for testing is supplied from a glass capillary and should be a small bead-like flame approximately $\frac{5}{32}$ in. in length. It is passed slowly across the center of the cup in the plane of the upper edge of the cup and occupying 1 sec. in the passage.

The temperature when a flame first jumps from the test flame to the oil is called the flash point. A subdued light and freedom from drafts are essential to satisfactory observations.

After the flash point has been obtained the fire point is found by continuing the heating at the rate of 9 to 11°F. per minute,

until a flame is produced which continues to burn at least 5 sec. This temperature is designated as the fire point.

The Conradson Test.¹—Ten grams of oil are weighed into a 25-cc. porcelain crucible which is placed inside of a Skidmore iron crucible approximately 65 mm. in diameter by 37 to 39 mm. high, with one hole in the cover left open. Place these two inside

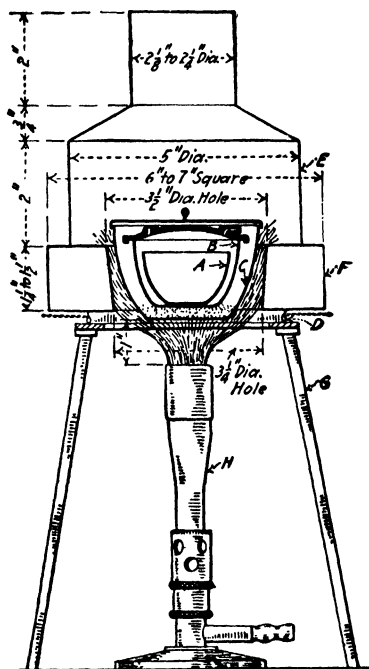

FIG. 96.—Conradson carbon-residue apparatus.

of a second iron crucible approximately 80 mm. in diameter by 50 to 60 mm. high, having also a cover and containing a layer of sand 10 mm. deep. Arrange on a tripod and cover with a hood or inverted assay crucible in such a manner that the heat will be distributed evenly on all sides (see Fig. 96).

Heat by means of a Meker burner, using a large flame, at first, which will envelop the large crucible. When vapors from the oil start to ignite above the crucible, reduce the flame so that the vapors will come off at a uniform rate burning at a height of

¹ Am. Soc. Testing Materials, "Standard Methods," D 189-30.

about 5 cm. above the sheet-iron hood. After the vapors cease, increase the heat as at first and continue for 5 min. The bottom of the large crucible should be red hot. Allow the temperature to reduce before opening, remove the porcelain crucible to a desiccator, cool and weigh. Approximately $\frac{1}{2}$ hr. will be required

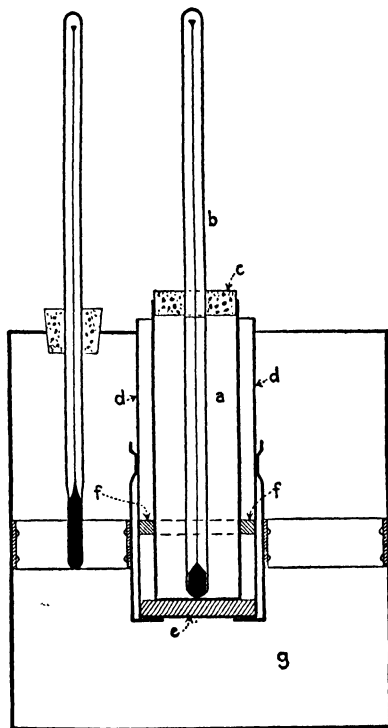

FIG. 97.—Apparatus for cloud and pour test of oils (assembled for cloud test).

for the process when properly regulated. The deposit as percentage of the original sample is designated as carbon residue, from the Conradson test.

Cloud and Pour Points.—The American Society for Testing Materials¹ has adopted the apparatus shown in Fig. 97. The test jar *a* is of clear glass $1\frac{1}{4}$ in. in diameter and $4\frac{1}{2}$ to 5 in. high. It is separated from the jacket *d* by a disk of cork or felt, *e*, $\frac{1}{4}$ in. thick at the bottom, and a ring gasket *f* of cork or

¹ "Standard Methods," D 97-1930.

felt, $\frac{3}{16}$ in. thick, surrounding and clinging to the test jar. The jacket may be of metal or glass and must be water-tight, clear and dry. The jacket is firmly held in a vertical position within a cooling bath *g*, of optional design. The oil to be tested is brought to a temperature about 25°F . above the cloud point and is poured into the test jar to a height of 2 to $2\frac{1}{4}$ in. The test jar is tightly closed by the cork *c*, carrying the test thermometer *b* in a vertical position in the center of the jar with the bulb resting on the bottom of the jar. The jacket is surrounded by a cooling mixture 15 to 30°F . below the cloud point of the oil. At temperature intervals of 2°F . the test jar is removed quickly from the jacket, inspected for cloud and replaced in the jacket. The temperature at which the first appearance of cloudiness or haze in the oil at the bottom of the jar is noted is recorded as the cloud test.

The same apparatus is used for the determination of the pour point, except that the cooling mixture is kept at 15 to 30°F . below the pour point of the oil, and the bulb of the thermometer is immersed only to the point at which the beginning of the capillary is $\frac{1}{8}$ in. below the surface of the oil. The test jar containing oil to a height of 2 to $2\frac{1}{4}$ in. and with the thermometer in place is heated without stirring to 115°F . in a bath maintained at 118°F . and is then cooled in air to 90°F . before placing in the jacket of the cold test bath. Beginning at a temperature 20°F . before the expected pour point, the test jar is removed carefully from the jacket and is tilted just enough to ascertain whether there is a movement of the oil. The complete operation of removal and replacement should not require more than 3 sec. This inspection should be repeated at temperature intervals of 5°F . After paraffin-wax crystals have begun to form, great care must be taken not to disturb the mass of oil or permit the thermometer to shift in the oil. As soon as the oil fails to flow when the jar is tilted, the test jar is held in a horizontal position for exactly 5 sec. If the oil then shows any movement, the test jar is immediately replaced in the jacket. The temperature at which the oil no longer moves when the jar is held in a horizontal position for 5 sec. is the cold test, or solid point. The pour point is taken as the temperature 5°F . above the solid point.

Emulsification.—The emulsification test as adopted by the American Society for Testing Materials,¹ may be summarized as follows:

Twenty cubic centimeters of oil and 40 cc. of distilled water are placed in a 100-cc. graduated cylinder of approximately 1-in. inside diameter, and heated in a water bath at 130°F. A mechanical stirrer is then introduced for 5 min. It should have a speed of 1,500 r.p.m. and the paddle should be entirely submerged. The suggested size of the paddle is $4\frac{3}{4}$ by $1\frac{3}{16}$ by $\frac{1}{16}$ in. attached with its longest dimension in line with the driving shaft. After stirring, the mixture is allowed to stand in the bath at 130°F. At convenient intervals, readings are taken of the volume of clear oil which settles out, noting the point of separation in line with the upper surface of the meniscus.

Calculate the rate of demulsification in cubic centimeters per hour. Note that the average rate is taken, that is, if D is the total volume demulsified at any stage and t the time in minutes from the cessation of stirring, then

$$\frac{D \times 60}{t} = \text{rate of demulsification per hour}$$

It is to be observed that the cylinder readings are from the bottom up, and that D in the above expression is 60 minus the upper surface reading of the emulsion. Hence, if the reading at the end of 1 min. is 40, then the demulsified portion $\times 60 = 1,200$, or the rate of demulsification per hour. This would be the highest possible demulsibility. If the readings showed 10 cc. demulsified at the end of 15 min., the rate would be $10\frac{1}{15} \times 60 = 40$ cc. per hour. A complete table for time and readings from 59 to 40 is a convenience.²

No continuous layer of emulsion shall remain after the specified time. The same test is usually made at 180°F.

The Steam Emulsion Test.³—This test should be applied to all turbine oils and may be used for other lubricating oils. The apparatus (Fig. 98) consists of a steam-generating flask G ,

¹ *Tech. Papers*, Pt. II, p. 248, 1916.

² Am. Soc. Testing Materials, "Standard Methods," Pt. II, p. 258, Table III, 1920.

³ Am. Soc. Testing Materials, "Standard Methods," D 157-28.

heated by a burner; an emulsifying bath *E*, containing the oil sample tube *D*; and the separating bath *H*. Glass battery jars of 3 to 3.5 liters capacity and $7\frac{1}{2}$ to 9 in. in depth may be used for the baths. The oil container is a 25- by 200-mm. test tube graduated from zero to 50 cc. Three liters of water are placed in each bath. The water in the separating bath *H* is heated by steam to 200 to 203°F. and maintained at that point. The

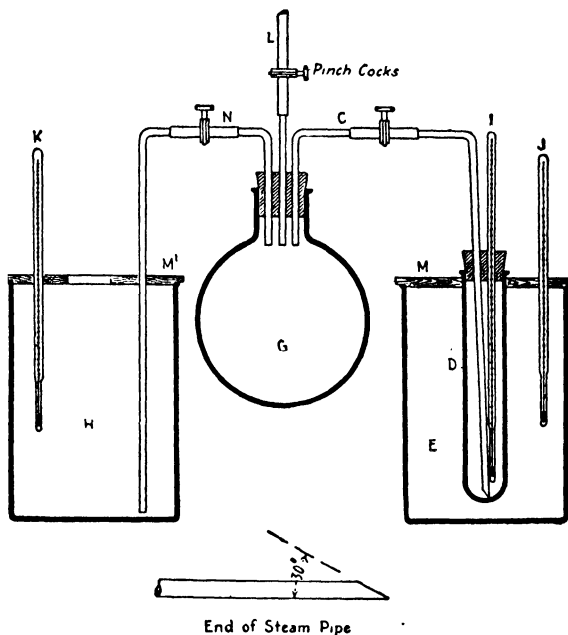

FIG. 98.—Apparatus for steam emulsion test, self-generating steam supply.

temperature of the emulsifying bath is brought within the range 67 to 78°F. at the start and is not thereafter controlled. Twenty cubic centimeters of the oil are poured into the oil container and the cork stopper containing the thermometer is put in place. Both the thermometer and the oil container must be made *chemically clean* before use. The steam delivery tube, which should first be steamed out until all condensation disappears, is then inserted through a *loose* hole in the cork so that the point touches the center of the bottom of the oil container. Steam is then admitted at a rate which will maintain the temperature of

the oil between 190 and 195°F., and steaming is continued until the volume of the oil and the condensate in the oil container is 40 cc. This should require 4 to 6.5 min. The steam delivery tube is withdrawn from the oil at once and a stop watch is started. The container is immediately transferred to the separating bath and the cork and thermometer are taken out. The contents of the oil container are examined every 30 sec., and the volume of separated oil is recorded. The elapsed time in seconds when 20 cc. of oil have separated is reported as the Steam Emulsion Number. In interpreting results, the assumption is made that the rate of separation is directly proportional to the resistance to emulsification of the oil.

Free Acid.—Lubricating oils should be free from sulfuric acid used in refining and also from sulfonates resulting from treatment with acid for the removal of unsaturated hydrocarbons. Fatty acids from the oils used in compounding if present in small amount are not so objectionable.

Weigh 10 grams of oil into an Erlenmeyer flask and add 50 cc. of ethyl alcohol which has had 2 or 3 drops of phenolphthalein added and brought to a very faint pink with *N*/10 potassium hydroxide solution. Heat to boiling and agitate well. Titrate the hot solution with *N*/10 KOH solution.

Calculate the number of milligrams of potassium hydroxide required to neutralize the free acids present per gram of oil. This is the neutralization number and represents the total of the mineral acid and the free fatty acids present in compounded oils.

Where it is desirable to determine the mineral acid alone, the oil is extracted with boiling distilled water and the aqueous extract is titrated with *N*/10 KOH solution using methyl orange as an indicator. Usually a 25- to 50-gram sample of the oil, weighed to 0.1 gram, is shaken vigorously with 100 cc. boiling distilled water in a separatory funnel. The water layer is drained into a 500-cc. casserole. The extraction is repeated twice with 50-cc. portions of distilled water. The combined aqueous extract in the casserole is heated to boiling and a drop of phenolphthalein is added. If the solution does not turn pink, indicating free alkali, the methyl orange indicator is added and the solution is titrated with *N*/10 KOH until the pink color just disappears.

Saponification Number.—The fatty oil may be determined by effecting a complete saponification with a known amount of standard alcoholic potash solution and titrating the unused potash. The solution is made by dissolving 58 grams of stick KOH “purified by alcohol” in 1,000 cc. of pure 95 per cent ethyl alcohol.

Weigh 10 grams of oil into a 350-cc. Erlenmeyer flask and add from a burette 50 cc. of the alcoholic potash solution and 25 cc. of purified or c.p. benzene (C_6H_6). For a straight fatty oil the sample should not be more than 3 to 4 grams. Boil with a reflux condenser of sufficient length and proper regulation of heat so as to avoid loss of the volatile material. Continue the boiling for 3 hr. and add 25 cc. of neutral gasoline. Add 2 or 3 drops of phenolphthalein and titrate with $N/2$ HCl until the pink color is destroyed. A blank determination with the same quantity of alcoholic potash and purified benzene, but without the oil, is made simultaneously in an identical manner. From the difference between the volume of $N/2$ HCl required for the blank and that required for the saponification test, calculate the number of milligrams of potassium hydroxide to saponify 1 gram of the oil. This is the saponification number.¹ For example, each cubic centimeter of $N/2$ HCl is equivalent to 0.02805 gram KOH. Hence,

$$\frac{\text{No. cc. } N/2 \text{ acid} \times 28.05}{\text{Weight of oil taken in grams}} =$$

milligrams KOH per gram of oil taken, or saponification number

For the common fatty oils used in compounding, the average saponification number is 195, that is, for every 0.195 gram of KOH there is 1 gram of fatty oil present in the mixture, hence the percentage of such an oil may be estimated approximately by introducing this factor into the above equation and multiplying by 100, thus:

$$\frac{\text{No. cc. } N/2 \text{ acid} \times 28.05 \times 100}{\text{Weight of oil taken in grams} \times 195} =$$

per cent of fatty oil in the mixture

The percentage of fatty oil in the mixture can be obtained, accurately, only when the saponification number of the fatty

¹ Am. Soc. Testing Materials, Method D 94-28, “Standard Methods.”

oil present is accurately known. Saponification numbers of usual compounding oils are given in Table XXXVI.

Maumené Test.—Weigh into a beaker 50 grams of oil. The beaker should be jacketed or so arranged as to avoid loss of heat by radiation. Take the temperature of the oil and retain the thermometer in the oil as a stirrer. Add from a burette with constant stirring, drop by drop, 10 cc. of concentrated sulfuric acid and note the highest temperature attained. Subtract the temperature of the oil at the start. The rise in temperature in degrees Centigrade is the Maumené number. Its principal value is in the identification of pure fatty oils, but it may be applied also to compounded oils. Consult Table XIII in the Appendix for possible interpretation of the results. It should be noted that the percentage of saponifiable material in the oil must enter into the conclusion as to the type of fatty oil employed in compounding.

TABLE XXXVI.—SAPONIFICATION NUMBERS OF USUAL COMPOUNDING OILS

Fatty Oil	Saponification Number
Lard oil.....	192-198
Tallow.....	193-198
Neat's-foot.....	193-204
Fish.....	140-193
Sperm.....	120-140
Castor.....	176-187
Rapeseed.....	170-179
Soya bean.....	189-197
Peanut.....	186-197
Cotton seed.....	191-197
Blown rapeseed.....	195-216
Blown cotton seed.....	210-225
Degras.....	110-210

Specific Gravity.—The specific gravity of oils may be taken with a hydrometer, Westphal balance or pycnometer. The Baumé hydrometer is the instrument commonly used in connection with industrial oil work. There are two hydrometer scales still in use in testing petroleum products; the Baumé scale for liquids lighter than water, and the A.P.I. scale. By agreement of the American Petroleum Institute, the U. S. Bureau of Mines and the U. S. Bureau of Standards in 1921, only the A.P.I. scale is to be used in

the petroleum industry. These scales are both arbitrarily chosen and bear no obvious relation to the weight as does the specific gravity. Hydrometer readings may be changed to specific gravity by reference to a conversion table ("National Standard Petroleum Oil Tables," U. S. Bureau of Standards, *Circular 154*, or to the abridged Table X in the Appendix), or by the application of the formulas published by the U. S. Bureau of Standards.

$$\begin{aligned} \text{Degrees Baumé} &= \\ & \frac{140}{\text{sp. gr.} \frac{60^\circ}{60^\circ\text{F.}}} - 130 \\ \\ \text{Degrees A.P.I.} &= \\ & \frac{141.5}{\text{sp. gr.} \frac{60^\circ}{60^\circ\text{F.}}} - 131.5 \end{aligned}$$

The standard temperature at which specific gravities are reported is 60°F. and readings taken at other temperatures should be corrected by reference to Table XI in the Appendix.

The Westphal balance (Fig. 99) for light and medium oils is recommended because it combines in a satisfactory manner both convenience and accuracy. It is provided with a beam graduated by notches into 10 equal parts. With the plummet attached in air, the pointer should stand at zero. The heaviest weight placed on the hook at the end of the beam, that is, when located at what would be equivalent to the tenth notch, will exactly counter-balance the plummet when suspended in distilled water at 60°F. The pointer should swing equal distances above and below the zero point or come to a rest at zero when adjusting the balance with the plummet in water. The three other weights are respectively equal to $\frac{1}{10}$, $\frac{1}{100}$ and $\frac{1}{1000}$ of the weight of the largest one; hence, their positions on the beam give readings directly in the four decimal places. In testing a liquid, the plummet should be immersed so that on the upward swing it will not come above the liquid. The temperature of the liquid

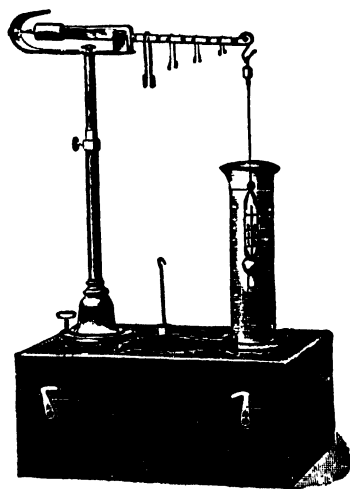

FIG. 99.—Westphal balance.

should be carefully taken and, if different from 60°F., the specific gravity reading should be corrected to that temperature.

The reading of the weights is taken from their positions on the beam in the order of their size. For example, if the heaviest weight is at 7, the next at 4, the third at 9, and the smallest at 2, the specific gravity reading is 0.7492.

If the oil is thick, it should be warmed to allow free movement of the float. The temperature must then be read and corrected for. See tables of specific gravities for oils and corrections for temperature, Tables X, XI and XII of the Appendix. This would apply also where the hydrometer is the apparatus used.

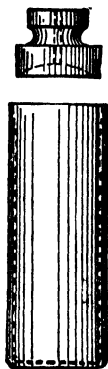

FIG. 100.
Specific gravity bottle, Hubbard type.

For oils and tars too heavy for the Westphal balance and for pitches which must be softened for pouring, the pycnometer method is advisable. A special form of instrument of the Hubbard type is recommended.¹ The main features of this pycnometer (Fig. 100) are its straight sides making it easy to clean, and a stopper with a large capillary, 1.6-mm. bore, with a concave space on its lower surface to facilitate the escape of air bubbles. The weight of the clean, dry apparatus *a* is obtained, also the weight *b* of the apparatus full of recently boiled distilled water cooled to 25°C. These values are constants and need to be determined but once. The weight of the pycnometer full of oil *c* at 25°C. will then give the necessary data for the specific gravity, thus:

$$\frac{c - a}{b - a} = \text{specific gravity of the oil}$$

Of course for very heavy material such as pitch, where it is desired to only partially fill the receptacle with the sample, the pycnometer method is still applicable. The pitch is melted and a portion poured into the apparatus, being careful to avoid smearing the sides. The weight of the apparatus thus partially filled and brought to room temperature is designated as *d*.

¹ HUBBARD, PREVOST, A useful form of pycnometer for determining the specific gravity of semi-solid bitumens, *Jour. Ind. Eng. Chem.*, vol. 1, p. 475, 1909.

Then by completing the filling with water we have the weight e , hence:

$$\frac{(d - a)}{(b - a) - (e - d)} = \text{specific gravity of the sample taken}$$

Color.—The color of a lubricating oil is determined by comparing a sample of the oil contained in a glass jar, 33 mm. inside diameter by 5 in. in height, with color standards established by

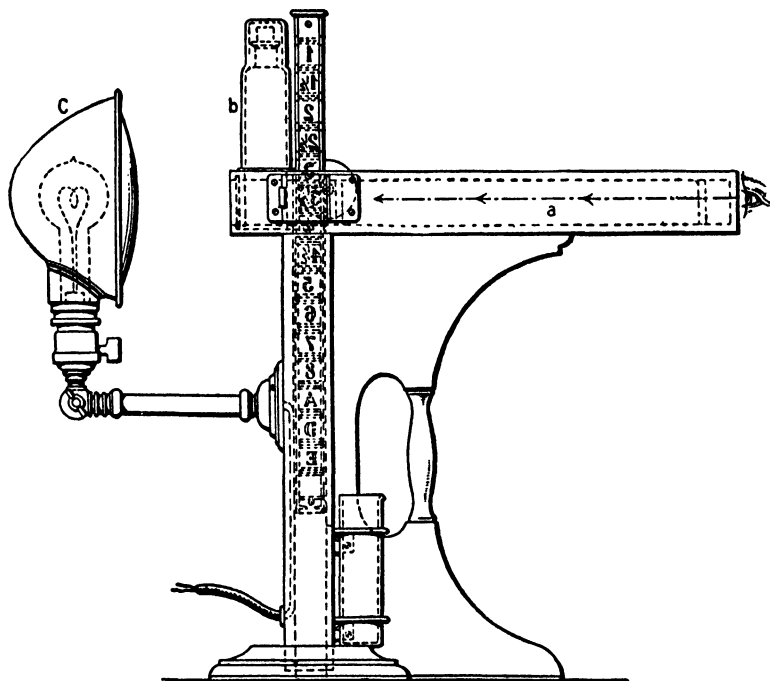

FIG. 101.—Union colorimeter for comparing colors of lubricating oils.

the American Society for Testing Materials (Method D 155-23T) by means of the Union colorimeter (Fig. 101).

Grease Examination.—The important properties of a grease are its melting point, consistency and chemical composition, *i.e.*, water and ash content, and content and kind of soap, filler, fatty oil, mineral oil and free fatty acids. A detailed description of all the necessary tests is beyond the purpose of this text. However, the following brief summary will give a general knowl-

edge of the procedures. The student should refer to the most recent standards of the American Society for Testing Materials¹ for complete details of these tests.

Melting Point.—The melting point is a very important test, especially for all kinds of cup greases, for it gives an indication of the coefficient of friction. The method usually used for cup greases is that of Gillett.² A piece of open glass tubing about 8 cm. long and 4 mm. inside diameter is stuck into the grease so that a plug of grease 1 cm. long is left in the glass tube. The tube is then attached to a thermometer by a rubber band so that the grease plug is even with the bulb. The thermometer and attached tube are immersed in a beaker of water so that the bottom of the plug is 5 cm. below the surface and the water is then heated at a rate of 3 to 4°C. per minute. When the melting point is reached, the plug, which is under a pressure of 5 cm. of water, is forced rapidly up the tube.

The melting point of petrolatum and of heavy greases may be determined as follows: The sample of petrolatum is slowly heated in a casserole to 200°F. and is then cooled to 15°F. above the expected melting point. A standard wax melting-point thermometer is then chilled to 40°F., wiped dry, and is quickly thrust into the sample of petrolatum, so that the lower half of the bulb is submerged. The thermometer is quickly removed and held vertically until the surface of the grease dulls. It is then placed in a water bath at 60° for 5 min. The thermometer is then fixed in a test tube in a beaker of water so that the bottom of the test tube is 15 mm. above the bottom of the beaker and at least 75 mm. below the surface of the water. The bottom of the thermometer should be about 15 mm. above the bottom of the test tube. The water bath is heated at the rate of 2 to 3°F. per minute and the temperature at which the first drop of petrolatum leaves the thermometer is taken as the melting point. This method cannot be used for cup greases since the preliminary melting alters the true melting point.

¹ A.S.T.M. designation D 127-30 Melting point of petrolatum.
A.S.T.M. designation D 217-27T Penetration of greases and petrolatum.
A.S.T.M. designation D 128-27 Analysis of grease.
A.S.T.M. designation D 95-24 Water in petroleum products.

² *Jour. Ind. Eng. Chem.*, Vol. I, p. 351, 1909.

Consistency.—The consistency of a grease depends upon the soap content, kind of fat, water content, the metal of the soap and the method of mixing. The working or stirring of a sample after pouring alters its consistency. This property even changes slowly on standing. The consistency of a grease is not, therefore, maintained within narrow limits. The method adopted as standard involves the uses of the penetrometer apparatus usually used in testing asphalt. Consistency is expressed in terms of the penetration in the grease of a 90° cone of specified weight, in 5 sec., at 77°F. The determination of the unworked consistency, which is of practical importance for hard greases, is made on the undisturbed grease in its original container. The determination of the worked consistency, which is of importance for cup greases, is made after forcing the grease a prescribed number of times through a perforated plate in a grease worker at 75°F.

Consistency is also measured in terms of plastic flow through an orifice in a modified plastometer.

Water Content.—Water is determined by distilling a mixture containing a 100-cc. sample of grease and an equal volume of petroleum ether in a round-bottom flask connected by an offset tube to a vertical condenser beneath which is a graduated glass trap. The water collects in the bottom of the trap tube and the volume is read directly.

Ash Content.—A 2- to 5-gram sample is weighed to 0.1 gram in a tared porcelain crucible. The combustible matter is burned off slowly, and the residue is then ignited until free from carbonaceous matter. The crucible is cooled in a desiccator and weighed. Carbon occluded in fusible alkaline ash and incompleteness of the conversion of calcium carbonate to calcium oxide are important sources of error.

A qualitative examination of the ash will give valuable information regarding the metals present. A fusible ash readily soluble in water to give an alkaline solution indicates sodium and/or potassium. An infusible ash, slightly soluble in water to give an alkaline solution, indicates calcium and possibly magnesium and aluminum. An ash which is yellow when hot indicates zinc. An ash which is yellow when cold, often with the presence of metallic globules, indicates lead.

Free Alkali and Free Acid.—A 10- to 30-gram sample of grease is weighed into a small beaker, dissolved by stirring in 75 cc. of petroleum ether and is then washed into a 250-cc. Erlenmeyer flask with a small quantity of petroleum ether. The beaker is rinsed with 50 cc. of neutral 50 per cent alcohol, the rinsings being poured into the flask. A few drops of phenolphthalein are added. If the alcoholic layer turns pink, 10 cc. of $N/2$ HCl are added and the solution is boiled for 10 min. on a hot plate to expel CO_2 . The excess acid is then titrated with $N/2$ KOH and the free alkalinity is calculated as the hydroxide of the predominating base. When alkaline-earth carbonates are present as fillers, as indicated by evolution of a large amount of CO_2 , a larger quantity of standard acid must be used.

If the original alcoholic layer does not turn pink, the solution is titrated in the cold with $N/2$ KOH, shaking well after each addition. The free acidity is calculated as oleic acid. When soaps of iron, zinc, aluminum or other weak bases are present, the determination of free acid is not possible since the soaps react with KOH.

Filler, Soap, Fatty Oil, and Petroleum Oil and Unsaponifiable Matter.—An 8- to 30-gram sample of grease weighed to 0.1 gram is shaken with 75 cc. of petroleum ether and 50 cc. of 10 per cent HCl until the grease is completely decomposed. The mixture is then filtered through a tared Gooch crucible. The solid material retained by the crucible is rinsed with petroleum ether and alcohol, dried at 120°C . and weighed. This material is filler and may consist of asbestos, talc, mica, yarn, gypsum, graphite, wood dust, etc. When gypsum is present as a filler, the results of this procedure will be too low, due to the solubility of calcium sulfate in the hydrochloric acid. In that case, a 5-gram sample of the grease is warmed with 50 cc. of petroleum ether and 25 cc. of concentrated HCl, until all the gypsum is dissolved. The aqueous layer is separated and the sulfate content is determined gravimetrically by precipitation as barium sulfate. The gypsum content is calculated as $\text{CaSO}_4 \cdot 2\text{H}_2\text{O}$.

The aqueous layer of the filtrate is then separated from the oily layer by means of a separatory funnel. The oil layer is washed three times with 25-cc. portions of water to remove HCl and the washings are added to the aqueous layer which is then

extracted twice with 20-cc. portions of petroleum ether. It is then set aside for qualitative test for glycerine. The two washings are combined and are rinsed with small portions of water, which are rejected. The rinsed petroleum ether washings are then added to the oily layer. This combined petroleum ether extract, containing the fatty acids, fatty oil, and petroleum oil, is titrated with $N/2$ alcoholic KOH and the fatty acids are calculated, using 200 as the average neutralization value, *i.e.*, assuming that 1 gram of the fatty acids requires 200 mg. of KOH for exact neutralization. The lower alcoholic layer is then separated and the petroleum ether layer is washed three times with 30, 25 and 20 cc. of neutral 50 per cent alcohol to remove potassium soaps. These washings are added to the alcoholic layer which is then extracted with 25 cc. of petroleum ether. This petroleum ether washing is added to the main oily extract. This then contains free fat, petroleum oils and unsaponifiable matter. It is concentrated by evaporation to 125 cc. in a 300-cc. Erlenmeyer flask and is then boiled for $1\frac{1}{2}$ hr. under a condenser with 10 cc. of $N/2$ alcoholic KOH and 50 cc. of neutral 95 per cent alcohol to effect the saponification of the fat. The uncombined alkali is then titrated with $N/2$ HCl. The alkali consumed is corrected by that consumed in a blank determination, and the percentage of free fat is calculated, using 195 as the average saponification value of the fat.

The alcoholic layer is separated and the oily layer is washed with 30- and 20-cc. portions of 50 per cent alcohol. These washings are added to the alcoholic layer, and the combined alcoholic solution is extracted once with a small quantity of petroleum ether, which is then combined with the oily solution. This solution now contains the "petroleum oils plus unsaponifiable matter," which is determined by evaporating the petroleum ether in a weighed beaker and weighing the residue.

The viscosity of the petroleum oil may be approximately determined by use of a 2- or 5-cc. pipette which has been standardized against oils of known viscosities.

Further information regarding the fatty acid soaps and fatty oils present may be obtained by separating the free fatty acids from the two alcoholic extracts and determining their neutralization equivalent, iodine number, etc.

For dark greases, containing residuum, asphalt, tars, etc., the grease sample is first heated in a porcelain dish with 10 grams of granulated KHSO_4 and 10 grams of ignited dry sand, and then the mixture is extracted with petroleum ether in a Soxhlet extractor. The petroleum ether extract containing the soap, fatty oil, free fatty acids and petroleum oil is then carried through the usual procedure. The insoluble residue contains the filler and the asphaltic material, the latter of which may be separated and determined by extraction with carbon disulfide.

APPENDIX

TABLE I.—INTERNATIONAL ATOMIC WEIGHTS FOR 1931¹

Element	Symbol	Atomic number	Atomic weight	Element	Symbol	Atomic number	Atomic weight
Aluminum.....	Al	13	26.97	Molybdenum....	Mo	42	96.0
Antimony.....	Sb	51	121.76	Neodymium.....	Nd	60	144.27
Argon.....	A	18	39.944	Neon.....	Ne	10	20.183
Arsenic.....	As	33	74.93	Nickel.....	Ni	28	58.69
Barium.....	Ba	56	137.36	Nitrogen.....	N	7	14.008
Beryllium.....	Be	4	9.02	Osmium.....	Os	76	190.8
Bismuth.....	Bi	83	209.00	Oxygen.....	O	8	16.0000
Boron.....	B	5	10.82	Palladium.....	Pd	46	106.7
Bromine.....	Br	35	79.916	Phosphorus.....	P	15	31.02
Cadmium.....	Cd	48	112.41	Platinum.....	Pt	78	195.23
Calcium.....	Ca	20	40.08	Potassium.....	K	19	39.10
Carbon.....	C	6	12.00	Praseodymium..	Pr	59	140.92
Cerium.....	Ce	58	140.13	Radium.....	Ra	88	225.97
Cesium.....	Cs	55	132.81	Radon.....	Rn	86	222
Chlorine.....	Cl	17	35.457	Rhenium.....	Re	75	186.31
Chromium.....	Cr	24	52.01	Rhodium.....	Rh	45	102.91
Cobalt.....	Co	27	58.94	Rubidium.....	Rb	37	85.44
Columbium.....	Cb	41	93.3	Ruthenium.....	Ru	44	101.7
Copper.....	Cu	29	63.57	Samarium.....	Sm	62	150.43
Dysprosium.....	Dy	66	162.46	Scandium.....	Sc	21	45.10
Erbium.....	Er	68	167.64	Selenium.....	Se	34	79.2
Europium.....	Eu	63	152.0	Silicon.....	Si	14	28.06
Fluorine.....	F	9	19.00	Silver.....	Ag	47	107.880
Gadolinium.....	Gd	64	157.3	Sodium.....	Na	11	22.997
Gallium.....	Ga	31	69.72	Strontium.....	Sr	38	87.63
Germanium.....	Ge	32	72.60	Sulfur.....	S	16	32.06
Gold.....	Au	79	197.2	Tantalum.....	Ta	73	181.4
Hafnium.....	Hf	72	178.6	Tellurium.....	Te	52	127.5
Helium.....	He	2	4.002	Terbium.....	Tb	65	159.2
Holmium.....	Ho	67	163.5	Thallium.....	Tl	81	204.39
Hydrogen.....	H	1	1.0078	Thorium.....	Th	90	232.12
Indium.....	In	49	114.8	Thulium.....	Tm	69	169.4
Iodine.....	I	53	126.932	Tin.....	Sn	50	118.70
Iridium.....	Ir	77	193.1	Titanium.....	Ti	22	47.90
Iron.....	Fe	26	55.84	Tungsten.....	W	74	184.0
Krypton.....	Kr	36	82.9	Uranium.....	U	92	238.14
Lanthanum.....	La	57	138.90	Vanadium.....	V	23	50.95
Lead.....	Pb	82	207.22	Xenon.....	Xe	54	130.2
Lithium.....	Li	3	6.940	Ytterbium.....	Yb	70	173.5
Lutecium.....	Lu	71	175.0	Yttrium.....	Y	39	88.92
Magnesium.....	Mg	12	24.32	Zinc.....	Zn	30	65.38
Manganese.....	Mn	25	54.93	Zirconium.....	Zr	40	91.22
Mercury.....	Hg	80	200.61				

¹ *Jour. Am. Chem. Soc.*, vol. 53, p. 1637, 1931.

TABLE II.—MISCELLANEOUS CONVERSION FACTORS

Lengths	
1 in. = 2.54 cm.	1 mm. = 0.03937 in.
1 ft. = 0.3048 m.	1 cm. = 0.3937 in.
1 yd. = 0.9144 m.	1 m. = 3.28 ft.
1 mi. = 1.60935 km.	1 km. = 0.62137 mi.
Volumes	
1 cu. in. = 16.3872 cu. cm.	1 cu. cm. = 0.061 cu. in.
1 cu. ft. = 0.02832 cu. m.	1 liter = 61.025 cu. in.
1 cu. yd. = 0.7646 cu. m.	1 cu. m. = 1.3079 cu. yd.
Capacities	
1 qt. = 0.94636 liter.	1 liter = 1.05668 qt.
1 gal. = 3.78543 liters.	1 liter = 0.26417 gal.
Masses	
1 oz. av. = 28.3495 grams	1 gram = 0.03527 oz.
1 lb. av. = 453.59 grams	1 kilo = 2.20462 lb.
1 gram = 15.43235 grains	
1 oz. = 437.5 grains	
1 lb. = 7,000.0 grains	
1 U. S. gallon = 58,333.0 grains	
1 Imp. gallon = 70,000.0 grains	
Heat Values	
1 B.t.u. = 252.0 cal.	
1 cal. = 0.003968 B.t.u.	
1 B.t.u. per pound = 0.5556 Cal. per gram	
1 cal. per gram = 1.8 B.t.u. per pound	
1 B.t.u. = 0.20 Cal.	
1 Cal. = 3.968 B.t.u.	
1 B.t.u. per pound = 0.5556 Cal. per kilo	
1 Cal. per kilo = 1.8 B.t.u. per pound	

TABLE III.—CONVERSION TABLES FOR TEMPERATURES
(Centigrade to Fahrenheit)

Temperature, degrees Centigrade	0	1	2	3	4	5	6	7	8	9
0	32.0	33.8	35.6	37.4	39.2	41.0	42.8	44.6	46.4	48.2
10	50.0	51.8	53.6	55.4	57.2	59.0	60.8	62.6	64.4	66.2
20	68.0	69.8	71.6	73.4	75.2	77.0	78.8	80.6	82.4	84.2
30	86.0	87.8	89.6	91.4	93.2	95.0	96.8	98.6	100.4	102.2
40	104.0	105.8	107.6	109.4	111.2	113.0	114.8	116.6	118.4	120.2
50	122.0	123.8	125.6	127.4	129.2	131.0	132.8	134.6	136.6	138.2
60	140.0	141.8	143.6	145.4	147.2	149.0	150.8	152.6	154.4	156.2
70	158.0	159.8	161.6	163.4	165.2	176.0	168.8	170.6	172.4	174.2
80	176.0	177.8	179.6	181.4	183.2	185.0	186.8	188.6	190.4	192.2
90	194.0	195.8	197.6	199.4	201.2	203.0	204.8	206.6	208.4	210.2
100	212.0	213.8	215.6	217.4	219.2	221.0	222.8	224.6	226.4	228.2

TABLE IV.—FACTORS FOR REDUCTION OF GAS VOLUME TO 60°F. AND 30 IN. OF MERCURY PRESSURE AND SATURATION WITH MOISTURE

		Barometer																				
		28.6	28.7	28.8	28.9	29.0	29.1	29.2	29.3	29.4	29.5	29.6	29.7	29.8	29.9	30.0	30.1	30.2	30.3	30.4	30.5	
107	0.816	0.820	0.823	0.826	0.829	0.832	0.835	0.838	0.841	0.844	0.847	0.851	0.854	0.857	0.860	0.864	0.867	0.870	0.874	0.878	0.881	0.884
106	0.820	0.823	0.826	0.829	0.832	0.835	0.838	0.841	0.844	0.847	0.851	0.854	0.857	0.860	0.863	0.867	0.870	0.874	0.878	0.881	0.884	0.887
105	0.823	0.827	0.830	0.833	0.836	0.839	0.842	0.845	0.848	0.851	0.855	0.858	0.861	0.864	0.867	0.871	0.874	0.878	0.881	0.884	0.887	0.891
104	0.827	0.830	0.833	0.836	0.839	0.842	0.845	0.848	0.851	0.854	0.858	0.861	0.864	0.867	0.871	0.874	0.878	0.881	0.884	0.887	0.891	0.894
103	0.830	0.834	0.837	0.840	0.843	0.847	0.849	0.852	0.855	0.858	0.862	0.865	0.868	0.871	0.874	0.878	0.881	0.884	0.887	0.891	0.894	0.897
102	0.834	0.837	0.840	0.843	0.847	0.850	0.853	0.856	0.859	0.862	0.865	0.868	0.871	0.874	0.878	0.881	0.884	0.887	0.891	0.894	0.897	0.900
101	0.837	0.840	0.843	0.846	0.850	0.853	0.856	0.859	0.862	0.865	0.868	0.872	0.875	0.878	0.881	0.884	0.887	0.891	0.894	0.897	0.900	0.903
100	0.840	0.843	0.846	0.849	0.853	0.856	0.859	0.862	0.865	0.868	0.872	0.875	0.878	0.881	0.884	0.887	0.891	0.894	0.897	0.900	0.903	0.906
99	0.844	0.847	0.850	0.853	0.857	0.860	0.863	0.866	0.869	0.872	0.876	0.879	0.882	0.885	0.889	0.892	0.895	0.898	0.902	0.905	0.908	0.911
98	0.847	0.850	0.853	0.856	0.860	0.863	0.866	0.869	0.872	0.875	0.879	0.882	0.885	0.888	0.892	0.895	0.898	0.902	0.905	0.908	0.911	0.914
97	0.850	0.853	0.856	0.859	0.863	0.866	0.870	0.873	0.876	0.879	0.882	0.885	0.888	0.891	0.894	0.897	0.901	0.904	0.908	0.911	0.914	0.917
96	0.854	0.857	0.860	0.863	0.867	0.870	0.873	0.876	0.879	0.882	0.885	0.888	0.891	0.894	0.897	0.901	0.904	0.908	0.911	0.914	0.917	0.921
95	0.857	0.860	0.863	0.866	0.870	0.873	0.876	0.879	0.882	0.885	0.888	0.891	0.894	0.897	0.901	0.904	0.908	0.911	0.914	0.917	0.921	0.924
94	0.860	0.863	0.866	0.869	0.873	0.876	0.879	0.882	0.885	0.888	0.891	0.894	0.897	0.901	0.904	0.907	0.911	0.914	0.918	0.921	0.924	0.928
93	0.863	0.866	0.869	0.872	0.876	0.879	0.883	0.886	0.889	0.891	0.895	0.898	0.901	0.904	0.907	0.910	0.914	0.918	0.921	0.924	0.928	0.932
92	0.866	0.869	0.872	0.875	0.879	0.882	0.885	0.889	0.892	0.894	0.898	0.902	0.904	0.907	0.910	0.914	0.917	0.921	0.924	0.928	0.931	0.934
91	0.869	0.872	0.875	0.879	0.882	0.885	0.889	0.892	0.895	0.898	0.901	0.905	0.908	0.911	0.914	0.917	0.921	0.924	0.928	0.931	0.934	0.937
90	0.872	0.875	0.878	0.881	0.885	0.888	0.892	0.895	0.898	0.901	0.905	0.908	0.911	0.914	0.917	0.920	0.924	0.927	0.931	0.934	0.937	0.940
89	0.875	0.878	0.882	0.885	0.889	0.892	0.895	0.898	0.901	0.904	0.907	0.910	0.914	0.917	0.920	0.923	0.926	0.929	0.932	0.934	0.937	0.940
88	0.878	0.881	0.885	0.888	0.892	0.895	0.898	0.901	0.904	0.907	0.910	0.913	0.916	0.920	0.923	0.926	0.929	0.932	0.936	0.939	0.943	0.946
87	0.881	0.884	0.888	0.891	0.895	0.898	0.901	0.904	0.907	0.910	0.913	0.916	0.920	0.923	0.926	0.929	0.933	0.937	0.940	0.943	0.946	0.949
86	0.884	0.887	0.890	0.894	0.898	0.901	0.904	0.907	0.910	0.913	0.916	0.919	0.923	0.926	0.929	0.932	0.936	0.939	0.942	0.945	0.949	0.952
85	0.887	0.890	0.893	0.896	0.900	0.903	0.906	0.909	0.912	0.915	0.918	0.921	0.924	0.928	0.931	0.935	0.938	0.942	0.945	0.949	0.952	0.955
84	0.889	0.893	0.896	0.899	0.903	0.906	0.909	0.912	0.915	0.919	0.922	0.925	0.928	0.932	0.935	0.939	0.942	0.946	0.949	0.952	0.955	0.958
83	0.892	0.895	0.899	0.902	0.906	0.909	0.912	0.915	0.918	0.921	0.924	0.927	0.931	0.934	0.937	0.941	0.945	0.948	0.951	0.954	0.957	0.960
82	0.895	0.898	0.901	0.905	0.908	0.911	0.914	0.918	0.921	0.924	0.927	0.930	0.934	0.937	0.940	0.944	0.948	0.951	0.954	0.957	0.960	0.963
81	0.898	0.901	0.905	0.908	0.911	0.914	0.917	0.921	0.924	0.927	0.930	0.934	0.937	0.940	0.944	0.948	0.951	0.954	0.957	0.960	0.963	0.966

Temperature degrees Fahrenheit

TABLE IV.—FACTORS FOR REDUCTION OF GAS VOLUME TO 60°F. AND 30 IN. OF MERCURY PRESSURE AND SATURATION WITH MOISTURE.—(Continued)

		Barometer																			
		28.6	28.7	28.8	28.9	29.0	29.1	29.2	29.3	29.4	29.5	29.6	29.7	29.8	29.9	30.0	30.1	30.2	30.3	30.4	30.5
80	0.901	0.904	0.907	0.910	0.914	0.917	0.920	0.923	0.926	0.929	0.933	0.937	0.940	0.943	0.946	0.950	0.954	0.958	0.962	0.966	0.969
79	0.906	0.907	0.910	0.914	0.917	0.920	0.923	0.926	0.930	0.933	0.936	0.939	0.942	0.946	0.949	0.952	0.956	0.959	0.962	0.966	0.969
78	0.906	0.909	0.913	0.916	0.919	0.923	0.926	0.930	0.933	0.936	0.939	0.942	0.946	0.949	0.952	0.956	0.959	0.962	0.966	0.969	0.972
77	0.909	0.912	0.915	0.919	0.922	0.925	0.928	0.931	0.935	0.938	0.942	0.945	0.948	0.951	0.955	0.958	0.962	0.965	0.968	0.972	0.975
76	0.911	0.915	0.918	0.921	0.925	0.928	0.931	0.935	0.938	0.941	0.944	0.948	0.951	0.954	0.958	0.961	0.964	0.968	0.971	0.975	0.978
75	0.914	0.917	0.921	0.924	0.928	0.931	0.934	0.937	0.940	0.943	0.947	0.950	0.954	0.957	0.960	0.963	0.967	0.971	0.974	0.978	0.981
74	0.917	0.920	0.924	0.927	0.930	0.933	0.937	0.940	0.943	0.947	0.950	0.953	0.957	0.960	0.963	0.966	0.970	0.973	0.977	0.980	0.983
73	0.920	0.923	0.926	0.930	0.933	0.936	0.940	0.943	0.946	0.949	0.953	0.956	0.960	0.963	0.966	0.969	0.972	0.976	0.980	0.983	0.986
72	0.922	0.925	0.929	0.932	0.935	0.939	0.942	0.945	0.949	0.952	0.955	0.959	0.962	0.965	0.968	0.972	0.975	0.979	0.982	0.986	0.989
71	0.925	0.928	0.931	0.935	0.938	0.941	0.945	0.948	0.951	0.954	0.958	0.961	0.965	0.968	0.971	0.975	0.978	0.981	0.985	0.989	0.992
70	0.927	0.931	0.934	0.937	0.941	0.944	0.947	0.950	0.954	0.957	0.960	0.964	0.967	0.970	0.974	0.977	0.980	0.984	0.988	0.991	0.994
69	0.930	0.933	0.937	0.940	0.944	0.947	0.950	0.953	0.957	0.960	0.963	0.967	0.970	0.973	0.977	0.980	0.983	0.987	0.990	0.994	0.997
68	0.932	0.936	0.939	0.942	0.946	0.949	0.952	0.955	0.959	0.962	0.965	0.968	0.972	0.975	0.979	0.982	0.985	0.988	0.992	0.995	0.998
67	0.935	0.938	0.942	0.945	0.949	0.952	0.955	0.959	0.962	0.965	0.968	0.971	0.974	0.978	0.981	0.985	0.988	0.992	0.995	0.998	1.002
66	0.938	0.941	0.944	0.948	0.951	0.954	0.958	0.961	0.964	0.968	0.971	0.974	0.978	0.981	0.985	0.988	0.992	0.995	0.998	1.001	1.005
65	0.941	0.944	0.947	0.950	0.954	0.957	0.960	0.963	0.967	0.970	0.973	0.977	0.980	0.984	0.987	0.991	0.994	0.997	1.001	1.005	1.008
64	0.943	0.946	0.949	0.953	0.956	0.959	0.963	0.966	0.969	0.973	0.976	0.980	0.983	0.986	0.990	0.994	0.997	1.001	1.004	1.008	1.011
63	0.945	0.949	0.952	0.955	0.959	0.962	0.965	0.969	0.972	0.975	0.979	0.982	0.985	0.989	0.993	0.996	1.000	1.003	1.006	1.010	1.013
62	0.947	0.951	0.954	0.958	0.961	0.964	0.968	0.971	0.975	0.978	0.981	0.985	0.988	0.991	0.995	0.999	1.002	1.005	1.008	1.011	1.015
61	0.950	0.954	0.957	0.961	0.964	0.967	0.971	0.974	0.977	0.981	0.984	0.987	0.991	0.994	0.998	1.001	1.004	1.007	1.010	1.014	1.017
60	0.952	0.956	0.959	0.963	0.966	0.969	0.973	0.976	0.980	0.983	0.986	0.990	0.993	0.997	1.000	1.004	1.007	1.010	1.014	1.017	1.020
59	0.955	0.959	0.962	0.966	0.969	0.972	0.976	0.979	0.983	0.986	0.989	0.992	0.995	0.999	1.003	1.006	1.010	1.013	1.016	1.019	1.023
58	0.957	0.961	0.964	0.968	0.971	0.975	0.978	0.981	0.985	0.988	0.992	0.995	0.998	1.002	1.005	1.009	1.012	1.016	1.019	1.023	1.026
57	0.960	0.963	0.967	0.970	0.974	0.977	0.980	0.984	0.988	0.991	0.994	0.997	1.001	1.004	1.007	1.011	1.014	1.018	1.021	1.025	1.028
56	0.962	0.966	0.969	0.973	0.976	0.979	0.982	0.986	0.990	0.993	0.996	1.000	1.003	1.007	1.010	1.014	1.017	1.021	1.024	1.028	1.031
55	0.965	0.968	0.972	0.975	0.979	0.982	0.985	0.989	0.993	0.996	0.999	1.002	1.006	1.009	1.013	1.016	1.020	1.023	1.027	1.030	1.033
54	0.967	0.970	0.974	0.977	0.981	0.984	0.988	0.991	0.995	0.998	1.001	1.005	1.008	1.012	1.015	1.019	1.022	1.026	1.029	1.033	1.036

Temperature degrees Fahrenheit

TABLE IV.—FACTORS FOR REDUCTION OF GAS VOLUME TO 60°F. AND 30 IN. OF MERCURY PRESSURE AND SATURATION WITH MOISTURE.—(Concluded)

		Barometer																			
		28.6	28.7	28.8	28.9	29.0	29.1	29.2	29.3	29.4	29.5	29.6	29.7	29.8	29.9	30.0	30.1	30.2	30.3	30.4	30.5
53	Temperature	0.969	0.973	0.976	0.980	0.983	0.986	0.990	0.993	0.997	1.000	1.004	1.007	1.011	1.014	1.018	1.021	1.025	1.028	1.031	1.035
52	Fahrenheit	0.971	0.975	0.978	0.982	0.985	0.989	0.992	0.996	0.999	1.003	1.006	1.010	1.013	1.017	1.020	1.024	0.027	0.030	0.033	0.037
51		0.974	0.977	0.981	0.984	0.988	0.991	0.995	0.998	1.002	1.005	1.009	1.012	1.016	1.020	1.023	1.027	1.030	1.033	1.037	1.040
50		0.976	0.980	0.983	0.987	0.990	0.994	0.997	1.001	1.004	1.008	1.011	0.115	0.118	0.122	0.126	0.129	0.133	0.136	0.140	0.143
49		0.979	0.982	0.986	0.989	0.993	0.996	1.000	1.003	1.007	1.011	1.014	1.018	1.021	1.025	1.028	1.032	1.035	1.039	1.042	1.045
48		0.981	0.985	0.988	0.992	0.995	0.999	1.002	1.006	1.009	1.013	1.017	1.020	1.024	1.027	1.031	1.034	1.038	1.041	1.045	1.048
47		0.984	0.987	0.991	0.994	0.998	1.001	1.005	1.008	1.012	1.015	1.019	1.022	1.026	1.029	1.033	1.036	1.040	1.043	1.047	1.050
46		0.986	0.990	0.993	0.997	1.000	1.004	1.007	1.011	1.014	1.018	1.021	1.025	1.028	1.032	1.035	1.039	1.042	1.046	1.049	1.053
45		0.989	0.992	0.996	0.999	1.003	1.006	1.010	1.013	1.017	1.020	1.024	1.027	1.031	1.034	1.038	1.041	1.045	1.048	1.052	1.056
44		0.991	0.994	0.998	1.001	1.005	1.008	1.012	1.015	1.019	1.022	1.026	1.029	1.033	1.036	1.040	1.043	1.047	1.050	1.054	1.058
43		0.993	0.997	1.001	1.004	1.008	1.011	1.015	1.018	1.022	1.025	1.029	1.032	1.036	1.039	1.043	1.046	1.050	1.053	1.057	1.060
42		0.995	0.999	1.003	1.006	1.010	1.013	1.017	1.020	1.024	1.027	1.031	1.034	1.038	1.041	1.045	1.048	1.052	1.055	1.059	1.063
41		0.998	1.001	1.005	1.009	1.012	1.016	1.019	1.023	1.026	1.030	1.034	1.037	1.041	1.044	1.048	1.051	1.055	1.058	1.062	1.065
40		1.000	1.004	1.007	1.011	1.014	1.018	1.021	1.025	1.028	1.032	1.036	1.039	1.043	1.046	1.050	1.053	1.057	1.060	1.064	1.068
39		1.002	1.006	1.010	1.013	1.017	1.020	1.024	1.028	1.031	1.035	1.038	1.042	1.045	1.049	1.052	1.056	1.059	1.063	1.066	1.070
38		1.005	1.009	1.012	1.016	1.020	1.023	1.027	1.030	1.034	1.037	1.041	1.044	1.048	1.051	1.055	1.058	1.062	1.065	1.069	1.073
37		1.007	1.011	1.015	1.018	1.022	1.025	1.029	1.032	1.036	1.039	1.043	1.046	1.050	1.053	1.057	1.060	1.064	1.068	1.071	1.075
36		1.009	1.013	1.017	1.020	1.024	1.027	1.031	1.035	1.038	1.042	1.045	1.049	1.052	1.056	1.059	1.063	1.066	1.070	1.074	1.078
35		1.012	1.015	1.019	1.022	1.026	1.030	1.033	1.037	1.041	1.044	1.048	1.051	1.055	1.058	1.062	1.065	1.069	1.073	1.077	1.081
34		1.014	1.018	1.022	1.025	1.029	1.032	1.036	1.040	1.043	1.047	1.050	1.054	1.057	1.061	1.064	1.068	1.072	1.075	1.079	1.083
33		1.016	1.020	1.024	1.027	1.031	1.034	1.038	1.042	1.046	1.049	1.053	1.056	1.060	1.063	1.067	1.070	1.074	1.078	1.082	1.086
32		1.019	1.023	1.027	1.030	1.034	1.037	1.041	1.044	1.048	1.051	1.055	1.058	1.062	1.065	1.069	1.073	1.077	1.081	1.085	1.089
31		1.021	1.025	1.029	1.032	1.036	1.039	1.043	1.047	1.050	1.054	1.057	1.061	1.064	1.068	1.072	1.075	1.079	1.083	1.087	1.091
30		1.023	1.027	1.031	1.034	1.038	1.042	1.045	1.049	1.053	1.056	1.060	1.063	1.067	1.071	1.074	1.078	1.082	1.086	1.090	1.094

TABLE V.—RELATIVE HUMIDITY
 (As determined from readings of wet and dry bulb thermometer.
 Calculated for barometric pressure of 29.0 in. of mercury)
 (All temperatures in Fahrenheit degrees)

Air temperature	Depression of wet bulb thermometer ($t - t'$)																								
	1	2	3	4	5	6	7	8	9	10	11	12	13	14	15	16	17	18	19	20	21	22	23	24	25
30	89	78	68	57	47	37	27	17	8																
35	91	82	73	64	55	46	37	29	20	12	4														
40	92	84	76	68	61	53	46	38	31	23	16	9	2												
45	93	86	79	71	65	58	52	45	39	33	26	20	14	8	2										
50	93	87	81	74	68	62	56	50	44	39	33	28	22	17	12	7	2								
55	94	88	82	76	71	65	60	55	49	44	39	34	29	25	20	15	11	6	2						
60	94	89	84	78	73	68	63	58	53	49	44	40	35	31	27	22	18	14	10	6	2				
65	95	90	85	80	75	70	66	62	57	53	48	44	40	36	32	28	25	21	17	13	10	7	3		
70	95	90	86	81	77	72	68	64	60	56	52	48	44	40	37	33	30	26	23	20	17	13	10	7	4
75	96	91	87	82	78	74	70	66	63	59	55	51	48	44	41	38	34	31	28	25	22	19	16	13	11
80	96	91	87	83	79	76	72	68	64	61	57	54	51	47	44	41	38	35	32	29	27	24	21	18	16
85	96	92	88	84	80	77	74	70	66	63	60	57	54	50	47	44	41	39	36	33	31	28	25	23	20
90	96	92	89	85	81	78	75	71	68	65	62	59	56	53	50	47	44	42	39	37	34	32	29	27	24
95	96	93	89	86	82	79	76	73	70	66	64	61	58	55	52	50	47	45	42	40	37	35	32	30	28
100	96	93	90	86	83	80	77	74	71	68	65	62	59	57	54	52	49	47	44	42	40	37	35	33	31

TABLE VI.—CORRECTIONS, IN BRITISH THERMAL UNITS, TO BE APPLIED TO OBSERVED HEATING VALUES IN CALCULATING TOTAL HEATING VALUES OF ILLUMINATING GAS

(About 600 B.t.u.)¹

(The tabular corrections are applicable when inlet water, air, gas, and products are all at approximately the same temperature, and when the calorimeter is operated at *normal rate* of gas consumption.)

Temperature of room, etc., degrees Fahrenheit	Relative humidity of air									
	10 per cent	20 per cent	30 per cent	40 per cent	50 per cent	60 per cent	70 per cent	80 per cent	90 per cent	100 per cent
40	+ 2	+ 2	+ 1	+ 1	+ 1	+ 1	0	0	0	- 1
45	+ 2	+ 2	+ 2	+ 1	+ 1	+ 1	0	0	0	- 1
50	+ 3	+ 3	+ 2	+ 2	+ 1	+ 1	0	0	0	- 1
55	+ 3	+ 3	+ 3	+ 2	+ 1	+ 1	+ 1	0	0	- 1
60	+ 4	+ 4	+ 3	+ 2	+ 2	+ 1	+ 1	0	0	- 1
65	+ 5	+ 4	+ 4	+ 3	+ 2	+ 2	+ 1	0	- 1	- 1
70	+ 6	+ 5	+ 4	+ 3	+ 3	+ 2	+ 1	0	- 1	- 2
75	+ 7	+ 6	+ 5	+ 4	+ 3	+ 2	+ 1	0	- 1	- 2
80	+ 8	+ 7	+ 6	+ 5	+ 4	+ 3	+ 1	0	- 1	- 2
85	+ 10	+ 9	+ 7	+ 6	+ 4	+ 3	+ 2	0	- 1	- 3
90	+ 12	+ 10	+ 9	+ 7	+ 5	+ 4	+ 2	0	- 2	- 3
95	+ 14	+ 12	+ 10	+ 8	+ 6	+ 4	+ 2	0	- 2	- 4

U. S. Bur. Standards, *Tech. Paper 36*.

TABLE VII.¹—EMERGENT STEM CORRECTIONS TO READING OF OUTLET-WATER THERMOMETERS FOR DIFFERENT IMMERSIONS OF THERMOMETERS IN CALORIMETER FOR DETERMINING HEATING VALUE OF GAS

(Table applicable when temperature of inlet water is approximately equal to room temperature)

	Temperature rise of water, degrees Fahrenheit	Temperature of room					
		50°	60°	70°	80°	90°	100°
Thermometer immersed to 30°F...	10	+0.02	+0.03	+0.04	+0.05	+0.05	+0.06
	15	+0.04	+0.05	+0.06	+0.07	+0.09	+0.10
	20	+0.06	+0.07	+0.09	+0.11	+0.13	+0.15
Thermometer immersed to 40°F...	10	+0.01	+0.02	+0.03	+0.03	+0.04	+0.05
	15	+0.03	+0.04	+0.05	+0.06	+0.08	+0.09
	20	+0.04	+0.05	+0.07	+0.09	+0.11	+0.12
Thermometer immersed to 50°F...	10	+0.01	+0.01	+0.02	+0.03	+0.04	+0.05
	15	+0.02	+0.03	+0.04	+0.05	+0.07	+0.08
	20	+0.02	+0.04	+0.06	+0.07	+0.09	+0.11
Thermometer immersed to 60°F...	10	+0.00	+0.01	+0.02	+0.02	+0.03	+0.04
	15	+0.00	+0.01	+0.03	+0.04	+0.05	+0.06
	20	+0.00	+0.02	+0.04	+0.05	+0.07	+0.09

This table is not applicable if the emergent portion of the stem includes an enlargement in the capillary.

Instead of using the above table, it will probably be somewhat more convenient to make out a stem-correction table for the particular outlet-water thermometer that is to be used with the calorimeter, the data for this separate stem-correction table being interpolated from the above table.

Suppose, for example, the outlet-water thermometer to be used was one that was immersed to the 30°F. mark on the scale, and a stem-correction table were wanted for an 18°F. rise in temperature, then from the above table we obtain the following stem-correction table:

STEM CORRECTION FOR OUTLET-WATER THERMOMETER NO.—

Table applicable when inlet water is approximately at room temperature, when thermometer is immersed to the 30°F. mark, and when the temperature rise is approximately 18°F.

Inlet-water temperature, degrees Fahrenheit	Stem correction, degree	Inlet-water temperature, degrees Fahrenheit	Stem correction, degree
50	0.05	80	0.09
60	0.06	90	0.11
70	0.08	100	0.13

¹ From U. S. Bur. Standards, Cir. 48.

TABLE VIII.—SOLUBILITIES APPLICABLE TO BOILER WATERS

(a) Solubility of gypsum

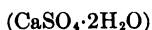

1 part dissolves in about 500 parts of water at 60°F.

1 part dissolves in about 1,200 parts of water at 250°F.

1 part dissolves in about 1,800 parts of water at 300°F.

1 part dissolves in about 3,800 parts of water at 325°F.

(b) Solubility of lime and hydrated lime

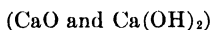

Amount required to saturate one U. S. gallon

78 grains CaO or 103.0 grains Ca(OH)_2 at 60°F.70 grains CaO or 92.5 grains Ca(OH)_2 at 86°F.58 grains CaO or 76.6 grains Ca(OH)_2 at 112°F.51 grains CaO or 67.4 grains Ca(OH)_2 at 140°F.33 grains CaO or 43.6 grains Ca(OH)_2 at 212°F.TABLE IX.¹—EQUIVALENT OF DEGREES BAUMÉ (AMERICAN STANDARD)
AND SPECIFIC GRAVITY AT 60°F. (HEAVIER THAN WATER)

Degrees Baumé	0	1	2	3	4	5	6	7	8	9
0	1.0000	1.0069	1.0140	1.0211	1.0284	1.0357	1.0432	1.0507	1.0584	1.0662
10	1.0741	1.0821	1.0902	1.0985	1.1069	1.1154	1.1240	1.1328	1.1417	1.1508
20	1.1600	1.1694	1.1789	1.1885	1.1983	1.2083	1.2185	1.2288	1.2393	1.2500
30	1.2609	1.2719	1.2832	1.2946	1.3063	1.3182	1.3303	1.3426	1.3551	1.3679
40	1.3810	1.3924	1.4078	1.4216	1.4356	1.4500	1.4646	1.4796	1.4948	1.5104
50	1.5263	1.5426	1.5591	1.5761	1.5934	1.6111	1.6292	1.6477	1.6667	1.6860
60	1.7059	1.7262	1.7470	1.7683	1.7901	1.8125	1.8354	1.8590	1.8831	1.9079

¹ For more complete table see VAN NOSTRAND'S "Chemical Annual."

TABLE X.¹—SPECIFIC GRAVITIES, POUNDS PER GALLON, AND GALLONS PER POUND AT 60°F., CORRESPONDING TO DEGREES A.P.I.

Degrees A.P.I.	Specific gravity at 60°/60°F.	Pounds per gallon at 60°F. ²	Gallons per pound at 60°F. ²	Degrees A.P.I.	Specific gravity at 60°/60°F.	Pounds per gallon at 60°F. ²	Gallons per pound at 60°F. ²
0	1.0760	8.962	0.1116	50	0.7796	6.490	0.1541
1	1.0679	8.895	0.1124	51	0.7753	6.455	0.1540
2	1.0599	8.828	0.1133	52	0.7711	6.420	0.1558
3	1.0520	8.762	0.1141	53	0.7669	6.385	0.1566
4	1.0443	8.698	0.1150	54	0.7628	6.350	0.1575
5	1.0366	8.634	0.1158	55	0.7587	6.316	0.1583
6	1.0291	8.571	0.1167	56	0.7547	6.283	0.1592
7	1.0217	8.509	0.1175	57	0.7507	6.249	0.1600
8	1.0143	8.448	0.1184	58	0.7467	6.216	0.1609
9	1.0071	8.388	0.1192	59	0.7428	6.184	0.1617
10	1.0000	8.328	0.1201	60	0.7389	6.151	0.1626
11	0.9930	8.270	0.1209	61	0.7351	6.119	0.1634
12	0.9861	8.212	0.1218	62	0.7313	6.087	0.1643
13	0.9792	8.155	0.1226	63	0.7275	6.056	0.1651
14	0.9725	8.099	0.1235	64	0.7238	6.025	0.1660
15	0.9659	8.044	0.1243	65	0.7201	5.994	0.1668
16	0.9593	7.989	0.1252	66	0.7165	5.964	0.1677
17	0.9529	7.935	0.1260	67	0.7128	5.934	0.1685
18	0.9465	7.882	0.1269	68	0.7093	5.904	0.1694
19	0.9402	7.830	0.1277	69	0.7057	5.874	0.1702
20	0.9340	7.778	0.1286	70	0.7022	5.845	0.1711
21	0.9279	7.727	0.1294	71	0.6988	5.817	0.1719
22	0.9218	7.676	0.1303	72	0.6953	5.788	0.1728
23	0.9159	7.627	0.1311	73	0.6919	5.759	0.1736
24	0.9100	7.578	0.1320	74	0.6886	5.731	0.1745
25	0.9042	7.529	0.1328	75	0.6852	5.703	0.1753
26	0.8984	7.481	0.1337	76	0.6819	5.676	0.1762
27	0.8927	7.434	0.1345	77	0.6787	5.649	0.1770
28	0.8871	7.387	0.1354	78	0.6754	5.622	0.1779
29	0.8816	7.341	0.1362	79	0.6722	5.595	0.1787
30	0.8762	7.296	0.1371	80	0.6690	5.568	0.1796
31	0.8708	7.251	0.1379	81	0.6659	5.542	0.1804
32	0.8654	7.206	0.1388	82	0.6628	5.516	0.1813
33	0.8602	7.163	0.1396	83	0.6597	5.491	0.1821
34	0.8550	7.119	0.1405	84	0.6566	5.465	0.1830
35	0.8498	7.076	0.1413	85	0.6536	5.440	0.1838
36	0.8448	7.034	0.1422	86	0.6506	5.415	0.1847
37	0.8398	6.993	0.1430	87	0.6476	5.390	0.1855
38	0.8348	6.951	0.1439	88	0.6446	5.365	0.1864
39	0.8299	6.910	0.1447	89	0.6417	5.341	0.1872
40	0.8251	6.870	0.1456	90	0.6388	5.316	0.1881
41	0.8203	6.830	0.1464	91	0.6360	5.293	0.1889
42	0.8155	6.790	0.1473	92	0.6331	5.269	0.1898
43	0.8109	6.752	0.1481	93	0.6303	5.246	0.1906
44	0.8063	6.713	0.1490	94	0.6275	5.222	0.1915
45	0.8017	6.675	0.1498	95	0.6247	5.199	0.1924
46	0.7972	6.637	0.1507	96	0.6220	5.176	0.1932
47	0.7927	6.600	0.1515	97	0.6193	5.154	0.1940
48	0.7883	6.563	0.1524	98	0.6166	5.131	0.1949
49	0.7839	6.526	0.1532	99	0.6139	5.109	0.1957
				100	0.6112	5.086	0.1966

¹ From Am. Soc. Testing Materials, Method D 289-30T, "Tentative Standards," 1930. This table is primarily an abridgment of Table V of the "National Standard Petroleum Oil Tables" as published in the U. S. Bureau of Standards, *Circular 154*, which contains similar data for each 0.1° A.P.I. from 10 to 100° A.P.I., inclusive. The data for gravities from 0 to 9° A.P.I., inclusive, have been added in order to extend the use of the A.P.I. gravity scale to petroleum oils having a specific gravity slightly greater than unity.

² The data in this column are based upon apparent weights in air, the weight of 1 gal. of water at 60°F. in air being assumed to be 8.32828 lb. Consequently, a correction for the buoyancy of air is required in computing these figures from the specific gravities in the second column.

TABLE XI.—SHOWING AMERICAN PETROLEUM INSTITUTE GRAVITY
CORRECTIONS FOR TEMPERATURE ABOVE 60°F.¹

(Compiled from U. S. Bureau of Standards, *Circular 154*)

(This table gives the corrections to be *subtracted* from the observed degrees A.P.I. of lubricating oils, etc., to obtain the true degrees A.P.I. at 60°F.)

Observed temperature, °F.	Observed degrees A.P.I.										
	16	18	20	22	24	26	28	30	32	34	36
	Subtract from observed degrees A.P.I. to give true degrees A.P.I. at 60°F.										
60	0.0	0.0	0.0	0.0	0.0	0.0	0.0	0.0	0.0	0.0	0.0
62	0.1	0.1	0.1	0.1	0.1	0.1	0.1	0.1	0.1	0.1	0.1
64	0.2	0.2	0.2	0.2	0.2	0.2	0.2	0.3	0.3	0.3	0.3
66	0.3	0.3	0.3	0.3	0.4	0.4	0.4	0.4	0.4	0.4	0.4
68	0.4	0.4	0.5	0.5	0.5	0.5	0.5	0.5	0.5	0.6	0.6
70	0.5	0.6	0.6	0.6	0.6	0.6	0.6	0.7	0.7	0.7	0.7
72	0.6	0.7	0.7	0.7	0.7	0.8	0.8	0.8	0.8	0.9	0.9
74	0.8	0.8	0.8	0.8	0.9	0.9	0.9	0.9	1.0	1.0	1.1
76	0.9	0.9	0.9	0.9	1.0	1.0	1.0	1.1	1.1	1.1	1.2
78	1.0	1.0	1.0	1.1	1.1	1.1	1.2	1.2	1.2	1.3	1.3
80	1.1	1.1	1.1	1.2	1.2	1.2	1.3	1.3	1.4	1.4	1.4
82	1.2	1.2	1.3	1.3	1.3	1.4	1.4	1.5	1.5	1.5	1.6
84	1.3	1.3	1.4	1.4	1.4	1.5	1.5	1.6	1.6	1.7	1.7
86	1.4	1.4	1.5	1.5	1.6	1.6	1.7	1.7	1.8	1.8	1.9
88	1.5	1.5	1.6	1.6	1.7	1.7	1.8	1.8	1.9	2.0	2.0
90	1.6	1.6	1.7	1.7	1.8	1.8	1.9	2.0	2.0	2.1	2.2
92	1.7	1.7	1.8	1.9	1.9	2.0	2.0	2.1	2.1	2.2	2.3
94	1.8	1.8	2.0	2.0	2.0	2.1	2.1	2.2	2.3	2.4	2.4
96	1.9	2.0	2.1	2.1	2.1	2.2	2.2	2.3	2.4	2.5	2.5
98	2.0	2.1	2.2	2.2	2.3	2.3	2.4	2.5	2.5	2.6	2.7
100	2.1	2.2	2.2	2.3	2.4	2.4	2.5	2.6	2.7	2.7	2.8
105	2.4	2.4	2.5	2.6	2.7	2.7	2.8	2.9	3.0	3.1	3.2
110	2.6	2.7	2.8	2.8	2.9	3.0	3.1	3.2	3.3	3.4	3.5
115	2.9	3.0	3.0	3.1	3.2	3.3	3.4	3.5	3.6	3.7	3.9
120	3.1	3.2	3.3	3.4	3.5	3.6	3.7	3.8	3.9	4.0	4.2

NOTE.—The corrections for temperatures *below* 60°F. are in the same proportion for lubricating oils as shown for temperatures *above* 60°F., but in this case the correction is to be *added*.

¹ From LOCKHART, "American Lubricants": The Chemical Publishing Company, Easton, Pa., 1927.

TABLE XII.—TABLE FOR CALCULATING THE SPECIFIC GRAVITY OF OILS AT 15.5°C.¹(Example: $A = \text{sp. gr. at } 20^\circ$ $A \times 1.00319 = \text{sp. gr. at } 15.5^\circ\text{C.}$)

Temperature, degrees Centigrade	Factor	Temperature, degrees Centigrade	Factor	Temperature, degrees Centigrade	Factor	Temperature, degrees Centigrade	Factor
10	0.99612	14	0.99894	18	1.00177	22	1.00462
11	0.99683	15	0.99965	19	1.00248	23	1.00534
12	0.99782	16	1.00035	20	1.00319	24	1.00605
13	0.99823	17	1.00106	21	1.00391	25	1.00677

¹ WRIGHT, C. H., *Jour. Soc. Chem. Ind.*, vol. 26, 513.

TABLE XIII.—MAUMENÉ TEST, SHOWING THE RISE IN TEMPERATURE OF COMMON OILS

From "Stillman's Engineering Chemistry," 4th edition

Name of observer

	Maumené	Schaedler	Archbutt	Allen	Stillman
	Degrees Centigrade	Degrees Centigrade	Degrees Centigrade	Degrees Centigrade	Degrees Centigrade
Lard oil	40	41	39.5
Tallow oil.....	41-43	39
Neat's foot oil.....	45	50	43	40
Oleo oil.....	37½	38½	37
Elain oil.....	38
Sperm oil.....	51	45-47	48
Whale oil.....	92	91	92
Menhaden oil.....	123-128	126	128
Dog-fish oil.....	80
Cod liver oil.....	102-103	103	113	110
Crude cotton seed oil.....	69.5	70	67-69	74
Rape oil.....	58	60
Castor oil.....	47	48	46	65	45
Olive oil.....	42	43	41-45	41-43	42
Rosin oil.....	28	18-22	10
Mineral lubricating oil..	3-4	3
Earth nut.....	67	67	47-80
Sea elephant.....	65
Corn oil.....	85

TABLE XIV.—PHYSICAL FACTORS FOR THE MORE COMMON OILS
Average values

Oils	Specific gravity	Degrees Baumé	Pounds per gallon	Maumené number	Iodine number	Saponification number
Castor.....	0.9640	15.2	8.03	46.5	86.0	181.5
Cocoanut.....	0.9115	23.6	7.59	21.0	10.0	257.0
Cod liver.....	0.9245	21.4	7.70	107.5	152.0	185.5
Corn (maize).....	0.9232	21.6	7.69	80.0	121.0	190.5
Cotton seed.....	0.9235	21.6	7.69	66.0	110.5	193.0
Hemp seed.....	0.9267	21.1	7.72	97.0	154.0	192.5
Lard.....	0.9160	22.8	7.63	43.5	72.5	196.5
Linseed.....	0.9345	19.8	7.78	115.0	186.0	192.5
Menhaden.....	0.9300	20.5	7.75	126.0	156.0	191.0
Neat's foot.....	0.9153	23.0	7.62	53.0	69.5	194.5
Olive.....	0.9160	22.8	7.63	43.0	79.0	192.5
Palm.....	0.9340	19.9	7.78	54.0	200.5
Peanut.....	0.9165	22.7	7.63	56.0	94.0	191.5
Rapeseed (Colza).....	0.9150	23.0	7.62	58.5	98.5	173.0
Sesame.....	0.9227	21.7	7.69	65.0	108.5	190.5
Soy bean.....	0.9265	21.1	7.72	60.0	130.0	195.0
Sperm.....	0.8808	29.3	7.34	85.0	85.5	135.0
Sunflower.....	0.9249	21.4	7.70	67.5	127.0	191.0
Tung.....	0.9395	19.0	7.83	157.5	193.5
Whale.....	0.9240	21.5	7.69	88.0	119.0	191.0
Water.....	1.0000	10.0	8.33			
Alcohol (95 per cent).....	0.80854	43.15	6.735			

NOTE.—Specific gravity, Baumé, gravity and pounds per gallon determined at 60°F.

TABLE XV.—VISCOSITY DATA AT 100°F. OF SERIES H AND L OILS FOR VISCOSITIES AT 210°F.¹

Visc. at 210°	Visc. at 100° series H	Visc. at 100° series L	Visc. difference L-H = D	Visc. at 210°F.	Visc. at 100°F. series H	Visc. at 100°F. series L	Visc. difference L-H = D	Visc. at 210°F.	Visc. at 100°F. series H	Visc. at 100°F. series L	Visc. difference L-H = D
40	93	107	14								
41	109	137	28	81	810	1,674	864	121	1,643	3,902	2,259
42	124	167	43	82	829	1,721	892	122	1,665	3,966	2,301
43	140	197	57	83	849	1,769	920	123	1,688	4,031	2,343
44	157	228	71	84	868	1,817	949	124	1,710	4,097	2,387
45	173	261	88	85	888	1,865	977	125	1,733	4,163	2,430
46	189	291	102	86	907	1,914	1,007	126	1,756	4,229	2,473
47	205	325	120	87	927	1,964	1,037	127	1,779	4,296	2,517
48	222	356	134	88	947	2,014	1,067	128	1,802	4,363	2,561
49	238	389	151	89	966	2,064	1,098	129	1,825	4,430	2,605
50	255	422	167	90	986	2,115	1,129	130	1,848	4,498	2,650
51	272	456	184	91	1,006	2,166	1,160	131	1,871	4,567	2,696
52	288	491	203	92	1,026	2,217	1,191	132	1,894	4,636	2,742
53	305	525	220	93	1,046	2,270	1,224	133	1,918	4,705	2,787
54	322	561	239	94	1,066	2,322	1,256	134	1,941	4,775	2,834
55	339	596	259	95	1,087	2,375	1,289	135	1,965	4,845	2,880
56	356	632	276	96	1,107	2,428	1,321	136	1,988	4,915	2,927
57	374	669	295	97	1,128	2,481	1,353	137	2,012	4,986	2,974
58	391	706	315	98	1,148	2,536	1,388	138	2,036	5,058	3,022
59	408	743	335	99	1,168	2,591	1,423	139	2,060	5,130	3,070
60	426	781	355	100	1,189	2,646	1,457	140	2,084	5,202	3,118
61	443	819	376	101	1,210	2,701	1,491	141	2,108	5,275	3,167
62	461	857	396	102	1,231	2,757	1,526	142	2,132	5,348	3,216
63	478	897	419	103	1,252	2,814	1,562	143	2,156	5,422	3,266
64	496	936	440	104	1,273	2,870	1,597	144	2,180	5,496	3,316
65	514	976	462	105	1,294	2,928	1,634	145	2,205	5,570	3,365
66	532	1,016	484	106	1,315	2,985	1,670	146	2,229	5,645	3,416
67	550	1,057	507	107	1,337	3,043	1,706	147	2,254	5,721	3,467
68	568	1,098	530	108	1,358	3,102	1,744	148	2,278	5,796	3,518
69	586	1,140	554	109	1,379	3,161	1,782	149	2,303	5,873	3,570
70	604	1,182	578	110	1,401	3,220	1,819	150	2,328	5,949	3,621
71	623	1,225	602	111	1,422	3,280	1,858	151	2,353	6,026	3,673
72	641	1,268	627	112	1,444	3,340	1,896	152	2,378	6,104	3,726
73	660	1,311	651	113	1,466	3,400	1,934	153	2,403	6,182	3,779
74	678	1,355	677	114	1,488	3,462	1,974	154	2,428	6,260	3,832
75	697	1,399	702	115	1,510	3,524	2,014	155	2,453	6,339	3,886
76	716	1,444	728	116	1,532	3,585	2,053	156	2,478	6,418	3,940
77	734	1,489	755	117	1,554	3,648	2,094	157	2,503	6,498	3,995
78	753	1,534	781	118	1,576	3,711	2,135	158	2,529	6,578	4,049
79	772	1,580	808	119	1,598	3,774	2,176	159	2,554	6,659	4,105
80	791	1,627	836	120	1,620	3,838	2,218	160	2,580	6,740	4,160

¹ From DEAN and DAVIS, *Chem. Met. Eng.*, vol. 36, p. 618, 1929.

INDEX

A

- Absorption of oxygen by coal, 61-68, 122-131
- Acceptance limits, contracts, 110
- "Air-dry" conditions, defined, 209
- Air sanitation, 118-120
- Alcohol, 161
- Alkali and acids in grease, 346
- Analysis of coals, 47
 - ash, 213
 - carbonate, 54, 214, 274
 - fixed carbon, by difference, 215
 - moisture, 208-212
 - proximate, 208-217
 - sulfur, 256-267
 - ultimate, 268-265
 - volatile matter, 214
- Anthracite, 59
 - structure of, 39
- Anthraxylon, 39, 42
- "As-received" condition, defined, 209
- Ash in coal, 49, 55, 95, 96, 105, 106, 114
 - corrected ash, 49, 54
 - correction for carbonates, 54, 213
 - determination of, 213
 - distribution of, 99
 - effect of storage on, 78
 - effect of, on value of fuel, 106
 - fusibility of, 91, 107
 - inherent, 97
 - source of, 97
- Ash content of grease, 345
- Atmospheric pollution, 94, 118
- Atomic weights, 349
- Attritus, 39, 42

B

- Berthier test, 221
- Bituminic portion of coal, 121
 - effect of oxygen on, 122, 129
 - relation of, to coking property, 123
- Bituminous coal, 59
 - structure of, 37
- Boiler tests on weathered coal, 79
- Boiler water analysis, 162, 310-328
 - alkali metals, 322
 - calcium sulfate, 315
 - chlorides, 321
 - boiler concentrates, 323
 - free carbon dioxide, 316
 - magnesium, 318
 - negative hardness, 319
 - permanent hardness, 318
 - phosphates, 325
 - sulfates, 320
 - temporary hardness, 317
 - total alkalinity, 317
 - total hardness, 319
 - treated water, 323
- Boiler waters, 162-176
 - carbon dioxide in, 164, 171, 317
 - chemical treatment of, 169
 - classification of, 165
 - coagulants for, 174
 - corrosion caused by, 167
 - effect of scale from, 167
 - foaming of, 168
 - industrial methods of softening, 174
 - mineral constituents in, 162-165
 - zeolite treatment of, 175
- Bone coal, 97
- Briquets, 142
- British thermal unit, defined, 218

Bureau of Mines, 25
 Butane gas, 151
 Buyer and seller, 104

C

- Calcium chloride, standard solution, 313
 Calcium sulfate in boiler waters, 315
 Calculations, in coal analysis, 215
 in fuel-gas analysis, 286
 Calorie, defined, 218
 Calorific determinations, 218-255
 by calculation, 220, 291
 definitions, 218
 on gas, 293
 on gasoline and volatile distillates, 233
 by oxygen bomb calorimeter, 223
 by peroxide calorimeter, 242
 on petroleum oils and residues, 234
 Calorific values, as basis of classification of coal, 55
 of coal, 20, 24, 46, 48, 64, 105, 114
 corrections for inert material in coal, 50
 corrections to, 50, 59
 effect of oxidation on, 64
 of fuel gas, 146, 291
 of liquid fuels, 161
 relation of, to oxygen content of coal, 48
 of wood, 24
 Calorimeters, 26, 33
 Atwater, 31
 gas, 293-299
 Hempel, 293
 Junkers, 293
 Lewis Thompson, 221
 Mahler, 32, 222
 Marcus Bull, 23, 30
 oxygen bomb, 32, 218, 241
 Parr adiabatic, 235
 Parr oxygen bomb, 32, 222-241
 Rumford, 28
 sodium peroxide, 32, 242-255
 Cannel coal, 42, 59
 Carbon, determination of total, 269
 Carbon dioxide, in boiler waters, 164, 171, 316
 detection tube, 69
 evolved from coal during oxygen absorption, 63-66
 in flue gases, 304
 in fuel gas, 281
 initial appearance of, from coal, 72-74
 liberated from fresh and oxidized coal, 125
 weight of carbon in, 272
 Carbon monoxide, determination of, in fuel gas, 282
 in flue gases, 304
 Carbonate in coal, correction for, 54
 determination of, 274
 modification in ashing method for, 54
 Carbonates in water, 164, 175, 177
 Carbonization of coal, 46, 121-138
 classification of methods for, 133
 effect of temperature on, 136
 Parr process for, 137
 preheating of coal for, 138
 theory of, 131
 Chlorides, in coal, 95
 in waters, 321
 Clarain, 41
 Classification of coal, 42-60
 bibliography for, 43
 calorific value and volatile matter as basis of, 48, 55-57
 Frazer's, 43
 Parr's, 44
 Seyler's, 59
 Clinker formation, 89
 Cloud test, 190, 334
 Coagulants, 174
 Coal, 2
 available hydrogen in, 45
 carbonization of, 46, 121, 138
 classification of, 42-60
 combustion of, 86-94
 constitution of, 34-41, 121
 discovery of, in America, 6-9

- Coal, distribution and production
of, 6-19
effect of temperature on constituents of, 136
fundamental properties of, related to carbonization, 121-132
ignition temperature of, 72-74
Illinois, 13, 47, 54, 63
impurities in, 95-102
inert matter in, 48, 49, 53
oxidation of, 63, 71-74, 122-130
oxygen absorption by, 61-68
oxygen required in combustion of, 87
production of, in United States, 11, 13, 16
proximate analysis of, 208-217
pure, 48
reserves of world, 11, 12
sampling of, 105, 194-207
slacking of, 75
solvents for, 121
storage of, 67, 75-85
structure of, 37-41
types 11, 42, 47, 48, 57
ultimate analysis of, 268-275
uses of, 13, 19
volatile matter in, 107
- Coal cleaning, 114
- Coal contracts, 103-115
acceptance limits, 110
buyer and seller, 104
comparison of coal bids, 108
double ash-penalty in, 106
price of coal, 111
size of coal, specifications, 107
specifications in, 105, 194, 207
- Coal industry, early history of, in United States, 9, 23
- Coalification, 45
- Coke, 123, 139-142
effect of coking temperature on reactivity of, 142
reactivity of, 139
structure of, 61
- Coking property, determination of, 122
relation to state of oxidation, 123
- Color of oils, 343
- Combustion of coal, 86-94
oxygen required for, 87
wetting of coal before, 91
- Comparison of coal bids, 108
- Complete gasification of coal, 150
- Conradson test, 189, 333
- Consistency of grease, 345
- Constitution of coal, 34-41, 121
- Conversion factors, 350, 351
- Corrections to calorific value, 50, 59
- Corrosion sources in boiler waters, 167
- Critical oxidation temperature, 72-74
- D
- Decomposition stages of vegetal material, 46
- Deterioration of oils, 191
- Disintegration of coal during storage, 79
- Distribution of impurities in coal, 99
- Double ash-penalty, 106
- Durain, 41
- E
- Efficiency of combustion, 304
- Embrittlement of boiler plate, 177-184
A.S.M.E. Boiler Code for, 183
cause of, 178
characteristics of cracks in, 181
location of cracks in, 182
prevention of, 180, 182
- Emulsification of oils, 190, 336
- Excess air used in combustion, 304
- F
- Fatty oils, in grease, 346
- Fillers in grease, 346

Fixed carbon, 24
 determination of, by difference, 215

Flash and fire test, 189, 331

Float-and-sink samples, calorific value of, 52
 sulfur and ash values of, 101

Flue gas analysis, 301-309
 apparatus for, 302
 calculation of heat losses from, 304
 reagents for, 302
 sampling, 301

Foaming of boiler waters, 168

Fuel briquets, 142

Fuel gas, 145, 152
 calorific values of, 146, 291
 carbureted water gas, 148
 coal gas and coke oven gas, 149
 composition of, 146
 natural gas, 145, 150
 producer gas, 147
 refinery gas, 151
 specific gravity of, 300
 water gas, 145, 148, 150

Fuel gas analysis, 276-300
 apparatus, 278
 procedure, 280-286

Fuel ratio, 24

Fuel research, 20-25

Fuels, production of, 4
 relative values of, 4
 types of, 3

Fusain, 39, 76

G

Gases from distillation of coal, 125

Gravity, 2

Greases, 185, 343

Gross and net heat values, 235, 299

Gypsum, in coal, 97
 solubility of, 165, 358

H

Heat and energy, 2

Heat losses in flue gases, 306

Heating of coal in storage, 32

Heating value (*see* Calorific value).

Humidity, 355
 corrections of calorific values for, 298, 356

Hydrocarbons, in combustion of coal, 86
 in fuel gas, 146, 283

Hydrogen, available in coal, 45
 determination of, by computation, 268, 274
 in fuel gas, 282

Hydrogen sulfide, determination in fuel gas, 288

I

Ignition point, of coal, 69-74
 of gases, 88

Illinois coal, 13, 47, 54, 63
 coking tests on, 122
 effect of temperature on constituents of, 136
 forms of sulfur in, 98
 ignition temperatures of, 74
 impurities in, 99
 storage of, 78

Illuminants in fuel gas, 149, 281

Impurities in coal, 49, 95-102
 distribution of, 99

Inert matter in coal, 48, 49, 53

L

Lignite, analysis, 47
 distribution of, 12

Lignitic portion of coal, 121
 effect of oxygen on, 122, 129
 relation of, to coking property, 123

Ligno-cellulose, 45

Lime, solubility of, 172, 358
 for water treatment, 171

Liquid fuels, calorific values of, 161

Lubricants, 185-193, 329-348
 cloud test, 190, 334
 color of, 343
 Conradson test. 189. 333

Lubricants, deterioration of, 191
 emulsification of, 190, 336
 flash and fire test on, 189, 333
 free acids in, 191, 338
 grease examination, 343
 Maumené test, 191, 340
 pour test, 190, 334
 saponification of, 191, 339
 specific gravity of, 191, 340
 testing of, 187, 329-348
 viscosity of, 187, 329

M

Magnesium in waters, 172, 317
 Maumené test, 191, 340, 361
 Melting point of grease, 344
 Metamorphism in coal, 45
 Moisture in coal, 47, 49, 67, 95, 96,
 107, 114, 204, 208-212
 determination of, 211
 effect on slacking, 76
 evolved during oxygen absorption,
 63-66
 interpretation of values for, 212
 loss of, on air-drying, 210
 nomenclature, 208
 Molar solution, defined, 310
 Molecular action, as source of power,
 2
 Mother of coal, 39
 Motion, source of, 1

N

Natural gas, 145, 150
 Negative hardness, 319
 Nitrogen, in coal, 268
 in flue gases, 304
 in fuel gas, 146, 285
 Normal solution, defined, 310

O

Oils (*see* Lubricants).
 Orsat apparatus, 278, 302

Oxidation, of coal, 63, 71-74, 122-131
 of pyrite and marcasite, 81
 Oxygen, in coal, 44
 determination of, by difference,
 275
 relation of, to calorific value, 48
 determination in fuel gas, 282
 in flue gases, 304
 required during combustion, 87
 Oxygen absorption by coal, 61-68,
 122-131
 effect of, on lignitic and bituminic
 portion, 122-127
 on softening properties of coal,
 128
 experimental methods in studying,
 61
 relation of, to storage of coal, 67,
 75-79

P

Peat, 59
 Permanent hardness, 170, 318
 Petroleum, 157-160
 history of, 157
 production of, 159
 refining of, 160
 Phenol extraction of coal, 121
 Phosphates in boiler waters, 325
 Phosphorus in coal, 98
 Pocahontas coal, analysis, 47
 ignition temperature, 72
 Power, 1-5
 Price of coal, 111
 Processed fuels, 139-144
 Proximate analysis of coal, 208-217
 Public utilities, fuel consumption by,
 16, 18
 Pulverized fuel, 93
 sampling, 206
 Pure coal, 48
 Pyrite, 49, 89, 95, 97
 rate of oxidation of, 81

R

Railroads, fuel consumption by, 16
 17

S

St. Louis coal tests, 25
 Sampling of coal, 105, 194-207
 amount required, 195
 car lots, 201
 care in, 195
 commercial samples, 194
 composite samples, 202
 face samples, 194
 grinding, 197, 203
 hand samples, 194
 laboratory sample, 210
 material taken, 195
 mechanical, 203
 mixing and subdividing, 198
 moisture controlled in, 204
 riffing, 200
 pulverized fuel, 206
 sizes, 196
 Saponification test, 191, 339
 Size of coal, specifications, 107
 Slacking of coals, 75
 Slagging of boiler tubes, 91
 Smoke, 86-89, 116-120
 Soap, in grease, 346
 Soap solution, standard, 314
 Soda ash, for water treatment, 173
 Sodium carbonate, standard solution, 311
 in water, 165, 175, 177, 317
 decomposition in boiler, 178
 source, 179
 Softening temperature of coal, 127
 Source of power, 2
 Specific gravity, of fuel gas, 300
 of oils, 191, 340
 conversion tables, 358-361
 Specifications in coal contracts, 105
 Spontaneous combustion, 61, 72, 75, 81-85
 Steam emulsion test, 336
 Stokers, 88, 90
 Storage of coal, 67, 73, 75-85
 effect of moisture content on, 68
 effect of size on, 68, 75
 heating of coal in storage, 82

Sulfates in waters, 320
 Sulfur in coal, 49, 50, 55, 59, 95, 97, 107
 distribution of, 99
 effect of, on spontaneous combustion, 81
 forms of, 97
 organic, 98, 101
 Sulfur compounds in flue gases, 94
 Sulfur determinations, 256-267
 in bomb washings, 232, 241, 256
 Eschka method, 257
 in fuel gas, 288
 in heavy petroleum oils, 264
 in motor fuels by lamp method, 265
 from peroxide fusion, 258
 turbidimetric, 260
 Sulfuric acid, standard solution, 7

T

Temporary hardness, 170, 317
 Therm, defined, 149
 Thermometers, stem correct
 Turbidimeter, 260

U

Ultimate analysis, s'
 268-275
 Unit B.t.u., 50, 114
 Unit coal, 48, 51
 accuracy of calorific values
 comparison of 3, 59
 definitions,
 effect of st
 float-and-
 formula 1
 use of, 5-57

Viscosity of oils, 10, 9, 363
 S.A.E. number for, 188
 viscosity index, 188

