

# Birla Central Library

PILANI (Jaipur State)

Engg. College Branch

Class No 621.384/32

Book No C 384 E

Accession No 31683







**ELECTRONIC CONTROL  
OF  
RESISTANCE WELDING**

*The quality of the materials used in the manufacture  
of this book is governed by continued postwar shortages,*



**ELECTRONIC CONTROL**  
**OF**  
**RESISTANCE WELDING**

by **GEORGE M. CHUTE**  
Application Engineer,  
General Electric Company, at Detroit

First Edition  
SEVENTH IMPRESSION

**New York McGRAW-HILL BOOK COMPANY, INC. London**

**1943**

ELECTRONIC CONTROL OF RESISTANCE WELDING

COPYRIGHT, 1943, BY THE  
MCGRAW-HILL BOOK COMPANY, INC.

PRINTED IN THE UNITED STATES OF AMERICA

*All rights reserved. This book, or  
parts thereof, may not be reproduced  
in any form without permission of  
the publishers.*

## PREFACE

Spot welders are now being used for joining together an increasing variety of metals, and they have a vital part in the production of war materials. To control such resistance welders, electron tubes are often used. The men who service or work with tube-operated equipments want to know how and why the tubes work in the circuits, so that they can more intelligently keep the welders in production.

The subject of tube-operated welder controls has been taught by the author and his coworkers in evening classes attended by hundreds of men who work in vital war industries in the Detroit area. From these men the author has learned the information they need. The same instruction is presented here, in simple style, for those who have little knowledge of electricity. This book is written for the men who, perhaps without technical training, are given the responsibility of keeping resistance welding equipment in service.

The simple explanation of tubes and circuits may also help those who need a basic introduction to electronics without going into technical detail.

Much of the information has appeared in the instructions furnished with various control equipments. Much is taken from a collection of papers recently prepared by a group of General Electric engineers. To these have been added the basic facts needed for a complete understanding of the control equipments. The process of resistance welding itself is only briefly mentioned.

The author wishes to acknowledge the assistance of the Electronic Control Division of the General Electric Company, especially that of G. W. Garman, H. L. Palmer, and their coworkers. Photographs have been supplied by General Electric.

GEORGE M. CHUTE.

Detroit,  
May, 1943.



# CONTENTS

	PAGE
PREFACE . . . . .	v
SYMBOLS OF DEVICES . . . . .	xi

## Part I

### IGNITRON CONTACTORS, TUBES AND WELD TIMERS

#### CHAPTER

1. THE RESISTANCE WELDER IN YOUR PLANT. . . . .	1
Spot, gun and ram welders—Welder circuit—Magnetic contactor and ignitron contactor.	
2. ALTERNATING CURRENT FOR THE WELDER . . . . .	6
Short time—The cycle—The a-c curve—One-way current—Volts—Amperes—Resistance—Fuses—Heat to make a weld—Large current—Kva.	
3. THE IGNITRON CONTACTOR. . . . .	14
Tube anode, cathode, igniter—Ignitron construction—Ignitron-contactor circuit—Protecting igniters—Starter fuses—Cooling water—Flow switches—Normally-open contacts.	
4. INSTALLING THE IGNITRON CONTACTOR—AND KEEPING IT WORKING	23
The case—Electrical connections—Cable size—Thyrite resistor—Water drain—Handling tubes—Operation—Too small load—Copper oxide rectifier—Starter current—"Hard starting"—Igniter resistance—Gassy tubes—Grounds—Maintaining ignitrons—What is "load"?	
5. THE RIGHT LOAD FOR IGNITRON TUBES—RATING. . . . .	36
Ignitron sizes—Reading a chart—Tube-rating charts—Per cent duty—Measuring load—Averaging time—Duty calculations—Tubes for larger loads or special voltages.	
6. INSTRUMENTS FOR CHECKING TUBE CONTROLS . . . . .	51
Bell ringer—Voltmeter, analyzer, ohmmeter—Pointer-stop ammeter—Cycle recorder—Oscilloscope—Magnetic oscillograph.	
7. THE TIME-DELAY RELAY—MEASURING TIME FOR WELDER OPERATION. . . . .	61
Using tubes for timing—Connection diagram—Elementary diagram—Vacuum-tube operation—Potentiometer and voltage	



CHAPTER	PAGE
divider—Capacitors or condensers—Capacitor operation—Time-delay grid circuit—Operating the time-delay relay.	
8. THE THYRATRON TUBE . . . . .	81
Purpose—Types of heated tube—Thyratron and vacuum tube compared to mouse trap and water faucet—Electrons—Grid control—Electron emission from cathode—Thyratron heat, blue light, voltage.	
9. THE AUTOMATIC WELD TIMER . . . . .	93
Arrangement—Squeeze, weld, hold, off times—Time-delay relays combined—Diagrams of weld timer—Circuit operation—Sequence—Grid-to-cathode capacitor.	
10. PULSATION WELDING WITH AUTOMATIC WELD TIMER . . . . .	106
Purpose of pulsation welding—Heat and cool times—Weld interval—Timer diagrams—Double time range—Pulsation-welding cautions.	
11. THE WELTRONIC WELD TIMER . . . . .	115
Arrangement—Transformer connections—In phase or out of phase—Tube circuit—Operation sequence.	
12. MAINTENANCE AND “TROUBLE-SHOOTING” ON WELD TIMERS AND SEQUENCE CONTROLS . . . . .	122
Voltage supply—Where to look for trouble—Vibrating or repeating operation—Wrong time delay—Temperatures—Checking the time-delay circuit—Spare parts	
13. GOOD VOLTAGE FOR THE WELDER. . . . .	129
Importance of voltage changes—How to reduce them—Power transformers—Selecting supply voltage—Cable sizes—Selecting cables or buses—Welders supplied from generators—Using capacitors with welders—Series capacitors.	
14. THE PROBLEM OF GETTING GOOD WELDS. . . . .	141
Special metals—Weld heat—Short-time welds—Current and voltage waves—Power factor—Reactance—Transient currents—Troubles with transients—Synchronous timing.	

## *Part II*

### SYNCHRONOUS CONTROL OF A-C WELDING

15. SYNCHRONOUS TIMING. . . . .	152
Synchronous spot-weld timer—Connection and elementary diagrams (CR7503-A124).	

## CONTENTS

ix

CHAPTER	PAGE
16. A.C. FOR CONTROL; D.C. FOR TIMING . . . . .	162
A-c control power—Supply for control transformers—Flow switch—Indicating lights—5-minute time relay, with mercury-button contact—D-c supply, by rectification and filtering—Safety circuit—Voltage divider.	
17. FIRING THE IGNITRONS; THE POWER CIRCUIT . . . . .	174
Connection of ignitrons and thyratrons—Voltage and current changes—Grid control of firing tubes—Grid bias—Leading-tube-trailing-tube operation.	
18. THE SYNCHRONOUS TIMING CIRCUIT. . . . .	184
Arrangement—Trigger-tube grid circuit—Starting each weld in step—Timing the weld—Other G-E timing circuits—Westing-house spot-weld control (SP-11)—Weltronic control (Model 51)	
19. CONTROL OF WELD HEAT BY TURNING A DIAL . . . . .	200
Changing weld current and heat—Using only part of each cycle—Phase-shift heat control—Diagrams of phase shift—CR7503-D137 used with ignitron contactor—Advantages—Proper use—Load rating of phase-shifted ignitrons.	
20. SYNCHRONOUS SPOT-WELDING TIMER INCLUDING HEAT CONTROL .	220
Elementary diagram (CR7503-A125)—Leading-trailing control—Phase-shifted power—Heat-control accessories—How a transformer works—Peaking transformer—Changing heat during the weld—Compensator—Weld recorder—Sequence controls.	
21. STARTING AND MAINTAINING THE SYNCHRONOUS PANEL . . . . .	240
Installation—Checking—Starting for the first time—Starting the heat-controlled panel—Maintenance—Spare tubes—Inspections—Records	
22. LOCATING TROUBLE . . . . .	253
Probable causes—General location— <sup>e</sup> Tubes at fault?—Checking circuit connections—Using the oscilloscope—Poor voltage—Grounds—Welding operation—Examples of troubles and correction.	
23 SEAM-WELDING CONTROL. . . . .	270
Current interruption—Earlier controls—Seam-welder control with timing chain (CR7503-B102)—Phase-shifted power circuit—Arranging timing buttons—Seam-welding speed—Program welding—All-tube seam-welding control (CR7503-B110).	
24. ALL-TUBE CONTROL FOR SEAM, SPOT AND PULSATION WELDING . .	289
Diagram (CR7503-C107)—Spot-length control—Cool time—Number of impulses.	

























CHAPTER	PAGE
25. WELDER CONTROLS USED WITH SERIES CAPACITORS . . . . .	303
Welder circuit with capacitors—Circuit voltages during weld— Between welds—Synchronous controls (CR7503-A106, -B106)— High-voltage power circuit—Rectified grid voltages—Welder operation with series capacitors.	

### *Part III*

## ENERGY-STORAGE WELDING

26. WELDING WITH STORED ENERGY. . . . .	318
Purpose—Examples of energy storage—Storage in capacitors or in inductance—Comparing energy of pressure and energy of motion.	
27. CAPACITOR STORAGE. TAYLOR-WINFIELD HI-WAVE CONTROL . . .	327
Diagram (Hi-Wave Style 107)—Tube rectifier for charging capacitors—Controlling d-c voltage—Capacitor voltmeter— Selecting capacitors, voltage, transformer ratio—Firing switch— Making the weld.	
28. REACTOR STORAGE. SCIACKY PROCESS . . . . .	339
Arrangement—Three-phase tube rectifier—Phase-shifting the rectifier—Retractable welding head—Sciacky control operation— Changes of electrode pressure—Operating the d-c contactors— Constant weld energy.	
29. GENERAL-ELECTRIC STORED-ENERGY WELDING CONTROL. . . . .	354
Diagram (CR7503-H120)—Power circuit—Control circuits— Six-tube, high-voltage rectifier—Spark gap—Selecting capacitors —The welding operation—Preventing reversed capacitor voltage.	
30. GRID CONTROL OF SIX-TUBE RECTIFIER. . . . .	371
Grid-circuit diagram—Phase-shifting the rectifier—Charging the capacitor—Voltage-regulator tube—Rectifier trickle charge— Voltage Inspector—Gradual rectifier starting.	
INDEX. . . . .	385

## SYMBOLS OF DEVICES

Symbol	Shows or represents	Refer to	
		Section	Figure
	Wires crossing, not connected		
	Wires connected		
	Contact (normally-open), n-o, not condenser	3-15	
	Contact (normally-closed), n-c	3-15	
	Connection to ground	11-4	11C
	Push button		3G
	Transformer winding	1-3	1C
	Coil of contactor or relay	3-14	3G
	Connection terminals		
	Resistor	2-8	
	Fuse	2-10	
	Resistor (with adjustable tap)		
	Potentiometer or resistor (vari- able)	7-10	7F
	Capacitor (or static condenser)	7-12	
	Capacitor, variable	11-4	11C
	Indicating lamp	16-3	16A
	Meter		29C
	Contact, mercury button	16-5	16C
	Welding transformer		
	Ignitron tube	3-4	3C
	Rectifier tube	16-7	16D
	Disk (copper oxide) rectifier	3-7	3G
	Vacuum tube	7-5	7D
	Thyratron tube	8-3	8B



# PART I

## IGNITRON CONTACTORS, TUBES AND WELD TIMERS

### CHAPTER 1

#### THE RESISTANCE WELDER IN YOUR PLANT

Today while you worked in your plant, you may have seen a resistance welding machine—the kind that squeezes together several pieces of metal and passes a “shot” of electricity through them, leaving the pieces of metal stuck together—welded. You understand that some kind of switch closes the circuit to let electricity pass through the pieces of metal. Perhaps it is a magnetic contactor quite like those used in motor starters. But it may be just a metal box holding several steel cans called *tubes*. You probably know that these tubes are called *ignitrons*, or that the whole box is called an *Ignitron Contactor* or Weld-O-Trol. How these tubes work and how these tubes make the welding machine do its job are told here. Arc welding, in which a man bends over a bright electric arc, melting a rod into a pool of metal, is another story. We shall include here only resistance welders, like the spot welder, the gun welder, or the seam welder.

**1-1. Spot or Gun Welders.**—The spot welder is best known. This is the machine that welds metal pieces together at one spot, then opens its jaws before again squeezing the metal pieces at a different place, to make another spot weld. The pieces of metal being welded are usually steel, although we shall see later that other metals can also be welded together. The welding machine (Fig. 1A) holds these steel pieces between two jaws, one of which moves so as to squeeze or release the steel pieces. At the point where each jaw touches the steel, there are pointed pieces of copper (or copper alloys—copper mixed with other metals) called *electrodes*, whose job is to carry the electricity into the steel without themselves becoming too hot. Of course, there are

many different shapes of electrodes for making different welds, but this is not discussed here, except to say that most of these electrodes are cooled by water passing inside them, as shown in Fig. 1A. If the electrodes do not have enough cooling water, they will change their shape when used, and this may ruin the weld.

The spot welder may be a small machine operated by foot pressure or a large machine run by motor or air pressure, but

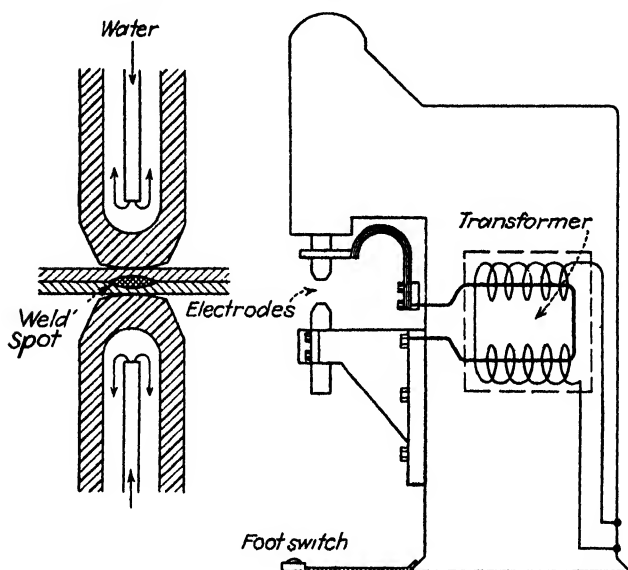

FIG. 1A.—A welding machine, showing circuits and electrode tips.

controlled by a foot switch. Large spot welders may have many sets of electrodes, which work one at a time, to weld special large metal shapes. Most spot welders stand in one place, and the steel or work is carried to them. The gun welder is a spot welder small enough to be moved around the work, as in welding automobile frames. The electricity for all these spot welders is controlled in about the same way.

**1-2. The Seam Welder.**—While the spot welder sews metal buttons in place, the seam welder is the sewing machine for stitching metal sheets together with a row of spot welds so close that they can overlap. To do this, the seam welder has electrodes shaped like thin rolls or wheels, which turn while the

work moves between them. These rolls steadily squeeze the steel sheets between them during the whole seam weld, and they separate only while another piece of work is put in place to be welded. To make a seam weld, electric current usually passes for short times, like stitches, very close together. This requires fancier electric switching than a contactor can do, so seam welders will be described later. For the present we shall study only spot welders controlled by contactors.

**1-3. The Circuit to the Welder.**—Figure 1B illustrates how the electric power gets from the powerhouse to the welder, showing power lines to your plant and a bank of power trans-

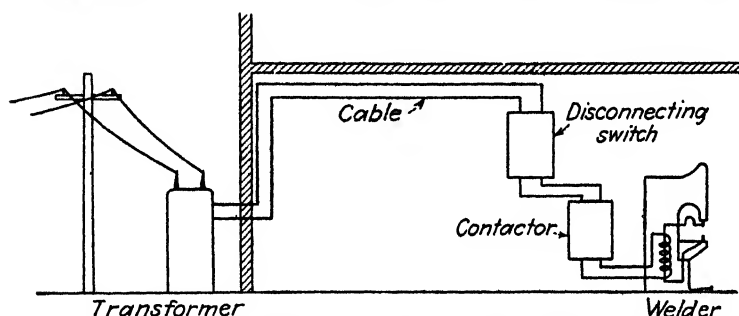

FIG. 1B.—Power reaches the welder through these devices.

formers outdoors to step down or reduce the electric pressure to a usable voltage like 440 or 220 volts. Then comes a fused disconnecting switch, a magnetic contactor, and finally the welder itself. An easier way to show parts of circuits while studying them is to use signs in place of the electrical devices. These signs are called *symbols*, and most electrical workmen agree on them and use them. Using symbols, Fig. 1B becomes Fig. 1C.

In Fig. 1C, power is furnished by the power company to the high-voltage winding of transformer *T*, which reduces the pressure to 440 volts for this plant. Later we shall learn more about this 440-volt circuit and the wire cable *W* that carries this 440-volt pressure to the welder inside your plant. You will notice that two cables run from the power transformer to the welder, instead of three cables generally used for a-c motors and power. This is because spot welders usually operate single-phase, while other power loads are usually three-phase. A spot welder can



get its single-phase power from any two cables of a three-phase feeder. Before you connect the welder to this 440-volt supply, you already know that a disconnecting line switch *D* must be used, with fuses *F* to protect against short circuits. The circuit finally reaches the contactor *C*, which will close the circuit to the welder. This contactor must start and stop the flow of large electric currents (hundreds of amperes), yet this contactor can be closed or opened by controlling only one or two amperes of current in the circuit of the contactor coil *CR*. When the contactor closes the circuit to pass current into the welder, we say that we *energize* the welder.

This welder current does not go directly to the electrodes, but goes to the welding transformer. Figure 1A shows a welding

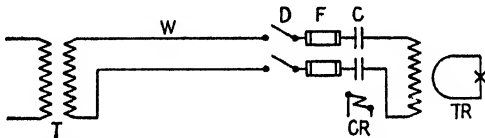

FIG. 1C.—Simple diagram of the power circuit to the welder.

machine with this welding transformer *TR* mounted inside. This transformer has two windings. When the 440-volt winding is energized by the closing of contactor *C*, the other winding gives much greater current (usually 10,000 to 100,000 amperes) at low pressure (2 to 15 volts). This very large current passes through the electrodes and the pieces of steel or other metal being welded. The two windings of the welding transformer are shown in Fig. 1C also, completing the electric circuit from the powerhouse to the weld itself. The signs or symbols used in Fig. 1C are shown also on page xi.

In Fig. 1C, notice that the magnetic contactor *C* closes and opens both sides of the 440-volt line. The welding transformer receives current whenever contactor *C* is closed. To make a single spot weld, contactor *C* is closed for only a small part of a second, and this short time is controlled by some small timing device that energizes (passes current through) the contactor coil. On a motor-driven spot welder, this short time might depend on a cam switch. Other timing devices will be described in Chap. 7.

**1-4. The Magnetic Contactor and the Ignitron Contactor.**—So far you probably know a lot about this welder circuit of Fig. 1C.

Many magnetic contactors are being used to control spot welders and gun welders, and they work well as long as they do not have to work too quickly. But for controlling a welder drawing thousands of line amperes, a magnetic contactor may have to be so large that its moving parts cannot move fast enough to give short-time welds. Such a contactor may cause too much noise and maintenance. Magnetic contactors will continue to be used with welders, but meanwhile a faster and noiseless contactor is being installed more and more. It is the Ignitron Contactor, also called the Weld-O-Trol.

If you have seen an ignitron contactor (see Fig. 3A on page 14), you know that it is built as a metal box containing two metal cylinders or cans, along with a fuse and other gadgets. These two metal cans are ignitron tubes, which can carry hundreds or thousands of amperes of current right through their insides. These two tubes together work just like a single-pole magnetic contactor, but the tubes can close and open the line circuit to the welder without moving or making any noise. Also, these tubes are very fast in operation and need very little attention or service. To learn just how these ignitron tubes work, we must wait for Chapter 3, where we shall also see how the ignitron contactor is connected into a circuit like that in Fig. 1C.

But before we can pull an ignitron apart to see what makes it tick, we must get a few tools and measuring sticks to help us understand what goes on. We will also need to know something about alternating current (a.c.), with which the ignitrons will be used.

## CHAPTER 2

### ALTERNATING CURRENT FOR THE WELDER

All spot welders get their electricity from the a-c lines in the plant. So do most motors. But when you are connecting and taking care of motors, you do not have to think about the very fast changes in the electric pressure, as often as 50 or 60 times each second. All you need is a voltage tester to tell you that the motor is getting its "juice" at all three leads or connections. If the motor turns the wrong way, you reverse two of the leads. Since the motor needs half a second to reach full speed, you need not worry about what the electric supply is doing during each small part of a second.

**2-1. Very Short Time.**—With tubes like the ignitron, we need to know what the alternating current (a.c.) does during times as short as  $\frac{1}{60}$  of a second. Ignitrons work so fast that they can turn the current on and off more than thirty times each second. To make a weld, the current usually flows into the welder for less than  $\frac{1}{5}$  of a second. So, when we talk about the ignitron contactor, we shall be using small parts of a second, and we shall soon get tired of using fractions like  $\frac{1}{60}$  or  $\frac{1}{5}$ . Therefore, just as we say 10 seconds instead of  $\frac{1}{6}$  of a minute, let us start to say 10 cycles instead of  $\frac{1}{6}$  of a second. Where does this cycle come from, and how long is a cycle of time?

**2-2. The Cycle.**—Most of the a-c electricity used in the United States is made at 60 cycles per second. During each second the flow of current in any circuit changes direction so often that it flows in one direction 60 times each second and in the opposite direction 60 times each second.\* A cycle is the length of time needed for the electricity to flow just once in each direction. So, if your electricity is supplied at 60 cycles a.c., then one cycle of time is  $\frac{1}{60}$  of a second, just as 1 second is  $\frac{1}{60}$  of a minute. All through this book, 60 cycles a.c. will

\* The flow of current does not change direction like this in a direct-current (d-c) circuit; as explained in Sec. 2-4.

be used, so a cycle of time will be  $\frac{1}{60}$  of a second.\* Most welds in steel can be made in 4 to 10 cycles of time, but the welding of some metals, like aluminum or brass, may need only 1 or 2 cycles. You can hardly imagine a big 600-ampere magnetic contactor trying to close its contacts for only 2 cycles, or  $\frac{1}{30}$  of a second. Instead, ignitron tubes are used because in less than 1 cycle of time they can easily close and open a circuit carrying thousands of amperes.

**2-3. Cycles and Tubes.**—The whole working of an ignitron tube depends upon what the tube does during each separate cycle of time. Whatever it does during one cycle, the tube merely repeats over and over during other cycles, as long as it is not told to change. But, while it is passing large current during one cycle, the ignitron can be told to stop passing current for the cycle following, and the current will stop. In Chap. 3 we shall learn how to tell the ignitron what to do, by controlling its igniter circuit.

**2-4. The A-c Curve.**—Since the ignitron tube may do a different job during one cycle than it does during another cycle, it will be handy to know how to draw a picture to show what happens during each cycle. This can be done, and Fig. 2A shows how the alternating-current changes† during several cycles of time. The heavy curved line represents the amount of electricity in any circuit such as the welder transformer shown to the right. Starting at the left side of Fig. 2A, at the point A, there is no electricity at just that instant when the curved line crosses the straight line, which is marked 0 at each end. But

\* In places like parts of California, where electricity is made at 50 cycles a.c., there will be 50 cycles during each second. There each cycle would be  $\frac{1}{50}$  of a second, or a slightly longer time than 1 cycle of 60 cycles a.c. However, since tubes do their job during each separate cycle, and do not care whether they have to do this job 50 times or 60 times each second, this book can be used for 50-cycle electricity also.

† As an interesting way to show that a.c. does change direction so rapidly, get a Type S-14, 2-watt, 115-volt neon glow lamp at an electrical supply house. Put it in a socket on an extension cord. Turn on the lamp, hold it still and you see no flicker of the light. Then, holding the lamp so the crack between the half-circle metal plates is horizontal, swing the lamp quickly from side to side through a space of several feet. If swung at the right speed, the lamp will look like the curved part of Fig. 2A. One-half of the lamp is lighted when current flows in one direction; the other half lights when current flows in the opposite direction.

when the curved line gets to point *B*, the curve is at its highest point above the 0-0 line, and this means that the electricity is flowing in one direction, as from line 1 down through the transformer winding to line 2. Following the curve down to point *C*, the curve crosses the 0-0 line and again there is no electricity. But when the curved line reaches point *D*, the electricity is going in the direction opposite to that at *B*. The electricity moves now from line 2 up through the transformer winding to line 1. There is no electricity again at point *E*, nor at *G* or *J*. Starting at *A*, 2 cycles, or  $\frac{2}{60}$  second, have gone by before point *J* is reached.

Each "hill" above the 0-0 line, like *ABC* or like *EFG*, stands for time a half-cycle long. Each "valley," like *CDE* or *GHJ*,

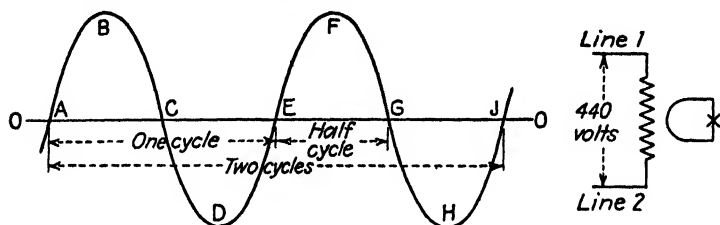

FIG. 2A.—Alternating-current changes during cycles of time.

is also a half-cycle of time. To keep things straight, we call the hills positive half-cycles; the valleys are negative half-cycles. During the positive half-cycles, electricity moves from line 1 to line 2; line 1 can be marked plus (+), and line 2 is minus (-). On anything that is being run by electricity, like this welder transformer of Fig. 2A, the electricity always tries to move from (+) to (-). During negative half-cycles (valleys) when the electricity is moving from line 2 to line 1, line 2 is marked (+) and line 1 is marked (-).

To compare with Fig. 2A for alternating-current (a-c) supply, you will want to know about direct current (d.c.), which is used for various purposes, as motors, plating, batteries, etc. With d-c power supply, the electricity does not change direction, but moves steadily from one power line through the load to the other power line. Current flows from the (+) line to the (-) line, but the lines do not change signs as they do with the a-c power supply. Ignitron tubes will let direct current flow through

them, but cannot stop this current when desired. Therefore, ignitron contactors are not used in d-c circuits.

**2-5. One-way Current.**—At this point you may ask why one should care about these curves, or care about which way the electricity goes. It is quite true that electricity will go either way through this welding transformer, or through a motor, a wire, or the contacts of a magnetic contactor. But these ignitron tubes will not pass electric current in either direction, as through a wire; they pass current in only one direction. If just one ignitron tube is used, it can pass current during all the positive half-cycles of Fig. 2A, or it can be connected so it will pass current during all the negative half-cycles, but it cannot pass both positive and negative half-cycles, for that would be passing current in both directions through the same tube. In order to pass current during both the positive and negative half-cycles, we have to use two tubes, properly connected. Now you see why two ignitron tubes are used in the ignitron contactor, even though the tubes together control only one side of the power line. One ignitron passes current in one direction (during positive half-cycles). The second ignitron passes no current during these positive half-cycles, but it does pass current during the negative half-cycles.

The two ignitrons do not both pass current at the same instant, but alternate—first one, then the other—every half-cycle. When you see them work, watching the blue light inside them, they appear to start together and stop together, but that is because human eyes are not quick enough to see these small differences of only half a cycle ( $\frac{1}{120}$  second). There are electrical instruments that are fast enough to show how each ignitron works during its own half-cycle (see Chap. 6). In order to know what makes the ignitron work, we have to know how the a-c wave is changing, as in Fig. 2A, and we must know what else happens during each half-cycle when the ignitron is expected to work.

We said that in Fig. 2A the electricity was changing like the curved line. Later on, we must show that there are two curved lines, one of which shows the electric pressure (*volts*), while the other curve shows the electric current (*amperes*). That point will be taken up in Chap. 13. For the present, we must learn the meaning of volts and amperes in any electrical circuit.

**2-6. What Are Volts and Amperes?**—Most plants use either 440 volts or 220 volts a.c. for their power and 110 volts a.c. for lighting. Each of these three numbers shows the amount of electric pressure between the feeder cables or wires, just as a water pipe might supply water at 30 pounds per square inch pressure. If you wanted to get one gallon of water each minute through a garden hose 50 feet long, the 30 pounds water pressure in your house pipe could easily give the force needed. But, if you wanted to get 100 gallons of water each minute through a hose 500 feet long, you would call the fire department. They would use a big fire hose, and they would have to boost the pressure with their pumper before they could force all this water through such a long hose. Also, for good fire fighting, the water should leave the hose with enough force to reach high and hit hard. Pressure is needed to force the flow of water through the resistance of the hose. A smaller opening or longer hose opposes or resists the flow of water still more. We say that the hose has a certain amount of *resistance*, and a long hose has more resistance than a

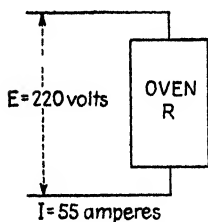

FIG. 2B — Circuit through resistance of oven.

short hose. In the same way, you must have good electric pressure to be able to get enough electric current to flow through the cables and still do the work at the welder. Electric pressure is measured in *volts*, and electric current flow is measured in *amperes*.

**2-7. Resistance.**—Suppose you had an electric oven (Fig. 2B) operating at 220 volts pressure and taking 55 amperes from the two cables (single-phase). What is it that tells the oven how much current to take, or prevents more than 55 amperes from flowing? It is resistance. Everything has a certain strength to resist the flow of electricity, just as a long hose will resist the flow of water through it. The electric circuit through the oven resists the flow of electricity, and the amount of this “strength-to-resist” can be figured, to give us the oven’s amount of resistance. Resistance is measured in ohms. How much resistance does this oven have? Divide volts by amperes to get ohms:  $220 \text{ volts} \div 55 \text{ amperes} = 220/55 = 4 \text{ ohms}$  of resistance. Electrical engineers are so busy (or lazy?) that they do not write out these words. Instead of volts pressure, they use just the letter *E*. For amperes of current

they use  $I$ , and for ohms of resistance they use  $R$ . This is very handy when you can merely write  $E = I \times R$  and have the circuit "in a nutshell." Try it and see.  $E$  is 220,  $I$  is 55,  $R$  is 4.  $220 = 55 \times 4$ .

**2-8. Resistors.**—As we have just explained, everything has some ohms of resistance, and it will therefore be necessary to say a great deal about resistance. In some circuits things called *resistors* must be used; these resistors are made with certain amounts of resistance, such as 10 ohms, 500 ohms, 2000 ohms and other amounts. For very great amounts of resistance another name may be used. For example, 1,000,000 ohms may also be called 1 megohm. A "5-meg" resistor is 5,000,000 ohms. A 1,000,000-ohm resistor is usually smaller than a pencil stub. A 10-ohm resistor may be as small as a fountain pen, but is more likely to range in size anywhere from 2 inches across to 3 feet across, because of the large current it usually carries.

**2-9. Heat from Electricity.**—When electric current passes through resistance, heat is produced. The electric oven could not become hot if it did not have resistance built into it. The oven uses *power*. How much? The engineer says: Power =  $EI$ . As you did above, put the numbers of volts and amperes in place of  $E$  and  $I$ . Power = 220 volts  $\times$  55 amperes = 12,100 watts. Divide this by 1000 and you get 12.1 kilowatts. A kilowatt (kw) is the same as 1000 watts.

**2-10. Fuse.**—What is a fuse? We all know a fuse is usually a little strip of lead metal, made so that it will carry a certain amount of current. A 100-ampere fuse will carry 100 amperes of current steadily, but it will "blow" if much more than 100 amperes tries to go through it. But just how does the fuse "blow" and open the circuit, stopping the current before damage is done? It all happens very fast, but we know that the fuse gets so hot that it melts. As in the case of the oven above, this heat gets into the fuse because current is passing through the resistance of the fuse. The fuse is made of lead or other metal chosen because it has high resistance and melts easily.

**2-11. Heat to Make a Weld.**—Now a very important question—how are pieces of metal welded together in a spot welder? The pieces get so hot (just at the spot between the electrodes) that the metal softens and flows, joining the pieces in a drop of hot metal which then becomes solid and strong as it cools. Just



as heat was produced in the oven or in the fuse above, the heat is produced in the spot weld because of current passing through the resistance of the metal between the electrodes. If this metal had no resistance, no heat could appear in the metal to make the weld. Since the weld heat depends so much upon the resistance of the material being welded, this process is called *resistance welding*, whether it is done by a spot or gun welder or by a seam welder. This welding heat will be discussed further in Chap. 14.

**2-12. Large Current for Welding.**—At best, the amount of resistance in pieces of metal being welded is pretty small. To produce enough heat to weld, there must be a very large current flow through the metal, probably from 10,000 to 100,000 amperes. It would be foolish to think of drawing such large currents directly from the 220-volt or 440-volt power line. Moreover, we need less than 15 volts to force this large current through the low-resistance circuit of the welder. So how is it done? By the welding transformer (described in Sec. 1-3). Any transformer can change a.c. of one voltage and current into a.c. of another voltage and current. The product of volts  $\times$  amperes must be about the same in each transformer winding. For example, a welder using 20,000 amperes at 4.4 volts at the electrodes draws from the transformer  $20,000 \times 4.4 = 88,000$  volt-amperes. To be able to do this, the transformer must draw enough current from the 220-volt line so that

$$220 \times \text{current} = 88,000.$$

Then  $88,000/220 = 400$  amperes current drawn from the 220-volt line.

**2-13. Kva.**—In the transformer just described, notice that the current and voltage are multiplied together to give 88,000 volt-amperes in the circuit at the welder electrodes, and also about 88,000 volt-amperes in the line circuit to the welder. In Sec. 2-9 we learned that  $EI$  (volts  $\times$  amperes) showed the amount of power. This 88,000 volt-amperes gives an idea of the power or size of the welder or its load. For convenience, we divide this amount of volt-amperes by 1000, and this gives us  $88,000/1000 = 88$  kilo volt amperes ("kilo" means 1000). Using the initial letters, we say that 88 kva shows the amount of power passing through the welder. [True power in kw requires that  $EI$  should be multiplied by the power factor (see Sec. 14-5)].

In the same way, a 100-kva transformer is built to carry a load of 100 kilovolt-amperes, which can be either 227 amperes at 440 volts or 22,700 amperes at 4.4 volts.

$$\text{kva} = \frac{\text{volts} \times \text{amperes}}{1000}$$

In a resistance load as in an electric oven, kva is the same as kw. In welder circuits there is a difference, but we shall leave that for Chap. 14.

Now we are ready for the ignitron contactor.

## CHAPTER 3

### THE IGNITRON CONTACTOR

The ignitron contactor is a switch for closing and opening the electric circuit to a spot welder or similar equipment. As mentioned in Sec. 1-4, the ignitron contactor includes two ignitron tubes which work like a single-pole magnetic contactor, but

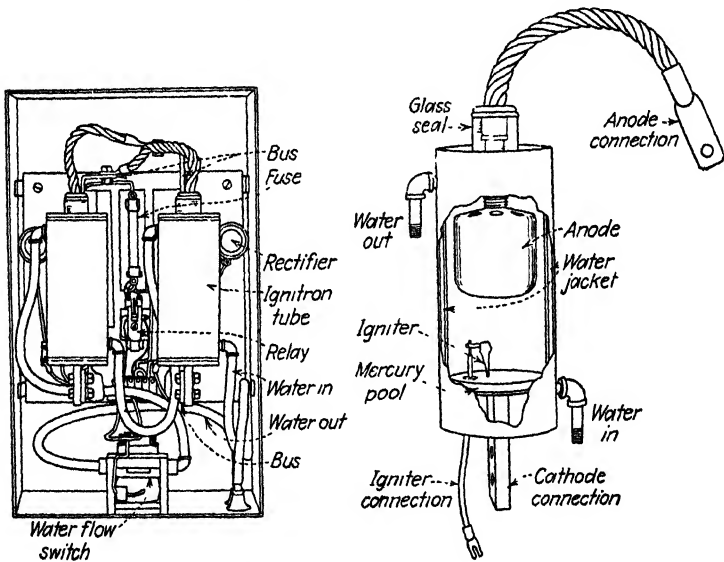

FIG. 3A.

FIG. 3A.—Complete ignitron contactor.

FIG. 3B.—Ignitron tube, cut away to show inside.

without movement or noise. These two tubes are almost the whole device, and any other parts are there only to hold or protect the ignitrons. Figure 3A shows the heavy copper busses or straps to which the ignitrons are bolted, and the size of these busses indicates the large currents that these tubes can carry. In the circuit that controls these ignitrons there are two copper oxide rectifiers, a fuse and also a water-flow switch, all described

later. These parts are connected by wires to the ignitron tubes, as shown in Fig. 3D. Now we must see what the inside of an ignitron tube is like and how it works.

**3-1. Current—In Here, Out There.**—If part of an ignitron tube were cut away to show the inside, the rest of the tube would look like Fig. 3B. The line current enters the ignitron through the flexible copper cable at the top, and the current leaves the ignitron through the solid copper bar at the bottom. But how does the current get from the top to the bottom? The ignitron has no moving parts and does not have any metal-to-metal contacts like the tips of the usual contactors. Instead, the large space inside the ignitron is full of mercury vapor or gas, and is carefully sealed so no air can get in. This mercury vapor can be made to pass current right through the space inside the ignitron. The mercury vapor comes from the pool of liquid mercury that lies across the bottom inside the tube.

**3-2. Anode, Cathode and Igniter.**—Figure 3B shows that the top of the tube is called the *anode*, while the bottom part is the *cathode*. (We shall be using such names of tube parts all through the book, so now is the time to start learning them.) The line current passes from the anode to the cathode through the space inside the tube. To control the ignitron tube and make it close or open the line circuit, there is a starter, or *igniter*, which dips into the mercury pool. This igniter starts the current flow through the ignitron tube just as a spark plug starts the explosion inside an automobile-engine cylinder. To make the ignitron fire or pass the large line current, a small control current must pass into the starter and pass from the starter tip into the mercury pool.

**3-3. Electron Tubes.**—In Sec. 2-5 it was pointed out that line current can flow only one way through the ignitron tube. Current flows from top to bottom (from anode to cathode) and never flows from cathode to anode. The line current flows through the pool of mercury that lies at the bottom and forms part of the cathode of the tube. The reason why current can flow only one way through a tube is explained in Sec. 8-7, where it is shown that electrons can enter the mercury vapor only from the mercury pool. These electrons are tiny electrical charges that make it possible to pass current through the space inside the tube. That is why these tubes are called *electron tubes*.

**3-4. Ignitron Symbol.**—To show an ignitron tube on a circuit diagram, a single picture or symbol is used, as shown in Fig. 3C. The dot inside of the circle means that this tube contains vapor or gas and is, therefore, not like a vacuum tube (for which no dot would be used).

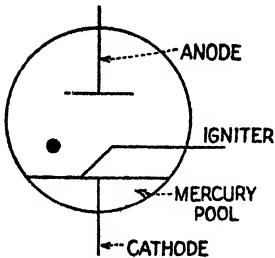

FIG. 3C.—Symbol for ignitron tube.

**3-5. Ignitron Construction.**—As shown in Fig. 3B, the ignitron tube has walls of steel, solidly joined to the bottom or cathode connection of the tube. The anode is made of graphite (carbon) and is held in place by a special glass seal, which also separates and insulates the anode connection from the rest of the tube. The igniter or starter is a piece of special material, which is pointed so that its tip dips slightly into the mercury pool. The igniter connection is a separate small wire, which passes through the bottom of the tube and is insulated by a glass bushing.

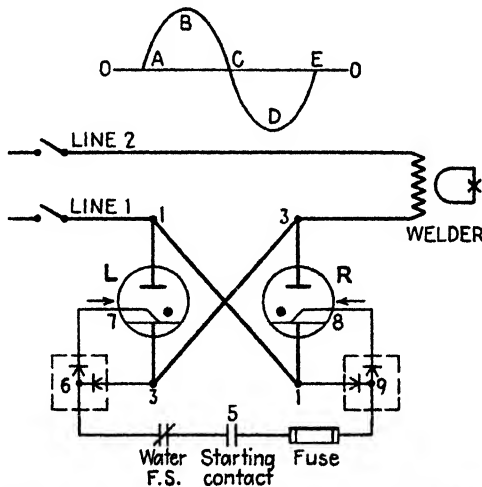

FIG. 3D.—Circuit of ignitron contactor, with a-c wave.

**3-6. The Ignitron Contactor Circuit.**—Figure 3D shows the usual way to connect a pair of ignitron tubes when they work alone to control a welder, as in the ignitron contactor. Notice that one line goes directly from the a-c supply to the welder

transformer, while the other line is connected to both ignitron tubes. To find out how the current passes from one line to the other, through the tubes and the welder transformer, we must keep in mind the a-c curve described in Sec. 2-4 and shown again in Fig. 3D. When the a-c curve crosses the 0-0 line at point *A*, there is no current flow. But an instant later, at point *B*, the current will flow in one direction. Let us say that the current is now trying to flow from line 1 through the welder transformer and back to line 2. To do this, the current must also flow through one of the ignitron tubes. Remember that current can flow only from top to bottom, anode to cathode. Starting from line 1, current can pass down through tube *L*, but cannot pass up through tube *R*. So at instant *B* current flows from line 1 through tube *L* to point 3, through the welder transformer and back to line 2. At instant *C* again there is no current flow. A little later at *D* the current has reversed its direction, so that it now flows from line 2 through the welder transformer and tries to reach line 1. To do this, the current cannot pass up through tube *L*, but it will pass down through tube *R*. Of course, tubes *L* and *R* will pass line current only if current is first forced into their igniters. This point must be studied next.

**3-7. Protecting the Igniters.**—Current can be made to pass in either direction between the igniter and cathode, but the igniter will be damaged if current flows from the mercury-pool cathode into the igniter. Therefore, the starters or igniters must be protected by devices that permit current to flow into the igniter connections but not out of them. In Fig. 3D the igniters are protected by adding copper oxide rectifiers at 9 and 6. These rectifiers, shown in Fig. 4B, consist of stacks of copper disks specially treated so that they will pass full current in the direction of the arrows but will pass very little current in the opposite direction (see Sec. 4-12).

**3-8. Tracing the Circuit.**—In Fig. 3D, the ignitrons are "fired," or made to pass line current, by closing the small contact at 5. Then, during the upper half *ABC* of the wave, the current first flows from line 1 through rectifier 9, through the fuse and contact 5, up through rectifier 6 and into igniter 7, into the mercury pool of tube *L* to point 3 through the welder transformer and back to line 2. This igniter current will make tube *L* fire, passing the load current directly from line 1 to 3. Similarly, during the

lower half *CDE* of the wave, the current flows first from line 2 through the welder transformer to 3, through rectifier 6 and contact 5, through the fuse, through rectifier 9, through igniter 8, into mercury pool of tube *R*, to line 1. This igniter current fires tube *R*, which passes load current direct from 3 to 1.

**3-9. Starter Fuses.**—As soon as line current flows through the ignitron tube, the voltage across the tube decreases to only 15 or 20 volts, called the *arc drop*.\* † This small voltage cannot force current through the starter or igniter circuit, so the igniter current stops as soon as the main line current flows. ‡ If the ignitron should fail to pass line current, the starter current would continue to flow and would overload the starters and rectifiers in the starter circuit. To prevent damage and to tell when the ignitrons are not firing properly, a 6-ampere† fuse is used in the starter circuit. The starter current is 15 amperes or more, which would blow the 6-ampere fuse. When the ignitron tube is firing properly, this starter current flows during such a small part of each a-c cycle that it does not blow the fuse.

**3-10. Water for Cooling the Tubes.**—Since the ignitron tube handles such large currents, it produces much heat that must be removed. To remove this heat, most ignitron tubes require cooling water which flows through a space between the inner and outer walls of the tube. Some small ignitrons have single walls and are held by heavy metal clamps, which tightly surround the bottom of the tube cylinder. In this case, the cooling water passes through the metal clamps, removing the heat which is carried from the tube into the clamp. The amount of cooling water necessary for proper operation is given in Sec. 5-11.

**3-11. The Water-flow Switch.**—Since it is so important that the right amount of water be used to cool the ignitrons while they are operating, most ignitron equipments also include some kind of water-flow switch mounted inside the ignitron enclosure. This

\* When current flows through any tube containing mercury, this current is an electric arc between the anode and cathode and causes the blue glow in the tube. The voltage measured across this arc is about 15 volts and changes very little when the amount of current changes.

† The fuses used in the starter or igniter circuit may possibly be 3-ampere, 6-ampere or 10-ampere fuses. In a Weld-O-Trol, 10-ampere fuses are often used. In a G-E Ignitron Contactor (where only one fuse is used to protect a pair of ignitron tubes), a 6-ampere fuse is correct and may be used, even if a 3-ampere fuse was originally furnished.

flow switch is built so that, when there is not enough water flowing through it, the switch opens a contact in the electric control circuit and prevents the ignitrons from firing or passing line current. If such a water switch were kept closed merely by the water pressure, the switch would still let the ignitrons fire even when the outgoing water pipe was plugged shut, for there would still be water pressure in the ignitrons, but no water flow. The water-flow switch must be operated by the actual movement or flow of the water.

**3-12. Thermal Flow Switch.**—One kind of water switch often used is called the *thermal* or *thermostatic* flow switch because it includes a thermostat. The thermostat contains a special strip of metal which opens an electric circuit when the strip gets hot and closes the circuit again when the strip cools. The thermostat holds this strip against a block of metal, which has a hole through which the ignitron cooling water is flowing. When used with small tubes, the thermostat is sometimes mounted against the metal block that clamps around the ignitron tube itself. Here the thermostat is worked directly by the temperature of this tube clamp. More often, the thermostat is mounted against a separate metal block or pipe through which the water passes after it has left the ignitron tubes. In this case, the metal block or pipe is purposely heated by electricity and then this heat is carried away by the flow of water. The water must pass through the pipe fast enough to prevent the pipe from getting hot enough to trip the thermostat, or else the thermostat opens its contact and shuts off the line current through the ignitrons. If the water flow stops for any reason whatever, the water left in the flow-switch pipe will gradually be heated by electricity until the thermostat trips open. Or, if there is some water flow, but not enough to cool the ignitron tubes safely, the water will be warmer when it leaves the ignitrons and will let the pipe get hot enough to trip the thermostat. In any case, a sudden change in the amount of water flow does not quickly work the thermostat. Water flow can stop for 10 seconds (often longer) before the thermostat gets warm enough to trip. This prevents unnecessary shutdowns in plants where water pressure changes or stops.

A complete thermostatic flow switch (see Fig. 3E) may include a small transformer, whose job is to produce the heat in the



stainless-steel pipe to which the thermostat is attached. The transformer has two high-voltage windings, which must be connected correctly to operate at the line voltage. This transformer works like a tiny spot-welder transformer. It takes electricity from the 220- or 440-volt line and transforms, or changes, it into a large current at low voltage. This large current produces heat in the water pipe as the current passes through the resistance of the pipe metal (just as a large current produces heat inside metal during a spot weld; refer to Sec. 2-11). In Fig. 3G, a thermostatic flow switch is connected to protect the tubes in an Ignitron Contactor or Weld-O-Trol. The transformer may operate continuously across the line as long as water

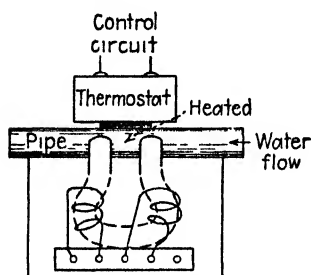

FIG. 3E. - Thermostatic water flow switch.

is cooling the pipe properly. However, in order to prevent overheating of the pipe when water flow stops, the thermostat has an extra contact which trips to open the line circuit to the transformer. After water is shut off, if power is left connected to the thermostatic flow switch, the thermostat will continue to open and close its contacts about every 5 minutes.

A recent design of thermal flow switch does not have a transformer, but uses small resistor heaters built into a block of lead through which the ignitron cooling water flows. The thermostat is mounted against the lead block.

**3-13. Quick-acting Flow Switch.**—Another kind of water-flow switch protects the ignitron tubes and operates instantly when the water flows too slowly. In this switch (Fig. 3F) there is a movable part *A* pivoted at *B*. The flowing water pushes against *A*, making it move or pivot so as to release a small *micro-switch* *M*, which then closes a circuit to let the ignitrons work. The micro-switch contains a contact which is opened or closed by very small movements of its operating pin and which is closed when there is no pressure against the operating pin. When the water flow decreases, it does not push hard enough against *A*, so *A* moves back to the left (because of the spring *S*) and the pin is pushed down, opening the micro-switch contact and stopping the firing of the ignitrons.

**3-14. Control Relay with Low-voltage Coil.**—The circuit of Fig. 3G includes a thermostatic flow switch and also an extra control relay *CR* such as is often mounted on an ignitron con-

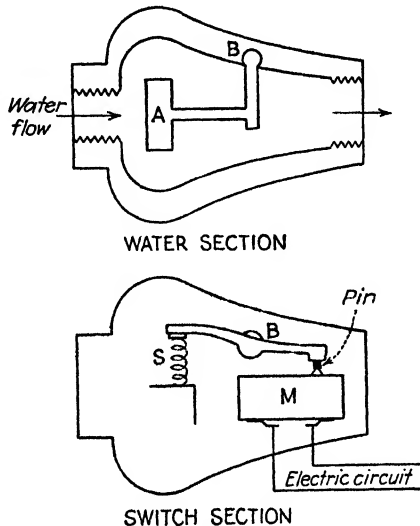

FIG. 3F. Quick-acting water flow switch.

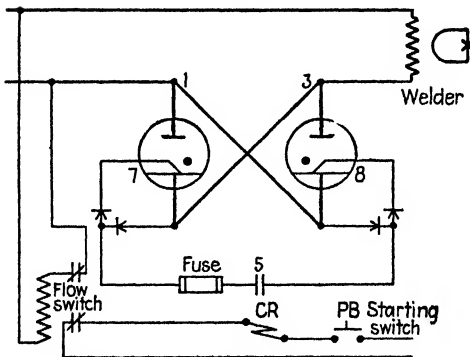

FIG. 3G.—Circuit of ignitron contactor, including flow switch and control relay.

tactor. The contact of *CR* closes the circuit at 5 to make the ignitrons “fire.” This relay *CR* is needed whenever a lower voltage, such as 24 volts or 110 volts, is used on the circuit through the push button *PB* to give greater safety to the welder operator. The relay coil of *CR* operates at this low voltage, but

its contact 5 works at the 220 or 440 volts of the ignitron circuit. The flow-switch contact is in the low-voltage coil circuit. When the thermostat trips open, it stops the current flow in the *CR* coil, or we say it *deenergizes CR*. So *CR* opens its contact 5 and prevents the ignitrons from firing.

**3-15. Normally-open or Normally-closed Contacts.**—Notice that the symbol for the *CR* contact 5 is just two lines with space between them, while the flow-switch contacts in Fig. 3G have an extra line slanting across the first two lines. These symbols show that contact 5 is open, but the flow-switch contact is closed. All contacts on a diagram are shown just as they are when there is no electricity connected to the equipment. A contact like 5 is called a normally-open contact, or n-o contact, for contact 5 is open when there is no electricity connected to *CR*. In the same way, the flow-switch contact is called a normally-closed contact, or n-c contact, for this kind of contact is closed whenever no electricity is connected to any part of the flow switch (or when the thermostat is at normal room temperature). These symbols are shown with many others in the front of the book.

## CHAPTER 4

### INSTALLING THE IGNITRON CONTACTOR—AND KEEPING IT WORKING

When you install or operate any tube equipment, be sure to know and follow the instructions furnished by the maker of that equipment. This book merely explains or adds to those instructions.

**4-1. Installing the Case.**—The enclosing case and panel of the Weld-O-Trol or Ignitron Contactor should be fastened into place before any tubes are mounted in them. The case is mounted like any enclosed magnetic contactor, where it will not

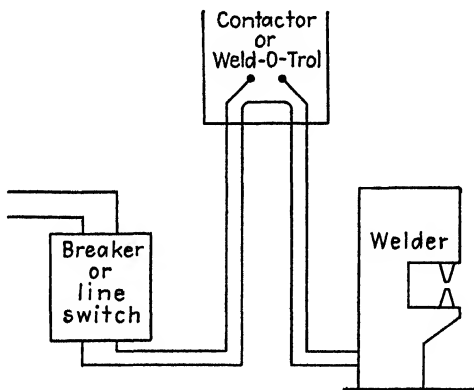

FIG. 4A.—Cables connecting to contactor and welder.

be in the way of production but where one can still get to it easily for checking. It must be vertical so that the ignitrons will be held straight up and down. Do not fasten the case to a machine or support that shakes very much, for this vibration can damage the tubes. Also remember that ignitrons use cooling water, which must not be allowed to freeze in them.

**4-2. Electrical Connections.**—As shown in Fig. 4A, the two cables bringing the main power supply must pass through an air circuit breaker or a fused line switch before going to the contactor

and welder. Since only one cable passes current through the Ignitron Contactor or Weld-O-Trol, which may be some distance from the welder, you might wish to run the other cable direct from the line switch to the welder by the shortest path. Don't do it. Those cables must run together, side by side, always in the same conduit. Right beside the cable to the Weld-O-Trol place the other cable, carrying it into the case of the Weld-O-Trol if there is room, and out again.

**4-3. Size of Cables.**—These line cables must be large enough for the job. By this we mean that the cables must carry the large current to the welder without getting too hot, and the cables must also be large enough to prevent the voltage from dipping or decreasing too much at the welder. Just as a large fire hose is needed to carry a big stream of water and still give good water pressure far from the hydrant, so large cables are required to keep electric pressure (voltage) high at the welder while the weld is being made. The farther the welder is from the main power transformers, the larger the cables must be. This may not be so important with small welders, such as a 50-kva welder drawing 400 amperes, but it is necessary to run big cables for a 200-kva spot welder if it is 300 feet from the power transformer. Be sure they are *big*. Even at 110 volts, 1,000,000-circular mil cables may be needed and they should lie close together for their entire distance. This will be explained further in Chap. 13, but you should be able to see now why the Ignitron Contactor or Weld-O-Trol has such large cable connections or terminals.

**4-4. The Discharge Resistor—Thyrite.**—Whenever ignitron tubes are used to pass current to a welder transformer, some kind of discharge resistance must be connected across the terminal leads of the welder transformer to protect it from very high voltages. Such a resistance was not needed when a magnetic contactor was used, therefore this resistance is furnished along with new ignitron equipment. It may be a box holding as much as 600 ohms of resistor units, or it may be a biscuit-size cylinder called a *thyrite resistor*. Thyrite is a special material often used in lightning arresters, and it has much lower resistance at high voltages than it has at low voltages. It could act like a 2500-ohm resistance in a 440-volt circuit, but it would pass as much current as an ordinary 200-ohm resistance if the voltage

suddenly increased to 880 volts. There can be a voltage jump like this in a welder circuit with ignitrons, as explained on page 147. Such high voltage could hurt the welder transformer windings, but this voltage is decreased by the resistance box or thyrite.

*Warning:* This discharge resistance or thyrite must be connected within 6 feet of the welding transformer\* if it is to do any good.

**4-5. Water Connections.**—For cooling the ignitron tubes, run a pipe from a supply of clean water (which will not cause too much scale, corrosion, pitting or foaming), never warmer than 80 to 90 degrees F. Cooler water is better. The actual temperature and the amount of water needed is shown in the instruction book. Since  $1\frac{1}{2}$  gallons of water per minute or more is needed for cooling ignitrons, use a  $\frac{1}{2}$ -inch or larger water pipe. A strainer should be added in the water line to keep dirt out of the ignitrons. To save water and inconvenience, place two hand valves ahead of the strainer. One valve is set to pass a little more than the required amount of cooling water, and is left in this position by removing the valve handle. Water is then turned on or off by turning the second valve wide open or closing it completely.

**4 6. Open Drain.**—The water pipe from the ignitrons and flow switch should empty into an open-sight drain or funnel. Where several welders are working close together, a larger drain pipe will be needed than usual, to carry both the ignitron cooling water and the water used in the welders. Many plants use a closed-return water system, which can cause back pressure, and this will reduce the amount of water flowing through the tubes. It is worth the trouble of installing the drain to be able to see the water emptying into an open drain. The ignitron tubes can be overheated and damaged by lack of cooling water, just as easily as they can be damaged by overload. Tubes must not be overloaded or mistreated, any more than other electrical equipment.

**4-7. Handling the Ignitron Tubes.**—When you are ready to open the packages containing the tubes, it is also time to get spare fuses to replace those that will blow if you have any tube

\* When an autotransformer is used with the welding transformer, connect the thyrite resistor across the terminals of the main welding transformer.

trouble. This may include the small fuses\* in the igniter circuit, as well as the larger fuses in the main line switch, unless you are lucky to have an air circuit breaker instead. A spare ignitron is nice to have around.

The ignitron tubes must be handled carefully to prevent damage. Although the tube is mostly steel, yet the glass seal at the top of the tube can be easily broken by bumping or dropping the tube. The tube should not be handled by the flexible copper connection at the top, or by the smaller igniter connection below. Also, since the liquid mercury inside the tube is very heavy, it can damage the igniter if the tube is tipped or turned too suddenly. For these reasons, each ignitron tube is shipped separately, in a container that should not be dropped or tipped. A damaged tube cannot be repaired.

Most ignitrons are supported by bolts through the heavy copper bar at the bottom, connecting the tube to a solid bus. The tube must be used in a vertical position, so that the mercury pool will be spread evenly on the bottom of the tube. The flexible copper connection at the top of the tube is bolted to a bus different from the one that supports the bottom of the tube. This top lead should be loose so that it does not pull on the glass seal. To be sure that this top connection is loose, when first attaching it to the bus, hold the copper with one hand just above the glass seal and untwist the copper one turn with the other hand. The wire connection to the igniter should be fastened to the starter terminal with the wing nut before the line switch is closed.

**4-8. Operation.**—When all electrical and water connections have been finished and checked, the equipment may be tried. Before closing the line switch, see that the welder head is up, with electrodes separated. Also, take out the 6-ampere fuse on the panel. Close the line switch, and remember that the entire metal surface of the ignitron tube is now at line voltage, or “hot.” Do not touch the tubes unless the line switch is open.

The first trial is a check to be sure that both ignitrons are good. With the welder transformer set on a middle tap and the line switch closed (the panel fuse is still out), press the foot switch and bring the electrodes together, without work metal between them. There should not be any current flow. If current does

\* See page 18, second footnote.

flow, see which ignitron is firing, making a blue light inside the tube; this can be seen through the anode glass seal on top, or sometimes through the igniter seal below. An ignitron that fires or passes current should be replaced, for it is probably gassy. See Sec. 4-19.

If both ignitrons seem all right, open the line switch, replace the panel fuse, reclose the line switch, turn on the water, and try a weld. Remember that the time length of weld is measured by some timer or other switch around the welder, which must be set for the right length of time. The ignitron contactor takes orders from this timing switch and will pass current as long as the timing switch is closed.

**4-9. No Current.**—If no current flows, check to see if the thermostat or flow switch has closed its contacts and that relay *CR* (in Fig. 3*G*) “picked up” or closed its contacts while the welder was trying to weld. Use a voltage tester or voltmeter to be sure that there is voltage across both ignitrons (from 1 to 3 in Fig. 3*G*), also across contact 5 while *CR* relay is open. When contact 5 is closed and ignitrons still do not fire, check to be sure there is voltage from starter terminal 7 to tube-*L* cathode 3 and from starter terminal 8 to tube-*R* cathode 1.

**4-10. Fuse Blows.**—If the igniter fuse blows, one or both of the ignitron tubes are not firing properly. The causes may be:

1. The load current is too low, less than 40 amperes. See Sec. 4-11.

2. A starter lead may not be connected to starter terminal.

3. There may be a short circuit from starter to cathode. This short may be in the copper oxide rectifier. See Sec. 4-13.

4. The ignitrons are too hot, either from overload or from not enough cooling water.

5. An ignitron tube may be hard-starting and may need to be replaced. See Sec. 4-16.

Do not put any fuse larger than recommended by the manufacturer in this ignitron contactor panel unless you are willing to gamble on damaging the rectifiers and the ignitron tubes.

If only one of the ignitron tubes passes current, the welder transformer will probably make more noise than usual, because it has become saturated by the current of just one tube. This causes the welder to draw more current than usual, which may open the line breaker or blow a fuse in the line switch.



**4-11. Too Small Current Load.**—Ignitron tubes are expected to carry large currents, and they refuse to work on very small currents. Ignitrons must never be used to carry load current less than 40 amperes, because this greatly shortens the life of the tube. Such small currents are often drawn by small welders, and most flash welders. Any welders, large or small, may draw less than 40 amperes if the ignitrons can fire when the electrodes are not closed onto the work. This often happens on welders that have many electrodes (hydromatic welders) when all these electrodes are not being used. This low current may also be caused by welding steel with scale on it. Whenever the load can be less than 40 amperes, by actual measurement with a pointer-stop ammeter,<sup>6-1\*</sup> this load must be increased by adding a "dummy load." This is a resistor purchased separately and connected across the welder transformer so as to draw additional current of about 25 amperes. (Sometimes, especially with flash welders, these resistors must be made to draw at least 50 amperes.) For this purpose about 9 ohms resistance is used at 220 volts, or 18 ohms at 440 volts. Since current flows in this resistor whenever the ignitrons pass current, the resistor must be large enough to carry this 25 amperes during all the time the tubes will have to work.

If the contact, which closes the starter circuit, should accidentally stay closed until the electrodes have separated, the weld will be burned and the ignitrons will still be passing current into the welder transformer. Since this current is probably less than 40 amperes, the tubes and the rectifiers are also being damaged.

**4-12. Copper Oxide Rectifier.**—As mentioned in Sec. 3-7, copper oxide rectifiers are used to let current pass one way through the tube igniters, but prevent current from passing in the opposite direction, which would damage the igniters. A copper oxide rectifier, also called a Rectox, is made of many circles or disks of copper. Before these are stacked together as shown in Fig. 4B, one side of each copper disk is made rusty (covered with copper oxide) while the other side is clean copper. Electric current can flow easily from the copper oxide into the

\* Small numbers used throughout the book refer to other sections where further information will be found. Here it is suggested the reader see Sec. 6-4 of Chap. 6.

copper, but something in each disk will not let the current flow the other way, from the copper to the copper oxide. The direction in which the current will flow through a stack of disks depends upon which way they are piled together. Many disks are used together to handle the voltage or current. Larger disks or fins are placed among the copper disks to help any heat to get out of the disks, and to make connections.

The copper oxide rectifier or Rectox used on most ignitron contactors (see Fig. 4B) really includes two separate rectifier units, with connections at *A*, *B*, *C*, *D* and *E*. One rectifier unit is from *A* to *C*; the other is between *C* and *E*. The small arrows show which way the current flows in each disk. Current can flow from *B* to *A* and from *B* to *C*; also from *C* to *D* and from

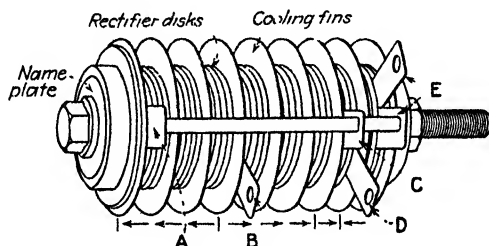

FIG. 4B—Copper oxide rectifier used in ignitron contactor

*E* to *D*. A wire on the rectifier connects *A*, *C* and *E* together, and is the common connection to these three terminals. This common connection goes to the control circuit (fuse, terminal board and flow switch). The *B* connection near the name-plate end of the rectifier goes to the ignitron support, connected to the line. The *D* connection, near the panel end of the rectifier, goes to the igniter or starter terminal.

**4-13. Testing the Rectifier.**—If part of a copper oxide rectifier shorts or is damaged, the entire rectifier should be replaced, since it is not practical to put new disks into a stack. To tell whether a rectifier is good or not, open the line switch, disconnect the starter of the ignitron tube from the starter terminal and measure the resistance of the rectifier with an ohmmeter.<sup>6-3</sup> Since the ohmmeter measures the resistance by passing a small direct current through it, you would expect that this d.c. could pass easily one way, between rectifier terminals such as from *B* to *A*, but not pass easily from *A* to *B*. This means that the

resistance measured from *A* to *B* should be much larger (at least four times as large) than when the ohmmeter leads are reversed to measure from *B* to *A*. If the ohmmeter shows that the resistance value measured from *A* to *B* is not greatly different from that when the ohmmeter leads are reversed, then the rectifier is probably shorted between *A* and *B*. Such measurements should be made between each pair of rectifier terminals. As a further check, compare the resistance measured between *A* and *B* with the resistance between *A* and *B* of another rectifier of the same kind. In the ignitron contactor, if the rectifier is shorted between *B* and *A* or *C*, control current passes through this part of the rectifier instead of going through the starter of the ignitron. Therefore the ignitron does not fire and the fuse blows.

**4-14. Current in Igniter or Starter.**—The circuit through the copper oxide rectifiers and fuse is not expected to carry current

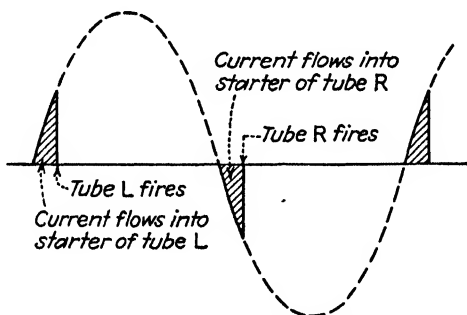

FIG. 4C.—Current flow in starters (as shown by oscilloscope).

all the time when the push button or *CR* relay contact 5 is closed. As mentioned in Sec. 3-9, this current is about 15 to 25 amperes, which would blow the 6-ampere fuse or damage the rectifiers unless this current stopped each time that the ignitron tube fired. This 15 amperes is forced through the fuse and starter circuit by the line voltage between 1 and 3 (Fig. 3D). However, the instant the ignitron passes current, the voltage between 1 and 3 decreases to 15 or 20 volts (arc drop),<sup>3-9</sup> which is not enough to force the current through the starter. In Fig. 4C the solid line shows how this starter current changes during each cycle when the ignitrons are working normally. But if both ignitrons fail to fire, the starter current follows the dotted line and flows during the entire cycle.

**4-15. The Oscilloscope.**—Of course, all this happens in less than  $\frac{1}{60}$  second, so that no ordinary meter can show this. There is a very handy meter called the *oscilloscope* which shows a picture like the solid line of Fig. 4C; this is the best way of knowing whether the ignitrons are working properly. Sometimes called just a "scope," this instrument is described in Sec. 6-7. It can be obtained through most radio supply stores. The scope can be adjusted to show just one cycle, as in Fig. 4C, or a number of these little firing current peaks, as in Fig. 4D (where four cycles appear at once). But notice now that, although the first up-and-down current peaks are normal, several of the other upward peaks are much larger than usual. Such large peaks, appearing even only once in a while, show that one ignitron is having trouble. Even though that ignitron is firing every cycle and the blue light inside it seems as bright as in the other ignitron, still the scope shows that it is becoming hard for this ignitron to start. We say it becomes "hard-starting."

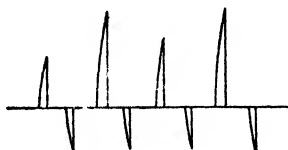

FIG. 4D.—Igniter current peaks, showing a "hard-starting" ignitron

**4-16. "Hard Starting" of Ignitrons.**—The "hard-starting" ignitron is not unusual, for any ignitron may become "hard-starting" as it nears the end of its useful life. If you have not been watching it with a scope, the first thing you know is that the 6-ampere starter fuse blows. With a new fuse it may work many more days before blowing another fuse. When the tube has blown several fuses or you are satisfied that the fuse was not blown by some other cause, a spare ignitron tube should be made ready. Hard starting usually becomes gradually worse. It may be caused by overload on the ignitron, too warm water, or loads less than 40 amperes. Whenever the starter fuse blows, it gives notice that an ignitron soon may need to be replaced, but it also gives one a chance to check the load conditions and prevent early death of the ignitron.

**4-17. Which Ignitron Blew the Fuse?**—In the ignitron contactor, one fuse protects both starters, so either ignitron can make that one fuse blow. Without instruments handy, about all you can do quickly is replace the fuse and look down into the ignitrons while the next weld is made. You may see that only

tube *R* shows blue light, which means that tube *R* is all right but that tube *L* did not fire. You may not be lucky enough to have tube *L* fail to fire again while you watch it, for it may wait until your back is turned. Here a scope or an analyzer may save a lot of time.

**4-18. Igniter Resistance.**—When the ignitron tube is hard-starting, this condition usually causes a change in the resistance of the igniter or starter. If you measure this igniter resistance with an ohmmeter,<sup>6</sup> you can learn much about the condition of the tube. However, the correct resistance is measured only when the tube has been given at least half an hour to cool down to room or water temperature. The igniter material changes its resistance, having less resistance when it is warmer. With the line switch open, this igniter resistance is measured by placing one ohmmeter lead on the starter or igniter connection of the tube and the other lead on the cathode or bottom connection.\* This must be done while the tube is in its usual upright position so that the igniter is dipping the usual distance into the mercury pool inside the tube. Good ignitron tubes may show igniter resistance values anywhere between 5 and 500 ohms, but more often only between 10 and 150 ohms. To know whether an ignitron tube is getting worse, you not only need to know its igniter resistance now but also its igniter resistance when it was new. If the igniter resistance is getting less from week to week, be sure the ignitron is not being overloaded or punished in some way. When the value is less than 5 or 10 ohms, the ignitron has probably failed completely, and it may have injured the copper oxide rectifiers also.

**4-19. Gassy Tubes.**—If a tube passes current when it should not, it may be *gassy*. This means that air has leaked into the tube, forming a gas mixture that will let current pass whenever there is voltage across the tube. To check† such a tube in an

\* More nearly correct resistance readings are obtained if the ohmmeter leads are then reversed, and the average of the two readings is used.

† A further check for a gassy ignitron can be made with a high-voltage induction spark coil. To test the tube, disconnect the anode cable terminal from the bus and bend it so that it almost touches the ignitron cylinder wall. If the spark coil can make a  $\frac{1}{2}$ - or  $\frac{3}{4}$ -inch spark, hold the anode terminal about 1 inch from the cylinder. Touch the spark-coil tip to the anode cable. There should be no sparks or pink or orange glow inside the tube for more than a few seconds. Next, press the spark-coil tip against

ignitron contactor, open the line switch, remove the 6-ampere fuse and reclose the line switch. If the tube still passes current, replace it with a good tube.

**4-20. Grounded Circuits.**—Much trouble comes from circuits that become grounded, where there is current flow from the electrical circuit into the welder frame, water pipe or other grounded parts. Such grounds will damage the copper oxide rectifiers used in ignitron contactors. Two ground connections are usually needed to cause trouble, but the grounds can be anywhere in the plant as long as they are on the same electrical system. The ground may not be there when the equipment is not being used. For example, a welding transformer had internal ground connections only when welding current was flowing in the winding, but tested clear of ground when the line switch was open. The flow of welding current caused the welder coils to move, making the connection to ground for only that instant. Welder transformers and other electrical equipment may test clear of grounds when first placed in service, and yet they will pass ground current when the windings get wet from condensing moisture in the wet air. To prevent such grounds, transformers should be frequently dipped in insulating varnish and baked.

**4-21. Maintaining Ignitron Equipment.**—What should be done to keep this tube equipment running smoothly, to get the best life from the tubes? Various plants using hundreds of ignitrons do certain things that can be followed as a guide. Such plants enjoy tube life of more than 3 or 4 years—well worth a little extra care. Some suggestions are given below.

**4-22. Tube Records.**—Keep tube records, a separate card or paper for each tube, showing the date received, date placed in service, and date moved to a new job. To help keep such records straight, some plants attach a record sheet inside each welder control, listing the tubes used (by tube type and serial number). When a tube is changed, the record is changed right at the job, instead of back in the office.

---

the anode lead so as to decrease the space between the anode terminal and the tube cylinder. Before this space decreases to  $\frac{3}{16}$  inch, a spark should jump across the gap. However, if there is a spark or glow inside the tube while the anode terminal is as much as  $\frac{1}{2}$  inch away from the tube cylinder, the tube is gassy and should be replaced.

**4-23. Watch Igniter Resistance.**—Check the igniter resistance of each tube every few weeks and keep a record of these numbers. Usually this resistance will not change much from month to month. Any great change in resistance will warn you of bad operating conditions and give notice when any tube is nearly through. Where several pairs of ignitrons are used in one place, better service may result if you place together tubes that have nearly the same igniter resistance. In some cases, a new tube and an old tube may not work together so well as two old tubes.

Where ignitrons are being used on either 220 or 440 volts in the same plant, remember that an ignitron that blows fuses on 220 volts may still give service in 440-volt equipment.

**4-24. Clean Tubes.**—Keep ignitron tubes clean and watch them for water leaks or rusting. (This applies mainly to older tubes which do not have stainless-steel water jackets.) A coat of Glyptal paint will help most metal tubes. Many water leaks may be soldered shut. Never let water drip onto an ignitron, especially when it is working. Keep the hollow opening clean around the anode glass seal in the top of the tube. Remember that full line voltage is there, ready to jump from the copper wire above the glass, over to any other part of the ignitron, including all the outside steel walls. Flush out the ignitrons occasionally, applying low water pressure to the upper water connection or outlet so that the water reverses its usual direction.

**4-25. Measuring Loads.**—Measure the heavy load conditions on each pair of ignitrons to be sure they are not overloaded. Also be sure that there is no possibility of working at less than 40 amperes load. Whenever a welder is moved or used on a new job, be sure to check the new load conditions during the first welds. One minute later may be two tubes later. The right load for ignitron tubes is so important that Chap. 5 will cover it. To know whether the load is right, you must be able to measure it in the right way. Ordinary ammeters cannot follow the sudden current changes in a welder. Chapter 6 will cover meters and measurements. But first it is necessary to learn what to measure and why.

**4-26. What is "Load"?**—What would you think of a plant electrical man who spent hours on a shut-down machine, checking all the starter and control circuits but failed to notice that the motor was hot, even smoking, and that the overload relays had

tripped? The same thoughts apply to a plant electrical man who spends hours checking and worrying about the control circuits of ignitron equipment that has stopped, yet does not bother to check to see if the ignitrons are overloaded. A motor will groan, will stall, will smell and will smoke when overloaded, but may carry overloads for many minutes before yelling for help. Overloaded ignitron tubes will make no noise. Since they never move, they cannot stall. They can get very hot, but you learn to keep your hands off them, even when they are cold, for they are still "hot" electrically. Worst of all, ignitrons can be ruined by just a few seconds of severe overload, and they do not return to life even long enough to let you measure the amount of the knockout current.

Do not let this make you feel that tubes are delicate or that tubes do not have a place in industry along with motors, cables or switchgear. Instead, remember that two small ignitrons will safely carry as much current as a 200-horsepower motor will carry, but, since these ignitrons are only as big as pop bottles, they cannot hope to carry this current for more than a few seconds at a time. For a second, a pair of large welder ignitrons can carry all the electric power needed by an average plant employing 500 men. Now you see why Chap. 5 will talk about seconds of time and thousands of amperes.



## CHAPTER 5

### THE RIGHT LOAD FOR IGNITRON TUBES—RATING

Each size of ignitron tube is built to carry a certain amount of load current. We must learn how large this current can be without hurting the tube. But first let us think about the load on a motor. We know that a motor can carry a certain load. Usually a 5-horsepower motor can carry a load of 5 horsepower steadily, hour after hour. This is the load that the motor is expected to carry and is the load for which the motor was designed and built. It is the rated load of the motor, and we say that the motor is *rated* 5 horsepower continuously. We also know that almost any 5-horsepower motor will carry double load, or 10-horsepower load, for a few minutes, but it will roast and fail if it tries to carry this 10-horsepower load for an hour. The motor name plate of this motor shows the 5-horsepower rating or rated load, but it does not show you how long the motor will carry the 10-horsepower load safely. You do not need to know this "10-horsepower short-time rating" because most motors are used to carry their loads hour after hour.

**5-1. Ignitron Rating.**—The ignitron tube is different. It also has a continuous load rating like a motor, but an ignitron is hardly ever expected to carry steady load. Instead, ignitrons are used with welders, which usually need current for only a part of each second. For example, a large ignitron may be able to carry only 400 amperes of current steadily. But we do not want to put a 400-ampere rating on this tube when we know that this tube will be used to carry 1000 amperes or 2000 amperes during very short welds. We shall want to know how long the ignitron can safely carry 600 amperes, or how long it can safely carry 1500 amperes, and many other amounts of current load. To show all these many load conditions, we use a tube rating curve or line, drawn in a chart like Fig. 5C, which is explained in Sec. 5-6. Each size of ignitron tube has a rating curve.

**5-2. Ignitron Sizes.**—Four different sizes of ignitron tube are used now in ignitron contactors. Each size of ignitron has a

type number, which is given by the company that makes the tube. Table I shows these four ignitron sizes, called Size A, B, C and D, and also shows the type numbers used by two large manufacturers of these tubes. Size A is the smallest of the four ignitron sizes, and size D is the largest. Table I shows that a Type WL-657 tube is a Size B tube, made by Westinghouse for use on 220-volt lines. The General Electric Type FG-271 is also a Size B ignitron. These two tubes have the same rating, and either type can be used to control a 220-volt welder that needs Size B ignitrons. In the same way, a pair of FG-235A ignitrons carrying a welder load at 440 volts could be replaced by a pair of WL-651 ignitrons, since both of these types are Size C tubes. The rating curve for a Size C tube, when working on 220-volt lines, is shown in Fig. 5C; on 440-volt lines, in Fig. 5D. The rating curves for sizes A, B, and D are shown on these same charts.

TABLE I.—IGNITRON TYPE NUMBERS

Size	Westinghouse		General Electric*
	220 volts	440 volts	220 or 440 volts
Size A.....	WL-686	WL-681	GI-415
Size B.....	WL-657	WL-652	FG-271
Size C.....	WL-656	WL-651	FG-235-A
Size D.....	WL-658	WL-655	FG-258-A
Superseded by Size A Above			
Size A.....	WL-659	WL-654	FG-402
Used for High-voltage Controls or High-voltage Rectifiers			
	WL-679		FG-259-B
	WL-653-A		FG-238-B

\* G.E. ignitron tubes usually require a series resistance in the igniter circuit, 1 ohm at 220 volts, 4 ohms at 440 or 550 volts.

**5-3. Reading a Chart.**—In order to show how to read useful figures from a chart, let us make a simple chart like Fig. 5A. This chart will show how much weight a man can lift. Suppose that a man lifts 50 pounds for 30 seconds, then rests for 30 seconds, and continues lifting and resting in this way for an hour. We

show this at the point marked *A* on the chart Fig. 5A. *A* is on the left-to-right line marked "50 pounds" and on the up-and-down line marked "30 seconds during each minute." Next suppose that this man can lift 100 pounds, but only for 15 seconds during each minute. This is shown at *B*, where the "100-pound" line crosses the "15-second" line. Now, if this man tries to hold some weight for an hour without ever resting, how much can he hold? He will have all he can do to hold 10 pounds, so put that at *C*, at "10 pounds" and "60 seconds during each minute (or continuous)." Finally, suppose the most he can lift at any time is 200 pounds. He may be able to lift this 200 pounds for 5 seconds during each minute, as shown at *D*. Now, if you

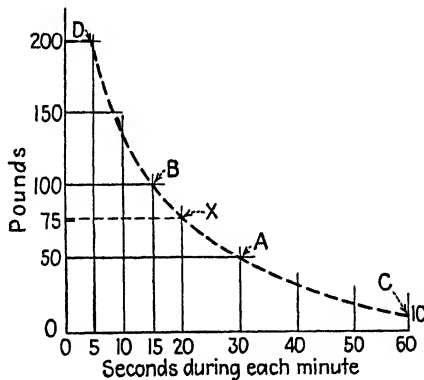

FIG. 5A.—Curve showing weight lifted by a man for various periods of time.

draw a smooth line through points *C*, *A*, *B* and *D*, you will have a curve, from which you can find other things, such as "How much load can the man lift for 20 seconds of each minute"? Follow the line marked "20 seconds" up until you come to this curve line. This is at the point marked *X*. Now follow the straight dotted line to the left, and you find that the answer is about 75 pounds. The curve does not go higher than *D*, showing that the man cannot lift more than 200 pounds even for an instant.

**5-4. Simple Tube Chart.**—In the same way we can draw Fig. 5B to show how much load a pair of Size B ignitrons can carry at 440 volts for any number of cycles during 1 second. (Use 60 cycles = 1 second.) Point *A* on Fig. 5B shows that

these tubes can safely carry 250 amperes for 30 cycles out of each second (of 60 cycles), because *A* is at the point where the 250-ampere line crosses the 30-cycle line. At *B* these tubes can carry 800 amperes for 6 cycles during each second. The curve goes no higher than *D*, and this shows that 1200 amperes is the largest current that these tubes should carry, even for an instant. How much can this pair of Size B tubes carry continuously? Look to the side of the chart where the tubes are carrying current for all 60 cycles during the second, and here point *C* shows the continuous rating is 130 amperes.

**5-5. Lines on the Chart.**—Figure 5*B* has the same space between all the up-and-down, or vertical, lines and also between

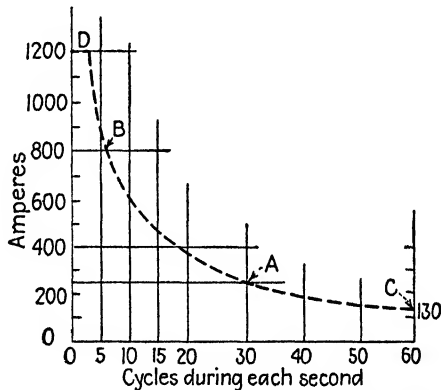

FIG. 5*B*.—One kind of load chart for Size B ignitrons.

all the left-to-right, or horizontal, lines. This makes it easier to find any number of amperes or cycles you want. But notice that the curve between *B* and *D* is very steep, while it is very flat between *A* and *C*. It is hard to tell just where the steep and flat parts of the curve cross the other lines of the chart. Also, if we wanted to show the rating curve of big Size D ignitrons on this same chart of Fig. 5*B*, the curve would run off the top of the page, for the curve would have to reach up to 5000 amperes. Therefore, to make a complete chart we must use a different scale, by changing the size of the spaces between lines.

**5-6. Logarithmic Scale.**—The charts of Figs. 5*C* and 5*D* show the present ratings of all four sizes of ignitron tube. The scale used in these tube rating charts is called the *logarithmic scale*.

Notice that the space between the 100- and 200-ampere lines is not the same as the space between the 200- and 300-ampere lines or between the 500- and 600-ampere lines. Instead, the space between 100 and 200 is the same as the space between 1000 and 2000, or between 400 and 800. As a result, the bottom half of the chart includes the current values from 100 to 1000 amperes, while the upper half includes currents from 1000 to 10000 amperes.

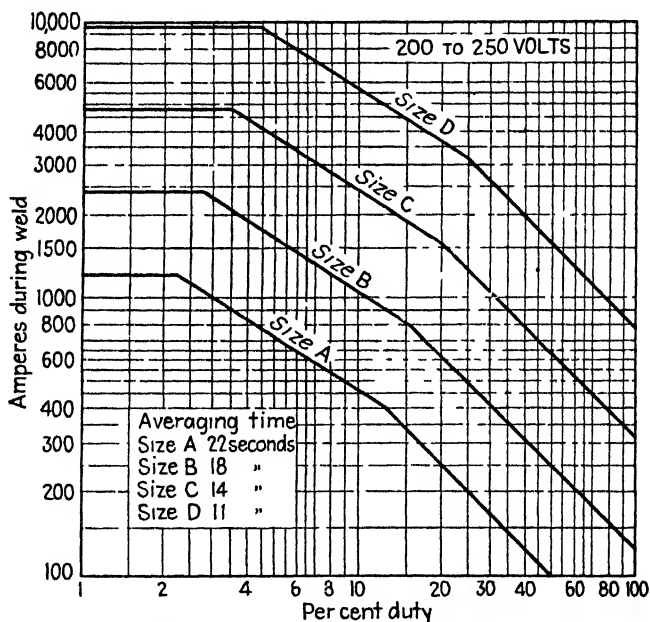

Fig. 5C.—Rating curves of ignitron tubes (pair) at 230 volts.

At the sides of Figs. 5C and 5D, the numbers show “amperes during weld.” On rating curves supplied by tube manufacturers, this same scale is sometimes called “demand current—amperes rms.” “Demand current” shows that this is the current demanded by the welder while the weld is being made, and is therefore the same as “amperes during weld.” “Amperes rms” means “root-mean-squared amperes,” which is the technical name for effective current, such as is shown by an ammeter, in contrast to “crest amperes” or “peak current” indicated by the height of the a-c wave shown by an oscilloscope.

Along the bottom of the charts, the number of cycles is not used as it was in Fig. 5B. Instead the "Per cent duty" is shown. To explain this quickly, tubes that pass current for 10 cycles out of every 100 cycles are working at one-tenth duty or 10 per cent duty. Working 6 cycles during every 60 cycles is also 10 per cent duty. Working 30 cycles during each 60-cycle second, is working half the time, or 50 per cent duty. Tubes working steadily, without resting, are working at 100 per cent duty, and

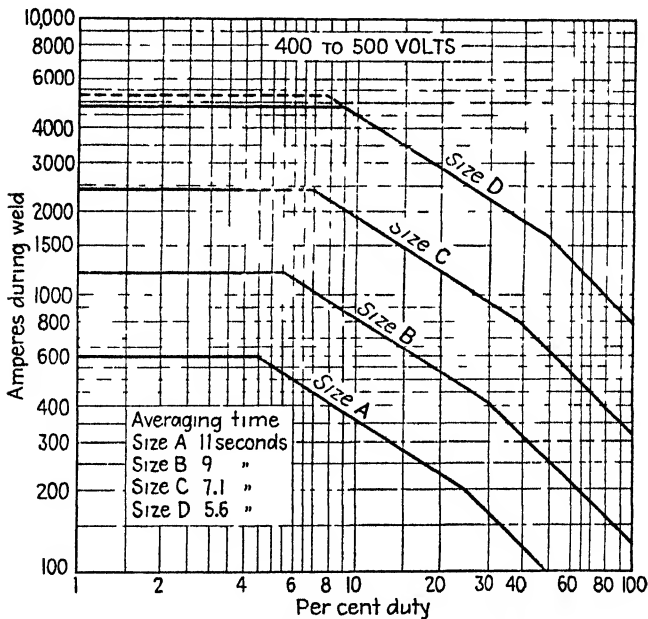

FIG. 5D —Rating curves of ignitron tubes (pair) at 460 volts.

such continuous ratings are shown at the right side of the chart. Each slanting line shows the rating of one of the four sizes of ignitron tube when the tubes are used in pairs. In Fig. 5C, the 40 per cent duty line and the Size C line cross at about 800 amperes. This shows that 800 amperes is the load carried by two Size C tubes at 40 per cent duty, and not the load carried by one tube alone. At 100 per cent duty (at the right-hand side of the chart), a pair of Size B ignitrons can carry 130 amperes continuously. A steady load of 800 amperes can be carried by a pair of Size D tubes.

**5-7. Ampere Ratings for Ignitron Contactors.**—Since ignitron contactors are being used for welders in the same way that magnetic contactors are used, it is quite natural that many people should think that ignitron contactors have standard ampere ratings as magnetic contactors have, such as a 150-ampere contactor or a 600-ampere contactor. But the current rating of an ignitron contactor is merely the rating of the ignitron tubes that are used in the contactor. Yet, by using ignitrons on various jobs, we have learned that Size A ignitrons will handle a welder that usually needs a 150-ampere magnetic contactor, and that a 300-ampere magnetic contactor can be replaced by Size B ignitrons. In making this comparison, we observe that most welders draw current for less than one-third of the time, so the contactors pass current for less than 20 cycles during each second. This is about 30 per cent duty. When we look to see where the slanting lines cross the 30 per cent duty line of Fig. 5C or Fig. 5D, we find that Size A tubes are rated 160 amperes, Size B tubes are rated 400 amperes, Size C tubes are rated about 1000 amperes, and Size D tubes are rated more than 2000 amperes. As a result of this, when anyone speaks of a 150-ampere tube contactor, it is assumed that he means Size A tubes. Similarly, a 300-ampere contactor calls for Size B tubes; a 600- or 900-ampere contactor calls for Size C tubes; a 1200-ampere contactor takes Size D tubes. These are not actual ratings, but they are being used for convenience.

**5-8. Per Cent Duty.**—Instead of saying "What is the per cent duty of the tube?" we can say "What per cent of the time are the tubes on duty?" or "What part of the time do the tubes work?" To explain this better, let us figure what part of the time a man works, or find a man's "per cent duty." If a man works 8 hours a day, he is on duty 8 hours out of 24 hours, or he works  $\frac{8}{24}$  or  $\frac{1}{3}$  of the time. He is on the job 8 hours; he is off 16 hours. His per cent duty each day is  $\frac{8}{24} \times 100$ , or  $33\frac{1}{3}$  per cent duty. During a whole week his per cent duty is

$$\frac{\text{Total hours worked during one week}}{\text{All the hours there are in a week}} \times 100$$

If he works 5 days, or 40 hours, each week, his per cent duty is

$$\frac{8 \text{ hours} \times 5 \text{ (days)}}{24 \text{ hours} \times 7 \text{ (days)}} \times 100 = \frac{40}{168} \times 100 = 24 \text{ per cent}$$

He is working 24 per cent of the time during a week.

In the same way, if an ignitron contactor passes current into a welder for 8 cycles during each 24 cycles, the ignitrons are working at about 33 per cent duty. If the welder makes a number of spot welds, each 8 cycles long, and there are 16 cycles of "off" time (when no current passes) between the end of one weld and the start of the next weld, the ignitrons are working 8 cycles out of 24 cycles (not 8 out of 16). At this rate, how many welds will be made in 2 seconds? 2 seconds =  $2 \times 60$  cycles = 120 cycles. The welder is working at the rate of one weld every 24 cycles. So, in 120 cycles of time there will be  $120/24 = 5$  welds.

If a 440-volt welder takes 600 amperes of current for a weld 8 cycles long and makes 5 welds every 2 seconds, what size of ignitron is needed to control this welder? The time for each weld must be  $\frac{2 \text{ seconds}}{5} = \frac{120 \text{ cycles}}{5} = 24$  cycles. Since the length of current flow for the weld is 8 cycles, the per cent duty is

$$\frac{\text{Current "on" time}}{\text{Total time}} = \frac{8 \text{ cycles}}{24 \text{ cycles}} = 33 \text{ per cent duty}$$

On Fig. 5D, we find that the 600-ampere line crosses the 33 per cent duty line at a point that is above the slanting Size B line, but is below the Size C line. This load is therefore too much for Size B ignitrons, but Size C ignitrons will carry it easily. Complete calculations of per cent duty are given in Secs. 5-13 to 5-16.

**5-9. How Welder Kva Affects Choice of Ignitrons.**—So far we have said the ignitrons carried a load of current in amperes. This load can also be given in kva.<sup>2-15</sup> In welding service, the kva load of the welder may be used in choosing the size of the ignitron tubes. However, do not use the kva rating of the welding transformer, because the tubes must often carry loads two to four times this transformer rated kva. The largest kva load drawn by the welder may be used in Table II to choose the tube size.



TABLE II.—LARGEST KVA DEMAND FOR SELECTING IGNITRON TUBES

Supply, volts	Per cent duty (during tube averaging time)						Ignitron tube size, using 2 tubes	Welder* rating, kva
	2%	5%	10%	25%	50%	75%		
220	264	156	101	44	22	14	A	20
	528	374	242	108	55	35	B	50
	1056	836	548	275	132	88	C	125
	2112	1958	1255	726	328	220	D	300
440	264	242	158	88	41	28	A	40
	528	528	361	202	110	73	B	100
	1056	1056	836	475	268	176	C	250
	2112	2112	1976	1100	691	440	D	675

\* These welder kva ratings are given only as a guide to show the welders that can usually be controlled by various ignitron tubes. In general welding service, these tubes and transformer sizes are well matched. These sizes of transformer can overload the tubes shown next to them under conditions mentioned in Sec. 5-15.

Welder transformers are rated at 50 per cent duty since they are not required to work continuously. A 100-kva welder transformer is designed to carry 100-kva load just half the time.

**5-10. How to Measure Load.**—The only way really to know the load of a welder is to measure its current and voltage separately and calculate  $\frac{\text{amperes} \times \text{volts}}{1000} = \text{kva}$ . However, ordinary meters do not work fast enough to measure the real load during a short weld. Therefore pointer-stop meters or oscilloscopes are recommended, as described in Chap. 6. The load may also be measured (within about 10 per cent accuracy) with an ordinary ammeter and voltmeter if the load current is held on for a second or two to let the meter pointers reach a steady reading. To prevent burning the electrodes during such a test, they may be shorted onto a bar of copper.

**5-11. Required Cooling Water.**—To carry safely the load shown in Fig. 5C or 5D, the ignitron tubes must be cooled by water of the amount and temperature given by the tube manufacturer. Ignitrons will be damaged by not enough cooling water. Sizes A, B and C usually require at least  $1\frac{1}{2}$  gallons of water per minute through each pair of tubes.<sup>4-5</sup> A pair of Size D tubes requires at least 3 gallons of water per minute. Ignitrons will be damaged if water is allowed to freeze in them.

**5-12. Averaging Time.**—To find the right value of per cent duty to use above,<sup>5-8</sup> it is necessary to do all figuring within a certain number of seconds, called the *averaging time*. In Fig. 5C or 5D notice that for each size of tube the averaging time in seconds is given. This averaging time is less at 440 volts than it is at 220 volts. Averaging time is the longest time during which it is safe to average the time of current flow and of no load. To learn the reason for this averaging time, let us see how averaging time applies to a 10-horsepower motor that can carry 10-horsepower load all day. That motor can also probably carry 20-horsepower load for 1 minute during each 4 minutes,\* if it carries no load during the other 3 minutes. Working one minute in four, it is operating at 25 per cent duty. If that motor tries to carry 20-horsepower load for one day, and then rests for three days at no load, the duty is still 25 per cent, but the motor probably roasts and fails during the first hour or two. The motor cannot carry this overload for 25 per cent of the day, but it can carry the overload for 25 per cent of some shorter time, such as 2 hours. This 2 hours is called the *averaging time* of the motor, since this is the longest time during which it is safe to average the period of overload and no load. The overload produces extra heat, which is stored in the motor body until this heat can be removed during the no-load period. But if the overload lasts too long, the motor temperature is raised too high by the stored heat. In the same way, the ignitron tubes are operated at overloads followed by periods of no load. The heat produced by the overload must be stored in the materials of the tube until it can be removed during no load periods. The large overload current passing through the tube produces heat so quickly that the tube can store up this heat for only a few seconds before the tube may be damaged. Figures 5C and 5D show the present

\* The heat produced by current passing through a motor or a cable increases as the square of the current, so that doubling the load current increases the heat four times. However, the curves near the right-hand side of Figs. 5C and 5D show that the heat produced by current passing through an ignitron tube increases only in direct proportion to the current. Most ignitrons can carry twice as much current at 50 per cent duty as they can carry continuously. This difference results because the resistance of a motor or cable remains nearly constant, while the resistance of the arc in a tube decreases as the current increases, so as to maintain constant arc drop.<sup>3-9</sup> ( $IR$  is constant, so  $I^2R$  changes in proportion to  $I$ , not  $I^2$ .)

values of averaging time for each size of ignitron. In figuring the load and size of ignitrons from tube-rating curves like Fig. 5C or 5D, the per cent duty of the load must be figured on the most severe conditions that will occur during this short averaging time.

**5-13. Complete Calculations of Per Cent Duty.**—Including the averaging time, we can now calculate the right value of per cent duty to use with the tube-rating curves of Figs. 5C and 5D, as we did in Sec. 5-8. Let us start with an easy one. If tubes pass current for 1 second and then pass no current for 1 second, we say that they are 1 second "on," 1 second "off." On a 220-volt line, suppose Size B ignitrons are 1 second "on" and 1 second "off," repeating during a total of 20 seconds, and then rest 40 seconds before starting all over again. What is the per cent duty? The first step is to find the averaging time for these Size B tubes at 220 volts. Figure 5C shows it is 18 seconds. Next find the heaviest load condition during any 18 seconds. This heaviest load is during the 20 seconds when the tubes are working. Since the 18-second averaging time is finished before the start of the 40-second rest time, do not include any of this 40-second rest time. During the 18-second averaging time, these tubes are "on" a total of 9 seconds and "off" a total of 9 seconds. Since the tubes pass current for 9 seconds out of 18 seconds, the per cent duty is  $\frac{9}{18} \times 100 = 50$  per cent.

If Size B ignitrons at 440 volts pass current steadily for 5 seconds "on" and then are "off" for 45 seconds, you might make the mistake of saying that these tubes worked 5 seconds during 50 seconds, and that this is 10 per cent duty ( $\frac{5}{50} \times 100 = 10$ ). Instead, remember the first step—find the averaging time from Fig. 5D. It is 9 seconds. Forget all the time except the 9 seconds during which the heaviest load occurs. During these 9 seconds the tubes are "on" for 5 seconds. The correct duty is therefore  $\frac{5}{9} \times 100 =$  about 56 per cent. So far, time in seconds has been used. If these Size B tubes are passing current to a 440-volt welder, which makes 30 welds during these 9 seconds, and each weld is 10 cycles long, then the total "on" time is 10 cycles  $\times$  30 = 300 cycles. The duty during this 9-second time is

$$\frac{10 \text{ cycles} \times 30}{60 \text{ cycles} \times 9} \times 100 = \frac{300}{540} \times 100 = \text{about } 56 \text{ per cent}$$

This is the same answer as before, because the total time of these thirty 10-cycle welds is 300 cycles, or 5 seconds, the same as before.

**5-14. Formula for Per Cent Duty.**—The formula or general rule is:

Per cent duty

$$= \frac{\text{Total of all "on" time, within the averaging time}}{\text{Total averaging time in cycles}} \times 100$$

To work with this formula, use, for example, a 440-volt welder that puts eight spot welds on one steel frame in 2 seconds and makes five of these frames in a minute. Each spot weld draws

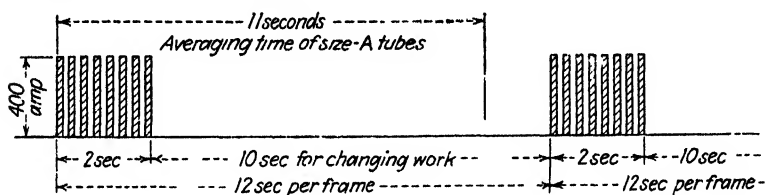

FIG. 5E Picture of welder operation, to find per cent duty

400 amperes for 5 cycles of time. Size A tubes are used. What is the per cent duty, and are these tubes overloaded?

It is best to draw a picture to show a duty like this, and Fig. 5E is the picture. Since 5 frames are made in 1 minute, there is a total of  $\frac{60 \text{ seconds}}{5} = 12$  seconds for welding one frame. The

spot welds are made during 2 seconds, so this leaves 10 seconds for the operator to change work. Figure 5D shows 11 seconds averaging time for Size A tubes at 440 volts. Figure 5E shows that only one frame is welded during any 11 seconds. So within the 11 seconds averaging time there will be only the 8 spot welds of 5 cycles each, to make one frame. Using the formula above,

$$\begin{aligned} \text{Per cent duty} &= \frac{5 \text{ cycles} \times 8 \text{ (spots)}}{60 \text{ cycles} \times 11 \text{ (seconds)}} \times 100 = \frac{40}{660} \times 100 \\ &= \text{about 6 per cent} \end{aligned}$$

In Fig. 5D, following up the 6 per cent duty line, we find that the Size A tubes are rated to carry 500 amperes load. Since the current drawn by the welder is only 400 amperes, these Size A ignitrons are not overloaded.

**5-15. Overloaded Tubes.**—Let us see how tubes become overloaded because someone did not use the right averaging time. Suppose the spot welder above, was expected to make 300 frames in an hour, and the ignitron tubes were selected to give this production, averaged over an hour. Since 300 frames per hour is 5 frames per minute, this is exactly the speed at which the welder worked in the example above, as shown in Fig. 5E. At that speed, the tubes are not overloaded. It is well known that, in order to produce 300 frames an hour, the operator must weld 6 or 7 frames per minute for part of the time to make up for occasional lost time or moving stock. This faster operation never bothers the welder transformer or other parts that can

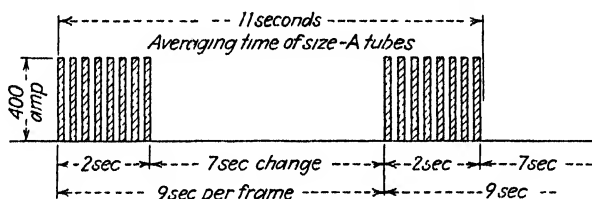

FIG. 5F Welder operation overloading ignitrons

carry overloads for many minutes. However, see what happens to the tubes. Figure 5F shows this same welder producing nearly 7 frames per minute. The operator is breezing along, taking only 7 seconds to change work. Within the 11 seconds averaging time, there are now two welds being made instead of one. The per cent duty becomes

$$\frac{5 \text{ cycles} \times 8 \text{ (spots)} \times 2}{60 \text{ cycles} \times 11 \text{ (seconds)}} = \text{about 12 per cent.}$$

At 12 per cent duty on Fig. 5D, the Size A tubes are shown to be rated about 330 amperes. They are being overloaded and should be replaced by Size B tubes in order to prevent damage and to obtain normal tube life. The welder is producing only the 300 frames expected, averaged over an hour's time, but the tubes are frequently carrying severe overloads. Ignitrons should be selected large enough to handle the load at the greatest speed that the welder will reach during any minute or less.

**5-16. Correct Tube Averaging Time.**—In all the examples above, the size of ignitron was mentioned, so the averaging time

was also fixed. Where the load conditions have been measured and the right size of ignitron is yet to be found, try one or more sizes. For example, suppose a larger 440-volt welder is making spot welds at the speed shown in Fig. 5*F*, but the measured current during weld is 1800 amperes. A glance at Fig. 5*D* quickly shows that Size A or Size B tubes are far too small. If you try Size D ignitrons first, with 5.6 seconds averaging time, the per cent duty is  $\frac{5 \text{ cycles} \times 8}{60 \text{ cycles} \times 5.6} = \frac{40}{336} =$  about 12 per cent.

When this 12 per cent duty is used in Fig. 5*D*, the load of 1800 amperes is well under the Size D curve, but it appears to be just above the curve for the Size C tubes, so that size C tubes seem to be too small. But just a minute! Your 12 per cent duty applies to Size D tubes, and not to Size C tubes. Figure again, using the right averaging time (7.1 seconds) for Size C tubes, and the per cent duty equals  $\frac{5 \text{ cycles} \times 8}{60 \text{ cycles} \times 7.1} = \frac{40}{426} = 9.4$  per cent. At this lower per cent duty, Fig. 5*D* shows that 1800 amperes load is under the curve for Size C tubes. Size C tubes may be used.

**5-17. Larger Tubes Are Better.**—Many large users of tubes are learning by experience that it is worth while to use ignitrons somewhat larger than indicated by the rating curves. As with other electrical equipment, conservative practice may give tube life far beyond the usual one-year warranty, to which the rating curves apply.

**5-18. Very Large Loads or Steady Loads.**—When a welder is so large that its current load is greater than the rating of Size D ignitrons, it is natural to think of using two pairs of ignitrons to carry the load. Several pairs of ignitrons can be used, but they do not divide the load between them. The practical arrangement is to let one pair carry the whole load, but for a shorter length of time, and then let the next pair of ignitrons take over the whole load for a while, letting the first pair rest. In this way, the per cent duty of each pair of tubes can be brought within the tube rating. For example, a large machine may draw 2000 amperes for 15 seconds or 15 minutes. Such times are longer than the averaging time of the largest ignitrons, so one pair of tubes alone is working at 100 per cent duty on such a load. Since Size D tubes are rated only 800 amperes at 100 per cent duty, it

becomes necessary to use four pairs of Size D tubes to handle this load. Each pair carries the whole 2000-ampere load for about 1 or 2 seconds and then enjoys 4 seconds rest while the other pairs of tubes carry the load. Timing relays<sup>7-1</sup> are used to switch the load between pairs of tubes. Each pair operates at 25 per cent duty under this plan. However, this arrangement cannot be used to carry current loads larger than the flat parts of the rating curves of Fig. 5C or 5D.\*

**5-19. Below 200 Volts or above 500 Volts.**—Ignitrons are not used at less than 200 volts because the igniters will not fire the tubes well at lower voltages. Some ignitrons may work even at 110 volts, but shorter life may result.

Ignitrons work well at higher voltages, but at reduced current ratings. The tubes need special mounting for safe operation at these higher voltages.<sup>25-4</sup> Table I on page 37 shows ignitron tubes that are sometimes needed at higher voltages.

**5-20. Tube Life and Warranty.**—With proper use and care,<sup>4-21</sup> tube life is often 3 years. The makers of ignitrons usually give a 12-month warranty. An ignitron that fails within 12 months after first being placed in service is usually returned for credit. If the tube served 3 months, credit up to 75 per cent is obtainable; after 9 months' service, only 25 per cent credit is obtainable. Naturally, tubes damaged by overload or rough handling receive no credit. A damaged tube usually cannot be repaired. Tubes may be kept in stock 6 months, but after that time the 12-month warranty begins to be used, whether the tubes are in service or not.

Since we have seen how ignitrons are rated in amperes of current and in per cent duty, we are now ready to measure these currents and times.

\* Ignitrons may be used to divide large current loads if reactors are added in their anode circuits.

## CHAPTER 6

### INSTRUMENTS FOR CHECKING TUBE CONTROLS

The study of welder loads and ignitron tubes in the previous chapters shows that good meters or instruments are needed to help service such welder equipment. To show what happens during short welds, these meters must be able to respond much faster than most ordinary meters. The meters and instruments that are needed for checking ignitron contactors are the same ones that are used for checking other sensitive tube controls described in later chapters. An analyzer and an oscilloscope are most necessary, as will be shown below. Many small plants have run for years without any meter to check electrical circuits. Some maintenance men have only a simple voltage tester to help them in their daily fight to keep production going. This is a shame. Plant managers are learning that much of their machine down time can be prevented by getting several good instruments for use by their electrical men. These instruments must be obtained for use with ignitron contactors and other tube control. But first let us mention a device so simple that it should be used by electrical men everywhere.

**6-1. Bell Ringer.**—The bell ringer is not an instrument, but a very simple device to check circuits and electrical connections. It is merely a doorbell and two dry cells connected in series with a couple of test leads. When the leads are touched together, the bell rings. When one lead is placed against one end of the wire and the other lead is placed against the other end of the wire, if the bell rings, the circuit is complete. If the bell does not ring, the wire is broken somewhere or the two ends do not belong to the same wire. Very simple, but very effective. Hundreds of troubles with tube controls have been cured by “experts” who used only a bell ringer to show wrong connections or broken circuits. The bell ringer is used only when all other electricity has been removed.



**6-2. Voltmeter.**—A very important instrument is a good voltmeter, to measure accurately the voltage (electrical pressure). Since a voltmeter is included in an analyzer, get an analyzer<sup>6-3</sup> instead. If a separate a-c voltmeter is purchased, it should include scales reading from 150 to 500 volts and must be accurate within 2 per cent of these full scales. It should draw very little current to operate it, and this is especially important if the voltmeter is also to be used for measuring voltages less than 30 volts. Rectifier-type voltmeters are less suited to tube circuits, since they are subject to wave-shape errors. An ordinary voltmeter cannot follow a drop in voltage during a short weld, for the moving pointer cannot respond fast enough. The oscilloscope<sup>6-7</sup> can

be used to show such voltage dips. There are also special voltmeters built with a pointer stop, similar to the pointer-stop ammeter.<sup>6-4</sup>

**6-3. Analyzer and Ohmmeter.**—

A combination instrument called the *analyzer* (also Unimeter, as in Fig. 6A, and other trade names) is the best all-round meter for checking tube equipment. Luckily, its cost is below \$35.\* Such an instrument includes a d-c voltmeter, a-c voltmeter, d-c milliammeter and ohmmeter. Three or four scale

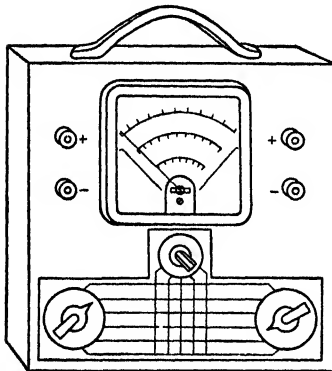

Fig. 6A.—Analyzer, or Unimeter

ranges are provided. For example, the a-c voltmeter† may have full-scale markings of 900 volts, 300 volts, 75 volts and 15 volts, and the desired range is obtained by moving a selector switch. The high ranges are for line and special control voltages, while the 15-volt scale is used for tube-filament voltages and welding-transformer secondary voltages. To give best results on tube controls, the voltmeter part of the analyzer should have high resistance (at least 1000 ohms per volt). The ohmmeter part is used for checking all resistors, also the resistance of tube igniters,<sup>4-18</sup> and copper

\* A less expensive kind is quite satisfactory, since a highly accurate instrument is not needed for most "trouble shooting." The analyzer has many operating ranges and is quite likely to be damaged if the operator forgets to keep the selector switch in the right position.

† Some analyzers include rectifier-type voltmeters and may give incorrect readings in phase-shifted circuits.<sup>19-3</sup>

oxide rectifiers.<sup>4-13</sup> Some analyzers also check capacitors.<sup>7-12</sup> There may also be a Db scale (decibels gain) for radio checking, for which an analyzer is often used. Most analyzers require a small battery inside, to operate the ohmmeter and other parts.

**6-4. Pointer-stop Ammeter.**—Having pointed out that it is necessary to know when ignitrons are overloaded<sup>1-26</sup> and having shown how much current (amperes during weld) can be safely carried by ignitrons (Figs. 5C and 5D), we should find out what instruments will measure these currents. We mentioned<sup>5-10</sup> that ordinary meters are not fast enough to measure the current flowing during a short spot weld. The weld is finished before the pointer reaches its correct reading. When you hear a fire alarm, you may run to see the fire, but you may find that the fire is out before you get there. However, if you could know where the next fire was going to be, you could be there ahead of time. This idea will not get you to see a fire, but it does let the pointer of an ammeter be in the right position to show the true current flowing during a short weld. A pointer-stop ammeter works like any ammeter except that the pointer is not left at the bottom of the scale, where it might "miss the fire." Instead, a mechanical stop raises the pointer to some place higher on the scale and closer to where the pointer may finally go. As each weld is made, the stop moves the pointer closer, until it reaches the place where the pointer hardly moves away from the stop during a weld.\* You may find that the pointer will move away from the stop sometimes, but not on all the welds. This shows the variation in current discussed in Sec. 14-7.

**6-5. Current Transformer.**—The pointer-stop ammeter, like many other ammeters, carries only 5 or 10 amperes of current, so a current transformer is used to reduce the large line current to this 5 or 10 amperes. Split-core "clamp-on" current transformers are handy and suitable for line currents up to 1500 amperes (see Fig. 6B). Other current transformers may be

\* In an emergency, an ordinary ammeter can be used in the same way by removing its cover glass. Use a toothpick to move the pointer up the scale until the pointer hardly moves during the weld. Protect the instrument from moving air and dirt.

In the same way, an ordinary voltmeter can be used to measure a voltage dip during the weld. Since the voltage becomes less during the weld, the toothpick should move the pointer down the scale until the pointer hardly moves lower during the weld.

used, connected into the line. Be careful never to open the ammeter circuit while welder current is flowing.

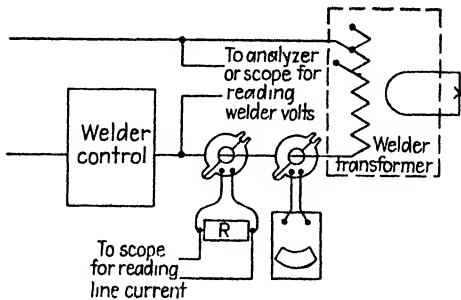

FIG. 6B Welder power circuit, showing instruments connected

**6-6. Cycle Recorder.**—While measuring the line current, it is also desirable to know the number of cycles during which the current is flowing. When the ignitrons are controlled by accurate timers, the length of each weld will be shown by the dial setting of the timer. The welds per minute can be counted, using a watch. A more accurate way is to use a cycle recorder (Fig. 6C),

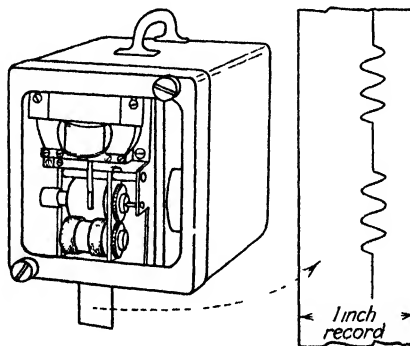

FIG. 6C.—Cycle recorder.

which draws a record that shows each separate cycle of current flow. The cycle recorder may have a current coil for use with a current transformer or may be used with a resistor and connected like a voltmeter across the welder transformer primary. In either case the recorder needle will draw a small wiggle for each cycle when current flows, but a straight line at other times. The record paper is moved by a small motor inside the cycle recorder

at a speed of about 5 inches each second, so this motor should be started by a momentary contact switch\* or push button. The cycle recorder is fine for general use in the plant, for checking the timing of machine-tool control circuits and for sequencing of relays.

**6-7. Oscilloscope.**—The oscilloscope is an instrument that makes a picture of the quick changes of voltage during  $\frac{1}{60}$  second, or any small part of a cycle. Since all tube controls respond to

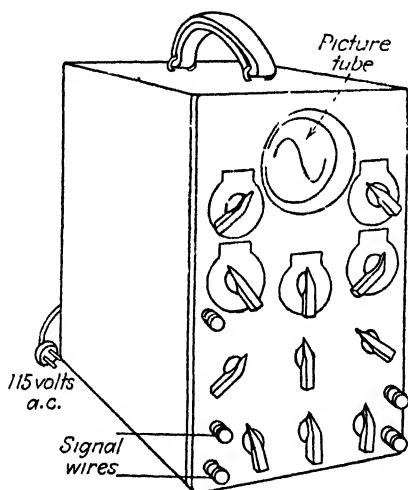

FIG. 6D. Cathode-ray oscilloscope.

voltage signals shorter than  $\frac{1}{60}$  second, the best way to see or follow the operation of tubes is with an oscilloscope,<sup>4-15</sup> often called a "scope." One of the many types of oscilloscope (\$50 to \$100) is shown in Fig. 6D. The complete name of an instrument like this, which makes a picture on the circle in front, is the *cathode-ray oscilloscope*, because the circle is one end of a cathode-ray tube. Some call it a "CRO," but we shall call it an oscilloscope or scope.

**6-8. The Oscilloscope Picture or Image.**—The picture shown on the circle screen of the oscilloscope in Fig. 6D happens to be the curve of a-c voltage during just one cycle.<sup>2-2</sup> This curve is

\* A two-pole switch is preferred so that the recorder needle does not move except when the record paper is moving. In this way, longer life of graphite rolls is obtained.

the picture that the oscilloscope makes, to show whatever electrical signal is coming into the scope on the pair of wires from some circuit that is being studied. Many circuits around tube controls do not have a smooth curved wave shape like this "sine wave" shown in Fig. 6D. (For example, see Fig. 4C.) The shape of the picture depends upon whatever is happening in the outside circuit being studied. Usually this same thing is happening over and over again, many times each second, so the picture on the scope screen appears steady or still. If something changes suddenly in the outside circuit, it instantly changes the picture on the scope screen. By watching this picture, you learn just what has changed in the outside circuit, even though the change lasts for only part of a second.

By turning the dials on the oscilloscope, you can adjust the brightness and sharpness of the picture line, center it on the screen, and change the height or width of the picture. Other dials let you show just one cycle on the screen, as in Fig. 6D, or three or four cycles side by side, or only some part of a single cycle wave. These adjustments are described in the oscilloscope instruction book.

**6-9. Oscilloscope Features for Best Results.**—There are various sizes of oscilloscope, called the 2-, 3- and 5-inch sizes, referring to the diameter of the exposed screen end of the cathode-ray tube. For welder service, the 2- or 3-inch size is better than larger sizes because it is lighter to carry, costs less, and gives a more compact picture image that is easier to watch. Most standard oscilloscopes are built for radio service and do not include all the good points for work on welder controls. A standard scope should include focus control, linear sweep, synchronizing voltage, amplifier, horizontal and vertical beam adjustments and frequency ranges as low as 10 or 15 cycles per second. The transparent ruled screen is desirable in front of the circular scope screen. Before such a standard oscilloscope can be used for servicing complete welder controls, certain changes must be made to give (1) direct reading for d-c voltages, without amplifier, and (2) high-impedance-input voltage divider.

If the following brief instructions are not enough, then have these changes made by a good radio shop. Some types cannot be modified.

1. Be sure all standard features are supplied on the oscilloscope, including easy provision for synchronizing the image with the 60-cycle supply fre-

quency. If not already provided, this synchronizing signal can usually be got from one of the 6-volt tube heaters and applied through a switch and capacitor to the synchronizing input circuit.

2. Remove blocking capacitor so the scope can show d-c voltages as well as a-c voltages. Since standard scopes are intended for a.c. only, they have a protective blocking capacitor in series with the vertical input signal circuit. In this circuit there also may be a switch marked "Amplifier On-Off," or with similar wording. In the "off" position of this switch, the capacitor is usually connected so as to block the d-c centering voltages away from the input. Move this capacitor, with its connection to the centering voltage, to the other side of the amplifier switch, so that the capacitor is now in circuit only when the amplifier is in use. With amplifier "off," the signal voltage is now applied directly to the picture-tube plates.

NOTE: This circuit change is easily made only in scopes that have the deflecting plates near ground potential. Luckily some scopes have the

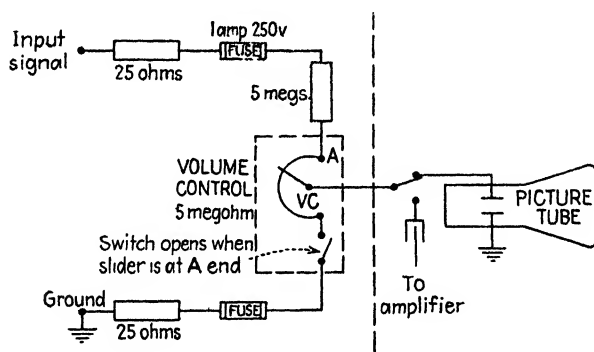

FIG. 6E. - Voltage-divider circuit for oscilloscope.

picture-tube plates directly connected to terminals outside the case, and then connected by jumpers to the amplifier output. On such scopes d-c signals can be connected to these plate terminals without making any internal changes.

When the incoming signal goes direct to the plates, the standard scope has no way to adjust the height of the picture on the screen, so it may be off scale. To provide such adjustment:

3. Add the voltage divider. To equip a scope with the voltage divider circuit suggested in Fig. 6E, all the parts to the left of the heavy dotted line must be added and mounted inside the scope. These parts are small and not too costly. With this voltage divider installed, the height of the picture image is adjusted by turning the volume control VC. This divider should also make it possible to receive inputs at voltages higher than the rating of the scope alone.\*

\* The changes noted above are further described by B. L. Weller in Servicing Resistance Welding Controls, *Electronics*, January, 1943.

**6-10. Using the Oscilloscope.\***—The oscilloscope is really a special kind of voltmeter and can be used to study voltages at most parts of tube-control circuits. The scope must be connected to a lighting circuit, or other 115-volt a-c supply, to warm the tubes inside the scope. In addition to instructions furnished with the oscilloscope, the following things should be watched:

Do not touch the metal oscilloscope case while it has any electric circuit connected to it. The scope receives its input from two wires connected to the vertical and ground terminal posts, and you may have connected these two wires to dangerously high voltages. Whatever voltage is on the wire connected to the ground post is also on the case of the scope, so "Hands Off"! The scope should always rest on a dry board or other good insulator. Stand on another dry board when adjusting the scope.

Use only the best quality wire† leads, with high-voltage insulation, for connecting the scope to the circuit being studied. Long insulated test clips at the ends of the leads will help reach places far inside the control panel. Inspect these leads and clips carefully each time they are used.

Place the oscilloscope far away from the welder or any other circuit carrying large current. A cable or welder carrying many amperes of current within 5 or 10 feet can affect a sensitive instrument like the oscilloscope and make the picture change its shape. To see whether the scope is being affected in this way, operate the scope by itself before connecting its input leads to the circuit being studied. To do this, connect the vertical post to the ground post with a wire and adjust the knobs or dials to show a horizontal line on the screen. Then operate the welder or whatever load you are studying, and also operate other machines near the scope; be sure that none of them make the line on the scope screen move or change shape. (A change in supply voltage to the scope can also make the line move.) When the scope is in a place where it is not affected, remove the wire between the vertical and ground posts and connect the scope leads to whatever you wish to study.

**6-11. Counting Cycles.**—If the scope has a sweep frequency range of 10 to 15 per second, the scope can show 4 to 6 cycles on the screen at once. If the scope leads are connected in a

\* Further oscilloscope advice is given in Sec. 22-5.

† Microphone cable is excellent for this purpose.

welder circuit, it is possible to count the number of cycles in a weld as short as 2 or 3 cycles, and thereby check the adjustment of very sensitive time controls.

**6-12. Measuring Voltage Changes.**—Since you can change the height of the picture on the scope screen by merely turning one dial, the scope will not directly tell you whether the measured circuit voltage is 15, 150 or 440 volts. However, by using a voltmeter or analyzer along with the scope and connecting both across the same a-c voltage, you can adjust the scope to give a wave picture, say 2 inches high (from top to bottom), when the voltmeter reads 220 volts a.c. steadily. When the welder operates, if the picture suddenly decreases to only  $1\frac{1}{2}$  inches high during a voltage dip, this shows that the voltage has dropped to 165 volts, even though the voltmeter pointer is not fast enough to move to this lower value.

**6-13. Using the Oscilloscope to Study Current Flow.**—The oscilloscope can be used to show a-c voltages smaller than 1 volt when the amplifier is "on." The low secondary voltages of a welder transformer can be easily studied. This low-voltage response also lets a scope be used to show a picture of current flow. The scope is not an ammeter, but it can show how the amperes of current are changing in a circuit. In order to do this, the two leads from the scope are connected to any two points of the circuit that have as much as 1 volt difference between them, caused by the current flowing through this part of the circuit. Figure 6B shows a current transformer used with a scope in order to give the current flowing in the welder circuit. Here a low resistance  $R$  is connected in the secondary or low-current circuit of the current transformer. When large current flows in the welder circuit, small current flows through the resistance  $R$ , making several volts difference between the two ends of resistor  $R$ . These few volts across  $R$  are enough to make the scope show a picture of the current flowing in  $R$  or in the welder circuit.

**6-14. Magnetic Oscillograph.\***—Some people prefer this instrument instead of a cathode-ray oscilloscope, although the

\* The difference between an oscillograph and an oscilloscope is that the oscillograph is arranged to make permanent film records of its screen images, but an oscilloscope is arranged only for looking at the picture screen. An oscillograph is being used as an oscilloscope when the operator merely looks



price\* is greater. The magnetic oscillograph does not use a tube screen, so its picture is not affected by being too close to high-current circuits. The magnetic oscillograph, by itself, can show two or more different electrical quantities at the same time, such as volts and amperes.

For use especially in the study of welding circuits and tube controls, a single-element magnetic oscilloscope is available† at lower cost. In this instrument the image shows only sidewise movement; the device is useful for watching voltage dips or current symmetry since there is complete freedom from the distortion often experienced with the cathode-ray type.

---

at the image and does not make a picture record of it. However, a magnetic oscilloscope produces its image or picture by a light beam reflected by tiny mirrors, which are moved by magnetic devices; the cathode-ray oscilloscope produces its image or picture by controlling an electronic beam inside the picture tube.

\* First cost alone should not control the choice between a cathode-ray oscilloscope and a magnetic oscilloscope. To get accurate current readings, a magnetic oscilloscope is needed. The cathode-ray oscilloscope can often measure or respond to very sensitive circuits, which cannot work a magnetic oscilloscope.

† LEVOY, L. G., JR., and C. H. SCHERMERHORN, *New Oscilloscope: An Aid to Good Resistance Welding*, *Gen. Elec. Rev.*, July, 1941.

## CHAPTER 7

### THE TIME-DELAY RELAY— MEASURING TIME FOR WELDER OPERATION

So far we have studied only the main power circuit to the welder transformer, and have seen how the welder current can be started and stopped by a magnetic contactor or by a pair of ignitron tubes. But now the question is "How long should the current flow in the welder circuit, and what will control this time?"

Twenty years ago most welding was done by a foot pedal which pressed the electrodes onto the work. Later the welding machine used a motor-driven cam to control the electrodes. In recent years the electrodes or points have been pressed together by motor or air pressure, but welding current passes during only a part of the time while the points are together. The length of time of current flow is controlled by a timer or time-delay relay. These time-delay relays have sometimes been motor-operated timers or timers having air bellows to delay the closing of some electrical circuit. Many such mechanical time relays are still used and operate well, especially where they do not operate often. Such time relays, used with magnetic contactors, can time welders at  $\frac{1}{10}$  second (6 cycles).

**7-1. Tubes for Timing.**—Today the weld must often be made in less than 6 cycles and needs a timer that can work ten or a hundred times a minute, all day long. In such fast service the moving parts of a mechanical time relay will wear and need repair. So, to work along with a fast ignitron contactor, we need a time relay that is also tube-operated.\* General-purpose time-delay relays, operated by small radio tubes, are being used in industrial plants to give time-delay periods from 3 cycles up to several minutes. We shall now study such a time-delay relay for several reasons:

1. This relay is used on many welding machines and in other places in most plants.

\* The use of a tube does not mean that this relay gives synchronous timing.<sup>14-11</sup>

2. It has a circuit using a tube, but it is easy to understand.

3. This same circuit is used when several such time relays are connected together in one box to make an automatic weld timer or sequence control for timing all the operations of a welding machine, as described in Chap. 9.

**7-2. Parts of the Time-delay Relay.**—This time-delay relay\* is shown in Fig. 7A, and its connection diagram is Fig. 7B. This

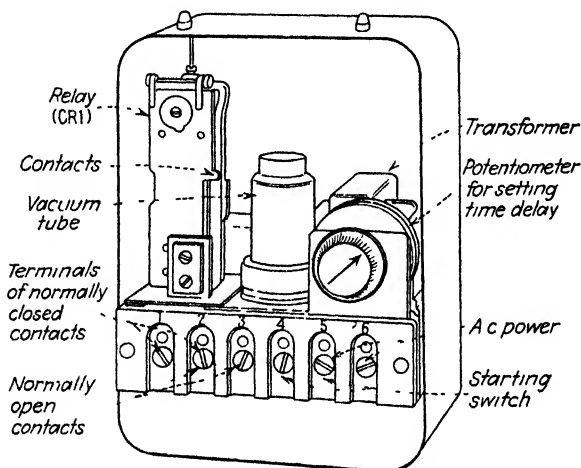

FIG. 7A Time-delay relay, tube-operated.

relay operates† from the electric supply lines (115 or 230 volts a.c.). To start this relay timing, the switch is closed between relay terminals 4 and 5. Within the time relay there is a contact between terminals 2 and 3, which closes after waiting a certain time. This contact may be used to start some other electrical operation. We want to learn what makes this relay wait for a time, and how we can change the length of this time when we wish to do so. Since this time-relay circuit is tube-operated, or electronic, there are several new things we must study. We

\* Any relay is a device that waits until it gets a signal from some electrical circuit and then it works some *other* circuit. The relay CR1 in Fig. 7A works instantly as soon as it is energized (by electric voltage applied to its coil). However, the name *time-delay relay* refers to the whole equipment shown in Fig. 7A because, after the starting signal is received at terminal 4, all the parts inside the box work together to delay the closing of the load circuit connected between terminals 2 and 3.

† Suggestions for servicing this time-delay relay are given in Chap. 12.

must learn how small tubes work. The capacitor (or static condenser), which is  $C1$  in Fig. 7B, is also new to us.

First, there are two different kinds of circuit diagram, each of which can show us things about this relay. Figure 7B is the *connection diagram*, which shows all the parts of the time-delay relay in the places where the parts are mounted. Figure 7C is the *elementary diagram* of this same time-delay relay. Figure 7C is not used for checking wiring connections, but it is better for showing how the time-delay relay works.

**7-3. Connection Diagram.**—If you take the chassis, or frame, out of the enclosing case shown in Fig. 7A and look at the under-

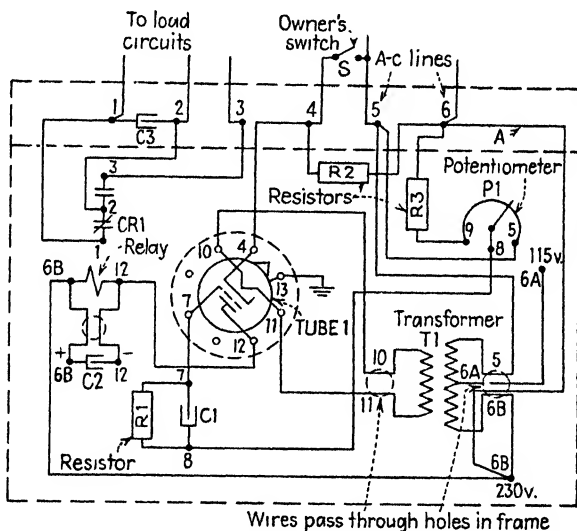

FIG. 7B. —Connection diagram, CR7504 time-delay relay.

side of the frame, holding it so that the six numbered terminals are at the top, then all the various parts will be seen in the places shown in Fig. 7B. Figure 7B is called the connection diagram because it shows the wire connections between the various parts, arranged just as they are when you trace the wires from one part to another. It even shows where the wires pass through holes from the bottom to the top of the frame. Look for the resistors  $R1$ ,  $R2$  and  $R3$  or the capacitors  $C1$ ,  $C2$  and  $C3$  exactly where they are shown on this connection diagram. Both windings of the transformer are shown close together, since they are

wound around the same iron core. Lead *A* remains connected to 6*B* when a 230-volt supply is used but is moved to 6*A* when the supply is 115 volts.

**7-4. Elementary Diagram.**—The diagram of Fig. 7*C* does not try to show the various parts in the places where they are mounted. Instead, the same circuit is drawn so that it is easier to understand and so that the wire lines do not cross more than necessary. For example, on the elementary diagram of Fig. 7*C*, see how easily you can follow the circuit from terminal 5 up through the transformer to point 6*B* and back to terminal 6.

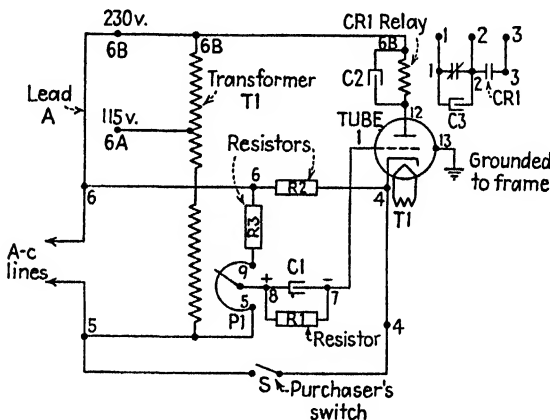

FIG. 7*C*.—Elementary diagram, CR7504 time-delay relay.

Now try the same thing on Fig. 7*B* and see how you turn and cross before you get from 5 to 6*B* to 6. On the “elementary,” notice that the two transformer windings *T1* are shown in different parts of the circuit, where each winding belongs.

**7-5. Vacuum-tube Symbols.**—The radio tube used in this circuit has parts that are named in Fig. 7*D*. The tube symbol used in the elementary diagram is a single circle. The symbol for the same tube in a connection diagram is a dotted circle outside a solid circle. The solid circle represents the tube itself, so all parts within the solid circle are inside the tube as you buy it from the radio store. (This inner circle is often shown dotted also. On some diagrams an all-metal tube is shown as a solid circle, and a glass tube as a dotted circle.) The outside dotted circle represents the socket into which the tube pins fit, so any

wire going out from this dotted circle represents a wire connection from the pin contact\* of the socket to other parts of the equipment.

In the elementary diagram, socket connections are not shown, so it usually makes no difference whether the grid or cathode connections are shown coming out at the right or at the left side of the tube circle. Most actual connections are made to pins at the bottom of the tube. If we compare these tube symbols with the ignitron symbols in Fig. 3C, we see that both kinds of tube have an anode and a cathode. However, in the small

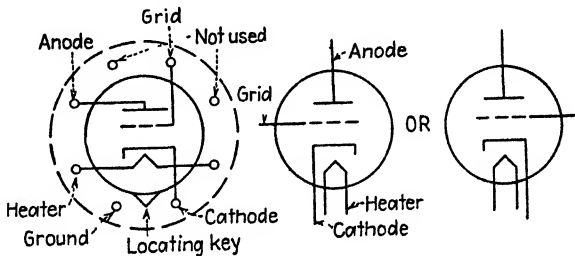

FIG. 7D.—Vacuum-tube symbols.

radio tube the grid is used instead of an igniter, and the heater or filament is added to keep the cathode at a high temperature. Since there is no mercury pool and no gas or vapor in the radio tube, the symbol does not include a dot. The symbol without a dot is used for a vacuum tube. Now we must learn what things are done by these various tube parts and how these tubes work.

**7-6. Discovery of the Vacuum Tube.**—Back in the days when Thomas Edison was making the first electric light bulbs, he discovered something else that has become as valuable as his light bulb. He was working with a light that had a filament heated by electric current, and this filament was sealed in a glass bulb from which all air had been removed—the early standard vacuum light bulb. As an experiment, he had made this bulb

\* Notice that there are eight pin contacts shown on the socket, although two of the contacts are not used. This is the "octal" (eight-pin) socket, which is standard for use with many radio tubes. Since the pins on the tube are all the same size, you could not tell which way to fit the tube into the socket, so a locating or aligning key is furnished on the tube; this lets the tube fit only one way into the socket.

with an extra piece of wire sticking through the glass, as shown in Fig. 7E. With the lamp lighted, he closed a circuit that applied voltage from a battery to this extra wire, and he discovered that a small amount of current was flowing into the wire. Since the wire ended in space inside the glass bulb and since glass could not carry electric current, he knew that this light bulb was letting the current pass right through the vacuum or space, returning through the filament connection to the battery. This discovery is still called the "Edison effect," and upon it all electronic equipment depends. Edison quickly learned that the current decreased when he lowered the temperature of the lamp filament, and that the current stopped entirely when he reversed the battery. Current flowed only when the (+) battery terminal was connected to the extra wire. Current would not flow from the hot filament to the wire.

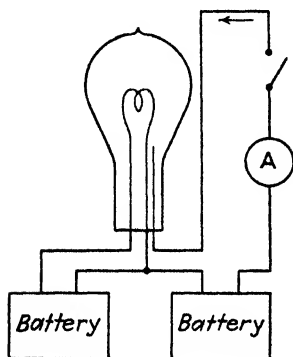

FIG 7E The Edison effect  
- current through space

temperature of the lamp filament, and that the current stopped entirely when he reversed the battery. Current flowed only when the (+) battery terminal was connected to the extra wire. Current would not flow from the hot filament to the wire.

**7-7. Current through a Vacuum Tube.**--The simplest tube today works in the same way as Edison's trial light bulb worked. If a tube has a hot filament or heater inside the space where there is no air, current can still flow into the tube through an extra wire that we now call the *anode*, or *plate*. In this

simple tube, the heater is also the *cathode*. The voltage, or electrical pressure that forces current through the tube from the anode to the heated cathode, is called the *anode voltage* of the tube. This current is called the *anode current*, or *plate current*. As long as the voltage at the anode is more positive than that at the cathode, anode current flows from anode to cathode. There is nothing to prevent this current from flowing, just as there is nothing to keep water from flowing through a check valve when the water pressure is in the right direction. If the water pressure reverses, the check valve prevents water flow backward through the check valve. In the same way, this tube is an electric check valve, which lets current pass from anode to cathode, but not from cathode to anode. This one-way action is called *rectifying* or *rectification*, and any simple tube acts as a *rectifier*.

**7-8. Controlling the Current.**—So far, the current passing through this simple tube can be changed or controlled only by changing the anode voltage or by changing the temperature of the heater. We know now that this anode current flow can also be changed by connecting another wire into the tube and placing this wire between the anode and the heater. This new wire is called the *grid*. The wire by itself has no effect on the current flowing through the tube until a small voltage is connected to this grid wire. If the voltage at the grid wire is made more positive than the voltage at the cathode, then anode current can flow. But when the voltage at the grid wire is made more negative than that at the cathode, the anode current decreases or stops entirely. The current flowing through the tube can be increased or decreased merely by changing the voltage on the grid. Notice two things that are very important. First, there does not need to be any current flowing through the grid wire, for just the electric pressure or voltage is all that is necessary. Second, this electric pressure or grid voltage is really the voltage measured between the grid wire and the hot cathode. We do not care what voltage is measured between the grid wire and the anode—that is not what controls the current flow through the tube. In Chap. 8, we shall take a good look inside this tube and see just how this grid voltage controls the current flow.

**7-9. The Tube Circuit.**—Having learned how the vacuum tube is controlled by changing the voltage on its grid, we are now ready to see how the tube is used in the circuit of the time relay. Instead of trying to study the whole circuit of Fig. 7C at once, let us start with just the part shown in Fig. 7F, which does not include the time-delay action. Since this circuit operates on a.c., the voltage at 6 is changing from (+) to (-) and back to (+), 60 times each second. The 230-volt pressure between 5 and 6 cannot force any current through tube 1 until switch *S* is closed. When *S* is closed, current can flow from 6 to 6B, through CR1 relay coil, down through tube 1 to 4, and through switch *S* to 5. This happens during only those half-cycles of alternating current when 6 is (+) and 5 is (-). During the other half cycles, when 5 is (+) and 6 is (-), the voltage tries to force current back through *S* and up through tube 1, but the tube will not pass current in this direction from cathode 4 to anode 12. While *S* is closed, the current flowing down through



tube 1 also flows through *CR1* relay, which energizes this relay, making it "pick up" and operate its contacts. Do not forget that the flow of current through tube 1 is also controlled by the grid of the tube. So, let us find out if the voltage at the grid 7 will let tube 1 pass anode current or not. In Fig. 7*F* a wire connects grid 7 to the slider of potentiometer *P1*, so whatever voltage there is at the slider is also the voltage at grid 7. To tell whether this voltage at grid 7 will let tube 1 pass current or not, we must trace the circuit from grid 7 through *P1*, until we can reach cathode 4 of tube 1. Why? Because, to let tube 1 pass current, grid 7 must be more positive than cathode 4. Now, see what *P1* does.

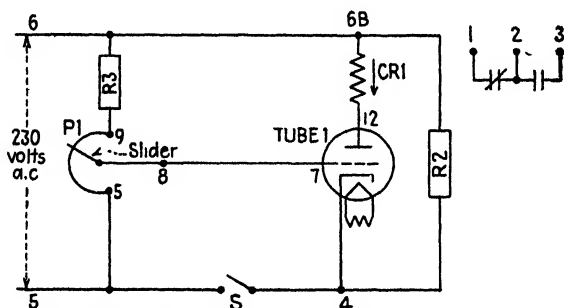

FIG. 7*F*.—Simple tube circuit, without time delay.

**7-10. Potentiometer and Voltage Divider.**—The potentiometer *P1* is made of resistance wire connected between points 9 and 5. A slider touches or makes contact against this wire, but a knob is used to move this slider and change the place where the slider touches the wire. The 230 volts between 5 and 6 forces current through resistor *R3* and through the resistance of potentiometer *P1*. When 5 is (+), current flows from 5 up through *P1* to 9, through *R3* to 6. When 6 is (+), current flows from 6 down through *R3* to 9, through *P1* to 5. The only time tube 1 can pass current is when 6 is (+), so that is also the time when the voltage at the slider is most important. Starting at 6, which is now 230 volts more positive than 5, the voltage decreases as you trace down through *R3*, and continues to decrease gradually all through the wire of *P1*. *R3* and *P1* divide this 230 volts into smaller parts; any group of resistors connected like this is called a *voltage divider*. When the slider of *P1* is

touching the lower end, there is no voltage difference between 5 and the slider, but, when the slider is turned so it touches 9, then the slider is about 100 volts more positive than 5. When the slider is touching about half way between points 9 and 5, the slider is about 50 volts more positive than 5. Notice that, no matter where the slider is touching between 9 and 5, the slider voltage is more positive than at point 5.

**7-11. Grid Circuit.**—When switch  $S$  is closed in Fig. 7*F*, the grid voltage of tube 1 is found by tracing the circuit from grid 7 to slider, down from slider through  $P1$  to 5, through  $S$  to the cathode 4 of tube 1. The only voltage in this circuit is the voltage between the slider and 5, and the slider is more (+) than 5. Therefore the grid 7 is more (+) than the cathode 4, and tube 1 will pass current or fire. Using only the part of the circuit shown in Fig. 7*F*, closing switch  $S$  makes tube 1 pass current instantly, energizing  $CR1$  relay, which closes its contact 2 to 3 or opens its contact 1 to 2. Now, where is that time delay which the whole relay of Fig. 7*A* is supposed to give?

To get that time-delay action, a resistor  $R1$  and a capacitor  $C1$  must be added in the grid circuit between 7 and 8, to keep tube 1 from firing so soon. But what is this capacitor and how does it delay the firing of tube 1?

**7-12. Capacitors.**—A capacitor is a savings bank for electricity. Electricity can be stored in a capacitor and taken out again when wanted. A capacitor is sometimes called a *static condenser*, or just a *condenser*. There are different sizes of capacitor just as there are different sizes of resistor. While a resistor is measured in ohms,<sup>2-10</sup> a capacitor is measured in "mikes" or microfarads (the abbreviation is " $\mu f$ " or "mfd," or more recently "mu f"). As used in welder controls, a very small capacitor, such as one of 0.01 mu f, is about the size of a nickel, and one of 5 mu f is often as big as a package of cigarettes.

Each capacitor is tightly sealed and has two wires for connections. To what do these wires connect inside the capacitor? One wire connects to a strip that looks like tin foil but is usually very fine aluminum. The other wire connects to another strip of aluminum foil. To separate one strip from the other, there are strips of very thin paper. These two metal-foil strips, with the paper between them, are then rolled up (Fig. 7*G*) until they take very little space. After they are placed in a container, the

air is sucked out of these rolls and nonburning oil (askarel) is added; then the whole capacitor is sealed. It sounds simple, until you learn that there is to be as much as 600 volts\* pressure between these two aluminum strips wound up so close together. Figure 7G shows how most capacitors are made in roll form. An earlier form, made of many flat metal strips interleaved, looks somewhat like the symbol  which is now used to show a capacitor.

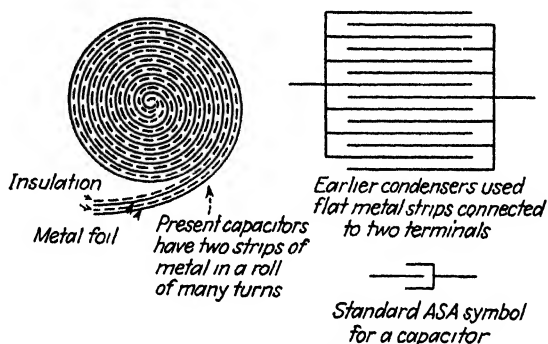

FIG. 7G—Capacitors

**7-13. Charging a Capacitor with D.C.**—When voltage is connected to or applied across the two wires of a capacitor, current will flow through the wire until the capacitor has stored up all the electricity that it can hold. It is now *charged* with electricity, and it can hold this electricity for a long time. The amount of electricity it can hold depends on the design and size of the capacitor, and also on the voltage to which the capacitor is charged. If a supply of 110 volts d.c. is touched to the two capacitor wires or terminals, the capacitor will still have 110 volts between these terminals after the d-c supply is removed or shut off. The capacitor is holding electricity in the form of electric pressure between its metal strips. This capacitor is shown in *a* of Fig. 7H. Figure 7II shows how a capacitor may be compared to a strong rubber balloon, which has two openings *A* and *B* and which is made with a rubber separator *S* through the middle so that the balloon may be made larger, by connecting water pressure to either opening *A* or *B*. When water pressure

\* Larger capacitors operating at 1000 to 3000 volts are a very important part of the welding equipment described in Chap. 29

(11 pounds per square inch) is connected to opening *A*, separator *S* moves to the left and the balloon stretches to a certain size, but gets no larger. If the water pressure is shut off by valve *V*, the balloon remains stretched and holds a certain quantity of water. Now, in *b*, if greater water pressure (22 pounds) is applied when *V* is open, the balloon is made still larger. With *V*

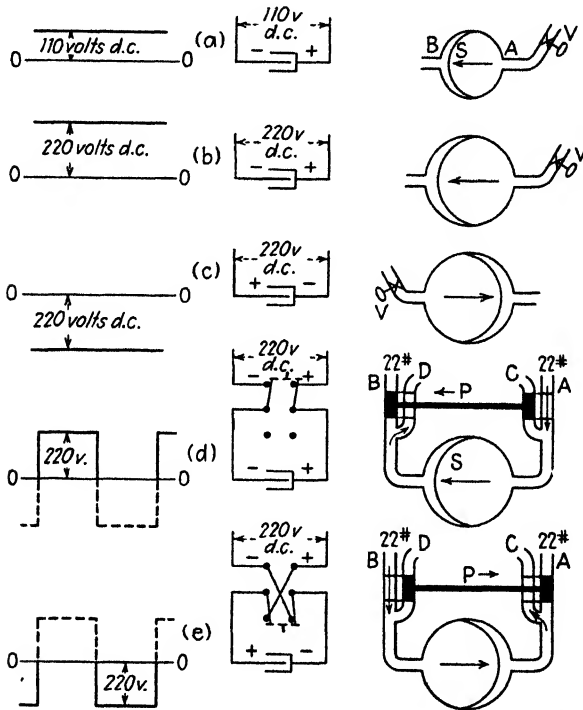

FIG. 7H.—Capacitor charged on d.c., an operation similar to filling a balloon with water.

shut again, the balloon holds more water than in *a*. In the same way, if the capacitor is charged with 220 volts d.c., the capacitor holds this voltage and a larger amount of electricity. If the d-c supply leads to the capacitor are reversed, as in *c*, the capacitor charges up to the same voltage as in *b* but with opposite polarity, that is, the capacitor wire that had been (+) is now (-). If 22 pounds pressure is connected to the balloon through opening

*B*, the balloon reaches the same size as in *b*, but the separator *S* is stretched toward the right.

If several two-way valves are connected into two water lines as shown in *d* of Fig. 7*H*, the balloon is first filled with water through opening *A*, when valve piston *P* is to the left. Then, when piston *P* moves to the right, as in *e*, water pressure is applied to the balloon through the opening *B*, forcing the first water out through *C*. This same effect is obtained by connecting the capacitor to d.c., using a reversing knife switch, thrown upward in *d* and downward in *e*. With switch up, the capacitor is charged to 220 volts of one polarity, but with switch down the capacitor is charged to 220 volts of opposite polarity.

**7-14. A Capacitor on A.C.**—If two wires from a 60-cycle a-c supply are touched to the capacitor terminals, the capacitor is charged by the a-c voltage. This a-c voltage changes the direction or polarity of the charge on the capacitor, as though the reversing switch (shown in Fig. 7*H*) were being thrown upward (*d*) 60 times each second and downward (*e*) 60 times each second. Since the a-c voltage is changing its direction by itself, the switch is left out in Fig. 7*I*, where the capacitor is shown connected to a-c lines. In *f* the capacitor is charged by the voltage during a positive half-cycle (above the 0-0 line), while *g* shows the capacitor  $\frac{1}{2}$  second later, charged the opposite way during a negative half-cycle.\*

Notice that, although current is flowing in both directions through the wires to the capacitor, no current is flowing *through* the capacitor, any more than water is passing *through* the balloon. So, on a.c., a capacitor stores energy during only half a cycle, and it gives this energy back into the line when the line voltage reverses. If we could prevent the current to the capacitor from reversing its direction, we could make the capacitor charge

\* In *f* of Fig. 7*I* the 220-volt line does not reach to the top of the a-c wave. Because of the shape of this a-c sine wave, more than 220 volts is needed at the top of the wave in order to get the same effect as with a straight line of 220 volts d.c. The voltmeter shows 220 volts on its scale when it is connected to a circuit that has 312 volts ( $\sqrt{2} \times 220$  volts) at the top of the wave. Therefore, in a 220-volt a-c circuit, the voltage is as high as 312 volts for an instant during each cycle. If 220 volts a.c. is connected across a capacitor, the capacitor can charge up to 312 volts. The 220 volts a.c. is called the *effective voltage*, or *rms voltage* of the circuit, in which 312 volts is the *crest voltage*.

up in only one direction and could hold this charge or energy for useful purposes.

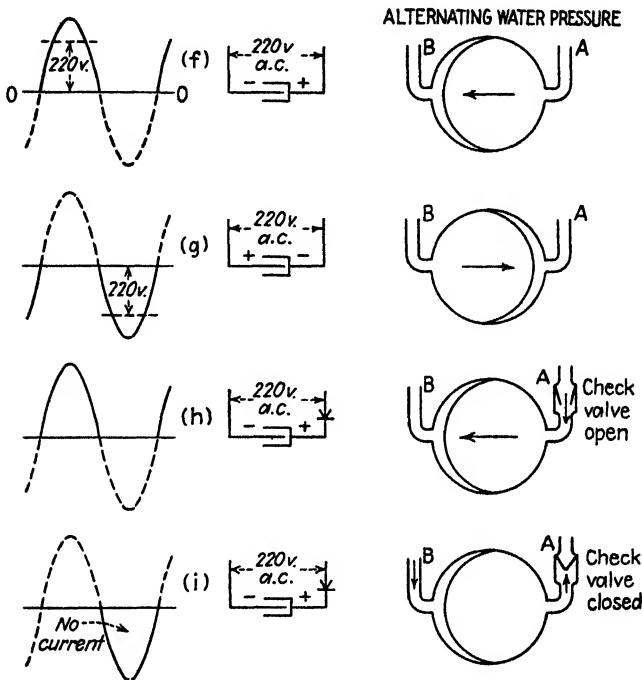

FIG. 7I.—Capacitor charged on a.c.

**7-15. Keeping Capacitor Charged on A.C.**—A capacitor can be used in many ways, for example, to produce time delay, to prevent arcing at contacts or to prevent chattering of relays. In each case the capacitor does its job because it can store up energy and can give up its stored energy when needed. For time-delay work, the capacitor needs to store its energy during many cycles of time, so, if such a capacitor is to operate on a.c., something must be done to keep the a.c. from forcing reverse current through the capacitor. In *h* of Fig. 7I, a copper oxide rectifier is used to let the current flow into the capacitor during the positive half-cycle. The action of this rectifier<sup>4-12</sup> prevents current from flowing the opposite way during the negative half-cycles in *i*. This works the same as a check valve placed in the water line A, which lets water flow from A into the balloon but prevents water

from flowing out of the balloon even when water pressure is trying to force water from *B* into the balloon. Instead of a copper oxide rectifier to hold the charge on a capacitor, a tube may be used. Any tube acts as a rectifier (passes current only in one direction), so current can flow from anode to cathode and also from grid to cathode (whenever grid is more positive than cathode). A capacitor connected in either the anode or grid circuit of a tube can be charged in only one direction. The capacitor holds this charge in the same way, whether the tube circuit operates on d.c. or on a.c. This is the way the capacitor *C1* is charged through the tube in Fig. 7*L*. Before discussing Fig. 7*J*, we must learn how the capacitor is discharged slowly, so as to cause time-delay action.

**7-16. Discharging a Capacitor.**—When a capacitor is charged either from d.c. or a.c. by methods just described, it holds its voltage for some time. How long the capacitor holds its voltage or charge depends on what is done to discharge it or to prevent it from discharging. When the voltage supply to the capacitor is removed or shut off, the capacitor is left holding a definite amount of electricity, which it will try to get rid of through any path or circuit that it can find. If a big piece of metal is touched across the two capacitor terminals, the capacitor discharges instantly, usually causing a spark because of the sudden flow of discharge current. If a circuit of higher resistance (such as a long fine wire or a 10-ohm resistor) is touched to the capacitor terminals, the capacitor will lose its voltage or charge much more slowly, and the discharge current will be less. If a higher resistance (like the 10,000-ohm resistor in Fig. 7*J*) is connected across the terminals, the capacitor may discharge so slowly that several seconds or minutes may pass by before the capacitor voltage is nearly gone. With no discharge circuit connected at all, the capacitor may still discharge through the very high resistance of the materials between its terminals, but this may take many minutes or hours. From these cases, we see that the capacitor can be discharged quickly or slowly, and this depends upon the resistance of the circuit across the capacitor terminals. The discharge may be fast at first, but always becomes slower as the charge decreases. (A capacitor can also be charged slowly.)

If the balloon shown in Fig. 7J is filled by water pressure and the valve is then shut, the balloon will stay full until the valve  $R$  is opened, letting water escape or discharge from the balloon. If  $R$  is opened wide, the water escapes quickly and the balloon collapses at once. If  $R$  is turned just part way open, water escapes more slowly, for there is greater resistance to flow in the valve  $R$ . If  $R$  permits only a slow drip, the resistance of  $R$  is now so great that it may take many minutes to drain the balloon. The length of time needed to empty the balloon depends on the opening or resistance of valve  $R$  and also on the size of the balloon. When  $R$  is first opened, the water flows fast, but slows down as the balloon gets smaller and has less pressure.

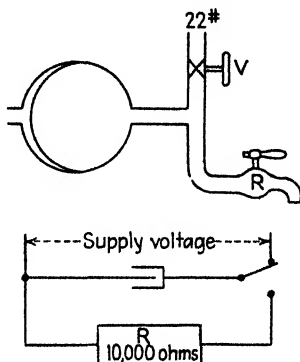

FIG. 7J. Discharging capacitor through resistor.

**7-17. Useful Rate of Discharge.**—The rate of capacitor discharge may be fast at first, but it always becomes slower as the capacitor charge or voltage decreases. This is shown in Fig. 7K, where the capacitor voltage decreases to one-third its full pressure in 5 seconds, yet 10 seconds later there is still some voltage left.

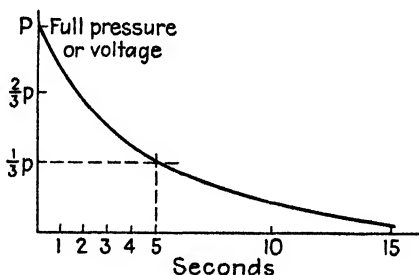

FIG. 7K.—Speed of capacitor discharge.

In many tube circuits, only the decrease in capacitor voltage from full pressure down to one-third pressure is used for accurate results. If the size of the capacitor is known (in microfarads) and also the discharge resistance (in megohms, which equal  $\frac{\text{ohms}}{1,000,000}$ ), then the length of time required for the capacitor



voltage to decrease to approximately one-third its starting value is shown by this relation:

$$\text{Time(seconds)} = \text{capacitor size (mu f)} \times \text{resistor(megohms)}$$

For example, a 1-mu f capacitor, discharging through 5,000,000 ohms (5 megohms) requires about 5 seconds to discharge to one-third of the voltage it had at the start.

**7-18. Time-delay Grid Circuit.**—Returning now to the grid circuit of the time-delay relay mentioned in Sec. 7-11, Fig. 7L shows this circuit, in which capacitor  $C1$  and resistor  $R1$  have now been added to delay the firing of tube 1. First, see how  $C1$  becomes charged. When switch  $S$  is open, current flows in the circuit from the slider of  $P1$  through  $R1$ , through tube 1 (by the path from grid 7 to cathode 4), up through  $R2$  to 6, the top side of the supply circuit. (Cathode 4 is at about the same voltage as 6, which is more negative than grid 7.) This current can flow only when the slider is more positive (+) than 6, so this happens when 6 is (-) and (5) is (+). This is the half-cycle when tube 1 cannot pass current, whether  $S$  is closed or not.

If the slider of  $P1$  is touching point 9, the voltage from slider to 6 is about 130 volts a.c. Perhaps 15 volts of this is used in passing through tube 1. Since  $R1$  is such a large resistance (3 megohms) compared with  $R2$ (10,000 ohms), nearly all this remaining 115 volts appears across  $R1$ . The voltage across  $R1$  is caused by current flowing through  $R1$ . Since this current flows from 8 to 7, 8 is the (+) end of  $R1$  and 7 is the (-) end of  $R1$ . Capacitor  $C1$  charges up to the crest<sup>7-14</sup> of this a-c voltage, or nearly 165 volts. This means that grid 7 is now about 165 volts more negative than 8. Since the rectifying action of the grid-cathode circuit of tube 1 prevents current from flowing through  $R_1$  in the reverse direction (7 to 8),  $C1$  is freshly charged as long as  $S$  is open. As tube engineers would say,  $C1$  is charged by *grid rectification* through tube 1.

To start the time-delay action, switch  $S$  is closed. This connects cathode 4 to line 5, and current cannot flow through the grid circuit. (Reason: When 6 is (-) and 5 is (+), cathode 4 is more positive than grid 7. Also, when 6 is (+) and 5 is (-), the grid 7 is still more negative than cathode 4 because of the 165-volt charge on  $C1$ .) Capacitor  $C1$  receives no more charging current through the grid circuit, but is just left alone, gradually losing its charge through  $R1$ . There is still some voltage across

$C1$ , which is still (+) at 8 and (-) at 7. However, after a number of cycles or seconds have passed, this  $C1$  voltage will have become so small that it cannot prevent tube 1 from passing current. The time needed for  $C1$  to discharge and let tube 1 fire is also the length of the time delay provided by this entire time-delay relay.

Using this circuit of Fig. 7L, now trace the complete grid circuit at the instant when  $S$  is first closed and 6 is (+) (as in Sec. 7-11). Trace from grid 7 to point 8, to slider, to 5, to cathode 4. There are two voltages in the circuit: first, the "hold-off" 165 volts across  $C1$ , which is negative on the side toward the grid and which tries to keep tube 1 from firing; second, the "turn-on"

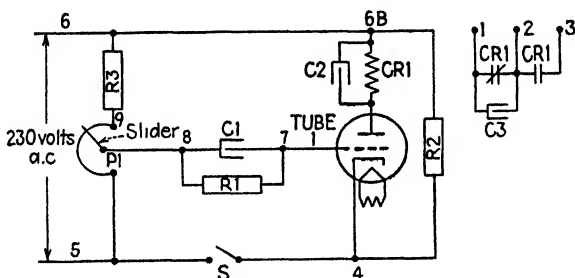

FIG. 7L.—Complete tube circuit, with time delay.

voltage between the slider and 5, which is positive on the side toward the grid. These two voltages oppose each other. At first the "hold-off" voltage is the larger. When it has decreased so that it is smaller than the "turn-on" voltage, then tube 1 can pass current.

**7-19. Watching This Grid Circuit Work.**—If the slider of  $P1$  in Fig. 7L is turned to the 9 end, then a picture of what happens to the grid voltage of tube 1 is obtained (see Fig. 7M). The swinging voltage is the a-c voltage between slider and point 5. The smooth line is the d-c voltage across capacitor  $C1$ , which slowly gets nearer the zero line. These two voltages combine to show the voltage on the grid of tube 1. At the instant when  $S$  is closed, this  $C1$  voltage is about 165 volts negative or below zero. Subtracted from this capacitor voltage, the swinging a-c voltage rises to within about 25 volts of the zero line. After 3 or 4 cycles (which is the time delay for which this relay is now set), the d-c capacitor voltage has decreased enough to let the

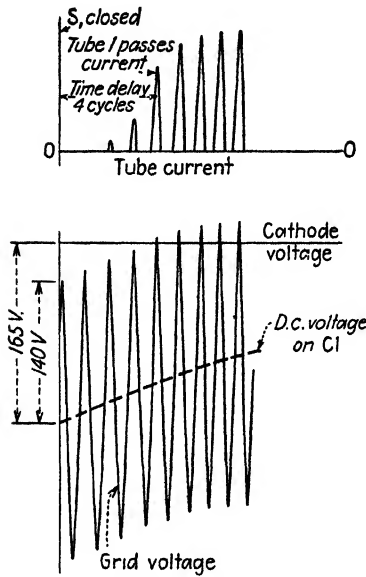

FIG. 7M.—Changes of grid voltage during short time delay.

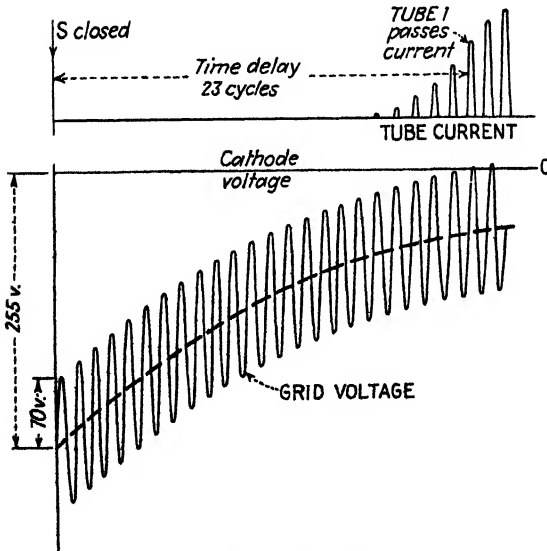

FIG. 7N.—Changes of grid voltage, longer time delay.

swinging a-c voltage rise above the zero line (which means that the grid voltage is no longer negative or below the cathode voltage). As soon as the grid voltage is enough above the zero line, tube 1 passes enough current to energize *CR1* relay, and the time-delay action is completed.

Figure 7*N* shows what happens to the grid voltage of tube 1 when the slider of *P1* is set about halfway between 9 and 5. At the instant *S* is closed, the d-c voltage across *C1* is about 250 volts. This is larger than before because *C1* is charged by the larger voltage between 6 and the new position of the slider. Also, the a-c swinging voltage is smaller than before, since the voltage between the slider and 5 is only half of the voltage between 9 and 5. The d-c voltage approaches zero, as it did before, but it needs much longer time before it can boost the swinging a-c voltage above the zero line and make tube 1 pass current. The time delay is longer.

If the slider is at the 5 end of *P1*, there is no a-c voltage in the grid circuit. Capacitor *C1* is charged to nearly 300 volts and needs more than 50 cycles of time before it discharges enough to let tube 1 pass current.

**7-20. Changing Length of Time Delay.**—For the circuit of Fig. 7*L*, the length of time delay is changed by moving the slider of *P1*. Movement toward 9 gives shorter time. But what part of the circuit controls the maximum time (when the slider is at 5), to decide whether it shall be 50 cycles, 12 seconds, or 2 minutes? The combination of *C1* and *R1* controls this time. In this one standard relay, *C1* is 0.1  $\mu$  f and *R1* is 3 megohms, and the time-delay can be adjusted from 3 cycles to 54 cycles, when working at 115 volts. Another standard relay may use .2  $\mu$  f and 2 megohms, giving time-delay adjustment between 0.6 and 12 seconds. The combination of 4  $\mu$  f and 10 megohms in another relay can give a 2-minute time delay. In an emergency, the time range of a relay can be changed by substituting different values of *C1* or *R1*. This is a delicate operation and is not generally recommended.

**7-21. More Uses of Capacitors.**—In Fig. 7*L* capacitor *C2* is shown connected in parallel with the coil of *CR1* relay. Why? In Fig. 7*M*, notice that the anode current that finally flows through tube 1 is not a steady current. It flows for only a half-cycle at a time, with no current for the half-cycle between because

of the rectifying action of the tube. This same current flowing through the coil of *CR1* relay would make *CR1* relay chatter or vibrate. Capacitor *C2* is used to decrease or prevent this vibration. During the half-cycles when tube 1 passes current, *C2* is charged up to the highest voltage across the coil. Then, when tube 1 is not passing current, *C2* discharges through *CR1* coil, making current flow to fill in part of each missing half-cycle.

In Fig. 7L capacitor *C3* is connected across the normally-closed (n-c) contacts of *CR1* relay. These contacts are intended to carry about 1 ampere of load. Each time the time-delay relay circuit energizes *CR1* relay, these contacts must open the load circuit, perhaps many times each hour or minute. Capacitor *C3* is used to prevent too much burning or arcing at these contacts. While the contacts are closed, there is no difference in voltage between the two connections to *C3*, and *C3* holds no charge. When the n-c contacts open, the energy in the circuit (which causes the arcing and burning) is used instead to charge *C3* to the voltage across these opened contacts. Much longer contact life is obtained, especially where the contacts must open the circuit of a contactor coil or other inductive device.

**7-22. Connection for Proper Voltage.**—Figure 7L shows the time-delay relay working from a 230-volt a-c supply. Returning to the complete diagram in Fig. 7B or 7C, notice that transformer *T1* permits the time-delay relay to be used at either 115 or 230 volts. The relay is usually received connected for 230 volts, and will not work that way on 115 volts. For use at 115 volts, lead *A* must be moved from terminal 6B to terminal 6A, inside the relay. With 115 volts between 5 and 6A, *T1* still produces 230 volts between 5 and 6B. When connected for 230 volts, the time delay is about 20 per cent longer than at 115 volts.

The circuit of this time-delay relay is of further interest, for it is used as part of the automatic weld timer discussed in Chap. 9. However, before weld timers are studied, the tubes used in such welder controls require closer attention.

## CHAPTER 8

### THE THYRATRON TUBE

The thyatron tube is used in most tube controls, except in the ignitron contactors of Chap. 3, where ignitrons are used alone. The thyatron has a heater or filament, grid, anode and cathode, just like the vacuum tube discussed in Sec. 7-7. The thyatron is not a vacuum tube, for inside it there is gas or vapor. The vacuum tube and the thyatron tube will be discussed here together to show clearly just how each tube does its job.

Some years ago the names Thyatron or Ignitron were used as trade names by the two companies that made these tubes. They no longer have such meaning, for the ignitron today is any mercury-pool tube controlled by a starter or ignitor, regardless of who makes it. The thyatron is a gaseous tube of the heated type controlled by a grid, regardless of who makes it.

**8-1. Purpose of the Thyatron.**—The thyatron is used to pass and control currents that are too small for the ignitron and too big for the radio or vacuum tube. The ignitron carries hundreds or thousands of amperes; the radio tube carries hundredths or thousandths of an ampere. The thyatron carries amperes, usually from  $\frac{1}{20}$  to 20 of them. These 20 amperes can supply a very small spot welder directly, which is more than ignitrons can do. However, in the control of welders, thyatrons are most often used to control ignitrons, or to do the delicate job of accurately timing welds, as is done by equipment described in later chapters of this book. Small thyatrons are used in the weld timers of Chap. 9, in the same way that vacuum tubes are used in the time-delay relay of Chap. 7.

**8-2. Types of Heated Tube.**—Thyatrons and radio tubes belong in a large family of heated (or thermionic) tubes, which cannot work well unless their cathodes are hot. Other tube names are often heard, such as triode, phanotron, pentode, pliotron. These various names of heated tubes are given in Table III, where the second column (high-vacuum tubes) includes those generally called *radio tubes*. The gaseous tubes of the

right-hand column are the tubes most frequently found in welder controls and other industrial electronic equipments. A plotron or thyatron is also called a *triode* because it has 3 elements— anode, cathode and grid. Notice that the filament or heater does not count as another element, even when it is separate from the cathode. The radio tube used in the time-delay relay of

TABLE III.—TYPES OF THERMIONIC (HEATED) TUBE

Number of elements	High-vacuum types	Gaseous types
2 . . . diode	Rectifier Kenetron	Rectifier Phanotron
3 . . . triode	Plotron Oscillator	Thyatron Grid-glow Controlled rectifier
4 . . . tetrode	Screen-grid tube	Thyatron (shield-grid) Thyatron (double-grid)
5 . . . pentode	Suppressor-grid tube	

TABLE IV.—THYATRON TUBES IN WELDER CONTROLS

Anode current, average amperes	Type		Cathode	Grid
	Westing- house	General Electric		
0 075	WL-630	GL-2051	Indirect heater	Shield
0.075			Indirect heater	Shield
0.5			FG-97	Coated filament
0.5	KU-627	FG-17	Coated filament	
0.64			Coated filament	
1.5			Coated filament	
2.0	KU-628	GL-393	Coated filament	
2.5	WL-631		Coated filament	
2.5	WL-632	FG-57	Indirect heater	
2.5			Indirect heater	Shield
2.5			Indirect heater	Shield
6.4	KU-676	FG-95	Indirect heater	
6.4			Indirect heater	
6.4			Indirect heater	Shield
12.5			Indirect heater	
12.5		FG-105	Indirect heater	Shield
		FG-41	Indirect heater	
		GL-414	Indirect heater	Shield

Chap. 7 is a triode, or three-electrode amplifier, for it has an anode, cathode, and one grid.

Types of thyatron are given in Table IV.

**8-3. Thyatron Tube Symbols.**—Several types of thyatron tube are shown in Fig. 8A. The small tube (Type GL-2051)

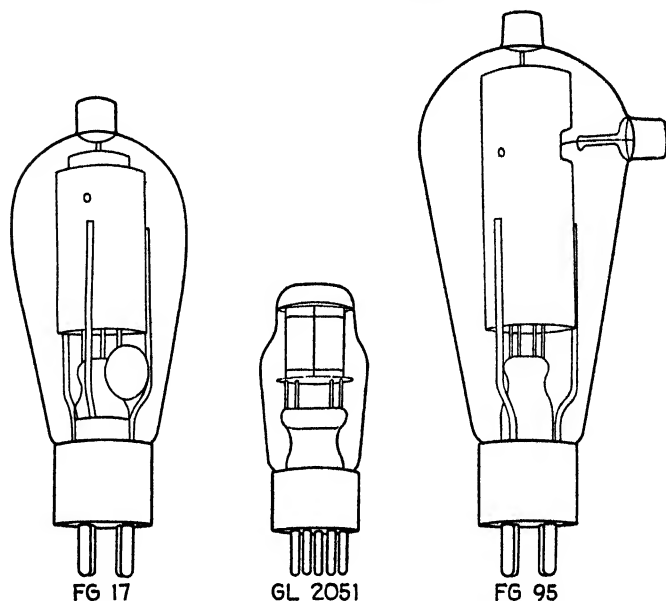

FIG. 8A.—Types of thyatron tubes.

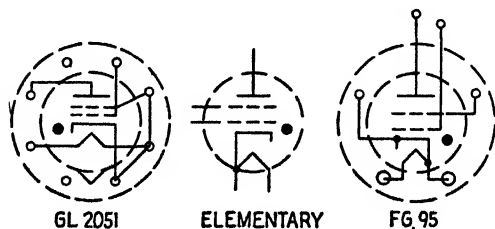

FIG. 8B.—Symbols of double-grid thyatrons.

is used in weld timers and sequence controls, while the larger tubes (FG-17 and FG-95) are used in complete welder controls. The signs or symbols used to show these tubes on diagrams are given in Fig. 8B. As previously mentioned,<sup>7-5</sup> the symbol used on an elementary diagram has only one circle and does not try



to show whether the connections come out of the tube on the side, the top or the base. The complete symbol (with one circle inside another circle) shows the location of the socket contact and base pin to which each tube connection is made, when seen from the bottom of the socket. Notice that both of these thyratrons have separate cathodes, heated by filaments; both have two grids brought out separately. The complete 2051 symbol shows all tube connections brought out to base pins, and also shows that the cathode, heater and shield grid have been connected together at the socket (not inside the tube). The complete FG-95 symbol shows only four tube pins or socket

connections, while the anode and control grid connections are not in the socket at all. (Figure 8A shows the anode connection at the top of the tube, with the control grid at the side.) The large base pins are the heater or filament connections. Since the tube can fit this socket in only one way, no locating pin is

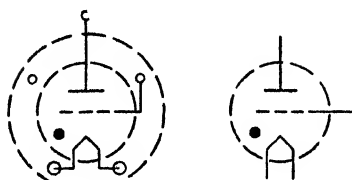

FG 17

FIG. 8C. —Thyatron symbol (single grid, direct heater).

needed. In all symbols the dot shows that the tube is of the gaseous type, containing mercury vapor or other gas.

Another thyatron (FG-17) is shown by the symbols of Fig. 8C. It is seen that this tube is also of the gaseous type (dot inside inner circle). It has the anode connection direct to the tube (not connected at the socket), but its control grid is connected to one of the base pins. There is only one grid. This tube is a "direct heater" and the cathode is the coated filament itself.

**8-4. Current through a Thyatron.**—As in other tubes, current passes through a thyatron from the anode to the cathode, but never in the opposite direction. This anode current can flow only when the anode is more positive than the cathode, for this is the only time when the circuit voltage can force current to flow from anode to cathode. However, the flow of this anode current can be prevented entirely if the grid voltage is sufficiently negative. As already shown,<sup>7-11</sup> this grid voltage is the voltage measured between the grid and the cathode. For any average thyatron, no anode current will flow as long as the grid is 10 or

20 volts more negative than, or below, the cathode potential. This negative grid voltage prevents the thyatron from starting to pass current, and is called the *negative bias* of the tube. However, as soon as the voltage between the grid and the cathode is decreased almost to zero, or if the grid is made more positive than the cathode, the thyatron fires instantly or as soon as its anode is also positive.

**8-5. Difference between Thyatron and Vacuum Tube.**—In both the thyatron and the vacuum tube, the grid has the power to prevent the tube from starting to pass current. Except for this, these two tubes work quite differently. In the vacuum tube, the grid has the power to control the amount of current flowing through the tube and the grid also can decrease or stop this current flow entirely. At any time the anode current is under the complete control of the grid; it increases as the grid becomes more positive and decreases as the grid becomes negative. See how the grid of the thyatron has been robbed of these powers, simply because the thyatron contains mercury vapor or other gas. Although the grid can prevent the thyatron from starting to pass anode current, the grid loses control just as soon as this anode current starts. The thyatron grid has no control over the amount of anode current flowing, for this amount depends entirely on the rest of the circuit outside the tube (just as the amount of amperes flowing through a closed magnetic contactor depends on the voltage and load of the rest of the circuit that the contactor controls).

The thyatron grid is not able to stop the anode current after it once starts. The only way this anode current can be stopped

\* A thyatron tube will not pass current if its grid is more negative than its cathode by some certain amount. This required amount usually increases as the applied anode voltage increases, for example, a certain thyatron is kept from passing anode current when its grid potential is  $-5$  volts (the grid is 5 volts more negative than the cathode) and its anode voltage is 200 volts (more positive than the cathode). If the anode voltage increases to 400 volts, the grid potential of  $-5$  volts is unable to keep the tube from firing or passing current. To prevent current flow at this higher anode voltage, the grid potential must be made perhaps  $-10$  volts. This potential which the grid must have in order to prevent the flow of anode current is called the *critical voltage* of the tube. This critical voltage is so close to zero that, for the purposes of this book, it will be assumed that a thyatron tube may fire or pass current only when its grid potential becomes slightly positive, or above the 0-0 line of cathode voltage.

is by removing or stopping the anode voltage. Luckily, in any a-c circuit, this anode voltage removes itself, or reverses, after each half-cycle of time. This voltage reversal lets the anode current stop flowing, and the grid then regains its power to prevent this anode current from starting again.

**8-6. Mouse Trap and a Water Faucet.**—The vacuum tube works like a water faucet, since just a half-pound of twist on the faucet handle (grid) will control 40 pounds of water pressure and let water (anode current) flow. Turning the faucet handle farther will increase the water flow, and turning the handle back can decrease or shut off the water flow. The flow of water (anode current) is completely controlled by the faucet handle (grid).

In contrast, the thyatron works like a mouse trap. Here again a very small pressure will control or release the much larger force stored in the coiled spring of the trap. But Mr. Mouse does not "get it in the neck" any harder merely because he takes a bigger bite of the cheese. Too little pull on the trigger does not trip the trap, and the trigger remains in complete control. However, a stronger pull on the trigger does trip the trap, but the force of the snap (amount of anode current) does not depend on the amount of pull (grid voltage) on the trigger. Also, after the trap has tripped, the trigger is quite useless and cannot release Mr. Mouse. The spring pressure (anode voltage) must be released or removed. With the thyatron, the removal of anode voltage also resets the trap, or lets the grid once more control the instant when the tube will next be tripped.

**8-7. Electrons.**—In any electron tube, current flows in one direction, from anode to cathode. As shown below, this anode current is made of electrons, which come only from the cathode, whether the cathode is the mercury pool of an ignitron tube or the heated part of a vacuum tube or a thyatron. Electrons flow only from cathode to anode, for the anode is not heated and cannot produce electrons to flow back to the cathode. Let us take a good look inside a heated tube to see just how the current flow is controlled. After all, what is this current?

How would you describe the current in a river? Little drops of water going places! Also, the electric current in a wire could be little pieces of electricity going places. But what are these pieces of electricity? Nobody really knows, but people speak

of electric current as being made of very tiny things called *electrons*. It is these electrons that can pass right through the space inside the tube. We know that electrons can flow only one way through a tube. More than that, we know that the electrons must come out of the cathode and flow into the anode. Why do we know that? Because a tube can pass more current when the cathode is hot than when the cathode is cool. This shows that the electrons, which really are the current, are being made at the hot cathode. These electrons, after coming out of the hot cathode, simply wander around unless they are attracted somewhere. The anode attracts these electrons, but only when the anode is positive (+). Electrons flow from the hot cathode to the positive anode.

**8-8. Positive (+) Attracts Negative (-).**—When we play with magnets, we know that each magnet has one North end and one South end. We also learn that the North end of one magnet will attract the South end of another magnet, but will push away the North end of that other magnet. From this comes one of the laws of electricity, that anything which has a (-) charge or voltage will be attracted by something that has the opposite, or (+), charge. Also, anything that has a (-) charge will be pushed away by something that also has a (-) charge. The electrons mentioned above are attracted to the anode when the anode is (+), so this means that the electrons themselves must be (-) or have negative charges.

**8-9. Negative Grid Repels Electrons.**—To get from the cathode to the anode, the electrons must pass near the grid,

which is made of a metal ring or wires placed between the cathode and anode (see Fig. 8D). If the grid has the same voltage as the cathode, the grid has no effect on these electrons. If the

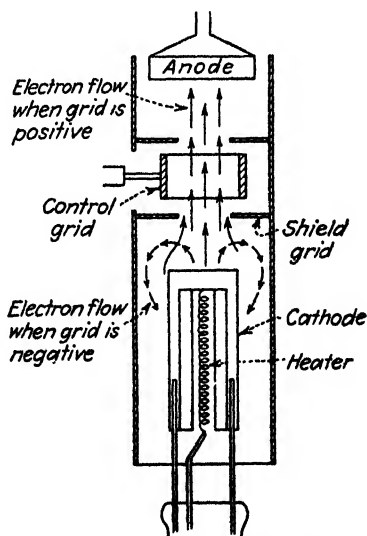

FIG. 8D.—Electron flow inside a thyratron.

grid is more positive than the cathode, the grid gives the electrons a helpful pull toward the anode. But if the grid has a voltage more negative than the cathode, the grid repels or pushes the electrons back toward the cathode. When the grid of a vacuum tube is only slightly negative, it cannot repel all the electrons, so some of them get through to the anode. To make a tube fire or pass current, put a (+) voltage on its grid. To prevent anode current, put a (-) voltage on the grid.

At this point, notice that several things do not seem to agree. The electrons flow from cathode to anode. The electrons are the tiny particles that make up the current. Yet the current flows through the tube only from anode to cathode. This is hard to make clear, but the following may help.

Back before the days of vacuum tubes and radio, scientists knew that electric current flowed in one direction, from one side of a battery through a load to the other side of that battery. Nobody could see electricity and nobody knew which way the electricity went. So we guess that the scientists marked one side (the carbon or copper electrode) of the battery (+) and marked the other (zinc) side (-), then flipped a coin and decided that the current flowed always from the (+) to the (-). That decision still holds in all modern electrical practice. But meanwhile, since electrons first started to flow through space inside tubes, it has been proved that electrons flow from (-) to (+). If electrons are the same as current, then the coin must have landed wrong side up. Since it was now too late to change all the standard electrical practices, the only way out was to decide merely that *negative* electrons did flow inside a tube in a direction opposite to the current flowing in the rest of the circuit outside the tube. So, throughout this book, the flow of current will always be from (+) to (-), whether the current is flowing through a wire, a resistor or a tube. The only place where electron flow will be mentioned will be *inside* the tube, and then only to explain how the tube itself works. When circuits are explained, the current in a tube circuit will flow only from anode to cathode, and then only when the anode is (+) and the cathode is (-).

**8-10. Electrons in a Thyatron.**—The electrons that pass through the space inside a vacuum tube all come out of the heated cathode. Although there are millions of these electrons, yet these millions make only a small part of an ampere. Then where do the billions of electrons come from which produce the amperes of current in a thyatron? The hot cathode gives out electrons in both kinds of tube, but the thyatron electrons get help from the mercury vapor or gas inside the tube. The electrons bump into the small particles of gas and give these gas particles the power also to act like electrons and carry current. Each original

electron from the cathode is a good "persuader"—it gets a thousand gas particles to help it carry the current. It gives these gas particles this power by putting electric charges on them, or *ionizing* them. When the gas particles are charged by the cathode electrons, so that the gas carries current, the gas is *ionized*. Before anode current starts to flow in a thyatron, the electrons from the cathode can be controlled by the grid, just as easily as the electrons in a vacuum tube. When the grid once lets the electrons start to pass through to the anode, these electrons immediately ionize the gas. The total number of all the electrons, including these ionized gas particles, is so great that the grid can no longer control them.

This is like a police officer directing traffic near a school, where hundreds of children wait to cross the street. As long as the children stand at the curb, watching the officer, they are easily controlled by his signal. When he has let them start across, he cannot stop them, except for a few near by.

When the current stops flowing through a thyatron (because anode voltage is removed), some small time is needed before the electric charges disappear from the gas particles. The time required to remove these charges or to deionize the gas, is called the *deionization time* of the tube. If anode voltage returns to the thyatron during deionization time, the tube will still pass current, touched off by the few particles that have not yet lost their electric charges. Since the deionization time is usually 1/10,000 to 1/1000 of a second, this explains why thyatrons are not used to control high-frequency circuits such as 1000 cycle a.c.

**8-11. Cathode Separate from the Heater.**—With more heat at the cathode, there are more electrons that can carry greater current. The heat does not make the electrons; it merely sets them loose from the cathode surface. In many tubes, enough electrons can be got from the hot surface of the heater or filament itself. But the kind of metal that makes the best heater does not necessarily produce the most electrons. In some tubes, therefore, the cathode is made separately, of a different material, and is merely heated indirectly because it is close to the hot filament. This is like making pancakes. Pouring the pancake batter directly onto the heating element of an electric stove is not the best practice, although there certainly is enough heat there to cook the pancake. Instead, a griddle is used above the heating

element, not because the griddle is any hotter, but because it has a surface that is better for making a pancake all in one piece.

In a tube that has a heater and a separate cathode, the heater has no use except to keep the cathode hot. The anode current flowing through the tube goes to the cathode and not to the heater. The electric supply to the heater may be entirely separate from the circuit to the cathode and anode, as shown in tube 1 of Fig. 7L.

**8-12. Electron Emission.**—The amount of current that a tube can safely carry depends upon the quantity of electrons that can be given off by the cathode. The producing or giving off of electrons from the cathode is called *electron emission*. The electron emission from the large mercury pool of an ignitron tube<sup>8-1</sup> is very great, which explains why the ignitron can carry such large currents. The red-hot filament or cathode of a thyratron cannot emit enough electrons to carry such large momentary currents. If the heater voltage is too low, the cathode is so cool that the thyratron cannot properly carry even its rated full-load current. Here the anode current is greater than the normal supply of electrons. This makes the cathode “sputter” or throw off little pieces of its surface-coating material, and this damages the cathode of the tube. If some of this “sputtered” material lands on the grid of the tube, the grid may lose part or all of its control (because the grid can now also produce or emit electrons from this sputtered material).

**8-13. Shield-grid Thyratron.**—Among the thyratrons listed in Table IV are several shield-grid thyratrons. The symbols of Fig. 8B show thyratrons that have a control grid and also a shield grid. Figure 8D shows this shield grid, which is a metal cylinder encircling the anode at the top and the heated cathode at the bottom. The flow of electrons or current is usually inside this cylinder and passes through the smaller openings just below and above the control grid. Notice that the shield grid protects the control grid, so that the control grid is not in the direct path from cathode to anode. Since the control grid cannot “see” the cathode, the control grid will not be hit by any particles “sputtered” from the cathode. As a result, the control grid does not lose its control during normal tube life, and such a shield-grid thyratron can be safely operated from a more sensitive grid circuit.

The shield grid is connected to a separate pin at the tube base, but most welder-control circuits connect this shield grid to the cathode at the tube socket. The shield grid may also be used separately as a second control grid, as mentioned in Sec. 24-9. In the tube symbol, the control grid is always the dotted line closer to the cathode. The shield grid is shown farther from the cathode, or closer to the anode.

**8-14. Warming Tubes.**—All thermionic tubes, which need heat to help produce electrons, must be given enough time to reach their normal temperature. Most small gaseous tubes, like the GE-83 rectifier or GL-2051 thyatron, become hot enough in 10 to 15 seconds. Direct-heated tubes whose coated filaments are their cathodes, like the FG-17, are ready for use in 30 or 40 seconds. The larger thyatrons with separate cathodes need 5 minutes of warming time. The cathode must become hot enough, and this heat must sufficiently increase the gas pressure within the tube before it can safely carry load current. All welder controls using these thyatrons should include a time-delay relay to prevent these tubes from passing anode current until they have been heated for 5 minutes.

Whenever a larger thyatron is warmed for the first time, as when starting a new control panel, installing a replacing tube or using any tube that has been in stock, that tube should be warmed 15 minutes before letting it carry load. Some of the liquid mercury may be caught in upper parts of the tube, so 15 minutes of heating may be required to "boil" this mercury out of these parts and let it come to its usual place at the bottom of the tube. When tubes are removed for a few minutes, keep them standing up until they are placed back in service.

When a new tube is first heated, notice the cloudy or dirty appearance of the glass during the first few minutes. This is the mercury deposited on the cool glass, after it has been driven off the inside parts of the tube. This soon disappears.

The top of a thyatron must always be warmer than the bottom. If any hot tube shows mercury condensing near the top, look for a draft of cool air moving down over the tubes. Thyatrons containing mercury need room temperatures well above 50°F. When started on a very cold morning, thyatrons may not work well for the first half-hour.

**8-15. Blue Light in the Thyatron.**—When current flows through any tube containing mercury vapor, a blue light or glow



appears inside the tube. This blue light is separate from the orange color of the hot filament or cathode. This blue light will tell when a thyatron is passing current or is firing. A very faint blue glow, usually seen only when looking into the top of a thyatron, shows that current is passing from the grid to the cathode, even when the anode connection is removed from the tube.

In tubes that have a metal cylinder outside the cathode and anode, as in a shield-grid thyatron, the blue glow is not seen except at the cylinder ends, through the control-grid opening or through a  $\frac{1}{8}$ -inch hole in the cylinder wall. If such a thyatron glows brightly so that blue light seems to fill the glass outside the metal cylinder, that tube is overloaded or defective or is not heated enough for proper operation.

**8-16. Voltage across a Thyatron.**--When a tube is not passing anode current, the anode voltage (measured between anode and cathode) may be the whole supply voltage. When a vacuum tube passes anode current, the anode voltage may be any amount less than supply voltage, and is controlled by the grid. In contrast, when a gaseous tube like a thyatron passes anode current, the anode voltage immediately decreases to a low value, 15 to 20 volts, which is called the arc drop<sup>8-9</sup> or arc voltage of the tube. This voltage remains about the same whether the tube carries overloads or very small loads.

Similarly, the grid voltage (measured between grid and cathode) is often several hundred volts, as long as no current flows from the grid to the cathode. However, as soon as the grid becomes a few volts more positive than the cathode, a small current flows through the tube from grid to cathode. This positive grid voltage cannot be greater than the arc drop through the tube, so any excess positive voltage appears across the resistor in the grid circuit.

## CHAPTER 9

### THE AUTOMATIC WELD TIMER

Most spot welders have some kind of timing control, except those simple welders that are worked entirely by foot or hand pressure. The automatic weld timer includes all those things that make the welder go through its operation automatically, after the operator gives the starting signal. When the operator steps on the foot switch (for spot welder) or squeezes the hand button (for gun welder), he starts\* the automatic weld timer, which takes over the job of making the electrodes come together, passing welding current and then separating again. On motor-driven welders many of these operations may be controlled by cams turned by the motor.

**9-1. Arrangement of Timing Control.**—On many welders the timing control includes devices scattered over the machine, such as a pressure switch on the welder head, a mechanical or tube time-delay relay in its separate box or a micro-switch operated by some small movement of a welder part. Many of these devices can be replaced by additional time-delay relays, and some welders have a number of timers separately mounted. However, welders are now usually built with all the various time-delay relays combined in one box. If this box includes a relay for timing the length of current flow to make the weld, it is called an *automatic weld timer*. When the box does not include a relay for timing the length of flow of welding current, it is called a *sequence control* and is used along with a separate device that does nothing but control the flow of welding current (such as synchronous controls in Part II). Neither the automatic weld timer nor the sequence control alone gives synchronous control of the weld.

\* Most weld timers or sequence controls are non-beat. This means that a complete welding sequence or operation is carried through, even when the foot or initiating switch is closed and immediately opened again. A timer is sometimes arranged for use with a two-stage foot switch. Pressing such a switch part way lets the welder electrodes come together without passing any current. When pressed all the way, the switch causes complete welder operation.

Each maker of weld timers and sequence controls builds 5 to 25 different types or arrangements, which include time-delay relays for various periods of operation of the welding machine. The names of these welder times are shown in Fig. 9A and are further explained below.

**9-2. Squeeze Time.**—When the operator presses the foot switch or button, the welder electrode tips or points come together immediately, but there must be a small time delay before it is safe to pass welding current. This time delay between the operator's signal and the start of welding current is called the *squeeze time*, for it is the time required for the electrodes to

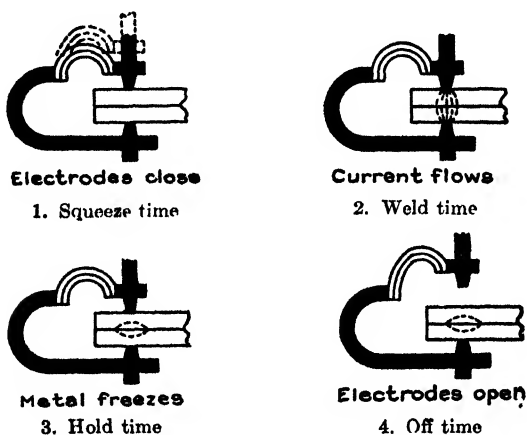

FIG. 9A.—Sequence of spot-welding machine.

squeeze together properly. If current flows before the points squeeze the work, there is too much heat at the points, causing a flash and burning of the work and points. To understand this, remember that the weld heat is made by the large current passing through the resistance of the metal pieces being welded.<sup>2-11</sup> In making a weld, the metal pieces are squeezed together by enough electrode pressure so that the resistance, measured from one piece to the other piece, is quite low. When the electrodes do not squeeze with this pressure, the resistance between pieces is much higher, so the heat produced by the passing of current is also much higher.

In many welders, the operator's signal closes the circuit to an electric solenoid valve. This solenoid valve has a moving

plunger, which opens a pipe so that air or hydraulic pressure is applied to a cylinder in the welder. The pressure in this cylinder moves the electrodes together and makes the points squeeze the work. Part of a second of time is needed for the valve and cylinder to work, so the squeeze time is made long enough to allow the points to squeeze the work with the right pressure.

Instead of a squeeze timer, some welders use a pressure switch that closes its circuit only when the pressure between electrodes builds up to the desired amount. Other welders use neither a squeeze timer nor a pressure switch, but use the circuit within a small micro-switch, which is closed by the slight movement between two parts of the welder head when the electrodes squeeze together.

In motor-driven spot welders, the operator's signal starts a motor that makes the electrodes come together, under pressure usually applied by a cylinder above. This motor also turns a cam that closes an electric contact at the right time to let welding current pass through the electrodes.

**9-3. Weld Time.**—At the end of the squeeze time, or when the electrodes hold the work with the right pressure, current is passed through the welder by the closing of a magnetic contactor or the firing of a pair of ignitron tubes. The total length of time, from the start of this current flow until the end of the current needed to make that one weld, is called the *weld time*. The length of this weld time is controlled by one of the time-delay relays in an automatic weld timer, as used with a magnetic or ignitron contactor. When a separate synchronous<sup>1b-1</sup> panel completely controls the weld current and the length of its flow, this weld time is usually omitted and a sequence control is used.<sup>20-12</sup> With this arrangement, the squeeze timer closes its circuit to the synchronous panel. When the welding current stops, a signal is given back to the sequence control to let it continue with the hold time.

**9-4. Hold Time.**—While the metal pieces are being welded together, the temperature of the metal between the electrode points is so high that some of the metal melts for an instant. While in this fluid condition, the metal pieces are squeezed or forced together by the pressure of the electrodes. When the welding current stops, the metal is still fluid for a very short time. If electrode pressure is removed before the metal cools enough

to regain its strength, the weld is weakened or cracked. Therefore, for most welding, the electrodes must keep their full pressure on the welded pieces, for as much as a second after the welding current stops. This length of time, between the stopping of welding current and the instant when electrode pressure is removed from the work, is called the *hold time* (not the cool time). When a time-delay relay has measured off, or timed out, the length of this hold time, the relay opens the circuit to the solenoid valve, which removes pressure from the electrodes and lets them separate, thereby releasing the work. That weld is now finished. With some timing controls, the electrodes do not separate until the operator releases his foot switch or button.

**9-5. Off Time.**—If the operator must give a new separate signal to start each weld, then there is no off time. However, many welding machines, especially gun welders, are used to make a series of welds, one after another on the same metal part. These welds are made so close together that the operator cannot open and reclose the signal circuit for each weld. He pushes the switch for the first weld, but desires the welder to make one spot weld after another as long as he keeps this switch closed. Between the end of one weld and the start of the next weld, the electrodes separate for part of a second to let the operator move the electrodes or work to a new spot. The length of time between the separating of the electrodes and the reclosing of the electrodes is called the *off time*. Most timing controls that include a time-delay relay for the off time also include a snap switch that can be set to give nonrepeat operation and permit only single welds.

**9-6. Time Lengths in Automatic Weld Timer.**—Each of the times mentioned is probably only part of a second, and many welders make more than a hundred welds a minute. To control such a welder, each part of a weld timer works a hundred times each minute, or perhaps 50,000 times during a day. In such service, moving parts wear and require considerable maintenance. This shows the need for tube-operated timers in sequence controls to get rid of moving parts wherever possible. Electricity does not wear out a wire, and a tube operates many millions of times without service or replacement.

The four times already described—squeeze, weld, hold and off times—are all that are needed for studying the operation of the automatic weld timer in this chapter. There are also the heat

time and cool time, which are described with pulsation welding in Chap. 10.

Three cycles is the shortest time delay for which any one of these circuits should be set. The usual weld time can be set or

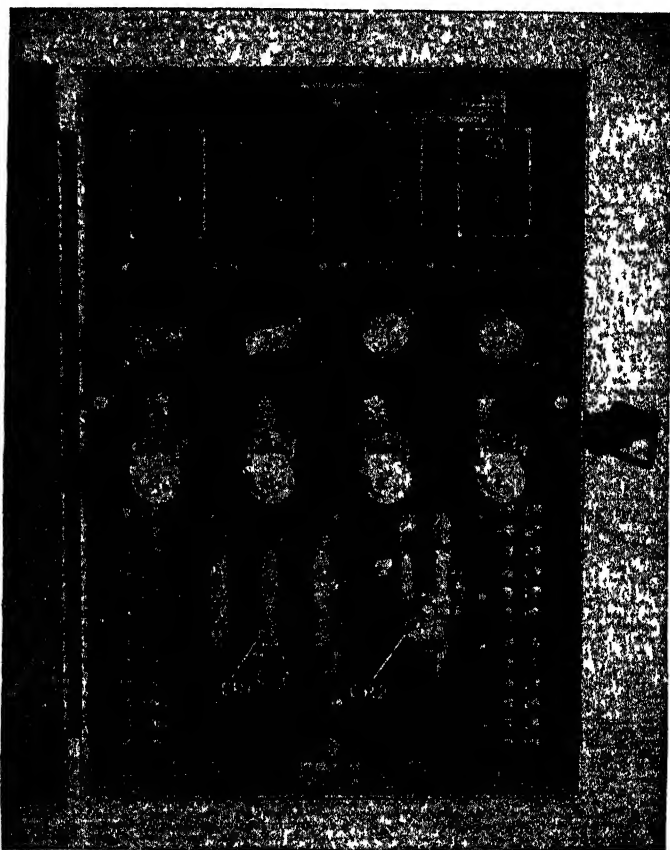

FIG. 9B.—Automatic weld timer (G.E. Type CR7503-F).

adjusted for as long as 30 cycles, while the squeeze, hold and off times can be adjusted to 60 cycles.

**9-7. Time-delay Relays Combined.**—An automatic weld timer giving squeeze, weld, hold and off time can be made by using four time-delay relays like those described in Chap. 7. Several of these need more relay contacts than are included in the standard

time-delay relay. In addition, two instantaneous relays are needed to control the circuit to the solenoid valve of the welder and to control the circuit to the line contactor. The weld timer shown in Fig. 9B includes these four time-delay relay circuits, with all necessary contacts and relays to do the complete job of controlling a spot welder. If the control panel of Fig. 9B is sliced vertically into four parts, each slice contains one complete time-delay circuit, including the tube, the time adjusting potentiometer and the sensitive relay.\* Each of the four circuits has its own resistors and capacitors, but the power for all four circuits is obtained through one transformer, having many separate windings; this permits this timing control to be operated directly from 115-, 230-, 460- or 575-volt a-c supply. The circuit and operation of this automatic weld timer will now be discussed.

**9-8. Diagrams of Automatic Weld Timer (CR7503-F118).—**The wiring or connection diagram of this General Electric weld timer is shown in Fig. 9C, and the corresponding elementary<sup>7-4</sup> diagram is shown in Fig. 9D. As just mentioned, this weld timer includes four time-delay relay circuits. The first entire circuit (at the right-hand side of Fig. 9C), which controls the squeeze time, is called *time-delay relay 1*, or *TD1*. The parts of this circuit are numbered, as tube 1, potentiometer *P1*, timing capacitor *C11* and resistor *R11*, so as to show that all these parts are in circuit 1. Next comes circuit 4, which controls the weld time and includes tube 4, potentiometer *P4*, timing capacitor *C41* and resistor *R41* and other parts, all having numbers whose first digit is 4. (There is no circuit 2 or circuit 3 on this diagram, for these circuit numbers are used for heat time and cool time, which are found in another weld timer in Chap. 10.) Notice that all the parts of circuit 6 are arranged one above the other at the left-hand side of the connection diagram, showing that these parts are found at the left side of this timing panel. But are you looking at the front or at the back of the panel when you say that the parts of circuit 6 are at the left-hand side? In the upper right-hand corner the diagram reads "Back view." Therefore the circuits and parts are shown in their places as they

\* The sensitive relay used in these tube circuits is also called the *telephone relay* because thousands of them are in daily use in telephone switching circuits, where they have proved their ability to operate thousands of times daily.

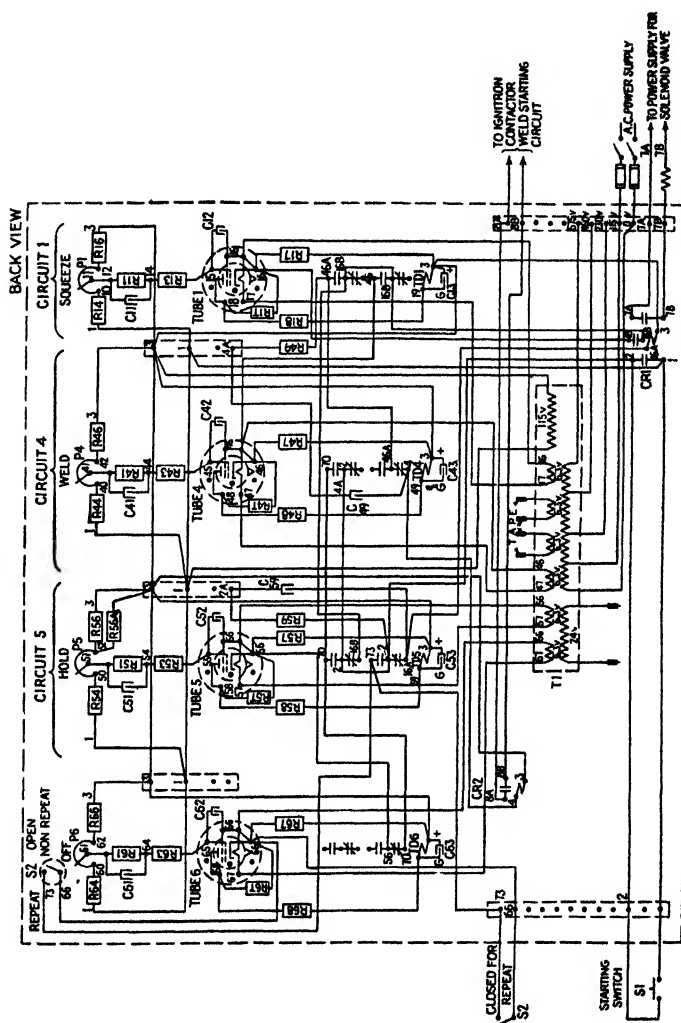

Fig. 9C.—Connection diagram of automatic weld timer (CR7503-F118).



appear when you take the panel out of the enclosing case and look at the back side, where most of the wires and connections can be seen. Seen from the front or tube side, circuit 6 is at the right-hand side and is marked "Off," since it measures the off time. At the top is switch *S2*, which prevents circuit 6 from operating when only single welds or nonrepeat operation are desired.

Circuit 1 of Fig. 9C includes all the parts of a complete time-delay relay, whose operation is described in Chap. 7. Circuit 4 is also a complete time-delay relay. In circuit 4, for example, the resistors *R44* and *R46*, together with time-adjusting potentiometer *P4*, make the voltage divider<sup>7-10</sup> for selecting the voltage for charging the timing capacitor *C41* and for controlling the grid of tube 4. When tube 4 passes current, this current energizes or picks up relay *TD4*, which is just below tube 4. Notice that this sensitive relay has two pairs of contacts, or a total of two normally-open (n-o) and two normally-closed (n-c) contacts. Two of these are not being used. Underneath the *TD4* relay coil, near the bottom of the panel, is located the supply transformer *T1*, which has nine separate windings. The voltage measured across each winding is marked. Four of the 6.3-volt windings supply the filaments or heaters of the four tubes. The 115-volt winding supplies all four voltage dividers, connected in parallel between points 1 and 3. The long winding has five wire connections, so that two wires can be chosen to let this transformer take power from either a 115-volt, a 230-volt, a 460-volt or a 575-volt a-c circuit. Other windings with taped leads are not used in this kind of weld timer panel. (Some plants require a supply of 24 volts a.c. and an extra relay so the push-button circuit can operate at this lower voltage.)

Relay *CR1* (lower right) has three n-o contacts,<sup>8-15</sup> one of which closes the external circuit to the solenoid valve, to make the welder electrodes come together. Relay *CR2* (left of transformer *T1*) has only one n-o contact, which closes the igniter circuit of the ignitron contactor, just like contact 5 in Fig. 3D.

**9-9. Elementary Diagram, Fig. 9D.**—The complete elementary diagram of this automatic weld timer is shown in Fig. 9D. Starting with the supply transformer at the top, notice that the secondary winding of *T1* gives 115 volts between points 1 and 3: Just below *T1* is the user's initiating switch, which is the foot

switch or button that the operator pushes to start the welder. The closing of this switch completes the circuit to the coil of *CR1*, which immediately closes its contact *7A-to-7B* to energize the solenoid valve. The voltage supply to the coil of this solenoid valve should be separate and perhaps different from the voltage supply to transformer *T1*.

In this elementary diagram, each of the four time-delay circuits is merely shown as a rectangle, marked like *TD1* or *TD4*. Each rectangle shows only three connections to the time-delay circuit that it contains. Connections 1 and 3 furnish the 115-volt a-c supply to all these circuit parts, and 16 or 46 is the connection that starts the circuit to give its time-delay action. For example, when the circuit is closed to point 16, then *TD1* starts to time the squeeze time, which is set for perhaps 7 cycles. At the end of this 7 cycles of time, the sensitive relay in circuit 1 operates its contacts. These contacts are not shown inside the rectangle of *TD1*, but are shown farther down in the elementary diagram, in the circuits to *CR2* and to *TD4*. This shows that, when *TD1* times out or operates its relay contacts, one of these *TD1* contacts energizes *CR2* while the other *TD1* contact closes the circuit to point 46, which then starts *TD4* to measure its weld time.

When you need to know the detailed operation of the time-delay circuit inside of one of these rectangles, you will find this circuit in the lower right-hand corner of Fig. 9D. This shows the parts of circuit 4, but it applies just as well to circuit 1 or 5 or 6, all of which are just like circuit 4. Although this circuit is explained in Chap. 7, it is given here also, using the circuit parts shown in Fig. 9D.

**9-10. How Each Time-delay Circuit Works.**—While the starting contact is open (*TD1* is the starting contact for circuit 4), there is no current flowing from 3 through coil *TD4*, *R48* and anode of tube 4, because the cathode 46 is not connected to the other side 1 of the a-c supply. At this same time, current flows from slider 41 through *R41*, *R43*, grid to cathode of tube 4 and through *R47* to 3. Owing to grid rectification,<sup>7-18</sup> this current flows in only one direction and charges capacitor *C41* to the crest value (see Sec. 7-14, footnote) of the voltage across *R41*, which is slightly less than the voltage between slider 41 and point 3. This timing-capacitor *C41* remains charged as long as the starting contact remains open, and keeps the tube grid more

negative than slider 41. When the starting contact is closed, the circuit is completed from 3 through *TD4* coil, tube 4, cathode 46 to point 1, but tube 4 still cannot pass current through this circuit because of the negative voltage bias on the grid of tube 4. However, as the time passes for which the slider of *P4* is adjusted, the charge on capacitor *C41* decreases because of current forced

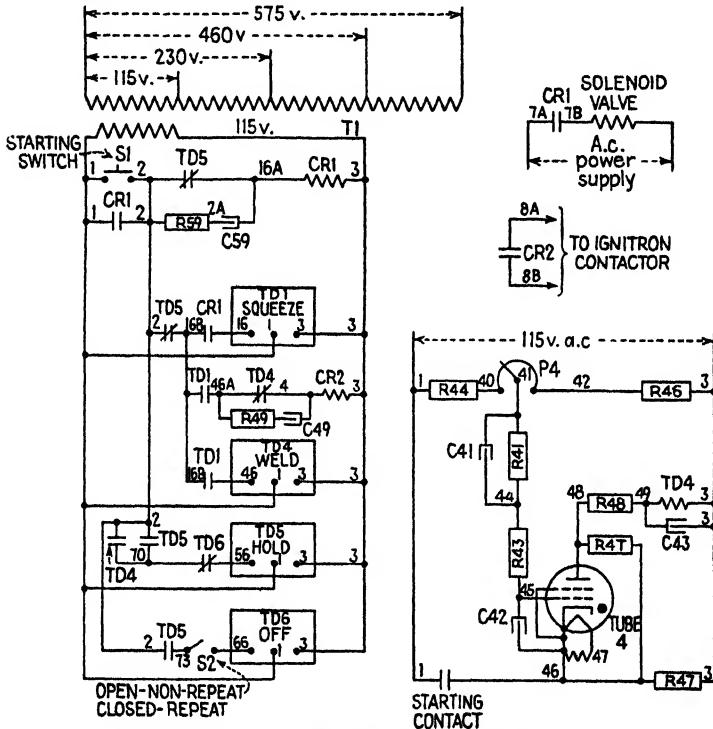

FIG. 9D.—Elementary diagram (CR7503-F118).

through resistor *R41*. Soon this capacitor charge is no longer large enough to keep the grid of tube 4 negative, so tube 4 passes anode current and energizes relay coil *TD4*. This operates the contacts of relay *TD4*, which are shown in the main diagram of Fig. 9B.

The action of the grid circuit is shown in Figs. 7M and 7N. Remember now that tube 4 in this weld timer is a GL-2051

thyatron, while the tube of Chap. 7 is a vacuum tube. When the thyatron is used in this circuit, tube 4 fires instantly and completely, as soon as its grid lets it fire at all. Tube 4 continues to fire and keeps relay *TD4* energized, until voltage is removed from point 46 by opening the starting contact or some other contact in this circuit between 1 and 46

**9-11. Operation of Sequence.**—To trace the sequence or step-by-step operation of these four time-delay relays, as they control a spot welder, refer to elementary diagram Fig. 9D. All four tubes are heated and ready to work 15 seconds after power is connected to transformer *T1*.

Close initiating switch *S1*, which completes circuit from 1 through n-c (normally-closed) contact of *TD5*, to energize *CR1*. *CR1* picks up the solenoid valve and brings the welder electrodes together. At the same time another *CR1* contact connects 1 and 2, sealing in around *S1*, and keeping *CR1* energized even though *S1* is released. A third *CR1* contact completes circuit to 16 on *TD1* time-delay relay. This lets *TD1* measure out the squeeze time, to make sure that the electrodes have time to squeeze the work with enough pressure. At the end of this squeeze time, *TD1* contacts complete the circuit to contactor *CR2*, which immediately closes the igniter circuit of the ignitron contactor, making the ignitron tubes pass current into the welder. At the same instant, the other *TD1* contact completes the circuit to 46, starting *TD4* to measure out the weld time. At the end of the weld time, *TD4* relay opens its n-c contact between 46A and 4, and this opens the circuit to *CR2*. *CR2* drops out, opening the igniter circuit and stopping current flow through the ignitrons and the welder.

Weld timer *TD4* also closes its contact 2-to-70, which completes circuit 56 and starts *TD5* to measure out the hold time, during which time the electrodes press tightly onto the welded spot even though welding current has already stopped. At the end of this hold time, *TD5* opens its n-c contact between 2 and 16A (near top of Fig. 9D); this deenergizes or drops out *CR1*, which drops out the solenoid valve and lets the welder electrodes separate, releasing the work. Although this also opens the *CR1* contact 1-to-2, the *TD5* relay is still energized through its own *TD5* contact 2-to-70, if the operator still holds *S1* closed. However, if *S2* (bottom of Fig. 9D) is open for nonrepeat welding,

the welder will not work again until the operator releases *S1* and then closes it again. Here *S1* opens the circuit to *TD5*, letting *TD5* drop out and reclose its n-c contact 2-to-16A. When *S1* is again closed by the operator, a new weld sequence is started to make another spot weld.

If *S2* is closed, to give repeat welding, the whole sequence is the same as above, to the time when *TD5* operates its contacts. Now, with *S2* closed, *TD5* not only drops out *CR1*, but another *TD5* contact completes the circuit through *S2* to 66, which starts *TD6* to measure out the off time during which the electrodes are away from the work. Another *TD5* contact seals across 2-to-70 so as to keep *TD5* energized even when *TD4* drops out. (*TD4* is dropped out by the opening of *TD5* n-c contact 2-to-6B.) Of course, there is no circuit to make *TD6* work if the operator is not holding *S1* closed at this time. If *S1* is still closed at the end of the off time, *TD6* operates its one contact, which is n-c, between 70 and 56. This *TD6* contact drops out *TD5*. This lets *TD5* reclose its n-c contact 2-to-16A (near top) and energize the solenoid valve, bringing the electrodes together to start another welding operation. This complete operation will be repeated over and over, as long as the operator keeps *S1* closed. If *S1* is opened while the electrodes are together, the electrodes will not separate until after the usual weld and hold times have passed.

**9-12. Purpose of Capacitors in Timing Control.**—The obvious purpose of capacitor *C11* is to give the time-delay operation in circuit 1 to produce the squeeze time. Similarly, *C41* makes tube 4 keep from firing until the end of the weld time. But each of the four circuits also has other capacitors, such as *C42*, *C43* and *C49*.

Capacitor *C43* is connected across coil *TD4* for the purpose (as explained in Sec. 7-21) of keeping the *TD4* relay from chattering. Capacitor *C49* helps prevent burning or arcing at *TD4* n-c contacts 46A-to-4. As shown in Sec. 7-21, a capacitor connected across such contacts is charged by the current that tries to jump across the contacts, forced by the energy in a contactor coil like *CR2*. To prevent *C49* from discharging again too rapidly when *TD4* contacts reclose, resistor *R49* is used to limit the discharge current.

**9-13. Grid-to-cathode Capacitor.**—All these capacitors may be as large as 0.5 mu f, except C42, which is only 0.001 to 0.005 mu f. Small capacitors like C42 or C52 or C12 are quite generally connected between grid and cathode of thyatron tubes in welder-control circuits. Notice that the operation of the time-delay circuit of Fig. 9D is completely explained without mentioning these small capacitors. They are so small that they do not have any real effect on the tube or circuit so long as the power supply is behaving normally. These little capacitors do a real job of preventing the thyatron from false or unexpected operation, resulting from sudden voltage surges in the electric power system. These grid-to-cathode capacitors are important when two or more thyatrons operate from the same voltage supply. A thyatron tube can be easily tripped or made to pass anode current at the wrong time, because of a sudden flicker of grid voltage lasting less than 1/10,000 sec. Such a sudden change in grid voltage can be by-passed or drained harmlessly away through the tiny grid-to-cathode capacitor.

## CHAPTER 10

### PULSATION WELDING WITH AUTOMATIC WELD TIMER

Most spot welders pass current only once when making one weld. This single impulse of current may flow for only a few cycles or, in welding thicker pieces of metal, the weld current may last for a second or two. In recent years, pieces are being welded from  $\frac{1}{8}$  in. up to several inches thick by a method called *pulsation welding* or *interrupted spot welding*.

**10-1. Purpose of Pulsation Welding.**—Pulsation welding is done with an ordinary spot welder. Instead of making a spot weld with one continuous flow of welding current, the one weld is made with a number of shorter impulses of current, separated by short periods when no current flows. For example, several pieces of steel  $\frac{1}{2}$  in. thick are spot-welded together by bringing the electrodes onto the work, then passing about 12 separate impulses of current, each impulse 10 cycles long, separated by 9 cycles of no current flow between impulses. All this is done before the electrodes are separated, and all this makes just one spot weld. This same weld can probably be made also by passing current steadily for several seconds, but this causes too much heating of the electrodes and shortens the electrode life. Welding current must flow through these  $\frac{1}{2}$ -in. pieces for several seconds before this current can produce enough heat in the pieces to melt and join them together. If this current flows steadily, it also produces such high temperature where the electrodes touch the steel pieces that the electrodes soften and “mushroom,” and press deep into the hot steel-surface.

When the pulsation method is used, the welding current must still flow for a total of several seconds or more, but it is divided into many current impulses, each of which produces part of the heat between the inside surfaces of the  $\frac{1}{2}$ -in. pieces. Between impulses this heat cannot escape easily from between the two pieces, so the heat accumulates. Only after several impulses does this joint between pieces become very hot, and it does not

reach welding heat until the eight or ninth current impulse. Meanwhile, each current impulse also produces heat between the electrodes and the work. This heat is removed by the water-cooled electrodes during the time when no current flows or between impulses. Pulsation welding produces as much heat under the electrodes as steady current produces, but this heat is removed almost as soon as it is produced, so the electrodes remain cool. They also keep the outer surfaces of the steel pieces cool under the electrodes, so neither the electrodes nor the steel under them gets hot or soft enough to change shape.

Pulsation welding produces a large amount of heat, a little at each impulse, just as a riveting hammer gives a dozen blows, instead of trying to shape the rivet with one terrific impact.

**10-2. Automatic Weld Timer for Pulsation Welding.**—A spot welder will make a pulsation weld when the proper weld timer is used with the contactor or when the proper sequence control and accurate synchronous control are used together to handle the welder current. For use with an ignitron contactor, the weld timer for pulsation welding is much like the equipment in Sec. 9-8 except that six time-delay circuits are needed instead of four. The two additional circuits control the heat time and the cool

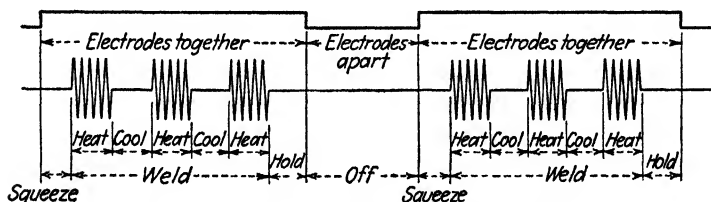

FIG. 10A.—Operations during pulsation welds.

time. Figure 10A shows how welding current flows in pulses while a pulsation weld is being made. Two complete welds are shown. Each weld is made by three impulses of current, which flows for 5 cycles during each impulse. Current stops for 6 cycles between impulses. After the third impulse the weld is finished, but electrodes still apply pressure during the hold time, and then separate for the off time before starting the next weld.

**10-3. Heat Time, Cool Time and Weld Interval.**—As shown in Fig. 10A, the heat-time circuit of the automatic weld timer adjusts or controls the length of each current impulse. During



the heat time the ignitron tubes are passing current to the welder. The cool-time circuit controls the time between current impulses of the same weld. During cool time the ignitron tubes are not passing current. The length of the heat time or the cool time is usually between 3 and 30 cycles long.

In a pulsation weld, the length of one current impulse is not the weld time or weld interval. The weld interval is the total length of time from the start of the first impulse to the end of the last cycle of the last impulse. The weld interval includes all the time while current flows and also all the cool time between impulses. The adjusting knob in the weld-interval circuit is turned so as to get the desired number of current impulses. For example, in Fig. 10A, three impulses of 5 cycles each added to two cool times of 6 cycles each gives a total of 27 cycles, which is therefore the weld interval. If you want to increase to five impulses, keeping the length of each heat and cool time unchanged, the weld interval must be increased to

$$(5 \text{ cycles} \times 5) + (6 \text{ cycles} \times 4) = 49.$$

With the weld interval set at 49 cycles and heat time at 8 cycles (cool time still at 6 cycles), four impulses are then obtained, for  $\frac{49 \text{ cycles}}{8 \text{ cycles} + 6 \text{ cycles}} = \frac{49}{14} = 3\frac{1}{2}$ . This  $3\frac{1}{2}$  means three impulses and the start of the fourth impulse. As shown later, when any current impulse is started, the weld-interval timer always completes that impulse, even if the weld interval finishes immediately after the start of that impulse. Therefore, even if the weld interval is reduced to 43 cycles, then  $43/14$  is still greater than three impulses, so four complete impulses are given by this weld timer.

**10-4. Elementary Diagram, Fig. 10B.**—The connection diagram of this weld timer for pulsation welding is not included because it is so much like Fig. 9C, except that it has six time-delay circuits instead of four. However, the elementary diagram for pulsation welding with an ignitron contactor is shown in Fig. 10B. Many of the parts of this circuit have already been explained (see Secs. 9-9 to 9-13). The squeeze, weld, hold and off timers work the same as in Fig. 9D. When the operator closes the initiating switch (foot switch or button), this energizes CR1, which picks up the solenoid valve and makes the electrodes

come together on the work. CR1 seals itself in and starts TD1 timing.

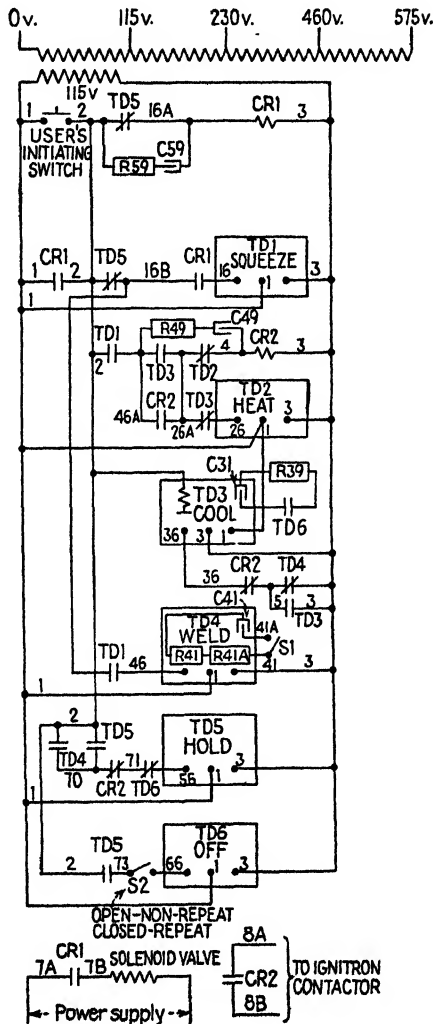

FIG. 10B.—Automatic weld timer for pulsation welding (CR7503-F120).

Notice here that the initiating switch also completes the circuit to the coil shown inside the rectangle of TD3 cool-time relay. Notice also that the power supply to TD3 is reversed, that is, the

connections from lines 1 and 3 go to the terminals on *TD3* opposite to those on other relays. Also, the circuit to terminal 36 is already completed through the normally closed (n-c)<sup>8-15</sup> contacts of *CR2* and *TD4*. This *TD3* relay operates its contacts immediately when the initiating switch closes. This is explained further in Sec. 10-6.

When *TD1* finishes its squeeze time, one *TD1* contact completes the circuit to 46, to start *TD4* to measure the weld interval. At the same time, *TD1* contact 2-to-46A completes the circuit to contactor *CR2*, through *TD2* n-c contact 26A-to-4, and *TD3* contact 46A-to-26A. As just mentioned, *TD3* has already operated its contacts. *CR2* picks up, closing the igniter circuit of the ignitron contactor, which passes current to the welder. *CR2* seals itself in, 46A-to-26A, but opens the *CR2* n-c contact 36-to-5, which deenergizes *TD3*. As *TD3* drops out, its n-c contact completes the circuit from 26A to 26, which starts *TD2* to measure the heat time. These circuits work so fast that *TD2* starts timing at almost the same instant that *CR2* fires the ignitron tubes. When *TD2* finishes timing, its contact 26A-to-4 drops out *CR2*, and this ends the first impulse of welding current.

As *CR2* drops out, its n-c contacts reclose the circuit 36-to-5, which starts the *TD3* time delay in the normal way. While *TD3* is going through its time-delay operation, there is no flow of welding current, so this is the cool time between impulses of current. As soon as *TD3* finishes timing, the *TD3* n-c contact 26A-to-26 opens, which resets or drops out *TD2*. *TD3* contact 46A-to-26A recloses and *TD2* n-c contact 26A-to-4 recloses, again energizing *CR2* to start the second impulse of welding current. As *CR2* picks up, it again opens its contact 36-to-5, which resets *TD3*. In this way *TD2* and *TD3* continue to operate, giving alternate heat and cool times, until their operation is stopped by *TD4*, which has been timing the weld interval ever since *TD1* closed the circuit to 46. *TD4* brings the weld interval to an end by opening *TD4* n-c contact 5-to-3. Since this 5-to-3 contact is in the same circuit with *CR2* n-c contact 36-to-5, this *TD4* contact has no effect, except when *CR2* is deenergized, which is during a cool time. When this *TD4* contact opens, it does not interrupt any welding current or heat impulse, but it does prevent *TD3* from timing out another cool time or from letting *CR2* fire the ignitron contactor again.

When *TD4* times out its weld interval, it brings this whole group of heat and cool times to an end. The weld is now finished, so *TD4* closes its 2-to-70 contact in the circuit to *TD5*. Notice that *TD5* does not start measuring its hold time until *CR2* has dropped out and closed its n-c contact 70-to-71. From here on, *TD5* and *TD6* measure the hold and off times, as already explained in Sec. 9-11.

**10-5. Two Time Ranges in Weld-interval Relay.**—The time-delay circuits represented by each of the rectangles in Fig. 10*B* are the same as shown in Fig. 9*D* and already explained.<sup>9-9</sup>

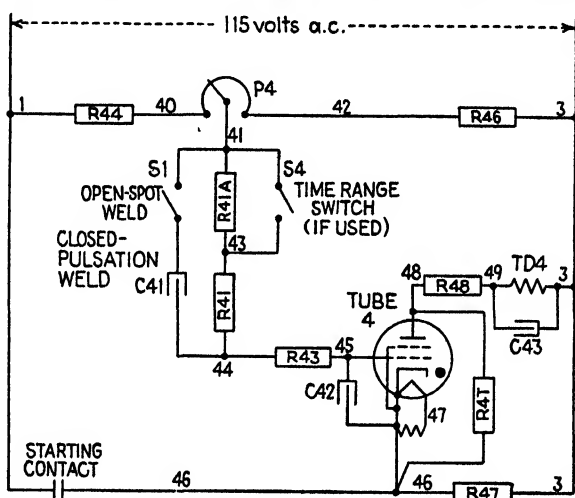

FIG. 10C.—Weld-timer circuit, with switches.

However, two switches are added in the time-delay circuit of *TD4* weld-interval relay, which is shown in Fig. 10*C*. When switch *S4* is closed, the potentiometer *P4* can adjust the weld interval in the range between 9 cycles and 180 cycles. With *S4* open, the range is doubled, or from 18 to 360 cycles. When switch *S1* is opened, there is no time delay at all, so *TD4* operates immediately, to prevent more than one impulse of welding current. With *S1* open, this weld timer produces a spot weld of one impulse, instead of a pulsation weld. The explanation follows:

The time-delay circuit of Fig. 10*C* is the same as Fig. 9*D*, except for the tube grid circuit from the slider of *P4* to the grid 45. With *S1* closed, the timing capacitor *C41* is connected across two

equal resistors,  $R_{41}$  and  $R_{41A}$ . However, if  $S_4$  is closed, then  $R_{41A}$  is short-circuited, and has no effect. Timing capacitor  $C_{41}$  is charged while the starting contact is open, as previously explained,<sup>9-9</sup> but begins to lose this charge as soon as the starting contact is closed. Suppose  $P_4$  is set so that it requires 2 sec. for  $C_{41}$  to discharge through  $R_{41}$  to a low enough voltage to let tube 4 fire. With this same setting, if  $S_4$  is now opened,  $C_{41}$  charges as before, but  $C_{41}$  must now discharge through the combined resistance of  $R_{41}$  and  $R_{41A}$ , which is twice the resistance of  $R_{41}$  alone.  $C_{41}$  now requires twice as long to discharge through this doubled resistance,<sup>7-16</sup> so it takes 4 sec. for  $C_{41}$  to discharge to a low enough voltage to let tube 4 fire. The addition of  $R_{41A}$  and  $S_4$  doubles the range through which the weld interval can be adjusted without making  $P_4$  any more difficult to set.

When switch  $S_1$  is open, timing capacitor  $C_{41}$  cannot be charged, and cannot maintain a negative voltage at the grid of tube 4 when the starting contact closes and completes the circuit through the tube. Therefore, in Fig. 10B, when  $TD_1$  closes its contacts to energize  $CR_2$  and also  $TD_4$ ,  $CR_2$  immediately starts the flow of welding current and  $TD_4$  immediately opens  $TD_4$  n-c contact 5-to-3. The n-c contact 36-to-5 of  $CR_2$  has already reset or deenergized  $TD_3$ . There is no longer any circuit between 5 and 3, so there is no circuit from 3 to 36, even when  $CR_2$  drops out at the end of the first impulse of welding current. Since  $TD_3$  cannot time out, it cannot pick up  $CR_2$  again to start another current impulse. The whole weld now consists of only one impulse and is just a standard spot weld.

**10-6. Reverse Connection of Cool-time Relay.**—As mentioned in Sec. 10-4, Fig. 10B shows that  $TD_3$  cool-time relay has its supply connections reversed, so that line 1 goes to that terminal which is usually connected to line 3, and line 3 goes to the terminal usually connected to line 1. This is done so that  $TD_3$  will have completed its first timing operation and will be ready to operate its contacts immediately when the operator closes the initiating switch. This arrangement also prevents tube 3 from passing current until it has warmed enough. As shown in *a* of Fig. 10D, this same result can be obtained with  $TD_3$  connected in the normal way like  $TD_1$ , but this requires an extra  $CR_1$  contact. Since the circuit is completed to 36 from the very start, the  $C_{31}$

timing capacitor is already discharged, and tube 3 is ready to fire just as soon as the extra *CR1* contact connects *TD3* coil to 3. Instead of using an extra *CR1* contact, the *TD3* relay is started by the *CR1* contact 1-to-2 already being used. To be able to apply potential to the *TD3* coil from line 1 instead of from line 3, it is necessary to reverse the polarity of all the other connections to *TD3*, as shown in *b* of Fig. 10*D*.

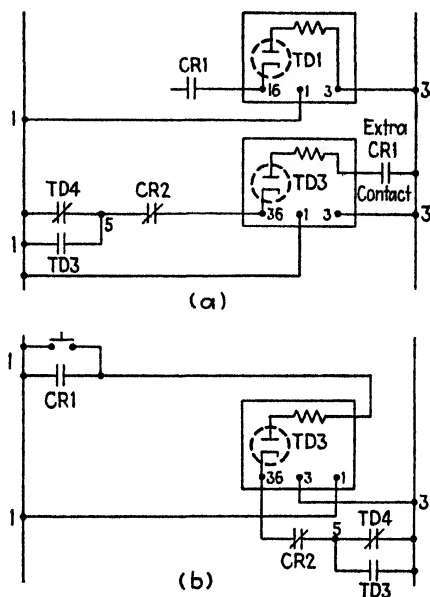

FIG. 10*D*.—Operation of cool-time relay.

**10-7. Cautions Concerning Pulsation Welding.**—The use of an automatic weld timer with an ignitron contactor to make a pulsation weld is generally successful where each heat or cool time is longer than 6 to 10 cycles. However, a cool time less than 6 to 10 cycles may give trouble, for one welded piece may not have the same strength as the next piece welded on the same machine. This trouble results from lack of sufficient accuracy of control of the ignitron tubes, and the usual cure is to add synchronous timing described in Chap. 15. A pulsation weld made by short fast impulses (with each heat or cool time less than 5 cycles long) should not be attempted except with more accurate control, including synchronous timing.

In selecting ignitron tubes for a pulsation welding load, the per cent duty is often found to be very large. The welder may be using welding current for a total of only 10 sec during a minute, but this current may flow for 5 sec during the tube averaging time (such as 7 or 9 sec). This is more than 50 per cent duty.

Great care is needed in attempting pulsation welding of a projection weld. The projections may be squeezed flat during the first or second current impulse, causing such increased contact area between pieces that proper welding heat cannot be produced by later impulses. Unless synchronous timing is used, one of these early current impulses may be abnormally high, overheating the projection and causing it to flatten more quickly than usual.

Although each impulse of a pulsation weld may draw less current and cause less voltage drop than in the case of the same weld made with one longer flow of current, yet the visible light flicker produced by such momentary drops in voltage may be more noticeable when caused by the pulsation weld because of its more frequent recurrence.

## CHAPTER 11

### THE WELTRONIC WELD TIMER

The weld timers of previous chapters have shown circuits used by the General Electric Company. It is of interest to see how similar controls are designed by another manufacturer (Weltronic Corp.). The automatic weld timer described below controls four separate time periods. Either this Weltronic timer or the G.E. timer of Fig. 9D makes a spot welder operate in the same way.

**11-1. Arrangement of Weltronic Timer.**—This type of timer is a grouping of a number of tube time-delay relays. As will be seen later, one of these time-delay circuits, using only a single tube, sometimes controls two separate time-delay periods. Only three tubes are needed to control the squeeze, weld, hold and off times. Vacuum tubes are used, each having a protecting fuse in its anode circuit. Many transformers, each having only two windings, provide the anode and grid voltages. The time-delay periods are changed by switching capacitors into or out of the grid circuits.

The elementary or schematic diagram of this complete weld timer is shown later in Fig. 11D. Just one tube circuit is shown separately in Fig. 11C.

Each tube circuit of this timer usually includes one tube, three separate transformers, a magnetic relay and a variable group of capacitors. These capacitors, with their discharge resistor and tap switch, are mounted together in one can. Referring to Fig. 11C, notice that the tube is in a circuit, 2-to-3 and 7-to-9, which does not touch or connect to the power-supply circuit 5-to-6. The only way that electricity enters the tube circuit is through one of the transformers. Transformers *T4* and *T5* supply grid voltages, and *T3* furnishes the anode voltage necessary to force current through tube 2 and relay coil *CR2*.

**11-2. Transformer Connections.**—The purpose of a transformer is to change one voltage to another voltage, or to change one current to another amount of current. The transformer



works only on a.c., or on a change of voltage or current. Every transformer has two or more windings, and there is no metal-to-metal connection from one winding to another winding. (An autotransformer has only one winding with taps.) Electricity is transferred from one winding to another winding because of magnetic changes produced in the iron core of the transformer.<sup>20-6</sup>

A winding that takes power into the transformer from an electric supply is called the *primary winding*. Any winding that gives out power from the transformer, to operate something else, is called a *secondary winding*.\* In Fig. 11C the three trans-

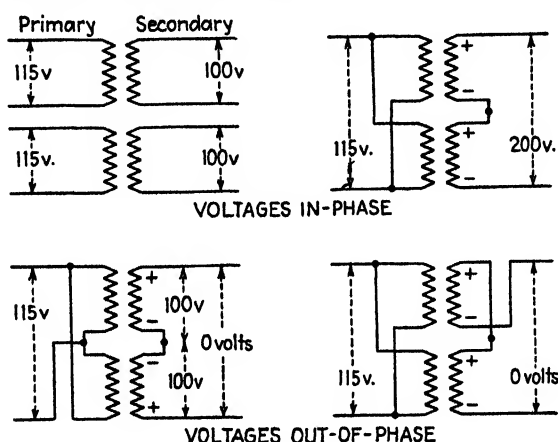

FIG. 11A.—Transformer-winding combinations.

former windings connected to points 4, 5 or 6 are primary windings, for they all receive power from the 115-volt supply. When the primary winding is not energized, no voltage is produced in the secondary winding of that transformer.

An ordinary voltmeter or light or solenoid will work just the same whether the two wires connected to it are reversed or not. As a result, some people think that it is not important which way a pair of wires is connected in an a-c circuit. In tube circuits it is very necessary to connect the two wires properly for the circuit will work in a different way, or not at all, if these two

\* Since distribution transformers are more often used to reduce or "step down" the voltage, the output or secondary winding is more often the lower voltage winding. However, as used in welder controls, the secondary winding often supplies higher voltage than the primary input voltage.

wires become reversed. An oscilloscope<sup>6-7</sup> quickly shows the difference when a-c wires are reversed, as shown in Fig. 11B.

**11-3. In Phase or Out of Phase.**—To understand how the grid circuit in Fig. 11C works, first study the connection of transformers operating in phase and out of phase. In the weld-timer circuit, the windings of transformers *T4* and *T5* are connected together. Figure 11A shows these two transformers connected in various ways. Across each secondary winding alone, a voltmeter measures 100 volts a.c. When the transformers are connected in phase, the two secondary voltages add together, so that a voltmeter measures 200 volts across the two secondaries

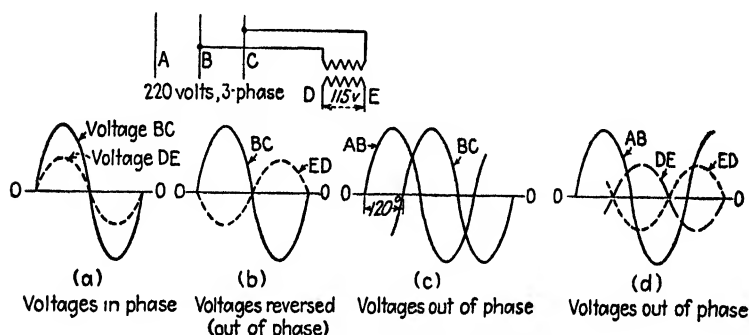

FIG. 11B.—Voltage-phase relations.

in series. If the two leads of one of the primaries (or one of the secondaries) are reversed, the secondaries become completely out of phase, so that the voltage across one secondary opposes or bucks the voltage across the other secondary. A voltmeter still measures 100 volts across each secondary alone, but measures zero or no voltage across the two secondaries in series. This is the connection used in the tube circuit of Fig. 11C.

Two voltages are in phase with each other when their wave pictures (as shown on an oscilloscope<sup>6-7</sup>) cross the 0-0 line at the same point, and both go from below the line to above the line together. Figure 11B shows the three wires of a three-phase power supply, and the two wires *DE* connected through a transformer to the *BC* phase. If the scope leads are touched first to *BC* and then to *DE*, the two waves will cross the 0-0 line at the same point, but may be in phase (a) or exactly out of phase (b), showing whether the connections are reversed or not. The

voltages on two different phases of a three-phase circuit can never be in phase with each other. If the scope leads are touched to line *AB* and then to line *BC*, the two waves may have the same size and shape but will cross the 0-0 line at different places.

**11-4. Single Tube Circuit.**—In Fig. 11C, when the starting contact is open, there is no voltage across the primary winding (4-to-6) of transformer *T3*; therefore there is no secondary voltage between 1 and 3. There is no electrical pressure in the tube circuit, so there is no voltage that can energize *CR2*. However, while the starting contact is open, things are happening

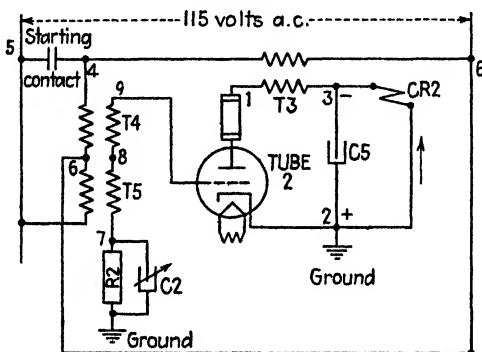

FIG. 11C.—Single tube circuit of Weltronic timer.

in the tube grid circuit. The primary of transformer *T5* is always energized, being connected from 5 to 6. The secondary of *T5* produces about 100 volts a.c. At the same time, transformer *T4* is “dead,” or furnishes no voltage, since its terminal 4 is not connected to 5. When there is no voltage between 8 and 9, the grid circuit works as though *T4* were short-circuited by a wire connected from 8 to 9. Through this grid circuit, the 100 volt pressure from *T5* can force a very small current, which flows into the grid of tube 2, to the cathode 2, into ground,\* and from the other ground connection into *R2* and back to terminal 7 of *T5*. Except for a few volts drop between the tube grid

\* Wherever two parts of a circuit are both shown connected to ground (symbol  $\text{⏏}$ ), then these two parts are really connected together. In Fig. 11C point 2 is grounded to the metal case, and the bottom of *R2* is also grounded to the case. Therefore these two points are electrically together, just as if a wire connected 2 to the bottom of *R2*. These grounded parts are also connected to any other grounds.

and cathode, almost all of this 100 volts a.c. appears across *R2*. Capacitor *C2* is charged to the crest<sup>7-14</sup> of this a-c voltage across *R2*, or about 130 volts. Since current flows out of *R2* at 7, then 7 is 130 volts more negative than the ground side of *R2*. Capacitor *C2* keeps point 7 more negative than cathode 2, so the grid of tube 2 is held 130 volts negative.

When the starting contact is closed, transformer *T3* produces anode voltage which tries to force current through tube 2. However, the 130-volt negative bias on the grid of tube 2 prevents passage of anode current. Closing the starting contact also energizes *T4*, whose secondary now produces 100 volts, which is out of phase or opposed to the voltage of *T5* secondary. Since the total voltage between 7 and 9 is now zero, capacitor *C2* does not receive any fresh charge, but instead *C2* starts to discharge through *R2*. When the charge on *C2* decreases to a low enough value, the grid voltage of tube 2 becomes close enough to the tube's cathode voltage to let tube 2 fire or pass current to pick up relay *CR2*.

The time delay of this circuit depends on the time needed for *C2* to discharge through *R2*. To change the time delay, *R2* remains unchanged but the size of capacitor *C2* can be changed in 10 equal steps. *C2* consists of 10 small capacitors, with a dial switch to connect any number of them in circuit. With all 10 capacitors connected in circuit, the longest time delay is obtained. With two capacitors in circuit, only these two have to discharge through *R2*, requiring shorter time.

Across the *CR2* coil is capacitor *C5*, which is charged during the half-cycles when current flows through tube 2. When tube anode current stops (during the negative half-cycles), *C5* discharges and keeps current flowing through *CR2*. How long this current will flow depends on the size of *C5*. In the circuits of tube 2 (squeeze time) and tube 3 (weld time) this capacitor is only large enough to pass current for a half-cycle, or enough to keep the relay from chattering. However, in the circuit of tube 1, a much larger capacitor *C4* is connected across coil *CR1*. When tube 1 stops passing current, relay *CR1* does not drop out at once, because *C4* is large enough to supply the hold-in current for *CR1* for quite a few cycles. This number of cycles (hold time) can be increased by turning the dial, which connects more of the parts of capacitor *C4* into circuit.

**11-5. Sequence of Operation.**—The complete diagram of Fig. 11D may now be used to trace the whole operation of this Weltronic weld timer. Notice that the whole circuit operates from 115 volts a.c. To use this control on other supply voltages, different transformers are substituted.

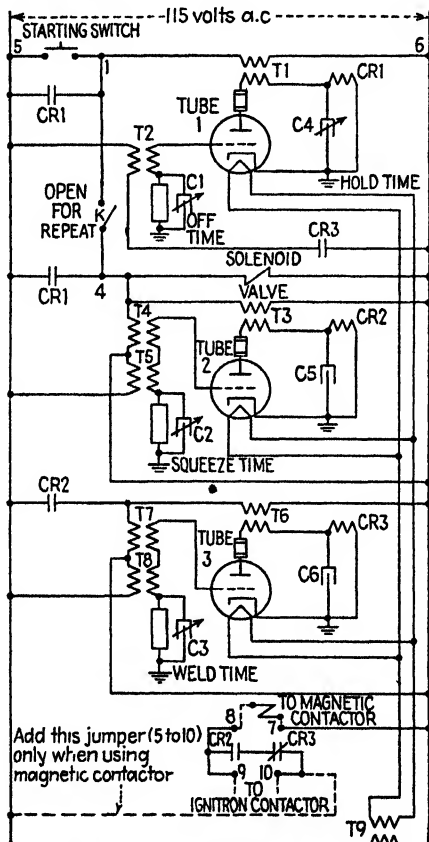

FIG. 11D.—Elementary diagram of a Weltronic automatic weld timer (Model 75).

Closing the starting switch completes the circuit to the primary of  $T_1$ , whose secondary furnishes anode voltage for tube 1. At this time grid transformer  $T_2$  is not energized, so  $C_1$  is not charged. Since there is no grid bias, tube 1 passes current immediately, picking up relay  $CR_1$ , which closes its own holding circuit so that the starting switch may be released.  $CR_1$  ener-

gizes the solenoid valve coil to bring the welder electrodes together. This same *CR1* contact is the starting contact for the squeeze-time circuit already described above. Energizing *T4* permits *C2* to discharge, measuring the squeeze time, before tube 2 fires.

Tube 2 energizes relay *CR2*, which starts the welding current by closing *CR2* contact near the bottom of Fig. 11D. Notice that this weld timer is arranged for use with either a magnetic contactor (coil connected 7-to-8) or an ignitron contactor (igniter circuit connected 9-to-10). *CR2* also energizes transformers *T6* and *T7*, which start the time-delay action in the grid circuit of tube 3. Since *T7* opposes *T8*, capacitor *C3* can discharge through *R3*, measuring the weld time. When tube 3 fires, it energizes relay *CR3*, whose contact ends the weld, by opening the igniter circuit 9-to-10.

In the tube 1 circuit, a *CR3* contact now energizes grid transformer *T2*, whose 100-volt secondary immediately charges capacitor *C1*, thereby placing a negative voltage on the grid of tube 1. Since anode current through these vacuum tubes can be either started or stopped by grid control, this negative grid bias makes tube 1 stop passing current. However, as described above, capacitor *C4* is so large that its charge still holds relay *CR1* closed during the hold time. When *C4* has discharged to a low enough voltage to let *CR1* drop out, *CR1* opens the solenoid-valve circuit, letting the electrodes separate, and the weld is finished. If switch *K* is closed for single weld, the operator must release the starting switch before the relays will reset. If switch *K* is open for repeat weld and the starting switch is held closed, the opening of *CR1* contact 5-to-4 at the end of the first weld opens the circuit to *T3*, which drops out *CR2*. This opens the circuit to *T6*, which drops out *CR3*. Contact *CR3* opens the circuit to *T2*, but tube 1 is still kept from firing again by the negative grid voltage remaining across *C1*. Tube 1 will fire again as soon as *C1* has discharged, measuring the off time. Tube 1 then picks up relay *CR1* again, and the solenoid valve brings the electrodes onto the work to make another weld. Notice that the grid circuit of tube 1 measures the off time, while the anode circuit of the same tube measures the hold time. A change of either time setting will not affect the other time.

There are many kinds of Weltronic weld timer but they usually include circuits similar to those just described.

## CHAPTER 12

### MAINTENANCE AND "TROUBLE SHOOTING" ON WELD TIMERS AND SEQUENCE CONTROLS

The automatic weld timers described in preceding chapters are made of a number of tube time-delay circuits. Sequence\* controls have the same circuits except that no relay is included for the weld time or heat time. The suggestions for servicing these controls will also apply to the individual time-delay relays of Chap. 7. Such suggestions should first include a comment on the proper power supply for operating these controls.

**12-1. Voltage Supply for Weld Timer.**—Although the weld timer or sequence control is used with a welding machine, this control does not have to operate from the same wires that supply the welder. A different supply for such controls is often better. Any voltage from 110 to 600 volts a.c. can be used, and may be taken from a phase different from the phase supplying the welder. The best power supply for the weld timer is that line which has the steadiest voltage, free from dips and surges. Since the cables to the welder will have to carry large currents during each weld, there is often so much voltage drop during the weld that these cables cannot be used successfully to supply the small amount of power for the weld timer. Most difficulties with these timing circuits are caused by voltage changes. When any weld timer gives trouble (especially on new jobs), always be sure the supply voltage is steady before checking into the equipment. A 10 per cent change in voltage may make the relays chatter or may change the timing.

In dozens of new installations the weld timer works well at first, but stutters or repeats as soon as heavier welds are tried because of the greater voltage dips resulting. This trouble disappears when the weld timer is connected to a lighting circuit or to another power feeder free of voltage dips. If there is no

\* Sequence timers, specially designed for use with synchronous timing panels, are described in Chap. 20. More service suggestions, applying mainly to those controls, are given in Sec. 20-15.

steady voltage supply at that place, a small constant-voltage transformer (250 va, 115 volts) may be used to smooth the supply to the weld timer alone. The voltage dip may not be caused by the power feeder, but may result from loads suddenly added to the small wires leading to the weld timer. For example, if the welder solenoid valve takes its power from the same leads as the weld timer, the sudden inrush of solenoid current may dip the voltage at the control, making one of the relays vibrate or repeat.

**12-2. Where to Look for Trouble.**—Since a weld timer includes several tube-control circuits and many relay contacts, the quickest way to locate trouble is, of course, to find out in which section of the control the trouble appears. Knowing the proper sequence of the several time-delay circuits (as explained in Secs. 9-11, 10-4 and 11-5) or having seen and learned which tubes or relays usually operate first, second or last, then it is easy to tell which tube circuits work all right and which operate differently from usual. The control may work for part of the way and then always stall at the same point, indicating that some contact is not closing properly. If the trouble occurs in one tube circuit, any part of that one circuit may be at fault, starting with the tube itself. The troubles that are hardest to locate are those which cause erratic timing or change the length of time delay during several repeated operations.

Before working around a weld timer, be sure that the welder operator is not where he can be hurt if the electrodes suddenly come together. With power still connected to the weld timer, examine the tubes, replacing any tube that is cold, perhaps from having an open filament. Although the tubes may appear to be normal, interchange them in the sockets to see if this makes any change in operation. Replace any tube that causes unusual operation in any circuit. If one of the small relays fails to pick up or operate its contacts, carefully push this relay in, to see if the rest of the sequence continues normally. If this relay is the "bottleneck," examine all contacts through which this relay coil is usually energized.

For example, in Fig. 12A (which is part of the weld-timer circuit of Fig. 9D), suppose contactor *CR2* does not pick up, but *TD1* does time out as shown by the blue glow in tube 1. The whole circuit to the coil of *CR2* is traced from 1, through *CR1* contact to 2, through *TD5* n-c contact to 16B,



through *TD1* contact to 46A, through *TD4* n-c contact to 4 and through *CR2* coil to 3. Since *TD1* works, the circuit is all right from 1 to 16B. The trouble with *CR2* may therefore be in the *TD1* n-o contact or the *TD4* n-c contact. The n-c contact is more likely to give trouble. In Fig. 9C, this n-c contact on *TD4* relay is the contact closest to *TD4* coil. The contact on *CR1* is the one farthest from the *CR1* coil.

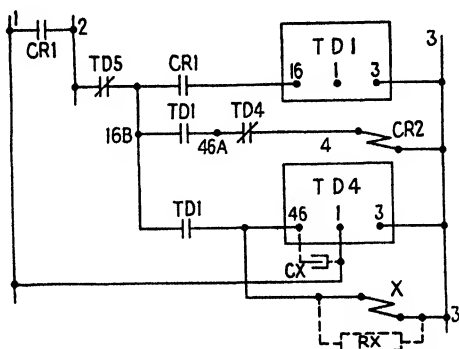

FIG. 12A.—Correcting external loads controlled by timer contacts.

Such a contact on some other relay may be dirty, pitted or not moving far enough to close its circuit. Often a good voltmeter or scope must be connected across such a contact to make sure that it is completing the circuit. Greater contact movement or pressure may be necessary. To clean contacts, use a fine file or burnishing tool. Do not use sandpaper, which may leave fine particles wedged in the contacts.

Where a separate pressure switch works together with the weld timer to start the flow of welding current, a poor setting or adjustment of either control can cause faulty timing. For example, if the weld timer includes a squeeze timer and the welder also uses a pressure switch (in series with the *TD1* contact that starts the weld) to make sure that the electrodes are squeezing tightly, then trouble occurs whenever the pressure switch closes later than the end of the squeeze-timer setting. If the weld time is set for a 3-cycle weld, then the weld is truly 3 cycles long only when the pressure switch closes before the squeeze time ends. Suppose the squeeze timer operates after 5 cycles, but the pressure switch does not close until 2 cycles later; then 2 cycles of the weld time has already passed by before the pressure switch starts the flow of welding current. Current now flows only 1 cycle before the weld timer stops it. If the pressure

switch closes 1 cycle still later, one or both ignitrons may not fire at all, giving the impression that the ignitrons are at fault. A scope or cycle recorder connected across the n-o contact in the igniter circuit will quickly show what is happening.

When installing a weld timer or sequence control, be sure that the mounting bolts or conduit connections do not touch live parts of the equipment.

**12-3. Vibrating Relay or Repeating Operation.**—As mentioned in Sec. 12-1, a vibrating or repeating relay is usually caused by a voltage dip, so the voltage supply to the weld timer should be checked and improved. Where a relay vibrates all the time it is energized, check the capacitor connected across that relay coil.<sup>7-21</sup> Temporarily connect another capacitor (0.5 mu f or larger) across the relay coil. If the chattering then stops, the original capacitor is probably open-circuited and must be replaced.

**12-4. Erratic Timing, Wrong Time Delay.**—The weld timer may not be at fault, and yet it may give erratic or changed timing, because of the following things.

1. Voltage surges in supply circuit.
2. Other equipment connected and operated by the same contacts that start the time-delay operations.
3. Time-relay circuits are deenergized less than 3 to 5 cycles between operations (see Sec. 12-5).
4. Large changes in temperature at the control (see Sec. 12-6).
5. Tubes are not warmed long enough.

Troubles 1 and 2 may be corrected by adding a small capacitor or resistors at the right place. For example, the user of a weld timer like that of Fig. 9D adds and connects a contactor for another purpose, so it is energized by the weld timer at the same time the welder current starts. Figure 12A shows this connection, where *X* is the coil of this added contactor, connected between 46 and 3, so that *X* is energized when the *TD1* contact closes to start the *TD4* weld-time relay. The user now finds that the length of weld time measured by *TD4* is not always the same. In fact, *TD4* relay sometimes closes for just an instant and then reopens for the rest of the weld time. This trouble results from the slightest bouncing of the *TD1* contact.\*

\* As the contact bounces open, a voltage "kicks back" from coil *X*, which affects the sensitive timing circuit of tube 4. The contacts of these

In this certain circuit, this coil *X* would be better connected from 46A to 3. In a circuit where the connection cannot be changed this easily, the trouble can be decreased by connecting a resistor across the added coil, as shown by *RX*. In this 115-volt circuit, *RX* may be about 400 ohms. In a 230-volt circuit, try 1000 ohms.

This trouble and also the circuit surges of (1) above may be decreased by connecting a small capacitor as shown at *CX* (about 0.05 mu f). Also try this 0.05 mu f capacitor connected between line 1 and the metal case of the weld timer.

**12-5. Too Little Time between Operations.**—As described in Sec. 9-10, each tube circuit has a timing capacitor that discharges gradually to give the time-delay action. When the control circuit opens and this relay resets, this capacitor charges up again so as to be ready for its next operation. It cannot charge instantly, for this charging current is limited by resistors in the grid circuit and also depends on the size of the capacitor. As much as 5 cycles may be needed to charge this capacitor fully. In single-spot welding control, this amount of time is easily obtained between spot welds. However, in pulsation welding, the length of the cool time is also the time during which the heat-time capacitor must recharge. Similarly, the cool-time capacitor must recharge during the heat time. Since either heat time or cool time can be adjusted as short as 3 cycles, these capacitors do not fully recharge before their next operation starts. They will work successfully without fully recharging, but do not be surprised if the movement of the cool-time dial also affects the length of the heat time, or the other way around.

**12-6. Operating Temperatures.**—If the weld timer or sequence control is used before its tubes have reached full heat, the timing periods may be changed.

The room temperature around the weld timer has some effect on the length of the time delays. Unless this temperature changes more than 20 or 30 degrees Fahrenheit, the change in time delay is not noticeable.

---

small telephone relays do not bounce so much as ordinary contact tips, yet it should be noticed that this weld timer purposely uses two separate *TD1* contacts so that any bouncing of *TD1* contact 16B-to-46A cannot possibly let *CR2* coil "kick back" and affect the timing circuit of *TD4*.

**12-7. Checking the Time-delay Circuit.**—After the easier things have been tried and the preceding suggestions have given no improvement, the trouble may be found in one of the tube time-delay circuits.

If the time delay cannot be smoothly adjusted by turning the potentiometer knob, the potentiometer probably needs to be replaced. To check, connect a voltmeter from the slider to one end of the potentiometer winding and watch the voltage change as the slider is moved. With power off, this may also be checked with an ohmmeter.

Referring to Fig. 9D, if the time delay cannot be adjusted for any time except the longest time that that relay can give, *P4* may be open near 42 or *R46* is open. If the time delay is always the shortest that that relay can give, *P4* may be open near 40 or *R44* is open. Also, *R47* may be open, or *C41* may be open or shorted. *C42* may be shorted. A good analyzer,<sup>6-3</sup> is best for checking these parts.

If the relay, like *TD4*, does not pick up and a new tube 4 does not help, *C43* may be shorted or *TD4* or *R48* may be open. If *TD4* is continually energized, check *R4T* (measure its resistance).

Aside from seeing that the relay contacts can close and open properly, do not try to change adjustment of parts of the sensitive telephone relays.

**12-8. Checking the Vacuum-tube Time-delay Relay.**—The circuit of the general-purpose tube timer described in Chap. 7 is much like each tube circuit of a weld timer or sequence control. The above suggestions will help locate trouble in the separate tube timer also. Furthermore, the vacuum tube itself makes it possible to check how well the circuit is working. Since it may often be necessary to measure the load or anode current passing through such a vacuum tube, get an adapter (from a radio store) with which to connect a meter into the anode circuit. Plug this adapter into the tube socket, then plug the tube into the adapter. Inside the adapter the tube anode circuit is connected to two wires which come out to be connected to a milliammeter,<sup>6-3</sup> so as to measure the amount of anode current.

The tube anode current measured in this way is also the current flowing through the sensitive telephone relay. This relay usually picks up at about 2.5 milliamperes (0.0025 amperes) and drops out at 1.0 to 2.0 ma. After the time delay, if the measured

current is too small to operate the relay, measure the line voltage to see if it is at least 110 or 220 volts. See whether the relay is connected to the 115-volt terminal or to the 230-volt terminal underneath the relay frame. Watching the milliammeter, see what amount of current picks up the relay. (When relay picks up, a slight flicker of the meter needle is seen.) Measure the resistance of the relay coil, connecting the positive ohmmeter lead to 6B and the negative lead to 12 (Fig. 7C). Such relay coils have 5000 to 7000 ohms resistance. If higher resistance is measured, the coil is probably open or connections are broken. If resistance is below 5000 ohms, either the coil or capacitor C2 is shorted.

**12-9. Spare Parts.**—Where a number of duplicate tube timers or sequence controls are used in the plant, it is wise to have a complete spare timer or control available to let production continue while the fault is found and corrected in the original unit. If spare parts are needed, why not keep them handy on a complete spare control?

The parts of weld timers most likely to need replacement are the tubes, potentiometers and relay contacts. Complete telephone relays may be kept in stock, and it is most advisable to have a spare for each kind of control transformer. The small resistors and capacitors are more quickly obtained from a radio store.

## CHAPTER 13

### GOOD VOLTAGE FOR THE WELDER

Voltage is the electrical pressure that forces line current through the welder transformer or forces welding current through the electrodes to make the weld. If this pressure changes, the amount of current changes and affects the weld. Good voltage for the welder is a voltage supply that stays constant or steady.

**13-1. The Voltage Problem.**—Years ago voltage changes or dips were not considered important. Then welding machines were small and took 8 to 30 cycles of time ( $\frac{1}{2}$  sec) to make each weld. Modern welding includes welders rated 1000 kva or more, which draw momentary loads of several thousand kva. Moreover, to weld certain metals properly, these big welders draw very large current loads for just  $\frac{1}{30}$  sec. The effect of these sudden changes of load is felt far back at the powerhouse where the electricity is made. To understand why these big welders have so much effect, remember that a load of 2000 kva is often as large as the total power needed by a plant employing 1000 men. There may be only one or two such plants taking power from a feeder or substation. One big welder, controlled by a pair of big ignitron tubes, causes larger voltage changes than several manufacturing plants.

The sudden voltage drop or dip caused by a welder will affect the operation of other equipment, and may make the lights flicker every time a weld is made. The voltage change also affects the welder itself and the equipment that controls the welder. Anything done to decrease the amount of this voltage change also improves the weld.

The cause of the voltage drop is not found at just one place. Some loss or change in voltage occurs along every foot of the cable or feeder between the welder and the powerhouse. Much of it may be found in the power transformers. That part of the voltage drop which is measured where the power line enters the plant must usually be remedied or absorbed by the power company. (A power company may have special rates for such

service.) However, most of the voltage drop at the welder is produced in the feeders and transformers owned within the plant. It is up to each plant or user of welders to see that the electric feeders and equipment are selected and installed in such a way that the welders will have a good voltage supply with which to work.

**13-2. Limits of Voltage Changes.**—Large industrial plants try to use transformers and feeders large enough so that the voltage supplied to most equipment will not change more than 10 per cent at any time. If a motor works at 430 volts at heavy load when all parts of the plant are working, then that same motor should not have more than  $430 + 10$  per cent = 473 volts at its terminals when most other equipment is idle. Although this 10 per cent change is all right for power equipment, plant lighting will suffer from such great voltage changes. Lights flicker badly on only 2 or 3 per cent voltage change, so lights are usually operated from separate feeders and transformers.

However, the same feeders that keep voltage changes within 10 per cent at motor terminals can seldom serve resistance welders this well. Many spot welders cause their supply voltage to drop 15 to 25 per cent because they draw such sudden large loads. Because the name-plate current of a 100-kva welder is no greater than the current drawn by a 100-hp motor fully loaded, many plants use the same size of power feeder to connect to either the welder or the motor. If someone suggests starting this motor at full voltage, "across the line," others warn that the motor's large inrush current will "dip" the voltage all along the feeder. They do not realize that the spot welder draws about as much current as is needed to start this motor across the line. Since a 100-kva welder may draw a 300- or 400-kva load during each weld, the feeder cable and transformers must be able to handle these high load peaks without more than 10 per cent voltage drop while the weld is being made. For some recent forms of welding, requiring very accurate control, only 5 per cent change in voltage at the welder can be permitted.

Where many large welders are connected to the same feeder or power supply, the current drawn by just one welder may cause 10 per cent voltage drop. When two welders draw current at the same time, the voltage at both welders drops nearly 20 per cent and neither weld is as good as usual. The chance of three

welders drawing current at the same time is very small. Welding machines have sometimes been interlocked to prevent more than one machine from welding at a time. Such interlocking is not satisfactory for long periods, except in extreme cases where production demands must bow to limited power supply.

This limit of 10 per cent change in voltage should be measured by a fast-reading instrument like an oscilloscope or pointer-stop voltmeter. The large voltage change at welders in many plants is not known or realized without the help of such instruments.

**13-3. How to Reduce Voltage Changes.**—Unless this power and voltage problem is studied and settled before the welding machine is purchased or placed in service, large and costly changes may be necessary. These changes may include (1) new

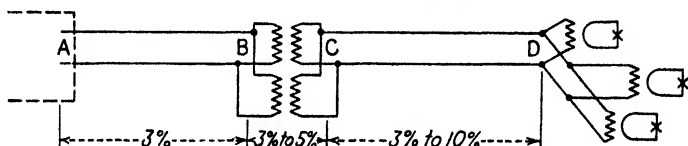

FIG. 13A.—Voltage drop in welder supply circuit.

cables or bus from the welder to the power transformer, (2) larger or special power transformers, (3) new location of transformers closer to the welder, (4) a different supply voltage for the welder, (5) special service from the power company, and (6) a welder using series capacitors,<sup>25-1</sup> to keep within limits of the present power service. These problems cannot be covered here,\* except to show why some of these changes are necessary.

As shown in Fig. 13A, the voltage drop or change caused by a welder is produced in three parts of the circuit. First, there is a voltage drop along the supply line between the power company's substation A and the place where power is purchased, B. Next is the voltage drop through the power transformer, B to C. The last part probably has the largest voltage drop, between the power transformer and the welding machine, C to D. Since the total of all these voltage drops should not be more than 10 per cent for best results, each part must be studied carefully for possible improvement.

\* Refer to "Power Supply for Resistance Welding Machines" prepared by AIEE Committee on Electric Welding, in *Electrical Engineering*, May, 1940, and May, 1941.



**13-4. Power Transformers.**—Except in new plants, power transformers are usually standard units grouped in a three-phase bank. They supply general plant load and pay little attention to welding machines. Each welder is a single-phase load. A number of such welders is usually divided so that some of the welders are connected to each phase. If a 200-kva spot welder is supplied from one phase of a standard 1000-kva, three-phase transformer bank, this welder load can cause 5 to 8 per cent voltage drop through the transformers alone. Voltage conditions are greatly improved by using separate power transformers to supply such welder load. Where separate transformers are used for large welders, they should be located within 50 ft of the welder if possible. This may require transformers using askarel to prevent fire hazard in working areas.

Where a number of large welders is supplied through two or three power transformers, past practice has been to connect a transformer and several welders in each phase. However, there is less voltage drop at each welder if all these transformers are connected in parallel on just one phase and all the welders are connected to this phase, as shown in Fig. 13A.

To supply welders, power transformers must be large enough to carry the load without overheating, and must not permit too much voltage drop. The name-plate rating of a single power transformer should be larger than the name-plate rating of any spot welder that it serves. Many spot welders may operate from one transformer, until the total of these welder ratings becomes five or six times the transformer rating.

The voltage drop in the transformer depends on the measured load and the transformer impedance. (*Impedance* is the amount by which the transformer prevents a.c. from passing through its windings, just as *resistance* tries to prevent d.c. from passing.) A 200-kva transformer, built with 5 per cent impedance, will itself cause nearly 5 per cent voltage drop when carrying 200 kva of welding load, or will cause 10 per cent voltage drop at 400-kva load. Special transformers are sometimes built with low impedance for supplying welders.

To select a power transformer to serve a 150-kva spot welder, it is necessary to know the greatest load drawn by this welder and the greatest voltage drop that the transformer is to be per-

mitted to have when carrying this load. If this welder load is 400 kva and the voltage drop of the power transformer must be only 3 to  $3\frac{1}{2}$  per cent at 400-kva load, there are several transformers which may be used. A standard 333-kva transformer with 4 per cent impedance will have too much voltage drop, but a special 333-kva transformer with  $2\frac{1}{2}$  per cent impedance will be about right. Standard transformers are more quickly obtained, so think about using other sizes. A 500-kva, 4 per cent impedance transformer may be used. A single 200-kva,  $4\frac{1}{2}$  per cent impedance transformer has 9 per cent voltage drop at 400-kva load, but three of these 200-kva transformers can be connected in parallel, to give 3 per cent drop.

**13-5. Selecting Supply Voltage.**—The supply voltage is chosen early in the life of an industrial plant, and so most welders are connected to whatever voltage is already available. The welder itself will work at whatever voltage it is designed to use. However, a 220-volt welder may not be able to get its 220 volts as easily as a 440-volt welder can get its 440 volts. This is no fault of the 220-volt welder, but it is caused by too small 220-volt feeders. Since a 150-kva, 220-volt welder draws twice as much current as a 150-kva, 440-volt welder, the feeder supplying this 220-volt welder must be at least twice as large as a feeder to supply the 440-volt welder. As a result, 220 volts is not so good as 440 volts for supplying larger welders or welders located 100 to 400 ft from the power transformer. There are many plants using 220 volts for motor load which have changed their welder feeders to work at 440 volts. Some plants use 575 volts for welders, and many large welders are now working at 2300 volts. These changes to higher voltages decrease the voltage drop at the welders.

The ignitron tubes work better at 440 volts and may often be used with larger welders than is possible at 220 volts. In general, 440 to 575 volts is better for large welders. As an exception, welders corrected by series capacitors (see Sec. 13-12 and Chap. 25) can use 220-volt feeders to prevent excessive voltages across the tubes and capacitors.

**13-6. Cable Sizes.**—To reduce the voltage drop between the power transformer and the welder, large cables or busses are necessary. (Cables are preferred where the welders are grouped

together, but large busses can be tapped at various points for welders scattered at different distances from the power transformer.)

Most welders draw so much current that they need larger cables than the No. 6, No. 3 or No. 0 sizes commonly used for motor circuits. Larger cables are shown in Table V. It is well known that No. 6 wire is much larger than No. 12 wire. No. 3 has twice as much copper (cross section) as No. 6, and No. 0 has twice as much copper as No. 3. Wires continue getting larger through Sizes 00, 000 and 0000 (called "Size four zero"). There is no numbered wire size larger than 0000, but there are

TABLE V.—SIZES OF CABLES, LOADS AND VOLTAGE DROPS

Wire size	Circular mils	Amperes capacity		Voltage drop,* carrying current of column B	
		Continuous (A)	At 10 per cent duty (B)	Cables 2 in. between centers (C)	Cables 10 in. between centers (D)
6	26,250	70	220	40	42
3	52,640	100	310	33	40
0	105,500	150	480	32	41
0000	211,600	230	730	33	47
	300,000	300	950	37	56
	400,000	350	1100	38	60
	500,000	400	1260	39	64
	750,000	500	1560	41	72
	1,000,000	580	1830	43	80

\* Voltage drop in cable only, measured 300 ft. from the power transformer, when carrying current of column B at 0.4 power factor.

larger cables whose size is given in circular mils,\* as shown in Table V.

Notice that Size 0 cable is the common name for cable that has 105,500 circular mils in cross-sectional area. Larger than 250,000 circular mils, or 250-MCM cable, there are many sizes

\* A mil is  $\frac{1}{1000}$  inch, and a circular mil is the area of a circle  $\frac{1}{1000}$  inch in diameter. Cable of the size of 1,000,000 circular mils has the same cross-sectional area as a complete circle which has a diameter of 1 inch. A 300,000-circular mil cable is also called 300-MCM cable (MCM stands for "thousands of circular mils").

of cable. The more popular sizes are shown in Table V, together with the continuous current load that these cable sizes can usually carry, when properly insulated and installed.

For supplying power to spot welders, cables are often expected to carry much greater current than their continuous capacity in amperes. Cables can carry current more than three times their continuous rating, provided this current flows for only one-tenth of the time. For cables working at this 10 per cent duty,<sup>5-8</sup> the amount of current that each size of cable can carry is shown in column *B* of Table V. Such cable loading is not recommended, but such load conditions are often found where more and larger welders are being added, as long as the cable does not overheat.

Although cables may carry such large momentary loads without becoming too hot, still the voltage drop in such cables may be too great. To show how large this voltage drop becomes, column *C* of Table V shows the number of volts drop measured at a welder\* 300 ft distant from the power transformer, at the moment when the welder draws the amount of current given in column *B*.

For example, if a 300-ft feeder of 500-MCM cable is used to supply a spot welder that requires 1,260 amp. while making a weld, then the voltage at the welder will drop or dip at least 39 volts. This 39-volt drop is about 9 per cent of a 440-volt supply, but is more than 17 per cent if the welder is using a 220-volt supply.

**13-7. Keeping Cables Close Together.**—The voltage drop of column *C* of Table V is produced in cables that are kept so close together that the centers of the two cables are only 2 in. apart. If these same cables are separated until they are 10 in. apart, measured between centers, the same amount of welder current will cause more volts drop, as shown in column *D*. To prevent these larger voltage drops, welder cables should be kept tightly together at all points. Such cables are often bound or tied together because they try to separate when large currents pass through them. To supply very large welders, annular cables are often used (see Table VI) to reduce the voltage drop further. These annular cables have a fiber center, so that each copper strand carries its share of the total current.

More special cables are made with both conductors or lines built into one cable. One of these conductors is inside of and

\* An average spot welder, operating at 0.4 power factor.

surrounded by the other conductor, with insulation separating the two conductors. This is called a *concentric cable*, and is often the only cable that can carry large currents for great distances.

As shown in Table V, the distance between cables is very important in a-c circuits. The same cables can carry large direct currents (d.c.) with only a few volts drop. These large cables resist the flow of this rapidly changing a.c. (60 cycles per second) much more than they resist the flow of d.c. This is because the cables have *reactance*, which tries to prevent any changing current from passing through them. In cables larger than 300 MCM, this reactance is greater than the resistance of the cable and causes most of the voltage drop in the cable. This reactance increases as the cables become separated, and is much less when one cable is inside the other cable.

Some industries still have power feeders draped over the roof tops, where the cables may be 1 or 2 ft apart. Certainly such feeders must be rearranged before they are used to supply welders. All insulated cables should be close together, and should never be separated by magnetic materials as, for example, when two cables are fastened to opposite sides of a steel girder.

**13-8. Recommended Cables for Welders.**—As much as 20 to 40 per cent voltage drop will be measured in cables carrying the loads shown in column *B* of Table V. These large voltage changes may have been used and tolerated in the welding of ordinary steel parts, but they prevent good results in the welding of modern alloys and special metals. Today any voltage drop greater than 5 to 10 per cent can cause difficulty in getting good consistent welds. Many large plants now select or design their welding feeders for only 5 per cent voltage drop, knowing that this is only part of 10 to 15 per cent total drop measured at the welder. To limit the voltage drop to 5 per cent, Table VI shows the sizes of cable necessary for various loads and distances. For example, suppose a 100-kva spot welder is located 150 ft from the power transformer and draws 1000 amp at 220 volts. Notice at the bottom of Table VI that this 150-ft distance at 220 volts must be doubled to 300 ft in order to use the 440-volt table. With cables in contact, select 1000 amp load, at 30 per cent duty. Under the 300-ft distance, the required cable size is shown as 600. This is 600-MCM, or 600,000-circular mil, cable. However, if this same welder is 200 ft from the power transformer, the 400-ft-

distance column is used, and the required cable is 1500(a). This is 1500-MCM, or 1,500,000-circular mil, cable of annular construction. This large annular cable is needed only to reduce voltage drop, for a 600-MCM cable can carry this same load without overheating. These recommended cable sizes may seem very large, but they emphasize the need for locating power transformers close to large welders so that special large cables will not be required.

TABLE VI.—CABLE SIZES FOR USE WITH RESISTANCE-WELDING MACHINES  
(Approximately 5 per cent voltage drop in cable)

Current during weld, amperes	With cables in contact, distance from supply transformer to welder, at 440 volts*			Cables 5 in. apart, distance from supply transformer to welder, at 440 volts*		
	50 to 200 ft	300 ft	400 ft	200 ft	300 ft	400 ft
30 per cent duty (average spot welder)						
100	6	4	3	6	4	2
250	00	00	00	1	0	000
500	0000	0000	300	0000	400	800
750	400	400	600	400	1500	2500(a)
1000	600	600	1500(a)	800	2500(a)	
1500	1250	2250(a)	.....	2500(a)		
2000	2000(a)					
70 per cent duty (scam welder)						
100	2	2	2	4	4	2
250	000	000	000	00	00	000
500	400	400	400	400	400	800
750	800	800	800	700	1500	2500(a)
1000	1500	1500	1500(a)	1250	2500(a)	
1500	2500(a)	2500(a)	.....	2500(a)		

\* If circuit is 220 volts, multiply actual distance by 2 before using above values.

(a) Means annular cable (with fiber center).

**13-9. Bus Connections.**—Instead of using large cables, copper bus is often used to connect transformers and welders. Here again, the busses must lie close together to decrease the voltage drop. Special bus sections are sometimes used, in which the copper busses are separated only by thin insulating strips. Where each line or leg uses several parallel busses, these are

interleaved to reduce voltage drop (by arranging each copper strap so that it is between two straps of the opposite polarity). Concentric bus is also used, built with one copper tube inside of another copper tube, with an insulating tube between them. Such concentric bus, or wide strap busses ( $\frac{1}{4}$  by 12 in.) very close together, provide the best way to carry thousands of amperes for hundreds of feet with small voltage drop.

Cables and busses are discussed in "Power Supply for Resistance Welding Machines"; see footnote to Sec. 13-3.

**13-10. Welding Limited by Available Power.**—The proper selection and use of bus, cable, and transformer reduces the voltage drop and conserves the available power after it reaches the industrial plant. However, unless the plant is located where it is supplied by a large power system that is prepared to handle the sudden load demands of large welders, there are serious limits to the amount of load that can be used for welding. Only the largest power substations can serve a large spot or butt welder unless very costly changes are made. Such changes or the strengthening of feeders supplying a plant cannot be repaid just from the sale of the power used for welding. The use of large welders is often limited by the large cost of these changes. There are several ways to reduce the loads that welders demand from the power system, and some of these methods probably cost less than the changes in the power supply.

One way to supply a welder from a limited power system is to use a motor-generator set. This rotating equipment absorbs the large kva "bump" of single-phase welder loads, but draws a much smaller current that is divided equally among all phases of the power line. The generator of such a set must be large enough to supply the large welder current, and without too much voltage drop at the generator terminals. Such a generator is much larger than the motor that drives it.

Where local power supply is unable to handle the sudden load of a spot welder, portable engine-driven generators are sometimes proposed for this purpose. Here again the generator must be able to handle the peak welder load without too much voltage drop. If accurate tube control is to be used with the welder, a separate constant-voltage a-c supply is also required, produced by a small separate generator on the same shaft with the main generator.

**13-11. Capacitors Used with Welders.**—The load drawn by a welder can be greatly reduced by using a large bank of capacitors (hundreds or thousands of microfarads). The capacitors decrease the welder load by correcting or overcoming much of the welder current. Capacitors\* are connected in two different ways: (1) across the welder transformer in shunt or parallel connection, or (2) in series with the welder transformer, where the capacitor carries the same current that is flowing in the welder.

Shunt capacitors are better known because they are widely used for power-factor improvement in industrial plants. Such capacitors operate at full line voltage. When they are connected to the same feeders as the welders, the capacitors decrease the current in the feeder, and perhaps also increase the voltage at the place where the capacitors are connected. For these reasons some plants try to use these shunt capacitors to decrease the sudden voltage drop caused by the welder operation. However, if the capacitors are connected across the line at all times, the voltage drop during the weld is not decreased. For example, if the voltage at a welder dips from 460 down to 420 volts during a weld, the addition of shunt capacitors may improve the voltage from 420 to 435 volts during the weld, but the 460 volts between welds is also raised to about 475 volts. The amount of voltage change (40 volts) is about the same either with or without this shunt capacitor. Enough capacitors to reduce the welder load appreciably cannot be connected to the feeder without raising the feeder voltage too much.

Shunt capacitors are used successfully with butt welders which draw welding current for several seconds continuously. Here the shunt capacitors are connected directly across the welder transformer so that the capacitors are energized only when the line contactor passes current to the welder transformer. Enough capacitors can be used in this way to reduce the load drawn by the welder and also improve the voltage at the welder. However, this same connection of shunt capacitors is not successful with spot or seam welders, because of the high surge currents that flow each time the circuit to the welder is closed. In general, shunt capacitors are not used where large welder loads must be limited or improved.

\* Capacitors in stored-energy welding are described in Chap. 26.



**13-12. Series Capacitors.**—In recent years series capacitors have been used with many large spot or seam welders, making it possible to connect these welders to power systems that cannot handle the welders alone. Series capacitors are built just like shunt capacitors, but are merely connected into the welder circuit differently. Series capacitors cause no surge currents, but they do require the use of welder controls of special design as described in Chap. 25. To show the decrease in load resulting from a series capacitor, consider a 250-kva spot welder, which by itself requires 800-kva load when making a weld and which may cause 40 per cent voltage drop. If the welder draws this 800-kva load at 0.4 power factor, then the addition of series capacitors decreases this load to about 350 kva in making the same weld. However, the voltage drop becomes much less than  $\frac{350}{800} \times 40$  per cent. Since the 350-kva load is drawn at about 1.0 power factor, the voltage drop may be decreased to as little as 5 per cent.

A separate series capacitor is required with each individual welder, except where several identical welders (used on identical jobs) are interlocked so that only one welder uses the series capacitor at one time. Any series capacitor must be carefully designed to fit the load conditions of the individual welder with which it is to be used.

**13-13. Energy-storage Welding.**—Another way to produce spot welds without drawing too much load from a limited power supply is to use a different design of welding machine which works on the stored-energy principle. In such machines the weld is made suddenly with a large amount of current, but this large current is not drawn directly from the power line. Instead, the welding energy is accumulated gradually and stored electrically by a small current drawn from the power line between welding operations. Various types of such energy-storage welding equipment are discussed in Chap. 26. Because of the small current requirements, these welders do not need such careful choice of power transformers or feeders. However, energy-storage welders are used mainly in the welding of aluminum alloys and may not be so well suited to the welding of steel parts.

## CHAPTER 14

### THE PROBLEM OF GETTING GOOD WELDS

Many welding machines have been working for years, with their welding currents controlled by magnetic contactors, ignitron contactors or Weld-O-Trols. The reason these welders have been satisfactory is that they have been welding mild steel or other metals easy to weld. Most of the machines have been welding thick or heavy pieces of metal that needed the flow of current for  $\frac{1}{8}$  to  $\frac{1}{2}$  sec to produce each weld. Moreover, enough welds were used to join any two pieces so that several of these welds might fail, yet the remaining welds would give the necessary strength. For this kind of welding, contactors will continue to be used.

**14-1. Welding Special Metals.**—While some metals were being welded so easily, other metals could not be welded at all. Not so many years ago the spot welding of brass, stainless steel or aluminum was very uncertain, if not altogether impossible. Reliable methods are now being used for welding these materials. The secret underlying all these methods is very accurate timing and control of the welding current—much more accurate than can be obtained with the best tube contactor and automatic weld timer. As the welding of these certain metals and new alloys became possible, the need appeared for greater accuracy of welding all metals, to eliminate frequent weak welds and to make sure that almost every weld would be good. Welding engineers now fully realize that these better welds are made by the most accurate timing control. Accurate controls are discussed in Part II of this book. To understand how these accurate controls must act so as to give the best welding results, it is first necessary to know what things control the heat that makes a weld and why this heat is especially hard to control in welding stainless steel or aluminum.

**14-2. Weld Heat.**—As previously mentioned,<sup>2-11</sup> the heat needed to weld two pieces of metal together is produced by thousands of amperes of current flowing through the resistance

of these metal pieces. Furthermore, if this current is made twice as large, it does not merely double the weld heat; the heat becomes four times as great. This is the same as saying that the weld heat increases at the same rate as the current  $\times$  current increases, or the heat "increases as the square of the current." When current increases to 1.2 times its former amount, the weld heat increases to  $1.2 \times 1.2 = 1.44$  times its former amount. Also, heat is produced as long as the current continues to flow, so the heat in a 3-cycle weld will be only half as much as the heat in a 6-cycle weld made by the same current.

Since the weld heat increases at the same rate as the resistance ( $R$ ) or the number of cycles of time ( $T$ ) increases, and heat also increases as the current ( $I$ )  $\times$  current ( $I$ ) increases, the formula for the weld heat is:

$$\text{Heat} = \text{resistance} \times \text{time} \times I \text{ (current)} \times I \text{ (current)}$$

or

$$\text{Heat} = I^2RT$$

From this formula it is seen that (1) doubling the time length of current flow also doubles the heat, (2) doubling the resistance between electrodes also doubles the heat, and (3) doubling the amount of amperes of current makes the heat four times as great.

The welding of mild steel is easy because a large number (5 to 20) of cycles of time ( $T$ ) can be used, and this steel has large enough resistance ( $R$ ) so that a weld can be made by quite small welding current ( $I$ ). In contrast, aluminum or brass must be welded in much shorter time (often only 1 or 2 cycles), and the resistance of these metals is so small that the welding current must be made very large. These large currents are hard to obtain unless the power supply is large and carefully arranged.<sup>12-1</sup>

The resistance ( $R$ ) between electrodes depends not only on the materials of which the work pieces are made, but also on the pressure with which the electrodes squeeze these pieces together. To weld aluminum or other low resistance materials, some machines use less electrode pressure, so as to increase the contact resistance  $R$  and make the weld with smaller current  $I$ . However, if any welder is out of adjustment so that its welding current can flow just as soon as the electrodes first touch the work, the resistance  $R$  is so large that an unusually large amount of heat

is produced, and this can damage the electrodes and the work or injure the operator.

**14-3. Accuracy of Short-time Welds.**—Years ago, metals like aluminum could not be readily welded because there was no way to pass large welding currents for a short enough time. The nature or structure of such metals requires that the weld be made very quickly. Current flowing more than a few cycles may ruin the weld. Today we have ignitron tubes that can pass very large currents for 1 or 2 cycles, but these ignitrons must be very accurately controlled if most of these welds are to be good. If an ignitron contactor alone is used to control welds shorter than 3 or 5 cycles, one weld may be good but the next ten welds may be much too hot or too cold. This trouble continues even when the ignitrons are controlled by a device that accurately measures the length of this 3-cycle time. To give good short-time welds, the ignitrons must be started by a control device which is so accurate that the ignitrons can start to pass welder current only at one certain point during any cycle of the a-c power supply.

The a-c wave (first described in Sec. 2-4 and Fig. 2A) is shown again in Fig. 14A, which pictures the changes in line voltage during 1 or 2 cycles of time. When this voltage supplies a welder, the circuit must always be closed at some certain point like X, in order to get a smooth flow of current into the welder. Of course, the circuit can also be closed equally well at Y, which is at the same point of the voltage wave, but in another cycle. However, if the circuit is closed at Z, the weld will be hotter than before. Closing the circuit at W will make the weld still hotter. To get the same heat into each short-time weld, the circuit must be closed within a length of time which Fig. 14A shows is only  $\frac{1}{2000}$  sec. If the weld starts  $\frac{1}{1000}$  sec too soon, the heat in that weld will be increased. Welder controls that work with this fine accuracy are called *synchronous controls* and are described in the following chapters.

**14-4. Current and Voltage Wave.**—The reason why point X or Y is the best place to start the welder current is shown in Fig. 14B. Two a-c waves are shown. One wave is the same voltage wave shown in Fig. 14A. The other is the current wave which shows how the current is changing in the line circuit to the welder. This current wave has the same curved shape as

the voltage wave. (The height above and below the 0-0 line is not important.) However, notice that the current wave crosses the 0-0 line at X, which is to the right of point A where the voltage wave crosses the 0-0 line. In all such curve pictures, time is moving toward the right, so point X is perhaps  $\frac{1}{6}$  cycle or  $\frac{1}{360}$  sec later than point A. This current curve is lagging  $\frac{1}{360}$  sec behind the voltage curve, or it is said that the current

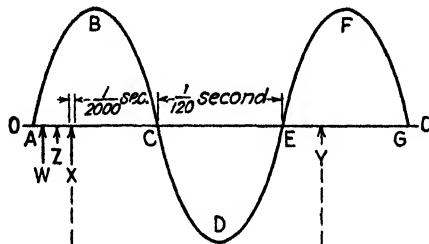

FIG. 14A.

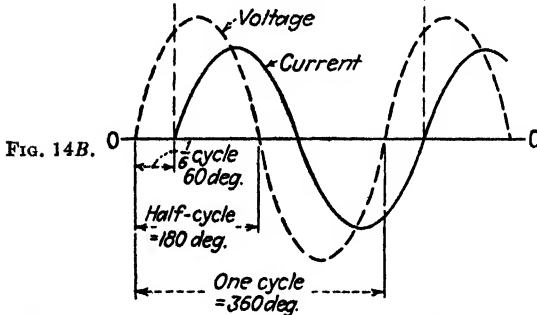

FIG. 14B.

FIG. 14A.—Closing the welder circuit at various points on the voltage wave.  
 FIG. 14B.—Curves of voltage and current in a welder circuit.

lags behind the voltage. The amount by which the current lags behind the voltage depends on the design of the welding machine. A very compact welder whose electrodes are close to the welding transformer will not make the current lag the voltage as much as will a welder with long arms or deep throat.

**14-5. Power Factor.**—Instead of saying that the current curve lags  $\frac{1}{360}$  sec, or  $\frac{1}{6}$  cycle, behind the voltage curve, it is better to say that the current lags 60 degrees behind the voltage as shown in Fig. 14B. A complete circle or a complete cycle contains 360 degrees, so  $\frac{1}{6}$  cycle = 60 degrees, which is the angle by which this welding current is lagging behind the voltage.

This angle is also called the *power-factor angle* of the welder. From the study of trigonometry, it is known that every amount of angle has certain number ratios between the sides of the right triangle of which it is a part, and one of these ratios is called the *cosine* of the angle. This cosine is also the power factor. For example, if welder current lags  $\frac{1}{6}$  cycle, or 60 degrees, behind line voltage, then this welder circuit is working at 0.5, or 50 per cent, power factor, since it is known that the cosine of 60 degrees is 0.5, or 50 per cent. Also, if a spot welder is working at 0.3, or 30 per cent, power factor (measured by using a voltmeter, ammeter and wattmeter), this means that 0.3 is the cosine of the power-factor angle. Using trigonometric tables in a handbook, it is found that 0.3 is the cosine of an angle of about 73 degrees. Therefore, current flowing in this welder lags about 73 degrees (or about  $\frac{1}{5}$  cycle) behind the line voltage.

**14-6. Reactance.**—The name *reactance* is given to that nature or property of a welding machine and transformer which causes the transformer current to lag behind the line voltage, as mentioned above and shown in Fig. 14B. This reactance is not desired or purposely included in the transformer design; it just occurs naturally as the result of winding so many turns of wire around the transformer iron core, or it results from the high-current secondary circuit of the welder, which perhaps is connected to welder arms and electrodes reaching out to make a weld far from the edge of a piece of metal. Even a piece of magnetic material (like steel or iron) between the electrodes and extending into the welder throat contributes to the amount of reactance\* in the whole welder circuit.

\* To be technically correct, the location of the cables, turns of wire and other circuit parts determines only the *inductance* of the circuit. However, when all these parts are operating from a certain power supply, such as 60 cycles, of good wave form, then the inductance has a direct ratio to the inductive reactance, or reactance  $X = 2\pi \times 60 \text{ cycles} \times L$  (inductance in henrys). In the same way, the size and design of capacitors determine their own amount of *capacitance*. However, when these same capacitors are operated in a good 60-cycle circuit, then this capacitance has a direct ratio to the capacitive reactance. In this case,

$$\text{Reactance } X = \frac{1}{2\pi \times 60 \text{ cycles} \times C(\text{capacitance in farads})}$$

When capacitors are used to decrease the large current drawn by a welder or to improve the poor-power-factor conditions caused by too many trans-

As mentioned in Sec. 13-7, large cables have much of this reactance, and the amount of this reactance is not a part of one cable alone, but depends upon the distance between that one cable and some other cable that is carrying the current of the return side of that same circuit.

The reactance is really a "drag" on the system. Reactance resists any attempt to change the amount of current flowing through it. It is difficult for the line voltage to start any flow of current through the circuit reactance, but, when this current once gets started, the reactance does not want to let the current change again or stop flowing. The same energy that was put into the reactance so as to get current to flow is now used by the reactance in its attempt to keep this current flowing.

As an example of this same kind of action, suppose a tractor tries to push a heavy boxcar along a track. Even after the boxcar starts to move, the tractor still cannot increase the motion or speed of the car very quickly, for the car resists this attempt to change its speed. The tractor must continue to push for many seconds before the car is speeded up to 5 miles an hour. When the boxcar is rolling at this speed, it wants to keep right on rolling even after the tractor stops pushing. The large amount of energy that the tractor had to put into the car to get it up to speed is now being used by the car to continue its motion along the track. In this example, the tractor corresponds to line voltage, the speed of the boxcar is the welder current, and the boxcar's inertia, or mass of material, acts like the reactance of the welding circuit. Also, the car reaches its greatest speed (maximum welder current), not at some moment when the tractor pushes with most force (maximum line voltage), but just at the last instant when the tractor stops pushing. Therefore, current (speed) lags the voltage (tractor force) whenever a circuit contains a transformer or other inductive reactance.

Continuing this example, after the boxcar has been pushed to a speed of 5 miles an hour, the car can be stopped only by applying the wheel brakes or by letting it coast to rest (like reactance discharging its energy through a resistance). The car would slow down more quickly if it were possible to get the tractor in

---

formers or induction motors in a plant, this merely means that the capacitive reactance of the added capacitors is being used to buck or neutralize part of the inductive reactance of the transformers and motors.

front of the box car and push back against the moving car. (This backward force is like the reverse voltage,  $C$  to  $D$ , in Fig. 14B, which does make the welder current decrease and finally reverse.)

Of course, the boxcar also stops if it crashes suddenly into a string of other cars. The heavier the boxcar (the greater the reactance) or the faster it goes (the larger the current), the more energy is stored in it, and the more damage it can do when it strikes something else. An airplane crashing into a mountain does not hurt the mountain much, but it does things to the airplane. The airplane stopped by a mountain is damaged much worse than the airplane that strikes the tree tops and flounders to a more gradual stop. The *suddenness* with which energy escapes from a moving object (or from reactance) determines how much effect this energy can produce (see also Sec. 26-6).

The energy in the reactance of ordinary contactor coils can damage the contact tips<sup>7-21</sup> that frequently open this reactive circuit. The energy in the reactance of the welder transformer can produce unusually high voltages when the welder current is finally interrupted by the sudden stopping\* of current in ignitron tubes; this explains why the thyrite<sup>4-4</sup> or discharge resistor is placed across the welder transformer.

In one kind of energy-storage welding (Chap. 26), a special welding transformer is designed with very high reactance so that it can store a large amount of electrical energy and then discharge this energy to make a weld.

**14-7. Transient Currents.**—As previously indicated,<sup>14-4</sup> the best point  $X$  on the voltage wave at which to close the welder circuit is at that place where the welder current would normally cross the 0-0 line. Measurement of a welder circuit with a two-element oscillograph<sup>6-14</sup> shows the voltage curve and the current

\* The large current flowing in an ignitron tube cannot be broken or stopped until the current itself decreases to a point close to zero. However, this current consists of electrons being emitted from many tiny bright spots on the surface of the mercury pool of the ignitron. Perhaps 5 to 10 amp pass through each separate spot. As the current decreases near the end of each cycle, these bright spots disappear quickly, one after the other. There is always one last spot which may disappear or "go out" all at once, suddenly stopping the last 5 to 10 amp of current flow. The sudden stopping of even this relatively small current requires that a resistor be connected across the inductive welder transformer to discharge the energy still stored there.



curve, as in Fig. 14B, after the current has been flowing for 10 cycles, or long enough to let the curves settle down to their steady state. However, during the earlier cycles of the weld the current curves may look quite different from Fig. 14B, unless the welder circuit is closed exactly at the best point *X*. In Fig. 14C the dotted line is the normal wave of welder current, and it also shows the current at the beginning of any weld that is started exactly at the best point *X*. However, if the welder circuit is closed too soon, at point *W*, the current wave takes the shape of the solid curve starting at *W*. Notice that this wave rises nearly twice as high as the normal (dotted) curve. During the second and third cycles, the current wave is not so high as during the first

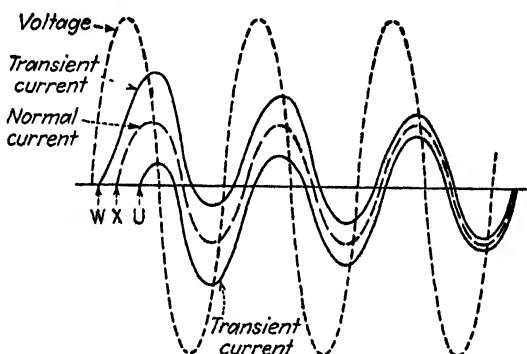

Fig. 14C.—Transient currents (starting before or after the p-f angle).

cycle, which indicates that the current is trying to return to normal. Five or more cycles may pass before this actual current wave becomes the same as the normal dotted current curve. This changed current wave, which lasts for only a short time before returning to normal, is called a *transient current*. A transient occurs also when the current curve starts later than *X*, as shown beginning at *U*. Without accurate synchronous control, some welds may have large transient currents, while welds in between may be more nearly normal. These differences from one weld to the next may be seen with a pointer-stop ammeter, as mentioned in Sec. 6-4.

During these early cycles, the increased welder current also causes increased heat. Since heat increases as current  $\times$  current ( $I^2$ ) increases, a 50 per cent increase in current during the first cycle also causes  $1.5 \times 1.5 = 2.25$  times normal heat during the

first cycle. During the first 2 or 3 cycles, this transient current can cause a total of  $1\frac{1}{2}$  to 2 times as much weld heat as would be produced by the normal current flow. This explains why it is impossible to get good results from welds of 5 cycles or less, unless accurate control is used to make the ignitron tubes close the welder circuit at exactly the same point on the voltage wave for each successive weld. However, the point of circuit closure makes less difference when the weld is 10 or 20 cycles long,\* because any transient affects only the first few cycles out of this larger total number of cycles. Note here that the welding of stainless steel requires such careful control of the heat in each weld that such welds 5 to 10 cycles long, to be consistent, cannot stand the amount of heat change or variation caused by occasional transient currents.

**14-8. Tubes Preventing Transients?**—The question is asked whether the tubes in an Ignitron Contactor or Weld-O-Trol will prevent transients and give better welding results than a magnetic contactor. Such advantages are not claimed, for ignitron tubes certainly can and do produce objectionable transient currents, unless these ignitrons are accurately controlled by added tube-controlled circuits. There is a slight advantage for the ignitron, however, which may or may not be of any importance. The transient current becomes worse as the welder circuit is closed earlier<sup>14-3</sup> or farther ahead of point *X* (in Fig. 14A, farther to the left of *X*). Ignitron tubes can close the welder circuit at *Z* or *W*, but they cannot close the circuit at *A* or just to the left of *A*, because there is not enough line voltage (150 volts needed) to force current through the ignitron at these points on the voltage wave. However, the magnetic contactor can close the welder circuit at any point on the voltage wave, and thereby can cause somewhat worse transient currents.

**14-9. Magnetism Left in Transformer.**—Serious transient currents (see above) and sparking at the electrodes are also caused by the magnetism left in the welding transformer from the preceding weld. In Fig. 14D, if the preceding weld (*A*) ends with a positive (above the 0-0 line) half-cycle of current and the following weld (*B*) also starts with a positive half-cycle, a higher transient current may be produced at the beginning of weld *B*.

\* In even a 20-cycle weld, the transient may cause electrode spitting or a poor weld.

At the end of weld *A*, as current reaches the 0-0 line at *C*, some magnetic flux still remains at *D*, which gradually disappears if given sufficient time. However, if weld *B* starts a few cycles later, with current flowing in the same direction as the last half-cycle of weld *A*, then weld *B* starts with flux *E* instead of normal flux *F*, and the current of weld *B* is higher because of this remaining or residual magnetic flux. However, if weld *A* ends with a negative half-cycle (below the 0-0 line), the residual flux does not affect weld *B*. Most accurate welder controls prevent the possibility of such transients by making sure that every weld starts with a polarity opposite to that which ended the preceding

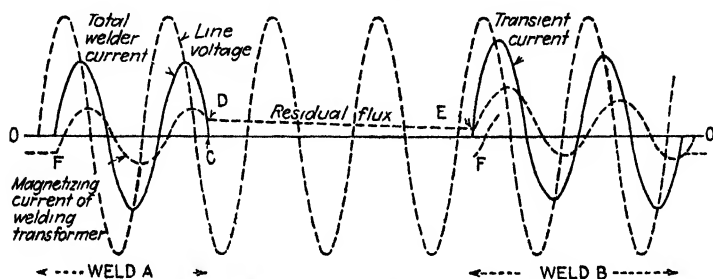

Fig. 14D.—Transient current resulting from residual flux.

weld. This is most important in seam welding, or when spot welds are made with very short time between them.

Sometimes a welder transformer will have so much magnetic energy remaining at the end of a weld that it will affect the operation of tube control as much as 5 to 20 sec later. This situation is often improved by placing a low resistance across the welder transformer primary terminals (like the dummy-load resistor<sup>4-11</sup>).

**14-10. Transients Cause Greater Voltage Drop.**—A transient current, as mentioned above, is greater than the normal current required by the welder. If transient currents are permitted, they cause increased voltage drop at the welder, and also cause greater disturbance in the power-supply system. Often a power system cannot tolerate the greater loads caused by these occasional transient currents, but can stand the normal welder current. Accurate tube control of the welder circuit is often used, mainly to prevent these greater power disturbances.

Transient currents cause increased spitting and heating at the electrode tips. Therefore, increased electrode life can result from the use of control that prevents transient currents.

**14-11. Synchronous Timing.**—To weld special metals with welders working directly from a-c supply lines or to control accurately short-time welds, it is necessary to use tube-operated control panels which accurately start and time the flow of welding current. Such accurate a-c control equipments are called *synchronous timers*. To be correctly called a synchronous timer, such a control must be able to start each and every weld at the same point on the voltage wave, and should also start each weld with a polarity opposite to that which ended the preceding weld. Synchronous timers usually (but not necessarily) include accurate control of the time length of each weld, which can be adjusted in cycles of length or duration. Some synchronous timers include these and other features, together with the ignitron power tubes, all in the same enclosure. However, where an ignitron contactor is already installed and operating with a welder, the advantages of synchronous timing can be obtained by adding accessory control panels that will accurately fire the present ignitron contactor.

**14-12. Summary.**—Previous chapters cover nonsynchronous control—the ignitron contactor, automatic weld timers and circuit fundamentals. The synchronous controls of Part II give the greater accuracy needed to weld aluminum, brass, stainless steel and other alloys, which often permit only a few cycles of current flow. Higher speed welding of steel also improves with accurate control. Since weld heat =  $I^2RT$ , the decrease of weld time and resistance must be offset by an increase in welding current. The amount of heat in such 1- to 5-cycle welds is changed 25 to 75 per cent by the transient currents resulting from non-synchronous control. These transients are caused by closing the welding circuit ahead of the power-factor angle of the welding transformer or by starting a weld with the same voltage polarity with which the previous weld ended. Welders with deeper throats or containing magnetic work have higher reactance and lower power factor, and can cause worse transients. Transients not only produce inconsistent welds, but their presence causes higher momentary load demands from the power system and increases electrode maintenance. Synchronous controls decrease transients by always starting the weld at the same point on the voltage curve. Synchronous controls may be complete with ignitrons or may be accessory panels for addition to existing ignitron contactors.

## PART II

# SYNCHRONOUS CONTROL OF A-C WELDING

### CHAPTER 15

#### SYNCHRONOUS TIMING

The timing or control of welding current by any device that remains accurately in step with the a-c voltage wave is called *synchronous timing*.\* The synchronous timing given by accurate modern welder controls is largely responsible for the successful welding of most metals with a-c power supply. There have been many attempts to produce synchronous timing by motor-driven current switches and special contactors, but real success comes only when electronic tubes are used to carry the welding-machine current, permitting the control of this current with great accuracy. The modern welder control includes so many tube circuits and there are so many kinds of tube control for synchronous timing that many chapters will be used to show the detailed working of these synchronous welder controls.

**15-1. Synchronous Welder Controls.**—Synchronous welder controls include only those electrical equipments operating from a-c power supply which control the flow of welder current through electronic tubes with great accuracy. As summarized in Sec. 14-12, the most important thing done by synchronous control is the prevention of transient currents, so as to produce consistent and short-time welds. To be correctly called a *synchronous welder control* and to give synchronous timing, the control must always start the flow of welder current accurately at the right point on the voltage wave. The welder current should be started with polarity opposite to that with which the previous

\* Most electric clocks have synchronous operation, for their motors turn exactly in step with the rapid changes of a-c voltage. A synchronous motor operates at constant speed because its rotor keeps in step with the constant frequency (rate of a-c voltage change) of the power-supply system.

weld ended. In addition, most synchronous controls include accurately adjustable time control of the duration or length of flow of welder current.

Control panels have been built for many years to provide synchronous timing of seam welders, and more recently for spot and pulsation welders. Additional features have been added, such as phase-shift heat control. The first standard control to be discussed provides synchronous timing of a spot welder. This panel controls only the flow of current to the welder. A sequence control<sup>20-12</sup> is still needed to operate the welder electrodes.

**15-2. Synchronous Spot-weld Timer.**—The front of a synchronous spot-weld timer is shown in Fig. 15A. Figure 15B shows the front door open, looking at the front of the panel. Figure 15C is the rear view with the back cover removed. In this rear view, the two ignitron tubes are seen, supported by their heavy copper busses. These ignitrons are perhaps the only parts of this whole equipment that will be remembered from earlier chapters.

This equipment is a complete spot-welder control, including ignitron tubes in the same enclosure.\* Figure 15B shows that there are four more tubes—one GE-83 rectifier, one FG-17 thyatron and two FG-95 thyatrons. To make sure that these tubes are heated 5 min before going into service, there is a time-delay relay *TR1*. Below *TR1* is a covered telephone relay *CR1*, which starts each spot weld. Beside *CR1* are the 6-amp control fuses, which carry all the current of the panel except the welder current. Below these are two 3-amp fuses, which protect the two lower thyatron tubes. Below *CR1* is a protective contactor *CR2*, which prevents current from passing through the ignitrons unless all operating conditions are normal. At the bottom of the panel, the two large copper terminals are for attaching line cables. The terminal on the right connects to one side of the power line, and the other terminal connects to the welding-

\* This enclosure mounts Size A, B or C ignitrons.<sup>1-2</sup> When Size D tubes are needed, they are mounted in a separate ignitron contactor or in the larger synchronous control of Sec. 20-1.

Where ignitrons are already installed in a tube contactor or Weld-O-Trol, a smaller synchronous control is used (see CR7503-A109 control in Sec. 20-5), which holds only the smaller tubes for control of the existing ignitrons. Its circuits and devices are the same as used in the complete equipment described here, except for its different internal control voltage (460 volts).

machine transformer. Only one main line comes to these terminals. The other line connects directly to the welder (with a connection to panel terminal 2).

On the front door of the control (Fig. 15A) the adjusting knob and selector switch permit changing the length of the weld from

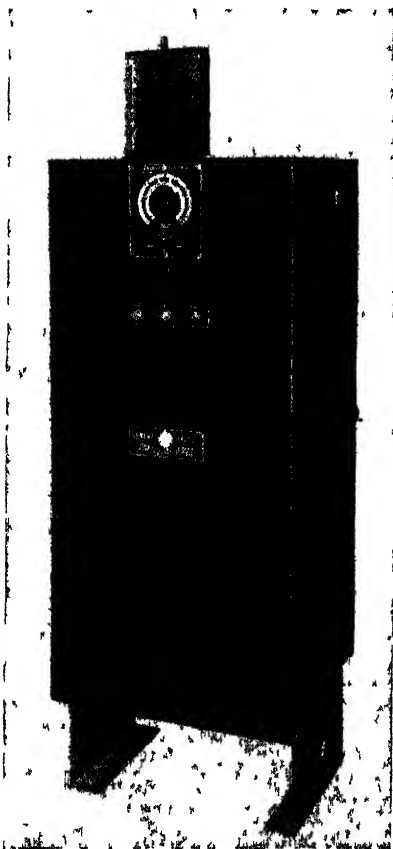

FIG. 15A.—Synchronous spot-welding control.

1 cycle to 2 or 3 cycles, or up to 30 cycles. The three indicating lamps show (red) control power is on the panel, (amber) the proper cooling water is flowing, and (green) the 5-min warming period is finished. The rear view (Fig. 15C) shows large numbers of resistors, transformers, capacitors and terminals. Although

these appear confusing at first sight, they will be studied in orderly groups.

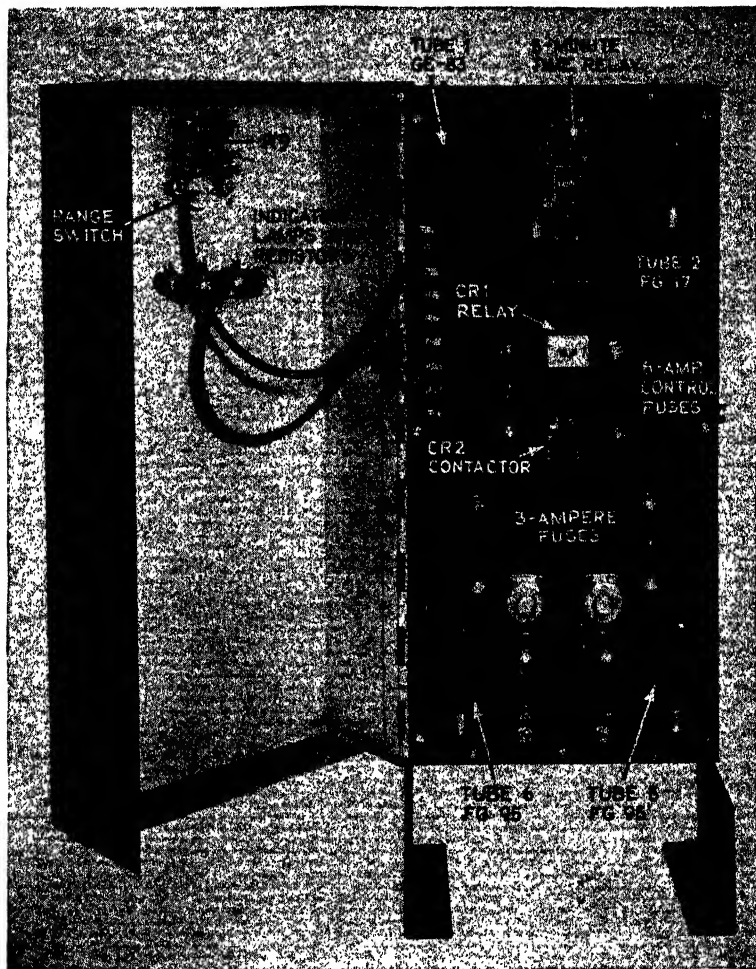

Fig. 15B.—Synchronous spot-welding control (front door open).

**15-3. Connection Diagram (CR7503-A124\* Spot-welder Control).**—The complete diagram of Fig. 15D shows all the parts of

\* The circuit of this control is much like the circuits of other G-E spot-welder controls. See Secs. 18-6 and 18-10.



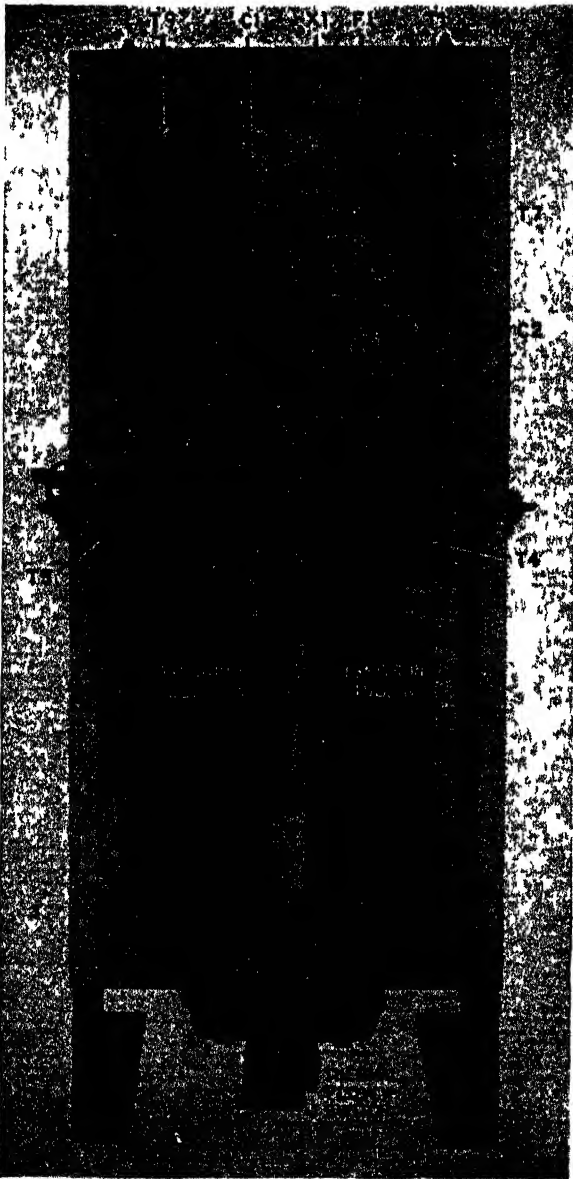
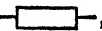







FIG 15C —Synchronous spot-welding control (rear view, open).

the equipment mounted in their proper places (back view of panel) and is used for tracing circuits.<sup>7-8</sup> The six tubes are quickly spotted by their circle symbols (ignitrons, see Fig. 3C; thyratrons, see Figs. 8B and 8C). Also resistors , capacitors , fuses , contactor coils , normally-open contacts , and normally-closed contacts  have been discussed.

The welding transformer is shown in the main circuit, below the dotted line that surrounds the main panel. The work or the weld itself is just the ink spot  $\ast$ , which is far too small to indicate that it is the reason for all this equipment.

Each control transformer on the back of the panel is shown as a dotted rectangle which encloses all its windings. It is quickly seen that transformer *T1* has four separate windings. *T5* has four windings, while *T4* and *T9* have only two apiece. *X1* looks like a transformer with one winding, but it is used as a reactor. Shown on the door to the right is *T7*, which also has just one winding. However, this winding has many taps, so *T7* is an autotransformer. Any available line voltage may be connected to its proper taps, and *T7* will then furnish the 230-volt control voltage (between panel terminals 6 and 7) for operating the panel.

Some of these control transformers have two sets of numbers shown near their terminals. The numbers like (8) or (*H2*), shown closer to the winding, are found on metal tags on the transformer wire leads themselves. The other numbers like 94 or 23 are merely circuit numbers, which also appear at the other ends of the connecting wires on the panel. Sometimes, like *T4*, the transformer leads have different colors instead of numbers.

Terminals at the sides of the panel are connected to devices mounted on the door, using flexible cable with colored wires. Terminals 47 to 49 are used in connecting to certain sequence controls (see Sec. 20-12). The terminal board shown below tube 2 is used only to plug in the connections to an additional heat-control panel<sup>20-4</sup> when used. When not using such an extra panel, six jumpers are added to the terminal board as shown and are disregarded in further study here.

On this panel, the tubes are numbered 1, 2, 5, 6, 7 and 8. Numbers 3 and 4 are reserved for other tubes which are used only on more complete panels, as in Chap. 20. Similarly, trans-

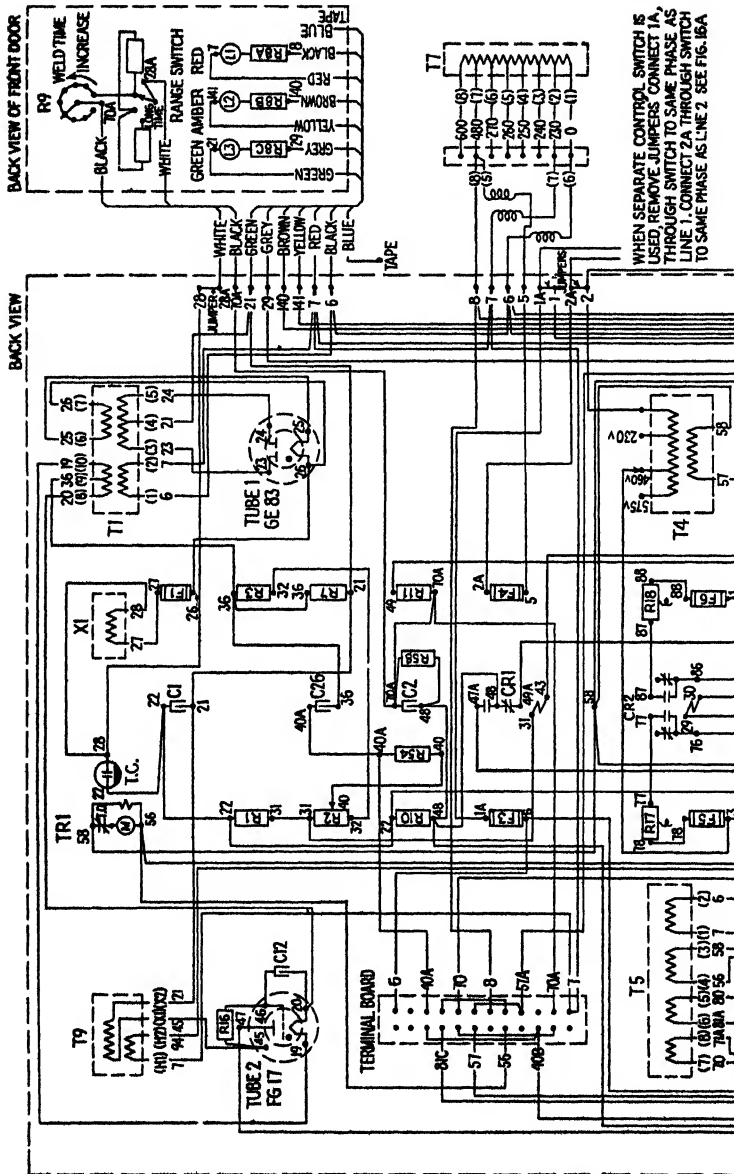

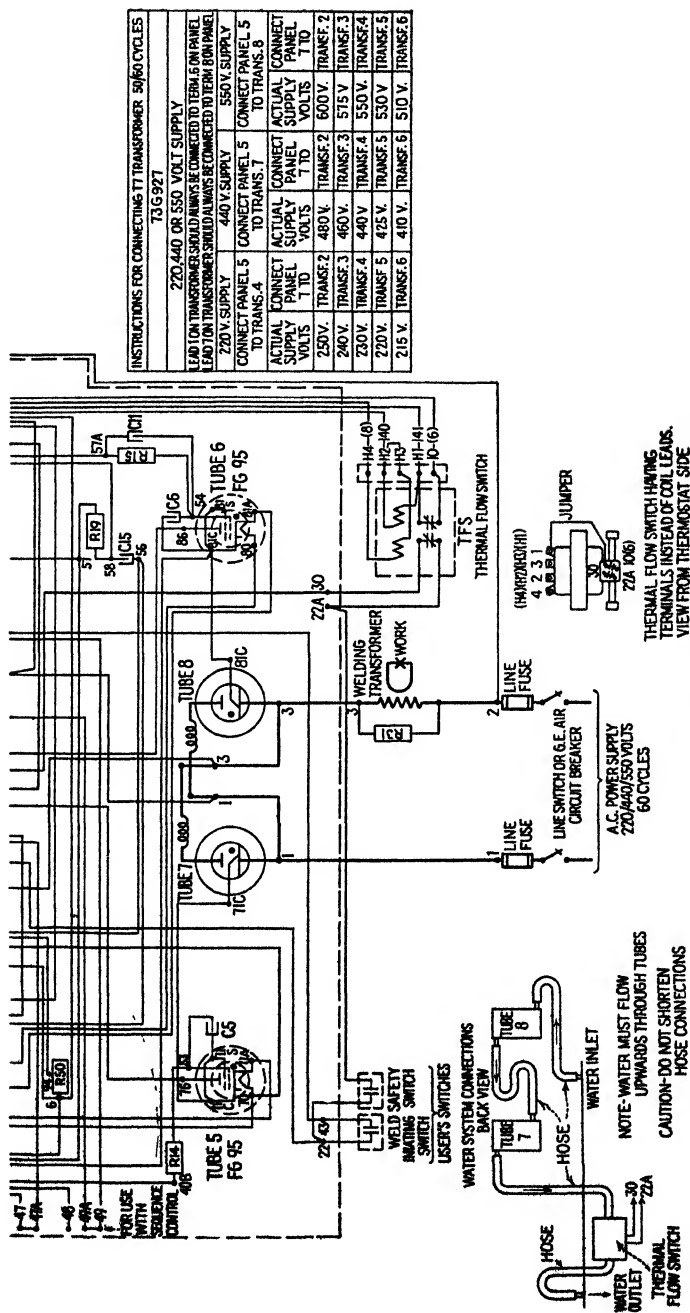

Fig. 15D.—Connection diagram of CR7503-A124 spot-welding control.

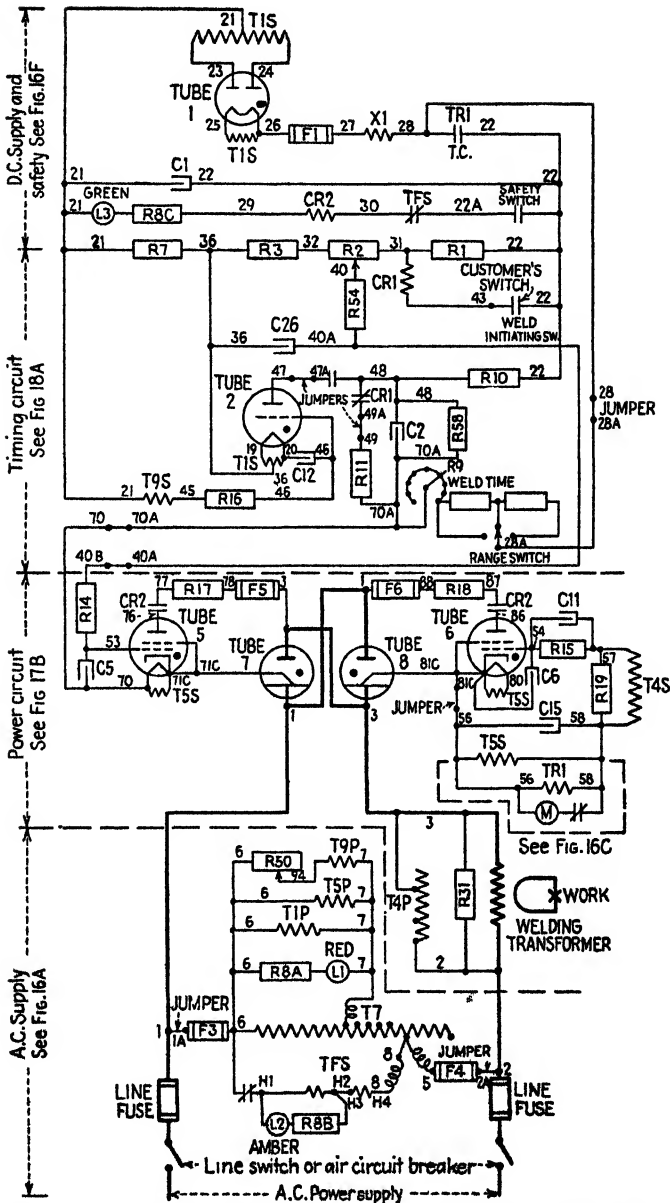

FIG. 15E.—Elementary diagram of CR7503-A124 spot-welding control.

formers are numbered *T1*, *T4*, *T5*, *T7* and *T9*. The missing numbers are used for certain purposes on other panels.

**15-4. Elementary Diagram (CR7503-A124).**—In order to find out how any electrical equipment or circuit operates, the elementary diagram is more easily followed than the connection diagram.<sup>7-4</sup> The complete elementary diagram is shown in Fig. 15*E*. However, there are so many circuits in this one diagram that it will be better to divide it into a number of smaller elementary diagrams. Figure 15*E* shows that this complete circuit divides naturally into the a-c supply circuit, the d-c supply and safety circuit, the power circuit and the timing circuit. Some of these divided circuits appear again in other complete welder controls. Later, in describing more advanced synchronous control equipment, reference will be made to these basic circuits which are described here as part of this first panel.

In contrast to the connection diagram previously discussed, Fig. 15*E* does not try to show all the parts of each device close together. For example, all transformer primary windings are grouped in the lower part of this diagram. *T1P* means "Transformer 1, Primary." A secondary winding of this same transformer appears at the top, where *T1S* furnishes anode voltage to tube 1. Other *T1S* windings (Transformer 1, Secondary) supply filament or heater voltages for tube 1 and tube 2. The power that enters this transformer through its *T1P* winding reappears at each of these three *T1S* windings. Similarly, *T4P* is energized by the voltage across the welder transformer, while its other winding is *T4S*, at the extreme right of the diagram. In the same way, the coil of contactor *CR2* is shown below tube 1, but the two contacts of *CR2* are shown just above tubes 5 and 6.

**15-5. Values of Resistors, Capacitors and Transformer Voltages.**—To understand many of the operations of these circuits, it is necessary to know the number of ohms in various resistors, the mu f size<sup>7-12</sup> of capacitors and the a-c voltages furnished by transformer secondary windings. These values are usually shown in tables on the connection diagram supplied by the maker of the equipment. For easier following, these values are inserted on the partial diagrams in chapters following. This information will then be used to show how other useful values can be quickly calculated.

## CHAPTER 16

### A.C. FOR CONTROL; D.C. FOR TIMING

Synchronous welding-control equipment operates from regular industrial a-c supply lines. However, some parts of the control circuits need different amounts of a-c voltage, and some parts need d-c voltages. Therefore, the part of the complete diagram (Fig. 15*E*) to be studied first should include those circuits which change the a-c line voltage into more useful a-c voltages and which produce a supply of direct current (d.c.) for accurate timing purposes.

**16-1. A-c Control Power.**—As shown on Fig. 15*E*, the lower portion of the elementary diagram furnishes the a-c supply and control power. This portion alone is shown in Fig. 16*A*. Starting with the two cables of the a-c power supply, the main circuit to the ignitron tubes and the welding transformer passes through line fuses and a line switch or air circuit breaker. Control power for the whole equipment passes through the 6-amp control fuses *F3* and *F4*. In Fig. 15*E* jumpers connect these control fuses to the load side of the main line fuses, so that the control panel, as well as the welder, is disconnected by the main line switch. However, most plants prefer to keep the control and tubes “hot” when the line switch is opened for short times. To do this, the connections to fuses *F3* and *F4* are made as shown in Fig. 16*A*, by removing the jumpers and then connecting terminals 1*A* and 2*A* through a 30-amp switch\* to the “hot” or line side of the main line switch. The circuit through the switch, from 1*A*, must definitely connect to line 1, or to a different circuit wire that has the same phase as line 1. If these wires from 1*A* and 2*A* become reversed, or are connected to a different phase, the tubes will not work correctly.

Line voltage, passing through control fuses *F3* and *F4*, is connected to autotransformer *T7*. Wire 6 from fuse 3 always con-

\* The control voltage supply of welder panels should not be connected through this separate switch unless the firing thyratrons (such as tubes 5 and 6) are kept from accidental firing by a protective contactor (like *CR2*).

nects to one end (terminal 1) of the  $T7$  winding, but the place where flexible wire 5 connects to the autotransformer depends on the line voltage, as shown by the instruction table under  $T7$ . Panel wire 7 is to be moved to any one of five taps of  $T7$ , so that the voltage measured between 6 and 7, on the panel, will always be very close to 230 volts. Whether the line voltage is 480 volts, 215 volts or 550 volts, the proper connections to  $T7$  will still give 230 volts between 6 and 7 on the panel. These connections are very important, for a panel voltage much above 230 volts will overheat the thyatron tubes and shorten their life, while a panel voltage much below 230 volts also damages these tubes and causes erratic operation.

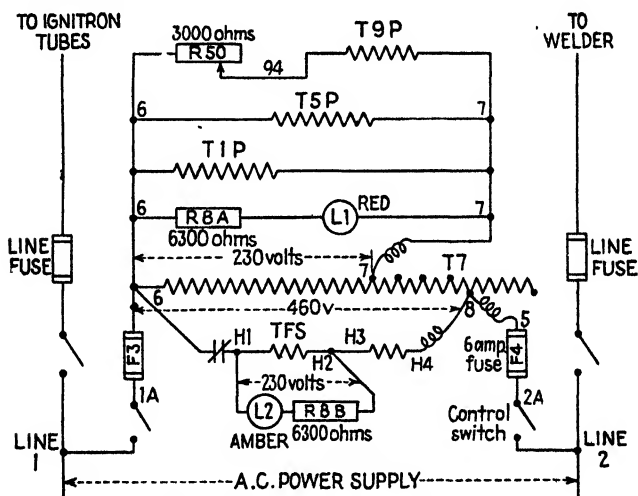

FIG. 16A.—Alternating-current supply circuit.

**16-2. Supply for Control Transformers.**—As shown in Fig. 16A, the 230 volts a.c. between 6 and 7 is used to energize the primary windings of transformers  $T1$ ,  $T5$  and  $T9$ . Most of the control power on the panel passes through these transformers.  $T1$  furnishes the voltage for the heaters of tubes 1 and 2, while  $T5$  supplies tubes 5 and 6. Therefore, just as soon as the 30-amp control switch is closed, these four tubes start to heat. After 30 sec their filaments become red hot. Closing the control switch also lights the red light  $L1$  on the panel door, showing that control power is connected to the panel.



Transformer *T9* furnishes a special voltage from its secondary winding, which starts each weld at exactly the right point on the voltage wave.<sup>15-1</sup> Therefore, notice that *T9P* is connected in series with resistor *R50*. The arrow under *R50* indicates a sliding contact which can change the portion of *R50* that remains in circuit. Moving this slider changes the point at which the weld starts. If the slider is moved to the right on *R50* toward point 94, most of the 3000 ohms is kept in circuit, which makes the weld start earlier on the voltage wave. However, this may start the current flow too soon for a welder of lower power factor,<sup>14-5</sup> so it becomes necessary to move *R50* slider more toward terminal 6. This decreases the portion of the 3000 ohms left in circuit with *T9P*, which makes *T9S* delay the point at which the weld starts. This will be explained further in Sec. 18-2. This adjustment is made when the equipment first starts in service.

**16-3. Water-flow Switch TFS.**—Just below *T7* in Fig. 16A is the circuit of the thermal flow switch which protects the ignitron tubes against insufficient cooling water.

This kind of flow switch (described in Sec. 3-12) has two voltage coils *H1-to-H2* and *H3-to-H4*, which can be connected in parallel for use at 220 volts. However, to make it unnecessary to change these flow-switch connections on this panel, the two coils are left connected in series, as shown in Fig. 16A. They are supplied from points 6 and 8 of *T7*, where 460 volts is always present when *T7* is properly connected. The normally-closed contact between *H1* and 6 is opened when the flow switch has too little water. The opening of this contact lets the thermostat cool down and protects the coils of *TFS*. The amber light *L2* is connected across just one of the flow-switch coils, and is lighted only when the flow-switch contact is closed. The main flow-switch contact (*TFS*), which prevents the ignitrons from firing when improperly cooled, is shown in Fig. 16F.

Each of the three indicating lamps is connected in series with a 6300-ohm resistor (such as *R8B* with amber lamp *L2*). Each lamp is a 24-volt, "telephone" lamp, which draws enough current through the 6300-ohm resistor so that there is about 205 volts drop across *R8B* when there is 230-volt potential between *H1* and *H2*.

**16-4. The 5-minute Time Relay.**—This relay is usually located on the front of the tube panel and is shown in Fig. 16B.

It consists of a small Telechron (synchronous-clock) motor which runs for 5 min before it operates a pair of contacts. In complete diagram Fig. 15E, this relay *TR1* is shown just above the welding transformer and is connected across the transformer winding *T5S*. These parts are shown again in *a* of Fig. 16C, where the secondary winding of transformer *T5* is furnishing the 115 volts a.c. that energizes the solenoid coil of *TR1* and also runs the small motor *M*. This motor has a small high-speed rotor and a set

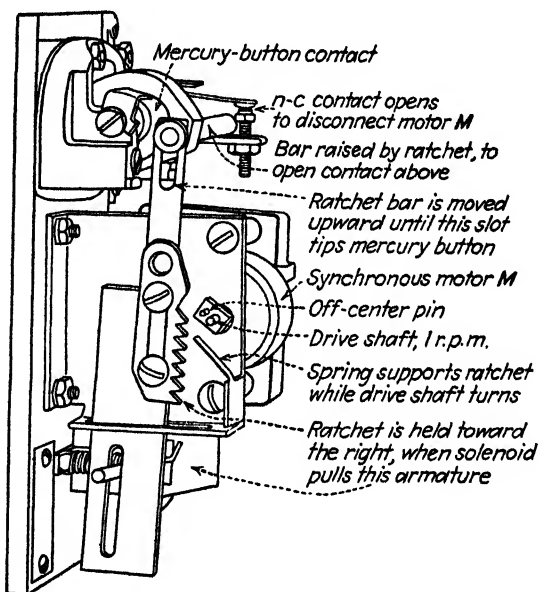

FIG. 16B.—Five-minute time relay.

of gears all enclosed in a can less than 2 in. across. Part of this can is held between the laminated pole pieces (made of thin sheets of metal held together), which carry the magnetism that makes the little rotor turn inside the can. The drive shaft projecting from the can turns once each minute, and this makes an off-center pin lift a ratchet bar one notch each time the pin moves upward. In 5 min this pin raises the ratchet bar five times. On the fifth upward movement, the ratchet bar closes the *TR1* contact, which permits the equipment to start welding service (shown between 28 and 22 in upper right portion of

Fig. 15E or Fig. 16F; marked T.C.—time-closing). After closing this *TR1* contact, the pin lifts the ratchet bar still higher until it opens another contact (normally-closed and visible) which stops the motor. The time relay remains in this position while the equipment is in service. When the control switch is opened to shut down the panel, this removes voltage from transformer *T5* and from the coil of *TR1* relay. This releases the metal arm that the *TR1* coil had been holding in place, and this, in turn, draws the ratchet away from the pin, resetting the time relay for another operation.

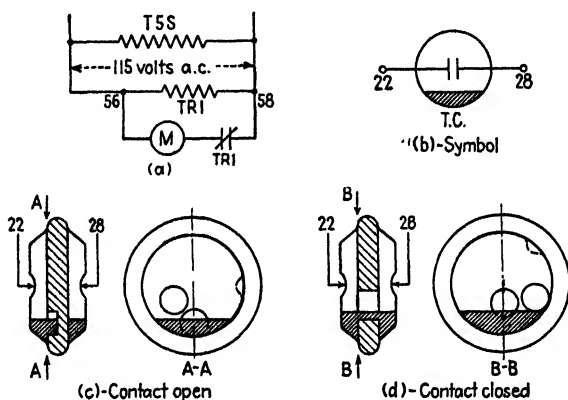

FIG. 16C.—Circuit and button contact of time relay.

If some surge or circuit disturbance removes control voltage from the panel for part of a second, the *TR1* relay resets, and the equipment cannot be used until the relay again times out its 5-min period. (The green indicating lamp *L3* is out during this period.) To eliminate this 5-min wait every time the control voltage is removed and restored is one reason why the control switch is connected ahead of the line switch, as shown in Fig. 16A.

**16-5. Mercury-button Contact.**—The contact of *TR1* that closes the circuit between 28 and 22 is an enclosed contact, inside a special "button" of metal and insulation, whose construction is shown in *c* of Fig. 16C. The symbol for this button contact is also shown\* at *b*.

\* This type of contact is also used in "Sphinx" or silent light switches for home use.

This button is made of two metal half-shells, separated by a center disk of insulating material. Held on edge as shown in Fig. 16C, this button has pools of liquid mercury lying at the bottom, part of the mercury lying in contact with each metal half-shell. The movement of the time-relay ratchet bar turns this button about its center. The contact is normally open (*c*), because the mercury lying on one side of the center cannot touch the mercury on the other side. However, when the button is turned (counterclockwise) to the position shown in *d*, the two pools of mercury join or make contact through a hole in the center disk, and this completes or closes the electrical circuit from 22, into one metal half-shell, through the mercury to the other metal half-shell, and to 28. The electric contacts 22 and 28 may also be the supports in which the button turns. The circuit is opened by turning the button clockwise. This raises the hole above the level of the mercury, which separates into two pools. In the atmosphere of hydrogen and mercury vapor inside the button, the electric circuit is opened quickly and quietly. A second hole, just halfway through the center disk, receives the mercury and helps it open the electric circuit more quickly.

**16-6. The D-c Supply.**—To obtain accurate timing of synchronous controls, a small supply of d.c. is needed. This direct current is obtained by changing or rectifying some of the a-c supply, which is done in the circuit at the top of Fig. 15E. The transformer winding *T1S* has an a-c voltage of 900 volts between its leads 23 and 24, and this a.c. is changed into d.c. by passing through tube 1. About 320 volts d.c. is produced between 22 and 21, which are at the right and left sides of Fig. 15E. This change from a.c. to d.c. is produced in tube 1 with the help of reactor  $\dot{X}1$  and capacitor *C1*. These processes are called *rectification* and *filtering*, and are explained below.

**16-7. Rectification.**—Transformer winding *T1S* and tube 1 are shown again in Fig. 16D. Tube 1 is called a *full-wave rectifier* because this tube straightens out the a.c. into d.c. by passing current during both halves of the a-c voltage wave. Tube 1 has two separate anodes and a double cathode, and works just like two single-anode tubes connected together. The cathode is also the filament, which is heated by a 5-volt winding *T1S*. The dot inside the circle shows tube 1 is a gaseous tube, so it can be expected to show a blue glow when it is passing anode current.

In parts *a* and *b* of Fig. 16D, the circuit from the filament of tube 1 connects to a "load" which represents all the d-c circuits supplied by tube 1 on the welder panel.

The two ends of the winding of *T1S* are connected to the two anodes of tube 1. This *T1S* winding also has a midtap 21, which

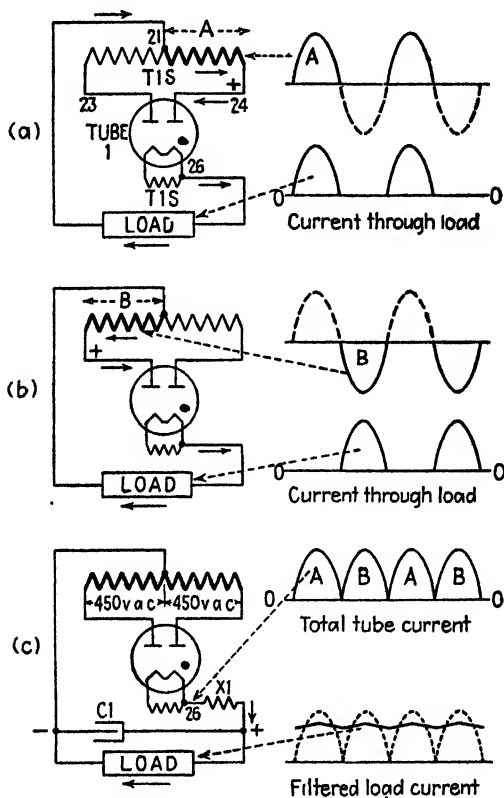

FIG. 16D.—Tube rectifier and filter circuit.

is connected to the negative side of the d.c. produced. While 900 volts a.c. appears between the two ends 23 and 24, the voltage from each end to the midtap 21 is only 450 volts. As the a-c voltage changes (60 cycles per second), first the 24 end is (+) and 23 is (-), then 24 becomes (-) and 23 becomes (+). In *a* of Fig. 16D, point 24 is (+) and forces current through tube 1 from anode 24 to cathode 26, through the load and back to mid-

tap 21. Notice that only the voltage of the *A* half of the transformer winding is used, and this current flows from left to right through the transformer. The a-c curve shows the half-cycle of current flowing through *A*, and just below is the half-cycle flowing through the load. At this same moment point 23 is more negative than cathode 26, so no current flows through anode 23 or the *B* half of *T1S*. Also notice that current flows through the load from right to left.

During the next half-cycle ( $\frac{1}{2}$  120 sec later), shown in *b*, the 23 end of *T1S* is now (+) and forces current through tube 1 from anode 23 to cathode 26, through the load and back to midtap 21. Only the *B* half of *T1S* is making current flow. The a-c curve now shows that the current through *B* is negative or below the 0-0 line, because it flows from right to left through the transformer. No current now flows through the *A* half. However, the current flows from tube 1 and through the load in the same direction as before. Therefore, this half-wave of current is also above the 0-0 line, as before. Therefore, although the current in *T1S* changes direction (above and below the 0-0 line), the current through the load is always in one direction (always above the 0-0 line). This is the rectifying action of tube 1.

**16-8. Filtering.**—As shown in *c* of Fig. 16*D*, the current flowing at tube cathode 26 consists of half-cycles, all above the 0-0 line. This current is no longer a.c., but neither is it d.c. It is just pulsating current, which can be used for some d-c purposes but it is not suitable for most tube or timing circuits. To finish the job of making a usable d-c supply, this pulsating current must be filtered to take out the objectionable ripple or curve that remains of the a-c wave shape. Just as a country gravel road is worn into a rough “washboard” surface which makes an automobile vibrate, so the ripples in this unidirectional (flowing in one direction) current can shake or bother a tube circuit. Also, just as the rough road is made smooth by scraping the ridge tops down into the grooves or hollows, so this pulsating current is made smooth by using electrical devices that take energy from the high spots and discharge this energy into the low spots of the current wave. As shown in *c* of Fig. 16*D*, this smoothing or filtering of the current is done by making the tube current pass through a reactor before it reaches the load, and by connecting a capacitor across the load. This reactor, *X1* is

made of wire wound on an iron core, so that  $X1$  has a large amount of reactance. As described in Sec. 14-6, this reactance tries to maintain a steady current through its winding, by storing energy during moments when current increases and then discharging this energy to help a decreasing current. So  $X1$  helps smooth the current by reducing the high spots and filling the low spots of the curve. Similarly, capacitor  $C17-12$  helps smooth the voltage across the load by charging or storing energy during any remaining points of high current flow and then discharging this energy into the load when current flow has decreased. Just as a road is made smoother by a heavier scraper with powerful drive, so the smoothness of the d-c voltage depends on the size

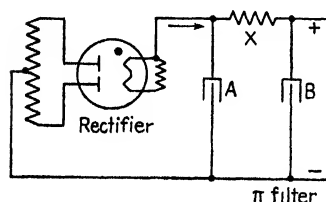

of the reactor and capacitor.  $C1$  is 8 mu f, the largest capacitor used on this welder-control equipment. This capacitor and reactor are the filter circuit, which changes the pulsating current into fairly smooth d.c. at the load. Since current flows through the load only from right to left, the right side is (+) and the left side is (-).

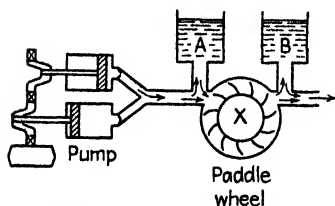

FIG. 16E.—Rectifier compared with a pump.

**16-9. Filter Circuit, Like a Pump.**—Some tube circuits<sup>24-2</sup> require a better d-c supply (free of ripples) than the single capacitor-reactor filter mentioned above can provide. Figure 16E shows a rectifier tube, whose current output is filtered by two large capacitors, with a reactor between them. This combination is called a

*pi filter* because this arrangement resembles the Greek letter pi ( $\pi$ ).

The operation of a full-wave rectifier with its filter circuit is quite like that of an ordinary two-cylinder water pump, equipped with surge tanks and a heavy paddle wheel, as shown in Fig. 16E. In each cylinder, the piston forces water into the pipe during its forward stroke. Just at the time when the pistons change direction, there is no force. The result is a pulsating water pressure, which is smoothed by the surge tanks and paddle wheel. While one piston is in the middle of its forward stroke,

its force starts the heavy paddle wheel turning and also pumps water into tank *A*. At the end of the stroke, before the other piston starts to push, there is no force from the pump. However, the paddle wheel still tries to turn at the same speed and pass the same amount of water between its vanes. This water is supplied from tank *A*, lowering the water level there until the pump can again force water into the pipe and restore the water level in *A*. It is natural for the heavy paddle wheel to try to turn at constant speed and pass steady water flow, just as it is natural for the reactance *X* to try to pass steady flow of current. The water leaving the paddle wheel may still have small pressure changes, and these are further removed by the smoothing action of tank *B*, which receives water during any instant of higher pressure and discharges this water into the line at any instant of lower pressure. With this combination of smoothing devices, the flow of water becomes quite steady. Similarly, the filtered electric current becomes as steady as the d.c. from a battery or d-c generator.

**16-10. D-c Supply and Safety Circuit.**—This combination of a full-wave rectifier tube with filtering reactor *X1* and capacitor

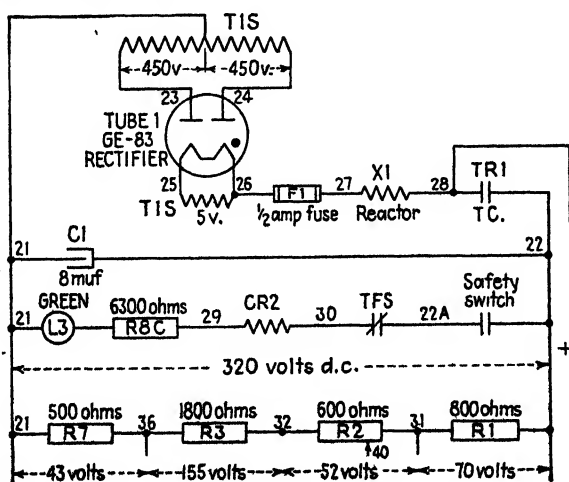

FIG. 16F.—Direct-current supply and safety circuit.

*C1* is shown in Fig. 16F and produces about 320 volts d.c. between points 22 and 21. Some of this d-c supply is used to operate a safety circuit by energizing the coil of contactor *CR2*. If the



safety switch on the welder is closed by the operator, and if enough cooling water is keeping the thermal-flow-switch (*TFS*) contacts closed, then the circuit is complete from 22, through these contacts and *CR2* coil, through the green light and its resistor,<sup>16-3</sup> to point 21. Contactor *CR2* closes its contacts, which permit tubes 5 and 6 to fire the ignitrons, to pass line current to the welder. However, notice that *CR2* is not energized and cannot pick up until contact *TR1* is closed by the 5-min time relay. In this way *TR1* prevents all tubes from passing anode current, until the 5-min warming time is completed. (Tube 1 passes very small current through connection at 28, but the blue glow in tube 1 becomes much brighter when *TR1* contact closes.)

The green indicating lamp *L3* does not light until the end of the 5-min warming period. Even then it does not light unless there is proper water flow and the operator has closed the safety switch. If lamp *L3* is burned out or makes poor socket contact, the passage of welder current is prevented.

**16-11. Voltage Divider.**—The rectifier and filter circuit of Fig. 16*F* gives a supply of 320 volts d.c., but it is necessary to divide this large voltage into a number of smaller voltages for use in the timing circuit described in the next chapter. As mentioned before,<sup>7-10</sup> any group of resistors, like *R1*, *R2*, *R3* and *R7* in Fig. 16*F* which permits a large voltage to be split into smaller parts is called a *voltage divider*. To know better how the d-c timing circuit works<sup>17-2</sup> and how to check and service this circuit,<sup>22-5</sup> the normal voltages across each part of a voltage divider should be known. These voltages are not given on complete diagrams like Figs. 15*D* or 15*E*. However, if the ohms of each part of the divider circuit are given, the voltage across each part or resistor is easily figured.

In Fig. 16*F*, for example, the ohms in *R1*, *R2*, *R3* and *R7* are given. Add these values together, giving a total of 3700 ohms. Since we know that the total voltage across these four resistors is 320 volts, by using the formula  $E = I \times R$  (from Sec. 2-7) the current *I* flowing through these resistors is figured

$$I = \frac{E}{R} = \frac{320 \text{ volts}}{3700 \text{ ohms}} = 0.086 \text{ amp}$$

Multiply each separate resistance by this 0.086 amp to get the volts across that resistance. Across *R7*, there is 500 ohms  $\times$  0.086 amp = 43 volts. This means that there is a difference of 43 volts d.c. between point 36 and

point 21. This also means that point 36 is 43 volts more positive than point 21, or that point 21 is 43 volts more negative than point 36. Similarly, by calculating that the voltage across *R2* is  $600 \times 0.086 = 52$  volts, it is seen that the movable contact shown by the arrow under *R2* can change the voltage at point 40 through a range of 52 volts.

Knowing the normal voltages across these resistors, as shown in Fig. 16*F*, helps to find trouble in the circuit. Suppose a voltmeter shows only 10 volts across *R7*; this resistor may be partly shorted. If there is no voltage across *R7*, then *R7* may be completely shorted, or the circuit through this voltage divider is open. To find this, first connect the voltmeter from 21 to 22, to be sure the 320-volt supply is normal. Keeping one voltmeter lead on 21, touch the other lead to 31, and the voltmeter may still read 320 volts. When touched to 32, the voltmeter may read zero, showing that the circuit is open between 31 and 32. *R2* is open, or one of its contacts is faulty.

It is emphasized that there can be no difference in voltage between two ends of a good resistor, unless there is current flow through the resistor. A voltage divider cannot properly split the voltage across it unless the circuit is complete through all the resistors that make the voltage divider.

## CHAPTER 17

### FIRING THE IGNITRONS; THE POWER CIRCUIT

The portions of the synchronous spot-weld timer which provide a-c and d-c control voltages have been discussed. The main power circuit will be studied next to see how the ignitron tubes are controlled by the thyatron tubes that fire them. No direct current is used in this circuit, but a-c line voltage is connected to all four tubes, as shown near the center of the complete diagram of Fig. 15E.

**17-1. Connection of Ignitrons.**—The power circuit of an accurate welder control uses a pair of ignitron tubes and a pair of thyatron tubes to fire or start the ignitrons. The use and arrangement of these four tubes is the same in most kinds of synchronous welder control, as shown in the simple circuit of Fig. 17A. Here the ignitrons are connected together in the same way as in the ignitron contactor shown in Fig. 3D. The anode of one ignitron connects to the cathode of the other ignitron. This connection is called *back-to-back* or *inverse parallel*. However, Fig. 17A shows the igniters or starters of these tubes connected in a different way. Each ignitron is started by a current of 15 or 20 amp flowing into its starter, but this starting current is fed into the igniter by a thyatron, which acts as a firing tube. The anode of this thyatron is connected to the same voltage as the anode of its ignitron. This means that thyatron tube 5 is connected in parallel with the anode of ignitron tube 7. The anodes or tops of both tubes 5 and 7 become positive at the same instant, and also become negative together, but there is this difference: the ignitron cannot pass current first, but must wait for the thyatron to pass current, and this current then ignites or fires the ignitron. In turn, the thyatrons are controlled by their grid voltages *A* and *B*, but these are here assumed to be positive, permitting the thyatrons to fire whenever they have proper anode voltage.

In Fig. 17A, when line 2 is (+), welder current tries to flow from line 2, through the welding transformer to 3, down through

ignitron tube 7 to line 1. Current cannot flow yet through tube 7, but thyatron tube 5 passes current from 3 into the igniter of tube 7. Assuming there is at least 40 amp load current,<sup>4-11</sup> tube 7 fires and passes this current. Similarly, during the next half-cycle (below the 0-0 line) when line 1 is (+), welder current tries to flow from line 1, through tube 8, through the welding transformer to line 2. Again the current must flow first through thyatron tube 6, and this current then fires ignitron tube 8, which passes current for the rest of that half-cycle. Current

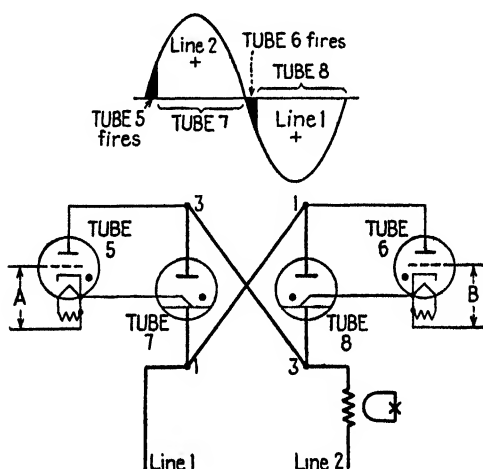

FIG. 17A.—Ignitrons with firing thyratrons.

flows through the thyatron for only a very small part of each cycle because, as soon as the ignitron starts to pass current, the voltage across the ignitron suddenly decreases to the amount of the arc drop (15 volts, see Sec. 3-9), which is too small to force current through the thyatron. As soon as the thyatron finishes its job of starting the ignitron, the thyatron stops passing current. Of course, these changes happen so fast that, to the eye, the thyatron seems to be passing current all during the weld. A scope<sup>4-15</sup> shows the difference.

Each thyatron acts also as a rectifier and passes current in one direction only. This prevents any flow of current through the starters in the reverse direction, which would damage the starters.

**17-2. The Power Circuit.**—The part of the control equipment that carries the main current to the welder is called the *power circuit*. This circuit is shown in Fig. 17B, where the grid circuits of tubes 5 and 6 are also shown, as they are used in the spot-weld timer of Fig. 15E. Except for these grid circuits, Fig. 17B shows the exact arrangement of ignitrons with their firing thyratrons that is used in most synchronous welder controls. These tubes work together, as described above and in Fig. 17A. Tubes 5 and 7 can pass current only when line 2 is (+); tubes 6 and 8 can pass current only when line 1 is (+); neither ignitron can pass current until its thyatron passes current. Since the thyratrons completely control the starting of the ignitrons, and since these thyratrons are controlled by their own grid voltages, it is plainly seen that the ignitrons 7 and 8 are controlled by whatever happens in the grid circuits of thyratrons 5 and 6. These grid circuits will be studied later.

The anode current of thyatron tube 5 passes from point 3 through fuse *F5*, resistor *R17*, and contacts of *CR2* relay, from anode 76 to cathode 71 of tube 5, into the starter of tube 7, to line 1. *F5* is a 3-amp fuse used<sup>3-9</sup> to protect the starter (igniter) and tube 5 from being overloaded if the ignitron tube 7 fails to pass current. *R17* is a 4-ohm resistor, used to limit the amount of current that can flow through tube 5 if the resistance of the igniter of tube 7 should become much less than 5 or 10 ohms. Without *R17* resistor, the life of tube 5 may be decreased. The 4 ohms of *R17* is needed only with a power supply of 440 volts or more. At 220 volts, only 1 ohm resistance is needed, so *R17* is built with a tap connection, which is not used at 440 volts but which is connected to terminal 77 when the power supply is 220 volts. This shorts 3 ohms, leaving only 1 ohm in circuit. The *CR2* contact is closed by the d-c coil of *CR2* contactor<sup>16-10</sup> when all conditions are safe for welding. However, if the water supply fails or if someone accidentally opens the control power switch or if the operator opens his safety switch, this *CR2* contact quickly opens, preventing tube 5 from passing current to fire tube 7.

In the same way, thyatron tube 6 is protected by *F6*, *R18* and another *CR2* contact. Tube 6 passes current only long enough to start tube 8. If tube 8 refuses to pass current, fuse *F6* may blow after several cycles. However, if each weld is only 1- or 2

cycles long, current may not flow for a long enough time to blow the fuse. This failure of tube 8 is shown by extra-bright blue flashing in tube 6. When a thyatron tube is firing more brightly than usual, the trouble is probably not in the thyatron, but in the ignitron that it fires.

The filaments of thyatron tubes 5 and 6 are heated by windings of the *T5* transformer. These firing tubes are heated at 5.5 volts (higher than rated filament voltage) so as to provide greater electron emission<sup>9-12</sup> to carry the large momentary currents needed to fire the ignitrons. Tubes 5 and 6 are shield-grid

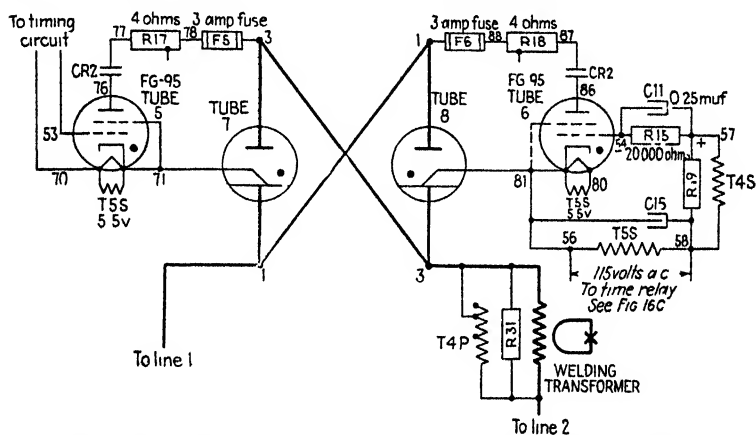

FIG. 17B.—Power circuit of spot-welding control (CR7503-A124)

thyatrons<sup>8-13</sup> having sensitive grid control. Since these shield grids are “tied” (solidly connected) to the tube cathodes at 71 and 81, they do not control these tubes and need no further mention.

The grid-to-cathode capacitors *C5* and *C6* have been previously explained.<sup>9-13</sup>

**17-3. Voltage and Current in Power Tube Circuit.**—It is helpful to know how the voltage and current are changing in the power circuit just described. The steady wave shapes of a-c line voltage and current are shown<sup>14-4</sup> in Fig. 14*B*. These curves appear again in *a* of Fig. 17*C*, which shows current flowing during a 2-cycle weld (starting at the power-factor angle). While this welder current is flowing, *b* shows the changes of voltage across the ignitron tubes and *c* shows the changes of

voltage across the welder transformer. At every instant, the sum of welder voltage + ignitron voltage = line voltage.

In Fig. 17C, current starts to flow at *A*. This causes the voltage across the ignitron tube 7 to decrease suddenly to the 15-volt arc drop at *B*, while at the same time voltage appears across the welder at *C*. At *D* the line voltage crosses the 0-0 line, so the welder voltage also becomes negative at *F*. Notice that

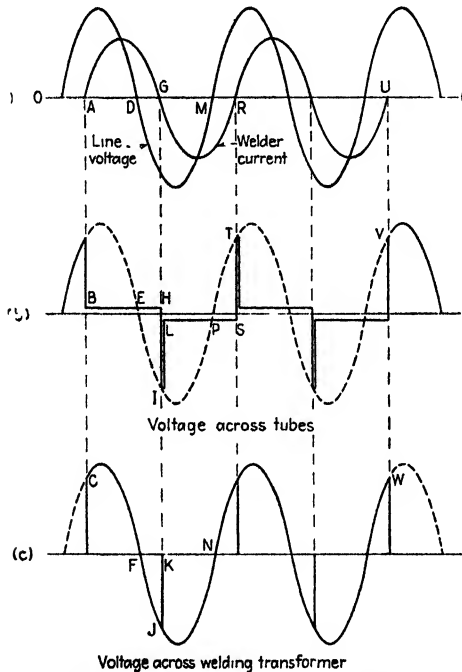

FIG. 17C.—Welder and ignitron voltages during weld.

no change in voltage occurs across tube 7 at *E*, since the same 15-volt arc drop continues as long as current flows. At *G* the current through tube 7 becomes zero. At this instant, the arc drop disappears at *H*, and full line voltage of the right polarity to force current through tube 8 appears at *I*. The voltage across the welder transformer decreases suddenly from *J* to *K* (mentioned again in Sec. 17-5). The voltage at *I* forces current through thyatron tube 6 (only when the grid of tube 6 is positive), and this fires tube 8. The passing of current decreases the

voltage across ignitron tube 8, dropping from  $I$  to the arc drop  $L$ , and voltage returns across the welder at  $J$ . As line voltage again crosses the 0-0 line at  $M$ , welder voltage reverses also ( $N$ ), but there is no change in the arc drop of tube 8 at  $P$ . At  $R$  the current through tube 8 becomes zero, so the arc drop disappears, and full line voltage appears at  $T$ , which forces current through tubes 5 and 7 when tube-5 grid lets it do so. This passage of current through tube 7 starts the second cycle of current flow, which repeats all the above steps. At  $U$  the current through tube 8 again becomes zero, ending the second cycle. Immediately full line voltage appears across tubes 5 and 7 at  $V$ , but this time the grid of tube 5 is not positive and does not let tube 5 start another cycle. The 2-cycle weld is finished and the voltage across the welder suddenly decreases from  $W$  to zero.

**17-4. Grid Control of Firing Thyratrons.**—A thyatron that is used to fire an ignitron or to pass the current that starts an ignition is called a *firing tube*. Tubes 5 and 6 are firing tubes. These tubes do another job besides just firing the ignitron or power tubes. (As will be seen in Sec. 19-3, tubes 5 and 6 are sometimes controlled by a special phase-shift grid circuit, so as gradually to change the heat of the welding transformer.) In the spot-weld timer of Fig. 15*E* and the circuit of Fig. 17*B*, tubes 5 and 6 also control the order in which the ignitrons fire. Tube 5 always starts the weld by first firing ignitron tube 7; then tube 6 finishes that cycle by firing ignitron tube 8. The grid circuit of tube 6 never lets tube 6 start a weld, for it always waits for a signal that tube 5 has fired first. Also, tube 5 can never fire alone without making tube 6 fire also. The arrangement of two thyratrons in this way is called the *leading-tube-trailing-tube circuit*. Tube 5 always leads or starts the weld. Tube 6 always trails, or finishes, the weld. With this arrangement, the timer cannot pass welding current for times such as  $1\frac{1}{2}$ ,  $2\frac{1}{2}$  or  $5\frac{1}{2}$  cycles. A  $1\frac{1}{2}$  cycle weld consists of 3 half-cycles. Tube 5 carries the 1st and 3d half-cycles. Tube 6 carries the 2d half-cycle, and cannot keep from passing the 4th half-cycle also, which makes a total of 2 cycles instead of the  $1\frac{1}{2}$  cycles attempted.

There is no objection to a  $1\frac{1}{2}$ -cycle weld, or to a  $5\frac{1}{2}$ -cycle weld. However, such a weld is both started and finished by the same tube. If this is done by tube 5, then it becomes necessary to start the next weld with the other tube 6, to prevent the



possibility of transient currents.<sup>14-9</sup> Instead of starting a weld with whichever tube did not pass the last half-cycle of the preceding weld, it is usually more practical to start every weld with the same leading tube and always end each weld with the other or trailing tube.

**17-5. Firing the Leading Tube.**—As just described, tube 5 in Fig. 17*B* is the leading tube, for it is always the first tube to pass line current, closely followed by its ignitron tube 7. The starting of tube 5 is completely controlled by the voltage between its grid 53 and its cathode 70. From these points, notice that wires are connected to the timing circuit above, but there are no similar connections from tube 6 up to the timing circuit. The two wires 53 and 70 are the only connections between the d-c synchronous-timing circuit and the a-c power circuit. When the signal is given to start to pass welding current, this signal finally reaches the power circuit only through the grid circuit of tube 5. If for any reason tube 5 fails to pass current, neither tube 7 nor tube 6 nor tube 8 will fire. However, when this signal from above does make grid 53 more positive than 70, so that tube 5 can pass anode current, tube 5 instantly fires ignitron tube 7, which passes welder current during the rest of that half-cycle. Just as the current through tube 7 stops flowing, the signal is given to tube 6 to carry on and pass the trailing half-cycle. To show how this signal makes tube 6 respond, the grid circuit of tube 6 is given next.

**17-6. Grid Circuit of Trailing Tube.**—The grid voltage that controls tube 6 is the voltage between grid 54 and cathode 81. As shown in Sec. 7-11, the grid voltage of a tube is made up of all the voltages in the circuit connecting the grid to the cathode. In Fig. 17*B*, starting with cathode 81, the grid circuit passes from 56 through *T5S* to 58, through *R19* to 57, then through *R15* to grid 54. This means that the voltages across *T5S*, *T4S* and *R15* all have a part in controlling tube 6. It was previously shown<sup>16-2</sup> that the primary of transformer *T5* is energized whenever control voltage is connected to the equipment. Therefore, there is always voltage across *T5S* (56 to 58) which is the same 115 volts used to operate the *TR1* time relay.<sup>16-4</sup> However, the primary of transformer *T4* is connected across the welding transformer; therefore no voltage is produced by *T4S* (58-to-57), except when the welding transformer is energized. Except when

a weld is being made, *T5S* is the only source of voltage in this grid circuit of tube 6.

**17-7. The Grid Bias.**—In Fig. 17*B*, *T5S* is connected so that the potential at point 58 is out of phase with the anode potential (at 86) of tube 6. This means that the 58 end of *T5S* is (+) when anode 86 is (-). At such time, tube 6 cannot pass anode current. During the half-cycle when anode 86 is (+) and is able to pass current, the 58 end of *T5S* is then (-); this also makes the grid of tube 6 negative, and the negative voltage keeps tube 6 from firing. Figure 17*D* explains these conditions, show-

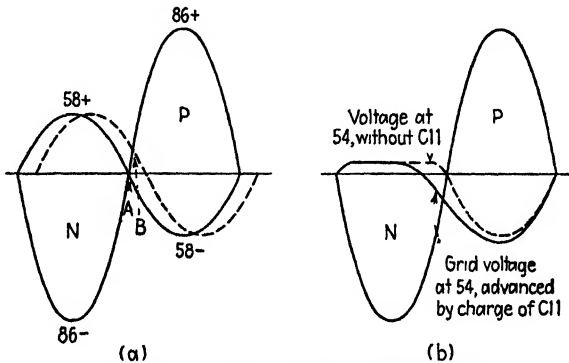

FIG. 17*D*.—Hold-off bias on trailing tube.

ing that tube 6 has positive voltage on its anode during half-cycle *P*, but with grid voltage negative during this same time, preventing tube 6 from firing. The grid voltage is exactly\* out of phase with the anode voltage, and the grid voltage becomes negative at the same instant *A* when the anode becomes positive.

But see what will happen if some sudden surge causes the voltage of *T5S* to lag slightly, as shown by the dotted line in *a*. This lets the anode voltage become positive at *B*, while the grid is still positive. This is enough to fire tube 6 at the wrong time. Such surges can happen, so something must be added in the grid circuit to prevent this faulty operation of tube 6. This explains the need for *R15* and *C11* shown in Fig. 17*B*. Tracing this complete grid circuit, when anode 86 is (-) and 58 is (+), the voltage

\* The anode voltage of tube 6 is also the a-c supply voltage. *T5S* is made exactly out of phase with the anode voltage by using capacitor *C15* to offset the inductive current of *T4*.

of *T5S* forces a small current through *R19* to *57*, through *R15* to grid *54*, and through tube *6* to cathode *81* and back to *T5S*. As this small current passes through the 20,000 ohms of *R15*, it produces more than 50 volts drop across *R15*, making grid *54* more negative than *57*. Capacitor *C11* charges up to this voltage across *R15*. During the next half-cycle *P*, when the grid of tube *6* is negative, the rectifying action<sup>7-18</sup> of the grid prevents current from reversing through this grid circuit, so *C11* holds its charge, although discharging through *R15* during the next half-cycle. Figure 17*D* shows in *b* that this charge on *C11* makes the voltage at grid *54* become negative *before* the anode voltage becomes positive.\* It is said that *C11* holds a *negative bias* on the grid of tube *6*, to prevent tube *6* from firing.

**17-8. Firing the Trailing Tube.**—Before a weld is started, it is seen that tube *6* is kept from firing because of the out-of-phase or “hold-off” potential produced by *T5S* and the negative grid bias of *C11*. To make tube *6* fire, it is necessary to make grid *54* positive by producing a “turn-on” voltage in *T4S*, which opposes *T5S*. The “turn-on” voltage of *T4S* is large enough to overcome or be greater than the “hold-off” voltage of *T5S*. *T4P* is connected across the welding transformer, and tube *6* fires only when *T4P* has been energized. When the leading tube *5* starts a weld, ignitron tube *7* passes the first half-cycle of current into the welding transformer. Figure 17*C* shows the resulting voltage (*C* to *F* to *J*) across the welding transformer, which is also across *T4P*. When current through tube *7* stops at the end of this first half-cycle, the sudden change in voltage (from *J* to *K*) causes a quick current change in *T4P*, which then produces the “turn-on” voltage in *T4S*, which fires tube *6* and makes ignitron tube *8* start to carry current during the second half-cycle of the weld.

**17-9. The Leading-tube-trailing-tube Circuit.**—Summarizing, Fig. 17*B* shows the firing tubes *5* and *6*, whose grid circuits let them fire the ignitrons only in the proper order. The d-c timing circuit of the synchronous control connects only to the grid of tube *5*, which always fires first to start the weld. Meanwhile, tube *6* is kept from firing by the voltage of *T5S* and the bias

\* The grid voltage does not become more than 15 or 20 volts positive, since the arc drop or constant voltage drop through the tube limits the grid voltage to this amount.

of *C11*, charged by grid rectification. When tube 5 starts ignitron 7, welder current flows for the first half-cycle. At the end of this half-cycle, the feedback transformer *T4* makes tube 6 fire ignitron 8, to pass current for the second half-cycle. Tube 5 will again fire the third half-cycle, and the tubes continue this flow of welding current until the grid of tube 5 is made negative by the d-c timing circuit. The trailing feature of tube 6 makes sure that each weld will have an even number of half-cycles of current flow. The control of only one tube by the timing circuit decreases the load on this sensitive d-c circuit and makes it possible to use a pair of unmatched firing tubes.

## CHAPTER 18

### THE SYNCHRONOUS TIMING CIRCUIT

The most important part of the synchronous spot-weld timer is the circuit that starts each weld at the same point on the voltage wave and also times the length of the weld. This circuit is near the top of the complete diagram of Fig. 15E.

**18-1. Synchronous Circuit Arrangement.**—In the timing circuit shown in Fig. 18A, thyatron tube 2 provides synchronous starting, which is so necessary for an accurate and short-time weld. The length of the weld is determined by capacitor C2, together with the adjustable tapped resistor R9. Everything that happens in Fig. 18A serves only to control tube 5, which then controls the other tubes as shown in the previous chapter. All parts of the circuit of Fig. 18A operate from the various d-c voltages obtained from the voltage divider R1, R2, R3 and R7, described in Sec. 16-11. None of these voltages appear until TR1 closes (28-to-22) at the end of the 5-min heating time.

The sensitive relay CR1 is energized by the 70 volts between 31 and 22 whenever the starting-switch contact is closed. This contact is not the foot switch, but is a contact operated by a sequence timer or pressure switch or cam after the electrodes are tight together. The welding current starts almost instantly after CR1 operates its contacts, shown to the right of tube 2. Tube 2 cannot pass anode current until after CR1 closes its normally-open contact 47-to-48, and then only when its own grid circuit will let it, as shown below. When tube 2 fires, current flows from 22 through R10 to 48, through CR1 contact and tube 2, to point 36 on the voltage divider. Current is forced through this circuit by about 277 volts d-c pressure. Since tube 2 is a thyatron (gaseous tube) operating in a d-c circuit, its grid 46 has control of the instant when tube 2 starts to pass current, but thereafter the grid has no effect<sup>8-5</sup> and tube 2 continues to pass current, with a blue glow, until the starting contact is released and CR1 opens its contact 47-to-48.

Since the purpose of all this d-c circuit is merely to control tube 5, it is now time to see what voltages are applied to the grid 53 and the cathode 70 of tube 5. Trace from grid 53 through protective resistor  $R14$  to 40A, and through resistor  $R54$  to point 40, which is an adjustable slider on  $R2$  of the voltage divider. The voltage at 40 is about 90 volts below or more negative than at point 22, the most positive point in the whole d-c circuit. The grid of tube 5 remains always about 90 volts

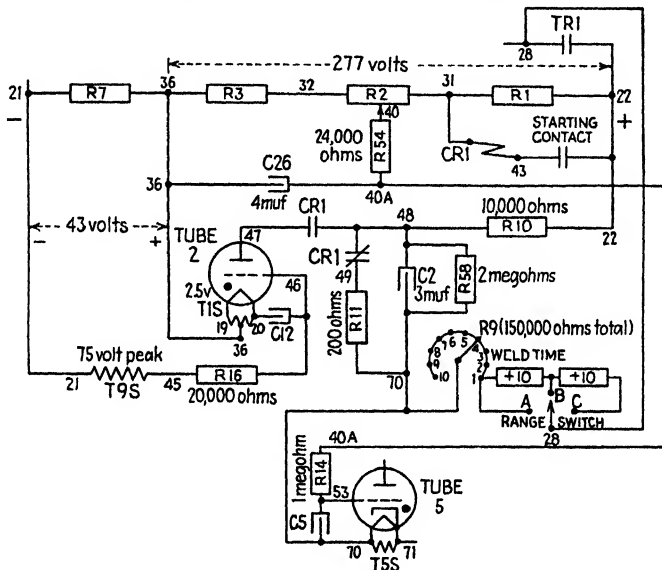

FIG. 18A.—Timing circuit of spot-welding control (CR7503-A124).

below the voltage at 22. The cathode 70 of tube 5 is connected to the bottom of capacitor  $C2$ , and through the  $R9$  resistors to point 28, which is at the same potential as 22. Before welding, or when tube 2 is not passing current, points 70 and 48 are at the same potential as 22, since there is no current flowing through  $R9$ ,  $R10$  or other parts of the timing circuit. Therefore cathode 70 is at the same potential as 22, but grid 53 is at the potential of point 40, or about 90 volts more negative than 22. Since the grid is 90 volts more negative than the cathode, tube 5 cannot fire. It is the beginning of current flow through tube 2 that really starts tube 5 (as shown in Sec. 18-3) and thereby starts the flow of welding current. For this reason tube 2 is sometimes

called the *keying* or *triggering tube*, for it gives the trigger impulse that fires or starts the weld. Naturally, the grid circuit of tube 2 receives next attention.

**18-2. Grid Circuit of Tube 2.**—As shown in Fig. 18A, the cathode of tube 2 is connected to point 36 of the voltage divider while the grid 46 is connected through  $R16$  and transformer  $T9S$  to point 21, which is the most negative voltage of the divider. Across  $R7$ , which separates cathode 36 from point 21, there is 43 volts d.c.

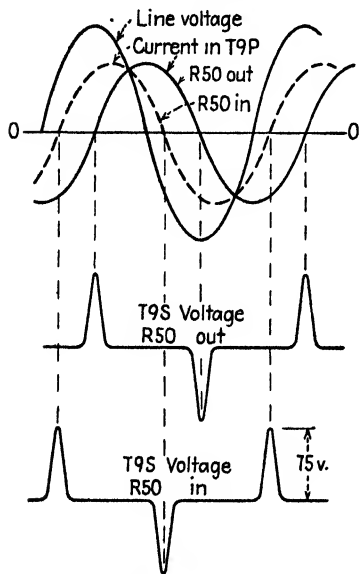

FIG. 18B.—Voltage peak for firing tube 2.

When transformer  $T9$  is not producing any voltage between 21 and 45, the grid 46 is being kept negative by this 43-volt negative bias, which keeps tube 2 from passing current. The only way to fire tube 2 is to energize transformer  $T9$  so that  $T9S$  will produce a “turn-on” voltage greater than the 43-volt “hold-off” grid bias.

The “turn-on” voltage produced by  $T9S$  is not a smooth “sine-wave” curve such as most transformers give, but is a pointed peak wave as shown in Fig. 18B. This unusual wave shape is obtained by purposely designing transformer  $T9$  with so little iron in its magnetic circuit that this iron saturates during most of each cycle and produces secondary voltage during only 10 degrees out of every 180 degrees. This is explained further in Sec. 20-7, where several kinds of “peakers” or peaking transformers are described. Figure 18B shows that these voltage peaks of  $T9S$  are very narrow and are about 75 volts high. During each cycle there is one positive peak and one negative peak. Whenever  $T9S$  produces a positive peak, this 75-volt peak overcomes the 43-volt “hold-off” bias across  $R7$  and makes the voltage positive at grid 46. This instantly fires tube 2, which in turn fires tube 5 and starts the weld. Whenever the positive peak of  $T9S$  occurs, that is the only instant when a

weld can start. Since this peak is only 10 degrees wide, each weld is started always within this 10-degree range. *T9S* is connected into circuit so that its positive peak fires tube 2 sometime during the same half-cycle when tube 5 can fire.

As mentioned in Sec. 16-2, the instant at which this positive *T9S* peak occurs can be adjusted by moving the slider of resistor *R50*, which is in series with *T9P* (see Fig. 16A). As shown in Fig. 18B, if very little of *R50* is left in circuit with *T9P*, the current in *T9P* lags nearly 90 degrees or  $\frac{1}{4}$  cycle behind the line voltage, and this makes the peak voltage of *T9S* start tube 2 much later than (or to the right of) the line voltage. This is about the right point on the voltage wave to start a welder with long arms or large reactance (a low-power-factor welder of, say, 20 per cent power factor). However, moving the slider on *R50* toward 94 inserts more resistance in the circuit with *T9P*, making the primary current of *T9* come closer in phase with the line voltage and producing the voltage peak of *T9S* earlier in each cycle. This fires tube 2 and starts the weld at an earlier point on the voltage wave, about right for a high-power-factor welder, such as one of 60 or 70 per cent power factor.

**18-3. Starting Each Weld in Step.**—The narrow voltage peaks of *T9S* are occurring during every cycle, so the grid of tube 2 is made positive once each cycle. Although its grid becomes positive, tube 2 cannot fire or pass current until its anode circuit is closed by *CR1* contact. Therefore, to make a weld, the starting contact is first closed, energizing *CR1*, which closes contact 47-to-48. (This is quite like closing a line switch ahead of a magnetic contactor.) As shown in Fig. 18D, just closing this *CR1* contact does not fire tube 2 or start welding current. During the first positive half-cycle after *CR1* has closed, the peak voltage of *T9S* fires tube 2 at the right point on the voltage wave, and always at the same point, one weld after another. When *CR1* and tube 2 complete the circuit from 48 to 36, there is a difference of only 15 volts between points 48 and 36, for this is the amount of the arc drop or voltage across tube 2. Subtracting these 15 volts from the total of 277 volts between points 22 and 36, it is seen that there must now be about 262 volts across *R10*. Therefore, when tube 2 passes current, the voltage at point 48 drops to 262 volts below the potential at 22, or to 172 volts below the potential of point 40 (since 40 is 90



volts below 22). At this same instant, the voltage at point 48 is also the voltage at point 70, or the cathode of tube 5. (There is no voltage drop across capacitor *C2* at this instant, for *C2* had been shorted through *R11* and the normally-closed contact of *CR1*.) Therefore, at the exact instant when tube 2 first passes current, the voltage at cathode 70 takes a nose dive down to a new value which is about 262 volts more negative than point 22, or 172 volts below point 40, the grid voltage of tube 5. This is the same as saying that grid 53 has suddenly become 172 volts more positive than cathode 70, so tube 5 fires instantly.

**18-4. Timing the Weld.**—To learn how long tube 5 is permitted to fire and cause welding current to flow, first see what happens to capacitor *C2* and how it controls tube 5. At the instant when tube 2 fires and causes 262 volts to appear across *R10*, capacitor *C2* starts to charge to this same voltage. *C2* connects to the negative end of *R10* at point 48. The other end of *C2*, at point 70, is connected through resistor *R9* to point 28, which is at the same potential as the positive end of *R10*. Direct current charges *C2*, by flowing through the adjustable resistance of *R9*. *R9* includes a 10-step dial selector, together with a 3-position range switch, which are mounted on the front door of the control, to permit selection of the desired length of spot weld. As shown in Fig. 18A, a 1-cycle weld is obtained by turning the *R9* dial to position 1 and keeping the range switch connecting 28 to *A*. This setting removes all *R9* resistance from the circuit, so that *C2* is charged directly from the positive terminal 28, at the fastest rate. For a 2-cycle weld, the *R9* dial is moved to position 2, which adds into the circuit a 5000-ohm resistor, connected between positions 1 and 2. This added resistor decreases the current that charges *C2*, so *C2* takes a longer time to charge. As *C2* charges, the increasing voltage across *C2* raises the voltage at 70 closer to the positive voltage at point 28. (By the time *C2* has fully charged, there is no more current flowing through *R9*, so the entire 262 volts between 22 and 48 now appears across *C2*.) Raising the voltage of 70 finally makes the voltage of tube-5 cathode become more positive than the grid of tube 5. When this happens, tube 5 completes the current flow for cycle 2, which is then passing, but its grid prevents tube 5 from starting cycle 3. The weld is now ended.

Notice that tube 5 is controlled by keeping its grid constant at the voltage of point 40A, while its 70 cathode which (a) was more positive than the grid before the weld starts, (b) suddenly becomes more negative than the grid to start the weld and (c) is gradually raised back, again becoming more positive than the grid, to end the weld. This operation is shown in Fig. 18C, where a straight line shows the constant grid voltage of tube 5, while its cathode suddenly drops from A to B, then is pushed up to C, and returns to its starting potential. At C the cathode voltage becomes more positive than the grid voltage, so tube 5 cannot start any additional cycle after this point. The starting contact is shown closing almost a whole cycle before the weld

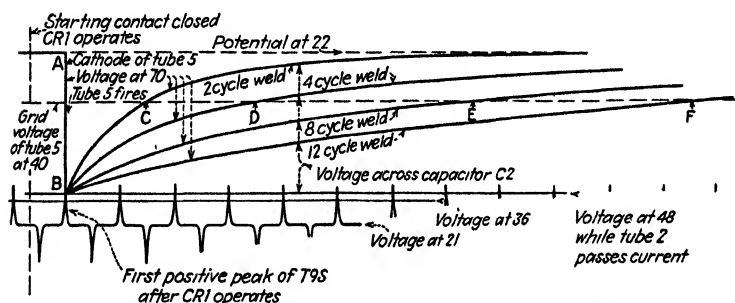

FIG. 18C.—Changes of voltage that control the leading tube.

starts. The fact that the weld does not start immediately, but waits for the next positive voltage peak of T9S so as to start the weld at the right point of the voltage wave, is the vital feature of synchronous-timing control. For a 4-cycle weld, turning the R9 dial to position 4 inserts several more steps of resistance in the charging circuit of C2. At this decreased charging rate, Fig. 18C shows that C2 raises the voltage of cathode 70 more slowly, until at D the grid of tube 5 can start no more cycles. Similarly, with R9 dial set for 8 cycles, capacitor C2 charges still more slowly, and tube 5 cannot start cycles later than E. (Any cycle that tube 5 has already started is completed by the trailing-tube action of tube 6.) For a 12-cycle weld, the range switch is turned to connect 28 to B. This adds a 50,000-ohm resistor, which alone causes a 10-cycle increase in timing. The extra 2 cycles, to give a total of 12, are obtained by moving the R9

dial back to position 2. With this setting, Fig. 18C shows that *C2* is charged much more slowly, so that 12 cycles pass by before the voltage of cathode 70 reaches the grid voltage at *F*. For a 30-cycle weld, the range switch connects 28 to *C*, and the *R9* dial is set to position 10, inserting the whole resistance of *R9* and giving the slowest charging rate for *C2*.

When tube 5 cannot pass more cycles, and the weld is ended, tube 2 still passes current as long as the starting contact remains closed. After *C2* is fully charged, the only current passing through tube 2 is the current flowing through *R10*. When the starting contact opens, dropping out *CR1*, this opens the circuit through tube 2, but *CR1* then closes its n-c contact 48-to-49, and capacitor *C2* quickly discharges through *R11*, to get ready for the next weld.

**18-5. Completing the Circuit.**—Several small circuit parts need explanation, including the reason why the positive end of the *R9* resistor is connected to point 28, instead of direct to point 22. During the 5-min warming period, while the *TR1* contact is open between 28 and 22, cathode 70 of tube 5 is kept positive by being connected through *R9* to point 28. Meanwhile, grid 53 is kept negative, through points 40 and 21. These connections prevent tube 5 from firing, regardless of any unusual conditions.

Capacitors *C12* and *C5* are protective grid-to-cathode capacitors,<sup>9-13</sup> which do not usually affect the circuit operation. *R16* and *R14* are protective grid resistors to limit the current flowing when the grid is positive.

Capacitor *C26* and *R54*, just below the voltage divider, help prevent false operation of tube 5 if the a-c line voltage dips or changes suddenly. The sudden a-c voltage dip also decreases the d-c voltage between 22 and 21 and permits a voltage dip at point 40 (grid voltage of tube 5), giving short erratic timing. However, the large 4- $\mu$  f capacitor *C26* prevents sudden changes of the voltage between 40A and 36, thereby keeping most line-voltage disturbances from reaching the grid-cathode circuit of tube 5. With constant voltage at 40A and a changing voltage at 40, *R54* takes up the slack.

Resistor *R58* is connected across *C2* only to correct the small timing error caused by the grid current of tube 5 during a weld. With *R58* in use, the entire group of *R9* resistors can be more easily adjusted or calibrated by only the one slider at point 40.

While all the timing circuit of Fig. 18A operates on d.c., still every part of this circuit is also "hot" with a.c., because of the connection to the cathode of tube 5 at point 70, which is connected to one side of the a-c power supply.

**18-6. Timing Circuit of Other G.E. Controls (B7, B11, A100, A106, A109 Types).**—As shown in Fig. 18C, the length of the spot weld is adjusted in the present CR7503-A124 panel of Fig. 18A by changing the amount of resistance  $R_9$  and controlling the rate at which  $C_2$  charges. The grid of tube 5 remains constant at the voltage of point 40.

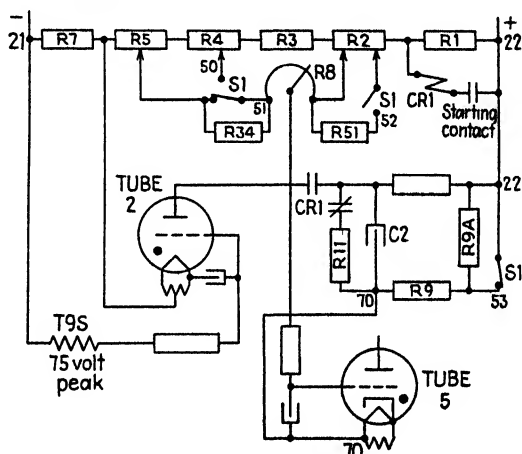

FIG. 18D.—Timing circuit (CR7503-B7D, -A100, etc.).

Earlier controls (such as CR7503-B7A, -B7D, -B11, -A100, -A104, and -A109 types) provide adjustment of the length of spot weld by changing the voltage to which  $C_2$  must charge before the weld will stop. The timing circuit of these controls is shown in Fig. 18D, where the time length of weld is adjusted by potentiometer  $R_8$  together with range switch  $S_1$ .  $S_1$  is shown in the low-range position, which permits  $R_8$  to select a weld length between 1 and 15 cycles. To change to the high range, 16 to 30 cycles, all  $S_1$  contacts move at once, connecting to points 50 and 52, but opening at 53.

The rest of Fig. 18D is the same as Fig. 18A. The voltage divider  $R_1$ -to- $R_7$  has more and different units, but gives small d-c voltages in the same way. The starting contact energizes  $CR_1$ , which completes the anode circuit of tube 2, which fires

as soon as the next positive peak voltage of *T9S* makes its grid positive. Current through tube 2 suddenly reduces the potential at *C2*, which takes cathode 70 down with it, firing tube 5. In Fig. 18*E*, this voltage at cathode 70 is shown positive at *A*, until it drops to *B*, firing tube 5 and starting the weld. Immediately *C2* starts to charge at one of two rates. If *S1* is set for low range, the *S1* contact at 53 is closed, shorting *R9A*. Only the resistance of *R9* limits the current flowing from 22 into *C2*, so *C2* charges quickly, along curve *BCDEF* of Fig. 18*E*. However, with *S1* set for high range, the charging current must flow from 22 through both *R9A* and *R9*, so *C2* charges more

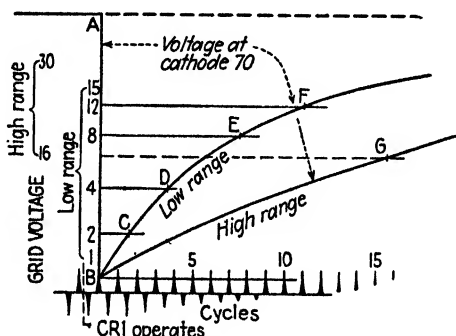

FIG. 18*E*.—Variable-grid-voltage control of leading tube.

slowly, along curve *BG*. So far, this time adjustment is similar to that in Fig. 18*C*. However, to adjust for a 2-cycle weld, the slider of *R8* is turned to touch near the 51 end. The voltage at this slider is the same as at the grid of tube 5, so turning the slider toward 51 reduces the d-c voltage at the grid. As shown in Fig. 18*E*, this grid voltage is so low that it is very quickly reached and passed at *C* by the rising cathode voltage as *C2* charges. As soon as the voltage of cathode 70 becomes higher than the grid voltage, tube 5 starts no more cycles of welding current. For a 4-cycle weld, *R8* is now turned away from 51, raising the grid voltage to a higher level *D*, which cathode 70 reaches only after *C2* has charged for a longer time. Similarly, 8- or 12-cycle welds are obtained by turning *R8* farther, raising the d-c voltage of the grid still higher, so that *C2* must charge longer and raise cathode 70 up to *E* or *F*. Note that *C2* charges at the same rate

as before, but charges to a higher voltage level before controlling tube 5.

When *S1* is changed to high range, capacitor *C2* charges more slowly, and two other contacts of *S1* reconnect potentiometer *R8* so that it selects grid voltages in a higher d-c range. For a 16-cycle weld, *R8* is turned to the 51 end, but this is now a higher grid voltage than before. Charging at its slower rate, *C2* takes about 16 cycles before it raises the voltage of cathode 70 up to *G*, the new voltage of the grid.

By controlling the grid-cathode circuit of tube 5 in this way, the ignitron tubes are also controlled, as shown in the previous chapter. The a-c and d-c supply circuits of these panels are also very similar to those already described.

**18-7. Westinghouse Spot-weld Control (SP-11).**—The circuit of the type SP-11 synchronous spot-welding control is similar in many ways to the G.E. controls already described, but the main features typical of Westinghouse controls are described here. As shown in Fig. 18*F*, the SP-11 control has a-c supply and d-c supply circuits much like those of Fig. 16*A* and part of Fig. 16*F*. The power circuit of the ignitrons with their firing thyratrons is nearly the same as Fig. 17*B* and uses the leading-tube-trailing-tube circuit. In the timing circuit, the synchronous-starting feature consists of an impulse transformer, firing tube 2 in the same manner as shown in Fig. 18*A*. The length of the weld is timed by the charging of a large condenser *C4*. However, getting beyond these points of similarity, it will be noticed that the SP-11 control uses five heated tubes instead of four. The familiar tubes are the 83 rectifier, the pair of WL-632 thyratrons used for firing the ignitrons and the KU-627 thyatron tube 2 used to start the weld. The fifth tube is the other KU-627 tube 4, whose purpose is to turn off or end the weld after the desired number of cycles.

Before describing this different timing circuit, the method of obtaining the d-c "hold-off" bias should be mentioned.

**18-8. Negative Bias by "Rectox."**—From the right-hand side of Fig. 18*F*, looking at the grid circuit of trailing tube 5, which fires ignitron *R*, it is seen that tube 5 is normally kept from firing by the negative bias produced by transformer winding *T1S* together with Rectox 1 and capacitor *C1*. This 40-volt a-c winding of *T1S* can force current in only one direction through

the copper oxide rectifier (Rectox 1), and this charges  $C1$  positive on the side toward cathode 44 of tube 5 and negative on the 10 side, which keeps the grid of tube 5 negative. Tube 5 can fire only when this negative voltage across  $C1$  is overcome by the voltage of the grid transformer connected across the primary winding of the welding transformer, (as described in Sec. 17-8).

In the same way, tube 2 is normally kept from firing by the negative voltage produced by another  $T1S$  winding, together with

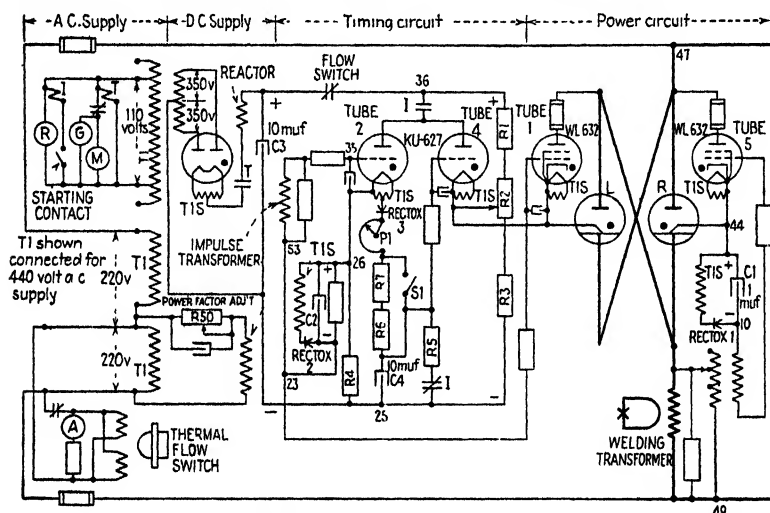

FIG. 18F.—Westinghouse synchronous spot-welding control (Type SP-11).

Rectox 2 and capacitor  $C2$ . Here again current from  $T1S$  can flow through Rectox 2 only in the one direction which charges  $C2$  so that it is negative on the 23 side; this keeps grid 35 of tube 2 negative. Point 23 is about 50 volts more negative than point 26. Tube 2 fires, to start the weld, only at the instant when the impulse transformer produces a positive voltage peak that overcomes the negative bias of  $C2$ , making the grid of tube 2 positive. As described in Sec. 18-3, tube 2 is fired by the first positive impulse peak after the starting contact has energized contactor  $I$ , which applies d-c anode voltage to tube 2.

**18-9. Timing Circuit of SP-11 Control.**—Before  $I$  closes at the start of a weld, no thyratrons are passing current, so all parts of the circuit beneath tube 2 are at the negative potential of point 25. The timing capacitor  $C4$  has no charge or voltage, and it is

shorted through *R5* by the normally closed contact of *I*. The upper end of *C4* is also at the potential of the grid of tube 4, which is therefore also at the negative potential of point 25. However, the cathode of tube 4 is connected to the slider on *R2*. The voltage divider, made by *R1*, *R2* and *R3*, causes the potential at *R2* to be more than 100 volts more positive than at point 25, so the grid of tube 4 is this much more negative than tube-4 cathode, preventing tube 4 from firing. The slider on *R2* is also at the cathode potential of the leading firing tube 1, whose grid is connected to point 23, which is about 50 volts more negative than point 25 because of the 50-volt bias voltage of *C2*. To trace the complete grid circuit of tube 1, start at tube-1 cathode or the slider on *R2* and trace down through *R3* to point 25, through *R4* to point 26, then down across *C2* to point 23, to the right and up to the grid of tube 1.

When the starting contact energizes *I*, tube 2 fires to start the weld at the right point on the a-c voltage wave, as determined by the next positive voltage peak of the impulse transformer. Since tube 2 is a gaseous tube operating with d-c anode voltage, it continues to pass current as long as *I* remains closed. With current flowing through tube 2, the voltage at its cathode 26 suddenly rises to within 15 volts of the positive point 36, and a large voltage appears across *R4*. This rise in voltage at 26 also carries the voltage of point 23 up with it. Although 23 still remains 50 volts below 26 (because of *C2*), point 23 is made more positive than the slider of *R2*; this is the same as making the grid of tube 1 more positive than its cathode, so tube 1 fires instantly when tube 2 fires. Note that tube-1 grid is still 65 volts more negative than point 36 because of arc drop in tube 2 and the bias of *C2*.

Current through tube 2 passes also through Rectox 3, time-adjusting potentiometer *P1*, *R7*, *R6* and gradually charges capacitor *C4*. The time required to charge *C4* and end the weld is made shorter as *P1* is turned, decreasing its resistance, or as range switch *S1* is closed, shorting *R7* and *R6*. As *C4* charges, voltage gradually appears across *C4*; this forces the upper side of *C4* to become more positive, making the grid of tube 4 more positive also. After the desired time delay (length of weld). *C4* has charged enough to raise the grid voltage of tube 4 to be more positive than its cathode, so tube 4 fires, to end the weld.



This tube 4 does by raising the potential of *R2* slider up to within 15 volts of the positive point 36 (because 15 volts is the arc drop or voltage difference between anode and cathode of tube 4 when passing current). In this way, *R2* slider (cathode of tube 1) again becomes more positive than point 23 (grid of tube 1), so tube 1 is prevented from starting additional cycles of welding current.

Summarizing, in Fig. 18*F*, tube 2 fires at the power-factor angle of the weld, and immediately fires tube 1 by raising the potential of tube-1 grid about 40 volts above tube-1 cathode. Current through tube 2 also charges *C4*, which times the weld by gradually raising the grid voltage of tube 4 until tube 4 finally fires; this makes tube-1 cathode potential again more positive than tube-1 grid, preventing tube 1 from passing additional cycles. Meanwhile tube 1 is followed in order by ignitron *L*, tube 5 and ignitron *R*, as described in Sec. 17-9.

#### 18-10. Weltronic Synchronous Welder Timer (Model 51).—

The circuit of this synchronous spot-welding control is shown in Fig. 18*G*. The a-c and d-c supplies are obtained in about the same way as in controls already studied (See Secs. 16-1 and 16-6).

Eleven tubes are used, including two ignitrons. Tube *V1* is the full-wave rectifier,<sup>16-7</sup> *V3* is the triggering tube (like tube 2 in Sec. 18-1), *V2* and *V5* are the leading and trailing tubes<sup>20-2</sup> which control *V6* and *V7* and make them fire the ignitrons. Rectifiers *V8* and *V9* supply d-c hold-off bias on tubes *V6* and *V7*. Tube *V3* is triggered by a voltage peak from *T15S* and starts tube *V2*, much like the circuit<sup>18-1, 18-6</sup> in Fig. 18*D*. This voltage peak of *T15S* is produced by the firing of tube *V4*, as next described.

When tube *V4* is not passing current, capacitor *C2* is being charged by direct current flowing from positive point 22, through *R9* into *C2*, and to 21, the negative side of the d-c supply. During this time, the grid of tube *V4* is negative. However, potentiometer *R20* is set\* so that, at the correct point on the a-c voltage wave, the grid of thyatron *V4* becomes positive and *V4* passes current. Most of this current is caused by *C2*, which quickly discharges through *T15P* and tube *V4*. This sudden

\* The circuit of *T7S*, *C4* and *R20*, which phase-shifts or selects the proper point for starting the weld, can be understood better after reading Chapter 19.

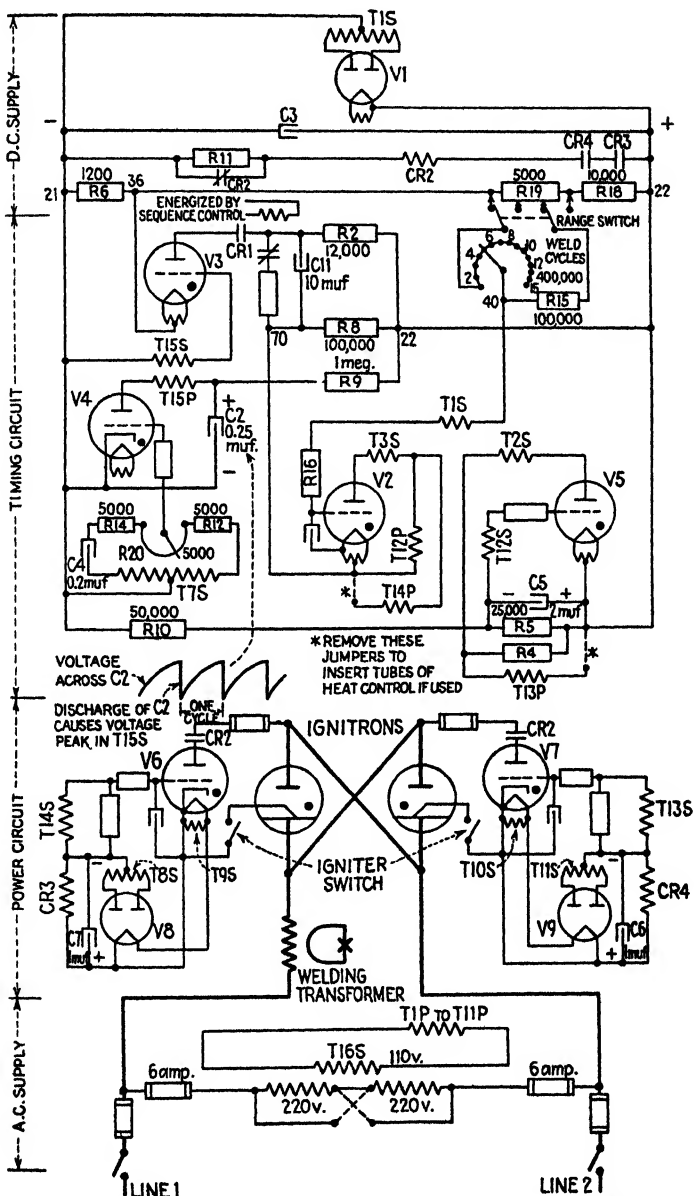

FIG. 18G.—Weltronic synchronous spot-welding control (Model 51).

discharge of current through *T15P* causes a narrow voltage peak in *T15S*. When *C2* has discharged, the anode voltage of tube *V4* is so low (slightly negative) that the current stops flowing in *V4*, and its negative grid regains control. Capacitor *C2* now charges in less than one cycle, and is ready to discharge when the grid of *V4* again swings positive. This action is pictured in Fig. 18G (center); it produces a "sawtooth" voltage wave shape across *C2* and causes a voltage peak in *T15S* once each cycle.

To make a spot weld, relay *CR1* must be energized by an outside contact, such as in a sequence control. Before *CR1* picks up, its normally-closed contact is shorting *C11*, and its other contact is open, so point 70 (cathode of *V2*) is at the same potential as point 22. The grid of *V2* is connected to the "weld cycles" dial, all parts of which are more negative than point 22, so tube *V2* cannot fire. When *CR1* picks up, and closes the circuit between *C11* and the anode of *V3*, then *V3* is fired by the next voltage peak of *T15S*. The firing of *V3* makes point 70 become nearly as negative as point 36. Since this is more negative than any part of the "weld cycles" dial, the grid of *V2* is now able to fire *V2*. However, the timing capacitor *C11* is now being charged (current from 22, through *R8* to *C11*, through *CR1* contact and *V3* to 36), and its increasing voltage is raising point 70 closer to positive point 22. When 70 reaches the potential of the "weld cycles" contact (40), then *V2* cannot start another cycle, and that weld is finished.

When *V2* fires, *T3S* forces current through *V2*, *T12P* and *T14P*. This current in *T14* makes tube *V6* fire, as shown later. At the instant current stops flowing in *V2* and *T12P*, the sudden decrease in voltage across *T12P* causes tube *V5* to fire, for the resulting *T12S* voltage is greater than the hold-off d-c bias across *R5* and *C5*, which had been keeping the grid of *V5* negative. So *V5* fires during every half-cycle after *V2* has fired the preceding half-cycle, giving leading-tube-trailing-tube action.<sup>20-2</sup> The current through *V5* causes *T13* to fire *V7*.

In the power circuit, the circuit of *V6* is exactly like the circuit of *V7*. When the igniter safety switch and the *CR2* contacts have been closed, *V6* will fire its ignitron tube as soon as the grid of *V6* becomes positive. Between welds, the grid of *V6* is kept negative by the d-c bias across *C7*. Rectifier *V8* passes current which charges *C7* so it is negative on the side toward the grid of

V6. If V8 should fail, V6 could fire at the wrong time. To prevent this, relay CR3 is picked up only when there is correct bias voltage across C7. The CR3 contact helps complete the circuit to CR2 relay, whose contact is in the anode circuit of V6.

When V2 energizes T14P, the voltage of T14S is greater than the voltage across C7, so the grid of V6 is made positive, and V6 fires its ignitron tube. Similarly, when V5 energizes T13P, the voltage of T13S "turns on" V7, which fires its ignitron.

**18-11. Summary of Spot-welding Timers.**—This completes the discussion of the synchronous spot-welding control begun in Chap. 15. Other spot-welding timers have additional features<sup>20-10</sup> and are used for seam welding<sup>23-5</sup> or are designed for special jobs<sup>26-1</sup>, but they all include most of the circuit parts that have been described. The controls already described give all the advantages of synchronous timing, which is possible only by the use of electron tubes throughout. The use of ignitron tubes in the welder circuit also makes possible the very desirable feature of phase-shift heat control, which is to be discussed next.

## CHAPTER 19

### CONTROL OF WELD HEAT BY TURNING A DIAL

When a welding machine is controlled by a contactor, or by any of the electron-tube equipment already described, it is still necessary to adjust the amount of welding current and heat at the weld. This is usually done by changing tap connections on the welding transformer. However, whenever tubes are used to pass the current to the welder, these tubes can be controlled in such a way as to change the heat at the weld, merely by turning a dial on the control panel.

**19-1. Changing Weld Current and Heat.**—Remembering from Sec. 14-2 that the heat in the weld depends on the welding current, the weld resistance and the length of time of current flow, it is seen that a good way to decrease the weld heat is by decreasing the welding current. Of course, this is done by decreasing the voltage produced in the secondary winding of the welding transformer. To make possible such changes in weld heat, most welding transformers have taps on their primary windings, as shown in *a* of Fig. 19A. If the tap switches are set on tap 1 and range 1, line voltage is connected across the whole primary winding. This gives the lowest heat in the weld because the least voltage is produced in the secondary circuit of the welder, as shown in curve *A*. If changed to tap 3, range 2, line voltage is connected across only part of the primary winding. This produces larger secondary voltage (curve *B*) and increased heat in the weld. Moving the tap switches to tap 4 and range 4 connects line voltage across just a small part of the welding transformer winding, so the secondary voltage is very large (curve *C*), producing the hottest weld. As every welder operator knows, these tap switches must not be changed while the machine is welding, for opening such a current-carrying circuit causes injury and damage.

It is possible to set a welding transformer on highest heat (tap 4, range 4), as shown in *b* of Fig. 19A, and then decrease the heat by inserting resistance *R*. With the slider of *R* at *a*, all the

resistance of  $R$  is in circuit, so only a small part of the line voltage ever reaches the welding transformer. The secondary voltage is small, as in curve  $A$ . As the slider is turned toward  $c$ , the voltage across the welding transformer winding increases, giving greater secondary voltage until curve  $C$  is reached. Such a resistance  $R$  wastes too much electricity to be practical.

Although most resistance welders are regulated by changing taps, the tube control of such welders gives another way to regulate the weld heat. For example, if a pair of vacuum tubes is used, large enough to pass the line current to the welder, it is

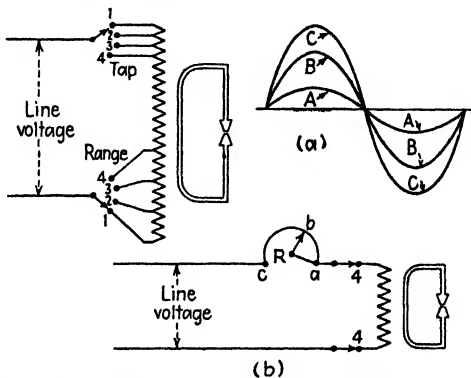

FIG. 19A.—Weld heat changed by transformer taps.

possible to control the grid voltage of such tubes<sup>8-5</sup> so as to change the voltage gradually at the welder. This works quite like resistance  $R$  above, and causes changes of welder voltage like curves  $A$ ,  $B$  and  $C$  in Fig. 19A. However, such high-current vacuum tubes cannot be obtained, so that is out. But how about using high-current ignitron tubes in such a way as to regulate the amount of voltage that reaches the welder? Remember that an ignitron is a gaseous tube, whose amount of current flow cannot be controlled by the igniter. When the tube starts to pass current, the amount of anode current is limited only by the external load. It is not possible to control ignitron tubes so as to get different smooth voltage curves like those shown in Fig. 19A. Nevertheless, thousands of ignitrons are now being used to regulate the welder heat gradually, so let us see how this is done.

**19-2. Using Only Part of Each Cycle.**—Ignitron tubes can be made to regulate the welder heat by letting the ignitrons pass

current during only a part of each cycle. This is possibly a new thought to many, since most a-c equipment like motors, lights or furnaces uses current during whole cycles and cannot select or use just a part of any cycle. Even ignitron tubes, as used in the ignitron contactor or synchronous controls of preceding chapters, pass current during whole cycles, as shown in Fig. 17C. However, these same ignitron tubes can be controlled by a special circuit which delays the starting of each tube until some later point in the cycle. Figure 19B shows the a-c line-voltage wave, and also the full wave of welder current that flows when the ignitrons are fired at points A (as described in Sec. 17-3). How-

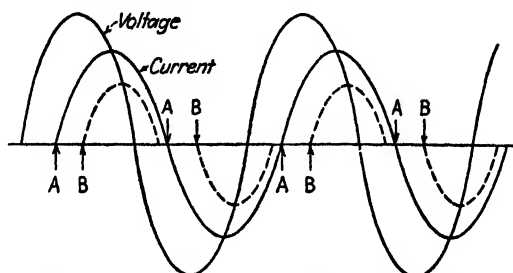

FIG. 19B.—Welding current flowing for part of each cycle.

ever, if the ignitrons are not permitted to fire until point B in each half-cycle, then the current does not start to flow until B. The dotted line shows the resulting wave of current flow. It is seen that no current flows during the portion between A and B, so no heat can be produced at the weld during this part of each cycle. The load of the welding machine determines the amount of current that passes through the ignitrons during any whole cycle, but the ignitrons can be made to pass this current for only part of each cycle, thereby changing the heat at the weld. A single weld is made by the total heat produced by current flowing during a number of cycles, so it makes little difference whether this heat is produced by large current flowing during only part of each cycle or by smaller current flowing during all of each cycle.

If the current through a pair of ignitrons passes directly to a load such as an oven or large bank of lights, which is entirely a resistance load, then the full-wave current is in phase with the voltage, as shown by the solid line in a of Fig. 19C. The curves of current and voltage cross the 0-0 line together.

If the ignitrons are now made to delay the starting of current through this load, until point *B* in each half-cycle, the current then instantly rises to its normal curve and flows the rest of each half cycle, during the entire shaded portion. If the ignitrons do not start current flow until point *C*, the current again follows a vertical line to its normal curve and then flows during the more heavily shaded portion of each cycle. The current can make these sudden changes because this load circuit includes no reactance. In contrast, when these same ignitrons pass current into a welder load, the reactance<sup>14-6</sup> of the welder circuit prevents the current from making sudden changes. Instead, if the ignitrons start to pass current at *D* in *b* of Fig. 19C,

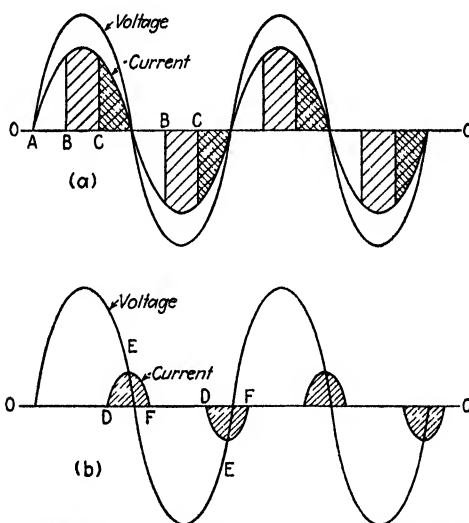

FIG. 19C.—Phase-shift in (a) resistance circuit and (b) reactance circuit.

the current increases more slowly. Before the current can rise to its normal curve, the voltage at *E* has become so small that it cannot force the current to increase further. Meanwhile, some energy has been stored in the inductance of the welder, which forces the current to continue to flow until *F*, some time after the voltage has crossed below the 0-0 line.

**19-3. Phase-shift Heat Control.**—Any pair of ignitron tubes can be made to give delayed starting during each cycle of current flow, so as to regulate the amount of heat in the weld. The special circuit or equipment that controls the ignitrons in this way is called a *heat-control* circuit, and it generally includes a pair of thyatron tubes to fire the ignitrons. Since these thyatrons are controlled by changing or shifting the phase of their



grid voltages, this whole circuit is commonly called a *phase-shift heat control*. Later chapters describe complete synchronous-control equipments for spot or seam welders, which include this phase-shift heat-control circuit. However, this heat control is also furnished separately, for use with an Ignitron Contactor or Weld-O-Trol, and it can be added to synchronous controls of types already described. This separate phase-shift heat-control equipment is studied in this chapter.

**19-4. Heat Control with Ignitron Contactor (CR7503-D116 or -D137).**—As shown in Fig. 19D, a pair of thyratrons can be used to control the ignitron contactor in Fig. 3D by connecting

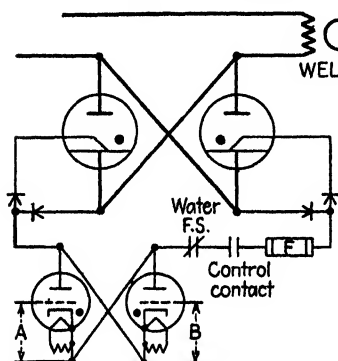

Fig. 19D.—Thyratrons added to ignitron contactor.

the thyratrons back-to-back in the igniter circuit. The ignitrons can fire only during those cycles when the control contact is closed. In addition, the thyratrons let the ignitrons fire only the last part of each of these cycles, when the grid circuits connected to A and B "tell" the thyratrons to do so.

The complete elementary circuit of a phase-shift heat-control panel is shown in Fig. 19E, together with the ignitron contactor to which it is added. Notice that the ignitron contactor in the lower part of the diagram will operate by itself if the two points A are connected together. In order to add the heat-control panel, connections are made to points A, and transformer T5 needs a supply of a-c control power which must be from the same phase that supplies the welder.

This heat-control panel mounts two FG-95 thyatron tubes, 5 and 6, connected to the ignitrons in the same way as in Fig. 19D. The filament heat and "hold-off" grid voltage for these thyratrons are supplied by transformer T5. Since these thyratrons must be warmed 5 min before starting the weld, this heat-control equipment includes a time-delay relay TR1, which is motor-operated as described in Sec. 16-4. This TR1 is supplied at 115 volts from taps on T5P, and the mercury-button contact<sup>16-5</sup> is in the igniter circuit A-A.

Voltage taps on *T5P* supply a phase-shifting circuit, whose main parts are *R30*, *C13* and *T2P*. Adjustable resistor *R30* controls the weld heat by making the a-c voltage across *T2P* more out of phase with the line voltage as *R30* resistance is

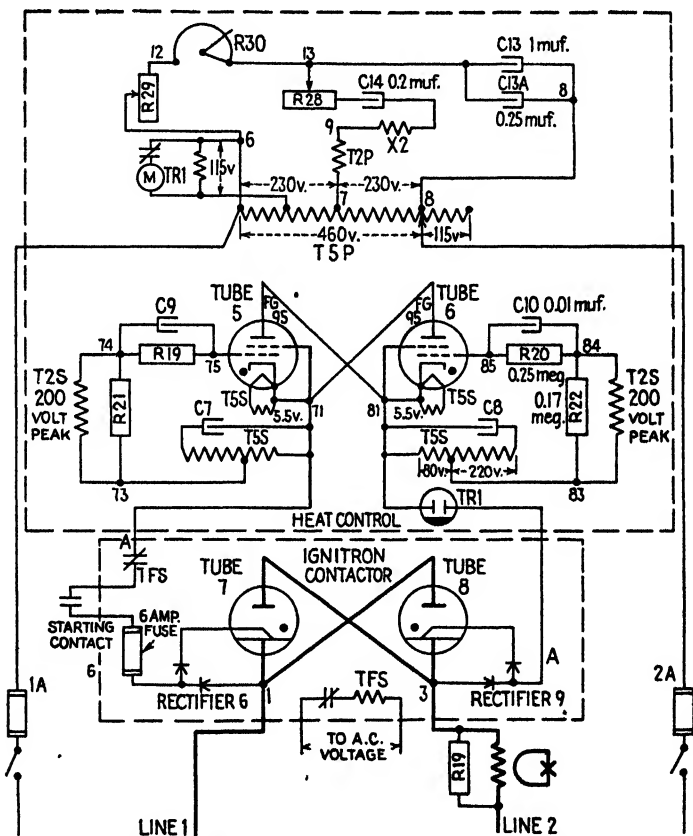

FIG. 19E.—Circuit of ignitron contactor and heat control (CR7503-D137).

increased. Transformer *T2* is the connecting link between this phase-shifting circuit and the thyatron-tube circuits below, for the *T2S* windings furnish peak voltages that make tube 5 and 6 fire the ignitrons.

**19-5. Thyatron Grid Circuits in Heat Controls.**—In Fig. 19E it is seen that the complete grid circuit of tube 5 has parts like

those of the grid circuit of tube 6, just as though the tube-5 circuit were a mirror reflection of the tube-6 circuit. The *T2S* and *T5S* windings in tube-5 grid circuit are just like the *T2S* and *T5S* windings in tube-6 grid circuit. *R19* and *R20* are alike, and so are *C9* and *C10*, or *R21* and *R22*. Either one of these two duplicate circuits is also quite like the grid circuit of trailing-tube 6 in Fig. 17*B*, described in Sec. 17-6. However, in Fig. 19*E* neither tube 5 nor tube 6 is a leading tube or a trailing tube. Since they have duplicate or identical grid circuits, tube 5 and tube 6 have equal chances of being the tube that starts the weld after the starting contact is closed. From the way this heat control is shown connected to the ignitron contactor, it is seen that thyatron tube 5 can fire only ignitron tube 7, while tube 6 is the one that fires tube 8. For example, when line 2 is (+), the current flows up through the welding transformer to 3, but cannot yet flow through tube 7, so it flows through rectifier 9 and *TR1* contact to 81, down through tube 5 to point 71, through *TFS* contact, starting contact and fuse to rectifier 6, and into the starter of tube 7, to line 1. This fires tube 7, which then passes current directly from 3 to line 1. The voltage between 3 and line 1 decreases to 15 volts arc drop, which is not enough to continue to force current through the tube-5 circuit, so tube 5 goes out for the rest of that cycle.

To discover what grid voltage keeps tube 5 from firing, or makes it fire at any desired point in the voltage wave, trace the complete grid circuit starting at cathode 71, through *T5S* to 73, through *R21* to 74, through *R19* to grid 75. During the half-cycle when tube-5 anode is positive, the 80-volt\* a-c winding *T5S* is negative at its 73 end, which also makes grid 75 negative, so that tube 5 cannot fire. As previously described<sup>17-7</sup> and shown in Fig. 17*D*, grid 75 is also biased negative by the charge on *C9*, which *C9* receives from the voltage across *R19* when current flows from *T5S* through *R21*, *R19* and the grid-cathode circuit of tube 5, during the half-cycles when tube 5 anode is negative. The resulting voltage at point 75, the grid of tube 5, is shown in Fig. 19*F*.

\* The whole *T5S* winding produces 300 volts a.c., but only 80 volts is taken from a tap connection for use in this circuit. Later,<sup>20-3</sup> when this same equipment is used to add heat control to a synchronous tube-controlled welder, the entire 300 volts will be required.

Transformer T2 produces narrow voltage peaks in its T2S windings, and it is these peaks that make tubes 5 and 6 fire. (Transformer T2 is a peaking transformer, whose special design is discussed in Sec. 20-6.) While the grid voltage of tube 5 is made as much as 125 volts negative by T5S and C9, the T2S voltage peaks are 200 volts high, so the tube-5 grid voltage becomes positive (above the 0-0 line) only during the narrow

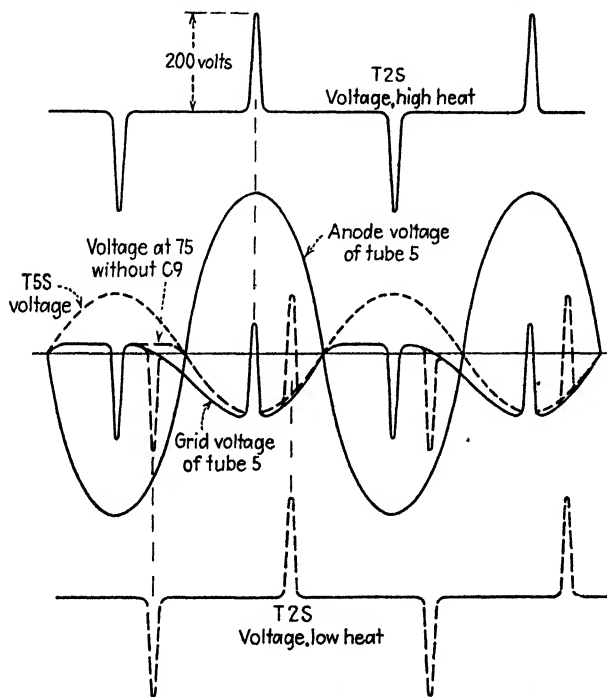

FIG. 19F.—Grid voltage of phase-shifting thyratrons.

10-degree width of this voltage peak. This voltage peak makes tube 5 fire; so, if the position of this peak is delayed until later in the cycle, tube 5 fires later and makes ignitron 7 pass welding current for a smaller remaining part of the cycle. Figure 19F shows how these T2S peaks occur earlier in each cycle when high heat is needed at the weld, but are made to occur later to give lower heat.

The position of these T2S voltage peaks is not changed or adjusted within transformer 2. As in any other transformer,

these secondary voltage peaks always remain the same distance behind the primary voltage curve. Therefore, to see what does move these peaks earlier or later in the cycle, look to the circuit that controls the primary voltage of transformer 2.

**19-6. Diagrams Showing Phase Shift.**—The operation of the phase-shifting circuit at the top of Fig. 19E (and later in the lower portion of Fig. 20A) is best understood by first using only *R30*, *T2P*, *C13* and *T5P*, in a similar arrangement shown in

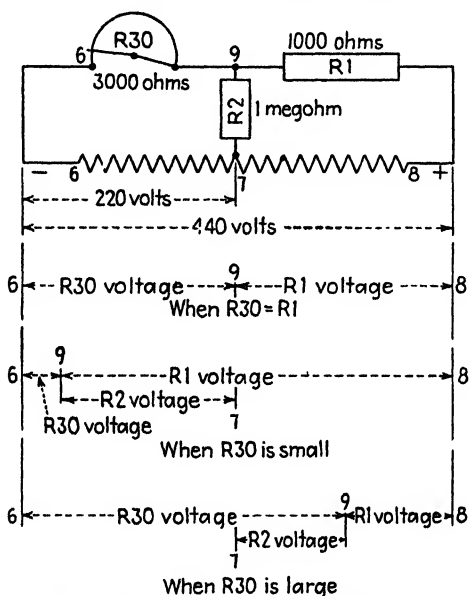

FIG. 19G.—Shifting voltages by all-resistance circuit.

Fig. 19J. However, before studying this a-c circuit with its capacitor, resistor and transformer, see what happens in the similar circuit of Fig. 19G, where resistors  $R_{30}$ ,  $R_1$  and  $R_2$  are connected together in the same way, across 440 volts.  $R_2$  is purposely made very large (1,000,000 ohms), so that the current through  $R_2$  is too small to consider. Therefore, the same amount of current flows through  $R_1$  as flows through  $R_{30}$ . Now, if  $R_{30}$  is turned until only 1000 ohms of its resistance is left in circuit, this resistance is the same as  $R_1$ , so the current produces the same voltage drop across each. There is 220 volts across  $R_{30}$  between points 6 and 9, and also 220 volts between 6 and 7, so there is no

voltage across  $R_2$ . Now, if  $R_{30}$  is turned to the position shown, where perhaps 100 ohms is still in circuit, then the current increases through both  $R_1$  and  $R_{30}$ . Most of the 440 total volts now appears across  $R_1$ , and only about 20 volts across  $R_{30}$ . Point 9 is 20 volts from point 6, so there must be  $220 - 20 = 200$  volts across  $R_2$ . Notice that, at a time when point 7 is more positive than point 6, then 9 is more negative than 7, so the voltage across  $R_2$  is out of phase with the 440 line voltage.

Similarly, if  $R_{30}$  is turned until all its 3000 ohms is in circuit with the 1000 ohms of  $R_1$ , then three-quarters of the 440 total

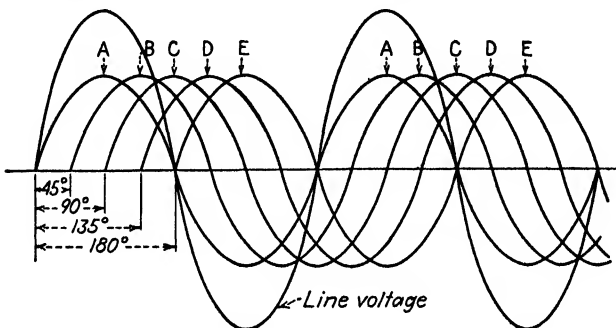

FIG. 19H.—Curves of voltage-phase changes.

volts appears across  $R_{30}$ . When point 7 is more positive than 6, point 9 is 330 volts more positive than point 6, or 110 volts more positive than point 7, so 110 volts appears across  $R_2$  in phase with the 440 line voltage. From this example, it is seen that changing  $R_{30}$  also changes the voltage across  $R_2$  from  $-200$  volts to 0 and to  $+110$  volts. This resistor circuit can change the amount of voltage across  $R_2$ , but this voltage is either in phase or completely out of phase with the line voltage 6 to 8. This circuit cannot gradually change the voltage from in-phase to out-of-phase, as is needed for heat control.

The combination of resistor  $R_{30}$  and capacitor  $C_{13}$  in Fig. 19J makes it possible to change the phase of voltage across  $T_2P$  gradually. This change of voltage phase is shown in Fig. 19H, where the  $T_2P$  voltage is shown (A) in phase with line voltage, (B) 45 degrees out of phase, or lagging 45 degrees behind line voltage, (C) 90 degrees out of phase with line voltage, (D) 135 degrees out of phase, and finally (E) 180 degrees or completely out of phase with line voltage. (Of course,  $R_{30}$  can be adjusted

to give any desired phase angle in between these angles shown in Fig. 19H.) These phase angles can also be shown by the diagram of Fig. 19I (called a *vector diagram*), in which any voltage is shown by a straight line. The amount of voltage is the length of the line, but the phase is shown by the direction of the line. The 0-0 line is used as the direction of the line voltage, and any

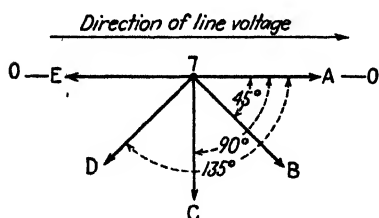

FIG. 19I.—Vector diagram of voltage phase angles.

other voltage that is exactly in phase with the line voltage is drawn in the same direction, as from 7 to A. A voltage exactly out of phase is also drawn along the same line, but the arrow is at the opposite end, as from 7 to E, showing that voltage 7-to-E is opposite to the line voltage.

Between these two extremes, a voltage lagging 90 degrees behind the line voltage is shown, as 7-to-C. This 7-to-C line is "behind" the line voltage, because the arrows are thought of as swinging up to the 0-0 line. The arrow 7-to-B has to swing upward only 45 degrees before it reaches the 0-0 line, so the voltage 7-to-B is lagging only 45 degrees behind the line voltage. Similarly, the arrow 7-to-D must swing through 135 degrees of angle before it can catch up to the line voltage, or 0-0 line, so 7-to-D is lagging 135 degrees behind the line voltage. This 7-to-D arrow represents the same condition as shown by curve D in Fig. 19H. The phase of the voltage of T2P must be shifted in this same way to change the weld heat.

### 19-7. The Phase-shifting Circuit.

Coming now to Fig. 19J, mentioned earlier in this section, it is seen that the 440 volts a.c. forces current from point 8, through C13 and R30, to point 6. [Only that half-cycle when 8 is (+) and 6 is (-) is now being considered.] This same current produces a voltage drop across C13 and across R30, but these two voltage drops are out of phase with each other. Although the voltage across resistance R30 is in phase with the current that produces it, the voltage across

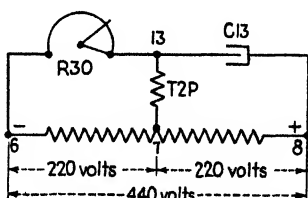

FIG. 19J.—Simplified resistor-capacitor phase-shifting circuit.

capacitor  $C13$  is 90 degrees out of phase with this same current. This is the way any capacitor behaves naturally; that is, the current flowing into the capacitor is 90 degrees ahead of the voltage. In other words, the voltage across a capacitor lags 90 degrees behind the current. [To show that this is right, remember that, in blowing up a balloon, the air goes into the balloon faster when the pressure in the balloon is very low. By the time the air pressure becomes large, and the balloon is at full size, air is going very slowly into the balloon and stops flowing at maximum pressure. The most air flows (like electric current) while the lung pressure is increasing (while voltage changes most rapidly near the 0-0 line), but air stops flowing (or current is zero) when the lung pressure becomes steady at its highest value (greatest voltage).]

In Fig. 19K the voltage across  $R30$  is always between points 6 and 13, while the capacitor voltage is between points 13 and 8. Notice that the capacitor voltage line is always perpendicular (or at an angle of 90 degrees) to the resistor voltage line. The voltage across  $T2P$  is always shown by the arrow between points 7 and 13. This arrow is always the same length, showing that

the amount of voltage across  $T2P$  does not change while the phase is being changed. As the arrow of  $T2P$  voltage changes direction, the direction of arrow 7-to- $S$  remains always opposite to it, for the latter represents the corresponding position of the secondary voltage produced by  $T2S$ , which is the peak voltage that makes tubes 5 and 6 pass current.

In *a* of Fig. 19K, circuit conditions are shown while low heat is being produced at the welder. The slider of  $R30$  is touching at

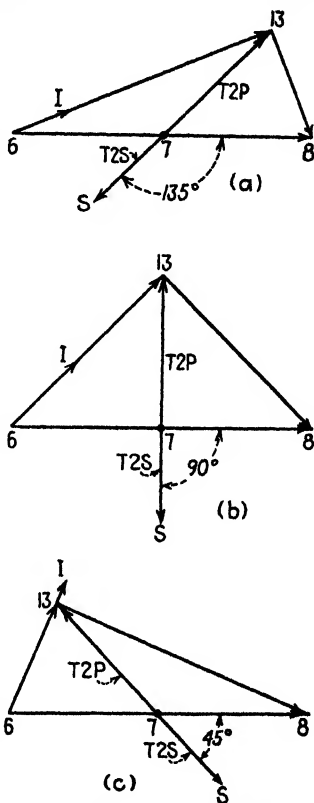

FIG. 19K.—Phase angles of peaking-transformer voltages.



point 13, so all of  $R30$  is in circuit. There is much greater voltage drop across  $R30$  than across  $C13$ , so point 13 is closer to the 8 end of the line-voltage arrow. As a result, the  $T2S$ -voltage arrow is pointing in a direction nearly opposite to that of the line-voltage arrow, showing that  $T2S$  is lagging about 135 degrees, like the voltage lags in  $D$  of Fig. 19H or 19I. As  $R30$  is turned, shorting out part of its resistance, greater weld heat results. With unchanged capacity ( $C13$ ) but less resistance, the current  $I$  through this circuit leads the line voltage still more;  $b$  of Fig. 19K shows that the voltage drop across  $R30$  is now about equal to the drop across  $C13$ , but these voltages are still at 90 degrees to each other. The voltage across  $T2P$  between points 7 and 13 is about 90 degrees out of phase, and the  $T2S$  voltage, 7-to- $S$ , now lags only 90 degrees behind the line voltage. Similarly,  $c$  of Fig. 19K shows still less resistance in  $R30$  and greater voltage drop across  $C13$ , and the  $T2S$  voltage is now lagging only 45 degrees behind the line voltage. This 45-degree angle corresponds to a welder power factor of 70 per cent, so the resistance in this phase-shifting circuit rarely needs to be decreased further, since these conditions in  $c$  will give 100 per cent heat in most welders.

Having seen how the phase angle of  $T2P$  is changed by turning the slider of  $R30$ , now examine the complete circuit at the top of Fig. 19E.\* The extra capacitor  $C13A$  merely combines with  $C13$  to give the total desired capacity of 1.25  $\mu$  f. The resistor  $R29$  is furnished so that, even when  $R30$  is shorted out completely by turning it to the 100 mark on its dial, there is still enough resistance in  $R29$  to keep  $T2S$  voltage from firing tubes 5 and 6 too soon.  $R29$  is to be adjusted when the heat control goes into service with a welding machine, so that full heat will be obtained with  $R30$  turned to its 100 mark. No matter how  $R30$  and  $R29$

\* This phase-shifting circuit uses variable resistance and fixed capacity. Other phase-shifting circuits may use any combination of resistance, capacity or inductance, any one of which can be varied to produce phase shift. Another phase-shifting combination is described in Sec. 26-10.

In the synchronous-timing circuit of Fig. 15E, described in Sec. 18-3, the phase of  $T9P$  is changed by varying  $R50$ . No other network is needed, for when  $R50$  is shorted the current in  $T9P$  is lagging nearly 90 degrees behind the supply voltage. However, as  $R50$  is inserted, the current through  $T9P$  is passing through so much resistance that the current is closer in phase with the supply voltage and advances the peak of  $T9S$  by a corresponding amount.

are adjusted, the voltage between points 13 and 7 is always the same as the voltage between 7 and 8, which is 230 volts. *R28* is adjusted to give the proper voltage across *T2P*, and should not be changed.

**19-8. The Resonance Filter.**—In Fig. 19*E*, only capacitor *C14* and reactor *X2* remain to be explained. These devices act as a filter which lets nothing but good 60-cycle current get through to energize *T2P*. Owing to its special design, this peaking transformer *T2* will give false operation if the voltage across its primary winding (9-to-7) changes or dips at any time other than when the 60-cycle line voltage normally crosses the 0-0 line. These unwanted voltages cannot pass through the combination of *C14* and *X2*. Neither *C14* nor *X2* by itself can pass enough a.c. to give *T2P* its required voltage, but the sizes of *C14* and *X2* are carefully selected\* so that one offsets the other only at exactly 60 cycles a.c. As a result, a good 60-cycle wave passes through this *C14-X2* combination like water through a sieve, but any other voltage surge or harmonic frequency is stopped like a handful of pebbles. The voltage across either *C14* or *X2* may be as high as 600 volts.

**19-9. Advantages of Heat Control with Ignitron Contactor.**—An Ignitron Contactor or Weld-O-Trol, by itself, probably does not produce better welds or less power disturbance than a magnetic contactor used with the same welder (as described in Sec. 14-8). However, adding a heat-control equipment to phase-shift these ignitrons also gives most of the advantages of complete synchronous timing. The advantages of the phase-shift control are:

1. Each weld is started at the same point of the a-c voltage wave, thereby preventing variable transient currents which give inconsistent welds and overheat the electrodes.

2. By preventing the higher transient currents produced by random starting, the heat control decreases the occasional excessive current inrushes which cause the most troublesome voltage dips.<sup>14-10</sup> Many heat controls are installed with the

\* By methods shown in the footnote of Sec. 14-6, inductive reactance is made equal to capacitive reactance at 60 cycles a.c. These equal reactances are said to produce resonance, so this series connection of capacitor and reactor is called a *resonance filter*. The use of a similar capacitor and reactor, but connected differently, is described in Sec. 16-8 for the filtering of a d-c supply.

main purpose of keeping the welder current within the limits that the power company can stand. Any user of large ignitron contactors will improve the voltage condition at his welders by adding heat control. Occasional transients can still occur, since this arrangement permits welds to start with the same polarity that ended the previous weld.

3. The original purpose intended by the use of heat control is to provide a way to change the heat at the weld by turning a knob instead of by changing taps on the welding transformer. With the heat-control knob, the weld heat can be adjusted while the welder is working. The heat does not change in noticeable steps, but can be changed very slightly when necessary.

4. Seam welders may use the heat-controlled ignitron contactor at high speeds that permit a continuous flow of a.c. without interruption. Welding current flows during a part of every half-cycle, while the control switch remains closed. By phase-shifting the ignitrons, welding current flows during only a portion of each half-cycle. The remaining part of each half-cycle, when no current flows, becomes the cool time between weld spots; 120 of these occur during each second (on 60 cycles a.c.)

5. Ignitron contactors with heat control are used to supply large continuous current loads (quite different from welders) where the amount of current must be easily and accurately adjusted. These loads may exceed the rating of a single ignitron contactor.<sup>5-13</sup>

**19-10. Proper Use of Heat Control.**—Although heat control prevents most of the transient currents of the average ignitron contactor, it cannot prevent the transient that sometimes comes from starting a weld with the polarity with which the previous weld ended. Either tube can start a weld.

Heat control by phase-shifting ignitron tubes should not completely replace use of taps on the welding transformer; at least one should know what difficulties may result from using ignitrons at low-heat settings. As shown below,<sup>10-12</sup> ignitron tubes are working just as hard when the heat control is set at 50 on its dial as when the heat-control slider is turned up to 100, assuming that no other change has been made in the welder setting.

Although the phase-shifting of ignitrons provides heat-control of the weld, the dial of the adjusting resistor (*R30*) is not marked to show heat in per cent. At 70 on the *R30* dial, the tubes are

passing about 70 per cent current. A pointer-stop ammeter that reads 1000 amp with the heat-control dial set at 100 reads about 700 amp when the dial is set at 70. The actual heat at the weld changes as the square of this current;<sup>14-2</sup> if the dial is set at 70, the weld heat is  $0.7 \times 0.7 = 0.49$ , or about one-half of the heat at 100.

No dial setting below 40 should be tried if the welder is operating at 230 volts, nor any setting below 20 with a 460-volt welder. Below these settings, there is not enough line voltage so late in each cycle to fire the ignitrons properly. However, these minimum settings still give adjustment down to 16 per cent heat at 230 volts, and 4 per cent heat at 460 volts.

In practice, it is better not to operate below 50 to 70 on the heat dial if transformer taps are available on the welding transformer. Rather than operate on a high transformer tap and only 50 on the heat dial, change to a lower transformer tap, so that the heat dial can be set between 70 and 100. This change decreases the load requirements of the ignitrons and decreases the disturbance or maximum instantaneous load drawn from the power feeder.

**19-11. Voltages in Phase-shifted Power-tube Circuit.**—Just as we described<sup>17-8</sup> the changes of voltage and current in an ignitron-tube circuit passing full waves of current, we must now see how the voltages across the ignitrons and across the welding transformer change while the circuit is phase-shifted at reduced-heat settings. Figure 19L shows these voltages, together with the current to the welder, when the heat control is adjusted for partial heat, or about 70 on the dial. Figure 19M shows similar curves for low heat, with the dial set at about 40. For the corresponding curves at full heat (100 on the dial), see Fig. 17C.

Operating at reduced heat, the ignitrons pass current during only part of each cycle. Only when the ignitrons are passing current is there any voltage across the welding transformer. Weld heat is produced during only the shaded portion of the lower curves. The solid lines of these curves are the pictures that are shown by an oscilloscope connected across the ignitrons or the welding transformer. The current wave is seen by connecting the scope across a current transformer and resistance, as shown in Fig. 6B.

The welder current and voltage during a 2-cycle weld are shown in Fig. 19N. First this weld is shown as made with full-wave current, not phase-shifted by heat control. The decrease in welder voltage during these 2 cycles is perhaps 5 to 8 per cent, indicated by the lower voltage peaks. Then another weld is shown using the same welding stock, but with the ignitrons phase-

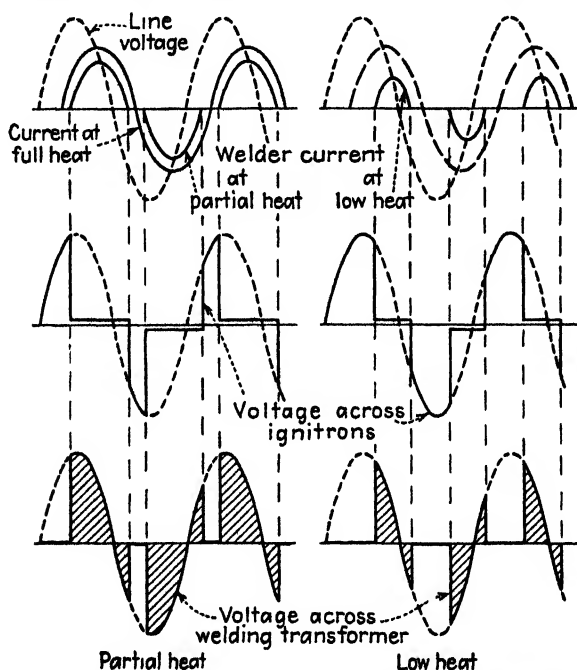

FIG. 19L.—Voltage and current curves at partial welder heat.

FIG. 19M.—Voltage and current curves at low welder heat.

shifted to about 60 on the dial. In order to get the same heat into the weld during this smaller portion of each cycle, the welding transformer is set on a higher tap. This results in greater current drawn from the line while the ignitrons pass current, and also causes greater voltage\* drop. It is sometimes difficult to detect this voltage drop in an oscillogram, since the reduced

\* This increased current or voltage drop is no larger than that which occurs when the welding transformer operates on its highest tap, at full (100 per cent) heat.

voltage exists during only a portion of each cycle, but there may be open-circuit voltage (no load) at the voltage peak.

As mentioned above, the best results and least line disturbance may result from using heat-controlled ignitrons together with welding-transformer taps, so that it is unnecessary to operate below 70 on the heat-control dial.

**19-12. Load Rating of Phase-shifted Ignitrons.**—The published ratings of ignitron tubes, as shown in Figs. 5C and 5D and discussed in Chap. 5, are always given for tubes carrying current during complete half-cycles, without being phase-shifted for

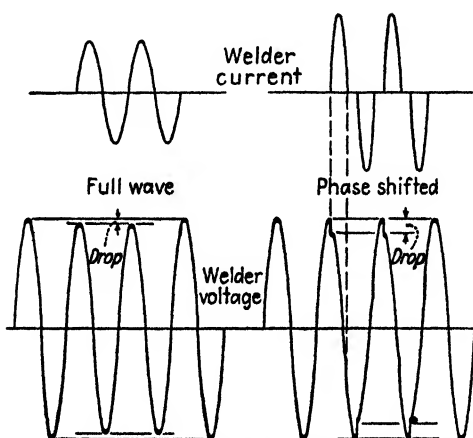

FIG. 19N.—Power demands of welds at full heat vs. phase-shifted welds.

reduced heat. It is neither correct nor safe to measure the load current of phase-shifted ignitrons with a pointer-stop ammeter and to use this current value in determining load or in selecting ignitron tubes. Instead, the heat dial must be turned to 100 during such a load test, so that the tubes pass current during complete cycles. This increased heat may burn the work, yet the current measured during this condition is the correct current value to use in selecting tubes or determining whether tubes are overloaded.

In the two welds shown in Fig. 19N, if a pointer-stop ammeter measures 1000 amp during the left-hand full-wave weld, it will also measure 1000 amp for the right-hand or phase-shifted condition. However, if 1000 amp is the published load rating of

these certain ignitrons, then they are carrying full load during the full-wave condition, but these tubes are seriously overloaded\* during the phase-shifted condition that produces the same weld heat.

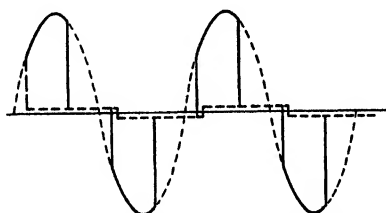

FIG. 190.—Load conditions of phase-shifted ignitron.

**19-13. Summary.**—To supplement welding-transformer taps for changing the weld heat, phase-shift heat controls are used to control the firing of ignitrons. These controls add a pair of thyratrons that can be adjusted to delay the firing of the ignitrons until a desired point on the voltage wave, thereby decreasing the portion of the cycle during which welding current flows. These thyratrons have duplicate grid circuits, which include a “hold-off” a-c bias and a “turn-on” peaking transformer. The phase angle at which this “turn-on” peak occurs is varied by changing the phase of the primary voltage of the peaker. This variation takes place in a resistor-capacitor bridge circuit, where a variable resistance adjusts the peaker-voltage position through a range of from 135 to 45 degrees behind the line voltage. The a-c supply to the peaker passes through a capacitor-reactor filter, tuned to line frequency, preventing surges or harmonic voltages from causing false peaker operation.

Adding this heat control to an ignitron contactor gives the welder most of the advantages of synchronous starting, eliminates most transients and decreases the disturbance on the power system. However, best results warrant using welding-transformer

\* In this phase-shifted condition, the ignitrons are not overloaded because of any increased heat in the tubes. Instead, the tubes are overworked because they must hold back the inverse line voltage during a larger portion of each cycle. In Fig. 190 the dotted heavy line shows the very low voltages across the ignitrons when passing full cycles of current, but the solid line shows the inverse voltage applied to phase-shifted ignitrons, which severely overworks the tubes.

taps, so that the heat control does not operate below 70 dial setting, which is about 70 per cent current and 49 per cent heat. The amperes load drawn by phase-shifted ignitrons cannot be used in selecting tubes, for all tube-rating curves are based on full-wave operation. This heat-control circuit is part of complete synchronous controls discussed in the chapters following.



## CHAPTER 20

### SYNCHRONOUS SPOT-WELDING TIMER INCLUDING HEAT CONTROL

To provide more accurate a-c welding, there are complete synchronous controls that include all the features described in Chaps. 15 to 18, with the addition of phase-shift heat control of the ignitron power tubes.

**20-1. Synchronous Spot-weld Timer with Heat Control (CR7503-A125).**—This complete synchronous control looks very much like the equipment shown in Figs. 15A, 15B and 15C. Including heat control, the enclosure is somewhat larger and can mount Size D ignitron tubes as well as smaller sizes. To give heat control, another pair of thyratrons is added, so that two FG-95 thyratrons are mounted in the upper part of the panel between the GE-83 rectifier and the FG-17 thyatron, and a pair of FG-95 firing tubes is located in the lower part also. Under the small cover on the front door, there are two adjustments. The length of weld is set by a dial selector and range switch,<sup>18-4</sup> while another pointer is turned to give heat control at the desired current value.<sup>19-2</sup> The three indicating lamps show (red) control power is on the panel, (amber) the proper cooling water is flowing, and (green) the 5-min warming period is finished.

The complete elementary diagram of this synchronous control appears in Fig. 20A. Only the central portion of this diagram gives new circuits, which will be discussed in detail later. Other portions warrant only the following outline.

The supply circuits at the top and bottom of Fig. 20A are discussed in Chap. 16, where a separate control supply switch is suggested.<sup>16-1</sup> There are descriptions of the flow switch *TFS*,<sup>16-3</sup> the 5-min time-delay relay *TR1*,<sup>16-4</sup> the rectifier tube 1 and its method of producing a d-c supply<sup>16-7</sup> with its *C1-X1* filter circuit.<sup>16-8</sup> The safety circuit using *CR2* contactor<sup>16-10</sup> and the voltage divider (*R1*, *R2*, *R3*, *R7*)<sup>16-11</sup> are also discussed. However, in Fig. 20A, notice that *T7* is a supply transformer (2 windings) instead of an autotransformer (1 winding). The

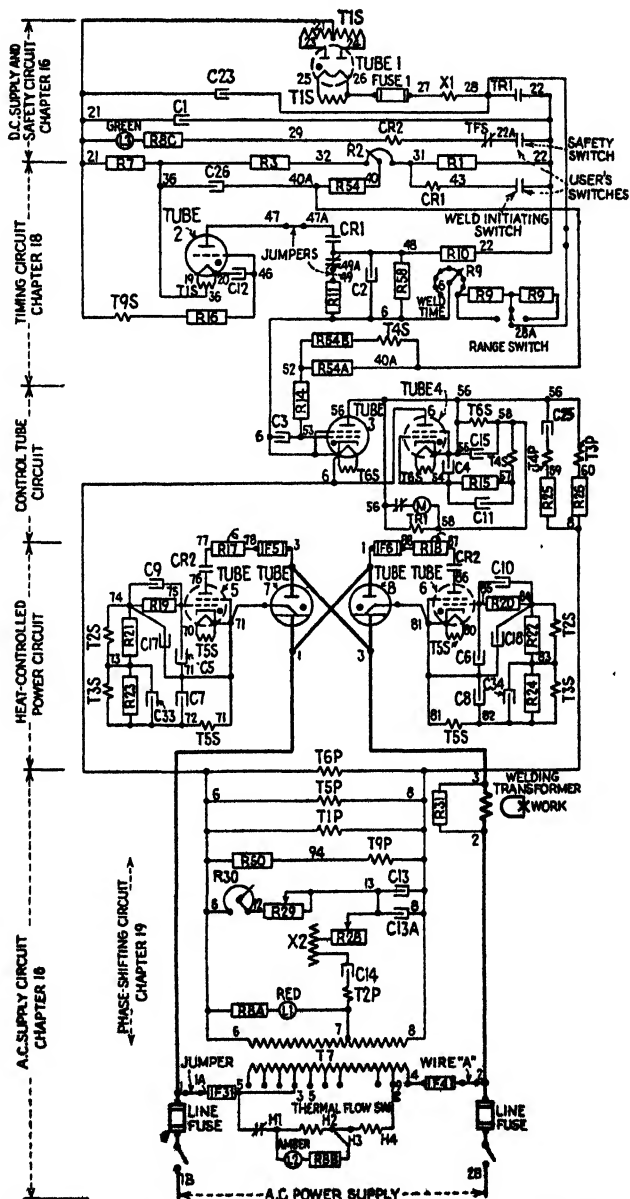

Fig. 20A.—Elementary diagram of synchronous timer with heat control (CR7503-A125).

secondary of *T7* supplies 460 volts between point 6 and point 8, so the three transformers *T1*, *T5* and *T6* all operate from 460 volts. *T1* furnishes voltages to tubes 1 and 2; *T5* supplies tubes 5 and 6; and *T6* supplies tubes 3 and 4.

The timing circuit in Fig. 20A is the same as shown in Fig. 18A, except that tube 2 now controls the starting of tube 3 instead of tube 5. As described in Chap. 18, the weld cannot start until the relay *CR1* closes its contacts. The grid circuit<sup>18-2</sup> of tube 2 then lets current flow through tube 2, which lowers the voltage at *C2* so that the cathode of tube 3 becomes more negative than the grid, letting tube 3 pass current. The length of weld is timed<sup>18-4</sup> by the rate at which *C2* is charged by current flowing through *R9*. The voltage increasing across *C2* finally forces the cathode of tube 3 to become so positive that the grid of tube 3 regains control and ends the weld by preventing tube 3 from starting additional cycles.

In the synchronous-control equipment previously studied, without heat control, tube 2 directly controls tube 5, which fires ignitron tube 7, starting the weld. Thyatron tubes 5 and 6 not only fire the ignitrons, but also operate as leading tube and trailing tube.<sup>17-1</sup> However, in this heat-control equipment, thyatron tubes 3 and 4 are added and act as leading tube and trailing tube, as shown below. This leaves thyatron tubes 5 and 6 with only the job of firing the ignitrons, which they must do at a certain point on the a-c wave as selected by the heat control.

In this heat-control equipment, the weld does not start at the instant when tubes 2 and 3 first pass current. It remains for tube 5 actually to start the weld by firing ignitron tube 7. Neither tube 2 nor 3 directly fires tube 5, but both make it possible for tube 5 to fire.

It is not necessary here that the peaking transformer *T9* start tube 2 at the right point on the voltage wave,<sup>18-2</sup> for this important and delicate job is now taken over by the heat-control circuit of tubes 5 and 6, as shown below. Actually *T9S* is purposely reversed here, so that tube 2 starts to pass current  $\frac{1}{2}$  cycle earlier, or during that half-cycle when neither tube 3 nor 5 can fire. This arrangement makes certain that tube 2 is already firing at the very start of the next half-cycle when tube 3 can fire.

**20-2. Leading-trailing Control Circuit.**—The portion of Fig. 20A close to tubes 3 and 4 is shown again in Fig. 20B, with these

same circuit parts rearranged so that they resemble more closely the similar circuit shown in Fig. 17B. Tubes 3 and 4 of Fig. 20B are controlled in the same way as tubes 5 and 6 are controlled in Fig. 17B, to give the leading-tube-trailing-tube action.<sup>17-4</sup> Briefly, this means that tube 3 is always the leading tube, since

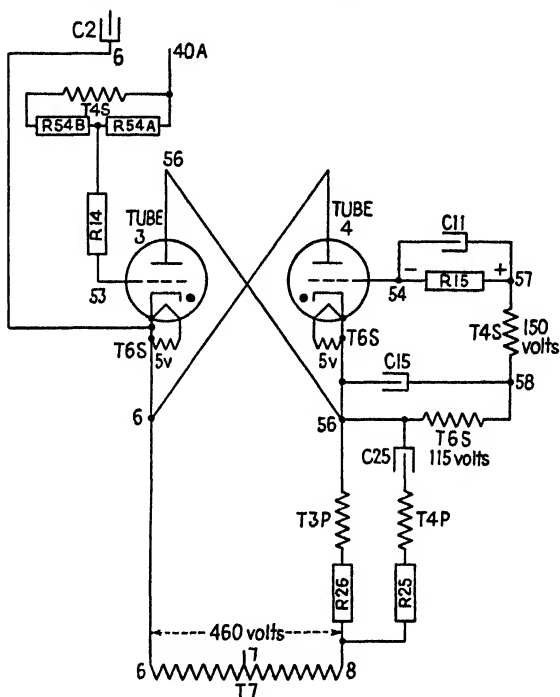

FIG. 20B.—Leading-trailing control circuit.

it must always pass current first, before tube 4 can pass current. Tube 3 alone receives the controlling signal from the d-c timing circuit above. When tube 3 passes current, it makes tube 4 pass current also, so tube 4 always trails, or is the trailing tube.

In Fig. 20B, tube 3 passes current when its cathode 6 is made more negative than grid 53,\* at the instant when tube 2 fires in

\* The grid circuit of tube 3 includes a 4-volt winding T4S. Only half of this small voltage appears across R54A. This 2-volt a-c "ripple" makes grid 53 more positive at the start of each half-cycle than at the end, and helps tube 3 to pass current at the beginning of the half-cycle or not at all. This same result is gained in Fig. 17B, where the low-voltage T5S winding is

the d-c timing circuit. To pass through tube 3, this current must start from the 8 end of supply transformer *T7* and pass through *T3P* or *T4P* to point 56, then through tube 3 and back to the 6 end of *T7*. Forget *T3P* for the moment, but notice that *T4P* is the "feedback" transformer, whose *T4S* winding is in the grid circuit of tube 4. After the tube-3 current has been passing through *T4P*, a voltage appears across *T4S* which makes tube 4 pass current for the half-cycle following. The circuit of this trailing tube 4 works like that described in Sec. 17-6, except that tube 4 does not fire any ignitron tube. Transformer *T4*, instead of being connected across the welding transformer, is itself part of the load fed by current through tube 3, which current is nearly in phase with the supply voltage. To make the voltage surge of *T4S* appear late enough in the cycle, at a time when there is enough supply voltage to force current through tube 4, it is necessary to use capacitor *C25*, which causes *T4P* voltage to lag considerably behind the supply voltage.

When tube 3 passes current, some of this current flows through *T3P*. When tube 4 passes the trailing half-cycle, this current also flows through *T3P*. Transformer 3 is the link that connects this control circuit to the phase-shifted power-tube circuit below. When tubes 3 and 4 pass current into *T3P*, then the *T3S* windings make it possible for tubes 5 and 6 to fire during these same half-cycles.

**20-3. Phase-shifted Power Circuit.**—Coming now to the power-tube circuit (tubes 5, 6, 7, 8) near the center of Fig. 20A, it is seen that the whole circuit to the left of tube 7 is the same as the circuit to the right of tube 8. For every device in the tube-8 or tube-6 circuit, there is a corresponding device in the tube-7 or tube-5 circuit. Tube 5 works in the same way as tube 6 works, and each tube works by itself. Since both halves of this power circuit work alike, only one half needs to be studied. Figure 20C shows the right half of this power circuit, including tubes 6 and 8. This is also like part of Fig. 19E, discussed in Sec. 19-5. Figure 20C shows thyatron tube 6 connected directly to ignitron tube 8, with the 3-amp fuse *F6* and resistor *R18* to prevent tube 6 from being punished if ignitron tube 8 fails to fire normally.

---

connected between point 70 and cathode 71 and adds this voltage "ripple" to help control tube 5.

The CR2 contact keeps both tubes from firing unless proper water flow and normal circuit conditions exist.

Looking now at the grid circuit of tube 6 in Fig. 20C, notice that there are three separate transformers whose windings T2S, T3S and T5S all have some effect on tube 6. This complete grid circuit starts at cathode 81, through T5S to 82, through R24 to 83, through R22 to 84, and through R20 to grid 85. T5S furnishes a "hold-off" voltage of 300 volts a.c. (see footnote to Sec. 19-5), which is negative at its 82 end at the same time that tube-6 anode is positive. Figure 20D shows this T5S voltage and the way that capacitor C10 forces the grid voltage to become

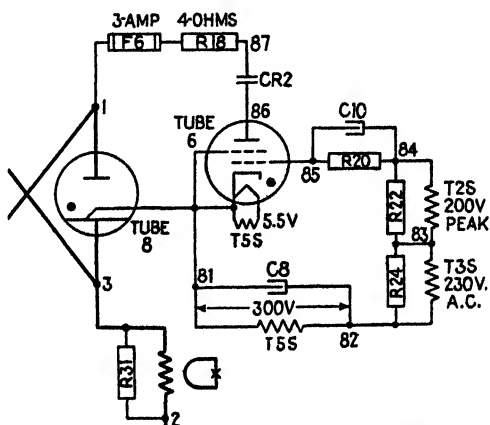

FIG. 20C.—Grid circuit of phase-shifting thyatron.

negative\* before the start of the half-cycle when tube 6 can fire. The peaked voltage produced by T2S is also shown.

Figure 20D is similar to Fig. 19F, but shows a higher curve of T5S voltage, which is purposely made so much larger (300 volts a.c. instead of only 80 volts) that the 200-volt "turn-on" peaks of T2S are still too far below the 0-0 line to be able to make the grid positive and fire tube 6. T5S is always too big for T2S alone, so T2S must get some help before it can ever fire tube 6. This help comes from T3S, which furnishes 230 volts a.c., but only during those cycles when its primary T3P receives current from tubes 3 and 4.

\*The purpose of C10 and R20 is described in Sec. 17-7, shown in Fig. 17D and later mentioned in Sec. 19-5. The effect of peaking-transformer T2 is also given in Sec. 19-5.

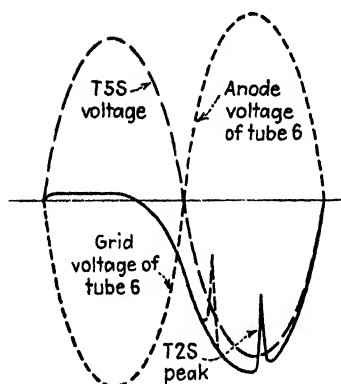

FIG. 20D.—Grid voltage, peak ineffective.

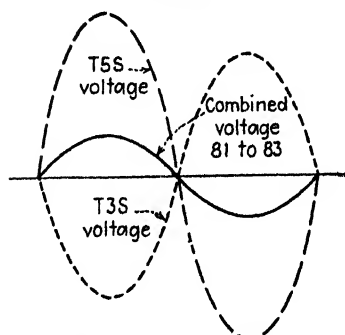

FIG. 20E.—Opposed voltages in grid circuit.

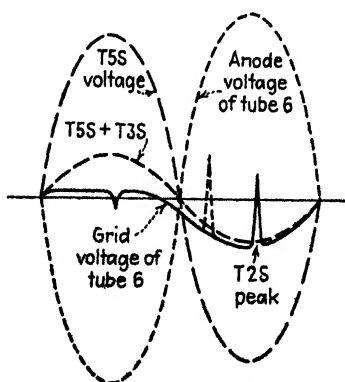

FIG. 20F.—Grid voltage, peak effective.

The voltages of *T5S* and *T3S* are shown in Fig. 20E. Notice that these voltages oppose or buck each other, that is, *T3S* is positive (above the 0-0 line) when *T5S* is negative (below 0-0 line). Therefore, when *T5S* furnishes 300 volts and *T3S* furnishes 230 volts, their combined voltage (from point 81 to point 83) is  $300 - 230 = 70$  volts, in phase<sup>14-3</sup> with *T5S*. This resulting 70-volt a-c wave is the solid line in Fig. 20E. Whenever tubes 3 and 4 are passing current into *T3P*, the voltage between points 81 and 83 decreases to this 70 volts, and the total voltage at grid 85 becomes like Fig. 20F, where it is seen that the 200-volt peaks of *T2S* are now able to reach above the 0-0 line. This makes grid 85 become positive wherever this *T2S* peak occurs, so *T2S* now makes tube 6 fire its ignitron 8 and pass welder current for the rest of that cycle.

Figure 20G shows how the grid circuit of tube 6 behaves while two different welds are being made. First a weld 2 cycles long is made at high heat, and this is followed 1 cycle later by another 2-cycle weld, this time at low heat. The upper curve shows when current flows in control tubes 3 and 4, while the bottom curve shows the welder current. Each half-wave of welder current starts just when the *T2S* peak reaches above the 0-0 line.

Although *T2S* is always producing these voltage peaks, they have no effect unless they are raised into position by the voltage of *T3S*. (When you are holding a comb in your hand, the teeth are always on the comb, but they do not comb any hair until you push them into the hair.) Tubes 2, 3 and 4 select those cycles during which welder current will flow, but tubes 5 and 6

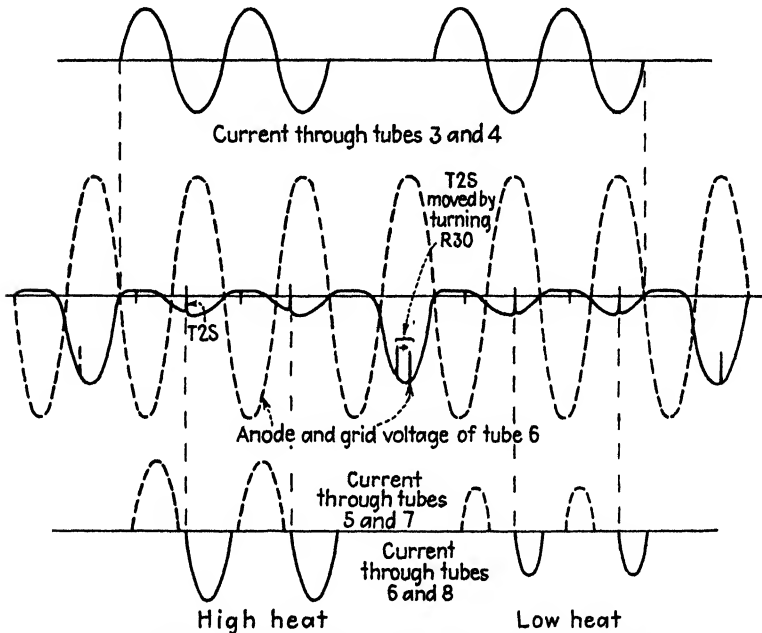

FIG. 20G.—Circuit behavior during heat-controlled welds.

say at what point the current shall start flowing during each of those cycles.

This tube-6 grid circuit, with its 300-volt “hold-off” voltage and two “turn-on” voltages of 230 volts and 200 volts peak, is like the problem of climbing out of a 30-ft pit, using a 20-ft ladder. You can always climb up 20 ft on the ladder, but that does not get you out. However, assume there is in the pit a platform 23 ft high, on which you can place the 20-ft ladder. No matter how wide the platform (*T3S*) is, you can climb out only at the spot where the ladder (*T2S*) extends above the edge of the pit (*T5S*). The voltage of *T3S* raises the tube grid voltage



into range, but it is the  $T2S$  peak that actually fires tube 5 or tube 6.

This  $T2S$  ladder is moved, to give the desired heat control, by turning the slider of  $R30$  in the phase-shifting control circuit in the lower portion of Fig. 20A. Shifting the voltage of  $T2P$  by means of  $R30$ ,  $C13$  and the rest of this phase-shifting circuit has been discussed in Secs. 19-6 and 19-7. Resistor  $R31$ , connected closely across the welding transformer, is described in Sec. 4-4.

**20-4. Adding Heat Control to Synchronous Equipment.**—The control panel just described is a synchronous equipment that includes built-in heat control. The advantages of heat control can be added to the synchronous spot-weld timer described in Sec. 15-2 by using the separate heat-control equipment mentioned in Sec. 19-3, whose diagram is shown in Fig. 19E. In connecting these two controls together, tubes 5 and 6 on the synchronous timer are disconnected from ignitrons 7 and 8, but continue to operate as leading and trailing control tubes 3 and 4. The two thyratrons on the heat-control panel are now connected to fire the ignitrons, and have complete phase-shifting grid circuits, including  $T3$  transformer (not shown in Fig. 19E). Supply transformer  $T5P$  of the heat control is energized from points 6 and 8 of the synchronous panel. On these two separate controls, the total equipment and circuits work together the same as the complete equipment of Fig. 20A. Two 5-min timing relays are included, each one protecting the tubes on its own panel.

**20-5. Complete Heat-controlled Synchronous Equipment in Three Parts.**—While the complete equipment of Fig. 20A is all in one enclosure and needs less installation wiring, there are places where the available installation space requires that this control be furnished in three smaller units. This arrangement uses (1) a standard Ignitron Contactor or Weld-O-Trol, (2) a smaller synchronous timer mounting only the heated tubes, and (3) a phase-shift heat-control like that of Sec. 19-4. Obviously, a welder that is first controlled by an ignitron contactor can then have either heat control or synchronous timing added, until finally all three parts are combined to give the same results as the one larger single device.

**20-6. How a Transformer Works.**—Having seen how the peaked voltage wave of  $T2S$  is used<sup>20-2, 19-5</sup> for making tubes 5

and 6 fire at the desired point on the voltage wave, we must now learn how this  $T_2$  peaking transformer produces this unusual wave shape. First, see how an ordinary transformer works, whose input or primary voltage curve has the same shape as its output or secondary voltage curve.

In any transformer, there is no electrical wire-to-wire connection between the windings. The connecting link between windings is the magnetism or magnetic flux produced in the iron core upon which the windings are placed. The current entering the primary winding produces magnetic flux in the iron, which in turn causes current to be produced in the secondary winding. A normal transformer will stop producing its secondary voltage if the iron is somehow removed or made unable to change this magnetic flux. Furthermore, the output voltage of the transformer is not produced merely because there is magnetic flux in the iron; the voltage is produced by any *change* in the amount of flux. Suppose that a d-c voltage is connected to one winding of a transformer. The direct current flowing in that winding certainly produces magnetic flux in the transformer iron, yet there is no voltage produced from the other winding. The amount of flux is not changing. However, when this d-c circuit is closed or opened, the magnetic flux changes suddenly, producing a voltage kick from the other winding. This shows why a transformer works on a.c. but does not work on d.c.; a.c. is a rapidly changing current, which continuously changes the magnetic flux, and these flux changes produce the a-c voltage in the secondary winding.

Figure 20H shows the familiar a-c curve of voltage as applied to the transformer. In most transformers the resulting current lags 90 degrees behind the voltage (because the transformer is mostly inductance). The magnetic flux is right in step with this magnetizing current, so Fig. 20H shows current and flux curves both 90 degrees behind the voltage. As shown above, the flux does not produce secondary voltage, but the *change* of flux does. When flux is greatest (at top of its curve), it is neither rising nor falling. Since it is not changing, it produces no secondary voltage, so secondary voltage is zero at that moment. However,  $\frac{1}{4}$  cycle later, when flux is zero and is crossing the 0-0 line, the flux is changing so rapidly that it produces the greatest secondary voltage. In this way, the curve of secondary voltage lags 90

degrees behind the flux curve, and in this case the secondary voltage is 180 degrees behind or exactly opposite to the primary voltage. So much for a standard transformer.

However, the peaking transformer used in heat-control circuits described so far is called a *resistance peaker*, for it has large

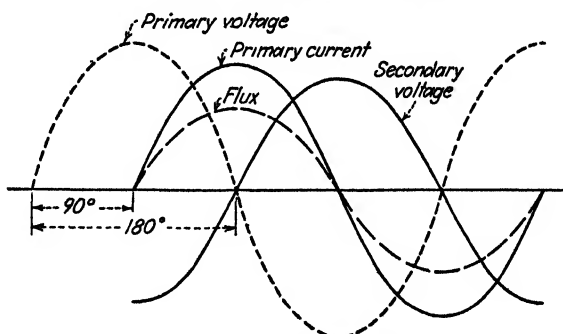

FIG. 20H.—Transformer voltages, current and flux.

resistance built in series with its primary windings. Whatever current flows in this primary, to magnetize the iron, must flow through the resistance also. As a result, this magnetizing current is nearly in phase with the primary or supply voltage, so the

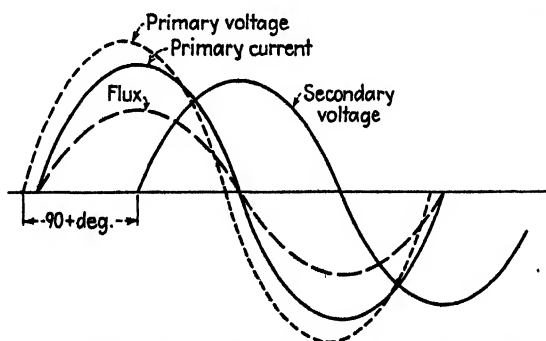

FIG. 20I.—Transformer curves, resistance limited.

magnetic flux curve is also nearly in phase, as shown in Fig. 20I. Next, since the largest secondary voltage appears when the flux is changing most rapidly, a smooth secondary voltage curve is drawn, slightly more than 90 degrees behind the primary voltage curve. Now, what about the voltage peaks that *T2S* produces?

**20-7. The Peaking Transformer.**—Whenever a transformer is built with the usual amount of iron in its core, a smooth a-c curve of secondary voltage like Fig. 20I usually results, since the flux can change as shown by curve 1 of Fig. 20J. However, if the amount of transformer iron is purposely decreased in the section around which the secondary is wound, then this smaller amount of iron cannot hold the usual amount of magnetic flux. When the primary current increases, the flux increases in this iron up to the limit where the flux cannot increase further. (This is quite like a 3-year-old child at a banquet table. A small stomach limits the amount he can eat, so if he starts at the same rate as the

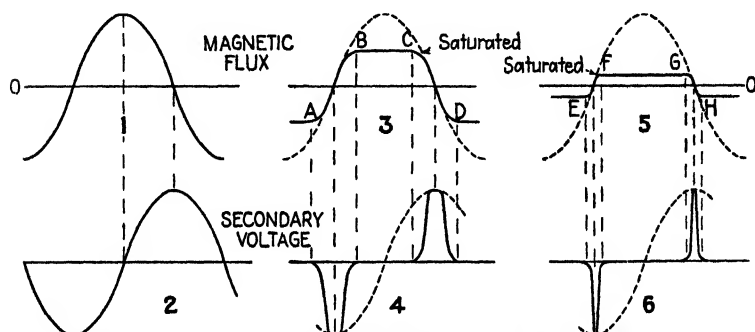

FIG. 20J.—Producing the peaked wave of the peaking transformer.

grown-ups he will soon reach his limit and stop eating.) The iron becomes “saturated,” so the amount of flux must stop changing, as in the flat part of curve 3 of Fig. 20J. The flux is changing normally between A and B. However, there is not enough iron to let the flux increase higher than B, so the flux does not change further until it is time to decrease at C. The flux changes direction normally between C and D, but cannot change beyond D. As curve 2 shows the secondary voltage produced by the gradual flux changes of curve 1, so curve 4 shows the secondary voltage produced by the flattened flux curve of 3. Between C and D, where the flux is changing normally, the secondary voltage is as high as usual. Between B and C, where the flux is not changing, there can be no secondary voltage.

To make a peaking transformer with a steep narrow peak, the transformer iron is carefully designed so that it becomes saturated very soon after the magnetizing current changes direction, as

shown in curve 5. The magnetic flux remains constant so long ( $F$  to  $G$ ) that only a very small part of each cycle remains ( $E$  to  $F$ , and  $G$  to  $H$ ) for producing the secondary voltage peaks of curve 6. In this way, a saturated transformer produces a voltage peak at the instant when its flux is crossing the 0-0 line.

By fitting these voltage peaks into their proper places in Fig. 20I, the curves of Fig. 20K result. This resistance peaker produces its secondary voltage peaks near the beginning of each

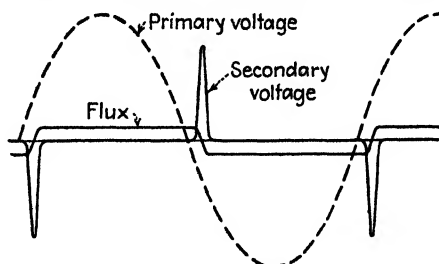

FIG. 20K.—Voltage curves of peaking transformer (single heat range).

cycle of primary voltage. These turn-on peaks of  $T2S$  are then delayed to the desired position by using the phase-shifting circuit of Fig. 19J, as already described.<sup>19-6</sup>

**20-8. Double-range Heat Adjustment.**—The above arrangement gives the entire range of heat with only one turn of the  $R30$

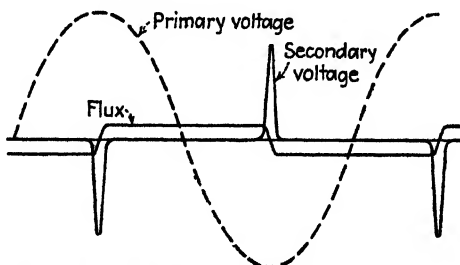

FIG. 20L.—Voltage curves of peaking transformer (double heat range).

heat dial. Another type of heat control has a double-range heat adjustment, using the circuit of Fig. 20M. In this circuit, transformer  $T2$  is a peaking transformer of the *reactance type*, whose magnetizing current and flux lag 90 degrees behind the primary voltage, according to Fig. 20H. The resulting secondary voltage peaks occur about 90 degrees after the beginning of

each cycle of primary voltage, as shown in Fig. 20L. These voltage peaks are then delayed to positions more than 90 degrees behind the line voltage curve by using a capacitor-resistor circuit as before. This is the situation in Fig. 20M, where switch *S3* is shown in the low-heat position and *R30*, *C13* and *T2P* are connected in the familiar way. With *R30* shorted out, the primary *T2P* is connected directly between points 7 and 6, or 180 degrees out of phase with the voltage of *T7*. This makes the *T2S* peak appear in the middle of each half-cycle, so that the ignitron tubes are fired at partial heat. As *R30* is inserted in circuit, *T2S* lags still more, and the weld heat is further reduced.

Notice that, when *R30* is shorted out, the position of switch *S3* makes no difference. When greater heat is desired than is possible with *S3* in the position shown, *S3* is then moved to the high-heat position, closing both upper contacts and opening contact 13-to-9. This places reactor *X2* in this phase-shifting circuit in place of *C13*. When *R30* is now inserted, *X2* becomes effective and advances the phase position of *T2P*, bringing the *T2S*

peaks closer to the beginning of the cycle, thereby increasing the weld heat. If all of *R30* is inserted, this may advance the *T2S* peaks ahead of the desired full-heat setting; therefore the shunt circuit of *R28* and *R29* is provided, to limit the total resistance between points 6 and 13. The reactor *X2* produces an effect opposite to that of the capacitor *C13* described in Sec. 19-7, for the voltage across *X2* is 90 degrees ahead of the circuit current. To show this condition, redraw the vector diagrams of Fig. 19K upside down.

**20-9. Other G.E. Heat-control Equipments.**—The CR7503-A104 (also A101 and A103) panel has the same circuit as Fig. 20A except that its timing circuit is as shown in Fig. 18D; this is discussed in Sec. 18-6. Indicating lamps are not included and the water-flow switch gives instantaneous protection<sup>2-12</sup> instead of being of the thermal type.<sup>2-12</sup>

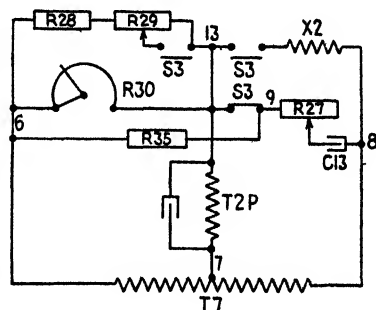

FIG. 20M.—Double-range phase-shifting circuit.

The CR7503-B11 panel also uses the timing circuit of Fig. 18D and the instantaneous water switch, omitting lamps. It also uses the double-range heat-control circuit of Fig. 20M described above.

The CR7503-A106 panel, whose special purpose is given in Sec. 25-4, uses the timing circuit of Fig. 18D and the double-range heat control of Fig. 20M. Its phase-shifting power-tube circuit is special.<sup>25-6</sup>

**20-10. Changing the Heat Control during the Weld.**—Most welders use the same heat-control dial setting for one weld after another, so the standard controls include only one heat-control dial, as already described. However, there are many welding operations that require high heat during part of a weld, followed by a period of low heat for annealing the same weld. Or, as in the case of multimatic welders using many sets of electrodes, the heat during each successive weld is individually controlled, since it is likely to be different from the heat required by the preceding weld. These changes in weld heat are obtained by using a number of heat-control dials, each of which is set for the heat desired during one certain weld period. All the heat-control dials control the same pair of firing thyratrons and power ignitrons, but only one dial is connected at any one instant. External change-over dial contacts are controlled by the welding machine, by hand-operated selector switches or by special sequence controls so that the weld heat changes as needed from moment to moment. In the heat-control circuit, such as Fig. 19J, this merely means that the amount of  $R30$  resistance is being changed quickly and automatically, by substituting other  $R30$  resistors into circuit, one after another, each of which may be set for a different amount of resistance, thereby shifting  $T2P$  and changing the heat at the weld. If a tapped resistor is used in place of  $R30$ , sets of contacts that switch the heat-control circuit from one tap to another will also give the desired changes in weld heat.

Often the problem is to keep the same weld heat from moment to moment, even though the welder secondary circuit is being changed by the effect of work metal inserted into the welder throat during only part of each welding operation. With more magnetic material in the welder-throat area, larger secondary voltage must be produced by the welding transformer or the weld heat decreases. This larger secondary voltage is obtained by

increasing the heat-control setting, either through manual- or limit-switch operation of heat-control dials by the welder or through use of an electron-tube *compensator*. Several forms of such compensators\* are being used, designed either to hold constant weld heat as the power factor of the welding load changes or to offset the effects of supply-voltage changes. In all cases, these compensators directly control the phase-shifting network (such as Fig. 19J). None of these advantages are possible unless the welder is controlled by ignitron tubes, with phase-shift heat control.

**20-11. The Weld Recorder.**—The welding industry is always seeking a device that will give an alarm or correction whenever the weld is not good or does not meet certain standards. Observing or testing the weld later is not fast enough. The perfect device must announce a bad weld as soon as it occurs. The closest approach to this perfect weld inspection is perhaps the Weld Recorder. As each weld is made, this recorder prints a mark which shows the amount of  $I^2T$  (current squared  $\times$  time) of the weld and closes an electric-alarm circuit whenever this  $I^2T$  is not within the limits chosen from operating experience. The recorder instrument pointer is moved across the paper roll while each weld is taking place, and prints its record after the weld is finished. This pointer moves at a speed in proportion to the square of the welder current. (A welder current of 2000 amp moves the pointer four times as fast as a welder current of 1000 amp.) At this speed, as long as the current flows, the total travel of the needle is an indication of current  $\times$  current  $\times$  time, or  $I^2T$ . Therefore, this instrument is also called the *ampere-squared-second recorder*. Remembering that weld heat<sup>14-2</sup> equals  $I^2RT$ , it is seen that this weld recorder responds to the actual heat in the weld as long as  $R$  (weld resistance) remains always the same.

Although this recorder cannot detect poor welds caused by changes in weld resistance, such as changes in weld stock, surface condition or mushroomed electrodes, yet it can immediately give an alarm when  $I^2T$  of the weld is considerably changed by a dip in line voltage, a change in weld time or an abnormal operation of the welder control, any one of which can generally

\* M. E. Bivens, Seam and Pulsation Welding Controls, *Electronics*, September, 1942.



cause a poor weld. It is not a compensator and makes no correction, but it gives record proof that  $I^2T$  is normal or it can be made to stop the welder each time when  $I^2T$  is abnormal. Its supervision is so close that it cannot be used to advantage without synchronous control of the welder. Although available separately, most weld recorders are combined with heat-controlled synchronous spot-weld timers, often in portable enclosures. Besides the pointer-moving circuit, the equipment\* includes a tapped current transformer and selector switch for choice of desired operating range, besides a number of sequencing relays.

**20-12. Sequence Controls Used with Synchronous Timers.**— Similar to the automatic weld timers discussed in Chaps. 9 to 12 are the sequence controls used with synchronous timers. Such sequence controls do not include a time-delay relay for controlling the length of the time of current flow, for this time is already accurately controlled by the timing circuit<sup>18-4</sup> of the synchronous timer. Of course, a weld timer having a weld-time or heat-time relay can still be used with a synchronous timer, but these time relays should be set for more cycles delay than the length of weld controlled by the synchronous timer. Figure 20N shows the elementary diagram of a sequence control for use with a synchronous timer; this can also provide a pulsation weld.<sup>10-1</sup> This diagram and Fig. 10B are similar, except that Fig. 20N does not include a *TD2* or heat-time relay. During a pulsation weld, the heat time is controlled by the synchronous timer and is repeated until the sequence control finishes the weld interval, which is the over-all length of the combined heat and cool times. Notice also that *CR2* is now a relay whose coil is shown under the main diagram and in series with resistors *R3*, so that this *CR2* coil can be energized from the voltage across the welding transformer (when heat control is not included). When the ignitrons pass current through the welding transformer, this also energizes *CR2*, so the amount of *R3* resistance left in circuit must depend on the supply voltage. However, if heat control is used, then the voltage across the welding transformer may be phase-shifted so much (like Fig. 19M) that it cannot operate *CR2*. With heat-control equipments, the *CR2* coil is energized along with *T3P* (and connected between points 56 and 8 in Fig. 20B) by the current through tubes 3

\* Rich, T. A., Ampere-squared Recorder, *Elec. Eng.*, August, 1941.

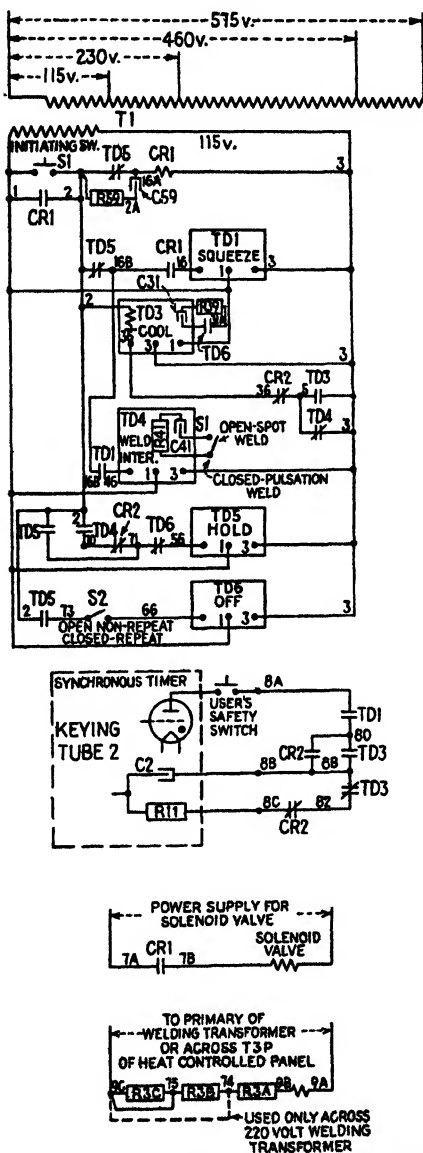

Fig. 20N.—Elementary diagram of sequence control (CR7503-F125).

and 4. This current is always a full sine wave (see upper curve in Fig. 20G) at any heat-control setting, and energizes *CR2* whenever tubes 3 and 4 let tubes 5 and 6 fire.

When this sequence control is used, the *CR1* relay of the synchronous timer is energized at all times by adding a jumper (connecting points 43 and 22 in Fig. 15E or Fig. 20A). The synchronous-timer circuit is then controlled directly by contacts of *TD1*, *TD3* and *CR2* on the sequence control, as shown in a separate group in Fig. 20N. This requires making three connections between the sequence control and the synchronous timer, at tube-2 anode, at timing capacitor *C2* and at its discharge resistor *R11*. Recent synchronous panels may provide terminals with jumpers for making these sequence-control connections (see 49-to-49A and 47-to-47A in Figs. 15E and 20A).

To follow the sequence in Fig. 20N, recall (from Sec. 9-11) that the foot switch has energized *CR1*, bringing the electrodes together. *TD3* has timed out immediately,<sup>10-6</sup> closing its contact 80-to-8B. When *TD1* finishes the squeeze time, the *TD1* contact (8A-to-80) completes the anode circuit to the keying tube 2, which starts the flow of welding current at the next proper point on the voltage wave. As shown above, this also energizes *CR2* on the sequence control. *CR2* normally-closed (n-c) contacts (36-to-5) reset *TD3* relay, but other *CR2* contacts prevent this from having any effect on the length of flow of welding current. When the synchronous timer brings this impulse of welding current to an end, *CR2* immediately drops out, stopping current flow through tube 2, discharging *C2* through *R11*, and starting *TD3* again for the cool time. When *TD3* again closes its contact 80-to-8B, it completes the anode circuit of tube 2, which synchronously starts another heat time or impulse of welding current. These current impulses and cool times continue until *TD4* finishes its preset weld interval. *TD4* n-c contact (5-to-3) then prevents the completion of another cool time, while its contact 2-to-70 closes its part of the circuit to start the *TD5* hold timer and carry through the remaining sequence already described in Sec. 9-11.

**20-13. Summary.**—This completes the explanation of the a-c synchronous spot-welding timer, including heat control by phase-shifting the ignitrons. Such control uses thyatron tubes 3 and 4 for leading-tube-trailing-tube action, in addition to

thyratrons 5 and 6 for firing the ignitrons at whatever point in the cycle is dictated by the phase-shifted grid circuits of tubes 5 and 6. This grid circuit, Fig. 20C, differs from that of tube 6 in Fig. 19E because a 300 volt a-c bias "holds off" tube 6 until this bias is overcome by the combination of 230 "turn-on" a-c volts of *T3S* and the 200-volt peak of *T2S*. *T3* is energized through tubes 3 and 4. The peaking transformer *T2* is a saturated-core unit, whose magnetizing current is resistance-limited, so its secondary peak occurs near the zero point of its primary voltage wave. Reactance-limited peakers are used in double-range heat-controls.

Multiple heat-control dials or tapped phase-shifting resistors give required heat changes during special annealing cycles, or from spot to spot, or to offset changes in welder secondary reactance. Electronic compensators directly control the phase-shifting circuit to give needed heat regulation. The Weld Recorder (responding to  $I^2T$ ) detects changes in line voltage, timing and control difficulties which can cause poor welds.

Our attention now turns to the initial starting and servicing of synchronous controls.

## CHAPTER 21

### STARTING AND MAINTAINING THE SYNCHRONOUS PANEL

The preceding chapters have shown how electron-tube equipment will control a spot or pulsation welder under normal conditions. The seam-welder controls (Chaps. 23 and 24) behave similarly. The study and knowledge of these tube circuits now make it possible to do a better job of placing such welder controls in service and of preventing the difficulties that can shut down the welder.

**21-1. Installing the Control.**—Before the control is received or unpacked, proper thought should be given to the proposed location of the welder, especially regarding the voltage problem described in Chap. 13. The control should be reasonably close to the welder, but may be overhead or in other nonproduction areas if necessary adjustments and an emergency stop switch are kept near the operator. A clean dry place is best, with good ventilation. Remember that good water supply is necessary, so freezing temperatures must be avoided. The control equipment should be located and mounted so that it is easily reached from both front and rear. A platform at the control is necessary, since servicing tube controls from a ladder is asking for trouble.

Most tubes are shipped by express, separate from the control cabinet. When the tubes arrive, they should immediately be checked for possible breakage, and should be operated electrically for a short time in place of other tubes already in service. They should then be safely stored until the control is connected to the electric power supply. Since most synchronous controls also include ignitron tubes to handle the large welder currents, review Secs. 4-1 to 4-7 at this time.

Unpack the control as soon as possible and look for any sign of rough handling or damage. Even though the control perhaps cannot yet be installed, use this chance to get to know its various parts. Mark various transformers, resistors, sockets and terminals with the numbers shown on the diagram. Before the

welder or main power cables are in place, it is possible to connect control power to the panel (following the steps given below) to see how many of the circuits work.

The cables bringing power to the welder and the control must be large enough (see Sec. 13-6 and Table V) and must be kept close together.<sup>13-7</sup> An air circuit breaker or a fused line switch is required in the circuit ahead of the welder. However, it is generally best to use a separate control-power switch so that the panel tubes remain warm even when the line switch is open. If it is known that more than 10 per cent voltage drop at the welder cannot be prevented, better control voltage can be obtained by running separate control wires back for connection closer to the main power transformer.

The proper size of line fuse will be equal to

$$\frac{\text{Amp. current during weld}}{60^*} \times \sqrt{\text{cycles per weld}} \times \sqrt{\text{welds per min}}$$

where amperes is read by a pointer-stop ammeter.

The instruction book furnished with the control probably outlines installation methods.

**21-2. Checking Equipment and Connections.**—While the electrical connections are being made from the control to the welder and other parts of the equipment, the bell ringer<sup>6-1</sup> is useful to check the complete circuits. Most troubles in starting tube control come from wrong connections between parts of the equipment.

No tube should be placed in any socket until the time recommended in Sec. 21-4. Ignitrons may be installed after the large cables are connected to the panel. Before any electricity is connected, the following things should be checked:

#### *Mechanical*

1. Carefully inspect the control panel for any wires or nuts that have become loose. All adjustable resistor bands should be tight. Check for possible broken connections to capacitors or resistors.

2. Untie anode caps so they swing freely. Free any relays tied during shipment. Work every relay by hand to be sure it

\* With 60-cycle a-c supply.

closes easily, and closes and opens its various contacts. Clean the sockets.

3. See that the 3-amp and larger fuses are in their proper places and that the fuse clips hold tightly.

4. On the door, see that the adjusting resistor handles move freely and are held in right positions. Do not force them beyond the limits. Operate range switches.

#### *Electrical.*

5. All control enclosures, machine frames, etc., must be solidly grounded, using grounding cables large enough so they will not burn off when a ground occurs.

6. Each wire or cable must be connected exactly as shown on the diagram supplied with the equipment. The welding transformer must be connected between line 2 and panel terminal 3, and never to terminal 1. Do not forget the control wire from line 2 to terminal 2 on panel (not required on heat-controlled equipments).

7. Be sure discharge resistor *R31* is connected close to welding transformer primary.<sup>4-11</sup>

8. Measure the a-c supply voltage that will be used for panel terminals 1A and 2A. Connect supply transformer *T7* for this voltage. (It is not satisfactory to connect *T7* for 440 volts if the measured voltage is 425 or 460 volts.) On panels without heat control, connect *T4P* for proper line voltage and see that *CR2* in the sequence control has its resistors shorted as needed.

9. If line voltage is 250 volts or less, short 3 ohms out of *R17* and *R18*, leaving only 1 ohm in circuit.

10. Ignitron tubes must be exactly vertical. Before connecting the starters, measure the resistance from igniter to cathode, using an ohmmeter, and keep a record of these values.

11. Check the panel timing circuit (points 21 or 22) for the presence of grounds, which must be removed.

**21-3. Starting the Tube Control for the First Time.**—The experience of placing many welder controls in service permits the writer to suggest several outlines to follow. Many of these points would not be necessary if one could safely assume the equipment to be connected correctly and the circuits to be in the same condition as when they were tested by the manufacturer.

It cannot be assumed that an oscilloscope and analyzer are always available, but a good voltmeter must be used.

This first outline applies directly to the CR7503-A124 control equipment in Chap. 15, Fig. 15E, which is a synchronous spot-welding timer, without heat control.

Remember that the ignitrons have voltage on their metal surfaces, whenever the line switch is closed.

A. Without any tubes except the ignitrons, and assuming that the equipment has been checked (as outlined in Sec. 21-2), it is time to apply control power for the first time. Leave the line switch open (if separate control switch<sup>15-2</sup> is used), and have the voltmeter connected across panel terminals 6 and 7.

1. Close the control switch and read the voltmeter, which should show close to 230 volts. If the voltage is correct, see that the time relay *TR1* is energized, with its motor turning. The red and amber indicating lamps should light, but the amber light goes out in about a minute, showing there is no water flow. The voltmeter should also read 460 volts between panel terminals 6 and 8.

2. Being sure that the welder electrodes are apart, close the line switch.\* The voltages between points should be checked as follows: From 1 to 6 = zero; 1 to 5 = line voltage; 2 to 5 = zero; 2 to 6 = line voltage; 6 to 8 = 460 volts. If different voltages are found, wires 1A and 2A are reversed or are connected to a different phase.

3. Being sure that the ignitron starters are connected to the starter posts, measure line voltage between 1 and starter post 56 of tube 8. Measure between 1 and point 58 (terminal in middle of rear of panel); the voltmeter should now read 115 volts more than line voltage. This shows that *T5S* is properly in phase with the voltage across tube 8. If this voltage 1-to-58 is less than the line voltage, open the switches and reverse control leads 1A and 2A.

If the line circuit is not completely installed, steps 2 and 3 can be delayed until *D* below.

B. Open the control switch and the line switch and place all the tubes in their sockets. Leave all top caps off the tube-anode connections, but place the grid caps on the side connections of the larger thyratrons. Close the control switch. If the voltage measured between panel terminals 6 and 7 is now below 220 volts, or above 240 volts, open the control switch and change the panel-7 lead at *T7* to bring this voltage close to 230 volts.

1. Notice that tube 1 shows its heated filament quickly, also a faint blue glow, which becomes much brighter when *TR1* closes its contact 5 min. later. The thyatron tubes (such as tubes 2, 5 and 6) show red-hot filaments after 30 sec. Then the mercury starts to deposit inside the glass,<sup>8-14</sup> giving the

\* If there is blue light in either ignitron, caused by current flowing, that tube may be gassy.<sup>4-13</sup>



tube a cloudy or dirty appearance, which disappears after some minutes. The anode caps are kept off the tubes to make sure they do not pass current for 15 min., during this first warm-up period. Notice that tube 6 has a very faint blue glow inside its shield cylinder, caused by grid current flowing in the closed grid circuit of tube 6. Tube 5 does not show this continuous blue glow.

2. When *TR1* has closed its contact after 5 min, turn on cooling water and close the safety switch at the welder. Within a minute the amber and green indicating lamps should both light, showing that the thermal-flow switch *TFS* has closed its contacts. At the same time, contactor *CR2* picks up on the panel. If the flow switch has not closed its contacts, be sure that at least  $1\frac{1}{2}$  gal of water per minute is flowing<sup>5-11</sup> (or 3 gal for size D tubes). With *TFS* contacts closed, operate the safety switch to be sure it controls *CR2*. Then turn the water off, watching to see that *TFS* contacts open in less than a minute.

C. When the tubes have been warming for at least 10 min, open the control switch, place the anode caps on the top of tubes 2, 5 and 6 and reclose control switch.

1. While waiting for *TR1* to finish timing, be sure the safety switch is open, set the welding transformer on a medium tap, close the line switch and bring the welder electrodes together. If there is current flowing at the electrodes, try to find out which ignitron is passing current. It is gassy<sup>4-19</sup> and should be replaced.

2. Open the line switch and close the safety switch. See that *CR2* is closed on the synchronous control (green light on). If possible, operate the welding machine by its starting switch. No welder current should flow, since the line switch is open. However, some contact on the welder or in the sequence control should now pick up *CR1* relay on the synchronous panel, or should directly close the anode circuit of tube 2. Tube 2 should pass current, with a faint blue glow, continuously until a little before the electrodes separate again. (Some sequence controls will not complete their operation while the line switch is open and no current flows to energize *CR2* of the sequence control.) If *CR1* is not being held closed by a jumper (between 43 and 22 in Fig. 15E, mentioned in Sec. 20-12), then *CR1* may be closed by hand to make tube 2 pass current. Set the time dial of *R9* at about 25 cycles, and look down into tube 5. Notice that, when tube 2 starts to pass current, a very faint blue glow appears in tube 5 for a short time. Turn the range switch of *R9* to the 1-to-10 position and notice that the same glow in tube 5 appears for a shorter time, when tube 2 fires. This shows that the d-c timing circuit is properly controlling the grid of tube 5.

D. An old set of electrodes may be used in the welder during these tests. Set the control for a 2-cycle weld, connect the welding transformer on a medium tap (not the lowest tap) and close the line switch. Turn on the water. No tubes should be passing current (with blue glow) except rectifier tube 1 and the very faint grid current in tube 6. If tube 6 passes anode current, showing a bright blue glow, the control leads 1A and 2A are reversed, or possibly *T4P* is connected from line 1 to line 2, instead of across the welding transformer.

1. Be sure the sequence control or pressure switch has been set so that the circuit will not close, to start the synchronous panel, until safe pressure is applied to the electrodes.

2. Using a piece of scrap stock, operate the welder. During this 2-cycle weld, every tube on the synchronous control should pass current. The blue glow in tubes 5 and 6 should be about equal and not too bright. Too bright light in tube 5 or 6 shows that its ignitron tube is not firing properly, and this may blow a fuse.<sup>4-10</sup>

3. If tube 5 fires, but tube 6 does not, then *T4P* may not be energized by the voltage across the welding transformer. Use the voltmeter across *T4P* when tube 5 fires, and correct the connections until tube 6 fires also.

4. The control should be adjusted for the welder with which it is working. As described in Sec. 16-2, the slider on *R50* should be moved (with all switches open) a little at a time, until it is seen that each weld is starting at the right point on the voltage wave, so as to cause the least current transient.<sup>14-7</sup> To do this, connect either a d-c millivolt meter or an oscilloscope<sup>6-7</sup> with one lead at terminal 1 of the synchronous control and with the other lead connected to line 1 at the line switch, or so as to include as much cable resistance as possible between the two leads of the instrument. The instrument then shows the very small voltage drop caused by welder current flowing through the resistance of this cable. (Or use the instrument with a current transformer and resistor as shown in Fig. 6*B*.) Now adjust *R50* until the oscilloscope shows that the positive half-cycles and the negative half-cycles during the weld are of equal height and do not change size. Or adjust *R50* until the d-c millivolt meter does not move above or below the zero mark when welding current flows.

Most controls are adjusted by the manufacturer so that the welding current starts at the right point for a welder of about 70 per cent power factor. If the control is then used with a welder of, say, 40 or 50 per cent power factor, without changing the factory adjustment of *R50*, the welds will still be all alike, but each weld will start with some transient current that may cause (a) unnecessary heating and mushrooming of electrodes, (b) larger current and voltage disturbance on the power line, (c) a slight change in the number of cycles from the correct length of weld shown by the *R9* time dial, and (d) possibly an extra half-cycle of current through the trailing tube an instant after the welding current has stopped.

(5) Using a cycle recorder<sup>6-8</sup> or oscilloscope, connect across the welder transformer and check the number of cycles of current flow for several marked settings of the *R9* time dial.

*E.* Adjust the time setting and welding-transformer tap to give the desired weld heat. Right now is the time to measure the ampere load required by the welder. See Sec. 4-25. Less than 40-amp load<sup>4-11</sup> may damage ignitrons as quickly as too much current. At the largest load, measure the voltage dip during the weld, using the oscilloscope. When you are satisfied that the tubes are firing normally and that the load is always above 40 amp, but within the load and percent duty shown in Figs. 5*C* and 5*D*, then the welder may go into service.

**21-4. Starting the Heat-controlled Equipment.**—The complete synchronous timer of Fig. 20A, including phase-shift heat control (CR7503-A125), is prepared for service in much the same way, checking all the points mentioned in Sec. 21-2. After these checks the outline below may be followed, similar to the procedure already given above.

**AA.** Leave the line switch open, and connect the voltmeter across panel terminals 6 and 7.

1. Close the control switch and read the voltmeter, which should show close to 230 volts. If the voltage is correct, see that time relay *TR1* is energized and that its motor is turning. The red and amber indicating lamps should light, but the amber lamp goes out in about a minute, showing there is no water flow.

2. Being sure that the welder electrodes are apart, close the line switch. If there is blue light in either ignitron, caused by current flowing, that tube may be gassy.<sup>4-10</sup>

The voltages between points should be: from 1 to 5 = zero; 1 to 4 = line voltage; 2 to 4 = zero; 2 to 5 = line voltage. If different voltages are found, wires 1A and 2 should be reversed, or connected to a different phase.

**BB.** Open the control switch and the line switch, and place all the tubes in their sockets. Leave all the top caps off the tube anode connections, but place the grid caps on the side connections of the larger thyatrons. Close the control switch. If the voltage measured between panel terminals 6 and 7 is now below 220 volts, or above 240 volts, open the control switch and change the panel-5 lead at *T7* to bring this voltage closer to 230 volts.

1. All the tubes on the front of the panel should show red-hot filaments after 30 sec. The anode caps are kept off the tubes to make sure they do not pass current for 15 min during this first warm-up. Tubes 4, 5 and 6 all have a very faint blue glow inside the shield cylinder.

2. When *TR1* has closed its contact after 5 min, turn on the cooling water and close the safety switch at the welder. Within about a minute the amber and green indicating lamps should both light, showing that the thermal flow switch *TFS* has closed its contacts. At the same time, contactor *CR2* picks up on the panel. If the flow switch does not operate, be sure that at least 1½ gal of water per minute is flowing<sup>6-11</sup> (or 3 gal for Size D tubes). With *TFS* contacts closed, operate the safety switch to be sure it controls *CR2*. Then turn the water off, watching to see that *TFS* contact opens in less than a minute.

**CC.** When the tubes have been warming for at least 10 min, open the control switch, place the anode caps on the top of tubes 2, 3 and 4, but not on tubes 5 and 6. Reclose control switch.

1. While waiting for *TR1* to finish timing, close the line switch and bring the welder electrodes together. If there is current at the electrodes, try to find which ignitron is passing current. It is gassy<sup>4-10</sup> and should be replaced.

2. Open the line switch and close the safety switch. See that *CR2* is closed on the synchronous panel (green light on). If possible, operate the

welding machine by its starting switch. No welder current should flow, since the line switch is open. However, some contact on the welder, or in the sequence control, should now pick up *CR1* on the synchronous panel, or should directly close the anode circuit of tube 2. Tube 2 should pass current with a faint blue glow until a short time before the electrodes separate again. If *CR1* is not being held closed by a jumper (between 43 and 22 in Fig. 15*E*, mentioned in Sec. 20-12) then *CR1* may be closed by hand to make tube 2 pass current. When tube 2 passes current, tubes 3 and 4 also pass current, showing considerable blue light, but only for the time for which *R9* is set. Tubes 3 and 4 can fire even though the line switch is open. Meanwhile tubes 5 and 6 have a very faint steady blue glow inside the shield cylinder, caused by grid current flow.

3. The voltages should be checked in the grid circuits of tubes 5 and 6. Close the line switch. If an oscilloscope is available, set it to show one cycle

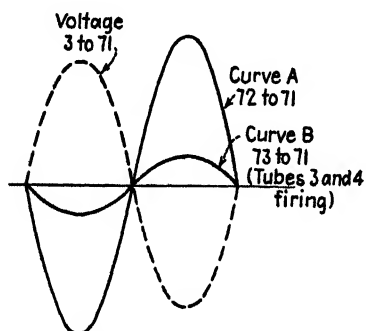

FIG. 21A.—Grid-circuit voltages of tubes 5 and 6 (Fig. 20A).

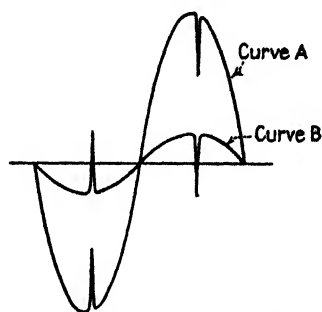

FIG. 21B.—Grid voltages of tubes 5 and 6, (A) before weld and (B) during weld.

on its screen, connecting its leads to 3 and 71; this gives the curve of anode voltage of tube 5. This is shown by the dotted curve in Fig. 21A. Take the lead off 3 and place it on 72; this gives the voltage across *T5S*, shown as curve A, which must be out of phase with the dotted curve. Moving this same lead to 73 gives the combined voltage of *T5S* and *T3S* (71-to-73). As long as tubes 3 and 4 are not passing current, this voltage is unchanged from curve A. However, when the circuit closes, firing tubes 2, 3 and 4, the curve on the oscilloscope changes to curve B, but only during those cycles when tubes 3 and 4 are passing current. Next, move the same lead from 73 to 74, to include the peaked voltage of *T2S* and to give curves shown in Fig. 21B. Curve B appears only while tubes 3 and 4 pass current, and curve A at other times. (These curves are different from Figs. 20D and 20F because the voltage across *R19* and *C9* is not included. The oscilloscope should not be connected to the grid terminal 75, since this may disturb the operation of tube 5.) Turn *R30* to move the position of the *T2S* peak. The grid circuit of tube 6 is similarly checked between points 1 and 81, 82 and 81, 83 and 81, 84 and 81.

A high-resistance voltmeter gives part of this circuit check. The a-c voltage between 1 and 82 is more than the voltage between 1 and 81. Voltage from 81 to 83 (or 81 to 84) is about 300 volts, but this drops to about 70 volts while tubes 3 and 4 are passing current. The peak voltage of *T2S* does not move the voltmeter needle, so its position cannot be checked with the voltmeter.

*DD.* An old set of electrodes may be used in the welder during these tests. Place the anode caps on tubes 5 and 6. Set the control for a 2-cycle weld and at about 60 on the heat dial. If the transformer has taps, connect to a medium tap. Close the control and line switches. Turn on the water. After *TR1* finishes its 5-min delay, no tube should be passing anode current except rectifier tube 1. (If tubes 5 and 6 are both firing, panel connections 1A and 2 are probably reversed.)

1. Be sure the sequence control or pressure switch has been set so that the circuit will not close, starting the synchronous panel, until safe pressure is applied to the electrodes.

2. Operate the welder on a piece of scrap stock. During this 2-cycle weld, every tube on the synchronous control should pass current. The blue glow in tubes 5 and 6 should be about equal and not too bright. Too bright light in tube 5 or 6 shows that its ignitron tube is not firing properly, and this may blow a fuse.<sup>4-10</sup>

3. On this heat-control panel, the slider on *R50* should not be moved. It is set at the factory so as to fire tube 2 early in the half-cycle just before tube 3 can fire.

4. Adjust the control for the welder with which it is working. Usually this adjustment should be made when the welder has its deepest throat setting and lowest resistance work (or shorted electrodes). An oscilloscope is most desirable for making this adjustment, as shown below. Temporarily this adjustment may be made by setting the *R30* dial at 100, then passing welding current for 1 or 2 cycles into scrap metal, or with shorted electrodes. If tube 5 fires, but tube 6 does not,\* then open the power switches and move

\* Tube 6 fails to fire because tube 5 starts to pass current too early in its cycle, and fires ahead of the power-factor angle of the welding transformer. This is shown in Fig. 21C, in which the dotted line shows the position that the curve of welder current normally takes, crossing the 0-0 line at *A* and *B*. The "turn-on" peak voltages of *T2S* occur too soon, at *D* and *E*. Tube 5 fires at *D* so much earlier than *A* that a transient current flows through tube 5, as shown by curve *DCF*. As long as this current is flowing through tube 5, there is not enough anode voltage to make tube 6 pass current. Tube 5 passes current until *F*; therefore tube 6 cannot fire at *E* even though the turn-on peak makes the grid of tube 6 positive for an instant. By the time the tube-5 current becomes zero at *F*, the turn-on peak has already passed by. Tube 6 "misses the boat" and cannot fire as long as tube 5 continues to fire ahead of normal point *A*. However, if *R29* is adjusted so as to delay the position of the *T2S* peaks until they occur at or slightly later than the power-factor angle of the welder, at *A*, then Fig. 21D shows that the current to tube 5 is normal and decreases to zero at *B*, just when the next *T2S* peak

the slider on  $R29$  (on Fig. 20A or 19E) so as to place a larger amount of  $R29$  resistance into circuit. (Be careful to move the right slider and not disturb the factory settings of other resistors.)

When tubes 5 and 6 both fire, there may be too much of  $R29$  resistance in circuit, so that the full heat of the welder is not being obtained, even when

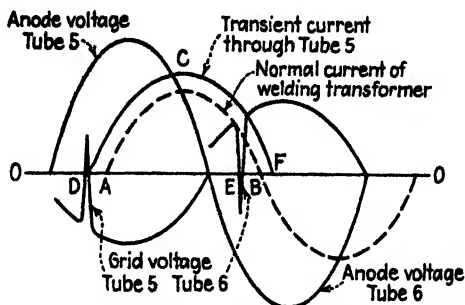

FIG. 21C.—Heat control is advanced too far, firing only one tube

$R30$  is set at 100. It is best to leave  $R29$  set at a value that lets tubes 5 and 6 both fire, but tube 6 does not fire at a setting of  $R29$  slightly beyond that value.

This setting of  $R29$  is easily made by connecting an oscilloscope across the welding transformer. The shape of the wave at full heat (with  $R30$  set at 100) should look like *c* of Fig. 17C, in which the vertical line  $JK$  should be

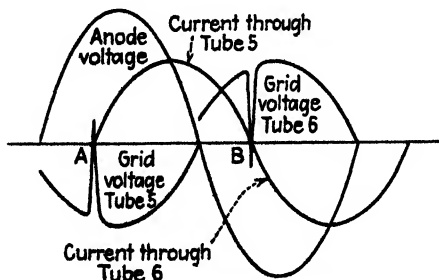

FIG. 21D.—Heat control is properly adjusted, firing both tubes.

only a thin sliver. There should not be a gap in the wave as seen in Fig. 19L.

*EE.* Adjust the time setting and the heat-dial setting to give the desired weld heat. If there are taps on the welding transformer, reduce the heat to the desired value by changing taps, so that the dial of the heat control ( $R30$ )

makes tube-6 grid positive. Tube 6 fires in its turn. Figure 21D shows how tubes 5 and 6 pass current when  $R29$  is properly adjusted and  $R30$  is turned to 100 on its dial.

can be set between 75 and 95 for final use. The advantages of this step are explained in Sec. 19-10.

Right now is the time to measure the amperes load required by the welder. To tell whether the ignitrons are overloaded or not, the load current must be measured at full heat or close to 100 on the dial of *R30*. (See Sec. 19-12.)

With the welding transformer connected on its lowest tap, if it is still necessary to use the heat control set below 40 or 50, it is obvious that the welding transformer is too large for the work being done. At these lower heat-control settings, it is more difficult to obtain consistent tube operation. This is more noticeable with 230-volt equipment than at higher voltages. When low-heat settings are necessary, look also for current loads below the limit of 40 amp.<sup>4-11</sup> In such cases, the addition of load resistors may not remove the trouble. The best cure is a smaller welder transformer, or the use of an autotransformer added between the control equipment and the welder.

**21-5. Adding Heat Control to Ignitron Contactor.**—When the additional heat-control panel is placed in service, as shown in Fig. 19*E*, the procedure is similar to parts of the preceding outline. Briefly, do not place thyratrons in their sockets until you are sure that close to 230 volts appears between points 6 and 7 or points 7 and 8. Do not place anode caps on tubes until they have warmed 15 min.

When anode caps are on the thyratrons and the line switch is closed, welding current should flow when the starting contact closes. If turning *R30* is not able to reduce the heat, leads 1*A* and 2*A* should be reversed. *R29* should be adjusted the same as in 4 of *DD* above.

**21-6. Maintaining Tube Controls.**—Over a period of years, tube controls work well only as they receive proper maintenance. Controls of this kind will not receive proper care from anyone who does not understand the tubes and circuits used. Therefore study of the preceding chapters is an important part of learning to take care of tube controls. This also applies to trouble shooting, in the next chapter, for a well-trained man can locate in 5 min trouble that the less trained man may try to find for days.

Experience shows that most of the control shutdowns can be prevented by proper checking, overhauling and replacement of parts. A complete maintenance program includes these inspections, together with stocking necessary parts, keeping complete records and preventing interference by unauthorized persons.

**21-7. Spare Tubes and Parts.**—In general, at least one spare tube of each type should be kept in stock. Where dozens of controls are used, the number of spare tubes should approach

10 per cent of the total tubes in service. Where only one or two controls are used, the cost of spare ignitrons may seem high. However, when this cost is balanced against the loss of production due to delay in obtaining tube replacements, the recommended spares are usually justified.

Spare tubes should be tested when received, by operating them in the controls for several hours before placing them in stock. Spare tubes that are defective are worse than none at all. Records of spare tubes are kept along with control records.<sup>21-10</sup>

Spare parts for the control panel should be kept, especially for those devices which cannot be obtained quickly from near-by sources. Keep on hand one of each kind of control transformer in the equipment, also spare tube sockets, adjusting rheostats or potentiometers and the larger capacitors and resistors. The smaller capacitors and resistors can be obtained at radio stores, but a general assortment should be kept. Where more than five duplicate controls are in active use, a complete spare control is certainly justified. There is a design trend toward smaller control units with plug-in connections, so that a spare control can be substituted to keep the machine in production while trouble is being located in the original control.

**21-8. Inspections and Checks.**—It is natural that controls which must be used continually should have more frequent inspection than controls used only occasionally. It is recommended that the controls in heavy continuous service should have a complete overhaul every 6 or 9 months. Before any inspection, be sure all switches are open and that all larger capacitors have been discharged by shorting them.

Low-pressure dry air may be used to blow dust from the equipment, but high-pressure air may damage parts. Remove all tubes, inspect the sockets and clean corroded contacts with fine emery cloth. Replace damaged sockets.

After cleaning, check all connections for tightness; check and adjust relays for proper clean contact; and look for any signs of overheating. Clean and paint rusted parts. Closely inspect time- and heat-adjusting resistors. Be sure to warm the tubes for 15 min before returning the control to active service.

In addition to this complete inspection, the operation of the control should be checked at weekly or monthly intervals, usually without interrupting the operator. When starting controls, check the 5-min time-delay period. Use a clamp-on



current transformer, resistor and oscilloscope to check the current wave and proper starting of the ignitrons. These will show an improper control adjustment or a late-starting tube. With a cycle recorder, check the setting of the time-adjusting dials.

Check the amount of cooling water through the ignitrons. (This is where the open drain<sup>4-6</sup> is handy.) Inspect and clean the water strainer, which can easily become partly plugged. Many users who obtain longest tube life are those who have the best supply of clean cold water and use more than the amount specified.

**21-9. Locking the Controls.**—Most welder controls should be padlocked, both front and rear, to prevent tampering by unauthorized persons, both for their own safety and for proper operation of the equipment. Have all such locks open by the same key. Where the control settings are fixed for a given job, the control door on the front of the control may be locked also.

**21-10. Records.**—Tube records (mentioned in Sec. 4-22) should be kept for all tubes used in the plant, including spare tubes. Where serial numbers are not used by the tube manufacturer, mark tubes with your own numbers. These records help in keeping proper spare tubes on hand and in knowing which tubes have failed within their warranty period so that credit adjustment can be claimed. The greatest importance of these records is that they show when an unusual number of tubes is failing in one place. In this way they draw attention to overload or misuse of tubes.

Users of large numbers of welding controls agree that a record sheet or book should be kept with each control equipment. In this record is written a note of every shutdown and its cause, also all tube replacements, panel inspections and unusual things noticed about the equipment. This life history of each separate control equipment will repay the bother of keeping such records.

A complete file or collection of instruction books and diagrams of all welder controls should be kept where they can be used by the men maintaining the controls. Also keep complete installation diagrams, showing all auxiliary connected devices. Extra wiring diagrams may be attached to controls for quick reference.

The man in charge of maintaining electronic welder controls should have sufficient knowledge of tubes, circuits and welder operation so that he can take full responsibility for keeping the controls in service, keep complete records, recommend spare supplies and use and care for the instruments provided.

## CHAPTER 22

### LOCATING TROUBLE

After the welder control has been placed in successful service and its operation is normal, the time will come when some part stops working and a good weld is no longer obtained. The suggestions and examples in this chapter cover the most frequent causes of such troubles, which the electrical maintenance man should learn to recognize. Open fuses and water-switch or time-relay contacts are indicated by lamps or are easily checked.

**22-1. Probable Causes of Trouble.**—The failure to weld may be caused by (1) the welding machine, (2) the main welder control, (3) power, water, air or other supplies, (4) the welded material and its arrangement, (5) the shape of the electrodes and their material, and (6) adjustments made by the operator. However, since it is human nature to place most blame on the part that is least understood, the tube-operated control gets more than its proper share of criticism. Electrical maintenance men must not only understand the control and its troubles, but must also know the problems of the welder and the weld itself.

In the control equipment, tubes normally give trouble sooner or later, since the useful life of tubes is less than that of other parts of the equipment. Most industrial tubes have a 1-year warranty, but may fail any time within 5 years of operation. Other units which fail less frequently are the resistors, capacitors, control transformers, rectifiers, relay coils and tube sockets. More frequently the trouble in the control is due to loosened connections, dirty contacts or improper operating conditions.

**22-2. General Trouble Location.**—The best way to be able to locate trouble is to know in detail how the equipment performs while it is working normally. One must know which tubes fire before the weld, which fire during the weld and which show no glow at all. One must realize that the appearance of a good thyratron carrying normal load is different from that of a tube which is overloaded or has low emission. Most desirable of all,

after learning how the circuits work, it is wise to measure and make a record of the voltages between various numbered terminals and across the windings of coils, transformers or resistors. Be sure to record the type of meter used to take these readings. Many voltages must be measured by oscilloscope, and the wave shapes should also be drawn for record. Then, when trouble occurs, it is much easier to locate the faulty part or circuit by those readings which have changed.

It is usually time wasted to start measuring voltages or checking parts before you know which part of the circuit is at fault. When trouble occurs, first watch the equipment as it tries to operate, to see which tubes fire normally. See which firing tube fails to fire or looks unusual. For example, in the synchronous spot-welder control of Fig. 20A, thyatron tube 6 may not fire. Do not blame tube 6 or its circuit until it is seen that tube 4 is firing normally, for it is known that tube 4 must fire before tube 6 can fire. If tubes 1, 2, 3 and 5 seem normal, but tubes 4 and 6 do not fire, knowledge of the usual operation shows that the trouble will probably be found in the circuits controlling tube 4, and not around tube 6 or other tubes. Likewise, if rectifier tube 1 is the only one showing a blue glow, even when the starting contact closes, waste no time around any other tubes, except tube 2, for no other tube can be expected to fire until tube 2 shows its blue glow. Of course, tube 2 itself may be all right, and CR1 may not be closing its contact to tube-2 anode.

Many troubles are located or isolated by opening the line switch and then operating the control circuits alone. This is possible only when a separate control switch<sup>16-1</sup> has been installed.

When a separate sequence control is used with a synchronous spot-welding timer, and faulty timing occurs, operate the synchronous timer alone by hand\* to see whether the fault is in the synchronous timer or whether it is caused by the sequence control.

Do not overlook the possibility that some change may have been made in power or control-circuit connections by workmen of another shift or department, so that the control power is now out of phase with the welder power supply.

\* This is usually done by pushing closed the contacts of CR1 relay (Fig. 15E or Fig. 20A) or by pushing both TD1 and TD3 of the sequence control (Fig. 20N).

The ignitrons and their firing thyratrons cannot fire until the main line switch is closed. Other tubes can fire if only the control switch is closed. If they act normally with the line switch open, but are not normal when the line switch is closed, the trouble is not in tubes but in circuit connections, including possibly a grounded condition.

When the weld is poor or erratic and all the tubes appear to work normally, make sure that the ignitron tubes fire evenly, by connecting an oscilloscope across them to show that the picture wave is always the same for every spot weld or cycle. To be sure that the time length of spot is not changing, a cycle recorder<sup>6-6</sup> may be necessary. (A spot shorter than 4 or 5 cycles can usually be checked by oscilloscope.) Only when such checks have been made is it then safe to say that the control equipment is not at fault.

**22-3. Is a Tube at Fault?**—If a thyatron or rectifier feels cool or shows no filament heat, wiggle the tube in the socket. If no heat appears, put another tube in its place. If it is seen that the tube is not firing normally, find out whether the trouble is in the tube or whether it is in the circuits to the tube. This is easily shown by using a new tube or by interchanging tubes on the panel. If tube 4 (Fig. 20A) fails to fire, open the control switch and carefully take out tubes 3 and 4, keeping them upright. Put tube 4 into the 3 socket, and put tube 3 into the 4 socket; close the control switch and rewarm the tubes. Then, after closing the starting contact, if this same tube (now in 3 socket) still fails to fire, the tube itself is at fault. However, if this tube fires in 3 socket, and the other tube in 4 socket now fails to fire, the trouble is outside the tube, so the circuit connected to the 4 socket or position must be checked. Where two tubes of one kind are not used on the same control equipment, a tube may be borrowed from another equipment or obtained from stock. Of course, if the stock tube is not good, much time will be lost in checking circuits, since the trouble lies in the tube. To prevent such trouble, tubes in stock should be checked every 1 or 2 months, by operating them in the equipment for an hour or for a shift. (Warm such stock thyratrons for 15 min before using the equipment.)

Where one of the ignitron tubes may be at fault, too much time may be needed to interchange the tubes. The oscilloscope<sup>4-15</sup>

will quickly show an ignitron that is hard-starting<sup>4-16</sup> or failing to fire. Measuring igniter resistance\* immediately after the equipment has been working will give values lower than normal, but this is still a better guide than nothing. If it can be seen, by watching the tubes or by use of an oscilloscope, that one ignitron is not firing normally, put a good stock ignitron in its place.

When an ignitron is replaced, a new firing thyatron may also be needed. When a new firing thyatron alone is added, check its ignitron also.

Always be sure that all tubes are good before checking tube circuits in detail. (However, where there is a contact in the tube-anode circuit, as in tubes 2, 5 or 6 of Fig. 20A, check to see that voltage is present between anode and cathode of the tube.)

A tube may be faulty and still look normal and pass current. If no tube will fire in socket 4, there is no harm in trying new tubes 1, 2 and 3, since they all operate in the circuits ahead of tube 4.

**22-4. Checking the Circuit Connections to a Tube.**—When it seems clear that the trouble is in the circuits connected to a certain tube socket, measure the voltages in parts of those circuits to compare with previous measurements. If no voltage is found across the secondary winding of a transformer, check to see that there is voltage across other windings of that transformer before thinking that the transformer winding has failed. Remember that the secondary voltage of a peaking transformer (*T2S* or *T9S* in Fig. 20A) cannot be measured by a voltmeter. An oscilloscope will check it.

When a thyatron fires continually in a socket, and a different tube in that socket also fires steadily, the grid circuit is open or the grid-to-cathode<sup>9-13</sup> capacitor is shorted. If instruments are not available, then, with switches open, disconnect one end of this capacitor and try the equipment again temporarily.

Open the control and line switches and check for loose or open connections in the tube circuit, including socket contacts. An analyzer may be needed for checking the separate resistors or capacitors. (Sometimes one end of a resistor or capacitor must be disconnected before its true value can be measured.)

\* Greater accuracy results from using the average of two readings and reversing the ohmmeter leads between readings.

Where two tubes have duplicate circuits, like firing tubes in phase-shifting circuits (tubes 5 and 6 in Fig. 20A), if trouble affects only one tube, the grid circuit of that tube may be at fault. However, if both tubes are affected equally, look for trouble in the primary circuits of those transformers whose secondary windings are in the tube grid circuits..

**22-5. Using the Oscilloscope.**—The description and simple operation of the oscilloscope are given in Secs. 6-7 to 6-14. To use the oscilloscope effectively\* on the circuits of a synchronous control, the scope should be modified as outlined in Sec. 6-9. Even without such changes, the scope is fine for watching how well the ignitron tubes are firing or for observing a-c line voltage dips, counting short welds or studying the shape of a rapidly changing voltage. However, without changes, most scopes cannot be used to show reversed polarity of a-c waves, and cannot show steady d-c voltages. If connected directly across tube grid voltages, they may disturb the normal tube operation.

Perhaps the simplest and most valuable use of the scope on welder controls is in watching the firing of the ignitron tubes, as mentioned in Sec. 4-15. The two vertical-input leads of the scope are connected to the top and bottom of the ignitrons. (Be sure the scope and leads can be safely used at these line voltages.) When the line switch is closed, but the ignitrons are not passing current, the scope should be set to show 2 to 5 full waves of a-c voltage on the screen, as shown in Fig. 22A. As the ignitrons fire or pass current, the a-c waves disappear, except for the small voltage peaks when the tubes fire. In Fig. 22A, tubes *A* and *B* show normal firing peaks. The larger peak at *C* shows that a greater amount of voltage is being applied before the tube will start, so tube *C* is hard-starting<sup>4-16</sup> (see Fig. 4D). At *D*, the tube failed to fire during its half-cycle, although tube *B* still fired normally.

If the ignitrons are controlled by a phase-shifting (heat-control) circuit, the curves of Fig. 22A may not apply, except at 100 per cent heat. At lower heat-dial settings, the voltage across the ignitrons is normally like the middle curves of Figs. 19L and 19M. Therefore, a hard-starting ignitron is more easily shown when the heat dial is at 100 per cent.

\* Weller, Servicing Resistance Welding Controls, *Electronics*, January, 1943.

When the ignitrons are fired by thyratrons, as in most synchronous or heat-controlled panels, the scope leads may be connected across a 4-ohm resistor in the thyatron anode circuit (such as across  $R17$  in Fig. 20A to observe the firing of ignitron tube 7). The normal voltage peak should now be narrow at any setting of the heat-control dial

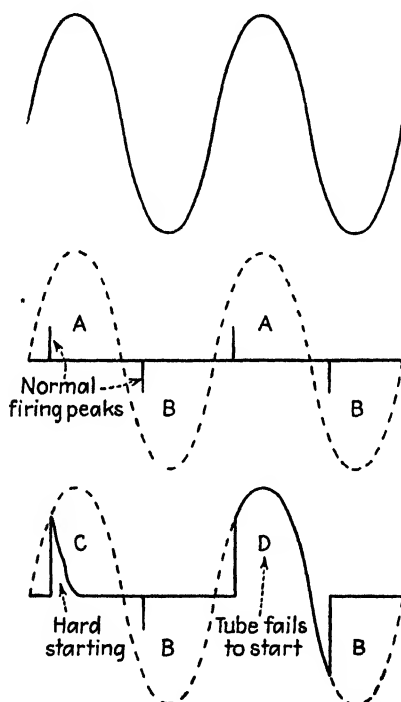

FIG. 22A.—Firing of ignitrons, shown by oscilloscope.

If a firing thyatron (such as tube 5 in Fig. 15E or Fig. 20A) seems to flicker off and on during the weld, connect the scope across the tube (anode to cathode) to see if the tube is receiving continuous voltage supply. A faulty fuse has been known to cause such flicker. In this case, a voltmeter or tester indicated that the fuse was good, but the scope quickly showed occasional missing half-cycles.

If the scope shows that the thyatron anode voltage is steady, but the thyatron fails to fire normally, it becomes necessary to connect the scope to the grid circuit. In any tube grid circuit,

the ground terminal of the scope must always be connected to the tube cathode (or cathode end of the voltage measured). Most grid circuits contain voltages from several transformers or rectifiers, and some of these voltages are seen only during the weld time. Figures 20*D* and 20*F* show voltage waves, seen by a scope in such circuits. Usually the ungrounded scope terminal is connected back of the grid resistor,\* such as point 84 in Fig. 20*A* or 20*C*. Connected from 84 to 81, the scope image shows the voltage peak of *T2S*, the hold-off a-c wave of *T5S* and the decrease of this a-c wave when *T3S* is also energized during the weld. As *R30* is turned to change the heat of the weld, the position of *T2S* peak is seen to move.

Similarly, Figs. 23*E* and 23*F* show grid-circuit voltages, including a d-c hold-off bias, which cannot be shown by most scopes without the changes of Sec. 6-9. Figures 25*E* and 25*F* can also be shown by a changed scope.

When a synchronous control fails to stop its current flow after the proper weld time, a scope (or d-c voltmeter) may be connected across timing capacitor *C2* to show if it charges to its proper d-c voltage.

**22-6. Poor Voltage Conditions.**—Although a certain welding-control equipment has been working well for months, the voltage conditions may be gradually getting worse (owing to increased load on the welder or the addition of other loads in the plant) until the control is in trouble. The thyatron tube circuits may become erratic, and the tubes may pass an extra cycle of current right after the main weld is finished. If the weld is long (like a seam or pulsation weld), the reduced voltage during the weld may decrease the filament heat, damage the thyatrons and give erratic timing.

A power supply whose voltage changes more than 5 per cent between day and night, or from hour to hour, gives trouble in some synchronous controls.

Where the power supply is 220 volts, greater care is necessary to prevent reduced voltage at the ignitrons than when higher supply voltages are used.

**22-7. Grounds.**—Almost every electronic control gives trouble when its circuit becomes grounded at any point that is not pur-

\* The scope may usually be connected to the grid 85, if the tube is first removed from the socket.



posely grounded. Such grounds usually occur in the connections between the control and other devices, such as the connections to the starting switch. When such wires are pulled through conduit, the insulation may be skinned or broken, causing a connection to the grounded conduit. This ground may prevent starting the panel, or it may not cause trouble until some later time.

Whenever a welder control gives faulty operation that is not caused by bad tubes or defective parts, use a voltmeter to see if there is voltage between the control circuits and ground (a water pipe, building steel frame, etc.) If such voltage is found, where the diagram shows no connection to a grounded circuit, then the cause of this voltage to ground is probably the cause of the control trouble. In Fig. 20A the entire timing circuit (between points 21 and 22 or between points 6 and 8) is insulated from ground, so it should not be possible to measure a voltage between any part of this circuit and ground.

If the power feeder to the welder usually operates ungrounded, then the weld itself is affected if an occasional or partial ground occurs. Any accidental ground can be expected to give trouble, even when it occurs in a distant part of the plant, on a different feeder. An insulation tester is desirable for measuring the condition of circuits in the plant.

**22-8. The Welding Operation.**—While the general process of welding\* is not discussed here, the following comments may help locate trouble.

Whenever the heat in the weld changes from one minute to another, the control equipment can be at fault, but there is greater chance that the trouble is elsewhere. Since the weld heat =  $I^2RT$ , and the synchronous control can influence only the current  $I$  or the time  $T$ , it is necessary to see what controls or changes the weld resistance  $R$ . This resistance includes the resistance of the metal pieces being welded, the resistance of any dirt or film on the metal surface and also the contact resistance between the pieces. This contact resistance changes by a large amount when the pressure changes on the electrodes. More electrode pressure gives less contact resistance and less heat in the weld. Changes in pressure make the welds too hot or too cold. The pressure gage may always show the same pressure

\* Refer to "Welding Handbook," 1942 edition, American Welding Society.

applied, and yet the electrode pressure or contact resistance can change from the following causes.

As the weld is made and the metal pieces are squeezed together, the electrodes must move together a small distance. If the electrodes are held by moving parts that are too heavy, these parts cannot move together quickly enough to keep the same pressure on the work. If these parts move in cylinders or ways that become tight, worn, scored, or unlubricated, the proper movement of the electrode is prevented and poor welds result.

When large currents flow in the secondary circuit of the welder, they produce forces that try to separate the electrodes. These forces subtract from the total force available, so that there is less pressure at the electrodes when large currents are passed than when smaller currents are passed.

On air-operated machines, where leather packings are used in the pressure cylinders, the welding pressure changes if the leather is not oiled correctly. If the packing is made of chrome-tanned leather, use a light mineral oil; if it is made of vegetable-tanned leather, use neatsfoot oil.

For best results, material must be cleaned before welding to remove scale, oxide and grease. The extra resistance of this surface dirt causes increased heat and spitting at the electrodes. The effect of such dirt is greater when welding low-resistance materials (copper and aluminum alloys) than when welding stainless steel or mild steel. Cleaning may be done by pickling, wire brushing, etc.

If the pieces being welded do not touch before the electrodes squeeze them, much of the total pressure may be needed to overcome this warp or bow in the metal, so that there is less pressure between the pieces and greater contact resistance, producing a hotter weld.

When welding together pieces shaped as in Fig. 22B, see that the electrodes do not touch far into the corner or radius, so that they have to press the bent parts into contact. Before the electrodes squeeze them, the pieces should already touch over the entire part being welded. The weld must be far enough from the edges of the pieces so that the melted metal cannot spurt from between them.

In order to keep the same heat in the weld, the electrodes must be held to the same size (from minute to minute) where they

touch the work. If electrodes  $\frac{3}{16}$  in. across wear down or mushroom until they are  $\frac{1}{4}$  in. across, their contact area has nearly doubled. The welding current can now pass through much larger parts of the welded pieces, so it loses its power to heat any part properly. Electrodes should be water-cooled (to within  $\frac{1}{4}$  in. of their tips), and should be inspected often to make certain that they keep their proper shape and size. Keep a stock of electrodes on hand and exchange them frequently instead of filing electrodes on the job.

Most electrodes are made of materials harder than copper, which give longer life. However, these very hard materials are not so well suited for welding low-carbon steels, for they have less conductivity, or cause greater heat in the electrodes, and

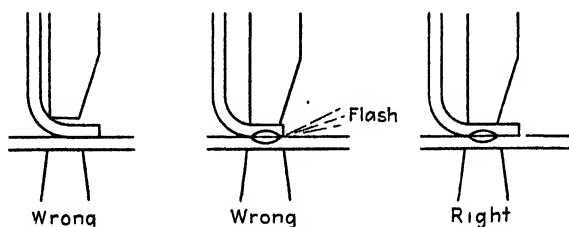

FIG. 22B.—Location of welder electrodes on work.

prevent the flow of larger welding currents. These harder electrodes are better suited to welding stainless steels, copper, etc., and to projection welding.

Where two welds must be made close together, the first weld needs much less welding current than the second weld. In making the second weld, much of the current passes through the first weld spot and does not help to produce heat in the second weld spot.

The heat in the weld decreases when a larger amount of steel material is placed inside the welder throat. Such changes cannot be prevented, except by correcting the heat with a compensator, applied to a phase-shifting control.<sup>20-10</sup>

**22-9. Examples of Troubles and Correction.**—Every plant should keep a record of all troubles on welders and control equipments, so that such experiences can help to correct later troubles. To serve as examples, a number of such experiences are described here, showing how such information can be used. The following examples may be familiar in many plants.

1. A small spot welder, using ignitron tubes for control, does not give enough heat to weld on transformer taps 1 or 2. On tap 3 there is so much heat that the welder burns holes through the work. Even on tap 3, the ignitron tubes do not show the blue glow that is often seen at their glass anode seals.

It is found that the welder is using so little current on taps 1 or 2 that the ignitrons refuse to pass anode current. What current reaches the welder must pass through the tube igniters, whose resistance prevents full voltage from reaching the welder. This operation, if continued, damages the tubes. However, on tap 3 the welder draws enough current to fire the ignitrons. The resistance of this circuit is much less, so the welder receives nearly full line voltage and now gives too much heat. The current is still too small to cause enough blue glow in the tubes so that it can be easily seen. A dummy-load resistor<sup>4-11</sup> is added so that, even on taps 1 and 2, the total current is now large enough to fire the ignitrons properly.

2. A spot welder in a new plant has worked well for a month. Without any change in the weld requirements, the synchronous timer becomes erratic and gives frequent bad welds. Several of the thyratrons on the panel occasionally flare up, but do not blow fuses. They are replaced by new tubes, but this does not correct the trouble.

Quick inspection of the panel shows no loose connections, but the tubes are not acting normally. A voltmeter is then connected across the control-voltage supply, showing 450 volts. However, the supply transformer (such as *T7* on Fig. 20A or Fig. 15E) is found to be connected for 480 volts. This makes such low voltage on the panel circuits that the tubes do not have proper filament voltage, and they fire incorrectly. When the equipment was placed in service a month previously, the control voltage was 475 volts, and *T7* was connected correctly. However, as the plant load gradually increased, loading the power transformers and feeders, the voltage at the panel decreased until trouble resulted.

Changing the tap connection on *T7* stops the trouble. However, one thyatron fails a week later, possibly owing to the punishment of operating at low filament voltage.

3. A new job is placed in a spot welder. The equipment works well for a few spots, but, when the welding transformer is connected to a higher tap to give enough heat at the weld, there is a flash as the electrodes separate and the work is burned. The hold time is increased so the electrodes are together longer. This prevents the flash, but it is noticed that one of the firing thyratrons on the synchronous timing panel lights again just after the weld is finished.

Several things can be done to cure this trouble, which may occur because the new job is heavier than previous work done by this welder. The increased current causes greater voltage drop at the welder. As the weld ends, the voltage rises again suddenly, disturbing the firing-tube grid circuit so that it fires the ignitron again. One remedy is to install larger cable to the welder to decrease the voltage drop during weld. The control voltage connections for the synchronous control can be moved to a point on the welder feeder closer to the power-supply transformer, so that the control

voltage is not reduced by the voltage drop of the welder feeder. In Fig. 20A or Fig. 15E, the 4- $\mu$  f capacitor *C26* is included in the timing circuit for the purpose of decreasing the disturbance caused by such voltage changes.

When this trouble occurs on synchronous spot-welder equipment without heat control (like Fig. 15E), try resetting the *R50* slider so that *T9S* fires tube 2 a little later in the cycle. A transient current in the welder transformer may be causing a voltage surge as the electrodes separate, enough to fire a thyatron. This surge may also be reduced by placing a lower resistance across the welding transformer primary. Between 8 and 200 ohms is suggested.

In extreme cases the welding transformer may have too little iron for the required load, and may even cause re-firing of the tubes several seconds after the welding current stops.

4. A synchronous spot-welder control (whose timing circuit is like Fig. 18D) gives erratic operation. It works perfectly for hours. Then it passes current continuously, with tubes 5 and 6 firing steadily. When a weld is tried, the electrodes and work are burned.

Tube 5 normally fires tube 6, so tube 6 is probably not at fault. Since tube 5 can fire if it loses its grid voltage, the grid circuit of tube 5 is suspected. (If an oscilloscope is available, it is connected<sup>22-5</sup> from the cathode of tube 5 to a point behind the grid resistor. This occasionally shows no voltage.) The slider of *R8* potentiometer is possibly making poor contact. It is found that, when the sliding brush contact of *R8* is pressed against the wire winding of the potentiometer, tubes 5 and 6 fire properly. The spring tension must be increased to press the contact brush firmly against this wire winding. Perhaps a new brush contact or a new potentiometer *R8* is the remedy.

5. On spot-welder control (as in Fig. 15E or Fig. 20A), tubes 2, 5 and 6 fail to fire. Relay *CR2* is open and the green light is out.

It is found that rectifier tube 1 shows no blue glow, but the  $\frac{1}{4}$ -amp fuse 1 is not open. A voltmeter shows no a-c voltage across either 450-volt leg of *T1S* (21-to-23 or 21-to-24), although there is voltage across *T1P*. Transformer *T1* smells roasted. It is found that its 900-volt winding is burned open, so a new *T1* transformer is necessary. However, since fuse 1 is not open, this overload and burnout were not caused by any fault in the d-c timing circuit. Tube 1 is checked, showing a circuit between its two anodes, which shorts *T1S*. This tube had given several years' service. With new tube 1 and *T1*, the panel returns to service. Other duplicate panels near by also have old rectifier tubes, darkened with use. All are replaced with new tubes to prevent possible similar failure.

6. The machine passes no welding current. The control (like Fig. 15E) seems normal, except that the firing thyatrons 5 and 6 sometimes flash greatly for the normal length of weld time.

Very little current is passing through the ignitrons, although the welder is set on a high tap and should be taking more than 500 amp. A voltmeter connected across the welding transformer shows normal voltage while the tubes fire. The trouble is in the secondary circuit of the welder. When the tubes fire, voltage is found across the secondary connections of the welding transformer, but there is no voltage at the electrode tips. Tapered elec-

trodes are used. It is found that one electrode had been loose in its holder and the operator had wrapped a paper strip around the electrode, so that it would be held more tightly. Removing this paper and using a new electrode corrected the trouble.

7. A spot-welder control (like Fig. 20A) gives poor timing, and the welds are not alike. The glow in tube 3 changes. Tubes 3 and 4 have been interchanged, but the tube in 3 socket still does not fire steadily.

It appears that tube 3 is not starting always at the same point on the voltage wave, so synchronous starting of the weld is not being obtained. When the starting contact closes, tube 2 looks normal, and passes current until the starting contact opens again (which is normal, since tube 2 operates from d.c.). An oscilloscope shows that the peak voltage of *T9S* is normal. A detailed check of resistors and capacitors around tube 2 finally shows that capacitor *C12* is shorted, between the grid and cathode of tube 2. Tube 2 therefore fires at once when the starting contact closes, and does not wait for *T9S* to fire it properly. This produces erratic firing of tube 3 and non-synchronous starting of the weld. With a new *C12* capacitor, proper operation is obtained.

8. An ignitron contactor used with a gun welder is frequently shut down by blown fuses and damaged copper oxide rectifiers.

It is seen that the operator has a habit of "plugging" the welder, or pressing the starting contact while the electrodes are still separated from the work. The contact tries to fire the ignitron tubes, but the magnetizing current of the welder transformer is not large enough to let the ignitrons fire. As a result, line voltage is applied continuously across the rectifiers every time the welder is plugged, and the low welder current blows the starter fuse. Either the operator must learn to close the starting switch only when the electrodes are pressed on the work, or else a dummy-load resistor<sup>4-11</sup> must be added across the welding transformer.

9. A welder having a synchronous timer with heat control (like Fig. 20A) suddenly flashes at the electrodes, burning the work. In a minute, smoke is coming out of the control enclosure, so the line switch and the control switch are opened. It is seen that transformer *T5* is smoking. After disconnecting its leads, it is found that both of its secondary windings are burned open, but its primary winding still shows a complete circuit. Of course, a new *T5* transformer is needed.

After the new *T5* transformer has been installed, the control switch is closed and everything seems normal, so the tubes are warmed for the required 5 min. Meanwhile, the main line switch is still open. The starting contact is closed, and tubes 2, 3 and 4 pass current as expected. Tubes 5 and 6 do not fire, for they have no anode voltage as long as the line switch is open. The line switch is then closed, while the control equipment is watched closely, and in less than a minute the new *T5* transformer also shows signs of getting hot. All switches are quickly opened. After letting *T5* cool down, only the control switch is again closed, and *T5* does not overheat. A voltmeter and oscilloscope are used to check and measure all the voltages in the grid circuit of tubes 5 and 6. The voltages of *T2S*, *T3S* and *T5S* are all normal. There is no voltage from the grid circuits to ground. When

the starting contact is closed, the tubes again behave normally. Next, the igniters are disconnected from the starter terminals (because they are the parts of the ignitron tubes most easily disconnected). The line switch is closed, and now *T5* does not overheat. This shows that whatever current overheats *T5* must also be passing through the igniters, and perhaps from the grid circuit of tube 5 to the grid circuit of tube 6. With switches open, an ohmmeter shows a low-resistance circuit between points 71 and 81, which is not normal. To locate this circuit, it is necessary to disconnect the various leads or devices of both grid circuits. The *T2S* windings are disconnected first, but the ohmmeter shows no circuit between terminals 74 and 84, or between 73 and 83. However, when the *T3S* windings are disconnected and hanging clear, a circuit is found between terminals 72 and 82. This shows that transformer *T3* is the real cause of all the trouble, for its two *T3S* windings have become shorted together, but not grounded. With terminals 72 and 82 shorted, and with the line switch closed, it is seen that current flows continuously from line 1 through tube-7 igniter to 71, through *T5S* to 72, shorted to 82, through the other *T5S* winding to 81, through the tube-8 igniter to terminal 3, and through the welding transformer to line 2 (or in the reverse direction). This current roasted the *T5S* windings, but transformer *T5* is not the cause of the trouble. A new *T3* transformer is also needed to correct the trouble.

10. A spot welder with a synchronous timer (like Fig. 15*E*) and a sequence control are moved to a new location in the plant and connected to the same 440-volt power supply. On the first trial operation, the squeeze-time relay of the sequence control does not close at once, but chatters or appears to bounce and operate several times. The line switch is still open, so there is no welding current that can be causing any sudden voltage drop in the main feeder, such as often makes sequence-control relays chatter.<sup>12-1</sup> Just as a trial, the sequence control is reconnected so that it is supplied from a nearby 115-volt lighting circuit. The 440-volt solenoid of the welder is still supplied from 440 volts. The trouble at once disappears. The electrician sees that, when he rewired the equipment in the new location, he used the same pair of small wires to supply the sequence control and also to supply the solenoid. When the foot switch closes, energizing the squeeze-time relay and the solenoid, the inrush current of the solenoid causes a voltage drop along the small wire. This drop in voltage makes the squeeze-time relay drop out again and then pick up, so that it seems to bounce. Both the sequence timer and the solenoid can be supplied from the same 440-volt supply, but large or separate wires must be used.

11. A spot welder gives erratic welds, and it is seen that the control (like Fig. 20*A*) seems to stutter in the middle of the spot weld. The tubes seem to fire twice. The relay *CR1* also seems to stutter or bounce.

An oscilloscope or a neon light<sup>2-4</sup> connected across the coil of *CR1* shows that the voltage disappears from across *CR1* coil for an instant after the weld has started. This welder uses a cam-operated switch to start the weld. It is found that this cam switch is bouncing, closing the circuit to *CR1* coil twice for each weld. The cam is smoothed off, and a spring is added to prevent further bouncing of this cam switch.

12. After a year of service, the welder begins to blow holes in every piece of work. On the synchronous control (like Fig. 20A), tubes 3 and 4 fire continuously, until the heat-control dial is turned to give much lower heat. At this low heat, all tubes work normally.

This requires an oscilloscope. It is found that the voltage of *T5S* is 60 degrees out of phase with the anode voltage of tube 6, instead of being 180 degrees out of phase. Also, the control voltage of transformer *T7* is neither in phase nor exactly out of phase with the line voltage between lines 1 and 2. Although the foreman insists that no connections have been changed, yet the oscilloscope shows that the control-circuit voltage at the panel is now supplied from a phase different from the welder. The control circuit is changed over to the same phase as the welder, and the equipment again works normally.

It is found that the wiring to the control and the welder had not been changed. However, when the equipment was first placed in service, control power was taken from another feeder (of the same phase), because the welder feeder had too much voltage drop during the weld. A high-voltage, three-phase cable supplying this other feeder had recently failed and had been replaced, without proper care to see that the same phase connections were made. This placed a different phase voltage on the other feeder supplying the control power of the panel. The cable failure was outside the building, so the foreman had not realized that conditions could be any different after power was again restored.

13. A spot welder control (like Fig. 15E) suddenly fails and the welder makes unusual noise. It is found that thyatron tube 6 has burst and that parts of the socket and near-by resistors are burned. This failure is so serious that all parts of the tube-6 grid and anode circuits must be checked before trying to repair the damage.

It is found that a 10-amp fuse is used as fuse 6 instead of the 3-amp fuse recommended for protection of tube 6. This 10-amp fuse was used because 3- or 5-amp fuses would blow as fast as they were replaced. Using the larger fuse kept the welder in production; no further check therefore was made.

An ohmmeter shows that ignitron tube 8 has only 8 ohms resistance, so it has become hard-starting<sup>4-16</sup> and should have been replaced. Thyatron tube 6' was punished so long by passing large currents to fire tube 8 that it finally shorted internally and burst with the surge of current passing through it. After the burned parts were replaced or cleaned and a new ignitron and thyatron were inserted, the welder returned to service.

If the investigation stops at this point, the trouble may happen again soon. All tubes seem to be working well. To make sure, the welder load current is measured with a pointer-stop ammeter and is found to be 30 amp. At this small current, new ignitrons sometimes may seem to fire well, but they will probably begin to fail to fire after a few weeks of such service. The ignitron (just replaced) refuses to fire steadily with this small current, blowing the 3- or 5-amp fuses. The large starter current permitted by the 10-amp fuse damages the igniter of the tube, reducing the igniter resistance and making it become a hard starter at any load.



14. A spot welder using control like Fig. 20A starts to give many poor welds. Without any change in setting, some welds are too cold while others are burned. The length of flow of welding current seems to change. A cycle recorder shows that the length of the weld is changing by a large amount. The control has been working 2 years without much attention. Since tube 3 is the thyatron that works directly from the timing circuit, a new tube is tried in socket 3, and the trouble disappears.

If no replacing tube had been available, an oscilloscope could have shown that this tube was defective, for it had very large arc drop. As shown in Fig. 22C, the voltage across the tube when it is passing current is much greater than the usual arc drop of 10 to 20 volts.

15. A seam welder (described in the next chapter, with control like Fig. 23A) gives defective welds because the heat seems to fade or disappear after

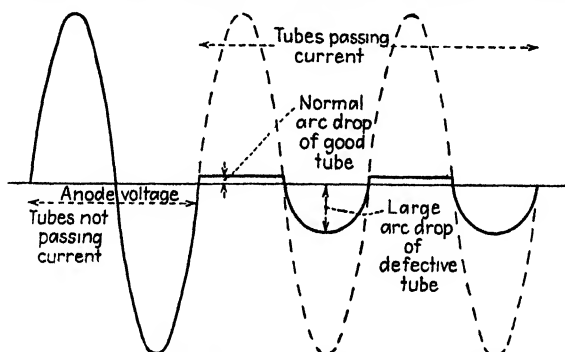

FIG. 22C.—Large arc drop of defective thyatron.

about 20 sec of continuous welding. At the start of each seam weld, the heat is normal. Quite a number of thyatron tubes have been used to keep this equipment in service. It is clear that the tubes are working differently at the beginning of the seam weld than they work 20 sec later. Such trouble is not expected from changes in resistors, transformers, etc. An oscilloscope (or pointer-stop voltmeter) is connected across the control supply to the panel and shows that the voltage drops 50 per cent while the ignitrons are passing current. How any equipment can be expected to work under conditions like this is a puzzle. When the voltage decreases one-half, the heat in the filaments of the thyratrons is only one-quarter of its usual amount. If the weld lasts only a second or two, there is enough heat stored in the filaments to prevent trouble. However, after 20 sec of operation at low voltage (even though the welding current flows 2 cycles *on* and 2 cycles *off*) the tube filaments cool down until they cannot supply the current necessary for firing the ignitrons properly. Operation at low filament voltage damages the thyratrons.

This condition is improved temporarily by supplying the control power from the 230-volt lighting feeder of the same phase, which provides more constant voltage. However, the welder or the power substation should be

moved, or very much larger cables should be installed, so that better voltage conditions will be provided to make the weld.

16. A seam welder has worked well for 3 months, using an all-tube seam-welder control like Fig. 24A. A second seam welder is then installed, supplied from the same control, whose ignitron tubes are large enough to handle the current of both welders. Two magnetic contactors are also installed, so that each welder can be operated by itself, or both together. One welder can be part way through its seam weld when the other welder starts or stops. With this arrangement, it is found that each welder works alone very well, but that the welds are poor when both welders are working at the same time.

This sounds like too much voltage drop in the power feeder, so that the welder voltage is much lower with two machines working than when just one is working. However, voltmeter readings show very little change in voltage, for the machines are close to the power transformer. There seems to be something about the operation of the second machine which is different from that of the first machine. A careful check soon shows that there is no discharge resistor<sup>4-4</sup> (or thyrite) connected across the welding transformer of the second machine. Such a resistor was furnished with the control and was properly installed with the first welder. When the second welder was added later, a separate resistor for it was forgotten. Adding this second resistor now corrects the trouble. Voltages produced in the second welding transformer, by the operation of the ignitron tubes (see Sec. 14-6, footnote), have been disturbing the grid circuits of the control equipment. Similar voltages produced in the first welding transformer are drained or by-passed, so they do not reach the control equipment.

17. A spot welder blows holes in every piece of work. Synchronous control is used (as in Fig. 15E). When the welder voltage is reduced by changing taps until no weld takes place, it is seen that the control works well and the welder cam switch is properly timed. This machine welds small aluminum pieces to aluminum plates. The operator and foreman blame the control.

Trials are made with new electrodes, using scrap-steel plates, and the welder works perfectly. When the aluminum parts are used again, the work and electrodes are spoiled. An oscilloscope shows that the current wave is normal. It seems that the work material is not right. New aluminum parts are made up and weld satisfactorily. Some of the old parts are checked in the laboratory. It is found that the small parts were cut from a rod of magnesium instead of aluminum, owing to a mistake in the stockroom.

## CHAPTER 23

### SEAM-WELDING CONTROL

The welding controls previously described are used for spot welding—welding metals together at one spot, then separating the electrodes and bringing them together again before welding at another spot. In contrast, seam welding makes a continuous row of spot welds without raising the electrodes off of the work. The electrodes are usually a pair of copper-alloy rolls or wheels which turn as the work passes between them. Often the welds are made so close together that they overlap, producing a continuous weld that is airtight. This usually requires from 4 to 20 welds per inch, depending on the metals used.

**23-1. Why Interrupt the Current in a Seam Weld?**—Seam welds were made 20 years ago by passing a continuous flow of current (a.c.) between the wheel electrodes. Similar welds are still made, usually on mild steel, without interrupting the current flow. This continuous flow of current produces a large amount of heat, which may overheat the whole piece of work but still not produce high enough temperatures between the rolls to fuse or weld the pieces together. However, if this current flows for only a few cycles, then stops for a few cycles before flowing again, a much larger current can flow without overheating the work. For example, if 1000 amp is needed to make a good weld, it may be found that this 1000-amp current cannot flow steadily without burning the metal. It is found that 700 amp is all that the metal can stand continuously. By letting the current flow for 4 cycles during each 8 cycles, the 1000-amp current produces no more total heat than a continuous flow of 700 amp. Yet, when 1000 amp does flow, it fuses and welds the metal. The strength of the weld made by this interrupted current is much greater than the strength of welds made with continuous current flow. The best seam or line weld becomes merely a rapid succession of spot welds, each of which must be timed and controlled separately. Many seam welders now use current pulses as short as 1 or  $1\frac{1}{2}$  cycles.

**23-2. Earlier Seam-welding Controls.**—For many years seam welders used motor-driven mechanical interrupters to control current impulses as short as 4 to 6 cycles each. Synchronous driving motors and fine mechanical adjustments helped such interrupters to close and open the circuit near the zero point of the current wave. Some of the first electron-tube welder controls consisted of grid-controlled mercury-pool tubes whose current flow was controlled by motor-driven contacts in their grid circuits. This arrangement decreased the noise and wear of interrupter contacts. When an all-tube timing circuit was used to control these power tubes, it was possible to get better and faster seam welding.

The mercury-pool tubes were partly replaced by large heated thyratron tubes (Type FG-41), grid-controlled by a tube circuit. To be able to control larger welders, these thyratrons operated at higher voltages (2200 to 6600 volts a.c.) supplied by a series transformer in the 220- or 440-volt welder circuit. These controls, many of which are still in service, have been described by D. E. Chambers in the January, 1935, issue of *Electrical Engineering*.

Another seam-welding control used early types of high-current ignitron power tubes, which were pumped to the proper operating pressure each time they were placed in service. All these earlier types have given way to seam-welding controls using permanently sealed ignitrons.

Almost all modern seam-welding controls provide synchronous timing,<sup>15-1</sup> starting each current impulse at the proper point on the voltage wave. Some of these equipments control and time the seam weld entirely by tube circuits, like the controls described in Sec. 23-10 and Chap. 24. The synchronous seam-welder control described below gives equally good welds, and is especially well-suited to high-production seam welding.

**23-3. Seam-welder Control with Timing Chain (CR7503-B102).**—This synchronous control, shown in Fig. 23A, mounts a pair of ignitron tubes behind the panel, which are controlled or fired by the two thyratrons shown in front. These are the only tubes used, and they provide phase-shift heat control of the seam welder. There is no rectifier tube as in previous controls, since a d-c supply is not needed for timing purposes. All the timing or selecting of those cycles when welding current may

flow is done by a chain, driven by a synchronous motor so that the chain moves exactly in step with the a-c power supplied to the welder. Another view of this motor and chain is shown in

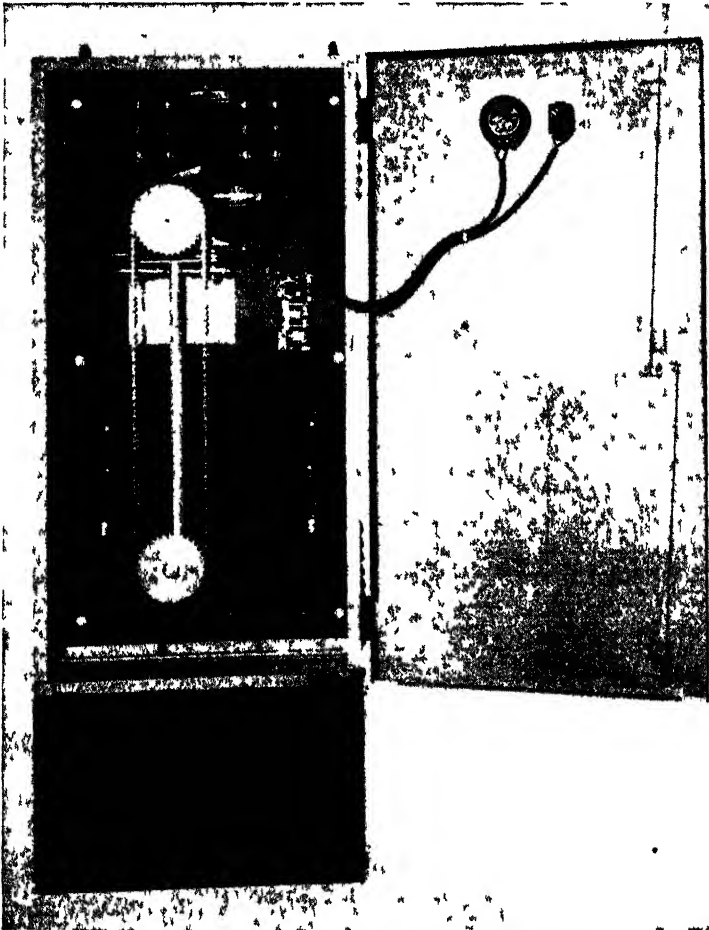

FIG. 23A.—Seam-welding control CR7503-B102.

Fig. 23B. The chain carries a large number of contact buttons, part of which are metal and the rest of which are made of hard rubber. These buttons can be pulled from the chain like grapes, and then shoved back onto the chain in any arrangement or

pattern desired. The motor drives this chain at such a speed that exactly 120 of these buttons pass by the pointer and contact brush every second. Therefore, each button corresponds to a half-cycle. As each metal button touches the contact brush, it completes a circuit which makes one of the ignitron tubes pass current to the welder. However, a black or rubber button does not close this circuit, so it represents a half-cycle when there is no

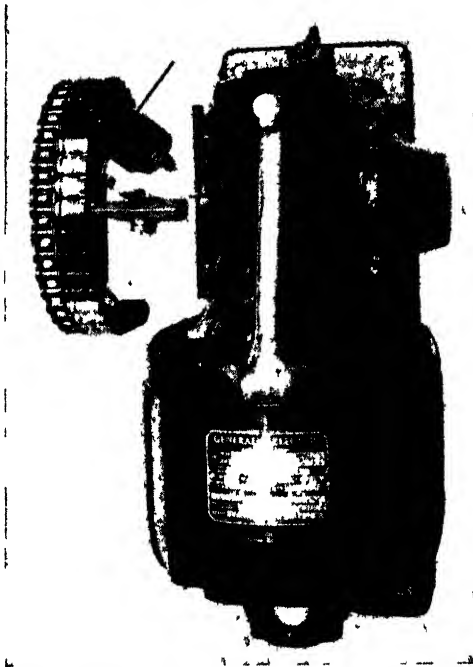

FIG 23B.—Motor-driven timing chain for seam-welding.

flow of welding current. In Fig. 23B the chain is shown with four metal buttons together, followed by four black buttons. This arrangement makes the ignitrons pass current for 2 cycles "on," with 2 cycles "off" between impulses.

The elementary<sup>7-4</sup> diagram of this seam-welder control is given in Fig. 23C. The thyratrons and ignitrons are connected together as shown in Fig. 17A, and the phase-shifted grid circuits of thyatron tubes 3 and 4 are similar to Fig. 20C, while the phase-shifting control circuit has been shown in Fig. 19E. The new

portion is the timing circuit which includes the motor-driven chain. The discharge resistor  $R6$  is described in Sec. 4-4.

**23-4. A-c Supply and Safety Circuits.**—In Fig. 23C transformers  $T1$  and  $T2$  furnish the supply voltages for the panel.

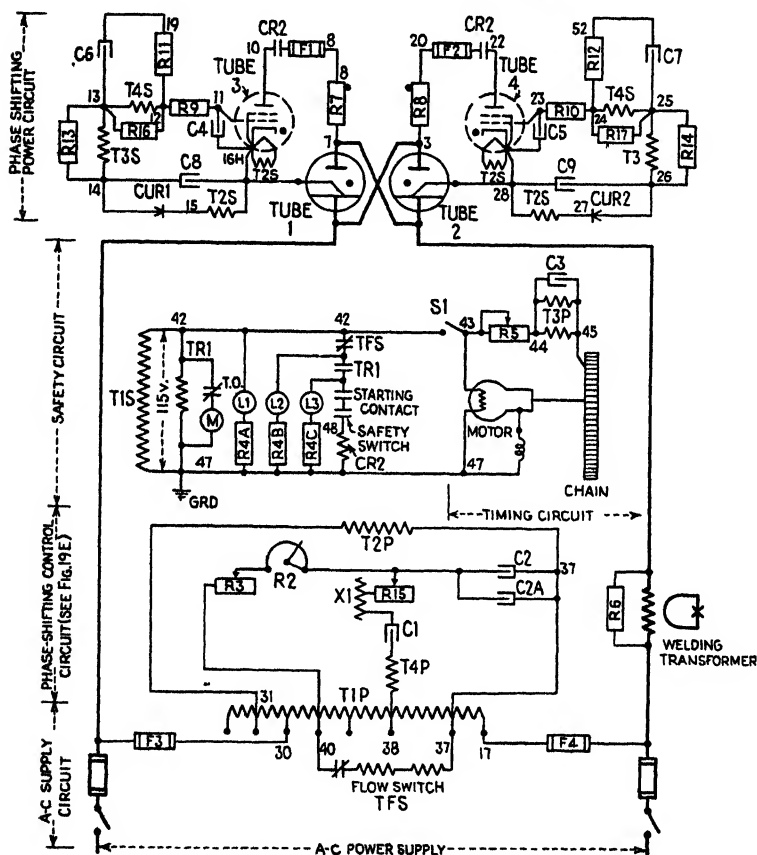

Fig. 23C.—Elementary diagram of CR7503-B102 seam-welding control.

All the a-c control power passes through 10-amp fuses  $F3$  and  $F4$ . As described in Sec. 16-1, this control may be connected through a separate switch so that the tubes remain hot even when the line switch is open. The wires (30 and 17) from  $F3$  and  $F4$  must be connected to  $T1P$  for the proper line voltage, so that a voltmeter will measure close to 460 volts between panel terminals 31 and 37, or across  $T2P$ .

The secondary winding of transformer *T1* furnishes 115-volt power to operate the 5-min time-delay relay<sup>16-4</sup> *TR1* and the safety circuit that energizes *CR2*. Before *CR2* can pick up and permit a weld to be made, the circuit must be completed from 42 to 48, which means that *TR1* must have finished its 5-min timing, there must be proper cooling water of the ignitron tubes to close *TFS*, and the safety switch on the welder must be closed. The welding current begins to flow only when the starting contact is closed by a cam or pressure switch, after the welding rolls are pressed on the work. Notice that *CR2* is energized only when the seam welder is ready to make a weld. The contacts of *CR2* must close before any tubes can normally pass current, and these *CR2* contacts open again before the welder rolls are separated from the work, when the seam weld is finished.

**23-5. The Motor-chain Timing Circuit.**—When switch *S1* is closed on the front door of the control equipment, this starts the synchronous motor that drives the timing chain. This motor operates from 115 volts a.c., using current that passes from 42 through *S1*, through the motor to the transformer terminal 47, which is grounded to prevent anyone from getting a shock by touching the motor or gear box. Closing *S1* also completes the circuit through *R5* and *T3P*, through the timing chain, through the sprocket, gear box, and the long vertical bar beneath the motor, to the grounded terminal 47. Whenever a metal button on the chain completes this circuit, current passes through *T3P*, which makes the tubes pass welding current as described later.

Each metal button completes the timing circuit, by touching against a metal contact brush (a piece of spring steel shown in Fig. 23*B*). This metal brush is kept at the right length, in spite of wear, by keeping its contact end lined up with the fixed pointer. The motor-driven sprocket is carefully located on the shaft so that it makes each button touch the contact brush just at the right time.\* If one metal button permits tube 3 to fire, then the next button controls tube 4. There is no leading-tube-trailing-tube circuit in this control, so tubes 3 and 4 are controlled individually. However, tubes 3 and 4 do not fire at that exact instant when the metal buttons touch the contact brush, for

\* An oscilloscope connected across *T3P*, 44-to-45, should show an unbroken sine wave.



their firing is controlled and delayed by their own individual phase-shifting grid circuits.

**23-6. Phase-shifted Power Circuit.**—In Fig. 23C the flow of line current to the welder passes through tubes 1, 2, 3 and 4, and the circuit near these tubes is called the *power circuit*. As described before in a similar circuit,<sup>20-3</sup> the circuit of tube 4 of Fig. 23C is the same as the circuit of tube 3. For every device in the tube-4 circuit, there is a similar device in the tube-3 circuit. The grid circuit of tube 4 is shown in detail in Fig. 23D, which may be compared with Fig. 20C. (Although the numbering of

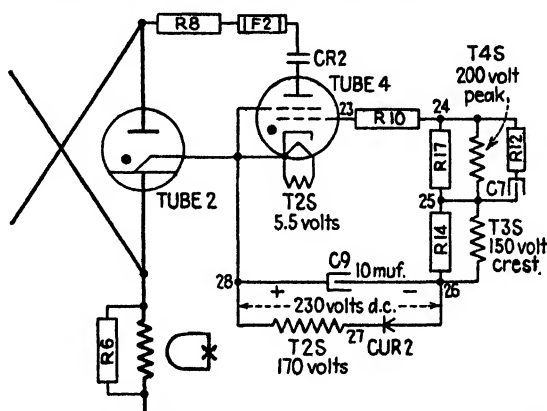

FIG. 23D.—Grid circuit of firing tube with d-c bias.

tubes, resistors and transformers differs in Figs. 23D and 20C, the similar purposes of these parts are shown by their locations in the diagrams.) The grid-to-cathode capacitor  $C5$  is omitted.<sup>9-13</sup>

In Fig. 23D tube 4 is kept from firing by the voltage of  $T2S$ . The 170 volts a.c. of  $T2S$  is rectified by passing through copper oxide rectifier  $CUR2$  in only one direction, so as to charge capacitor  $C9$ . (This circuit produces a negative or hold-off bias on the grid of tube 4, in the same way as the circuit described in Sec. 18-8.) During each half-cycle when the anode of tube 4 is negative,  $T2S$  charges  $C9$  to the crest value of its voltage (see footnote of Sec. 7-14), or to about 230 volts.\* Capacitor  $C9$  is so large (10 mu f) that it keeps this 230-volt potential

\* In Fig. 23D no grid current flows during the negative half-cycle while  $C9$  is being charged, so there is no blue glow in tube 4 except during a weld.

across its terminals constantly, acting like a 230-volt battery, to keep terminal 26 always more negative than the cathode 28 of tube 4, and producing a steady d-c bias on the grid of tube 4.

The voltages across *T3S* and *T4S* combine to "turn on" tube 4. Transformer *T4* is a peaking transformer<sup>20-7</sup> which produces a steep narrow voltage peak each half-cycle, as shown in Fig. 23*E*. Transformer *T3* produces voltage across its *T3S* windings only when a metal button on the timing chain com-

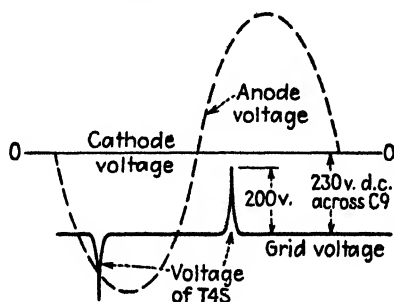

FIG. 23*E*.—Grid voltage (d-c bias), peaker ineffective.

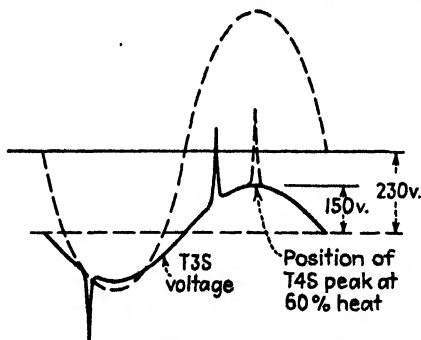

FIG. 23*F*.—Grid voltage (d-c bias), peaker effective.

pletes the circuit to *T3P*, as already described. However, when *S1* is open and the motor is not running, or when a black button touches the brush contact, keeping open the circuit to *T3P*, at such times there is no *T3S* voltage, so the voltage at the grid of tube 4 is as shown in Fig. 23*E*.\* It is seen that the 200-volt "turn-on" peak voltage of *T4S* is not high enough to reach up to the 0-0 line. The grid of tube 4 is still 30 volts more negative than its cathode, so tube 4 cannot fire. However, when trans-

\* Compare Fig. 23*E* with Fig. 20*D*; Fig. 23*F* with Fig. 20*F*.

former *T3* is energized, *T3S* produces a voltage wave whose crest value is about 150 volts, as shown in Fig. 23*F*\*. This *T3S* voltage adds to or raises the *T4S* peak, so that it now reaches far above the 0-0 line, thereby making the grid of tube 4 positive. Since tube 4 is fired by the narrow peak of *T4S*, tube 4 can be made to fire earlier or later in its half-cycle by changing the position of the voltage of *T4*. This provides phase-shift heat control of the welder, as described in Sec. 19-3.

The position of the *T4P* voltage is changed by the phase-shifting control circuit shown in the lower part of Fig. 23*C*. This circuit is explained in Secs. 19-6 and 19-7.†

Since this seam-welder panel includes heat control, review Sec. 19-10 which gives suggestions for the proper use of heat control, and also Sec. 19-12 concerning the load rating of phase-shifted ignitron tubes.

**23-7. Arranging Buttons on the Timing Chain.**—Since one of the ignitrons passes welder current during any half-cycle for which there is a metal button on the chain, the time length of each weld impulse depends on the number of metal buttons arranged together on the chain. Six metal buttons together cause welding current to flow for 3 cycles. If three black buttons come next, followed by six more metal buttons, there is a current interruption of  $1\frac{1}{2}$  cycles (off time) between the two 3-cycle (on time) impulses. It is possible to arrange the buttons in any desired order, and links can be added to or removed from the chain so as to give the desired total number of buttons. In most seam welding, the chain is arranged to give a continuous succession of “on” and “off” times (also called *heat* and *cool* times). If 6 metal buttons are followed by 3 black buttons, then the rest of the chain is also arranged in groups of 6 metal buttons

\* This voltage is factory-adjusted by *R5*.

† To make the description in Chap. 19 also apply to Fig. 23*C*, note the following changes in numbering:

FIG. 19*E*    FIG. 23*C*

<i>T7</i>	=	<i>T1</i>
<i>T2</i>	=	<i>T4</i>
<i>R30</i>	=	<i>R18</i>
<i>C13</i>	=	<i>C2</i>
<i>R29</i>	=	<i>R3</i>
<i>X2</i>	=	<i>X1</i>
<i>C14</i>	=	<i>C1</i>

and 3 black buttons. Of course, the total number of buttons used in this chain must be some multiple of 9, which is the sum of 6 "on" and 3 "off" buttons. If the chain originally has 100 buttons, it is necessary to add 8 buttons, or to remove either 1 or 10 buttons. Since there are 2 buttons supported by each chain link, this change requires opening the chain to add 4 links or to remove 5 links. A special link is also furnished which adds only one button when desired.

For short timing, the total chain usually needs to be only long enough to pass over the two sprockets. The lower sprocket is an idler which merely hangs inside the chain, so the chain may be shortened until the idler turns within several inches of the upper

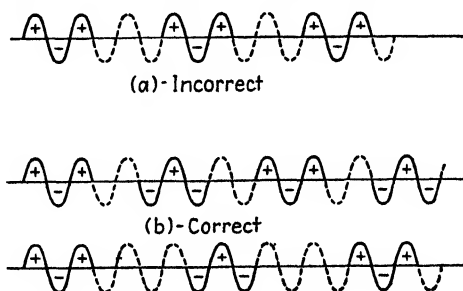

FIG. 23G.—Timing-chain button arrangements for odd-half-cycle welds.

sprocket. In this way, there may be enough buttons and links to make several timing chains. To change the seam-welder timing from one arrangement to another, it is easier and quicker to change chains than to rearrange the buttons.

Whenever the buttons are arranged for "on" times such as  $1\frac{1}{2}$ ,  $3\frac{1}{2}$  or  $7\frac{1}{2}$  cycles, it is necessary to use an even number of black buttons for the "off" time. If, as shown in *a* of Fig. 23G, the buttons are arranged to give  $1\frac{1}{2}$  cycles "on" and  $1\frac{1}{2}$  cycles "off," there are twice as many half-cycles above the 0-0 line as there are half-cycles below the line. Such timing must not be used, for it causes the welding transformer to saturate, draw too much current and blow the line fuse or breaker. These buttons must be arranged to give either 1 cycle or 2 cycles "off." As shown in *b* of Fig. 23G, the number of half-cycles above the line is now equal to the number below the line during 1 sec of time.

When an even number of metal buttons is grouped together to produce "on" time such as 1, 2, 3 or 4 cycles, the total numbers of

half-cycles above and below the line are always equal. It is still best to select the number of black buttons, as in *b* of Fig. 23H instead of as in *a*, so as always to start each "on" time with  $\epsilon$  polarity opposite to that of the last previous half-cycle of current flow. This prevents transient currents caused by the magnetism remaining in the welding transformer from the preceding current flow.<sup>14-9</sup>

Aside from the above points, the number of buttons in each group depends only on the weld itself. If many buttons are used in each "on" or "off" period, this reduces the number of weld impulses or spots during each second, and this also reduces

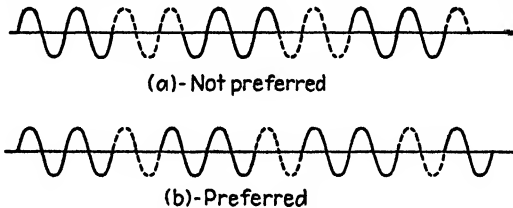

FIG. 23H.—Timing-chain button arrangements for even-half-cycle welds.

the speed at which the welder can produce an overlapping gastight weld. However, if there are too few buttons in each group, each current impulse may be too short to fuse or weld the metal.

**23-8. Seam-welding Speed or Spots per Minute.**—The turning speed of the seam-welder rolls, measured in inches per minute, is usually limited by the number of current interruptions per minute. With the setting of 2 cycles "on," 2 cycles "off" (popular for welding gasoline tanks), the total time per weld spot is 4 cycles. Since 60-cycle a-c power gives 3600 cycles per minute, there are exactly 900 of these weld spots per minute. At this rate of 900 spots per minute, if the rolls travel over the work at 180 in. per minute, the resulting weld will have 5 weld spots per inch.

If a certain weld requires 8 weld spots per inch, and the metal thickness requires that current must flow for 3 cycles to make each weld spot, what is the greatest speed of the welder roll? The "off" time is not given, but probably at least 2 cycles "off" is necessary. The total time required per spot is 3 "on" + 2 "off" = 5 cycles.

$$\frac{3600 \text{ cycles per minute}}{5 \text{ cycles per spot}} = 720 \text{ spots per minute}$$

$$\frac{720 \text{ spots per minute}}{8 \text{ spots per inch}} = 90 \text{ in. per minute}$$

The welder rolls must not travel faster than 90 in. per minute to give the required weld.

To tack-weld steel strips together at 40 ft per minute, with current impulses each  $\frac{1}{2}$  cycle long, how far apart will these tack welds be? Obviously, by increasing the "off" time, the spots can be made as far apart as desired, within the limits of the available chain. With a chain of 1 metal button and 60 black buttons (not 59 or 61), there is one tack weld in each  $30\frac{1}{2}$ -cycle period, or approximately 2 welds per second. Traveling at 480 in. per minute, the steel moves 8 in. per second, so the tack welds are about 4 in. apart. The closest spacing of these welds is obtained with a chain arrangement of 1 metal button and 2 black buttons, giving 2 welds every 3 cycles, or 40 welds each second. The steel, moving 8 in. each second, receives 5 welds per inch.

**23-9. Program Welding.**—A modified form of this seam-welder control with timing chain is well suited to controlling special pulsation welds or varying-heat cycles, such as the following program: 3 heat periods of 8 cycles each, at full heat, separated by 6-cycle cool periods; followed by 4 heat periods of 10 cycles each at full heat, separated by 9-cycle cool periods; followed by an annealing period at reduced heat, 50 cycles long. Such a weld program requires a total time of 168 cycles, or nearly 3 sec, so a longer timing chain is required, with additional sprockets. Each button is made to control a whole cycle instead of only a half-cycle.

With such an endless chain, it is necessary to start the weld at one certain point on the chain. This is done by a "flying contact" connected to this point of the chain, which completes a circuit in series with *S1* (Fig. 23C). When the starting contact closes at the wrong portion of the chain, no welding current flows until the flying contact passes. Thereafter the pulses of current follow in the desired order, and the circuit is then opened by another flying contact. The change from full heat to reduced heat is performed by a third flying contact, which causes a change from one heat dial to another, to phase-shift the ignitrons to a lower heat.

**23-10. All-tube Seam-welding Control (CR7503-B110).\*** Other equipment for controlling a seam welder is shown in Fig. 23I. Instead of a timing chain, this equipment uses only tube circuits and has no moving parts. The turning of a small control

\* M. E. Bivens, Seam and Pulsation Welding Controls, *Electronics*, September, 1942.

dial selects the length of each current impulse, or heat time. Likewise, the cool time between impulses is set by turning another dial. These changes in timing can be made even while the machine continues welding.

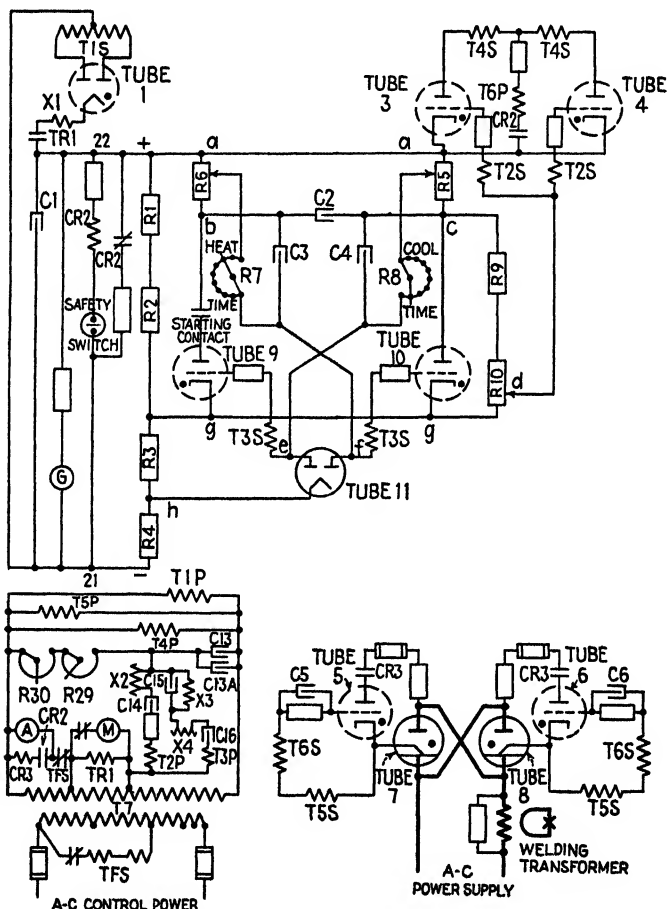

Fig. 23I.—Elementary diagram of CR7503-B110 all-tube seam-welding control.

As shown in Fig. 23I, this equipment uses two ignitrons, six thyratrons and two rectifier tubes. The main current supply to the welding transformer passes through ignitron tubes 7 and 8, which are fired by tubes 5 and 6, in much the same way as shown in Fig. 19E. None of these tubes can fire unless tubes 3 and 4

fire first. In a study of the timing circuit, it will be found that tubes 3 and 4 can fire only when tube 9 is passing current, but they do not fire while tube 10 passes current. Tubes 9 and 10 alternate; tube 9 passes current only during each heat time, but tube 10 passes current during each cool time and also while the starting switch is open.

Tube 1 is the usual rectifier which, together with reactor  $X1$  and capacitor  $C1$ , produces a d-c supply between positive point 22 (top) and negative point 21 (bottom). Rectifier tube 11 acts like a switch which connects the control grids of tubes 9 and 10 to point  $h$  part of the time.

The a-c control power is supplied through transformer  $T7$ , to energize  $T1$ ,  $T4$  and  $T5$ . Certain details such as tube filament or heater transformer windings are not shown in Fig. 23I, although they are included in the complete equipment. Above  $T7$  is shown the phase-shifting circuit,<sup>19-6</sup> in which resistor  $R30$  is turned so as to control the peaking transformer  $T2P$  and thereby change the amount of heat or current at the weld. Notice that  $R30$  also controls another peaking transformer  $T3P$ ,\* whose peak occurs at a different point in the cycle because of  $C15$  and  $X3$ . For  $X2$  and  $C14$  or  $X4$  and  $C16$ , see Sec. 19-8.

In Fig. 23I, notice that tubes 9 and 10 operate on the d-c supply between points  $a$  and  $g$ . When thyratrons operate on d.c., their grids control the starting of anode current flow, but cannot stop such flow. To stop anode current in tube 10, the voltage at point  $c$  (anode of tube 10) must be made more negative than point  $g$  (cathode) for just an instant, long enough to let the grid regain control. This is done† by capacitor  $C2$ , as shown below.

**23-11. The All-tube Timing Circuit.**—After the 5-min tube-warming period,  $TR1$  contact closes (below tube 1 in Fig. 23I). The starting switch is still open (see contact above tube 9), and tube 10 is passing direct current. To see why, notice that the grid of tube 10 is connected to point  $f$ , and through tube 11 to  $h$ . In the voltage-divider<sup>16-11</sup> consisting of  $R1$ ,  $R2$ ,  $R3$  and

\*  $T1$  and  $T3$  are constant-voltage transformers, which decrease the effect of supply-voltage variations.

† This timing circuit, where two thyratrons are connected with a capacitor so that, when one tube fires, it causes the other tube to stop firing, is a form of the parallel type of thyatron inverter.



R4, point *h* is more negative than *g*, so the grid of tube 10 is more negative than its cathode *g*. However, the first turn-on voltage peak of T3S forces the grid of tube 10 positive for an instant, so tube 10 fires and passes direct current steadily thereafter.

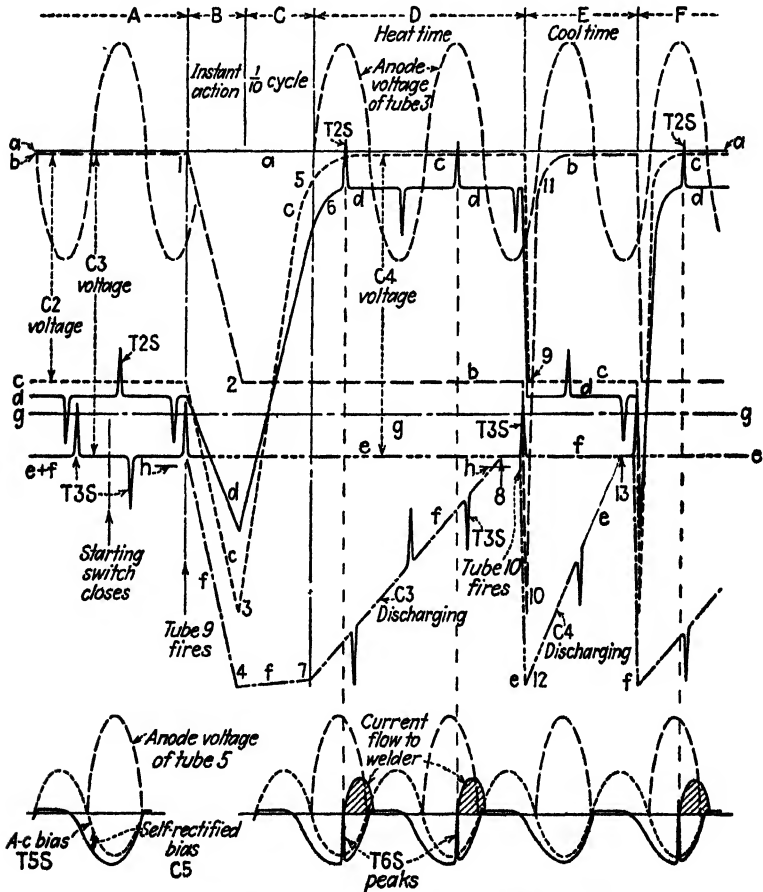

FIG. 23J.—Changes in circuit voltages in all-tube seam-welding control.

Figure 23J shows the potentials at various points in the circuit, in part A before the starting switch is closed, and later during the seam-welding operation. In part A it is seen that tube 10 is passing current, and point *c* is only a small amount above point *g*. (This small amount is the arc drop of tube 10.) Point *d* is connected to the grids of tubes 3 and 4 and is at a potential part way

between *c* and *g* (because of voltage divider *R9* and *R10*). The cathodes of tubes 3 and 4 are at potential *a*. The *d* grid potential is so far below *a* that even the peak voltages from *T2S* are unable to reach high enough to fire tubes 3 or 4. Therefore tubes 5, 6, 7 and 8 are not firing, and the welder is not energized. Since the starting switch is open, tube 9 is not drawing current through *R6*, and *b* is near the same potential as *a*. Capacitor *C2* has been charged to the voltage difference between *b* and *c*, and *C3* has been charged to the voltage difference between *b* and *f*, by current flowing from *a* through *R6* into *C3* and through tube 11 to point *h*.

After the welding rolls are pressed onto the work, the starting switch closes, applying voltage to the anode of tube 9. However, tube 9 does not fire instantly, for its grid is at the negative potential of *e*, which is connected through tube 11 to *h*. On the next positive voltage peak of *T3S*, the grid of tube 9 is made positive and tube 9 passes current. This current flows from *a* through *R6* and the starting contact, through tube 9 to *g* (and through *R3* and *R4* to 21). The potential at *b* instantly drops close to *g*.

In part *B* of Fig. 23*J* this quick drop is shown between points 1 and 2. At the same instant, the potential of *c* drops the same amount, to point 3, because capacitor *C2* cannot instantly lose the voltage across it. Likewise, the potential of point *f* is forced the same distance downward to point 4, because *C3* cannot instantly change the voltage between its terminals. (As *f* becomes more negative than *h*, current stops flowing through the right-hand side of tube 11.)

Notice that *c* (anode of tube 10) has been forced below *g* (cathode of tube 10). This stops the current flow through thyratron tube 10 and *R5*, so the potential of *c* tries to rise to *a* just as soon as *C2* will let it. With tube 9 passing current and tube 10 no longer passing current, capacitor *C2* suddenly finds itself with its *b* end connected to a lower potential than its *c* end, so *C2* quickly discharges and recharges in the reverse direction (by current flowing from *a* through *R5* to *C2*, and through tube 9, *R3* and *R4* to point 21). *C2* makes this change in less than  $\frac{1}{10}$  cycle. In Fig. 23*J* parts *B* and *C* are purposely made wider so as to show the many changes that take place almost instantly. Remember that part *D* starts less than  $\frac{1}{10}$  cycle later than the end of part *A*. Within this  $\frac{1}{10}$  cycle after current stops flowing through tube 10,

the potential of *c* has risen close to *a* at 5, so the anode of tube 10 is again positive. (*C2* is now charged (+) at *c*, (-) at *b*. *C4* has become charged to the large voltage between *c* and *e*.)

Meanwhile, the grid *f* of tube 10 has been made negative at 4. Since *C3* does not lose its voltage charge quickly like *C2*, the grid *f* remains negative during the entire heat time, keeping tube 10 from firing. Meanwhile, the potential at *d* (grid voltage of tubes 3 and 4) is always part way between *c* and *g*. When *c* rises to 5, *d* rises to point 6, which is still far enough below *a* (cathode of tubes 3 and 4) so that tube 3 is not fired until the next positive voltage peak of *T2S* reaches above *a*. As long as *d* remains this close to *a*, tubes 3 and 4 both continue to be fired each cycle by these voltage peaks of *T2S*. As tube 3 fires, it suddenly completes the circuit (upper portion of Fig. 23I), letting *T4S* force current through tube 3, to 22, through *CR2* contact (operated by safety switch) and into peaking transformer *T6*. As shown later, this causes tube 5 to fire ignitron 7.

During these cycles while current flows to make a weld (Fig. 23J shows 2 cycles heat time in part *D*, 1 cycle cool time in part *E*), the potential at *f* has been gradually rising, as *C3* discharges through *R6* and the heat-time adjustment *R7*. With *R7* set for 2 cycles, there is a time delay of 2 cycles before the potential at *f* (in Fig. 23J) rises close to *g\** at 8 and lets the next positive voltage peak of *T3S* fire tube 10, to start the cool time.

When current passes through tube 10 and *R5*, the potential at *c* again drops close to *g*, as shown at 9. This voltage change at *c* also forces *b* (anode of tube 9) negative, to point 10, stopping the current flow through tube 9. Again *C2* finds that its (+) end is connected to a lower potential than its (-) end, so it discharges and recharges in less than  $\frac{1}{10}$  cycle. This lets *b* rise from 10 up to 11, or back to the same potential from which it started at point 1.

As *c* drops to point 9, point *d* (grids of tubes 3 and 4) drops close to *g*, so that the turn-on peaks of *T2S* cannot fire tubes 3 and 4 during the next cycle. Since this prevents tubes 5, 6, 7 and 8 from firing, the welder receives no current and this is the cool time. The length of this cool time depends on how long *C4*

\* At point 8 the potential of *f* again becomes more positive than *h*, so the right-hand side of tube 11 passes current, preventing *f* from becoming still more positive.

requires to discharge before it lets point  $e$  return above  $h$ . In Fig. 23J it is seen that  $e$  remains close to  $h$  all during the heat time, but  $C4$  forces  $e$  down to 12 when tube 10 fires.  $C4$  gradually discharges through  $R5$  and the cool-time adjustment  $R8$ . If  $R8$  is set for only 1 cycle of cool time, there is so little resistance left in  $R8$  that  $C4$  discharges quickly, letting  $e$  rise from 12 up to 13 in less than 1 cycle. The next positive voltage peak of  $T3S$  again fires tube 9, which starts another heat time and flow of welding current. Tubes 9 and 10 continue to start these alternate heat and cool times as long as the starting contact remains closed.

As mentioned above, tubes 3 and 4 fire at the instants when the  $T2S$  peaks occur. The position of these peaks in each a-c cycle is controlled\* by  $R30$  in the phase-shifting network (lower portion of Fig. 23I).

When tubes 3 or 4 fire, the sudden flow of current into  $T6P$  causes a high voltage peak to appear in the grid circuit of tubes 5 and 6. The grids of tubes 5 and 6 are usually kept from firing because of a negative a-c bias from  $T5S$  and a self-rectified bias across  $C5$  or  $C6$ . The lower portion of Fig. 23J shows the anode voltage and grid voltage of tube 5. At the same instant when  $T2S$  fires tube 3, the voltage peak of  $T6S$  fires tube 5. One half-cycle later, when  $T2S$  fires tube 4, the corresponding  $T6S$  voltage peak fires tube 6. Tubes 5 and 6 fire their ignitron tubes 7 and 8 as previously described.

Tube 9 fires to start each heat time, and tube 10 starts each cool time. Each tube fires only during half-cycles of the same polarity. As a result, the heat time and the cool time are controlled in one-cycle steps, and each heat-time impulse starts with a polarity opposite to that which completed the previous impulse.

**23-12. Seam Welding with a Spot-weld Timer.**—Although the following combination is not to be compared with a complete seam-welder control, it is possible to obtain certain seam-welding operations by combining a synchronous spot-weld timer (see Sec. 15-2 or 20-1) with a sequence control similar to that described in Sec.

\* When  $R30$  is turned so as to decrease its resistance and advance the position of the  $T2S$  peaks, and thereby increases the heat at the weld, this change in  $R30$  also advances the position of the  $T3S$  peaks, so that the potential at  $d$  always reaches point 6 (Fig. 23J) well ahead of the next turn-on peak of  $T2S$ .

20-12, but having a single time-delay relay. Each heat time is started and timed by the synchronous timer, letting the sequence control time each cool period. Such operation is limited to a seam weld made with at least 2 cycles heat and 3 cycles cool. The constant heat in the weld depends on the accuracy of the sequence control as well as on the operation of the synchronous timer.

## CHAPTER 24

### ALL-TUBE CONTROL FOR SEAM, SPOT AND PULSATION WELDING

For the control of a-c welding, the most complete equipment includes tube-operated circuits to control a seam welder, or a spot welder producing either a single-spot or a pulsation weld. Phase-shift heat control is provided.

**24-1. Description of Control (CR7503-C107).**—This control equipment is shown in Fig. 24A. All circuits are tube-operated, and the main power current passes through two ignitron tubes mounted in back of the panel. The other tubes include five FG-95 thyratrons, two FG-17 thyratrons, two GE-83 rectifiers and three neon glow tubes. Figure 24B shows the control dials, switches and buttons mounted on the front door of the equipment, numbered as shown later in the circuit diagram.

A single spot weld is made with switch *S4* pushed down and *R36* turned to number 1 on its dial, so as to give just one impulse or spot. Dial *R9* selects the spot length and *R30* selects the amount of heat by phase-shift heat control.<sup>19-3</sup>

If *R36* is now turned clockwise to permit more than one spot, this produces a pulsation<sup>10-1</sup> weld. *R9* now selects the length of each heat time of the pulsation weld and *R35* selects the length of cool time between the current impulses. If *R36* is set to give, say, 4 spots, this setting always produces four separate current impulses, and it makes no difference whether *R9* and *R35* are set for short time or for long time. *R30* selects the amount of heat during each current impulse of the pulsation weld.

A seam weld is made with switch *S4* pushed up. *R36* now has no effect. The seam weld<sup>22-1</sup> is made by an interrupted current as in a pulsation weld, but the welding current is turned on and off repeatedly until the operator releases his foot switch to end the weld. *R9* selects the length of each *heat* time, and *R35* selects the *cool* time. *R30* selects the amount of heat during each time when current flows.

Since these various forms of welding can all be produced by the same control, this equipment is well suited for experimental welding, or for plants wishing to change frequently from one type of welding to another. However, for the single purpose of pulsation welding, this equipment offers little advantage over a

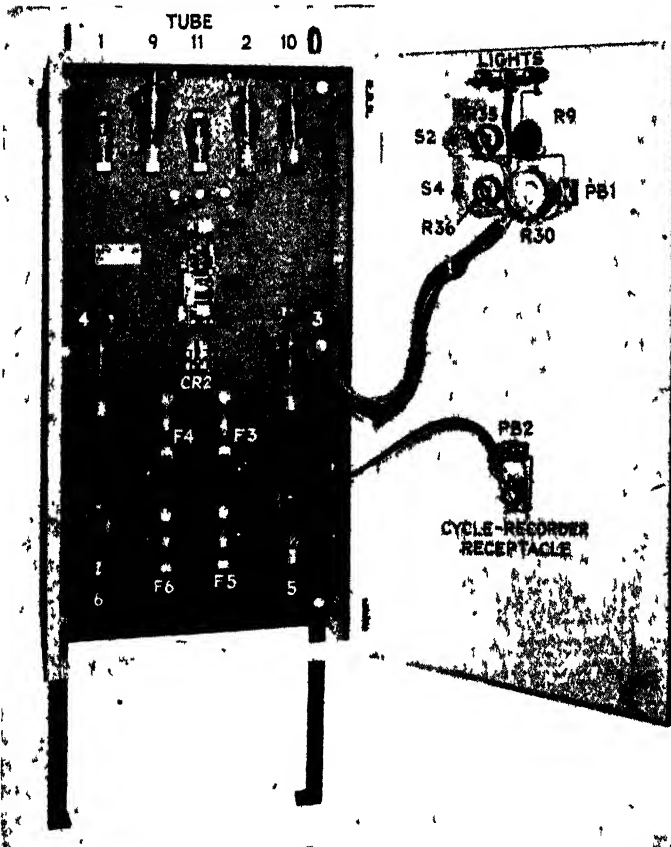

FIG 24A —All-tube spot-, pulsation- and seam-welding control (CR7503-C107).

synchronous spot-welding timer<sup>20-1</sup> and proper sequence control. Similarly, for the single purpose of seam welding (in production that does not require frequent changes of timing), this complete equipment offers little advantage over the seam-welding control described in Secs. 23-3 and 23-10,

**24-2. Elementary Diagram.**—The complete elementary diagram of this equipment (CR7503-C107) is shown in Figs. 24C and 24D combined. Nearly all of Fig. 24D is the same as the lower portion of Fig. 20A. The a-c supply circuit (bottom of Fig. 24D), the water-flow switch *TFS* and the 5-min time relay

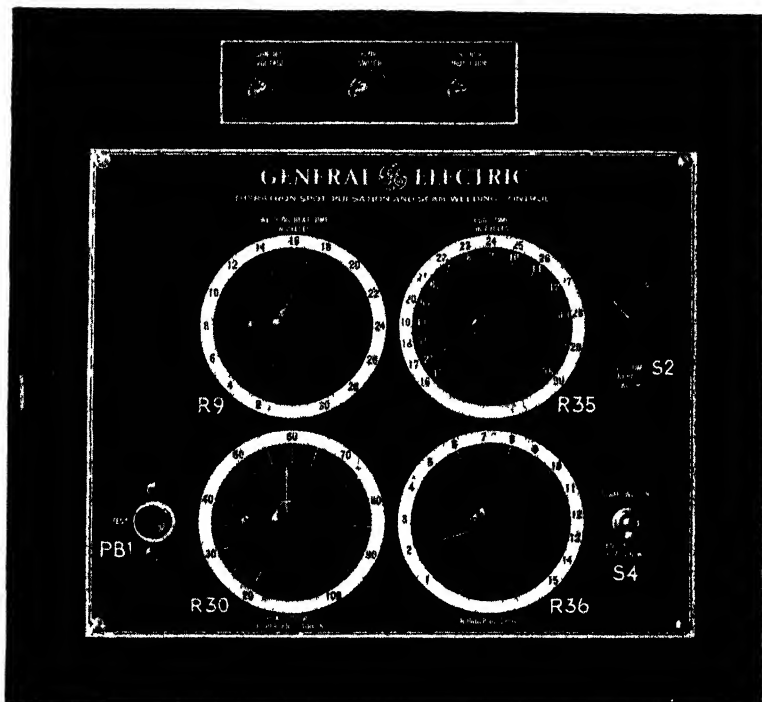

Fig. 24B.—Control station for spot-, pulsation- and seam-welding.

*TR1* are described in Secs. 16-1 to 16-5. The phase-shifted power circuit (tubes 5, 6, 7 and 8) is described in Sec. 20-3, and the phase-shifting control circuit is described in Secs. 19-6 and 19-7. The leading-trailing control circuit (tubes 3 and 4) is described in Sec. 20-2

The d-c supply and safety circuit at the top of Fig. 24C is described in Secs. 16-6 to 16-10. Resistors *R1* to *R7* make a voltage divider,<sup>16-11</sup> and resistors *R37* to *R40* are another voltage divider.<sup>24-9</sup> The voltage ripple of *T4S* and *R54A* is mentioned in the footnote to Sec. 20-2. The lower portion of Fig. 24C is



the timing circuit, not yet described. The portion inside the dotted line controls the operation of the equipment with a spot or pulsation welder, mentioned later.<sup>24-6</sup> The remaining portion is described below, first as it applies to operation as a seam-welding control.

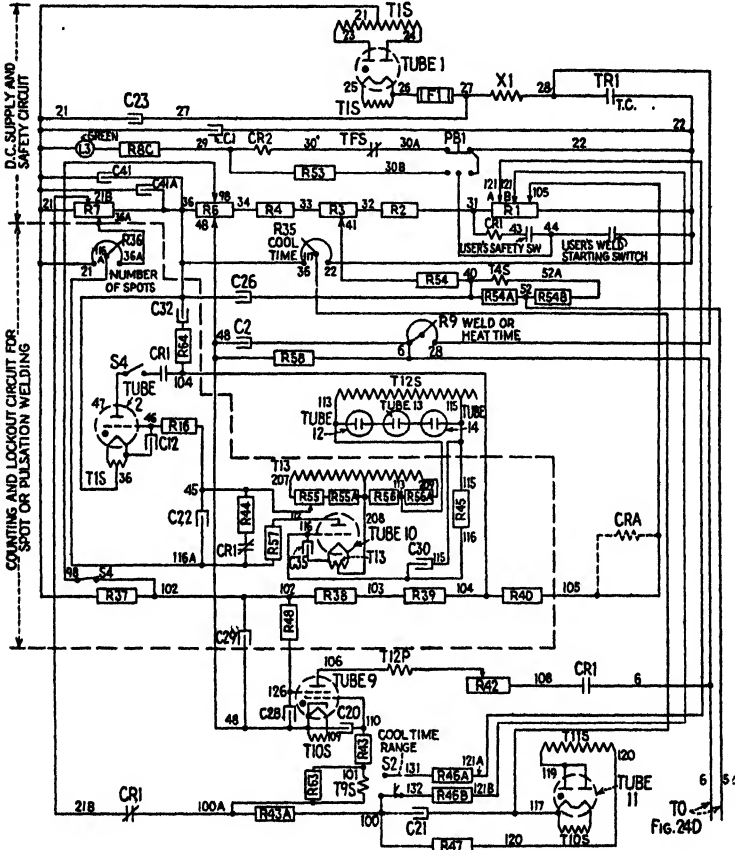

FIG. 24C.—Elementary diagram (timing) of CR7503-C107 control.

The final purpose of all the circuits in Fig. 24C is to control tube 3 in Fig. 24D, so the only electrical connections between these two portions are the two wires that connect to the cathode 6 of tube 3, and through R14 to its grid 53. It is already known that, when tube 3 passes current, this fires tube 4. These tubes pass current through T3P, and the T3S windings then permit

tubes 5 and 6 to fire their ignitron tubes 7 and 8, which pass current to the welder. Each time this welding current is started by tube 3, it flows until tube 3 stops passing current, and this is controlled by the timing circuit connected to the grid and cathode of tube 3.

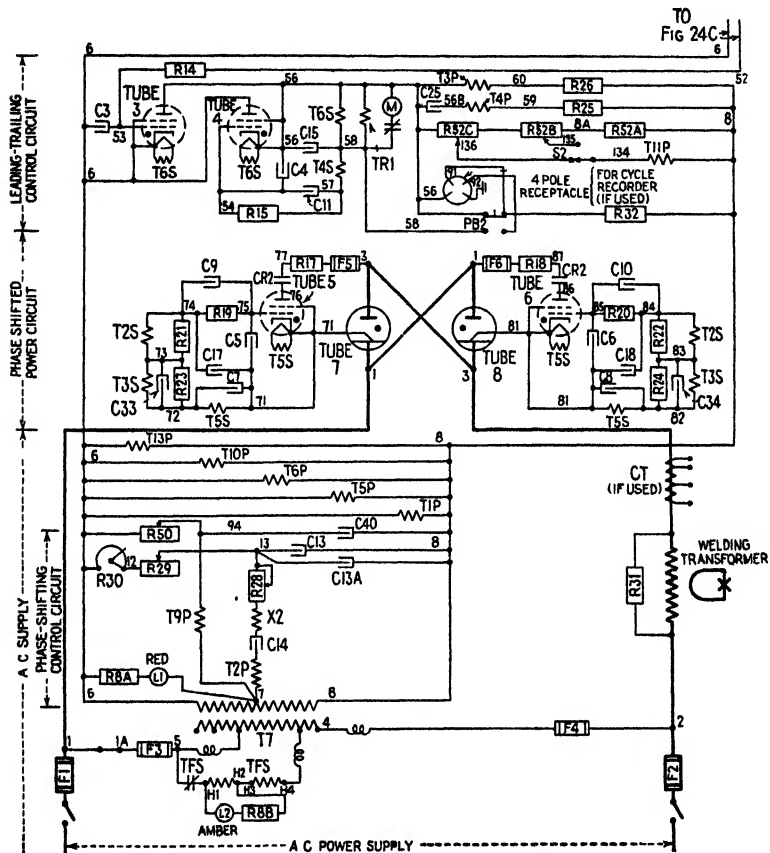

Fig. 24D.—Elementary diagram (power) of CR7503-C107 control.

**24-3. The Spot Length Control.**—The parts of Figs. 24C and 24D that control the time length of each current impulse or spot are shown again in Fig. 24E, which also shows the circuit that controls the cool time between spots. To show these circuits very simply, the less important devices are omitted. Since every weld is made while tube 3 is passing current, notice first

that its grid 53 is connected to point 41 on  $R3$  of the voltage divider; this grid voltage remains unchanged. However, cathode 6 of tube 3 is the point whose voltage is changed to make tube 3 fire. Before the weld is started, the timing capacitor  $C2$  is already fully charged to about 320 volts d.c., between points 28 and 48. No current now flows through  $R9$  and there is no voltage

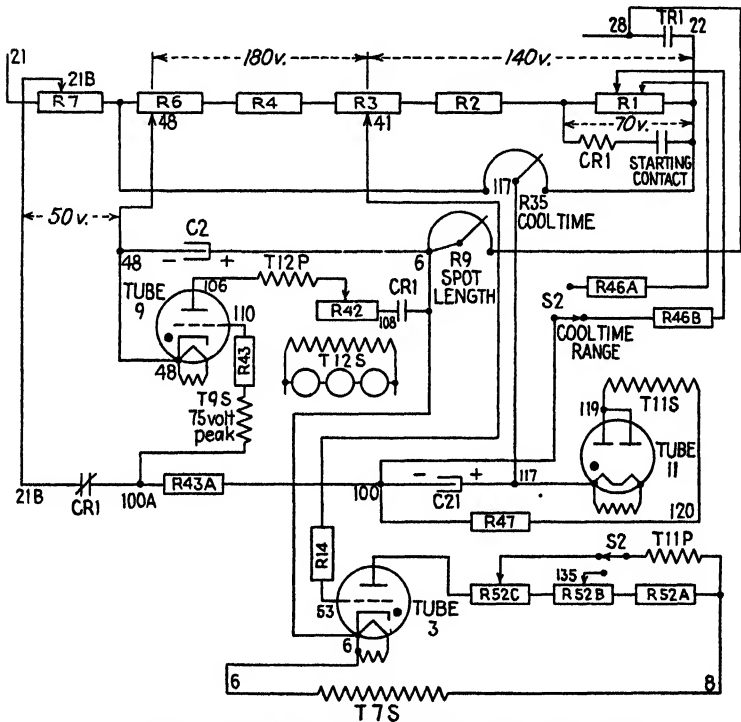

FIG. 24E.—Circuits controlling "heat" and "cool" times.

drop across  $R9$ , so cathode 6 is at the positive potential of points 28 or 22. ( $TR1$  connects 28 and 22 after 5 min warm-up.) Since cathode 6 is more positive than the grid voltage 41, tube 3 does not fire. This condition is shown by the voltages of tube 3 in Fig. 24F. Likewise, before the weld starts, tube 9 is kept from firing because it has no anode voltage ( $CR1$  contact is open; this is similar to operation of tube 2 in Sec. 18-2). The grid of tube 9 at point 100A is about 50 volts more negative than

its cathode 48 because of the voltage difference between slider 21B on R7 and slider 48 on R6. Once each cycle, a 75-volt peak appears in T9S, which overcomes this 50-volt bias and makes tube-9 grid positive. Notice also the complete circuit from slider 21B to 100A, through R43A and C21 to point 117, the slider of R35. By this circuit, C21 has become charged to the voltage difference between 21B and 117. This capacitor C21 holds the voltage at point 100A negative for a short time after

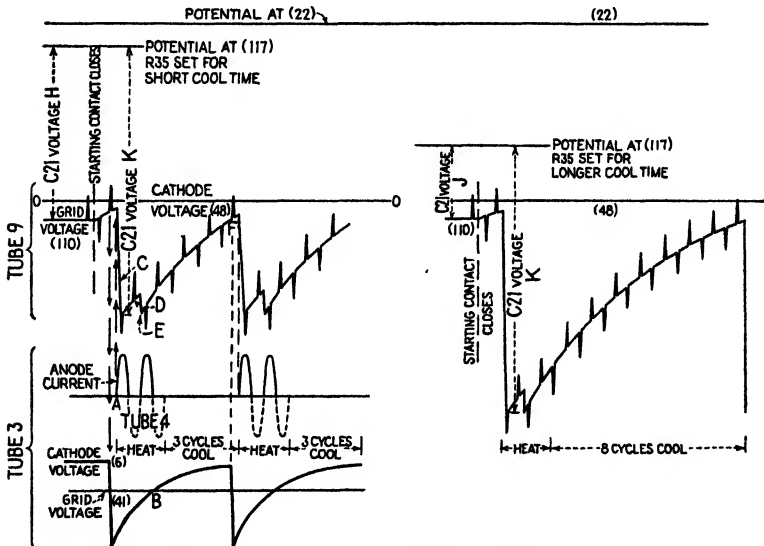

FIG. 24F.—Grid voltage of tube 9, controlling "heat" and "cool" times.

the CR1, normally-closed contact opens between 21B and 100A, when CR1 is picked up as mentioned below.

A welding operation begins with the closing of the starting contact, which picks up relay CR1. The CR1 contact shown below R9 closes the circuit 6-to-108, which applies the voltage of the timing capacitor C2 across the anode-cathode (106-to-48) circuit of tube 9. However, tube 9 does not fire until the next positive peak of T9S voltage appears in the grid circuit of tube 9. When this next T9S peak makes the grid 110 positive, tube 9 fires and permits the voltage of capacitor C2 to force current to flow from C2 to point 6, through CR1 contact, R42, T12P and tube 9 back to 48 and C2. This current discharges C2 very

quickly, making the voltage across *C2* decrease suddenly to zero and making the potential at 6 drop to the potential at 48. Point 6 is the cathode of tube 3, and this now becomes more negative than point 41 (connected through *R14* to the grid of tube 3) so tube 3 fires as soon as its own a-c anode voltage becomes positive, or about  $\frac{1}{4}$  cycle later, as shown at *A* in Fig. 24*F*.

Meanwhile, as *C2* discharges and its voltage decreases, until no voltage remains in the anode circuit of tube 9, the current in tube 9 stops, and its grid regains control to prevent further firing. (See Sec. 24-7 for details, and for the purpose of transformer *T12*.) Immediately *C2* begins to charge again, since it is still connected to points 48 and 28. Since this charging current passes through *R9*, the setting of *R9* controls the speed with which *C2* charges. As *C2* charges, the potential of cathode 6 gradually rises until it becomes more positive than grid potential 41. When *C2* has charged to this point (*B* in Fig. 24*F*) tube 3 cannot start additional half-cycles of current, so the impulse of welding current is ended.

**24-4. Tube 9 Held Off.**—While *C2* is recharging and *CR1* remains energized, anode voltage begins to appear again across tube 9, so tube 9 will fire again unless something is done to prevent the following positive peaks of *T9S* from making the grid of tube 9 positive. Tube 9 is held off or prevented from refiring, as follows: The grid circuit of tube 9 is disconnected from the potential of slider 21*B* when *CR1* is energized. The voltage at 100*A* now depends upon the voltage across *C21*, which decreases only slightly in the next moment. When tube 3 passes current, it not only energizes *T3P* to start the weld, but also energizes *T11P*, as shown in Fig. 24*E*. (Tube 4, not shown, also helps to energize *T11P*, which is a 1-to-1 transformer. *T11S* voltage is equal to *T11P* voltage.) The voltage of *T11S* forces current in one direction through rectifier tube 11, so as to charge *C21* to a larger d-c voltage than it just had. This charging current flows from 119 through tube 11 to *C21*, and returns from 100 through *R47* to 120. The voltage across *C21* increases (at *C* in Fig. 24*F*), making point 100*A* become more negative so quickly that the following peaks of *T9S* are unable to fire tube 9.

**24-5. Control of Cool Time.**—After an impulse of welding current is finished, the length of the cool time, before another

current impulse can start, depends upon capacitor  $C21$  and the time required for it to lose enough of its voltage charge so as to let the grid of tube 9 again be made positive by the peak voltage of  $T9S$ . When  $CR1$  is energized, its normally-closed contact disconnects  $C21$  from slider  $21B$ . Capacitor  $C21$  then starts to discharge by forcing current from its 117 end to  $R35$ , to point 22, to slider on  $R1$ , and back through either  $R46A$  or  $R46B$  and  $S2$  to the 100 end of  $C21$ .

After  $C21$  is charged to a greater voltage (by current through tube 11) at  $C$  in Fig. 24*F*, its voltage then starts to decrease as at  $D$ . However, during every half-cycle when tube 3 fires, tube 11 passes current which recharges  $C21$ , as at  $E$ . When the impulse of welding current ends and tube 3 no longer fires,  $C21$  continues to discharge and its 100 end becomes more positive, as shown by line  $EF$ . The positive peaks of  $T9S$  are gradually raised closer to the 0-0 line until, at  $F$ , one peak makes the grid voltage of tube 9 become positive. This fires tube 9, which starts another impulse of welding current like the one already described.

The length of the cool time is adjusted by the slider of  $R35$  and by the range switch  $S2$ , which Fig. 24*E* shows in the position that gives the longer time range. One contact of  $S2$  now makes  $C21$  discharge through  $R46B$ , which is a greater resistance, decreasing the speed with which  $C21$  discharges. At the same time, the other  $S2$  contact connects  $T11P$  to  $R52C$ , so that nearly the whole control voltage 6-to-8 energizes transformer  $T11$ , so as to charge  $C21$  to a much greater voltage than shown at  $K$  in Fig. 24*F*. This forces the grid voltage of tube 9 to such a negative voltage that as many as 30 cycles pass by before  $C21$  discharges enough to permit tube 9 to fire again. With  $S2$  turned to the shorter time range,  $C21$  discharges more quickly through the smaller resistance  $R46A$ , and  $T11P$  is connected to  $R52B$ , using this lower voltage (135-to-8) to produce less charge on  $C21$ , so that not more than 15 cycles pass by before  $C21$  discharges enough to permit tube 9 to fire again.

For either position of  $S2$ , the cool time is shorter when the 117 slider of  $R35$  is turned closer to the 22 end. In this position,  $C21$  is charged to a large voltage before the starting contact closes, as shown at  $H$  in Fig. 24*F*. When tube 3 fires, the current through tube 11 charges  $C21$  to the voltage shown as  $K$ .  $C21$  quickly discharges back to the voltage of  $H$ , where tube 9 again fires.

However, when slider 117 is turned away from the 22 end,  $C21$  is charged to a low voltage  $J$  before the starting contact closes. The current through tube 11 then charges  $C21$  to the same voltage  $K$  as before, but this now forces the potential of 100 and the grid of tube 9 to become so negative that  $C21$  must discharge more completely, taking longer time, before tube 9 can again fire.

**24-6. Control of Spot or Pulsation Weld.**—When making a spot or pulsation weld,<sup>10-1</sup> the circuits of Fig. 24*E* work the same as already described, but additional circuits are brought into use for the purpose of counting the one or more impulses of current that make the one weld. These additional circuits are shown in Fig. 24*G*, and are placed in operation by throwing switch  $S4$  to the position marked "Spot weld or pulsation weld." In Fig. 24*G* the contacts of  $S4$  are shown in this position.

As described later in detail, each time when tube 9 discharges  $C2$  and begins an impulse of welding current, transformer  $T12$  lets tube 10 pass current into capacitor  $C22$ . After the desired number of these impulses or spots have occurred, as chosen by the setting of the slider of  $R36$ , capacitor  $C22$  becomes charged enough to let tube 2 fire. Tube 2 prevents any additional spots or flow of welding current by making the shield grid 126 of tube 9 so negative that tube 9 cannot fire again. The starting contact must then be opened and closed again before the next pulsation weld can begin. To produce a single spot weld,  $R36$  is turned close to its 36*A* end, so that tube 2 locks out tube 9 after only one impulse.

**24-7. Control Signal for Each Current Impulse.**—Before seeing how the number of current impulses is counted and controlled during the pulsation weld, first see how each impulse of welding current produces a control signal that is unchanged by the length of either the "heat" or "cool" time. As already described, when the starting contact closes in Fig. 24*E*,  $CR1$  closes its 6-to-108 contact so that the voltage of  $C2$  can force current through tube 9, starting at the instant when  $T9S$  produces its next positive voltage peak. This current through tube 9 also passes through  $T12P$  winding, producing a small voltage across it. The secondary winding  $T12S$  is shown connected to tubes 12, 13 and 14, which are small neon glow lamps. These lamps are made so that they do not light or pass current until the  $T12S$  voltage rises to about 150 volts; then they short-circuit  $T12S$ , and this

prevents the voltage across *T12P* from increasing further. As *C2* discharges and the current through tube 9 and *T12P* decreases again, the neon lamps suddenly go out, always at the same definite amount of current.

The voltage produced by *T12S* is a high peak, followed later by a lower peak. It is this high-voltage peak of *T12S*, occurring just once at the start of each flow of welding current, which is used as a control signal in the counting of the desired number of current impulses in the pulsation weld.

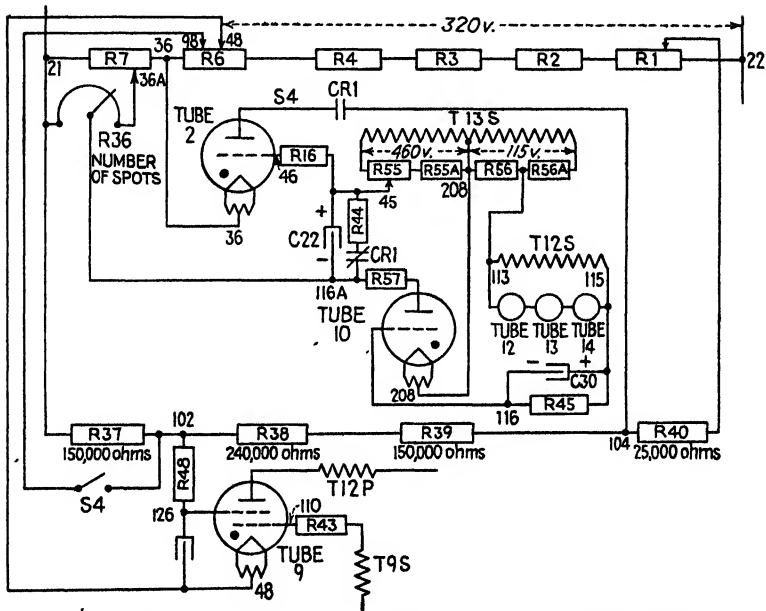

FIG. 24G.—Circuit for counting impulses of spot- or pulsation-weld.

**24-8. The Counting Circuit.**—Each time *T12S* produces its peaked control signal, it lets thyatron tube 10 pass current. In Fig. 24G trace the grid voltage of tube 10 from cathode 208 through *R56*, to 113, across *T12S* to *R45*, and to grid 116. The voltage across *R56* is completely out of phase with the anode voltage of tube 10, producing a negative bias of about 55 volts. This voltage also forces current through *R45*, charging *C30* by grid rectification.<sup>7-18</sup> These voltages keep tube 10 from firing. Each voltage peak of *T12S* forces the grid 116 positive, firing



tube 10 always at the same point on the a-c voltage wave. When tube 10 fires, current flows from slider 45 on *R55* into capacitor *C22*, from point 116A through *R57* and tube 10 to point 208. This current flows for  $\frac{1}{4}$  cycle, and is limited by passing through *R57*; it increases the charge on capacitor *C22* about 5 volts each time when tube 10 fires. When tube 10 has fired 6 times, *C22* is charged to about 30 volts. At the end of each complete weld, *CR1* is deenergized and discharges *C22* through resistor *R44*.

Capacitor *C22* is connected in the grid circuit of thyatron tube 2. Notice that the cathode of tube 2 is connected to point 36 on the voltage divider, while the grid 46 is connected, through *R16* and *C22*, to the slider of *R36*, whose voltage is always more negative than cathode 36. When *R36* slider is touching the 36A end (and *C22* is discharged, as at the beginning of a new weld), the grid 46 is only a few volts more negative than cathode 36. The first time tube 10 fires, its current charges *C22* about 5 volts, which makes grid 46 sufficiently positive to fire tube 2 and prevent further welding-current impulses. Suppose that the slider of *R36* is now turned closer to point 21, so that the grid 46 is made about 40 volts more negative than cathode 36. A pulsation weld is started when *CR1* operates, and each impulse of welding current makes tube 10 pass current once; this increases the voltage of *C22* by 5 volts. After five impulses, when *C22* is charged to 25 volts, grid 46 is still 15 volts more negative than cathode 36. Not until the eighth current impulse has started is *C22* charged to a large enough voltage to equal or overcome the 40-volt bias on the grid of tube 2. By moving the *R36* slider closer to 21, as many as 15 current impulses will occur before *C22* is charged enough to let tube 2 pass current.

**24-9. Ending the Spot or Pulsation Weld.**—When tube 2 passes current, no additional impulse of welding current can start because of the way in which tube 2 controls tube 9. Before tube 2 passes current, notice that the voltage divider (resistors *R37*, *R38*, *R39* and *R40*) is designed so that the potential at point 102 is about the same as the potential at point 48. The shield grid 126 of tube 9 is connected, through protective resistor *R48*, to point 102. As long as this shield grid has nearly the same potential as cathode 48, tube 9 is not affected by the shield grid, but responds only to its control grid 110. Now let tube 2 pass current and see what happens to tube 9. Current through

tube 2 starts from positive point 22, through *R1* slider and *R40* to point 104, through *CR1* contact and *S4* to tube-2 anode, and then to point 36. With this current flowing, point 104 is brought down to nearly the same potential as point 36 (since the voltage drop through tube 2 is only about 15 volts). When the potential at 104 is so greatly decreased, the potential at all points between 104 and 21 is made even more negative. The shield-grid potential at 102 becomes about 60 volts more negative than cathode 48. At such negative potentials the shield grid 126 gets control of tube 9 and prevents passage of anode current, even when the control grid 110 becomes positive. After the impulse just now started, tube 2 prevents tube 9 from further firing, and this ends the group of welding-current impulses, since tube 3 cannot fire to start the other tubes. Tube 9 remains locked out in this way until the starting contact is opened and a *CR1* contact opens\* the anode circuit of tube 2.

When switch *S4* is moved to the "seam-welding" position, this prevents tube 2 from locking out tube 9, and there is no end to the succession of heat and cool periods as long as the starting contact remains closed. One *S4* contact has opened the anode circuit of tube 2, while the other *S4* contact has closed, solidly connecting the shield grid of tube 9 to slider 98 on *R6*, which makes shield grid 126 slightly more negative than cathode 48. In this condition tube 9 is completely controlled by its control grid 110.

**24-10. Sequence Control.**—Although the above equipment controls all current flow during a seam, pulsation or spot weld, the operation of the welder electrodes or rolls must be controlled by other devices. A sequence control,<sup>20-12</sup> if used with this equipment, must include timing of only the squeeze, hold or off times. A relay (*CRA* in Fig. 24C) is added, which operates at the beginning of the last weld impulse and lets the hold time start at the end of that impulse.

With such a sequence control, the operator's foot switch energizes the solenoid valve to bring the welder electrodes

\* In Fig. 24C a capacitor *C32* is shown connected between points 104 and 36. When *CR1* contact opens the anode circuit of tube 2, capacitor *C32* charges slowly, preventing the potential of point 104 from rising so suddenly as to let tube 9 give an undesired operation, before *CR1* contact can open the anode circuit of tube 9.

together, and also starts the squeeze timer. The squeeze timer (or a firing or pressure switch on the welder) closes the starting contact, which lets the synchronous equipment start the spot or pulsation weld. When the last impulse of current flows, tube 2 locks out tube 9, as already described. This current through tube 2 also energizes the *CRA* relay, whose contact starts the hold timer on the sequence control at the end of the weld.

## CHAPTER 25

### WELDER CONTROLS USED WITH SERIES CAPACITORS

As larger resistance welders are installed in greater numbers, the problem of supplying power to these welder loads becomes more serious. One way to decrease the load required by large a-c welders and their effect on the power-supply system is to use series capacitors.\* Problems of power supply for welders have been discussed in Chap. 13, including the use of capacitors.<sup>13-11 13-12</sup>

**25-1. Welder Power Circuit Using Series Capacitor.**— The circuit of Fig. 25A shows that the welding machine and control equipment are connected to the line as usual, except that the series capacitor is connected between one side of the power supply and one terminal of the welding transformer. By the use of such a capacitor equipment, a welder that usually takes a load of 1000 kva or 2500 amp from the power line is often corrected so that it takes only 300 kva or 700 amp from the same power line, while making the same weld. During the weld, the same line current passes through the control, the welding transformer primary and the capacitor, but the voltage across each of these parts is not the same, and is usually much greater than line voltage. As shown later, the whole equipment may operate from a feeder which supplies 440 volts at the line switch, yet the voltage across the welding transformer may be about 1400 volts, with nearly this much voltage across the series capacitor also. These higher voltages are produced by the series capacitor, as will be shown later, but they appear only within the control enclosure and capacitor enclosure and at the primary terminals of the welding transformer or autotransformer. These higher voltages cause no danger to the welder operator.

To work properly and safely at these voltages, the control equipment must be specially built for this service; it is described

\* For complete discussion, see L. G. Levoy, Jr., Power Factor Correction of Resistance Welding Machines by Series Capacitors, in *Electrical Engineering*, December Supplement, 1940, p. 1002.

in Sec. 25-4. The welding transformer is built to work directly at the higher voltage, or the voltage is reduced by an auto-transformer down to the voltage of a standard welding transformer. The capacitor equipment itself is built in a separate enclosure, together with its own protective features. Usually from 5 to 20 separate capacitor units or cans are mounted inside the enclosure, each unit being rated from 10 to several hundred  $\mu$  f, but built as described in Sec. 7-12.

Most series capacitors are installed along with new welders and new controls, all carefully selected to work together properly. It is not generally practical to add capacitors to a welder already in operation unless new control equipment and welding transformer (or autotransformer) are also furnished.

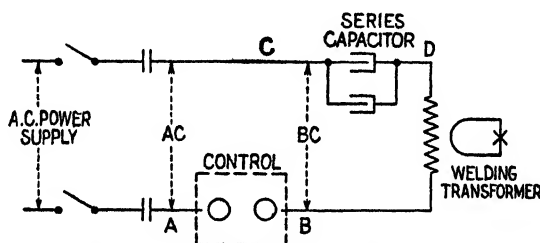

FIG. 25A.—Connection of series capacitor with welder and control.

A welder with series capacitors can be controlled by a magnetic contactor or Ignitron Contactor or Weld-O-Trol, but such contactors must be selected or built to work safely at the higher voltages produced. It is not necessary to use synchronous-timing control just because series capacitors are used. The series capacitors tend to prevent serious transient currents, so nonsynchronous controls work better with series capacitors than without them.

Series capacitors are usually selected large enough to correct the largest expected load of the welder to 100 per cent power factor. As shown later,<sup>25-9</sup> a more costly capacitor is needed for correction to a *lagging* power factor.

**25-2. Voltages in the Circuit during the Weld.**—When all switches are first closed, in Fig. 25A, so that only the ignitron tubes prevent the flow of welder current, there is no charge on the capacitors, and no voltage across them. Only line voltage appears across the ignitrons or in any part of the circuit. The

first time current flows in the circuit, it almost immediately charges the capacitors, at the same time producing voltage across the capacitors and producing more than line voltage across the welding transformer. Notice that the ignitrons do not connect the capacitors right across line voltage (as happens when shunt capacitors are placed in service), but that the capacitors and the welding transformer are in series with each other, and their combined voltages equal line voltage.\*

For use with a welding transformer whose measured load is 2500 amp at 30 per cent power factor, Fig. 25B shows the voltages in the circuit when just the right number of series capacitors is used to correct or bring this total load to unity, or 100 per cent power factor. The load current is now decreased to

$$2500 \times 0.30 = 750 \text{ amp,}$$

and this same 750 amp a.c. flows through the welding transformer, through the series capacitor and through the control-equipment ignitron tubes. At 100 per cent power factor, this

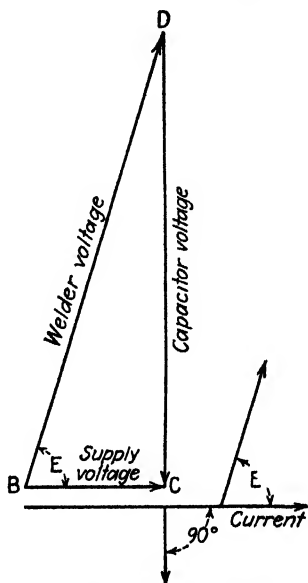

FIG. 25B.--Vector diagram of capacitor, welder and supply voltages.

\* If two resistors are connected like this, in series, the voltage across each resistor is less than line voltage. A 100-ohm and a 300-ohm resistor, connected in series across 400 volts, will have 100 volts drop across the 100-ohm resistor and 300 volts drop across the other. These two voltages add together: 100 volts + 300 volts = 400 volts. Similarly, if two capacitors are connected in series across 400 volts, the voltage across each capacitor is less than 400 volts. A 100-ohm capacitor and a 300-ohm capacitor divide the total voltage in the same way, 100 volts across the first, 300 volts across the second. (At 60 cycles, capacitor ohms =  $\frac{1,000,000}{2\pi \times 60 \times \mu f} = \frac{2660}{\mu f}$ )

However, when a capacitor is connected in series with a resistor or a transformer, the voltages cannot be added in this easy way, since the voltage across the capacitor is 90 degrees behind its current and cannot be added to resistor voltage (which is in phase with its current) except by using a vector diagram.

current is in phase with the line voltage, and is therefore shown by an arrow in the same direction as the line voltage. When this 750-amp current flows through the capacitor, it produces voltage across the capacitor. This voltage is shown as arrow  $DC$ , in a direction 90 degrees behind the current. The voltage across the welding transformer must be of the right size to complete the triangle  $BCD$ . The welder voltage arrow  $BD$  must have such a direction that the supply voltage  $BC$  lags behind it, so that the angle between the two arrows is equal to the power-factor angle  $E$  of the welding-machine load. (If the welder power factor is 30 per cent, then the length of  $BC$  is 30 per cent of the length of  $BD$ .  $DC$  must be vertical.) Notice in Fig. 25A that the voltage  $BC$  is not the same as line voltage  $AC$ , but is about 15 volts less than line voltage because of the voltage drop across the ignitron tubes while they are passing current.

From the triangle of Fig. 25B, if a welder operates at 30 per cent power factor from a 440-volt line, with the right number of series capacitors to correct it to 100 per cent power factor, then voltage  $BC = 440 - 15 = 425$  volts; voltage  $BD$  across the welding transformer primary  $= 425/0.30 = 1420$  volts. By measuring the length of arrow  $DC$  or calculating ( $DC = 1420 \text{ volts} \times \sin E$ ), the voltage across the capacitor is found to be about 1360 volts.\*

The voltages across the welding transformer and across the capacitors are larger when used with a low-power-factor welder than when used with a higher power-factor welder. It is necessary to know the power factor of the welding load quite accurately before the proper series capacitors are selected and installed.

\* In comparison, if the welder is measured and takes a load of 2500 amp at 40 per cent power factor, different series capacitors are now needed to correct to 100 per cent power factor, and the line current is reduced to 1000 amp. On a 440-volt line,  $BC$  is still 425 volts, but voltage  $BD$  across the welding-transformer primary is now  $425/0.40 = 1060$  volts, and the capacitor voltage is about 970 volts.

With a measured welder load of 2500 amp at 60 per cent power factor, the proper series capacitors may correct to 100 per cent power factor, reducing the line current to 1500 amp. On a 440-volt line,  $BC = 425$  volts, and  $BD$  welder voltage is  $425/0.60 = 709$  volts; capacitor voltage is about 570 volts.

On a 220-volt line, the welder and capacitor voltages are approximately one-half of the values given above.

**25-3. Circuit Voltages between Welds.**—After the first impulse of welding current has charged the capacitors and has increased the voltages in the circuit, the capacitors will hold their voltage charge for many seconds. During the usual time between separate welding operations, the capacitors remain charged. With no current flowing, there is no voltage drop across the welding transformer, so, in Fig. 25A, point *B* is at the same potential as point *D*, and these points are both at greater voltage than point *C* because of the voltage remaining on the capacitor. Between welds, the ignitrons have across them the voltage difference between *B* and *A*, and this amounts to the whole line voltage added to the capacitor voltage. Ignitrons or other controls must be able to operate safely at this total voltage,\* which may be close to 2000 volts.

The capacitors may gradually lose their charge and voltage if left for long periods because of current leakage through the cooling water of the ignitrons. When the welder and its control are shut down, or power fails, a separate contactor closes a normally-closed circuit which discharges the capacitors quickly.

**25-4. Synchronous Controls Used with Capacitors.**—Series capacitors do not change or greatly affect the weld itself, and they may be used with spot or pulsation welders or with seam welders. The same standard controls (already described in Chaps. 15, 19, 20, 23 and 24) could be used with series capacitors except that they are not arranged for operation at the higher voltages and the grid circuits of their firing thyatron tubes are not suitable for the different voltage phase relations produced by the capacitors. However, synchronous controls are available which are designed for use with series capacitors and which may also be used with uncorrected a-c welders operating directly from 2300-volt supply feeders. Three styles of these high-voltage controls (CR7503-A106, -B106 or -C106) correspond to the standard low-voltage controls for spot welders (Fig. 20A), seam welders (Fig. 23A) or combined spot, seam and pulsation welders (Fig. 24A). The high-voltage spot-welder control is shown in Fig. 25C. As would be expected, the main differences between the high-voltage and the low-voltage controls are found in the

\* When ignitrons are used at these higher voltages, the permissible load current and the averaging time are decreased considerably from the values given in Fig. 5D.



mounting and arrangement of the ignitrons and in the circuits of the tubes that fire the ignitrons.

**25-5. High-voltage Seam-welding Control (CR7503-B106).**— This seam-welder control is much like the low-voltage equip-

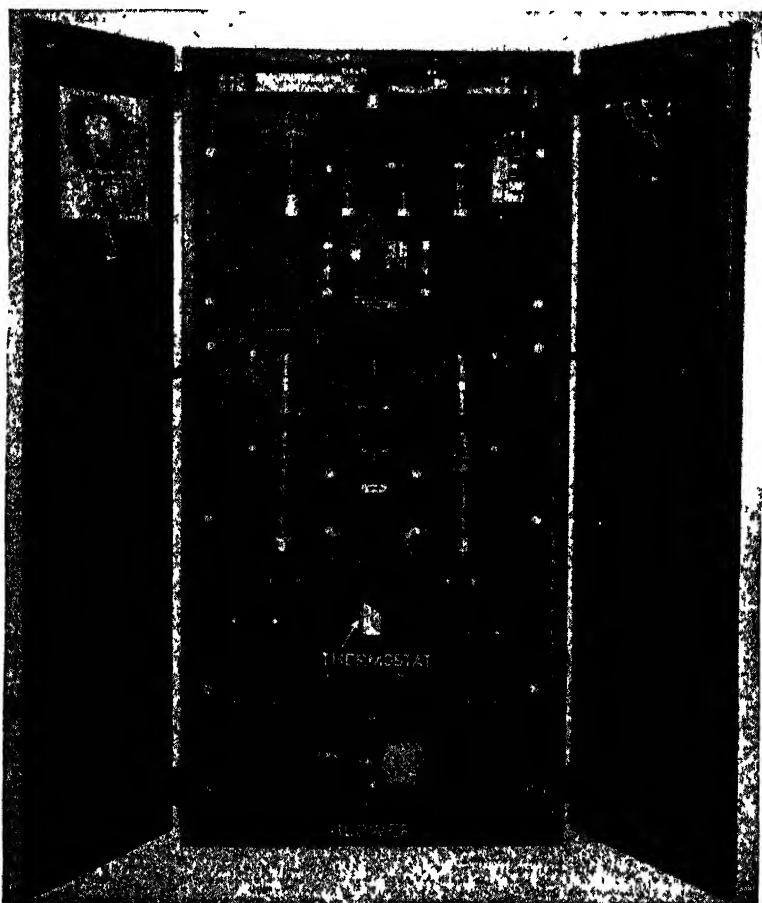

Fig. 25C.—Synchronous spot-welding control used with series capacitors or high-voltage supply. CR7503-A106.

ment.<sup>25-5</sup> The main differences, as shown on the elementary diagram Fig. 25D, are as follows:

1. The ignitrons are fired by a pair of FG-105 thyratrons, used because they work better at higher voltages. This thyatron

grid circuit requires more control power than the chain contact should carry, so a pair of FG-95 tubes, 3 and 4, is added to fire the FG-105 tubes, 5 and 6.

2. Two GE-83 rectifiers, tubes 9 and 10, are added to produce d-c bias voltages in the grid circuits of the FG-105 thyratrons.

3. Devices on the lower section of the control panel are spaced farther apart for operation at higher voltages. A high-voltage contactor *CR3* is added, to open safely the anode circuits of the FG-105 firing thyratrons. In these circuits the 3-amp fuses are designed for 2300-volt service, and 50-ohm resistors are used with several taps for operation at various voltages.

4. Safety interlocks are furnished on front and rear doors and also on the capacitor enclosure to permit use with a contactor or circuit breaker if desired. These disconnect the power when the doors are opened.

5. A blower is arranged to circulate air up around the tubes in the high-voltage circuits, to help cool the tubes and give better operation at higher voltages.

6. The discharge resistor across the welding-transformer primary has a number of thyrite resistors connected in series.

The diagram of the low-voltage seam-welder control (Fig. 23C) should be compared with Fig. 25D, the elementary diagram of the seam-welder control used with series capacitors. It is seen that the same motor-driven timing chain<sup>23-5</sup> is used in Fig. 25D. When metal buttons on the chain complete the circuit through *T4P*, the two *T4S* windings fire tubes 3 and 4. As shown below, this then fires tubes 5 and 6, causing tubes 7 and 8 to pass current to the welding transformer.

Tubes 3 and 4 are connected back to back so that, when they both fire, full-wave current flows in the circuit from terminal 6 of the control transformer *T7* through the tubes to point 56, through *CR2* contact and *T3P* and *R15*, to terminal 8 of *T7*. Tubes 3 and 4 have anode voltage from the 460-volt control power. In the grid circuits of tubes 3 and 4, the 115-volt *T6S* windings are out of phase with the anode voltage and prevent the tubes from firing. (As explained in Sec. 17-7, *T6S* also charges capacitors *C9* and *C21* so as to keep a negative bias on the grids of tubes 3 and 4.) However, when current passes through the metal chain buttons and the primary of transformer *T4*, each *T4S* winding then produces 300 volts a.c., and this voltage is

in phase with the tube-anode voltage. This 300 volts is greater than the hold-off voltage of *T6S*, so the grids are made positive and permit tubes 3 and 4 to fire. This current passing through

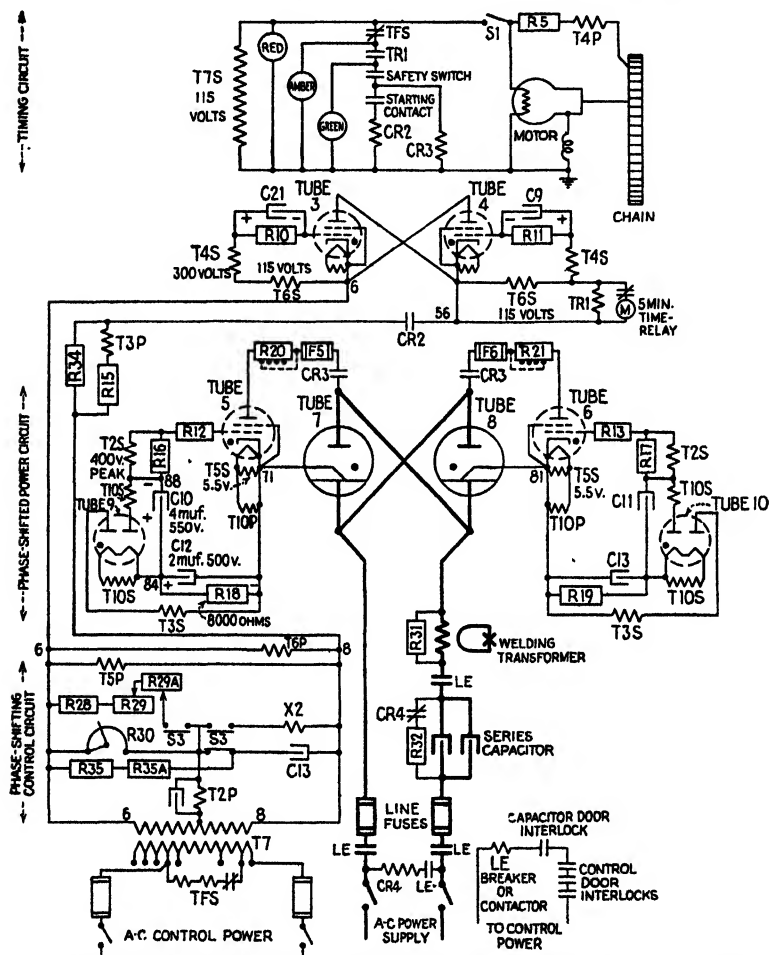

FIG. 25D.—Elementary diagram of seam-welding control (CR7503-B106) with series capacitors.

tubes 3 and 4 energizes *T3P*, whose secondary windings turn on tubes 5 and 6, as shown in the next section.

**25-6. Phase-shifted Power Circuit with Rectified Grid Voltages.**—It is seen in Fig. 25D that thyatron tube 5 fires ignitron

tube 7, and tube 6 fires tube 8. The grid circuit of tube 5 is arranged the same as the grid circuit of tube 6.

To understand the grid circuit of tube 5, notice that this circuit starts with cathode 71, then passes across the charged capacitor  $C12$ , then across charged capacitor  $C10$ , then through  $R16$  and  $R12$ , to the control grid of tube 5. Whereas previous phase-shifted power circuits<sup>20-3</sup> like Fig. 20C used three transformer voltages to control the thyratrons, the tube-5 circuit of Fig. 25D includes tube 9 to rectify two of these transformer voltages, so as to charge capacitors  $C10$  and  $C12$ . The third transformer winding  $T2S$  produces the turn-on peak voltage (400-volt peak) which fires tube 5. The voltage across  $C10$  is the hold-off voltage to prevent tube 5 from firing. To charge  $C10$ , the transformer winding  $T10S$  supplies about 400 volts a.c., which forces current in one direction through one anode of tube 9, to cathode 84, upward into  $C10$ , to 88 and back to  $T10S$ . This current charges  $C10$  so that it is negative on the side toward the grid of tube 5. (Notice that  $T10P$  is connected across the 5.5-volt winding of  $T5S$ . Transformer  $T5$  is continuously energized, receiving its power from  $T7$ . The secondary winding  $T5S$  not only heats the filament of tube 5 but also supplies power into  $T10P$ , reappearing as a higher voltage at  $T10S$ . This arrangement makes it possible to use a  $T10$  transformer whose windings are insulated for lower voltage. If  $T10$  was energized directly from  $T7$ , the windings of  $T10$  would have larger voltages between them, requiring a larger transformer like  $T5$ .) This voltage across  $C10$  is about 550 volts d.c. continuously, as shown in Fig. 25E, and holds the tube-5 grid at a voltage so far below the 0-0 line that not even the 400-volt peak of  $T2S$  can reach up to the 0-0 line and fire tube 5. This is the condition before the start of a weld, or when tube 3 is not firing.

To make a weld, tubes 3 and 4 are made to pass current through  $T3P$ . (Tube 3 passes the half-cycle that can make tube 5 fire; tube 4 similarly controls tube 6.) The  $T3S$  winding then produces about 365 volts a.c., which forces current in one direction through the left-hand anode of rectifier tube 9. This current charges capacitor  $C12$  to about 500 volts d.c. (See footnote to Sec. 7-14.) Notice that  $C12$  becomes charged during the half-cycle before tube 5 can fire. To do this, the a-c anode voltage of tubes 3 and 4 has been reversed, so that the chain button fires

tube 3 a half-cycle before tube 5 can fire. Also notice that the positive side of *C12* is toward the grid of tube 5, so that the voltage of *C12* opposes the voltage of *C10*. When both *C12* and *C10* are charged, the 500 volts of *C12* overcomes most of the 550 volts of *C10*, reducing the negative bias on tube-5 grid to as little as 50 volts. In this condition, the 400-volt peak of *T2S* easily makes the grid positive (above the 0-0 line), so tube 5 is fired by *T2S* during each cycle when *T3S* has charged *C12*. *C12* loses its voltage rapidly by discharging through *R18* (8000 ohms). When a black button on the timing chain prevents tube 3 from passing current through *T3P*, then *C12* is not charged during

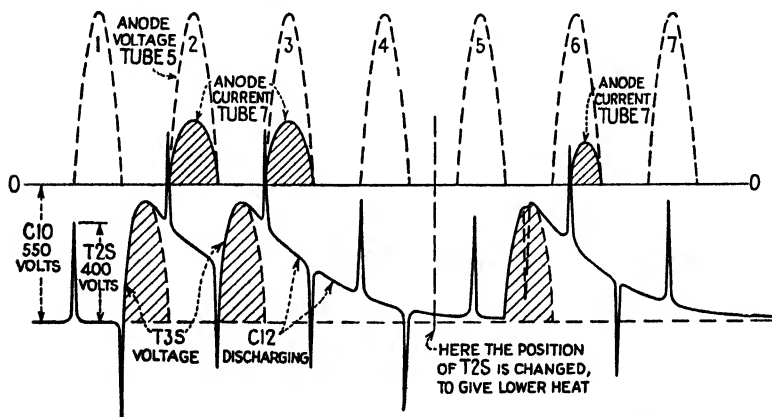

FIG. 25E.—Changes of grid voltage of firing thyratrons.

that cycle. The voltage across *C12* has already decreased so much that the next peak of *T2S* cannot reach up to the 0-0 line, so tube 5 does not fire.

In Fig. 25E tube 5 does not fire during the 1st, 4th, 5th or 7th cycles, but fires at 100 per cent heat during the 2nd and 3rd cycles and at reduced heat during the 6th cycle.

The phase-shifting circuit that controls the position of the *T2S* peaks (as shown in Fig. 25D, above transformer *T7*) gives double-range heat adjustment (described in Sec. 20-8 and Fig. 20M). For use with most series-capacitor equipments, this heat-adjusting circuit is able to advance the position of the *T2S* peaks so that they occur at the start of the voltage wave, producing 100 per cent heat at 100 per cent power factor.

**25-7. Connection of Series Capacitors.**—As shown in Fig. 25D, the series capacitors are connected between the welding transformer and one side of the power supply. For safety, a line circuit breaker or contactor is recommended so that the capacitor can be automatically disconnected from the rest of the control equipment whenever any door interlock is opened. A discharge contactor *CR4* is connected so that, whenever the line switch or contactor *LE* is opened, the *CR4* contact discharges the series capacitor through *R32*. The capacitor units or cans do not contain internal discharge resistors. Except for this, they are the same as shunt capacitors of the same voltage rating.

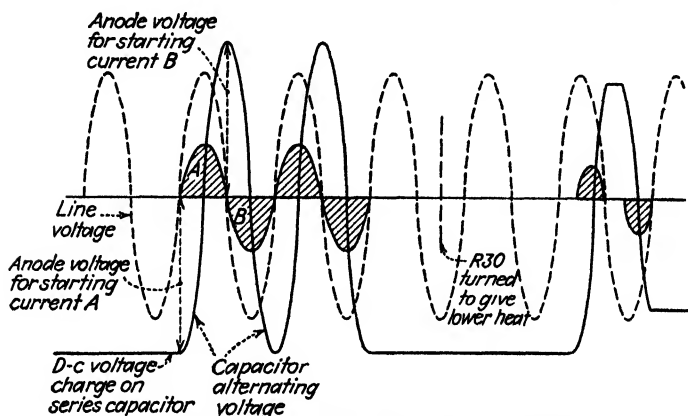

FIG. 25F.—Changes of voltage across series capacitor.

**25-8. High-voltage Spot-welder Control (CR7503-A106).**—The similar spot-welder control shown in Fig. 25C, arranged for use with series capacitors, uses the same phase-shifted power circuit and double-range phase-shifting control as shown in Fig. 25D. The synchronous timing circuit is like Fig. 18D, described in Sec. 18-6. The control circuit of tubes 3 and 4 is like Fig. 20B, described in Sec. 20-2.

**25-9. Operating Welders with Series Capacitors.**—In order to withstand safely the increased voltages caused by series capacitors, it is necessary to use higher-voltage cable (such as 2300-volt cable) for power connections between the capacitor and the welder and control equipment. Place the capacitors close to the welder so as to decrease the length of this high-voltage cable.

Controls previously used with the welder without capacitors are probably not suited for the higher voltages caused by the capacitors, and must usually be replaced.

In Fig. 25*F* the voltage across the series capacitors is shown during the same welds as in Fig. 25*E*. The capacitor voltage alternates while a.c. flows to the welder, and then holds its d-c charge between welds. Notice that the d-c voltage of the charged capacitor becomes the anode voltage available for starting current flow through the ignitrons at the beginning of each half-cycle.

When the capacitors have no charge, as when the equipment is started each morning, the tubes may not fire if the heat control is set at a high value. If so, turn the heat dial to a lower setting, and pass welding current into a piece of scrap metal. This charges the capacitors so that the tubes will then fire at full heat. Sometimes series capacitors are precharged by a special additional circuit in order to prevent this difficulty or to give more consistent results on very short welds.

When series capacitors are used, the welder should not be energized with electrodes shorted. The welder load, corrected by series capacitors, is limited mainly by the resistance in the secondary circuit. With shorted electrodes, this resistance is decreased so that greater line current flows, causing higher voltages across the capacitors and welding transformer. A protective overvoltage device is often used to prevent damage from these occasional higher voltages. A seam welder with capacitors should not permit its rolls to run off the work, so that the rolls touch together.

When the welder load current is corrected close to 100 per cent power factor by using series capacitors, the welder heat is not so greatly affected by different amounts of magnetic material placed in the throat of the welding machine. However, changes in the resistance of the work more noticeably affect the heat of the weld. For example, when the welder is set for welding two pieces of steel, the substitution of two aluminum pieces of the same thickness will cause considerable increase in the secondary-current flow, but this is desirable since greater current is needed to weld this lower resistance material.

When series capacitors are used, any change in resistance caused by dirt or poor contact in the welder dies has a greater effect on the weld heat than it has in a welder without capacitors.

Therefore it is more important to keep clean all contact surfaces of dies and other parts of the low-voltage, or secondary, circuit.

With series capacitors, a change of tap connection to the welder transformer produces much greater change in weld heat than is usually obtained without capacitors. For example, if an ordinary welder operates so that a 20 per cent increase in primary turns causes about 20 per cent decrease in secondary current, then the addition of series capacitors may change the welder operation so that 20 per cent increase in primary turns now causes as much as 50 per cent decrease in secondary current. Therefore, welding transformers specially designed for use with capacitors must have taps giving smaller percentage changes, or else phase-shifting heat control is needed in the synchronous equipment.

Those who have had experience with shunt capacitors (such as capacitors connected continuously and directly across power feeders to improve plant power-factor conditions) may find the operation of series capacitors somewhat confusing, since series capacitors seem to operate in ways opposite to usual shunt-capacitor operation. Using shunt capacitors, all parts of the circuits have the same *voltage*, so a vector diagram shows the relation between the different currents. With series capacitors, all parts of the main circuit carry the same *current*, so the vector diagram shows the relation between the different *voltages*. The following examples show what operation may be expected where series capacitors are used.

If 10 series capacitor units or cans improve a 1000-kva welder load to unity or 100 per cent power factor, then 11 or more of these units are needed to improve *only to lagging* power factor. Fewer than 10 of these units will cause the welder to operate at *leading* power factor.

As shown in Fig. 25G, the welder current flowing through 10 capacitors produces the voltage  $DC$ . This voltage =  $I$  (current)  $\times R$  (capacitor ohms). Capacitor ohms =  $2660/\mu f$  (see Sec. 25-2, footnote). An increase in the number of capacitor units increases the microfarads, thereby decreasing the capacitor ohms and decreasing the voltage drop caused by the same current. This smaller voltage drop  $EF$  is not sufficient to correct the whole reactive voltage of the welding transformer. Therefore the supply voltage takes the position  $BF$ , so that the current  $I$  lags behind the voltage and the circuit operates at lagging power factor. However, when less than 10 capacitors are used, the decrease in microfarads increases the capacitor ohms and



increases the voltage drop across the capacitors. This voltage  $GH$  is now more than sufficient to correct the reactive voltage of the welding transformer, so the supply voltage takes position  $BH$ . Current  $I$  leads this voltage and the circuit now operates at leading power factor. This voltage  $GH$  may be found to be greater than the rated voltage of the capacitors.

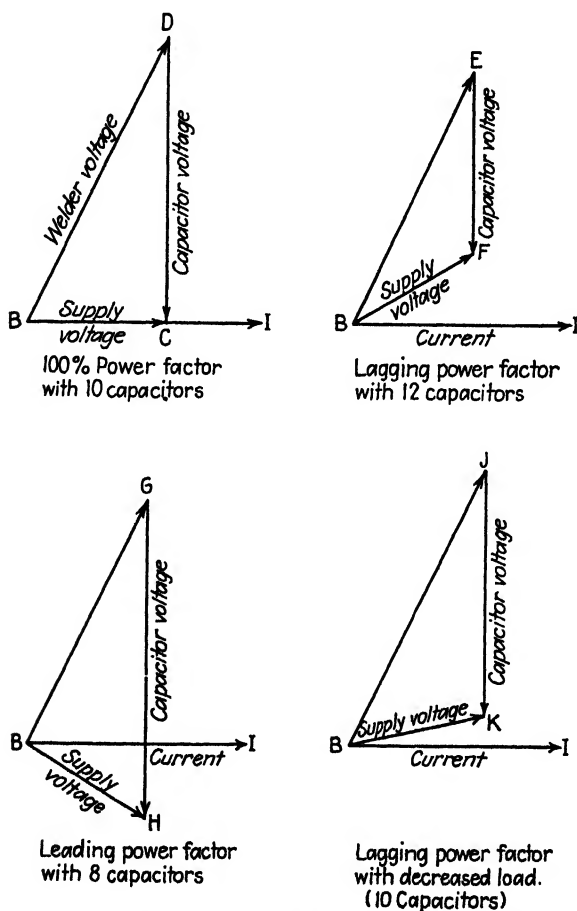

FIG. 25G.—Effect of capacitors and load on power factor.

If the 1000-kva load above is now decreased to 900 kva, as by changing transformer taps, the 10 capacitors make the circuit operate at more lagging power factor. If a higher tap increases the load to 1100 kva, the circuit operates at more leading power factor.

Since now the number of capacitors units is not changed, there is no change in microfarads or capacitor ohms. However, the decreased load requires less current, producing smaller voltage drop across the capacitors at  $JK$ . The current  $I$  lags the supply voltage  $BK$ , so the circuit operates at lagging power factor.

In Fig. 25G, notice that the welder voltage is greatest at  $BD$ , when the supply voltage is in phase with the current. When the supply voltage either lags or leads the current, as at  $BF$ ,  $BH$  or  $BK$ , the resulting welder voltage is decreased, as  $BE$  or  $BG$ .

As shown above, fewer capacitors are needed to improve to unity or leading power factor than are required to improve to lagging power factors. When the welder, with series capacitors, is controlled by a magnetic contactor or ignitron contactor, the circuit may operate at leading power factor. However, the heat-control circuits of most synchronous equipments will not give proper adjustment at leading power factors, so it is necessary to use enough capacitors to correct the circuit to unity or lagging power factors when the synchronous control is carrying the heaviest load (with greatest throat depth) that the welder must supply.

## PART III

# ENERGY-STORAGE WELDING

### CHAPTER 26

#### WELDING WITH STORED ENERGY

All the resistance welders discussed this far have operated directly from the a-c power supply, so that alternating current flows in the windings of the welding transformer. The energy that makes the weld is taken from the supply line at that same instant. Resistance welders are now being used which work with electrical energy that is first stored in capacitors or reactors and then is discharged through the welding transformer and into its low-voltage circuit, to produce the weld. The weld is made by current which is neither a.c. nor d.c., but which is a changing current that increases to its full amount only once for each weld, and then gradually decreases to zero.

**26-1. Purpose of Energy-storage Welding.**—Because of the shape of the welding current wave that can be obtained by stored energy, or because of the short time of current flow, some materials seem to be welded better or more easily, with longer life of electrodes. Welders using stored energy are widely used in welding aluminum alloys, as in aircraft parts. The consistent welding of such parts is partly due to the careful control of electrode pressures, as obtained with most welding machines using stored energy.

A perhaps better known advantage is that the energy for the weld can be stored slowly, so that much smaller current is taken from the a-c power line. For example, the energy-storage welding of two pieces of metal may take 200 amp from a 220-volt power line for  $\frac{1}{2}$  sec. To make this same weld with the usual a-c welder requires as much as 1000 amp current from the same power supply, but for less than  $\frac{1}{10}$  sec. The a-c welder uses single-phase power, taking its large current from only two cables.

Most large energy-storage welders use three-phase a-c power supply, so that the current load is divided among three cables. As these comparisons indicate, the stored-energy welder does not need such a large power supply and such large feeder cables as the usual a-c welder, and may often work in a small plant far from a power substation, making welds that cannot be made in that same plant by the usual a-c welder. The higher first cost of the stored-energy welding equipment is often offset by the lower cost of the necessary power feeder.

Although between  $\frac{1}{4}$  sec and 1 sec is needed to store energy for each weld, the number of welds per minute is large enough for most welding of aircraft parts. However, for more rapid welding of steel parts, as with gun and spot welders in automotive plants, the usual a-c welder is still preferred.

Welders using stored energy are not affected by voltage changes in the a-c power supply, since the controls are set to store the same desired amount of energy whether the supply voltage is low or high at that time.

**26-2. Examples of Energy Storage.**—Thinking back to the days before World War II, there are two ways to pay cash for a \$1000 automobile. A worker may save \$10 each week from his earnings and be able to pay for the car in 2 years, even though he earns less than \$60 per week. But another man, wishing to pay \$1000 without saving his money or getting a loan, must have an income of about \$1000 a month in order to make such payment. Either man can get a \$1000 car, but the method of saving or storing makes the purchase possible for the one with the smaller supply line, or pay check. Only a big income can make such a payment without saving for it. Likewise, a large power supply is needed to furnish the large current load of the usual a-c welder, but the ordinary power supply of a small plant can furnish the energy for making the same welds if the energy is stored gradually over a longer time.

Suppose that a large amount of water is needed, all at once, to flush dirt out of a large pan every few minutes. If this is done in a plant where the water pipes are big enough to supply this large flow of water, then a valve is opened and water flows directly from the water line into the pan. However, if the water pipes are small, water cannot flow from the pipe fast enough to clean the pan. This smaller water flow can still be used to fill a storage

tank overhead, perhaps requiring a minute to do so. A large valve then empties the water from the tank directly into the pan in just a few seconds, flushing the pan clean. By slowly storing water in the tank, the small pipe is made to do the same job as a big pipe, although not so often.

To save the money for the \$1000 car, \$10 goes *into* the bank or sock each week. If the payday deposit is withdrawn several days later, there is no gradual increase in the money saved. Money must move in only one direction—*into* the bank. Notice also that the water always flows *into* the tank while it is being stored to flush the pan. For the same reason, electricity must flow in just one direction while it is storing energy. Since alternating current (a.c.) changes direction so often, a.c. cannot be used for storing energy for longer than a half-cycle. Instead, direct current must be used for storing the energy for welding. Therefore a necessary part of any kind of energy-storage welding equipment is a rectifier to change the a-c power supply into direct current, which can store energy gradually for several seconds if desired.

**26-3. Types of Energy-storage Welders and Controls.**—A welding machine for use with energy storage may be quite different from the usual a-c welder, but both kinds are made by the same manufacturers. The electric control equipments used with these energy-storage welders are divided into two types. Those which store the electric energy in capacitors (static condensers) include the Taylor-Winfield Hi-Wave Control and the Raytheon, General Electric, Westinghouse and Weltronic controls. The other type is represented by the Sciaky welding equipment, which stores energy in reactors or in the highly inductive circuit of a special welding transformer.

The following chapters describe circuits of two of the capacitor discharge controls (a Taylor Winfield single-phase equipment and a General-Electric three-phase control), and also the circuit of the Sciaky stored-energy control together with a General-Electric rectifier for supplying the necessary direct current. Before studying such circuit details, let us see how the energy is stored in each of these two types of equipment, and how the simple parts of each circuit work.

**26-4. Energy Storage in Capacitors.**—When the electric energy is stored in capacitors, Fig. 26A shows very simply the

circuit used. The circuit shows a rectifier which consists of a group of tubes connected so as to change a.c. into d.c., as described later. When contacts *F* connect the a.c. power supply to the rectifier, this rectifier produces direct current, which gradually charges capacitors *C* to a high voltage. Contacts *F* open, disconnecting the rectifier from the a.c. supply, but a large amount of energy is now stored in the capacitors. With the welder

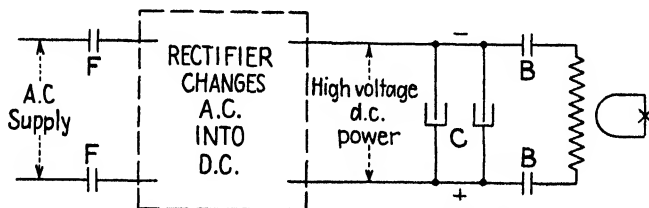

FIG. 26A.—Basic circuit of capacitor-discharge welder.

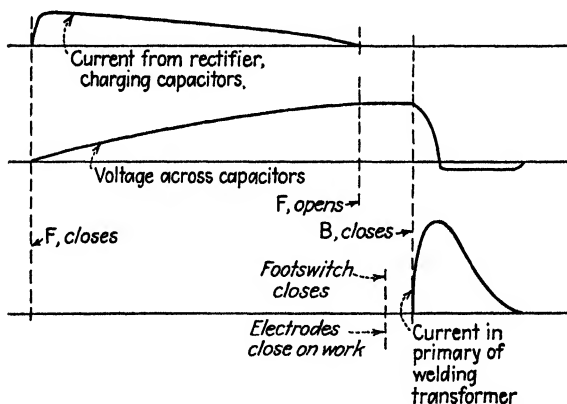

FIG. 26B.—Current and voltage in capacitor-discharge circuit.

electrodes pressed onto the work, contacts *B* close, and the capacitors now discharge their energy into the welder by forcing current from the positive capacitor terminal through the primary winding of the welding transformer and back to the negative capacitor terminal. As this current changes in the primary, the voltage in the secondary winding forces large current through the work, making the weld.

The changes in capacitor voltage and welder current are shown in Fig. 26B. Notice the small current supplied for a long time by the rectifier, which gradually increases the voltage across the

capacitors. The amount of energy stored in each of the capacitors is shown by the height of the capacitor-voltage curve. When *B* connects the capacitor to the welder and the capacitor voltage forces welding current to flow, the capacitor voltage quickly decreases to zero, but the welding current flows for additional time because of the energy stored in this transformer while its primary current was increasing. The capacitor is now discharged, and the weld is finished. It is necessary to charge the

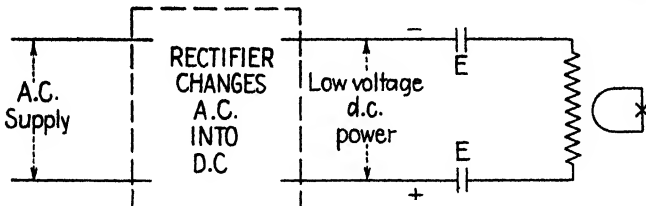

FIG. 26C.—Basic circuit of reactor-storage (Sciaky) welder.

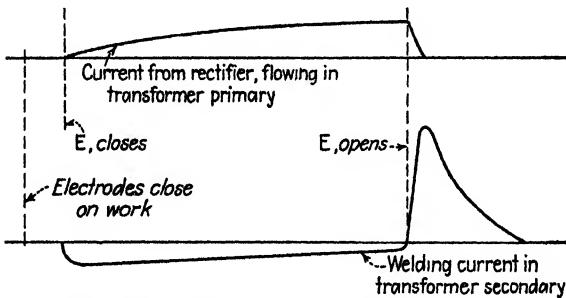

FIG. 26D.—Current in reactor-storage circuit.

capacitor again by d.c. from the rectifier before another weld can be made.

**26-5. Energy Storage in Inductance.**—For the second type of energy-storage control (Sciaky process), the circuit of Fig. 26C shows how energy is stored in the inductance of the welding transformer. The rectifier furnishes a low d-c voltage at all times. After the electrodes are pressed onto the work, contacts *E* close, and current begins to flow through the welding-transformer primary, but this does not yet make a weld. This primary current increases very slowly because of the high inductance of the welding transformer, acting like a flywheel. As it increases, the primary current gradually stores energy in the

magnetic circuit of the welding transformer. A small current also appears in the secondary winding and preheats the work. When the desired amount of direct current is flowing in the primary, the contacts *E* are suddenly opened. This stops the flow of primary current. The energy stored in the magnetic circuit (iron and air gap\*) of the welding transformer cannot escape through the opened primary circuit, but it can and does escape through the closed secondary circuit by forcing large current to flow. This secondary current makes the weld. The changes of primary and secondary current are shown in Fig. 26*D*. The amount of energy stored in the welding transformer is shown by the height of the primary-current wave.

#### 26-6. Comparing Energy of Pressure and Energy of Motion.—

To get a better knowledge of the two types of stored energy as used in the above controls, notice that the electric energy stored in capacitors is quite like the energy contained in a tank full of air at high pressure; the energy stored in the welding-transformer magnetic circuit is quite like the energy contained in a car traveling down the road at high speed.

When air is being slowly pumped into the tank, the air pressure increases slowly, until a pressure switch shuts off the pump. The pressure stays until air is used from the tank. This air under pressure in the tank is one kind of energy which can do much useful work or which can explode and do great damage if the tank is weakened. Notice that the amount of energy stored in the tank is greater when the pressure is higher, and that several tanks can hold more energy than just one tank. The tank holds its energy even after the pump is shut off, and the energy is not used until a valve is opened, letting the air supply its pressure for

\* The usual welding transformer, built on a continuous ring or closed circuit of steel, stores some magnetic energy, but not enough for use in energy-storage welding. The Sciaky welding transformer has an air gap of several inches in the steel section inside the transformer winding. Much more energy is stored in this air-gap portion than in the steel portion. Large welding machines may use an extra reactor connected across the primary winding of the welding transformer. Some of the direct current passes through this reactor, storing energy in it. When contacts *E* open, the energy in the reactor makes current continue to flow in the reactor and back through the welder primary. In this way, the reactor's energy is transferred into the main welding transformer, increasing the total energy for making the weld.



useful work. If a very large valve is opened, air may be used at a much faster rate than it was forced into the tank by the pump.

In the same way, electric energy is stored in capacitors when electric current flows into the capacitors, producing electric pressure (voltage) at the capacitor terminals. Even when this charging current stops, the capacitors still hold this energy, and are ready to give it up by forcing current through some load circuit. The welding circuit permits such large currents to flow out of the capacitor that less than  $\frac{1}{20}$  sec is needed for the capacitor to discharge all the energy that had flowed into it during  $\frac{1}{2}$  sec. Like the air-pressure tank, these capacitors receive energy slowly from a small-capacity supply line, but they can give up or discharge this energy fast enough to make a big weld.

An air-pressure tank or a capacitor can hold or store energy even when nothing is moving into or out of it. In contrast, a car stores no energy until it is moving. (We are not thinking of the energy in the gasoline tank or the pressure in the tires, but only the energy that keeps the car moving after the ignition is turned off.) A car traveling 60 miles an hour will coast much farther than the same car traveling only 30 miles an hour, which shows that there is more energy stored in the car at higher speed. A 5-ton truck will coast farther than a 1-ton car when both start to coast at the same speed. This shows that more energy is stored in greater weight of material. In the electric circuit, the amount of current flow is like the amount of car speed, and the amount of inductance of the welding transformer is like the weight of the car or truck. More energy is stored in the transformer when greater current is flowing through its primary winding or when its magnetic circuit has higher inductance. (The Sciaky welding transformer is specially built to have very high inductance so it can store a larger amount of energy.) There is no energy stored until primary current starts to flow; the amount of stored energy that can be used for making a weld depends on how much current is flowing in the primary winding at the moment when the primary circuit is suddenly opened. The weld is made by the discharge of this stored energy.

At 60 miles an hour, the large amount of energy stored in a truck does no damage (except mentally to those near by), as long as the truck does not have to stop suddenly. As it stops, it gives

up all its stored energy. If the truck stops with usual brake pressure, it gives up its stored energy gradually, traveling a city block before it stops. However, if the truck leaves the road and crashes through a row of small trees, it comes to a more sudden stop (perhaps in 100 ft), bruising the driver, severely bending the trees, but still not badly damaging the truck. If the speeding truck hits a bridge or tunnel entrance, parts of the truck stop instantly, while other parts scatter over the scenery. It takes only a second. Just before each of these three stops, the truck had the same amount of stored energy (for it had the same weight traveling at the same speed). Notice that the amount of damage depends upon how suddenly the energy is released or given up by the truck when it stops.

In the welder circuit, the stored energy depends on the amount of primary current (speed) and the transformer inductance (weight). If the current is decreased slowly, the transformer gives up its stored energy so gradually that it cannot produce a weld. However, when the welder primary circuit is opened suddenly (by the opening of contacts *E* in Fig. 26*C*), the stored energy is given up so quickly that a very large secondary current flows for a very short time, producing enough heat to make a weld. Notice that the weld is not made just because current is flowing in the welder primary winding; the weld is made when that primary current is suddenly stopped, forcing the stored energy to spill out into the secondary circuit.

#### 26-7. Treatment of Welding Transformer between Welds.—

At the end of the weld, the current in the welding-transformer primary gradually decreases to zero, as shown in Fig. 26*B* or 26*D*. Before the electrodes separate, the equipment closes a short circuit across the welder primary, so that the energy left in the transformer can escape through this short circuit instead of causing a flash at the electrodes as they leave the work. However, a small amount of magnetism still remains in the transformer and will affect the next welds. To prevent trouble from this remaining magnetism, some condenser-discharge equipments are arranged to remove the magnetism by passing a small current through the transformer winding, in the reverse direction, during the time between welds. The Sciaky circuit causes a similar magnetic reversal while storing energy for the next weld. Other stored-energy equipments use two contactors instead of the

one shown as *B* in Fig. 26A. As will be shown in later chapters, one of these contactors closes during the first weld, letting the capacitor current flow (upward) through the welder primary. To make the next weld, the second contactor closes instead, reversing the connections from the capacitor to the welder, so that the current now flows (downward) through the welder primary and is not affected by the magnetism left from the previous weld.

## CHAPTER 27

### CAPACITOR STORAGE. TAYLOR-WINFIELD HI-WAVE CONTROL

An example of spot-welding control that uses energy stored in capacitors is the Taylor-Winfield Hi-Wave control. There are several styles of these controls for handling welders of different sizes. To start with a simple circuit, the following describes a smaller style\* which takes its power from a single phase of the a-c supply.

**27-1. Elementary Diagram of Hi-Wave Control (Style 107).—**The elementary diagram of the complete capacitor-storage (or condenser-discharge) control is shown in Fig. 27A. The a-c power for the control equipment comes from lines 1 and 2 at the left of the diagram, and these lines also supply the welder, through the rectifier. Three hand-operated circuit breakers are mounted in the control cabinet. *CB1* closes the control circuit to all the relays and contactors in the lower half of the diagram. *CB2* provides two different rates for charging the capacitor, and *CB3* is the breaker in the main power circuit, acting as a disconnect. When line contactor *F* closes its contacts, a-c power passes through transformer *T2* and the rectifier tubes *V2*, *V3*, *V4* and *V5*, and reappears as a high d-c voltage between positive line 10 and negative line 11. The flow of direct current from the rectifier charges the group of capacitors to the desired voltage, and then line contactor *F* opens the a-c supply line. The operator presses a foot switch, and the relays in the lower circuit soon close the contacts of either *B* or *C* contactor, which connects the capacitors to the primary of the welding transformer. The capacitors discharge their energy to make the weld; then other relays bring the welder back to its starting

\* Most Taylor-Winfield controls use three-phase power supply and a six-tube phase-shifted rectifier and are similar in many ways to the control described in Chap. 29.

position and again close contactor *F* to charge the capacitors for another operation.

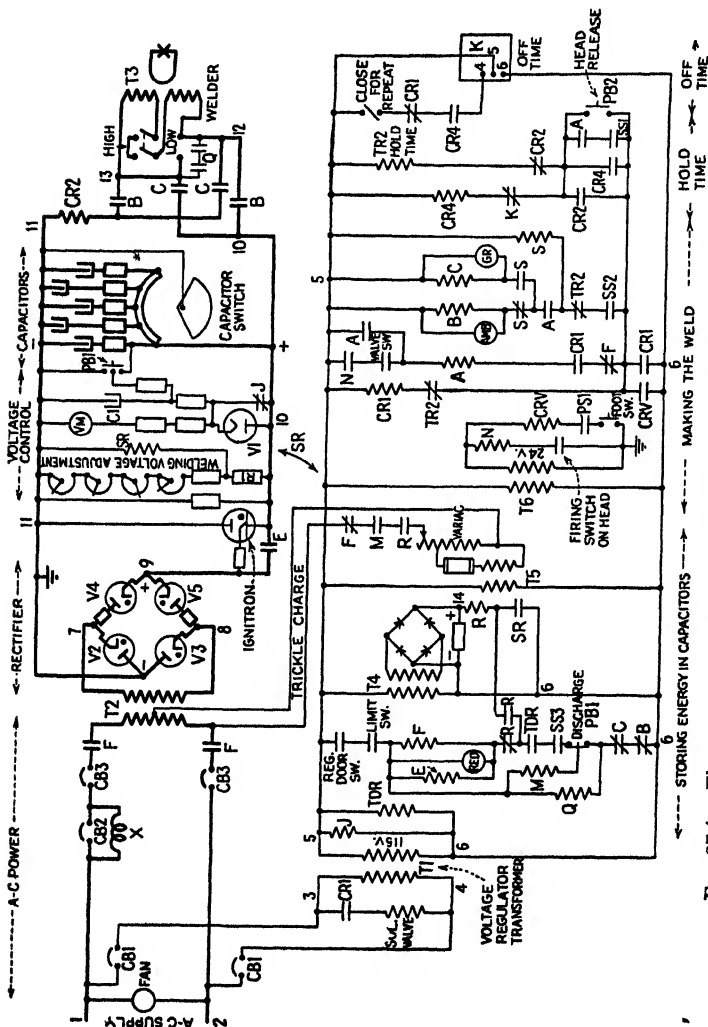

Fig. 27A.—Elementary diagram of Taylor-Winfield Hi-Wave control (style 107).

The parts of the circuit will now be explained, before the complete operating sequence is given.

**27-2. Operating the Rectifier and Storing Energy in the Capacitors.**—To get the equipment of Fig. 27A ready to operate,

a main line switch is closed (not shown). A fan starts, circulating cooling air through the control enclosure. Close circuit breaker *CB1*, energizing transformer *T1*, whose secondary winding furnishes 115 volts a.c. for operating the control circuits of the lower half of Fig. 27A. Connected across this 115-volt winding of *T1* is the time-delay relay *TDR*, which must work for 5 min before it will permit further operation. While waiting for *TDR* to operate, close breakers *CB2* and *CB3*. Also notice that *T1* is a voltage-regulating transformer, designed with special windings (and internal capacitor) so that, even though the a-c supply voltage may suddenly change from 240 to 200 volts (or from 480 to 400 volts), the 115-volt output of *T1* secondary does not change more than 1 or 2 volts. This regulation is automatic without any moving parts in *T1*.

Near *T1*, find the coil of line contactor *F*, which cannot be energized until its circuit is completed from point 5 to point 6. To energize *F*, several door interlocks and protective switches must have been closed, selector switch *SS3* is closed in the "weld" position, and the normally-closed<sup>3-15</sup> contacts of *R*, *C* and *B* are closed. While you are waiting for *TDR* to finish its 5-min timing, notice that relays *M* and *Q* are already energized (mentioned again later). When *TDR* finally closes its contact, it completes the circuit to contactor coil *F*, and also to contactor coil *E*, and lights the red signal lamp.

Contactor *F* immediately closes its contacts in the a-c supply circuit, letting this main a-c power pass through *CB3* and *F* contacts to energize transformer *T2*. The secondary winding of *T2* produces a large a-c voltage between points 7 and 8. This a-c voltage forces current through the rectifier tubes,\* finally producing as much as 3000 volts d.c. between points 10 and 11.

Notice that, during the half-cycle when 8 is (+) and 7 is (-), current flows from 8 through rectifier tube *V5* to 9, through contact *E* to 10, which connects to the positive side of the capacitors. From the negative side 11, current flows back toward the rectifier and through tube *V2* to the 7 terminal of *T2*. During the next half-cycle, when 8 is (-) and 7 is (+), current flows from 7, through tube *V4* to 9, through *E* to 10 and the capacitors,

\* These rectifier tubes are phanotrons (Type 872 or FG-104), having no control grids. Each tube passes current whenever a voltage is applied that makes its anode more positive than its cathode.

then back from 11 and through tube *V3* to 8. Current passes through tubes *V4* and *V3* at the same instant, for these tubes are connected in series, so that not more than half of the large a-c voltage (between 7 and 8) is applied across each tube.

In Fig. 27*A* the capacitors that store the energy for the weld are shown as five separate capacitors. More than five capacitor units may be used, but they are connected in five groups. All five groups are shown connected through a capacitor switch, so that they are charged to the voltage between 10 and 11. All but the first group can be disconnected from service by turning the capacitor switch counterclockwise (in a direction opposite to the movement of clock hands). This turns the upper blade of the switch so it does not connect some of the right-hand groups of capacitors to point 10. However, these disconnected groups are now touched by the lower segment of the capacitor switch, which shorts such groups to the negative terminal 11.

For the larger welds that the machine can make, most of the capacitors are used. The rectifier circuit passes enough current to charge all five groups of capacitors in less than a second. However, for small welds or thin material, only one or two capacitors are connected and store energy. If the rectifier now passes as much current as before, these few capacitors will be charged so fast (in 3 or 4 cycles) that they cannot be charged accurately to the desired voltage. To give less rectifier current and charge the capacitor more slowly, *CB2* is opened so as to connect reactor *X* into circuit. The a-c power current now passes through *X*, which chokes or decreases the current flow.

**27-3. Controlling the Capacitor Voltage.**—The amount of energy stored in each capacitor depends on the voltage to which the capacitor is charged. It is very important that the capacitors should be charged always to the same voltage so as to store the same amount of energy for each weld. If contacts *F* fail to open in Fig. 27*A*, the voltage across the capacitors may finally reach 3500 to 3800 volts. In normal operation, contacts *F* open when the capacitor voltage reaches the amount selected by the "welding-voltage adjustment," which is shown as four variable resistors\* to the right of the rectifier tubes.

\* These four resistors are arranged as a "decade box," which means that each resistor has ten steps of resistance. The top resistor has 1000 ohms per step, for coarse adjustment; the next resistor has 100 ohms per step, for

Connected across these adjusting resistors is the coil of *SR*, which is a sensitive relay that picks up always at the same voltage. By turning the four pointers so their entire resistance is in circuit, very small current flows in *R1* below, and *SR* picks up when the capacitor voltage is quite small (such as 600 to 1000 volts). By turning these pointers to decrease the total resistance, the current and voltage drop of *R1* increase, so that the capacitor voltage reaches a larger amount before *SR* picks up. This operation of *SR* stops further increase of capacitor voltage, as follows:

In the control circuit (below the rectifier) find the contact of *SR*, just below the coil of *k*. Above *R* is a small copper oxide rectifier, supplied with a.c. by transformer *T4*. When *SR* contact closes, the d-c output voltage of the copper oxide rectifier energizes *R* by passing current from 14, through coil *R* and contact *SR* to 6, and back to the negative side of the rectifier. When *R* picks up, it opens one *R* contact just below *F* coil, and this drops out *F*, opening the a-c supply line to the main tube rectifier. At the same time, *R* seals itself in through its normally-open contact, and through the contacts of *TDR*, *SS3*, *C* and *B* to 6, back to the negative side of the copper oxide rectifier.

**27-4. The Stabilizer or Trickle Charge.**—When contacts *F* open the a-c supply circuit, the capacitors have been charged to the desired voltage. Several minutes may pass before the operator presses the foot switch to make a weld; meanwhile the capacitors may lose part of their voltage and energy. To keep the capacitors fully charged to the desired voltage, a trickle-charge circuit is used, as shown in Fig. 27A. In the control circuit, transformer *T5* furnishes voltage to a Variac, or variable-voltage autotransformer, whose voltage-adjusting handle is turned so as to give the desired voltage in this stabilizer or trickle-charge circuit. Above the Variac, notice the contacts of *F*, *M* and *R*; these show that this circuit (1) does not work while *F* is energized, charging the capacitors from the a-c power supply; (2) does not work while *M* is dropped out, as when contactor *B* or *C* is picked up, making the weld; and (3) does not work until

---

medium adjustment; the third resistor has 10 ohms per step, for fine adjustment; the last resistor has 1 ohm per step for the finest (or vernier) adjustment. By turning the pointers on the four resistor dials, the total amount of resistance is very closely selected.



*R* has picked up, showing that the capacitors have been charged to the desired voltage. However, when these three contacts complete this trickle-charge circuit, a small amount of a-c power now passes from the control circuit, through *T5* and the Variac, and into part of the primary winding of *T2*. This trickle-charge circuit energizes *T2* at a reduced voltage, enough to make the rectifier voltage (between 10 and 11) just equal to the desired capacitor voltage. A small current flows to the capacitors, keeping them charged until the operator is ready to weld. Notice that contact *E* is now open, but this small current passes through the igniter circuit of an ignitron tube. (The ignitron cannot fire at this time, for its anode is more negative than its cathode. This tube fires when reverse voltage is across the capacitor at the end of a weld.<sup>29-9</sup>)

**27-5. The Capacitor Voltmeter.**—A voltmeter *VM* is connected to measure the voltage to which the capacitors are charged. When the capacitors are discharged into the welder, the capacitor voltage drops to zero, but the voltmeter does not show this low voltage between welds. When the rectifier tubes first pass current and make voltage appear between 10 and 11, this voltage forces current to flow through tube *V1*, through several resistors and the voltmeter, which now shows the voltage across the capacitor. This current also charges capacitor *C1* to this same voltage. When a weld is made by discharging the main capacitors, *C1* cannot discharge through tube *V1*, so the voltage of *C1* is still applied to the voltmeter circuit. If the voltmeter needle could drop to zero between welds, the needle would also be moving rapidly up scale while the capacitors were being charged and would overshoot just at the time when the capacitor voltage is being read. To change the voltage across the main capacitors, reset the welding-voltage adjustment and push the discharge button. The voltmeter needle moves down scale, and then rises again as the capacitors become charged to the new voltage.

When the equipment is shut down (as at the end of a day) the normally-closed contact of *J* closes around tube *V1*, so that the voltmeter now shows the true voltage across the main capacitors, indicating the voltage that still remains. Unless the capacitors are discharged by push buttons *PB1*, the capacitor voltage decreases slowly, draining through the welding-voltage-adjustment resistors and *R2*. Notice that the discharge push button

has two *PB1* contacts. The normally-closed contact drops out contactors *E* and *F* and relays *M* and *R*. The normally-open contact closes a circuit which discharges the main capacitors through their own protective resistors, and also discharges voltmeter capacitor *C1*. This total discharge current through *PB1* contact is quite large; therefore *PB1* is arranged so that it cannot reopen while this discharge current is flowing. A timing (air-bellows) device is added to *PB1* to delay the opening of its contact after the operator releases the button.

**27-6. Selecting Number of Capacitors, Voltage and Transformer Ratio.**—Before the weld is started, three selections must be made, each one affecting the weld by changing the wave shape of the welding current. Turn the capacitor switch<sup>27-2</sup> to the position that connects the desired number of capacitor units in circuit. With many capacitors connected, storing a large amount of energy, the resulting welding current flows a longer time, as needed for welding greater thicknesses of metal. With fewer capacitors connected, the welding current curve is lower, as shown in Fig. 27*B*.

Turn the welding-voltage-adjustment pointers<sup>27-3</sup> to give the capacitor voltage desired. High capacitor voltage produces a higher welding current curve than lower capacitor voltage.

Select the turn ratio of the welding transformer, if such selection is possible. Near the welding transformer in Fig. 27*A* is a double-pole, double-throw switch for this purpose. When the switch is thrown upward, to the "high" position, the current from the capacitors flows from 10, through *B* to 12, through one primary winding of the welding transformer, through the switch (shorted between poles), through the other primary winding to 13, and through the other *B* contact and *CR2* coil to 11. (If contactor *C* is closed instead of contactor *B*, the current flows from 10 through *C* to 13, through a primary winding, through the switch, through the other primary winding to 12, and through the other *C* contact and *CR2* coil to 11. The *Q* contacts are open when *B* or *C* are closed.) It is seen that the two primary windings are now connected in series, so that the turns of wire on one winding are added to the turns of the other winding; this gives the highest ratio  $\left(\frac{\text{primary turns}}{\text{secondary turns}}\right)$ . However, when the switch is thrown to the "low" position, point 12 is connected to

one side of both of the windings, and their other sides are connected to point 13. The two windings are now connected in parallel, and the number of turns of just one winding is used in the turn ratio. This connection gives the lower turn ratio, which produces a wave shape of welding current that rises more suddenly, as shown in Fig. 27B.

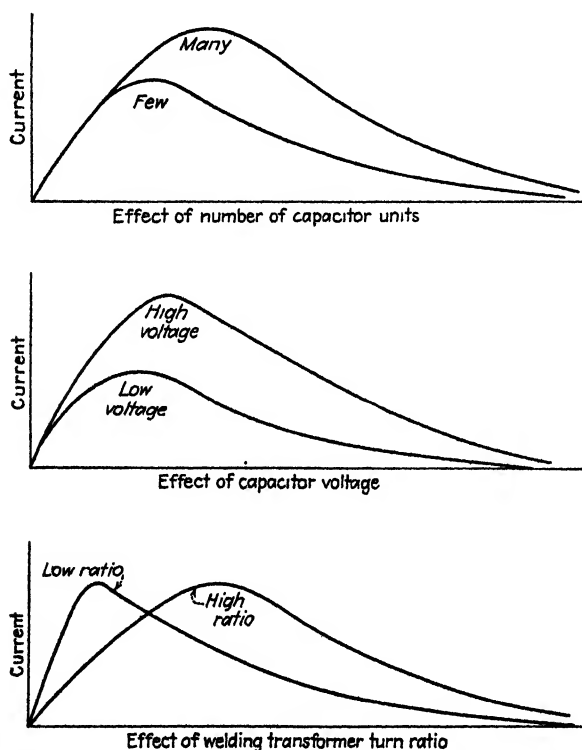

FIG. 27B.—Wave shape of capacitor-discharge-welder primary current.

After these three selections have been made and the equipment doors have been closed, the capacitors become charged, ready to make a weld. The operator now turns the pressure valve and selector switches so that the contacts of *PS1*, valve switch and *SS2* are closed. (*SS3* is also closed; *SS1* is open.)

**27-7. Starting the Welding Operation.**—The operator starts a welding operation by closing the foot-switch contact, shown in the lower center of Fig. 27A. (*PS1* contact closes when the

retractable head<sup>28-3</sup> is in the welding position.) Transformer *T6* supplies low voltage (24 volts), which energizes the coil of *CRV* when the foot switch closes. The *CRV* contact (at bottom center of Fig. 27A) picks up *CR1*, and one *CR1* contact seals around the *CRV* contact, so that the foot switch may now be released, but the machine will complete the welding operation. Another *CR1* contact, to the left of transformer *T1*, energizes the welder solenoid valve, which brings the electrodes together.

Meanwhile, another *CR1* contact (to the right of the foot switch) closes in the circuit to coil *A*. A normally-closed contact *F* keeps this *A* circuit open until the capacitors are fully charged and line contactor *F* has dropped out. Above *A* a valve switch must have been closed by turning the welder air valve to the proper position for welding. Relay *A* will now be energized just as soon as *N* closes, as next explained.

**27-8. Firing Switch.**—When the solenoid valve is energized, bringing the electrodes together, no welding current must flow until the electrodes hold the work with enough pressure. Some equipments use a squeeze-time<sup>9-2</sup> relay to delay the start of welding current until this pressure has had time to work. Instead, this Taylor-Winfield equipment uses a firing switch, mounted in the head of the welding machine, above the electrodes. When the upper electrode presses onto the work, the electrode holder slides a short distance up into the operating piston, against the pressure of an air bellows. The small motion between these two parts of the operating piston is used to close a firing switch, which closes an electric contact for a very short time; then the contact opens again. This contact is shown in the 24-volt circuit near the foot switch in Fig. 27A, and the closing of this firing switch picks up relay *N*. The contact of *N* completes the circuit\* to relay *A*, as mentioned above. Relay *A* seals itself in by an *A* contact around the *N* contact. This is necessary since the firing switch closes *N* for just an instant.

\* If the operator closes the foot switch before the capacitors are fully charged, the *N* contact will have closed and opened again before the normally-closed contact of *F* has closed its part of the *A*-coil circuit. When this happens, *A* does not pick up, and no welding current flows, but the electrodes remain together. The "head-release" push button (*PB2* at lower right) is provided on the welding machine to complete the last part of the normal sequence, separating the electrodes for a fresh start.

**27-9. Making the Weld.**—Relay *A* closes its contact, and this completes the circuit to coil *B* or to coil *C*. *B* and *C* are the two contactors that close the circuit between the energy-storage capacitors and the welding transformer. If *B* closes to pass current for one weld, then *C* closes to pass current for the next weld, as described in Sec. 26-6. *B* and *C* do not close at the same time. The device that makes *B* and *C* alternate (so that the welder current always flows in the direction opposite to the current of the previous weld) is relay *S*, one of whose contacts must close before *B* or *C* can pick up. These *S* contacts are mechanically interlocked within the relay, so that one *S* contact is always open when the other *S* contact is closed. When the *S* coil is deenergized, a ratchet falls to a new position. When *S* is again energized, it closes that *S* contact which had been open, and opens the other contact which had been closed. This operation of relay *S* happens during the time between welds, while the electrodes are coming together.

Beginning again, when the *A* contact closes, completing the circuit through one of the *S* contacts, either *B* or *C* is energized,\* as shown by the amber or green indicating lamp. The capacitors now discharge their energy into the welding transformer by forcing current from the positive capacitor terminal 10, through contacts *B* or *C*, through the primary of the welding transformer, through coil *CR2* and back to 11, the negative capacitor terminal. This current flows for a length of time that depends mostly on the connection<sup>27-6</sup> of the capacitors and the welding transformer. Relay *CR2* is operated by the current in the welder circuit so as to give a signal to start the hold time. This *CR2* relay picks up while welding current flows, but drops out when the current decreases to a low value.

**27-10. Hold Time.**—When *CR2* picks up during the flow of welding current, it operates its contacts (lower right in Fig. 27A). One *CR2* contact closes, energizing *CR4*, which seals itself in by a *CR4* contact across the *CR2* contact. At the same time, the n-c (normally-closed) contact of *CR2* remains open. However,

\* When either contactor *B* or *C* picks up, its normally-closed contact (lower left in Fig. 27A) drops out relays *Q*, *M* and *R*. Relay *Q* opens its contacts, which had been shorting the welding transformer; relay *M* stops the trickle-charge or stabilizer action of the rectifier; relay *R*, no longer needed for keeping line contactor *F* open, now resets so as to be ready for the next charging of the capacitors.

when welding current stops and *CR2* drops out, this n-c contact of *CR2* now energizes *TR2* by completing a circuit starting from point 6, through *CR1* contact and *CR4* contact. *TR2* is a time-delay relay (air-bellows type) which does not operate its contacts until after the hold time<sup>9-4</sup> is ended. When *TR2* finally operates, one n-c contact drops out contactor *B* or *C*, and also relay *S*. As *B* or *C* drops out, its n-c contact picks up relay *Q*, shorting the welding transformer primary to prevent spitting when the electrodes leave the work. Line contactor *F* also recloses, passing current to charge the capacitors for the next weld. Another *TR2* n-c contact deenergizes the *CR1* coil, so *CR1* drops out the solenoid valve, separating the electrodes from the work. If the switch is open for "nonrepeat" (to the right in Fig. 27A), the welding operation is ended. Even if the operator is holding the foot switch closed, keeping *CRV* contact closed, the electrodes still separate, but *TR2* remains energized. The operator cannot start another weld until he first releases the foot switch, resetting *TR2* and reclosing the *TR2* contact in the *CR1* coil circuit. He then closes the foot switch, starting another weld, provided the capacitors have completely recharged meanwhile.

**27-11. Repeat Welds—Off Time.**—To get automatic repeat welds, the switch is turned to "Repeat," closing the circuit from point 5 to place the off-time relay in service. This relay *K* (at right of Fig. 27A) is a tube-operated time-delay relay, described in Chap. 7 (Fig. 7C). Connections 5 and 6 supply power for the relay, but the circuit must be closed to point 4 to start the timing operation of the relay. Between the repeat switch and point 4 are contacts of *CR4* and *CR1*. *CR4* contact closes while the weld is being made. *CR1* n-c contact remains open until the end of the hold time, and then *TR2* drops out *CR1* and thereby completes the circuit to 4 of the timing relay *K*. At the end of the off time, *K* opens its n-c contact, which drops out *CR4*. Relay *CR4* drops out *TR2* (and also resets timing relay *K*). When *TR2* drops out, if the foot switch is still closed, one *TR2* contact picks up relay *S*, which opens one *S* contact and closes the other,<sup>27-9</sup> alternating the welding circuit between contactors *B* and *C*. The other *TR2* contact recloses the circuit to *CR1* coil, which brings the electrodes together, starting another welding operation. Whenever the foot switch is released, the equipment completes the weld that has begun, until the end of the

next hold time, when the welding machine stops with electrodes apart.

**27-12. Summary.**—Close *CB1* for control power and *CB3* for main power. Close *CB2* for high charging rate. After 5 min delay, *TDR* closes, picking up contactors *E* and *F*. Tubes *V2*, *V3*, *V4* and *V5* produce direct current, which charges capacitors to whatever voltage has been selected by the setting of the welding-voltage adjustment. At this desired voltage, *SR* closes its contact, picking up relay *R*, which drops out contactors *E* and *F*. *R* also closes a trickle-charge circuit, in which a Variac is adjusted to give just enough rectified voltage to keep the main capacitors fully charged.

Operator closes the foot switch in the 24-volt circuit, picking up *CRV*, then *CR1*. *CR1* seals itself in, and also picks up the solenoid valve. As the welder head comes down, the firing switch closes *N*, picking up *A*, which seals itself in. *A* picks up either *B* or *C*, which are the reversing contactors that permit the capacitors to discharge through the welding transformer, making the weld. The welder current picks up *CR2*, picking up *CR4*, which seals in. As *CR2* drops out after the weld, it energizes *TR2*, which measures the hold time. *TR2* then drops out *CR1*, which opens the solenoid valve, raising the head. *TR2* also drops out *S* and *B* or *C*, which picks up *E* and *F*, recharging the capacitors.

If the "Repeat" switch is closed, and the foot switch is still closed, the dropping out of *CR1* causes relay *K* to start the off time. The normally-closed *K* contact then resets *CR4*, which resets *TR2*, whose n-c contact picks up *CR1* again, starting another weld operation.

Each time that *TR2* resets, it picks up *S*, whose two contacts close alternately, picking up *B* on one weld and *C* on the next.

In normal welding, *SS1* contact is open, and *SS2* and *SS3* are closed. Setting the selector switch for "Mechanical operation without welding" opens *SS2* and *SS3* and closes *SS1*. Since no welding current flows, *CR2* does not pick up, so *SS1* and contact *A* energize *TR2* and complete the mechanical sequence. *PB2* also completes the sequence and raises the head for another start, whenever the operator has tried to weld before the capacitor is properly charged, so that *F* is still energized when *N* momentarily closes.

## CHAPTER 28

### REACTOR STORAGE. SCIACKY PROCESS

The operation of a spot welder using energy stored in the inductance of its welding transformer has been outlined in Sec. 26-5 (Figs. 26C and 26D) and is better known as the Sciacky process.

**28-1. Arrangement of Sciacky Equipment.**—The elementary diagram of the complete electrical equipment used with the Sciacky welding machine is shown in Fig. 28A. This includes the rectifier equipment (upper right quarter of Fig. 28A), which furnishes direct current to the welding transformer and also furnishes a small separate supply at 140 volts d.c. for control circuits. This rectifier equipment is in a separate enclosure and is built by another manufacturer, while the rest of the control is mounted as part of the Sciacky welder. Most of these control circuits operate at 220 volts a.c., as shown at the left of Fig. 28A. Another group of solenoids and contactors requires 140 volts d.c. (lower right quarter).

A number of selector switches (*SW1*, *SW6*, etc.) are mounted on the welding machine and are moved by hand to select desired operating cycles. Other switches (*S1*, *S3*, etc.) are worked automatically by the movement of parts of the machine. Three foot switches are furnished; *FS1* starts each welding operation, while *FS2* and *FS3* operate the retractable head of the welding machine. The operation of this retractable head is explained below,<sup>28-4</sup> and also the changes of electrode pressure which are included as part of the Sciacky process.\*

The main power rectifier operates from a three-phase a-c line requiring up to several hundred amperes while storing energy in the welding transformer. This rectifier is able to supply direct current at 155 volts pressure or at 80 volts, as selected by a

\* Variable pressures and retractable heads are used also on some machines already studied, but these features here become part of the main control circuit.



switch, for the welding of different thicknesses of metal. Current flows through the three large rectifier tubes (ignitrons) only when a group of d-c contactors (1 to 8 at lower right of Fig. 28A) completes the circuit through the welding transformer. This rectifier equipment will be described first before we proceed with the Sciaky control.

**28-2. Rectifier Equipment for Sciaky Process.**—The upper-right portion of Fig. 28A shows the rectifier equipment, as built

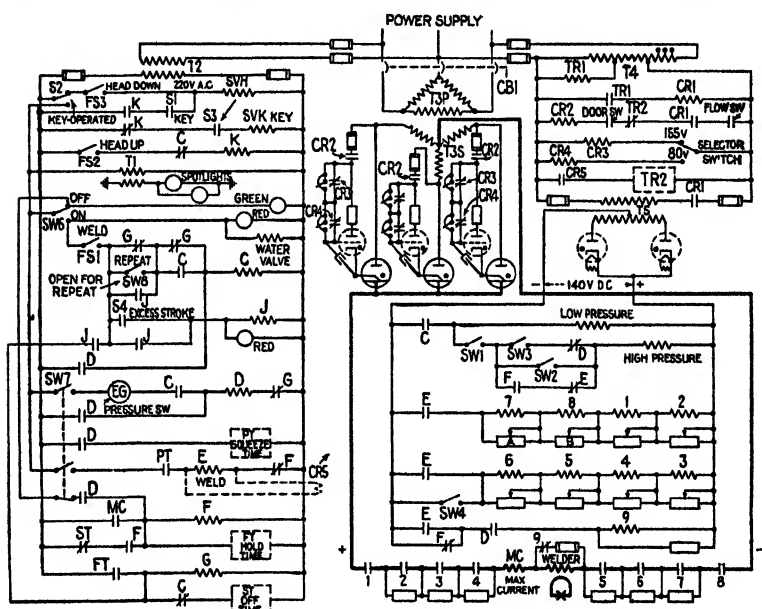

FIG. 28A.—Elementary diagram of Sciaky welder control with General Electric rectifier.

by General Electric, for furnishing direct current to the Sciaky welder and control circuits. Closing line circuit breaker *CB1* connects three-phase a-c power to the anode transformer *T3*. Each of the three *T3S* windings supplies voltage to one ignitron tube, which is the large-current water-cooled tube described in Chap. 3. These three ignitrons combine their current output to supply the welding transformer, much as a 3-cylinder engine combines its explosions to furnish useful power. Each ignitron is controlled or fired by a thyatron (Type FG-95) whose grid circuit is arranged for phase-shifting control of the voltage sup-

plied by the ignitrons, as described later. However, none of these tubes passes current until a *CR2* contact closes in the anode circuit of each thyatron.

When the a-c power-supply circuit is closed, the control power passes through autotransformer *T4* and energizes time-delay relay<sup>16-4</sup> *TR1*. After a 5-min period for warming the hot-cathode tubes on the panel, *TR1* contact closes, picking up *CR1*. One *CR1* contact energizes transformer *T5*, so that the two small rectifier tubes (Type FG-32) now supply 140 volts d.c. to the Sciaky control circuits. (This is an unfiltered pulsating voltage, which is suitable for inductive loads like contactor coils.) The other *CR1* contact closes in the circuit to the coil of *CR2*. When there is proper cooling water flowing in the ignitrons, and the rectifier doors are closed, *CR2* closes its contacts, permitting the three large ignitrons to supply current to the welder as needed.

Suppose first that tubes 1, 2 and 3 have no control grids and that each tube passes current and fires its ignitron as soon as its anode circuit will permit. Now see how ignitrons 4, 5 and 6 pass current, forced by the three-phase power supply of transformer *T3*. Figure 28B shows this part of the circuit alone.

The three branches or legs of transformer *T3* work like three separate single-phase transformers. One leg of *T3S* (between *A* and *B* in Fig. 28B) produces a single-phase, 60-cycle a-c wave, which tries to force current through tube 4, through the load and back to *A*. Figure 28C shows this voltage curve. When *B* is (+) and *A* is (-), current can pass through tube 4. Like any rectifier, tube 4 will not pass current during the other half-cycle, when its anode voltage at *B* is negative. Similarly, the next *T3S* leg (between *A* and *C* of Fig. 28B) produces a single-phase a-c wave, which tries to force current through tube 5, through the load and back to *A*. However, in a three-phase system this voltage *CA* is 120 degrees out of phase with voltage *BA*, and Fig. 28C shows the positions of these voltage waves.

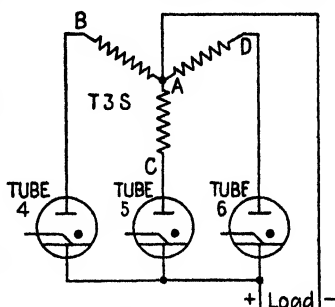

Fig. 28B.—Simple connection of ignitrons in three-phase half-wave rectifier.

When  $C$  is (+) and  $A$  is (-), current can pass through tube 5. Likewise, the third  $T3S$  leg (between  $A$  and  $D$  in Fig. 28B) produces a single-phase a-c wave, which tries to force current through tube 6. This voltage  $DA$  is 120 degrees out of phase with voltage

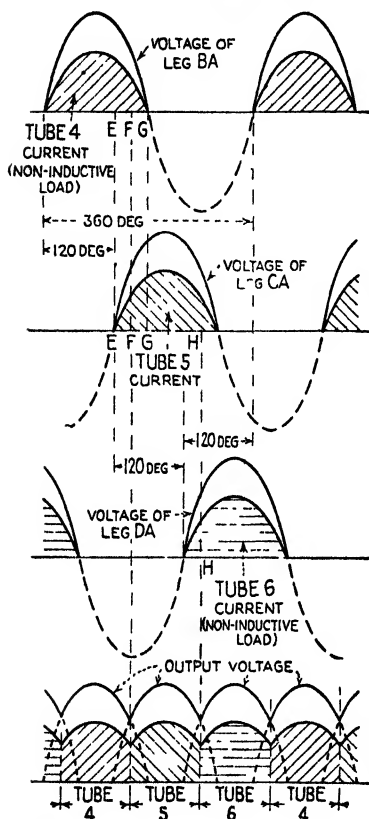

FIG. 28C.—Voltages and currents in three-phase half-wave rectifier.

$CA$ . Figure 28C shows that the curve of voltage  $DA$  is 120 degrees later (to the right) than  $CA$ , but  $DA$  is 120 degrees ahead of voltage  $BA$ . When  $D$  is (+) and  $A$  is (-), current can pass through tube 6.

It is seen that tube 4 passes current, followed by tube 5, then by tube 6, then tube 4 again, etc. The current through each of these tubes passes into the same d-c load (the Sciaky welding transformer) and back to  $A$ , the mid-point of  $T3S$ . In Fig. 28C, between  $E$  and  $G$ , it looks as though current is flowing through tube 4 and through tube 5 at the same time. However, when tubes are connected in this way and all pass current into the same load, only one tube passes current at one time. Between  $E$  and  $F$  (Fig. 28C) notice that the anode voltage of tube 4 is higher than the anode voltage of tube 5, so tube 4 passes all the current during the time to the left of  $F$ .

However, at  $F$  the anode voltage of tube 5 becomes greater than that of tube 4, so tube 5 carries all current to the right of  $F$ , until tube 5 similarly transfers the load current to tube 6 at  $H$ . Figure 28C shows that the combined output of all three ignitrons is a flow of direct current. (The peaks or ripples shown are smoothed into a steady current flow because of the highly inductive load.) The height or amount of this current is quite small when the circuit between the tubes and the welding transformer is first

closed. This current gradually increases during the time (usually less than  $\frac{1}{2}$  sec) that energy is being stored.

When the three ignitrons operate as shown in Fig. 28C, they produce slightly more than 155 volts d.c. This d-c voltage depends on the a-c voltage produced by the *T3S* windings. To be able to adjust this rectifier output closer to 155 volts, or to obtain only 80 volts output from the same rectifier when desired, a phase-shifting circuit is used to control the grid of each of the thyatron tubes 1, 2 and 3. The circuit of one of these thyratrons is shown again in Fig. 28D. Here if *CR2* contact has closed, the voltage of *T3S* is trying to force current through tube 1 into

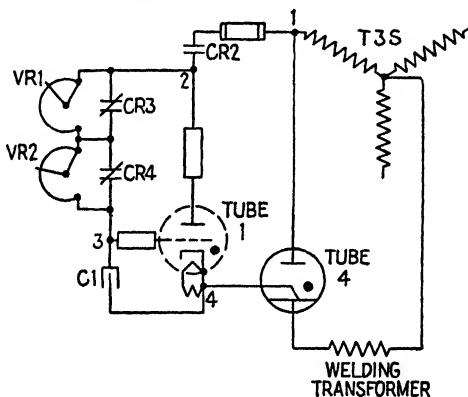

FIG. 28D.—Grid circuit for phase-shifting a rectifier.

the igniter of tube 4, so that tube 4 will pass large current into the load of the welding transformer and back to the center tap of *T3S*. However, tube 1 is controlled by its own grid voltage, measured between 3 and 4. Notice that this grid voltage at 3 depends on the voltage drop across *C1*, and this in turn depends on the current flowing through the circuit from 2 through adjustable resistor *VR1* or *VR2* to 3, and through *C1* to 4. This *C1* capacitor is not merely the small grid-to-cathode<sup>9-13</sup> protective device used so often in previous circuits. Here *C1* is larger (1 mu f) and helps control tube 1. To make the rectifier furnish 155 volts to the welder circuit, relay *CR3* is energized by a selector switch on the welder, shown in the upper right portion of Fig. 28A. This opens the *CR3* contact in Fig. 28D, inserting the resistance of *VR1* into the grid circuit of tube 1. However, to make the rectifier furnish only 80 volts to the welder circuit,

the selector switch is closed so as to energize *CR4*. This opens the *CR4* contact instead (in Fig. 28D), inserting the larger resistance of *VR2* into the grid circuit of tube 1. At the same time, other contacts of *CR4* are controlling the grids of tubes 2 and 3 in the same way. When neither *CR3* nor *CR4* contacts are open, the rectifier operates as shown in Fig. 28C, for the grids of tubes

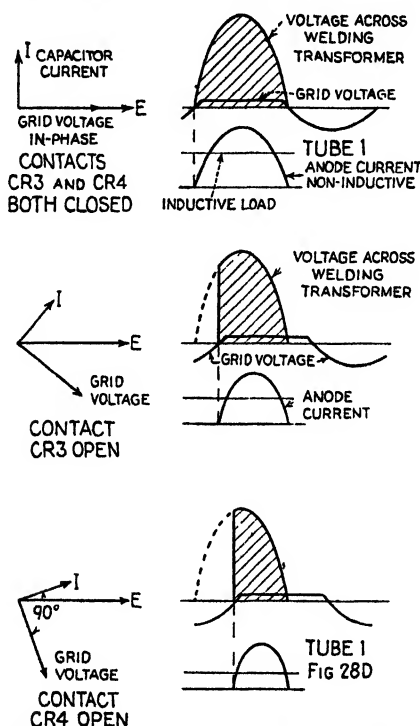

Fig. 28E.—Grid-voltage relations in a phase-shifted rectifier.

1, 2 and 3 are now shorted to their own anodes, letting the tubes operate as though they had no grids at all. However, when *CR4* opens its contacts to phase-shift the three thyatron tubes and produce only 80 volts d.c. for the welder circuit, it is of interest to see how this result is obtained.

**28-3. Phase-shifting the Three-tube Rectifier.**—The grid voltage of any tube is the voltage measured between the grid and the cathode of the tube. For tube 1 in Fig. 28D, the grid voltage is also the voltage across *C1*. This voltage changes

during each cycle, as shown in Fig. 28E. With contact CR4 open, it is seen that the resistance of VR2 decreases the amount by which the current  $I$  through C1 leads the tube-1 anode voltage  $E$ . The voltage across C1 (which always lags 90 degrees behind the current through C1) now lags considerably behind anode voltage  $E$ . The grid of tube 1 does not become positive or permit tube 1 to pass current or apply voltage to the load until much later in each cycle. Meanwhile, the firing of tubes 2 and 3 is similarly delayed. The combined result is shown in Fig. 28F, where it is seen that the rectifier now produces a jagged voltage wave. This reduced voltage causes a smaller amount of direct-current flow than in Fig. 28C. The slider of VR2 gives close adjustment of the 80-volt output of the rectifier. In the same way, when CR3 contact opens and inserts VR1 in circuit, the slider of VR1 gives close adjustment of the 155-volt output of the rectifier.

The rectifier equipment is sometimes arranged to furnish d-c power to two Sciacky welding machines, interlocked so that only one machine operates at one time. By proper automatic operation of relays CR3 and CR4, one welder may receive 155 volts d.c. from the rectifier, while the other welder may receive 80 volts d.c. from the same rectifier a moment later.

**28-4. The Retractable Welding Head.**—Most welding machines that use the stored-energy process are also equipped with retractable heads. When the operator is ready to weld, the upper electrode is brought to within  $\frac{1}{2}$  in. of the work, and it then

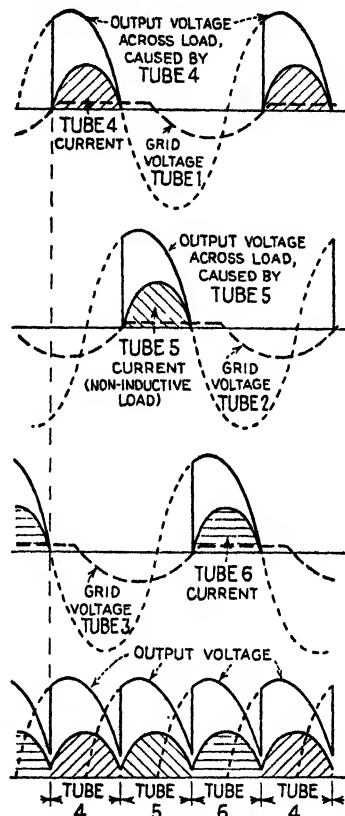

FIG. 28F.—Voltages and currents in a rectifier when phase-shifted for decreased output voltage.

moves up and down through this  $\frac{1}{2}$ -in. space, welding spot after spot. However, when it is time to change electrodes, or when a large piece of work must be moved in or out of the welder throat, the upper electrode must be quickly raised to a higher position so as to give an opening of 4 to 6 in. between electrodes. The upper electrode is retracted or withdrawn to this new position by a special combination of cylinders and pistons in the upper welder arm. This retractable head moves the electrodes only during times when no weld is intended. The head must be lowered to the operating position, where the electrode is within  $\frac{1}{2}$  in. of the work, before the actual welding operation can be started by the foot switch. In some welding machines the retractable head is operated by air or oil pressure, without electric control circuits.

The Sciaky retractable head is worked electrically by the circuits in the upper left portion of Fig. 28A. When the operator closes the foot switch *FS3*, this picks up the coil *SVH* (solenoid valve for head), which opens a valve to lower the retractable head. As the head reaches the working position, it touches and closes micro-switch *S3*, which energizes *SVK*. *SVK* is a solenoid valve which makes a steel key move into an opening in the retractable head, so as to lock the head mechanically in the working position. There is a spring that tries to reset or withdraw the key, so *SVK* must remain energized to hold the key in its locking position. The locking motion of the key also works two micro-switches. *S1* has no effect yet, but *S2* opens its upper contact, deenergizing *SVH* and removing the force that lowered the retractable head. The head remains locked by the key in the working position. *S2* closes its lower contact, completing the a-c circuit to the spotlights.\*

If selector switch *SW6* is now turned to "Foot switch on," lighting the red signal lamp, the water valve starts the flow of cooling water through the electrodes. The circuit is completed

\* Several small spotlights are mounted on the Sciaky machine, and these can be separately adjusted so as to throw small beams of light onto the work, to indicate the points where the upper electrode will touch the work and make the next welds. These lights help the operator locate the work metal so that each weld is made at the desired point or so that a line of spot welds can be made the same distance apart. The spotlights operate at low voltage supplied by transformer *T1*. The two grounded ends complete the circuit from the secondary of *T1* through the spotlights.

to foot switch *FS1*, which may now be closed to start a welding operation.

**28-5. Outline of Sciacky Control Operation.**—Before studying circuit details, let us quickly follow through the operation of the relays, contactors and timers. Remember that all a-c coils and timers are found in the left-hand side of Fig. 28A, while d-c contactors are at the lower right.

For the normal welding operation, relays *C*, *D*, *E*, *F* and *G* work in that order. There are also three a-c time-delay relays (air-bellows type) located on the welding-machine panel. Each is adjustable to give from 3 to 100 cycles time before operating its contacts. *PT* (pressure time) is similar to the squeeze time,<sup>9-2</sup> for it is the time delay before starting any current flow through the welding transformer. *FT* (forging time) is similar to the hold time,<sup>9-4</sup> for it is the length of time that pressure is held on the electrodes after the welding current flows. *ST* (speed time) is the off time<sup>9-5</sup> between two operations.

To weld, the retractable head must be down, *SW6* must be turned to "Foot switch on" and *SW7* must be turned to the "Main contactor on" position, closing the *SW7* contacts to coils *D* and *E*. When the operator closes the bottom foot switch to make a weld, this *FS1* contact picks up relay *C*. In the d-c control circuit, contact *C* energizes a d-c electric valve, which lets the electrodes press onto the work with low pressure. (Let *SW1* remain open. The use of the "high-pressure" circuit is described in Sec. 28-6.) With the desired pressure on the electrodes, a pressure switch *EG* closes its contact and picks up a-c relay *D*. *D* starts the timing of *PT*. The contact *PT* picks up relay *E*, which starts the flow of direct current through the welding transformer. The *E* contacts connect d-c control voltage to the d-c coils of contactors numbered 1 to 8, which all close their contacts at once. These 8 contacts close the circuits so that direct current starts to flow from the ignitron-tube rectifier through the primary winding of the welding transformer. When this direct-current flow reaches the desired amount, it operates *MC* (maximum-current relay), whose contact picks up a-c relay *F* (and starts the timing of *FT*). *F* drops out a-c relay *E*, and the *E* contacts open the d-c circuit to contactor coils 1 to 8. Contacts 1 to 8 open, quickly stopping the flow of direct current through the welding-transformer primary and causing the stored



energy to force welding current through the secondary circuit of the welder. Meanwhile, the electrodes hold their pressure on the welded material until *FT* finishes timing. *FT* then picks up a-c relay *G*, which drops out *D*. If *SW8* is open for a "repeat" weld, *G* also drops out *C*, which deenergizes the d-c pressure solenoid, separating the electrodes. An n-c (normally-closed) contact of *C* starts the timing of *ST*. After the off time, the n-c contact of *ST* drops out *FT*, and *FT* contact drops out *G*. If the operator is still closing *FS1*, the n-c contacts of *G* again pick up *C*, bringing the electrodes together to start another welding operation.

**28-6. Changes of Electrode Pressure during the Welding Operation.**—In the d-c control circuit (at the right-hand side of Fig. 28A) there is a "low-pressure" electric valve, and also a "high-pressure" valve, controlled through three selector switches. With *SW1* open, only one pressure cylinder forces the electrodes onto the work, at low pressure. If *SW1* is closed, two cylinders can combine to give high pressure at the electrodes. If *SW2* is also closed, this high pressure is constant, so that the electrodes squeeze the work with high pressure all during the weld (as is done by most a-c welding machines). This constant high pressure is used when the Sciaky machine welds steel or other materials having high resistance to current flow. However, if this high electrode pressure is used while welding aluminum alloys (low-resistance materials), it becomes necessary to use larger currents to produce the heat for welding.<sup>14-2</sup> (Heat =  $I^2RT$ .)

A combination of high pressure and low pressure is used during most welding of low-resistance metals. Although low pressure is used while the welding current heats the metal, high pressure then squeezes the hot pieces together. With *SW1* closed (*SW3* open) but with *SW2* open to give variable pressure, then only the low-pressure valve operates when contact *C* closes, until *E* drops out to cause the flow of welding current. *F* has already operated its contacts, so the n-c contact of *E* now completes the circuit around *SW2* and energizes the high-pressure valve. By the time the electrodes receive this higher pressure, the welding current has already reached its greatest amount, has produced its heat and is decreasing again.

In addition to this "low-high" pressure combination, it is often helpful to use high pressure to form the work pieces together

evenly before trying to weld them. (High pressure applied before the weld may be called *precompression*; after the weld it is *recompression*.) For most welding of aircraft parts, this complete "high-low-high" pressure cycle is used, as shown in Fig. 28G. (*SW1* and *SW3* are both closed; *SW2* is open. The pressure gage *EG* is now adjusted so that its contact closes only when the electrode pressure has reached the high pressure given by both cylinders working together.) When the operator closes

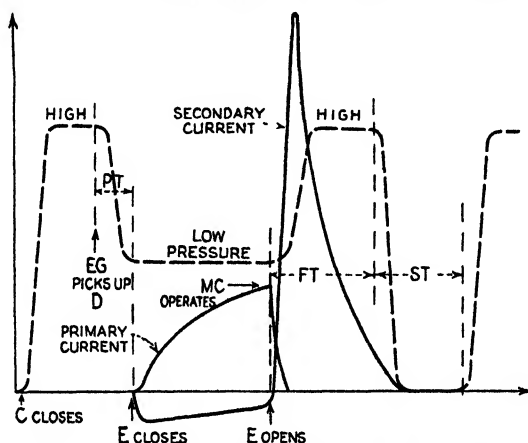

FIG. 28G.—Changes of pressure and current during weld by Sciacky process.

*FS1*, the *C* contact energizes the "low-pressure" valve, and also the "high-pressure" valve, through *SW1*, *SW3* and the, n-c contact of *D*. When the high pressure operates the pressure gage *EG*, the *D* contact drops out the high-pressure valve. (*EG* opens its contact again, but *D* has sealed itself in.) The time relay *PT* allows the electrode pressure to reach the low value before letting any current flow in the welding transformer. With this decreased contact pressure, there is greater contact resistance between the pieces of work, so greater heat is produced by the welding current. The pressure increases again and forges the hot pieces together, when the high-pressure valve is energized through the *F* and *E* contacts, as described above.

**28-7. Operating the D-c Welding Contactors.**—When the electrodes are holding the work with the desired pressure, relay *E* closes its three contacts in the d-c control circuit, picking up d-c contactors 1 to 8. (Contactors 9 was energized earlier

through n-c contact *F*, when *D* closed its contact. Contactor 9 opens a short circuit from across the welding-transformer primary.) Contacts 1 to 8 close instantly. As previously explained,<sup>26-5</sup> the direct current increases slowly through the welding-transformer primary and contacts 1 to 8 until it becomes large and stores a large amount of energy in the welding transformer. To produce a weld, this current flow must be stopped quickly, by opening contacts 1 to 8. When *E* drops out, these eight a-c contactors open separately, one after the other (as explained below), although they all open in such a short time that they seem to open all at once. The stored energy makes this circuit hard to open, for the current tries to continue flowing across the contacts as they open. This circuit cannot be opened easily by letting contacts 1 or 8 open first. Instead, contacts 4 or 5 open first, followed by 3 and 6, then 2 and 7. Notice that not one of these contacts completely opens the circuit, for each contact has a resistance connected across its tips. As each contact opens, it places more resistance in the d-c circuit. This increased resistance decreases the current in the circuit, step by step, until the smaller remaining current can be safely stopped by opening contacts 1 and 8.

To weld thick pieces, a large amount of energy is stored in the welding transformer by letting a large amount of direct current flow. This larger current is then stopped by opening all eight contacts, one after the other. However, for welding thin pieces, less energy is stored and less current must be stopped, and this smaller current can be broken by opening only four of the d-c contacts. Therefore, for light work, the selector switch (*SW4* in d-c control circuit) is closed in the "4-pole" position, so that contactors 3, 4, 5 and 6 remain closed at all times. The weld is then made by opening only contacts 2, 7, 1 and 8.

As mentioned above, these eight d-c contactors close all at once, but they are adjusted to drop out and open their contacts, one after the other. This can be easily done with contactors whose coils are energized by direct current. Notice that each contactor coil, 1 to 8, has a resistor connected across it whose resistance can be adjusted by turning the slider contact. As long as direct current flows in the coil, the contactor remains closed. When contacts *E* open, there is still enough energy stored in the magnetic circuit of each contactor to continue to force current

to flow through the coil and through the resistor connected across it. Each contactor remains closed for a period that depends on the amount of resistance across its coil. For example, to make contact 8 remain closed longer than contact 7, the slider of resistor *B* is moved to the left, decreasing the resistance of *B*. This decreased resistance permits current (induced by the decreasing flux of the contactor iron core) to circulate through coil 8 and resistor *B* for a longer time, delaying the opening of contact 8. However, by moving the slider of resistor *A* to the right, the resistance of *A* is increased so that the current flowing through coil 7 and *A* decreases more rapidly, so contactor 7 drops out before contactor 8. By these resistor adjustments, the eight contactors are made to divide the job of shutting off the direct current through the welding transformer. There should be an equal amount of flash or arc at each of the contact tips when they open the welder circuit.

During the weld, contactor 9 keeps its contact open across the welder primary. When *F* has made *E* drop out, this opens the circuit to coil 9. The resistance across coil 9 keeps contactor 9 energized for a short time. If contactor 9 resets too soon, its n-c contact closes across the welder primary before the weld is finished, and some of the stored energy makes current flow through this 9 contact, robbing the weld of some of its heat. If this happens, a fuse blows in series with 9 contact. Normally, this 9 contact closes after the welding current has nearly stopped. Then, as the electrodes separate from the work, any remaining energy discharges through contact 9 instead of flashing at the electrodes and spoiling the work.

**28-8. The Same Amount of Energy for Each Weld.**—All the energy stored in the magnetic circuit of the welding transformer is discharged into the weld. For consistent results, the same amount of energy must be stored each time, and this requires that the same amount of direct current must be broken or stopped each time. The maximum-current relay *MC* causes this by always operating at the exact amount of direct current for which it is set. *MC* is a direct-current relay, having several turns of heavy copper around an iron core. By turning a marked dial, the size of the core air gap is changed, so that the relay can be made to operate at any desired amount of current. When a greater amount of energy is needed in the weld, *MC* is turned to

a higher current setting. This increases the air gap, so that this greater amount of direct current must flow before *MC* will close its contact to start the weld.

If some device fails, so that relay *E* remains energized and does not open the d-c contactor circuit, the direct current continues to flow through *MC* and the welding-transformer primary. To prevent damage, a *CR5* relay is connected across the *E* coil. While *E* is energized, the *CR5* contact is also closed, operating time relay *TR2* in the tube-rectifier control circuit. If *E* remains energized for more than a second, *TR2* then opens its contact, dropping out *CR2* and stopping the current flow of the rectifier.

**28-9. Excess Stroke.**—If the welder electrodes are correctly adjusted, the upper electrode moves less than  $\frac{1}{2}$  in. to touch the work. To prevent operation with more than this  $\frac{1}{2}$ -in. stroke, relay *J* is included in the a-c control circuit of Fig. 28A. If the upper electrode has too much movement or stroke, it closes micro-switch *S4*, which picks up *J* and lights a red signal lamp. Relay *C* has already closed, for it energized the d-c pressure valve that caused the electrode movement. However, before *D* is closed long enough for *PT* to finish timing, one *J* contact has closed a circuit to pick up *G*. Relay *G* opens its n-c contact in the circuit of coil *D*. No weld is made. Other *J* contacts seal *J* in and keep *C* energized, so the electrodes remain pressed on the work until the operator releases *FS1*. The stroke must be decreased before a weld can be obtained.

**28-10. Repeat or Nonrepeat Operation.**—With *SW8* open (repeat), relay *G* drops out *C* and *D* at the end of the hold time. The n-c contact *C* starts *ST* timing the off time. *ST* contact then drops out *FT*, which drops out *G*. The n-c contacts of *G* reclose the circuit to *C* (if *FS1* is still closed) and *C* energizes the d-c pressure valve to start another welding operation.

With *SW8* closed (nonrepeat), relay *C* is sealed in through a *C* contact and *SW8*, so *C* holds the electrodes together as long as the operator holds *FS1* closed. The operation of *G*, at the end of the hold time, now has no effect on *C*, for *SW8* is closed around the *G* contact.

If *SW7* is turned to the "Main contactor off" position, the operator can close *FS1* and operate the electrodes, but the circuits to coils *D* and *E* are now open, so no current can flow in the welding transformer.

**28-11. Retracting the Head.**—When *FS1* is released, dropping out *C*, the operator can then pick up relay *K* by closing *FS2* (“Head-up” foot switch in upper-left corner of Fig. 28A). *K* has two contacts, one of which deenergizes *SVK* and removes the pressure that had forced the steel key into the slot of the retractable head. However, although there is a spring that now tries to withdraw the key, the key probably is still wedged or stuck because of the upward pressure thrust from the electrodes during the weld. To release the key, the other *K* contact energizes *SVH*, pushing the retractable head downward for an instant. Just as soon as the steel key is released and withdrawn by the spring from its locking position, the key switch *S1* opens, dropping out *SVH*. (*S2* returns to its upper position.) Whenever there is no downward pressure caused by *SVH*, the head is raised to the retracted position by other pressure connections.

## CHAPTER 29

### GENERAL ELECTRIC STORED-ENERGY WELDING CONTROL

Spot welding by the use of electric energy stored in capacitors has been outlined in Sec. 26-4 and Fig. 26A. One welding control using capacitor storage has been described in Chap. 27. The remaining chapters describe the capacitor-storage control, built by General Electric, for use with welding machines made by others. This equipment is shown in Figs. 29A and 29B.

**29-1. Elementary Diagram of G.E. Control (CR7503-H120).** Although this control equipment is furnished in one enclosure (including capacitors), its circuits are shown here in three related diagrams. Figure 29C shows how three-phase power is supplied, through the anode transformers *T1*, *T2* and *T3* and a six-tube rectifier, to produce direct current for storing energy in groups of capacitors (static condensers). After the rectifier is shut off, the capacitors discharge their energy into the welding transformer through a circuit including reversing contactors and several ignitron tubes. This is called the *power circuit*.

Connected to the same power supply are the low-voltage control circuits (Fig. 29D) that operate the power devices of Fig. 29C. These control circuits include the protective units, the control transformers that supply voltages to operate the tubes and several time-delay tube relays that provide sequence control<sup>9-1</sup> of the welding machine.

In order not to confuse the picture by showing too much at one time, Fig. 29C does not show in detail the many tube circuits that control the operation of the six-tube rectifier. Such circuits, which provide phase-shifting control of the rectifier tubes, together with trickle charge and gradual turn-on, are shown in Fig. 30A and discussed in Chap. 30. Even without those circuits, there is plenty that requires attention here.

**29-2. Outline of Power Circuit.**—In Fig. 29C the a-c power for the entire equipment is received from the three wires at the left

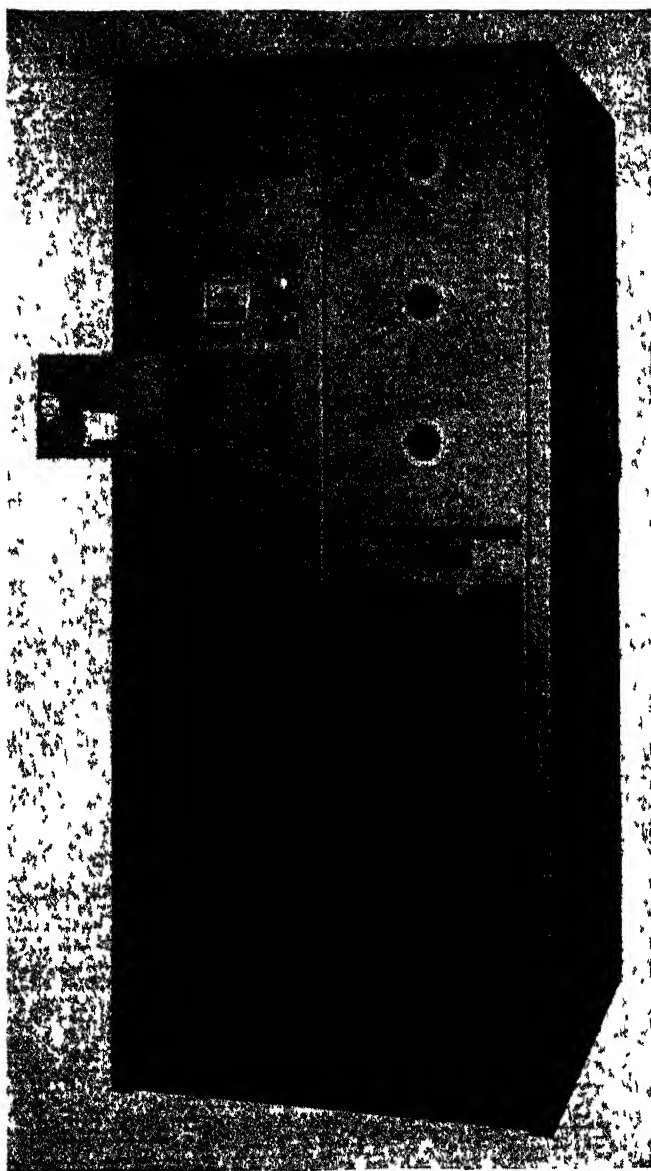

FIG. 29.4.—General Electric capacitor-discharge control, CR7503-H120, front view



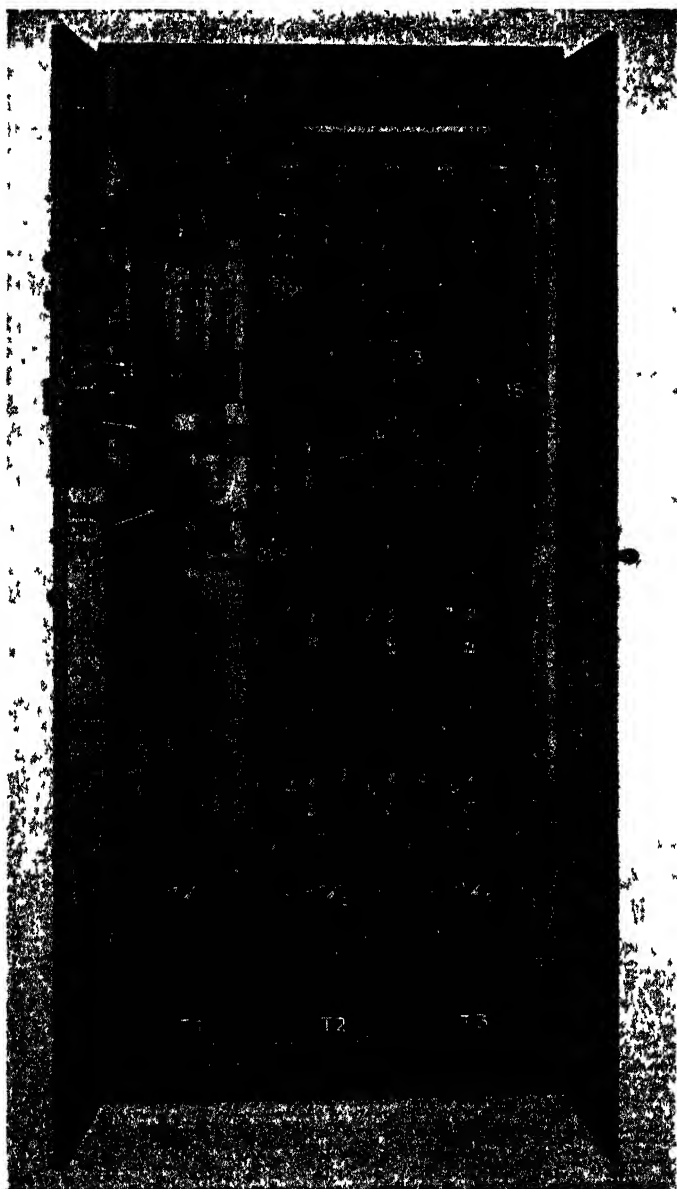

FIG. 29B.—General Electric capacitor-discharge control, CR7503-H120, inside view.

side. (These power feeders may be much smaller than are needed for most a-c welders.) When the main line switch is closed, a blower circulates cooling air through the control enclosure. When line contactor *L* closes its three contacts, transformers *T1*, *T2* and *T3* are energized and supply high voltage from their secondary windings at *A*, *B* and *C* to rectifier tubes 1, 2, 3, 4, 5, and 6. Tubes 1, 2 and 3 (Type FG-104) have no control grids, but they can pass current only when tubes 4, 5 or 6 are also firing. Tubes 4, 5 and 6 are thyratrons (FG-105), whose control grids have complete control of the average current flowing through these tubes for charging the capacitors.

From the bottom or cathode of tubes 4, 5 and 6, direct current flows from positive terminal 15A into the group of capacitors (3C to 11C). From the upper or negative side of the capacitors, current returns to the rectifier by passing through capacitor-switching relays (A1 to A4) to 29, through current-limiting resistor *R1*, through one of tubes 1, 2 or 3, and back to transformers *T1*, *T2* and *T3*. The capacitors are charged to a voltage shown on voltmeter *VM*.

As yet there is no circuit or flow of current through the welding transformer (at right). After the capacitors are charged, the rectifier tubes are turned off by their grid circuits. To make a weld, one of the two contactors *D1* or *D2* must close its contacts, and then ignitron tube 14 is fired by its thyatron tube 15. Ignitron 14 completes the circuit, and the capacitors discharge their energy to make a weld by forcing current from the positive terminal 15A of the capacitors through contacts *D1* or *D2*, through the primary winding of the welding transformer and through ignitron 14 to point 29, and through the capacitor-switching relays to the negative side of the capacitors. When the welding-transformer reactance (acting like a flywheel) keeps this primary current flowing long enough to produce reversed voltage across the capacitor, this voltage fires tubes 17 and 16, which protect the capacitor from high reversed voltage.

**29-3. Outline of Control Circuits.**—The circuits of Fig. 29D receive their power from the three wires (upper left corner) through *SW1* in Fig. 29C. Two wires energize transformer *T4*, which furnishes 115 volts a.c. to pick up line contactor *L*, capacitor-shortening contactor *CRS* and reversing contactors *D1* or *D2*. Transformer *T5* is energized from another phase, and furnishes

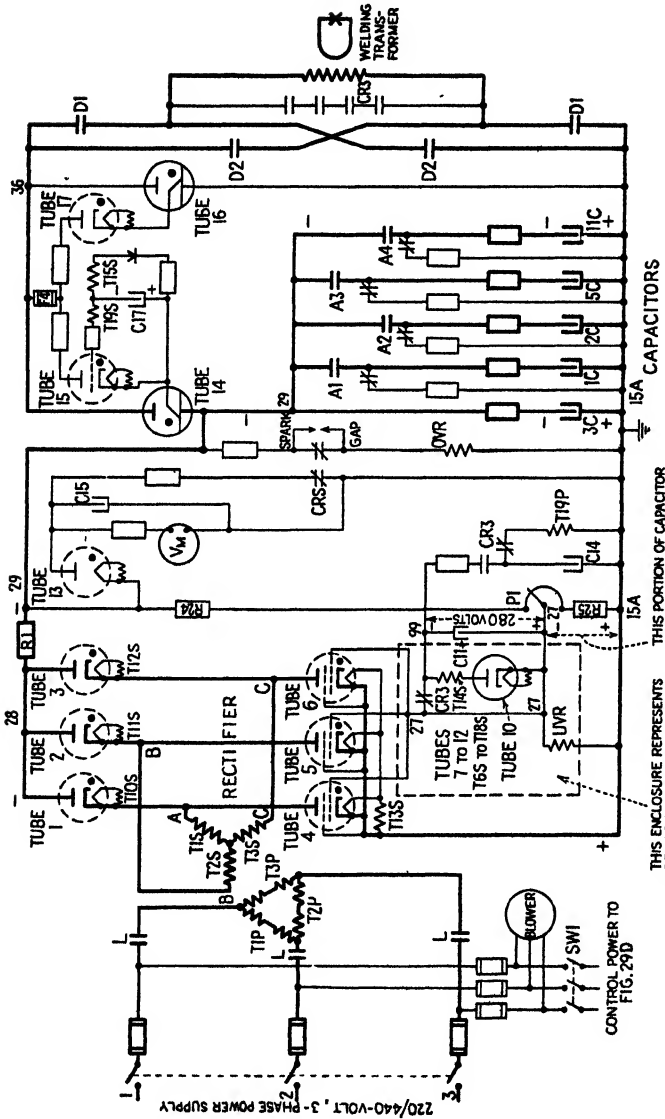

Fig. 29C.—Power circuit of G.E. capacitor-discharge control.

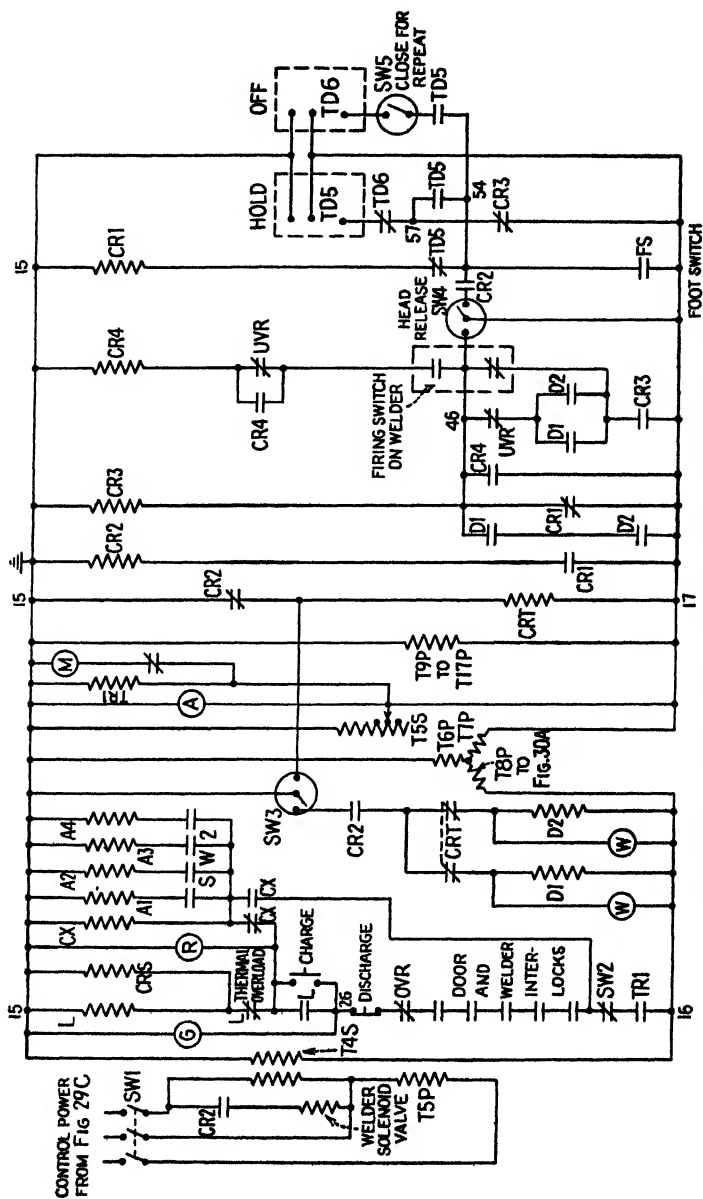

Fig. 29D.—Control circuit of G.E. capacitor-discharge control.

115 volts a.c. to timing relay *TR1* and to transformers *T9* to *T18*, most of which provide filament and anode voltages for the tubes in Figs. 29C and 30A. At the right side, *TD5* controls the length of the hold time, and *TD6* controls the off time, when switch *SW5* is closed for repeat operation. These two time-delay relays are tube-operated, like those described in Chap. 9. In Fig. 29D the dotted enclosure of *TD5* or *TD6* includes the same parts and circuit shown in Fig. 9D. *TD5* starts timing when the circuit is closed to the bottom terminal shown. (The two upper terminals merely provide a.c. for the tube circuit.) No time-delay relay is used for a squeeze time, but a firing switch is used on the welder and operates its contacts when the electrodes have the right pressure. Figure 29D shows a firing switch with two contacts. Here the normally-closed contact is used for starting the weld, and the normally-open contact helps to prevent a weld if the main capacitors are not yet charged to the proper voltage.

When control switch *SW1* is closed, all the tube filaments start to heat, and *TR1* starts its timing. *TR1* is the 5-min time-delay relay.<sup>16-4</sup> After the tubes have been warmed for 5 min, the *TR1* contact closes (lower left in Fig. 29D). If the doors of the control equipment are closed, the door interlocks and *TR1* contact complete the circuit from point 16 to 26, lighting the green lamp on the panel. The "Charge" button can now close the circuit to contactor *L*, to charge the capacitors in Fig. 29C.

**29-4. Rectifier Operation, Charging the Capacitors.**—When the "Charge" button closes, the circuit from 15 to 16 (top to bottom in Fig. 29D) is closed through the coils of line contactor *L* and *CRS* and lights the red light, showing that the rectifier is "on." *CRS* opens its two contacts (near the center of Fig. 29C), which open the safety discharge circuit across the capacitors. *L* seals itself in,\* and the three *L* contacts (at left in Fig. 29C) complete the circuit to anode transformers *T1*, *T2* and *T3*. When the rectifier tubes 1 to 6 first start to pass current, there is no voltage across the capacitors or from positive point 15A (bottom) to 29 (top). Therefore, there is no voltage across potentiometer *P1* (lower center), for *P1*, *R24* and *R25* are a voltage divider<sup>16-11</sup> connected across the capacitors. *P1* is the

\* A normally-closed *L* contact opens if the anode transformers become overloaded by too frequent charging of the capacitors.

adjustment for selecting the voltage to which the capacitors are to be charged.

To see what grid voltage lets tubes 4, 5 and 6 pass current at this time, trace the circuit from the grid of the tubes to point 27, through *P1* and *R25* to point 15*A*, and back to the cathodes of the tubes. Since there is no voltage across *P1* and *R25*, the grids are at the same potential as the cathodes, so tubes 4, 5 and 6 pass current to charge the capacitors. After part of a second, however, the capacitors have become charged to more than 800 volts. Part of this 800 volts also appears across *P1*. Notice that any point on *P1* is now more negative than point 15*A*, and the slider on *P1* applies this negative voltage to the grids of tubes 4, 5 and 6. If the *P1* slider is turned to the upper end (toward *R24*), then point 27 becomes so negative when the total capacitor voltage is about 800 volts that it prevents the tubes from firing additional cycles. However, with *P1* turned to the lower end (toward *R25*), the capacitors become charged to about 3000 volts before the slider 27 reaches the same negative voltage as before and prevents the tubes from firing further.\* As the voltage across the capacitors increases, the voltage between *P1* slider 27 and point 15*A* also increases, with slider 27 gradually becoming more negative than point 15*A*. The tube grids, connected to 27, receive this negative bias. The voltage between 27 and 15*A* is also used to pick up relay *UVR*.† *UVR* is a "voltage inspector," which does not pick up unless the capacitor voltage has reached the amount for which *P1* is set. *UVR* must pick up before a weld can be made, as will be shown later.

**29-5. Rectifier Lockout.**—A contact of *CR3* is used (just below tube 6) to make sure that the rectifier tubes are shut off during the weld, and to prevent the rectifier from recharging the capacitors too soon after the weld is completed. This *CR3* contact is open while the rectifier tubes are charging the capacitors. However, soon after the operator closes his foot switch, *CR3* closes this contact, connecting grids 27 to point 99. Notice that point 99 is about 280 volts more negative than point 27

\* Remember that this description of the control of tubes 4, 5 and 6 is only approximate at this time. The complete detail of this grid circuit is explained in Chap. 30, after the rest of the control is better understood.

† Relay *UVR* is an optional addition to the standard control.

because of the d-c voltage across  $C11$ .  $T14S$  produces a-c voltage which is rectified by tube 10, which passes current that charges  $C11$  to this voltage. When connected to 99, the tube grids have such negative voltage that tubes 4, 5 and 6 are completely locked out, or prevented from firing. However, the main purpose of this  $CR3$  contact appears when the capacitors discharge their energy to make the weld. At that instant the voltage across the capacitors decreases to zero, so the voltage across  $P1$  also becomes zero. This removes the negative voltage between 27 and 15A, so the grids immediately let tubes 4, 5 and 6 pass current. This is prevented by keeping the grids connected to the more negative voltage at point 99 through  $CR3$  contact. In this way the rectifier is prevented from charging the capacitors again until  $CR3$  opens this contact at the desired time.

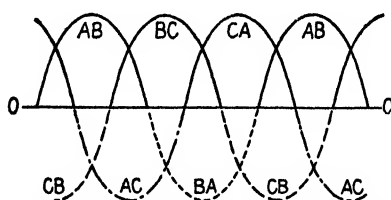

FIG. 29E.—Voltage waves of three-phase anode transformers ( $T1$ ).

**29-6. The Six-tube Rectifier.**—Tubes 1 to 6 operate as a three-phase, full-wave rectifier and produce a d-c voltage that has six peaks or ripples during each cycle of the a-c power supply, as shown in Fig. 29G. To see what causes these six peaks, first notice that tubes 4, 5 and 6 alone would operate like the three-tube rectifier described in Sec. 28-2, producing a voltage wave like Fig. 28C. (While the power tubes in Sec. 28-2 are ignitrons handling large currents at low voltage, tubes 4, 5 and 6 in Fig. 29C are hot-cathode thyratrons designed to carry smaller current at higher voltages.) Figure 29E shows the waves of a-c voltage produced by the secondary windings  $T1S$ ,  $T2S$  and  $T3S$  in Fig. 29C, where the ends of these windings are marked  $A$ ,  $B$  and  $C$ . Starting with the windings between  $A$  and  $B$ , curve  $AB$  (in Fig. 29E) shows the voltage wave when  $A$  is (+) and  $B$  is (-). During the next half-cycle, when  $A$  is (-), the continuing curve  $BA$  is shown dotted below the 0-0 line. Transformer lead  $A$  is connected to the anode of tube 4, so tube 4 passes current when

$A$  is (+) (while curve  $AB$  is above the 0-0 line), but tube 4 cannot pass current when  $A$  is (-) (while curve  $BA$  is below the 0-0 line). Similarly, curve  $BC$  is the voltage wave when transformer terminal  $B$  is (+) and  $C$  is (-) and current can pass through tube 5; curve  $CA$  is the voltage wave when terminal  $C$  is (+) and  $A$  is (-) and current can pass through tube 6.

Now see what happens when all six tubes are used. During the peak of curve  $AB$ , when transformer terminal  $A$  is (+) and  $B$  is (-), current starts from  $A$  and passes down through tube 4 to point 15A and to the capacitors. Returning from 29 (negative side of capacitors), this current goes through  $R_1$  and through

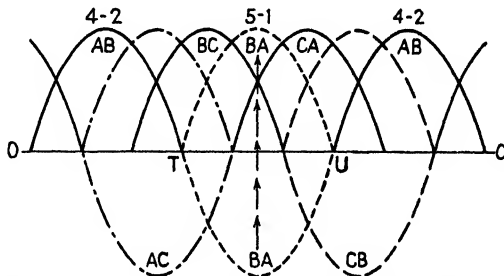

FIG. 29F.—Inverted voltage waves produced by rectifier action.

whatever tube completes the circuit to  $T_1$ -terminal  $B$ , which is seen to be tube 2. Place this information in Fig. 29F by marking 4-2 above peak  $AB$ , showing that current flows through tubes 4 and 2 at this part of the wave. Still using transformer terminals  $A$  and  $B$ , but a half-cycle later when  $A$  is (-) and  $B$  is (+), it is seen that current cannot flow in the reverse direction, up through tubes 2 and 4. However, notice that current can flow from  $B$  down through tube 5 to the capacitors, returning through  $R_1$  and tube 1 to  $A$ . This shows that current flows in the same direction to the capacitors even during the peak of wave  $BA$  (which is below the 0-0 line in Fig. 29E). To show this rectifier action, in Fig. 29F we turn curve  $BA$  upside down to a new place above the 0-0 line, but crossing the 0-0 line at  $T$  and  $U$ , the same as before. During this peak  $BA$ , current flows through tubes 5 and 1, so 5-1 is marked above peak  $BA$ . (Notice that peak  $BA$  takes its place naturally half way between peaks  $BC$  and  $CA$ .) In the same way, if we follow the voltage wave between transformer terminals  $B$  and  $C$ , it will be seen that



current flows from  $B$  (+) through tube 5 to capacitors, returning through tube 3 to  $C$  (-); a half-cycle later, current flows from  $C$  (+) through tube 6 to capacitors, returning through tube 2 to  $B$  (-). In Fig. 29G the final result is shown. Notice how the tubes transfer the current load from one to the other (in much the same way that a man transfers his weight from one foot to the other when walking). For example, at  $X$ , tube 4 continues to fire, but the load is transferred from tube 2 to tube 3; at  $Y$  (60 degrees later), tube 3 still continues to fire, but the load is transferred from tube 4 to tube 5.

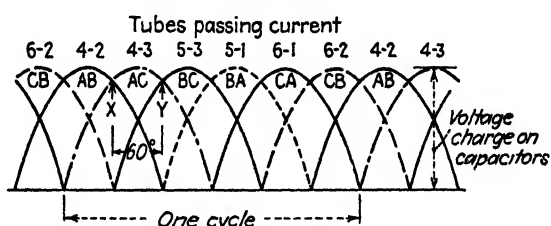

FIG. 29G.—Output voltage wave of six-tube rectifier.

**29-7. Voltmeter and Spark-gap Circuits.**—As previously described, voltmeter  $VM$  is connected to measure the voltage to which the capacitors are charged. The voltage across the capacitors (between points 29 and 15A in Fig. 29C) also forces current through tube 13 and charges capacitor  $C15$ . When the main capacitors discharge their energy into the weld, and lose their voltage in doing so, tube 13 prevents  $C15$  from discharging also. The voltmeter continues to indicate the same voltage as before, even while the main capacitors are discharging and recharging. This prevents the voltmeter pointer from swinging. If  $P1$  is turned, to decrease the capacitor voltage, the discharge button must be pushed before  $VM$  can show this lower voltage. (The discharge button drops out  $CRS$ , whose contact discharges  $C15$ . As the main capacitors become charged to a lower voltage, this lower voltage also appears across  $C15$ , so  $VM$  now correctly shows the voltage of the main capacitors.)

When the discharge button is pushed, another  $CRS$  contact discharges the main capacitors, which force current through the coil of  $OVR$  relay.  $OVR$  opens its normally-closed contact (between 26 and 16 in Fig. 29D). Therefore, even if the discharge button is quickly released, this  $OVR$  contact prevents  $CRS$

from picking up again and opening its contacts, until the discharge current through these contacts has decreased to an amount small enough to let *OVR* drop out.

When the rectifier is charging the capacitors, the *CRS* contacts are open. No current now flows through *OVR*, for there is a protective spark gap in this circuit. Whenever the rectifier fails to stop charging the capacitors and the capacitor voltage rises above about 3150 volts, current then jumps across the gap and picks up *OVR*, whose contact drops out *L* and stops the rectifier.

**29-8. Selecting Number of Capacitors.**—The number of capacitors that will store energy for the weld is selected by capacitor-switching relays *A1*, *A2*, *A3* and *A4*, whose contacts (right center in Fig. 29C) are in the high-voltage capacitor circuit. Capacitor *3C* represents three capacitor units\* or cans, each rated 120 mu f. When *A1* closes, one additional unit *1C* is connected in circuit. Relay *A2* adds two units *2C*; relay *A3* adds five units *5C*; relay *A4* adds eleven units *11C*. The total number of capacitor units furnished is recommended by the welding-machine manufacturer.

When any relay (*A1* to *A4*) drops out, its normally-closed contact discharges the capacitors connected to it. The coils of relays *A1* to *A4* are shown in Fig. 29D (upper left) and are energized in various combinations by contacts on selector switch *SW2*. Before *SW2* can be turned, to select a different number of capacitor units, a normally-closed *SW2* contact opens (at lower left in Fig. 29D), and this opens line contactor *L* and also discharges the capacitors. With *SW2* in the desired position, the charge button is then pushed; this picks up relay *CX*, which seals itself in, and picks up whichever relays *A1* to *A4* are con-

\* Each unit is separately protected by a  $\frac{1}{2}$ -ohm resistor. This resistor does not greatly affect the usual current that charges or discharges the capacitor unit. However, if a capacitor unit becomes shorted internally, the energy stored in the other units may force a large flow of current into this short circuit. The amount of this current is limited by the  $\frac{1}{2}$ -ohm resistor, and the remaining capacitors are permitted to discharge more gradually through the shorted unit. The resistor may also act as a fuse, disconnecting the shorted unit.

Some recent capacitor units are built with internal current-limiting reactance so that the external  $\frac{1}{2}$ -ohm resistors are not required with these units.

nected through the selector contacts of *SW2*. The desired number of capacitors become charged, and the equipment is now ready to make a weld.

**29-9. Starting the Welding Operation.**—When the operator closes the footswitch *FS* (lower right in Fig. 29*D*), this picks up *CR1*, whose contact (lower center) picks up contactor *CR2*. One *CR2* contact seals around the foot switch, keeping *CR1* closed even though the foot switch is released. Another *CR2* contact (left center) picks up either *D1* or *D2*,\* through one of the contacts of *CRT*. *CRT* is a transfer relay which closes its left contact during one weld and picks up *D1*, whose contacts (in Fig. 29*C*) steer the capacitor discharge current upward through the welder primary. For the next weld, the other (right) *CRT* contact is closed, picking up *D2*, whose contacts steer the capacitor discharge current in the opposite or downward direction through the welder primary. White lamps are connected across the coils of *D1* and *D2*, to show which of these reversing contactors is closed at that moment.

Another *CR2* contact (at left of Fig. 29*D*) energizes the solenoid valve that brings the electrodes together onto the work. As the electrodes squeeze the work and the welder head applies the right pressure, the firing switch in the welder head operates, opening the lower (normally-closed) contact and closing the upper (normally-open) contact, shown in Fig. 29*D*. Notice that this lower contact of the firing switch drops out relay *CR3* because the other near-by contacts are open before this firing switch operates. (1) Contacts *D1* and *D2* do not close at the same time. If they accidentally close together, *CR3* is prevented from dropping out. (2) The normally-closed contact of *CR1* opened when the foot switch closed. (3) *UVR* picked up when the capacitors were charged to the right voltage, so the *UVR* contacts are now open (and *CR4* cannot pick up).

The drop-out of relay *CR3* is the signal that starts the flow of welding current as shown below. [Meanwhile, several *CR3* contacts open the circuit across the welding-transformer primary. Another *CR3* contact (shown under the rectifier tubes in Fig. 29*C*)

\* The contacts of *D1* or *D2* do not complete the circuit that discharges the capacitors into the welding transformer, but merely set up the circuit, waiting for tube 14 to finally close the circuit. *D1*, *D2* and *CRT* work together in the same way that *B*, *C* and *S* operate in Sec. 27-9.

connects points 17 and 99, completely preventing the rectifier from passing further current. Still another *CR3* contact closes between 17 and 57, starting the hold time.] Notice the two *CR3* contacts in lower center of Fig. 29C. Before *CR3* drops out, its normally-open contact connects capacitor *C14* to point 99. As already explained, point 99 is 280 volts more negative than point 27. With the main capacitors charged, point 99 is about 400 volts more negative than point 15A. This 400-volt supply charges *C14*, which stores energy. When *CR3* drops out, its n-o contact disconnects *C14* from the 400-volt supply, and its n-c contact connects *C14* to the primary winding of transformer *T19*. The energy stored in *C14* now discharges, causing a surge of current through *T19P*. This produces a voltage peak in *T19S* to fire ignitron tube 14 and start the weld, as next explained.

**29-10. The Capacitors Discharge, Making the Weld.**—The main capacitors discharge their energy into the welding transformer by forcing current to flow from the positive capacitor terminal 15A, through contacts *D1* or *D2*, through the welder primary winding, returning through tube 14 to the negative capacitor terminal 29. This discharge circuit is finally closed when ignitron tube 14\* fires.

When contacts *D1* or *D2* are closed, but before tube 14 fires, the voltage of the main capacitors appears between the anode and cathode of tube 14, and also across tube 15, which is the thyatron used for firing ignitron tube 14. Tube 15 would pass current as soon as *D1* or *D2* closed, but its own grid circuit keeps it from doing so. In the grid circuit of tube 15, transformer *T15* supplies a-c voltage, which passes through a disk-type rectifier<sup>4-12</sup> so as to charge capacitor *C17* to about 200 volts d.c. Since *C17* is more negative at its upper end, the grid of tube 15 is held 200 volts more negative than its cathode, so tube 15 cannot pass current. However, when *CR3* drops out, as described above, and lets *C14* discharge through *T19P*, a voltage peak appears in *T19S* which is greater than the 200-volt bias of *C17*. This *T19S* voltage makes the grid of tube 15 positive, letting current pass through fuse *F4* and tube 15 into the igniter of tube 14. Tube 14 completes the circuit, letting the capacitors force current through the welding transformer. Figure 29H shows how this

\* Tubes 14 and 16 are GL-415 (Size A) ignitrons, which are cooled by a jet of air since water cooling is not used in this 3000-volt equipment.

current increases to a high peak, rising from *A* to *B*, while capacitor voltage forces this current to flow. However, when the capacitor voltage has decreased to zero at *D*, the discharge current has reached its highest amount at *B*. The current does not immediately decrease to zero, for the energy stored by this current in the welding transformer now forces current to continue to flow, gradually decreasing as the energy decreases.

**29-11. Preventing Reversed Capacitor Voltage.**—The current that continues to flow after the capacitor voltage drops to zero

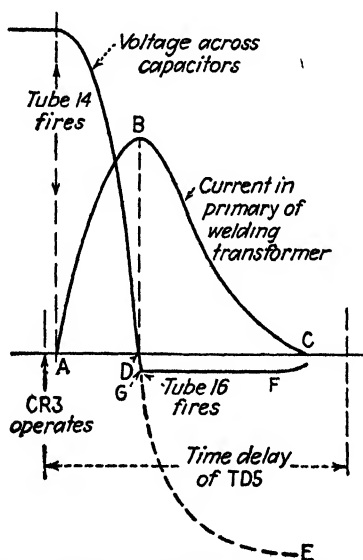

FIG. 29H.—Capacitor voltage and current during weld.

at *D* will charge the capacitors in the reverse direction, as shown by the dotted line from *D* to *E*. Since a large reversed capacitor voltage must be prevented when the most economical high-voltage capacitors are used, tubes 17 and 16 are used to drain this reversed voltage away from the capacitors.

Before tube 14 fires, it is seen that both the anode and cathode of tubes 17 and 16 are at the positive potential of point 15*A*. When tube 14 first fires (between *A* and *B* of Fig. 29H), the anode 36 of tubes 17 and 16 is more negative than the cathode 15*A*, so these tubes cannot pass current. However, as soon as the capaci-

tors are charged about 150 volts in the reverse direction, as at *G*, the anode 36 becomes enough more positive than cathode 15A, so that tube 17 immediately passes current (since it has no grid to delay its firing) and fires ignitron tube 16. Tube 16 by-passes the current that flows in the welding transformer, so this current does not charge the capacitors to more than 150 volts in the reverse direction. This voltage is shown at *F*, and drains closer to zero as the welder current finally dies out. This reversed voltage at *F* also removes anode voltage from tubes 15 and 14, so that they stop passing current, and the grid bias of *C17* regains control of tube 15.

**29-12. Hold Time.**—When the firing switch drops out *CR3* to start the flow of welding current, the n-c contact of *CR3* closes (lower right in Fig. 29D), completing the circuit to *TD5*. The length of the hold time is adjusted so that *TD5* operates its contacts shortly after the welding current has ended, as shown in Fig. 29H. Contacts of *TD5* control many operations; (1) one *TD5* contact closes between 54 and 57, keeping *TD5* energized; (2) another *TD5* contact closes in the circuit to the off-time relay *TD6*; (3) a n-o contact of *TD5* opens between 15 and 54, dropping out *CR1*. The n-c contact of *CR1* closes between 17 and 46, picking up *CR3*, whose contacts close around the welding-transformer primary to prevent spitting when the electrodes separate from the work. Another *CR3* contact (normally-closed) disconnects the rectifier-tube grids 27 from negative point 99 (in Fig. 29C), letting the rectifier start to pass current and charge the capacitor for another weld. Another *CR1* contact drops out *CR2*, which lets the solenoid valve separate the welder electrodes. *CR2* drops out *D1* or *D2*. An n-c contact of *CR2* picks up transfer relay *CRT* (center of Fig. 29D). If *D1* had closed during the previous weld, *CRT* now opens the contact leading to *D1*, and closes the other *CRT* contact, so that *D2* will pick up during the coming weld. When *CRT* drops out again, these *CRT* contacts are not moved.

If *SW5* is open (at right of Fig. 29D) for a "nonrepeat" weld, *TD5* remains energized by the circuit through *TD5* and *TD6* contacts as long as the operator holds the foot switch closed. Meanwhile, the electrodes are apart, and the operator must release the foot switch (dropping out *TD5*) and reclose it before another welding operation can be started.

**29-13. Repeat Welds—Off Time.**—If *SW5* is closed for “repeat” welding and the operator keeps the foot switch *FS* closed, a *TD5* contact completes the circuit to *TD6*, which controls the length of the off time during which the electrodes are apart. When *TD6* finishes its timing, its normally-closed contact drops out *TD5*. Through the foot switch and n-c contact of *TD5*, *CR1* is again picked up and energizes *CR2* and the solenoid valve, bringing the electrodes together for another spot weld. *CR2* picks up *D1* or *D2*.

If the off time is set too short so that the electrodes come together before the rectifier has had time to charge the capacitors to the desired voltage, *D1* or *D2* will pick up before *UVR* has been picked up by proper capacitor voltage. Next to the firing switch, a circuit is completed through contacts of *CR3*, *D1* or *D2* and *UVR* (normally-closed), which prevents relay *CR3* from being dropped out by the firing switch. If the *UVR* contacts are still closed when the firing switch closes its upper (normally-open) contact, a circuit is completed to the coil of *CR4*, which closes its contacts to hold itself in even after *UVR* finally picks up and opens its two contacts. No weld is made, since *CR3* is prevented from dropping out. However, the electrodes remain pressed on the work even though the operator releases the foot switch. Operating the “Head release” switch *SW4* (lower right in Fig. 29D) opens the holding circuit so *CR1* can drop out, thereby dropping out *CR2* and separating the electrodes for a fresh start.

**29-14. Operation for Electrode Adjustment.**—To bring the electrodes together without passing any welding current, switch *SW3* is turned to the “Mechanical-operation-without-welding” position. The foot switch now brings the electrodes together, but the open *SW3* contact prevents *D1* or *D2* from closing the circuit between the capacitors and the welding transformer. The firing switch drops out *CR3* in the usual way. The *SW3* contact, closed to the right, keeps *CRT* picked up so that it does not make unnecessary transfer operations.

## CHAPTER 30

### GRID CONTROL OF SIX-TUBE RECTIFIER

The previous chapter shows the complete operation of the welder circuit of the General Electric stored-energy control, but does not show how the rectifier tubes are grid-controlled so as to start the charging operation gradually, or so as to obtain quickly a trickle charge of the capacitors. This chapter describes the complete grid circuit of the six-tube rectifier shown in Fig. 29C.

**30-1. Elementary Diagram of Rectifier Grid Circuits.**—Figure 30A shows the circuits that control the grids of rectifier tubes 4, 5 and 6, which charge the capacitors in the previous chapter. These circuits of Fig. 30A fit into the enclosure shown below tubes 4, 5 and 6 in Fig. 29C. To see what parts of the circuit of Fig. 30A directly control the rectifier, it is necessary to trace the circuit from the grid of a rectifier tube, such as tube 4, back to its cathode. Starting at grid 74, trace to 78, across C5 to 85, to the right and across R9 to 90, up through R12 and R11 to 92, down across C10 to 94, right to the slider of P1, down through R25 to 15A, back to the left and up to the cathode of tube 4. Similarly, the grid of tube 6 connects to 80, and across C7 to 85, there joining the tube-4 grid circuit. Tube-5 grid connects to 79 and across C6, but to point 84 instead of 85, and therefore includes the a-c voltage of T9S before reaching point 85. The circuit between 85 and P1 controls the grids of tubes 4, 5 and 6 together as a group, and no a-c voltages appear in this part of the circuit.

In the lower center of Fig. 30A, the circuit of tube 12 and P2 is the "voltage inspector," which must approve of the voltage to which the capacitors are charged before it will pick up UVR\* and permit the weld to be made. See Sec. 30-7 below.

As described in Sec. 29-4, the simpler circuit in Fig. 29C can turn the rectifier tubes off when the increasing capacitor voltage forces P1 slider and the rectifier tube grids more and more

\* Relay UVR is an optional addition to the standard control.



negative than cathode 15A. However, thyatron tubes in such a simple circuit are either "all on" or "all off," passing full current or none at all. The purpose and advantage of the Fig. 30A circuit are that it can control the thyratrons gradually, increasing or decreasing the amount of current just enough to trickle-charge the capacitors after they have been quickly charged.

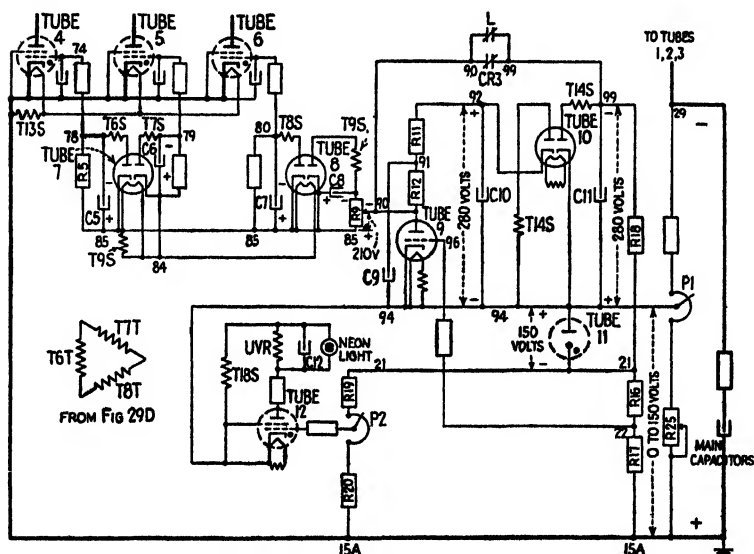

FIG. 30A.—Rectifier grid circuit of G.E. capacitor-discharge control.

**30-2. Phase-shifting Circuit.**—Thyatron tubes cannot be controlled by their grids so as to change the amount of current passing through the tubes unless a phase-shifting circuit\* is applied to the grids to make the thyratrons fire earlier or later in each cycle of the a-c power supply.

To phase-shift the grid circuit of tube 4, the voltage across capacitor  $C5$  is used; at the same time, the voltage across  $C6$  phase-shifts tube 5, and the  $C7$  voltage gives phase-shift control of tube 6. In the circuit of tube 4, for example, the voltage across  $C5$  is produced by transformer winding  $T6S$ , whose a-c voltage is rectified by the left side of tube 7 (Type 25Z6,

\* Phase-shifting grid circuits are used for heat control of welders. See Sec. 19-3.

double-anode vacuum-tube rectifier), so as to charge *C5* negative on its upper side toward the grid of tube 4. Transformer *T6* is one of the three transformers shown near the center of Fig. 29*D* and connected to the three-phase control-power supply through transformers *T4* and *T5*. The tertiary windings *T6T*, *T7T* and *T8T* (lower left in Fig. 30*A*) help to balance the load between these three transformers. This is of value since each transformer secondary is loaded singly in turn.

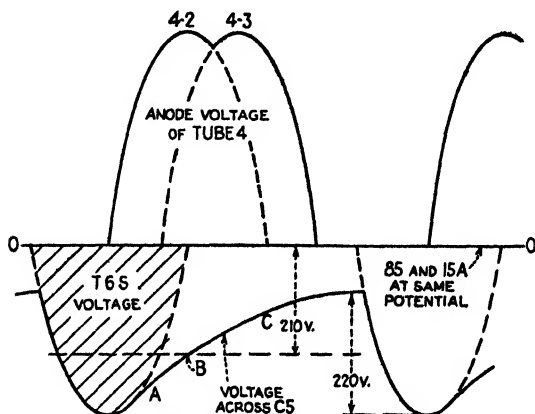

FIG. 30*B*.—Sawtooth grid voltage for phase-shifting the rectifier.

Figure 30*B* shows the a-c anode voltage of tube 4 and the voltage of *T6S*, which charges *C5* to about 285 volts. After the *T6S* voltage peak is past, *C5* discharges through *R5* at such a rate that the voltage across *C5* decreases to about one-fourth its previous voltage before the *T6S* peak of the next cycle recharges *C5*. On this curve of *C5* voltage, the slanting part between *A* and *C* is used to fire tube 4. Of course, in the position shown in Fig. 30*B*, the grid voltage never comes up to the 0-0 line, and tube 4 does not fire. However, if the entire grid-voltage curve is raised by adding about 210 volts d.c. into the grid circuit, Fig. 30*C* shows that the grid voltage of tube 4 now crosses the 0-0 line at *B*, in time to fire tube 4 near the middle of its period of anode voltage.\* To do this in the circuit of Fig. 30*A*, the tube

\* In Fig. 30*C* the main capacitors (such as *3C* in Fig. 29*C*) have been charged nearly to the desired voltage, so all the rectifier tubes are being phase-shifted so that they pass current during only part of each period of

grid voltages are raised 210 volts by the voltage produced across *R9*. (The right half of tube 8 rectifies the a-c voltage of *T9S* and charges *C8* to about 250 volts, most of which appears between points 85 and 90, which is the slider on *R9*.)

In the same way, the grid voltage of tube 6 includes the voltage across *C7*, which is a "sawtooth" wave like Fig. 30*B*. Since the peak voltage of *T8S* comes from transformers connected to the same phase that supplies the anode voltage of tube 6, tube 6 is fired near the middle of its own period of anode voltage, as shown

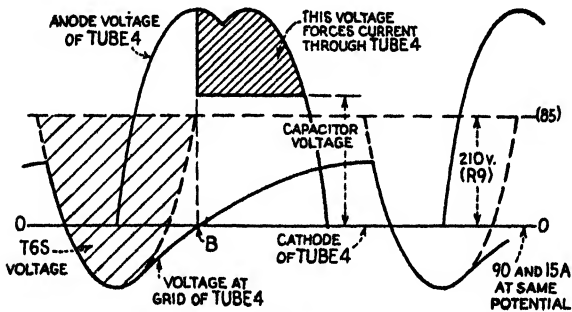

Fig. 30*C*.—Rectifier phase-shifted for reduced current output.

in Fig. 30*C*. However, as mentioned above, the grid circuit of tube 5 includes not only the sawtooth voltage across *C6*, but also the a-c voltage of *T9S* (22.5 volts). Figure 30*D* shows that this *T9S* a-c voltage, when added to the capacitor voltage curve of Fig. 30*C*, produces a new curve of grid voltage which crosses the 0-0 line earlier and lets tube 5 fire during a larger portion of its period of anode voltage. In this way, when the grid-voltage level of all three tubes is lowered, tube 5 may be made to pass a small amount of current, even when tubes 4 and 6 have entirely stopped. This operation of tube 5 alone provides better control of the low-current trickle charge mentioned later.

These sawtooth waves of grid voltage may be compared to a comb. You do not try to comb your hair with a flat stick, for you need the teeth of the comb to separate the hairs. (The

anode voltage. Notice that current flows only while the tube anode voltage is greater than the voltage of the capacitor.

In Fig. 30*D* the level of grid voltage is lower (because of more current flowing through tube 9) so tube 5 passes current for a very small part of each period, and tubes 4 and 6 may not be passing any current.

sawtooth waves of grid voltage are needed to phase-control the tubes.) Holding the comb in your hand, you comb no hair until you push the comb close enough to your head. If the comb is withdrawn slightly, the teeth touch only a few hairs. If one of the teeth is longer than the others, it is more useful for the last delicate touch to the hair. (Similarly tube 5, still passing small current after the other tubes have stopped, is useful for the trickle charge.) When the comb is further away from the hair, the teeth are still on the comb, but the moving hand combs no hair. In

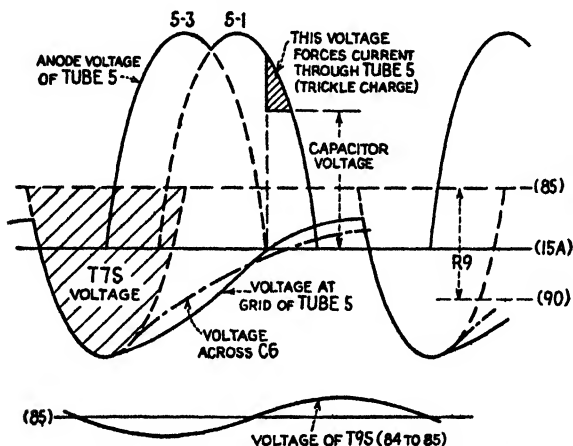

FIG. 30D.—Rectifier phase-shifted for trickle charge.

the same way, the sawtooth waves are always present in the grid circuit of tubes 4, 5 and 6, and they are raised or lowered in a group like the teeth of the comb. The voltage at point 90 is like the solid back of the comb.

We have seen how the phase-shifting sawtooth waves are made. Now let us see what lowers the voltage level of the grid circuit (like the solid back of the comb), carrying the sawtooth waves along with it, so as nearly to shut off the rectifier.

**30-3. Rectifier Operation—Charging.**—When the grid-voltage level is high, all the rectifier tubes pass maximum current, and this is the condition needed for the most rapid charging of the welder capacitors. In Fig. 30A, notice that point 90 is held at a potential 280 volts higher than point 94. (Assume that CR3 and L contacts are open between 90 and 99. There is no voltage drop across R11 or R12 at this time; tube 9 is not passing current;

capacitor *C10* is charged to 280 volts d.c. by the voltage of *T14S*, rectified by the left half of tube 10. The top end 92 of capacitor *C10* is more positive than the lower end at 94.) Therefore, the grids of tubes 4, 5 and 6 are at a potential several hundred volts higher than shown in Fig. 30*C*. The phase-shifting control is not effective now, and all tubes pass maximum current. Figure 30*E* shows the changes of rectifier grid voltage during the charging operation, starting at *A*, with the grids (point 90) several hundred

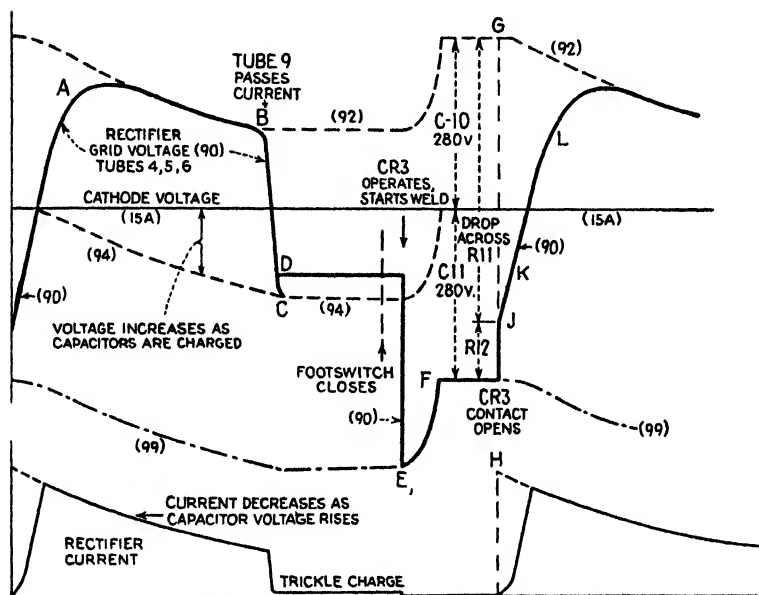

FIG. 30*E*.—Changes of rectifier grid voltage during charge and weld.

volts more positive than the cathodes (point 15*A*). As voltage appears across the main capacitors (at right of Fig. 30*A*), part of this voltage gradually makes point 94 (slider of *P1*) more negative than 15*A*. The grids of tubes 4, 5 and 6 gradually decrease in potential at the same rate until, at *B* in Fig. 30*E*, they are only 130 volts positive, but the tubes still pass maximum current. The voltage between 94 and 15*A* is now 150 volts, and the capacitors have been charged to the voltage for which *P1* is set.

During this charging period, there has been no current flowing through tube 9. Notice that tube 9 is a high-vacuum tube (Type

6SJ7 pentode, with two other grids not shown) whose current flow is gradually controlled by the potential of its grid 96.

In Fig. 30A, trace the circuit that controls tube 9, from grid 96 to point 22, across *R16* to 21, and across tube 11 to 94, connected to the cathode of tube 9. The constant voltage across tube 11 keeps the grid of tube 9 negative, so that tube 9 does not pass anode current during the charging period.

**30-4. Voltage-regulator Tube.**—Tube 11 in Fig. 30A is a voltage-regulator tube,\* whose only purpose is to keep constant voltage between two parts of the circuit. It has an anode and a cold cathode and has a gas inside it. There are several kinds of voltage-regulator tube, containing different kinds of gas, each designed to hold some certain voltage between its anode and cathode. Most thyratron tubes containing mercury act as regulator tubes to hold about 20 volts difference between anode and cathode, because 20 volts is the natural voltage drop where electric current passes through a gas of mercury vapor. In the same way, 150 volts is the natural voltage drop across tube 11, in which electric current passes through neon gas at certain pressure.

The current flowing through a voltage-regulator tube must also pass through a resistance. In Fig. 30A the current through tube 11 also passes through *R18*. The transformer winding *T14S* (upper right) supplies a-c voltage which is rectified by the right half of tube 10. Part of the current through tube 10 keeps *C11* charged to 280 volts d.c. The rest of the current through tube 10 passes down through tube 11 to point 21, returning through *R18* to 99 and *T14S*. With 280 volts applied between points 94 and 99, tube 11 holds 150 volts between points 94 and 21, and the rest ( $280 - 150 = 130$  volts) appears across *R18*. *R18* is a 10,000-ohm resistor, so a current of 13 milliamperes must flow through tube 11 and *R18* to produce 130 volts drop across *R18*. Suppose a sudden drop in a-c line voltage reduces the *T14S* voltage, so that only 250 volts appears between 94 and 99. Tube 11 still keeps 150 volts across it, between 94 and 21, by decreasing its current until only 100 volts appears across *R18*. To make this possible, the current through tube 11 and *R18* decreases to 10 ma. Similarly, if the *T14S* voltage suddenly

\* Tube 11 is a type VR-150-30 tube, which shows that the voltage between its two terminals is always 150 volts when a current of less than 30 milliamperes (0.030 amp) is passing through it.

increases, producing 320 volts between points 94 and 99, tube 11 immediately increases its current to 17 ma, so as to cause 170 volts drop across  $R_{18}$  and still leave just 150 volts between points 94 and 21.

Such a voltage-regulator tube is used in Fig. 30A because the voltage between points 94 and 21 controls the hold-off bias on

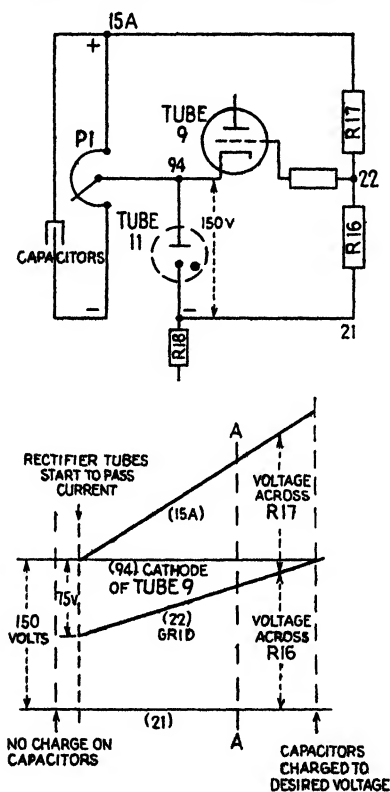

FIG. 30F.—Grid circuit of tube 9.

tubes 9 and 12, and this voltage must be held constant if tubes 9 and 12 are to pass current always just as the capacitors become charged to the desired voltage.

**30-5. Controlling Tube 9.**—The grid circuit of tube 9, which includes voltage-regulator tube 11, is shown again in Fig. 30F, and is rearranged so more positive voltages are toward the top. Before the charging of the main capacitors begins, there is no

voltage across the capacitors, and no voltage between  $P1$  and  $15A$ . Therefore  $15A$  is now at the same potential as  $94$ , as though the top of  $R17$  were connected to  $94$ . The voltage from  $15A$  (top of  $R17$ ) to  $21$  (bottom of  $R16$ ) is now 150 volts, the constant voltage across tube 11. Since  $R16$  has the same resistance as  $R17$ , half of this 150-volt drop is across  $R16$ , and point  $22$  is now 75 points more negative than  $15A$ . This potential at  $22$  is connected to the grid of tube 9, while point  $15A$  is at the same potential as cathode  $94$ , so tube 9 is kept from passing current because of this 75-volt negative bias on its grid.

As the rectifier tubes pass current and charge the capacitors, d-c voltage appears across the capacitors, and part of this capacitor voltage also appears between  $15A$  and the slider of  $P1$ . By the time that the capacitors have reached about two-thirds of the desired voltage, point  $15A$  has become about 100 volts more positive than point  $94$ , as shown at  $A-A$  in Fig. 30*F*. The voltage from  $15A$  to  $21$  has increased to  $150 + 100 = 250$  volts, which is the voltage across  $R16$  and  $R17$  together. Half of this, or 125 volts, appears across  $R16$ , so point  $22$  (grid of tube 9) is now only 25 volts more negative than  $94$  (cathode of tube 9), but still tube 9 passes no current.

As the capacitors become charged close to the desired voltage for which  $P1$  is set, point  $15A$  becomes nearly 150 volts more positive than point  $94$ . Voltage from  $15A$  to  $21$  is nearly 300 volts, so the voltage across  $R16$  is nearly 150 volts. Point  $22$  (grid) is at nearly the same potential as  $94$  (cathode) and tube 9 starts to pass current, which increases quickly just as the capacitor voltage reaches the desired amount.

**30-6. Rectifier Operation at Trickle Charge.**—The problem now is to shut off the rectifier tubes quickly so that the capacitor voltage cannot rise further or overshoot, and yet to permit the rectifier to trickle-charge to keep the capacitors at their present voltage. As just described, tube 9 passes current just as the capacitors reach the desired voltage. As this current quickly increases, passing from point  $92$  (in Fig. 30*A*) through  $R11$ ,  $R12$  and tube 9 to point  $94$ , it causes voltage drop across  $R11$  and  $R12$ , so that the voltage at point  $90$  is quickly decreased to within 20 to 50 volts of point  $94$ . As shown in Fig. 30*E*, this makes the grid potential of tubes 4, 5 and 6 drop suddenly toward  $C$ . Although the grid potential at  $B$  lets the rectifier



tube pass full current, the grid potential at *C* is so much lower that the rectifier tubes are entirely shut off. However, as the voltage of the charged capacitor decreases slightly, owing to gradual leakage, this lowers the grid voltage of tube 9 a small amount, decreasing the current flowing through vacuum tube 9. This raises the grid potential of tubes 4, 5 and 6 to *D*, where perhaps tube 5 alone passes a small amount of current, enough to trickle-charge\* the capacitors and keep them at the desired voltage until ready to make a weld.

**30-7. Voltage-inspector Circuit.**—Although the circuits just described have complete control of the voltage of the capacitors, extra protection may be furnished by a separate tube circuit which prevents any welding operation unless the capacitors have been properly charged to the desired voltage. This inspection of the capacitor voltage is made by the circuit of tube 12 (lower center of Fig. 30A). Tube 12 must pass current and pick up relay *UVR* before any welds can be made. As the capacitors become charged, the capacitor voltage controls tube 12 in the same way as tube 9 is controlled in Fig. 30F, for the cathode of tube 12 is at nearly the same voltage as 94, the cathode of tube 9; the grid of tube 12 is at about the same voltage (on *P2*) as point 22 or the grid of tube 9. By close adjustment of *P2*, tube 12 is made to pass current and pick up *UVR*, at the same capacitor voltage that causes tube 9 to trickle-charge. The transformer winding *T1&S* can force current through *UVR* and tube 12 in only one direction. Capacitor *C12* is connected across the coil of *UVR* to prevent chattering<sup>7-21</sup> by discharging through *UVR* during the half-cycles when tube 12 does not pass current.

**30-8. Rectifier Lockout.**—With the capacitor fully charged and with *UVR* picked up, a weld is started when relay *CR3* drops out (in Fig. 29D). One normally-closed contact of *CR3* closes (at top of Fig. 30A) and locks out the rectifier, preventing tubes 4, 5 and 6 from passing any current. This *CR3* contact connects point 90 to point 99, which is 280 volts more negative than point

\* This condition of trickle charge is shown in Fig. 30D. Notice that, if *P1* is set so the capacitors are charged to a lower voltage, tube current can now flow later during the cycle; too much current flows while tube-5 grid is at the level shown in Fig. 30D. However, tube 9 regulates this condition and passes more current, lowering the voltage level of tube-5 grid and delaying the firing of tube 5 until still later in the cycle, so that tube 5 passes just enough current to trickle-charge the capacitors at this lower voltage.

94 (because of the d-c voltage across  $C11$ ). As shown in Fig. 30E, the potential at 90 drops to  $E$ , but, as the capacitors discharge into the weld and lose their voltage, 90 rises to  $F$ , where it remains, holding the rectifier-tube grids negative. Meanwhile, since voltage between  $P1$  and  $15A$  has disappeared, tube 9 regains its 75-volt negative grid bias and no longer passes current.

While the weld is being made, the  $CR3$  contact keeps the rectifier from passing current. As long as  $CR3$  contact connects 90 to 99, there is a voltage drop of 560 volts across  $R11$  and  $R12$  in series, as shown in Fig. 30G.

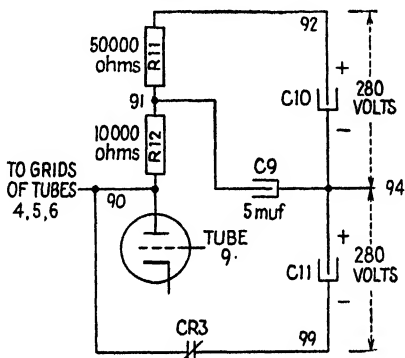

FIG. 30G.—Grid control of rectifier during lockout and start of charging operation.

**30-9. Gradual Starting of Rectifier Current.**—When  $CR3$  opens its contact at the end of the hold time, current stops flowing from point 92, through  $R11$  and  $R12$ , to point 99, so point 90 tries to rise immediately to the potential of point 92, as shown at  $G$  in Fig. 30E. If this is permitted, the grids of tubes 4, 5 and 6 become positive so quickly that the rectifier passes full current,\* as shown by the dotted line at  $H$ . To prevent this sudden current inrush, capacitor  $C9$  is connected between points 91 and 94 (in center of Fig. 30A, and shown again in Fig. 30G).

Notice that  $R11$  is 50,000 ohms, that  $R12$  is 10,000 ohms, and that there is 560 volts drop across the total of 60,000 ohms, while  $CR3$  contact is still closed. Therefore, 467 volts appears across  $R11$ , and 93 volts across  $R12$ . Point 91 is now 93 volts above point 99; point 94 is 280 volts above point 99; so point 94 is 187

\* If only one or two capacitor units are connected in service, this large current can charge them to the desired voltage too quickly to permit accurate voltage control.

volts above point 91, and capacitor  $C9$  is charged to this voltage difference of 187 volts, being more negative at the end connected to 91.

With  $C9$  connected as shown in Fig. 30G,  $CR3$  now opens its contact and current stops flowing through  $R12$ . Since there is no voltage drop across  $R12$ , point 90 immediately rises 93 volts to the potential of point 91, as shown at  $J$  in Fig. 30E. However, the voltage drop across  $R11$  does not change rapidly from 467 volts because capacitor  $C9$  tries to keep this voltage unchanged. There still is voltage drop across  $R11$ , caused by current flowing from positive point 92 through  $R11$  to charge gradually the large (5  $\mu$  f) capacitor  $C9$ . As  $C9$  slowly becomes charged to the voltage between points 92 and 94 (becoming positive at the end connected to 91), the current flow decreases through  $R11$ , letting the potential of point 90 slowly rise to  $K$ , as shown in Fig. 30E. When the potential of 90 rises to  $K$ , the rectifier is passing the same amount of current as when it is trickle-charging. The rectifier current increases smoothly until, at  $L$ , tubes 4, 5 and 6 are passing full current. The time delay before the rectifier passes full current is only 3 to 6 cycles, but this is enough to cushion the current inrush each time the capacitor is recharged for another welding operation.

This same gradual increase of current occurs when the capacitors are charged for the first time. During the 5-min time delay after  $SW1$  is closed,  $CR3$  is energized and its contact is open between points 90 and 99. However, Fig. 30A shows a normally-closed contact of  $L$  connected between these same points. This  $L$  contact is closed during the warming period, keeping point 90 at negative potential. When the "Charge" button is pressed, picking up  $L$  and closing the power circuit to the rectifier, the n-c contact of  $L$  disconnects 90 and 99, but capacitor  $C9$  delays the rise of rectifier grid voltage, so that the rectifier current increases gradually.

**30-10. Summary.**—The rectifier grid circuits have now been described, as shown in Fig. 30A. Because of these circuits, the rectifier smoothly charges the capacitors to the voltage selected by  $P1$ , and then trickle-charges them until the operator presses the foot switch to start the weld. As shown in the previous chapter and Figs. 29C and 29D,  $FS$  energizes  $CR1$ ;  $CR1$  picks up  $CR2$ .  $CR2$  picks up contactor  $D1$  or  $D2$  and energizes the sole-

noid valve, bringing the welder electrodes together. As the electrodes squeeze onto the work, the welder firing switch drops out *CR3* (if proper capacitor voltage lets tube 12 pick up *UVR*). Dropping out, *CR3* locks out the rectifier, opens the short circuit from across the welding transformer primary (starts the *TD5* hold timer) and starts the flow of welding current by letting *C14* discharge into *T19P*, whose secondary fires tubes 15 and 14, completing the circuit whereby the main capacitors discharge their stored energy into the welding transformer, making the weld. As the capacitor voltage decreases to zero and then reverses, current stops flowing through tubes 15 and 14, but tubes 17 and 16 by-pass the remaining welder current. At the end of the hold time, *TD5* drops out *CR1*, which picks up *CR3*. *CR3* short-circuits the welding transformer primary and permits the rectifier to pass current to charge the capacitors ready for the next weld. *CR1* also drops out *CR2*, which drops out contactor *D1* or *D2* and the solenoid valve, letting the electrodes separate.



## INDEX

### A

- A-c curve, 7
- Ammeter, 53
- Ampere, 10
- Amperes rms, 40
- Analyzer, 52
- Annular cable, 135, 137
- Anode, 15, 66
- Anode current, 66
- Arc drop, 18, 30, 92
  - in voltage-regulator tube, 377
- Askarel, 132
- Automatic weld timer, 93-114
- Autotransformer, 116
- Averaging time, 45, 48

### B

- Balloon, like a capacitor, 70, 211
- Bell ringer, 51
- Bias, grid, 181
  - negative, 85
  - by Rectox, 193
- Blower for controls, 309
- Blue light in tube, 91
- Bus, 137
- Buttons on timing chain, 275, 278

### C

- Cable, annular, 135
  - concentric, 136
  - size of, 24, 134
  - for welders, 136
- Capacitance, 145*n.*
- Capacitor, 69
  - on a.c. or d.c., 70, 72
  - a-c controls used with, 303-317
  - across coil or contacts, 79, 80
  - discharging the, 74

- Capacitor, energy storage in, 320
  - in filter, 170
  - grid-to-cathode, 105
  - ohms, 305*n.*
  - series, 140, 303-317
  - in timing control, 104
  - used with welders, 139
- Capacitor-storage welding, 327, 354
- Cathode, 15, 89
- Cathode-ray oscilloscope, 55
- Chain type seam-welding control, 271, 278
- Changing heat control during weld, 234
- Changing weld current and heat, 200
- Chart, 37
- Checking equipment and connections, 241
- Circular mil, 134*n.*
- Cleaning tubes, 34
- Compensator, 235
- Condenser (*see* Capacitor)
- Connection diagram, 63
- Contact, ignitron or magnetic, 4
- Contacts, n-o or n-c, 22
- Cool time, 107
- Cool-time relay, 112
- Copper oxide rectifier, 17, 28, 194
- Counting circuit, 299
- Crest voltage, 72*n.*
- Critical voltage, 85*n.*
- Current, 10
  - through a thyatron, 84
- Curve, a-c, 7
- Cycle, 6
  - counting, 58
  - recorder, 54
- CR7503 G.E. controls:
  - A100, -A109, 191
  - A104, 191, 233
  - A106, 233, 307, 308, 313

## CR7503 G.E. controls:

- A124, 155, 243
- A125, 220, 246
- B3, -B4, 271
- B7, 191
- B11, 191, 234
- B102, 271
- B106, 308, 310
- B110, 281, 282
- C103, -C107, 289
- C106, 307
- D116, -D137, 204, 250
- E (see Ignitron contactor)
- F118, 98, 99, 102
- F125, 237
- H120, 354, 356
- J107, 340

## D

- D.c., 6*n.*, 8
- D-c supply, 167, 171
- Deionization time, 89
- Demand current, 40
- Direction of electron flow, 88
- Discharge resistor, 24
- Discovery of vacuum tube, 65
- Divider, voltage, 68, 172
- Drain, water, 25
- Duty, per cent, 42, 46, 47

## E

- Edison effect, 66
- Electrodes, 261, 262
- Electron emission, 90
- Electron tube, 15
- Electrons, 15, 86
- Elementary diagram, 64
- Energy, pressure vs. motion, 323
  - storage, examples of, 319
    - in capacitors, 320
    - in inductance, 322
    - in a speeding truck, 324
- Energy-storage welding, 140, 318
- Erratic time delay, 125
- Excess stroke, 352

## F

- Feed-back transformer, 183
- Filter, resonance, 213
- Filtering, 169
- Firing switch, 335
- Flow switch, water, quick-acting, 20
  - thermal, 19, 164
- Flux, in transformer, 229
- Flying contact, 281
- Formula for per cent duty, 47
- Fuse, 11
  - line, size of, 241
  - starter, 18

## G

- G.E. welding controls:
  - for Sciaky process, 340
  - for seam welding, 270-302
  - for stored-energy welding, 354-383
    - (See CR-7503)
- Generator sets for welding, 138
- Good voltage for welders, 129-140
- Good welds, 141-151
- Grid, 67
  - negative, 87
  - shield, 90
- Grid bias, 181
- Grid circuits in heat controls 205
- Grid control of firing thyratrons, 179
- Grid rectification, 76
- Ground, 33, 118*n.*, 259

## H

- Heat, from electricity, 11
  - in a weld, 11, 141
- Heat control, phase shift, 203
  - advantages, 213
  - double-range, 232
  - proper use of, 214
  - with spot welder control, 220, 228
- Heat time, 107
- Heated tubes, 81
- High-voltage (2300 v.) controls, 307
- Hi-wave, Taylor-Winfield, 327
- Hold-off voltage, 182
- Hold time, 95

- I
- Igniter, 15  
 protecting the, 17  
 Igniter resistance, 32, 34  
 Ignitron, construction of, 16  
 firing the, 174-183  
 handling of, 25  
 Ignitron contactor, 4, 14-22  
 circuit of, 16  
 ratings of, 42  
 Impedance, 132  
 In phase, 117  
 Inductance, 145*n.*  
 energy storage in, 322  
 Inspections, 251  
 Installing, the ignitron contactor, 23  
 the synchronous control, 240  
 Instruments, 51-60  
 Interleaved bus, 138  
 Interlocked welders, 131  
 Inverse parallel connection, 174  
 Ionized gas, 89
- K
- Kilo, 12  
 Kilowatt (kw), 11  
 Kva, 12
- L
- Leading tube, 180  
 Leading-tube-trailing-tube circuit,  
 179, 182, 222  
 Load, 34  
 to measure the, 44  
 large, 49  
 Locking the controls, 252  
 Logarithmic scale, 39
- M
- Magnetic contactor, 4  
 Magnetic oscillograph, 59  
 Magnetism left in transformer, 149  
 Maintaining the synchronous panel,  
 240-252
- Mercury, 15  
 Mercury button contact, 166  
 Micro-switch, 20  
 Microfarad, 69  
 Motor-driven chain for seam weld-  
 ing, 275  
 Motor generator set, 138  
 Mouse trap, 86  
 Mu f, 69
- N
- Negative bias, 182  
 by Rectox, 193  
 Neon glow lamp, 7*n.*  
 Nonheat, 93*n.*  
 N-c, n-o, 22  
 Normally closed contacts, 22
- O
- "Octal" socket, 65*n.*  
 Off time, 96  
 Ohm, 10  
 Ohmmeter, 52  
 Ohms, capacitor, 305*n.*, 315  
 Oscilloscope, 31, 55  
 features of, 56  
 use of, 58, 257  
 Out of phase, 117  
 Overloaded tubes, 48
- P
- Peaker, peaking transformer, 186,  
 231, 232  
 Per cent duty, 42, 46  
 Phanotron, 82  
 Phase-shift diagrams, 208  
 Phase-shift heat control, 203  
 Phase-shifted ignitrons, rating of,  
 217  
 Phase-shifted power circuit, 224,  
 276, 310  
 Phase-shifting, the three-tube recti-  
 fier, 344  
 the six-tube rectifier, 372  
 Pi filter, 170



Plate (*see* Anode)

Pointer-stop meter, 53

Potentiometer, 68

Power, 11

Power circuit, 176  
using series capacitors, 303

Power factor, 144

Pressure switch, 95

Primary winding, 116

Program welding, 281

Pulsation welding, 106, 289, 298  
cautions regarding, 113

## R

Rating of ignitrons, 36

phase-shifted, 217

used with series capacitors, 307*n*.

Ratio, transformer, 333

Raytheon stored-energy control, 320

Reactance, 145

cable, 136

in filter, 170

Reactance peaker, 232

Reactor, 169

Reactor-storage welding, 339-353

Recorder, cycle, 54

weld, 235

Records, tube, 33, 252

Rectification, 66, 167

grid, 76

Rectifier, copper oxide, 28, 193,  
276

single phase, four tube, 327, 328

three phase, three tube, 341

six tube, 362

grid circuit of, 371

tube, 168

Rectox, 28, 193

Relay, telephone, 98*n*.

time-delay, 62

Resistance, 10

Resistance welding, 12

Resistor, 10

discharge, 24

Retractable head, 345

Rolls of seam welder, 280

## S

Safety circuit, 171

Saw-tooth waves, 198, 374

Saturated welder, 27

Schematic (*see* Elementary)

Sciaky welder, 320, 322, 339-353

Scope, 31

Seam welder, 2, 270

Seam welder control, all-tube, 281,  
289

high voltage, 308

with timing chain, 271, 308

Seam welding, speed, 280

with a spot-weld timer, 287

Secondary winding, 116

Selecting number of capacitors, 333,  
365

Sequence control, 93, 236

Series capacitors, 140, 303, 313

Short-time welds, 143

Sine wave, 56, 71*n*.

Socket, tube, 65

SP-11 Westinghouse control, 193

Spare tubes and parts, 128, 250

Spark coil, 32*n*.

Spark gap, 364

Speed of seam welding, 280

Spot welder, 1

Squeeze time, 94

Starter (*see* Igniter)

Starter-fuses, 18

Starting the tube control, 242

Stored energy welding, 318

controls for, 320

Symbol, 3

Synchronous controls, 152-383

used with capacitors, 307

Synchronous timing, 151, 152-161

Synchronous timing circuit, 184-199

## T

Taylor-Winfield Hi-wave control,  
320, 327-338

Telephone relay, 98*n*.

adjustment of, 127

- Time, averaging, 45  
 short, 6
- Time-delay relay, 61-80  
 5 min., 164
- Timer, automatic weld, 93-105
- Timing chain for seam weld, 275
- Timing the weld, 188
- Thermionic tubes, 81, 91
- Thermostat, 19
- Thyratron, 81-92  
 operating on d.c., 184, 283
- Thyrite, 24
- Trailing tube, 180, 182
- Transformer, 115  
 control, 157  
 current, 53  
 how it works, 228  
 peaking, 231  
 power, 132  
 turn ratio of, 333  
 voltage regulating, 329  
 welder, 4
- Transient current, 147  
 voltage drop caused by, 150
- Trickle charge, 331, 379
- Triode, 82
- Trouble, examples of correction of,  
 262  
 locating, 253-269  
 on weld timers, 122-128
- Tube, heated, 81  
 life and warranty of, 50  
 rating, 36  
 thyratron and vacuum, comparison of, 85  
 (*See also* Ignitron: Thyratron)
- Tube trouble, 255
- Two-stage footswitch, 93*n*.
- V
- Vacuum tube, 85
- Variable pressure during weld, 348
- Vector diagram, 210
- Volt, 10
- Volt ampere, 12
- Voltage, 129  
 in phase-shifted tube circuit, 215  
 poor conditions of, 259  
 across a resistor, 173  
 selecting, 133  
 across a thyratron, 92
- Voltage divider, 68, 172
- Voltage-inspector circuit, 380
- Voltage-regulating transformer, 329
- Voltage-regulator tube, 377
- Voltage wave, 143
- Voltmeter, 52  
 on capacitor-discharge controls,  
 332, 364
- W
- Warming of tubes, 91
- Water, connections for, 2.  
 quantity required, 44
- Water flow switches, 18
- Weld heat, 141
- Weld interval, 107
- Weld recorder, 235
- Weld time, 95
- Welding, limited by power supply,  
 138  
 operation, 260  
 with series capacitors, 313  
 of special metals, 141  
 with stored energy, 318
- Weld-O-Trol, 5
- Weltronic, automatic weld-timer  
 115-121  
 stored-energy control, 320  
 synchronous welder timer, 196
- Westinghouse, spot welder control,  
 193  
 stored-energy control, 320





## DATE OF ISSUE

This book must be returned  
within 3, 7, 14 days of its issue. A  
fine of ONE ANNA per day will  
be charged if the book is overdue.

---

