

Birla Central Library

PILANI (Rajasthan)

Class No :- 661.1

Book No :- B137 I

Accession No :- 37890

Acc. No.

ISSUE LABEL

Not later than the latest date stamped below.

--	--	--

CHEMICAL ENGINEERING SERIES

INORGANIC
CHEMICAL TECHNOLOGY

*The quality of the material used in the manufacture
of this book is governed by continued postwar shortages.*

McGRAW-HILL CHEMICAL ENGINEERING SERIES

Texts and Reference Works Outlined by the Following Committee

- | | |
|-----------------------------------------------------------------------------------------------|------------------------------------------------------------------------------------------------------|
| S. D. KIRKPATRICK, <i>Consulting Editor</i> · Editor,
Chemical Engineering | ALBERT E. MARSHALL · President, Rumford
Chemical Works |
| H. C. FARMELLE · Editor Emeritus Engineer-
ing and Mining Journal | R. S. McBRIDE · Consulting Chemical Engineer |
| HARRY A. CURTIS · Dean of Engineering, Uni-
versity of Missouri | C. M. A. STINE · Director, E. I. du Pont de
Nemours & Co. |
| J. V. N. DORR · President, The Dorr Company | E. R. WEIDLEIN · Director, Mellon Institute of
Industrial Research |
| A. W. HIXSON · Executive Officer, Department
of Chemical Engineering, Columbia University | M. C. WHITAKER · Director, American Cyan-
amid Company |
| J. H. JAMES · Professor Emeritus of Chemical
Engineering, Carnegie Institute of Technology | A. H. WHITE · Professor Emeritus of Chemical
Engineering, University of Michigan |
| W. K. LEWIS · Professor of Chemical Engineer-
ing, Massachusetts Institute of Technology | WALTER G. WHITMAN · Professor of Chem-
ical Engineering, Massachusetts Institute of
Technology |
-

THE SERIES

- BADGER AND BAKER—*Inorganic Chemical Technology*
BADGER AND McCABE—*Elements of Chemical Engineering*
CLARKE—*Manual for Process Engineering Calculations*
DAVIS—*Chemical Engineering Nomographs*
DODGE—*Chemical Engineering Thermodynamics*
EDWARDS, FRARY AND JEFFRIES—*The Aluminum Industry (in Two Volumes):
Aluminum and Its Production; Aluminum Products and Their Fabrication*
GRISWOLD—*Fuels, Combustion, and Furnaces*
GROGGINS—*Unit Processes in Organic Synthesis*
LEWIS AND RADASCH—*Industrial Stoichiometry*
MANTELL—*Adsorption*
MANTELL—*Industrial Electrochemistry*
NELSON—*Petroleum Refinery Engineering*
PERRY (EDITOR)—*Chemical Engineers' Handbook*
PIERCE—*Chemical Engineering for Production Supervision*
RHODES, F. H.—*Technical Report Writing*
RHODES, T. J.—*Industrial Instruments for Measurement and Control*
SHERWOOD—*Absorption and Extraction*
SHERWOOD AND REED—*Applied Mathematics in Chemical Engineering*
SHREVE—*The Chemical Process Industries*
TYLER—*Chemical Engineering Economics*
VILBRANDT—*Chemical Engineering Plant Design*
WALKER, LEWIS, McADAMS AND GILLILAND—*Principles of Chemical Engineering*
WINDING AND HASCHE—*Plastics, Theory and Practice*
-

CHEMICAL ENGINEERING SERIES

INORGANIC CHEMICAL TECHNOLOGY

BY

W. L. BADGER

Manager, Consulting Engineering Division, The Dow Chemical Co.

AND

E. M. BAKER

Professor of Chemical Engineering, University of Michigan

SECOND EDITION
SEVENTH IMPRESSION

McGRAW-HILL BOOK COMPANY, INC.
NEW YORK AND LONDON
1941

INORGANIC CHEMICAL TECHNOLOGY

COPYRIGHT, 1928, 1941, BY THE
MCGRAW-HILL BOOK COMPANY, INC.

PRINTED IN THE UNITED STATES OF AMERICA

*All rights reserved. This book, or
parts thereof, may not be reproduced
in any form without permission of
the publishers.*

PREFACE TO THE SECOND EDITION

Changes in inorganic technology in the last decade have been so rapid that much of the practice described in the first edition of this book has become obsolete, or at least partly replaced by newer processes. It has been necessary, therefore, to rewrite much of the subject matter of the text, although the philosophy of the book is still the same as in the first edition.

As before, we have attempted to write a textbook, not a handbook. We have also written the book very largely on the assumption that the student has not yet studied unit operations. Strictly speaking, this should mean that every piece of equipment mentioned should be described. This would, however, not only greatly increase the bulk of this book but would duplicate information easily available elsewhere. If the student does not understand what is meant when certain types of equipment are referred to in this text without a description, he should refer to such works as Perry's "Chemical Engineers' Handbook," or Badger and McCabe's "Elements of Chemical Engineering."

We wish to repeat that this book must be looked upon not as a handbook but as an outline or abstract of the subject matter. As in the first edition, references are still intended as a guide to collateral reading. For the proper use of this book as a text, the subject matter should be amplified by the instructor, either from the literature or, preferably, from his own experience.

Where a process described in the first edition is described very briefly or omitted entirely in this edition, it means that to the best of our knowledge the process is either not now used or has an importance secondary to the processes that are described. It is obvious that we cannot of our own experience be sufficiently familiar with all the fields covered by this book to be able to speak *ex cathedra* on current practice in all of them. Consequently, in some fields we have had to depend on the literature;

and if in these cases we have erred in not properly giving present practice, it is because the literature has not given us sufficient guidance.

About a third of the illustrations in this edition are new, and for these we wish to cite again the skill of Mr. P. A. Badger in preparing this type of drawing.

W. L. BADGER,
E. M. BAKER.

ANN ARBOR, MICHIGAN,
September, 1941.

PREFACE TO THE FIRST EDITION

This book is the outgrowth of several years' experience in teaching a course in the technology of the heavy chemical industries. The only books available were either too detailed, or did not represent current American practice. Further, most of the books written in the past have been written from the standpoint of the industrial chemist, and we desired to present the work from the standpoint of the engineer.

This book is intended primarily as a textbook, and this will explain many of its apparent shortcomings. Because of the limited amount of time given to this subject matter in most colleges, we have not considered it desirable to present each subject in great detail or to go into the minutiae of either operation or design. Some of the discussions may seem unnecessarily elementary to one who is familiar with these processes, but we have tried to write the book for the student who has no background of practical experience or previous contact with any of these processes. Nevertheless, we hope that, since we have included much information not available in any handbooks, and in some cases not discussed in the literature at all, the book will not be without interest to the chemical engineer who is already active in his profession.

We have attempted to describe current American practice, so far as we have been able to determine what that practice is. Obsolete processes have been mentioned only where they are of special historical interest; and, in general, no notice has been taken of processes which are not operated in the United States, with the exception of the Haber process for ammonia synthesis and the extraction of Chilean nitrate. The reason for the inclusion of the first is obvious, and the second was included because it furnished an excellent example of fractional crystallization for which the necessary data were available.

We have attempted to present the various processes in the light of present-day understanding of unit operations. In other words, we are trying to write from the chemical engineer's point

of view. We have tried to make the discussion of these operations sufficiently complete so that it will not be wholly unintelligible to the student who is not yet acquainted with them; but it will be of assistance if the reader is already familiar with the general theory. In fact, it is still an open question in our minds as to whether or not the unit operations can best be discussed before the student has any idea of the processes in which they are to be used and the ends which they are to accomplish.

The literature references which have been given are also an outgrowth of the fact that this is intended as a textbook and not as a handbook. The references are in no sense a complete citation of the authority for all of our statements. As a matter of fact, in relatively few cases do our references have this purpose. Most of the references are included with the idea that they form a parallel course of collateral reading to amplify and extend the subject matter of the text. Consequently, although most of the references are appended to a particular point in the text, they generally cover not only that particular point, but much of the whole process which is under discussion.

We have found that the student does not thoroughly master the theory here discussed without the actual solution of numerical problems. Consequently, a few such are appended to each chapter, but these are intended to be merely illustrative, and it is expected that the instructor who uses the book will make many similar problems of his own. For this reason, the problems have not been made numerous.

It is impossible for us to acknowledge specifically all the contributions that have been made to the writing of this book. Many individuals and corporations have supplied information without which the work would be a very faulty picture of present practice. To all of these friends we wish to express our sincere thanks. We also acknowledge especially the work of Mr. P. A. Badger, who has prepared all of the illustrations.

W. L. BADGER,
E. M. BAKER.

ANN ARBOR, MICHIGAN,
October, 1928.

CONTENTS

	PAGE
PREFACE TO THE SECOND EDITION	v
PREFACE TO THE FIRST EDITION	vii
CHAPTER	
I. INTRODUCTION	1
II. COMMON SALT	6
Production, 7; Grades, 8; Origin of deposits, 8; Salt deposits in the United States, 9; METHODS OF PRODUCTION, 10; Mining, 10; Solar evaporation, 11; Brines for evaporation processes, 12; Brine treatment, 13; THE GRAINER PROCESS, 15; Rates of evaporation, 17; VACUUM EVAPORATION, 19; Methods of feeding and salt removal, 22; Capacity of evaporators, 23; THE ALBERGER PROCESS, 26; Alberger flow sheet, 26; Structure of Alberger salt, 31; Drying and screening, 31; RELATIVE STATUS OF PROCESSES, 32.	
III. SULFURIC ACID	37
Production and distribution, 37; RAW MATERIALS, 39; Sulfur, 39; Pyrites, 42; Other raw materials, 42; CHAMBER PROCESS, 43; Sulfur burners, 44; Pyrite burners, 46; Burner gas, 49; Niter supply, 49; Dust collectors, 50; The Glover tower, 50; Lead chambers, 53; Chamber construction, 55; Gay-Lussac tower, 57; Movement of gases, 58; Transportation of acid, 58; Coolers, 58; Special systems, 58; Purification of sulfuric acid, 59; CONCENTRATION OF SULFURIC ACID, 59; Sludge acid concentration, 62; THE CONTACT PROCESS, 64; Theory of the contact process, 64; Rate of reaction, 66; Sulfur contact plant, 66; Pyrites contact plants, 69; Heat-transfer system, 70; Catalysts, 70; Converters, 72; Absorption systems, 72.	
IV. FIXED NITROGEN AND NITRIC ACID	76
SODIUM NITRATE, 77; Recovery of sodium nitrate from caliche, 78; NITRIC ACID, 79; Nitric acid from saltpeter, 80; Retorts, 82; Condensing system, 84; Recovery of nitrogen oxides, 85; AMMONIA, 85; Production and consumption of ammonia, 86; Synthesis of ammonia, 86; Theory of ammonia synthesis, 88; Catalysts, 90; Preparation of nitrogen and hydrogen, 91; Catalyst bombs, 95; Ammonia recovery, 96; Modifications, 97; NITRIC ACID BY AMMONIA OXIDATION, 98; Equilibrium in ammonia oxidation, 98; Preparation of gas mixture, 99; Con-	

CHAPTER	PAGE
verter construction, 100; Recovery system, 101; Construction of absorption towers, 102; Pressure system, 103; Concentration of nitric acid, 105; CYANAMIDE PROCESS , 105; Manufacture of calcium carbide, 106; Manufacture of calcium cyanamide, 106.	
V. HYDROCHLORIC AND PHOSPHORIC ACIDS.	111
HYDROCHLORIC ACID , 111; Manufacture from salt, 111; Salt-cake furnaces, 112; Theory of absorption, 116; Absorption systems, 121; Synthetic hydrochloric acid, 124; By-product hydrochloric acid, 126; PHOSPHORIC ACID , 127; Sulfuric acid method, 127; Electric-furnace process, 131; Blast furnace process, 132.	
VI. SODIUM CARBONATE	135
Production and distribution, 135; Grades, 136; Development of the soda processes, 136; LEBLANC PROCESS , 137; SOLVAY PROCESS , 139; Flow sheet, 140; Operation of the Solvay process, 143.	
VII. CAUSTIC SODA AND CHLORINE.	150
Production and distribution, 150; CHEMICAL CAUSTIC , 151; Flow sheet, 151; Chemical theory, 153; Dorr causticizing plant, 154; Small discontinuous plants, 158; Evaporation, 158; ELECTROLYTIC CAUSTIC , 159; Flow sheet, 159; Chemical theory, 161; The diaphragm, 163; Current efficiency, 164; Voltage efficiency and energy efficiency, 165; Brine supply, 166; Cells, 166; Mercury cells, 169; Operation and control of diaphragm cells, 170; Evaporation of electrolytic caustic solutions, 172; Purification of caustic, 182; Caustic pots, 183; Relative importance of chemical and electrolytic caustic, 185; CHLORINE , 185; Bleaching powder, 186; LIQUID CHLORINE , 188; Production and distribution, 188; Theory, 188; Drying equipment, 190; Compressors, 190; Refrigeration, 190; Receivers, 191.	
VIII. MISCELLANEOUS PRODUCTS	194
ALUM , 194; Production and uses, 194; Methods of manufacture, 195; COPPERAS , 196; Methods of manufacture, 196; COPPER SULFATE , 197; SODIUM SULFATES , 197; HYP , 199; EPSOM SALTS AND MAGNESIUM CHLORIDE , 199; ACID PHOSPHATE , 201; Chemical theory, 201; Plant, 202; Concentrated fertilizers, 202; TRISODIUM PHOSPHATE , 203; POTASSIUM SALTS , 206; German and French potash, 207; Searles Lake process, 207; New Mexico processes, 208; The system sodium chloride-potassium chloride-water, 209; Recovery of potassium chloride, Crystallization process, 213; Flotation process, 213; BORAX ,	

CONTENTS

xi

PAGE

**213; CALCIUM CHLORIDE, 214; BROMINE, 215; CARBON DIOX-
IDE, 217; Chemical theory, 218; Plant, 218.**

APPENDIX. 223

Boiling points of salt solutions, 223; Properties of Saturated
Steam, 224; Dimensions of Standard Iron Pipe, 225; Density
and Specific Gravity of Solutions Heavier than Water, 226;
Specific Gravity and Density for Liquids Lighter than Water,
228; Properties of Sodium Chloride Solutions, 229; Properties
of Electrolytic Caustic Solutions, 230.

INDEX. 231

INORGANIC CHEMICAL TECHNOLOGY

CHAPTER I

INTRODUCTION

Technology in general comprises those sequences of operations by which finished products are fabricated from raw materials. The term *mechanical technology* designates those operations in which the form of the material is altered, but not its chemical nature. Such operations, for instance, would be the conversion of wood into lumber, the conversion of steel ingots into plates and structural shapes, and the spinning and weaving of cotton fibre into textiles. *Chemical technology*, on the other hand, has to do with such operations as change the chemical nature of the substances involved. In contrast to the above mechanical operations there would be, within the category of chemical technology, the conversion of wood into paper pulp or charcoal, hardening and tempering steel or the conversion of scrap iron into copperas, the manufacture of rayon from cotton fiber, and similar operations. In many industries mechanical technology and chemical technology are so closely interlocked that they cannot be discussed separately. For instance, in the glass industry the manufacture of the raw glass from sand, lime, and soda is a chemical operation, but its fabrication into plate glass or blown shapes is mechanical. The manufacture of sugar consists largely of mechanical operations; since sugar exists as such in both the beet and the cane, and it is only necessary to extract it from the vegetable tissues and separate the impurities. These separations, however, can only be accomplished by chemical transformations; and the control of the process involves so much chemistry that the industry is usually, and rightly, thought of as a chemical industry. In fact, in almost no case can the chemical opera-

tions and the mechanical operations in even a limited part of any industry be entirely divorced from each other.

The operations of chemical technology are primarily the province of the chemical engineer. Chemical technology is a composite of many fields of knowledge, of which chemistry is only one although an extremely important one. Seventy-five years ago most of the industries which now fall in this field were already in existence in a highly developed state and were a necessary part of our industrial fabric. Although they antedate the development of chemical engineering, they had been slightly, if at all, touched by the chemist. These industries had evolved through generations or centuries of empirical experimentation, and represented in themselves highly specialized fields of knowledge. The introduction of a knowledge of chemistry served to improve them with respect to quality of product and cost of operation. In a few cases, such as the manufacture of dyes and of artificial silk, a whole new industry has been created by the work of the research chemist and the chemical engineer, but in general their efforts have merely improved and modified existing industries.

Since most of these industries are based, at least in part, on experience, it follows that, to serve these industries, the chemical engineer must be familiar with much of this background of experience which has been acquired empirically, it is true, but nevertheless worked out to a considerable degree of perfection. There are still in these industries many operations that can be only approximately analyzed or explained by the application of chemical theories, and many pieces of equipment whose design cannot be calculated by rigid engineering methods. Consequently, a discussion of chemical technology must embrace, not only chemical and engineering theory, but also historical background and established practices.

One is impressed by the fact that industrial progress is not always accomplished by the development of the chemistry of a process. Reactions that take place easily and simply in a beaker do not always take place in the same way on a large scale. The translation of laboratory research into terms of manufacturing processes lies in the field of chemical technology. The primary tools of the chemical engineer, therefore, must be a knowledge of the methods whereby operations may be performed on the manufacturing scale. These operations are often spoken of as the unit

operations. Typical of these are such operations as heating, evaporating, crystallizing, filtering, drying, distilling, absorbing, leaching, grinding, screening, and mixing. If a simple and arbitrary distinction between the chemist and the chemical engineer is desired, it may be found in the chemical engineer's knowledge of these unit operations, through which he may interpret the work of the chemist in terms of industrial production.

The engineer is further characterized by a commercial viewpoint, and in this sense may be distinguished from those scientists whose investigations need not necessarily show a profit. The engineer is the servant of industry, and industries cannot exist without financial returns. Irrespective of how perfect the theory of a process or the design of a piece of equipment may be, if in the long run the process or equipment cannot be made to operate profitably, there has been no engineering solution of the problem. The engineer, therefore, must have some knowledge of the economic and practical phases of manufacturing.

It is apparent that since the engineer must make his process pay, he must know something of markets where his product is to be sold and prices that may be obtained. He must know the sources of his raw materials. He must be able to decide whether to locate his plant near the source of supply or near the markets. He should know whether or not it is possible to expect an export trade or foreign competition, and in both cases he must know foreign markets, and import and export duties. He must be able to protect his ideas by patents; and he very often meets such problems as employment, pensions, insurance, safety devices, and profit-sharing ideas. Although these are a necessary part of the engineer's equipment they can only be suggested in this book, and some of them cannot be touched. It is, however, intended to illustrate some of the reasons for the success or failure of different processes for making the same product, and to indicate, in some cases, how the technology of a process is dictated by economic considerations.

Chemical technology as a whole may be divided roughly into inorganic and organic industries; but the division is not sharp, as there are many borderline industries. Certain of the inorganic industries, such as ceramics, glass, and portland cement are so largely self-contained that they form separate divisions of technology and do not fall within the scope of this book.

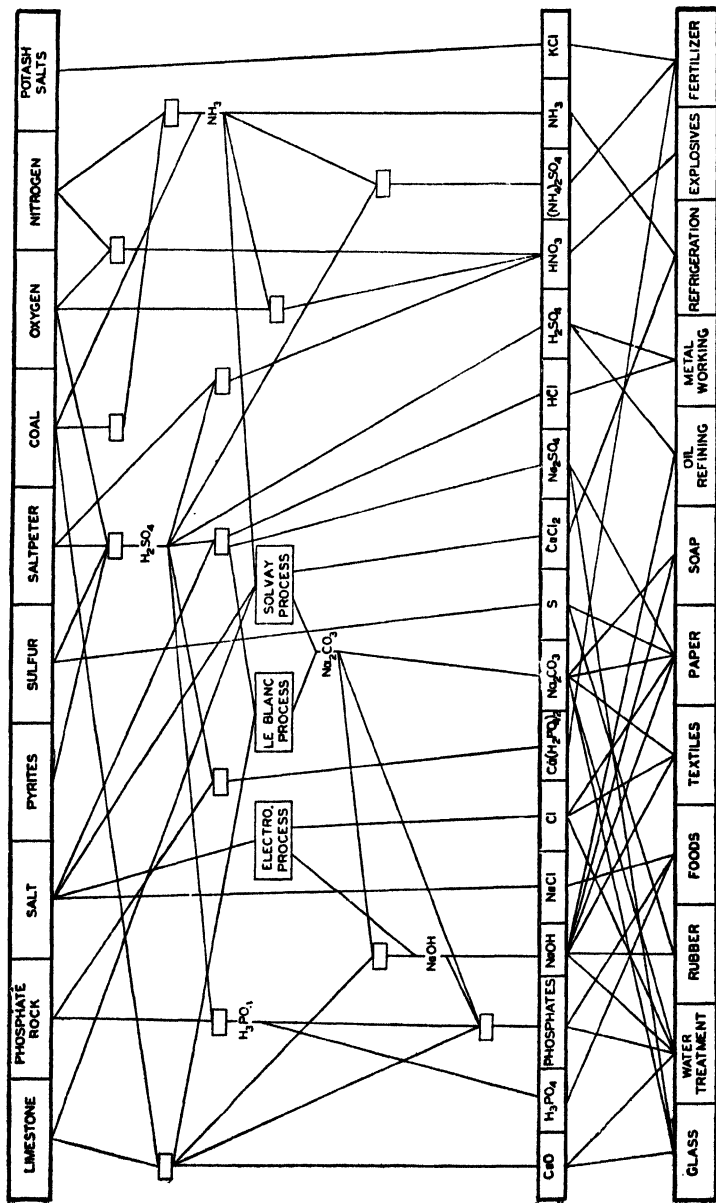

Fig. 1.—Interrelationships in the heavy chemical industries.

The manufacture of acids, alkalis, and salts forms the backbone of inorganic technology, and is usually known as the *heavy chemical* industry. A diagrammatic illustration of this industry and the interrelationships of its products are roughly shown in Fig. 1. At the top of the figure are natural raw materials. These are combined in many ways to form primary products, and these primary products may find markets as such or may be recombined to form a series of secondary products. The final form in which the products of the heavy chemical industry come onto the market is shown in the lower part of the diagram, while across the bottom appear the industries in which these products are consumed. The diagram is not complete, but enough interlocking is shown to illustrate the manifold interrelationships, and to show how the inorganic chemical industries are largely built on the three fundamental materials, common salt, sulfur, and limestone.

The two most important basic materials are salt and sulfuric acid. The technology of these two will be described first. The other acids will then be discussed and then the alkali industries, although it is obvious from Fig. 1 that a hard and fast division cannot be made. The alkalies lead naturally to chlorine; and finally a number of miscellaneous products will be described, which exhibit interesting applications of the unit operations, although in themselves they are not so important either in tonnage or value as most of the products previously discussed.

CHAPTER II

COMMON SALT

The manufacture of common salt is, without question, the oldest of the inorganic chemical industries. Its beginnings are lost in antiquity; and because of the wide distribution of salt in nature, the industry has developed all over the world. For centuries, deposits of salt or brines have been available that gave a product pure enough to satisfy the average non-critical user. The industry, therefore, has always been considered a very simple one. Within the last 25 years, the salt industry has discovered that there is a demand for more carefully specified products, and cheaper products, than it had been furnishing. At present, the demand is definitely not only for salt of high purity, but also for salt having particular crystal structures for particular uses.

The manufacture of sodium chloride is concerned mainly with the two unit operations of evaporation and crystallization. Besides these, however, the operations of drying, fluid transportation, and, in some cases, sedimentation, are of some importance. The result of a better understanding of the processes of heat transfer and evaporation has been a greatly increased capacity of certain types of salt-making equipment, the elimination of others which were not economical, and a steady decrease in the amount of fuel needed per ton of salt made. An understanding of the principles of crystallization is making it possible for the manufacturer to produce the type of grain demanded by users, with a greater certainty than ever before that the amount of each grade produced will correspond to the demands for that grade.

Besides the obvious use of salt for table and dairy purposes, and in the canning and packing industries, it is the basic material for the important industries making sodium carbonate and sodium hydroxide. These in turn are vital to the great industries of paper, glass, soap, and oil refining. From salt, also, is obtained chlorine, which is used in the paper and textile industries, in water purification, and in the manufacture of many organic chemicals.

Because salt is widely distributed, and because it can be made by a cheap and simple process, the margin between manufacturing cost and selling price is always small. Consequently, salt plants are located, so far as possible, near the points of consumption; and at least the common grades of salt are rarely shipped great distances. A product that can command a special price, either because of unusual purity or unusual grain structure, may thereby command enough margin between manufacturing cost and selling price to permit a greater shipping radius, thus making available much larger markets. Consequently, an application of the principles of chemical engineering, which will result in higher grade products, may result in disproportionately greater returns. Also, since the price of salt is fairly stable, that plant which by the application of sound engineering can produce more cheaply may likewise extend its markets.

Production.*—In 1938 the world's production of common salt was approximately 26,000,000 tons. Of this quantity, the United States produced 8,026,000 tons. The other countries whose production reached 1,000,000 tons or more were France, Germany, Russia, Great Britain, China, and India. In the United States, the 1939 production was 9,278,000 tons, of which Michigan produced 26.0 per cent, New York 22.0 per cent, Ohio 19.3 per cent. The remainder was produced largely in Louisiana, Kansas, California, and Texas.

The classification and value of the 1937 production by methods of manufacture were as follows:

TABLE I.—AMOUNT AND VALUE OF SALT PRODUCED BY METHODS OF MANUFACTURE, 1937

Method	Percentage of total	Value per ton
Salt in brine.....	49.5	0.40
Rock salt.....	21.5	3.20
Vacuum-pan salt.....	17.4	5.83
Open pans or grainers.....	5.4	8.46
Solar evaporation.....	4.2	3.59
Pressed blocks from evaporated salt.....	1.6	7.47
Pressed blocks from rock salt.....	0.4	6.70

* Production and distribution statistics in this book have been taken from government publications, *Mineral Industry*, and especially from *Chemical and Metallurgical Engineering*.

It is apparent from the above that 27.0 per cent of the 1939 production was made by evaporation processes. These groups represent the highest grades of salt.

Grades.—Bulk salt is usually known to the trade as *common fine* or *common coarse*, which represent, respectively, the product of vacuum pans or grainers. There may be also a distinction between No. 1 and No. 2 to indicate the color or appearance, salt that is decidedly dirty being classed as No. 2. Higher grades are usually marketed as flour, table, butter, or cheese salt. The distinction between these products is purely on the basis of size, but definite standards have never been established or generally accepted. Salt is sold in a variety of packages, from the standard barrel of 280 pounds net down to a 1½-pound sack or carton. The suitability of a given salt for any particular purpose depends not only upon its fineness and its appearance, but also upon its grain structure.

To improve the free-flowing qualities of salt for table use, about 1 per cent of finely pulverized inert material such as calcium phosphate or magnesia may be added, and salt so treated is marketed as shaker salt. Either table or shaker salt may also have added about 0.025 per cent of potassium iodide, and this product is sold as iodized salt.

Origin of Deposits.—Most salt beds have been formed by the evaporation of sea water. While sea water varies slightly in composition in different parts of the world, it contains approximately 3.7 per cent total solids of about the following composition:^{(1)*}

TABLE II.—COMPOSITION OF SOLIDS IN SEA WATER

	Per cent
NaCl.....	77.76
MgCl ₂	10.88
MgSO ₄	4.74
CaSO ₄	3.60
K ₂ SO ₄	2.46
CaCO ₃	0.34
MgBr ₂	0.22

If a body of ocean water were cut off by a bar or a change in the land surface under such conditions that evaporation exceeded rainfall, then the substances that it carried in solution would be

* Reference numbers in parentheses throughout the text refer to references at the end of each chapter.

deposited in the order in which the water became saturated with them.⁽²⁾ Sea water is nearly saturated with calcium carbonate and this would be the first material to deposit. It appears in the deposits in the form of limestone, often interspersed with layers of shale from a settling of suspended mud. In the usual course of evaporation, the next substances deposited would be calcium sulfate and sodium chloride; and these are often intimately associated, though they may appear as separate layers. If at intervals there was an inlet of additional sea water, layers of calcium carbonate may alternate with layers of salt. If the pool of sea water remained intact until evaporation proceeded to dryness, increasing amounts of calcium and magnesium chlorides would appear in the upper layers of salt; and finally, at the end of the process, a product rich in potassium chloride would be deposited. Many double salts are possible and are found in the deposits as a result of various intermediate stages in the evaporation.

As a result of this process, the lowest beds of salt will generally be the purest. The upper layers will be increasingly impure; and in some small area, probably near the center of the original basin, there may be a deposit consisting mainly of potassium and magnesium salts. On the other hand, the last brine from which the potassium and magnesium salts could be deposited would be relatively small in amount, and therefore might easily have been washed away or distributed in small scattered pools. Known potash deposits have been formed by the evaporation of these residual brines, but the potash that accompanied salt found in most parts of the world has not yet been located.)

Salt Deposits in the United States.⁽³⁾—The most important single salt deposit in the United States is a large bed that extends more or less continuously under western New York, northern Ohio, southwestern Ontario, and most of Michigan. It varies greatly in thickness and purity and disappears at many points, but is nearly continuous in one form or another throughout this region.

A second important salt-producing area is found in southeastern Ohio and West Virginia on both sides of the Ohio River. In this area, salt does not appear as rock salt, but in the form of natural brines which are dilute and rather impure. A third area is represented by a large deposit of rock salt in central Kansas and northern Oklahoma. There are many small scattered salt

deposits through the mountain districts, especially in the southwest, but they can hardly be said to represent commercially important sources.

A peculiar occurrence of salt is found in the coastal plains of Louisiana and Texas. These deposits are marked on the surface by domes or slight elevations, several acres in extent. Under these domes are found vertical plugs of rock salt of rather limited area and of great but unknown depth. The salt extends to within a few hundred feet of the surface of the ground. It is very pure, analyses showing over 99.8 per cent NaCl in place.⁽⁴⁾

The origin of these plugs has never been satisfactorily explained. The most reasonable hypothesis is that the salt has been forced up from below due to the increase in volume that occurs when fused salt crystallizes.^(5,6) The fact that the surrounding strata are tipped up toward the plug on all sides supports this hypothesis. Another indication that the salt originally came from fused material is its high purity and the absence of calcium sulfate, calcium carbonate, or such stratification in structure as is always associated with deposits formed by crystallization from solution.

METHODS OF PRODUCTION

The methods by which marketable salt is produced may be classified as follows:

1. Mining.
2. Solar evaporation.
3. Evaporation by artificial heat.
 - a. Direct-fired pans or kettles (obsolete).
 - b. Grainers.
 - c. Vacuum evaporators.
 - d. Alberger process.

Mining.—Where coarse salt of moderate purity will meet the demands of the trade, mining is the most satisfactory method of recovery. In New York, Michigan, and Kansas, this gives a salt less pure than evaporated salt and usually decidedly gray in color. The salt is used for cattle, for ice cream manufacture, for salting hides, and for any uses that demand a grain much over $\frac{1}{8}$ inch in diameter. In Louisiana, because of the high purity of the deposits, mined salt may be crushed fine and used for table and dairy salt. In general, the higher grades are made by one of the evaporation processes. Salt-mining methods do not differ

greatly from ordinary mining methods. In Louisiana, however, the rooms are 60 feet wide and 30 to 60 feet high.

Solar Evaporation.—Solar evaporation is practical in districts where the evaporation exceeds the precipitation. Table III shows typical conditions in the neighborhood of San Francisco Bay.⁽⁷⁾

TABLE III.—TYPICAL RAINFALL AND EVAPORATION, IN INCHES, SAN FRANCISCO BAY, CALIFORNIA

Month	Rainfall, inches	Evaporation, inches
April.....	1.36	3.38
May.....	1.14	5.31
June.....	0.67	6.62
July.....	0.00	7.81
August.....	0.00	7.81
September.....	0.00	4.94
October.....	0.77	2.94

An evaporation of 1 inch means the evaporation of 113 tons of water per acre. This cheap evaporation furnishes the only feasible method for manufacturing salt from sea water in the United States. At present, salt is made by solar evaporation at San Diego, around San Francisco Bay, and at Great Salt Lake in Utah. Solar evaporation as carried out in New York State, which has been mentioned in many handbooks, is now entirely obsolete.

The method of operation around San Francisco is typical of present practice. Sea water is admitted to large storage ponds at high tide. From these storage ponds, in which some evaporation takes place, it is elevated by pumps, sometimes operated by windmills, to another pond from which it flows to the rest of the system by gravity. The area of the ponds at any one plant may be from 500 to 2,000 acres. In the first evaporating ponds, the brine is concentrated to about 25°Bé.,* and most of the calcium sulfate is deposited. When salt crystals begin to form, the brine is run into the crystallizing ponds. Salt separates in these ponds as evaporation continues and the concen-

* For an explanation of the Baumé scale for specific gravities, see Appendix, Tables XXVIII and XXIX.

tration of calcium and magnesium chlorides in the mother liquor steadily increases. These salts are more soluble than sodium chloride and give solutions of greater density. The mother liquor is usually discarded when the density in these ponds is from 29 to 32°Bé. These mother liquors may contain 300 to 400 grams per liter of solids, the composition of which may vary within wide limits. Table IV shows the maximum and minimum figures from six typical bitterns.

TABLE IV.—RANGE OF ANALYSES OF TOTAL SOLIDS IN SOLAR BITTERNS

	Per cent
NaCl.....	6 to 60
KCl.....	5 to 10
MgCl ₂	20 to 60
CaSO ₄	0.5 to 2.0
MgSO ₄	10 to 25
MgBr ₂	0.6 to 1.0

Occasionally these bitterns are worked for magnesium chloride and bromine but usually they are wasted.

At the end of the season, the crystallizing ponds are drained and the salt is harvested by hand or by machinery. It is usually stacked in large piles and then reclaimed from these piles for a rough purification. This consists in a preliminary crushing, washing with salt brine, and further storage for drying. This process does not make table or dairy salt. When these grades are desired, this salt is dissolved and the solution evaporated in vacuum evaporators.

Brines for Evaporation Processes.—In the Ohio–West Virginia district, and in the Saginaw Valley of Michigan, evaporation processes are carried out on natural brines that are more or less dilute and impure. These salt industries exist because of protection by freight rates or because of valuable by-products. Most evaporated salt is made from artificial brines. These are prepared by pumping water down to a deposit of rock salt and recovering a practically saturated solution. Typical analyses of artificial brines from the Michigan districts are as shown in Table V⁽⁸⁾.

A typical salt well is shown in Fig. 2. It varies from 10 inches in diameter at the surface of the ground to 6 inches in diameter at the bottom. It is drilled some distance into the layer of salt which it is desired to work. The well is usually cased down to the

top of the bed; and this is especially necessary when the well passes through ground water, or through thin or impure layers of salt that are not to be worked. In the center of the well, a 3- or 3½-inch pipe is run to the bottom of the hole. Fresh water is pumped down the annular space, dissolves the salt, and is returned through the central pipe. When there is a single well in a single cavity, the brine may be lifted by the pressure of the water-supply pump. It is more general practice to introduce a jet of compressed air part way down in the central tube. The cavities formed at the base of these wells become very large. In some cases, wells half a mile apart are known to communicate

TABLE V.—COMPOSITION OF ARTIFICIAL SALT BRINES IN GRAMS PER LITER

	A	B	C	D
CaSO ₄	2.2	4.8	2.7	2.0
MgCl ₂	3.9	1.6	Trace	Trace
Na ₂ SO ₄	1.8	0.0	5.0	3.0
NaCl.....	284.1	303.6	303.6	305.9
KCl.....	Trace	Trace	Trace	Trace

A—Inland-Delray Salt Company, Delray, Mich.

B—Michigan Alkali Company, Wyandotte, Mich.

C—Diamond Crystal Salt Company, St. Clair, Mich.

D—Worcester Salt Company, Ecorse, Mich.

at the bottom. If several thin beds of salt separated by layers of rock were worked, trouble would be experienced from rock cracking off and crushing the central pipe. It is desirable, therefore, to isolate these upper layers and confine cavities so far as possible to a single stratum.

Brine Treatment.—Brines almost invariably contain traces of colloidal ferrous iron and hydrogen sulfide. On standing for some hours in open storage tanks the hydrogen sulfide escapes; and very often a small amount of lime is added in these tanks to precipitate or coagulate the iron. Frequently the calcium and magnesium salts are partly removed by treatment with lime and sodium carbonate, or with sodium carbonate and sodium hydroxide. It is rarely practical, because of the expense, to remove completely these impurities and therefore the usual treatment is only a partial one.

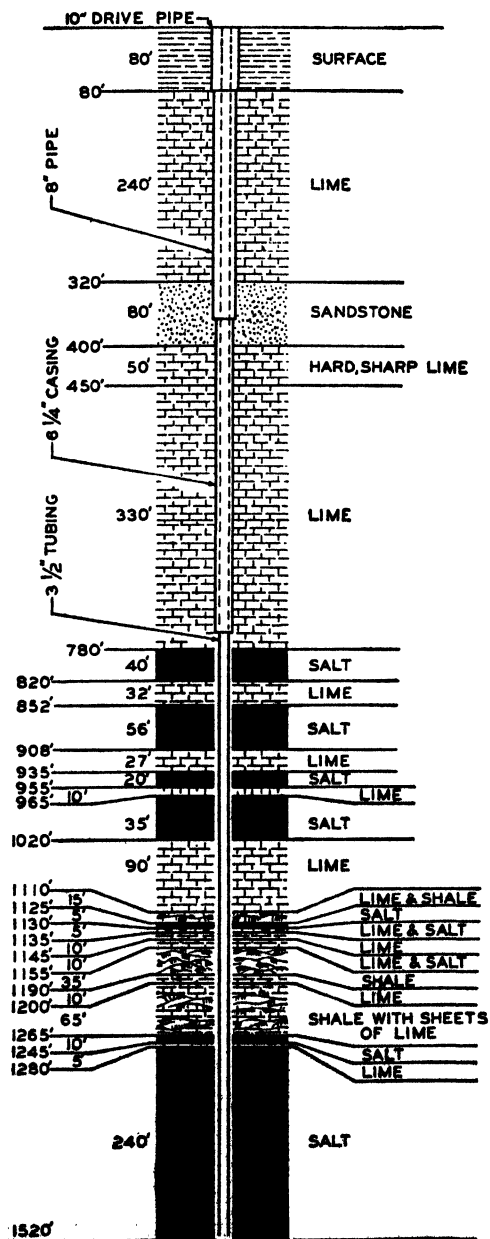

FIG. 2.—Section of salt well.

THE GRAINER PROCESS

The grainer process is characterized by the evaporation of brine in long shallow pans at temperatures below the boiling point. The ordinary grainer (Fig. 3) is a steel vessel, 100 to 150 feet long, 12 to 18 feet wide, 22 inches deep, filled with brine nearly to the top. A heating element is provided in the form of a number of passes of $3\frac{1}{2}$ - or 4-inch pipe, parallel to the long axis of the grainer. Below these coils is a system of reciprocating rakes.

A sliding framework of light angle-iron is carried on brackets which are riveted to the side of the grainer. Hinged scrapers are provided at 8- or 10-foot intervals. This whole framework is given a slow reciprocating motion by means of a hydraulic cylinder at one end of the grainer. The stroke of this cylinder is a little longer than the distance between scrapers, so that salt that settles to the bottom is gradually advanced to one end. At the discharge end, there is an inclined drain board; and the last panel of the rake is hinged so that the salt is pushed up on this drain board. Beyond the drain board is a conveyer which carries the salt to storage.

The characteristic feature of grainer operation is that the brine does not boil. Evaporation takes place only at the surface of the brine. Here microscopic crystal nuclei form, but they are prevented from sinking by the surface tension of the brine. Further deposition of salt will naturally occur most readily on these existing nuclei. These nuclei are cubes, the usual crystal form of sodium chloride. The part of the cube that is submerged is not in the zone of crystallization, and the top of the cube is not wet by the brine. Consequently, further growth can occur only around the upper edge of the original cube. This growth takes the form of a ring of roughly rectangular cross-section. This increased weight causes the mass to sink slightly but the increased circumference gives a greater supporting force. The result of this process of crystal formation is to build up a hollow square pyramid which floats on the surface point downward. Sooner or later chance disturbances cause these crystals to sink to the bottom and the process is repeated. Grainer salt, therefore, consists of these hopper crystals of varying sizes, usually more or less broken by the action of the rake. Consequently, this salt has a relatively large surface and a relatively open structure. Hoppers in ordinary grainer salt are rarely over $\frac{1}{8}$ inch across. Under special condi-

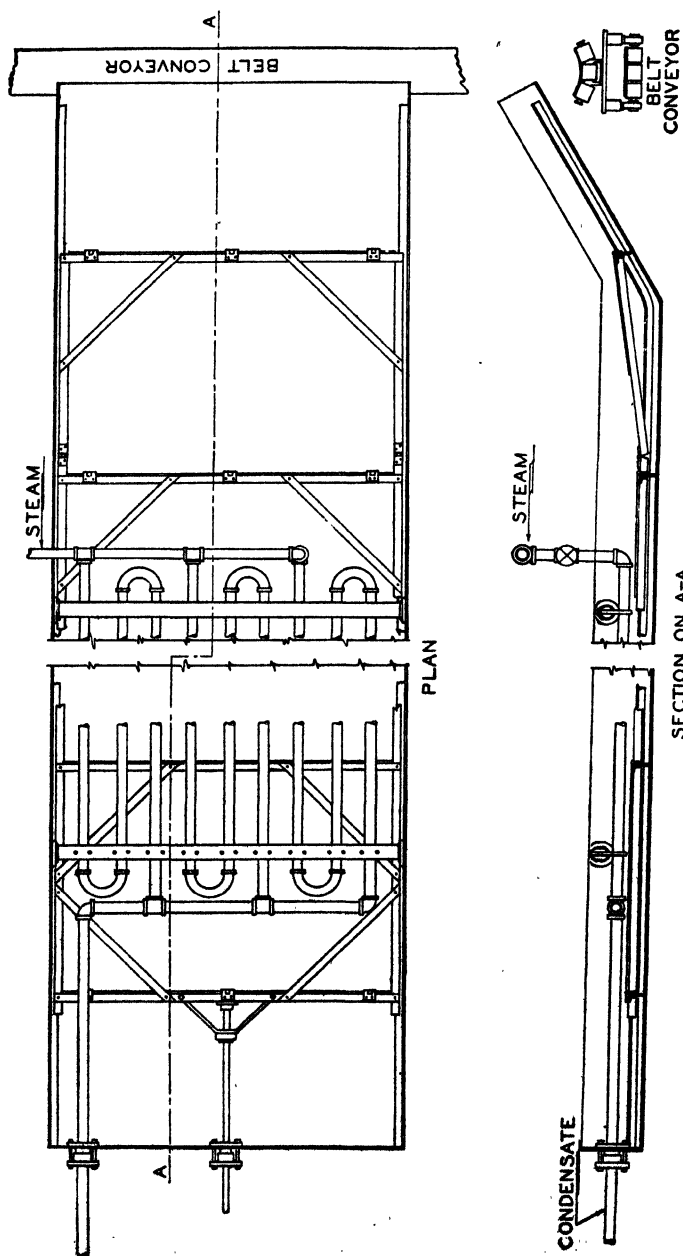

SECTION ON A-A
Fig. 3.—Salt grainer.

tions they may become larger, and may even reach the dimension of 1 inch on a side. Figure 4 shows a large hopper, and Fig. 5 a photomicrograph of grainer salt as packed.

Rates of Evaporation.—The temperature of the brine is one of the important features in grainer operation. It depends on the amount of heating surface provided per unit of evaporating surface. If there is a varying amount of heat loss by radiation this also will affect the brine temperature.

It depends further on the rate of heat transfer through the heating surface from steam on the one side to brine on the other. This rate of heat transfer is affected by all the factors that affect any case of heat transfer: such as the velocity of the steam, the free-

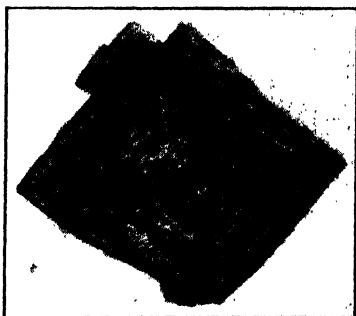

FIG. 4.—Hopper crystal of salt. (× 7.)



FIG. 5.—Coarse grainer salt. (× 10.)

dom of the coils from air, the completeness with which condensed water is drained from the coils, and the amount of scale on the

pipes. The brine is kept as still as possible, its only motion being the motion of convection currents in the neighborhood of the heating surface and the agitation due to the rakes; but these latter move so slowly that the upper layers of brine are not disturbed by them. Consequently, the resistance to heat transfer of the film on the brine side will be so great that conditions on the steam side should have practically no effect on the coefficient of heat transfer if the coil is reasonably well drained. In addition to this, scale which forms on the coils probably has more effect on the coefficient of heat transfer in the grainer than any other one factor. This scale may reach an actual thickness of from $\frac{1}{8}$ to $\frac{1}{2}$ inch before the grainer is shut down for cleaning and discarding impure bitters. The latter figure is probably the upper limit. Grainer coils are usually so proportioned that with steam at atmospheric pressure the brine is about 175°F., and with steam at 35 to 40 pounds the brine reaches 210 to 214°F. Typical heat transfer data may be found in Table VI.

The ordinary range of brine temperatures in grainers is from 140 to 214°F. When operated at as low as 140° a very coarse salt is made with grains up to $\frac{3}{8}$ inch across, called "packer's" salt, but the capacity of the grainer is reduced to 1 or 2 barrels

TABLE VI.—DATA FROM 24-HOUR GRAINER TEST

	A	B
Size of grainer, feet.....	18 by 150	18 by 150
Evaporating surface, square feet.....	2,700	2,700
Heating surface, square feet.....	1,993	2,015
Average temperature of brine entering, degrees Fahrenheit.....	155	140
Average temperature in the grainer, degrees Fahrenheit.....	177	189
Steam pressure, entrance to coils, pounds gage...	4.0	11.8
Steam pressure, exit of coils, pounds gage.....	3.0	10.7
Quality of steam at entrance, per cent.....	98.8	98.8
Temperature of condensate, degrees Fahrenheit..	220	245
Pounds wet salt made.....	29,100	36,000
Moisture in wet salt, per cent.....	19.8	19.7
Pounds dry salt made.....	23,338	28,908
Barrels of dry salt.....	83.3	106.4
Pounds of condensate removed.....	82,150	111,600
Coefficient of heat transfer.....	35.4	41.5

of 280 pounds per 24 hours per 100 square feet grainer surface. The ordinary grainer operates at 180 to 200°F. and makes a much finer salt, with a corresponding capacity of 3 or 4 barrels. If the temperature of the brine rises much above 214°, boiling is apt to occur in spots, and the brine is agitated enough to prevent hopper crystals forming.

Table VI gives the important data from a test of two grainers using different steam pressures. This shows plainly that higher steam pressures result in higher brine temperatures and more rapid evaporation. Part of the larger yield in Test *B* is, however, due to the higher heat transfer coefficient, which in turn is due to the fact that the coils of grainer *B* had less scale on them.

VACUUM EVAPORATION

By vacuum evaporation is understood the active boiling of brine in single or multiple effect evaporators of a standard type. Figure 6 shows the construction of a double-effect salt evaporator. The two bodies I and II are exactly alike. A cast-iron cylindrical shell *A* is closed at the top with a cover having a vapor outlet *B*, and at the bottom with a cone *C*. Extending completely across this body are two tube sheets, *D* and *E*. Between these tube sheets are expanded a number of tubes *F*. In the center a very much larger tube *G* is provided which is called the downtake. In normal operation, the evaporator is filled with brine to a level slightly above the top tube sheet and steam is admitted at *H*. The steam, therefore, surrounds the heating tubes and as it gives up its heat to them and is condensed, the condensate is removed through pipe *J* by a pump or trap. Air or other non-condensable gases which accompany the steam are removed by pipe *K*. Brine is fed through connection *L*. In a double effect, the vapors that are produced by the boiling brine in effect I pass over to effect II where they serve as the supply of heat for the second effect exactly as the original steam did in the first. Thus, slightly less than 2 pounds of water can be evaporated in the double effect for every pound of steam supplied at *H*.

The vapors leaving the second effect pass to the condenser *M* which is supplied with a large amount of cold water through connection *N*. This water cascades from one shelf to another, and as the vapor passes up through these cascades, it is condensed. The resulting mixture of cooling water and condensed vapor

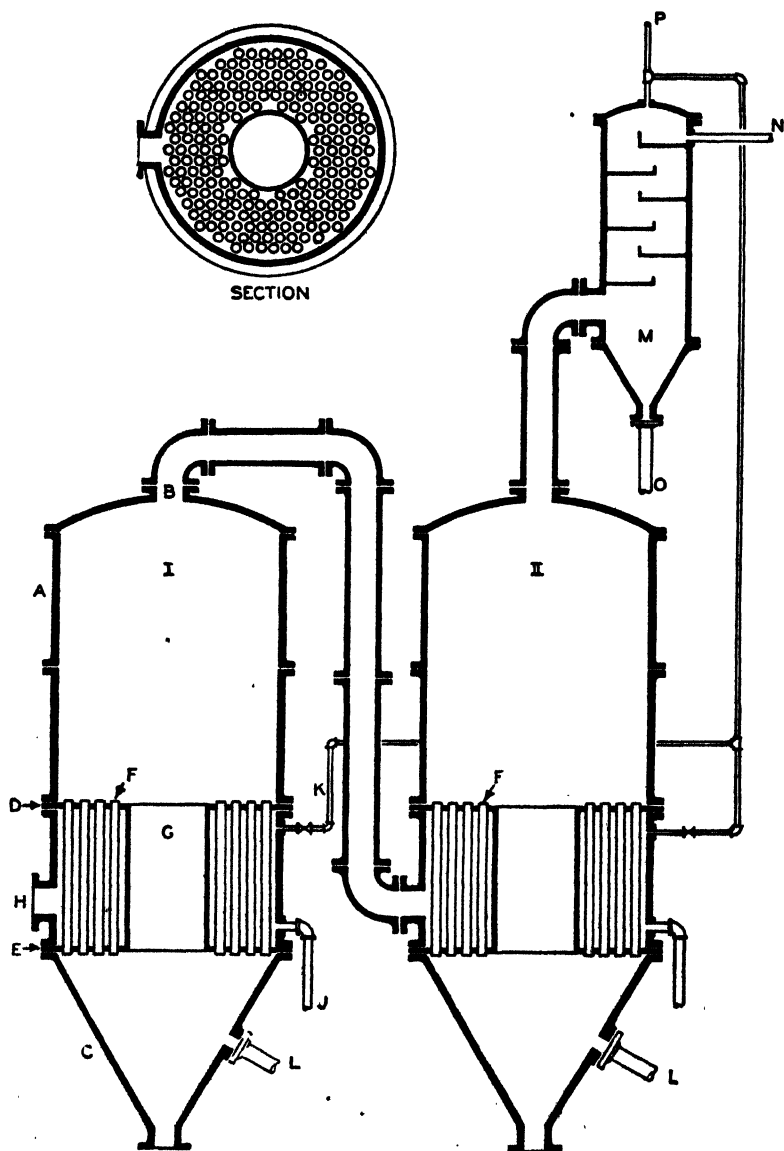

FIG. 6.—Double-effect salt evaporator.

leaves by pipe *O* and the condenser is usually set high enough (approximately 34 feet above the hot well) so that this water is discharged by gravity. A vacuum pump is connected to pipe *P* and serves to remove any air that may have reached the condenser through pipe *K*, through the vapor pipe from effect II, and that liberated from the condenser water.

As the steam which surrounds the tubes is hotter than the brine in them, it will condense and transmit its heat to the brine.



FIG. 7.—Vacuum-pan salt. ($\times 20$.)

The condensation in effect II of vapor from pipe *B* produces a partial vacuum in effect I which maintains the boiling point of the brine below the temperature of the steam. As the brine boils inside the tubes *F*, the lifting effect of the steam bubbles causes the brine to circulate upward through the tubes and it is returned through dwtake *G*. A propeller is generally placed in the dwtake of salt evaporators to assist this circulation. The vacuum produced in the condenser maintains the brine in the

second effect at a temperature lower than that of the vapors coming from the first effect and, therefore, these vapors will cause boiling in the second effect.

The removal of the water causes the separation of salt, forming small nuclei. These nuclei are suspended freely in the circulating brine, hence they grow uniformly on all sides and develop as perfect cubes. When these cubes become so large that they can no longer be held in suspension, they settle into the cone *C* and are removed in various ways. The result is that salt produced in this manner is in the form of cubical crystals of a very uniform size. Figure 7 is a photomicrograph of vacuum-pan salt.

Methods of Feeding and Salt Removal.—Many salt evaporators are fed by introducing the brine into each body by a connection such as *L* (Fig. 6). This is the simplest method of feeding a multiple effect evaporator and is known as *parallel* feed. If there are appreciable amounts of impurities (such as calcium chloride or magnesium chloride) in the brine, it may be desirable to concentrate these impurities in one effect from which they may be discarded as bittern, by feeding all the brine to one effect and from this effect to the others in series. This method is always used in evaporators that concentrate dilute solutions. If the initial feed goes to the hottest effect and then passes in series to the coldest effect, the method is known as *forward* feeding. If the solution is fed in the opposite direction, it is known as *backward* feeding.

A method of salt removal, which has been common but which is becoming obsolete, is to extend the cone into a fairly long pipe that discharges into the boot of a bucket elevator. The elevator is enclosed to a level above the normal brine level so that when the evaporator is shut down the brine will not overflow through the elevator. The boot itself must be far enough below the normal brine so that air cannot be drawn into the evaporator through the elevator casing. When this method of removal is used, the salt is accompanied by about an equal weight of brine. The wet mixture of brine and salt is either centrifuged, or discharged into bins where it drains for several days before being withdrawn.

The method which at present is considered the best practice is to attach a centrifugal pump directly to the cone of the evaporator. The mixture of salt and brine removed by this pump is

sent to a settling tank, from the top of which the excess brine overflows to be returned to the evaporators, and from the bottom of which the salt is withdrawn into centrifuges or filters.

Figure 6 shows a double effect merely for the purpose of illustration. Salt evaporators may be single effect, in which the vapors from outlet *B* go directly to the condenser, or there may be more than two effects in series. Four effects are the present limit in this direction. Salt evaporators vary from small single effects 6 feet in diameter up to quadruple effects with each body 20 feet or more in diameter.

Capacity of Evaporators.—The amount of salt produced by an evaporator is directly proportional to the amount of water evaporated and this is in turn proportional to the amount of heat passing through the heating surface. If the brine is not fed to the evaporator at the boiling point, the amount of heat necessary to evaporate a pound of water is increased by the amount of heat necessary to raise the brine to the boiling point; but this increase will always be relatively small. The amount of heat passing the heating surface is the product of two factors: first, the difference in temperature between the steam on one side of the tube and the boiling brine on the other; and second, the coefficient of heat transfer.

A single-effect evaporator may be operated with heating steam supplied at about 5 pounds gage and with the brine boiling under a vacuum of 26 inches. The temperature of the steam is 227°F. and under a vacuum of 26 inches, water will boil at 125°F. If water were boiling in this evaporator, therefore, the available working temperature drop would be 102°F. The boiling point of saturated salt brine under a 26-inch vacuum is not 125°F. but 139°F.⁽⁹⁾ and, therefore, this single-effect evaporator will have an available working temperature drop of only 88°F. instead of 102°F. In other words, the effect of an appreciable elevation in boiling point is to decrease the capacity of an evaporator for boiling a solution as compared to its capacity on water.

In the double effect of Fig. 6, if steam were supplied to the first effect at 5 pounds gage and a vacuum of 26 inches were maintained on the second effect, there would be an available temperature drop across the two effects of 102°F. if water were being boiled. The temperature of the vapor leaving the first effect and heating the second would be some intermediate temperature

determined by the equilibrium which the evaporator automatically maintains between the generation of steam in the first effect and its condensation in the second. If this evaporator is boiling brine instead of water, there will be a loss of 14° temperature drop in the second effect according to the reasoning in the preceding paragraph. The saturation temperature of the vapor leaving the first effect will be about 15°F. lower than the boiling point of the brine in the first effect. The superheat in the vapor is negligible in comparison to the latent heat; and since the latter becomes available only by condensation at the saturation temperature, it follows that the first effect also loses from its temperature drop the elevation in boiling point of the brine. Under these conditions, then, while the apparent temperature drop of this double effect is 102°F. , the available temperature drop, distributed between the two effects, is only 73°F.

If this reasoning be extended to triple and quadruple-effect evaporators, it will be seen that if the number of effects is increased, the elevation in boiling point is lost in each effect; and the sum of these losses may become so large that the working temperature drop remaining will be too small for practical operation. It is possible to increase the total temperature range only slightly, for an increase in vacuum is expensive, and lowering the boiling point in the last effect decreases the heat transfer coefficients. Salt evaporators are almost never designed to carry pressures higher than 25 pounds gage. The bodies should be made of cast iron to resist corrosion, and constructions that will stand even moderately high pressures are too expensive to be economically justified.

The coefficient of heat transfer in any evaporator is considerably affected by the magnitude of the temperature drop, the rate of circulation, the temperature of the liquid, and by even minor changes in the proportions of the evaporators. If it is assumed, however, that a particular evaporator operating under definite conditions has a definite heat transfer coefficient, this coefficient does not remain constant in operation due to two factors—scaling and salting.

After evaporation has proceeded for a short time, the brine will begin to precipitate calcium sulfate. The solubility of calcium sulfate is shown in Fig. 8. While this figure represents its solubility in pure water, its solubility in saturated sodium

chloride solutions, though not known, is presumably similar. Since all salt evaporators operate at temperatures above that at which calcium sulfate has its maximum solubility, it follows that in an evaporator the solubility of calcium sulfate will decrease with increasing temperatures. The thin film of brine immediately adjacent to the wall of the tube is hotter than the rest of the brine and therefore calcium sulfate will be deposited

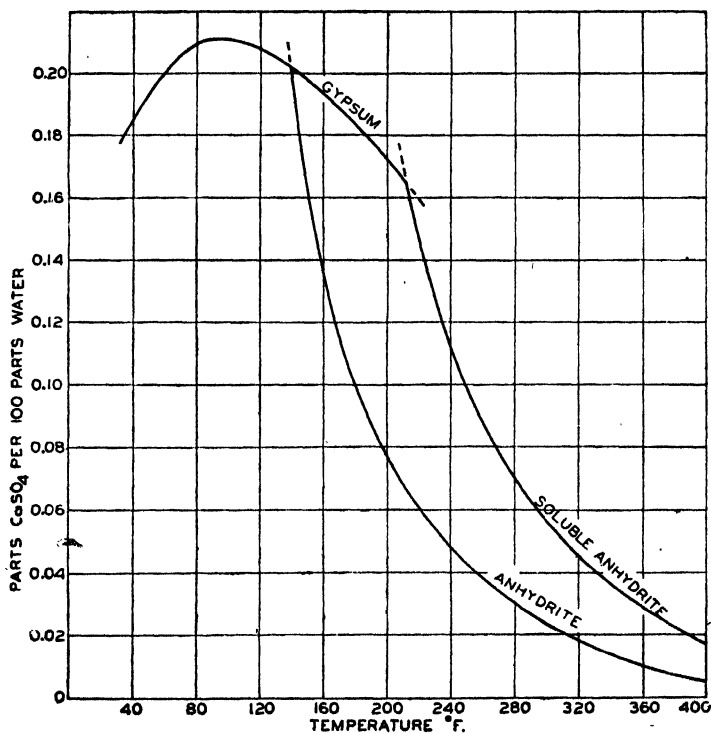

Fig. 8.—Solubility of calcium sulfate.

from this layer rather than in the body of the solution. Consequently anhydrous calcium sulfate separates mainly as a hard scale on the tubes, decreasing the rate of heat transfer and cutting down the capacity of the evaporator. This scale formation begins almost as soon as the evaporator is put into operation, and with most brines continues at such a rate that at least once a week the evaporator must be shut down and scale drilled out of the tubes. According to the degree of purification of the brine

and the control of its pH, the rate of scaling may be greatly decreased or eliminated entirely.

The phenomenon of salting consists of the growing of salt crystals on the tubes to form a compact mass. This cannot be explained by the previous line of reasoning because the solubility of salt increases with temperature. Salting can be minimized, but not eliminated, by active circulation of the brine. It can also be decreased by carrying a high brine level, although the reason for this is not known. This growth is much faster than the growth of calcium sulfate scale, so that salt evaporators usually must be boiled out with fresh water at least once in 24 hours, and sometimes once in 12 hours. A clean salt evaporator should have a coefficient of 300 to 350 B.t.u. per square foot per degree Fahrenheit per hour. This may fall to as low as 50 to 75, due to scaling and salting, before the evaporator is washed out. During a large part of the operation, however, the coefficient will be fairly constant at about 200 to 250. These figures will vary widely in different installations.

THE ALBERGER PROCESS

The general principle of the Alberger process is that brine is heated under pressure, and then by release of this pressure evaporation takes place adiabatically. The sensible heat liberated by the cooling of brine to its boiling point under atmospheric pressure furnishes the latent heat of evaporation.

Alberger Flow Sheet.—Cold brine from the wells, saturated at about 60°F., is pumped by the feed pump (Fig. 9) to heater I where it is warmed. It is then mixed with the overflow from the pans and passes to the circulating pump. Pressure on the discharge of this pump is kept at about 30 to 50 pounds gage. The circulating pump forces the brine through the heaters II, III, IV, and V, in series. The supply of steam to heater V is at such a pressure that the brine leaves it at a temperature of 280 to 300°F. The pressure produced by the circulating pump is so adjusted that the brine does not boil at the temperature at which it leaves heater V.

At the temperature reached in this heater the solubility of calcium sulfate is very low, (see Fig. 8). At this point in the system, therefore, there should be about 2 parts of calcium sulfate per 10,000 parts of brine. Actually, due to the very

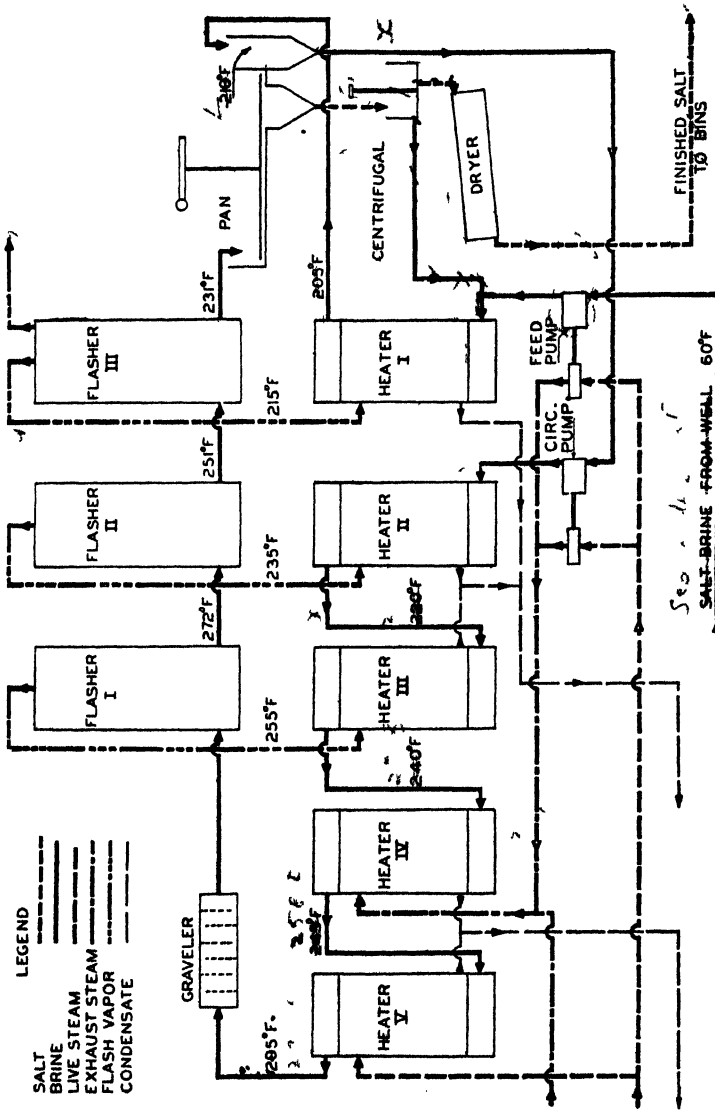

Fig. 9.—Flow sheet of Alberger process

low velocity of crystallization of calcium sulfate and its consequent tendency to form supersaturated solutions, only a part of the calcium sulfate which should be deposited comes out at this point. Obviously, from the considerations given on page 25, the calcium sulfate which does separate in the heater will come out as hard scale on the tubes. (In order to complete the removal of calcium sulfate it is necessary to hold the brine for an appreciable time at a high temperature or to increase the rate of crystallization. The latter can be accomplished most readily by bringing the solution into contact with extended surfaces of the solid phase. This is done by passing the brine, after it leaves heater V, into the graveller. This consists of a horizontal steel cylinder about 10 feet in diameter and 15 feet long, mounted on trunnions so that it can be rotated, and with partitions in it as indicated to make the brine flow in a long path. The graveller is nearly filled with cobblestones and these are always coated with more or less calcium sulfate. This combination of a relatively long time of contact and a relatively large surface of calcium sulfate brings the anhydrite content down nearly to equilibrium value. Two gravellers in parallel are supplied for each Alberger system. While one of these is removing calcium sulfate from hot brine, the other is being rotated so that the grinding action of the pebbles will remove the calcium sulfate from their surfaces. The pulverized anhydrite is removed from this graveller by a stream of water. It is this method of removal of calcium sulfate from the brine which formed the original purpose of the Alberger system and remains one of its important features. Cooling in the rest of the brine cycle so increases the solubility of calcium sulfate that, in spite of evaporation, the solution becomes unsaturated with respect to calcium sulfate, so that none is separated with the salt.

After leaving the graveller the brine, still hot and under pressure, passes through the flashers I, II, and III. These consist of vertical steel cylinders with brine inlets and outlets near the bottom and a vapor outlet at the top. They are so arranged at different levels that a part of the pressure is released in each one, thereby giving off vapor from each at a different temperature. In flasher III the pressure drops to atmospheric and the brine flows out into a large shallow pan. During its passage through the flashers enough water has been removed in the form of

flash vapor so that seed crystals appear in flasher III and are suspended in the brine discharged to the pan. In the actual operation of the process there are two of these pans, each about 40 feet in diameter, provided with very slow moving circular rakes. The brine travels through these pans in series and finally overflows, to be mixed with the feed brine, as described. During this passage the brine is so hot that surface evaporation takes place as in the ordinary grainer, but because of the high temperature the loppers formed are small and of a very fine structure. While the brine is cooling it throws out more salt which serves to knit together the seed crystals, formed in flasher III, into flat flakes. All of the salt is raked into a well at the far side of the second pan. From this well it is drawn as a heavy sludge of salt and brine to a centrifuge, and the salt is still further dried in a rotary steam-heated drier. From this drier the salt is taken to departments where it is screened and packed.

The most important feature of the Alberger process at present is its steam flow-sheet. The flashers I, II, and III yield steam at three different pressures. These vapors go to operate the heaters III, II, and I, respectively. Heater IV is operated on exhaust steam from pumps and other steam-using devices, and heater V is operated with steam taken directly from the boilers. It is not possible to absorb all of the vapor from flasher III in heater I and therefore some vapor is blown to the air at this point.

The connection between flashing in several steps and steam economy may be followed most easily by comparing this system with a one-flash system. Suppose that the system contained only the flasher III and that in this flasher pressure on the brine was released from that at which it leaves the graveler to atmospheric. All the vapor leaving flasher III would then have a saturation temperature of 212°F. and it would be impossible to heat the brine with flash vapor any hotter than this, even in an ideal case. In any actual system, of course, the temperature of the brine leaving the heater would have to be several degrees below 212°F. All the rest of the heating from this temperature to the final temperature at which the brine leaves heater V would have to be accomplished with exhaust or live steam. Exhaust steam is available only at comparatively low pressures and most of the work would be done with live steam. Neglecting radiation from the system, every 1,000 B.t.u. put into the brine by live

and exhaust steam would release 1,000 B.t.u. in the flasher. Therefore (under ideal conditions the system could only evaporate approximately 1 pound of water per pound of steam supplied. If now, instead of one flasher, three are used, vapor is available for heating at temperatures above 212°F.; the brine going to the live steam heater V is hotter than before, and, therefore, less live steam is used in heater V. On the other hand, since



FIG. 10.—Alberger salt. ($\times 20$.)

the maximum temperature in the system remains the same as in the previous example, 1,000 pounds of brine in dropping through the same temperature range will yield just as many B.t.u. by flash as before and therefore produce as much evaporation as before. Much less steam has been used and, therefore, the evaporation will be more than 1 pound of water per pound of steam. The system indicated in Fig. 9 has approximately the steam economy of a double-effect evaporator. Theoretically,

more flashers should give a higher steam economy, but in practice it is found that the increasing difficulties in operation and control make it advisable to limit the system to three flashers.

Structure of Alberger Salt.—From the above discussion, it is apparent that there will be two distinct types of grain in the finished product from this system. One is a typical hopper formed by surface evaporation in the pans, and the other is a flat flake or long needle caused by the knitting together of the seed crystals formed in the last flasher. These seed crystals are cubes measuring approximately 0.008 inch on a side. Figure 10 shows both types of grain and it will be noted that in the flakes the unit cubes can still be distinguished. The result of this structure is that Alberger salt has a larger surface per unit weight than any other salt of the same screen size. This gives it the property of dissolving very rapidly.

DRYING AND SCREENING

Formerly nearly all salt that was shipped in bulk and much that was shipped in barrels or 100-pound sacks was dried only by standing on the warehouse floor. This included most grainer salt and much vacuum-pan salt. At present, practically all salt is dried and screened. The usual salt drier consists of a cylindrical shell, 7 or 8 feet in diameter and about 30 feet long, rotated on rollers by means of a gear drive. The metal shell may be lined with maple staves, although at present the preferred lining is monel metal. On the inner surface of the lining are fastened iron or monel angles, parallel to the long axis of the drier, which serve, as the shell rotates, to lift the salt and shower it down through the center of the drier. The drier is set at a slight pitch to feed the salt from one end to the other. At the discharge end, the dried salt is removed by a screw conveyor and taken to the screening and packing departments. A fan blows air, which has been heated by steam coils, through the drier. In addition to this source of heat, there may be a steam drum or steam coils located in the center of the drier itself so that the salt will fall on these heated surfaces as the shell rotates. These also serve to reheat the air, which is being cooled by the adiabatic evaporation of water from the salt.

Salt was formerly sized with rotating, cylindrical screens; but now flat, inclined shaking screens are almost universally used.

In designing these, there must be some provision to keep the screen vibrating, in order to prevent the wedging of particles into the meshes of the screen, known as *blinding*. This may be accomplished by attaching an iron strip to the screen and causing it to vibrate by means of an alternating-current magnet. Another method involves attaching vertical metal pins to the screen at a number of points and allowing these pins to project through the casing. Outside the casing are rotating shafts carrying swinging arms which strike the pins and vibrate the screen. In either method the screen must be mounted on a framework in such a manner that it can be stretched tightly. Most of these inclined screens are provided with more than one layer of wire cloth, properly spaced and, therefore, make more than one separation at a time.

Vacuum-pan salt is usually so uniform that it is merely necessary to take out the fine dust and the large lumps, leaving the remainder in a single fraction. Grainer salt and Alberger salt are screened into a larger number of fractions, sometimes as many as six sizes being recognized.

RELATIVE STATUS OF PROCESSES

The old direct-fired processes became obsolete for several reasons. In the first place, the thermal economy was low and the distribution of heat poor, because of lack of care in firing. In the second place, because of the separation of scale on a surface that was heated by direct fire, the temperature of the metal became so high that the bottoms of the pans warped badly, necessitating frequent repairs. In the third place, this warping made it impossible to use mechanical rakes for removing the salt, and the labor cost became prohibitive. Finally, the quality of the salt was far from uniform and a close control of the process was difficult.

The grainer system was a step in advance of this, because, with automatic rakes, the labor cost was lower; and the steam used was generated in a boiler where firing could be done more economically. It should be noted however, that the grainer process originated in connection with the lumber industry and was at first a method for utilizing heat generated by the burning of waste wood. During this period the grainer process became firmly established and a demand was created for the type of

grain which it produces. Such grainers as are still used are operated to satisfy this demand. Their disadvantage is that they use steam in single effect only, and they lose in the air much heat that escapes at relatively high temperatures. The temperature of the brine is uniform from end to end of the grainer and this produces more uniform grain size than can be obtained from a direct-fired pan.

As the prejudices of the trade are overcome, production is being shifted to the vacuum-pan method; because this produces an extremely uniform salt with the minimum expenditure for labor and steam. Two men can operate an evaporator that produces 200 tons of salt per day. It would take 20 grainers and about 10 men to produce this same amount of salt by the grainer process, with the added difference that the grainer produces about 1 pound of salt for 4 pounds of steam, whereas a quadruple-effect evaporator will produce 1 pound of salt from a little over 1 pound of steam. This was of no consequence when heat was available from waste wood, but it is a decidedly important matter when the steam must be raised by burning coal. Increasing fuel prices are accelerating this change. The 200-ton quadruple-effect evaporator will occupy a floor space not much greater than that occupied by two grainers. The first cost of a quadruple-effect evaporator is between 25 and 50 per cent more than the first cost of the same capacity in grainers. This is, however, overbalanced by the saving in steam.

The Alberger system is operated by one company only. It is operated because it produces a special type of grain for which this company has created a nation-wide demand. Its steam economy is about that of a double effect. Its operation involves many difficulties, and it is improbable that any other company will ever adopt this system. It has been discussed in this chapter because it represents a novel and decidedly interesting way of performing evaporation.

References

- (1) CLARKE, F. W., "Data of Geochemistry," *U.S. Geol. Survey, Bull.* 770, p. 127 (1924).
- (2) VAN'T HOFF, J. H., "Physical Chemistry in the Service of the Sciences," Univ. of Chicago Press, Lectures VIII and IX (1903).
- (3) PHALEN, W. C., "Salt Resources of the United States," *U.S. Geol. Survey, Bull.* 669.

- (4) STEINMAYER, R. A., "Salt-domes of the United States," *Trans. Am. Inst. Chem. Eng.*, **25**: 239-249 (1930); *Chem. Met. Eng.*, **39**: 388-389 (1932).
- (5) HARRIS, G. D., "Economic Geology," **IV**: 12-35 (1909).
- (6) COOK, C. W., "Brine and Salt Deposits of Michigan," *Mich. Geol. Biol. Survey, Publication* 15 p. 39 (1914).
- (7) PHALEN, W. C., "Technology of Salt Making in the United States," *Bur. Mines, Bull.* 146, p. 41.
- (8) BADGER, W. L., Salt Manufacture in Michigan, *Chem. Met. Eng.*, **24**: 201-207 (1921).
- (9) BADGER and BAKER, *Trans. Am. Inst. Chem. Eng.*, **13** (I): 151-168 (1920); *Chem. Met. Eng.*, **23**: 569-574 (1920).

Problems

1. Sea water of 3.7 per cent total solids, of the composition given in Table II, was evaporated in solar ponds under the conditions given in Table III. The bittern discarded from the final ponds contained 3.4 grams per liter of $MgBr_2$, 339 grams per liter of total solids, and 98 grams per liter of $NaCl$. It had a specific gravity of 1.25. How many acres of pond surface would be needed to produce 15,000 tons of salt for the season? How many pounds of water are evaporated per pound of salt made?

2. The top of a cavity of a salt well such as shown in Fig. 2, is 1,280 feet below the well head. The cavity is filled with saturated brine of a specific gravity of 1.21. Water is pumped down the annular space and displaces brine, which is forced up through the central pipe. If the fresh water has a specific gravity of 1.00, what pressure is required to lift the brine, in addition to the pressure required to overcome friction?

3. Brine *B* in Table V has a specific gravity of 1.20. In a particular plant 4.5 tons of this brine are used to produce 1 ton of finished salt. How much would it cost, per ton of salt, to completely purify this brine, if soda ash 98 per cent pure costs \$1.75 per 100 pounds, and hydrated lime 92 per cent pure costs \$1.10 per 100 pounds? Assume that the Ca is precipitated as $CaCO_3$, and the Mg as $Mg(OH)_2$.

4. Check the values for the coefficient of heat transfer in Table VI. Assume that the average specific heat of the brine is 0.79.

5. The following data were obtained from a 24-hour test on a grainer:

Heating surface of coils, square feet	= 1,700
Average temperature of entering brine	= 120°F.
Average temperature in the grainer	= 180°F.
Average steam temperature in coils	= 225°F.
Average temperature of condensate from coils	= 220°F.
Quality of entering steam	= 100 per cent
Weight of condensate, 24 hours	= 80,000 pounds
Pounds of wet salt made, 24 hours	= 30,000 pounds
Per cent H_2O in wet salt	= 21.0 per cent
Per cent $NaCl$ in entering brine	= 26.0 per cent

Calculate:

- a. How much brine is fed per day?
- b. How much water is fed?
- c. How much water is evaporated?
- d. How much salt is dissolved in the water taken out with the wet salt?
- e. How much solid salt, *i.e.*, "salt made in the grainer" is taken out as product?
- f. How much heat is required to heat the brine to the temperature of the grainer?
- g. How much heat is required to vaporize the water evaporated?
- h. How much heat is supplied to the grainer?
- i. What is the thermal efficiency of the grainer?
- j. What is the coefficient of heat transfer?

6. A single-effect salt evaporator is fed with saturated brine at 60°F. It is supplied with steam at 10 pounds gage, and the vacuum is 26 inches referred to a 30-inch barometer (boiling point of brine, 138°F.). Salt is withdrawn from the evaporator as a slurry containing 36.45 per cent H₂O and 63.55 per cent NaCl at 138°F. This slurry is cooled to 80°F. and is then centrifuged down to 5 per cent H₂O. The excess brine is discarded. The centrifuged salt is dried to 0.2 per cent H₂O in a rotary drier (without mechanical loss of the adhering brine). The weight of the "dried salt" (0.2 per cent H₂O) is 4 tons per hour. The evaporator has vertical tubes, 2½ inches in diameter by 48 inches long. If the coefficient of heat transfer is 165 B.t.u. per square foot per hour per degree Fahrenheit difference between steam and boiling brine, how many tubes must the evaporator have? Assume that the condensate leaves the evaporator at 150°F.

7. What would be the capacity of this evaporator, if it were boiling water instead of brine, all other conditions remaining the same?

8. A double-effect evaporator is to be operated with steam on the first effect, vacuum on the second effect, and brine feed all the same as in Problem 6. Salt is to be withdrawn from each effect as a slurry containing 36.45 per cent H₂O and 63.55 per cent NaCl at the boiling temperature in each effect. Each of these slurries is to be cooled to 80°F. and then centrifuged down to 5 per cent H₂O. The excess brine is discarded. The centrifuged salt is dried to 0.2 per cent water in a rotary drier (without mechanical loss of the adherent brine). The total weight of the "dried salt" (0.2 per cent H₂O) from the double-effect evaporator is 4 tons per hour. The heating surfaces in the two effects are equal, and each will be somewhat larger than in the single effect of Problem 6, but the tubes are to be of the same length and diameter. The heat transfer coefficients are 200 B.t.u. per square foot per degree Fahrenheit per hour in the first effect, and 135 in the second effect. Condensed water leaves the first effect at 215°F. and leaves the second effect at 150°F. Assume that the brine boils at 201°F. in the first effect, and at this pressure water boils at 186°F. Assume that the first cost of both the single effect of Problem 6 and of this double effect is \$6 per square foot of heating surface, and that the fixed charges (interest, depreciation, etc.) are 20 per cent per year. Assume that steam costs 30 cents per 1,000 pounds; and that the evaporators work 22 hours per day, 300 days

per year. How much less would it cost per ton to make salt with a double effect than with a single effect?

9. The following data, in addition to those given in the figure, are available on the Alberger process flow sheet of Fig. 9:

Salt made per day: 800 barrels (280 pounds per barrel).

Brine: Saturated at 60°F.

Radiation, B.t.u. per day:

In heater I: 300,000. In flasher I: 450,000.

In heater II: 500,000. In flasher II: 425,000.

In heater III: 600,000. In flasher III: 500,000.

In heater IV: 650,000.

In heater V: 700,000. In pan: 5,000,000.

Boiling point elevation of brine in pan: 15°F.

Specific heat of all brines may be taken as 0.79.

Temperature of steam to heater V: 345°F.

Temperature of steam to heater IV: 250°F.

Temperature of condensate from heater V: 260°F.

Temperature of condensate from heater IV: 250°F.

Temperature of brine leaving graveller: 292°F.

Temperature of brine entering heater II: 210°F. (approx.).

Take temperature of brine from heater I as 210°F. instead of 205°F. as shown in Fig. 9.

Excess vapor from flasher III not needed in heater II is vented to the atmosphere.

Neglect water carried out on centrifuged salt.

Calculate:

- The brine fed to the system, in pounds per day.
- The total evaporation, in pounds per day.
- The flow of brine through the circulating pump, in gallons per hour.
- The evaporation in each of the flashers and in the pan.
- The steam supplied to heaters V and IV, in pounds per hour.
- Evaporation, pounds water per pound steam supplied.

CHAPTER III

SULFURIC ACID

Sulfuric acid is the most important product of the inorganic chemical industries. It enters into so many different processes in large amounts that the sulfuric acid market may be considered a better barometer of business conditions than even the iron and steel market. This is not only because sulfuric acid has fully as many applications as iron and steel, but also because, since it is rarely stored, its production and consumption respond more quickly to changes in business activities. Sulfuric acid not only represents the condition of manufacturing industries, but because of its use in fertilizer manufacture it is equally significant as a barometer of agricultural conditions. It has even been said that the industrial development of any country can be measured by its consumption of sulfuric acid.

The technology of sulfuric acid is remarkable in that the chamber process has been operated for seventy years with practically no significant changes in equipment and method beyond those that were made at the very beginning. In the last 20 years, with a better understanding of such unit operations as combustion, fluid flow, heat flow, gas absorption, and the mechanism of heterogeneous reactions, a number of attempts have been made to redesign the old chamber process in the light of this new knowledge. Only one of these modifications, the Mills-Packard, has had any appreciable acceptance beyond the initial plants built by the respective inventors. Probably one reason for the failure of the industry to adopt the newer engineering ideas in chamber plants is that it is generally recognized that the future of this process, even with these improvements, is decidedly questionable. Existing chamber plants will probably continue to operate as long as it is economical to run them, and will then be superseded by contact acid plants.

Production and Distribution.—The production of sulfuric acid in the United States in 1940 was equivalent to 9,150,000 short

tons of 50°Bé. acid. This was distributed amongst the various uses as follows:

TABLE VII.—USES OF SULFURIC ACID

	Per Cent
Fertilizers.....	24.7
Petroleum refining.....	13.9
Iron and steel.....	13.2
Chemicals.....	11.9
Coal products.....	9.8
Other metallurgical.....	7.0
Paints and pigments.....	6.2
Rayon and cellulose film.....	5.1
Explosives.....	1.9
Textiles.....	1.4
Miscellaneous.....	4.9

The enormous consumption of acid in the fertilizer industry usually results in acid plants and fertilizer plants being in the same locality. In many cases, the acid plant is operated by the fertilizer factory. The fertilizer plant ordinarily uses acid of 50°Bé. and is, therefore, supplied directly with this dilute acid. Other industries either need concentrated acid, or need small enough tonnages so that they may purchase concentrated acid and dilute it. Hence, they do not need to be located at producing centers. The manufacture of explosives, and some branches of the chemical industry, use acids of extremely high strength and may operate their own plants to produce these.

Sulfuric acid is ordinarily sold as 50°Bé. or chamber acid (62.18 per cent H_2SO_4), 60°Bé. acid (77.67 per cent H_2SO_4), and 66°Bé. acid, or oil of vitriol (93.19 per cent H_2SO_4). Acids stronger than 66°Bé. are usually spoken of by their per cent acid concentration, and 100 per cent sulfuric acid is commonly called monohydrate.

Sulfur trioxide dissolves in monohydrate to give fuming acids or oleums. The strength of these may be expressed in various ways. An acid containing 20 pounds of free SO_3 dissolved in 80 pounds of H_2SO_4 might be spoken of as 20 per cent oleum, or as acid containing 85.3 per cent total SO_3 . If to 100 pounds of this mixture sufficient water (4.5 pounds) be added to combine with the free SO_3 , there will result 104.5 pounds of 100 per cent H_2SO_4 . From this point of view such acid would be called 104.5 per cent acid.

RAW MATERIALS

The earliest commercial raw material for the manufacture of sulfuric acid was sulfur from Sicily. Later many plants turned to iron pyrites (FeS_2) as their raw material. This trend increased until at the beginning of the present century the larger proportion of sulfuric acid made in this country was made from pyrites. When cheap sulfur of high purity from American sources became available, more and more plants turned to sulfur, until in 1920 about 80 per cent of the acid made in this country was made from sulfur. The margin of cost between the two raw materials is small, and for some years the balance between these costs has resulted in making a gradually increasing percentage of the total from sulfur.

Sulfur.—Before 1900, the world's production of sulfur came entirely from deposits in volcanic regions, the most important of which was in Sicily. Sulfur was mined in the form of a porous rock that contained up to 40 per cent free sulfur. The methods employed were crude and usually consisted in piling the ore in heaps, starting a fire at the bottom, and allowing the heat from the combustion of part of the sulfur to melt the rest, which was collected in molds below the heap. The recovery was incomplete and in recent years more economical apparatus has been used. Even so, the yield is small and the cost high. A small amount of sulfur was imported into the United States as late as 1916 but since that time there have been practically no imports.

The producing areas in the United States consist of a few scattered deposits, each covering a relatively small area, in the Louisiana-Texas coastal plains. Each of these deposits lies above an anhydrite layer cap rock of a salt dome. Although these deposits were known in 1865, it was not until the development of the Frasch process in 1891 that production was possible. The Frasch process was so successful that in a relatively short time it was producing almost all the sulfur used in this country.

In these deposits, sulfur occurs distributed through a limestone rock, which is covered by thick layers of alluvial deposits and quicksand that effectively prevent its recovery by ordinary mining methods. The Frasch process^(1,2,3) consists in pumping highly heated water into the rock to melt the sulfur, and then

raising the melted sulfur to the surface with an air-jet lift. A 10- or 12-inch hole is drilled to the sulfur-bearing layer and cased to

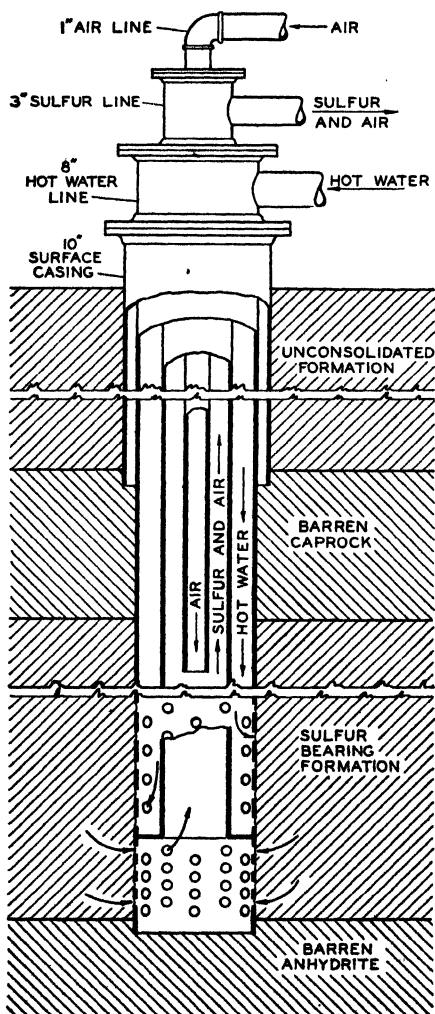

Fig. 11.—Sulfur well.

the surface of the rock (Fig. 11). Inside this casing are three other concentric pipes, about 8, 3, and 1 inch, in diameter respectively.

The 8-inch pipe is perforated where it passes through the sulfur-bearing layer. Water superheated to 300 to 320°F. is pumped

down between the 3-inch and the 8-inch pipe and flows into the sulfur-bearing stratum. The molten sulfur collects in a pocket at the bottom of the 8-inch pipe. Compressed air sent down the 1-inch pipe lifts the sulfur to the surface in the 3-inch pipe. The water is removed through *bleed wells* located around the outer edge of the area to be worked. The sulfur-air mixture is discharged to shallow pits from which the molten sulfur is pumped to large plank bins, where it solidifies.

These blocks of sulfur, which may contain several thousand tons, are later broken up with explosives and shipped. The sulfur so produced is 99.5 to 99.8 per cent pure and is free from arsenic and selenium but does contain small amounts of asphaltic material and incombustible residue.

The effect of the Frasch process on the situation in the United States is strikingly pictured in Table VIII.

TABLE VIII.—PRODUCTION OF SULFUR IN METRIC TONS

Year	United States imports	United States production	World production
1895	126,760	1,676	398,916
1900	167,328	4,630	581,282
1901	175,310	6,977	604,930
1902	176,951	7,565	552,996
1903	190,931	35,660	631,035
1904	130,421	196,588	767,249
1905	84,579	218,440	830,609
1910	30,544	259,699	787,732
1915	24,647	299,133	860,000
1920	44	1,542,059	1,941,052
1925	102	1,431,912	2,213,330
1930	29	2,558,981	3,091,709
1935	1,763	1,632,590	2,254,000
1939	14,000	2,091,000	2,900,000

In recent years, a beginning has been made in the production of sulfur as a by-product of various industries. Sulfur is now being produced in small amounts, but on an industrial scale, from sulfur compounds removed in the purification of nitrogen and hydrogen in the manufacture of synthetic ammonia; from various by-products obtained in the removal of sulfur compounds from coal gas; and by the reduction of sulfur dioxide with coke. This last proc-

ess is at present in operation at a copper-lead smelter at Trail, B.C.⁽⁶⁾ All of these methods combined do not produce an important amount of sulfur at present, but the production of sulfur from smelter gases seems to have appreciable possibilities, especially for smelters so located that they find it more economical to ship sulfur than to convert the sulfur dioxide into sulfuric acid and ship the acid to consuming points.

Pyrites.—Iron pyrites is usually represented by the formula FeS_2 and if pure should contain 53.4 per cent sulfur; but the mineral actually mined is variable in composition. Most manufacturers demand pyrites containing over 42 per cent sulfur. During the World War, material as low as 30 per cent sulfur was accepted. In 1937 the domestic production was about 50 per cent of the total consumption.

Other Raw Materials.—In the metallurgy of most of the non-ferrous metals there is a step that involves roasting a sulfide ore. This operation produces sulfur dioxide that might be used as a raw material for sulfuric acid manufacture. At present, however, this material is important only at zinc smelters, where considerable amounts of sulfuric acid are made from the waste gas from roasting zinc sulfide. In a few cases, sulfuric acid is made from the waste gas of copper smelters, but such plants are usually too far from consuming centers or else they produce gas so variable in composition as to be unsuitable for sulfuric acid manufacture.

In 1937 the relative production of acid in the United States from different sources was as follows:

TABLE IX.—SULFURIC ACID PRODUCTION ACCORDING TO RAW MATERIALS

	Per Cent
From sulfur.....	64.4
From pyrites:	
Imported.....	12.5
Domestic.....	11.9
By-product sources.....	11.2

CHAMBER PROCESS

Sulfuric acid may be made by several processes, of which the most important are the chamber process and the contact process. A general outline of the chamber process is given in Fig. 12, which is purely diagrammatic and indicates only the most important elements in the process. Sulfur is burned with sufficient excess air so that the concentration of oxygen is slightly greater than

that of sulfur dioxide. Nitric oxide, obtained by the oxidation of ammonia, is introduced into the gas stream. The gas mixture then passes to the base of the Glover tower, down which acid is flowing. The gas rises through this tower, concentrating the acid, thereby becoming cooled and picking up considerable water vapor. From the top of the Glover tower the gases are conducted to the lead chambers, of which there may be from

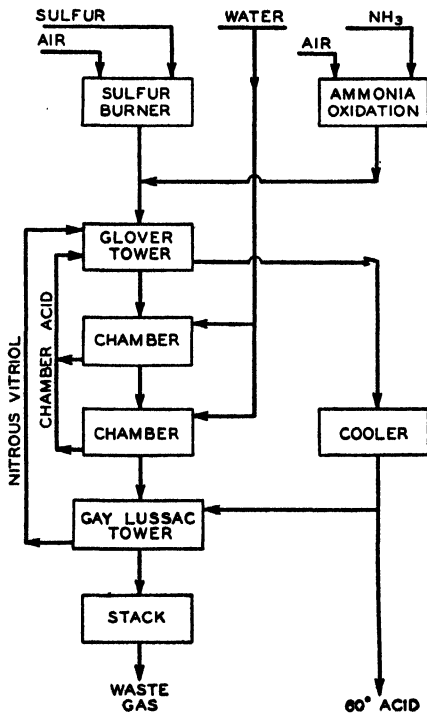

Fig. 12.—Flow sheet of chamber process.

four to eight, although only two are shown in the diagram. Intermediate towers may or may not be placed between the chambers. Water is introduced into the top of the chambers, either in the form of spray or steam. In the chambers sulfur dioxide, oxygen, water, and the oxides of nitrogen react to form sulfuric acid, which collects in the bottom of the chambers and is drawn off as chamber acid of about 50°Bé. At the end of its passage through the chambers, the gas has lost most of its

sulfur dioxide, but still contains oxides of nitrogen. These are recovered in the Gay-Lussac tower by absorption in a stream of cold 60° acid introduced at the top. The residual gas, consisting largely of nitrogen and oxygen, is discharged into the air from a stack.

The chamber acid is fed to the top of the Glover tower, and in its passage down this tower is concentrated to about 60°Bé. From the base of the Glover tower it passes through a series of coolers. Part of the cooled acid is drawn off as product, but a considerable proportion is sent to the top of the Gay-Lussac tower to absorb oxides of nitrogen. The acid drawn from the base of the Gay-Lussac tower is called *nitrous vitriol*. This is taken to the top of the Glover tower; and in its passage down through the Glover tower the oxides of nitrogen are displaced and returned to the gas stream. Consequently, oxides of nitrogen that are added merely serve to make up losses and are only a small fraction of the total amount of oxides of nitrogen in the system. If the plant produces only 50° acid, chamber acid is withdrawn as the principal product and is not sent to the Glover tower. In such cases, water is fed to the top of the Glover tower to supply the water that would otherwise be added in the form of chamber acid.

Sulfur Burners.—A successful sulfur burner must fulfill several requirements. As a consequence of the low heat of combustion and the high vapor pressure of sulfur, the burner must expose a large surface of molten sulfur; minimize loss of heat by radiation; provide secondary air in the zone of high temperature to burn sublimed sulfur; and facilitate the removal of non-combustible floating impurities such as ash and asphaltic matter.

These conditions are met in a wide variety of apparatus. Possibly the simplest sulfur burner consists merely of a large brick chamber. A cast-iron pan about 5 inches deep, into which sulfur may be charged, is set in the front of this chamber. The pan should have an area of about 30 square feet per ton of sulfur burned per day. Air for primary combustion is admitted over the pan. This air not only burns sulfur in the pan, but carries from the pan considerable sulfur vapor which burns in the rear of the chamber. Secondary air is admitted under the pan and mixes with the primary products in the rear. By regulating the distribution of air from these two inlets, it is

possible to control the temperature of the molten sulfur, and introduce any desired proportion of secondary air.

The older burners, in which the pan was set on the floor, were not successful because it is not possible to secure complete combustion if all the air is admitted as primary air. As the quantity of air entering over the sulfur is increased, this merely increases the total quantity of sulfur burned and sublimed. At any given temperature, there will be an equilibrium between air and sulfur, in accordance with which the air will carry a certain proportion of sulfur vapor. Increasing the volume of primary air increases the quantity of air which can carry sublimed sulfur. This also increases the rate of combustion, thereby increasing the temperature and consequently the vapor pressure of the sulfur, with correspondingly increased sublimation.

The Glens Falls sulfur burner (Fig. 13) consists of a horizontal steel cylinder with conical ends, revolved on two sets of rolls at a rate of $\frac{1}{2}$ to $\frac{2}{3}$ r.p.m. Sulfur is fed at one end through a wormfeed mechanism, and primary air is admitted at the same place. The heat of combustion melts the sulfur within the cylinder. The rotation of the cylinder distributes this sulfur in a thin film on the inside of the apparatus, and also causes it to shower in drops through the hot gas. The discharge end of the cylinder fits into a combustion chamber, and secondary air to burn sublimed sulfur is introduced here by a sliding

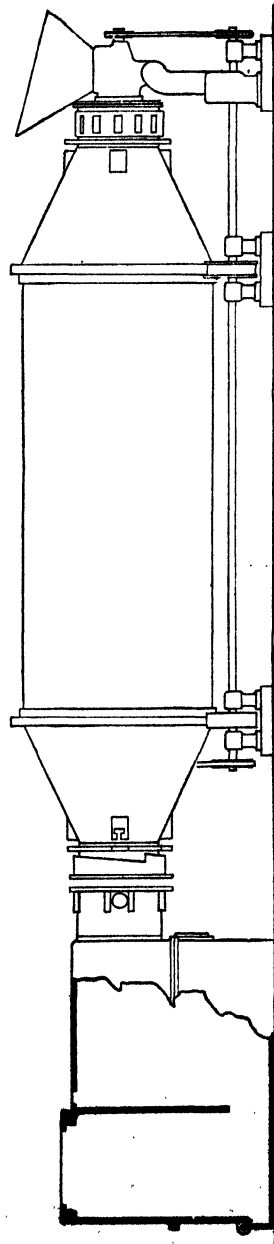

Fig. 13.—Glens Falls sulfur burner.

damper. The agitation of the sulfur prevents the formation on its surface of a film of impurities that might slow down combustion. The cylinders vary from 20 inches by 4 feet to 4 feet by 20 feet; and have a capacity of one ton of sulfur per 24 hours for each 24 cubic feet of cylinder volume.

The most recent tendency in sulfur burners has been to avoid complicated mechanical construction of the burner itself and to put the principal emphasis on subdividing the sulfur to give a large surface for combustion. One type⁽⁶⁾ consists of a vertical steel cylinder, lined with firebrick and divided with a perforated firebrick arch about a third of the way down. Sulfur is melted in a pit heated by steam coils and is raised to a temperature at which most of the water is driven off. Coarse dirt accompanying the sulfur settles at the bottom of the pit. The molten sulfur is pumped to the burner and cascades down over a conical pile of firebrick carried on top of the arch. Below the arch is a second cone onto which residual unburned sulfur falls. The air, which is predried, enters under pressure through flues, one near the sulfur inlet and one at the level of the arch. This burner is reported to give remarkably complete combustion with a minimum of vaporized and unburned sulfur in the gases.

The Zeisberg spray burner⁽¹⁾ also operates with premelted sulfur and predried air under pressure. The sulfur is atomized in a specially constructed steam-jacketed jet, and the flame impinges against a baffle wall of firebrick. The hot gases pass over the tubes of a boiler, thus generating steam and cooling the gases. In order to obtain reasonable boiler efficiency, the burner is operated to produce gas of about 14 per cent SO_2 , but this is diluted with additional air after passing through the boiler to concentrations suitable for acid manufacture.

Pyrite Burners.—The type of burner that is used depends upon the size of the pyrites, since coarse lumps and fine material require different types of burners.

Lump pyrite burners are simply brick-lined fire boxes about 6 feet long and 4 or 5 feet wide, with grates constructed of straight square bars. Since the production of uniform gas and the yield of a maximum amount of sulfur dioxide requires careful attention to the fires, the individual furnaces are made small. The heat of combustion of pyrites is low and hence it is essential that radiation losses be minimized. The furnaces are therefore set in bat-

teries, each battery consisting of two rows, back to back, with a flue between. In order to secure uniform and complete combustion, the depth of fire bed must be considerable and the air must be preheated. Preheating of the air is accomplished by maintaining a layer of hot cinders on the grates. About 50 square

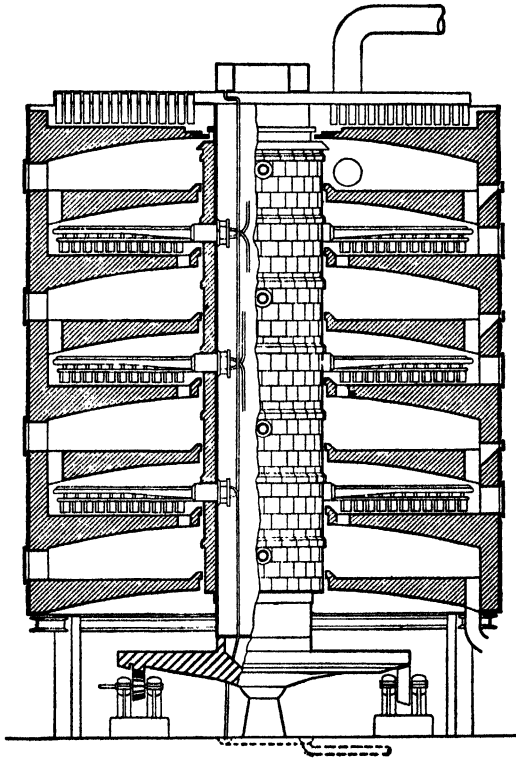

FIG. 14.—Burner for fine pyrites.

feet of grate area is required to burn one ton of 45 per cent sulfur ore per day.

Hearth burners for fine pyrites have been made in a wide variety of designs. The principal features are shown in Fig. 14. The furnace consists of a brick-lined steel shell in the form of a vertical cylinder 10 to 25 feet in diameter, in the axis of which stands a slowly rotating shaft. In the interior of this cylinder are constructed a number of superimposed firebrick hearths. The central shaft carries two or more arms for every hearth.

Rabbles on these arms are set at such an angle that they draw the ore toward a central opening in every alternate hearth, and push it toward an opening near the circumference of the other hearths. The shaft and the rabble arms are cooled, and the different designs differ in the method of cooling, the provisions for making repairs, and similar details. Most of the air for combustion is introduced at the bottom hearth and rises counter-current to the flow of material. The air is preheated by the burned cinders on the lower hearth. Combustion takes place on the intermediate hearths and the descending pyrites are preheated by the hot gases on the upper hearth. If the burner temperature becomes too high, additional air is introduced at intermediate hearths. These furnaces require about 100 square feet of hearth area per ton of ore per day.

In many metallurgical operations where pyritic ores are concentrated, pyrites are available in the form of relatively fine material. One method that has been employed for burning such material is the flash burner.⁽⁷⁾ The fine concentrate, as received, is fed into a ball mill through which primary air for combustion is blown. The purpose of this mill is not to grind the material but to suspend it in the stream of air. This stream of air and fine pyrites is blown into the center of the top of a vertical cylindrical combustion chamber with a hopper bottom. Most of the cinder falls from this hopper onto a conveyer, and secondary air enters through the gap between the hopper and the conveyer. The gas offtakes are near the top, so that the flame travels downward through the center of the chamber and up along the walls.

Because of the presence of finely divided iron oxide, which can act as a catalyst for the conversion of sulfur dioxide to SO_3 , it is necessary to cool the gas rapidly to a temperature at which this reaction cannot take place. It therefore passes first through small dust catchers, and then through a steam boiler, which reduces its temperature to about 350°C . It is then washed and scrubbed in the usual way.

In order to prevent too high conversion to SO_3 and too rapid destruction of the brick lining of the combustion chamber, it is necessary that the temperature of the combustion space be kept at about 1000 to 1100°C . The combustion of the pyrites would normally produce a temperature higher than this and, therefore, a part of the cooled burner gas is returned to the ball mill to dilute

the products of combustion and thus control the temperature in the combustion space.

Burner Gas.—Experience has shown that the best results in the chamber plant are obtained when the gas from the sulfur burners contains 8.5 to 9.0 per cent sulfur dioxide. This corresponds to 12.0 to 12.5 per cent free oxygen. In the burning of pyrites, part of the oxygen of the air is combined with the iron. Maintenance of the proper ratio of sulfur dioxide to oxygen, therefore, results in pyrites burners being operated to give a gas of 7.0 to 7.5 per cent sulfur dioxide. In both the above cases, sufficient excess oxygen is left in the burner gas so that the waste gas from the process carries 8.5 to 9.0 per cent oxygen.

Niter Supply.—The former method of replacing losses of oxides of nitrogen was to charge sulfuric acid and sodium nitrate, in approximately equimolecular proportions, into a cast-iron vessel known as a *niter hog*. This was set in the flue carrying the hot gas from the burner to the Glover tower, to supply the heat to carry out the reaction and vaporize the nitric acid. When the nitric acid vapor mixed with the burner gas, it was reduced. The reaction is probably



Since 1926–1927, practically the only method in use in the United States for supplying oxides of nitrogen to the chamber process has been by the oxidation of ammonia^(4,5) (see page 98).

In this process a mixture of ammonia and air is passed over heated platinum gauze, and if the proper conditions are maintained the nitrogen of the ammonia is almost quantitatively oxidized to NO. The apparatus is compact and easily operated. The supply of oxides of nitrogen to the process can be accurately and instantly regulated by turning a single valve; and at present prices of ammonia and saltpeter, it is much cheaper than the older methods.

The apparatus consists of a blower for furnishing air, a catalyst chamber, and a heat interchanger. If liquid ammonia is used, the air is preheated in the heat interchanger, and the ammonia is introduced through a control valve just before the mixture enters the catalyst. The heat of reaction is sufficient to preheat the incoming gases to the reaction temperature. If aqua ammonia is used, the air first passes up a small column down through

which aqua ammonia is passed. The mixture of air and ammonia is then preheated, but to avoid decomposition of the ammonia the heat exchanger must be made of nickel or aluminum.

The losses of oxides of nitrogen in the whole process, calculated as sodium nitrate, amount to about 4 per cent of the total weight of sulfur burned. This holds true for plants operating on sulfur or a good grade of pyrites. Plants operating on metallurgical gases of varying compositions may use as high as 8 or 9 per cent sodium nitrate. The niter loss also varies with the method of plant operation, since forcing the plant to high capacities results in a proportionately increased loss of oxides of nitrogen. With uniform operation at moderate rates the loss may be held down to 2 per cent.

Dust Collectors.—When pyrites are burned, if the fine material carried over with the gases were not removed, it would soon clog the Glover tower. The usual method is to introduce, between the burners and the Glover tower, a chamber whose cross-section is considerably larger than the gas flue. This chamber may be empty and depend merely on a decrease in gas velocity to drop the suspended particles; or it may be provided with baffles. The cross-section should be such as to reduce the gas velocity to about 3 feet per second, and it should be long enough to give the gases a total time in the chamber of 0.5 to 0.75 minute.

In some plants, especially those operating on smelter gases, the Cottrell system of electrical precipitation is used. This requires cooling and humidification of the gases. It consists in passing the gases through paths of relatively small cross-section, each carrying a central electrode. Between this electrode and the wall of the conduit a high-potential unidirectional electrostatic field is maintained. The solid particles are electrified and attracted to one of the poles. Provision is made for jarring the electrodes at intervals so that the accumulated dust falls into a hopper below.

The Glover Tower.—From a study of Fig. 12 and the description that accompanies it, it will appear that the Glover tower has several functions. Among these may be mentioned:

1. Cooling the burner gases.
2. Concentrating chamber acid.
3. Returning to the system oxides of nitrogen that have been recovered in the Gay-Lussac tower.

4. Supplying water vapor to the first chamber.

Before proceeding to a more detailed discussion of these it will be necessary to consider some reactions of general importance. The reactions that take place in the chamber process have been the subject of many controversies, but the theory advanced by Lunge⁽⁸⁾ has had the widest acceptance and has withstood criticism. Nevertheless, it is not complete, and there are many details of the operation of the chamber process that are not yet fully understood. According to Lunge, a very important place is held by a compound called nitrosyl-sulfuric acid, whose relation to sulfuric acid is shown by the following structural formulas:

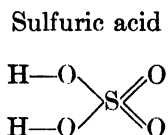
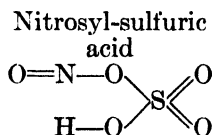

In the presence of sulfur dioxide and some free oxygen, this acid can be formed by the following reaction:

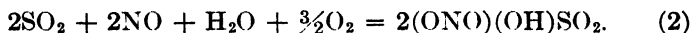

This compound is easily hydrolyzed, liberating sulfuric acid and N_2O_3 according to the reaction

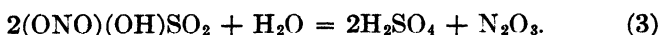

It is also easily reduced by SO_2 according to the reaction



High temperatures not only favor a more rapid rate of reaction, but also give an equilibrium corresponding to more complete decomposition of the nitrosyl-sulfuric acid. It is obvious that both reactions (2) and (4) are favored by high concentrations of sulfur dioxide; reaction (2) taking place where concentrations of NO are high, and reaction (4) where they are low.

It will be apparent, therefore, that the Glover tower is adapted to accomplish the recovery of nitrogen oxides from Gay-Lussac acid by hydrolysis in the upper part of the tower, and by reduction by means of sulfur dioxide in the lower portions of the tower. Gay-Lussac acid is fed into the top of the Glover tower

and in addition there is added the comparatively dilute chamber acid; or should the chamber acid be taken off as a separate product, water is added in its place. Hot burner gases entering the bottom of the tower and carrying a relatively high content of sulfur dioxide are able to decompose, according to reaction (4), any nitrosyl-sulfuric acid that may have reached the bottom of the tower. Thus, the acid issuing from the base of the Glover tower should contain only a trace of oxides of nitrogen. As the burner gas rises through the tower, it carries not only the nitric oxide supplied to the process, but increasing amounts of nitric oxide liberated from Gay-Lussac acid. This makes possible the direct synthesis of nitrosyl-sulfuric acid by reaction (2) at certain intermediate zones in the tower. Because of the high temperature of the gas it is able to concentrate the acid which it meets and, therefore, as it ascends, it also carries increasing concentrations of water vapor. This, combined with the dilution caused by chamber acid or water at the top, gives a zone in the upper part of the tower where nitrosyl-sulfuric acid is decomposed by hydrolysis. Thus, it will be seen that in addition to the functions previously mentioned, the Glover tower has another and very important one; namely, the synthesis of sulfuric acid. The acid formed in the tower may be as much as 20 per cent of the total output of the system.

The construction of the Glover tower varies considerably, but present practice favors a tower built of acid-proof brick, with or without a sheet-lead sheath, and resting in a lead pan (Fig. 15). On this lead pan is laid an acid-proof masonry floor, which supports the walls of the tower and also arches, which in turn support packing material with which the tower is nearly filled. A special distribution device at the top of the tower insures uniform wetting of the packing with the acid. Thus the liquid is filmed out over the packing material in the tower while the gas is forced to pass up through this packing, and the two phases are brought into intimate countercurrent contact.

All the reactions taking place in the Glover tower involve the interaction of a liquid and a gas. At the high temperatures of the Glover tower all these reactions are very rapid and a relatively short time of contact is sufficient. Consequently, a rather coarse packing with relatively large free spaces is satisfactory. The packed section should be 30 to 40 feet high. Ordinary practice

calls for a gas velocity (figured at standard conditions) of approximately 0.8 foot per second. These height and velocity figures correspond to a packed volume of 0.07 cubic foot per pound of sulfur burned per day.

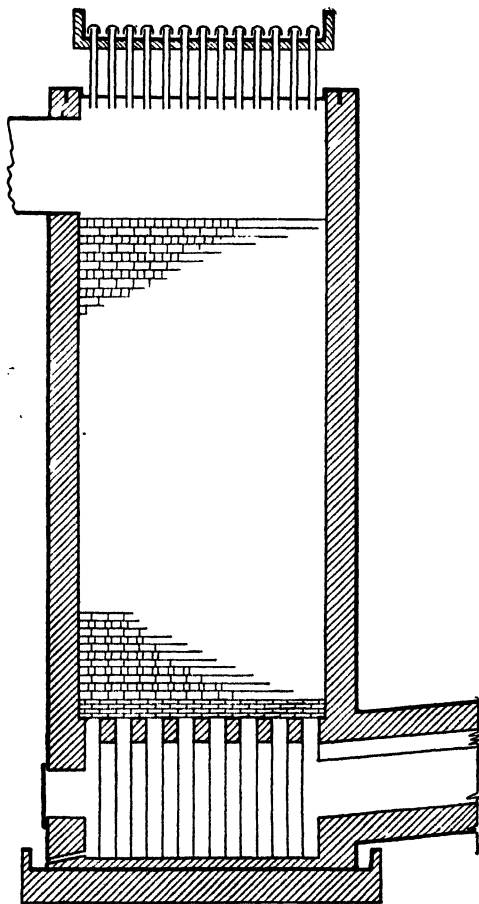

FIG. 15.—Details of chamber-plant construction: Glover tower.

Lead Chambers.—The lead chambers are essentially large vessels that allow space, and therefore time, for the major reactions to take place before the gases leave the system. The gases entering the first chamber from the Glover tower contain water vapor and a relatively high concentration of sulfur dioxide and free oxygen. The oxides of nitrogen at this point are almost

entirely NO, as shown by the fact that the contents of the first chamber are usually without any trace of red oxides.

The reactions by which sulfuric acid is made in the chambers result in the evolution of heat, so that the central portions of the chambers are always warmer than the outer portions, which are exposed to the cooling influence of the surrounding air. The chambers are filled with small floating particles of mist that circulate about with the chamber gases, rising in the central portions of the chambers and falling near the sides. These mist particles consist of nitrosyl-sulfuric acid and sulfuric acid of varying dilutions. Since the partial pressure of water vapor within a given chamber is more or less uniform, and since these particles are hotter in the central portion of the chamber, they will, therefore, be more concentrated in the central part of the chamber and more dilute toward the walls. In the central areas sulfur dioxide, nitric oxide, and oxygen can unite to form nitrosyl-sulfuric acid; whereas at the walls, where the temperature is lower, water vapor condenses on the drops, diluting them, hydrolyzing the nitrosyl-sulfuric acid, and liberating oxides of nitrogen. Any N_2O_3 liberated will recombine with great rapidity with sulfur dioxide and water, forming more nitrosyl-sulfuric acid; for the gas in the first chamber is substantially colorless.

Much of the difficulty in assembling a coherent theory of the chamber process centers around the question of which oxides of nitrogen are present and what their various functions may be. The oxides of nitrogen involved in the process are commonly considered to be three in number; NO which is colorless, NO_2 which is reddish, and N_2O_3 which is deep red. At the temperature of the chambers, N_2O_3 cannot exist except in very small concentrations. If it is formed by the hydrolysis of nitrosyl-sulfuric acid it must almost completely dissociate according to the reaction



That NO_2 , except such as results from this dissociation, does not enter into reactions in the chambers, is evidenced by the fact that an excess of NO_2 over NO is never found in the chamber gases. Any NO_2 that is present probably reacts not as such, but by combining with NO to form N_2O_3 . Consequently, the assumption that only NO and N_2O_3 or its equivalent are present, gives a satisfactory explanation of the reactions in the chambers.

It has been observed that the contents of the earlier chambers are white or colorless, while the later ones show an increasing reddish color. This indicates the absence of N_2O_3 from the first chamber. This is usually explained by assuming the formation of nitrosyl-sulfuric acid according to the equation

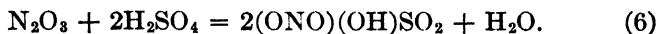

As the gas proceeds through the chambers, its temperature is lowered and at the same time the sulfur dioxide concentration is decreased, the decomposition of nitrosyl-sulfuric acid according to equation (4) decreases, its hydrolysis by water with the formation of N_2O_3 increases, and thus the increasing color is explained. Equation (2) calls for the synthesis of nitrosyl-sulfuric acid by nitric oxide and oxygen. In the presence of lower concentrations of sulfur dioxide and at lower temperatures, the NO in this equation may be replaced by N_2O_3 as follows:

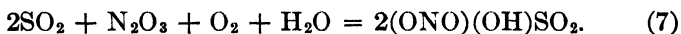

It has been stated above that at temperatures existing in the chambers N_2O_3 exists only in very small concentrations. The residual concentration of N_2O_3 at equilibrium is sufficient for reaction (7), thereby removing N_2O_3 from the gas phase and causing NO and NO_2 to react with the formation of more N_2O_3 .

The reactions that have been discussed result in the removal of water from the chamber gases to form sulfuric acid. The water vapor supplied by the Glover tower is usually sufficient for the first chamber, but in succeeding chambers water must be added as steam or fine spray.

Chamber Construction.—The usual lead chamber is a rectangular vessel of sheet lead supported on a suitable framework. These chambers may be 50 to 150 feet long, 16 to 26 feet high, and 20 to 30 feet wide. There are usually three to six chambers; and they may all be of the same size, but it is more common to make the first chamber longer than the others. For a given method of working, the total capacity in cubic feet of chamber space per pound of sulfur burned is fairly constant.* The older chambers had a wood framework, but modern construction employs steel. Because of the tendency of lead to crawl (deform beyond the elastic limit) it must be fastened securely at frequent intervals. This is usually accomplished by burning tabs of lead

* See p. 58.

to the side walls at intervals not less than 3 feet apart each way, and securely fastening these tabs to the supporting framework (Fig. 16). The top of the chamber is hung in a similar manner.

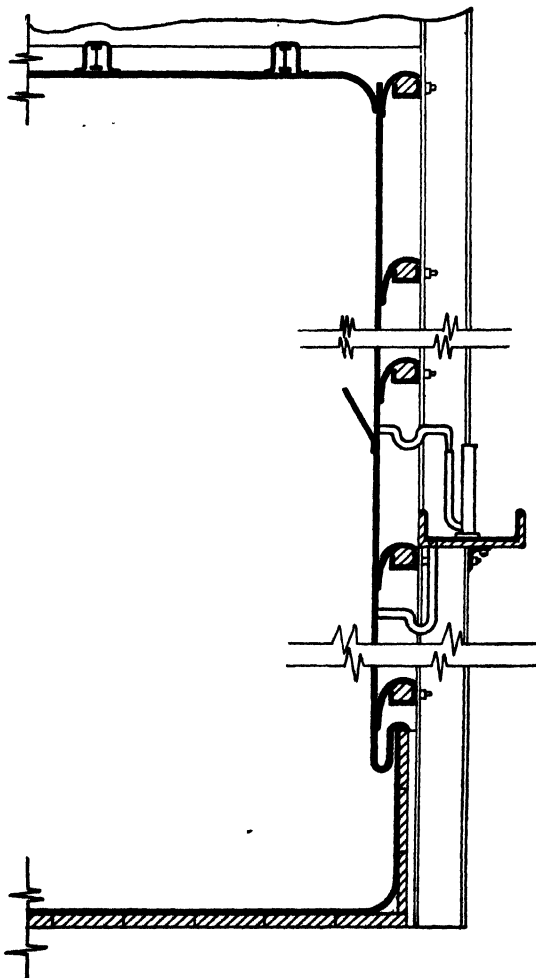

FIG. 16.—Details of chamber-plant construction: chamber construction.

Through the top project spray nozzles for the introduction of steam or, preferably, water mist. The bottom of the chamber is a pan with upturned edges which are burned to the bottoms of the side walls. At intervals along the side walls a gutter is burned on

the inside with a small connection to the outside of the chamber. A portion of the acid condensed on the chamber walls drains into this gutter and drips from a spout outside the chamber. The density of these drips, together with the temperatures of the chambers, furnishes the information by which the process is usually controlled.

Gay-Lussac Tower.—If the chambers are properly operated there will be a very small concentration of sulfur dioxide in the gas leaving the final chamber, and there should have been no loss of oxides of nitrogen up to this point. Since the Gay-Lussac tower is fed at the top with cold 60° acid, conditions are favorable to reaction (6). It is obviously important that the concentration of sulfur dioxide be kept low, otherwise equation (4) would take place with loss of oxides of nitrogen. On the other hand, if the sulfur dioxide be exhausted before the gas leaves the last chamber, nitric acid will form in the last chamber, condensing on the chamber walls and corroding them. Exhausting the sulfur dioxide will also permit the excess oxygen, required for the chamber reactions, to oxidize nitric oxide to nitrogen dioxide in excess of that corresponding to N_2O_3 . The excess nitrogen dioxide will not form nitrosyl-sulfuric acid, and is only slightly soluble in sulfuric acid. The function of the Gay-Lussac tower is relatively simple and is represented in normal working by equation (6). Some oxides of nitrogen are always lost from the top of the Gay-Lussac tower, due partly to the presence of SO_2 [equation (4)], partly to inability to carry equation (6) to completion, and partly to the presence of an excess of NO_2 .

The Gay-Lussac tower is usually about the same in cross-section as the Glover tower, but since the temperature is low and the reactions are less rapid, a longer time and a more intimate contact between gas and liquid are required to bring them even approximately to completion. Therefore, the packing is finer than in the Glover tower so as to expose more surface per unit volume, and the length of this packed space is usually at least twice that of the Glover tower. Since it is inconvenient to build a single tower so high, there are usually two Gay-Lussac towers operating in series. The total length of the packed section in the Gay-Lussac tower is about 70 feet (two towers of 35 feet each). With usual packings, these figures correspond to a time of contact of liquid and gas of about 50 seconds* and a lineal

* For packing having 50% free volume.

velocity of gas through the empty tower of about 0.6 foot per second, at standard conditions.

The volume of 60° acid pumped over the Gay-Lussac tower is one to three times the volume of acid made in the chambers, the actual quantity being so adjusted that the acid leaving the tower will contain 1 to 2.5 per cent of N_2O_3 by weight. More intensive working of the chambers, which requires a higher concentration of oxides of nitrogen in the chambers, will therefore require more acid for the Gay-Lussac.

Movement of Gases.—It is necessary to provide some means for moving the gases through the chambers and towers and creating a draft for the burners. This may be done by interposing a fan at some place in the system, as between the burners and the Glover tower, or on the exhaust gases from the Gay-Lussac tower. In place of a fan, the gases from the Gay-Lussac tower may be conducted into the boiler stack. This has the advantage of eliminating the maintenance of fans.

Transportation of Acid.—Since very large quantities of acid must be handled in a chamber plant of even moderate size, the apparatus for moving this acid is of importance. One very simple device, formerly used almost entirely and still extensively used, is the acid egg or blow-case. Most modern plants handle acid entirely with centrifugal pumps. These pumps are available in a number of designs, either in hard lead or Duriron, and have proven entirely satisfactory. Sixty-degree acid or stronger, free from dissolved oxides of nitrogen, can be handled in specially designed cast-iron centrifugal pumps.

Coolers.—The hot 60°Bé. acid from the base of the Glover tower must be cooled. The coolers consist of a series of water-jacketed lead tubs, filled with lead cooling coils. This design of cooler facilitates the removal of sulfur carried from the base of the Glover tower; and as the Glover acid is quickly mixed with partially cooled acid, corrosion of the lead is minimized.

Special Systems.⁽⁹⁾—In the previous discussion, it has been developed that acid formation in the chamber process depends on the mixing of gases and spray in the chambers, and on the dissipation of the heat liberated by the reaction. In the ordinary lead chambers, mixing takes place chiefly by diffusion and convection, and the heat of reaction is dissipated by radiation from the walls to the surrounding air. Such chambers use from 6 to 12

cubic feet of chamber space per pound of sulfur burned per 24 hours. It is obvious that the rate of reaction could be increased and the amount of chamber space decreased if devices were added for mixing the gases, for removing heat, or for bringing the gas and liquid phases more thoroughly into contact with each other.

A number of systems have been devised for accomplishing some of these aims. None of them has been adopted to the exclusion of the standard process, and some of them have found very little recognition. The only one that has met with great favor in the United States is the Mills-Packard system. It employs lead chambers in the form of truncated cones, of 7,000 to 18,000 cubic feet each. The particular feature of the process is that a film of water is allowed to trickle down the outer surface of these cones to remove the heat of reaction. This results in rapid cooling and condensation on the inner surface of the chambers, so that Mills-Packard systems operate with 3 to 5 cubic feet of chamber space per pound of sulfur burned and a niter rate of about 3 per cent.

Purification of Sulfuric Acid.—When acid of high quality is desired, it is usually sufficient to specify that it be made from brimstone. If acid of the highest purity is needed, it can be obtained by specifying that it must be made by the contact process. The very rigorous purification that the gas receives in the contact process means that contact acid will always be appreciably purer than chamber acid. In some cases where chamber acid is made from pyrites or blende, it may have to be treated to remove arsenic.

This is best carried out by passing hydrogen sulfide through acid of 50 to 53°Bé. It may be done in towers, or in special apparatus in which rapidly rotating paddles subdivide the acid and bring it into contact with the gas. The sulfide precipitate is then removed by sand or coke filters. There are uses for impure acid, and in most plants in the United States, purification is not necessary.

CONCENTRATION OF SULFURIC ACID

Usually, chamber plants are so located that they dispose of most of their acid at 53 or 60°Bé. The demand for acid of 66° or stronger is usually met with contact acid. There are cases, however, where it is desirable to concentrate either chamber acid

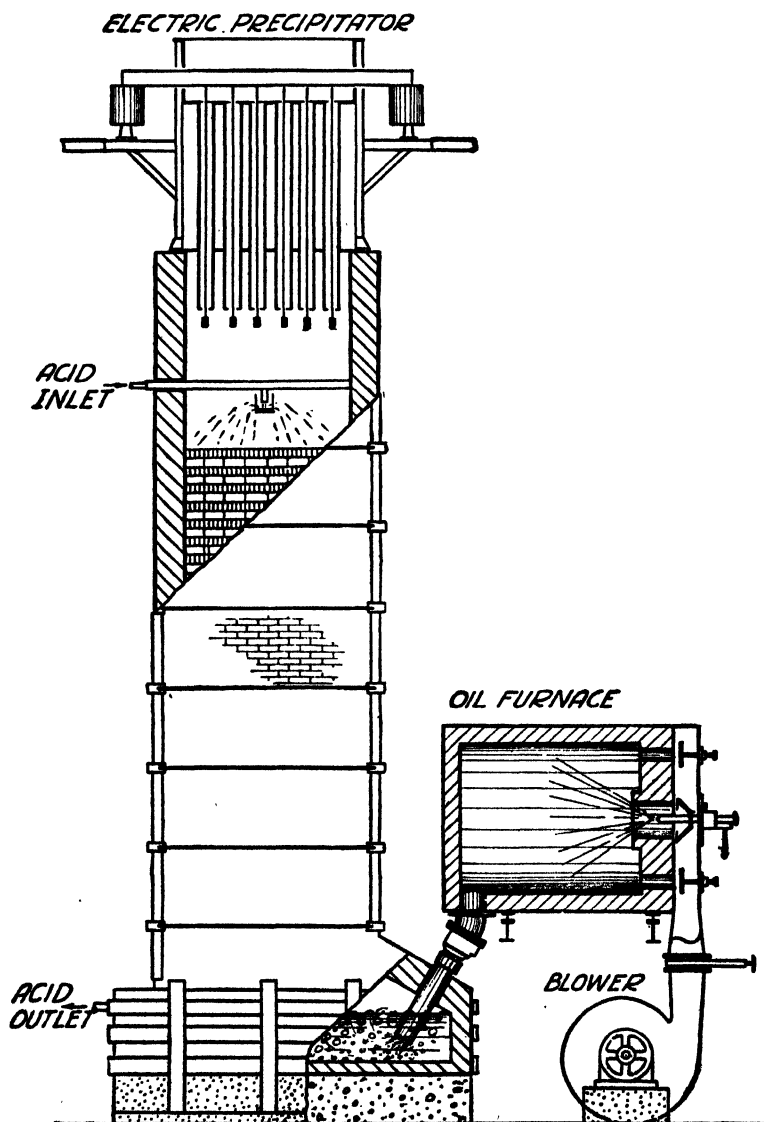

FIG. 17.—Chemico concentrator for sulfuric acid. (Courtesy Chemical Construction Company.)

or Glover tower acid to 66°. This is usually done by methods in which hot gases are brought into direct contact with the acid; and may be illustrated by the Chemico concentrator (Fig. 17).⁽⁹⁾ Other variants of this system differ only in structural details.

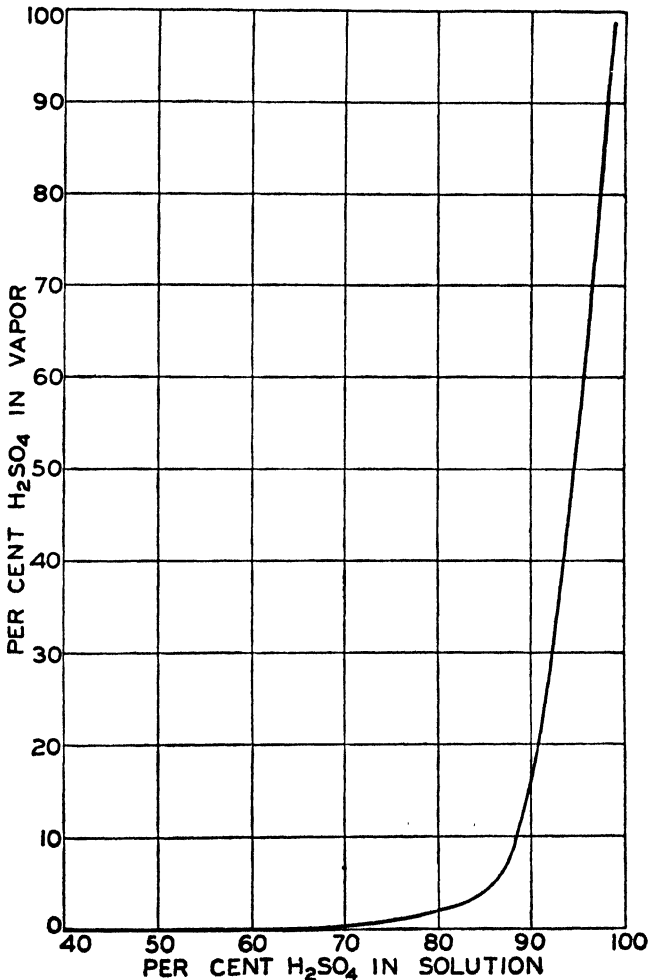

FIG. 18.—Concentration of sulfuric acid in vapor at the boiling point.

The acid to be concentrated is fed at the top of the tower. The tower is filled with quartz or stoneware packing; and delivers the acid at the bottom to a pan. This pan is lined with acid-

proof masonry, and is heated by the products of combustion from a gas or oil burner. At the back of this pan the concentrated acid overflows to coolers and a storage tank. The gas leaving the top of the tower contains considerable sulfuric-acid mist, and is therefore conducted through a Cottrell electrical precipitator. The acid collected by the precipitator drains back into the tower.

Tower concentrators are similar in operation to a Glover tower, and have a correspondingly large capacity with low cost of maintenance. When fired with gas or oil, the purity of the acid is not decreased in passing through the concentrator, and the product may be water-white if the tower is fed with chamber acid.

Figure 18⁽¹⁰⁾ shows the equilibrium concentration of sulfuric acid in the vapor phase, corresponding to various concentrations in the liquid phase, at the boiling point at one atmosphere. It will be apparent that the vapor from boiling 66°Bé. acid would contain about 30 per cent sulfuric acid, whereas the vapors from 50°Bé. acid will be acid-free. Inert flue gas in the tower system lowers the partial pressure of the acid vapor and therefore concentration takes place at much lower temperatures. This results in a lower concentration of acid in the gas phase than that called for by Fig. 18. Tower concentrators possess a further advantage in that they function in much the same manner as a rectifying column. Acid vaporized in the lower part of the tower is largely absorbed in the cooler and more dilute acid descending in the upper portions of the tower.

Sludge Acid Concentration.—In the petroleum industry considerable quantities of *sludge acid* are produced. This is acid that has been used to treat various petroleum fractions and contains organic material dissolved in the form of sulfonates or suspended in the form of emulsions. Sufficient quantities of this material are produced so that it must be reconcentrated. Various other organic industries may produce waste acid contaminated with organic matter. Such materials are usually recovered, not so much because of the value of the acid as to eliminate waste-disposal problems.

One common form of concentrator is shown in Fig. 19. It consists of a horizontal, cylindrical steel shell lined with acid-proof brick. This is divided into a furnace chamber at one end and two concentrating chambers at the other end. The furnace is

fired with oil or gas under sufficient pressure to cause the hot products of combustion to bubble directly through the material to be concentrated in the other two chambers. The weak acid is fed into one of the concentrating chambers and then flows by gravity into the other. The reason for this separation is that the weak acid very often foams, possibly due to a reduction of the acid to sulfur dioxide by the organic matter which may reduce the yield to 70 to 75 per cent of the acid entering.

The gases pass from the drum into which the dilute acid is fed, to a mist separator. This consists of a short layer of packing

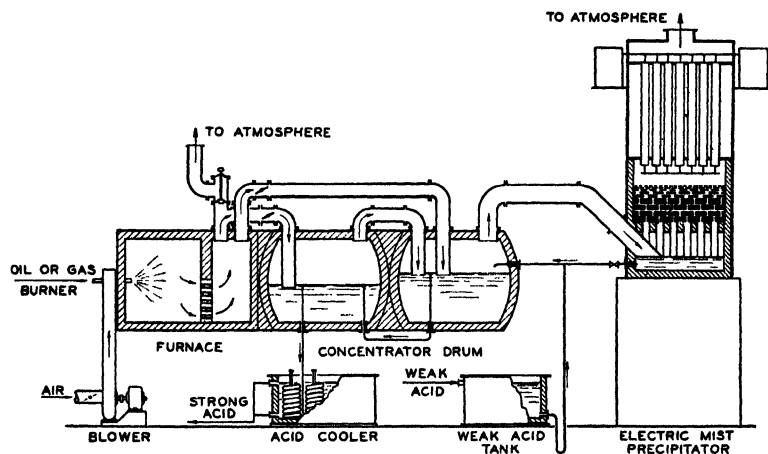

FIG. 19.—Concentrator for sludge acid. (Courtesy Chemical Construction Company.)

supported on acid-proof brick arches and followed by a Cottrell electrostatic separator.

Various other types of sludge acid concentrators are in use, in at least one of which the acid is concentrated at a high vacuum by means of high-pressure steam in lead coils or in tubes of high-silicon iron. Originally, this concentrator was run with a vacuum of about 28 inches. This took steam up to 250 pounds and did not result in the highest concentration of acid. The particular difficulty, however, was that under a vacuum of 28 inches the temperature of the acid was high enough to cause a reaction between the organic matter and the acid, resulting in foaming and loss of acid by reduction. Later, these concentrators were run under very high vacuum (5 to 10 millimeters). This gives, first,

a low enough boiling point so that 120-pound steam can be used and, second, a low enough boiling point so that there is no reduction of the acid by organic matter. Yields are of the order of 95 per cent of the incoming acid.

Sometimes special steps are taken to break emulsions or to coagulate the organic matter, thus leaving an acid containing less organic matter to go to the concentrators. The organic material is either discarded, or, if large quantities are available, it may be treated by a process in which all the acid it contains is reduced to sulfur dioxide and this is then sent to a contact plant. The carbon dioxide in this gas is objectionable in the contact plant only because it lowers slightly the concentrations of sulfur dioxide and oxygen.

THE CONTACT PROCESS

Many industries, especially those organic industries that involve nitrations, require high concentrations of sulfuric acid. While 66°Bé. acid may be obtained by the concentration of acid from the chamber process, sulfuric acid of 100 per cent or stronger cannot be made in this way. Such strong acids are made by absorbing sulfur trioxide in 66° acid. Sulfur trioxide was first obtained by the dry distillation of ferric sulfate or shale containing alum or other heavy metal sulfates. Difficulties in the production of large amounts of sulfur trioxide by these methods created a demand for a method for making it directly from sulfur or pyrites. The successful development of the oxidation of sulfur dioxide directly to sulfur trioxide, which was accomplished between 1890 and 1900, laid the foundations for what is now known as the contact process for the manufacture of sulfuric acid. The design of a successful contact acid plant was accomplished, however, only after a satisfactory understanding of the equilibrium between sulfur dioxide and sulfur trioxide.

Theory of the Contact Process.—From a consideration of the equation



it is obvious that at equilibrium the relative concentrations of the reacting substances at any particular temperature, are defined by

$$K = \frac{P_{\text{SO}_3}}{P_{\text{SO}_2}} \times \frac{1}{\sqrt{P_{\text{O}_2}}}, \quad (9)$$

where these pressures refer to the partial pressures of the various gases, expressed in atmospheres, after equilibrium is obtained.⁽¹¹⁾

This reaction is exothermic and consequently an application of Le Chatelier's theorem shows that the position of the equilibrium must shift with increasing temperature in such a way as to call for lower conversions of sulfur dioxide to trioxide. If the heat of the reaction at any one temperature and the specific heats of the reacting substances are known, it is possible to calculate the variation of K with temperature fairly accurately. With the best values for the constants it is found that

$$\log_{10} K = \frac{8,775}{t} - 4.46 \quad (10)$$

where t is temperature in degrees Rankine. Table X presents a series of values of K calculated from this equation and corresponding experimental values obtained by Knietsch and Bodlander.

TABLE X.—EFFECT OF TEMPERATURE ON EQUILIBRIUM CONSTANT IN THE CONVERSION OF SO_2 TO SO_3

$t^\circ \text{C.}$	$t^\circ \text{F.}$	t° Rankine	K calculated	K observed	Observers
450	842	1,302	191.4	187.7	Knietsch
500	932	1,392	70.0	72.3	Knietsch
515	959	1,419	53.2	65.4	Bodlander
553	1,027	1,487	27.5	24.1	Bodlander
600	1,112	1,572	13.3	14.9	Knietsch
610	1,130	1,590	11.5	10.5	Bodlander
700	1,292	1,752	3.55	4.84	Knietsch
800	1,472	1,932	1.21	1.81	Knietsch
900	1,652	2,112	0.20	0.57	Knietsch

If 100 mols of burner gas containing a mols of SO_2 , b mols of O_2 , and c mols of SO_3 are brought into equilibrium at any given temperature, x mols of SO_3 will be formed. This will cause the disappearance of $0.5x$ mol of O_2 and x mols of SO_2 . If the total pressure is 1 atmosphere, the partial pressure of SO_3 in the resulting gas will then be

$$\frac{x + c}{100 - 0.5x},$$

because there has been a net contraction in volume of $0.5x$. In

the same way the partial pressure of SO_2 in the resulting gases will be $\frac{a-x}{100-0.5x}$, and of O_2 , $\frac{b-0.5x}{100-0.5x}$.

Substituting these values in the equation for K above we have the following:

$$K = \frac{x+c}{(a-x)\left(\frac{b-0.5x}{100-0.5x}\right)^{1/2}} \quad (11)$$

For a particular value of K the corresponding value of x is most simply found by the method of trial and error. Several values may be assumed for x and substituted in the right-hand member of this equation. That value of x which gives the desired value for K is the solution. Graphic interpolation may be used to shorten the work.

Rate of Reaction.—The above discussion is based on conditions that would obtain if equilibrium were reached, and says nothing about the time necessary to reach that equilibrium. Numerical data for these rates are still too fragmentary to include here,⁽¹²⁾ but all reactions increase in velocity considerably with moderate increases in temperature. In this particular case, even at temperatures above 1100°F ., the rate of reaction is very slow. Although at higher temperatures the reaction may be more rapid, equilibrium, if reached, is at low concentrations of sulfur trioxide. By the use of a catalyst, however, the velocity of the reaction can be increased, so that at low temperatures where favorable equilibrium conditions exist, practical operation is possible.

Many substances catalyze this reaction more or less. In burning sulfur, practically no catalyst is present and negligible amounts of sulfur trioxide are formed. In burning pyrites, the Fe_2O_3 acts as a catalyst to a certain extent and small amounts of sulfur trioxide appear in the burner gas. The best catalysts are porous masses containing either finely divided platinum or compounds of vanadium. With either of these, equilibrium can be substantially reached in a few seconds at temperatures from 750 to 850°F . Temperatures of this order correspond to an equilibrium so favorable that in actual practice conversions of 98 per cent or better are possible.

Sulfur Contact Plant.—The essential steps in a contact process plant using sulfur are (1) burning sulfur, (2) purification of the gas, (3) passing the gas over the catalyst, and (4) absorption in

sulfuric acid of the sulfur trioxide so formed. When sulfur is the raw material, the gas is sufficiently pure so that removal of water vapor and a simple filtration is all that is necessary. The filter is usually merely a layer of the same inert material that is used to carry the catalyst.

Figure 20 is a flow sheet of a somewhat idealized contact process plant burning sulfur. In actual practice no two plants are exactly alike, and there may be no plant that contains exactly the equipment shown in Fig. 20. Sulfur is melted and held at such a temperature that solid impurities settle and water is vaporized. This melted sulfur is then pumped to a sulfur burner which, however, must be supplied with dry air. This air is dried with strong sulfuric acid in a drying tower, and the blower which carries the pressure on the system is usually between the drying tower and the burners.

In Fig. 20 the gas is cooled and filtered before going to the catalyst chambers. These coolers are similar to those described on page 69. In more recent plants operating on sulfur, the sulfur burner may be followed by a waste-heat steam boiler instead of a cooler.

The conversion is carried out in two stages and there are usually two heat interchangers. Cool gas from the filter passes through both heat interchangers in series and then to the first converter at about 400°C. This converter operates at a higher average temperature, contains a relatively thin catalyst bed, and accomplishes most of the conversion. During this conversion heat is liberated, and the gas issues from the first converter at a temperature slightly under 600°C. It goes through one of the heat interchangers to give up some of its heat to the incoming gas stream, and then to the second converter at about the same temperature as at the entrance to the first converter. This converter operates at a lower average temperature, has a much deeper catalyst bed, and accomplishes the final conversion. From the second converter the gas, at about 460°C., goes through the second heat interchanger and finally to a cooler where it is brought down to a temperature of about 100°C. In starting up a cold plant, a direct-fired preheater may be interposed between the filters and the heat interchangers to start the operation, but this is cut out of the process as soon as the cycle comes up to temperature.

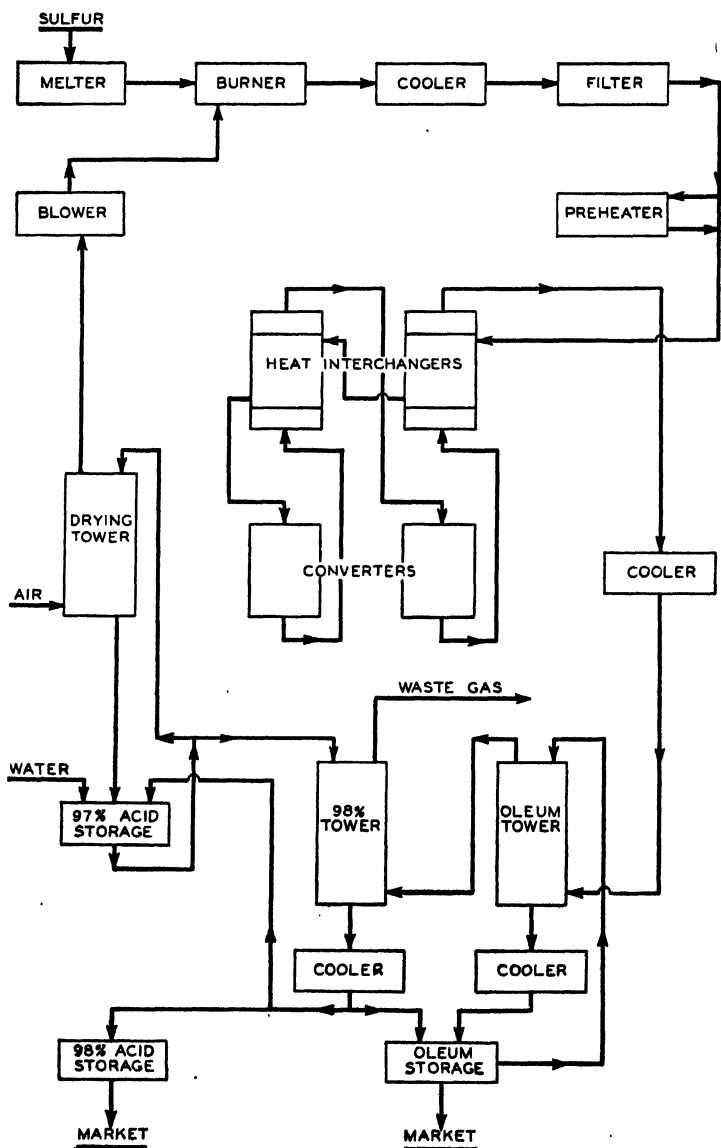

Fig. 20.—Flow sheet of contact process.

The gas, which now contains about 95 per cent of its sulfur as SO_3 , is absorbed in oleum and the feed of oleum to the tower is so regulated that a rise of not over 0.5 to 1.0 per cent in acid strength occurs in passing through the tower. All the SO_3 cannot be absorbed in such strong acid and, therefore, the gas goes next to a tower fed with about 97 per cent acid. The acid fed to this tower is so regulated that the acid strength increases about 1 per cent in passing through the tower. The product from this tower is cooled and part of it may be sold as such, part of it goes to oleum storage to be fortified in the oleum tower, and part of it is fed to the storage tank that supplies acid to the air-drying tower. This last storage tank may or may not have water added according to the amount of moisture present in the air.

In those plants where the gas is not cooled after the burner but passes through a waste-heat boiler, the boiler is operated so that the exit gas is at a proper temperature to be sent directly to the first converter. The heat-interchanger system then disappears and is replaced by a simple cooler, which cools the gas between the two stages of conversion. The preheater also disappears, and the system is brought up to operating temperature by firing oil or gas in the sulfur burner.

Pyrites Contact Plants.—Sulfur is preferred to pyrites as a raw material for the contact process because it gives a purer burner gas. Pyrites introduce into the gas dust, arsenic and other metallic oxides, and sometimes halogens. Consequently, the purification of gas from pyrites burners is always more complicated than a purification of sulfur burner gas. Where an elaborate purification system is to be employed, as in the treatment of gas from pyrites burners, the burner gas must be cooled to a rather low temperature before the purification system. This is done by passing the gas through unlined cast iron or steel pipe, usually arranged in either horizontal or vertical S-bends. This is usually designed to cool the gas to about 275°C ., at which point a hot Cottrell precipitator may be introduced. Beyond this the gas is usually cooled in lead, and these lead pipes may either be sprayed with water or partially sprayed and partially submerged in water.

No standard flow sheet can be drawn for the purification of pyrites gas because the methods employed are quite varied. They all employ, however, cooling, separating the dust (either in dust chambers or in Cottrell dust collectors), scrubbing with

sulfuric acid, and filtration. If halogens are to be removed, the scrubbing acid is usually under 55 per cent.

Although the scrubbing system gives nearly complete purification, it is necessary that the gas be absolutely free from suspended mist or solid particles. The usual way of removing these is by filtration. Various styles of filters have been used, but the most common one is a rectangular box of relatively large cross-section, lead lined, and filled with coke which has been carefully screened and washed. In a plant that makes 30 tons of acid per day the filter may be 30 to 40 feet wide, 50 to 60 feet long, and 15 feet deep. It should have a sloping bottom from which the acid which is collected may be drained. The coke should be graduated in size and may range from $\frac{1}{2}$ -inch lumps at the bottom to pieces as small as $\frac{1}{4}$ inch or even 10 mesh at the top. Small filter boxes packed with sawdust and asbestos fiber or mineral wool have also been used successfully.

The gas leaving the filter must be thoroughly dry. Unless strong acid was used in the scrubbing system, the final drying follows the filters and is usually done in a cast-iron tower, packed with quartz or stoneware shapes which are sprayed with 97 to 98 per cent acid. From here on the flowsheet of a pyrites plant is the same as Fig. 20.

Heat-transfer System.—After purification the gas is heated to the reaction temperature either by a direct-fired preheater or by heat interchangers. Since the gas is dry, these and subsequent units in the system may be made of steel. Cast iron is less suitable, as the graphite in it is acted on by hot sulfur trioxide. The heat interchangers are ordinary tubular heaters with steel shells and boiler tubes. The gas to be heated usually passes around the tubes. Baffles are placed inside the heater to prevent short circuiting, lengthen the gas path, and increase the rate of heat transfer. The gas which is supplying the heat passes inside the tubes and generally goes through all the tubes in parallel. The direct-fired preheater consists of a large number of boiler tubes connected in series and arranged in the flue of an oil or coke fire.

Catalysts.—The most vital part of a contact plant, and the one about which most discussions have centered, is the type of contact mass used. Originally this was always finely divided platinum and the processes were classified according to methods of

preparation of the catalyst or the construction of the catalyst chamber. At the present time in the United States the only two processes generally recognized are the platinum contact process and the vanadium contact process. There may be considerable differences in flow sheets and equipment between individual plants of each type, but none of these is of general significance.

Platinum contact masses usually consist of finely divided platinum suspended on asbestos mats or on granular silica gel. The amount of platinum used in modern plants is 4 to 6 Troy ounces of metallic platinum per ton of 100 per cent acid made per 24 hours. Although the first cost of the platinum seems high, this is largely offset by the fact that 90 per cent of the platinum can be recovered when the mass is discarded. The platinum contact mass can operate with higher gas concentrations, gives slightly higher conversions, and is possibly more flexible in operation than the vanadium mass.

There are several vanadium contact masses, covered by closely-held patents. The contact mass is sold by the holders of these patents in the form of porous granular material. About 20 pounds of the mass are used per ton of 100 per cent acid made per 24 hours. Although the actual cost of the vanadium compound and the preparation of the mass is a fraction of the first cost of the platinum, royalty charges at present make the equivalent first cost of the vanadium mass higher than that of the platinum mass.

The greater superiority of the vanadium contact mass is its freedom from *poisoning*. The activity of many catalysts is decreased, if not totally destroyed, by the presence of traces of materials called poisons. The platinum contact mass (at least, that on asbestos) is particularly susceptible to such poisons, the most serious of which are arsenic and fluorine. As a consequence of this, the gas for a platinum system must be very carefully purified, since 1 or 2 parts per million of arsenic in the gas will quickly destroy the activity of the catalyst. If the platinum has become poisoned, the catalyst mass must be removed and reworked. The apparent major advantage of the vanadium catalyst is that it is not subject to poisoning. However, the specifications for contact acid are such that the gas must be purified to an extent that neither catalyst would suffer from poisoning. Both types of catalyst are rendered inactive by dust.

Therefore the gas must be carefully filtered in either case. If dust gets into the catalyst mass, the mass must be removed and screened.

The balance of advantages and disadvantages of the platinum and the vanadium masses is at present a controversial subject.^(1,13) Advocates of the vanadium mass claim that its long life offsets its slightly higher first cost. Advocates of the platinum mass insist that with a properly operated plant the life of the platinum is long enough to make the net cost per ton of acid less than with the vanadium catalyst. They also point out that, whereas the vanadium catalyst works best on gases containing 7 to 8 per cent SO₂, the platinum catalyst operates satisfactorily on gas containing up to 10 per cent SO₂, thereby reducing the size of the equipment and the cost of the plant. Both types of catalyst are in use in a considerable number of plants in this country, with no indication of a general preference for either type.

Converters.—The converter, or chamber in which the catalyst mass is contained, is simply a cylindrical sheet steel shell, usually with a cone bottom. If the catalyst is platinum on asbestos, the shell contains a number of impregnated asbestos mats, 10 to 13 in a unit, supported by wire netting and held in a steel frame. If the catalyst is a vanadium mass, it is carried on wire screen or perforated metal in somewhat thicker layers.

In the case of a plant in which the sulfur burner is followed by a waste heat boiler so regulated that the gas may be fed to the converter at the proper temperature, the gas filter and the two stages of conversion may be combined in one shell. In this case the gas will enter the bottom of the converter, first through the filter, then through the first catalyst bed, out to a cooler, and then back to the second catalyst bed.

Another method of controlling the temperature of the reaction is to embed a series of vertical tubes in the catalyst bed. Through these tubes air is blown; and the amount of this air is so controlled that the average temperature of the catalyst bed is kept at the desired point. In one type of apparatus these tubes may serve as heat interchangers.

Absorption Systems.—The oleum absorption towers are usually constructed of a sheet steel shell, lined with removable sections of cast iron or with acid-proof brick, and packed with quartz or stoneware shapes. The 98 per cent absorption towers are

usually cast-iron towers similarly packed. The acid coolers both for oleum and for 98 per cent acid are made of cast-iron pipe, which carries the acid in the annular space between it and a smaller cast-iron pipe supplied with cooling water.

The absorption towers may be fed with acid of any strength over 97 per cent. If oleum is to be made, the gas will first pass through a tower over which oleum is recirculated. The concentration of the acid fed to the tower is maintained at 0.5 to 1.0 per cent less than the desired exit concentration. Such strong acids exert an appreciable vapor pressure of sulfur trioxide and, therefore, the absorption in such a tower will be incomplete. In order to insure recovery of the final traces of sulfur trioxide, a counter-current system must be used, and the absorption completed in a tower fed with acid of 97 to 99 per cent so that the residual vapor pressure of sulfur trioxide in the absorbing liquid will be negligible.

Acids more dilute than 97 per cent cannot be used because they exert an appreciable, though low, vapor pressure of water. In the presence of free sulfur trioxide even minute concentrations of water vapor condense to form a mist of sulfuric acid which is very difficult to recover. If sulfur trioxide gas is to be absorbed, there is an appreciable difference in vapor pressure between the gas and liquid phase which causes it to diffuse to the surface of the absorbing liquid. If, on the other hand, instead of gaseous sulfur trioxide, finely divided liquid sulfuric acid is to be recovered, there is no such potential difference tending to drive the particles to the surface of the absorbing liquid. The only way these particles may be removed is by causing them to settle or to impinge on a surface, but both of these are difficult in practice and mist formation must be avoided.

The absorption of sulfur trioxide is strongly exothermic. A large rise in temperature of the absorbing acid in any of the towers is undesirable; for in the oleum towers this means an increase in the vapor pressure of sulfur trioxide with a consequent decrease of capacity, and in the final towers it means an increase in the vapor pressure of water with a consequent tendency to mist formation. Coolers are therefore provided in the acid-circulating system of all towers.

References

- (1) FAIRLIE, A. M., "Sulfuric Acid Manufacture," Reinhold Publishing Company (1936).

- (2) MASON, *Ind. Eng. Chem.*, **30**: 740-746 (1938).
- (3) BUTTERWORTH and SCHWAB, *Ind. Eng. Chem.*, **30**: 746-751 (1938).
- (4) McIVER, CHATELAIN, and AXELRAD, *Ind. Eng. Chem.*, **30**: 752-758 (1938).
- (5) KIRKPATRICK, S., *Chem. Met. Eng.*, **45**: 483-487 (1938).
- (6) DINSMOOR, *Trans. Am. Inst. Chem. Eng.*, **26**: 158-165 (1931).
- (7) FREEMAN, *Chem. Met. Eng.*, **44**: 311-313 (1937).
- (8) WYLD, W., "The Manufacture of Sulfuric Acid (Chamber Process)," D. Van Nostrand Company (1924).
- (9) GILCHRIST, P. S., *Chem. Met. Eng.*, **26**: 1159-1162 (1922).
- (10) ZEISBERG, F. C., *Trans. Am. Inst. Chem. Eng.*, **14**: 1-11 (1921).
- (11) PARTINGTON, J. R., "The Alkali Industry," D. Van Nostrand Company (1925).
- (12) LEWIS, W. K., and RIES, E. D., *Ind. Eng. Chem.*, **17**: 593-598 (1925), **19**: 830-837 (1927).
- (13) THOMPSON, A. P., *Trans. Am. Inst. Chem. Eng.*, **27**: 264-319 (1931); also *Chem. Met. Eng.*, **38**: 705-709 (1931).

Problems

1. What is the composition of the gas obtained by burning pure FeS_2 with 50 per cent excess air, assuming that all the iron goes to Fe_2O_3 ?

2. A Glens Falls sulfur burner is operated on atmospheric air containing some moisture. The atmospheric pressure is 753 millimeters of Hg and the partial pressure of the water vapor is 13 millimeters of Hg. The gas leaving the primary chamber contains only N_2 , SO_2 , S_4 , and water vapor. The total pressure of this gas is 753 millimeters and the partial pressure of S_4 is 76 millimeters.

How much secondary air, expressed as mols per mol of primary air, must be added in the secondary combustion chamber to burn the sulfur and

a. Yield a gas containing the theoretical requirement for converting all SO_2 to SO_3 ?

b. Yield a gas containing 10.5 per cent SO_2 , dry basis?

c. Yield a gas containing 8 per cent SO_2 , dry basis?

3. Referring to Problem 2, how many mols of water vapor will be present in the gas leaving the secondary combustion chamber, per mol of SO_2 , in each of the three cases stated?

4. A sulfuric acid plant makes 100 tons of 60° acid per day. How many pans three by six feet will be needed to burn the sulfur? How many Glens Falls burners, of what size, would do the same work?

5. Specify the size of the Glover tower for the plant of Problem 4. If the inlet gas temperature is 1000°F., what will be the actual inlet gas velocity (calculated on the empty tower)?

6. Specify the total volume of the chambers and the size of the Gay-Lussac tower, for this plant, if the plant is designed for maximum output per cubic foot of chamber volume.

7. How much water must be supplied to the chambers?

8. Each of two plants makes 50 tons of 66° acid per day in a tower concentrator. One takes 60° acid from the Glover tower for concentration, the

other finds it necessary to send chamber acid to the concentrator at 53°Bé. What is the saving in water evaporated in the first plant?

9. Three brimstone burner gases, *A* containing 14 per cent SO₂, *B* containing 10.5 per cent SO₂, and *C* containing 8 per cent SO₂, balance in each case O₂ and N₂, are available. Calculate for each gas:

- a. Concentration of SO₃ at equilibrium at 450°C. and 1 atmosphere.
- b. The per cent conversion of SO₂ to SO₃ at equilibrium at 450°C. and 1 atmosphere.

10. A contact sulfuric acid plant in the tropics wishes to manufacture acid as strong as possible. The humidity is such that the partial pressure of water vapor in the air is 38 millimeters of Hg. This water is removed by scrubbing with strong acid; the dilute acid resulting must be included in the product (it is all used for dilution in the absorption system, and furnishes all of the water in the product). The burner gas contains 6 per cent SO₂ (dry basis). Assume 98 per cent conversion of SO₂ to SO₃ and 100 per cent conversion SO₃ to acid. Total pressure equals 760 mm.

- a. What is the strength of the product?
- b. What is the minimum percentage of SO₂ in the gas that will permit manufacture of 105 per cent equivalent H₂SO₄?

11. Predict the increase in efficiency which could be expected if the operating pressure of a contact sulfuric acid plant were increased from 1 to 8 atmospheres (absolute pressure). The burner gas contains 8 per cent SO₂, and the converters operate at an outlet temperature of 450°C. Assume equilibrium in exit gases.

12. A contact plant is to produce 10 tons of 20 per cent oleum and 40 tons of 98 per cent acid per day. The 98 per cent tower is fed with 97 per cent acid obtained by diluting part of its output. The oleum tower is fed with 19 per cent oleum obtained by diluting part of its output with 98 per cent acid obtained from the 98 per cent tower.

Calculate: (on a per day basis)

- a. Tons of 98 per cent acid going to oleum tower system.
- b. Tons of 19 per cent oleum entering oleum tower.
- c. Tons of 97 per cent acid entering 98 per cent tower.

13. A contact sulfuric acid converter uses the heat of reaction in the first stage for preheating the incoming gas. The heat of reaction (liberated) is

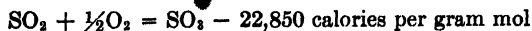

Sufficient conversion is obtained to preheat the gas from 400 to 460°C. The gas from the brimstone burner contains 8 per cent SO₂. If all of the heat liberated goes into pre-heat (*i.e.*, none is lost in radiation, and there is no change in temperature of the converted gas), what fraction of the SO₂ present is converted in this stage of the converter?

Specific heats (mean, between 400 and 590°C.)

Air: 0.25 B.t.u. per pound per degree Fahrenheit.

SO₂: 0.19 B.t.u. per pound per degree Fahrenheit.

CHAPTER IV

FIXED NITROGEN AND NITRIC ACID

Various forms of nitrogen compounds not only are needed in the chemical industry but are absolutely indispensable in agriculture as one of the principal constituents of fertilizer. Formerly, combined nitrogen was obtained entirely from manure and other animal and vegetable wastes, but modern civilizations have found it necessary to supplement, and almost replace, these materials from chemical sources. The search for, and manufacture of, these compounds has resulted in the fixed-nitrogen industry.

The first forms in which industry provided fixed nitrogen were ammonia from the manufacture of coke, and sodium nitrate, found as such in Chile and hence usually called *Chile saltpeter*. These two forms of fixed nitrogen are still in use.

At about the turn of the century, attempts were made to use the nitrogen in the air as a starting point for the manufacture of fixed nitrogen compounds.⁽¹⁾ This was first attempted by oxidizing the nitrogen of the air in the electric arc and collecting the resulting nitric oxide as nitric acid or nitrates. This process, though operated for some time on a large commercial scale, is now becoming obsolete.

It has long been known that calcium carbide would absorb gaseous nitrogen to form calcium cyanamide (CaCN_2), which could be in itself used as fertilizer or serve as the source of ammonia, cyanides, and other compounds of nitrogen. This process has never fulfilled the expectations of its founders, but does represent an important source of fixed nitrogen.

In 1913, the first full-sized commercial plant for the synthesis of ammonia from gaseous nitrogen and hydrogen was put into operation at Oppau in Germany. This process underwent tremendous development during the First World War and now represents the largest single source of combined nitrogen.

The world's production of fixed nitrogen from these various processes, based on a fiscal year ending June 30, is shown in Table XI for three representative years.

TABLE XI.—WORLD'S PRODUCTION OF FIXED NITROGEN
(Thousands of Metric Tons of Contained Nitrogen)

	1927-1928	1932-1933	1937-1938
Chile saltpeter.....	390	71	224
Cyanamide.....	198	168	305
Nitrate of lime.....	105	118	195
By-product ammonium sulfate.....	368	258	765
Other fixed nitrogen (largely synthetic NH ₃).....	663	1,062	1,391
Total.....	1,724	1,677	2,880

For the fertilizer year 1939-1940, the total fixed nitrogen production of the United States was about 400,000 metric tons of nitrogen; and the total consumption of fixed nitrogen in the United States was 580,000 metric tons.

The various processes for the oxidation of nitrogen in the electric arc were commercially successful on a large scale only in Norway, where exceptionally cheap power was available and no markets for it were at hand. This process required the expenditure of more power per ton of nitrogen fixed than any of the other processes that have been suggested. Another difficulty was the fact that the concentration of oxides of nitrogen in the gases was very low, and it was difficult to recover them as nitric acid. At the present time a large part of this capacity has been replaced by synthetic ammonia plants. The nitric acid made in these plants was largely converted to calcium nitrate for use as a fertilizer. However, the item "nitrate of lime" in Table XI represents not only nitrogen so fixed, but also calcium nitrate made from nitric acid obtained by the oxidation of synthetic ammonia.

SODIUM NITRATE

Deposits of sodium nitrate are found in a number of places, but the only important ones are in Chile. Parallel to the Pacific Ocean and a few miles back from the coast is a high, level, rainless plateau called the Atacama Desert. Scattered over this desert in an area from 3 to 30 miles wide and about 400 miles long are deposits of nitrate-bearing material known as *caliche*. These are not continuous but are massed in more or less separate districts. The *caliche* occurs in layers varying widely in thickness and

sodium nitrate content. It is usually a layer 2 to 6 feet thick, covered with a barren overburden 2 to 10 feet thick. A typical analysis is

	Percent		Per cent
NaNO ₃	17.6	CaSO ₄	5.5
KNO ₃	1.3	NaIO ₃	0.11
NaCl.....	16.1	Na ₂ B ₄ O ₇	0.94
Na ₂ SO ₄	6.5	KClO ₄	0.23
MgSO ₄	3.9	Insoluble.....	48 (approx.)

A number of theories have been advanced to account for the formation of these deposits, but none is free from criticism.⁽²⁾ The supposition that these deposits originated from beds of guano is open to the objection that phosphates, which are always associated with guano, are absent from these deposits. Likewise, that these deposits are of marine origin does not take into account the absence of bromides. The association of nitrates and borates gives some indication of volcanic origin. An explanation which is perhaps most free from criticism is that intense electrical storms in past ages formed in the air quantities of nitric oxide which were absorbed in rain water in the mountains. This acid rain water decomposed rock material over which it passed, and subsequent capillary action may have brought to the surface solutions containing nitrates and other dissolved salts, in the rainless area in which these deposits occur.

Recovery of Sodium Nitrate from Caliche.—The two principal soluble constituents of caliche are sodium nitrate and sodium chloride. The key to the separation is the fact that when a hot solution saturated with respect to both salts is cooled, the only salt separated is sodium nitrate, and the cold mother liquors are unsaturated with respect to sodium chloride. If these mother liquors are heated in the presence of caliche, they will dissolve only sodium nitrate. A similar system is the one used for the separation of sodium chloride and potassium chloride described in detail on page 209.

Originally the extraction process used was the *Shanks process*, which was usually rather crude in its equipment and inefficient in its utilization of heat. In recent years this has been largely replaced by the *Guggenheim process*.⁽³⁾

In this process the ore is first crushed and separated into fine material (passing a 30-mesh screen) and coarse material (about

$\frac{1}{2}$ inch). The fine material is mixed with mother liquor, filtered on a Moore filter and washed with weak liquor. The filtrate and wash water result in a solution of sodium nitrate returned to the main cycle.

The coarse ore is leached in large concrete tanks holding about 7,500 tons of ore each. These tanks are filled and emptied mechanically. Mother liquor is heated to about 40°C. and circulated through four such tanks in series in countercurrent (the strongest liquor is taken from the tank that has been just charged and the weakest liquor is fed to the tank that is most nearly exhausted). The warm strong liquor is passed through a series of tubular heat interchangers, which reduce its temperature to about 15°C., and is then cooled by ammonia refrigerating coils to 5°C. It then goes to a Dorr thickener which separates the crystals, and the cold liquor is returned through the series of heat interchangers to go back to the leaching system. Heat requirements of the process are supplied from the waste heat of the Diesel engine installation that supplies power for mining and for operation of the plant.

The slurry of fine crystals recovered from the bottom of the Dorr thickeners is centrifuged, dried, and briquetted. These briquets are melted in a direct-fired furnace and the fused sodium nitrate is pumped through spray nozzles to give a final product that consists of pellets of a uniform size. These are sacked for shipment.

The Chilean government imposes heavy taxes on the sodium nitrate industry, and these form an appreciable part of the cost of the material as delivered. The rapid growth of the ammonia synthesis process, with its production of cheap ammonia at points close to the consuming markets, has made serious inroads into the Chilean saltpeter industry. It seems quite definite that Chile saltpeter will play a smaller and smaller part in the fixed nitrogen industry in the future, except in abnormal times.

NITRIC ACID

Nitric acid, unlike most heavy chemical products, has a single large use, namely, the manufacture of explosives. If to explosives are added other similar nitrated products, over 90 per cent of the total production of nitric acid is thus accounted for. The amount

that goes into miscellaneous manufacturing processes is relatively small.

The nitric acid made in the United States in 1937 was equivalent to 154,000 tons of 100 per cent acid. Of this total, about 8 per cent was made from sodium nitrate and the balance from the oxidation of ammonia.

Nitric acid is usually marketed in the following grades:

Degrees Baumé	Specific gravity	Per cent HNO ₃
36.....	1.330	53.3
38.....	1.355	56.5
40.....	1.381	61.4
42.....	1.408	67.2

Nitric acid may be shipped only in glass carboys, which makes the cost prohibitive for transporting large quantities over even moderate distances. Nitric acid plants are therefore usually built in connection with the process where the acid is to be used. In many nitrating processes, however, a mixture of strong nitric and strong sulfuric acid is desired. If the mixture contains less than 20 per cent water, it does not attack ordinary steel plate, and consequently such mixed acid can be shipped in steel tank cars. Nitric acid free from sulfuric acid does not attack pure aluminum, but the resistance of apparatus made of ordinary commercial aluminum is uncertain.

Nitric Acid from Saltpeter.—Figure 21 is a flow sheet for the manufacture of nitric acid by the interaction of sodium nitrate and sulfuric acid.^(4,5) If a large yield of high strength nitric acid is desired, the sodium nitrate will be first dried in an ordinary rotary drier. The dried sodium nitrate and sulfuric acid are charged into a retort, still warm from a previous run. This retort is heated by direct fire. The nitric acid vapor, partly dissociated, is distilled into a condenser. The condensed acid goes to a cooler and is drawn off as either strong or weak acid, according to the stage of distillation. The weak acid usually contains lower oxides of nitrogen, and is passed through a bleacher, where these are removed by a current of air. The products of dissociation which pass the condenser go to a series of towers where they are absorbed in water. The result is to pro-

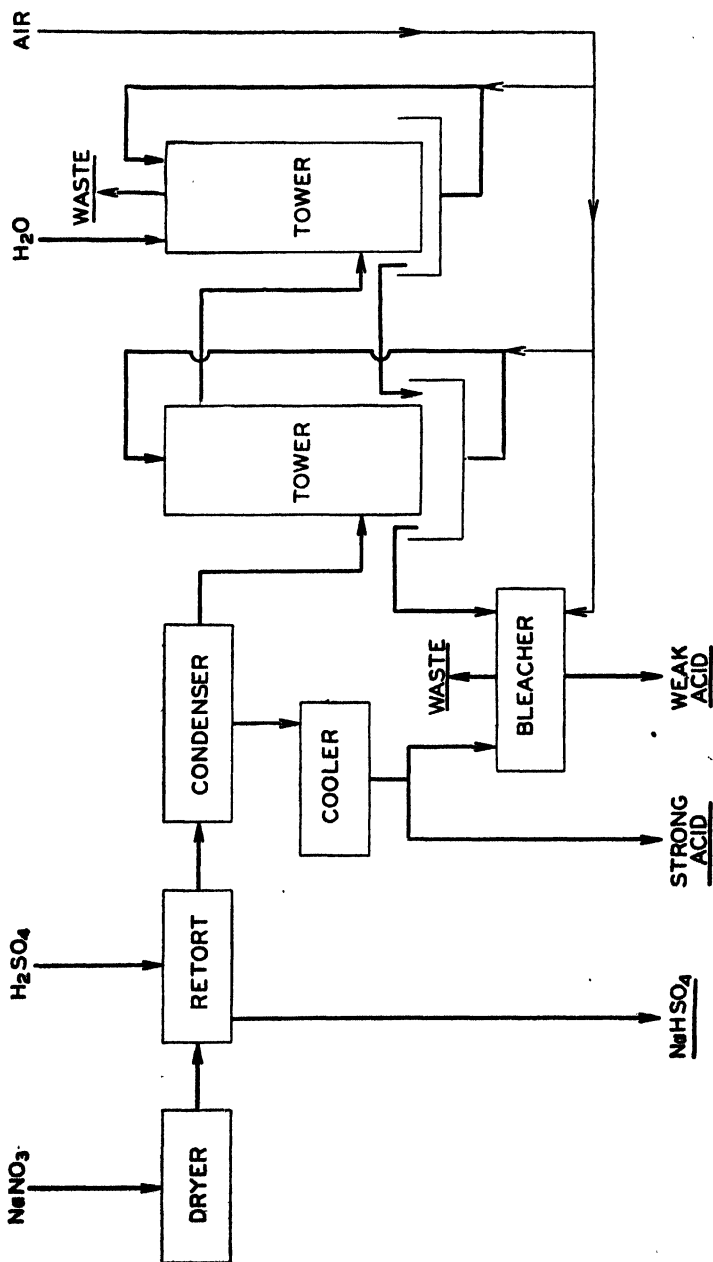

Fig. 21.—Flow sheet for manufacture of nitric acid from nitrate.

duce additional weak acid which is added to the weak acid from the condenser. At the end of the system of absorbing towers some device (usually a steam-jet exhauster) is employed to carry this part of the system under slight vacuum. The gaseous products leaving the absorbing towers are simply discharged into the air. The water in the absorbing towers is circulated over each tower a number of times, usually by air-jet lifts, and the air so introduced assists in the oxidation and recovery of the lower oxides of nitrogen.

Retorts.—The retort is a cast-iron vessel mounted in a brick setting. A typical arrangement is shown in Fig. 22. Different designs vary from a relatively flat dish to a retort almost pointed at the bottom. They will average 5 to 7 feet in diameter, and 6 to 8 feet high from the draw-off to the cover flange. They are supported by brackets resting on steel inserts in the upper part of the brickwork. It is essential that the bottom part of the pot and the draw-off pipe be free of the brickwork, so as to avoid stresses from expansion.

The grate may be relatively small, but must be set forward so that the bottom of the retort is not directly exposed to the flames. Baffles are built in the setting so that the gas passes around the pot in two or more passes before escaping to the stack. The setting should be continued above the level of the top of the retort so that the hot gas may pass over the cover, to prevent condensation of acid on its under side, with consequent rapid corrosion.

The reaction taking place in the retort is represented by the following equation:



This would call for 98 parts of 100 per cent sulfuric acid to 85 parts of 100 per cent sodium nitrate. The charge is proportioned, taking into account the strength of the acid and the purity of the sodium nitrate, to give slightly less than this amount of acid, or 1.05 to 1.10 parts of 66° acid to one part of 96 per cent nitrate. The residue left in the retort at the end of the charge, therefore, will be a mixture of NaHSO_4 and Na_2SO_4 , and need not be heated above 200°C. in order to be sufficiently fluid to flow readily from the retort. It is desirable to maintain as low a temperature as possible during the distillation because of the

ease with which nitric acid is decomposed by heat. Consequently, if it becomes necessary to force the apparatus to increase

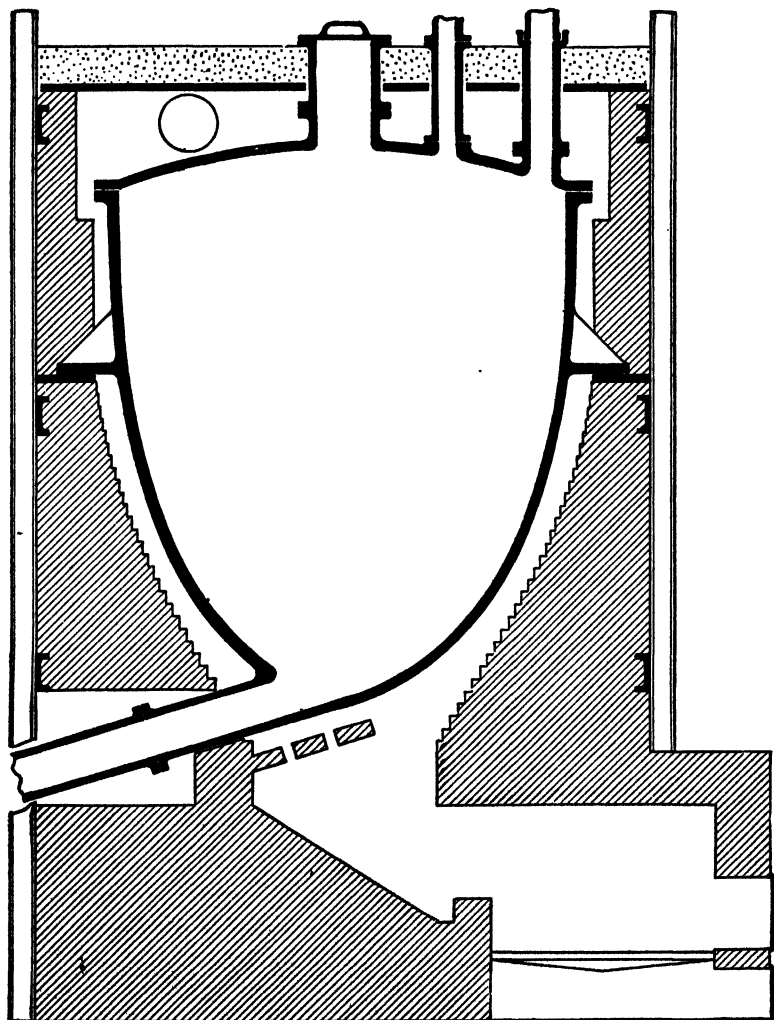

FIG. 22.—Nitric acid retort.

production, this should be done by increasing the proportion of sulfuric acid used, rather than by increasing the temperature.

The acid sodium sulfate withdrawn from the retort is known technically as *niter cake*, and because of its acidity is difficult to

handle. It may be run onto floors of acid-proof brick to solidify, or chilled on a flaking roll (see Fig. 50).

There is little preference between coal, oil, or gas for firing the retorts, but great care in the firing is necessary in any case. When the retort is first charged, firing should be begun promptly, and the temperature of the pot should be increased steadily with gradual increase in the rate of distillation until the reaction becomes fairly rapid. The reaction is slightly exothermic, and during the next 2 or 3 hours comparatively little heat is required. Should the reaction begin to slow down, it is essential that more heat be applied and the temperature gradually raised until the

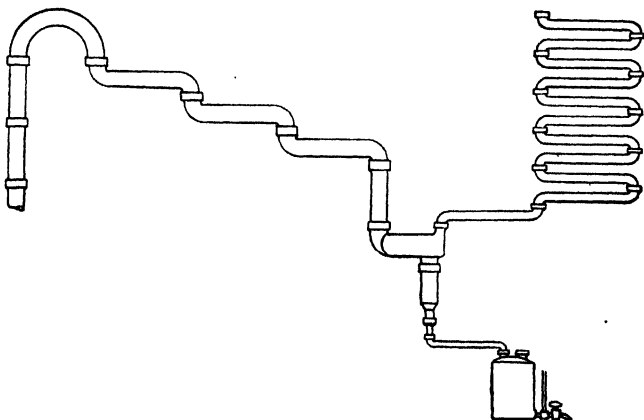

FIG. 23.—Condensing system for nitric-acid vapors.

distillation is substantially complete. The fire is then drawn and the pot emptied. A typical charge is distilled in about 12 hours. The concentration rises to about 99 per cent HNO_3 at the end of the first hour, and then drops off slowly, falling to 90 per cent after 10 hours and ending at about 85 per cent.

Condensing System.—Figure 23 shows an apparatus for cooling and condensing nitric acid vapor. The system illustrated consists of fused quartz, although similar systems are made of acid-proof irons, such as Duriron. The gas first passes through a series of air-cooled S-bends, which discharge vapor and some condensed acid into a collecting pot. From this pot risers connect to two or more stacks of S-bends that are cooled by showering water over them. In some designs, the collecting pot is so arranged that the vapor passing to the water-cooled stacks bub-

bles through the acid. From the collecting pot the acid passes through two or three water-cooled pipes to a closed receiver. In this condensing system the flow of the acid is countercurrent to that of the gas. This aids in displacing oxides of nitrogen from the acid and sweeping them towards the gas exit. The apparatus is so designed and operated that vapor and liquid are brought into intimate countercurrent contact; and if the acid leaving the collecting pot is not too cool, a water-white acid may be produced.

Recovery of Nitrogen Oxides.—The vapor from the nitric-acid pot during distillation consists not merely of nitric acid and water, but also contains dissociation products of nitric acid. Table XII shows the dissociation of nitric acid at various temperatures and at 1 atmosphere total pressure.

TABLE XII.—DECOMPOSITION OF NITRIC ACID

Temperature, Degrees Centigrade	Per Cent Dissociated
86	9.53
100	11.77
130	18.79
160	28.96
190	49.34
220	72.07
250	93.03
256	100.00

Inasmuch as the temperature of the nitric-acid vapor, measured in the gas uptake, varies from 110 to 130°C. during most of the run, it is apparent that from 10 to 20 per cent of the nitric acid passes from the still in the form of oxides of nitrogen, oxygen, and water vapor. As the temperature of the vapor is lowered in the condenser, much of these dissociation products will recombine, yielding nitric acid. In order, however, to obtain complete recombination, it is necessary to provide an excess of both oxygen and water, and a much longer time for the reaction than is afforded in the condenser. This recombination takes place in the absorption or recovery towers. The recovery of nitric acid from oxides of nitrogen will be described in connection with the manufacture of nitric acid from ammonia.

AMMONIA

An inspection of Table XI will show that the production of natural and synthetic ammonia is the largest factor in the world

production of fixed nitrogen. This is particularly true in the United States, where about 91 per cent of all the nitrogen fixed is produced in the form of ammonia.

Production and Consumption of Ammonia.—The production of fixed nitrogen in the United States in 1939 was approximately 500,000 short tons. This was obtained from the following sources.

TABLE XIII.—PRODUCTION OF FIXED NITROGEN IN THE UNITED STATES IN 1939

	Per cent
Organic nitrogen.....	9.3
By-product ammonia.....	35.3
Synthetic ammonia.....	55.4

The consumption of ammonia in 1939 was as follows:

TABLE XIV.—DISTRIBUTION OF AMMONIA IN 1939

	Per cent
Fertilizers.....	51.8
Heavy chemicals.....	19.6
Explosives.....	8.9
Dyes and organic.....	1.5
Miscellaneous.....	18.2

By-product ammonia comes entirely from the destructive distillation of coal and other organic materials and, therefore, is properly discussed in connection with organic technology.

Synthesis of Ammonia.—In the earlier literature of the subject, a considerable variety of processes were recognized, such as the Haber, the Claude, and others. At the present time, these are looked on, not as separate processes, but as variants of a general method. There are variations in temperature and pressure employed, in type of catalyst, in preparation of the raw materials; but all the processes may be understood by referring to the flow sheet of Fig. 24. This is a more or less idealized flow sheet for a plant using by-product hydrogen as a raw material.

Hydrogen and air are pumped in measured amounts to a burner where the oxygen of the air is burned with the hydrogen, and the mixture so adjusted that the products of combustion will contain as nearly as possible three volumes of hydrogen to one volume of nitrogen. This mixture is cooled and scrubbed with a dilute solution of sodium hydroxide to remove carbon dioxide and is then compressed to the working pressure. This

pressure may vary considerably in different plants, but in the United States is usually about 5,000 pounds per square inch. The compressed gas is cooled; and any water and oil that have condensed are collected in a trap and removed. The gas is then passed over activated-carbon filters to remove last traces of oil.

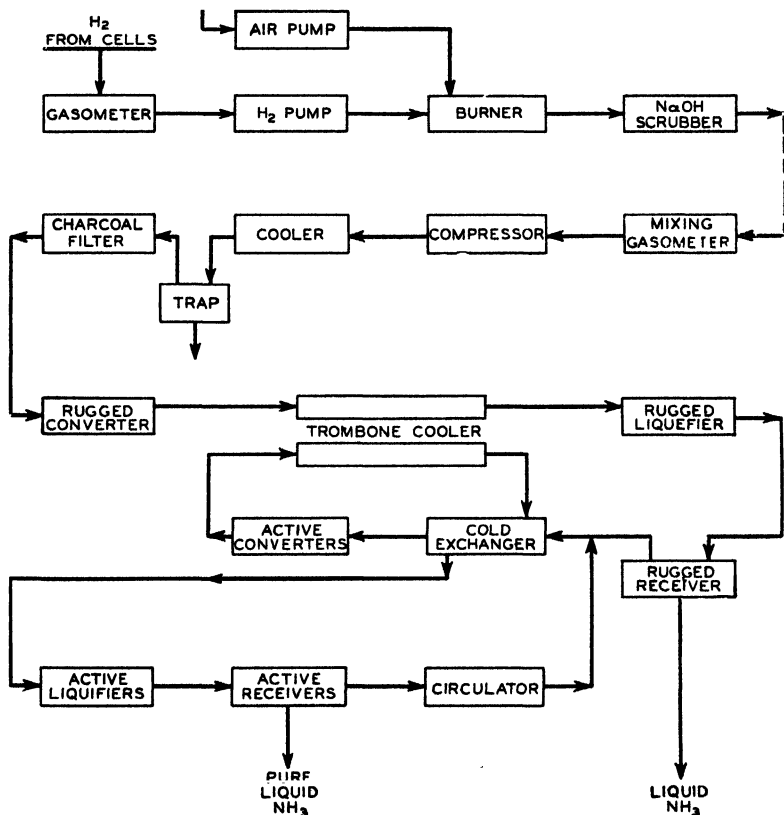

FIG. 24.—Flow sheet of ammonia-synthesis process.

The next step in the process is the final purification of the gas, and this differs quite widely in different plants. In the particular plant shown in Fig. 24, a catalyst chamber containing a very rugged and not very active catalyst is used to convert a small part of the gaseous mixture to ammonia. The gas is cooled by water, then by passing through a refrigerated condenser, and some liquid ammonia is separated and collected in a receiver.

This ammonia contains in solution the final traces of water and carbon dioxide. It is not sold as high-grade liquid ammonia, but is used to make aqua ammonia.

The gas next passes through a cold interchanger where it is heated somewhat, then through a heat interchanger in the upper part of the catalyst bomb itself, and then to the active catalyst. Here the principal synthesis of ammonia takes place. The converted gas passes back through the heat interchanger in the catalyst bomb, through a water cooler, through the cold interchanger mentioned above, and finally through a refrigerated condenser. The ammonia liquefied in this condenser is collected in a receiver, and is withdrawn as the principal product.

The residual gas, which contains appreciable quantities of uncondensed ammonia, is returned to the cycle just ahead of the cold interchanger. In the various heat interchangers and the catalyst bed there is a pressure drop of about 200 pounds per square inch, so the pressure of this exit gas must be raised through this amount by a compressor called the circulator. There must be an oil trap after the circulator, and at this point inert gas (principally argon) which accumulates in the system is vented.

Theory of Ammonia Synthesis.—The basic reaction involved is merely



This reaction is exothermic and, therefore, equilibrium is reached with lower ammonia concentrations at higher temperatures. The synthesis results in a considerable decrease in volume, and therefore is favored by an increase in pressure. For the most favorable equilibrium, high pressures and low temperatures are indicated. The reaction velocity is very low, and some catalyst must be used to make the conversion commercially practicable. A wide range of combinations of pressure, temperature, and catalyst is possible; and the various processes that have been suggested differ principally in their choice of conditions.

Figure 25 shows the percentage of ammonia in the gas at equilibrium as calculated by Tour⁽⁶⁾ from Haber's data. Curve 1 shows the effect of temperature when pressure is held constant at 100 atmospheres, and curve 2 shows the effect of pressure when temperature is held constant at 500°C. Both of these are for a stoichiometric mixture of nitrogen and hydrogen. Curve

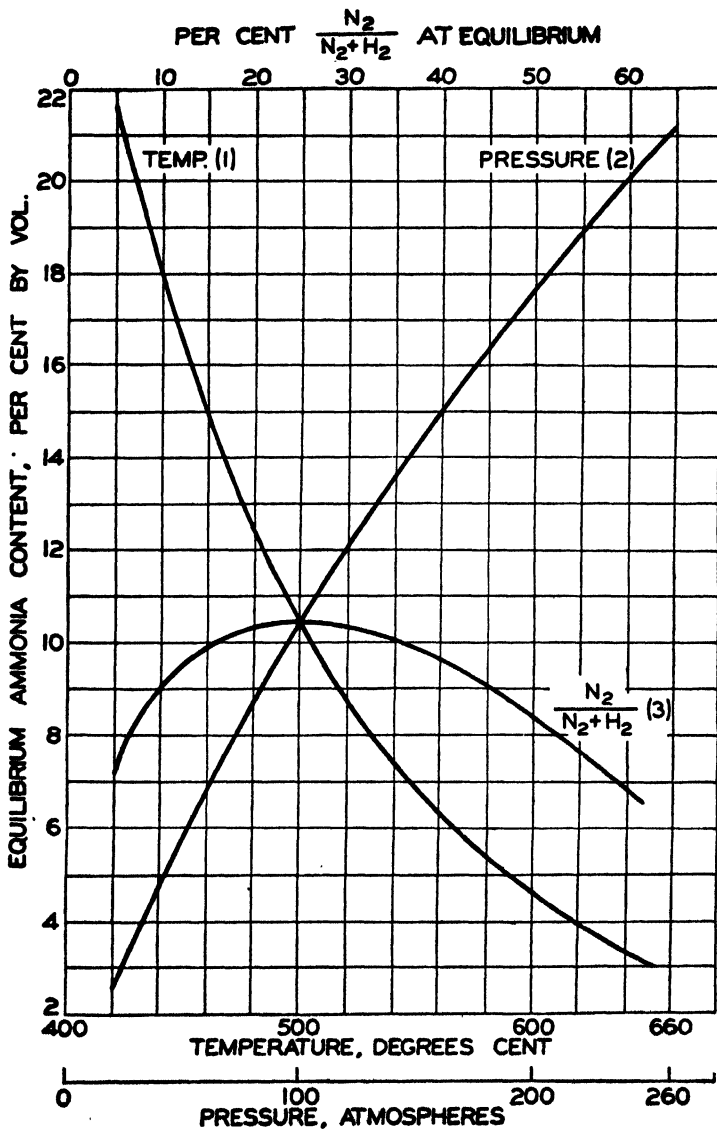

FIG. 25.—Equilibrium between nitrogen, hydrogen, and ammonia.

3 shows the effect of changes in composition when temperature and pressure are both constant at the above values. It will be noted that the concentration of ammonia at equilibrium increases very rapidly as the temperature is lowered and as the pressure is raised. It is evident that the best equilibrium for any one set of conditions is obtained with the theoretical ratio of nitrogen to hydrogen as shown in equation (13).

Catalysts.—In all the processes now operating, the raw catalyst charged into the bomb consists of Fe_3O_4 , together with small amounts of alkali or other metallic oxides. The catalyst is reduced to metallic iron by the hydrogen in the system during a preliminary operation at low temperatures. A large number of oxides have been suggested as activators or promoters⁽¹⁾ but, apparently, the common catalyst in use in the United States carries about 0.5 per cent K_2O and 2.5 per cent Al_2O_3 , balance Fe_3O_4 . There is considerable published work on the effect of conditions on the activity of a large number of catalysts.⁽⁷⁾ These catalysts are sensitive to certain poisons; particularly oxygen in any form, such as carbon monoxide, carbon dioxide, and water. The presence of these impurities in the gas does not permanently destroy the activity of the catalyst but merely results in a greatly decreased conversion while they are present. Such poisons, however, are sufficiently eliminated by the various purification methods in common use.

Entirely aside from the effect of temperature on equilibrium, too high a temperature can destroy the activity of a catalyst. It is, therefore, necessary to watch the temperatures in the catalyst chamber very carefully to prevent such destructive temperatures being reached. In the course of time, an active catalyst gradually decreases in activity. This results first in the necessity of gradually increasing the temperature or the gas velocity or both; and finally the catalyst must be replaced. With careful operation the time between replacements may be a matter of years. Where a rugged converter is used as a gas purifier (as in Fig. 24), the rugged catalyst is a charge of discarded active catalyst.

In the synthesis of sulfur trioxide by the contact process, the equilibrium is so favorable and the velocity of the reaction is so high, that the temperature and the amount of catalyst used may be fixed to give practically complete conversion. In

ammonia synthesis, on the other hand, even with the best practicable combination of catalyst, temperature, and pressure, only partial conversion could be attained at equilibrium. For the high pressures used in this process, the size of the catalyst vessel is decidedly limited. This means that gas velocities* must be high in order to obtain a satisfactory throughput. If the gas velocity be made extremely low, the concentration of ammonia in the exit gas may be nearly that corresponding to equilibrium, but the amount of gas handled will be so small that the actual yield in pounds will be negligible. As the gas velocity is raised, the concentration of ammonia decreases, but not as rapidly as the gas velocity increases. The net result is, therefore, an increased yield of ammonia. The increased gas velocity involves larger heat interchangers, smaller temperature drops in the heat interchangers, and an increase in the power for circulation and refrigeration. There is, therefore, some intermediate velocity where these two factors balance each other to give a minimum cost per pound of ammonia. The choice of this velocity, however, is further complicated by the fact that it is general practice to produce the temperature necessary for the reaction by conserving the heat of the reaction itself. Either too high velocities with low conversion, or high conversion but very low velocities do not produce sufficient heat to offset the unavoidable thermal losses. Since it is impossible to predetermine these effects quantitatively, the optimum velocity must be determined by experiment for each catalyst.

Preparation of Nitrogen and Hydrogen.—The flow sheet of Fig. 24 assumes that by-product hydrogen is available. In practice this comes principally from electrolytic caustic plants. Such a method of preparing the gas mixture is relatively simple and needs little comment. In some plants the caustic scrubbers for the removal of carbon dioxide are employed before the burners rather than after them.

Although 5 of the 10 synthetic ammonia plants in the United States operate on by-product hydrogen, 94 per cent of the total synthetic ammonia produced in the United States comes from plants that prepare the nitrogen-hydrogen mixture from producer gas and water gas. Figure 26 is a flow sheet of this process.^(8,9)

* Such velocities are usually expressed as space velocity: cubic feet of gas at standard conditions, per cubic foot of catalyst (bulk volume) per hour.

Carbon monoxide and nitrogen from a gas producer are mixed with carbon monoxide and hydrogen from a water-gas set, in such proportions that the sum of the carbon monoxide and hydrogen is slightly more than three times the nitrogen. This gas is passed through heat interchangers, is enriched with steam, and

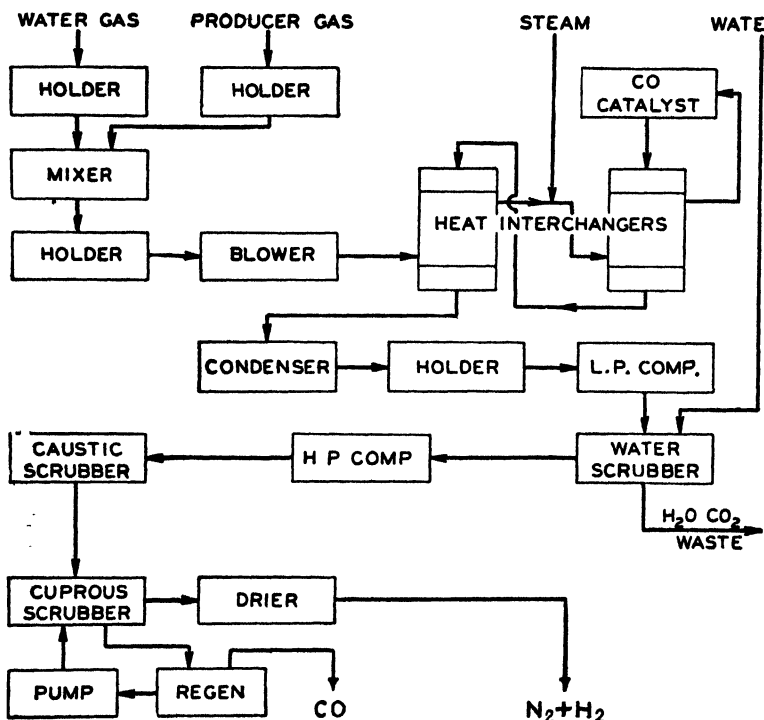
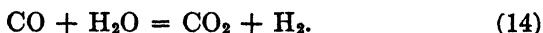

FIG. 26.—Flow sheet for preparation of nitrogen-hydrogen mixture for ammonia synthesis.

then sent through a vessel containing a catalyst which assists the reaction



In this step, most of the carbon monoxide is converted to carbon dioxide, liberating an equal volume of hydrogen. The gas is returned through the heat interchangers and a condenser, which remove excess steam that has not been decomposed. The gas is next compressed to about 25 atmospheres, and scrubbed with water to dissolve a large part of the carbon dioxide. This

water is discharged from the towers through a Pelton water wheel. The gas is next compressed to the operating pressure maintained in the rest of the system. The residual carbon dioxide is then removed by scrubbing with caustic soda and the unconverted carbon monoxide is removed by an ammoniacal solution of a copper salt. In some plants this completes the purification; in others the final purification may be the same as shown in Fig. 24.

The catalyst used for the oxidation of carbon monoxide to carbon dioxide consists of iron oxide with chromium oxide as a promoter. It is carried on trays in the converter shell, and the gas is passed over it at a temperature of about 500°. The reaction,

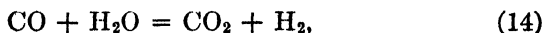

is slightly exothermic. Consequently, as the temperature is increased, larger amounts of carbon monoxide will remain unconverted at equilibrium but the reaction velocity will be increased. A temperature of 500°C. has been found to be the optimum. With from 3 to 5 volumes of steam per volume of carbon monoxide, the gas would contain about 1 per cent of carbon monoxide at equilibrium. Due to a lack of attainment of equilibrium, this is actually from 2 to 4 per cent. If the heat evolved by the reaction is not sufficient to maintain the converter bed at the desired temperature, some air may be introduced at this point, and the resulting combustion of hydrogen furnishes the necessary heat, although heat so supplied is relatively expensive. After passing the converter, the gas goes back through the heat interchangers and is finally cooled sufficiently to condense most of the steam. The compositions of these gases before and after converting are given in Table XV.

The next step is to remove most of the carbon dioxide by scrubbing under pressure with water. If the gas contains 30 per cent carbon dioxide, compression to 25 atmospheres gives an initial partial pressure of carbon dioxide of 7.5 atmospheres. This correspondingly increases the solubility in water, reduces the amount of water required, and makes it possible to reduce the carbon dioxide content of the scrubbed gas to 1 per cent or less. The scrubbing takes place in countercurrent in packed towers. This will obviously saturate the water with nitrogen and hydrogen also, at their respective partial pressures. The

work that was done in supplying the water to the towers under pressure is partly recovered in Pelton water wheels, but their efficiency is low due to the spraying of the water jets by the release of the dissolved gas. This gas is usually wasted.

The removal of carbon dioxide decreases the total gas volume, and consequently increases the concentration of the remaining impurities. Both carbon monoxide and carbon dioxide affect the catalysts unfavorably and must be removed as completely

TABLE XV.—COMPOSITION OF GASES IN THE SYNTHETIC AMMONIA PROCESS

	Water gas, percentage	Producer gas, per- centage	Mixed gas, percentage	Converted gas (dry), percentage
CO ₂	5 to 3	5	3 to 5	29 to 27
CO.....	42 to 45	25	39 to 36	2 to 4
H ₂	51 to 50	5	34 to 36	52
N ₂	2	63	23 to 22	17
X-CH ₄	2	1	0.4 to 0.8

	After water scrub, percentage	Dissolved gas after pressure release, percentage	After copper- ammonia scrub and adjusting, percentage
CO ₂	0.1 to 1.0	76 to 84	0
CO.....	3 to 5	0.1 to 0.01
H ₂	73 to 72	17 to 11	} 3 to 1
N ₂	24 to 23	6 to 4	
X-CH ₄	0.5 to 1.0	1	1.0 to 5.0
NH ₃	0.2 to 0.01
H ₂ O.....	0.02

as possible. This is done by scrubbing first with caustic soda and then with an ammoniacal solution of cuprous formate or cuprous carbonate. Since it is desirable to make this purification as complete as possible, the gas, before scrubbing, is compressed to the pressure at which synthesis will take place. The cuprous solution withdrawn from the towers is usually heated to remove the dissolved carbon monoxide and treated with metallic copper to insure that the copper in the solution is in the cuprous state. The dissolved gas is best removed by heating under vacuum, since in this way a lower temperature will suffice, and there is

less loss of ammonia and less oxidation of the copper. At one time, attempts were made to remove carbon monoxide with a strong, hot solution of sodium hydroxide, but the difficulties in holding this solution at the high temperatures and pressures involved proved too great and the method has been abandoned.

Catalyst Bombs.—At the temperatures at which these bombs must work, the elastic limit of even the best alloy steel is greatly reduced. At these pressures and temperatures, hydrogen diffuses through steel and combines with the carbon in it to form methane, which, in turn, causes blisters and cracks. At these temperatures ammonia also attacks steel, rapidly forming nitrides and breaking down the crystal structure. In modern construction these difficulties are largely solved by causing the incoming (and relatively cool) gas to flow along the inside wall of the bomb before entering the heat exchangers. This causes the outer bomb wall to be relatively cool and simplifies design.

A catalyst bomb, such as is used in the American process, is shown in Fig. 27.⁽¹⁾ The bomb (1) is made from a single forging of low-carbon chrome-vanadium steel, which may be from 8 to 40 feet long and from 16 inches to 3 feet in external diameter. The gas enters at the center of the bottom and flows upward between the main wall of the forging and a liner (2). At the top of the liner are openings (3) through which the gas passes, and then flows over the outside of the heat exchanger tubes (4). It then flows through openings (5) into a central cylinder (6) in which is located an electric heating coil (7) for adjusting the final temperature of the gas. From the bottom of this cylinder it passes up through the catalyst bed, which is contained in the annular space between the liner and the central tube. In small bombs the gas may pass through the catalyst only once. In larger bombs there may be baffles to cause the gas to make several passes (8, 9, 10) up and down through the catalyst as shown in Fig. 27.^(4, 5, 6)

After passing through the catalyst bed, the gas passes through connections (11) to the inside of the tubes of the heat exchanger (4). From the top of this heat exchanger it is collected in a header (12) and finally taken out of the bomb through the top at the center (13).

Figure 27 also shows a method for closing high-pressure vessels. The forged cap (14) sits on a metallic gasket (15) and carries all

the connections into and out of the bomb, including pyrometers (16). After the cap is in place, the ring (17) (usually provided with an interrupted thread) is dropped and screwed into place. The screws (18) are then used to force the cap into its seat.

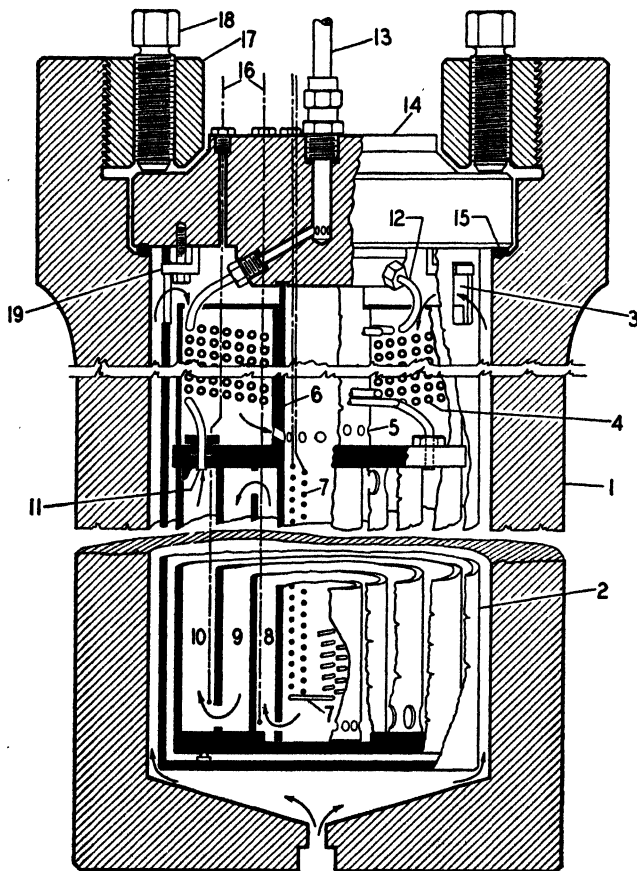

FIG. 27.—Catalyst bomb for ammonia synthesis.

The type of catalyst bomb used in the German plant at Oppau has been described by Tour.⁽⁸⁾

Ammonia Recovery.—Ammonia may be recovered either by dissolving in water or by liquefying by refrigeration. Refrigeration has the advantage of direct production of anhydrous liquid ammonia. The temperature to which the gas must be cooled depends on the pressure used and the conversion obtained. It

may be from -10 to -20°C . The small concentration of ammonia in the gas after refrigeration is not objectionable under the operating conditions now commonly used.

The water scrubbing process is simpler to carry out, but its great disadvantage is that it leaves the gas saturated with water vapor and, as already pointed out, this seriously decreases the activity of the catalyst. Further, this complicates the production of anhydrous ammonia, the form in which most ammonia reaches the market.

The ammonia collected in the receivers is drawn into tarred cylinders or into tank cars for direct shipment. It will, of course, be saturated with nitrogen, hydrogen, and argon, but these are removed by blowing off a small amount of ammonia from the liquid. This ammonia is recovered as aqua ammonia.

Modifications.—The original ammonia synthesis process worked out in Germany is commonly known as the *Haber* or *Haber-Bosch*.⁽¹⁾ It operates at about 200 atmospheres, a catalyst temperature of 500 to 600°C., and produces an exit gas containing 5 to 10 per cent of ammonia. It is represented in Germany by the largest single plants in the world, and the total installed capacity in Haber-Bosch plants through the world is approximately one-third of the world's capacity for ammonia synthesis.⁽¹⁰⁾

The *Claude* process is distinguished by the fact that it works at pressures from 900 to 1,000 atmospheres. The catalyst temperatures are approximately the same as in the Haber-Bosch, but at the higher pressure the gas leaving the catalyst contains about 25 per cent of ammonia. The very high pressures employed make the volume of gas small. The plant is extremely compact, and the heat liberation per unit volume of gas is great. Consequently, elaborate systems of heat interchangers are not required, and the conversion is so high that the gas does not need to be recirculated. In a Claude plant the gas merely passes through a series of catalyst chambers of extremely simple construction, each one followed by a condenser and receiver. From the last condenser the remaining gas (mainly argon) is discarded after passing through a scrubbing tower to recover its residual ammonia. The Claude process represents about one-tenth of the world's installed capacity for ammonia synthesis.

The *Casale* process is intermediate between the Haber-Bosch and the Claude. It works at pressures of from 500 to 900 atmospheres and at temperatures of about 500°C. It produces a gas containing about 15 per cent NH₃, but is principally characterized by the details of its converter construction. One-sixth of the world's installed capacity is in Casale plants, the largest of which are in France and Japan.

The *Fausser* process is characterized mainly by the use of the Fausser electrolytic cell for the production of hydrogen. It represents about one-tenth of the world's installed capacity.

The Fixed Nitrogen Research Laboratory in Washington has worked out a modified Haber-Bosch process, which is primarily characterized by the use of a rugged catalyst for purifying the gases as described in Fig. 24. This is sometimes called the *American* process. The *Nitrogen Engineering Corporation* has built plants using a modified Haber-Bosch process, sometimes employing the rugged catalyst for purification, and such plants amount to one-twelfth of the world's installed capacity. The American or Nitrogen Engineering Corporation plants usually operate at pressures in the neighborhood of 300 atmospheres and temperatures from 450 to 550°C. They produce gas containing from 12 to 18 per cent NH₃.

NITRIC ACID BY AMMONIA OXIDATION

With the proper catalyst a mixture of ammonia and air can be made to combine according to the reaction

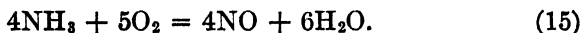

The process for nitric acid manufacture by this reaction is rather simple, as it consists merely in preheating the air, mixing it with ammonia, passing it over a platinum catalyst, extracting the heat from this mixture in the heat interchanger which preheats the incoming air, adding secondary air, and then absorbing the nitric oxide in water to form nitric acid^(11,12,13). This process has been developed to such a degree that it is now the most important process in the United States for the manufacture of nitric acid. As pointed out on page 80, it is making over 90 per cent of all nitric acid made in this country.

Equilibrium in Ammonia Oxidation.—The constant for the equilibrium in equation (15) is given by the expression:

$$\log_{10} K = \frac{216,000}{4.58T} + 1.75 \log T + 8.4 \quad (16)$$

At any temperature up to 1500°C., equilibrium would be reached at conversions of 99 per cent or over. Consequently the effect of temperature and pressure on equilibrium, which is so vital in many processes, is of minor importance here. The process can be carried out at temperatures high enough so that reaction velocities are satisfactory. The temperature (1000°C.) is higher, and the time of contact (0.0001 second) is shorter, than for any other known case of contact catalysis.⁽¹³⁾

In the presence of many materials, particularly iron, it is possible to have ammonia decomposing according to the reaction

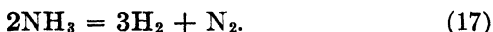

This hydrogen would be oxidized to water, so that the sum of the two reactions gives

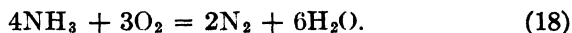

If unconverted ammonia passes the catalyst, it may react with the products of oxidation according to the equation



With properly designed equipment these reactions should not take place to an appreciable extent. In commercial practice, actual yields corresponding to 85 to 95 per cent of the theoretical are obtained.

Preparation of Gas Mixture.—Any source of ammonia may be used, but ammonia free from pyridine or compounds of phosphorus is especially desirable. Consequently, ammonia recovered from coal-tar distillation or cyanamid is less desirable than synthetic ammonia for this process.

The main reaction and the oxidation to nitrogen are both strongly exothermic. Nevertheless, the gas must be at 200 or 300°C. just before it comes in contact with the catalyst. It is not desirable to preheat the mixture of gases, since at these temperatures most metals catalyze the decomposition of ammonia into nitrogen and hydrogen. It is usual, therefore, to preheat the air only, and mix it with ammonia just before entering the catalyst chamber. This procedure is satisfactory because some excess air is used, so that the ammonia is only 10 per cent of the

total gases entering the converter. The parts of the system through which the gas passes after adding the ammonia should be made of aluminum, nickel, or quartz in order to avoid decomposition of ammonia.

Converter Construction.—A form of catalyst chamber developed by Jones and Parsons^(1,11) is shown in Fig. 28. The gas mixture

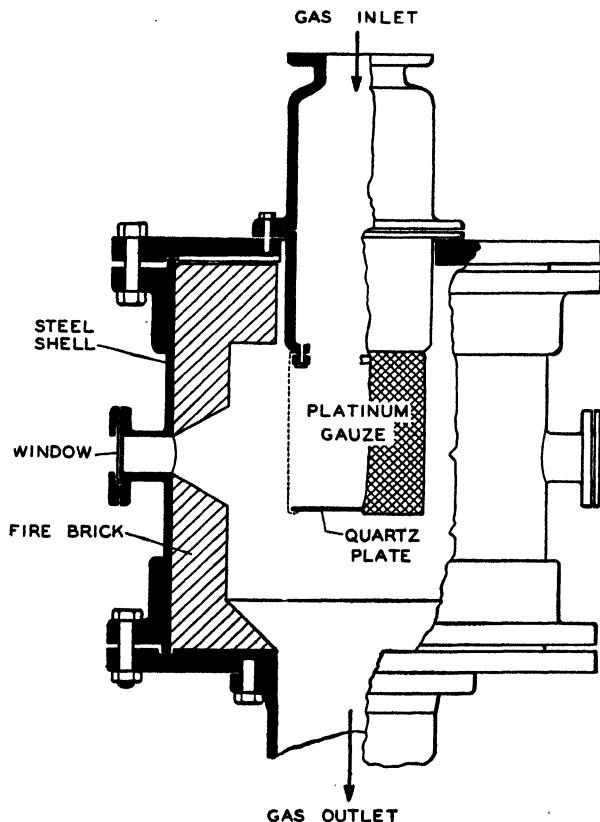

FIG. 28.—Catalyst chamber for ammonia oxidation.

enters an aluminum fitting at the top of the apparatus and passes downward through a nickel sleeve and through the catalyst, which consists of a cylinder of three or four layers of platinum or platinum-rhodium gauze, closed at the bottom by a quartz plate. This gauze cylinder is enclosed in a chamber of refractory material so that the heat which is liberated by the reaction may

be radiated to the catalyst. This maintains the gauze at a uniform temperature. Due to the heat of reaction, the temperature of the catalyst itself will be considerably higher than that of the incoming gases (possibly 1000°) and the exit gases are always above 600°C.

The catalyst gauze is in the form of a very fine mesh screen of 80 to 150 mesh and with wires from 0.001 to 0.003 inch in diameter. The gauze gains in efficiency on continued use due, apparently, to the development of a roughened surface of the metal which increases its area of contact with the gas. Experiments have been made with a catalyst consisting of a single layer of gauze but the time of contact with the gas was too short and multiple-gauze catalysts are now universally used. A plant using such a catalyst will oxidize 70 pounds of ammonia per day per troy ounce of platinum in the gauze. The sprouts that form on the surface of the platinum gradually dust off, so that there is an actual loss of platinum of about 7 per cent per year. With a properly operated catalyst of the above construction it is possible to run continuously with conversion efficiencies of 95 per cent.

Recovery System.—The gas leaving the catalyst passes through the heat interchanger that is used to preheat the air. The heat of reaction is sufficient to cover all heat losses so that after the process is in regular operation no external supply of heat is needed. After leaving the heat interchanger more air is added to supply oxygen for oxidizing NO to nitric acid.

In the presence of oxygen, nitric oxide is oxidized according to the reaction



This reaction proceeds very slowly,⁽¹⁾ and even at equilibrium is incomplete. A mixture of NO and NO₂ may combine, giving small amounts of N₂O₃. It has been definitely shown, however, that in the gaseous phase at ordinary temperatures only a small concentration of N₂O₃ can exist. NO₂ reacts with water rather rapidly according to the following reaction:

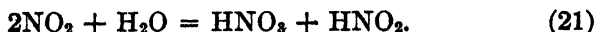

The nitrous acid so formed reacts with further NO₂ as follows:

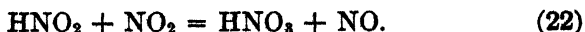

This reaction also takes place rapidly and is accompanied by a slower one as follows:



If equations (21) and (22) are added, they are equivalent to the following:

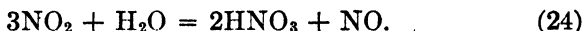

In other words, when NO is oxidized to NO₂ and then reacts with water, approximately two-thirds of the NO₂ is absorbed to form nitric acid, and one-third is reduced to NO, which must again be oxidized. Since the concentration of this NO is lower than at the time of the original oxidation, the second oxidation goes more slowly, in any practical apparatus will come less near to equilibrium, will release still smaller quantities of NO, and thus the process becomes slower and slower until the final concentration of NO is so low and its rate of oxidation so slow that further recovery as nitric acid is impracticable.

Construction of Absorption Towers.—The construction of the absorption system varies according to the size of the plant. In very small plants these towers may be built of acid-proof stoneware. In the larger plants they are built of chrome iron. They may range from 30 inches in diameter by 15 feet high, up to 10 feet in diameter and 50 feet high. They are arranged so that water is introduced into the next to the last, or second from the last, tower of the series, and is gradually advanced to the tower making the strongest acid. Relatively large amounts of liquid are circulated in each tower compared to the amount of fresh water fed, so that the composition of the absorption liquid in each tower is reasonably uniform. There may be from 3 to 10 towers in series according to the completeness of recovery and the concentration of acid desired. In a large plant it is usually more economical to feed the last tower, or the last two towers, with sodium hydroxide solution, thus recovering the residual oxides of nitrogen as sodium nitrite and sodium nitrate.

Because of the slowness of the reaction in the gas phase, the packing in the absorption towers should be so chosen as to give the maximum percentage of free volume in order to give space, and therefore time, for the oxidation of NO to NO₂. The wetted surface of the packing per cubic foot is of less importance because

of the rapidity of the reaction between NO_2 and water. The gas velocity is normally about 0.8 to 1.0 foot per second, and the time in the series of towers is 5 to 7 minutes.

In an ordinary system 60 per cent acid is the most concentrated that can be made, and it is much easier to make 45 to 50 per cent acid. The ordinary absorption system recovers 85 to 90 per cent of the theoretical yield of nitric acid.

Pressure System.—The oxidation of ammonia and the absorption of the resulting oxides of nitrogen to form nitric acid has usually been carried out at atmospheric pressure. The same process has also been carried out under a pressure of approximately 100 pounds per square inch.⁽¹⁴⁾

An examination of equation (15) shows that there is a slight increase in volume as the reaction goes to the right. This shows that the oxidation of ammonia under pressure is disadvantageous to the equilibrium. In practice, this effect is not too great and has been offset by improvements in the catalyst, notably by use of an alloy containing 5 per cent of rhodium instead of a pure platinum catalyst. Reactions (20), (21) and (24) show a decrease in volume as the reactions go to the right. Consequently, these equations should be favored by an increase in pressure, and actually this is where the great advantage of the pressure process is found. It would seem desirable to carry out the oxidation of the ammonia at atmospheric pressure and then compress the gases before absorption. This has not proved practical because of the difficulties met in attempting to design a compressor to handle these acid gases.

Reaction (24) results in the evolution of heat and, consequently, goes further to completion at lower temperatures. Extensive calculations have been made on the effect of temperature and pressure on the absorption system. In a particular case, the calculated number of towers to give 95 per cent recovery and 50 per cent acid strength was 11 at 40°C ., nine at 25°C ., and five at 0°C ., all at atmospheric pressure. It would seem desirable, therefore, to use refrigeration in the absorption system, but this has proven too expensive in proportion to the results achieved.

In the pressure process as finally developed (Fig. 29), the gases from the converter are cooled in a heat exchanger, then in a water-cooled coil, and are then passed to oxidation chambers where additional air is added. The gas then goes into the bottom of a

single bubble-cap column made of chrome iron, and this column replaces the entire series of absorption towers. Water is fed to the top of the column, and any nitric acid condensed in the coolers is introduced on an intermediate plate. Cooling means are provided on every plate in the column to remove the heat of reaction and keep the mean temperature of the column as low as the available cooling water will permit.

In a pressure plant, a single converter about 2 feet in diameter delivering to a single bubble-cap column 5 feet in diameter and

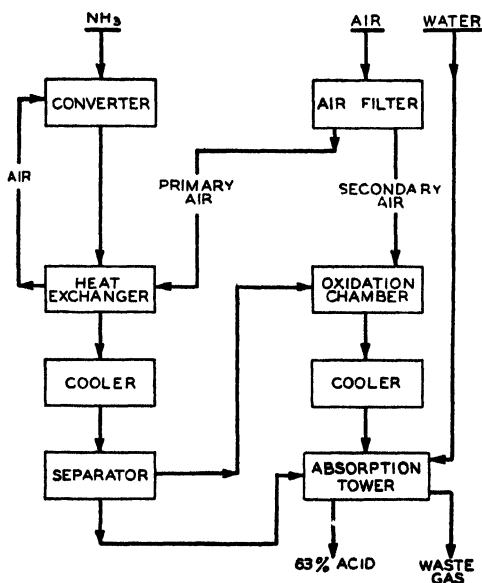

Fig. 29.—Flow sheet for nitric-acid manufacture by ammonia oxidation under pressure.

40 feet high, is capable of producing 25 tons of nitric acid in 24 hours with an overall yield from ammonia to 60 per cent nitric acid of about 93 per cent. A pressure plant requires about one-fifth as much catalyst metal per pound of ammonia burned as does a plant operating at atmospheric pressure. The platinum losses, however, are somewhat greater.

The advantages of pressure operation are: (1) about half the initial investment and (2) an increase of 8 to 10 per cent in the concentration of the nitric acid produced. The product from such a system can easily be held at 60 per cent HNO_3 . In-

ing the strength of the product from 50 per cent to 60 per cent cuts the cost of subsequent concentration almost in half.

Concentration of Nitric Acid.—The strength of the nitric acid ordinarily made by ammonia oxidation in an atmospheric plant is about 50 per cent HNO_3 ; 60 per cent in a pressure plant. The greater part of the nitric acid used in the United States is for organic nitrations. These call for a *mixed acid* containing sulfuric and nitric acids, with less than 10 per cent water. Consequently, for these purposes even a 60 per cent acid must be concentrated to 90 per cent or higher before it can be used.

The water cannot be removed from dilute nitric acid by simple distillation, because nitric acid and water form a constant-boiling mixture at 68 per cent HNO_3 . More dilute acids can be concentrated to this strength, but 68 per cent acid is not strong enough for nitrations.

The usual method for producing strong nitric acid is to distill a mixture of dilute nitric acid and strong sulfuric acid.^(15,16,17) This is usually carried out in a tower of silicon-iron, stoneware, or glass. The feed to the tower is 66° sulfuric acid at the top, and the 50 to 60 per cent nitric acid somewhat below the top. These flow down the tower in countercurrent to an ascending stream of vapor, formed by introducing superheated steam at the bottom of the tower. By properly balancing the nitric and the sulfuric acid in the feed, the vapor leaving the top of the tower can be 90 per cent HNO_3 or better; and the water from the original nitric acid, together with the steam that is condensed in the tower, leave at the bottom as sulfuric acid of not less than 70 per cent H_2SO_4 . If the acid leaving the bottom of the tower is weaker than this, it has a sufficient partial pressure of water vapor to prevent reaching higher concentrations of nitric acid in the top of the tower.

CYANAMIDE PROCESS

This process for the fixation of atmospheric nitrogen depends on the absorption of gaseous nitrogen by calcium carbide to form calcium cyanamide (CaCN_2). At one time it seemed that this process might be the ultimate solution of the problem of nitrogen fixation; but the development of processes for ammonia synthesis, with their simpler plants and lower power consumption, have greatly limited the possibilities of the cyanamide process.

The only large plant in the United States was built by the U. S. government at Sheffield, Alabama, during the First World War, and it was never operated after the close of the war. The American Cyanamid Company of Niagara Falls, Ontario, because of its favorable power situation, still operates on a large scale. It is extremely unlikely that another cyanamide plant will ever be built in the United States.

Manufacture of Calcium Carbide.—Calcium carbide is manufactured by heating a mixture of coke and lime to a high temperature in an electric arc furnace.^(1,18) The furnace consists of a sheet-iron shell, rectangular in shape, lined with refractory brick and then with carbon. In this there may be hung two electrodes for single-phase operation; although present practice is to use three electrodes operating on three-phase current. The charge fills the furnace and surrounds the electrodes to a considerable depth. The current is carried from the electrodes to the charge by short arcs, and through the charge between the electrodes by conduction. The furnace is large enough so that the reacting mass only occupies the center of the furnace, and the walls are never heated up to the reaction temperature of 1800 to 2000°C. Molten carbide collects in a pool at the bottom and is tapped off at intervals and cast into blocks in the case of the smaller furnaces; or tapped continuously onto a bucket conveyer in which it solidifies, in the case of the larger furnaces.

The energy consumption in a large continuous furnace (15,000 kva.) is about 1.35 kilowatt-hours per pound of 80 to 85 per cent carbide. This represents a thermal efficiency of about 80 per cent.

The lime used in the charge is made by burning limestone in a fuel-fired kiln. The carbon used is either coke or anthracite coal. Impurities in the limestone and ash in the coke or coal should be held at a minimum. The limestone is usually selected to contain at least 97 per cent calcium carbonate. Both alumina and magnesia increase the melting point of the carbide and, therefore, make tapping difficult. Iron should be avoided because of the formation of ferrosilicon; and phosphorus must be held extremely low because it forms calcium phosphide in the furnace, and this will liberate phosphine when the carbide reacts with water.

Manufacture of Calcium Cyanamide.—If a current of nitrogen is passed over calcium carbide at a temperature of 1000 to

1100°C., the following reaction takes place:

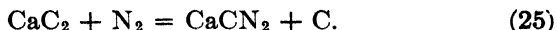

The calcium carbide is first crushed to about 100 mesh in an atmosphere of nitrogen. If 2 per cent of calcium fluoride is added, the reaction temperature may be lowered to 900 to 950°C. In the government plant at Sheffield the ovens consisted of cylindrical steel shells supported on reinforced concrete disks. They were about 3 feet in diameter and 5 feet deep. The shell was lined with insulating and refractory material. The cover was made of steel and was set into a sand seal.

The charge, which was about 1,600 pounds of carbide, was contained in a paper cylinder a few inches smaller than the inside diameter of the furnace. In the center of the charge was a pasteboard tube through which a carbon rod $\frac{1}{2}$ to $\frac{5}{8}$ inch in diameter extended. After placing this charge in the furnace and closing the top, a current was passed through the carbon rod and pure nitrogen (made by the fractional distillation of liquid air) was introduced into the bottom of the furnace. The carbon rod heated the center of the charge to the reacting temperature; but the reaction is exothermic so that once the reaction is well started, the electrical heating was discontinued. After 24 to 40 hours the reaction was completed. After cooling, the crude cyanamide was withdrawn as a single solid block. The present furnaces of the American Cyanamid Company are similar but much larger, handling about 6 tons per charge.

The cooled block of cyanamide is crushed and ground in an atmosphere of nitrogen until 70 per cent will pass a 200 mesh screen. It is sprayed with a small amount of water to decompose any unconverted carbide and phosphide, and if it is to be used directly as a fertilizer, it is sprayed with a small amount of oil to prevent dusting.

Calcium cyanamide is slowly decomposed by water and soil acids, with the liberation of its nitrogen in the form of urea. It can, therefore, be applied directly to the soil as a fertilizer, since its nitrogen is all available. In certain soils there are conditions that make its use undesirable. It is not suitable for use in the manufacture of mixed fertilizers, since the basic cyanamide when mixed with acid phosphate converts the latter to insoluble tricalcium phosphate. From cyanamide, cyanides or urea and many other organic nitrogen compounds may be

prepared. The manufacture of ammonia from cyanamide appears to be obsolete.

References

- (1) CURTIS, H. A., "Fixed Nitrogen." Reinhold Publishing Co. (1932).
- (2) CLARKE, "Data of Geochemistry," *U.S. Geol. Survey, Bull.* 770, p. 255 (1924).
- (3) GRAHAM, H. R., Chap. XXXII in "Industrial Minerals and Rocks," American Institute of Mining and Metallurgical Engineers (1937).
- (4) PARTINGTON, J. R., "The Alkali Industry," D. Van Nostrand Company (1925).
- (5) PARTINGTON and PARKER, "The Nitrogen Industry," D. Van Nostrand Company (1923).
- (6) TOUR, R. S., *Ind. Eng. Chem.*, **13**, 298-302 (1921).
- (7) LARSON *et al.*, *Chem. Met. Eng.*, **26**, 493-497, 555-560, 588-593, 647-654, 683-685 (1922).
- (8) TOUR, R. S., *Trans. Am. Inst. Chem. Eng.*, **20**, 213-249 (1927).
- (9) TOUR, R. S., *Chem. Met. Eng.*, **26**, 245-248, 307-311, 359-362, 411-415, 463-465 (1922).
- (10) BRESLAUER, J., *Chem. Met. Eng.*, **43**, 282-285 (1936).
- (11) PARSONS, C. L., *J. Ind. Eng. Chem.*, **11**, 541-552 (1919).
- (12) PERLEY, G. A., *J. Ind. Eng. Chem.*, **12**, 5-16, 119-129 (1920); *Chem. Met. Eng.*, **22**, 125-129 (1920).
- (13) TAYLOR, G. B., *Ind. Eng. Chem.*, **19**, 1250 (1927).
- (14) TAYLOR, G. B., CHILTON, T. H., and HANDFORTH, S. L., *Ind. Eng. Chem.*, **23**, 860-865 (1931).
- (15) KALTENBACH, M., *Industrial Chemist*, **13**, 176-178 (1937).
- (16) CARPENTER, C. D. and BABOR, J. A., *Trans. Am. Inst. Chem. Eng.*, **16**, 111-148 (1924).
- (17) *Int. Crit. Tables*, **3**, 306-308.
- (18) MANTELL, C. L., "Industrial Electrochemistry," McGraw-Hill Book Company, Inc. (1940).

Problems

1. A stoichiometric mixture of N_2 and H_2 is prepared from pure electrolytic H_2 by burning with air. How many mols of H_2 are present in the final stoichiometric mixture per 100 mols of pure electrolytic H_2 used?

2. A synthetic ammonia plant prepares nitrogen and hydrogen from water gas and producer gas of the following compositions:

Component	Water gas	Producer gas
N_2	3%	63%,
H_2	50%	6%,
CO.....	43%	26%,
CO_2	4%	5%.

These are to be mixed in the proper proportion to provide a stoichiometric mixture of N_2 and H_2 after converting the CO to CO_2 with water vapor. Assume that the converted gas contains 3 per cent CO on the basis of water-free gas. How many mols of water gas and how many mols of producer gas are required to provide 100 mols of dry converted gas?

3. 100 mols of dry converted gas contains

N_2	17.18 mols,
H_2	51.55 mols,
CO.....	3.0 mols,
CO_2	28.27 mols.

The CO_2 is completely scrubbed out with water under 50 atmospheres total pressure. The water reaches 90 per cent saturation with CO_2 (see table XXV) and leaves the scrubber at 68°F. Neglect the effect of other dissolved gases on the solubility of CO_2 in water.

How many cubic feet or gallons of water are required per 100 mols of dry converted gas?

4. From the data of Fig. 25, calculate the equilibrium concentration of ammonia at 5,000 pounds per square inch absolute pressure and 450°C., in a stoichiometric mixture of nitrogen and hydrogen. Assume that the gas laws hold.

5. What would be the per cent NH_3 at equilibrium at 500°C. and 5,000 pounds per square inch, of a gas containing initially 50 mols of N_2 and 50 mols H_2 ? Assume that the gas laws hold.

6. A synthetic ammonia converter gas containing 25 per cent NH_3 is refrigerated at 4,800 pounds per square inch for separation of the NH_3 . At the exit conditions the vapor pressure of ammonia is 97 pounds per square inch. What per cent of the ammonia may be removed as liquid? Assume that the gas laws hold.

7. An ammonia plant is operating as shown in Fig. 24. The composition of the gas leaving the "rugged" converter is:

N_2	22.7 mol per cent,
H_2	68.1 mol per cent,
NH_3	9.2 mol per cent.

If the pressure in the system is 5,000 pounds per square inch and the temperature such that the vapor pressure of NH_3 is 135 pounds per square inch, how many mols of NH_3 will be condensed in the "rugged" condenser per 100 mols of electrolytic H_2 originally charged to the burner?

8. In the plant of Problem 7 the gas leaving the active converter contains 11.53 per cent NH_3 and the gas leaving the active receiver contains 1.67 per cent NH_3 .

a. How many mols of NH_3 are removed from the active receiver per 100 mols of H_2 originally charged?

b. The pressure of the recirculated gas is 5,000 pounds per square inch, the temperature is 16°F., this gas behaves so that $PV = 1.3NRT$. How many cubic feet of gas (at 16°F., and 5,000 pounds per square inch) are recirculated per 100 mols of H_2 originally charged?

9. In a pressure plant for oxidizing NH_3 to HNO_3 , the gas entering the converter contains 10 per cent NH_3 by volume (dry basis), and 96 per cent of the NH_3 is converted to NO . The balance is converted to N_2 and H_2O . What is the analysis (dry basis) of the gas leaving the converter?

10. The above converted gas goes to a cooler, where nitric acid of 40 per cent HNO_3 by weight is recovered. If the gas leaving the cooler contains the same number of mols of H_2O as the air used for the NH_3 oxidation, how many mols of 40 per cent HNO_3 are removed from the cooler per 100 mols NH_3 entering the converter?

11. In the pressure plant of Problems 9 and 10, the total recovery of HNO_3 , in the form of strong acid leaving the absorption tower, is 94 per cent of that theoretically obtainable. The 40 per cent acid from the cooler enters this tower. What is the yield of 63 per cent acid obtained from this tower, in pounds per 100 mols of NH_3 oxidized, assuming that it contains no dissolved oxides of nitrogen?

If 142 mols of secondary air per 100 mols of ammonia entering the converter are added between the cooler and the absorption tower, what is the analysis (on a water-free basis) of the gas leaving the top of the tower, if oxides of nitrogen present are all calculated as NO ?

12. In an atmospheric-pressure plant for the oxidation of ammonia, HNO_3 is formed only in the absorption tower. Such a plant makes 30 tons of 50 per cent HNO_3 per day. If 1042 mols of air are used per 100 mols of NH_3 , and 96 per cent of the NH_3 is converted to NO , what should be the total volume of the absorbing towers? If the gas passes through the towers in series, calculate the tower diameter, and the number of HNO_3 towers if these are 40 feet to 60 feet high. Assume these towers operate at an average temperature of 85°F ., and the recovery of HNO_3 is 90 per cent of that theoretically obtainable from the NH_3 .

13. A plant is to concentrate 60 per cent HNO_3 , by distilling with H_2SO_4 , to produce 15 tons per day of 98 per cent HNO_3 . The liquid from the base of the tower contains 70 per cent H_2SO_4 and 30 per cent H_2O .

- a. If the still is heated by a closed coil, how many tons of 60 per cent HNO_3 and 66°Bé . H_2SO_4 are fed to the top of the column, and how many tons of 70 per cent H_2SO_4 are removed from the base of the column per day?
- b. If the distillation is carried out by blowing 0.6 ton of superheated steam into the base of the column per ton of 98 per cent HNO_3 made, how many tons of 66°Bé . H_2SO_4 must be added to the top of the column per day?

CHAPTER V

HYDROCHLORIC AND PHOSPHORIC ACIDS

This chapter will cover the manufacture of hydrochloric and phosphoric acids. These are fairly important in their particular fields, but do not have such an extensive use as the acids previously mentioned. They will be treated briefly, since for the student of technology they hold less interest than the acids of major importance.

HYDROCHLORIC ACID

The U. S. Census of Manufactures gives the following figures for the production of hydrochloric acid:

TABLE XVI.—PRODUCTION OF HYDROCHLORIC ACID
(Short Tons of 100 Per Cent Acid)

Source	1937	1939
From salt.....	53,000	53,000
From chlorine.....	10,000	10,000
By-product.....	8,000	16,000
Total.....	71,000	79,000

Commercial hydrochloric acid is sold as 18°Bé. (27.92 per cent HCl), 20°Bé. (31.45 per cent HCl), and 22°Bé. (35.21 per cent HCl). Hydrochloric acid is used for so many purposes that consume relatively small amounts, that figures for its distribution are difficult to obtain and are not precise.

Hydrochloric acid attacks all metals of which vessels for storing or shipping may be made. In small lots it is stored and shipped in glass carboys or rubber-lined drums. Rubber-lined tanks have been widely used for storing hydrochloric acid, and rubber-lined tank cars have become the universal means for shipping hydrochloric acid in quantity.

Manufacture from Salt.—The classical method for the manufacture of hydrochloric acid is the treatment of sodium chloride

with sulfuric acid.⁽¹⁾ These react in two steps:

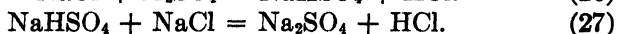

The first of these reactions takes place fairly readily and requires only a slight elevation in temperature. In order to make the second reaction take place, the mixture must be heated to a relatively high temperature. The salt is completely decomposed only at a red heat and in the presence of a slight excess (0.1 to 0.2 per cent) of sulfuric acid. It is obvious that instead of using sulfuric acid and salt, niter cake and salt could be used. In this case, only the second reaction is involved. To be marketable, sodium sulfate must be porous rather than fused and, hence, the second stage of the reaction must be carried out at a temperature below the melting point (843°C.). This product is usually known in the trade as *salt cake*, and is the principal source of technical sodium sulfate.

Salt-cake Furnaces.—The first step in the reaction offers no special mechanical difficulties since through the greater part of this stage there is enough liquid sulfuric acid present to prevent the mass from becoming solid. This step can be carried out in cast iron and is usually done in batches. After the first stage is finished, the reacting substances are both solids and therefore require some type of apparatus in which they can be mixed or stirred. This was originally done by hand, and hand-rabbed furnaces still exist. Much time and energy have been spent in attempting to devise mechanically stirred furnaces. The problems were: first, resisting the corrosive conditions in the furnace; second, resisting the effect of high temperatures; and third, stirring a charge that was initially fluid, passed through a pasty stage, and then became solid. The solution of these problems was accelerated by the increasing difficulty of obtaining labor for the extremely unpleasant task of operating hand-rabbed furnaces. At present, much of the hydrochloric acid made in the United States is made in some type of mechanical furnace.

Figure 30 represents a combination pot-and-muffle installation. A is a shallow cast-iron pan about 10 feet in diameter, in which the first reaction takes place. This is mounted in a brick setting in such a way that it is heated by the flue gas on its

way to the stack. A charge of 1,200 to 1,600 pounds of salt and the equivalent amount of 60° acid is placed in this pan and allowed to react, with an occasional stirring, until the first stage is finished. The mass is then worked through the passage *B* onto the hearth *C*. This hearth is long enough to accommodate a number of charges from the pan, and they are gradually

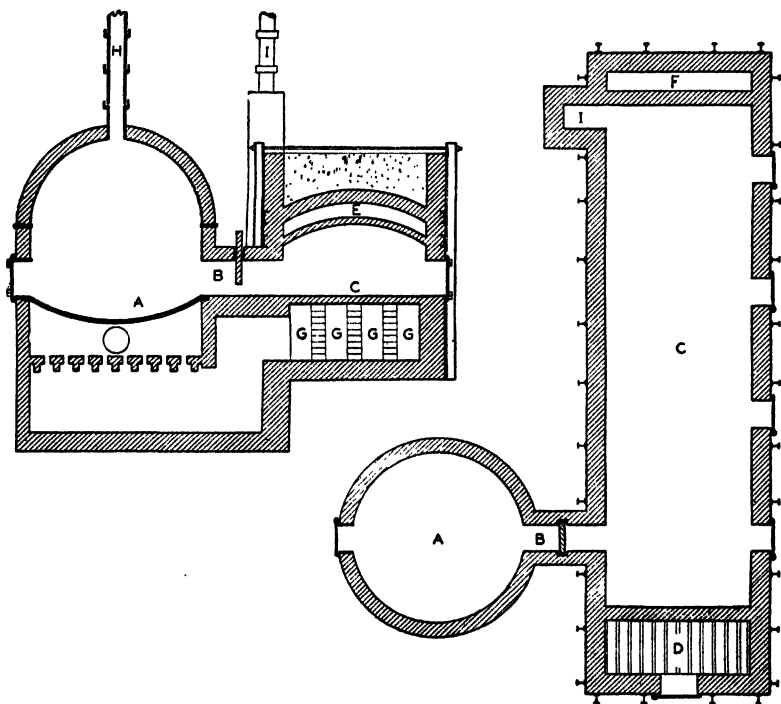

FIG. 30.—Pot-and-muffle furnace for hydrochloric acid.

worked along the hearth and finally withdrawn through the end door. Coal is burned on the grate *D* at one end of the hearth; and the flue gas rises through a port above the grate and travels over the hearth through the flue *E*. At the rear of the hearth the flue gas passes down through the port *F*, back under the hearth through the flues *G*, under the pan, and out to the stack. Hydrogen chloride* is removed under slight suction

* The term *hydrogen chloride* will be used to refer to the chemical compound HCl ; while the term *hydrochloric acid* will refer to a solution HCl in water (also known as *muratic acid*).

to minimize its escape through unavoidable leaks in the brickwork. This dilutes it with air, and the dilution is greater in the gases removed from the muffle (flue *I*) than in those from the pot (flue *H*). These gases are collected and absorbed separately, because it is possible with the latter to produce a stronger acid. The maintenance of the furnace is especially difficult because of the combined action of high temperatures, acid, and nearly-fused salts. Unavoidable leaks from such a

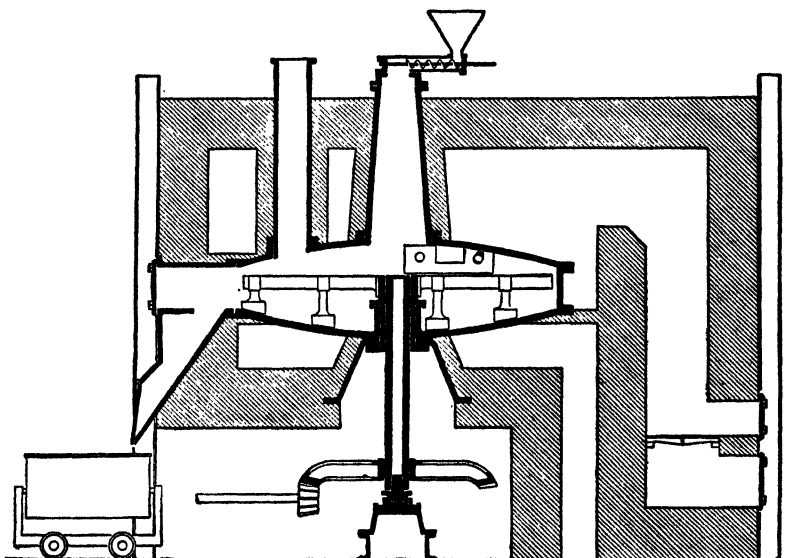

FIG. 31.—Mannheim furnace.

plant may constitute a nuisance and prohibit its operation in populous districts.

The *Mannheim furnace*, developed in Germany, is used at present in the United States. In this (Fig. 31) there is a stationary cast-iron pan similar to the pan of Fig. 30. In the center of the pan is a shaft driven from below and carrying arms on which are scrapers. The feed enters through the center of the cover, and may be sulfuric acid and salt or granulated niter cake and salt. The scraper blades are set at an angle, so that they work the material from the center toward the periphery where it is discharged. The furnace operates continuously. All the metal parts in contact with the charge are usually made of cast iron.

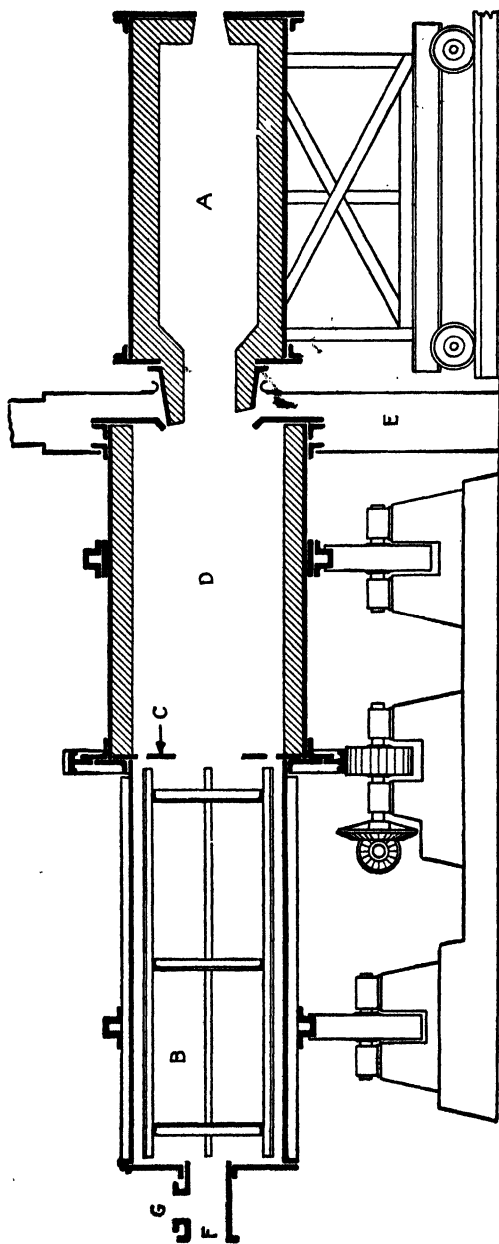

FIG. 32.—Laury furnace.

The *Laury furnace* (Fig. 32) is also in use in the United States.⁽²⁾ It consists of a horizontal rotating cylinder. At one end is a combustion chamber *A*, arranged for oil firing. This chamber is set on a truck so that it can be moved out of the way. The cylinder is divided into two parts; and the charge enters the small end through *G*. The smaller chamber, *B*, is lined with chilled cast-iron plates and carries a loose cage made of steel rails. The first stage of the reaction takes place here; or if the charge is salt and niter cake, this chamber serves to grind and mix the charge and start the reaction. Between the grinding chamber and the hot chamber is a cast-iron plate *C*, with a hole in the center for gas, and radial slots near the periphery for gradually transferring the ground material to the hot chamber *D*. In this hot chamber, the reaction is finished. A loose rail is usually placed here to prevent crust from forming. The furnace discharges continuously into a sheet-steel housing *E*, and by proper control of the temperature the reaction can be completed without making a fused product. The hydrogen chloride formed by the reaction, diluted with combustion gas and air, is withdrawn through *F*. It contains about 5 per cent HCl, and is first sent to a dust chamber, and then to the absorption system. In this furnace, as in the Mannheim, only one grade of gas is made whether the feed is sulfuric acid or niter cake.

Theory of Absorption.—In absorbing a gas in a liquid the maximum concentration which can be obtained in the solution is such that the partial pressure of the gas from the solution is equal to its partial pressure in the gas phase. If the partial pressure of gas from the solution is less than its pressure in the vapor phase, absorption will take place; and the rate of absorption will depend on this difference in pressures. If the principal resistance to absorption is on the gas side of the gas-liquid interface (which is the case in this system and, in general, for most very soluble gases) the rate of absorption may be expressed by the equation

$$\frac{dW}{d\theta} = KA\Delta p; \quad (28)$$

where $\frac{dW}{d\theta}$ = weight of gas absorbed in unit time,

K = a proportionality constant depending on the system and on certain conditions in the absorbing apparatus.

A = area of contact between gas and liquid,
 Δp = driving force, or difference between the partial pressures of the soluble gas in two phases.

TABLE XVII.—PARTIAL PRESSURE OF WATER VAPOR OVER HCl SOLUTIONS
 (Millimeters of Mercury)

Percentage HCl	Degrees Centigrade						
	0	10	20	30	50	80	110
10	3.84	7.70	14.6	26.8	80.0	310	960
20	2.62	5.40	10.3	19.0	57.0	230	729
24	2.05	4.31	8.30	15.4	46.7	194	611
28	1.50	3.21	6.32	11.8	36.5	154	499
32	1.04	2.27	4.55	8.70	27.7	120	396
36	0.68	1.50	3.10	6.08	20.4	90.0	311
40	0.41	0.94	2.00	4.09	14.5	67.3	230

PARTIAL PRESSURE OF HCl OVER ITS AQUEOUS SOLUTIONS
 (Millimeters of Mercury)

Percent- age HCl	Degrees Centigrade						
	0	10	20	30	50	80	110
4	0.000018	0.000069	0.00024	0.00077	0.0064	0.095	0.93
8	0.000118	0.000583	0.00178	0.00515	0.0344	0.39	3.10
12	0.00099	0.00305	0.0088	0.0234	0.136	1.34	9.3
16	0.0056	0.016	0.0428	0.106	0.55	4.66	28
20	0.0316	0.084	0.205	0.48	2.21	15.6	83
24	0.175	0.43	1.00	2.17	8.9	54.5	253
28	1.0	2.27	4.90	9.90	35.7	188	760
32	5.7	11.8	23.5	44.5	141	623	
36	29.0	56.4	105.5	188	535		
40	130	233	399	627			
44	510	840					

Consequently, in order to predict the strength of hydrochloric acid that may be made from a gas of a given strength, it is necessary to know the vapor pressure of hydrochloric acid exerted by solutions of different strengths. Zeisberg⁽³⁾ has published data from which the values in Table XVII are abstracted.

Intermediate values may be calculated from the formula

$$\log P = 10.9528 - 0.009725W - 0.000868W^2 - \frac{4557 - 65.3W}{T}; \quad (29)$$

where P = pressure of HCl in millimeters mercury.

W = per cent of HCl in solution by weight.

T = absolute temperature in degrees Kelvin.

This formula is accurate to 5 per cent for acids from 18 to 32 per cent and temperatures from 0 to 100°C.

It will be noted that solutions under 20 per cent exert low partial pressures of hydrochloric acid and, therefore, will be in equilibrium with very dilute gases. Consequently, it should be possible to remove hydrochloric acid almost completely, even from gases containing low percentages, by scrubbing with water, provided it is not necessary to produce high-density acid. On the other hand, strong hydrochloric acid solutions even at low temperatures exert considerable partial pressures of hydrochloric acid, and consequently the strength of solution that can be prepared is limited. It should also be noticed that the vapor pressures, especially of the more concentrated solutions, increase rapidly with temperature; and therefore it is necessary that the absorption be carried out at as low a temperature as possible.

In Fig. 33 there are plotted equilibrium concentrations of hydrochloric acid in the liquid and gas phases at 30 and 80°C. (curves 1 and 2). Vapor concentrations are expressed as partial pressures of hydrogen chloride in millimeters Hg, and liquid concentrations as mol fractions of hydrogen chloride. Suppose it be required to produce an acid of 22°Bé. with a 30 per cent gas at 30°C. In this case, at 1 atmosphere total pressure, the partial pressure of HCl in the gas phase will be 228 millimeters. Since 22°Bé. acid contains 35.21 per cent HCl, the mol fraction of HCl in the liquid phase is 0.21. These concentrations of liquid and gas locate point *A*, which represents conditions at the strong end of the absorption system where finished acid is in contact with the entering gas. It may be assumed that the concentration of HCl in the exit gas is 0.3 per cent, which corresponds to a partial pressure of 2.3 millimeters. Fresh water is fed to the system, so the mol fraction of HCl in the incoming liquid is zero. This locates point *D*, which represents conditions at the weak end of the absorption system where the exit gas is in contact with fresh water. A line can be drawn between points *A* and *D*, that will indicate compositions of gas and liquid phases at various points in the apparatus.^(4,5)

The composition of the vapor phase in equilibrium with 22°Bé. acid, point *B*, is only 135 millimeters (18 per cent HCl). It is obvious that 30 per cent gas (228 millimeters) is much stronger than the equilibrium concentration and therefore will be rapidly absorbed in 22° acid. The driving potential, or difference in partial pressure of hydrogen chloride in the gaseous and liquid phases, at this point in the apparatus, is represented by the length of the line *AB*. In the same way at any other point in the apparatus, the driving potential is the vertical distance

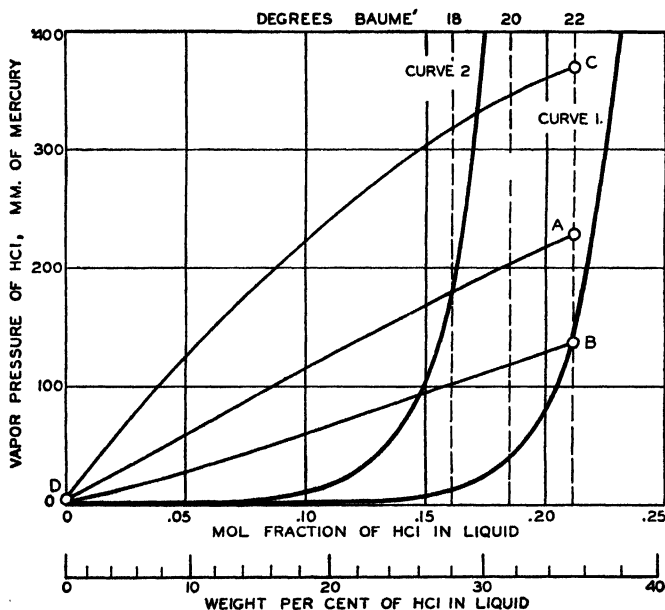

Fig. 33.—Vapor pressures of hydrochloric-acid solutions.

between the line *AD* and curve 1. The line *BD* represents conditions for absorption from the poorest gas with which it is theoretically possible to make 22° acid at 30°C. Since, however, in this case the liquid and gas phases would be in equilibrium at one end of the system, the driving force would be zero at that point and, consequently, an apparatus to operate under these conditions would have zero capacity. Line *CD* represents absorption from a gas containing 50 per cent HCl, and shows that if this gas were used to produce 22°Bé. acid there would be an average driving potential over the whole apparatus approxi-

mately twice as great as with 30 per cent gas. Hence the former gas will need only half the contact surface required by the latter.

Curve 2 represents the equilibrium vapor pressure of hydrochloric acid at 80°C. It will be noted that this does not intersect the abscissas for either 20 or 22° acid within the limits of the chart. In order to produce either of these acids at 80°C.; therefore, a gas of more than 50 per cent HCl will be necessary. The gas in equilibrium with 18°Bé. acid at 80°C. has a partial pressure of hydrogen chloride of 188 mm. (24.7 per cent); whereas at 30° the equilibrium partial pressure is only 9.9 mm. or about 1.3 per cent. For acids below 0.10 mol fraction hydrogen chloride (18 per cent acid), the vapor pressure at 80° is so little above the vapor pressure at 30° that there is practically the same vertical distance between either of these vapor pressure curves and the lines *AD* or *CD*. In other words, solutions of these or lower concentrations exert so little vapor pressure at any temperature, that temperature does not seriously affect the driving potential that causes absorption. The reverse is true for more concentrated acid. Curves 1 and 2 show how an increase from 30 to 80° will greatly decrease the final concentration of acid that can be made from any given gas. Consequently, in actual operation it will be necessary to keep the temperature low in the part of the absorbing system where the absorbing liquid is strong, while temperature will be a matter of indifference in those parts of the system where the absorbing liquid is weak.

Even though the gases are cooled to approximately room temperature before entering the absorption system, there will

TABLE XVIII.—HEAT OF SOLUTION OF HYDROGEN CHLORIDE

<i>n</i> = 1	5	10	50	100	300
9,666	26,928	29,088	30,780	30,960	31,140

be heat evolved from the reaction between hydrogen chloride and water. The amount of heat (in B.t.u.) evolved when 1 pound mol of HCl is dissolved in *n* pound mols of water is shown in Table XVIII. It is obvious that if a low temperature is to be maintained, the absorption system must be so designed that this heat can be dissipated readily.

Absorption Systems.—The treatment of the gas after it leaves the furnace consists usually of three steps: first, cooling; second, purifying; and third, absorption in water.

The gases will vary in composition from 70 per cent HCl, which is the product of the pots, to 30 per cent for furnaces of the hearth or Mannheim type; and as low as 5 per cent in the Laury furnaces. The temperatures of these gases will vary between 840° from the Mannheim to 300° from the Laury. Cooling is accomplished in silica S-bends or in a long run of stoneware pipe. Several stacks of these S-bends are placed in parallel so that the gas velocity inside the pipes is from 5 to 15 feet per second. Water may be sprayed on the later sections, and the gas temperature is finally reduced below 100°F.

Hydrochloric acid containing 0.5 per cent of sulfuric acid is acceptable for some purposes, but the usual requirement is that it be below 0.1 per cent. After cooling, sulfuric acid is present as a mist and is removed by filtration. The filter consists of a box made of stone slabs or, preferably, of short stoneware towers. This filter is packed with fine coke to a depth of about 30 inches, and an area of about 1 square foot for every 5 cubic feet of gas per minute has been suggested. Stoneware towers may be placed in parallel to give the requisite cross-sectional area.

The rate of absorption of hydrochloric acid by water is so rapid that for stronger gases it is not necessary to use elaborate apparatus to bring the gas into intimate contact with the absorbing liquid. It is, in fact, desirable that the gas be merely passed over the surface of a body of water so that the absorption may not be too rapid and the heat of solution evolved in too concentrated a form. As the gas becomes dilute and the driving potential small, it is desirable to use a packed tower in which the contact between gas and liquid is more thorough. In this part of the system, the amount of gas absorbed (and therefore the amount of heat liberated as heat of solution) is small, and the maintenance of a low temperature is relatively unimportant. Hence, special means for dissipating heat are unnecessary and, therefore, tower construction is satisfactory.

The gas entering the absorption system first passes through Cellarius tourills, or Wolff bottles, which are arranged to be cooled either by air or water. These are shown in Fig. 34. A number of these units are connected in series and arranged in

cascade so that the gas to be absorbed enters at the lower end of the cascade, and the absorbing liquid, usually dilute hydrochloric acid, enters at the upper end. If water cooling is to be used, as is ordinarily the case with tourills, they are set in a large wooden tank and partly immersed in water. The design of all these vessels is such that the gas comes into contact with only the surface of the liquid in them. When using a gas of moderate

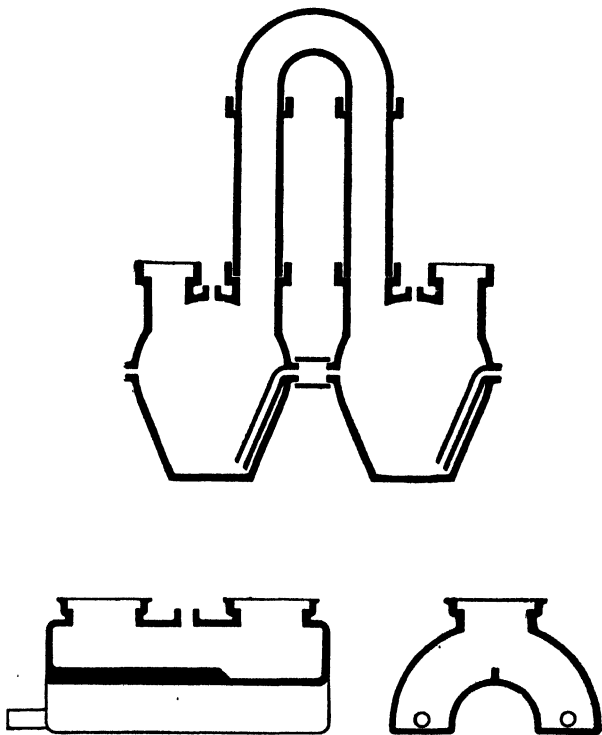

FIG. 34.—Tourills and Wolf bottles.

concentration, the amount of absorption taking place in each vessel is small, and because of the large surface exposed for cooling it is possible to dissipate the heat of absorption, and to prevent the temperature of the absorbing liquid being much above the temperature of the cooling medium. Most of the absorption takes place in this series of vessels and the gas leaving them is therefore comparatively dilute. This dilute gas passes through one or more absorption towers packed with stoneware

shapes or coke. Water for the absorption enters the last of these towers, progresses in a general way countercurrent to the flow of gas, and enters the tourill at the higher end of the cascade. As the amount of water required for the absorption is far too small to wet the packing of the entire cross-section of the tower satisfactorily, it is necessary to recirculate the absorption liquid over each tower, as is the case for nitric acid towers. This recirculation is usually accomplished by means of air lifts. Water entering the last tower of the series causes the acid from that tower to overflow from the catch basin at the bottom of the tower into the catch basin of the next tower and thus finally to the tourill system.

TABLE XIX.—DATA FROM TOURILL SYSTEM

Gas			Liquor		
Tourill number	Temperature	Percentage HCl	Temperature	Baumé at 15.5 degrees Centigrade	Percentage HCl
1	26.1	73	35.8	22.8	36.7
12	38.8	64	20.0	22.4	36.0
23	31.0	50	51.0	20.9	33.1
33	48.7	49	70.0	18.7	29.1
46	59.0	31	80.0	11.3	16.8
57	54.0	2	12.6	1.0	1.4

Table XIX gives data taken on a tourill system absorbing strong gas.

It will be noted that, due to the high concentration of hydrogen chloride, and the consequent rapid absorption of gas in parts of the system, there was inadequate removal of heat and the temperature of the absorbing liquid rose 70°C. above the temperature of the cooling water. This did not occur in the first tourills where the gas was concentrated, but later in the system where the absorbing liquid was dilute. A plot similar to Fig. 33 would show that in the latter case there was a larger driving potential than with strong gas in contact with strong liquid.

These data indicate the desirability of a better means for dissipating the heat of solution. Fused silica can be made thinner-walled than stoneware, and has a better thermal con-

ductivity. The ordinary silica S-bends which are used for cooling may be modified into absorbing vessels as shown in Fig. 35.^(6,7) A ridge, pressed into the under side of the lower bend holds back a pool of liquid, and the area of this pool is increased by flattening the bottom of the tube. In this way the bend functions exactly like a tourill.

For gas of very high concentration, such as is obtained from synthetic hydrochloric acid and by-product hydrochloric acid plants, the rate of absorption is extremely high, and the problem becomes principally one of removing the heat of absorption.

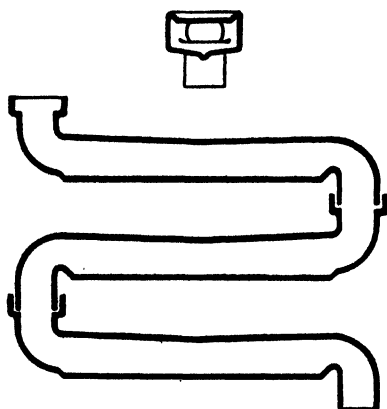

FIG. 35.—Tyler S-bend absorbers.

For such strong gases, which frequently contain over 90 per cent HCl and seldom contain less than 70 per cent HCl, an absorber of tantalum⁽⁸⁾ has been developed. This is illustrated in Fig. 36. It consists essentially of a short stoneware absorbing tower, *A*, and a tantalum absorber and cooler, *B*. Gas enters at *D* and passes up through packing in section *A*. Section *B* consists of an inner tapered tube of tantalum filled with small tower packing.

Surrounding this is a slightly larger tapered iron tube, *C*. The residual gas leaves the apparatus at *E*, water for absorption enters at *H*, and strong acid leaves the absorber at *F*. This acid is hot, and so passes through a tantalum double-pipe heat exchanger (not shown).

Cooling water passes first through this heat exchanger and then at *G* into the space between tubes *B* and *C*. The tantalum wall is extremely thin and has a very high coefficient of heat transfer, so that in section *B* the heat of solution is effectively removed.

Such a system as is shown in Fig. 36 is suitable for gases containing over 85 per cent HCl. If the gas is as high as 98 per cent HCl, the absorbing tower *A* can be omitted, and the apparatus consists substantially of section *B* with the proper connections.

Synthetic Hydrochloric Acid.—In the electrolytic process for manufacturing sodium hydroxide, hydrogen is liberated at the

cathode and chlorine at the anode. Some electrolytic caustic plants have installed apparatus in which hydrogen is combined with chlorine to make hydrochloric acid. This process is simple

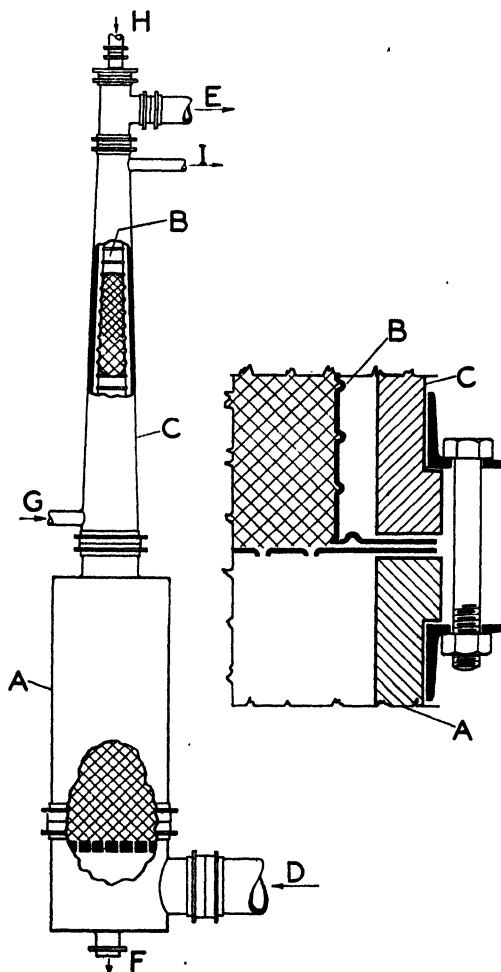

FIG. 36.—Tantalum absorber for hydrochloric acid. (Courtesy of Fansteel Metallurgical Corporation.)

and produces a very pure acid. The extent to which this process will develop will be determined by the market for chlorine, and by the demand for sodium sulfate as a by-product from the salt-cake process.

The plant consists of a quartz bunsen burner in which hydrogen burns in chlorine, followed by an absorption system. This burner may be swung to one side of the apparatus and the hydrogen ignited in air. The burner is then swung under a quartz sleeve and chlorine is introduced so that the hydrogen burns in an atmosphere of chlorine, giving hydrogen chloride. Some installations use a large combustion chamber partly filled with broken refractory material and having an explosion vent; and some patents specify the use of an excess of hydrogen which is collected at the end of the absorption system and returned to the burner. The simpler plant first described is, however, preferred in commercial operation.

Acid is produced from this hydrogen chloride in much the same apparatus as is used with salt-cake furnaces. The gas must first be cooled in silica S-bends. The purifying chamber may be omitted since there is neither dust nor sulfuric-acid mist to be removed. The absorption system may be any of the systems described above. Due to the very high concentration of hydrogen chloride and the small percentage of inert gas, the absorbing system is relatively simple. In fact with gas approximately 100 per cent HCl, absorption can be made complete in a very few S-bends or in a tantalum absorber without any scrubbing towers on the end of the system.

There is a marked demand for water-white acid. Minute traces of iron give a decided yellow color to hydrochloric acid. If water-white acid is to be produced, coke-packed towers may not be used since the coke contains enough soluble iron to color the acid strongly. Unglazed stoneware will also yield a colored acid, and even glazed stoneware will give up iron for a period of many months. The synthetic process, using a silica or tantalum absorption system, readily gives water-white acid. It is exceedingly difficult to make water-white acid by the salt-cake method.

By-product Hydrochloric Acid.—Many organic syntheses that are carried out on a large scale yield hydrochloric acid as a by-product. A typical example is the manufacture of chlorobenzene. The reaction is

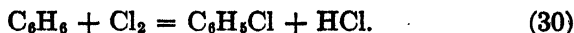

The gas coming from the apparatus consists of hydrogen chloride,

inert gas which was present in the original chlorine, and excess chlorine. This mixture is also saturated with volatile constituents which, in the above case, are benzene and chlorobenzene. Before absorbing the hydrogen chloride, it is necessary to remove the benzene and chlorobenzene vapors. This is done by cooling to a low temperature, first in water-cooled lead coils, and then by passing the gas up through a small packed tower in countercurrent with refrigerated chlorobenzene. The gas remaining after this process is then sent to an ordinary hydrochloric-acid absorbing apparatus. The solubility of chlorine decreases rapidly as the concentration of hydrochloric acid increases, so that the finished acid does not ordinarily need to be treated to remove this dissolved chlorine. Since the exit gas from the absorption system will carry chlorine, it cannot be discharged into the air but must be sent to some apparatus, such as a milk-of-lime tower, for further scrubbing.

PHOSPHORIC ACID

Although phosphoric acid is an important product, statistics on the relative use of different processes of manufacture and on its distribution are not available. The usual grades on the market are 50 per cent, 75 per cent, and 85 per cent H_3PO_4 . More recently phosphoric acid has become available that contains up to 84 per cent P_2O_5 . This is equivalent to 116 per cent H_3PO_4 ; and has the same relation to ordinary phosphoric acid that oleum has to sulfuric acid. The principal uses of phosphoric acid are in the manufacture of baking powder, carbonated drinks and soda-fountain sirups, and phosphates, of which the most important is trisodium phosphate. Another important use that has been gaining in volume in recent years is in connection with the rust-proofing of iron.

Phosphoric acid up to 75 per cent may be shipped in glass carboys, or in rubber-lined or lead-lined tank cars. Stronger acids attack lead and have enough affinity for water to carbonize organic materials. Such acids may be shipped in glass. If they contain a few tenths of a per cent H_2SO_4 , a protective film of $PbSO_4$ develops on lead, and they may be shipped in lead-lined tank cars.

Sulfuric Acid Method.—For many years the only method for the manufacture of phosphoric acid was the treatment of ground

phosphate rock with sulfuric acid.⁽⁹⁾ The reaction is approximately



Since phosphate rock contains fluorides, hydrofluoric acid is also formed. Some is evolved as a gas, but much remains in solution. For this reason some manufacturers of phosphoric acid to be used for baking powder and other food purposes have used calcined bones instead of phosphate rock, since bones are nearly free from fluorine. There is relatively little bone acid made at the present time.

The original method of carrying out reaction (31) was to treat the ground rock with sulfuric acid in lead-lined tanks heated with lead coils. This gave a reaction mixture containing unconverted rock and a bulky precipitate of calcium sulfate. The mixture was allowed to settle, and as much clear liquid as possible was drawn off as a solution of 12 to 18 per cent P_2O_5 . The precipitated calcium sulfate was filtered and washed, and the wash added to the next batch. The clear acid was given various treatments to purify it and was then concentrated.

The evaporation of phosphoric-acid solution is difficult for two reasons. In the first place, phosphoric acid is very corrosive so that only lead or Duriron may be used. If the acid is to be used for food products, a difficulty with lead lies in the possibility of more lead being in the acid than is permissible under government regulations. In the second place, the solution is saturated with calcium sulfate, which results in serious difficulties from scale. Present practice is to use multiple-effect cast-lead evaporators with lead-covered copper tubes. In some plants, before the solution goes to evaporators, it is showered down through a tower in counter-current with hot stack gases. This accomplishes considerable evaporation; precipitates much of the calcium sulfate as a sludge that may be settled out in receivers at the base of the tower; and most important of all, it displaces most of the dissolved hydrofluoric acid.

The sulfuric acid process has been greatly modernized by the introduction of better engineering principles.^(10,11) The raw rock is usually ground in a special ball mill in a weak solution of phosphoric acid, and is then sent to apparatus in which the final

reaction with sulfuric acid takes place. This may be a series of Dorr agitators* or other similar agitating devices.

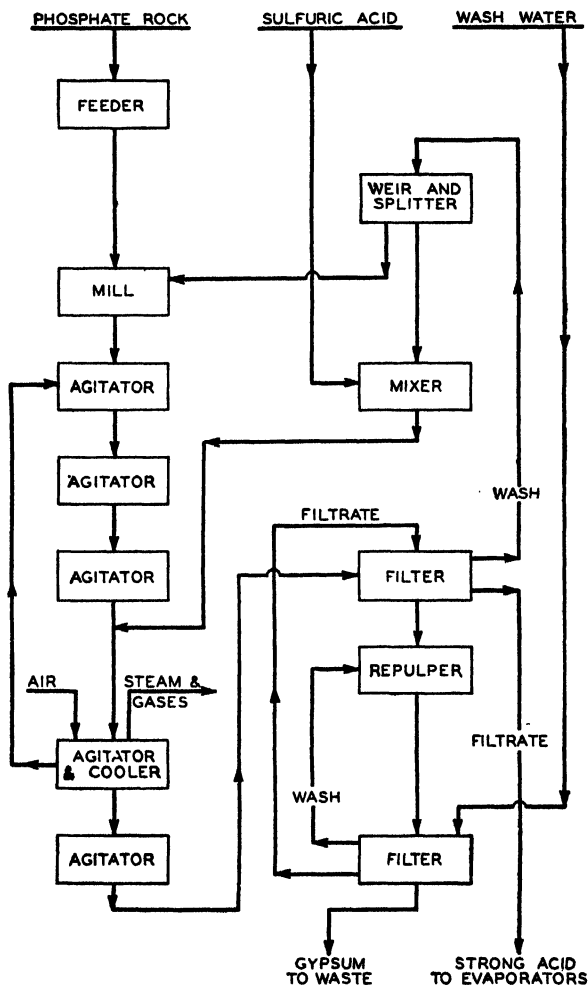

Fig. 37.—Flow sheet for phosphoric-acid manufacture by wet process.

The separation of the acid from the precipitate and the washing of the precipitate is carried out in a Dorr continuous counter-current decantation system,* or on rotary continuous filters.

* Dorr equipment and countercurrent decantation systems are described on p. 154.

The countercurrent decantation system gives a final product containing 20 to 22 per cent P_2O_5 . The subsequent introduction of rotary continuous filters raised this to 30 to 32 per cent P_2O_5 .

A flow sheet for a plant of the latter type for carrying out the sulfuric acid process⁽¹²⁾ is shown in Fig. 37. Raw phosphate rock is ground in a ball mill in dilute phosphoric acid obtained as filtrate later in the process. The pulverized material flows through five Dorr agitators in series. Between the third and the fourth agitators, there is introduced the necessary amount of sulfuric acid diluted with filtrate. From the fourth agitator a considerable amount of the reaction mixture is pumped back to the first agitator in the series. The purpose of this is so to adjust acid concentrations and times of reaction that the calcium sulfate formed is in sufficiently large crystals to be readily filtered and washed. The heat of reaction is considerable, and is removed in the fourth agitator by blowing air through the solution. This causes enough evaporation to carry off the excess heat of reaction as latent heat and results in the evaporation of an appreciable amount of water from the system. From the fifth agitator the slurry goes to a rotary continuous filter. The filtrate from this is the finished product at 30 to 32 per cent P_2O_5 . The wash from this filter is the dilute phosphoric acid solution used in the ball mill, and used for diluting the incoming sulfuric acid. The precipitate from this filter is repulped with more liquid and filtered on a second filter, where it is washed with fresh water. The filtrate from this second filter is the wash liquid for the first filter, and the wash liquid from the second filter is used for repulping the precipitate from the first filter.

The evaporation involved in the cooling process in the fourth agitator permits the use of 25 per cent more wash water on the last filter than would otherwise be permissible. The process dissolves 95 per cent of the P_2O_5 in the rock and of this, 97 to 98 per cent is recovered as finished acid.

In practically all plants in the United States the precipitate of calcium sulfate from this process is a waste material. At one plant it has been used for the manufacture of building blocks.⁽¹³⁾

If a more concentrated acid is required than is produced from the filtrate, it may be concentrated by the methods described above,

Electric-furnace Process.—In this process phosphate rock, coke, and quartz rock are charged into the shaft of an electric furnace.^(14,15) In the shaft hang three electrodes which are connected to a three-phase alternating current. As the charge descends in the shaft and reaches the level of the arc, it is fused. The reaction is approximately



The phosphorus is volatilized and ascends the shaft with the carbon monoxide that is formed by the reaction. At the side of the shaft near the top there is a gas off-take. A suction, induced by means of fans, draws phosphorus vapor and carbon monoxide up through the shaft, and a current of air down through the charge. These two currents mix in the flue at a temperature sufficient to burn the carbon monoxide to dioxide and the phosphorus to phosphorus pentoxide. The gas is cooled by passing through a long flue. A small amount of water is sprayed into the gas, and this reacts with the phosphorus pentoxide to form a mist of phosphoric acid. This mist is collected as 85 per cent acid by a Cottrell electrostatic precipitator made of graphite to resist the action of HF. This acid contains some calcium salts and other impurities which were drawn from the furnace as dust.

This impure acid is put into large lead-lined tanks and live steam blown into it until it is heated nearly to the boiling point. This dilutes it to 80 to 75 per cent. Sufficient sulfuric acid is added to precipitate the calcium as calcium sulfate, and to leave 0.2 to 0.3 per cent SO_2 in solution. This last is quite important, as without this slight excess of sulfuric acid, phosphoric acid of this strength cannot be handled in lead. When a small amount of sulfuric acid is present, a dense scale of lead sulfate, insoluble in phosphoric acid, forms and protects the lead from further attack. After the acid treatment, finely powdered silica is added to combine with the hydrofluoric acid, and then hydrogen sulfide is blown into the acid until it is saturated. The excess silica, suspended matter, and the precipitate of calcium sulfate and arsenic trisulfide are removed by passing the acid through sand filters.

The electric-furnace process described above may be thought of as involving three fundamental steps: (1) Reduction of the phosphate rock with liberation of elemental phosphorus; (2)

burning the phosphorus to P_2O_5 ; and (3) converting the P_2O_5 to phosphoric acid by the addition of water and the subsequent collection of this acid. In the process described in previous paragraphs, all these three steps take place consecutively. It is, however, possible to interrupt the above process between any two of the steps.

At the present time a considerable amount of the phosphoric acid made in the United States is made by operating an electric furnace to reduce phosphate rock to phosphorus much as described above.⁽¹⁶⁾ The only difference is that the top of the furnace is closed, so that no air is drawn into the charge in the zones where phosphorus exists as elemental phosphorus. The gas containing phosphorus vapor is cooled. The phosphorus condensed is liquid yellow phosphorus, which can be stored under water in tanks provided with steam coils and can be shipped in ordinary tank cars. There is small use for phosphorus as such and, therefore, most of this phosphorus is ultimately burned to P_2O_5 and hydrated to H_3PO_4 . The deposits of phosphate rock are not often near areas that consume phosphoric acid, and it is cheaper to ship the phosphorus than it would be to ship phosphate rock to acid-consuming points or to ship phosphoric acid from the areas where phosphate rock occurs.

The phosphorus is pumped as a liquid through a spray-burner into a tower lined with acid-proof brick. Part of the air for the combustion is introduced in the spray nozzle, and part of it at the top of the tower. The phosphorus burns to P_2O_5 , the vapor is passed down the tower, and in the lower part of the tower is hydrated with a spray of steam or finely atomized water. The mist of phosphoric acid is then recovered by scrubbing in packed towers⁽¹⁷⁾ or filters.

The phosphorus is so pure that very high strength and very pure acids may be made from it and, therefore, an elaborate system of purification is not necessary. This is the method used to prepare the very high-strength acids mentioned on page 127.

Blast Furnace Process.—Phosphoric acid is also made by carrying out reaction (32) in a *shaft furnace*,⁽¹⁸⁾ which in appearance is very similar to an iron blast furnace. Phosphate rock, quartz, and carbon are briquetted, and the briquets charged to the top of the furnace. Preheated air is blown in at the bosh of the fur-

nace. Slag and some ferrophosphorus are tapped from the base of the furnace, and from the top of the shaft there is withdrawn a stream of gas containing phosphorus, carbon monoxide, and nitrogen. Most of this gas is burned in hot-blast stoves, very similar to the hot-blast stoves used in iron blast-furnace practice. These stoves furnish the preheat for the blast. The burned gas is cooled, sprayed with water, and the acid fog collected in a Cottrell precipitator. A portion of the gas, instead of being burned in the hot-blast stoves, may be sent to a condenser where the phosphorus is condensed. There is at present only one such installation in the United States.

References

- (1) CUMMING, A. C., "Hydrochloric Acid and Salt Cake," Gurney and Jackson (1923).
- (2) LAURY, N. A., "Hydrochloric Acid and Sodium Sulfate," Chemical Catalog Company (1927).
- (3) ZEISBERG, F. C., *Chem. Met. Eng.*, **32**, 326-327 (1925).
- (4) BAKER, E. M., and WIEGAND, J. H., *Trans. Am. Inst. Chem. Eng.*, **35**, 237-254 (1939).
- (5) PERRY, J. H., "Chemical Engineers' Handbook," Sect. X, McGraw-Hill Book Company, Inc. (1941).
- (6) TYLER, S. L., *Trans. Am. Inst. Chem. Eng.*, **17**, 75-79 (1926).
- (7) FRITZ, H. E., and WITHROW, J. R., *Trans. Am. Inst. Chem. Eng.*, **15** (I), 217-229 (1924).
- (8) HUNTER, F. L., *Ind. Eng. Chem.*, **30**, 1214-1219 (1938).
- (9) MECKSTROTH, J. T., *Chem. Met. Eng.*, **26**, 77-79 (1922).
- (10) LARISON, E. L., *Ind. Eng. Chem.*, **21**, 1172-1175 (1929).
- (11) JACOB, K. D., *Ind. Eng. Chem.*, **23**, 14-21 (1931).
- (12) WEBER, W. C., *Chem. Met. Eng.*, **39**, 659-662 (1932).
- (13) MONTGOMERY, G. L., *Chem. Met. Eng.*, **32**, 547-551 (1925).
- (14) KLUGH, B. G., *Chem. Met. Eng.*, **36**, 666-669 (1929).
- (15) KLUGH, B. G., *Ind. Eng. Chem.*, **24**, 371-374 (1932).
- (16) KIRKPATRICK, S. D., *Chem. Met. Eng.*, **44**, 644-650 (1937).
- (17) BASKERVILL, W. H., *Trans. Am. Inst. Chem. Eng.*, **37**, 79-94 (1941).
- (18) EASTERWOOD, H. W., *Chem. Met. Eng.*, **40**, 283-287 (1933).

Problems

1. A hydrogen chloride cooler is built of silica S-bends six inches in diameter. The plant is processing 10 tons of NaCl per day, with 95 per cent conversion to HCl; the furnace gas is 60 per cent HCl (remainder air) and leaves at 500°F., and may be assumed to have a mean specific heat of 7 B.t.u. per pound mol per degree Fahrenheit. This gas must be cooled to 125°F. with water entering at 70°F. and leaving at 100°F. The area of the cooler is 115 square feet. Calculate the coefficient of heat transfer, in B.t.u. per square foot per degree Fahrenheit per hour.

If the maximum permissible gas velocity is 10 feet per second at the inlet, how many stacks are required?

2. Ten tons of 22°Bé. hydrochloric acid are to be made per day by absorbing a gas containing 25 per cent HCl. The exit gas contains 0.2 per cent HCl. Calculate the quantities of water and gas used.

3. How much heat must be dissipated in the absorption apparatus of Problem 2 to maintain the temperature of the liquid at 20°C.?

4. A plant is to produce 120 tons per day of H_3PO_4 as a solution containing 22 per cent P_2O_5 , by treating pebble phosphate with sulfuric acid. The pebble phosphate contains 75 per cent $Ca_3(PO_4)_2$. This is treated with 120 per cent of the 60°Bé. H_2SO_4 theoretically required for the $Ca_3(PO_4)_2$. Ninety-five per cent of the phosphate is converted to H_3PO_4 , and 97 per cent of this acid is recovered in the leaching process.

- a. How many tons of pebble phosphate are treated per day?
- b. How many tons of 60°Bé. H_2SO_4 are used per day?
- c. If the leached solids contain 0.2 tons of water per ton of rock treated, how many tons of water may be used per day for washing the precipitate?
- d. If the phosphoric acid is to be concentrated to 45 per cent H_3PO_4 , how many tons of water must be evaporated per day?

CHAPTER VI

SODIUM CARBONATE

There is no one alkaline reagent that is used industrially to the exclusion of others. The field is shared by three materials: sodium carbonate, sodium hydroxide, and lime. This is in marked contrast to the situation in respect to acids, where sulfuric acid is so much more important than any of the other commercial acids that it easily dominates the field. The other acids are used only where they are made necessary by some other consideration, such as the presence of their specific anions. Although none of the alkaline reagents may be said to dominate the field, yet because of its relatively low cost,* sodium carbonate is much more widely used than caustic. Lime is still cheaper, but many calcium salts are insoluble; and frequently this is a disadvantage. Until comparatively recently, the manufacture of sodium carbonate was a necessary step in the manufacture of caustic soda. Much caustic soda is now made directly from salt by electrolysis, but a considerable amount of soda is still used for caustic manufacture.

Production and Distribution.—The estimated consumption of sodium carbonate in 1940 was 3,157,000 tons. This was distributed as follows:

	Per cent
Chemicals.....	47.2
Glass manufacture.....	28.6
Soap.....	5.8
Modified sodas.....	4.3
Pulp and paper.....	3.5
Textiles.....	1.4
Water softening.....	1.0
Petroleum refining.....	0.4
Exports.....	1.9
Miscellaneous.....	5.9

* For many years sodium carbonate has been quoted at about 1.0 cent, caustic soda 2.3 to 3.0 cents, and lime from 0.5 to 1.0 cent per pound.

Grades.—Both sodium carbonate and sodium hydroxide are ordinarily marketed on a peculiar basis, known as the New York and Liverpool test. This test was supposed to give the per cent Na_2O , but the calculations were based on atomic weights that are now known to be incorrect. In spite of this, the test is still used because the trade is accustomed to it. Sodium carbonate is actually 58.5 per cent Na_2O , but by the New York and Liverpool test it is 60.4 per cent Na_2O . Consequently, carbonate which is 58 per cent by the New York and Liverpool test is actually 96 per cent Na_2CO_3 .

Soda ash is the trade name for anhydrous sodium carbonate. It is ordinarily sold as 58 per cent light ash. Sodium chloride and sodium sulfate are the principal impurities. Light soda ash is powdery and inclined to dust; and consequently for some purposes a dense ash is demanded, which is made by calcining a light ash. Sometimes a soda ash of less than 58 per cent is desired, and in such cases it is reduced by mixing with sodium chloride or sodium sulfate.

Sodium bicarbonate comes on the market ordinarily in one grade, which is a nearly pure form of NaHCO_3 .

Sal soda is the common name for $\text{Na}_2\text{CO}_3 \cdot 10\text{H}_2\text{O}$. It is produced by crystallizing solutions of sodium carbonate at temperatures below 35°C .

Sodium Carbonate Monohydrate.—At temperatures above 35°C . the form which crystallizes from solution is $\text{Na}_2\text{CO}_3 \cdot \text{H}_2\text{O}$. There is a small demand for this monohydrate in washing powders and laundry compounds.

Modified Sodas.—In many cleansing preparations an alkali less strong than sodium carbonate is desired. For this purpose, various mixtures of sodium carbonate and sodium bicarbonate are sold as modified sodas. The mixtures vary according to the purpose for which they are to be used. One double salt, $\text{Na}_2\text{CO}_3 \cdot \text{NaHCO}_3 \cdot 2\text{H}_2\text{O}$ is manufactured and marketed as *sesquicarbonate*. Where cleansing agents of a greater alkalinity than sodium carbonate are desired, various mixtures of sodium carbonate and sodium hydroxide are marketed as causticized ash.

Development of the Soda Processes.—The original source of sodium carbonate was natural deposits. Until the time of the French Revolution the world's supply of alkali was either natural soda, or potash made from wood ashes. In 1775, a prize was

offered by the French Academy (2,400 livres) for a process for converting salt into soda. The prize was claimed by Nicolas LeBlanc in 1790, but he never received the grant and the original works were seized by the Revolutionary Committee. The LeBlanc process developed rapidly, and during the nineteenth century was the principal source of supply of alkali for the world. In 1860, Ernst Solvay attempted to operate a plant by what is now known as the Solvay process. It was 1866, however, before it was commercially successful. The Solvay process grew rapidly, and proved so superior to the LeBlanc process that today all of the soda made in the world is made by the Solvay process. No Leblanc plants have ever been built in the United States.

LEBLANC PROCESS

Figure 38 is a flow sheet of the LeBlanc process.⁽¹⁾ Sulfuric acid and salt were charged into an ordinary salt-cake furnace (Fig. 30, p. 113), producing hydrogen chloride and sodium sulfate. At first the hydrogen chloride was allowed to escape into the air, but as the industry developed this became such a nuisance that the gas was absorbed and recovered as hydrochloric acid. The sodium sulfate, with coke and limestone, was charged into a reverberatory furnace known as the black-ash furnace. In this furnace approximately the following reactions took place:

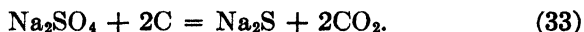

The product was not fused, and was withdrawn as a porous solid mass. This black ash was leached with water at low temperatures, and so far as possible without access of air. The solution contained sodium carbonate, sodium sulfide, sodium hydroxide, and many impurities. The liquor was then showered down a tower in countercurrent to the gas from the black-ash furnace. This displaced some hydrogen sulfide, and also converted sodium hydroxide, aluminate, silicate, and cyanate to sodium carbonate. The carbonated liquor was concentrated in an open pan set at the rear of the black-ash furnace until the solution was strong enough to precipitate a crop of sal soda crystals on cooling: These were either calcined to crude soda ash or dissolved, purified, recrystallized, and calcined to yield a high-grade product. The red liquor which remained after crystallizing the first crop of soda

was purified to remove iron and cyanogen compounds, causticized with lime, and evaporated to produce solid sodium hydroxide.

The residue or mud from the extraction tanks consisted largely of calcium sulfide. Originally, this was merely sent to dumps, but the odor of hydrogen sulfide, and the calcium polysulfides which leached from these dumps and contaminated the streams, were so offensive that it became necessary to dispose of the cal-

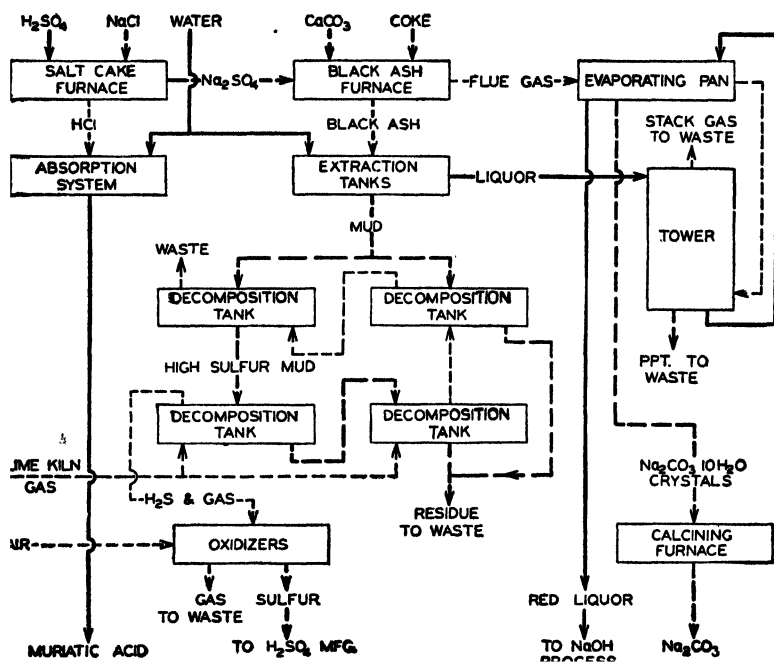

FIG. 38.—Flow sheet of LeBlanc process.

cium sulfide in some other way. To do this, the mud was suspended in water and treated in a series of closed tanks, into the first of which limekiln gas was passed. Carbon dioxide precipitated calcium carbonate and liberated hydrogen sulfide.



The precipitate of calcium carbonate, carbon, and other insoluble materials was now clean enough to be discarded. The gas, however, was not rich enough in hydrogen sulfide to be suitable for recovery, and therefore was passed into another tank containing

suspended mud where hydrogen sulfide was absorbed to form calcium acid sulfide.

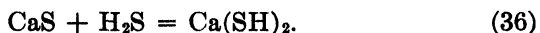

This solution of acid sulfides was treated with fresh limekiln gas which liberated a gas rich in hydrogen sulfide.

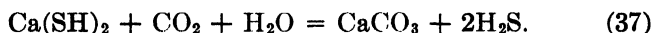

The residue from this treatment was sent back to the original absorbers to be treated according to equation (35). The hydrogen sulfide was too large in amount to waste, and was therefore burned in a special kiln with a limited supply of air in the presence of hydrated iron oxide as a catalyst. The reaction was so controlled that the hydrogen sulfide was burned according to the reaction

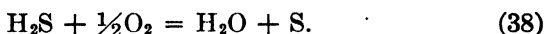

This sulfur was sublimed, collected, and sent back to the sulfuric acid plant.

It is evident from the above description that the process was cumbersome, very complicated, and involved the expenditure of much labor and fuel. In its later days considerable effort was made to decrease the amount of labor required, but these efforts came too late to be effective in the face of competition from the Solvay process. Through many parts of the process, the materials handled were solids and at that time this made much hand labor unavoidable. Although the Solvay process flow-sheet may appear as complicated as the LeBlanc, the Solvay process handles solutions and gases almost entirely; and since these can be handled in pipe lines, by pumps and compressors, the labor required is a minimum. The fuel cost in the LeBlanc process could not be reduced and always remained as its most serious drawback.

SOLVAY PROCESS

The equation that represents the principal reaction in the Solvay process is



Ernst Solvay was not the first to realize that sodium carbonate could be produced by this reaction; but he was the first to work out conditions necessary for satisfactory yields, and to develop

the process on a commercial scale. Solvay obtained patents on his process, organized the Solvay Process Company of Belgium, and retained control of the process throughout the world during his lifetime. Within recent years, the American Solvay Process Company has severed its connections with the parent company, and is now an entirely independent concern. The general outline of the Solvay process is well known. Its successful operation depends on close correlation and control of operating conditions, and on almost complete recovery of ammonia. The details of operation, the exact sequence of the steps, the design of the apparatus, and the conditions to be maintained were long kept secret. What is said here will be correct in its major phases; but some statements may or may not represent present practice. Operating conditions have been worked out independently by other companies, so that there are in the United States four or five plants, not connected with the Solvay organization, making soda by the Solvay process.

Flow Sheet.—Figure 39 is a flow sheet representing the Solvay process in a general way.⁽²⁾ Brine is derived from beds of rock salt by pumping down water as discussed in Chap. II, and is nearly saturated at about 60°F. It will also contain as impurities calcium, magnesium, and traces of iron. This brine goes first to two small absorbing towers in parallel, where it picks up a certain amount of ammonia; and then to the brine purifier, where it is used to recover the residual ammonia in the tower gases, and at the same time it absorbs some carbon dioxide. It then passes to the second absorber where it dissolves additional ammonia. The combination of the alkalinity due to the ammonia, and carbonate ions due to the absorption of CO₂, precipitates the calcium, magnesium, and iron present as impurities in the brine. From this absorber the brine goes to settlers where the precipitate is removed; and the clarified brine, after cooling, goes to the first absorber, where further absorption of ammonia brings it to the desired concentration. The brine, after cooling again, goes to the towers for the formation and precipitation of sodium bicarbonate.

These are two very large towers in series. In the first, or carbonating tower, scrubbed limekiln gas is introduced at the bottom, and the CO₂ absorbed from this forms ammonium carbonate with the dissolved ammonia. The waste gas from the top of this

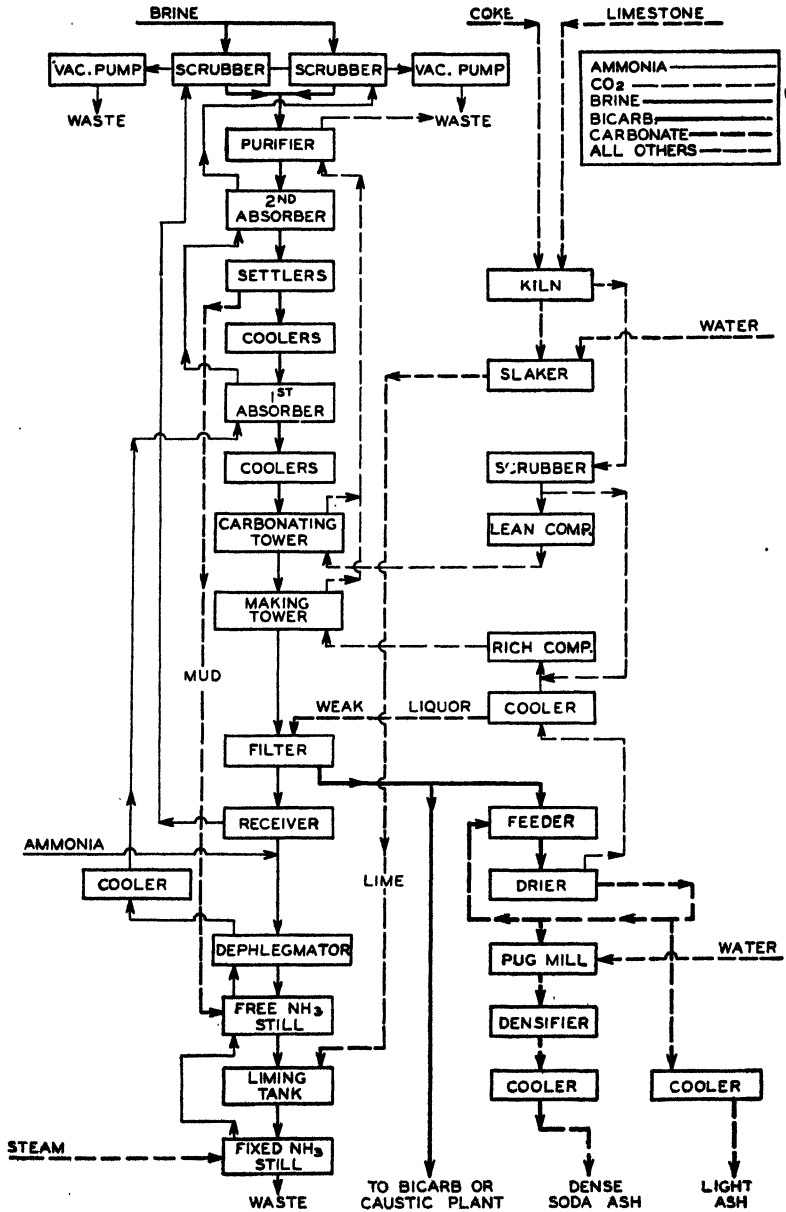

Fig. 39.—Flow sheet of Solvay process.

tower is used in the raw brine purifiers previously mentioned. The carbonated brine next goes to the second, or making, tower where it is treated with a gas high in CO_2 . It is in this tower that the principal reaction of the Solvay process takes place. The primary product of the reaction, sodium bicarbonate, comes out of the bottom of the tower as a slurry. The gas leaving this tower (like the gas from the carbonating tower) is used in the brine purification.

The slurry coming from the bottom of the making tower is saturated with CO_2 and contains considerable ammonium bicarbonate. It is filtered on a rotary continuous vacuum filter, but one result of the vacuum is to liberate much ammonia and CO_2 . This rich ammonia gas is sent to one of the primary brine purifiers. The filtrate, containing sodium and ammonium bicarbonates and chlorides, must be treated to recover all of the ammonia and as much of the carbon dioxide as possible. This is accomplished in large distillation columns. The filtrate first goes through closed coils in a dephlegmator section at the top of the tower. It then passes down a section containing bubble caps, where "free" ammonia and some carbon dioxide are removed. The liquid is then withdrawn from the tower and mixed with milk of lime to decompose the ammonium chloride. It is then returned to the tower, and the "fixed" ammonia thus liberated is distilled off by blowing steam into the bottom of the tower. The effluent from the base of the tower is essentially a solution of sodium and calcium chlorides, practically free from ammonia. Because it contains a considerable precipitate of calcium carbonate, it goes first to large settling ponds where this lime mud settles. Some of the solution may be filtered and worked up for calcium chloride and other products, but the bulk of it is wasted.

The moist precipitate of sodium bicarbonate removed from the filter goes first to a drier or calciner. This drier is a closed unit and, therefore, must have some form of automatic feeder. In this drier, not only is the superficial moisture (together with its dissolved ammonia) evaporated from the precipitate, but the sodium bicarbonate is converted, by the liberation of CO_2 , into the normal carbonate. The gas coming from this drier is very rich in CO_2 and, after cooling, is mixed with weak gas from the limekiln to make the strong gas blown into the making tower. In cooling this gas coming from the drier, moisture is condensed,

and this will contain a little ammonia, will be saturated with CO_2 , and will contain some alkali because of dust from the drier. This dilute solution is used as wash water on the bicarbonate filters.

The product of the drying and calcining operation is the light soda ash of commerce. A part of it may be run through a cooler and then becomes the finished product. The moist bicarbonate precipitate has a strong tendency to agglomerate in the drying process, and this tendency is diminished by returning a considerable amount of light soda ash to the drier feed. If a denser ash is desired, the light soda ash from the calciner is moistened with water in a pug mill, which results in the formation of some crystals of $\text{Na}_2\text{CO}_3 \cdot \text{H}_2\text{O}$. If this then goes to a second drier, the monohydrate crystals are dehydrated but do not lose their shape, and thus give a denser soda ash which, on cooling, is the dense ash of commerce.

Any sodium bicarbonate to be sold as such is obtained by taking the bicarbonate from the filter, and recrystallizing it to make a purer NaHCO_3 . In most plants operating the Solvay process, a certain amount of sodium hydroxide is made, and this is produced from another fraction of the bicarbonate by methods to be mentioned in the next chapter.

Operation of the Solvay Process.—Most of the operations in the Solvay process involve reactions between gases and liquids. This holds true for the gas scrubbers, the brine purifier, the apparatus in which the brine is saturated with ammonia, the carbonating and making towers, and the ammonia still. Consequently, the design of Solvay equipment largely centers around the design of gas-liquid contact apparatus.

In practically all of these units, either a precipitate is formed, or there may be a deposition of scale. Consequently, packed towers are out of the question. If bubble-cap construction is used, the bubble caps must be very large, and passages for both liquid and gas must be ample to prevent clogging with precipitate. The usual design of all of this apparatus is basically similar to that of the carbonating tower, which is shown in Fig. 40. There is only a single bubble cap per section, and this cap becomes a shallow curved disk of cast iron, supported above a tapered base plate which has a large opening for gas in the center. The edges of the openings are serrated to subdivide the gas as

much as possible; although with such construction as this, the contact between gas and liquid is not so intimate as could be desired.

In the first scrubbers which the raw brine enters, a relatively small amount of both ammonia and CO_2 is to be dissolved and, consequently, these towers are not high and are relatively simple. There is no great evolution of heat in them. When the two

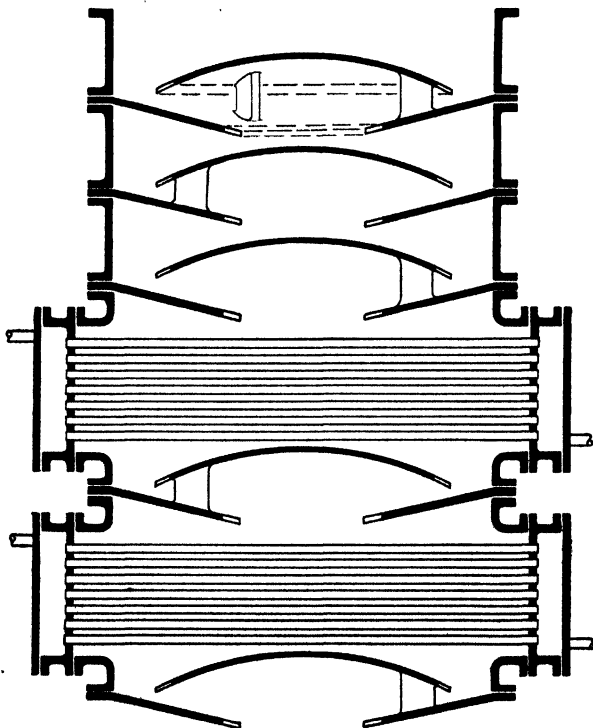

FIG. 40.—Solvay-tower construction.

ammonia absorbers are reached, there is a relatively large amount of absorption. Consequently, these towers are taller. The absorption of ammonia in the brine liberates heat, and because an increase in the temperature of the brine would increase the partial pressure of ammonia (and, therefore, decrease the strength of ammonia solution that could be made) it is necessary that these absorbing towers have cooling sections, such as are shown in Fig. 40. By the time the brine has passed through the second

absorber, precipitation of the impurities has been accomplished, and these are removed in the settlers, which are large cone-bottomed steel tanks with slow-moving stirrers. The small amount of mud withdrawn from these is sent to the ammonia tower for recovery.

To reduce the temperature of the brine as far as possible and thus decrease the vapor pressure of ammonia, cooling coils are introduced as shown in the flow sheet. These consist of a large number of horizontal runs of pipe with water showered down over them. The brine leaving the first absorber contains about 80 grams of NH_3 and 260 grams of NaCl per litre.

The carbonating tower is made up of the units shown in Fig. 40, and is about 75 feet high. The upper half of the tower is made up of simple bubble-cap sections, and the lower half of the tower contains cooling sections also. The great height of the tower is necessary because of the poor contact between gas and liquid, and the consequent necessity of having many such contacts in order to approach equilibrium. It has a second advantage, however. Unlike most gas-liquid contact apparatus, these towers are run "flooded," that is, in such a way that they are filled with liquid up to the feed inlet. The column contains a few sections above this point to remove entrained liquid and take care of surges. This flooding puts a considerable hydrostatic head on the bottom of the tower. The gas must be compressed to this pressure before it enters the tower, and this increases the partial pressure of the CO_2 and, consequently, its solubility. The construction of the carbonating and making towers is the same. The plant usually has a number of these towers so connected that any of them can be used either as the making tower or the carbonating tower, with one always shut down for cleaning. Bicarbonate scale forms in the making tower, and it can be largely removed by using a making tower as a carbonating tower, thus dissolving the scale in the feed brine.

Control of conditions in the making tower is extremely important. It is necessary that the liquid leaving these towers at the bottom be as cold as possible. This is usually 20 to 22°C. The solubility of sodium bicarbonate decreases rapidly with temperature, and this cooling is necessary to get reasonable yield; both because sodium bicarbonate in solution is lost, and sodium bicarbonate in solution affects the equilibrium of equation (39)

unfavorably. If the whole tower were cooled, however, the bicarbonate precipitate would be fine and unfilterable. The temperature at the top of the tower is not high, due to the cool entering brine. By allowing the temperature to rise in the upper third of the tower, crystallization of sodium bicarbonate is avoided. As the liquid descends through the tower and becomes more nearly saturated with CO_2 and cooler, precipitation of sodium bicarbonate starts. By starting a few bicarbonate nuclei and precipitating slowly, the additional material will largely grow on the existing nuclei, making good filterable crystals. If it were all precipitated at once, too many nuclei would be formed and the crystals would be too fine. A high temperature in the top of the making tower is undesirable, because this would result in excessive volatilization of ammonia, decreasing the amount of ammonia in the brine going down the tower, and unfavorably affecting the equilibrium of equation (39). The usual temperature gradient in such a tower starts at 20 to 22°C. at the bottom, becomes as high as 55°C. 50 feet up, and at the top of a 75-foot tower falls to about 25°C.

The effluent from the base of the making tower (called *draw liquor*) contains about 0.75 mol of precipitated sodium bicarbonate per mol of sodium chloride entering the system. The composition of the clear solutions is:

NH_4Cl	180–200 grams per liter.
NH_4HCO_3	75– 90,
NaCl	70– 80,
NaHCO_3	6– 8,
CO_2	35– 40,
Sulfide.....	Trace.

The bicarbonate crystals are filtered on a rotary continuous vacuum filter of a type similar to those in general use in other industries. Since the filtrate is withdrawn under vacuum, there must be a filtrate receiver, and from this receiver excess ammonia and carbon dioxide escape from the mother liquor and are absorbed in the incoming brine.

The drier or calciner for the bicarbonate is a horizontal rotating steel cylinder, with both ends closed so that the CO_2 evolved can be collected in as pure a state as possible. The drier is set in a brick furnace, so fired that the hot gases pass around the outside

of the cylinder. The coolers are simply open rotating horizontal steel cylinders, and the heat is dissipated partly by radiation from the shell and partly by a current of air that passes through the coolers.

The ammonia still is a tall bubble-cap column similar in construction to the carbonating tower. Any ammonia present as carbonate or bicarbonate can be driven off by steam in the upper parts of the tower. Sodium bicarbonate is largely converted to the normal carbonate with the evolution of CO_2 , which passes off with the ammonia. The temperature of the exit gas may not be below 55°C ., or there will be danger of stoppages due to the formation of solid $(\text{NH}_4)_2\text{CO}_3$. To recover the ammonia that is present as ammonium chloride, the solution is limed and returned to the still. This lower part of the still is sometimes called the "fixed" ammonia still, as differentiated from the "free" ammonia section above it. Heat to the still is entirely supplied by steam, which is blown directly into the solution at the bottom of the tower. If the lime were added to the filtered draw liquor, rather than after the decomposition of the bicarbonates and ammonium carbonate, the consumption of lime would be greatly increased, excessive amounts of calcium carbonate would be formed, and less carbon dioxide would be returned to the process.

The vapor coming from the top of the still is a mixture of ammonia and water vapor with some CO_2 . By partial cooling, much of the water can be condensed, and this cooling is accomplished in the dephlegmator section by the cool incoming filtrate, and in a final condenser with water cooling. It is not feasible to cool too far, because the ammonia gas would dissolve in the cool condensate. Consequently, the vapor leaving the top of the still contains appreciable quantities of water vapor, and this therefore dilutes the brine somewhat when this vapor is absorbed in the brine.

It is necessary that the losses of ammonia from the system be kept as low as possible. In the past the source of ammonia for make-up has always been from coke ovens, and crude ammonia liquor is sometimes added to the filtrate on its way to the ammonia still. The same purpose can be accomplished by adding a solution of ammonium sulfate or aqua ammonia at the same point. The total loss of ammonia at present is 0.35 to 0.5 per cent of the final soda made.

Ammonium chloride is sometimes made from filtrate by diverting a small fraction of it and concentrating it in evaporators. As the concentration of ammonium salts increases, the solubility of sodium chloride decreases, so that sodium chloride is thrown out in the evaporators. A crop of ammonium chloride is obtained by cooling the mother liquors, and can be purified by recrystallization. Ammonia so withdrawn from the system increases the make-up, but the ammonium chloride is more valuable than the equivalent amount of crude ammonia or ammonium sulfate.

References

- (1) THORPE, "Dictionary of Applied Chemistry," VI, 160-174, Longmans, Green & Co. (1926).
- (2) HOU, T.-P., "Manufacture of Soda," The Chemical Catalog Company, Inc. (1933).

Problems

1. A LeBlanc plant produces 25 tons per day of Na_2CO_3 from NaCl and $66^\circ\text{Bé. H}_2\text{SO}_4$. The salt cake contains 0.3 per cent H_2SO_4 , and negligible NaCl . How much salt and 66°Bé. sulfuric acid are required per day?

What weight of HCl and H_2S gases must be disposed of each day?

If the HCl is absorbed as 20°Bé. acid and the H_2S is burned to sulfur, what weights of acid and sulfur are produced per day?

2. An ammonia soda plant produces soda ash analyzing 99.5 per cent Na_2CO_3 , 0.5 per cent $\text{NaCl} + \text{H}_2\text{O}$. The conversion of NaCl into precipitated NaHCO_3 is 75 per cent complete. The amount of salt so converted is 37 tons per day.

a. How much salt is in the brine used?

b. If this brine is saturated at 68°F. , what is its volume?

c. How much salt is unused?

d. How much soda ash is produced?

e. How much wet bicarbonate is charged to the calciner, if its water content is 0.3 pound water per pound of NaHCO_3 ?

f. If the titer of *fixed* ammonia in the feed to the ammonia still is 68, what is the volume of this feed in gallons per hour?

Titer is cubic centimeters of normal acid solution required to neutralize the ammonia in 20 cubic centimeters of sample.

3. For the production of the soda specified in Problem 2, how much carbon dioxide is present in the finished soda ash? If the entire amount of this carbon dioxide is to be supplied from the calcined limestone (95 per cent CaCO_3), how much limestone will be required per day? Is the lime simultaneously obtained sufficient for the regeneration of the fixed ammonia, or is it in excess, or is there a deficiency?

4. In the plant of Problem 2 the limekiln is operated with coke equivalent to 0.10 pound carbon per pound of limestone charged. The exit gases from

the system carry CO_2 equal to 3 per cent of the CO_2 present in the recovered NaHCO_3 , and no CO_2 is lost from the ammonia still nor from the bicarbonate calciner. If there is assumed 100 per cent utilization of $\text{Ca}(\text{OH})_2$ in the liberation of fixed ammonia, is the lime obtained simultaneously sufficient for the regeneration of the fixed ammonia, or is there an excess, or is there a deficiency? If an excess or a deficiency, state how much.

CHAPTER VII

CAUSTIC SODA AND CHLORINE

In Chap. VI it was pointed out that there are three materials that find wide industrial use as alkaline reagents: sodium carbonate, sodium hydroxide, and lime. Sodium hydroxide has several important advantages over the other two. Its high solubility makes it possible to secure strongly alkaline solutions; and, unlike lime and sodium carbonate, it does not form insoluble compounds. Sodium hydroxide is more than twice as expensive as sodium carbonate, and therefore where either may be used, the latter is chosen. Sodium carbonate has a further advantage in that it is much easier to handle. If a low concentration of hydroxyl ions is satisfactory, and if the presence of calcium is not objectionable, since lime is the cheapest it is, therefore, the most desirable reagent for commercial purposes. The other two alkalies commonly used in laboratory work—ammonium hydroxide and potassium hydroxide—are even more expensive than sodium hydroxide so that they are only used where there is a specific need for their particular cations.

Production and Distribution.—In 1940, *Chemical and Metallurgical Engineering* estimated that 1,095,000 tons of caustic soda were made in the United States. This was distributed approximately as follows:

TABLE XXI.—DISTRIBUTION OF CAUSTIC SODA

	Per cent
Rayon.....	21.0
Miscellaneous chemicals.....	20.0
Exports.....	9.6
Soap.....	8.7
Petroleum refining.....	8.0
Pulp and paper.....	4.6
Household lye.....	4.4
Textile finishing.....	4.4
Rubber reclaiming.....	1.8
Vegetable-oil refining.....	1.5
Miscellaneous.....	16.0

Caustic soda is often sold on the basis of the New York and Liverpool test mentioned in Chap. VI. The standard formerly was 76 per cent Na_2O . This corresponds to 95 per cent actual NaOH . As a matter of fact, practically all manufacturers of caustic soda furnish material that contains 98 per cent NaOH or better, and at present this material is usually sold on its actual NaOH content. Electrolytic caustic usually contains 1.5 to 2 per cent of sodium chloride, and this is undesirable in the manufacture of rayon. The enormous growth of the rayon industry in recent years has made this an attractive market, and many manufacturers are making efforts to produce extremely high-grade caustic for this purpose. There is caustic actually available that will contain 99.5 per cent NaOH or better.

Caustic soda is usually shipped in steel drums that contain about 700 pounds of fused NaOH . For some purposes where the very disagreeable labor of opening these drums and handling the cake is undesirable, flake caustic is supplied. This is higher in price and there is less weight in a package, but for many purposes its convenience offsets this small differential.

CHEMICAL CAUSTIC

Much sodium hydroxide is made by reaction between lime and soda ash according to the equation



This process is called the *chemical* process merely to distinguish it from the *electrolytic* process, which will be discussed later.^(1,2,3) Most chemical caustic is made at ammonia-soda plants. The flow sheet of Fig. 39 shows crude bicarbonate diverted to the caustic plant. In such a case, the bicarbonate is dissolved in water and converted to normal carbonate by steam in a tower. The resulting solution of Na_2CO_3 is used for the process of equation (40), and the CO_2 from the top of the tower is made into dry ice. In other cases soda ash is the starting material for equation (40).

Flow Sheet.—Figure 41 shows a very much simplified flow sheet of the chemical caustic process. Lime is slaked, usually by the addition of a limited amount of water so as to produce dry $\text{Ca}(\text{OH})_2$. Soda ash and this dry slaked lime are then stirred into wash water returned from a later step in the process, and the

mixture is agitated from 1 to 3 hours to complete the reaction. The product of this reaction is a solution of sodium hydroxide with a precipitate of calcium carbonate suspended in it. The principal problem is to separate this calcium carbonate and to wash it free from caustic.

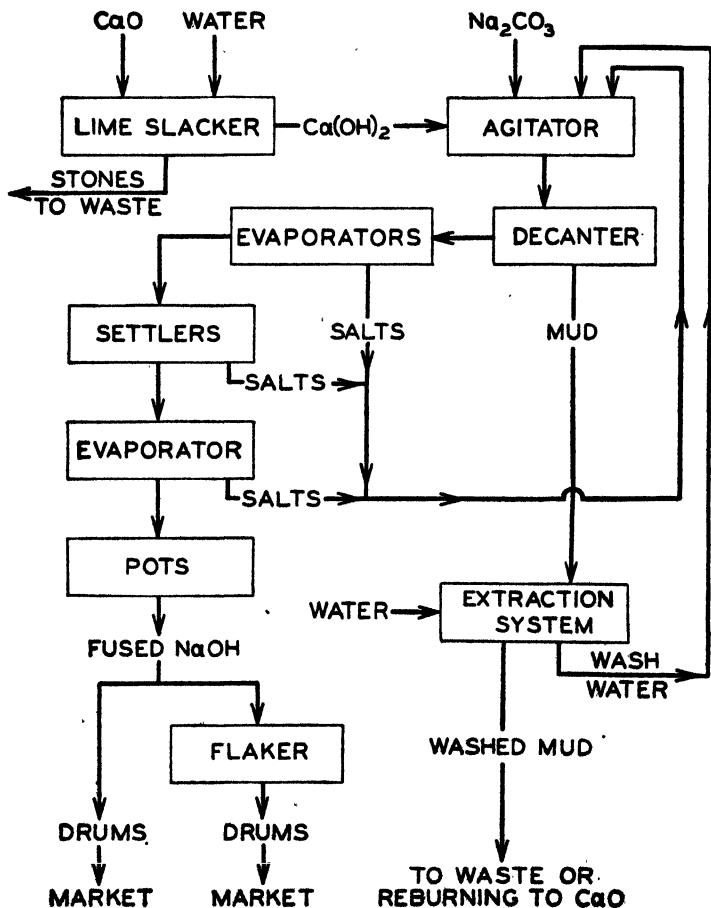

Fig. 41.—Flow sheet of manufacture of chemical caustic.

The reaction mixture usually goes to decanters of one type or another where an approximate separation is made, and most of the caustic is directly recovered as a clear solution. The mud that settles carries too much caustic to be discarded, and is put

through some system of washing. This wash water is returned to the first step in the process. The precipitate, practically free from caustic, is discarded or reburned. The particular methods by which this washing is accomplished will be discussed in detail later.

The causticizing process yields a solution of approximately 10 per cent NaOH from the settling system. In case the product desired is a solution of high concentration, or fused caustic, the 10 per cent solution goes to multiple-effect evaporators where it is concentrated to approximately 50 per cent, although practice in this respect varies greatly. This increase in concentration separates small amounts of sodium carbonate, sodium chloride, and sodium sulfate; the first representing unconverted material, the other two, impurities in the original soda ash. In the earlier stages of concentration, these separate from the dilute solutions as crystals large enough to be removed from the evaporator by ordinary methods. The increased viscosity of the more concentrated solutions causes the separation of very fine material that does not settle readily. Consequently, after leaving the evaporator, the strong solution may be stored for some time to permit this fine material to settle through the viscous solution. After settling, the solution is further concentrated in single-effect evaporators to densities ranging from 50 to 75 per cent, according to the purpose for which the solution is to be used. The final evaporation to fused anhydrous caustic is performed in cast-iron pots heated by direct fire. The product of these pots is either pumped into drums, where it solidifies to form the ordinary fused caustic, or it may be sent to a flaker where it is chilled to form flake caustic, which is packed in drums.

Chemical Theory.—In causticizing soda ash by the reaction of equation (40) some solid calcium hydroxide and solid calcium carbonate are always present. Since these are the only solid phases present in the temperature range ordinarily employed,* it follows that equilibrium between them determines the equilibrium in the reaction. At equilibrium, the ratio of the concentrations of hydroxyl and carbonate ions are given by the ratio of the solubility-product equations

$$\frac{K_1}{K_2} = \frac{[\text{Ca}^{++}][\text{OH}^-]^2}{[\text{Ca}^{++}][\text{CO}_3^{--}]} \quad (41)$$

* Below 80°C. some complex insoluble salts may be formed.

From this

$$K = \frac{K_1}{K_2} = \frac{[\text{OH}^-]^2}{[\text{CO}_3^{2-}]} \quad (42)$$

The heat of reaction is practically zero. Hence the value of K , and therefore the conversion, are independent of temperature. The reaction is usually carried out at temperatures near the boiling point because of the greater speed of the reaction at higher temperatures. It is desirable to have the proportion of unconverted sodium carbonate as low as possible but it is also desirable to produce as strong a solution of sodium hydroxide as possible. Since the concentration of hydroxyl ions appears in equation (42) as the square, and the concentration of carbonate ions as the first power, it follows that the more dilute the solution, the larger will be the ratio of hydroxyl ions to carbonate ions at equilibrium. Therefore, the more dilute the solution, the more complete is the conversion. The balance between completeness of conversion on the one hand, and cost of evaporation on the other, is met in practice by producing a solution of about 11 to 12 per cent NaOH. A 10 per cent sodium carbonate solution gives about 96 to 97 per cent conversion; a 7 per cent solution, 98 to 99 per cent.⁽⁴⁾

Dorr Causticizing Plant.—Figure 42a shows the flow sheet of a Dorr system for causticizing.⁽³⁾ Soda ash, slacked lime, and wash water are introduced into the first agitator. A Dorr agitator (Fig. 42b) is a flat-bottomed tank with a hollow central shaft, carrying a set of arms at the bottom and another set of arms above the level of the liquid. At the bottom of the shaft, compressed air is introduced through a nozzle. This lifts liquid and precipitate up through the shaft, and discharges them into the upper set of arms, which are in the form of launders. These are provided with numerous openings on the under side, so that as they rotate they distribute the mixture over the whole cross-section of the tank. The arms at the bottom of the tank have scraper blades set at an angle, so that any precipitate that settles is scraped to the center and lifted by the air jet. Two or three of these agitators are usually placed in series at slightly different levels. Feed to the first agitator causes a corresponding amount of material to be displaced and to overflow from one agitator to another; so that the mixture is gradually advanced through the series and is subject to agitation during the whole of the time.

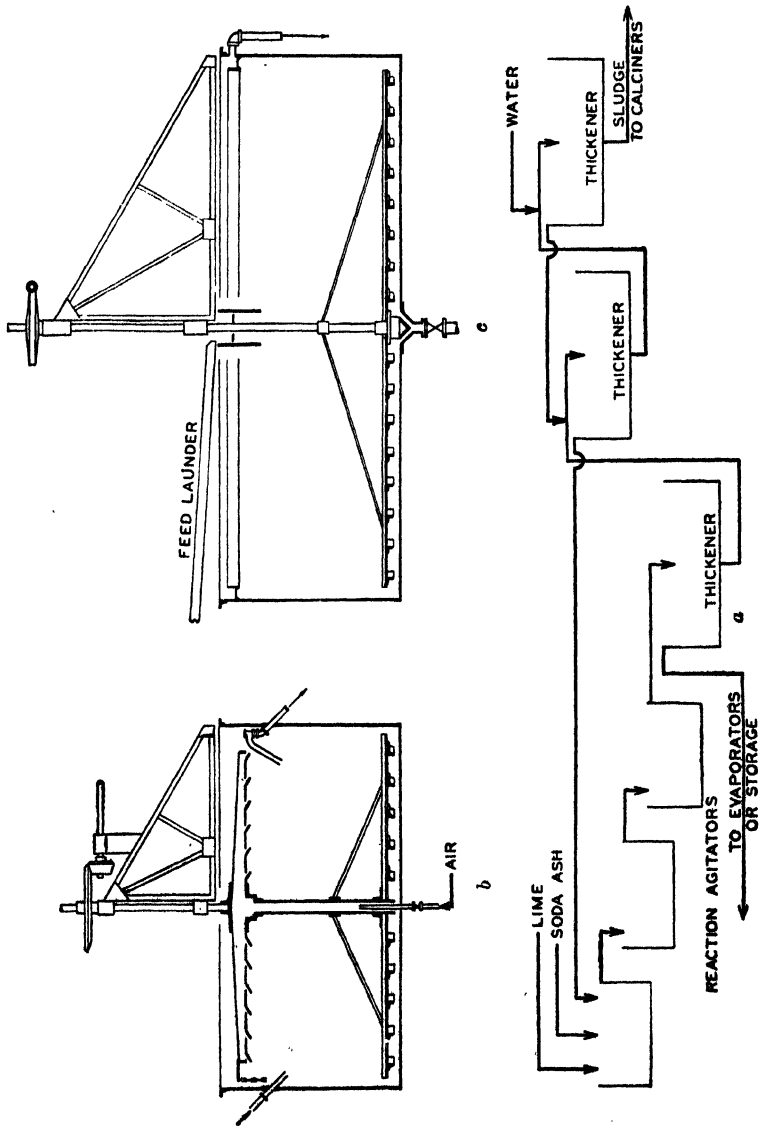

Fig. 42.—Dorr countercurrent extraction system.

The capacity of the agitators is so proportioned to the amount of feed that the reaction is complete at the end of the system.

The discharge from the final agitator goes to the first thickener. A thickener (Fig. 42c) is a flat-bottomed tank, of large cross-section compared to its depth, and having a central shaft carrying a series of arms at the bottom. These rotate so slowly that they do not agitate the liquid. They are provided with scrapers that rake the mud to a central outlet in the bottom of the tank, from which it is removed by a diaphragm pump. A launder around the upper edge of the tank receives the overflow of clear liquid. The mixture to be settled is fed to the thickener in the center at the top.

The rate at which a precipitate will settle through a still liquid depends on four factors. These are:

1. The size of the particles.
2. The shape of the particles.
3. The difference in density between the solid and the liquid in which it is suspended.
4. The viscosity of the liquid.

The cross-section of the thickener and the rate of feed are so proportioned that liquid flowing through the thickener will have a maximum upward velocity component enough less than the rate of settling of the finest particles in still liquid so that a clear overflow is obtained. Conditions of burning of lime, presence of impurities, rate of slaking, rate of mixing, and other factors greatly affect the characteristics of the precipitate, and therefore its rate of settling.⁽⁶⁾

At least three thickeners are used in series, as shown in Fig. 42a. The first thickener receives the agitator discharge, and produces a 11 to 12 per cent caustic solution, which is the product of this operation. Fresh water and mud from the second thickener are introduced as feed to the third thickener. The mud from this thickener is sufficiently free from caustic so that it may be discarded or reburned. The overflow from the third thickener and the mud from the first are mixed in the second, and the overflow from the second thickener is returned to the first agitator. Obviously there may be more than three thickeners in series.

The Dorr system is an adaptation of the Dorr agitator and thickener to the general process of countercurrent extraction. In any system of countercurrent extraction it is essential, first,

that the solid phase be intimately mixed with the liquid phase; and second, that time be allowed for the solute of the solid phase to come into equilibrium with the liquid phase. In this particular case the particles of precipitate may be considered to carry caustic only in the form of a layer of solution on their surface; and the problem, therefore, is to mix this surface layer with the bulk of the solution by diffusion and convection. Because of the fineness of the precipitate and its slow rate of settling, this extraction is more rapid than the settling of the solid; and therefore, the time of settling of the lime particles is the deciding factor in the design of this equipment.

Many of the data needed in the design of a countercurrent extraction system may be calculated by the method of material balances. In Fig. 42a let X , Y , and Z represent the concentration of caustic in the first, second, and third thickeners, respectively, expressed as tons of NaOH per ton of water. Assume that the plant is to produce 10 tons of NaOH per 24 hours and that X is to be 0.095. For 10 tons of NaOH there will be formed $10 \times 100\%$ or 12.5 tons of precipitate per day. It may be assumed that this mud can be discharged from the thickeners in the proportion of 1 part water to 1 part solids by weight. The discharge from the bottom of each thickener will therefore be 12.5 tons of precipitate, 12.5 tons of water, and the caustic dissolved in this water. The overflow from the first thickener carries 10 tons of caustic as a solution containing 0.095 tons per ton of water. This will, therefore, contain 10 tons of caustic and $10 \div 0.095$ or 105.3 tons of water. Since no material leaves the system except mud at one end and finished solution at the other, the total amount of water added to the third thickener must be equal to the water discarded in the strong solution and in mud, or $105.3 + 12.5 = 117.8$ tons of water per day. The caustic balance across each of the thickeners may now be written as follows:

First thickener, $117.8Y + 10 + 12.5Z = 105.3X + 12.5X$.

Second thickener, $117.8Z + 12.5X = 117.8Y + 12.5Y$.

Third thickener, $12.5Y = 117.8Z + 12.5Z$.

Solving these equations gives:

$$X = 0.095.$$

$$Y = 0.0101.$$

$$Z = 0.00098.$$

The caustic lost in the mud from the last thickener is, therefore, $12.5 \times 0.00098 = 0.0122$ ton, or about 0.1 per cent.

This method of analyzing a continuous process by means of material balances over parts of the process is extremely useful in solving a wide variety of chemical engineering problems.

Small Discontinuous Plants.—It is not necessary to use the above system for causticizing soda ash. The process is a fairly simple one and it may not be possible to justify the cost of a continuous process for small plants. It would obviously be satisfactory to provide an agitation vessel in which lime and soda ash may be mixed with water; and this vessel should be large enough so that the batch may be held for the proper length of time. This might be followed by a series of cylindrical settling tanks with cone bottoms and hinged draw-off pipes. A batch would be run to one of these tanks, allowed to settle, and the clear liquid decanted. Wash water would then be added, thoroughly mixed with the precipitate, and the batch allowed to settle. This should be repeated as many times as might be necessary, preferably, of course, using the wash water in counter-current. That is, fresh water would be used only on the precipitate that was nearly free from caustic. The clear liquor from this wash would be the next to the last wash on the next batch and so on until the strongest wash would be sent to the agitator where the lime and soda would be mixed. Such a system may be analyzed by the method of material balances exactly as in the problem worked for the Dorr system.

Evaporation.—In concentrating caustic solutions, whether they be from the chemical process or the electrolytic process, certain difficulties are met. First, caustic solutions have a considerable elevation in boiling point, which, as pointed out in Chap. II, causes a loss of available temperature drop in multiple-effect evaporators. Second, the stronger solutions are dense and viscous, with the result that the rate of heat transfer is low. Third, caustic solutions act on steel causing what is known as *caustic embrittlement*. Steel after long exposure to such solutions becomes so brittle that in some cases plates and tubes can be cracked with a blow of a hammer. All of these factors must be taken into consideration in the design of caustic evaporators.

Former practice was to use standard vertical-tube evaporators very much like the evaporator of Fig. 6. In recent years, how-

ever, practice has shifted to the types of evaporators to be described under electrolytic caustic. These evaporators must be provided with equipment for removing crystalline salts because, as the concentration of sodium hydroxide increases, there is a crystallization of a mixture of sodium carbonate, sodium chloride, and sodium sulfate. The first of these is present because of incomplete conversion, the other two were present as impurities in the original soda ash. It is usual to interrupt the evaporation at 50 per cent and cool, or clarify, the 50 per cent liquor because at this concentration the solubility of the impurities is a minimum. Over moderate distances it is cheaper to ship 50 per cent solution than to evaporate it to solid and ship the solid; hence an appreciable fraction of all the caustic sold is shipped as 50 per cent solution.

The clarified 50 per cent liquor is usually concentrated to 75 per cent in a single-effect evaporator, and then evaporation to anhydrous caustic is done in fuel-fired pots. All of the above operations are so similar to those to be described in detail under electrolytic caustic that they will not be considered further at this point.

ELECTROLYTIC CAUSTIC

In 1807, Sir Humphry Davy showed that the passage of an electric current through fused salt would separate it into sodium and chlorine. With the development of the dynamo, interest was aroused in industrial electrochemistry. The first patent on a practical cell for electrolyzing salt solutions appeared in 1886. This was followed by a period of intense development, and a wide variety of cells was proposed. These received relatively little interest in a practical way until along in the 'eighties and 'nineties, when attempts were made to electrolyze salt solutions for the commercial production of caustic. These efforts met with varying degrees of success, and by about 1900 the electrolytic manufacture of caustic assumed commercial importance. Since 1910 the development of such plants has been very rapid, and now about half of all the caustic made in the world is made by some electrolytic process.

Flow Sheet.—Figure 43 is a flow sheet of a plant for making caustic by an electrolytic process.⁽⁶⁾ If the plant purchases solid salt, this must be first dissolved to a saturated brine. Many plants, however, obtain a saturated brine from the wells, as

described on page 12. This impure brine is freed from calcium, magnesium, and iron compounds by treatment with soda ash and lime or caustic. The precipitate is allowed to settle and the resulting mud is discarded. The purified brine is heated and

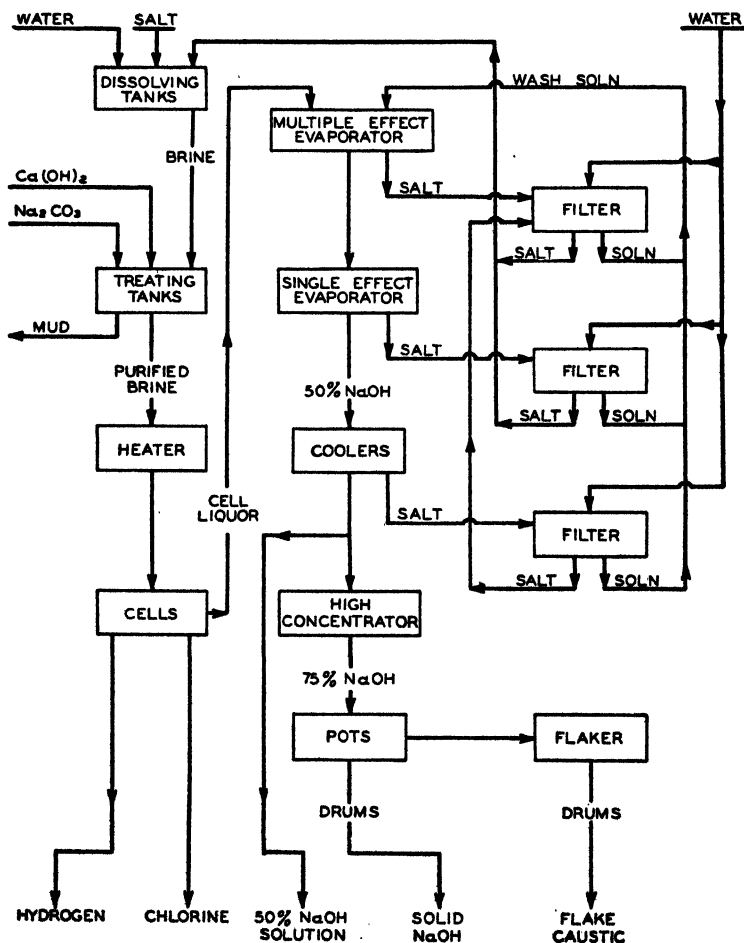

Fig. 43.—Flow sheet for electrolytic-caustic process.

sent to electrolytic cells. These cells produce at the cathode a solution in which approximately one-third to one-half of the salt has been converted into sodium hydroxide, and they also yield at the cathode an amount of hydrogen equivalent to the amount

of caustic formed. At the anode, an approximately equivalent amount of chlorine is liberated.

The cell liquor is concentrated to 50 per cent NaOH in multiple-effect evaporators. No two plants are exactly alike, and there may be various combinations of triple, double, or single effects in series. For instance, there may be a triple effect concentrating cell liquor to 35 per cent, and a single effect concentrating from 35 per cent to 50 per cent; or there may be a triple effect concentrating to 30 per cent and a double effect from 30 per cent to 50 per cent. During this operation, most of the unconverted sodium chloride separates and is removed from the evaporator by any of the usual methods. It is washed as free of caustic as possible and is returned to the salt dissolving tanks. If it contains a trace of caustic, this may replace lime in the purification.

The hot 50 per cent solution from which the bulk of the salt has been filtered is usually cooled to remove still more sodium chloride. The sodium chloride so crystallized is usually very fine, so that it has to be filtered on a special type of filter and it cannot be washed free from caustic. Consequently, it is usually returned to one of the other filtration operations.

Much of the cooled, clarified, 50 per cent solution is sold as such, and the rest is concentrated to 70 to 75 per cent NaOH in single-effect evaporators heated by high-pressure steam. At present, a small amount of 75 per cent solution is shipped as such, but most of the 75 per cent solution goes to caustic pots. Wash liquors from the various filters are returned to some point in the evaporation cycle, usually with the cell liquor fed to the multiple-effect evaporators.

Chemical Theory.⁽⁷⁾—An electrolytic caustic cell is essentially a vessel containing a saturated solution of sodium chloride with two chemically inert electrodes at opposite sides of the vessel. The solution contains the following ions: Na^+ , Cl^- , H^+ , OH^- . A direct current passes between these electrodes, and a porous diaphragm prevents the solution around the anode mixing with the solution around the cathode. At the anode the principal reaction is the liberation of gaseous chlorine according to the equation



Chlorine is somewhat soluble in water or brine; and some of the chlorine liberated at the surface of the anode is dissolved and

reacts with water as follows:



This means that the liquor about the anode is acid, and contains a concentration of hypochlorite ions fixed by the concentration of brine and the temperature. Both of these factors affect the solubility of chlorine. If OH^- ions from the cathode reach the anode region they are neutralized by the H^+ ions, thus decreasing the concentration of acid in the anode region, allowing more chlorine to dissolve, and increasing the concentration of OCl^- ions.

There is a potential for each ion below which it cannot be discharged. This potential varies with the temperature, the character of the electrode surface, and the concentration. As the current density is increased, the potential drop between solution and electrode increases. In commercial caustic cells the current density is high, the potential drop at the surface of the electrode is large, and most ions that reach the electrode surface will be deposited simultaneously.

Since the concentration of chlorine ions at the surface of the anode is far greater than that of any other anion, the principal reaction at the anode must be that represented by equation (43). The concentration of hypochlorite ions, though much lower, is appreciable. These are discharged according to the following equation:

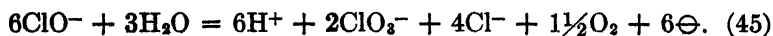

Thus chlorate is formed and oxygen liberated. Most salt contains calcium sulfate, and in the brine treatment only the calcium ions are removed while the sulfate ions remain in solution. Some sulfate ions are discharged at the anode, probably according to the reaction



The anode liquor is always acid and hence the concentration of hydroxyl ions in the anode compartment is extremely low. Even so, there must be a slight discharge of hydroxyl ions according to the reaction



All the above secondary reactions liberate oxygen. The anode is always dense graphite. The oxygen is nascent when liberated, and combines to a certain extent with the graphite to form carbon dioxide. This is accelerated if the anode is porous, for the electrolyte in the pores is not renewed; its sodium chloride is ultimately exhausted, and the secondary reactions [especially equation (47)] predominate.

At the cathode the principal reaction is

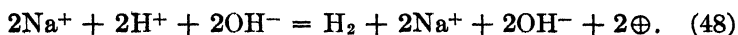

Hydrogen, and not sodium, is the primary cathode product, as the least potential at which sodium ions could be discharged on an iron cathode, is at least 2 volts greater than that required to discharge hydrogen ions, even from a strongly alkaline solution. There are no secondary cathode reactions of any importance in these cells.

The Diaphragm.—It has been shown that the anode liquor will be acid, and will contain hypochlorite ions and dissolved chlorine, while the cathode liquor will be alkaline. The evolution of gas at the electrodes tends to keep the liquid in each chamber stirred. If the anode and cathode liquors were allowed to mix, the products of the cell would be only hydrogen and sodium hypochlorite, because the acidity of the anode layer would be so far reduced that all the chlorine would dissolve. The primary purpose of the diaphragm, therefore, is to prevent this mixing.

A commercial cell must operate continuously. Brine is fed to the anode compartment, and caustic solution withdrawn from the cathode compartment. Liquid must, therefore, flow through the diaphragm from anode to cathode. If the diaphragm is to be most effective, it should offer an hydraulic resistance to the flow of the electrolyte; so that this flow will be everywhere at right angles to the diaphragm, and therefore directly away from the anode and directly toward the cathode. In practice, the diaphragm is usually made of layers of asbestos paper pressed against the surface of a perforated sheet-steel cathode. As fast as electrolyte passes through the diaphragm into the cathode chamber it is drained away. The hydrostatic head at the bottom of the diaphragm is greater than at the top, and hence the flow through a new diaphragm will be much more rapid at the bottom. Traces of calcium and magnesium salts not removed

in the brine purification precipitate in the diaphragm by reaction with caustic as they approach the cathode. This precipitate accumulates fastest in the parts of the diaphragm where the flow is most rapid, and thus establishes a more nearly uniform flow.

Electricity is carried through an aqueous solution by the physical transport of ions. There is, therefore, a movement of anions from the cathode chamber to the anode, and of cations from the anode chamber to the cathode. The important anions in the cathode liquor are chlorine and hydroxyl. Under the influence of the current both of these tend to move through the diaphragm toward the anode. The brine on the anode side of the diaphragm is acid, and hence has a very low concentration of hydroxyl ions. This anode brine is slowly filtering through the diaphragm, so that within the diaphragm itself there is a gradient of hydroxyl concentration from slightly acid on the anode side to strongly alkaline on the cathode side. The position of the boundary between acidity and alkalinity depends upon the relative magnitude of opposing factors. The flow of brine tends to carry this boundary toward the cathode. The transport of hydroxyl ions by the current, and diffusion, tend to carry this boundary toward the anode. The thickness of the diaphragm and its porosity are selected to obtain a proper balance of these factors. Most of the electricity carried by anions is carried by hydroxyl ions in the cathode chamber, by decreasing proportions of hydroxyl ions and increasing proportions of chlorine ions through the diaphragm, and largely by chlorine ions and to a less extent by hypochlorite ions in the anode chamber. Similarly, that portion of electricity carried by cations is carried by hydrogen ions in larger proportion in the anode chamber and in smaller proportion in the cathode chamber. Sodium ions carry the rest of the electricity carried by cations. As chlorine is evolved at the anode and sodium ions are carried through the diaphragm, there is a tendency for the anode liquor to become dilute by the action of electrolysis alone.

Current Efficiency.—According to Faraday's law, 96,500 coulombs should deposit 1 gram equivalent of product at each electrode. This quantity of electricity is known as 1 Faraday. The current efficiency of an electrolytic cell is defined as the ratio of the amount of the desired product formed to the amount

of this product which theoretically could be formed. Because of different proportions of secondary reactions at the two electrodes, the anode current efficiency is not necessarily the same as the cathode current efficiency. In speaking of electrolytic caustic cells, if the term *current efficiency* is used without further specification, it is always understood to mean the cathode current efficiency.

Voltage Efficiency and Energy Efficiency.—Energy consumed for converting the material fed to the cell into the products taken from the cell is supplied as electrical energy. The total energy theoretically necessary to form 1 gram-equivalent of product is obtained by multiplying the number of coulombs in 1 Faraday by a potential drop. This potential drop, called the decomposition voltage, may be calculated by the Gibbs-Helmholtz equation for any case where the heat of reaction and the change of decomposition voltage with temperature are known.⁽⁸⁾ The Gibbs-Helmholtz equation is

$$E = \frac{Q}{JF} + T \frac{dE}{dT}, \quad (49)$$

where E = decomposition potential in volts.

Q = heat of reaction in calories for 1 gram-equivalent of product.

J = calories per joule.

F = coulombs per Faraday.

T = Absolute temperature in degrees Kelvin.

In some cases the second term of the right-hand member may be neglected, without introducing an error greater than 10 per cent. For most caustic cells the decomposition voltage is approximately 2.3 volts.

This potential drop is obviously the theoretical minimum which could cause the reaction in question. The actual potential across any cell is always greater than this, because of the potential drop due to the internal resistance of the cell, and because of polarization at the electrodes which prevents the reaction taking place reversibly. The ratio of the theoretical decomposition potential to the actual voltage drop across the cell is the voltage efficiency. The energy efficiency is obviously the product of the voltage efficiency and the current efficiency. *Decomposition*

efficiency is the ratio of mols of caustic formed to mols of salt fed to the cell.

Brine Supply.—The electrochemical plants in the Detroit district operate on saturated brine obtained directly from salt wells. In most other districts salt is purchased and dissolved to make a saturated brine. In all cases, these brines must be purified from calcium, magnesium, and iron compounds; for, if untreated brine enters the cells, insoluble hydroxides would precipitate in the pores of the diaphragm so rapidly as to shorten greatly its life.

This purification could be accomplished by the use of sodium carbonate and lime. It is simpler to leave sufficient caustic in the salt returned from the evaporators than to use lime, and this is general practice. However, an excess of caustic in the salt from the evaporators must be avoided; or if such an excess should be present, the treated and settled brine must be neutralized with hydrochloric acid. Any caustic entering the anode compartment with the brine feed is quantitatively converted to hypochlorite. This results in chlorate in the cathode liquor, oxygen discharge at the anode, and shortened anode life.

Since the brine always contains calcium sulfate, this treatment leaves sodium sulfate in solution. The undesirable results of the presence of sulfate in the cell have been pointed out in discussing equation (46). Sodium sulfate is almost insoluble in strong caustic solutions, but small amounts do pass into the finished product. If the brine used is low in sulfates, this may maintain the sulfate concentration in the brine fed to the cells at a satisfactorily low value. If the quantity of sulfate entering the process is greater than that leaving in the concentrated caustic, sulfate may be removed, and an undesirable accumulation prevented, in two ways. Salt recovered from the evaporators may be given a wash to remove most of the caustic, and then a second wash to remove sulfates. This second wash is discarded. There are methods for the removal of sulfates from partly concentrated caustic solutions that involve the formation of certain complex salts of low solubility. These are used to a certain extent but are too complicated to be discussed in this text.

Cells.—Many different types of cells and a large variety of cell constructions have been described in the literature. Several of these have had considerable commercial success from time to

time until they have been superseded by better designs. At present there are only three or four diaphragm cells that enjoy extensive commercial use in the United States.

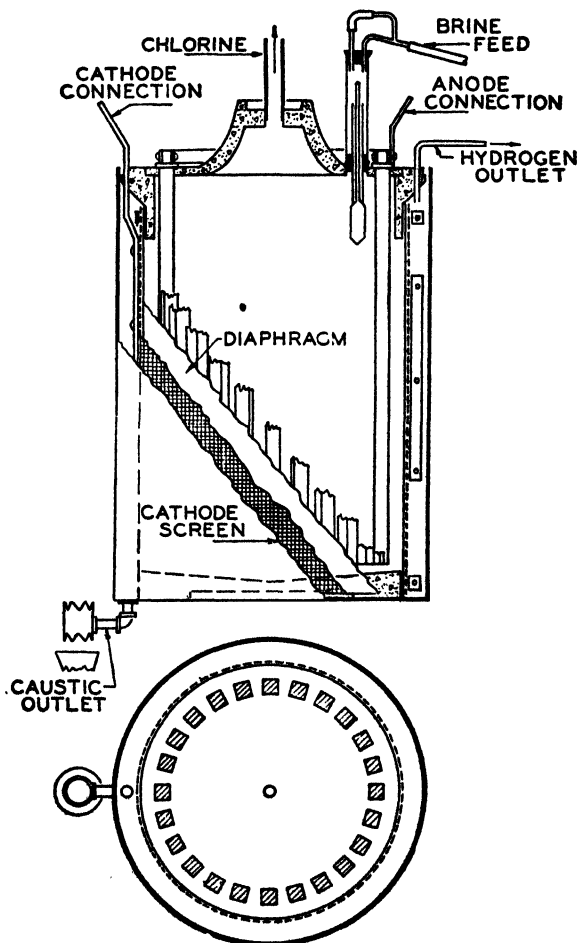

FIG. 44.—Gibbs-Vorce cell.

The *Gibbs-Vorce* cell (Fig. 44) is a vertical, cylindrical cell.^(9,10) The bottom of the cell is a circular disk of concrete. Rising from this is a cylinder of perforated sheet steel which forms the cathode. Inside of the cathode are two or more layers of asbestos paper which form the diaphragm. Outside the cathode is a cylindrical

sheet-steel cathode chamber. The cell is closed by a concrete cover, having a central outlet for chlorine and carrying a number of graphite rods, 2 by 2 by 36 inches, arranged in a circle, close to the inside of the diaphragm. The brine is fed into the top of the cell through a float-operated control, and is drawn off from the bottom of the cathode chamber. The assembled cell is 26 inches in diameter by 42 inches high, and takes about 1,000 amperes.

The *Hooker Type-S* cell⁽¹¹⁾ (Fig. 45) is a recent development that has replaced the old Townsend cell, which has often been

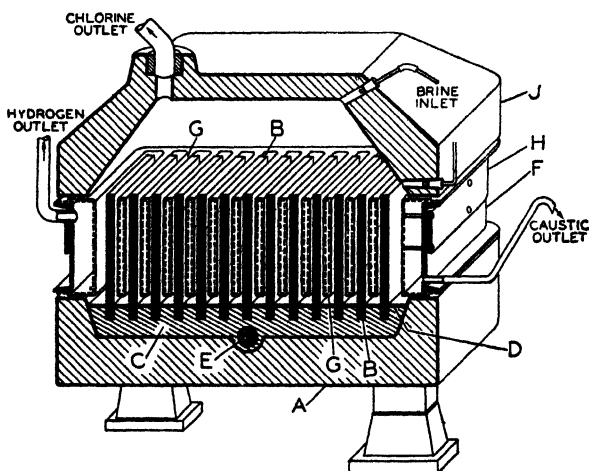

FIG. 45.—Hooker Type-S cell.

mentioned in the literature. The cell is rectangular in plan. The base consists of a block of concrete *A* from which a number of flat sheets of graphite *B* rise as anodes. They are held in place by a layer of lead *C* cast around their bases and fitting into the concrete bottom of the cell. The lead is covered with an insulating layer of asphalt *D* between the anodes. To this lead block is also fastened the main anode connection *E*. On top of the concrete base rests the cathode assembly *F*, which consists of a ring of channel iron with a number of cathode pockets *G* projecting inwardly from it. The cathode assembly also carries the hydrogen and caustic outlets and the cathode connection *H*. The pockets are made of wire screen and are covered with a diaphragm. The

cell is completed by a concrete cover *J*, which carries the exit connection for chlorine and an inlet for brine.

The diaphragm is formed in place on the cathode pockets by submerging the cathode assembly in a suspension of asbestos pulp and applying suction to the inside of the cathode pockets, thus essentially filtering out the asbestos onto the cathode pockets to form the diaphragms. The construction of this cell gives a large anode and cathode surface for a given amount of floor space; and because of the nearly cubical construction of the cell, radiation losses are small, permitting the cell to operate at a high temperature. The cells take 5,000 to 7,000 amperes per cell.

The *Dow* cell is known to be used in very large commercial installations, but its description has not been published.

Several other cells are in commercial operation at present in relatively small numbers. The *Allen-Moore* cell, which was widely used at one time, is still in operation in a number of plants but is gradually being superseded.

Mercury Cells.—The mercury cells^(7,10) differ basically in principle from the diaphragm type of cells. These cells employ a cathode of mercury, which is circulated through the cell, and anodes of graphite. Particularly at high current densities, the voltage required to discharge hydrogen on a bright metallic surface, such as mercury, may exceed the theoretical discharge voltage by as much as 1.4 volts. The sodium deposited at the cathode forms an amalgam with mercury with the evolution of heat, and the voltage required for the deposition of sodium on a mercury cathode is therefore considerably less than would be required to deposit sodium on an iron cathode. As a result, the primary cathode product is sodium, and not hydrogen. However, if the current density is low, the overvoltage of hydrogen is decreased; and if through slow circulation of the mercury the concentration of sodium in the amalgam becomes high, the energy required for the deposition of sodium is increased. Under either or both of these conditions, hydrogen may be liberated at the cathode, and if so liberated will contaminate the chlorine liberated at the anode. Under good operating conditions, the cathode current efficiency should be approximately 95 per cent.

Brine purification for the mercury cells must be at least as complete as for the diaphragm cells, because any calcium, magnesium, and iron in the brine would be preferentially deposited

in the mercury, resulting in a viscous amalgam and poor performance of the cell.

The sodium-mercury amalgam is passed out of the cell proper into a decomposition cell, which is a short-circuited primary cell in which the amalgam becomes an anode and iron or graphite is the cathode. Water is added to this cell. The reaction which takes place is



The water used for the decomposition of the amalgam should not contain impurities that are not wanted in the final product. Impurities in the water for the decomposition are also undesirable in that they adversely affect the performance of the decomposition cell. The quantity of water is so regulated that there is produced directly a 50 per cent NaOH solution.

The mercury cell has the disadvantage that the operating voltage (and therefore the power consumption) is considerably greater than for the modern diaphragm cell. On the other hand, it produces directly pure 50 per cent NaOH solutions, with considerable saving in evaporation and purification costs.

The literature contains many descriptions of mercury cells. Apparently, however, the cells that are now in commercial use, and which have not been described in the literature, differ from the older cells in more or less essential details of construction. It appears to be without point to discuss the older cells. Mercury cells are built with current capacities comparable to the range of current capacities found in the diaphragm cells. Apparently mercury and diaphragm cells are about competitive, and one can not predict at this time which of these cells may prove superior for the production of a caustic of the highest purity.

Operation and Control of Diaphragm Cells.⁽¹²⁾ *Chlorine and Hydrogen Removal.*—The chlorine coming directly from the cell is wet, and therefore it must be handled in stoneware pipe up to the point at which it is dry. It is usually removed under a slight suction, but this suction is kept to a small fraction of an inch of water to avoid contaminating the chlorine with air drawn in through leaks. More recent cell designs have improved the situation by reducing the number of points at which possible leaks into the chlorine system might occur. If chlorine-drying equipment is placed between the cells and the fan, dry chlorine gas may be handled by a plate steel fan painted with asphalt.

Hydrogen, usually used for ammonia synthesis or hydrogenation, is taken off under a slight suction. The hydrogen lines usually contain screens at frequent intervals to prevent explosions traveling back through the pipe.

Current Density.—High anode current density tends to increase the discharge of hypochlorite and sulfate ions and therefore shortens the life of the anodes. The current density at the cathode determines the rate at which caustic is formed in the brine that percolates through the diaphragm; therefore, with a given diaphragm porosity (and consequently a given rate of percolation), an increase in the current density will increase the proportion of the sodium chloride converted to caustic, and hence will decrease the amount of evaporation per pound of caustic produced. The dissolved chlorine that enters the cathode chamber neutralizes some caustic, forming chloride and hypochlorite. For a given rate of percolation (and hence a given rate of chlorine input into the cathode chamber), the amount of caustic so neutralized will be a greater proportion of the total caustic formed as the rate of caustic formation is less. Consequently, if the cathode current density is very low, the cathode current efficiency will be low. If the cathode density is very high, the current efficiency will be low because the concentration of salt in the cell will be so reduced and the concentration of caustic at the cathode so increased that a larger percentage of the electricity will be carried by hydroxyl ions, which will make their way into the anode chamber. The maximum current efficiency, therefore, will be at some intermediate value; and conditions can usually be chosen so as to give a cathode current efficiency of at least 95, and often 96 per cent. By the same reasoning, it follows that for a given current density, a very high percolation rate results in low yields because of excessive amounts of dissolved chlorine entering the cathode chamber; and a very low rate of percolation has a similar result because of excessive concentration of hydroxyl ions in the cathode chamber. Current density and rate of percolation are usually so balanced as to give a decomposition efficiency of 30 to 55 per cent. A decomposition efficiency of 50 per cent calls for a percolation rate of about 0.5 cubic centimeter per ampere per hour per square foot of diaphragm.

Cell Voltage.—The voltage across the cell depends on the current density and the internal resistance of the cell. Current

density affects the voltage because an increase in current density increases the potentials at which the ions are discharged, and because it affects the IR drop through the cell. The internal resistance of the cell depends on the distance between electrodes, the area of electrodes, the porosity of the diaphragm, and the temperature and concentration of the brine. A new cell operates on a relatively low voltage, 3 to 3.5 volts. As the cell continues in operation, the diaphragm gradually clogs, and thus cuts down the effective cross-section of the brine passage between anode and cathode and the rate of percolation. One of the advantages of the Hooker Type-S cell is that, due to the construction of the cover, the brine level can be increased as the diaphragm clogs, and consequently constant rates of percolation and of decomposition efficiency can be maintained over longer periods of time. However, in this cell, as in all diaphragm cells, the resistance of the diaphragm finally reaches the point where it must be replaced. The anodes are gradually attacked and disintegrated. This results in increasing the distance between electrodes and decreasing the anode area, with a consequent increase in cell resistance and cell voltage, so that anodes also must be replaced at intervals.

Evaporation of Electrolytic Caustic Solutions.—On page 158 were mentioned some of the problems that arise in the concentration of caustic soda solutions. In the case of electrolytic caustic solutions, there is added a fourth problem; namely, the removal of the large quantities of salt that separate as the solution concentrates. The cell liquor may contain 8 to 11 per cent NaOH and 15 to 18 per cent NaCl. At 50 per cent NaOH the solution will only contain about one per cent NaCl. Hence in evaporation of cell liquor to 50 per cent the amount of salt precipitated will be more than 100 per cent of the caustic, and in some cases may be double the caustic.

The difficulties caused by caustic embrittlement are extremely serious. It has been known for a long time that nickel was the only metal suitable for tubes that would be resistant to caustic and yet not subject to caustic embrittlement. Nickel is too expensive to use in the construction of such evaporators as those shown in Fig. 6. In order to use nickel, it was necessary to develop an evaporator in which high coefficients of heat transfer could be obtained in order to reduce the amount of nickel in the evaporators to an economical figure.⁽¹²⁾ The velocity of the

liquid over the heating surface is the most important single factor controlling the rate of heat transfer. As a result of this logic, a forced-circulation evaporator has been developed, in which the liquid is pumped over the heating surfaces at a positive velocity. The continual demands for caustic of higher purity, especially of low iron content, has accelerated the shift toward nickel. Cast iron is quite resistant to caustic and many evaporators have cast iron bodies with nickel heating elements. For caustic of the highest purity, however, substantially all evaporators handling solutions stronger than 35 per cent NaOH are so built that the caustic comes in contact with nickel only. This means the use of nickel-clad plate steel for the bodies, nickel tubes for the heating elements, and nickel pipes and pumps for circulating the liquid.

Such an evaporator is shown in Fig. 46. *A* is the heating element, which contains a number of vertical nickel tubes, usually about $\frac{3}{4}$ inch in diameter and from 8 to 12 feet long. This heating element is provided with connections for the admission of steam and for withdrawing condensate and noncondensable gases. Because it is usually convenient to place the steam connection below the top of the heating element, an internal baffle *B* is built so that the steam rises to the top of the heating element behind this baffle and then passes down around the tubes, washing condensate and noncondensable gases ahead of it.

This heating element projects possibly one-half of its length into the evaporator proper, *C*. From the evaporator head a discharge pipe leads to the circulating pump *D*; and the feed to the evaporator is usually introduced just before the pump. The level of the liquid in the head *C* is kept below the top of the heating element *A*. The liquid and steam issue from the top of the tubes at such a high velocity that much of the liquid would pass out with the vapor as spray if it were not for the baffle, or deflector, *E*, which throws the spray down into the main body of liquid in the evaporator head. The pump *D* is so proportioned that the velocity of the liquid at the entrance to the tubes is of the general order of 10 feet per second.

Although the forced-circulation evaporator is more free from difficulties from salting and scaling than any other design, it is nevertheless necessary to remove continuously the precipitated salt. To do this, there is provided for each evaporator body a

settler *F*, which is usually a short cylinder, of approximately the same diameter as the evaporator head, with a cone bottom. Part of the liquid is withdrawn continuously from the vapor head *C* by the pump *G* and pumped into one side of the settler *F* near the top. There is usually a short baffle just inside the liquid inlet to prevent too much disturbance. On the opposite side from the

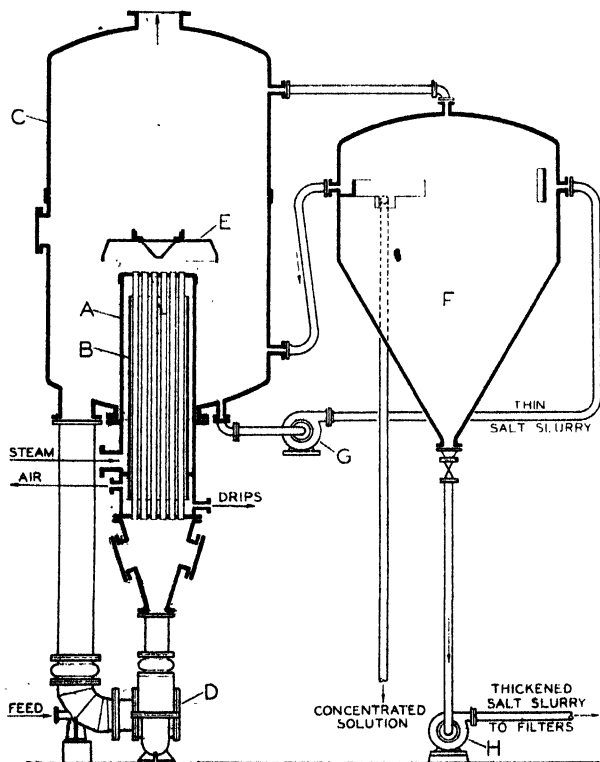

FIG. 46.—Forced-circulation evaporator and salt settler.

liquid inlet is a launder which collects the clear solution, part of which overflows by gravity back to the evaporator proper, and part of which is withdrawn as the concentrated solution. A thick slurry of salt and solution is withdrawn continuously from the point of the settler cone by pump *H* and sent to salt filters.

There are a considerable number of such evaporators in operation in which the construction of the evaporator proper is exactly as shown in Fig. 46, but in which the construction and position

of the salt settler may vary considerably from that shown. Figure 46 shows the most favored construction at the present time.

Recently, a few caustic evaporators have been built in which the heating element, instead of being vertical and projecting into the evaporator body, is horizontal and entirely outside of and below the evaporator body. The evaporator body then becomes merely a flash chamber, out of which the solution is pumped, to pass through the heater and then to be flashed into the evaporator body proper. Not enough of these evaporators are in operation, nor have they been in operation long enough, to determine whether or not either type has pronounced advantages over the other.

Caustic solutions have much higher elevations in boiling point than solutions of common salt, and in the design of caustic evaporators this consideration is paramount. This elevation in boiling point is due partly to the caustic and partly to the salt. Data for these boiling points are given in Fig. 47, in which the boiling points of the solution are plotted as ordinates against the boiling points of water at the same pressure as abscissas. For a solution of constant composition, the resulting line is straight and is called a Dühring line.⁽¹⁴⁾ In Fig. 47, each line represents a solution having a constant ratio of NaOH to H₂O and saturated with NaCl at its boiling point. Since the solubility of sodium chloride in caustic solutions increases somewhat with temperature, the lines of Fig. 47 do not represent solutions of constant composition, but the experimental evidence available indicates that they are still essentially straight lines.⁽¹⁵⁾

It is also necessary to have data available on the solubility of sodium chloride in caustic solutions of different strengths and at different temperatures. Such data are given in Table XXXI in the Appendix.

In the description of Fig. 43 on page 161, it was indicated that the exact arrangement of an evaporator flow sheet in a caustic plant may be highly variable. Because of the universal practice of cooling caustic at 50 per cent to remove salt, a discussion of evaporation problems naturally subdivides into first, evaporation up to 50 per cent, and second, evaporation beyond 50 per cent.

As an illustration, first of the use of the data of Fig. 47 and Table XXXI; and second, as an illustration of the line of reasoning

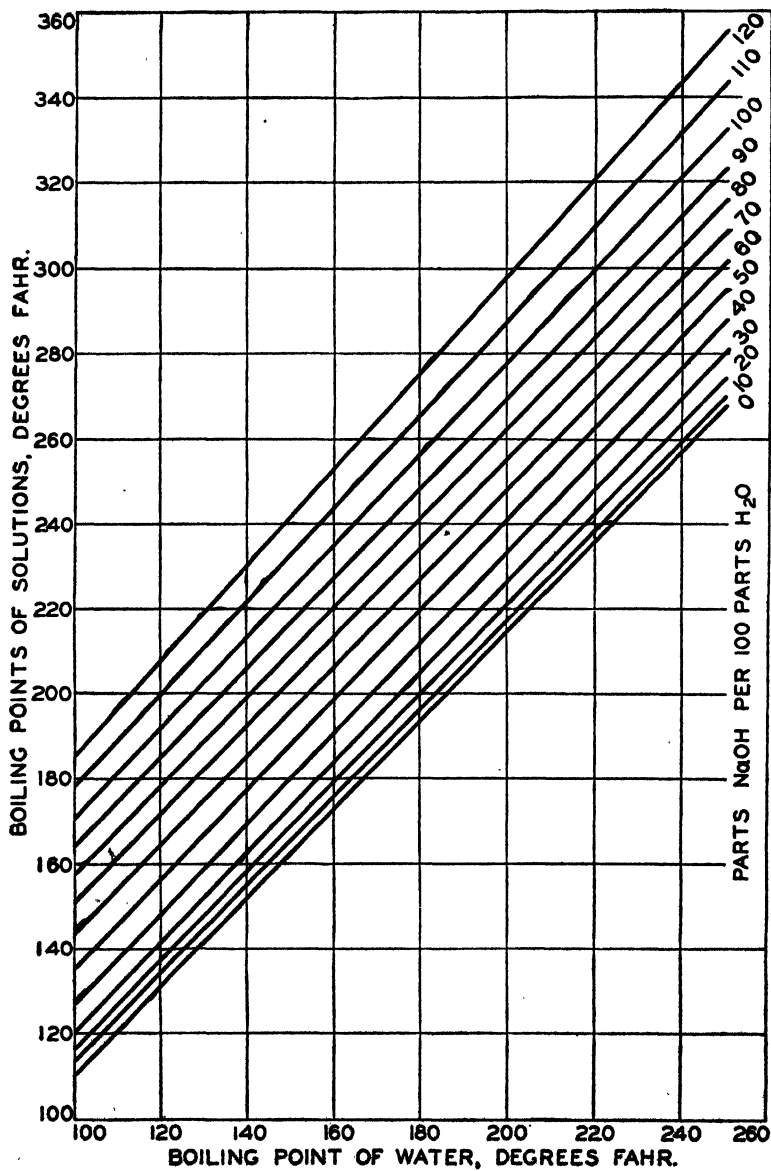

FIG. 47.—Boiling points of electrolytic-caustic solutions.

that leads to these variable evaporator flow sheets, two cases will be considered in detail. In both cases it will be assumed that there is available cell liquor of the following composition:

Composition	Grams per liter	Per cent
NaOH.....	108	8.85
NaCl.....	225	18.40
Na ₂ SO ₄	4	0.33

Specific gravity..... 1.22

It will also be assumed that saturated steam at 55 pounds gage is available. This steam has a saturation temperature of 303°F. The final vacuum on all evaporators will be 26 inches (referred to a 30-inch barometer). This corresponds to a saturated vapor temperature of 125°F. The two cases to be considered are (I) evaporation from cell liquor to 50 per cent in a triple effect evaporator; and (II) evaporation from cell liquor to 35 per cent in a triple effect evaporator, and from 35 per cent to 50 per cent in a single effect evaporator. Both triple effects will be assumed to

CASE (I).—EVAPORATION FROM CELL LIQUOR TO 50 PER CENT NaOH
Basis—100 pounds cell liquor

	Pounds H ₂ O	Pounds NaOH	Pounds NaCl	Pounds Na ₂ SO ₄	Pounds total
Cell liquor.....	72.42	8.85	18.40	0.33	100.00
50 per cent NaOH.....	8.30	8.85	0.55	17.70
Removed.....	64.12	17.85	0.33	82.30

CASE (II).—EVAPORATION FROM CELL LIQUOR TO 35 PER CENT AND FROM
35 TO 50 PER CENT

	Pounds H ₂ O	Pounds NaOH	Pounds NaCl	Pounds Na ₂ SO ₄	Pounds total
Cell liquor.....	72.42	8.85	18.40	0.33	100.00
35 per cent NaOH.....	15.30	8.85	1.18	0.33	25.66
Removed in triple.....	57.12	17.22	74.34
35 per cent NaOH.....	15.30	8.85	1.18	0.33	25.66
50 per cent NaOH.....	8.30	8.85	0.55	17.70
Removed in single.....	7.00	0.63	0.33	7.96

operate with backward feed (*i.e.*, the cell liquor will be fed into the last effect and the concentrated solution will be withdrawn from the first effect). All calculations will be based on 100 pounds of initial cell liquor.

From the data of Table XXXI the material balances shown in the tables at the bottom of page 177 may be calculated.

An examination of these material balances shows one advantage of Case (II). Here practically all the salt has been precipitated at 35 per cent NaOH. Solutions of caustic as strong as 50 per cent are viscous and good salt crystals cannot be obtained from them. Case (II) separates a negligible amount of salt under these conditions whereas Case (I) produces nearly one-third of the salt under these conditions. In Case (I) a considerable amount of salt will have to be filtered from a 50 per cent mother liquor, while in Case (II) most of the salt is filtered from a mother liquor not stronger than 35 per cent, which means that the salt in Case (II) can be washed free from caustic much more readily.

At a first approximation it will be assumed that each effect of the triple evaporates one-third of the total water evaporated in the triple. This is not strictly correct, but is a necessary assumption in determining the approximate concentration of the solutions in the different effects. The conditions for the two cases are shown in the following table:*

CASE (I)

	Pounds H ₂ O	Pounds NaOH	Pounds NaCl	Pounds Na ₂ SO ₄	Pounds total
Cell liquor.....	72.4	8.85	18.4	0.33	100.0
Feed to second effect.....	51.1	8.85	12.8	0.33	73.1
Removed in third effect....	21.3	5.6	26.9
Feed to second effect.....	51.1	8.85	12.8	0.33	73.1
Feed to first effect.....	29.8	8.85	5.5	0.33	44.5
Removed in second effect..	21.3	7.3	28.6
Feed to first effect.....	29.8	8.85	5.5	0.33	44.5
50 per cent.....	8.3	8.85	0.5	17.7
Removed in first effect....	21.5	5.0	0.33	26.8

* Since this calculation is only a rough approximation, solubilities of NaCl have been taken at 100°C. (Table XXXI) instead of approximate evaporator temperatures.

CASE (II)

	Pounds H ₂ O	Pounds NaOH	Pounds NaCl	Pounds Na ₂ SO ₄	Pounds total
Cell liquor.....	72.42	8.85	18.4	0.33	100.0
Feed to second effect.....	53.38	8.85	15.5	0.33	78.1
Removed in third effect....	19.04	2.9	21.9
Feed to second effect.....	53.38	8.85	15.5	0.33	78.1
Feed to first effect.....	34.34	8.85	7.2	0.33	50.7
Removed in second effect....	19.04	8.3	27.4
Feed to first effect.....	34.34	8.85	7.2	0.33	50.7
35 per cent.....	15.30	8.85	1.2	0.33	25.7
Removed in first effect....	19.04	6.0	25.0

From these data it is possible to make the first approximation of the elevation in boiling point in each one of the effects as follows:

CASE (I)

	Approximate per cent NaOH	NaOH per 100 H ₂ O	Approximate boiling point elevation
Solution in third effect.....	12	17.3	16°F.
Solution in second effect.....	20	29.7	25°F.
Solution in first effect.....	50	106.5	86°F.

CASE (II)

	Approximate per cent NaOH	NaOH per 100 H ₂ O	Approximate boiling point elevation
Solution in third effect.....	11	16.5	16°F.
Solution in second effect.....	17	25.8	22°F.
Solution in first effect.....	35	57.8	46°F.
Solution in single effect.....	50	106.5	86°F.

Based on the above approximations, a complete calculation of the heat and material balances for each evaporator and the size of the evaporators becomes possible. The exact method for carrying out these calculations is beyond the scope of this book. The final results of such calculations are shown in the following table, and the distribution of the total available temperature drop

	Case (I) Triple to 50 per cent	Case (II)	
		Triple to 35 per cent	Single 35 to 50 per cent
Saturation temperature in third effect	125°	125°	
Boiling point elevation	16°	16°	
Boiling point in third effect	141°	141°	
Working temperature drop in third effect	13°	24°	
Estimated heat transfer coefficient	1.000	1.000	
Steam to third effect—Saturation temperature in second effect	154°	166°	
Boiling point elevation	25°	22°	
Boiling point in second effect	179°	188°	
Working temperature drop in second effect	16°	32°	
Estimated heat transfer coefficient	800	900	
Steam to second effect—Saturation temperature in first effect	195°	220°	125°
Boiling point elevation	86°	46°	86°
Boiling point in first effect	281°	266°	211°
Working temperature drop in first effect	22°	37°	92°
Estimated heat transfer coefficient	600	700	500
Steam to first effect	303°	303°	303°
Based on 100 pounds cell liquor:			
Salt removed, pounds	18.85	17.22	0.63
Water evaporated	64.12	57.12	7.00
Total heating surface, square feet	5.28	2.35	0.15
Steam used, pounds	28.2	25.6	7.81
Economy	2.28:1	2.24:1	0.896:1
Total available working temperature drop	51°	94°	92°

SUMMARY

	Heating surface, square feet	Steam used, pounds
Case (I)	5.28	28.2
Case (II)	2.50	33.4

between the amounts available for heat transfer and those lost as the elevation in boiling point is shown in Fig. 48.

While the same steam pressure to the first effect has been assumed for these comparative calculations, it should be noted that in practice a lower steam pressure would be used for the triple effect of Case (II), so that the body of the first effect would not be much above atmospheric pressure. A decrease in steam pressure used in the triple effect of Case (II) would be an additional advantage in case this steam were exhausted from a prime mover.

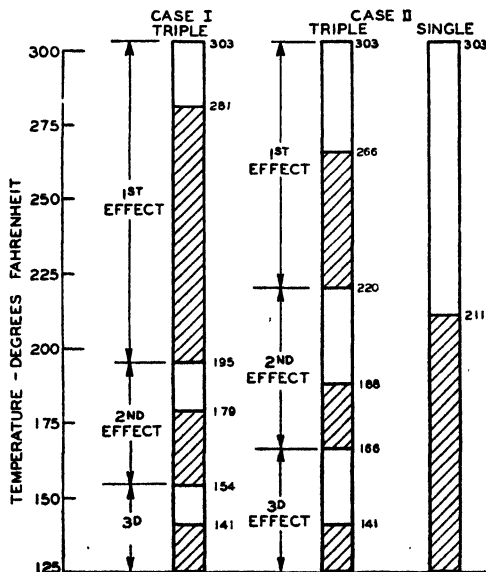

Fig. 48.—Effect of elevation in boiling point on multiple-effect evaporator capacity.

The choice of the exact evaporator system to be used will depend on the cost of steam, the steam pressure available, the cost of power, the first cost of the evaporators, the amount of space available in the building, and other considerations. The computations leading to this choice are too intricate to be discussed in this text. The variation of these factors from one plant to another, complicated by the fact that all caustic plants are continually changing their capacity and their methods of operation, results in the wide variety of evaporator installations that are found in different plants.^(16,17)

Table XXXI shows that 50 per cent caustic at 100°C. contains 6.24 pounds of NaCl per hundred pounds of NaOH. At 20°C. the corresponding figure is 1.8 pounds of NaCl per hundred pounds of NaOH. Practically all plants cool their 50 per cent caustic solutions from the temperatures at which they leave the evaporator (which may be as high as 140°C.) to 20°C. in continuous crystallizers to remove as much salt as possible. Theoretically, a greater removal of salt could be accomplished by concentrating to 60 per cent NaOH, but this additional concentration increases the viscosity of the caustic sufficiently so that the salt formed from 60 per cent solutions would be too fine to filter. In practice, the salt removed by cooling the 50 per cent solution contains much of the Na_2SO_4 in the original cell liquor, and some methods for removing sulfates involve the treatment of this fine salt.

Cooled and filtered 50 per cent NaOH solution can be shipped in ordinary steel tank cars. As previously pointed out, from one-third to one-half of all the electrolytic caustic made is shipped as 50 per cent solution. Although there has recently been a tendency to ship 75 per cent solution, this is not usual because of the high freezing point of stronger solutions. Consequently, all caustic that is not sold as 50 per cent solution is ordinarily finished to solid caustic.

The fuel efficiency of the pots (see page 183) is very low, much lower than that of the steam boiler. Consequently, it is economical to carry the evaporation as far as possible in steam-heated evaporators before going to direct-fired equipment. It is standard practice at the present time to concentrate to 75 per cent NaOH in a single-effect steam-heated evaporator. With a vacuum of 27 inches on the evaporator, this calls for steam at 75 to 100 pounds gage. No salt is precipitated during this operation; therefore the evaporator is extremely simple, and the only special precautions necessary are that all pumps and pipe lines handling 75 per cent solution must be steam-jacketed to prevent freezing.

Purification of Caustic.—Many industries demand caustic lower in salt than can be produced by cooling a 50 per cent solution of electrolytic caustic to 20°C. Some of this material is supplied by chemical caustic made by the ammonia-soda plants, and some is supplied by giving electrolytic caustic a special treat-

ment to remove sodium chloride. A third source of low-salt caustic is the caustic from mercury cells.

About the lowest salt content that can be reached by cooling 50 per cent caustic is approximately 1 per cent NaCl in the 50 per cent solution. This means that when this material is concentrated to fused caustic the resulting product will contain about 2 per cent of NaCl. This is too high for some users. There are two general methods for lowering the salt content. In both methods it will be assumed that the caustic has been concentrated to approximately 50 per cent and cooled to remove as much salt as possible by simple crystallization.

One method involves diluting this cool 50 per cent solution to about 35 per cent NaOH, and cooling to 10 to 15°C. This results in the formation of crystals of the compound $\text{NaOH}\cdot 3\frac{1}{2}\text{H}_2\text{O}$, and all of the sodium chloride remains in the mother liquor. These crystals can then be melted and concentrated in nickel to give a very pure caustic. If the solution were concentrated to 35 per cent and then cooled, a mixed crystal containing sodium chloride would be obtained. If a solution of 51 to 52 per cent is cooled, the compound $\text{NaOH}\cdot\text{H}_2\text{O}$ is obtained; but unless conditions are very carefully controlled NaCl precipitates at the same time.

The other method depends on the formation of a slightly soluble salt whose composition is usually given as $\text{NaCl}\cdot\text{Na}_2\text{SO}_4\cdot\text{NaOH}$.⁽¹⁸⁾ In the operation of this process a cooled 50 per cent solution is treated with solid Na_2SO_4 under such conditions as to result in the formation of this triple salt. There can be a still further treatment of the same general nature to eliminate any excess of Na_2SO_4 .

Caustic Pots.—For finishing to solid caustic, direct heat is necessary. The melting point of pure sodium hydroxide is 318°C. In order to keep the caustic fluid and to drive off the last of the water, the charge is actually finished at 450 to 500°C. A few plants send caustic to the pots at 50 per cent, but in most cases it is concentrated in evaporators to as high as 75 per cent because of the low fuel economy in the pots.

Caustic pots are hemispherical cast-iron vessels without any draw-offs or other connections. They are mounted in brickwork (Fig. 49) in such a way that the pot is not exposed directly to the flames. Baffles are built so that the flue gas must circulate

around the pot before it passes to the stack. These pots must be of an unusually dense and fine-grained cast iron, and their manufacture requires great skill so that only three or four foundries in the United States can cast satisfactory caustic pots.

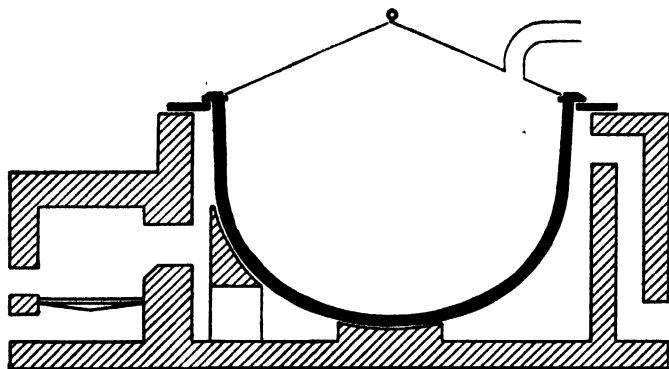

FIG. 49.—Caustic pot.

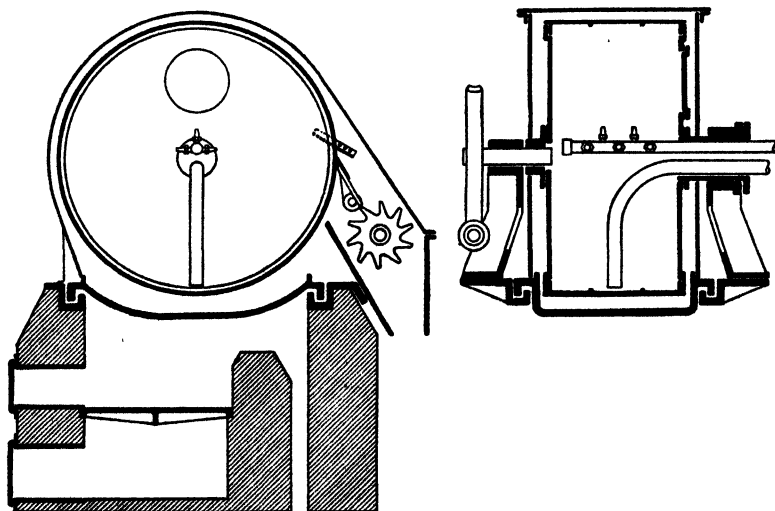

FIG. 50.—Caustic flaker.

The life of these pots is uncertain and their replacement represents an appreciable item of expense in finishing caustic.

When the water is boiled off, the fused caustic is allowed to settle, and some reagent is added to precipitate dissolved iron. Iron is present as sodium ferrate $[(\text{NaO})_2\text{Fe}]$. The treatment

consists in adding reducing agents, such as sulfur or sodium thio-sulfate, to reduce the iron and precipitate it as ferrous sulfide (FeS). The charge is then allowed to stand until the precipitate has settled. A specially constructed centrifugal pump is lowered into the pot, and the clear caustic pumped out to drums or to a flaker. The flaker (Fig. 50) consists of a smooth cast-iron roll provided with connections so that the inside may be water cooled. The bottom of this roll dips into a bath of fused caustic, kept hot by a small fire, and as the roll slowly rotates, a film of caustic is carried around on its surface and solidified. This is removed on the far side of the roll by scrapers, broken into flakes by a beater, and these are packed in steel drums for shipment.

Relative Importance of Chemical and Electrolytic Caustic.—Twenty-five years ago the world's consumption of chlorine was approximately one-third of its consumption of caustic. Consequently, the production of electrolytic caustic was limited by the amount of chlorine that could be sold, and the rest of the world's consumption of caustic was made by the chemical process, mainly at ammonia-soda plants. Since that time the world's demands for chlorine have increased at an extremely rapid rate. The result is that in 1940 the production of electrolytic caustic was greater than the production of chemical caustic for the first time in history. The demands for chlorine seem to be increasing faster than the demands for caustic, and the probable result will be one of two things. Either because of the continual increase in electrolytic caustic made, the price of caustic will be lowered to the point where large new uses can be found, or else the ammonia-soda process as a producer of caustic must continue to take a less and less important position. At the present time no predictions can be made as to which way the industry will develop, but it is quite positive that there is a rapidly increasing demand for chlorine and a tendency for a surplus of caustic to accumulate.

CHLORINE

Before the development of the electrolytic process all chlorine was made from hydrochloric acid, derived from common salt. The LeBlanc process for soda produced hydrochloric acid in large amounts; and as legislation regarding the disposal of this acid became more stringent, attempts were made to convert it to chlorine. Chlorine so made found a market as bleaching powder,

which now became available in quantities and found a use in the rapidly developing textile industries.

For the manufacture of chlorine, two processes were developed.^(19,20) In the *Weldon process*, hydrochloric acid was treated with manganese dioxide, usually in stills made of stone slabs. This gave chlorine gas of high concentration. The manganese dioxide was so expensive that it was necessary to regenerate it from the still waste by adding lime and blowing air through the mixture. This resulted in a compound of manganese of the general formula $MnO \cdot MnO_2$. Consequently, only about one-third of the hydrochloric acid was converted to chlorine, while about two-thirds went to form manganous chloride. The regeneration process recovered the manganese, but the chlorine was lost as a solution of calcium chloride.

In the *Deacon process* a mixture of hydrogen chloride and air was passed over heated brickbats which had been previously saturated with cuprous chloride. This catalyst was not sufficiently active to accomplish complete oxidation of hydrogen chloride to chlorine and water. The resulting gas was considerably diluted with the nitrogen of the air used for oxidation. Both of these processes were unsatisfactory; the Weldon process because of its low recovery, and the Deacon process because of the dilute product. Processes for liquefying chlorine had not been developed at this time, and the product of both processes was absorbed in lime to form bleaching powder.

With the introduction of the electrolytic cell it became possible to produce directly chlorine of high concentration. The position of bleaching powder was so firmly established that for many years all the chlorine produced electrolytically was converted to this product. The first serious attempts to liquefy chlorine on a large scale were made about 1910; and now practically all chlorine sold is sold as liquid chlorine. Liquid chlorine possesses a number of advantages over bleach. It is much more concentrated for shipping, is more easily employed by the consumer, and does not deteriorate on storage. The liquefying process is much easier to operate and requires much less space. The manufacture of synthetic hydrochloric acid from hydrogen and chlorine has completely reversed the original situation.

Bleaching Powder.—The decline of bleaching powder as an important form of available chlorine is indicated by the following figures:

	1923	1939
Production of bleaching powder.....	146,700 tons	16,000 tons
Production of liquid chlorine.....	62,700 tons	455,000 tons

When chlorine gas is passed over dry hydrated lime at a temperature below 50°C., the following reaction takes place:



This compound, which is often incorrectly called calcium hypochlorite, can be shown to have the following formula:

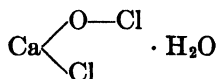

When hypochlorites are used for bleaching, one hypochlorite ion will reduce two equivalents of hydrogen

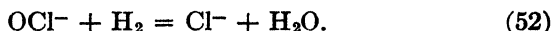

On dissolving bleaching powder in water, one molecule of bleach furnishes one active hypochlorite ion and one inert chlorine ion.

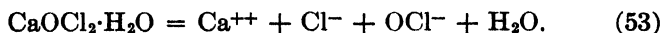

From this point of view, all the chlorine in bleach may be considered available, since 1 molecule of bleach will oxidize 2 equivalents of hydrogen.

Bleach is unstable and gradually decomposes, even at ordinary temperatures, according to the following reaction:



This evolution of oxygen may even cause the explosion of the drums in which the bleach is packed. At higher temperatures reaction (54) is accelerated. The following reaction may also take place, especially above 35°C.:

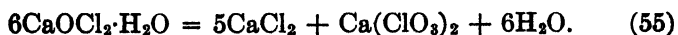

All of the chlorine involved in these two decompositions is rendered unavailable for bleaching purposes. If the lime used contains magnesium hydrate, the corresponding magnesium compound is formed; but its decomposition, according to reactions similar to equations (54) and (55) is much more rapid.

Formerly bleaching powder was made on a large scale by spreading a thin layer of dry slaked lime on the floor of large concrete chambers.⁽¹⁶⁾ Chlorine gas was passed at low velocities through several such chambers in series. At present what little bleaching powder is made, is made by bringing chlorine into contact with dry hydrated lime in a rotating sheet-steel cylinder. This is set at a slight pitch and is provided with lifting baffles on the inside to shower the lime down through the gas. Some heat is evolved in the reaction. This is taken care of by radiation in cold weather and by water sprays on the steel shell in warm weather. The bleach is loaded in steel drums holding 700 pounds. Ordinarily, it is considered that bleach should be used in from 6 to 10 weeks from the time it is made because of the loss of available chlorine due to reactions (54) and (55).

LIQUID CHLORINE

Production and Distribution.—In 1939 about 455,000 tons of liquid chlorine were made, and its distribution was as follows:

TABLE XXII.—DISTRIBUTION OF LIQUID CHLORINE IN 1937

	Per cent
Pulp and paper.....	34
Organic chemicals.....	32
Heavy chemicals.....	17
Textiles.....	5
Miscellaneous.....	12

The average price in 1937 was 1.8 cents a pound.

Theory.—The vapor pressure of liquid chlorine is shown in table XXIII.

The latent heat of evaporation of chlorine at 68°C. is 101 B.t.u. per pound. The critical temperature of chlorine is 291°F. and its critical pressure is 76.1 atmospheres. The partial pressure of chlorine gas in contact with liquid chlorine at any given temperature cannot be greater than the pressure shown in the above table, or some gas will condense. If the liquid were in contact with chlorine gas whose partial pressure were less than that in the above table, liquid would at once evaporate until equilibrium was restored.

In the above discussion, reference was made to the partial pressure of chlorine gas. If pure chlorine were considered, the partial pressure would obviously be equal to the total pressure. If

the gas is not pure, the total pressure on the system must be the sum of the partial pressures of chlorine and of the impurities. Consequently, an impure gas requires more pressure for liquefaction at a given temperature than a pure gas. When an impure gas is liquefied, as the condensation of liquid chlorine progresses, the chlorine concentration in the residual gas decreases. That combination of pressure and temperature which would just cause

TABLE XXIII.—VAPOR PRESSURE OF LIQUID CHLORINE

Temperature, degrees Fahrenheit	Pressure, atmospheres absolute	Pressure, pounds per square inch
-20	1.30	19.1
-10	1.63	24.0
0	2.00	29.4
10	2.43	35.7
20	2.95	43.4
30	3.50	51.4
40	4.20	61.7
50	4.95	73.8
60	5.80	85.2
70	6.80	99.9
80	7.90	116
90	9.15	135
100	10.50	155
110	12.10	178
120	13.80	203
130	15.70	231
140	17.75	261
150	19.90	293
160	22.20	326
170	24.65	362
180	27.35	402

initial condensation would give a negligible yield; for this initial condensation would result in a more impure residual gas. It is usually convenient in practice to compress all the gas to the final pressure, and then to cool in steps, so that only a fraction of the total gas needs to be cooled to the final temperature. It should also be noted that in the neighborhood of their points of liquefaction, practically all gases deviate appreciably from Boyle's and Charles' laws. This deviation is in the direction of an actual density greater than the calculated one. Consequently, the volume-

composition of the gases in equilibrium with liquid chlorine cannot be calculated accurately from an analysis of the expanded gases.

Drying Equipment.—The gas from the cells is first cooled as far as the temperature of the available water supply will permit, but not below 50°F., because of the danger of the formation of solid chlorine hydrates. This cooling may be done in banks of stoneware or Duriron pipe, immersed in water or with water showered over them.

For several reasons, the gas must be more completely freed from water than this cooling will accomplish. Besides the danger of formation of chlorine hydrates, cooling below 32°F. would result in the formation of ice. The compression, liquefaction, and storage of chlorine require the use of steel equipment, and this will be rapidly corroded if the chlorine is not perfectly dry. Carbon dioxide is also objectionable, as solid carbon dioxide may separate in the refrigeration system; but this is usually controlled by cell operation rather than by introducing any step for removing it. Complete drying may be accomplished by scrubbing with strong sulfuric acid in stoneware towers containing suitable packing. Another system involves passing the gas through stoneware tourills that contain concentrated sulfuric acid.

Compressors.—An early difficulty in using ordinary reciprocating compressors was lubrication. Not only does chlorine convert all types of oils to gummy substances, but the action of chlorine on the oil liberates hydrochloric acid. Concentrated sulfuric acid has been found satisfactory for the lubrication of these compressors. There are also in service reciprocating compressors with graphite piston rings working without lubrication. The commonest compressor now in use is the Nash Hytor with concentrated sulfuric acid as the sealing liquid. By operating with any of these compressors the chlorine is usually compressed to 35 to 80 pounds gage. It should be noted that if the chlorine contains even small quantities of hydrogen, explosions are apt to occur under compression.

Refrigeration.—Table XXIII shows that at 35 pounds gage, the temperature for liquefaction must be under 30°F. If the chlorine were pure, it would be possible to liquefy it completely under these conditions. Since it is always impure, it must be cooled to temperatures considerably below 30°. The cooling is

done in steps. The heat of compression may be removed by cooling with water, but the later stages of cooling require artificial refrigeration. At each stage, chlorine liquefies until the partial pressure of chlorine in the residual gas is in equilibrium with the liquid at that particular temperature. For high-percentage recovery the last stage may involve cooling to -20 to -50°F . At -20°F . the vapor pressure of liquid chlorine is 19.1 pounds absolute. If the total pressure is 35 pounds gage, or 49.7 pounds absolute, the composition of the gas phase will be approximately 38 per cent chlorine by volume. Consequently, if the liquefaction is finished at -20°F . and 35 pounds gage, approximately 1 volume of chlorine must be discarded for every 2 volumes of inert gas. Formerly, when this discarded gas was converted into bleaching powder, such operation was satisfactory. Today most plants compress to higher pressures than 35 pounds and cool to lower than -20°F . The discarded gas may be burned to make hydrochloric acid, or it may be used for chlorinations. The exact temperature and pressure in the liquefaction process depend in each plant on the uses for the waste gas. When this waste gas must be as little as possible, the liquefaction process may involve compression to 80 pounds and cooling to -50°F . or lower.

Receivers.—Chlorine is stored in the plant in ordinary iron tanks, properly designed for the pressures that might occur in warm weather. All parts of the liquid chlorine end of the system are heavily insulated to keep the temperature as low as possible. From the storage tanks, chlorine is drawn to ordinary steel cylinders for small users. For larger users, chlorine may be shipped in two types of tank cars. In one type, a number of horizontal steel cylinders are assembled on a flat car. Each cylinder holds 1 ton, and may be removed from the car to the plant where it is to be used. The other type is a standard tank car built to withstand the pressures that might develop in summer weather, and heavily insulated. Such tank cars may hold as much as 20 tons.

References

- (1) PARTINGTON, J. R., "The Alkali Industry," Chap. III, D. Van Nostrand Company (1925).
- (2) HOU, T.-P., "Manufacture of Soda," Chap. XVI, The Chemical Catalog Company (1933).
- (3) PIPER, W. E., *Trans. Am. Inst. Chem. Eng.*, **24**, 1-14 (1930); *Chem. Met. Eng.*, **37**, 362-365 (1930).

- (4) GOODWIN, *J. Soc. Chem. Ind.*, **45**, 360T-364T (1926).
- (5) DORR, J. V. N., *Ind. Eng. Chem.*, **19**, 558-561 (1927).
- (6) ANON., *Chem. Met. Eng.*, **40**, 466 (1933).
- (7) ALLMAND and ELLINGHAM, "Applied Electro-Chemistry," pp. 392-395; 420-423, Longmans, Green & Co. (1924).
- (8) THOMPSON, "Theoretical and Applied Electro-Chemistry," pp. 64-65, The Macmillan Company (1925).
- (9) KIRKPATRICK, S. D., *Chem. Met. Eng.*, **35**, 158-161 (1928).
- (10) MANTELL, C. L., "Industrial Electrochemistry," Chap. XVII, McGraw-Hill Book Co. (1940). See also *Chem. Met. Eng.*, **47**, 166-168 (1940).
- (11) STUART, K. E., LYSTER, T. L. B., and MURRAY, R. L., *Chem. Met. Eng.*, **45**, 354-358 (1938).
- (12) MOORE, H. K., *Trans. Am. Inst. Chem. Eng.*, **13**, (I), 11-46 (1920).
- (13) BADGER, W. L., *Trans. Am. Inst. Chem. Eng.*, **18**, 231-248 (1926).
- (14) BAKER, E. M. and WAITE, V. H., *Trans. Am. Inst. Chem. Eng.*, **13**, (II), 223-232 (1921).
- (15) MONRAD, C. C. and BADGER, W. L., *Ind. Eng. Chem.*, **21**, 40-42 (1929).
- (16) PRITCHARD, D. A. and GOLLOP, G. E., *Ind. Eng. Chem.*, **16**, 1056-1062 (1924).
- (17) LEE, J. A., *Chem. Met. Eng.*, **37**, 404-408 (1930).
- (18) HUBEL, J. H., *Can. Chem. Met.*, **17**, 52 (1933); *Chem. Abs.*, **27**, 2384 (1933).
- (19) LUNGE, "Sulfuric Acid and Alkali," Vol. III, D. Van Nostrand Company (1911).
- (20) THORPE, "Dictionary of Applied Chemistry," Vol. II, Longmans, Green & Co. (1921).

Problems

1. Chemical caustic is made by causticizing soda ash of 96 per cent Na_2CO_3 with lime containing 95 per cent CaO . The causticizing batch is made up by using wash water containing 0.5 per cent NaOH , and 92 per cent of the actual Na_2CO_3 is causticized. The final solution contains 9.5 per cent NaOH , and 10 tons of such solution are made per hour. How much soda ash and lime are used?

2. A plant is manufacturing chemical caustic as 8 per cent solution. A three-stage Dorr continuous leaching system is used, and its characteristics are such that the sludge from each thickener carries 2 pounds of water per pound of inert solids. The soda ash used is 98 per cent pure (2 per cent insoluble) and the lime used is 95 per cent Ca(OH)_2 (5 per cent insoluble). The lime and soda ash are mixed in stoichiometric proportion and the reaction may be assumed to go to completion. Production is 100 tons per day of 8 per cent caustic solution. How much NaOH is lost per day?

3. A cell room has 120 Gibbs-Vorce cells. These are arranged as two parallel circuits of 60 cells each, the current in each circuit is 1,000 amperes, and each cell has a voltage drop of 4.16 volts. The anode and cathode current efficiencies are each 95 per cent. What is the energy efficiency?

4. In Problem 3, what would be the actual yield of caustic and chlorine per day?

5. If the hydrogen and the chlorine both leave the cell at 50°C. saturated with water vapor, if the cell is fed with brine containing 25 per cent NaCl, and if the decomposition efficiency is 45 per cent, what is the composition of the exit cathode liquor?

6. Cell liquor of the composition given on page 177 is to be concentrated to 25 per cent NaOH in a triple-effect evaporator, from 25 to 40 per cent NaOH in a double-effect evaporator, and from 40 to 50 per cent NaOH in a single-effect evaporator. In a similar manner to the preliminary calculations on page 177, calculate the concentration of solution in per cent NaOH and per cent NaCl, leaving each effect of each evaporator, and the pounds of salt precipitated in each evaporator per hundred pounds of cell liquor.

7. Three different electrolytic plants produce dry chlorine gas containing, respectively, 95, 80, and 60 per cent Cl₂. Each of these gases is liquefied at 40 pounds gage and -20°F. What is the maximum theoretical percentage yield of liquid chlorine from each gas?

CHAPTER VIII

MISCELLANEOUS PRODUCTS

This chapter will discuss the manufacture of some of the more important inorganic products. There has been no attempt to make this chapter exhaustive. Many substances not mentioned here are made on the industrial scale and are regular articles of commerce. Those that are mentioned have been selected either because they are manufactured in large tonnages, or because their technology involves points of special interest.

ALUM

The term *alum* is used in general chemistry to indicate double sulfates of aluminum and one of the alkali metals, or of chromium and the alkali metals. Ordinary commercial usage at present recognizes as alum only aluminum sulfate, $\text{Al}_2(\text{SO}_4)_3 \cdot 18\text{H}_2\text{O}$. The double sulfates of aluminum or chromium with the alkali metals are known commercially as *crystal alums* or *chrome alums*, or by the specific name of the alkali metal, such as *potash alum* or *soda alum*.

Production and Uses.—In 1937, there were produced in the United States 362,000 short tons of alum at an average value of \$22.27 per ton, and 33,000 short tons of crystal alums at an average value of \$54.20 per ton.

Alum is used principally in the sizing of paper and as a coagulant for the purification of water. These two uses, respectively, account for 35 and 55 per cent of the total production.

The usual specifications for alum for water-treating plants call for not less than 17 per cent soluble Al_2O_3 . Since the formula $\text{Al}_2(\text{SO}_4)_3 \cdot 18\text{H}_2\text{O}$ corresponds to 15.3 per cent Al_2O_3 , it is obvious that these specifications demand material containing less than the theoretical percentage of water of crystallization. The ratio of Al_2O_3 to SO_4 in the product may or may not correspond to the formula, as there may be either more or less than the theoretical amount of oxide in the finished product.

Methods of Manufacture.—The raw material is bauxite. This is mined in Georgia and Arkansas, and is also imported from France and South America. The formula $\text{Al}_2\text{O}_3 \cdot 2\text{H}_2\text{O}$ has been given to this substance, but the material actually mined may contain between 1 and 3 molecules of water. It always contains some iron and silica. The soluble Al_2O_3 content may be 52 to 57 per cent, and soluble Fe_2O_3 may be about 1 per cent, although even the ore from one mine may vary widely in composition.

The crude ore is crushed to a fine powder (practically all through a 200-mesh screen) and leached with 60°Bé. sulfuric acid.⁽¹⁾ This operation may be carried out in lead-lined vats equipped with paddle agitators, or continuously by the use of such devices as the Dorr agitator (Fig. 42b). The materials are so proportioned that there is an excess of 0.1 to 0.2 per cent of soluble Al_2O_3 . The mixture is kept at 105 to 110°C. by open steam jets or lead steam coils. From 15 to 20 hours are required to complete the reaction, and at the end of this time the solution contains part of the insoluble matter in a very finely divided state. Most of the iron has been oxidized to the ferric condition, especially if air has been used for agitation. If the operation is carried out in batches, the charge is allowed to settle, the supernatant liquid is drawn off, and the residue washed two or three times. The washings are combined with the strong solution. A more concentrated final solution will be obtained if a counter-current decantation system is used for washing. The density of the liquor from either process may be between 25 and 30°Bé.

In order to remove finely divided suspended material, some coagulable substance may be added which will flocculate in an acid solution and occlude the suspended matter. Some substance is also added to reduce the iron to a ferrous condition. Barium sulphide, sodium sulphide, hydrogen sulphide, sodium bisulphite or sulfur dioxide may be used. After clarification, reduction, and settling, the clear liquid is ready for concentration. Evaporation is usually carried out in open lead-lined wood tanks containing lead steam coils. The solution is usually concentrated to 62°Bé., at which density it solidifies at about 80°C. Cast lead multiple-effect evaporators could be used, if care were taken to finish the solution in the first effect at a temperature enough above its freezing point so that there is no danger of solidification

in the evaporator or pipe lines. The concentrated solution is usually run into iron pans or onto a cooling table, or sometimes merely onto a brick floor. It solidifies quickly, and when cold is broken into rough lumps or crushed to uniform powder.

A batch process has been described⁽²⁾ in which the time of reaction has been shortened to 2 hours. In this case the heat of reaction is liberated in so short a time that it is not lost by radiation, and no heating is needed in the digester.

COPPERAS

Copperas is the name given by the trade to the compound $\text{FeSO}_4 \cdot 7\text{H}_2\text{O}$. It is used as a coagulant in treating water. Considerable amounts are roasted to form rouge (Fe_2O_3), which is used as a paint pigment, and in polishing. In 1939 the production of copperas was 35,000 tons, at an average price of \$12.60 per ton.

Methods of Manufacture.—Copperas is produced from waste pickling liquor from steel mills. These liquors vary greatly in specific gravity and free acid. The gravity may vary from 17 to 33°Bé. and the free acid will approximate 2 per cent. The liquor is first run into neutralization tanks of wood or of acid-proof brick, provided with lead heating coils. The free acid is neutralized with scrap iron. The length of time required is a function of temperature, surface, and agitation; and it takes from 12 to 60 hours to reduce the free acid to 0.03 per cent. After the liquor has left the neutralization tanks it may be handled in cast iron or bronze. The neutralized liquor is filtered in gravity filters. These are generally constructed of wood and have a filter bed of excelsior, graded coke, or sand.

The filtered liquor is concentrated to approximately 42°Bé. in triple-effect vacuum evaporators. These are constructed of extra-heavy castings and have copper tubes. The hot concentrated liquor from the evaporator is run either to a batch or a continuous crystallizer, and on cooling will deposit crystals of $\text{FeSO}_4 \cdot 7\text{H}_2\text{O}$ until the gravity has fallen to about 26°Bé. The crystals and mother liquor are discharged into a centrifuge. The crystals are then washed in the centrifuge with a spray of warm water, and the wash and mother liquors are returned either to the neutralization tank or to the evaporator. The crystals are dried with warm air in rotary drum driers. They may be

screened if desired. Steel-mill liquors are capable of supplying many times as much copperas as the market will absorb, and the disposal of these liquors is becoming a serious problem in the light of legislation governing stream pollution.

COPPER SULFATE

The principal uses of this salt are in the manufacture of insecticides, the sterilization of water in municipal reservoirs, and for copper plating. Most of the copper sulfate on the market is a by-product of copper refining, and is simply crystallized from a weakly acid solution in lead-lined tanks.

In 1937, 78,900,000 pounds were made, with an average value of 4.9 cents per pound.

SODIUM SULFATES

Sodium sulfates come on the market in several forms. These are:

Glauber's Salt.—This is crystallized $\text{Na}_2\text{SO}_4 \cdot 10\text{H}_2\text{O}$.

Anhydrous Sodium Sulfate.—This is Na_2SO_4 , obtained by crystallization, or by the dehydration of Glauber's salt.

Salt Cake.—This is the by-product resulting from the treatment of common salt with sulfuric acid in the manufacture of hydrochloric acid.

Niter Cake.—This is NaHSO_4 obtained as a by-product in the manufacture of nitric acid from Chile salt-peter.

The principal uses for the neutral sulfates are in the manufacture of glass, and in the Kraft or sulfate process for the manufacture of wood pulp. Considerable quantities are also used for salting-out dyes and in dyeing operations. In 1939 the production of Glauber's salt was 34,500 tons; of salt cake, 224,700 tons; and of niter cake, 34,100 tons. The average sales prices were \$15.60, \$10.20, and \$17.80, respectively.

Some Glauber's salt is prepared from salt cake by neutralizing and crystallizing in open vats or continuous crystallizers. A much more important source is from the recovery of rayon spin-bath, which is a liquor produced in the rayon process. The spin-bath is concentrated and then cooled in vacuum crystallizers with the production of a large crop of crystals of Glauber's salt. The mother liquor is fortified with fresh acid and returned to the rayon process.

Since Glauber's salt is approximately 44 per cent sodium sulfate and 56 per cent water, it is obvious that it would be uneconomical to ship this long distances if the anhydrous salt could be easily prepared. Crystals of Glauber's salt dehydrate readily; but this gives a bulky product that cannot be easily handled; particularly in the Kraft process, where it is added to a fused bath, the blast in the furnace would blow the powder away before it could be melted.

Figure 51 is the solubility curve for sodium sulfate. Above the critical point at 92°F ., only the anhydrous salt can separate.

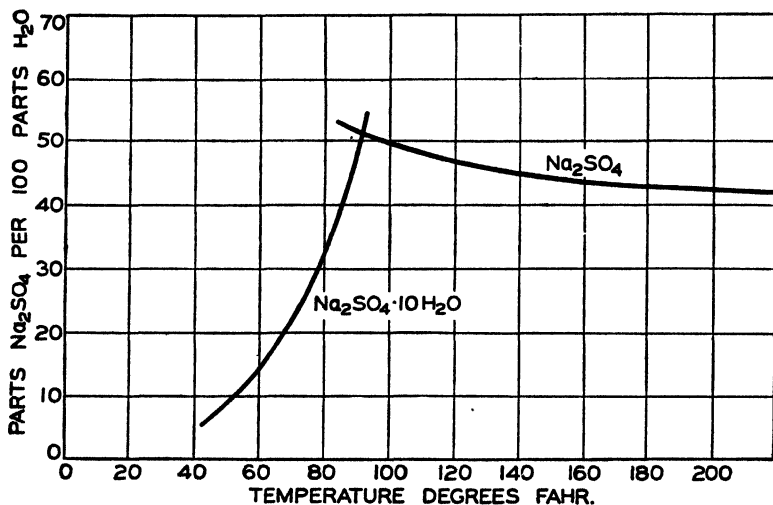

FIG. 51.—Solubility of sodium sulfate.

It would seem easy to evaporate solutions above this temperature and produce the anhydrous salt; but the anhydrous salt has an inverted solubility curve and, therefore, rapidly forms scale on the heating surfaces of an evaporator. Special systems for this evaporation would seem to be indicated, but they have not proved economical; and the usual evaporators for anhydrous sodium sulfate are of the standard vertical-tube type of Fig. 6. The sodium sulfate scale that forms is removed by frequent boil-outs with water.

There are enormous natural deposits of nearly pure sodium sulfate in northern Saskatchewan. While these deposits are far from possible markets, one concern is producing anhydrous

sodium sulfate from this material by calcining it in oil-fired rotary kilns. Decrease in the production of nitric acid from Chile saltpeter and sulfuric acid has greatly decreased the availability of niter cake, which is required for the separation of copper and nickel sulfides in the metallurgy of nickel. For this purpose crude sodium sulfate (88 to 90 per cent pure) from Saskatchewan is heated in oil-fired cast-iron retorts, each of which has a capacity of 20 to 30 tons of niter cake per day.⁽³⁾ The powdered sodium sulfate is continuously mixed with 66°Bé. sulfuric acid, and the slurry is continuously fed into the retort. The resulting molten niter cake flows out continuously through a tap hole into molds in the form of a continuous bucket conveyer. The molds are run through a trough filled with cooling water, and the frozen blocks of niter cake are discharged from the end of the conveyer. About 200 tons per day of niter cake are produced by this process.

HYPHO

Sodium thiosulfate ($\text{Na}_2\text{S}_2\text{O}_3 \cdot 5\text{H}_2\text{O}$) is universally known to the trade as *hypo*. It is used in photography and, to a small extent, as an antichlor in bleaching.

Hypo may be made by boiling a solution of sodium sulfite with sulfur. The resultant solution is cooled and hypo crystals separated. This and many other inorganic methods have been described in the literature, but most of the hypo on the market in this country is recovered as a by-product in the manufacture of sulfur dyes.

These dyes are made by fusing sulfur, caustic soda, and certain organic substances. When fusion is finished, most of the sulfur and the caustic is present as hypo. The mixture is leached with water and the dye removed by filtration. The mother liquor is clarified and then crystallized. The process is extremely simple; and since sulfur dyes, especially sulfur black, are made on a very large scale, this process alone could supply all of the hypo needed for the market.

EPSOM SALTS AND MAGNESIUM CHLORIDE

Epsom salts is the trade name for magnesium sulfate, $\text{MgSO}_4 \cdot 7\text{H}_2\text{O}$. It is used in pharmacy and to a small extent as a mordant in dyeing. In 1939, 47,700 tons were made at an average value of \$29.50 per ton. Most Epsom salts are made at present from

impure salt brines.⁽⁴⁾ These brines are first treated to remove the bromine, then to remove traces of iron, and then are evaporated to precipitate as much sodium chloride as possible. The salt is crystallized out, and the magnesium and calcium chlorides remain in the mother liquor. This mother liquor is concentrated in evaporators under such circumstances as to form the double salt, *tachydrite*. This salt has the composition $2\text{MgCl}_2 \cdot \text{CaCl}_2 \cdot 12\text{H}_2\text{O}$. The brine being evaporated is richer in calcium chloride than in magnesium chloride, but tachydrite is richer in magnesium chloride than in calcium chloride. Consequently, the precipitation of tachydrite depletes the mother liquor with respect to MgCl_2 until it has been reduced to a ratio of MgCl_2 to CaCl_2 of 1:10. The tachydrite is dissolved in hot water, and the solution is cooled in continuous crystallizers. This produces crystals of substantially pure $\text{MgCl}_2 \cdot 6\text{H}_2\text{O}$. The mother liquor from these filters is returned to the tachydrite evaporators. Such small demands as there are for commercial magnesium chloride are supplied by the product of these tachydrite crystallizers, but by far the largest amount of the MgCl_2 so produced is used for the manufacture of metallic magnesium.

The mother liquor from which the tachydrite crystals separate is then treated with lime to precipitate the magnesium as $\text{Mg}(\text{OH})_2$. A very small amount of this $\text{Mg}(\text{OH})_2$ is used for the removal of iron in the initial purification of the brine. The rest is treated with sulfuric acid, and the solution is crystallized in vacuum crystallizers to give commercial Epsom salts.

The manufacture of Epsom salts presents one problem which illustrates a condition which the chemical engineer must often meet. To a surprising extent, substances which are perfectly definite chemically and which could be readily analyzed, are purchased, not on the basis of their purity, but on merely secondary considerations. There is no use to which Epsom salts is put in which the form of the crystal is of the slightest significance. Nevertheless, the pharmaceutical trade has always demanded that Epsom salts be furnished in the form of needle-shaped crystals. This has made it impossible to crystallize Epsom salts in any continuous mechanical crystallizer, as a continuous machine produces symmetrical granular crystals instead of needles. This condition is not peculiar to Epsom salts, but is met in many other fields and often presents very trying problems.

ACID PHOSPHATE

Acid phosphate is the name given in the trade to monocalcium phosphate ($\text{Ca}(\text{H}_2\text{PO}_4)_2 \cdot \text{H}_2\text{O}$). It is used only in fertilizers, but in point of tonnage it is the most important single fertilizer material produced in the United States. Its production requires nearly 25 per cent of all the sulfuric acid made. In 1937 approximately 2,306,000 short tons of phosphate rock were used in the manufacture of acid phosphate. Natural phosphate rock is essentially tricalcium phosphate ($\text{Ca}_3(\text{PO}_4)_2$). It is mined in Tennessee, Florida, and Wyoming as hard rock, and is recovered as pebble phosphate from stream beds in Florida by dredging. In 1926 the pebble phosphate was 80 per cent of the total production. The hard rock as mined and the pebble phosphate after washing out fine material both contain fluorides and carbonates.

Chemical Theory.—When tricalcium phosphate is treated with the proper amount of sulfuric acid, the following reaction takes place:

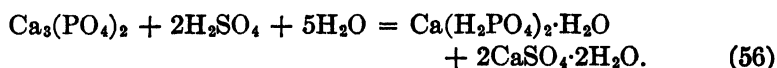

This mixture of monocalcium phosphate and calcium sulfate is known as *superphosphate*. If an excess of acid is used, free phosphoric acid is formed. If too little acid is used, $\text{Ca}_2(\text{HPO}_4)_2$ is formed.

Tricalcium phosphate is so insoluble that if it were used as a fertilizer it would not be attacked by soil acids and, therefore, its phosphorus would not be available for plants. Monocalcium phosphate is only slightly soluble in water and, therefore, is not readily washed out of the soil; but it is attacked by soil acids and, therefore, its phosphorus is available. Dicalcium phosphate is almost as insoluble as tricalcium phosphate and is therefore undesirable. If an excess of sulfuric acid is used and free phosphoric acid is formed, there are two difficulties. If there is free phosphoric acid in the product, it absorbs moisture from the air and thus makes the fertilizer sticky. One essential property of commercial fertilizers is that they must be easily distributed in very small amounts per acre of land, and this is impossible with a lumpy product. Also, the free phosphoric acid in the product is so soluble that it will be washed out of the soil and lost.

Plant.⁽⁵⁾—The crude phosphate rock must be finely ground, usually to pass 100 mesh but sometimes through 200 mesh. Various types of pulverizers are used, but pulverizers of the centrifugal type, such as the Raymond, are especially successful.

A charge of pulverized phosphate rock is weighed into a mixer and a measured amount of sulfuric acid is added. A typical charge is 1,000 pounds of ground rock and 1,000 pounds of 53° sulfuric acid, the exact proportions depending on the composition of the rock and the strength of the acid. Where, as is usually the case, the superphosphate plant operates its own sulfuric-acid plant, this is chamber acid. The charge is stirred vigorously for one to a few minutes and is dumped while still fluid or semisolid into a brick-lined or concrete pit, called a *den*. It stays in the den for some hours to permit the reaction to be nearly completed. During the mixing and the reaction in the den, there is liberated hydrofluoric acid, which combines with silica present to form silicon tetrafluoride. Both mixer and den must be well ventilated to remove these compounds of fluorine. The charge is removed from the den by a crane and grab bucket and is placed in storage piles. The charge may be given a preliminary crushing before going into the storage pile to make the pile more uniform. Some last traces of the reaction occur in the storage pile; and to mix the material and to prevent the formation of lumps, it is usually rehandled several times before being taken from storage to be crushed, screened, and sacked.

Concentrated Fertilizers.—If phosphoric acid is substituted for sulfuric acid in equation (56), monocalcium dihydrogen phosphate will be formed as before; but the product will not be diluted with the inert calcium sulfate, and therefore the product will have a higher content of P_2O_5 . Phosphoric acid made by any process may be used, but the proportion of water in the total charge will be about the same as called for by equation (56). This product is sometimes known as *double superphosphate*, but usually as *triple superphosphate*.

Since all balanced plant fertilizers must contain nitrogen, it has been suggested that the ordinary superphosphate be treated with either gaseous or liquid ammonia. While superphosphate contains two replaceable hydrogens for each molecule of monocalcium dihydrogen phosphate, the amount of ammonia that can be added is limited by the fact that neutralization of any con-

siderable proportion of these replaceable hydrogens will result in rendering some of the P_2O_5 unavailable by the standard tests applied to phosphate fertilizers. The maximum amount of ammonia that can be added to the triple superphosphate is somewhat under 5 per cent. This material, known as *ammoniated superphosphate*, is made to some extent.

In recent years the content of available P_2O_5 in standard superphosphate has risen from 16 to the present figure of approximately 20 per cent. Triple superphosphate is now manufactured with 45 to 48 per cent available P_2O_5 . The Tennessee Valley Authority is experimenting with a material called *metaphosphate*,⁽⁶⁾ which is made by treating phosphate rock directly with P_2O_5 , made by the combustion of phosphorus, in a shaft furnace. This material contains about 60 per cent available P_2O_5 . Up to the present time the production and use of metaphosphate is still experimental.

TRISODIUM PHOSPHATE

This compound is often considered to be $Na_3PO_4 \cdot 12H_2O$. The actual salt contains slightly less water than this, and also contains some free caustic. Without implying that any such salt really exists, the composition of commercial trisodium phosphate would be approximately represented by the formula $Na_3PO_4 \cdot \frac{1}{7}NaOH \cdot 10H_2O$. It is widely used in water treatment, in water-softening compounds, soap powders, and cleaners of all sorts. It is usually known in the trade as TSP.

Figure 52 is a flow sheet of the manufacture of TSP from phosphoric acid.⁽⁷⁾ In this process the acid is first neutralized to approximately disodium phosphate with soda ash, and the neutralization is then completed with an excess of caustic. The neutralizing tanks are steel tanks provided with stirrers and steam coils. A batch of mother liquor from a previous operation is drawn into one of these tanks and the calculated amount of soda ash is added. Phosphoric acid is slowly added, with vigorous agitation and heating, until the batch has the approximate composition of Na_2HPO_4 . The carbon dioxide liberated during this process is withdrawn by fans. At the end of the neutralizing process the batch is boiled to free it completely from carbon dioxide, and is then filtered hot to remove precipitated calcium sulfate, iron and aluminum phosphates, and other insoluble mate-

rial. By running the acid into the soda solution the mixture is never sufficiently acid to interfere with the use of iron apparatus.

The filtered hot solution is treated with a strong solution of caustic soda in sufficient amounts to correspond to trisodium

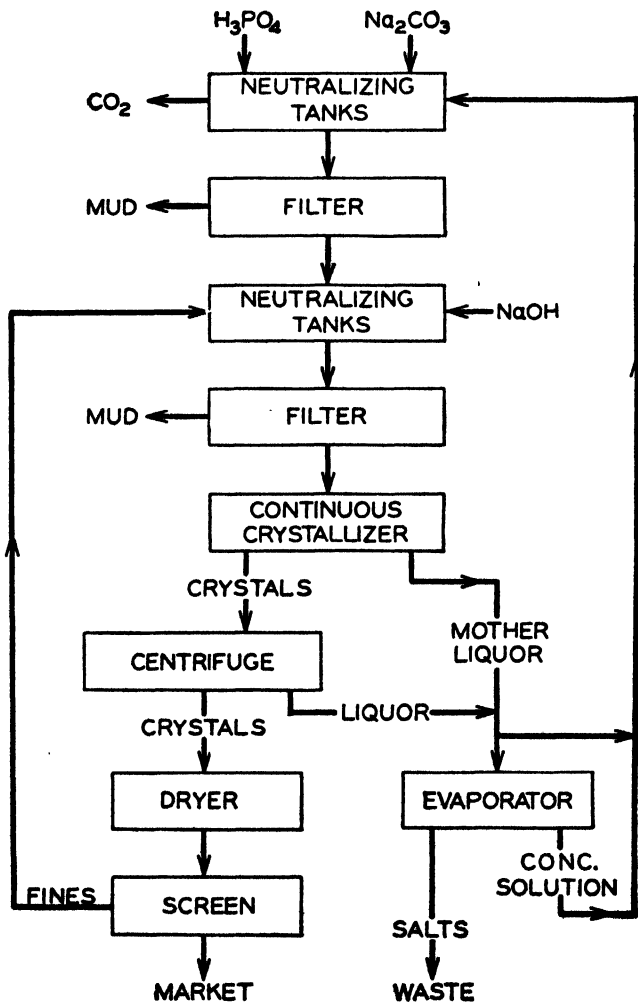

Fig. 52.—Flow sheet of manufacture of trisodium phosphate.

phosphate and to have present a considerable excess of caustic. The ratio of excess caustic must be carefully adjusted, as the alkalinity of the batch has an important bearing on the size of

the crystal produced. The hot alkaline solution is usually filtered again, and is then sent to continuous crystallizers. The crystals from this operation are centrifuged and are then dried and screened. The mother liquor may be returned directly to the dissolving tanks, or it may go to an evaporator for concentration. The amount of evaporation required depends on the balance between water introduced in the phosphoric acid, in the wash water from the filter presses, and in the caustic solution on one hand; and the water leaving as water of crystallization and removed in the driers on the other hand. When using concentrated phosphoric acid, it is possible to adjust this balance so that no evaporation is necessary. If phosphoric acid is made by the treatment of bones or phosphate rock with sulfuric acid, the resulting dilute phosphoric acid is used directly for the manufacture of TSP, and, in this case, the mother liquors must be concentrated. During the concentration there is a slight precipitation of sodium sulfate; and if the carbon dioxide has not been thoroughly boiled out in the first neutralization, some sodium carbonate will also precipitate. With care in the selection of the raw materials it is possible to keep the solution sufficiently pure so that it will rarely be necessary to discard the mother liquors because of accumulated impurities.

The crystallization of TSP must be carefully controlled to give the proper distribution of sizes. A wide range of crystal sizes in the product results in a material with a small percentage of voids, and such a material will usually cake in moist, warm weather. The most desirable product is uniform coarse crystals. The production of such material is not practical; in the first place, because it requires very slow cooling with consequent decrease in the capacity of the crystallizer; and secondly, because in all cases TSP must be put into solution before it is used, and large crystals dissolve much more slowly than fine ones. This second point is especially important in package cleaners and softeners for domestic use. A uniform fine crystal is desirable from the standpoint of rapid solution but is subject to caking, though not as badly as a mixture of sizes. The result of these considerations is that each manufacturer of cleaners has rather rigid size specifications for TSP, and if the range of sizes produced in the crystallizer does not meet these specifications, the oversize and undersize must be redissolved in the plant solutions and recrystallized.

This sometimes represents a considerable item in the cost of the finished product.

POTASSIUM SALTS

Originally the word *potash* meant a crude mixture of potassium hydroxide and potassium carbonate, obtained by leaching hardwood ashes. The word potash is still sometimes used strictly for this particular material, sometimes to mean commercial solutions of KOH, but generally the word potash is loosely used to cover any potassium salt or any material in which K_2O is the important constituent.

About 80 per cent of all the potassium salts produced is used as fertilizer. The remainder goes into the manufacture of a wide variety of miscellaneous chemicals. For fertilizer purposes the acid radical of potash salts is of secondary importance, and hence prices and statistics are based only on the K_2O content. Prices are quoted in terms of a "unit" of K_2O . A unit is 1 per cent of K_2O per ton, or 20 pounds of K_2O . In 1939 the U. S. production of potash was 366,300 short tons of K_2O , with an average value of \$0.328 per unit.

Before the First World War, practically the entire potash supply of the world was produced in Germany.⁽⁸⁾ Prices in the United States were about 50 cents a unit. With the beginning of the World War prices rose rapidly, and finally reached a level of about \$4.50 a unit in 1917. The result was not only an incentive to manufacture potash salts from all kinds of materials, but a willingness on the part of buyers to accept low-grade potash salts.

During the period of the war, a large number of plants sprang up in the United States, making potash from a wide variety of materials. Potash was recovered from wood ashes, from blast furnace and cement mill flue dust, from wool washings, from molasses slop, from tobacco stems, from kelp, and from salt lakes and saline deposits in Nebraska, Utah, and California. The first production was reached by simply evaporating dilute brines from shallow lakes in western Nebraska. This gave a product of about 22 per cent K_2O . Because of the high prices and large profits, practically all of the earnings were put into expansion, instead of into research. As a result, the fall of prices to their normal level at the end of the war left most of these plants

unable to produce high-grade material at a reasonable cost. Of the 125 plants which reported production in 1918, only one large plant has survived.

Between 1920 and 1930 the existence of extensive deposits of potassium salts in western Texas and eastern New Mexico was discovered.⁽⁹⁾ Since that time two large producers have begun to operate on this material. The result is that at the present time, one of the producers surviving from the First World War and these two produce nearly all of the potassium salts used both for fertilizers and for technical purposes in the United States.

German and French Potash.—The original source of these salts is the evaporation of sea water.* The most extensive deposits in the world are in Stassfurt, Germany, and in Alsace-Lorraine. The principal salt in the German deposits is carnallite ($MgCl_2 \cdot KCl \cdot 6H_2O$) which contains 26 per cent K_2O . The deposits actually consist of about 55 per cent carnallite, 25 per cent sodium chloride, and 15 per cent kieserite ($MgSO_4 \cdot H_2O$).⁽¹¹⁾ The principal salt in the Alsatian deposits is sylvinit, a mixture of potassium and sodium chlorides.

The recovery of potassium chloride from carnallite by fractional crystallization is complicated by the presence of other salts in the deposit. In general, the process consists in extracting the crushed raw material with hot mother liquor, settling to remove insoluble material, and then cooling, which separates about 80 per cent of the potassium chloride. A portion of the mother liquor from this crystallization, together with wash water, is used to extract the next batch of salt. The remaining mother liquor is evaporated, and when this is cooled, practically all the remaining potash separates as carnallite. This is added to the next batch of raw material. The final liquor, which is discarded, contains principally magnesium chloride.

Searles Lake Process.—One large producer of potash in this country operates at Searles Lake, California.^(10,11,12) Searles Lake is a bed of solid salt of very complex composition. The interstices between the crystals are filled nearly to the surface of the deposit with a saturated brine which contains K, Na, Cl, CO_3 , B_4O_7 , PO_4 , and other ions in small amounts.

This brine is pumped to the plant, mixed with end liquors from the process, and concentrated in triple-effect evaporators,

* See p. 9.

using countercurrent feed. Each effect produces large amounts of sodium chloride and burkeite ($\text{Na}_2\text{CO}_3 \cdot 2\text{Na}_2\text{SO}_4$). Salts from each effect are pumped to a combination settler in which they are washed with liquors successively leaner in potash, and then filtered on a rotary continuous filter. Mother liquors from the settler are returned to the evaporators. The process is so operated that the solution leaving the first effect is saturated with respect to potassium chloride.

At this point the liquor is nearly saturated with respect to borax, and slow cooling would result in a crop of crystals of both potassium chloride and borax. Even small amounts of borax are not permissible in potash salts that are to be used for fertilizers. It was discovered, however, that if the solution were cooled very quickly only potassium chloride would separate from the mother liquors (which are supersaturated with respect to borax). Borax crystals come out much more slowly. In practice this is accomplished by cooling the solution from the evaporator in vacuum crystallizers to about 100°F . Potassium chloride produced in these crystallizers is centrifuged and dried.

The mother liquor from the potash crystallizers is cooled in a second set of vacuum crystallizers to 75°F ., using direct expansion ammonia to condense the vapor and produce the vacuum. The product of these crystallizers is crude borax, which is separated on rotary continuous vacuum filters. The mother liquor from the borax crystallization is returned to the evaporators and is mixed with the incoming brine. This makes possible a control of the carbonate-sulfate ratio in the feed to the evaporators. This ratio is so adjusted that evaporation precipitates burkeite and not glaserite, $\text{K}_2\text{Na}(\text{SO}_4)_2$. Glaserite is relatively insoluble, and many projects for recovering potash from such brines as this have failed because of the separation of this salt.

The crude borax from the borax crystallizers is dissolved in hot borax mother-liquor, filtered, and crystallized again in vacuum crystallizers. This product, after centrifuging and drying, is purified borax of commerce. Recently this plant has installed a process for converting burkeite to soda ash and sodium sulfate.

New Mexico Processes.—Two of the three large American producers are located at Carlsbad, N. M. The deposit is a bed of sylvinite, a mixture of sodium and potassium chlorides. The

two companies use quite different methods for the separation of these two salts, one employing fractional crystallization, the other fractional flotation. The process of fractional crystallization will be discussed at considerable length, not because of the importance of this particular process but because it is representative of a type of salt separation frequently carried out in practice.

The System Sodium Chloride-Potassium Chloride-Water.—

In considering solutions containing two salts, it is necessary to know, not only the effect of temperature upon the single solubilities (*i.e.*, the solubility of each salt if it alone were present), but also the effect of temperature on mutual solubilities (the composition of a solution saturated with respect to both) and the intermediate solubilities (composition of solutions containing both salts, but saturated with respect to only one). Table XXIV and Fig. 53 present such data for the system, sodium chloride-potassium chloride-water.⁽¹³⁾

TABLE XXIV.—MUTUAL SOLUBILITIES OF POTASSIUM CHLORIDE AND SODIUM CHLORIDE IN PARTS SOLID PER HUNDRED PARTS WATER

Temperature, degrees centigrade	KCl alone	NaCl alone	Mixed solutions	
			KCl	NaCl
0	28.1	35.6	10.3	31.8
20	34.3	35.8	14.8	30.4
40	40.2	36.3	19.6	29.3
60	45.5	37.0	24.6	28.4
80	50.6	37.9	30.0	27.7
100	55.5	38.9	35.3	27.5
110	(57.9)*	(39.4)*	38.2	27.5

* Interpolated values.

In Fig. 53 temperature is plotted on the axis OO' , solubility of sodium chloride on the axis OA , and the solubility of potassium chloride on the axis OB . The line AD then shows the change in solubility of sodium chloride alone with temperature. The line BF is the corresponding line for potassium chloride. It will be noted that these are the solubility curves as ordinarily drawn for single salts. Considering the section $ACBO$, which presents data for 0°C ., the line AC represents the decrease in solubility of sodium chloride in the presence of increasing amounts of potas-

sium chloride. The line BC represents the decrease in solubility of potassium chloride with increase in sodium chloride, while the point C represents the composition of a solution saturated at $0^{\circ}\text{C}.$ with respect to both salts. By taking other sections at different temperatures, the system may be presented as a solid model whose boundary surfaces represent solutions saturated

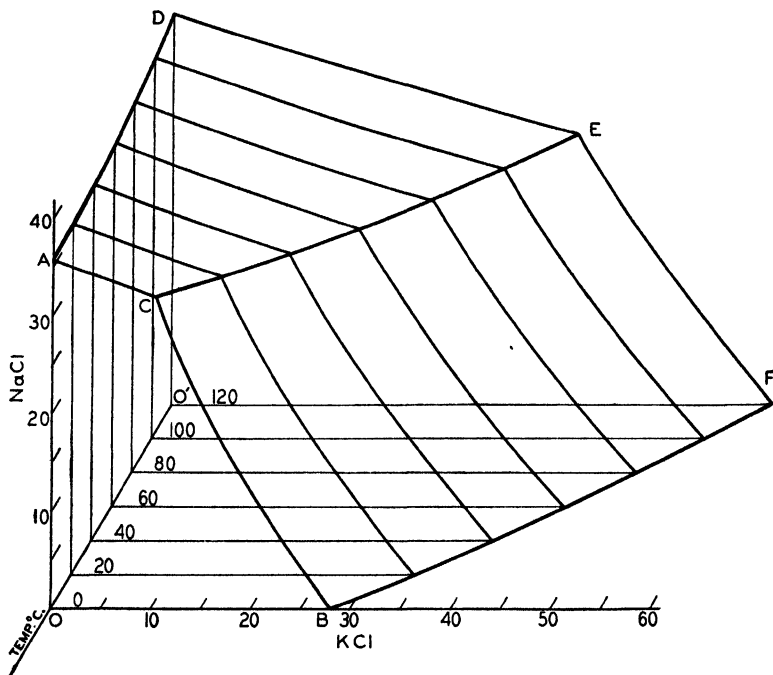

FIG. 53.—Mutual solubilities of sodium chloride and potassium chloride.

with respect to one salt, whose edge CE represents solutions saturated with respect to both salts, and whose interior represents the range of unsaturated solutions. No solution is stable whose composition falls outside this solid model. Solutions lying on the surface $ADEC$ are saturated with respect to sodium chloride only, while those on the surface $BCEF$ are saturated with respect to potassium chloride only.

In considering the application of Fig. 53 to the extraction of potassium chloride from mixed salts, it will be assumed that the process operates between 110 and $20^{\circ}\text{C}.$ For the calculations it will be necessary, therefore, only to know the data for these two

temperatures. Figure 54 shows a projection of the sections at 20 and 100°C. on a plane perpendicular to the temperature axis. In this form the data are more convenient for calculations.

A material containing 40 per cent potassium chloride and 60 per cent of sodium chloride is fairly representative of the sylvinite mined in New Mexico. The steps in extracting potassium chloride will be as follows:

(1) Saturation of fresh water with both salts at 110°C. and separating the resulting solution from the undissolved material.

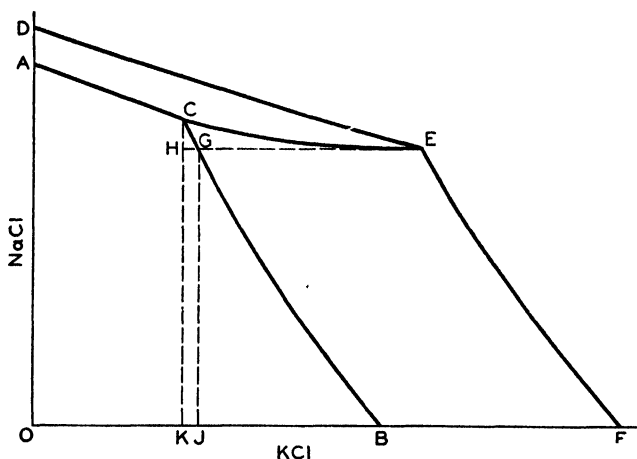

FIG. 54.—Mutual solubilities of sodium chloride and potassium chloride at 110 and 20°C.

(2) Cooling the clear solution to 20°C. and separating the resulting mother liquor from the crystals that form on cooling. (3) Reheating this mother liquor to 110°C. and resaturating with a fresh quantity of raw material. Steps 2 and 3 may then be repeated indefinitely.

If 100 pounds of water be taken as the basis for the calculations, according to Table XXIV this will dissolve 38.2 pounds of KCl and 27.5 pounds of NaCl at 110°C. To furnish the 38.2 pounds of KCl, there will be required 95.5 pounds of raw material. This will contain 57.3 pounds of NaCl, but the 100 pounds of water taken will only dissolve 27.5 pounds of NaCl, and there would therefore be left as a residue 29.8 pounds of undissolved NaCl. The conditions will then be

	H ₂ O, pounds	KCl, pounds	NaCl, pounds
Initial charge.....	100	38.2	57.3
Solution 1.....	100	38.2	27.5
Residue.....	29.8

The composition of the solution so obtained corresponds to point *E* on both Figs. 53 and 54.

Solution 1 will now be cooled to 20°C., crystallizing out KCl and yielding solution 2. During this cooling to 20° the NaCl content of the solution cannot increase, because no solid NaCl is present. Therefore, the path of the solution on cooling is represented in Fig. 54 by the line *EG* (and not by the line *EC*, which is the line marking the boundary between the potassium chloride and sodium chloride planes). It must be remembered that this line *EG* lies on the outer surface of the solid model. The coordinates at the point *G* may be read from Fig. 54, and are found to be 16.3 pounds of KCl and 27.5 pounds of NaCl. This process is shown in the following table:

	H ₂ O, pounds	KCl, pounds	NaCl, pounds
Solution 1.....	100	38.2	27.5
Solution 2.....	100	16.3	27.5
Yield.....	...	21.9

Hence, the yield on cooling from *E* to *G* has been 21.9 pounds of KCl.

If solution 2 is reheated to 110°C. and used to leach a fresh batch of ore, enough of the ore should be taken to contain 21.9 pounds of potassium chloride, in which case the composition of the solution will return to point *E*. It is impossible to state the exact path by which the solution goes from *G* to *E*. This is probably not along the line *GE* because some sodium chloride should dissolve during the early stages of leaching. Sodium chloride that so dissolves, however, must have crystallized out when final equilibrium is reached.

Recovery of Potassium Chloride. Crystallization Process.—The sylvinite is mined by ordinary underground methods, is crushed, and charged into large leaching tanks where it is leached with mother liquors from a previous step in the cycle.^(14,15) This operation is carried out as near the boiling point as possible, in this case at 110°C. The solution is filtered and charged hot into vacuum crystallizers where it is cooled by flash evaporation in a vacuum. Since this removes water, it would tend to precipitate both potassium and sodium chlorides; but enough water is fed to the crystallizer to correspond to the amount flashed off, so that no sodium chloride separates. The cooled solution is filtered on a rotary vacuum filter, which removes the potassium chloride crystals. These crystals are washed and dried on the filter. The mother liquor is reheated and used to leach the next batch of salt. As shown in the previous problem this mother liquor, after coming into equilibrium with the mixed salt at 110°, should dissolve only potassium chloride, leaving the sodium chloride in the ore undissolved to be discarded after leaching.

Flotation Process.—The other large operator at Carlsbad uses a flotation process. Sylvinite is not a double salt, nor a true mixed crystal in the sense of an intermolecular dispersion of the two compounds. If the ore is crushed to about 40 mesh, the sodium and potassium chlorides are all in separate crystal fragments. A flotation agent has been found that permits carrying off the sodium chloride in the froth, while the potassium chloride is discharged from the bottom of the flotation cell.

BORAX

Borax is $\text{Na}_2\text{B}_4\text{O}_7 \cdot 10\text{H}_2\text{O}$. It is used in the manufacture of vitreous enamels and borosilicate glasses, as a preservative for some food products, and in cleansing and water-softening compounds. Approximately 90 per cent of the world's production of borax is made in the United States by two companies; one operating at Searles Lake by the process described above, and the other on borax minerals. In 1937 the production of borax was 126,000 tons, with an average value of \$27.00 per ton.

The latter company has, in the past, worked mainly colemanite ($\text{Ca}_2\text{B}_6\text{O}_{11} \cdot 5\text{H}_2\text{O}$).⁽¹⁶⁾ The crude ore was crushed, calcined, and digested with a dilute solution of sodium carbonate. This precipitated calcium carbonate and yielded a solution of borax and

other soluble salts. Borax crystallized from this solution on slow cooling.

Recently a large deposit of a new sodium borate called *rasorite* ($\text{Na}_7\text{B}_4\text{O}_{17}\cdot 4\text{H}_2\text{O}$) has been discovered in California. This has replaced colemanite as their raw material.

CALCIUM CHLORIDE

The principal uses of calcium chloride are in brines for refrigerating, for dustproofing dirt roads, and for hardening concrete. In 1939 there were produced 215,000 tons of material ranging from 73 to 80 per cent CaCl_2 , with an average value of \$18.90 per ton.

Calcium chloride is manufactured in the United States from two principal sources. One is the waste liquors from the Solvay process, and the other is from impure natural brines, both of about equal importance.

Solvay waste liquors are practically free from magnesium chloride. Natural brines always contain a mixture of calcium and magnesium chlorides in the ratio of 1 part of magnesium chloride to 3 to 5 parts of calcium chloride. Magnesium chloride is undesirable in calcium chloride for two reasons. When the brines are used for refrigeration, the presence of magnesium chloride causes corrosion. The presence of magnesium chloride lowers the melting point of the mixture and makes it difficult to secure a solid product. One method for removing magnesium chloride has been described on page 200. Another method is to remove the magnesium chloride as magnesium hydroxide by treatment with lime. The precipitate is allowed to settle or is removed by Dorr thickeners.

Natural brines after purification, or Solvay waste liquors as they come from the plant, are concentrated first in multiple-effect evaporators, and finally in a single-effect finishing pan until they reach 75 per cent solids. Both solutions contain sodium chloride, but this is only slightly soluble in strong calcium-chloride solutions and, therefore, separates in the earlier stages of evaporation. The 75 per cent solution is run into drums or is run over a flaker. The flakes are usually passed through a direct oil-fired rotary calciner, which gives a thin coating of anhydrous calcium chloride, which is less hygroscopic. The flakes so treated are superior from the standpoint of storing and handling.

BROMINE

The production of bromine in 1939 was 37,900,000 pounds, having a value of 20 cents per pound. Formerly the only major uses for bromine and bromides were in photography, medicine, and special chemicals. Recently, large amounts have been required in the manufacture of *ethyl fluid* for anti-knock gasoline. Ethyl fluid contains lead tetraethyl, $\text{Pb}(\text{C}_2\text{H}_5)_4$. When gasoline containing this compound is burned, the lead appears as lead oxide, which would coat cylinder walls and valves. By the addition of bromine to the ethyl fluid in the form of ethylene dibromide ($\text{C}_2\text{H}_2\text{Br}_2$), the lead is converted to lead bromide, which is volatile at cylinder temperatures and therefore leaves the cylinder with the exhaust. Most of the bromine produced is converted to ethylene dibromide for this purpose.

Formerly, most of the bromine produced in the United States was recovered from impure natural brines, mainly those of the Saginaw Valley of Central Michigan; but today the bulk of the production is from sea water.⁽¹⁷⁾ The Michigan natural brine contains about 1,300 parts per million of bromine, and from this about 95 per cent of the bromine is recovered. Sea water contains about 65 to 70 parts per million of bromine, or about the concentration in the effluent from the earlier process. The low concentration of bromine in sea water makes it necessary to treat extremely large quantities. It is important that the water from which the bromine has been extracted does not return to the intake. Consequently, plants operating on sea water are so located that they have their intake in the ocean and discharge their effluent into a river which, in turn, discharges many miles away from the intake.

A flow sheet for this process is shown in Fig. 55. The sea water pumped to the plant is treated first with sulfuric acid to adjust the pH of the brine to about 3.5. Chlorine is then added in an amount equivalent to the bromine content of the sea water. The reaction is

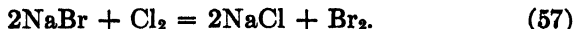

The brine is passed into blowing-out towers in countercurrent with air. This vaporizes the bromine, which is recovered by passing the air-bromine stream through absorption towers over

which soda-ash solution is circulated. The absorption tower consists of nine chambers through which the air passes in series. The soda ash solution is recirculated over each chamber, and is

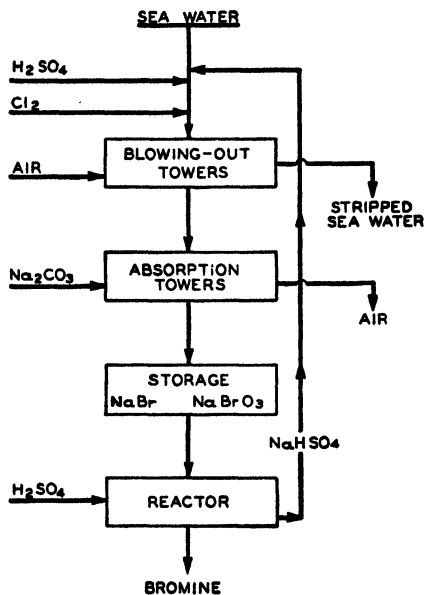
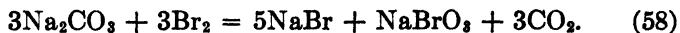

FIG. 55.—Flow sheet for production of bromine from sea water.

moved countercurrent to the air in batches. In the absorption towers the following reaction takes place:



The relatively concentrated solution of sodium bromide and sodium bromate can be treated with sulfuric acid to recover the bromine and yield a solution of sodium acid sulfate. This solution of sodium acid sulfate is added to the sea water, replacing part of the sulfuric acid that would otherwise be required.

The acidification of the brine to a definite pH is the essential part of the process. Figure 56 shows as abscissas the pH of sea water, and as ordinates the per cent of the bromine that can be recovered by passing air through the sea water after adding chlorine. At a high pH, bromine liberated would be in the form of HBr and HOBr , and would simply react with other components of the sea water to lower the pH. The pH could be lowered by

the use of a sufficient excess of chlorine, which would dissolve to form HCl and HOCl. It is more economical to accomplish this lowering of the pH by the addition of H₂SO₄.

The process used for recovering bromine from the richer Michigan brines does not differ basically in principle from the process described above, but 95 per cent recovery can be obtained without the acidification step.

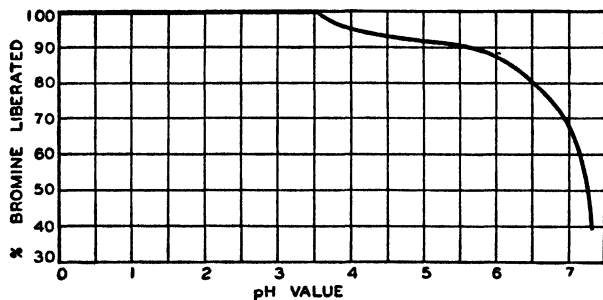

FIG. 56.—Effect of pH on bromine liberation.

Most of the *iodine* used in the United States is made by an entirely analogous process from brines from deep oil wells near Long Beach, Calif.

CARBON DIOXIDE

Carbon dioxide is used principally in the manufacture of carbonated beverages and as the working fluid in refrigerating machines. Compressed solid carbon dioxide has come on the market under the name of *dry ice*.⁽¹⁸⁾ Some carbon dioxide is recovered from fermentation processes, some is obtained by treating dolomite with acid, and some is recovered as a by-product in the Solvay process; but much is made from the combustion of coke. The first three processes give a nearly pure gas, which may be scrubbed with water and then liquefied directly. The last process is considerably more complicated.

The combustion of coke cannot be made to produce a gas containing over 19 per cent carbon dioxide, and even this figure is reached with some difficulty. From the line of reasoning advanced in discussing liquid chlorine, it is obvious that this gas must be concentrated before compression. This is done by taking advantage of the following reversible reaction:



In practice this reaction is never carried to completion in either direction. The solution throughout the process contains both sodium carbonate and bicarbonate, richer in the former constituent in the absorption end of the system and richer in bicarbonate in the later stages.

Chemical Theory.—The solubility of carbon dioxide in such a liquid will obviously depend on the ratio of carbonate to bicarbonate, the total amount of salt in the solution, the temperature, and the partial pressure of carbon dioxide in the gas to be treated. The relation between these variables is as follows:⁽¹⁹⁾

$$\frac{X^2 C^{1.29}}{SP(1 - X)(185 - t)} = 10, \quad (60)$$

where X = fraction of sodium in form of bicarbonate.

$1 - X$ = fraction of sodium in form of carbonate.

S = solubility of carbon dioxide in water at the given temperature and 1 atmosphere partial pressure, expressed as gram molecules carbon dioxide per liter of water.

P = partial pressure of carbon dioxide in gas phase in atmospheres.

C = concentration of sodium in gram-atoms per liter.

t = temperature in degrees centigrade.

The solubility of carbon dioxide in water when the partial pressure of carbon dioxide is 760 millimeters is as follows:

TABLE XXV.—SOLUBILITY OF CARBON DIOXIDE IN WATER

Degrees Fahrenheit	S
32	0.0765
50	0.0533
68	0.0391
86	0.0297
104	0.0237
122	0.0195
140	0.0160
160	0.0130
180	0.0100
200	0.0075
220	0.0055

Plant.—Figure 57 is a flow sheet of this process. Coke is burned under a boiler in a specially designed setting. A large

next to the lye boiler, which is a standard fire-tube boiler, in which the strong lye loses much of its carbon dioxide and at the same time the gas is still further cooled. This boiler contains steam coils also as an additional source of heat.

The flue gas, after traversing the lye boiler, is scrubbed in a sheet-steel tower packed with limestone, down which warm water is showered and up through which the gas is passed. This absorbs sulfur dioxide and washes out dirt. The gas is circulated through the system by a blower of the cycloidal type. This is usually placed after the scrubbing tower, so that the preceding equipment is under a slight vacuum, and the rest of the system is under pressure. This back pressure is due to frictional resistance, and amounts to several inches of mercury.

The purified flue gas is passed up through an absorption tower, which consists of a steel shell packed with coke. The shell is 5 to 15 feet in diameter and 50 to 100 feet high, according to the capacity of the plant. Because of the great weight of packing in such a tall tower, intermediate distributing plates are inserted to carry the packing. Because of the large tower diameter, these plates are also necessary to secure uniform distribution of the liquid. The liquid that passes down this tower is the lye solution that has had its bicarbonate content lowered by boiling off carbon dioxide in the lye boiler. This solution, after leaving the lye boiler, is cooled in a heat interchanger, before it enters the tower. Waste flue gas leaving the top of the absorption tower still contains 7 to 17 per cent of carbon dioxide. This corresponds to a recovery of only one-third to two-thirds of the carbon dioxide obtained from the coke.

The strong lye from the bottom of the absorbing tower is pumped through the heat interchanger in which the hot, weak lye coming from the lye boiler is cooled. The strong lye then passes through a second heat interchanger where it is further heated by the mixture of carbon dioxide and steam driven off from the lye boiler. This condenses some of the steam, and leaves the mixture somewhat richer in carbon dioxide. From this heat interchanger, the strong lye goes to the lye boiler and its cycle is thus completed.

The mixture of carbon dioxide and steam driven off in the lye boiler first goes through the heat interchanger mentioned above, and then through further cooling coils in which it is cooled

by cold water. Since all the steam evolved in the lye boiler has come out of the solution, it is obvious that the condensation from these two coolers must be returned to the weak lye in order to keep its volume and composition constant.

The cool, nearly dry, carbon dioxide is compressed in a two- or three-stage compressor to about 1,300 pounds. This compressor is so operated that the back pressure on the cooling coils is practically atmospheric. A reduced pressure in these coils would result in a higher concentration of water vapor in the gas entering the compressor. The compressed gas passes through another set of coils, cooled with water, where its temperature is reduced. The first section of these coils condenses water, which is removed by a trap. The rest of these coils reduce the temperature of the carbon dioxide enough so that it liquefies under the pressure existing in this end of the system. Liquid carbon dioxide is drawn directly into steel bottles or other containers.

References

- (1) WALKER, G. E., *Chem. Met. Eng.*, **31**, 776-780 (1924).
- (2) LAUTER, C. J., *Ind. Eng. Chem.*, **25**, 953-958 (1933).
- (3) DE BLOIS, W. H., *Can. Min. J.*, **51**, 1057-1059 (1930).
- (4) GANN, J. A., *Trans. Am. Inst. Chem. Eng.*, **24**, 212-213 (1930).
- (5) MCBRIDE, R. S., *Chem. Met. Eng.*, **47**, 4-9 (1940).
- (6) CURTIS, H. A., COPSON, R. L., ABRAMS, A. J., and JUNKINS, J. N., *Chem. Met. Eng.*, **45**, 318-322 (1938).
- (7) SNELL, F. D., *Ind. Eng. Chem.*, **23**, 470-474 (1931).
- (8) LODGE, F. S., *Ind. Eng. Chem.*, **30**, 878-882 (1938).
- (9) SMITH, H. I., *Ind. Eng. Chem.*, **30**, 854-860 (1938).
- (10) GALE, W. A., *Ind. Eng. Chem.*, **30**, 867-871 (1938).
- (11) MUMFORD, R. W., *Ind. Eng. Chem.*, **30**, 872-878 (1938).
- (12) MANNING, P. D. V., *Chem. Met. Eng.*, **36**, 268-272 (1929).
- (13) CORNEC, E., and KROMBACH, H., *Ann. Chim.*, [10], **18**, 5-31 (1932).
- (14) KIRKPATRICK, S. D., *Chem. Met. Eng.*, **45**, 488-492 (1938).
- (15) CRAMER, T. M., *Ind. Eng. Chem.*, **30**, 865-867 (1938).
- (16) GLAZE, H. L., *Chem. Met. Eng.*, **37**, 296-298 (1930).
- (17) STEWART, L. C., *Ind. Eng. Chem.*, **26**, 361-369 (1934).
- (18) KILLEFER, D. H., *Ind. Eng. Chem.*, **19**, 192-195 (1927).
- (19) HARTE, C. R., JR., BAKER, E. M., and PURCELL, H. H., *Ind. Eng. Chem.*, **25**, 528-531 (1933).

Problems

1. A steel mill produces a waste pickle liquor containing 6 per cent Fe in solution as ferrous iron, and 1.5 per cent free H_2SO_4 . Copperas is to be made by crystallizing between 55° and $20^\circ C$. The solubility of $FeSO_4$

is 53.15 parts at 55° and 26.60 parts at 20°, both as parts FeSO_4 per 100 parts H_2O . The plant is to make 12 tons of salt per 24 hours. How much water is to be evaporated per hour?

2. Solid Glauber's salt crystals are harvested from a lake in Saskatchewan. These crystals are first melted in their water of crystallization at 50°C., and 5 per cent of this water is evaporated in the process. The remaining solution is evaporated in vacuum evaporators. The plant is to produce 50 tons of anhydrous Na_2SO_4 per day. What is the weight of dry anhydrous salt to be produced in the evaporators?

3. The mother liquor from a TSP crystallizer contains 20 parts Na_3PO_4 per 100 parts water. It is used in a batch consisting of mother liquor, dry soda ash, and 80 per cent phosphoric acid. This is then neutralized to TSP by adding a 67 per cent solution of NaOH . What are the amounts of mother liquor, soda ash, acid, and caustic solution used per ton of finished solution, if this finished solution contains 55 parts Na_3PO_4 per 100 parts water?

4. Sylvinite containing 38 per cent KCl and 62 per cent NaCl is to be separated into KCl and NaCl by fractional crystallization.

- a. If the extraction is carried out at 75°C., how many pounds of sylvinite should be taken per 1,000 pounds of water, in order that the solution will become saturated with KCl at this temperature and none of the KCl will remain undissolved?
 - b. How much NaCl will remain undissolved?
 - c. If the solution is now cooled to 0°C., how many pounds of KCl will be crystallized from the solution?
 - d. What will be the weight and composition of the solution after this cooling?
 - e. If the mother liquor from the KCl crystallization is reheated and brought in contact with more ore at 75°C., how many pounds of ore should be taken in order that the KCl will be completely extracted from it and so that the solution will be saturated with respect to KCl ?
5. A solution at 0°C. contains 1,000 pounds of water, 100 pounds of NaCl , and 50 pounds of KCl . This solution is heated to 100°C. and at 100°C. water is evaporated until the solution becomes saturated with respect to one salt.
- a. Which salt is this?
 - b. How many pounds of water have been evaporated?
 - c. What is the weight and composition of the solution?
 - d. Evaporation is now continued at 100°C. until the solution is saturated with respect to both salts. When this point has been reached, which salt and how much of it has been precipitated? What is the weight and composition of the remaining solution?
 - e. Indicate on a diagram the path of the solution as it changes composition and temperature during the above steps of heating and evaporation.
6. A lye in a carbon dioxide plant contains 1.75 gram-atoms sodium per liter. This leaves the bottom of the absorption tower in equilibrium with gas containing 12 per cent CO_2 at 77°F. and 1 atmosphere pressure. What is the composition of this liquor?

APPENDIX

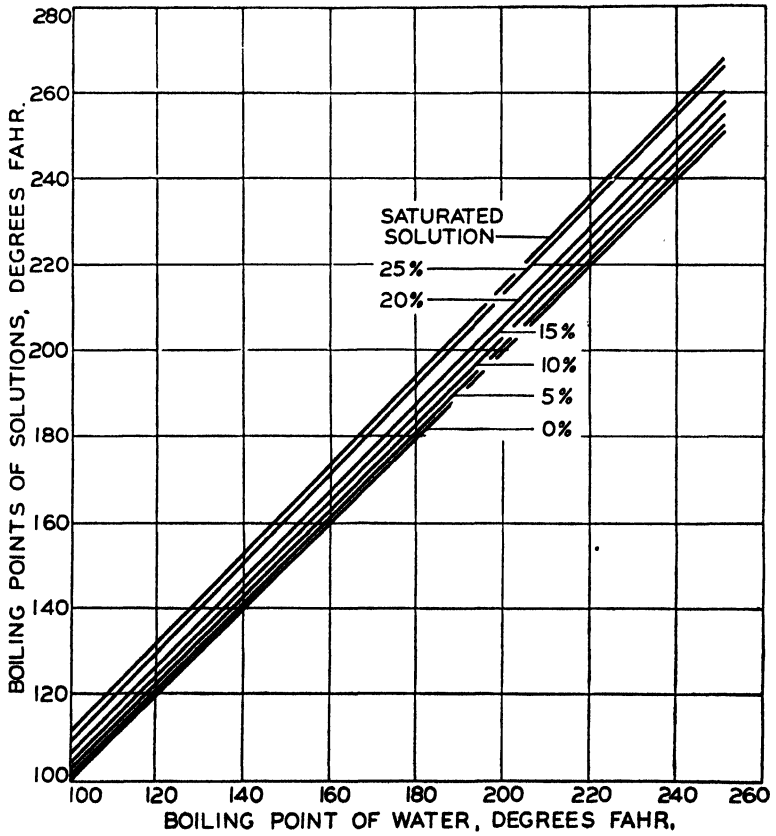

Fig. 58.—Boiling points of salt solutions.

TABLE XXVI.—PROPERTIES OF SATURATED STEAM

Temperature, degrees Fahrenheit	Temperature, degrees Centigrade	Absolute pressure, pounds per square inch	Latent heat of evaporation, B.t.u. per pound	Specific volume, cubic feet per pound	Density of liquid water	Viscosity of liquid water
32	0.00	0.0886	1,073.4	3,294	62.42	1.794
35	1.67	0.0999	1,071.7	2,938	62.43	1.692
40	4.44	0.1217	1,068.9	2,438	62.43	1.546
45	7.22	0.1475	1,066.1	2,033	62.42	1.420
50	10.00	0.1780	1,063.3	1,702	62.42	1.310
55	12.78	0.2140	1,060.6	1,430	62.40	1.213
60	15.56	0.2562	1,057.8	1,208	62.37	1.129
65	18.33	0.3054	1,055.0	1,024	62.34	1.052
70	21.11	0.3626	1,052.3	871	62.30	0.982
75	23.89	0.4288	1,049.5	743	62.26	0.919
80	26.67	0.505	1,046.7	636.8	62.22	0.862
85	29.44	0.594	1,044.0	545.9	62.17	0.810
90	32.22	0.696	1,041.2	469.3	62.11	0.764
95	35.00	0.813	1,038.4	405.0	62.06	0.721
100	37.78	0.946	1,035.6	350.8	62.00	0.682
105	40.56	1.098	1,032.8	304.7	61.93	0.647
110	43.33	1.271	1,030.0	265.5	61.86	0.616
115	46.11	1.467	1,027.2	231.9	61.79	0.586
120	48.89	1.689	1,024.4	203.1	61.71	0.559
125	51.67	1.938	1,021.6	178.4	61.63	0.535
130	54.44	2.219	1,018.8	157.1	61.55	0.511
135	57.22	2.533	1,016.0	138.7	61.46	0.490
140	60.00	2.885	1,013.1	122.8	61.38	0.470
145	62.78	3.277	1,010.3	109.0	61.29	0.451
150	65.56	3.714	1,007.4	96.9	61.20	0.433
155	68.33	4.199	1,004.5	86.4	61.10	0.417
160	71.11	4.737	1,001.6	77.2	61.00	0.401
165	73.89	5.333	998.7	69.1	60.90	0.386
170	76.67	5.992	995.8	62.0	60.80	0.372
175	79.44	6.714	992.9	55.7	60.69	0.359
180	82.22	7.51	989.9	50.15	60.58	0.347
185	85.00	8.38	986.9	45.25	60.47	0.336
190	87.78	9.34	983.9	40.91	60.36	0.325
195	90.56	10.39	980.9	37.04	60.24	0.315
200	93.33	11.52	977.8	33.60	60.12	0.305
205	96.11	12.77	974.7	30.53	60.00	0.295
210	98.89	14.13	971.6	27.80	59.88	0.287
212	100.00	14.70	970.4	26.79	59.83	0.284
215	101.67	15.60	968.4	25.35	59.76	
220	104.44	17.19	965.2	23.15		
225	107.22	18.91	962.0	21.17		
230	110.00	20.77	958.7	19.39		
235	112.22	22.79	955.4	17.78		
240	115.56	24.97	952.1	16.32		
245	118.33	27.31	948.7	15.01		
250	121.11	29.82	945.3	13.82		
260	126.67	35.42	938.4	11.76		
270	132.22	41.85	931.4	10.06		
280	137.78	49.18	924.3	8.64		
290	143.33	57.55	916.9	7.46		

TABLE XXVI.—PROPERTIES OF SATURATED STEAM.—*Continued*

Temperature, degrees Fahrenheit	Temperature, degrees Centigrade	Absolute pressure, pounds per square inch	Latent heat of evaporation, B.t.u. per pound	Specific volume, cubic feet per pound	Density of liquid water	Viscosity of liquid water
300	148.89	67.00	909.5	6.46		
310	154.44	77.67	901.9	5.62		
320	160.00	89.63	894.2	4.91		
330	165.56	103.0	886.3	4.306		
340	171.11	118.0	878.3	3.787		
350	176.67	134.6	870.1	3.342		
360	182.22	153.0	861.8	2.957		
370	187.78	173.3	853.4	2.627		
380	193.33	195.6	844.8	2.340		
390	198.89	220.2	836.1	2.089		
400	204.44	247.1	827.2	1.872		

TABLE XXVII.—DIMENSIONS OF STANDARD IRON PIPE

Nominal size	Diameter, inches		Transverse area, square inches		Length per square foot	
	Internal	External	Internal	External	Internal surface	External surface
$\frac{1}{8}$	0.269	0.405	0.057	0.129	14.199	9.431
$\frac{1}{4}$	0.364	0.540	0.104	0.229	10.493	7.073
$\frac{3}{8}$	0.493	0.675	0.191	0.358	7.747	5.658
$\frac{1}{2}$	0.622	0.840	0.304	0.554	6.141	4.547
$\frac{3}{4}$	0.824	1.050	0.533	0.866	4.635	3.637
1	1.049	1.315	0.864	1.358	3.641	2.904
$1\frac{1}{4}$	1.380	1.660	1.495	2.164	2.767	2.301
$1\frac{1}{2}$	1.610	1.900	2.036	2.835	2.372	2.010
2	2.067	2.375	3.355	4.430	1.847	1.608
$2\frac{1}{2}$	2.469	2.875	4.788	6.492	1.547	1.328
3	3.068	3.500	7.393	9.621	1.245	1.091
$3\frac{1}{2}$	3.548	4.000	9.886	12.566	1.076	0.954
4	4.026	4.500	12.730	15.904	0.948	0.848
6	6.065	6.625	28.891	34.472	0.629	0.576
8	7.981	8.625	50.027	58.426	0.478	0.442
10	10.020	10.750	78.855	90.763	0.381	0.355
12	12.000	12.750	113.097	127.676	0.318	0.299

TABLE XXVIII.—DENSITY AND SPECIFIC GRAVITY OF SOLUTIONS HEAVIER THAN WATER

Degrees Baumé	Specific gravity	Pounds per gallon	Per cent by weight				
			H ₂ SO ₄ * at 60°F.	HNO ₃ * at 60°F.	HCl* at 60°F.	NaOH at 15°C.	Na ₂ CO ₃ at 15°C.
0°	1.000	8.328					
1	1.007	8.385	1.02	1.40	0.59	0.74
2	1.014	8.445	2.08	2.82	1.20	1.10
3	1.021	8.504	3.13	4.25	1.85	2.03
4	1.028	8.565	4.21	5.69	2.50	2.72
5	1.036	8.625	5.28	7.15	3.15	3.42
6	1.043	8.688	6.37	8.64	3.79	4.12
7	1.051	8.750	7.45	10.17	4.50	4.81
8	1.058	8.814	8.55	11.71	5.20	5.52
9	1.066	8.879	9.66	13.26	5.86	6.27
10	1.074	8.945	10.77	12.86	14.83	6.58	6.95
11	1.082	9.012	11.89	14.13	16.41	7.30	7.70
12	1.090	9.078	13.01	15.41	18.01	8.07	8.43
13	1.099	9.148	14.13	16.72	19.63	8.78	9.18
14	1.107	9.218	15.25	18.04	21.27	9.50	9.94
15	1.115	9.289	16.38	19.36	22.92	10.30	10.67
16	1.124	9.361	17.53	20.69	24.57	11.06	11.48
17	1.133	9.434	18.71	22.04	26.22	11.90	
18	1.142	9.508	19.89	23.42	27.92	12.69	
19	1.151	9.584	21.07	24.82	29.65	13.50	
20	1.160	9.660	22.25	26.24	31.45	14.35	
21	1.169	9.739	23.43	27.67	33.31	15.15	
22	1.179	9.818	24.61	29.07	35.21	16.00	
23	1.189	9.898	25.81	30.49	37.14	16.91	
24	1.198	9.979	27.03	31.94	39.41	17.81	
25	1.208	10.063	28.28	33.42	41.72	18.71	
26	1.219	10.148	29.53	34.94	19.65	
27	1.229	10.233	30.79	36.48	20.60	
28	1.239	10.321	32.05	38.06	21.55	
29	1.250	10.410	33.33	39.66	22.50	
30	1.261	10.501	34.63	41.30	23.50	
31	1.272	10.592	35.93	43.00	24.48	
32	1.283	10.686	37.26	44.78	25.50	
33	1.295	10.781	38.58	46.58	26.58	
34	1.306	10.879	39.92	48.42	27.65	
35	1.318	10.978	41.27	50.32	28.83	
36	1.330	11.079	42.63	52.30	30.00	
37	1.343	11.181	43.99	54.36	31.20	
38	1.355	11.285	45.35	56.52	32.50	
39	1.368	11.392	46.72	58.82	33.73	
40	1.381	11.501	48.10	61.38	35.00	
41	1.394	11.611	49.47	64.20	36.36	
42	1.408	11.724	50.87	67.18	37.65	
43	1.422	11.839	52.26	70.33	39.06	
44	1.436	11.956	53.66	73.67	40.47	
45	1.450	12.076	55.07	77.17	42.02	
46	1.465	12.197	56.48	81.08	43.58	
47	1.480	12.322	57.90	85.70	45.16	
48	1.495	12.449	59.32	91.35	46.73	
49	1.510	12.579	60.75	48.41	
50	1.526	12.711	62.18	50.10	
51	1.543	12.847	63.66				
52	1.559	12.984	65.13				
53	1.576	13.126	66.63				
54	1.593	13.270	68.13				

TABLE XXVIII.—DENSITY AND SPECIFIC GRAVITY OF SOLUTIONS HEAVIER THAN WATER.—*Continued*

Degrees Baumé	Specific gravity	Pounds per gallon	Per cent by weight				
			H ₂ SO ₄ * at 60°F.	HNO ₃ * at 60°F.	HCl* at 60°F.	NaOH at 15°C.	Na ₂ CO ₃ at 15°C.
55	1.611	13.417	69.65				
56	1.620	13.568	71.17				
57	1.648	13.722	72.75				
58	1.667	13.880	74.36				
59	1.686	14.041	75.99				
60	1.706	14.207	77.67				
61	1.726	14.376	79.43				
62	1.747	14.549	81.30				
63	1.768	14.726	83.34				
64	1.790	14.908	85.66				
65	1.813	15.094	88.65				
66	1.835	15.285	93.19				

$$\text{Degrees Baumé} = 145 - \frac{145}{\text{specific gravity}}$$

$$\text{Degrees Twaddell} = \frac{\text{specific gravity} - 1.000}{0.005}$$

* Manufacturing Chemists Association.

TABLE XXIX.—SPECIFIC GRAVITY AND DENSITY FOR LIQUIDS LIGHTER THAN WATER

Degrees Baumé	Specific gravity	Pounds per gallon	Percentage NH ₃ * by weight
10.0	1.0000	8.328	0.00
10.5	0.9964	8.298	0.80
11.0	0.9929	8.269	1.62
11.5	0.9894	8.240	2.46
12.0	0.9859	8.211	3.30
12.5	0.9825	8.182	4.16
13.0	0.9790	8.153	5.02
13.5	0.9756	8.125	5.88
14.0	0.9722	8.096	6.74
14.5	0.9689	8.069	7.61
15.0	0.9655	8.041	8.49
15.5	0.9622	8.013	9.38
16.0	0.9589	7.986	10.28
16.5	0.9556	7.958	11.18
17.0	0.9524	7.931	12.10
17.5	0.9491	7.904	13.02
18.0	0.9459	7.877	13.96
18.5	0.9428	7.851	14.90
19.0	0.9396	7.825	15.84
19.5	0.9365	7.799	16.80
20.0	0.9333	7.772	17.76
20.5	0.9302	7.747	18.72
21.0	0.9272	7.721	19.68
21.5	0.9241	7.696	20.64
22.0	0.9211	7.670	21.60
22.5	0.9180	7.645	22.56
23.0	0.9150	7.620	23.52
23.5	0.9121	7.595	24.50
24.0	0.9091	7.570	25.48
24.5	0.9062	7.546	26.46
25.0	0.9032	7.522	27.44
25.5	0.9003	7.498	28.42
26.0	0.8974	7.473	29.40
26.5	0.8945	7.449	30.38
27.0	0.8917	7.425	31.36

TABLE XXIX.—SPECIFIC GRAVITY AND DENSITY FOR LIQUIDS LIGHTER THAN WATER.—*Continued*

Degrees Baumé	Specific gravity	Pounds per gallon	Percentage NH ₃ * by weight
27.5	0.8889	7.402	32.34
28.0	0.8861	7.378	33.32
28.5	0.8833	7.355	34.30
29.0	0.8805	7.332	35.28
29.5	0.8778	7.309	

$$\text{Degrees Baumé} = \frac{140}{\text{specific gravity}} - 130.$$

* Manufacturing Chemists Association.

TABLE XXX.—PROPERTIES OF SODIUM CHLORIDE SOLUTIONS

Temperature, degrees Fahrenheit	Solubility, parts NaCl per 100 parts H ₂ O	Specific gravity of saturated solution	Specific heat of saturated solution
40	35.80	1.2070	0.779
50	35.85	1.2045	0.780
60	35.91	1.2020	0.781
70	36.00	1.1993	0.783
80	36.11	1.1968	0.784
90	36.23	1.1944	0.785
100	36.37	1.1921	0.785
110	36.55	1.1898	0.786
120	36.78	1.1874	0.787
130	37.03	1.1852	0.787
140	37.30	1.1830	0.788
150	37.59	1.1810	
160	37.87	1.1782	
170	38.20	1.1757	
180	38.52	1.1733	
190	38.86	1.1710	
200	39.21	1.1687	
210	39.60	1.1663	
220	40.00	1.1640	
230	40.48	1.1617	

TABLE XXXI.—PROPERTIES OF ELECTROLYTIC CAUSTIC SOLUTIONS*

Percentage NaOH by weight	At 60 degrees Centigrade				At 100 degrees Centigrade			
	Percentage NaCl by weight	Specific gravity 60°/4°	NaCl per 100 NaOH	H ₂ O per 100 NaOH	Percentage NaCl by weight	Specific gravity 100°/4°	NaCl per 100 NaOH	H ₂ O per 100 NaOH
0	27.0	1.187	28.20	1.170
2	25.3	1.195	1,265.00	3,635	26.54	1.177	1,327	3,573
4	23.61	1.202	590.24	1,810	24.88	1.185	622.00	1,778
6	21.94	1.210	365.66	1,201	23.20	1.193	386.66	1,180
8	20.27	1.219	253.37	896.62	21.52	1.201	268.99	881
10	18.70	1.228	187.00	712.91	19.96	1.210	199.59	700
12	17.13	1.237	142.75	590.59	18.40	1.219	154.85	580
14	15.61	1.246	111.49	503.07	16.89	1.229	120.70	493.50
16	14.09	1.256	88.06	437.43	15.38	1.238	96.12	428.87
18	12.60	1.266	70.00	385.77	13.90	1.248	77.22	378.33
20	11.11	1.277	55.54	344.45	12.42	1.259	62.10	337.90
22	9.76	1.287	44.40	310.60	11.08	1.269	50.36	304.18
24	8.42	1.299	35.08	281.58	9.75	1.280	40.62	276.04
26	7.20	1.312	27.39	256.89	8.54	1.292	32.84	251.76
28	5.98	1.325	21.30	234.67	7.33	1.305	26.18	230.93
30	4.97	1.338	16.56	217.26	6.34	1.318	21.13	212.20
32	3.97	1.352	12.40	200.09	5.35	1.332	16.71	195.78
34	3.37	1.367	9.91	184.20	4.76	1.347	14.00	180.11
36	2.77	1.384	7.51	170.08	4.17	1.363	11.59	166.19
38	2.46	1.401	6.47	156.68	3.87	1.380	10.18	152.09
40	2.15	1.419	5.37	144.45	3.57	1.398	8.92	141.25
42	1.98	1.437	4.71	133.38	3.41	1.417	8.12	129.97
44	1.81	1.457	4.11	123.16	3.26	1.435	7.40	119.86
46	1.74	1.476	3.77	113.60	3.20	1.454	6.95	110.43
48	1.67	1.496	3.48	104.85	3.14	1.473	6.55	102.07
50	1.64	1.516	3.28	96.72	3.12	1.493	6.24	93.76
52	1.61	1.536	3.11	89.19	3.07	1.513	5.90	86.38
54	1.59	1.557	2.96	82.44	3.04	1.534	5.62	79.50
56	1.57	1.578	2.81	75.75	2.99	1.555	5.35	73.22
58	1.55	1.601	2.66	69.73	2.95	1.576	5.09	67.31
60	1.53	1.624	2.55	63.11	2.91	1.600	4.85	61.81

* HOOKER, *Trans. Am. Inst. Chem. Eng.*, **13**, I: 74-5 (1920).

INDEX

A

- Absorption of HCl, 116
 - oxides of nitrogen, 85, 102
 - SO₃, 72
- Acid egg, 58
- Acid phosphate, 201
- Agitator, Dorr, 154
- Alberger process, 26
 - flow sheet, 26
 - structure of salt, 31
- Alum, 194
 - manufacture of, 195
 - production, 194
 - uses, 194
- Aluminum sulfate, 194
- American process for ammonia, 98
- Ammonia, cyanamide process, 108
 - density of solutions, 228
 - oxidation, 98
 - catalyst, 101
 - converter, 100
 - equilibrium, 98
 - for H₂SO₄ chamber process, 49
 - preparation of gas, 99
 - pressure process, 103
 - recovery of nitrogen oxides, 101
 - production, 86
 - still, 147
 - synthesis, American process, 98
 - Casale process, 98
 - catalysts, 90
 - Claude process, 97
 - composition of gases in, 94
 - equilibrium, 88
 - Fausser process, 98
 - flow sheet, 86
 - Haber-Bosch process, 97
 - Oppau plant, 76

- Ammonia, synthesis, preparation of
 - N₂ and H₂, from by-product hydrogen, 86
 - from producer and water gas, 91
 - recovery system, 97
 - removal of CO, 93
 - removal of CO₂, 93
 - theory, 88
 - uses, 86
- Ammonia-soda process (*see* Solvay process)
- Ammoniated superphosphate, 203
- Ammonium chloride from Solvay process, 148

B

- Baumé scale, definition, 227, 229
- Baumé tables, 226, 228
- Bauxite, 195
- Bitterns, composition of, 12
- Black ash, 137
- Blast-furnace process for phosphoric acid, 132
- Bleaching powder, 186
 - chamber process, 188
 - mechanical process, 188
- Bones, H₃PO₄ from, 128
- Borax, 208, 213
- Bromine, 215
 - effect of pH on solubility in sea water, 217
 - from Michigan brines, 217
 - from sea water, 215
- Burkeite, 208

C

- Calcium acid phosphate, 201
- Calcium carbide, 106

- Calcium chloride, 214
- Calcium cyanamide, 105
 ammonia from, 108
 as fertilizer, 107
- Calcium hypochlorite, 187
- Calcium sulfate, solubility of, 25
- Caliche, 77
- Carbon dioxide, absorption of, 93, 220
 manufacture, 217
 solubility in $\text{Na}_2\text{CO}_3\text{-NaHCO}_3$ solutions, 218
 solubility in water, 218
- Carbon monoxide, oxidation with H_2O , 93
- Carnallite, 207
- Casale process for ammonia, 98
- Catalyst, for ammonia oxidation, 101
 for ammonia synthesis, 90
 poisoning, 71
 for sulfuric acid, 66, 70
- Catalyst bombs for ammonia synthesis, 95
- Caustic embrittlement, 158, 172
- Caustic pots, 183
- Caustic soda, 150
 boiling points of solutions, 175
 chemical process, Dorr system, 154
 equilibrium, 153
 evaporation, 158
 flakers, 184
 flow sheet, 151
 small plants, 158
 current density in cells, 171
 density, 226
 diaphragm cells, operation of, 170
 electrolytic process, brine supply, 166
 cell efficiency, 165
 cell operation, 170
 cells, 166
 decomposition voltage, 165
 diaphragms, 163
 evaporation, 172
 flow sheet, 159
 sulfate removal, 166, 182
- Caustic soda, electrolytic process, theory, 161
 grades, 151
 mercury cells, 169
 pots, 183
 production, 150
 properties of electrolytic liquors, 230
 purification of, 182
 status of chemical and electrolytic processes, 185
 uses, 150
 voltage in cells, 171
- Cellarius tourills, 122
- Chamber process (*see* Bleaching powder; Sulfuric acid)
- Chemical technology, definition, 1
- Chemico concentrator, 60
- Chile saltpeter (*see* Sodium nitrate)
- Chlorates, formation of, 162
- Chlor-benzene, HCl as by-product, 126
- Chloride of lime (*see* Bleaching powder)
- Chlorine, 150, 185
 compressors, 190
 Deacon process, 186
 drying systems, 190
 electrolytic processes (*see* Caustic soda)
 liquefaction of, 188
 liquid, 186, 188
 compressors, 190
 production, 188
 removal from cells, 170
 shipment of liquid, 191
 synthetic HCl from, 124
 uses, 188
 vapor pressure, 189
 Weldon process, 186
- Claude process for ammonia, 97
- Colemanite, 213
- Compressors for liquefying chlorine, 190
- Concentration of nitric acid, 105
- Concentrator, chemico, 63
 sludge acid, 63
- Condensers for nitric acid, 84

- Contact process (*see* Sulfuric acid) F
 Copper sulfate, 197
 Copperas, 196
 Cottrell system, 50, 62, 133
 Countercurrent decantation, 156
 Crystal alum, 194
 Crystallization, effect of rate, 18, 208
 fractional, 78
 Cyanamide (*see* Calcium cyanamide)
- D
- Deacon process, 186
 Decomposition voltage, 165
 Den, for acid phosphate, 202
 Density tables, 226, 228
 Diaphragms for caustic cells, 163
 Dicalcium phosphate, 201
 Disodium phosphate, 203
 Dorr system, for alum, 195
 for caustic, 154
 Double superphosphate, 202
 Dow cell, 167
 Draw liquor, Solvay process, composition of, 146
 Driers, salt, 31
 Dry ice, 217
 Dust collectors, 50
- E
- Electrolysis of salt brine, theory, 161
 Epsom salts, 199
 Evaporation, of alum, 195
 of chemical caustic, 158
 of copperas, 196
 of electrolytic caustic, 172
 multiple effect, 19
 of salt brines, grainers, 17
 vacuum pans, 19
 Evaporators, factors affecting capacity, 23
 forced circulation, 174
 salt removal from, 22
 "salting" in, 26
 vacuum, 19
- Faraday's law, 164
 Fauser process for ammonia, 98
 Ferrous sulfate, 196
 Fertilizer, acid phosphate, 201
 calcium cyanamide, 107
 potash, 206
 Filters for burner gas, contact process, 70
 Fixed nitrogen, 76
 production, 77
 Flakers, 184
 Flotation, separation of NaCl and KCl by, 213
 Fractional crystallization, 209
- G
- Gas-absorption theory, 116
 Gay-Lussac tower, 57
 Gibbs-Helmholtz equation, 165
 Gibbs-Vorce cell, 167
 Glaserite, 208
 Glauber's salt, 197
 from electrolytic brines, 166, 182
 Glover tower, 50
 capacity of, 53
 construction, 52
 Grainer salt, 15
 Guggenheim process, 78
 Gypsum, solubility of, 25
- H
- Haber-Bosch process for ammonia, 97
 Heavy chemicals, definition, 5
 Hooker type-S cell, 168
 Hopper crystals, 17
 Hydrochloric acid, 111
 absorption of, 116
 by-product, 126
 density, 226
 grades, 111
 heat of solution, 120
 Laury furnace, 116
 Mannheim furnace, 114

- Hydrochloric acid, pot-and-muffle furnace, 113
 production, 111
 from salt, 111
 S-bend absorbers, 136
 salt-cake furnace, 112
 synthetic, 124
 Tantalum absorber, 125
 tourill absorbers, 122
 uses, 111
 vapor pressure of solutions, 117
- Hydrofluoric acid, removal from H_3PO_4 , 128
- Hydrogen, equilibrium with nitrogen, 88
 synthetic HCl from, 124
- Hydrogen chloride, 113
- Hydrogen production, by electrolysis, 162
 from water gas, 91
- Hydrogen sulfide, oxidation to sulfur, 139
- Hypo, 199
- Hypochlorite, formation, 162
- I
- Iodine, 217
- K
- Kieserite, 207
- L
- Laury furnace, 116
- LeBlanc process, 137
- Lime, equilibrium with Na_2CO_3 , 153
- Liquefaction of gases, 188
- Louisiana, production of sulfur in, 39
- M
- Magnesium chloride, 199
 separation from calcium chloride, 200
- Magnesium sulfate, 199
- Mannheim furnace, 114
- Mercury cells, 169
- Mills-Packard system, 59
- Mixed acid, 105
- Modified sodas, 136
- Monocalcium phosphate, 201
- Muriatic acid (*see* Hydrochloric acid)
- N
- New Mexico, potash from, 208
- New York and Liverpool test, 136
- Niter cake, 83, 197
- Niter hog, 49
- Niter supply for chambers, 49
- Nitrate of lime, 77
- Nitric acid, 76
 absorption tower, 85, 102
 ammonia oxidation, pressure process, 103
 (*See also* Ammonia oxidation)
 arc processes, 76, 77
 concentration of, 105
 condensers, 84
 density of solutions, 226
 dissociation, 85
 grades, 80
 production, 80
 recovery from nitrogen oxides, 85, 101
 retorts, 82
 from sodium nitrate, flow sheet, 80
 uses, 79
- Nitrogen, equilibrium with hydrogen, 88
 fixation, ammonia synthesis process, 85
 arc processes, 76, 77
 cyanamide process, 105
 fixed, 76
 oxides, 54
 absorption towers, 102
 oxidation to HNO_3 , 85, 101
 preparation, 91
- Nitrogen Engineering Corporation
 process for ammonia, 98
- Nitrogen tetroxide, 54

- Nitrogen trioxide, 54
 Nitrosyl-sulfuric acid, 51
 Nitrous oxide, 54
- O
- Oleum, 38
 Oppau ammonia plant, 76
 Oxygen, equilibrium with SO_2 , 64
- P
- Phosphate rock, 201
 H_3PO_4 from, 127
 Phosphoric acid, 111, 127
 blast-furnace process, 132
 concentration of, 128
 electric-furnace process, 131
 grades, 127
 H_2SO_4 process, flow sheet, 130
 from phosphorus, 132
 purification, 131
 sulfuric-acid method, 127
 uses, 127
 Phosphorus, 132
 Pickling wastes, 196
 Pipe, dimensions of iron, 225
 Platinum catalyst, for ammonia
 oxidation, 101
 for SO_3 , 70
 Potash, 206
 production, 206
 Potassium chloride (*see* Potash)
 crystallization process, 213
 flotation process, 213
 sodium-chloride system, 209
 Potassium salts, 206
 Precipitates, rates of settling, 156
 Pressure system for ammonia oxidation, 103
 Pumps for sulfuric acid, 58
 Purification of caustic, 182
 Pyrites, 42
 burners, 46
 flash, 48
 hearth, 47
 lump, 46
 in contact process, 69
- R
- Rasorite, 214
 Refrigeration for liquefying chlorine, 190
- S
- Sal soda, 136
 Salt, Alberger process, 26
 boiling points of solutions, 223
 composition of solar bitterns, 12
 crystal structure, 17
 deposits, distribution in United States, 9
 origin of, 8
 driers, 31
 electrolysis of, 159
 grades, 8
 grainer process, 15
 hydrochloric acid from, 111
 manufacturer of, 6
 mining, 10
 pan, structure, 21
 production, 7
 removal from evaporators, 22
 screening, 31
 solar evaporation process, 11
 solubility in caustic solutions, 230
 status of processes, 32
 vacuum evaporation process, 19
 wells, 12
 Salt brines, analyses, 12
 treatment, 13
 Salt cake, 112, 197
 furnaces, 112
 Saltpeter (*see* Sodium nitrate)
 Scale formation, 25
 Screens for salt, 31
 Sea water, composition, 8
 Searles lake, potash from, 207
 Settling of sludges, 156
 Shanks process, 78
 Sicily, production of sulfur in, 39
 Silica absorbers, 124
 Sludge acid, concentration, 62
 vacuum concentration, 63
 Soda ash (*see* Sodium carbonate)

- Sodium bicarbonate, 136
 calcination, 146
- Sodium bromate, 216
- Sodium bromide, 216
- Sodium carbonate, 135
 caustic soda from, 151
 density of solutions, 226
 equilibrium with NaOH, 153
 equilibrium with NaHCO₃ and CO₂, 218
 grades, 136
 LeBlanc process, 137
 production, 135
 Solvay process, 139
 absorption towers, 144
 flow sheet, 140
 uses, 135
- Sodium chloride (*see* Salt)
 mutual solubility of, and potassium chloride, 209
 potassium chloride system, 209
 properties of solutions, 223, 229
- Sodium hydroxide (*see* Caustic soda)
- Sodium nitrate, 77
 mutual solubility of, and sodium chloride, 78
 separation from caliche, 78
 Guggenheim process, 78
 Shanks process, 78
- Sodium phosphates, 203
- Sodium sesquicarbonate, 136
- Sodium sulfate, 197
 solubility, 198
- Sodium thiosulfate, 199
- Solar evaporation, 11
- Solvay process, 139
 operation of, 143
- Specific gravity tables, 226
- Steam, properties, 224
- Sulfates, behavior in caustic cells, 162
- Sulfur, 39
 burners, brick checkerwork, 46
 Glens Falls, 45
 pans, 44
 spray, 46
 Frasch process, 39
 from H₂S, 139
- Sulfur, imports to United States, 41
 production, 41
- Sulfur dioxide, equilibrium with SO₂, 64
- Sulfur trioxide, absorption in H₂SO₄, 72
 equilibrium with SO₂, 64
- Sulfuric acid, 37
 burner gas, composition, 49
 chamber process, chamber construction, 55
 coolers, 58
 dust collectors, 50
 flow sheet, 42
 functions of chambers, 53
 Gay-Lussac tower, 57
 Glover tower, 50
 Mills-Packard system, 59
 movement of gases, 58
 niter supply, 49
 pyrites burners, 46
 special systems, 58
 sulfur burners, 44
 water supply, 55, 56
 concentration, sludge acid, 62
 tower system, 61
 contact process, 64
 absorption system, 72
 Badische process, 75
 catalysts, 70
 filters, 70
 flow sheet, 67
 heat interchangers, 67, 70
 purification system, 69, 70
 rate of reaction, 66
 theory, 64
 density, 226
 distribution, 37
 grades, 38
 monohydrate, 38
 production, 37
 pumps for, 58
 purification of, 59
 pyrites contact plant, 69
 raw materials, 39, 42
 sludge acid, concentration, 62
 sulfur contact plant, 66
 uses of, 38

- Sulfuric acid, vapor pressure of, 61
Superphosphate (*see* Acid phosphate)
 ammoniated, 203
Sylvinite, 207, 208
- Triple superphosphate, 202
Trisodium phosphate, 203
TSP, 203
Tyler S-bend absorbers, 124

T

- Tachydrate, 200
Tantalum absorber, 125
Thickener, Dorr, 154
Tourills, 122
Towers, for absorption of CO₂, 144, 220
 hydrochloric acid, 121
 oxides of nitrogen, 85, 102
 sulfur trioxide, 72
 for drying chlorine, 190
 for Solvay process, 144
Tricalcium phosphate, 201

V

- Vacuum evaporators, for caustic solutions, 174
 forced circulation, 174
Vacuum pan (*see* Evaporator)
Vanadium catalysts, 70
Vorce cell, 167

W

- Water, density and viscosity, 216
Weldon process, 186
Woulff bottles, 122

