

BIRLA CENTRAL LIBRARY

PILANI (RAJASTHAN)

621.384132

Call No

C 14 P

Accession No.

51305

PRACTICAL WIRELESS CIRCUITS

BY

F. J. CAMM

Editor of

"Practical Wireless" and "Practical Television"

WITH 13⁰ ILLUSTRATIONS

LONDON

GEORGE NEWNES LIMITED

TOWER HOUSE, SOUTHAMPTON STREET, STRAND, W.C.2

First published (as Twenty-five Tested Wireless Circuits) 1931
Reprinted (as Practical Wireless Circuits) 1941
Fifteenth Edition 1949
Sixteenth Edition 1954

**MADE AND PRINTED IN GREAT BRITAIN BY
MORRISON AND GIBB LTD., LONDON AND EDINBURGH**

PREFACE

IN this volume are included typical circuits from crystal sets up to multi-valve sets, superhets, and amplifiers, and which my experience as Editor of *Practical Wireless* indicates are in popular demand. It is not possible within a book of this size to include wiring diagrams of all of the receivers, but full-size blue prints for some of the circuits described in this book are available from the publishers at 1s. each. The circuits which are intended for the beginner are accompanied in most cases by wiring diagrams and pictorial sketches.

The circuits incorporate most of the modern refinements, and they have all been built and tested. As here presented they represent the form in which I found that best results were obtained. None of them presents special difficulty in construction and all can be guaranteed to give excellent results. The Room-to-Room Communicator is an interesting addition to the book.

It is hoped that this general collection of circuits—it is believed to be the only work of its kind—will satisfy most requirements.

F. J. CAMM

PREFACE TO SIXTEENTH EDITION

THIS Sixteenth Edition contains a large amount of new matter and includes new circuits on a dual wave crystal diode receiver; an all-dry battery one-valver; an all-dry three-valver; a 3-speed auto-radiogram; and a modern four-valver. The whole of the text has been fully revised although the basic circuits, giving the build-up latitude in the choice of components have been retained.

It is a companion book to *Practical Television Circuits*.

F. J. CAMM.

CONTENTS

	PAGE
CRYSTAL CIRCUITS	5
THEORETICAL SYMBOLS	6
ONE-VALVE SETS	14
TWO-VALVE SETS	24
THREE-VALVE SETS	61
FOUR-VALVE SETS	84
PORTABLE SETS	94
SUPERHET RECEIVERS	106
MAINS SETS	121
UNITS, ADAPTORS, AND AMPLIFIERS	127
ROOM-TO-ROOM COMMUNICATOR	159
DUAL-WAVE CRYSTAL DIODE RECEIVER	164
BATTERY SETS	168
THREE-SPEED AUTOGRAM	186
MINIATURE FOUR VALVE SET	205
TELEVISION RECEIVER	214
CALIBRATING A RECEIVER	216
PRACTICAL WIRELESS BLUEPRINT SERVICE	218

PRACTICAL WIRELESS CIRCUITS

Abbreviations used in Wireless.—To avoid confusion in subsequent references to components which are usually referred to in an abbreviated form, the contractions applied to wireless parts are given on pages 6 and 7.

Conventional Signs used in Wireless Circuits.—

It will help the reader to be able quickly to follow a wireless diagram if he studies the conventional signs shown in Fig. 2. It will be seen from this that various wireless components have conventional signs, and a wireless circuit is a combination of some of those signs. A circuit, it should be remembered, is a theoretical diagram; a wiring diagram shows the actual components with the wires attached. In some of the sets dealt with in this book wiring diagrams are given; in others the circuits only are included. If any difficulty is experienced in reading the circuits, reference should be made to Figs. 2 and 2a.

Circuit No. 1.—Fig. 1 shows the very simplest of circuits, employing a crystal detector and an ordinary plug-in coil tuned with a variable condenser. The coil for the normal broadcast band should be a No. 60 turn (tapped), and for the long waves a No. 250 turn (tapped). A short length of flex should be attached to the aerial terminal and this is connected to the terminal on the X coil which gives the best results.

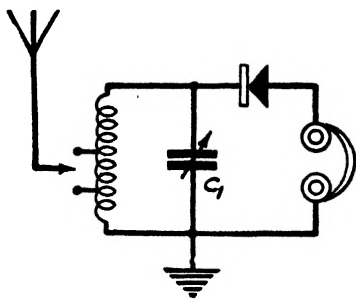

FIG. 1.—The very simplest Crystal Circuit, No. 1.

Any type of crystal may be used, but the permanent type is to be preferred as it keeps its contact longer and generally gives better signal strength.

LIST OF COMPONENTS FOR CIRCUIT NO. 1

- 0005 mfd. variable condenser (C1).
- 1 crystal detector.
- Plug-in coil-holder.
- Plug-in coils.
- Terminals, connecting wire and screws.

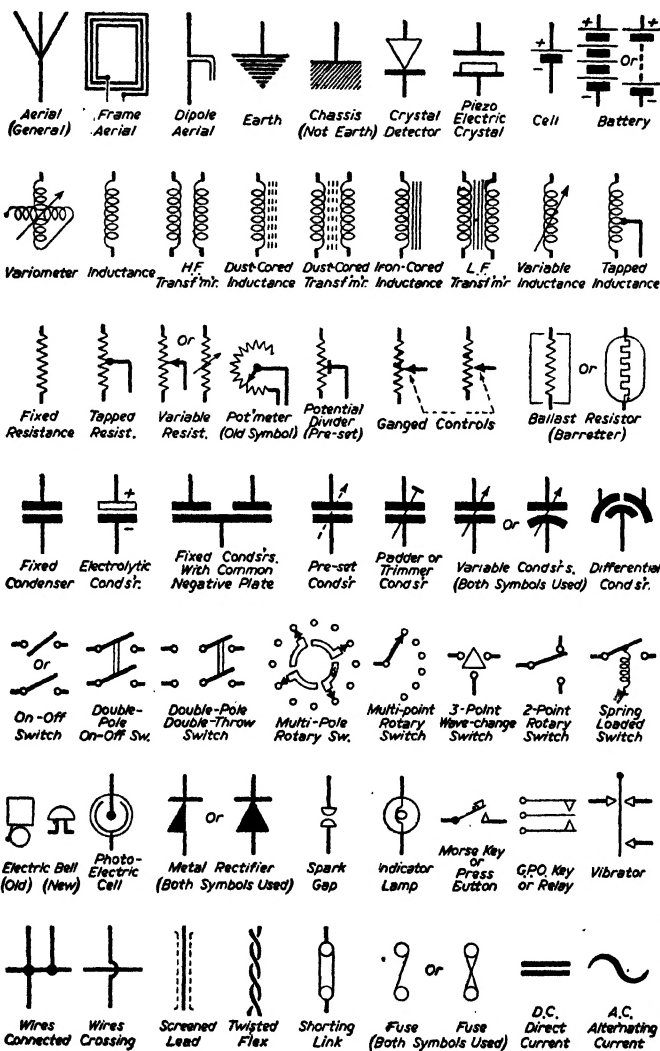

FIG. 2.—Conventional Signs used in Wireless Circuits.

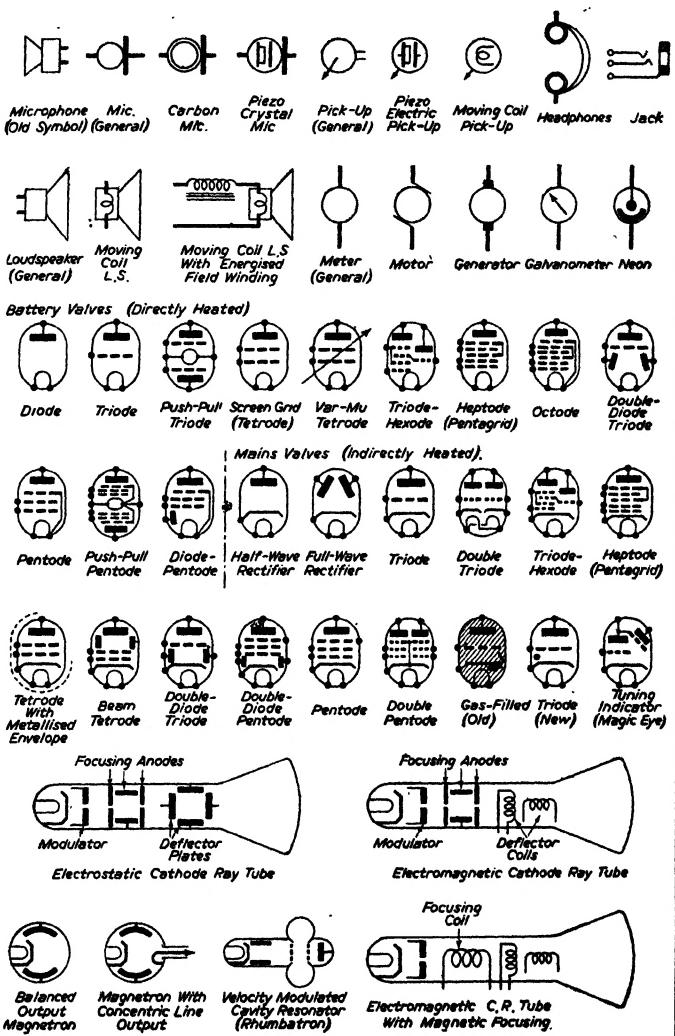

FIG. 2a.—Conventional Signs used in Wireless Circuits.

PRACTICAL WIRELESS CIRCUITS

Circuit No. 2.—A similar arrangement to Circuit No. 1 is shown in Fig. 3, except that a home-made coil is used. A cardboard tube 3 inches in diameter is required, and round this is wound 60 turns of No. 24 D.C.C. wire. At one end a further length of the same wire is passed through the anchoring hole and joined to the first winding. This junction is joined to earth. The short length of wire is then wound over six or seven matchsticks which are stuck across the first winding, and tapping loops are made at the 5th, 10th, 15th, and 20th turns. The aerial is then taken to the tapping which gives best results.

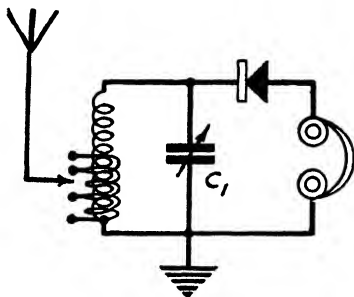

Fig. 3.—Crystal Circuit No. 2 using a home-made tapped coil.

LIST OF COMPONENTS

.0005 mfd. variable condenser (C₁).
1 crystal detector.
Coil, as mentioned in above notes.
Terminals, connecting wire, and screws.

Circuit No. 3.—This receiver has been specially designed so that it can be adapted to suit local conditions. It must be remembered that with a crystal set we cannot use

reaction to compensate for losses or to sharpen up the tuning. It will be noticed in the Circuit Fig. 4 that two of the components are shown in dotted line. The reason for this will be explained later. The set employs a home-made coil, made up of three separate windings. The set is shown in Figs. 5 and 6. The crystal is tapped to a point a short distance from the high-potential end of the coil, and this has the effect of removing the damping exerted in the circuit and gives a slight increase in the sharpness of tuning. The wave-change switch is of the double-pole double-throw type.

In the simplest form all that is necessary to change from medium to long waves is to short-circuit part of the tuning coil, but the same degree of selectivity is not required on the long waves as is needed on the medium waves, and thus it is an advantage to be able to modify the aerial connection when changing wavelengths. It will be seen in this circuit that when in the medium-wave position the

aerial is joined direct to the top or high-potential end of the coil (ignoring the dotted condenser), whereas when switched over to long waves, the aerial is transferred to a point much lower down on the coil. It will be noted that a coil is shown in dotted lines joined between the aerial contact for the long-wave position and the tapping on the coil, and this is a

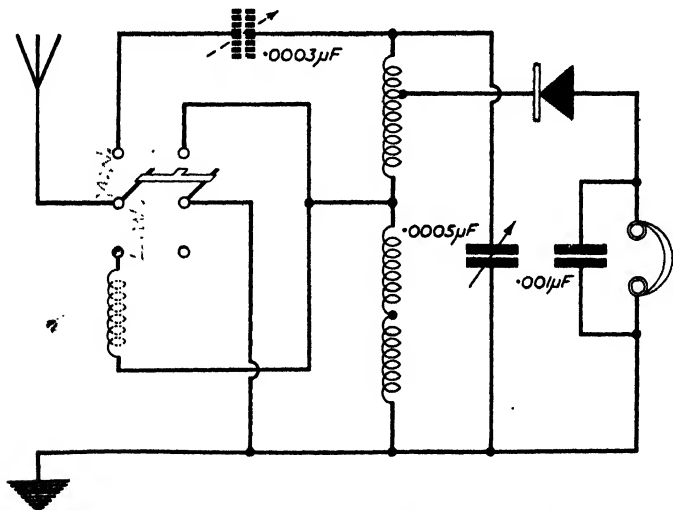

FIG. 4.—Circuit No. 3 for a Modern Crystal Set.

special anti-break-through choke which will be found invaluable to those listeners who are situated close to a medium-wave broadcast station.

The condenser shown in dotted lines is also of value to listeners in a similar position as it may be adjusted to separate the two local stations when a large aerial is employed. Therefore, the receiver should be first made up, ignoring these two components, and if it is found in a particular case that the two locals are heard together, the pre-set condenser should be included between the switch and the top of the coil. Similarly, if when switched over to long waves the medium-wave station can be heard in the background, the special choke should be placed in circuit as shown in the Wiring Diagram.

The panel and baseboard both measure 6 inches by

10 PRACTICAL WIRELESS CIRCUITS

6 inches, and the former is of paxolin. Ordinary $\frac{1}{4}$ -inch three-ply is used for the baseboard. The panel may be drilled by following the measurements and details given in Fig. 7, and the switch and terminal sockets should be attached. The variable condenser is screwed to the baseboard.

The coil (Fig. 8) is wound on a length of paxolin tubing

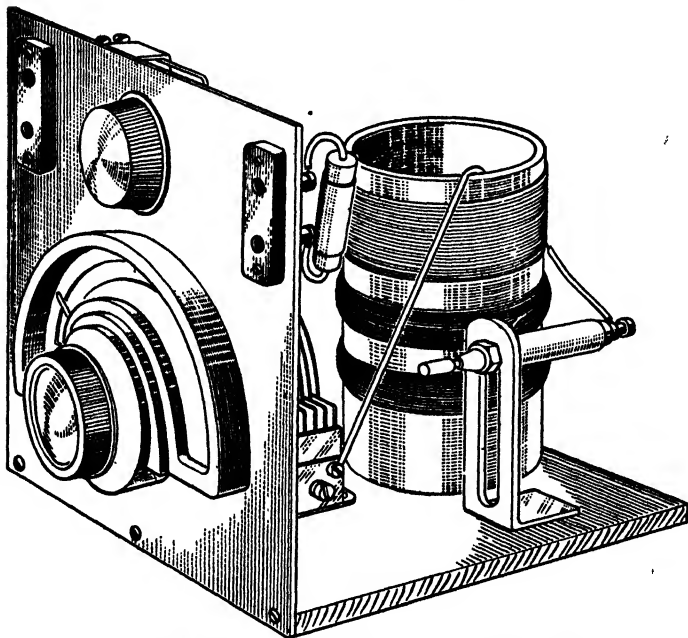

FIG. 5.—Crystal Circuit No. 3 should be built as shown here.

measuring $2\frac{1}{2}$ inches in diameter and 4 inches in length. Two small holes should be pierced at the upper edge and the end of the wire passed through, leaving a length of 5 inches projecting for connection to the variable condenser. Wind on 8 turns and then make a large loop about 2 inches in length, and in the position shown in the diagram of the coil. Continue the winding for another 32 turns and cut the wire so that when passed through a further pair of holes, there will be approximately 5 inches left. About $\frac{1}{4}$ inch from this end of the coil make another pair of holes and pass the

end of the wire through again, leaving a further 5 inches for connection, and then wind on the wire hank fashion for 80 turns, after which let the wire pass across the former for a $\frac{1}{4}$ of an inch or so and wind a similar hank winding of the same number of turns. This will give you a total of 200 turns

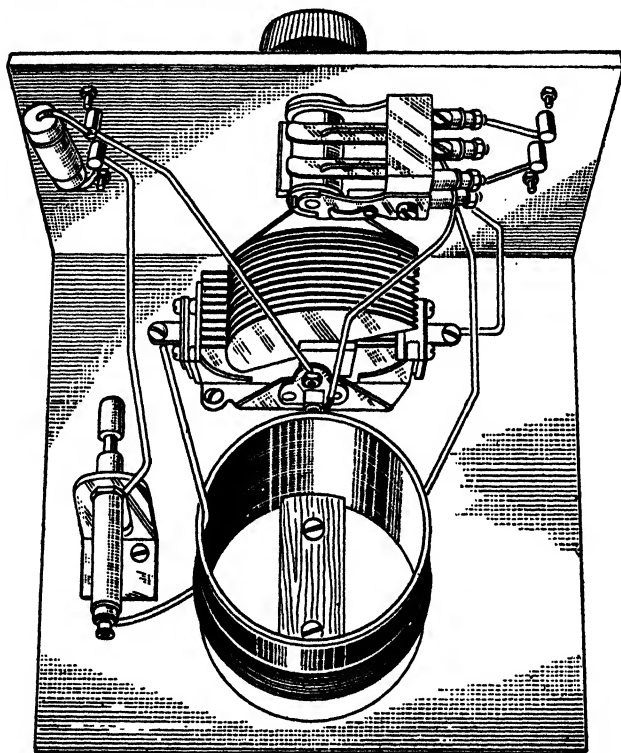

FIG. 6.—A plan view of the Crystal Circuit No. 3.

of wire, the lower two piles forming the long-wave loading coil. The coil is mounted by screwing a strip of wood inside the lower end. Alternatively a disc may be cut from plywood for the purpose.

When the ends of the coils are connected to the respective points (Fig. 9), and if the condenser and choke are to be left out, the end of the first coil and the commencement of

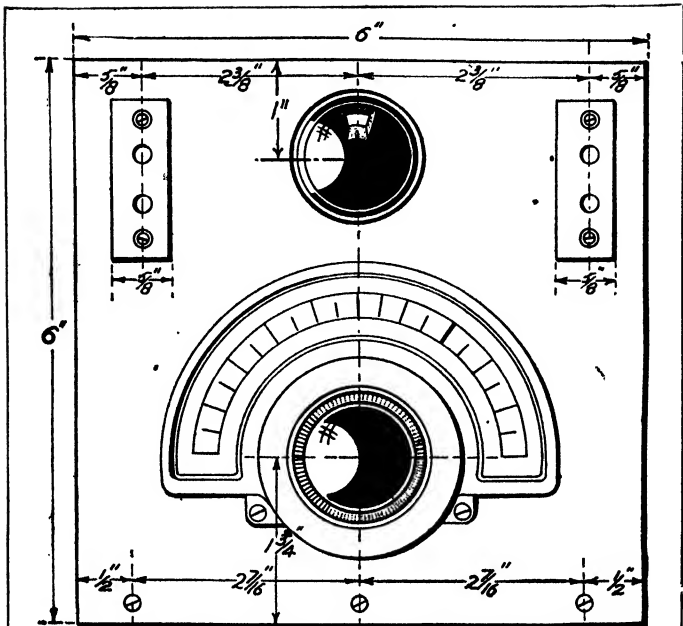

FIG. 7.—Drilling Diagram for the Panel of the Receiver.

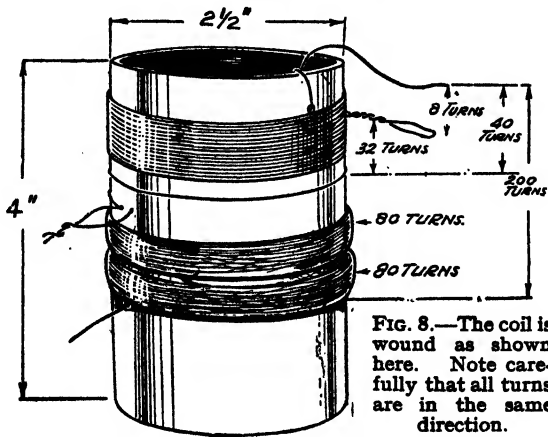

FIG. 8.—The coil is wound as shown here. Note carefully that all turns are in the same direction.

the first of the two-pile windings should be twisted together and taken to the switch. If the choke is to be included it should be joined between the two-switch contacts as shown. Note that the end of the complete coil is joined both to the variable condenser and to the switch and the one length of wire may be used, scraping away the cotton covering for the purpose. The small fixed condenser is joined across the 'phone terminals, and the crystal detector mounted on the component-mounting bracket. The loop of wire in the first part of the coil should be scraped and passed over the end of the detector and locked beneath the terminal nut, whilst the lead from the detector to the 'phone terminals is anchored between the component-mounting bracket and the locking nut on the detector.

The detector should be pulled out, turned and gently released when adjusting the detector. On no account turn this without pulling it out, as by so doing you will spoil the surface of the detector and it will soon need replacing.

If the anti-break-through choke is found necessary it may easily be constructed from the same wire as is used for winding the coil. Cut a disc of plywood about $\frac{1}{4}$ inch

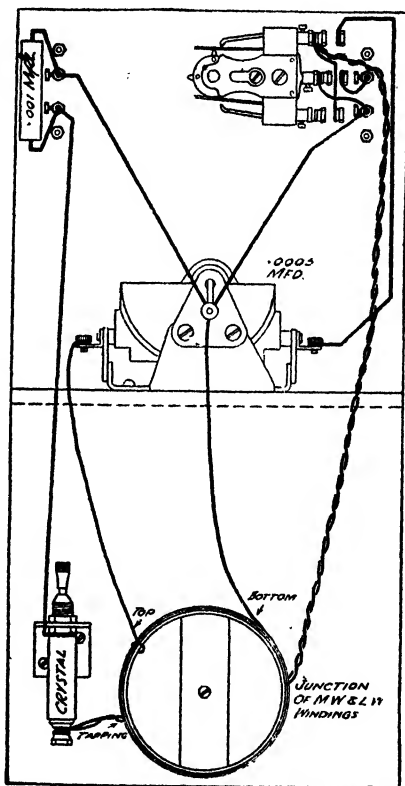

FIG. 9.—Wiring Diagram for Crystal Circuit No. 3.

thick and about 1 inch in diameter, and two discs of similar wood $1\frac{1}{2}$ inches in diameter. Screw these together to form a spool and drill a hole through one disc near the edge of the centre piece. Anchor the wire in this hole and wind 150 turns of wire in the spool, afterwards anchoring the end of the wire through a further hole or by wrapping a piece of ordinary tape round the coil of wire and tying a knot.

(BLUEPRINT NO. P.W.71)

LIST OF COMPONENTS FOR CIRCUIT NO. 3

1 paxolin panel, 6 in. x 6 in.
 1 wooden baseboard, 6 in. x 6 in. x $\frac{1}{4}$ in.
 1 paxolin former $2\frac{1}{2}$ in. x 4 in.
 1 slow-motion condenser with dial.
 1 Red-diamond crystal detector.
 1 component-mounting bracket.

1 double-pole change-over switch.
 2 terminal socket strips.
 1 .001 mfd. tubular condenser.
 Quantity 22 D.C.C. wire, screws, four 4 B.A bolts and nuts.

Circuit No. 4.—The simplest form of single-valve receiver is shown in Fig. 10. The tuning arrangements

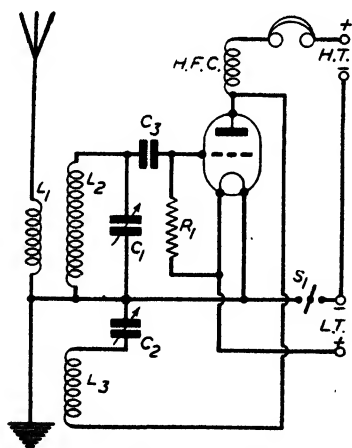

FIG. 10.—A simple One-valve Circuit, No. 4.

consist of three baseboard mounting coil-holders screwed on to a baseboard side by side, with just sufficient space between them to allow the largest size of coil to be comfortably inserted. Care should be taken with the connections to the coil-holders, the earth lead being taken to the pin of the aerial and grid coil-holders, and the anode lead being taken to the pin of the reaction coil-holder. A set of plug-in coils will enable you to listen on any wavelength. For the normal broadcast band the coils should be as follows: L_1 a No. 35 coil, L_2 a No. 60, and L_3 a No. 50 coil. The H.T. should have a value of 60 volts, and the valve should be of the general purpose type.

LIST OF COMPONENTS FOR CIRCUIT NO. 4

- 0005 mfd. variable condenser (C₁).
- 0003 mfd. variable condenser (C₂).
- 0002 mfd. fixed condenser (C₃).
- 1 2-megohm grid leak and holder (R₁).
- 1 valve-holder.
- 3 baseboard mounting coil-holders.
- 1 on-and-off switch (S₁).
- Set of plug-in coils.
- 1 H.F. choke.
- Terminals, connecting wire, and screws.

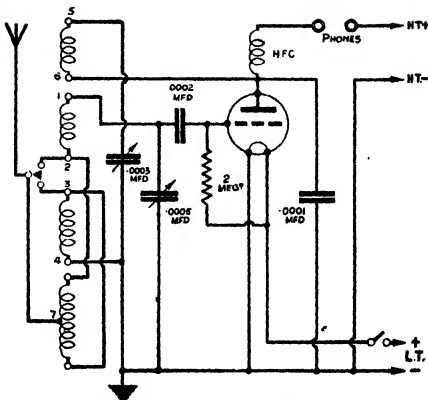

FIG. 11.—Circuit of the single-valve set Circuit No. 5.

Circuit No. 5.—Circuit No. 5 (Fig. 11), employs a home-made coil the dimensions for which are given in Figs. 13 and 14, and method of mounting the coil in Fig. 12. As the panel is screwed direct to the baseboard the latter should be fairly thick, and measure 10 inches by 6 inches, whilst the panel of $\frac{3}{16}$ inch plywood measures 10 inches by 7 inches. For the latter it is better to use a piece of mahogany-faced ply, so that it can be polished when finished.

The sketch (Fig. 15) makes the construction clear.

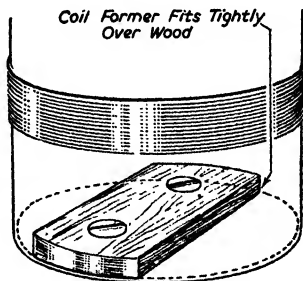

FIG. 12.—A simple and convenient method of mounting the coil for Circuit No. 5 over a piece of wood screwed to the baseboard.

LIST OF COMPONENTS FOR CIRCUIT NO. 5

- 1 tuning coil made as shown in Fig. 11.
- 1 •0005 mfd. panel mounting variable condenser with plain knob and dial.
- 1 •0003 mfd. bakelite dielectric condenser with knob.
- 1 Q.M.B. 2-point on-off switch.
- 1 3-point Q.M.B. on-off switch for wave-changing.
- 1 baseboard mounting 4-pin valveholder.
- 1 •0002 mfd. fixed condenser.
- 1 •0001 mfd. fixed condenser.

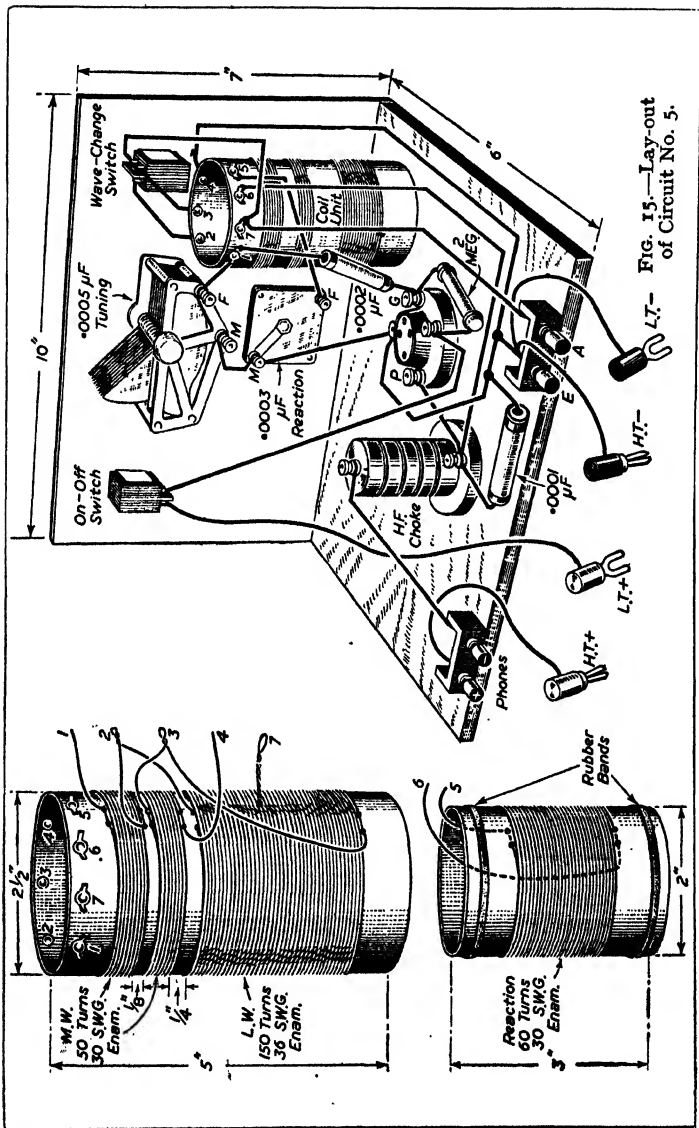

FIG. 15.—Lay-out of Circuit No. 5.

- 1 2-megohm grid leak.
- 1 high-frequency choke.
- 2 terminal mounts marked A and E and 'phones or L.S.
- 2 spade terminals marked L.T. positive and L.T. negative.
- 2 wander plugs marked H.T. positive and H.T. negative.
- Flex, wood screws, and wire.
- 1 pair of high resistance telephones (2000 or 4000 ohms.)
- 1 valve of the detector type.
- 1 2-volt accumulator.
- 1 H.T. battery (100 volt).

Circuit No. 6.—Fig. 16 shows a simple one-valver employing a home-made tuner. The construction of the tuner

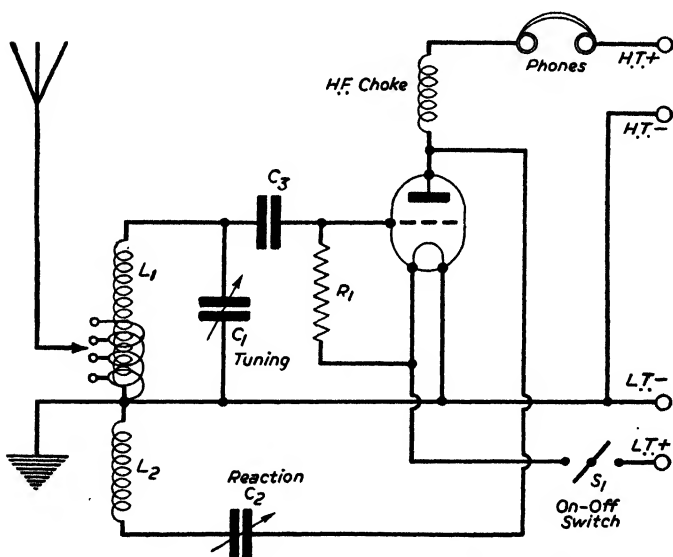

FIG. 16.—Another simple One-valve Set, No. 6.

is similar to that of the crystal set, Circuit No. 2, with an additional winding of No. 30 D.C.C. wire wound on about a quarter of an inch below the earthed end of the primary and secondary coils. The end nearest this junction is also earthed. In other respects the arrangement is similar to Circuit No. 4.

LIST OF COMPONENTS FOR CIRCUIT NO. 6

·0005 mfd. variable condenser (C ₁).	Valve-holder.
·0003 mfd. variable condenser (C ₂).	On-and-off switch (S ₁).
·0002 mfd. fixed condenser (C ₃).	Coil, as mentioned in above notes.
1 H.F. choke.	Terminals, connecting wire, and
1 2-megohm grid leak and holder (R ₁).	screws.

Circuit No. 7.—Although included amongst the one-valvers, the set shown by Fig. 17 consists of two stages, but only employs one valve. It is an H.F. and detector set, employing a crystal detector.

The receiver is intended for use with headphones, but unlike most one-valve sets, it does not consist of a single detector valve. It is actually a two-stage receiver, a valve of the screen-grid type being employed as a high-frequency amplifier, and this is followed by a crystal detector. In this way one is enabled to reach out in a much easier manner than with a reacting detector valve, and those readers who are situated a long way from a broadcasting station, or who desire to hear the numerous foreigners without a large expenditure, will find this a very powerful little set. The construction should not cause any trouble to the veriest novice, and there is very little chance of anything going wrong.

Marking Out.—First of all purchase the various parts and commence by marking out and drilling the ebonite panel. If you do not possess a drill, no doubt your local wireless shop will carry out this part of the work for a few pence. The holes for the variable condensers will, of course, have to be made to accommodate the particular size of fixing bush. This is usually $\frac{3}{8}$ inch. The holes for the vertical aluminium screen must also be spaced to agree with the holes in the screen itself. Next mount the condensers and crystal detector, the four terminals and the screen. This part of the work may now be placed on one side.

Arranging the Parts.—Arrange the remainder of the parts on the wooden baseboard, but before screwing them in place arrange the panel in its position and make sure that there is ample clearance for all parts. When you are quite satisfied with the arrangement, drive in the screws, and fix the ebonite strip containing the battery terminals in its place at the rear of the baseboard. The ebonite panel may

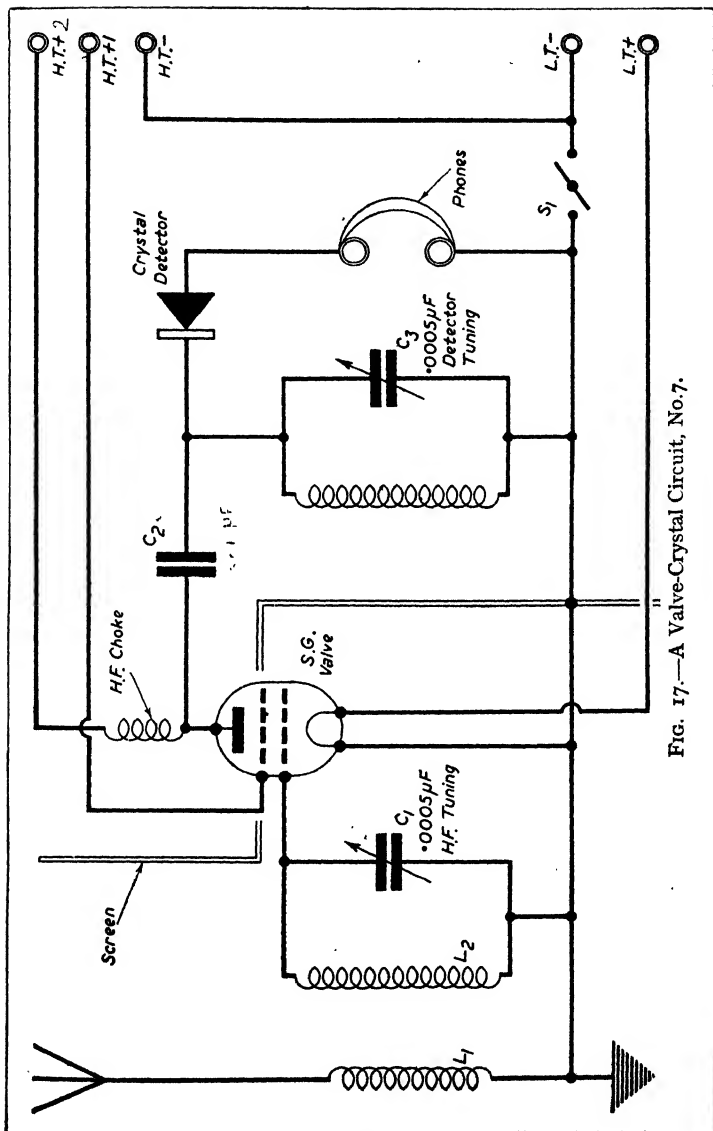

Fig. 17.—A Valve-Crystal Circuit, No.7.

now be fixed and you are ready to wire the receiver (see Fig. 18). This part of the construction of a wireless set is the most important, and if carelessly carried out may result in inefficient working, or even in the destruction of a valve.

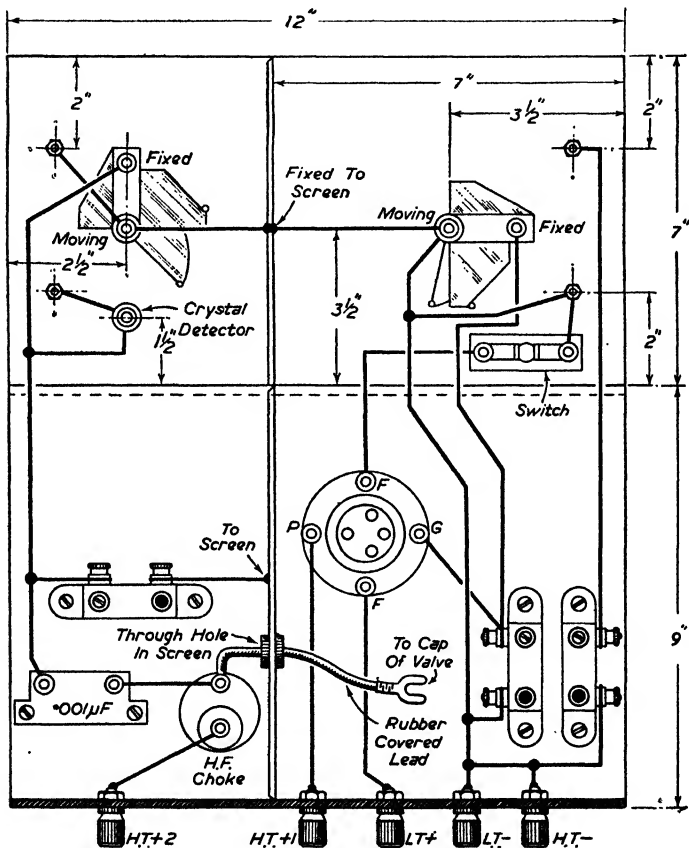

FIG. 18.—Wiring Diagram of the Valve-Crystal Circuit shown by Fig. 17.

No soldering is necessary with the specified components, although there is no reason why those who wish should not use the soldering tags. Keep all wires well spaced, the

closest permissible crossing being $\frac{1}{4}$ inch. As each wire is fixed, cross through the corresponding wire in the wiring diagram to ensure that all wires are put in, and as a check that the correct terminals are connected.

Testing the Set.—In the valve-holder plug a screen-grid valve of the modern 2-volt type, and attach the flexible lead to the terminal on the top of the valve. For the normal broadcast band a No. 25 or 30 coil should be plugged into the left-hand socket and a No. 60 into the socket next to it. In the socket on the right of the vertical screen another No. 60 coil is required. Connect a two-volt accumulator (a 40 ampere-hour type is best) to the L.T. terminals, and the H.T. + 1 terminal should be plugged into a 120-volt battery at the nearest socket to 80 volts. H.T. + 2 goes into the 120-volt socket, and H.T.— into the negative terminal of the battery. Connect the aerial to the upper terminal on the left-hand side of the panel, and the earth to the lower terminal on the same side, whilst a pair of headphones must be connected to the right-hand pair of terminals. Note carefully that the 'phones are connected to the terminals on the right of the panel when viewing from the front.

Tuning In.—Pull out the switch and carefully rotate both dials together. These should tune at roughly the same dial readings, but, especially with weak stations, they must both be in tune, irrespective of the dial numbers, to get maximum signal strength. No difficulty should be experienced in receiving quite a number of stations at good strength, and for those readers who wish to operate a loud-speaker, an ordinary type of amplifier may be connected to the 'phone terminals. Reception on other wave-bands may be carried out by plugging-in the appropriate coils.

LIST OF COMPONENTS FOR CIRCUIT NO. 7

- 1 ebonite panel, 12 in. \times 7 in.
- 1 baseboard, 12 in. \times 9 in.
- 2 variable condensers, '0005 mfd.
- 1 permanent crystal detector.
- 3 baseboard mounting coil-holders.
- 1 fixed condenser, .001.
- 1 H.F. choke—screened-grid type.
- 1 aluminium screen.
- 1 valve-holder.
- 9 terminals.
- Quantity of Glazite connecting wire.

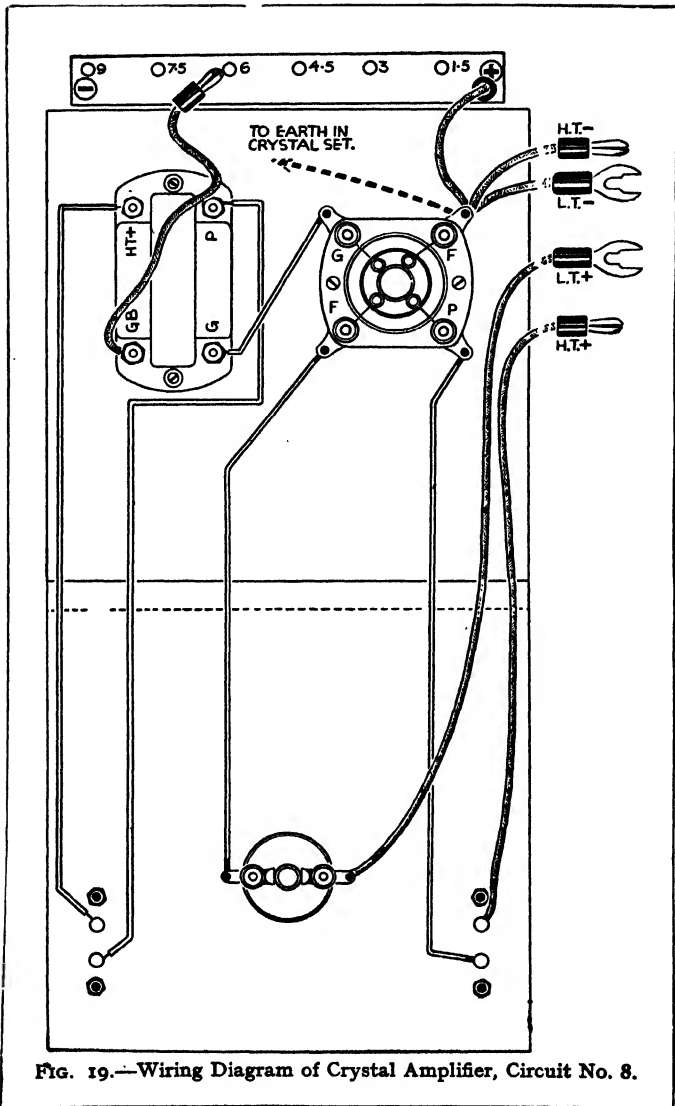

FIG. 19.—Wiring Diagram of Crystal Amplifier, Circuit No. 8.

Circuit No. 8.—Those readers operating crystal sets in districts remote from a broadcasting station and in consequence receiving very weak signals, can add the amplifier shown in Fig. 20 which will increase the strength of the signals considerably. It should be remembered that a crystal set is intended only for local station reception, although instances are on record of the reception of American

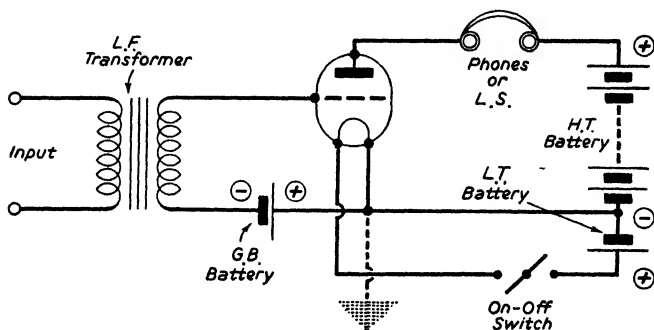

FIG. 20.—Circuit No. 8 for Crystal Amplifier, with the various components clearly identified.

and continental programmes on it when conditions are suitable. It will be seen that a low-frequency transformer is used to feed the signals to a valve, instead of taking them direct to the headphones. The transformer should have a ratio of about 5 to 1. The wiring diagram Fig. 19 is self explanatory. When the wiring is completed the unit should be placed alongside the crystal set, and the two phone sockets on this should be connected across to the two input sockets on the amplifier, Fig. 21, whilst the phones should be plugged into the other socket strip on to the amplifier panel.

In some cases even greater amplification may be desirable, and in that case you can use a pentode valve instead of the L.F. type just mentioned. In this case, you will use a 5-pin valveholder instead of a 4-pin one, and the extra point will be fitted with another battery lead. To the end of this a red plug marked H.T.1 should preferably be fitted, or alternatively a lead of a totally different colour may be used (this will be the case if a 5-way battery cord is purchased). This lead should be inserted into a socket just below the maximum used for the other positive lead, but

later it may be joined direct to the maximum lead with a decoupling scheme. However, this will be dealt with in its place. Again, the G.B. will have to be adjusted according to the makers' instructions for the particular value in use.

LIST OF COMPONENTS FOR CIRCUIT NO. 8

- 1 wooden baseboard 6 in. x 6 in.
- 1 paxolin panel 6 in. x 6 in.
- 1 L.F. transformer (ratio 5 to 1).
- 1 valveholder (4-pin or 5-pin according to valve used—see text).
- 1 multiple battery cord, or supply of flex and plugs.
- 1 L.F. valve.
- 1 push-pull on-off switch.
- 2 terminal socket strips.
- 1 coil of connecting wire.
- 1 2-volt L.T. accumulator.
- 1 H.T. battery (see text)
- 1 9-volt G.B. battery.

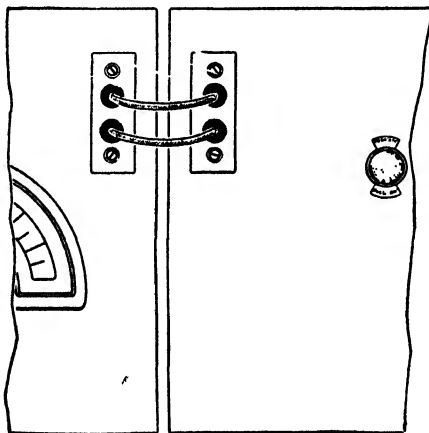

FIG. 21.—How the Crystal Set and the Amplifier (Circuit No. 8) are connected together.

Circuit No. 9.—This is a two-valve set (Fig. 22), designed for purity of reproduction. Plug-in coils are used, and the remarks on Circuit No. 4 relative to this part of the circuit will also apply. The resistance R_2 , the condenser C_4 , and the resistance R_3 are all incorporated in the commercial type of resistance coupling unit, and this may be used instead of the separate components if desired. The second valve should be of the L.F. type, and the H.T. should have a value of 120 volts, with the grid bias adjusted according to the particular instructions of the valve maker.

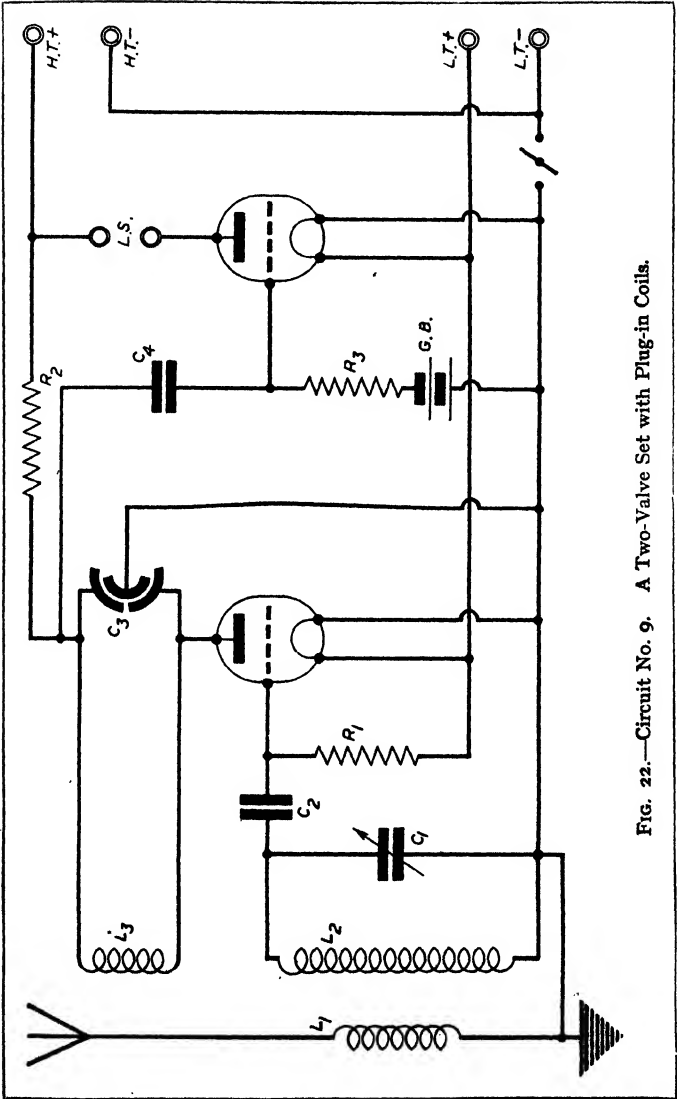

FIG. 22.—Circuit No. 9. A Two-Valve Set with Plug-in Coils.

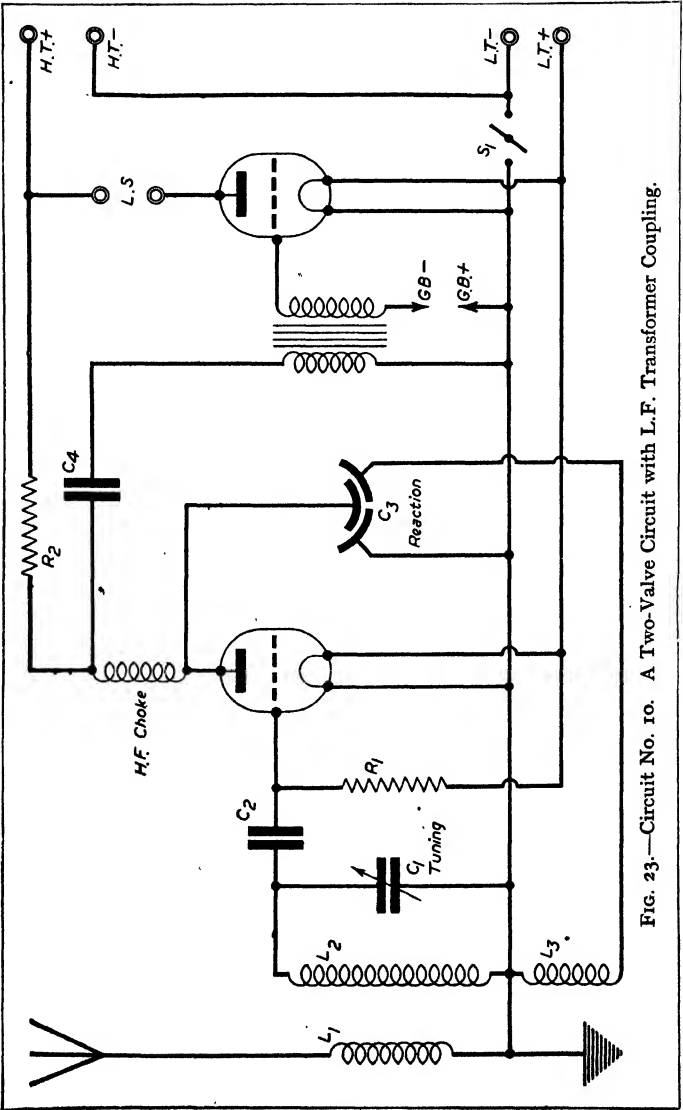

FIG. 23.—Circuit No. 10. A Two-Valve Circuit with L.F. Transformer Coupling.

LIST OF COMPONENTS

·0005 mfd. variable condenser (C₁).
 ·0002 mfd. differential reaction condenser (C₃).
 ·0002 mfd. fixed condenser (C₂).
 ·01 mfd. fixed condenser (C₄).
 1 2-megohm grid leak and clips (R₁).
 1 100,000-ohm resistance and holder (R₂).
 1 25,000-ohm resistance and holder (R₃).
 2 valve-holders.
 1 on-and-off switch (S₁).
 3 coil-holders.
 Set of coils.
 Terminals, connecting wire, and screws.

Circuit No. 10.—Fig. 23 is a similar set to the preceding one, but this time an ordinary L.F. transformer is employed. In order to keep the quality of reproduction on a high standard, this transformer is parallel fed, that is, the primary is not placed direct in the anode circuit of the detector valve, and therefore no current passes through its primary. This keeps its inductance high and preserves the bass notes. Further, the values of the grid condenser and leak have been modified to give what is known as power grid detection. Consequently, provided plenty of H.T. is employed, this receiver will give absolutely tiptop quality.

LIST OF COMPONENTS FOR CIRCUIT NO. 10

·0005 mfd. variable condenser (C₁).
 ·0001 mfd. fixed condenser (C₂).
 ·0002 mfd. differential condenser (C₃).
 1 1-mfd. fixed condenser (C₄).
 1 250,000-ohm resistance and holder (R₁).
 1 30,000-ohm resistance and holder (R₂).
 1 L.F. transformer.
 3 coil-holders.
 Set of coils.
 2 valve-holders.
 On-and-off switch (S₁).
 Terminals, connecting wire, and screws.

Circuit No. 11.—The two-valver shown by Fig. 24 is designed primarily for long-distance headphone work, and consists of a screen-grid H.F. stage followed by a simple detector valve. The aerial circuit consists of a 60 turn (tapped) coil, and the coils L₂, L₃, and L₄ are included in a

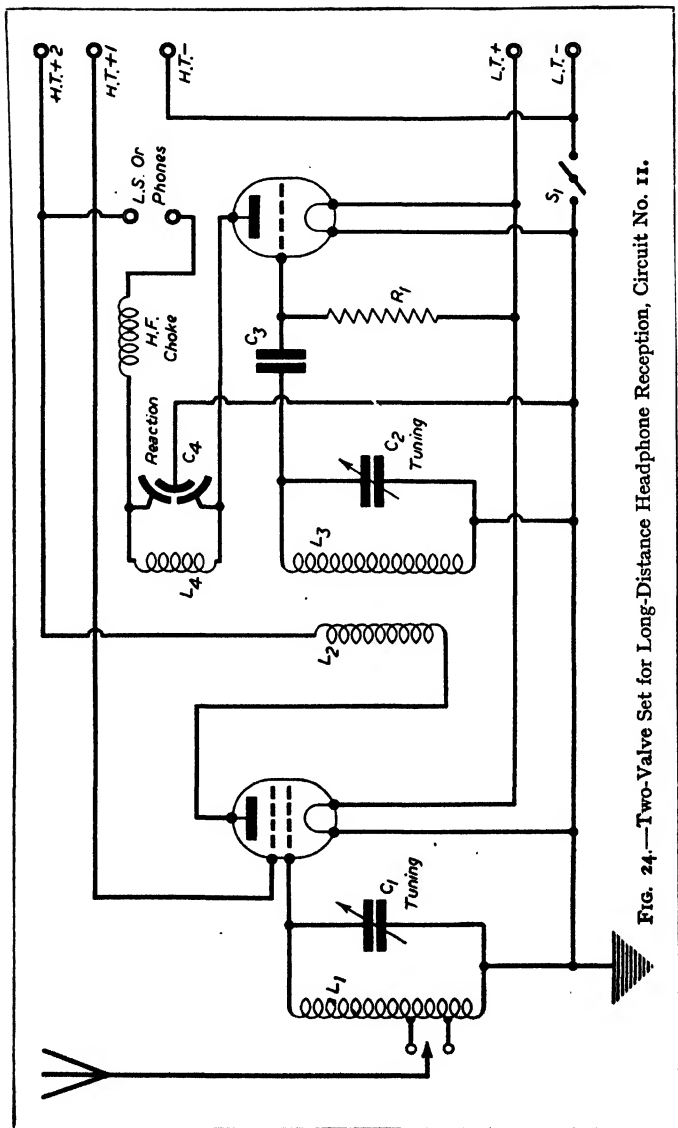
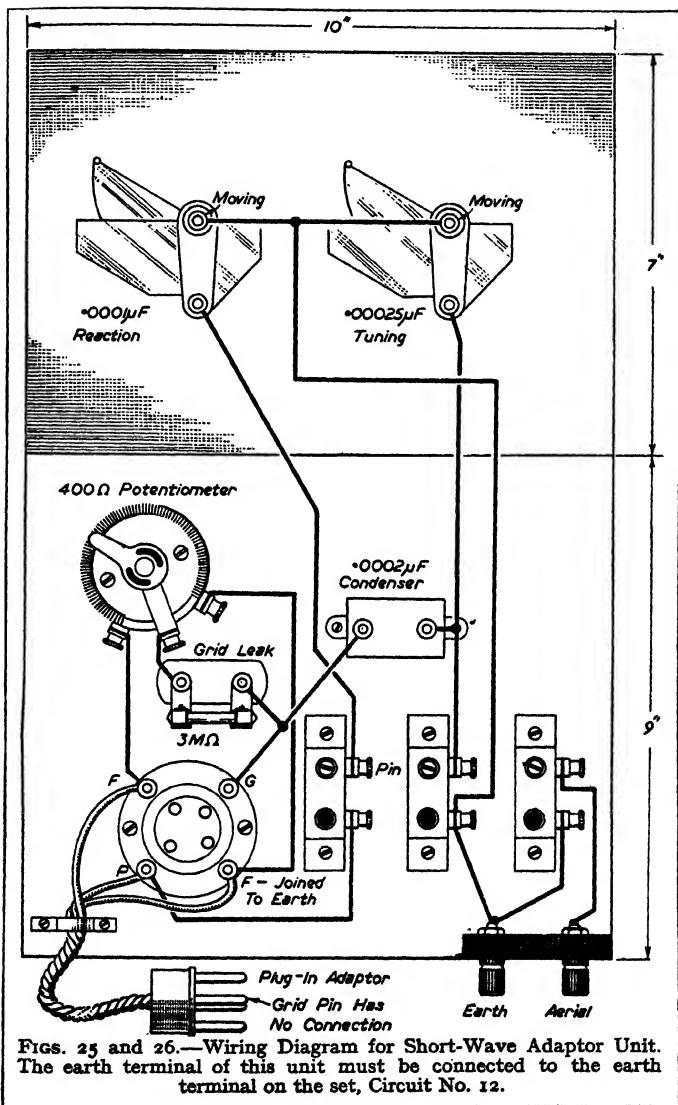

FIG. 24.—Two-Valve Set for Long-Distance Headphone Reception, Circuit No. 11.



Figs. 25 and 26.—Wiring Diagram for Short-Wave Adaptor Unit. The earth terminal of this unit must be connected to the earth terminal on the set, Circuit No. 12.

commercial six-pin coil unit. Several firms make this H.F. transformer as it is called, and therefore any particular make may be chosen by the constructor. Care should be taken that a transformer for use with S.G. valves is obtained as there is a different type of transformer for the triodes, or ordinary three-electrode valve. Differential reaction control is employed for stability, and the detector valve may be of the H.F. or general purpose type. As there are two tuned circuits in this receiver, care will have to be exercised in tuning in, as, unless both circuits are tuned to the wavelength of the desired station, nothing will be heard, unless, of course, the station is very close to you.

LIST OF COMPONENTS FOR CIRCUIT NO. 11

- 2 .0005 variable condensers (C_1 and C_2).
- 1 .0002 fixed condensers (C_3).
- 1 2-megohm grid leak and holder (R_1).
- 1 differential reaction condenser (C_4).
- 1 H.F. choke.
- 1 6-pin H.F. transformer and base.
- 1 Plug-in 2-pin coil-holder.
- 1 tapped 60 turn coil.
- 2 valve-holders.
- 1 on-and-off switch (S_1).
- Terminals, connecting wire, and screws.

Circuit No. 12.—This short-wave adaptor unit (Figs. 25-26) has been designed for attachment to existing sets. Those possessing ordinary receivers, which have been built for the broadcast band, often wish they were able to tune down to the short waves and pick up stations situated as far away as America or on the other side of the globe, Kenya, etc. These short waves seem to come in remarkably well, and the short-wave unit here described may be connected to any ordinary receiver (provided it is not a Mains driven set), and which will enable reception to be carried out on most of the short wavelengths at present in use. The unit is quite cheap and is very simple to construct. No extra valve is needed, as will be explained later.

The list of components should be studied, and practically any make of standard design may be used. The only point which requires careful attention is the method of connection used in the variable condensers. These must be fitted with "pigtail" connections if rustling noises are to be avoided when tuning in on the short waves. Most of the better

makes of variable condenser now employ this method of connection.

The Panel Lay-out.—Having obtained the various parts, proceed to mark out the panel, using as your guide the measurements given on the wiring diagram. The exact size of the holes will depend, of course, on the particular make of component chosen. Mount up the condensers and then proceed to fix the remaining components to the base-board. Pay particular attention to the coil-holders, allowing sufficient space between them to permit the largest of the coils to be safely inserted without touching its neighbour. The only two terminals required in this unit may be mounted on a spare piece of ebonite, or one of the Belling-Lee special terminal blocks may be purchased; they are cheap.

When everything is in its place you may proceed to wire up. This should be carried out with heavy gauge wire, say 16 or 18 bare copper, well spaced, and by the most direct method. Do not try to make this part of the work look neat by taking the leads a long way round with nice right-angle bends. Where short waves are concerned the leads must be as short and direct as possible. Do not let any wire run within $\frac{1}{2}$ inch of another unless it crosses at a dead right angle. Attention to this part of the work will be well repaid in efficient working. Note also that the moving vanes of both condensers are connected together and to earth.

The Connecting Link.—When the unit is wired you will have to make the actual connecting link with your present receiver, and this will have to be made of such a length that it will comfortably reach your present detector socket. Three single lengths of flex are required, and to avoid mistakes these should preferably be of different colours. Alternatively, you may cut three lengths of ordinary flex and bind the ends of each separate strand with a different coloured thread. These three strands are connected up in the following way. One strand to each of the filament terminals of the valve-holder in the unit, and to each filament pin of the valve adaptor. The remaining strand from the plate terminal of the valve-holder to the plate pin of the adaptor. No connection whatever is made to the grid pin of this adaptor.

Having finished this part of the work, carefully check over all connections, and when you are quite sure no mistakes have

been made you may proceed to connect it to your present receiver. This is quite a simple job. Take out the detector valve of the set, and plug it into the valve-holder of the short-wave unit. The valve adapter is then plugged into the now empty valve-holder of your existing set. The aerial and earth leads should then be disconnected from your receiver, and taken to the two terminals on the unit. If now the receiver is switched on, the short-wave unit becomes a very efficient one-valve short-wave set, and the low-frequency stages of your present receiver serve to amplify the received signals. If there are two such stages, quite good loud-speaker signals will be obtained.

Ensuring Maximum Results.—The following refinements may be mentioned to ensure maximum results in short-wave work. If oscillation seems rather erratic, carefully adjust the position of the arm of the potentiometer. If this does not seem to help matters, look at the H.F. choke in your existing receiver. This may not be good enough for short-wave work, and you should therefore obtain one which is efficient on all waves. Tuning on the short waves is very critical, and you will have to adjust the tuning dial with much more care than you are accustomed to employ on the ordinary broadcast band. If you buy a complete set of short-wave coils, try the effect of different sizes of coil in the left-hand, or aperiodic aerial, coil-holder. Generally speaking, this coil should be two sizes smaller than that used in the centre holder, and the right-hand, or reaction coil, should be of a size between these two.

For those who wish to make their own short-wave coils, it is best to make up a set having 2, 4, 6, 8, 10, 12, 14, and 16 turns of No. 16 gauge tinned copper wire, wound round a 3-inch diameter former and then allowed to spring off. The four smaller sizes should be allowed to space themselves out with about $\frac{1}{4}$ inch between the turns, and the four larger ones should have a space between turns equal to the thickness of the wire. The ends of the coils may be made fast to ordinary plug-in coil-holders, and provided care is taken in handling them, they will be found to keep themselves quite rigid.

LIST OF COMPONENTS FOR CIRCUIT NO. 12

Panel, 10 in. \times 7 in.

Baseboard, 10 in. \times 8 in. or 9 in.

1 .00025-mfd. variable condenser, with slow-motion dial.

1 .0001-mfd. variable condenser, with slow-motion dial.

- 3 baseboard mounting coil-holders.
- 1 .0002 fixed condenser.
- 1 3-megohm grid leak and holder.
- 1 400-ohm potentiometer for baseboard mounting.
- 1 anti-microphonic valve-holder.
- 1 set of short-wave coils.
- 1 plug-in valve adapter.
- Flex, wire, screws, etc.
- 2 terminals.

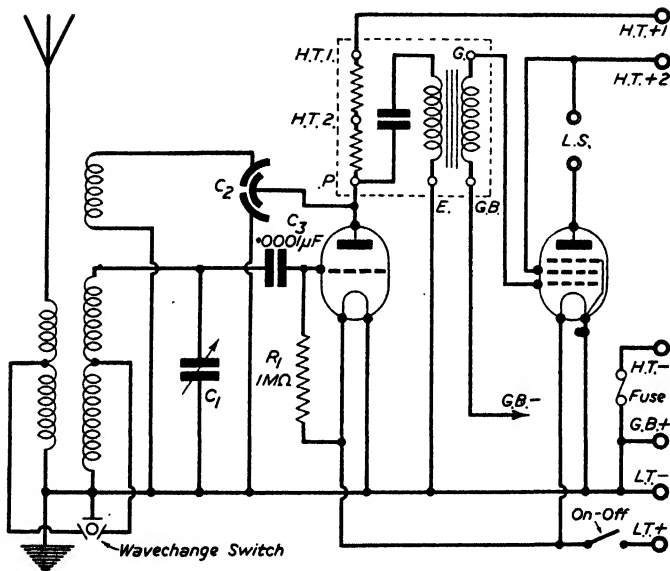

FIG. 27.—Circuit No. 13.

Circuit No. 13.—Fig. 27 shows a very popular form of detector—L.F. arrangement, a triode valve being used in the detector stage and an economy pentode in the output stage. The coil is of the dual-range type, wave-changing being effected by means of an external 3-point switch. The circuit is of the transformer type, so that a high degree of selectivity can be obtained if the reaction condenser is judiciously operated. The coil employed works best with an outside aerial of moderate length—about 40 feet. If a longer aerial is used it will be advisable to connect a fixed

condenser of about .0002 mfd. between the aerial lead and the aerial socket of the set. Fig. 28 shows the cabinet drilling dimensions, Fig. 29 the completed chassis, and Fig. 30 the wiring diagram.

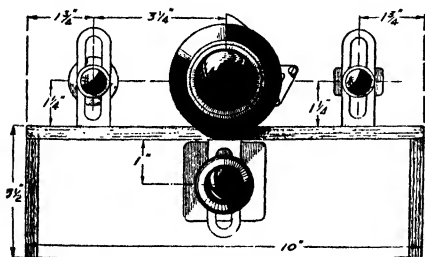

FIG. 28.—Method of mounting the controls for Circuit No. 13.

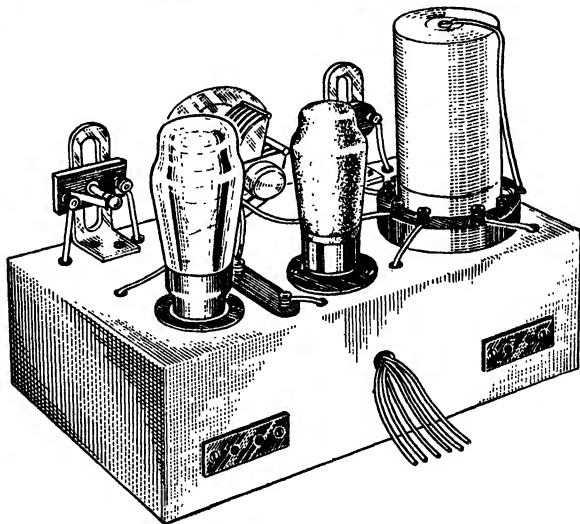

FIG. 29.—Circuit No. 13 as built.

(BLUEPRINT NO. P.W.76)

Reaction is provided by means of a differential reaction condenser, thereby ensuring an effective path to earth for the H.F. component at the anode of the detector valve. A special L.F. coupling unit is used between the detector

and output valves. This incorporates a resistance as well as a transformer. Parallel-feed coupling is therefore provided with resultant good bass

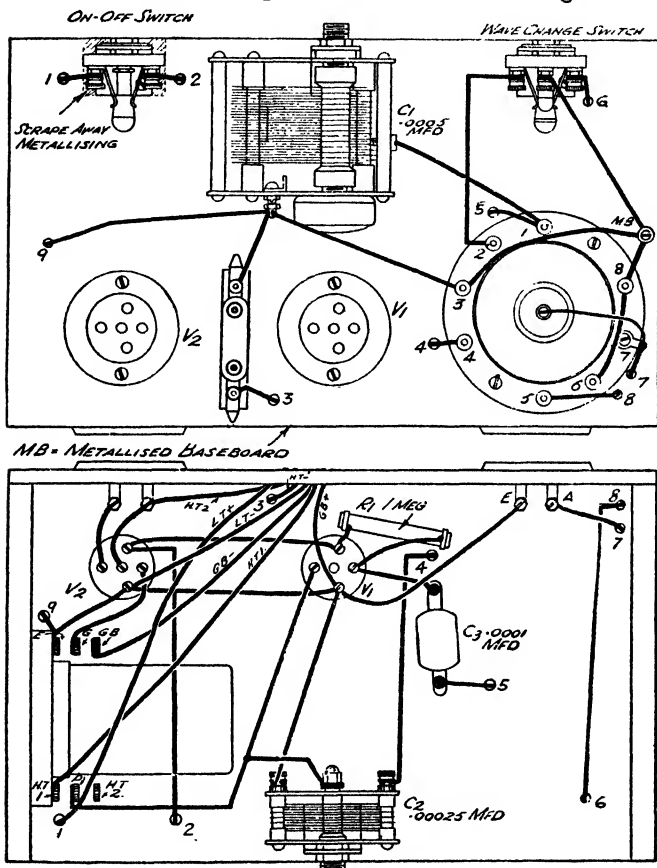

FIG. 30.—Wiring Diagram of Circuit No. 13.

response. When a straight transformer coupler is used direct current passes through the primary winding of the transformer and bass response is consequently adversely affected. The transformer section of the coupling unit has a step-up

ratio of 3/1, and therefore an adequate input for the pentode valve is assured.

This simple little set can be relied upon to pick up medium-wave stations at a distance of approximately 100 miles when a reasonably efficient aerial is employed, and reception of Droitwich on the long wave-band may be obtained in most parts of the country. This does not mean that foreign station reception is impossible; with an efficient aerial several continental stations will be picked up after dark.

LIST OF COMPONENTS FOR CIRCUIT NO. 13

- 1 dual-range coil.
- 1 ·0005 mfd. condenser (C.1).
- 1 ·0002 mfd. reaction condenser (C.2).
- 1 L.F. coupler.
- 1 resistance, 1 megohm (R.1).
- 1 ·0001 mfd. condenser (C.3).
- 1 2-point switch, 1 3-point switch.
- 2 terminal strips marked A.E. and L.S.
- 2 valveholders—1 4-pin and 1 5-pin.
- 2 valves—1 detector and 1 pentode.
- 5 plugs marked H.T. negative, H.T.1, H.T.2, G.B. + and G.B. -
- 2 spade terminals marked L.T. - and L.T. +
- 4 component brackets.
- Metallised chassis 10 in. × 6 in. × 3 in.
- 1 100-m/a. fuse and holder.
- 1 loud-speaker.

Circuit No. 14.—Circuit No. 14 is a Short-Wave Two-Valver. This is a set (see Fig. 31) designed for those

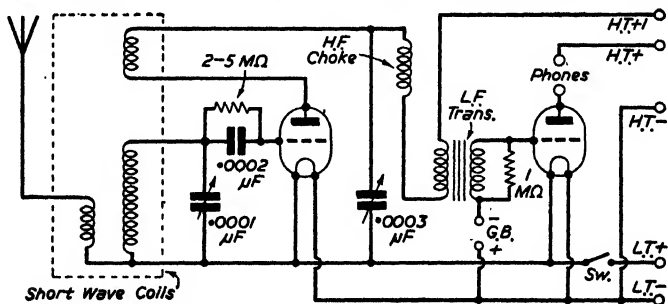

FIG. 31.—Circuit No. 14 for a Short-Wave Two-Valve Set.

who are tired of receiving the local stations only, and yet do not feel like tackling a complicated multi-valver for

receiving the more distant stuff. The short-wave receiver is an ideal set for everyone—as you receive programmes from seemingly impossible distances, with the minimum of trouble and the minimum of expense.

Contrary to general opinion, a short-wave set need not be hard to construct, hard to handle, or complicated in the slightest degree. Experts have proved time after time that, as far as short waves are concerned, the simplest set is the best. Accordingly, the set described here is devoid of gadgets, or ornamentation of any kind, and yet is as efficient as possible.

It should be noted that the front panel houses the two tuning controls, both fitted with slow-motion dials, and the on-off switch. The left-hand dial controls the main tuning, and the right-hand the reaction control. The only component in the set that differs seriously from a similar two-valve broadcast receiver is the set of short-wave coils. Several excellent makes are on the market, although directions for making them are given at a later stage.

Setting out the Baseboard.—The set is housed on a baseboard 14 inches \times 7 inches, on which is mounted a vertical panel of the same dimensions. Although bakelite has been used for the latter, all three components mounted on it are at earth potential, and consequently insulating properties are of no importance. Metal or wood can be used according to your own particular preference.

Very carefully examine the circuit diagram before fixing the parts to the baseboard; and also the wiring diagram (Fig. 33), and do *not* deviate from these more than you can help. The efficient working of a short-wave receiver depends very largely upon the efficiency of the lay-out. This is far more the case than one finds with any broadcast receiver, for a very small “stray capacity” introduced by two wires running close together, or by two components in certain positions, means a lot more on wavelengths of the order of 20 metres or so. It will be seen that not much space has been wasted; at the same time the spacing is adequate, and there should be no need to make the baseboard larger with a view to “improving” the set. Such a proceeding would almost certainly have the opposite effect by introducing wires of unnecessary length.

The Tuning Condenser.—This has a capacity of .0001 mf. only. This is, of course, small, judging by the usual standards, but even so it is large enough to cover a far wider band of

frequencies than we ever cover on the normal 300-500 metre waves. It is, of course, a fact that there is more "station-room" in the five metres between 30 and 35, for instance, than there is between 200 and 600! Thus, if we try to cover too wide a band with one swing of the tuning condenser, no one but a superman can hold a station, even if he succeeds in finding it at all. With this .0003 condenser three plug-in coils are needed to cover all the interesting wavelengths. The three bands into which the range is split up are roughly 15 to 30 metres, 30 to 60 metres, and 60 to 130 metres. All the long-distance broadcast that can be received at all regularly on the short waves is somewhere in these three bands. This allows comfortable tuning without incessant coil-changing.

The other variable condenser, for control of reaction, is of

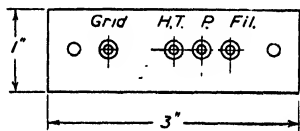
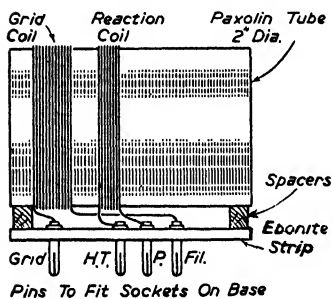

FIG 32.—The Construction of the Coils of the Short-Wave Two-Valve Circuit No. 14, and the Lay-out of the Base for the Short-Wave Coils.

.0003 mf. capacity, the usual value for this purpose. The method used for this control, incidentally, is probably the best of all the known methods for short-wave work, and when the set is properly adjusted, gives a beautifully fine and smooth control. Swinging-coil reaction is, of course, years out of date, although it can still be seen in use.

Lay out the components and the wire up in accordance with the diagrams given, check over carefully, and insert the valves as follows: for the detector (the right-hand valve-holder from the back), use an "H.F." type—the standard general-purpose and detector valve. The make is unimportant, and the voltage must, of course, be chosen to suit the accumulator with which you propose to use the set. For the L.F. stage use a good power valve of the same rating.

Connect the H.T.— terminal to the negative end of your battery. H.T.+1 to a tapping in the region of 60 volts, and H.T.+2 to the full voltage, which should be 100 or 120. There is little point in using more, for even a simple two-valver of this kind is capable of producing very loud signals.

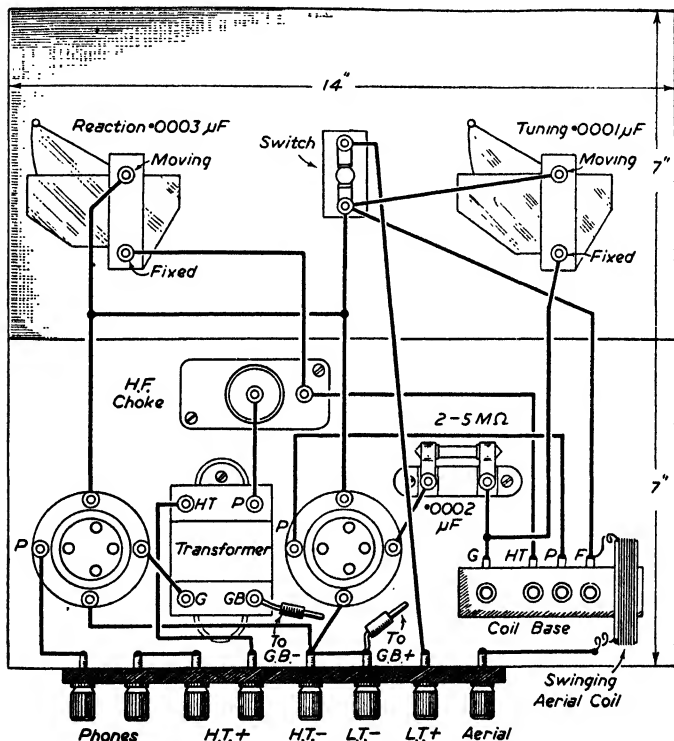

FIG. 33.—Wiring Diagram for the Short-Wave Two-Valve Set.

The Telephones and Accumulator.—These have now to be connected to their respective pairs of terminals, and also the aerial, which has not yet been mentioned. All the terminals, of course, are housed on one ebonite strip at the rear.

There is no particular point in using a very large aerial, since a small indoor type, run round the picture-rail, or taken straight across the ceiling, will often give equally good signals. Your particular location will almost certainly enter into the question, and it will pay you to experiment with different lengths and heights. No provision has been made for the use of an earth on the set, since it very rarely has any effect at all on these waves.

Having connected everything up in readiness for listening, the set is ready for its first tests. Switch on, set the tuning control to any position that occurs to you, and gently revolve the reaction control from the zero position upwards. You should be able to hear the set go into oscillation, with the faintest hiss. There should be no plop or musical howl at this point.

This state having been achieved, search for signals on the tuning control, handling it very gently, particularly if you are a newcomer to the short-wave bands. You will hear numbers of Morse signals from the many high-power commercial stations, which will indicate whether the set is in order or not. Among these, if you are listening during the evening, you should be able to identify the carrier waves of broadcasting stations. There will, however, be no distinguishable speech or music as the receiver is in an oscillating condition. If it is desired to hear speech or music the set must be removed from its oscillating condition, but this reduces its sensitivity. Therefore, the procedure is as follows: locate a carrier wave (a rising and falling whistle) and stop at the silent point where the whistle changes its pitch. Then very carefully slacken off the reaction control, and if the station is not too weak the speech or music will become distinguishable.

Adjusting the Set.—First of all, if you find, on rotating the reaction dial, that the set does *not* start oscillating with that faint hiss that I have already mentioned, but does so with a loud and painful plop, look for the following causes: (a) accumulator needs charging; (b) voltage on H.T.1 too high for the particular detector valve you are using. Reduce gradually until you find the best position.

If, instead of the plop it develops a musical howl or hoot, the following remedies are sure to include one that stops it: (a) reduce high-tension again; (b) connect a small fixed condenser (above .0005) directly across the telephone terminals at the rear of the set; (c) use a resistance of $\frac{1}{2}$ -megohm or even $\frac{1}{4}$ -megohm across the secondary terminals

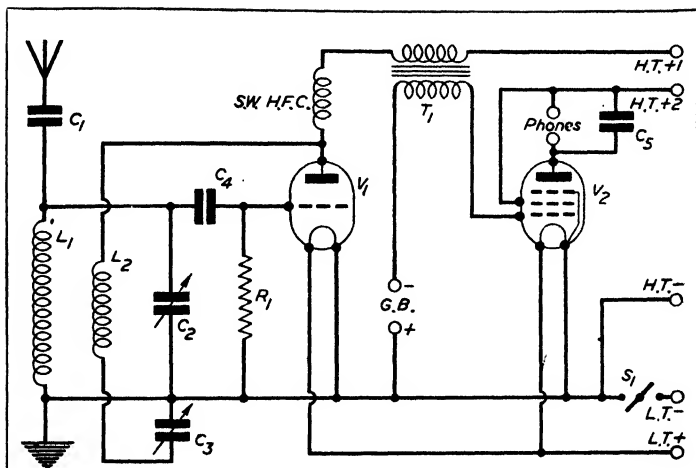

FIG. 34.—Circuit No. 15 for Midget Short-Wave Two.

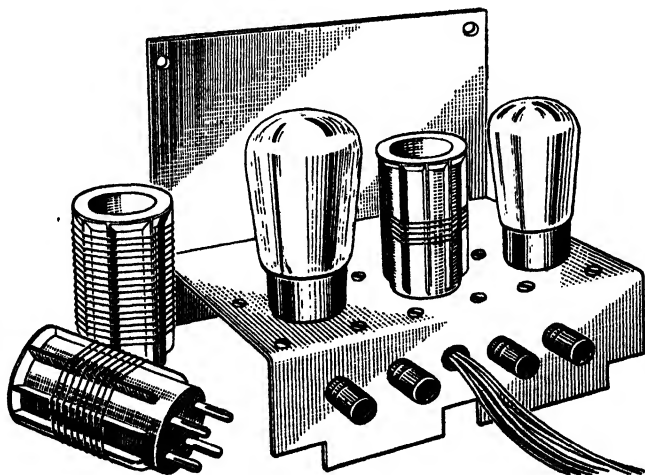

FIG. 35.—The Midget Short-Wave Two as built (Circuit No. 15).

of the L.F. transformer, in place of the 1-megohm leak already shown there. It will be as well to use a leak of the clip-in type for this purpose in case such an alteration has to be made.

Coils.—All the diagrams of this set show the arrangement that is used for the particular set of short-wave coils that were employed in the original set.

Fig. 32, showing the coil base and a specimen coil, is sufficiently clear to need no extensive description.

Two windings are wound straight on a 2-inch paxolin tube. The wire is No. 22 enamelled, and it is "close-wound." About $\frac{1}{2}$ inch should be left between the two windings, which must, of course, be in the same direction.

Looking at the former with the "grid" pin (the pin separated from the other three) at the left-hand end, the "grid" winding should be commenced there, with its commencement taken to that pin. The end of the winding goes to the "filament" pin, at the other end. The reaction winding is then started. The end nearest to the "grid" winding goes to the terminal marked "H.T." and the far end goes to the remaining terminal, marked "P." or "Plate."

The numbers of turns for the 3 coils are: coil 1—grid 3 turns, reaction 2 turns; coil 2—grid 6 turns, reaction 5 turns; coil 3—grid 18 turns, reaction 12 turns.

In addition to these two windings mount an aerial coil in such a way as to swing towards the other, at the "filament" end. This consists of four turns, also of 2 inches diameter, and remains the same for all three wavelength-bands.

LIST OF COMPONENTS FOR CIRCUIT NO. 14

1 bakelite or ebonite panel, 14 in. × 7 in.	1 L.F. transformer.
1 cabinet for same, with base-board 7 in. deep.	1 3-megohm grid leak with clips.
1 set of short-wave coils, with base ("Air-King," Rothermel Corporation).	1 1-megohm grid leak with clips.
2 valve-holders.	1 .0002 fixed condenser.
1 .0003-mfd. variable condenser.	1 H.F. choke.
1 .0001-mfd. variable condenser.	1 ebonite strip with 8 terminals.
	1 L.T. switch.
	2 slow-motion dials.
	Insulated or tinned copper wire, wood screws, etc.

Circuit No. 15.—In Fig. 34 is shown the circuit for a midget short-wave two. Like most short-wave sets it is straightforward. The aerial input signal is taken through a .0001 mfd. fixed condenser C.1 to the top of the aerial

tuning coil L.1. This coil together with the reaction coil L.2 is wound on a small diameter ribbed 4-pin former. The turns are spaced and wound with 22-gauge enamelled wire, the ribs being slotted to ensure coil rigidity. The ranges for the coils, if such are purchased, are as follows: 10 to 21 metres, 18 to 37 metres, and 33 to 77 metres. This covers the most important of the short-wave transmissions including those stations which can be readily received under normal conditions. The first valve V.1 is a leaky grid detector and the reaction feed from the anode of this valve is *via*

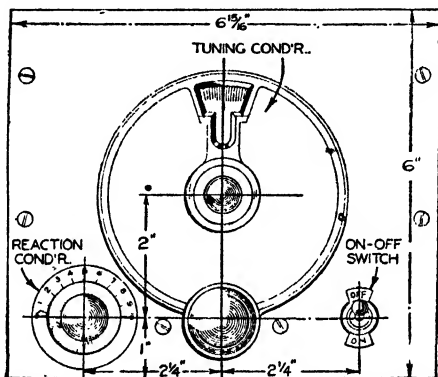

FIG. 36.—Drilling details for the Panel for Circuit No. 15.

coil L.2 and variable condenser C.3. For short-wave reception it is absolutely essential to have a really smooth reaction control, and, apart from the necessity of ascertaining the correct detector anode voltage to ensure this, a fine degree of accuracy is required in the reaction control. Erratic or coarse motion must be avoided, and then it is possible to bring in the weak signals which would otherwise not be possible. By having a calibrated scale and a ten-to-one reduction in its drive, the condenser employed in the actual receiver has proved most reliable.

Another factor which has to be watched in the case of a short-wave set is the high-frequency choke. First of all it must be free from any resonance peaks in the wavelength range covered, and the turns so spaced that they have a very low self-capacity. The component chosen embodies these two points, being wound as four small honey-

comb coils on a special hollow former. Compactness and a small external field is thus assured, while the wire ends enable it to be mounted directly in the under-chassis wiring.

By employing a compact low-frequency transformer it is possible to accommodate this component below the chassis, while the ratio chosen gives just the right amount of step-up for a circuit of this character. Finally, we have the pentode output valve V.2 giving the additional power required when listening to the more distant stations. (See Figs. 35 to 38 for details of construction.)

LIST OF COMPONENTS FOR CIRCUIT NO. 15

- 3 4-pin coils.
- 1 L.F. transformer, 5/1.
- 1 on-off switch.
- 1 3-megohm grid leak.
- 1 .0001 mfd. microdenser.
- 3 chassis mounting valveholders (5-pin).
- 1 .0001 mfd. condenser.
- 1 .001 mfd. condenser.
- 1 short-wave H.F. choke 10/200 metres.
- 1 .0001 mfd. condenser.
- 1 slow motion drive.
- 1 .0002 mfd. slow-motion reaction condenser.
- 4 small type terminals, A, E, and 2 phones.
- 5 midget wander plugs, H.T. +2, H.T. +1, H.T. -, G.B. +, and G.B. -, and 2 spade tags L.T. +, and L.T. -.
- 1 aluminium chassis, panel, and cabinet (sprayed black).
- 2 valves, detector, and 1 pentode.

Circuit No. 16.—In this receiver a Cossor 240 B valve is used as a detector in place of the twin 210 H.L. valves specified for Circuit No. 17. It is interesting to record that the set as originally described proved itself capable of picking up Philadelphia, U.S.A., on the medium wave-band, at audible strength on the loud-speaker; this is good evidence of its sensitiveness, considering that it has no screen-grid stage, only one tuned circuit, and one L.F. stage. Naturally the volume from this station was not sufficient for ordinary use, but a screen-grid valve before the twin detectors would probably remedy this.

Fig. 39 shows the circuit diagram, employing one Class B valve as detector instead of two separate triode valves.

Varying Grid Potentials.—It will be observed that a tuned

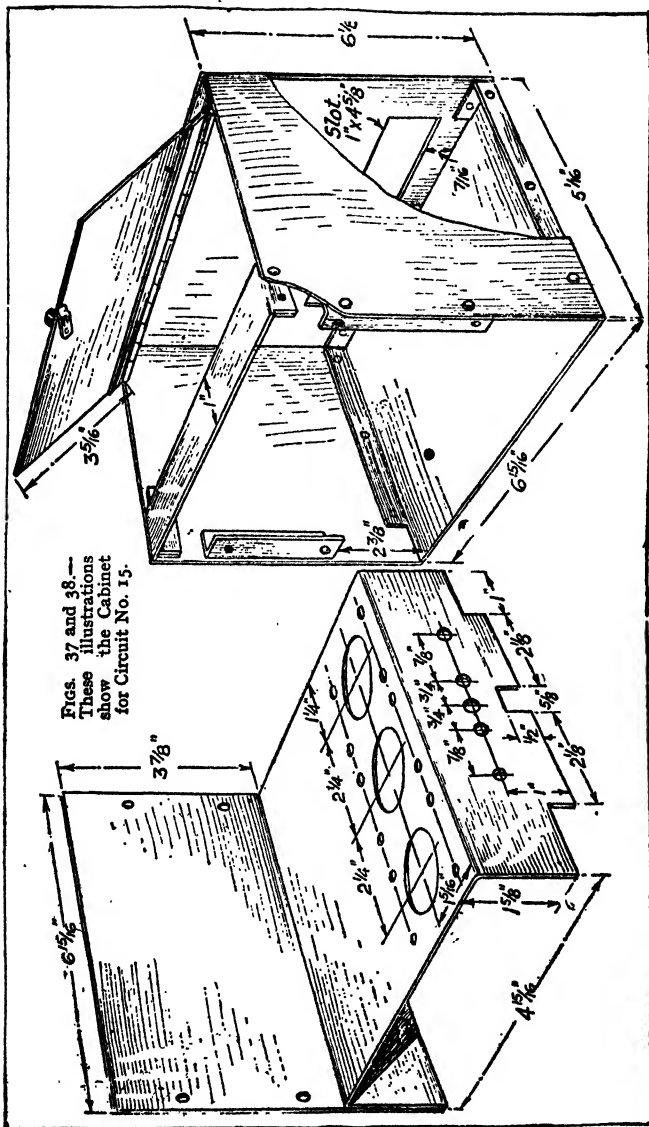

Figs. 37 and 38.—
These illustrations
show the Cabinet
for Circuit No. 15.

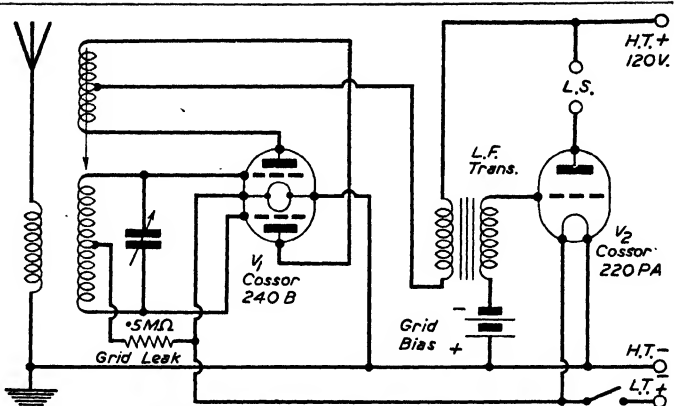

FIG. 39.—Theoretical Circuit of the Class B Detector Two-Valver.

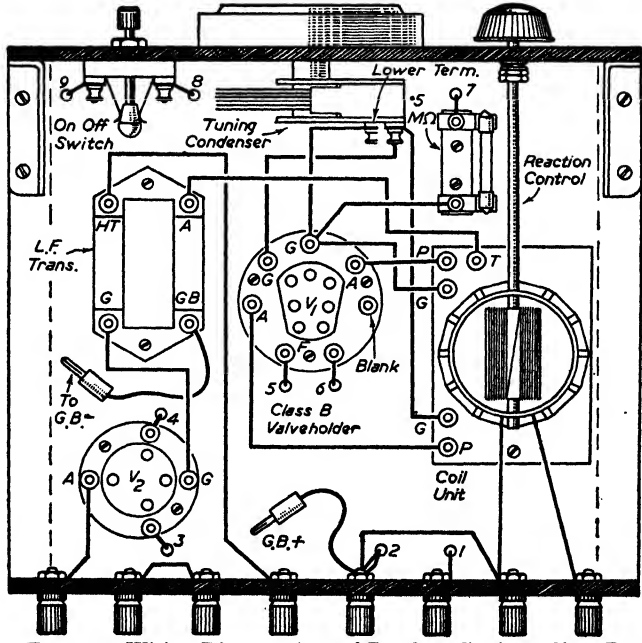

FIG. 40.—Wiring Diagram (top of Baseboard) of the Class B Detector Two-Valver.

circuit is connected between the two grids and that this grid circuit is isolated from the rest of the wiring, except for the grid leak; also notice that there are no grid condensers at all. The grid coil is energised by magnetic induction from the aerial coil, so that the oscillating current in the circuit charges one grid negatively at the same instant that the other grid is positively charged. The two grid potentials are therefore always exactly half-a-cycle out of step with each other, consequently the H.F. component of the current from their respective anodes is also half a cycle out of phase. Now the two anodes are connected (after the push-pull reaction coil) to a common output, and in this output the

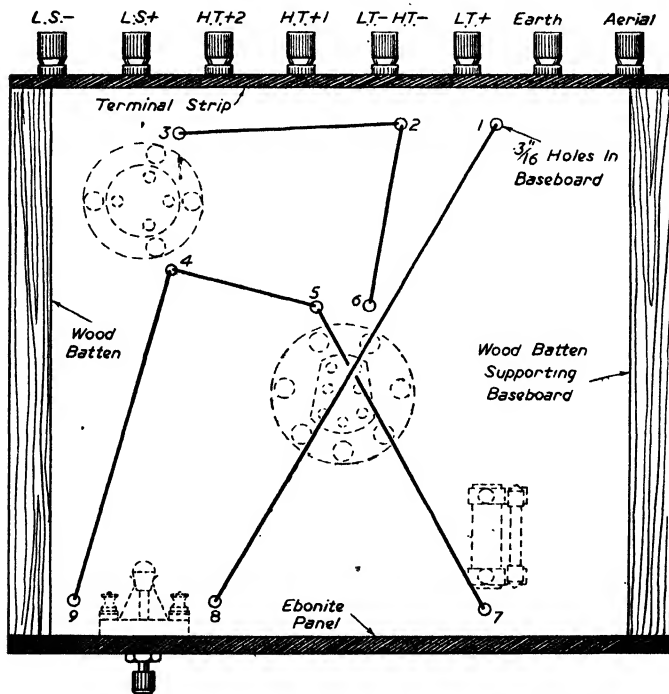

FIG. 41.—Sub-Baseboard Wiring Diagram of the Class B Detector Two-Valver.

out-of-step H.F. components from the two anodes neutralise each other and disappear, leaving only the L.F. variations, which are then passed on through a transformer in the usual manner.

Method of Detection.—Detection is carried out by the action of grid current, which causes the *mean* potential of the whole grid circuit to fluctuate in accordance with the audio-frequency modulations and the grid-leak functions in the usual manner by giving the grid system a definite tendency to return to a mean potential of zero. The usual system of detection, using one valve with grid leak and condenser, introduces a damping effect on the tuned circuit, which is very much reduced in the push-pull system. The minimum damping effect will be obtained with the grid leak connected to a centre-tapping on the grid coil, as shown in Fig. 39, but in practice the system seems to work just as well with the grid leak connected to one end of the coil, as shown in the circuit diagram of the receiver as originally described. The effect of this reduced damping is to render the set more sensitive and more selective. Even with the home-made coil the P.P. detector set shows up well on these points, but if the makers of "iron dust" and similar coils could be induced to make a special coil for this circuit some wonderful results might be achieved. (Figs. 40 and 41 show wiring diagrams.)

H.T. Voltage.—The Class B valve was found to require a somewhat higher anode voltage than the original twin triode detectors. The best results were obtained with about 90 volts instead of 72 volts for the twin 210 H.L. valves. Except for this point, there appears to be very little difference as far as operation and performance is concerned. If anything, the new valve gives rather more volume on local and distant stations, and the tuning is perhaps a little less sharp; the difference, however, is very slight, and is chiefly noticeable in the case of the local station which has a little more "spread" with the Class B valve.

Reaction Control.—The reaction control is best set at zero for local stations up to a distance of 50 miles or so from a Regional or National, and probably only a little will be required above this. The Continentals require plenty of reaction to bring them in at good strength.

Circuit No. 17.—A glance at the circuit diagram (Fig. 42) will show that this set is very much out of the ordinary in the respect that it has twin detector valves but no grid

condensers. The result is that the circuit is an extremely simple one, requiring a minimum of components. With the

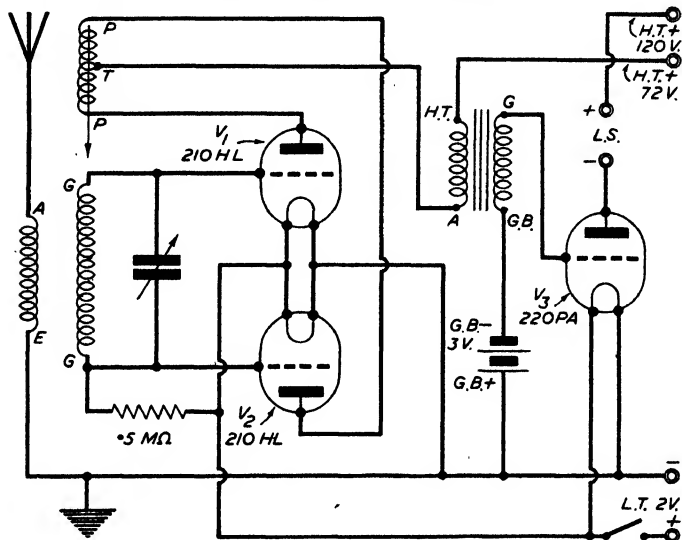

FIG. 42.—Circuit No. 17 of the Push-Pull Detector Two-Valve.

single stage of amplification, as specified, good loud-speaker results have been obtained in the north midlands from over thirty stations, the continentals coming in particularly well on the medium wave-band. Long waves have not given such good results. Moderate results can be obtained from a separate long-wave coil, but a really satisfactory dual-wave switch-over coil for this set remains to be produced.

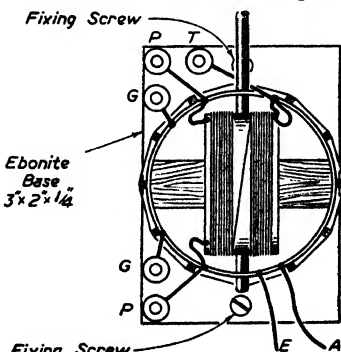

FIG. 43.—Showing the Construction of the Special Coil.

It is essential to adhere to the components specified. The transformer, for instance, has a particularly high primary inductance, and gives definitely better results than a cheap transformer.

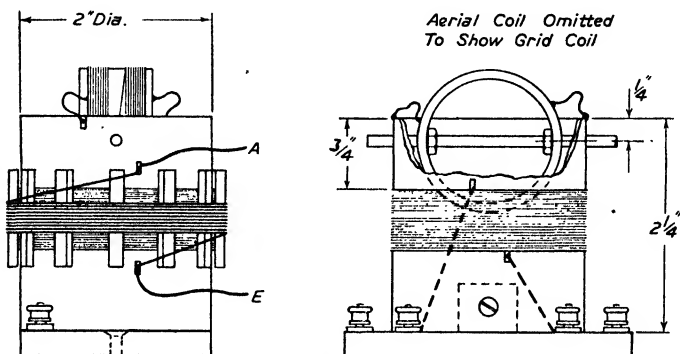

FIG. 44.—Further details of the Coil.

Also, if other valves are used, it may be found that it will be necessary to alter the number of turns on the reaction variometer. Reaction is frequently supposed to be unsatis-

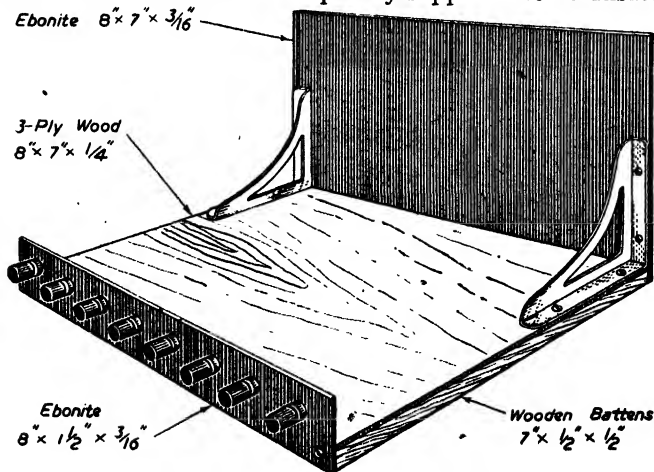

FIG. 45.—The Chassis Construction.

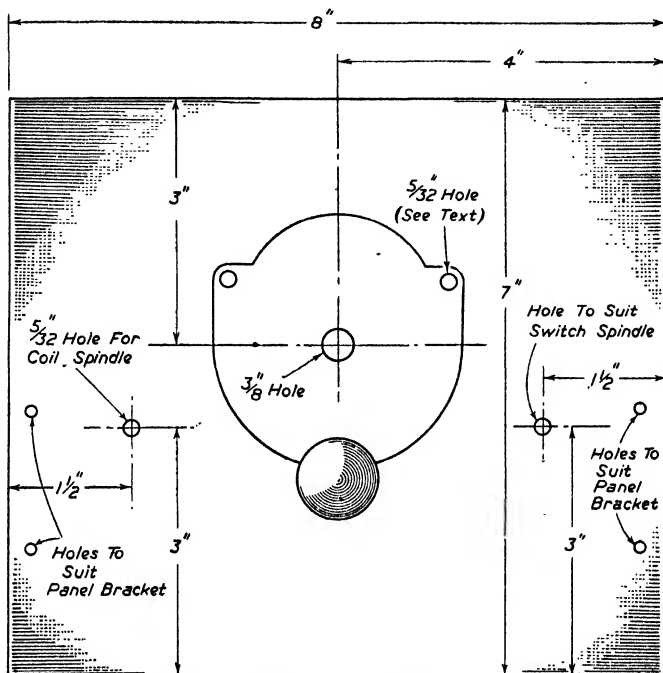

FIG. 46.—How to drill the Panel for the Push-Pull Detector Two-Valver

factory with push-pull detection, on account of distortion, but in applying the push-pull principle by means of a variometer in the manner described, very satisfactory results can be obtained.

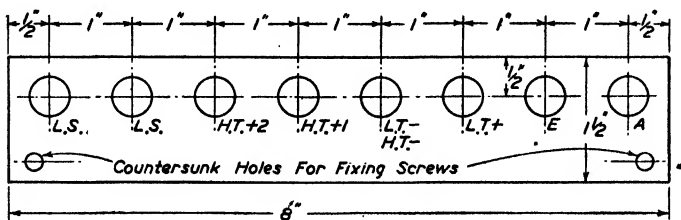

FIG. 47.—The Terminal Strip.

Making the Tuning-Coil.—A special home-made coil is required, so it will perhaps be advisable to get this component made before commencing to assemble the receiver. Fig. 43 shows how this coil is to be made. The former consists of a piece of cardboard tube 2 inches outside diameter and $2\frac{1}{2}$

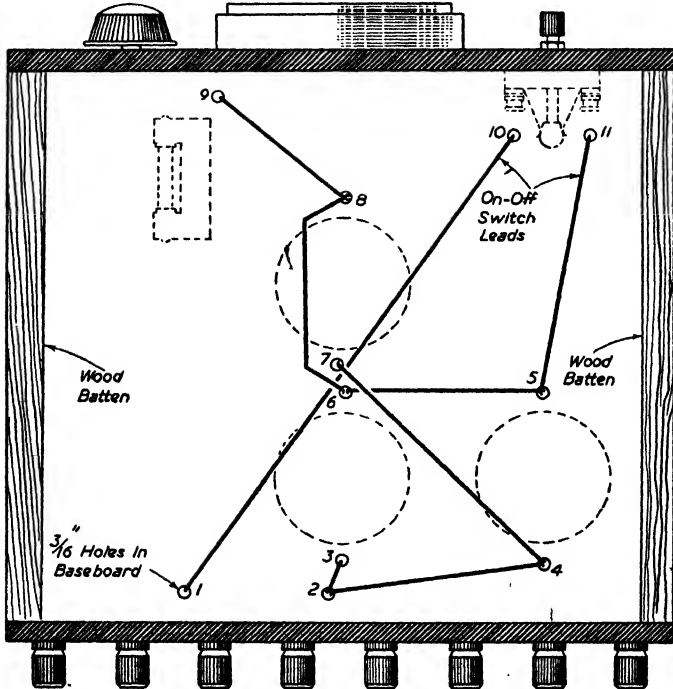

FIG. 48.—Sub-Baseboard Wiring Diagram for the Push-Pull Detector Two-Valver.

inches long. This is fixed to an ebonite base by means of a piece of wood about half an inch square, fixed across the bottom of the tube by a screw at each end, and two screws through the ebonite from underneath.

The tuned grid coil is wound direct on to the former, commencing $\frac{1}{4}$ of an inch from the top. It consists of fifty-five turns of No. 36 double silk covered wire; fix the ends by threading the wire three or four times through two small

holes about $\frac{1}{8}$ of an inch apart. Run the ends down the inside of the tube and then out to the two terminals marked "G." Now, cut twelve pieces of wood $\frac{1}{8}$ of an inch square and 1 inch long (good sound matches will do) and arrange these equidistantly round the former over the grid coil, and

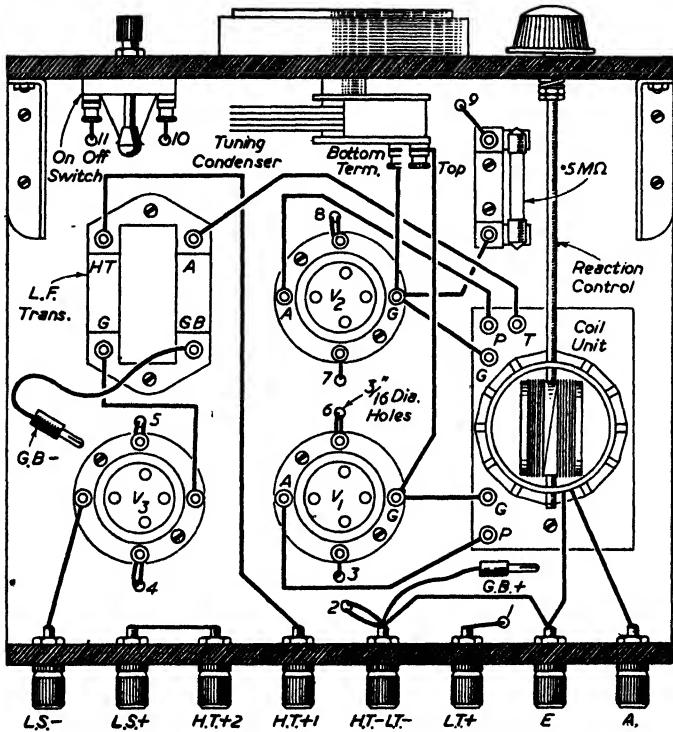

FIG. 49.—Baseboard Wiring Diagram of the Push-Pull Detector Two-Valver.

fix them to the former with a touch of secotone or other adhesive at each end. Wind the aerial coil on top of these pieces, as shown in Fig. 44. Use 28 gauge enamelled wire for this, and put on 12 turns; fix the ends as you did for the grid coil, but do not attach the ends to terminals and leave about 3 inches free and run these ends straight to the aerial and earth terminals of the set.

Reaction Variometer.—The reaction variometer is a piece of ebonite tube $1\frac{1}{2}$ inches diameter by $\frac{3}{4}$ of an inch long, and its spindle is a 6-inch length of 6 B.A. screwed brass rod. Drill $\frac{1}{8}$ of an inch holes in the ebonite for the spindle, which can then be screwed into place without tapping the holes; lock the ebonite tube to the spindle with two 6 B.A. brass nuts, as shown. Use similar wire to the grid coil for the winding; drill the ebonite with the $\frac{1}{16}$ in. holes in three places, as shown, and fix the end of the wire (leaving about $1\frac{1}{2}$ inches free) by threading it two or three times through the hole and over the edge of the ebonite. Wind on 8 turns of wire on one side of the spindle, then lead the wire across and put 8 more turns on the other side; double the wire to form a loop about $1\frac{1}{2}$ inches long, and fix this loop by carefully threading it through the $\frac{1}{16}$ in. hole already provided. This forms the centre tapping. Now, continue winding in the same direction as before, and put on 8 more turns over the second 8, lead the wire across to the other side of the spindle and put on another 8 turns over the first 8, and finish off at the unoccupied $\frac{1}{16}$ in. hole. This makes 32 turns altogether on the variometer. A few touches of glue should be put on the coils to fix them.

Fix three pieces of 28 gauge wire at the top edge of the cardboard former, and run them down inside the former to the three terminals P, P, and T. Fix the variometer to the former tube (it will, of course, be necessary to remove the spindle to do this); then solder the three connections on the variometer to the three wires leading to the terminals; be particularly careful to see that the double connection forming the centre tapping connects to terminal marked T, and loop up the wires as shown on the illustration to allow the variometer to move 90° each way from the position shown. The coil is then finished.

Build up the chassis as shown in Fig. 45. This is quite a straightforward job and needs no detailed description. The underside of the base will be a shallow box; this simplifies the wiring, because the low-tension circuit can be wired underneath the base, all other wiring being on top. Figs. 46 and 47 show the drilling dimensions for the panel and for the terminal strip respectively.

Fixing the Components.—The fixing of the components presents no difficulty, their positions being shown in Figs. 48 and 49, which also shows the wiring above the base. The wiring below the base is also shown. When fixing the

coil a little care is necessary to see that the variometer spindle lines up with the hole in the panel; the spindle should project through about $\frac{3}{8}$ of an inch, and a suitable knob with a grub screw fixing obtained from some old component. Two 6 B.A. lock-nuts and a spring washer behind the panel will serve to introduce a little friction so as to cause the variometer adjustment to "stay put."

The slow-motion dial goes entirely on the front side of the panel and is fixed by the two bolts provided with the dial. Fix the condenser first by means of the usual one-hole fixing so that its terminals are vertically above each other, then put on the slow-motion dial and hold it in position by hand while you mark the position of the two bolt-holes on the panel. Then remove the dial and drill the two holes $\frac{5}{16}$ in. diameter; this is a good deal larger than necessary for the bolts, but will allow the dial to find its own position, otherwise it may not work freely. The resistance of the grid leak is rather lower than usual, but the value does not appear to be critical; the detector works just as well with 1 megohm or $\frac{1}{2}$ megohm, but the lower resistance reduces hand-capacity effects when tuning.

Use the 72-volt tapping for the detector high-tension, unless you want to experiment. If the 90-volt tapping is used the set will be a little more sensitive, but there may be some distortion due to transformer saturation, and the reaction will be found too fierce for convenience. The power valve (Cossor 220 P.A.) should have 120 volts on the anode and 3 volts grid bias.

LIST OF COMPONENTS FOR CIRCUIT NO. 17

- | | |
|---|---|
| <ul style="list-style-type: none"> 1 ebonite panel, 8 in. x 7 in. x $\frac{1}{8}$ in. 1 ebonite terminal strip, 8 in. x $1\frac{1}{2}$ in. x $\frac{1}{16}$ in. 1 3-ply baseboard, 8 in. x 7 in. x $\frac{1}{4}$ in. 2 wood battens, 7 in. x $\frac{1}{2}$ in. x $\frac{1}{2}$ in. 2 panel brackets. 1 bakelite tuning condenser, .0005. 1 slow-motion dial. 1 coil made as instructed. 1 R.I. Hypermite transformer. 1 grid-leak holder. 3 valve-holders. 1 grid-leak, $\frac{1}{2}$ megohm. 1 on-off battery switch (2 point). 8 terminals marked as shown. 1 coil connecting wire. | <ul style="list-style-type: none"> 1 short length of flex for grid-bias connection. 1 length screwed brass rod, 6 B.A., and 2 nuts. 2 doz. brass screws, $\frac{1}{2}$ in. x No. 4 countersunk heads. <p><i>Cost of above should not exceed 30s</i></p> <p style="text-align: center;">ACCESSORIES</p> <ul style="list-style-type: none"> 2 Cossor 210 H.L. metallised valves. 1 Cossor 220 P.A. power valve. 1 6-volt grid-bias battery. 1 120-volt H.T. battery 1 2-volt accumulator. 4 wander plugs—G.B. +, H.T. + H.T. +2, H.T. -. |
|---|---|

Circuit No. 18.—The building of a receiver for ultra-short waves has always been considered as a job quite apart from the construction of a standard broadcast receiver. So much so, that experimenters who required a set for S.W. work have almost invariably found it necessary to employ a separate set for the purpose whilst keeping another for broadcast reception. A number of constructors have tried

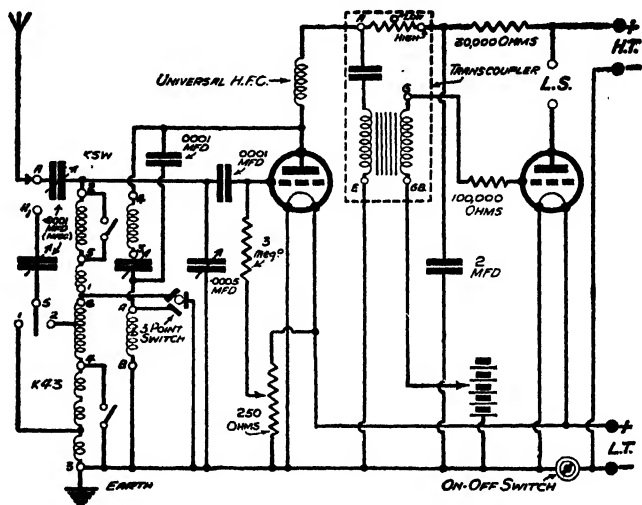

FIG. 50.—The Circuit Diagram of the Four-Range Two-Valver (Circuit No. 18).

to combine the two functions in a single instrument, but in very few cases have the results been really satisfactory. (see Fig. 50).

General Considerations.—It is well known that any loss in efficiency is much more pronounced on short waves, and, therefore, in designing a set for this purpose the aim must always be to eliminate any possible source of loss. This is not difficult when making a set for laboratory or experimental use, but when the set has to be installed in a drawing-room things are rather different. In working out the design of the four-range two, the first consideration was to make an S.W. receiver which was sufficiently compact and neat, whilst being as good as the best experimental model. When

this had been done, gradual modifications were introduced so that the same set could be used successfully for reception on the longer wavelengths. Without enumerating all the difficulties encountered, it can be said that this ideal was eventually reached without detracting in any way from the efficiency on S.W. Perhaps the greatest difficulty was in obtaining a satisfactory system of switching from one waveband to another without incurring capacity losses in the wiring. This was solved by employing coils with self-

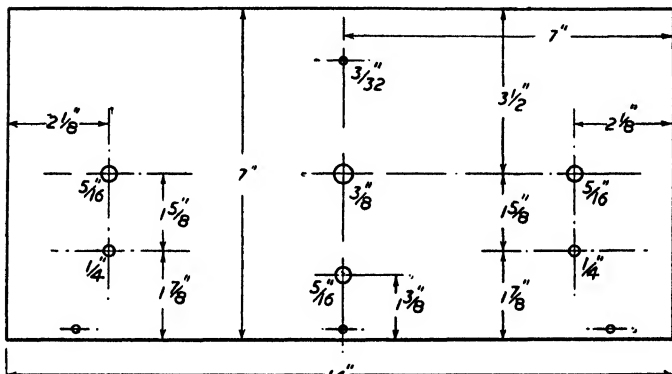

FIG. 51.—The Panel Layout of the Four-Range Two-Valver.

contained switches, with a result that the only other switch required was a simple 3-point one, and the additional wiring almost negligible.

As the name implies, the four-range two is a two-valver, designed to cover four different tuning ranges, and giving a high degree of amplification. The ranges covered, by the way, are from 18 to 35 metres, 30 to 65 metres, 220 to 550 metres, and 900 to 2200 metres. Efficiency and the degree of magnification are equally high on all four wavebands, and in this respect the set stands out as being somewhat unique.

Selectivity and Range.—As a broadcast receiver pure and simple, it is better than most two-valvers both as regards selectivity and range of reception. It will bring in at least fifteen stations on the loud-speaker, even when used within

20 miles of a pair of Regional Transmitters, and at such a range the tuning of each of the latter stations does not extend over more than 10 degrees or so. On the short wave-bands it is sufficiently sensitive to bring in a number of Continental and American stations at loud-speaker strength, whilst when using 'phones the expression "distance no object" is most apt. Under all conditions tuning is remarkably easy, and reaction control beautifully smooth. The final appearance of the set is very "clean" and symmetrical; but, as previously mentioned, it has passed through many experimental stages, so intending constructors are specially requested not to try to "improve" it by using different components or by altering the lay-out to suit some convenient cabinet. All the parts have been chosen after careful experiment, and their best positions have been determined by patient trial, and as the result of a long experience.

Coil Assembly.—The coil assembly is the most important item, and it has been specially made up for this set by Messrs. Colvern at my request. It consists of two separate screened coils, each fitted with a self-contained wavechange switch and with both switches operated by a single-ganged drive. One coil is a special S.W. one and the other is a broadcast coil with two aerial tappings; another switch contained in the base of the latter coil automatically connects the aerial to an appropriate tapping for medium or long-wave reception. When the set is required for operation on the two higher wave-bands, both windings (grid and reaction) of the two coils are in series, but when listening on short waves the windings of the broadcast coil are short-circuited by a 3-point switch. Tuning is by a single knob, which operates a .0005-mfd. condenser having a 35 to 1 reduction drive, thus making accurate tuning easy of accomplishment even on the highest frequencies.

Both coils have reaction windings, which are used in conjunction with a variable condenser. A .0001-mfd. reaction condenser is sufficient for S.W. reception, but for the broadcast bands approximately twice that capacity is necessary. In order to satisfy both these conditions in the most satisfactory manner, a .0001-mfd. variable reaction condenser is used, and functions independently on S.W. When the 3-point switch is pushed "in," however, a fixed condenser of similar capacity is put in parallel with it. With this very simple arrangement reaction control is delightfully easy on every wave-band.

Other Components.—Two aerial terminals are provided, one for S.W. work and the other for broadcast reception. Each is connected to the appropriate coil through a separate

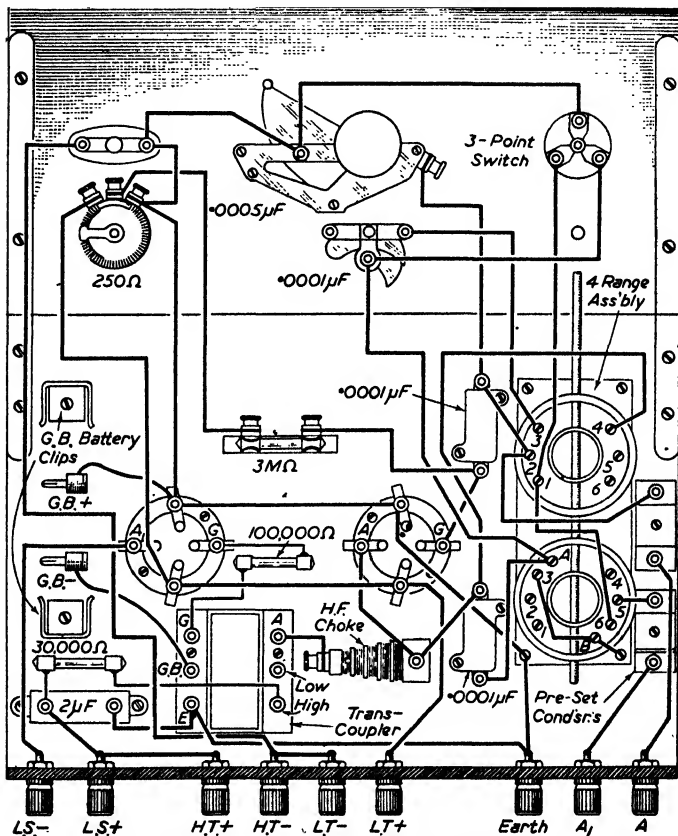

FIG. 52.--Wiring Diagram of the Four-Range Two-Valver.

pre-set condenser, so that the optimum setting can be found and retained for long and short waves. The detector valve (a good one for high amplification) operates on the usual leaky-grid system, although the values of grid condenser and leak are rather unconventional; values were chosen which

proved to be equally satisfactory for each wave-band. The grid leak is taken to the slider of a 250-ohm potentiometer, wired across the filament supply, so that exactly the correct grid voltage can be applied under all conditions. The potentiometer can be left in almost any position for more or less local reception, but it is extremely valuable when carrying out long-distance or S.W. reception. The H.F. choke has to deal with all wavelengths, and that chosen is specially designed for this purpose.

Instead of the usual L.F. transformer, a "Transcoupler" is employed which combines a high-efficiency transformer with a parallel resistance-capacity anode-feed circuit. The arrangement makes for "straight-line" amplification of all frequencies, besides giving a greater degree of amplification due to the absence of D.C. current in the primary windings. A decoupling resistance and condenser are used to feed the transcoupler, so preventing motor-boating and L.F. feed-back. A 100,000-ohm non-inductive resistance (actually a metallised one) is inserted in the grid lead of the power valve to prevent the passage of any stray H.F. currents into the amplifier. The power-valve chosen is one of the newer high-efficiency types, which gives a very high degree of magnification on a small anode current.

Practical Details.—A plywood panel is specified in the list of components, but an ebonite one may be used in its place, if desired. The plywood is, of course, cheaper, and is possibly the best material, because it can be finished in such a variety of ways to match cabinets or furniture. The position and diameters of the panel holes are given in Fig. 51. Details of the construction and wiring are most easily obtained from Fig. 52. All wiring is in insulated wire, which can be attached to the terminals after baring the ends by looping and fitting it under the nuts. It might not be quite clear from the wiring plan that two connections are made to the aluminium baseplate of the coil assembly. These are made by looping the wires round the holding-down screws before tightly screwing down the latter. These two connections slightly simplify the wiring and, of course, serve to "earth" the entire screening system. The two leads to the grid-bias wander plugs are made with flex, so that they can be moved more easily. Little need be said of the other wiring, since this is perfectly straightforward.

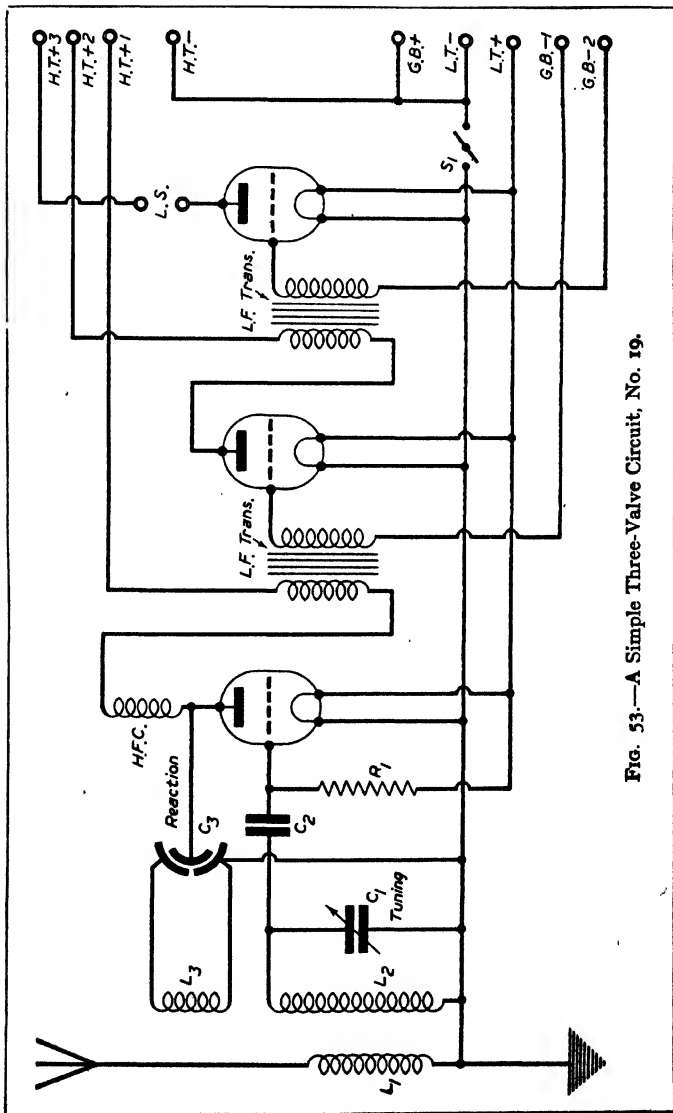

Fig. 53.—A Simple Three-Valve Circuit, No. 19.

LIST OF COMPONENTS FOR CIRCUIT NO. 18

- | | |
|--|---|
| <ul style="list-style-type: none"> 1 plywood panel, 14 in. by 7 in. 1 baseboard, 14 in. by 9 in. by 10 in. 1 pair panel angle brackets. 1 ebonite terminal strip, 14 in. by 1 in. by $\frac{1}{2}$ in. 1 ebonite panel, 14 in. by 7 in. 9 terminals, marked A, A1, Earth, L.T.+, L.T.-, H.T.-, H.T.+, L.S.+, L.S.-. 1 '0005 mfd. variable condenser with slow-motion drive. 1 dial indicator. 1 '0001 mfd. reaction condenser. 1 2-spring battery switch. 1 3-spring wavechange switch. 1 250 ohm potentiometer. 1 set "Four Range" coils; supplied complete with ganged aligned switches and base-plate (Colvern "Four-Range"). | <ul style="list-style-type: none"> 2 '0001 mfd. (max.) pre-set condensers. 1 3-megohm grid leak. 1 grid leak holder. 2 '0001 mfd. fixed condensers. 2 low-loss valve holders. 1 universal H.F. choke. 1 L.F. transcoupler. 1 30,000 ohm spaghetti resistance. 1 2 mfd. fixed condenser. 1 100,000 ohm metallised resistance. 1 pair G.B. battery clips. 2 wander plugs, marked G.B. + and G.B. -. 2 coils insulated wire, odd lengths flex, $\frac{1}{2}$-in. screws. 2 valves (Cossor 210 H.L. and 220 P.A.). 1 cabinet. |
|--|---|

Circuit No. 19.—Fig. 53 shows a very simple three-valve set, consisting of a simple detector followed by two transformer coupled L.F. stages. The first transformer should be of low or medium ratio, say 2·7 or 3 to 1, and the second may be of the 5 to 1 type. Plug-in coils are employed for tuning, and the remarks on Circuit No. 4 are also applicable to the detector side of this circuit. The valves required are detector, L.F., and power, the first valve having about 60 volts H.T., the second 100 volts, and the last, or power, valve having the maximum which the makers recommend. As mentioned in regard to previous circuits, pay particular attention to the adjustment of the grid bias, as you will thereby prolong the life of both H.T. battery and valves.

LIST OF COMPONENTS FOR CIRCUIT NO. 19

- | | |
|---|--|
| <ul style="list-style-type: none"> 1 '0005-mfd. variable condenser (C₁). 1 '0002-mfd. fixed condenser (C₂). 1 '0002 differential reaction condenser (C₃). 1 2-megohm grid leak and holder (R₁). | <ul style="list-style-type: none"> 1 H.F. choke. 2 L.F. transformers. 3 valve-holders. 3 coil-holders. 1 on-and-off switch (S₁). Set of plug-in coils. Terminals, connecting wire, and screws. |
|---|--|

Circuit No. 20.—In this circuit, the first transformer has been substituted by a resistance-capacity coupling arrangement (Fig. 54).

Circuit No. 21.—In this arrangement (Fig. 55), a special type of L.F. coupling has been incorporated. This is known as an auto-transformer, and it gives a large step-up in voltage, besides being very good from the purity point of view. In

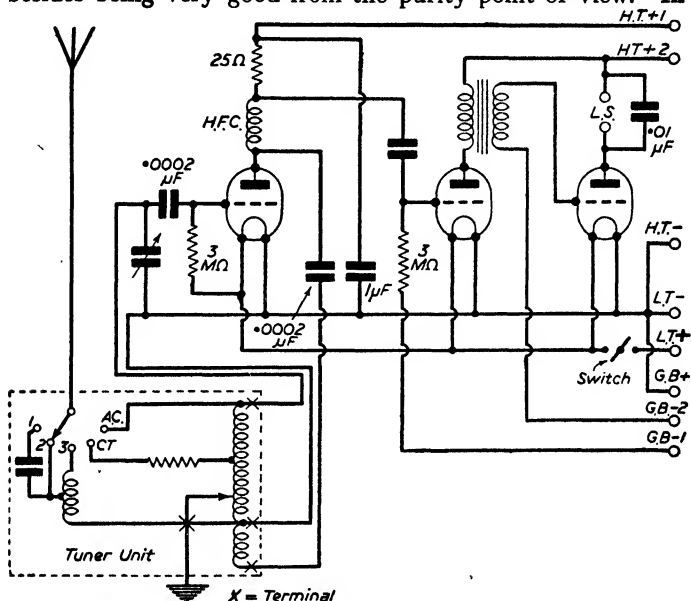

FIG. 54.—A similar Circuit to Fig. 53, except that it employs Resistance Capacity Coupling.

other respects the receiver is similar to the two preceding sets. To make this receiver selective, a special form of band-pass tuner is employed, and this is made by the same firm that makes the auto-transformer.

LIST OF COMPONENTS FOR CIRCUIT NO. 21

- | | |
|--|--|
| <ul style="list-style-type: none"> 2 .0005-mfd. variable condensers (C1 and C2). 1 square peak tuner. 1 .04-mfd. non-inductive condenser (C4). 1 .0002-mfd. fixed condenser (C3). 1 2-megohm grid leak and holder (R1). 1 30,000-ohm resistance and holder (R2). | <ul style="list-style-type: none"> 1 .5-mfd. fixed condenser (C5). 1 auto-transformer. 1 low-ratio L.F. transformer. 3 valve-holders. 1 on-and-off switch (S1). Terminals, connecting wire and screws. 1 .0001 reaction condenser (C6). |
|--|--|

Circuit No. 22.—With the production of very small components has come the demand for a small and light-weight portable. Previously, receivers which masqueraded under the title of portable were in many cases heavier than a table receiver. You can now obtain midget speakers, valves, accumulators, H.T. batteries, transformers, tuning coils, variable condensers, and so on. Although this receiver is small it will receive a large number of stations at comfortable loud-speaker strength. It is an ideal receiver for cyclists, hikers, motorists, or for use on the river, picnicking, etc. It will be seen from Fig. 56 that there are three valves—a screen grid acting as H.F. amplifier, a triode as detector, and a pentode in the output stage. There are two tuned circuits, the frame aerial winding being tuned by a $\cdot 0005$ mfd. variable condenser, whilst the inter-valve coil is tuned by a second $\cdot 0005$ mfd. variable condenser. The reaction winding is arranged on this inter-valve coil, thereby considerably simplifying the construction of the frame aerial. I have made provision for a throw-out aerial to improve selectivity, although within normal distances of a broadcasting station, this is not necessary. A chassis is employed and the components are mounted on the sub-chassis principle. A wooden panel is attached to the front of the chassis to carry the speaker and to provide the necessary rigidity for the very light cabinet. This wooden panel also carries the frame aerial winding which is pile wound.

Coming now to the actual constructional work, this will be found extremely simple (see Figs. 57 and 58), and at the same time interesting, on account of the slightly novel form taken by this particular receiver. The accompanying illustrations show that the frame aerial is wound on the panel, and the theoretical diagram shows that the coil and the L.F. transformer are provided with colour-coded leads in place of the more usual terminals. This has been done in order to reduce weight and to avoid making extra connections, as the makers have already connected leads to the components and as shown in the diagram (Fig. 59) these are coloured for identification. The chassis is supplied by the makers ready drilled and the only components to be mounted upon it are the L.F. transformer, valve-holders, and the coil. Nuts and bolts should be used for these, and the tuning and reaction condensers which are mounted on the front should not be attached until the panel has been finished. Therefore, the wiring should be commenced as

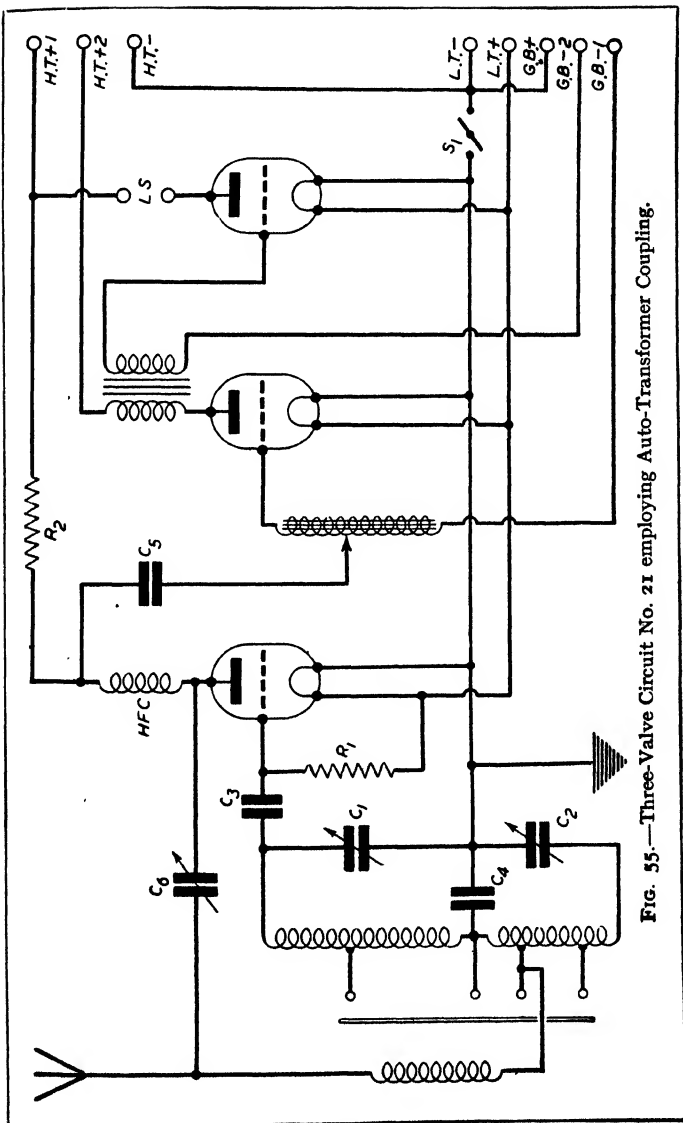

Fig. 55.—Three-Valve Circuit No. 21 employing Auto-Transformer Coupling.

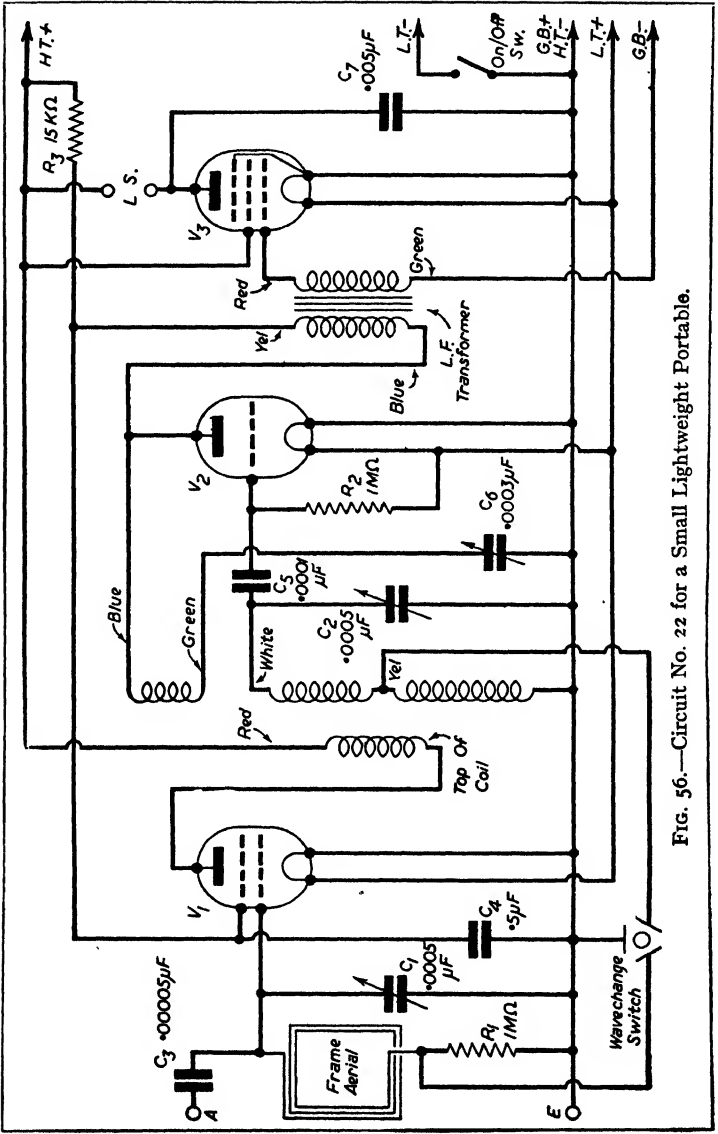

FIG. 56.—Circuit No. 22 for a Small Lightweight Portable.

soon as the three main chassis-mounted components have been fitted in position.

It will be noted that the frame aerial is wound on screws fitted to the front of the wooden panel. An alternative

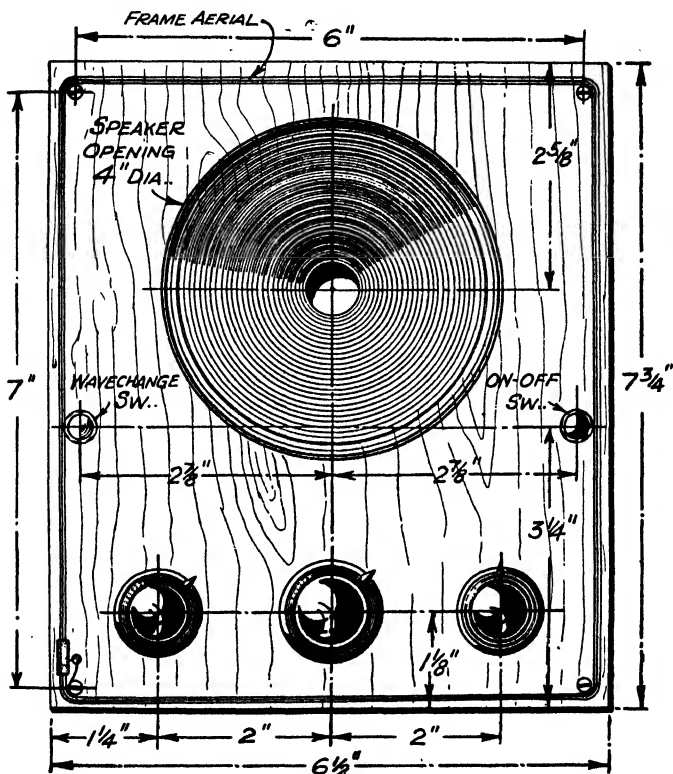

FIG. 57.—Dimensions for drilling Panel and making frame-aerial winding for Circuit No. 22.

scheme may suggest itself to the handyman—for instance, short ebonite rods may be tapped and bolted to the panel, or lengths of ordinary B.A. studding may be cut off and held in position with lock-nuts at front and rear. Whatever course is adopted, the length should be approximately the

same as the control spindles of the condensers. If metal is employed for these supports, some insulating material should be placed over them. Ordinary insulating tape may be wrapped round two or three times, or lengths of thin glass-

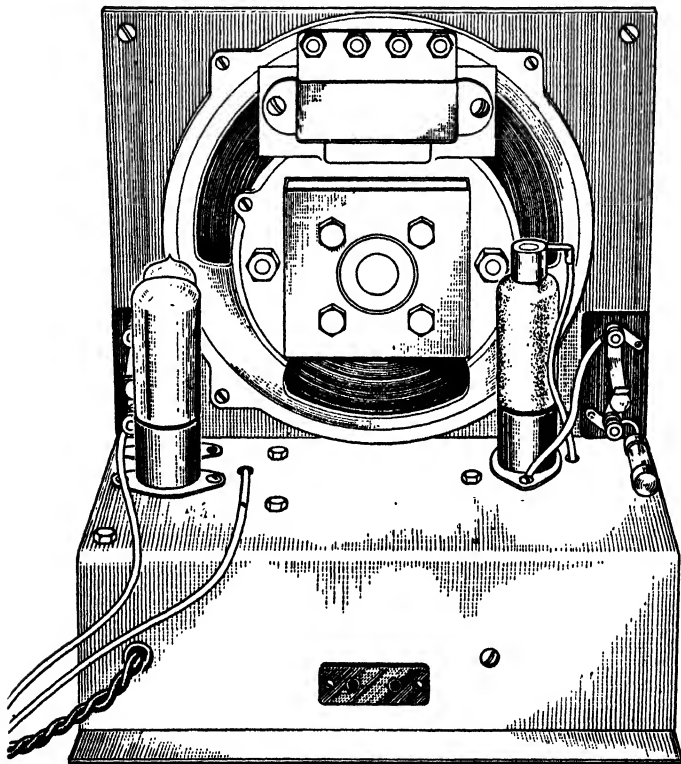

FIG. 58.—The Chassis of Circuit No. 22.

tubing may be slipped over and held in position with sealing wax—Chatterton's Compound or some similar medium. The panel is attached to the front of the metal chassis by means of the frame-aerial supporting bolts, and also by the fixing nuts on the three condensers. The frame aerial

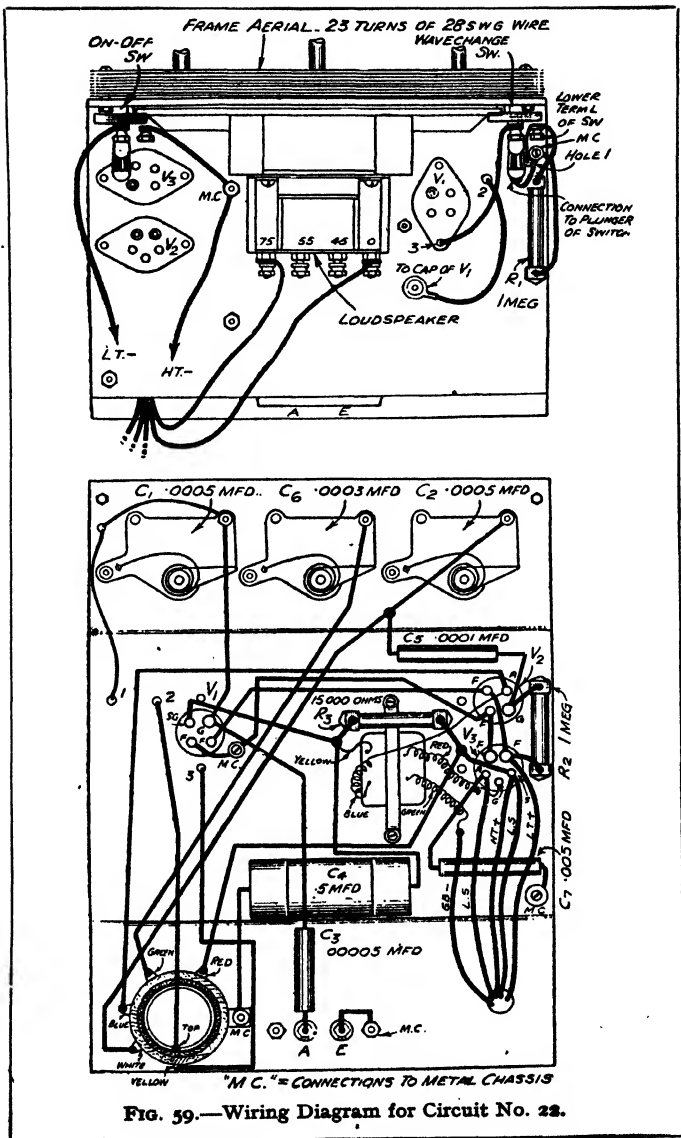

FIG. 59.—Wiring Diagram for Circuit No. 28.

winding is commenced from the switch position, one end of the covered wire being passed through the hole and anchored to the lower terminal on the on-off switch. It is then taken down round the lower support, across to the opposite side and so on, round the four supports until twenty-three turns have been put on. The end of the winding, when the wire comes down to the hole where the beginning was taken through, should be taken into the inside of the chassis and attached to the fixed plate terminal on the first tuning condenser.

Great care must be taken to make the correct connections to the coil, and it will be noted that the wave-change switch is of the two-point type although it is employed in this case as a three-point switch. For this purpose a flexible lead is soldered to the metal plunger of the switch and this is joined to earth. One terminal on the switch is then joined to the yellow lead on the tuning coil whilst the other switch terminal is joined to the junction of the frame aerial winding and the resistance R_1 .

It will be noted that the frame aerial is wound only for the medium waves, and thus for long waves the resistance in series is used as a loading component. This has proved quite satisfactory in use and saves the constructor a considerable amount of difficulty in winding the aerial. Obviously, to obtain maximum results under these conditions, a throw-out aerial is desirable, and it will be noted in the diagrams that a fixed condenser, C_3 , has been included between the frame-aerial winding and the aerial socket. The value given in the diagram and list of parts is $\cdot 00005$ mfd, but if any difficulty is experienced in obtaining a tubular condenser of this type, the ordinary mica type of condenser may be used, or some other value tried. In some parts of the country it may be found that best results will be obtained with some alternative value, and up to $\cdot 0002$ mfd. may be tried. Similarly, the earth connection may be connected to some earthed body in order to obtain greater signal strength, although again, much will depend upon the location where the set is being used.

LIST OF COMPONENTS FOR CIRCUIT NO. 22

1 midget coil.

60 ft. 28 S.W.G. D.C.C. wire.

2 $\cdot 0005$ -mfd. bakelite tuning condensers (C.1 and C.2).

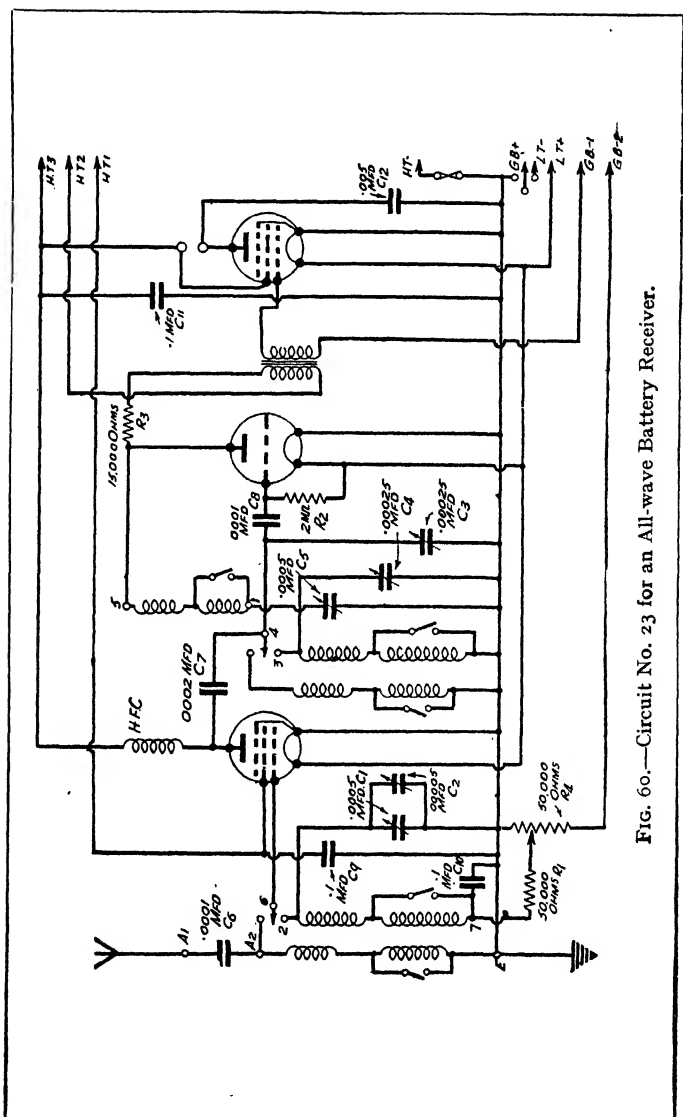

Fig. 60.—Circuit No. 23 for an All-wave Battery Receiver.

- 1 .0003-mfd. bakelite reaction condenser (C6).
- 4 fixed condensers (tubular type): .00005-mfd. (C3), .0001-mfd. (C5), .0005-mfd. (C7), .5-mfd. (C4).
- 3 fixed resistors 1-watt type, 2 1-megohm (R1 and R2), 1 15,000-ohms (R3).
- 1 L.F. transformer.
- 1 terminal socket strip.
- 3 valveholders, midget type: 2 4-pin, 1 5-pin.
- 2 switches type S.22.
- 3 midget valves, S.G. detector and pentode.
- 1 metal chassis, 6½ in. x 4½ in. x 2½ in., and panel 6½ in. x 7½ in.
- 1 pair of headphones.
- 1 midget loud-speaker type 37M.
- 1 H.T. battery (72-volts).
- 1 3 A.H. accumulator, type PRP3.
- 1 cabinet.

Circuit No. 23.—Figs. 60 to 62 show a circuit for an all-wave receiver employing three valves. It will be seen that although a straight three arrangement is employed the short-wave and normal broadcast units are separated, a complete changeover being effected by the self-contained switch. This arrangement is preferable to the method where all coils are connected in series. A further point is that in the detector grid circuit a small capacity tuning condenser is employed on short-waves and the standard capacity on the broadcast wavebands. This is carried out by using a 3-gang condenser in which two of the sections have a maximum capacity of .00025 mfd. and one of .0005 mfd. The two smaller sections are wired to contacts on the switch element so that on the broadcast bands the two sections are in parallel, but on short-waves only one section is in use and this is connected in parallel in the usual way with the short-wave coil. In the aerial circuit, where the tuning is not critical on short waves, the addition of a .00005 mfd. trimmer attached to the tuning dial enables the tuning to be satisfactorily adjusted, and the inductances of the coils are arranged so that the correct waveband is covered with the .0005 mfd. condenser.

The first valve is a variable- μ H.F. pentode, adjustment of bias by means of a panel-controlled potentiometer providing a control of volume or signal strength. The parallel-tuned anode coupling is employed between the first valve and the detector, and this valve is transformer coupled to the output pentode. Instead of using an H.F. choke for reaction purposes a resistor is employed, and this gives a much smoother control of reaction on the short-waves, and

the value which has been selected ensures good reaction control on the remaining wavebands. It will be noted also

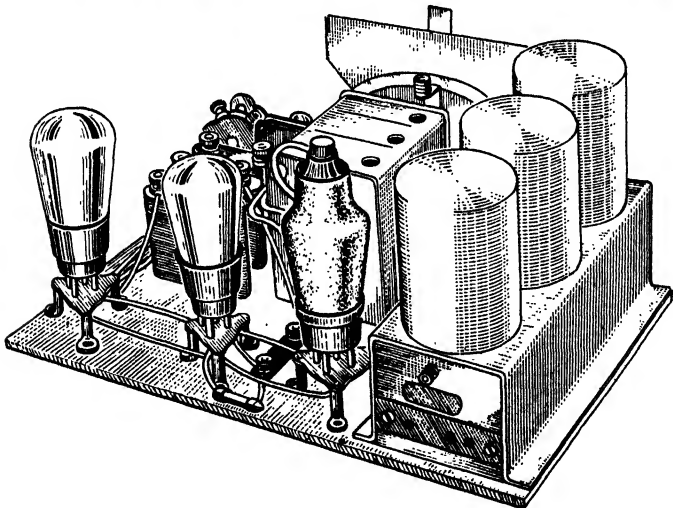
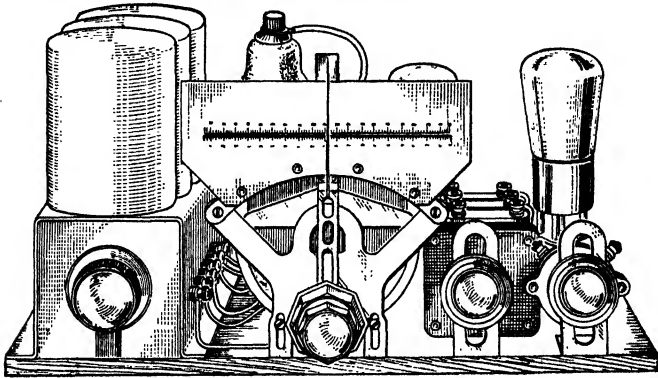

FIGS: 61 AND 62.—Views of the finished All-wave Battery Receiver (Circuit No. 23).

that the reaction winding is adjusted for the separate wave ranges, the switch for this being ganged with the remaining wavechange switch elements. The L.F. transformer is

direct fed, and the H.T. supply for the detector valve, as well as for the screen of the H.F. valve, is arranged with a separate lead so that the optimum working conditions may be found under all circumstances.

Attach lengths of wire to terminals 4, 5, 6, and 7 on the coil unit and place the latter in its position, cutting off the wires so that they will just reach to the respective connecting points as shown on the blueprint. Then cut off lengths of insulating sleeving and slip over each of these wires. Push the end of the short wire on terminal 6 through the grid socket on V.1 and screw down the coil unit, afterwards attaching the wires from terminals 4, 5, and 7 to their respective points. Replace the terminal on the grid condenser when the lead from terminal 4 on the coil unit is in position, and then attach one end of the anode resistance R.3 (15000 ohms), to the detector anode socket, locking this together with the wire from terminal 5 on the coil unit.

LIST OF COMPONENTS FOR CIRCUIT NO. 23

- 1 all-wave coil unit.
- 1 3-gang condenser (.00025 + .00025 + .0005 mfd.) (C₁, C₃, C₄).
- 1 slow-motion drive including .00005-mfd. trimmer (C₂).
- 1 .0005 mfd. reaction condenser (C₅).
- 6 fixed resistances; 3 1 mfd., 1 .005 mfd., 1 .0001 mfd., 1 .0002 mfd.
- 3 half-watt resistors: 1 15,000-ohms, 1 50,000-ohms, 1 2-megohms.
- 1 volume control potentiometer with switch, 50,000-ohms.
- 1 all-wave H.F. choke.
- 1 L.F. transformer.
- 2 component mounting brackets.
- 3 baseboard mounting short-wave valveholders, 2 4-pin and 1 5-pin.
- 7 bowstring wander plugs: H.T.-, H.T.1, H.T.2, H.T.3, G.B. + G.B.-1, G.B.-2.
- 2 spades L.T. + and L.T.-.
- 3 valves.
- 1 speaker.
- 1 H.T. battery.
- 1 G.B. battery.
- 1 2-volt L.T. accumulator.
- 1 cabinet.

Circuit No. 24.—This is an ideal three-valver for the very beginner and employs a baseboard so that the wiring presents no difficulty. Fig. 63 shows the circuit, which covers four separate wave-bands, and the circuit is one which has been well tried. The main features are to be found in the initial stage which is a simple detector in the grid circuit of which a pair of coils are fitted. These consist

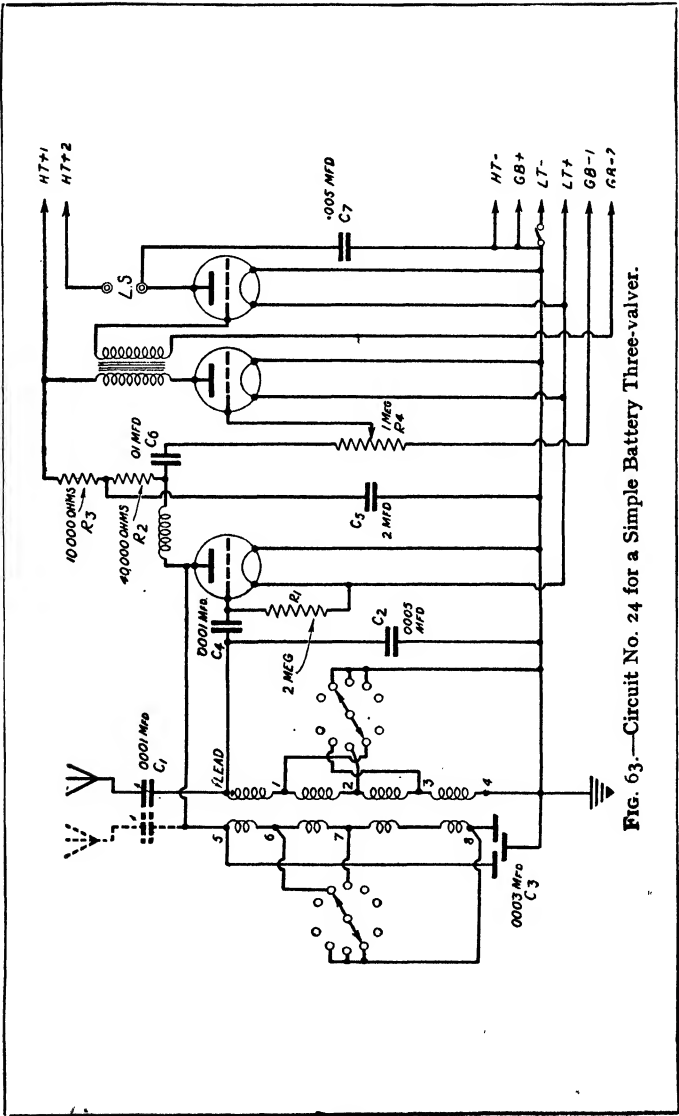

Fig. 63.—Circuit No. 24 for a Simple Battery Three-valver.

of the broadcast and short-wave coils, arranged on separate formers and in separate cans, the connections being brought out to the soldering tags on a special insulating base. They are designed for chassis construction and so, as will be seen from Fig. 64, I have mounted the unit on its side by the aid of a component mounting bracket.

The aerial is normally connected to a lead on the coil unit through a series aerial condenser, whilst a reaction winding on each coil section is employed in the usual manner

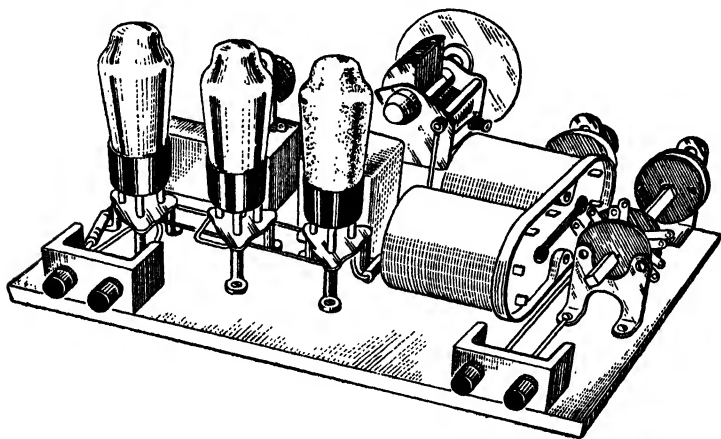
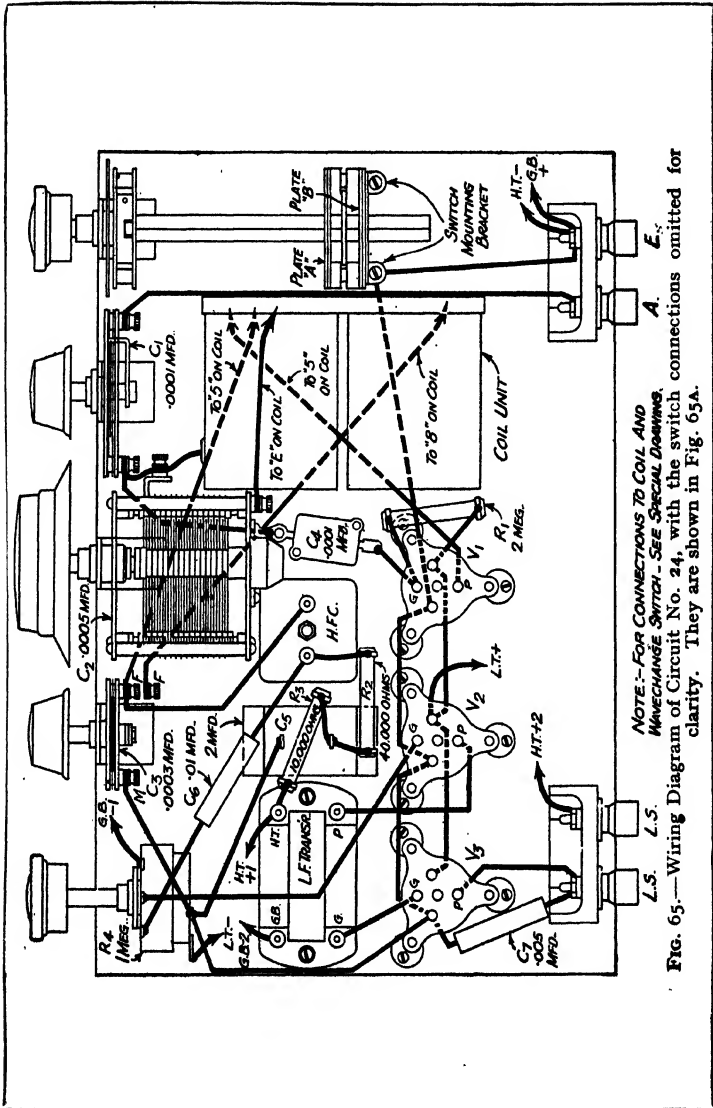

FIG. 64.—Circuit No. 24 as built.

through a differential reaction condenser. However, an alternative scheme is made available and the aerial lead may be transferred to point No. 5 on the coil, thus providing a combined aerial coupling coil and reaction circuit, and in some cases it may be found that this offers better results. In the anode circuit of the detector valve the usual H.F. choke is connected, but connection between this stage and the first L.F. stage is by means of resistance-capacity components, and this enables the grid leak to be used in the form of a potentiometer so that the input to this valve may be controlled. The result is that a most effective volume control is formed for use when headphones are



NOTE:—FOR CONNECTIONS TO COIL AND WAVELENGTH SWITCH—SEE SPECIAL DRAWINGS.

Fig. 65.—Wiring Diagram of Circuit No. 24, with the switch connections omitted for clarity. They are shown in Fig. 65A.

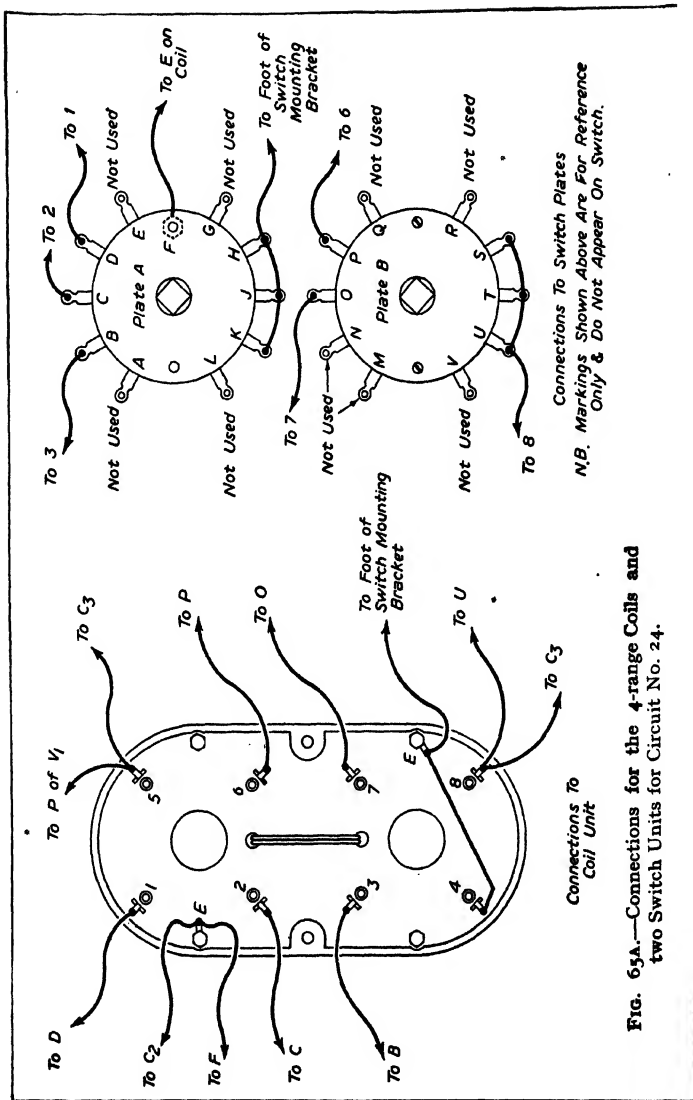

Connections To Switch Plates
N.B. Markings Shown Above Are For Reference Only & Do Not Appear On Switch.

Connections To
 Coil Unit

FIG. 65A.—Connections for the 4-range Coils and two Switch Units for Circuit No. 24.

employed for searching, and this avoids the sudden bursts of volume which are liable to be met when no such control is fitted. Ordinary transformer coupling is employed between the L.F. and output stage, and for the latter a Power valve is used in preference to a pentode, both in the interests of economy and simplicity.

All the other usual circuit refinements which may be fitted to this type of receiver are to be found.

The four ranges covered by the receiver are approximately from 15 to 35 metres, 30 to 85 metres, 200 to 550 metres, and 1000 to 2000 metres.

LIST OF COMPONENTS FOR CIRCUIT NO. 24

- 1 4-range coil, No. C56.
- 1 driver-locator unit No. S150.
- 1 5-way contact unit No. S153.
- 1 .0005 mfd. condenser No. 2SM.
- 1 .0003 mfd. differential reaction condenser.
- 1 .0001 mfd. Compax condenser (C1).
- 4 fixed resistors: .0001 mfd. (C4), .005 mfd. (C7), .01 mfd. (C6), 2 mfd. (C5).
- 3 fixed resistors: 2 megohm (R1), 40,000 (R2), 10,000 (R3) (1-watt type).
- 1 potentiometer, 1 megohm with 2-point switch (R4).
- 1 L.F. transformer 3/1 No. LT135.
- 1 all-wave choke No. A.W.C1.
- 3 4-pin S.W. type baseboard mounting valveholders.
- 2 terminal blocks with A.E. and L.S. terminals.
- 6 plugs: H.T.-, H.T.1, H.T.2, G.B.+, G.B.-1, G.B.-2.
- 2 spades L.T.-, L.T.+.
- 1 baseboard 12 in. x 8 in.
- 6 component brackets.
- 3 valves: 1 detector, 1 L.F. and 1 power.
- 1 speaker.
- 1 H.T. battery 120-volts.
- 1 G.B. battery 9-volts.
- 1 L.T. accumulator.

Circuit No. 25.—This circuit (Fig. 66) employs a Quiescent Push-pull output stage, and although this has now been superseded by the Class B arrangement, it is included in this book for the use of those readers who may possess one or more pentode valves, and prefer the slight lack of efficiency to the additional expense of purchasing Class B components. The tuning is carried out by means of band-pass circuits, and the condenser is of the ordinary two-gang type, having a separate concentric trimming knob. The L.F. transformer

should be of the special high ratio Q.P.P. type, and the grid bias should be carefully adjusted. This gives a very large signal output, and the range of the detector valve (which is of the S.G. type) is quite considerable. It is worth while building this receiver in one of the Consolette types of cabinet, with the speaker housed in the upper portion.

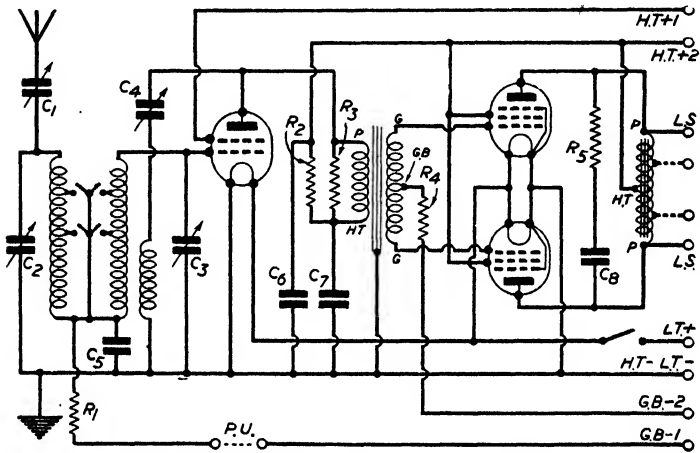

FIG. 66.—The theoretical Circuit No. 25 of the Q.P.P. Three-valve.

LIST OF COMPONENTS FOR CIRCUIT NO. 25

- | | |
|--|--|
| 1 2-gang .0005-mfd. variable condenser with escutcheon (C ₂ , C ₃). | 1 4-pin valve-holder |
| 1 .0003-mfd. fixed condensers (C ₁). | 1 coil unit. |
| 1 .01-mfd. fixed condenser (C ₅). | 1 On-Off switch. |
| 1 1-mfd. condenser (C ₇). | 6 terminals, marked E, A, L.S., L.S., Pick-up, Pick-up. |
| 1 2-mfd. condenser (C ₆). | 6 wander plugs, marked G.B. +, G.B. 1, G.B. 2, H.T., H.T. +1, H.T. +2. |
| 1 .02-mfd. condenser (C ₈). | 1 7-way battery cord. |
| 1 .0005-mfd. reaction condenser (C ₄). | 2 L.T. spade terminals. |
| 1 1000-ohm 1-watt resistance (R ₂). | 1 grid-bias clip. |
| 1 20,000-ohm 1-watt resistance (R ₅). | 2 coils insulated wire. |
| 1 80,000-ohm 1-watt resistance (R ₃). | 2 valves Pen. 220A. |
| 1 50,000-ohm 1-watt resistance (R ₁). | 1 valve 215 S.G. |
| 1 100,000-ohm 1-watt resistance (R ₄). | 1 P.M. moving coil speaker. |
| 1 Q.P.P. transformer. | 1 panel, 14 in. x 8 in. |
| 1 Q.P.P. output choke. | 1 plywood baseboard, 19 in. x 7 in. |
| 2 5-pin valve-holders. | |

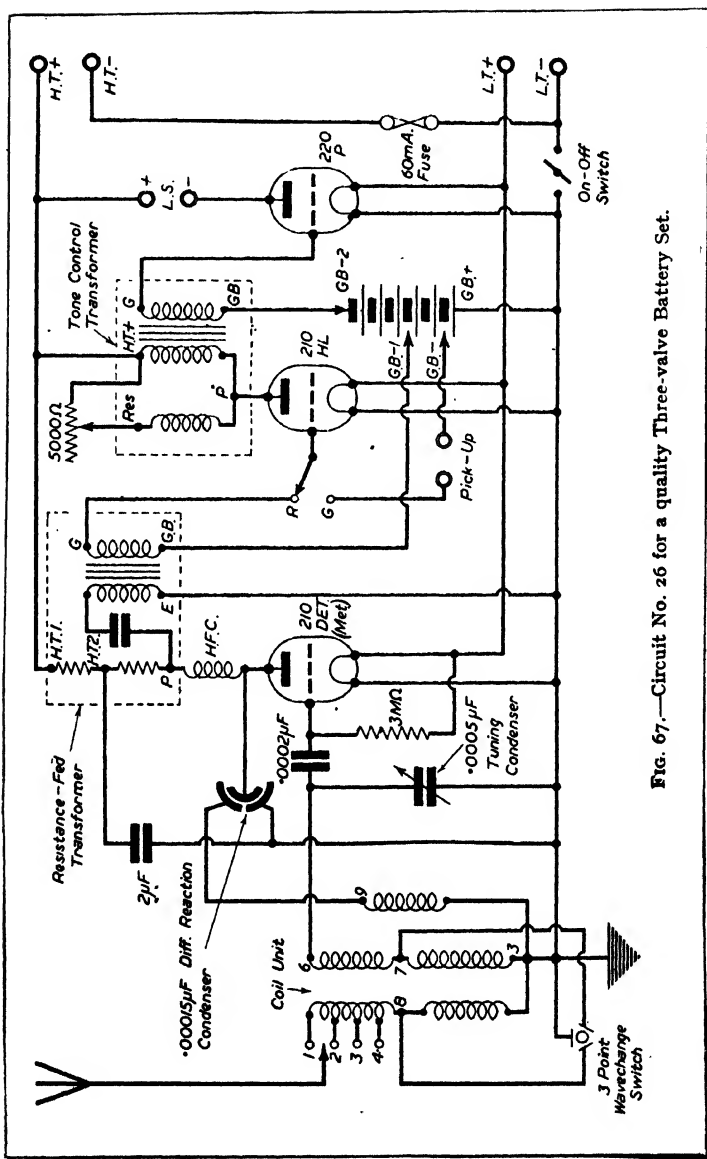

FIG. 67.—Circuit No. 26 for a quality Three-valve Battery Set.

Circuit No. 26.—This (Fig. 67) is an efficient receiver of simple construction, capable of giving high quality results from a number of stations. Tone control is incorporated, and although no H.F. stages are fitted, the range of the receiver is quite considerable. Switching for gramophone pick-up is incorporated, and therefore the receiver lends itself to the construction of a neat radio-gramophone. The receiver is very economical to run, the total H.T. consumption being only approximately 7 milliamps. The output varies between 110 to 140 milliwatts. The wiring is very straightforward, and no difficulty should be experienced in the construction.

LIST OF COMPONENTS FOR CIRCUIT NO. 26

- 1 plywood panel, 14 in. × 8 in.
 - 1 standard .0005-mfd. condenser.
 - 1 micro-dial.
 - 1 .00015-mfd. differential condenser.
 - 1 type "T.D." coil.
 - 1 3-point wavechange switch.
 - 1 On-Off battery switch.
 - 1 radio-gram switch.
 - 1 5000-ohm potentiometer.
 - 3 valve-holders.
 - 1 .0002-mfd. fixed condenser.
 - 1 3-megohm grid leak.
 - 1 grid-leak holder.
 - 1 standard H.F. choke.
 - 1 Transfeeda.
 - 1 2-mfd. condenser.
 - 1 L.F. transformer.
- 1 baseboard fuse-holder with 60 mA. fuse.
 - 10 terminals—1 each marked A, E, L.T.+, L.T.-, H.T.-, H.T.+, L.S.-, L.S.+, and 2 marked Pick-up.
 - 6 wander plugs—marked G.B.+, G.B.-, G.B.-1, G.B.-2, H.T.+, H.T.-.
 - 1 strip ebonite, 14 in. × 1½ in.
 - 1 G.B. battery clip.
 - 1 coil insulated connecting wire.
 - 1 short length flex.
 - 1 5-ply baseboard, 14 in. × 8 in.
 - 2 pieces hardwood, 8 in. × 3½ in. × ½ in.
 - 1 piece 3-ply, 14 in. × 2 in.

Circuit No. 27.—This is an excellent battery operated receiver with ample range and output equivalent to a mains set and reasonable selectivity. The quality is excellent. It will be seen that the output is in push-pull which is desirable when a large output is required, and particularly when quality reproduction is of prime importance. Fig. 68 shows that the arrangement is on straightforward lines. Air-core coils of sound design and of a type providing reasonable selectivity are used both in the aerial and in the intervalve circuit. Each coil is of the H.F. transformer type of which the primary is untuned; and both are fitted with built-in wavechange switching so that the number of external connections is reduced to a minimum. The first valve is a variable- μ H.F. pentode, and this provides a really large measure of amplification besides forming an ideal distortionless volume control. The detector circuit follows on conventional lines, and includes a reaction condenser that gives a smooth control of volume and also enables selectivity to be increased when desired. It is also amply decoupled, with a result that there is no danger of instability or L.F. oscillation, whether the set is used with an eliminator, or with a H.T. battery that is past its prime.

It is the output stage, however, that merits most attention, since this includes two modern valves in a modern push-pull circuit. The degree of amplification given by a push-pull stage is more than double that of a single valve, the output actually being something like two and a half times that of a single L.F. valve. Push-pull has the further advantage that it is practically distortionless, due to the fact that the two valves tend to cancel out any distortion that might otherwise exist.

In designing the push-pull output stage care has been taken to avoid any possibility of instability, and it is for this reason that stopper resistances have been included in the grid leads to the two valves. Still further to ensure perfect stability, the two halves of the secondary winding of the input push-pull transformer are shunted by means of small fixed condensers. Theoretically, two valves used together in a push-pull circuit should be perfectly matched, which means that they should be chosen from the makers' stock with great care. There is generally an extra charge made for accurately-matched pairs of valves, however, and besides this, they cannot be obtained from the local dealer.

LIST OF COMPONENTS FOR CIRCUIT NO. 27

- 1 metaplex chassis, 10 in. x 8 in. with 3 in. runners.
 - 1 2-gang condenser, Baby type with dial.
 - 1 2-coil assembly, type T.D.S.
 - 1 reaction condenser .0003 mfd. (C₃).
 - 1 pre-set condenser, .0003 mfd. (C₄).
 - 4 fixed condensers, 2 .5-tubular (C₇ and C₁₀), 2 .1-tubular type 250 (C₅ and C₆).
 - 4 .0002-fixed condensers, type "M" (C₈, C₉, C₁₁, C₁₂).
 - 1 50,000-ohm. potentiometer (R₁).
 - 4-ohm. resistances, 1 meg. (R₂), 30,000 (R₃), 2 10,000 ohms. (R₄ and R₅).
 - 1 input push-pull transformer, type DP36.
 - 1 H.F. choke, type H.F.8.
 - 3 potentiometer brackets.
 - 2 terminal strips, A.E. and L.S..P.U.
 - 6 plugs, G.B.-1, G.B.-2, G.B.+ , H.T.- , H.T.+1, H.T.+2.
 - 2 spade terminals, L.T.+ and L.T.-.
 - 4 valves: 1 variable mu H.F. pentode, 1 detector valve, and 2 economy triodes.
- Loudspeaker.
- 1 on-off switch (3-point).
 - 2 5-pin valve-holders.
 - 2 4-pin valve-holders.
 - 1 cabinet.
 - 1 120-volt H.T. battery.
 - 1 9-volt G.B. battery.
 - 1 2-volt accumulator.

Circuit No. 28.—Fig. 69 is a simple four-valve arrangement, consisting of a screen-grid valve, detector, and two transformer-coupled low-frequency stages. The H.F. valve is coupled by what is known as the parallel-fed method, a H.F. choke being included in the anode circuit of the screen-grid valve. This choke must be of the special kind designed for use with this type of valve. There will be loss of amplification if the usual type of choke is included here. For the L.F. transformers, a low-ratio one should be used for the first stage, and a high-ratio for the second. The valves required, in their order, are: screen-grid, general-purpose or detector, L.F., and power. This last valve should be of the type which will handle a fairly powerful signal if distortion is to be avoided. Ordinary plug-in coils are used, a No. 60X for the aerial circuit, No. 60 for L₂, and No. 50 for L₃. These are, of course, for the normal broadcasting band. For the long waves, they will be No. 250, 250, and 100, respectively. The H.T. values should be 80 volts for +1, 100 to 120 volts for +2, and the maximum taken by the particular valve purchased for +3. In the case of battery valves this will be 150 volts.

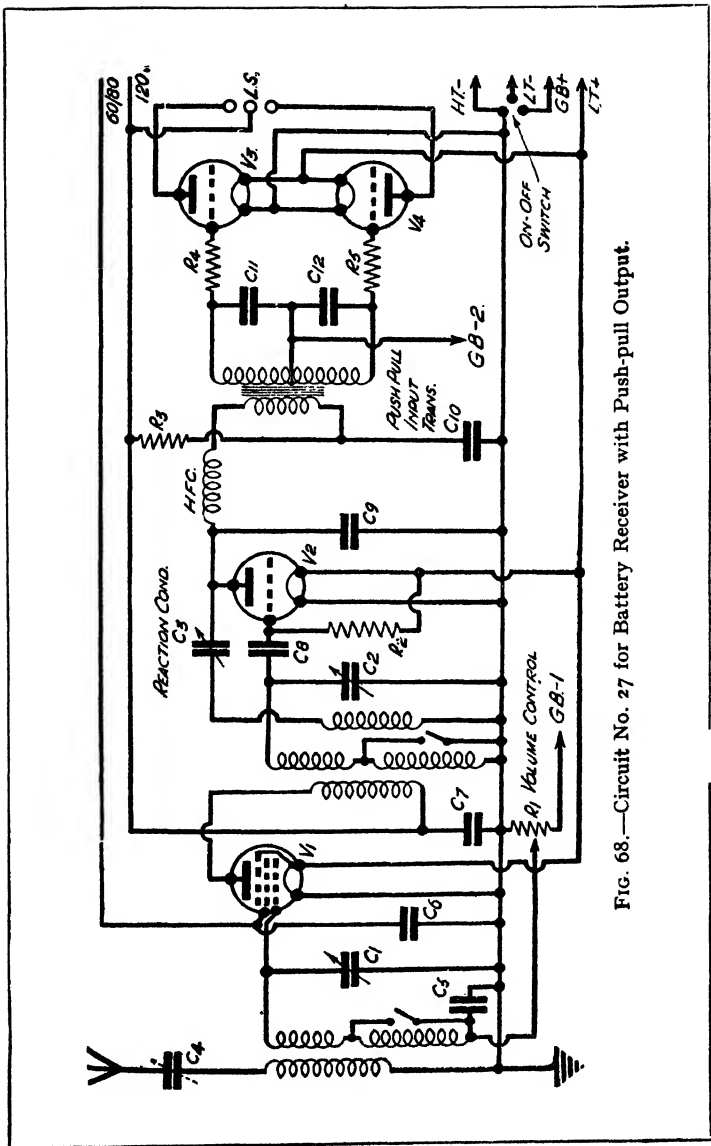

Fig. 68.—Circuit No. 27 for Battery Receiver with Push-pull Output.

LIST OF COMPONENTS FOR CIRCUIT NO. 28

- 2 ·0005-mfd. variable condensers (C₁ and C₂).
- 1 ·0003-mfd. variable condenser (C₃).
- 1 ·0002-mfd. fixed condenser (C₅).
- 1 ·001-mfd. fixed condenser (C₄).
- 1 H.F. choke—screen-grid type.
- 1 H.F. choke—ordinary type.
- 1 low-ratio L.F. transformer.
- 1 high-ratio L.F. transformer.
- 1 2-megohm grid leak and holder (R₁).
- 3 baseboard mounting coil-holders.
- Coils as mentioned in above notes.
- 1 on-and-off switch (S₁).
- Terminals, connecting wire, and screws.

Circuit No. 29.—This circuit (Fig. 70), is on the same lines as No. 20 except that the H.F. valve is coupled by the tuned-anode method, which gives greater signal-strength, but requires a little more care in construction. A special type of commercial coil will be required, and this should be wound in what is known as the astatic manner. In addition, a vertical screen of copper or aluminium must be affixed to the baseboard, and a hole in the screen should allow the valve to be mounted with the screening grid in the same plane as the screen. On one side of the screen all the grid circuit components are mounted, whilst on the other the anode components are fixed. The screen is shown in the circuit diagram. The aerial circuit coils L₁ and L₂ may be ordinary plug-in coils or a commercial six-pin aerial transformer. No H.F. choke is required in the anode circuit of the detector valve, as the anode resistance acts as an efficient H.F. stopper.

LIST OF COMPONENTS FOR CIRCUIT NO. 29

- 2 ·0005-mfd. variable condensers (C₁ and C₂).
- 1 ·0003-mfd. variable condenser (C₃).
- 1 ·001-mfd. fixed condenser (C₄).
- 1 ·0002-mfd. fixed condenser (C₅).
- 2 2-megohm grid leaks and holders (R₁ and R₃).
- 1 100,000-ohm anode resistance and holder (R₂).
- 1 medium-ratio L.F. transformer.
- 1 astatic tuned anode unit with reaction.
- 1 aerial transformer or coils and holders.
- 4 valve-holders (one of the horizontal screen-grid type).
- 1 on-and-off switch (S₁).
- Aluminium screen with hole for valve.
- Terminals, connecting wire, and screws.

Circuit No. 30.—Fig. 71 shows a circuit for a four-valve receiver battery operated covering three wave-bands but having two tuned circuits.

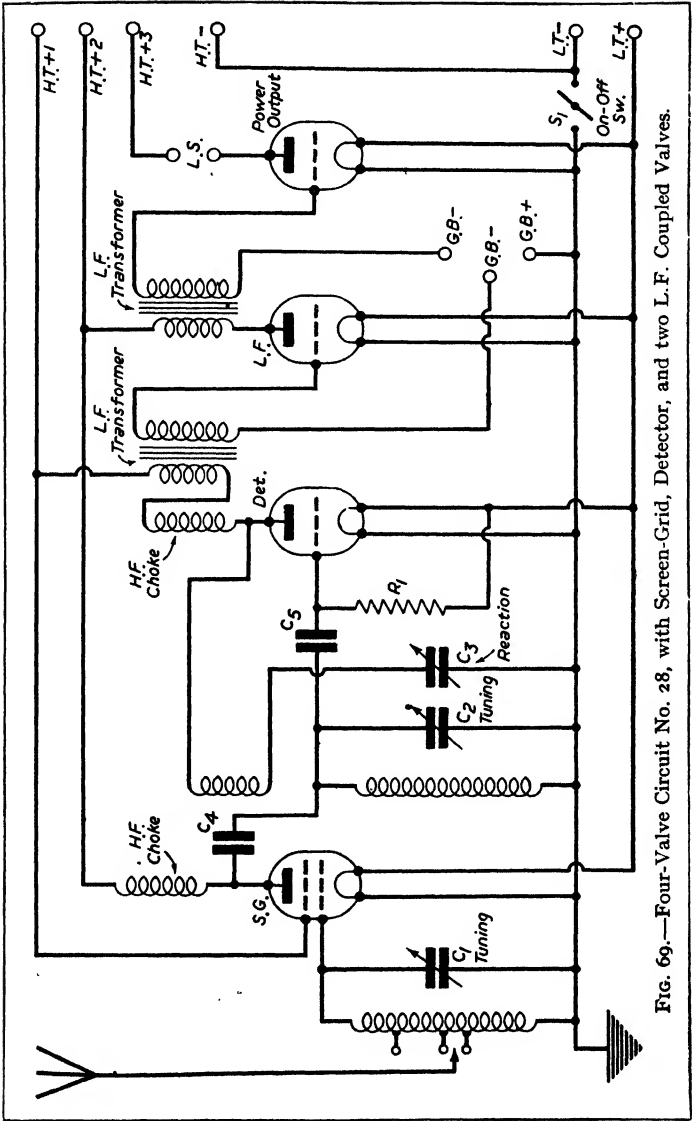

Fig. 69.—Four-Valve Circuit No. 28, with Screen-Grid, Detector, and two L.F. Coupled Valves.

An examination of the circuit reveals that the four valves employed include an H.F. pentode as H.F. amplifier, a triode as detector, and triodes as L.F. amplifier, and output valves respectively. There are two tuned circuits with H.F. transformer coupling between H.F. valves and the detector to ensure a high degree of selectivity. The receiver covers three wave-bands—19 to 48 metres, 200 to 550 metres, and 900 to 2200 metres. Two tuned circuits on the three-wave-bands are employed as stated, whilst resistance capacity coupling between the detector and L.F. valve is employed to ensure high quality. You will observe that the detector anode circuit is adequately decoupled to avoid L.F. instability, whilst a L.F. transformer couples the L.F. and output valves. The output feeds a permanent magnet speaker which may be instantaneously and accurately matched to the impedance of the output valve. The coil unit has the wave-change switch incorporated. If a chassis is obtained with the holes ready drilled for the valveholders work is much facilitated. I recommend a metallised wooden chassis.

There is only one small point which requires to be mentioned when dealing with the construction of this receiver, and that is concerning the holding-down screws for the condenser, coils, transformer, etc. The metal surface of the chassis is of fairly thick aluminium, and unless a clearance hole is first drilled to accommodate the plain shank of the screws it will be found that the screw head will be twisted off. Therefore, mark out the positions of the screw carefully by pricking through the lugs on the various parts, and then with an $\frac{1}{8}$ -inch drill cut through the aluminium only. As soon as the wood appears, cease drilling and an ordinary awl may then be used to start the screws into the wood.

Before mounting the coils, transformer, variable condenser, and component brackets some of the wiring can be completed and therefore the most comfortable plan in building this set is to mount the valveholders, fuse-holder and terminal strips in that order first, when the chassis may be inverted and will rest comfortably on the work-bench whilst the various sub-chassis components are wired into position. Where leads pass through the chassis they may be cut off to sufficient length and led through the relative hole, and afterwards cut off to length. Another plan, and one which is favoured by many constructors, is to mount every component first and then carry out the wiring. In this case, to

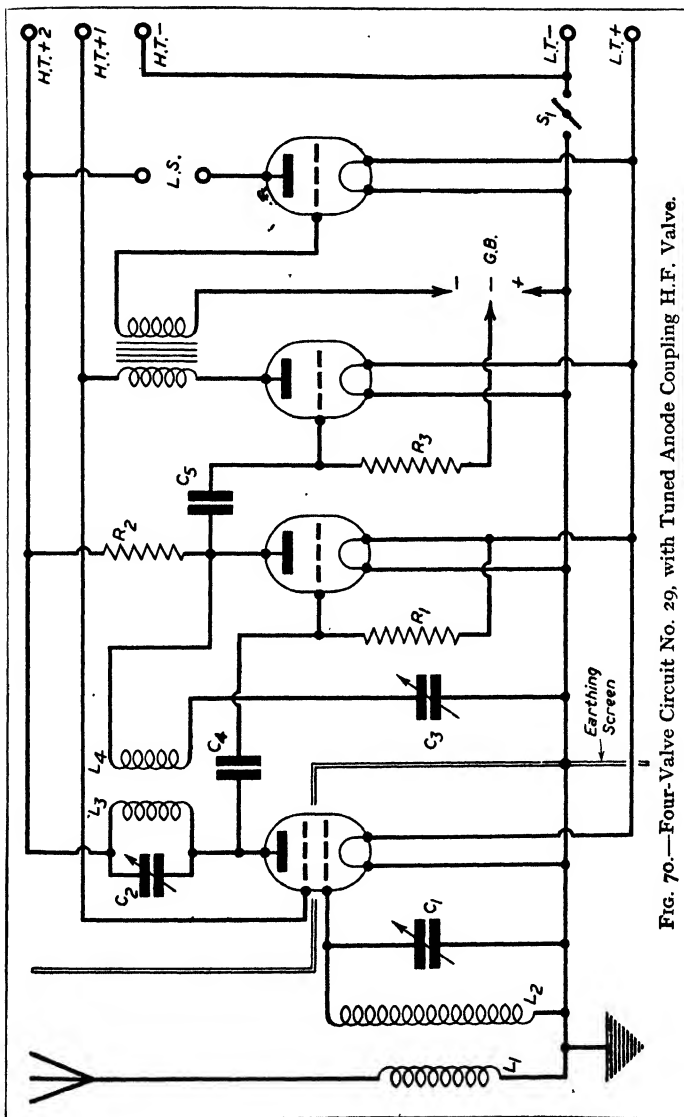

Fig. 70.—Four-Valve Circuit No. 29, with Tuned Anode Coupling H.F. Valve.

enable the chassis easily to be inverted from time to time during wiring, two lengths of wood should be screwed to the side runners, of sufficient length to clear the condenser, and the set will rest on these when inverted and thus stand firm.

The wiring should be carried out with a fairly heavy gauge wire—say 18 or 20 bare-tinned copper. Make certain that all leads are fairly rigid and stretch them from point to point to avoid difficulties on the short-wave band which might be introduced by wires which move when subjected to vibration. Where the leads pass through the chassis it may be advisable to take some precaution to avoid short-circuits and there are two methods of doing this. Firstly, lengths of insulated sleeving may be slipped over the wires of such a diameter that they wedge into the hole and thus prevent the wire from touching the edge of the metal. A simpler plan is to remove the metal round the hole, either with a countersink bit, or by scraping round with a pen-knife. The insulated sleeving is the most business-like method, and lends a finished appearance to the set. The points marked M.C. on the blue-print indicate that the wires at that point are in contact with the metal chassis. The method of doing this is to take a long bolt and two fairly large washers which may then be used to hold in place the wires referred to. On the coil units the two M.C. points will be served by the screws used to hold down the coil screens. Remember in all of these cases, that the ends of the wires should be turned in a clock-wise direction so that when the screws are tightened up the wires will not be pushed out. If the ends are turned in an anti-clockwise direction, as the screws are tightened the ends of the wires will be pushed out from between the washers or screw-head.

In the case of the ganged condenser it is important to note that the two leads which come up through holes 4 and 6 are joined to the tags in contact with the *fixed* sets of plates. There are two contacts on the underside of the condenser chassis for this purpose, and they are in the same electrical relationship as the tags on top of the condenser to which the leads from terminals S on the two coil units are joined. By making use of the lower tags you avoid the necessity of running long leads up from the chassis to the top of the condenser. It is also necessary, if this is your first attempt at receiver construction, to be on your guard when wiring the five leads to the combined volume control and

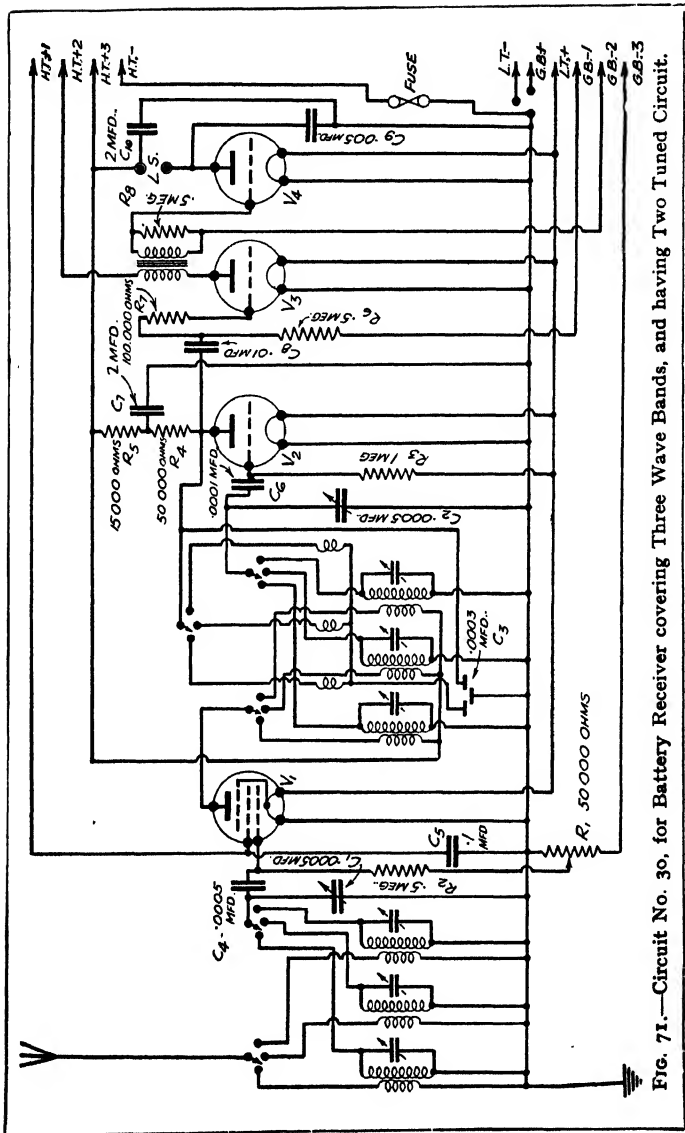

Fig. 71.—Circuit No. 30, for Battery Receiver covering Three Wave Bands, and having Two Tuned Circuit.

on-off switch. Three connections are made to the top and three to a lower part, and the leads from holes 7 and 8 and from the chassis (M.C.) are joined to the switch contacts. These appear on the raised ebonite portion attached to the centre of the component. Round the edge of the larger part of the component are three further lugs and these are joined to the volume control, and to them leads from holes 9 and 10 are joined.

Remember that the trimmers on the ganged condenser are not used with this particular coil assembly, and thus they should be opened to their widest position. Alternatively, you can unscrew them entirely, and open them out so that they have no effect at all on the inter-circuit wiring. By doing this you will make quite sure that the minimum wavelength on the short waveband will be covered. The trimmers which have to be adjusted for the medium-wave band are in the coil unit and are identified by the number "2." Use a thin screwdriver or a pointed or sharpened slip of wood for adjusting this screw so that no undue capacity effects are introduced. Turn each of the trimmers marked "2" until maximum volume is obtained at the dial setting given for your local station. Of course, it will be assumed that when mounting the dial you have first set the moving vanes of the condenser to either the minimum or maximum setting and have placed the point on the dial to a similar position. If this is not done, of course, the pointer will not travel completely across the scale and the station indications will be all out of position. As the signal strength of a local station is increased with the trimming adjustments, the volume control should be turned back so that a weak signal is maintained as this enables the adjustments to be more easily made. It is very difficult to notice an improvement in strength if the station is blaring out on the loud-speaker, but if turned so that only a very weak signal is heard, the slightest improvement or loss of volume will be heard.

When the medium waves have been satisfactorily trimmed it should be possible to turn from one end of the scale to the other and pick up stations at various places on the dial, the stations heard in your particular locality depending upon local conditions. The direction of your aerial, its height above ground, any screening which might be introduced by surrounding buildings, trees, hills, etc., will all affect results and therefore it is not

possible to say just what you will hear. It should be possible, however, in most parts of the country to pick up quite a number of stations, both English and continental, at good volume. The long-wave band is trimmed by adjusting trimmers numbered "3" and the same procedure is carried out as has been mentioned for the medium-wave band.

For the short-waves the process is slightly more difficult and all adjustments must be made very carefully indeed. This time the trimmers used are numbered "1" and the location of a station upon which to make the adjustments may be found rather difficult if you have never used a short-wave receiver before. In spite of the reduction gearing on the tuning control, the very slowest adjustments should be made, and you will probably find that the reaction condenser may now be used as an aid to trimming. Advance the reaction condenser until the receiver is brought to the verge of oscillation. This will be indicated by a rushing sound in the loud-speaker, and if carried too far, a whistle will be heard. When a station is tuned, a rising whistle will be heard, and this may fall as the condenser is turned still further. Slacken off the reaction control until the whistle ceases and re-adjust the tuning condenser. Then adjust the trimmers and note carefully when any improvement is made in signal strength, without touching the reaction condenser. You will probably find it necessary to trim on stations at both ends of the scale on the short-waves and a slight compromise may have to be effected so that the best results are obtained throughout the scale. The reaction condenser will, of course, slightly modify the effects of the trimmers and thus the trimming on short-waves will have to be carried out carefully in order to obtain maximum results. When once adjusted, however, no further difficulties should arise, and it should then be possible to turn through the scale on either of the three wavebands, and pick up stations at various parts of the dial, augmenting signal strength, where required, by means of the reaction condenser.

LIST OF COMPONENTS FOR CIRCUIT NO. 30

- 1 all-wave coil, with 2-gang spindle.
- 1 2-gang condenser, Bar type .0005 mfd. (C₁, C₂).

- 1 S.M. drive, with station names.
- 1 differential reaction condenser, .0003 mfd. (C₃).
- 1 potentiometer, 50,000 ohms. with 3-point switch (R₁).
- 1 L.F. transformer, type AF8.
- 7 fixed condensers: 2 2 mfd. (C₇, C₁₀), type 65, 1 .0001 mfd. (C₆), 1 .0005 mfd. (C₄), 1 .005 mfd. (C₉), 1 .01 mfd. (C₈), 1 .1 mfd. (C₅).
- 7 fixed resistances: 1 1-meg. (R₃), 3 .5-meg. (R₂, R₆, R₈), 1 100,000-ohms. (R₇), 1 50,000-ohms. (R₄), 1 15,000-ohms. (R₅), type F $\frac{1}{4}$.
- 4 valveholders: 4-pin chassis mounting.
- 2 socket strips, A.E. and L.S.
- 2 component brackets.
- 1 chassis, 12 in. x 8 in. x 3 in. (ready drilled for valveholders).
- 8 plugs: H.T.-, H.T.1, H.T.2, H.T.3, G.B.+ , G.B.-1, G.B.-2, G.B.-3 midget type.
- 2 spades, L.T.-, L.T.+.
- 4 valves: variable-mu pentode, 2 detector valves, and a small power valve.
- 1 fuse and holder, 100 m/A.
- 1 speaker.
- 1 H.T. battery, 120-volt.
- 1 G.B. battery, 9-volt.
- 1 accumulator, 2 volt.

Circuit No. 31.—Fig. 72 shows another very lightweight portable battery type of receiver. The circuit is quite orthodox, employing an S.G.H.F. stage, detector, Driver, and Class B valves and thus provides a large output. A diagram is given (Fig. 73) showing the connections to the terminals, and to enable this particular unit to provide maximum results it is suggested that the H.F. coupling condenser be reduced in capacity to .0003 mfd.

The framework of the cabinet is constructed from strip-wood 1-inch wide by $\frac{1}{4}$ -inch thick and this is screwed together by means of short metal strips. The following illustrations show the method of building it and give all dimensions. The opening or speaker grille is $5\frac{1}{2}$ inches in diameter, and is covered on the inside with silk or the special fabric obtainable from any good radio dealer. The cabinet is afterwards covered with leatherette glued in position and a carrying handle is attached to the cross strips on the upper surface. The front of the cabinet is attached by hinges to the lower edge so that it may be lowered to insert the batteries and make tests or voltage measurements.

The frame aerial is wound on the inside of the front, spacing strips of ebonite being screwed diagonally in the four corners. These strips are no longer on the market, but may be made by obtaining a piece of $\frac{3}{8}$ inch ebonite and cutting strips half an inch wide and $2\frac{1}{2}$ inches in length.

Drill holes at each end so that they may be screwed to the front of the cabinet and then with a hacksaw make eight cross cuts about $\frac{1}{4}$ inch deep, followed by two further slots made by making two cuts and breaking out the intervening piece of ebonite so that these two slots are nearly $\frac{1}{2}$ of an inch in width. All of the slots should be cut at an angle so that when the wire is wound in it will be prevented from falling out. One end of the 24-gauge wire is soldered to the upper right-hand contact of the tuning condenser and the wire is then passed across to the upper slot of the nearest spacer. Run the wire across to the left, through the upper slot on the left-hand spacer and down to the lower spacer, across

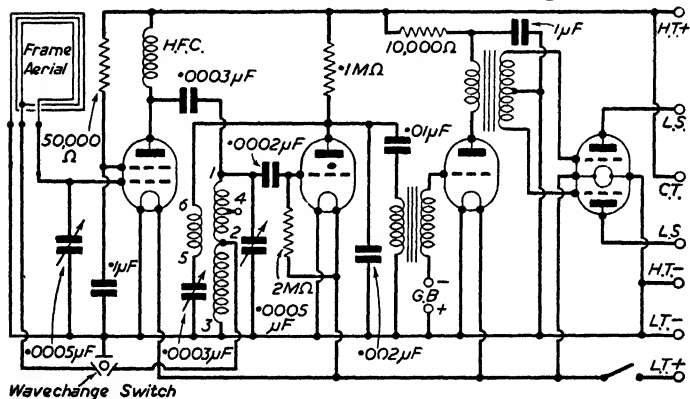

FIG. 72.—Circuit No. 31 for Lightweight Portable Battery Four-valve.

the lower edge, and so continue to the slot where you commenced. Carry the wire through this slot again, and make a further turn, repeating the process so that there are three turns in the first slot. Pass to the second slot, and wind three turns in this, after which two turns only are wound in each remaining slot until eight slots have been used. There now remains the two wide slots. The end of the 24-gauge wire must be cut, and it should be soldered, together with the beginning of the 34-gauge wire to the upper terminal of the 3-point switch. The long-wave winding consists of 23 turns in each slot, and the finish of the winding is joined to the lower terminal of the left-hand tuning condenser. Upon completion of the frame aerial winding the slots may

be sealed with sealing-wax or Chatterton's compound. (See also Figs 74 to 78.)

Normally the receiver should be perfectly stable in operation, but it was originally found that due to the compact form taken by the receiver a few constructors experienced instability. This was due to the fact that they had run many of the wires too close together, and thus the first step to take if this trouble is experienced is to space out the wiring as much as possible. Initially, no screening of leads should be introduced, but if it is found impossible to obtain stable working the lead from the anode of the S.G. valve

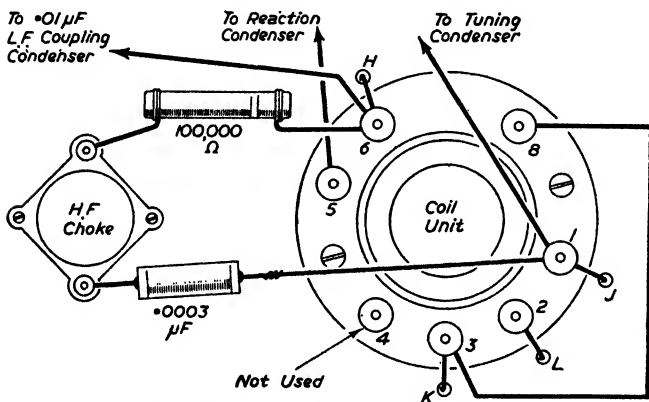
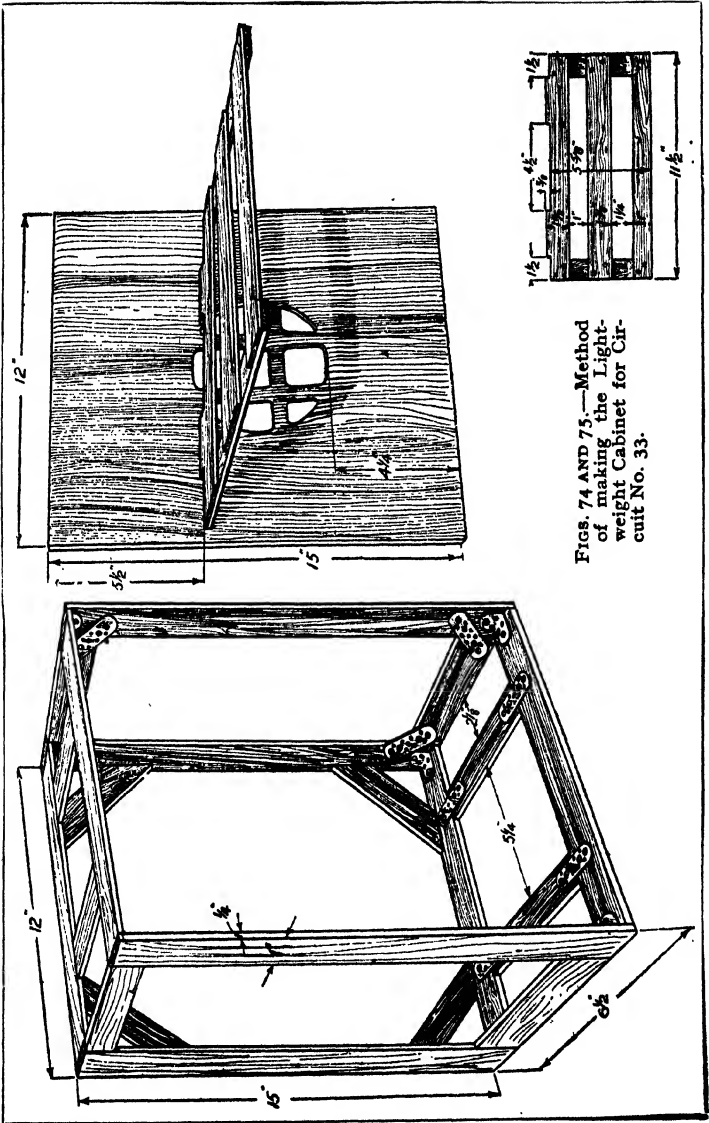

FIG. 73.—Connections for the Bulgín coil, Type C22, which is used in Circuit No. 31.

may be passed through a length of ordinary screened sleeving and the sleeving connected by means of a short length of wire to the nearest earth terminal. The leads to the reaction condenser may also be screened in a similar manner, whilst in a very severe case of instability the two leads to the loud-speaker may also be similarly screened. It must be emphasised, however, that such extreme screening should not be necessary unless the wiring is very badly carried out or some other difficulty arises. The voltages applied to the various parts will occasion no difficulty. The H.T. positive lead is inserted into the maximum voltage socket on the H.T. battery and the two L.T. leads are connected to the appropriate terminals on the accumulator. The Grid Bias positive lead



Figs. 74 AND 75.—Method of making the Light-weight Cabinet for Circuit No. 33.

is inserted into the positive socket on the G.B. battery and the negative lead should be inserted into the 9-volt socket, although where economy is not such an important item, this may be reduced to 7.5 volts. The latter voltage will enable slightly more volume to be obtained, although the anode

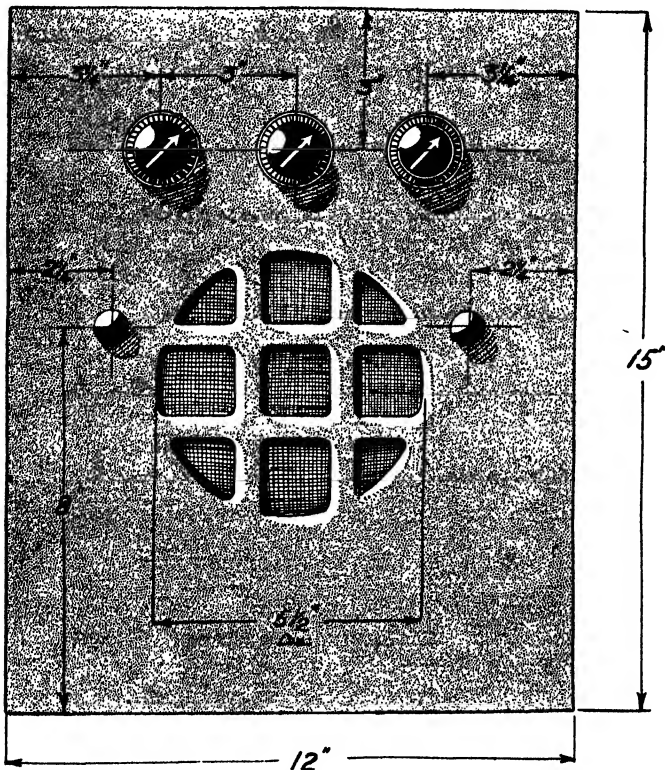

FIG. 76.—Drilling dimensions for the swinging front of Cabinet for Circuit No. 31.

current consumption will be increased. Therefore, the user of this particular receiver may experiment with voltages between 4.5 and 9 volts in order to find the voltage which gives the most satisfactory volume compatible with economy of operation. Finally, the two outside controls on the panel

front are for tuning and must be kept more or less in step, the centre control operating the reaction condenser. Do not

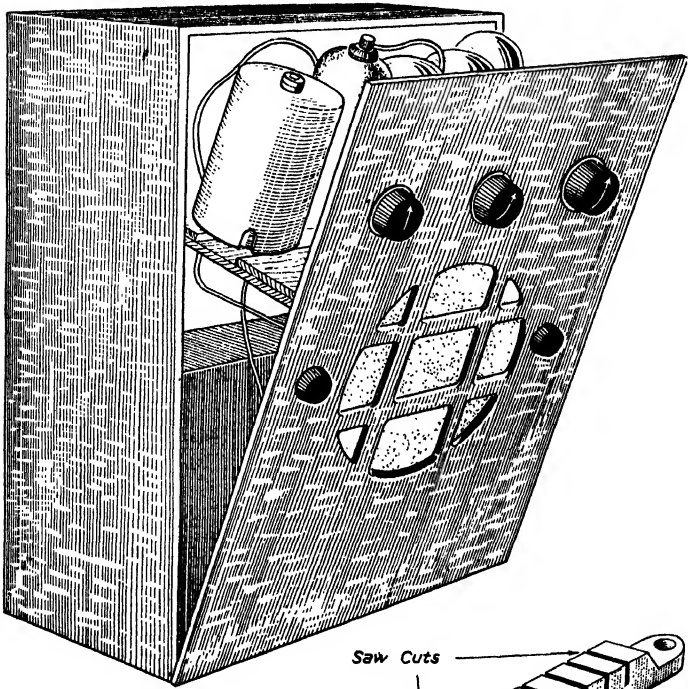

FIG. 77.— Shows the finished Receiver, with the fall front.

forget that a portable with a self-contained frame aerial of this type must be orientated so that the directional properties of the frame are utilised. Maximum volume is obtained when the frame is in a line with the station being received.

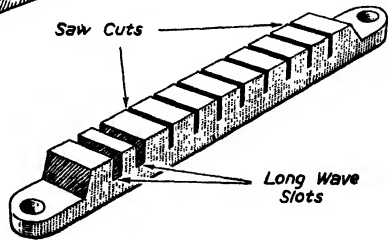

FIG. 78.— Spacers for the Frame Aerial of Circuit No. 31 may be constructed as shown here from strip ebonite.

LIST OF COMPONENTS FOR CIRCUIT NO. 31

- 2 bakelite variable condensers, .0005 mfd.
- 1 .0003 variable condenser.
- 1 H.F. choke.
- 1 Dual Range coil.
- 1 10,000 ohm wire-end resistor.
- 1 50,000-ohm wire-end resistor.
- 1 100,000-ohm wire-end resistor.
- 3 4-pin chassis type valveholder.
- 1 7-pin chassis type valveholder.
- 1 on-off switch.
- 1 3-point wavechange switch.
- 1 Class B. driver transformer.
- 1 2-megohm grid leak with wire ends.
- 1 .01 mfd. fixed condenser.
- 1 .0002 mfd. fixed condenser.
- 1 .0003 mfd. fixed condenser.
- 1 .002 mfd. fixed condenser.
- 1 .1 mfd. fixed condenser.
- 1 1.0 mfd. fixed condenser.
- 1 220 S.G. valve (metallised).
- 1 210 H.F. valve (metallised).
- 1 215 P. valve.
- 1 240 B. valve.
- 1 loud-speaker, Class B.
- Quantity 24 D.C.C. and 34 D.S.C. wire for aerial.
- 1 120-volt H.T. battery.
- 1 9-volt G.B. battery.
- 1 2-volt accumulator.
- 4 wander plugs, H.T. —, H.T. —, G.B. — and G.B. —.
- 2 spades, L.T. — and L.T. —.
- Connecting wire, flex, screws, wood for case, leatherette, carrying handle and hinges.

Circuit No. 32.—This (Fig. 79) is an ambitious 4-valve set designed to bring in as many stations as possible at good quality. The values are critical, and no attempt should be made to alter them. The use of variable-mu H.F. valves is not recommended in this particular instance, but the addition of a Class B output stage could be carried out. The best arrangement of the tuning circuits is carried out by using a two-gang condenser to tune the first two circuits, and a single condenser for the remaining (detector) circuit. A good moving coil loud-speaker is worth while with this set, and the selectivity is regulated by reducing the efficiency

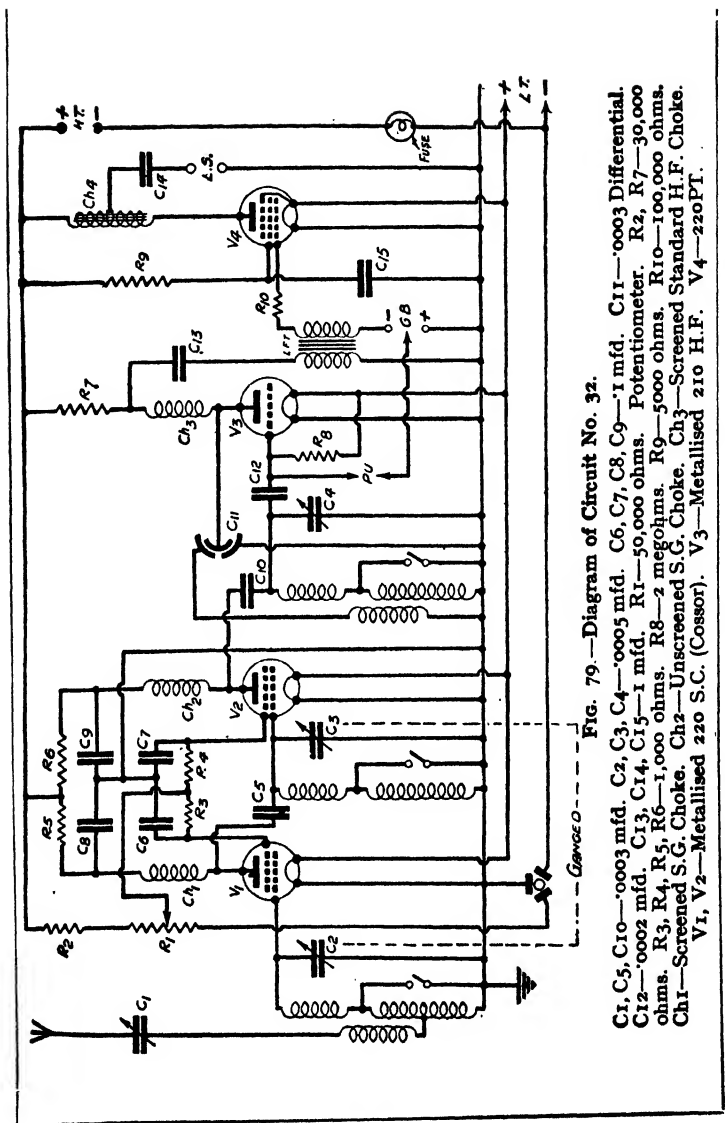

Fig. 79.—Diagram of Circuit No. 32.

C1, C5, C10—0.003 mfd. C2, C3, C4—0.005 mfd. C6, C7, C8, C9—1 mfd. C11—0.003 Differential. C12—0.002 mfd. C13, C14, C15—1 mfd. R1—50,000 ohms. Potentiometer. R2, R7—30,000 ohms. R3, R4, R5, R6—1,000 ohms. R8—2 megohms. R9—5000 ohms. R10—100,000 ohms. Ch1—Screened S.G. Choke. Ch2—Unscreened S.G. Choke. Ch3—Screened Standard H.F. Choke. V1, V2—Metallised 220 S.C. (Cossor). V3—Metallised 210 H.F. V4—220P.T.

of the H.F. valves (by means of the potentiometer R1), and increasing signal strength by adjustment of the reaction condenser. In this way the maximum punch may be obtained when conditions do not demand selectivity. The total consumption of this set is about 20 milliamps, so that care should be taken to obtain a really suitable mains unit when it is desired to operate this from the electric light mains.

LIST OF COMPONENTS FOR CIRCUIT NO. 32

- 1 3-gang coil assembly.
 - 1 2-gang condenser with disc drive.
 - 1 .0005-mfd. single condenser with disc drive.
 - 1 .0003-mfd. compression type condenser.
 - 2 S.G. chokes.
 - 1 screened H.F. choke.
 - 1 L.F. transformer, ratio 3 to 1.
 - 1 pentode output choke.
 - 3 1-mfd. fixed condensers.
 - 2 .0003-mfd. fixed condensers.
 - 1 .0002-mfd. fixed condenser.
 - 2 .1 + .1 C.-mfd. fixed condensers.
 - 4 chassis-mounting valve-holders, 3 4-pin and 1 5-pin.
 - 4 1000-ohm resistors, 1-watt type.
 - 2 30,000-ohm resistors, 1-watt type.
 - 1 100,000-ohm resistor, 1-watt type.
 - 1 5000-ohm resistor, 1-watt type.
 - 1 2-megohm grid leak with wire ends.
 - 3 terminal blocks.
 - 1 4-way battery cord.
 - 6 terminals, marked aerial, earth, pick-up, pick-up, L.S. and L.S. (Type B).
 - 1 fuse-holder, with fuse.
 - 1 50,000-ohm potentiometer.
 - 1 .0003-mfd. differential reaction condenser.
 - 1 3-point switch.
 - 1 ebonite panel, 16 in. x 8 in.
 - 3 wander plugs, G.B. +, G.B.1, and G.B.2.
 - 2 Cossor valves, Type 220 S.G. (metallised).
 - 1 Cossor valve, Type 210 H.F. (metallised).
 - 1 Cossor valve, Type 220 PT.
 - 2 coils of insulated connecting wire.
- Sundry screws, soldering tags, etc.

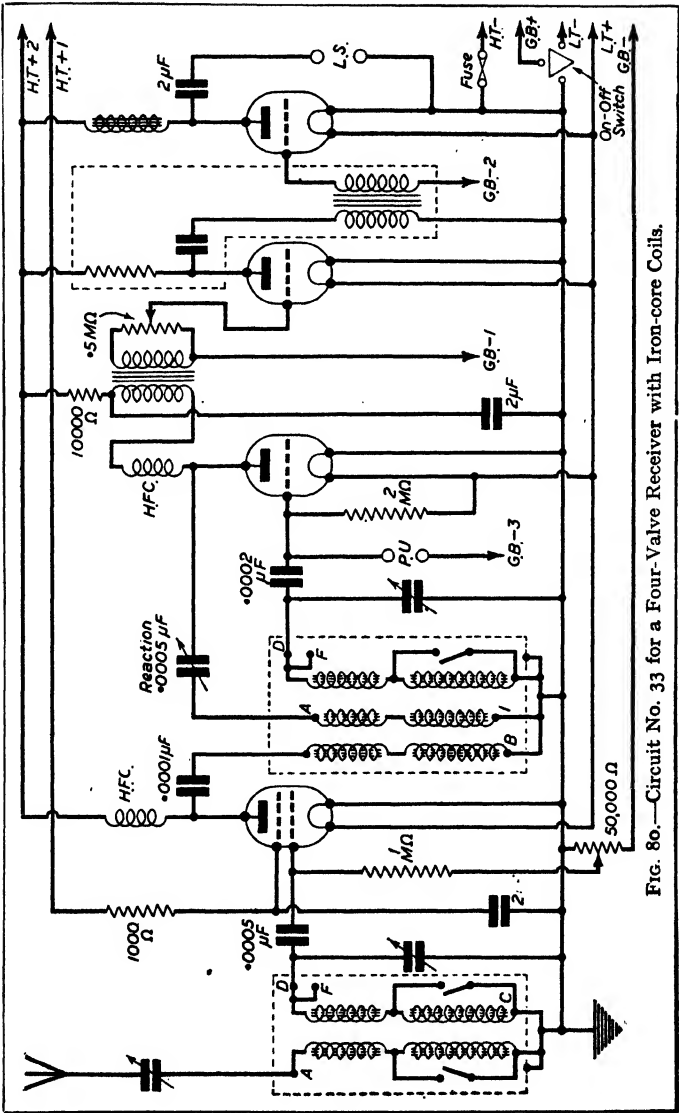

FIG. 80.—Circuit No. 33 for a Four-Valve Receiver with Iron-core Coils.

Circuit No. 33.—This is a four-valve receiver (Fig. 80) utilising a ganged iron-core tuning coil unit tuned by a 2-ganged condenser. The first valve is of the standard variable- μ H.F. pentode type, and an ordinary triode is used as a leaky grid detector. This feeds an L.F. valve which in turn is coupled to a small power valve, and the coupling employed in the L.F. stages is mixed—one stage using a standard transformer, and the other stage a special component consisting of a combination of resistance-capacity and L.F. transformer. The output from a receiver of this type is large enough for all normal entertainment purposes, and a large number of stations can be received owing to the efficient H.F. stage.

This receiver is ideal for the beginner as all of the components are mounted on a flat baseboard instead of the more usual chassis, and this makes it easier to build and wire the receiver, and at the same time facilitates testing. The baseboard is not covered with foil or otherwise prepared, and an ordinary sheet of thick ply-wood may be used for it. It will be noted that an earth return point is made use of by connecting to the screw used to hold down the 2-gang coil unit. To simplify tuning the condenser should be of a type having a small trimmer mounted on it, operated by means of a knob concentric with the main tuning knob. This enables tuning to be compensated and any slight inaccuracies in the tuning circuit may thus be overcome and at the same time slight mistuning which arises when reaction is employed is also balanced out. The volume control which is specified should be of the type having a switch mounted on it, so that the number of controls are reduced to a minimum. It will be noticed that the grid bias circuit is completed through this switch and thus when the set is switched off the grid bias circuit is also broken. This point is of great importance as if the grid bias circuit is not open when the set is not in use the grid bias battery will discharge itself through the potentiometer. Certain types of volume control of this kind have four points on the switch and two of these should be linked together to act as a single point—the makers usually supply the details for making this connection.

The components may be mounted on brackets screwed to the baseboard, or alternatively may be mounted direct on the cabinet front, and wired direct to the circuit, or preferably a wooden or ebonite panel may be screwed to the front of the baseboard and the components mounted on this.

It would then be necessary to use a cabinet having an open front through which the controls would be accessible.

Connections to the battery are carried out through a 5-way battery cord and by using one of the special types having colour coded leads, and coloured plugs, it will be a

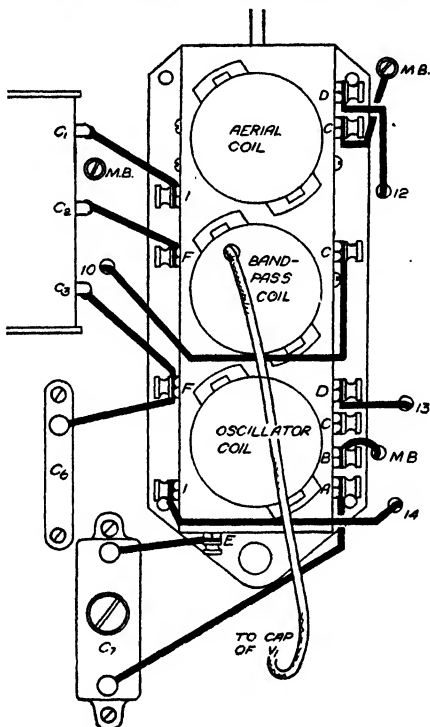

FIG. 81.—Coil Connections for Circuit No. 33.

simple matter always to ensure that the correct voltages are applied to the different stages and damage thereby avoided.

LIST OF COMPONENTS FOR CIRCUIT NO. 33

- 1 2-gang unit (aerial and H.F. transformer).
- 1 2-gang .0005-mfd. condenser with concentric trimmer.
- 1 .0003-mfd. pre-set condenser.

- 1 .003-mfd. reaction condenser.
- 3 2-mfd. fixed condensers.
- 1 .0002-mfd. condenser.
- 1 .0001-mfd. condenser.
- 1 .0005-mfd. condenser.
- 1 standard screened H.F. choke.
- 1 H.F. choke.
- 1 L.F. choke.
- 1 3-1 L.F. transformer.
- 1 parallel-fed transformer.
- 1 1,000 ohm., 1-watt resistor.
- 1 10,000-ohm. 1-watt resistor.
- 1 2-megohm grid leak.
- 1 20,000-ohm. volume control with 3-point switch.
- 4 4-pin valveholders baseboard type.
- 1 500,000-ohm. volume control.
- 1 100 m/A. microfuse and holder.
- 3 terminal mounts.
- 6 terminals, A. E. Ls —, Ls +, P.U., and P.U.
- 1 Five-way battery cord.
- 5 wander plugs, G.B. —, G.B. +, G.B.1, G.B.2, G.B.3.
- 2 coils connecting wire.
- 1 120-volt H.T. battery.
- 1 9-volt G.B. battery.
- 1 2-volt L.T. accumulator.
- 1 loud-speaker.
- 4 valves: variable-mu, pentode, 1 general purpose valve, 1 small power valve, and 1 super-power valve.

Circuit No. 34.—This circuit (Fig. 82) is a very popular and satisfactory three-valve superhet giving maximum selectivity, great range of reception, and employing a Westtector as a second detector in place of a valve. This gives economy of operation and enables the receiver to be operated from a small L.T. and H.T. battery. A standard pentagrid frequency changing valve is used and this together with the I.F. valve is of the variable-mu type and enables the volume to be controlled by means of a potentiometer mounted on the panel. A pentode is employed in the output stage and is fed by means of an L.F. transformer connected as a choke giving increased ratio. Unfortunately, owing to the fact that there is only one L.F. stage it is not practical to use their receiver for gramophone record amplification with a pick-up.

The input circuit consists of a pair of band-pass coils and this gives high selectivity and prevents trouble from second channel interference, and these two coils are ganged with a third which acts as the oscillator coil. It is essential when purchasing the three-gang condenser to ask for a superhet type component designed for an intermediate

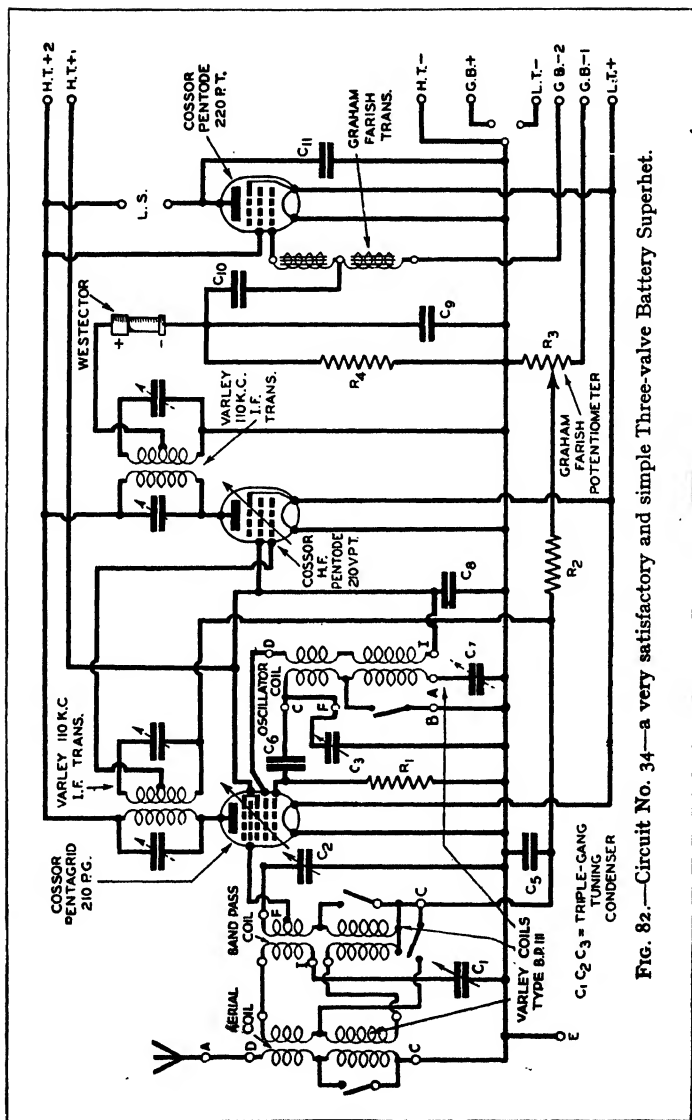

FIG. 82.—Circuit No. 34—a very satisfactory and simple Three-valve Battery Superhet.

frequency of 110 kilocycles and with the oscillator section furthest from the panel. If this is not done the wiring to the gang condenser will be inefficient or if the blueprint is followed explicitly the oscillator section will be connected across the wrong coil. Before maximum results can be obtained from a superhet the circuits must be correctly trimmed, and this is the greatest difficulty in modern receiver operation. The most effective way of carrying out the trimming is to use a properly calibrated oscillator, but if this is not available you should obtain I.F. transformers ready adjusted by the makers when they will not require a great deal of readjustment. The procedure for trimming is as follows: First turn the hexagonal nuts on the I.F. trimmers so that they are nearly tight, in a clockwise direction. Next turn the concentric screws inside the hexagonal nuts in an anti-clockwise direction so that they also are nearly tight. This will bring the primary and secondary windings to approximately 110 kilocycles. The trimmer C₃ should then be turned to approximately half a turn from the full-in position (clockwise rotation), after which C₁ and C₂ trimmers are turned to provide maximum volume on the local station. A distant station should then be located and a final adjustment of the various trimmers made. It should be remembered that unless the correct I.F. is located on the transformers, and the correct frequency-separation is obtained in the oscillator stage, the tuning will not hold throughout the dial, and thus good results will be obtained at one end of the dial, and perhaps no signals at all at another part of the dial. The long-wave padding condenser, C₇ is only adjusted on long waves, and no alteration of the trimmers already mentioned should be carried out on long waves.

LIST OF COMPONENTS FOR CIRCUIT NO. 34

- 1 set of 3-gang superhet coils.
- 1 3-gang superhet midget variable condenser, and disc drive.
- 2 I.F. transformers.
- 1 .002-mfd. pre-set condenser (C₇).
- 1 50,000-ohm. potentiometer (R₃).
- 1 1-mfd. fixed condenser (C₈).
- 2 .5-mfd. fixed condensers (C₅ and C₁₀).
- 1 .01-mfd. tubular condenser (C₁₁).
- 2 .0001-mfd. fixed condensers (C₆ and C₉).
- 3-ohm. resistances, 150,000 (R₁), 100,000 (R₄), 30,000 (R₂) ohms.
- 1 max. L.F. transformer.

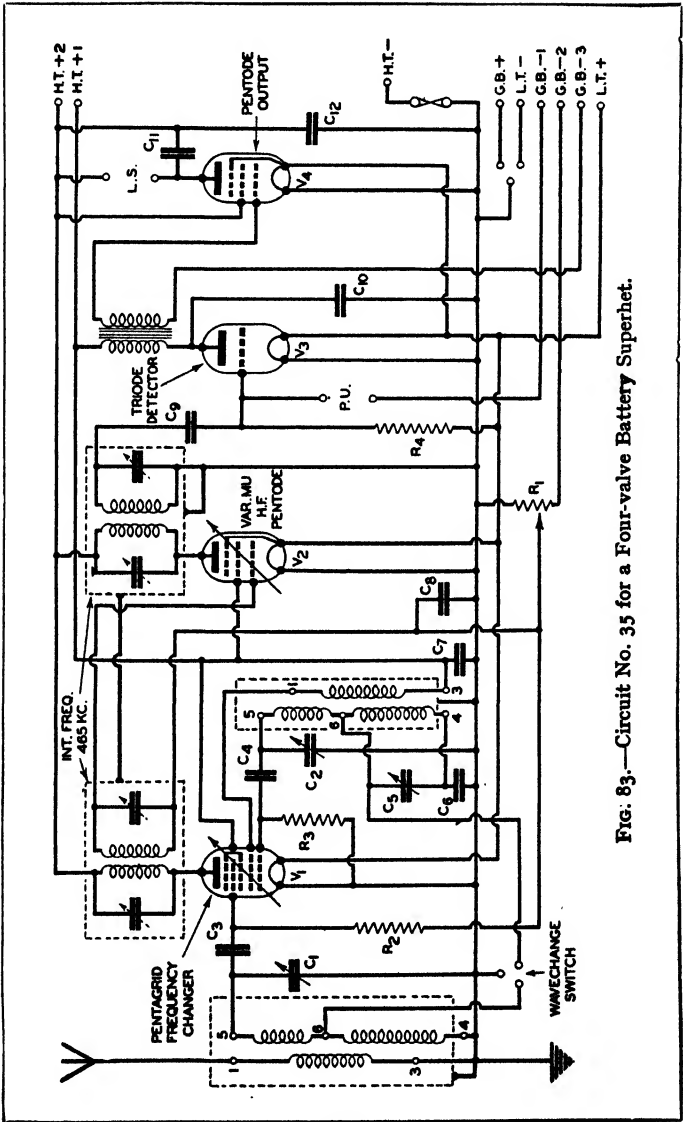

Fig. 83.—Circuit No. 35 for a Four-valve Battery Superhet.

- 1 potentiometer bracket.
- 1 3-point on-off switch.
- 1 7-pin sub-baseboard valveholder.
- 1 5-pin sub-baseboard valveholder.
- 1 4-pin sub-baseboard valveholder.
- 1 Westector.
- 3 wander plugs (H.T. +1, H.T. +2, H.T. -).
- 2 spade terminals (L.T. +, L.T. -).
- 3 G.B. plugs (G.B. +, G.B. -1, G.B. -2).
- 2 terminal strips (A.E. and L.S.).
- 1 Metaplex chassis 11 in. x 10 in., with 2½ in. runners.
- 3 valves: 1 pentagrid, 1 variable- μ H.F. pentode, and 1 economy pentode.
- 1 loud-speaker.
- 1 120-volt H.T. battery.
- 1 G.B. 16½-volt battery.
- 1 L.T. 2-volt accumulator.

Circuit No. 35.—This is a four-valve superhet, the first valve fulfilling two separate functions, thus making the set equivalent to a five-valve receiver. The aerial circuit is a simple H.F. transformer, a simple aperiodic winding serving for both medium and long waves. The circuit is shown in Fig. 83. The component which is used is provided with a tapping point provided for wave-change purposes, but it has been found necessary to use this in the present circuit. The secondary winding is fairly closely coupled which is brought out to a three-point switch mounted beneath the chassis whilst the entire coil is enclosed in a metal screening can. The signal is tuned by the first section of a ganged condenser in the ordinary way, and is applied direct to the grid and filament of the frequency-changer valve. Bias is applied direct to the grid through the volume control potentiometer and resistance R₂, a condenser C₃ being interposed in the grid lead to prevent short circuiting of the bias voltage.

Arranged in the same valve are two further grids, to one of which is joined a tuned circuit coupled to a coil which is included between the other grid and the H.T. battery. This is, of course, a standard reaction arrangement, and the grid in this case functions as an anode. As a result of this arrangement, oscillation takes place and the moving vanes of that section of the gang condenser marked C₂ are cut to a certain shape which causes the tuning in this circuit to be 465 kilocycles above the frequency to which the first coil is tuned. An anode is arranged around the grids which have already been referred to (in addition to a screening grid which functions in the normal manner), and thus a mixed

stream of electrons is found passing from the filament to anode. This mixture consists of the original signal tuned by condenser C1 to which are added the oscillations produced in the oscillator coil or section, and so at the anode appears the difference, as a beat note upon which are superimposed the fluctuations of the original signal. The rectification of the original signal impulses have not been referred to, although, in addition to the above mixing, the complication of partial rectification takes place. To enable the condenser C2 to tune the coil over both medium and long-waves, it is necessary to add some additional capacity to the total circuit, and to increase the general "stray" capacity across the coil a pre-set condenser C5 is included, whilst condenser C6 is added in series with the coil. These two condensers are, of course, short-circuited when medium-wave reception is desired, and the same switch as is used for the aerial is employed for this purpose. In the anode circuit of this first valve a transformer is inserted, and this is designed to be tuned to a frequency of 465 kilocycles—small pre-set condensers being included across both primary and secondary to balance out stray capacities. Thus, when each of these windings is correctly adjusted we shall find the original signal impulses present in primary and secondary, but being borne at a frequency of 465 kilocycles instead of the frequency originally received in the aerial circuit. Amplification is next carried out by the variable-mu H.F. pentode in the usual manner, variable bias being applied direct to the grid through the secondary winding of the I.F. transformer, and a similar component is included in the anode circuit of this valve to transfer the signal to the next valve, which is known as the second detector. This is arranged to function on the usual grid-leak rectifier principle, and thus in the anode circuit of this valve we find our signal in the form of an audio or low-frequency impulse which may be employed to operate a loud-speaker or head-phones, or be further amplified at low frequency.

It is obvious from the previous description that great selectivity will be obtained with a circuit of this nature, as apart from the number of tuned circuits employed (there are actually six of these), the production of the beat note in the frequency changing stage adds still further to the selectivity, and thus it becomes possible to obtain such a high degree of selectivity that the musical side-band of the transmitted signal may be cut. Obviously, this is not desirable in the

interests of quality reception, and therefore the general arrangement of the circuit is such that the selectivity reaches just that stage which ensures that a separation equivalent to the band of frequencies which are broadcast is obtained, and provided that a signal is not actually heterodyned due to another station working within the allowed frequency band, it is possible to separate every broadcasting station from its neighbour.

To remove such mush and noises accompanying some of the foreign stations which work rather close in frequency, a simple tone-control device has been incorporated in the anode circuit of the output valve, and this acts very effectively in removing the background noises without spoiling quality. Further tone control is not desirable, if good quality signals are desired, although if it is found that in certain parts of the country a station is required for regular reception but is spoiled by a heterodyne, a high-note cut-off may be introduced. It can only result in a spoiling of the musical quality and I do not recommend such a drastic step.

LIST OF COMPONENTS FOR CIRCUIT NO. 35

- 1 screened aerial transformer.
- 1 screened oscillator coil.
- 1 2-gang variable condenser with V.P. horizontal drive.
- 1 compression condenser (.0001 mfd.) (variable) (C₅).
- 2 .0001-mfd. fixed condensers (C₄ and C₉).
- 1 .0004-mfd. fixed condensers (C₆).
- 1 .0005-mfd. fixed condensers (C₃).
- 1 .001-mfd. fixed condensers (C₁₀).
- 1 .003-mfd. fixed condensers (C₁₁).
- 1 .01-mfd. fixed condensers (C₈).
- 2 .5-mfd. fixed condensers (C₇ and C₁₂).
- 1 100,000-ohm. non-inductive 1-watt fixed resistance (R₃).
- 1 .5-megohm non-inductive, 1-watt fixed resistance (R₂).
- 1 1-megohm non-inductive 1-watt fixed resistance (R₄).
- 1 50,000-ohm. with 3-point switch variable resistance (R₁)
- 2 I.F. transformers.
- 1 L.F. transformer (ratio 1-3).
- 1 3-point shorting switch.
- 2 4-pin valveholders (with terminals).
- 1 5-pin valveholder (with terminals).
- 1 7-pin valveholder (with terminals).
- 1 terminal strip marked A.E.
- 1 terminal strip marked P.U. and L.S.
- 7 wander plugs, marked G.B.-1, G.B.-2, G.B.-3, G.B.+,
H.T.+1, H.T.+2, H.T.-.
- 2 spade connectors marked L.T.- and L.T.-.

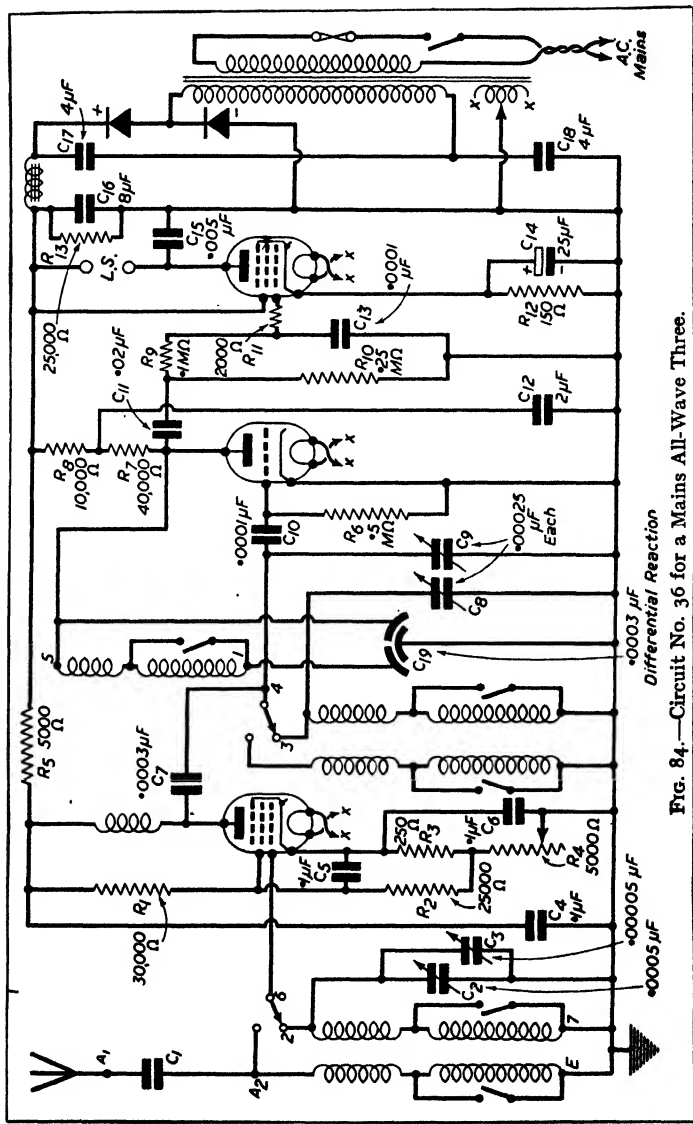

Fig. 84.—Circuit No. 36 for a Mains All-Wave Three.

- 1 100 m/A. and holder.
 - 1 pentagrid valve.
 - 1 variable- μ H.F. pentode valve.
 - 1 triode valve.
 - 1 L.F. pentode valve.
 - 1 metaplex chassis measuring 10 in. \times 8 in. with 3 in. runners.
 - 2 $2\frac{1}{4}$ in. component brackets.
 - 1 loud-speaker.
 - 1 120-volt H.T. battery.
 - 1 16.5-volt G.B. battery.
 - 1 2-volt L.T. accumulator.
- Connecting wire, screws, etc.

Circuit No. 36.—This circuit (Fig. 84) is the mains version of the battery all-wave three shown in Circuit No. 23. The circuit arrangement is the H.F. detector, L.F. type, using pentode valves in the H.F. and L.F. stages and a triode detector. The aerial circuit is tuned on the medium and long-wave bands, and untuned when switched to the short-wave bands. The primary winding of the medium long-wave-coil acts as an effective H.F. choke when the switch is in the short-wave position. The switch is incorporated in the coil unit, and can be obtained completely wired by the manufacturers. The H.F. valve is of the variable- μ pentode type, having 7-pins, and volume is controlled by means of a 5000 ohms potentiometer connected in series with its cathode resistance. The coupling between the H.F. and detector valves is of the tuned grid type, the H.F. choke being of a modern screened type. It will be noted that the tuning arrangement in this stage is of a novel type. The wavechange switch connects two .00025 mfd. sections of the gang condenser in parallel on the medium and long wavebands thus forming a capacity of .0005 mfd. On the short-wavebands one of these .00025 mfd. sections is disconnected leaving a tuning condenser of .00025 mfd. Resistance capacity coupling is used between the detector and output valve to avoid the possibility of mains hum which might otherwise be caused by interaction between the L.F. amplifier and the mains unit. Resistance coupling also ensures good quality reproduction, and by using a high efficiency pentode in the output stage adequate volume is obtained. The rectifier used in the mains unit is of the Westinghouse metal type. This was chosen owing to its reliability and consequent popularity amongst home-constructors. Style H.T.9 may be used, but style H.T.8 may be employed if one of these is on hand. The H.T.8 has now been discontinued, style H.T.9 taking its place. An

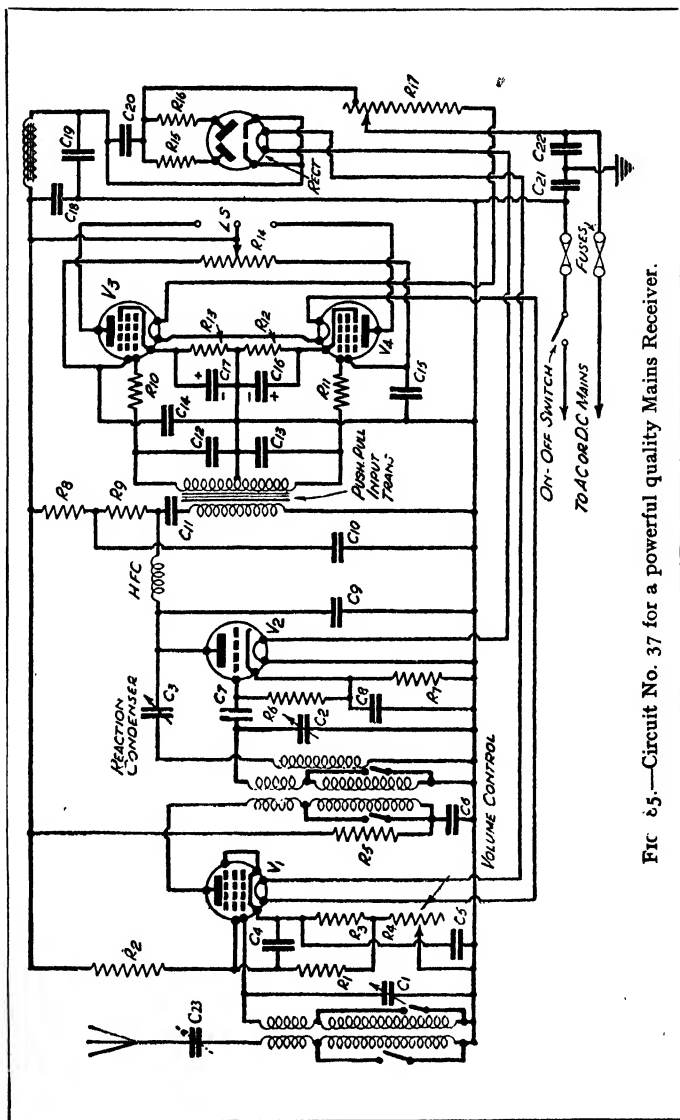

FIG 85.—Circuit No. 37 for a powerful quality Mains Receiver.

explanation of the function of resistance R.13 is probably called for. This* has been added owing to the use of an indirectly heated output valve. It acts as a loading resistance and prevents damage occurring to the rectifier and smoothing condensers during the time the output valve is heating up.

LIST OF COMPONENTS FOR CIRCUIT NO. 36

- 1 all-wave coil unit.
- 1 3-gang ($\cdot 0005 + \cdot 00025 + \cdot 00025$) condenser (C2, C8, C9).
- 1 drive with trimmer (SL9), (C3).
- 12 fixed condensers: 8-mfd. (F2920), (C16), $4\frac{1}{4}$ -mfd. block (BE355) (C17, C18), 2-mfd. (BB) (C12), $\cdot 02$ -mfd. (C11), $\cdot 005$ -mfd. (C15), $\cdot 0003$ -mfd. (C7), two $\cdot 0001$ -mfd. (4421/E) (C10) and (C13), three $\cdot 1$ -mfd. (4423/S), (C4, C5, C6), 25-mfd. (3016/25V) (C14).
- 11 fixed resistors: 40,000 (R7), 30,000 (R1), 25,000 (R2), 10,000 (R8), 5000 (R5), 250 (R3), 150 (R12) (F1), 500,000 (R6), 250,000 (R10), 100,000 (R9), 2000 (R11), (F4).
- 1 all-wave H.F. choke (H.F. 15).
- 1 power resistor, 25,000 ohms. (R.13) (PR14).
- 1 potentiometer 5000 ohms. (R4) (CP157).
- 1 L.F. choke (DP11).
- 1 metal rectifier (H.T.9).
- 1 mains transformer (W31).
- 1 fuseholder with 1 amp. fuse.
- 1 Q.M.B. switch.
- 2 terminal sockets, 1 L.S. and A.E.
- 2 component brackets.
- 3 valveholders; 2 7-pin, 1 5-pin.
- 1 metallised chassis $14 \text{ in} \times 10 \text{ in.}$ with $3\frac{1}{2}$ in. runners.
- 2-ft. length metal screened lead.
- 3 valves: variable-mu pentode, detector, and power pentode.
- 1 speaker.

Circuit No. 37.—Fig. 85 shows the circuit of a powerful mains receiver suitable for high quality reproduction of the local stations with a fair number of distant stations. For this purpose at least one good H.F. stage must be employed, whilst to ensure good quality powerful loud-speaker signals, a push-pull stage employing two pentodes is ideal. To cover the various mains supplies which may be used, a Universal circuit will be found necessary, and thus the complete receiver may be aptly described as a Universal Four-Valve Receiver, the circuit of which is reproduced on page 115. A full list of components is given below, and for those readers who now wish to build a set of this type, a full-size blueprint is available, number P.W.47. Although a more

or less standard arrangement there are one or two points of interest in this circuit which require explanation. Firstly, a single tuned circuit is employed for the first stage and also for the detector stage, but this should provide adequate selectivity for all normal requirements. Where excessive interference is experienced, such as when the receiver is

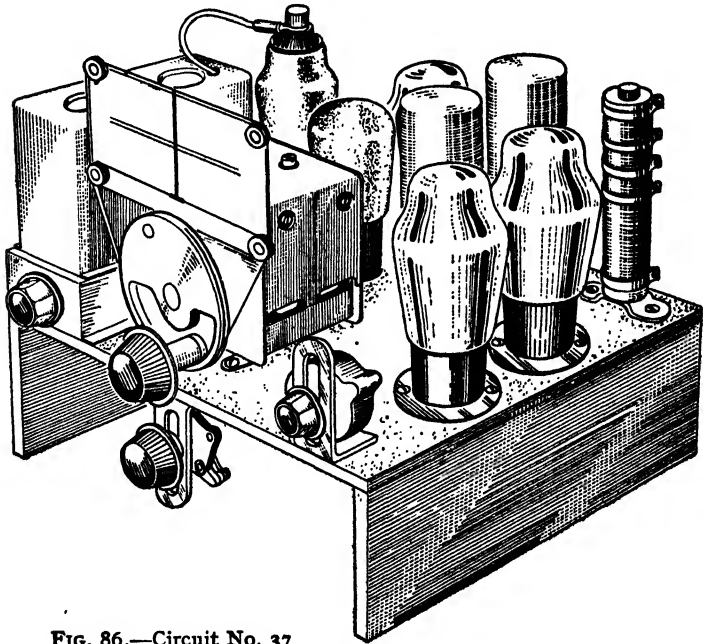

FIG. 86.—Circuit No. 37
as built.

required for use close to a main B.B.C. station, a band-pass tuner could, of course, be employed in the aerial circuit and this would entail the use of a three-gang condenser in place of the two-gang component now specified. The detector stage is quite normal, and it will be noted that a biasing resistor and condenser are included in the cathode circuit of the detector stage.

A pick-up may therefore be used, when required, by connecting it between the grid of this valve and the earth

line (chassis). On the output side several devices have been included in the interests of stability and quality. Firstly, the transformer is parallel-fed to remove the current from the primary and to give an improved low-note response. Secondly, two fixed condensers are connected across the secondary (C12 and C13) and this assists in improving the quality and range of the lower musical frequencies. To ensure stability a resistance is included in series with each of the output grids and a further device for this purpose consists of the inclusion of a potentiometer across the two valves. This potentiometer supplies the voltages to the two screening grids and it will be seen that the arm of the control is joined to H.T. positive. With the aid of this control it is possible to effect a balance between the two valves which will in many cases have the effect not only of improving stability but also of improving quality, especially where the two output valves are not well matched. If, however, when you build this receiver, you find that the adjustment of this control does not have any noticeable effect, it will simply indicate that the two output valves are fairly well matched and it should then be adjusted to a mid-way position and there left. The remaining part of the circuit, supplying the H.T. is orthodox, a full-wave rectifying valve being connected on the half-wave principle and adequate smoothing devices being included to remove possibility of mains hum.

LIST OF COMPONENTS FOR CIRCUIT NO. 37

- 1 2-gang set coils.
- 1 2-gang .0005-mfd. midget condenser with drive and wavelength scale.
- 1 .00015-mfd. reaction condenser.
- 4 .5-mfd. fixed tubular condensers (C6, C11, C14, C15).
- 2 .1-mfd. fixed tubular condensers (C4 and C5).
- 3 .05-mfd. fixed tubular condensers (C20, C21, C22).
- 1 .0001-mfd. fixed tubular condensers (C7).
- 3 .0002-mfd. fixed tubular condensers (C9, C12, C13).
- 1 2-mfd. fixed condenser (C10).
- 3 25-mfd. electrolytic condensers (C8, C16, C17).
- 2 8-mfd. electrolytic condensers (C18 and C19).
- 1 .0003-mfd. pre-set condenser (C23).
- 14 fixed resistances, 30,000 (R2), 25,000 (R1), 2000 (R5), 500,000 (R6), 20,000 (R8), 30,000 (R9), 1000 (R7), 250 (R12), 250 (R13), 50 (R15), 50 (R16), 10,000 (R10), 10,000 (R11), 200 (R3).
- 2 potentiometers, 2000 ohms. (R4), and 5000 ohms. (R14).

- 1 mains dropping resistance (R17).
- 1 snap H.F. choke.
- 1 L.F. choke H.T.11.
- 1 input push-pull transformer.
- 3 potentiometer brackets.
- 1 mains on-off switch.
- 5 valveholders—4 7-pin, 1 5-pin.
- 2 5-amp. mains fuses.
- 1 mains lead and plug.
- 5 valves : H.F. pen, detector, 2 pentodes. and 1 rectifier.
- 1 loud-speaker.
- 1 metal-covered wooden chassis.
- A.E. strip and plugs.
- 1 cabinet

Circuit No. 38.—This amplifier is called “Universal,” as it is so wired that it may be connected to any existing receiver,

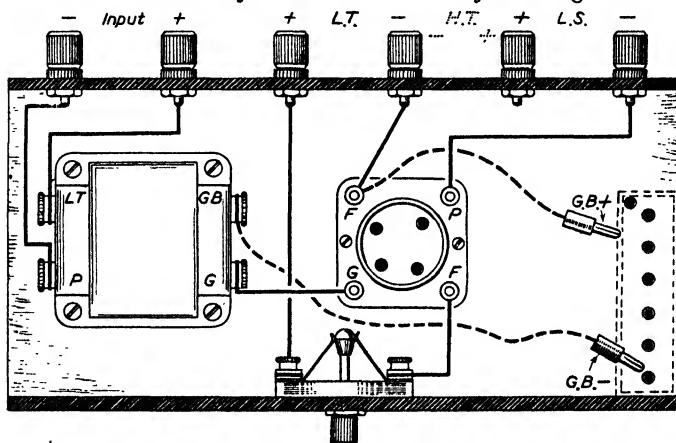

FIG. 87.—A One-valve Amplifier, Circuit No. 38.

whether crystal or valve. A glance at the wiring diagram (Fig. 87) will show that no terminal has been provided for the H.T. negative lead, and also that a grid bias battery is supplied for the amplifier. These two facts are easily explained, however. In any valve receiver the H.T.— wire is connected to one or other of the L.T. terminals, and, therefore, when the two L.T. terminals on this amplifier are joined to the corresponding terminals on the receiver with which the amplifier is used, the H.T.— lead is automatically joined in circuit. The existing receiver may employ a grid battery, but in this case there is not the slightest objection to having

a separate battery for the amplifier, especially as a valve will be needed in this case taking a higher value of bias, and then two of the 9-volt batteries may be joined in series, and the higher value of bias obtained in this way.

The above remarks apply, of course, only to the use of the amplifier with a valve set. In the case of a crystal receiver being used, the H.T.—lead is joined to the L.T.—terminal, and in addition a lead is taken from this terminal to earth. Having explained the design of the amplifier, we will now deal with its construction, which is of the very simplest, and should cause no trouble even to the very youngest novice.

Components required.—The only components are a transformer, valve-holder, switch, terminal strip and terminals, wire for wiring-up, grid bias leads, and wander plugs. The ratio of the transformer will depend on the use to which the amplifier is put. If added to a crystal set, the transformer should have a ratio of 7 to 1. If used after a single detector valve, the ratio may be 5 to 1; whilst if added to a receiver employing two or more valves, then the ratio should not be more than 3 to 1.

The Panel.—The panel of the amplifier may be constructed from 3-ply or any other wood, although if you wish to match your present set you may employ ebonite. This is an unnecessary expense, however. In the centre of the panel mount on the on-and-off switch. The transformer and valve-holder are screwed down to the baseboard as shown in the wiring diagram, leaving sufficient space at the right-hand side for two grid bias batteries side by side. The terminal strip with the six terminals fitted is then screwed to the rear of the baseboard. Use Glazite or some similar wire for wiring-up, and take care that the two leads to the primary of the transformer (that is, those lettered P. and H.T.) are connected to the input terminals so that when these latter are connected to the 'phone terminals of your present set, they will be in the correct direction. For this reason it is preferable to use the type of terminals which have engraved lettering so that no mistake can occur. The rest of the wiring is quite straightforward. The input terminals are then joined to the 'phone or L.S. terminals of your present receiver, and if this is a valve set, two insulated leads should then be joined from the two L.T. terminals on the amplifier to the corresponding terminals on the set. A separate flexible lead is joined from the L.S.+ terminal on the amplifier to an appropriate tapping on the H.T. battery. If added to

a crystal set, a separate lead should also be joined to the L.T.— terminal, and this lead should be plugged into the H.T.— tapping. Adjust the grid bias tapping according to the H.T. value and the valve-makers' instructions, and if only one valve or a crystal is employed in front of the amplifier a valve of the L.F. type should be used. If added to a multi-valve set, the valve should be of the small power type.

A few words of warning.—If your present set also has an on-and-off switch, don't forget to operate the switch on the amplifier as well when switching off, or the valve will be left burning, perhaps all night.

LIST OF COMPONENTS FOR CIRCUIT NO. 38

- 1 L.F. transformer.
- 1 valve-holder.
- 1 on-and-off switch.
- 6 terminals.
- Ebonite strip.
- Wire for connections, screws, wander plugs, etc.

Circuit No. 39.—Fig. 88 is a very ambitious two-valver. wherein the utmost has been obtained from two valves.

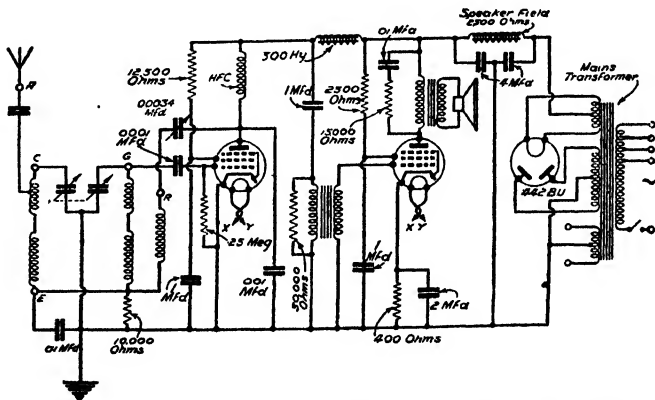

FIG. 88.—Theoretical Circuit of Mains-Operated Two-Pentode Two-Valver, Circuit No. 39.

The first is a special high-frequency pentode, and the output valve is a high-efficiency L.F. pentode. The circuit must be carefully constructed, and the special values must be adhered

to as the valves are worked at their maximum points. There is very little wiring to be carried out, but in view of the high voltages it should be done carefully. The special band-pass tuner may take any form, but it is essential that this type of tuned circuit is used, otherwise there will be difficulty in separating powerful stations in view of the high efficiency of the first valve stage. This receiver lends itself remarkably well to the design of a self-contained receiver, the mains section and loud-speaker occupying a position in the upper half of the cabinet, and the receiver proper taking up a position in the lower section. Special small Consolette cabinets may be obtained suitable for this type of set. It is not desirable to use a gramophone pick-up with this particular circuit.

LIST OF COMPONENTS FOR CIRCUIT NO. 39

- 1 band-pass filter.
- 1 2-gang condenser, .0005.
- 1 L.F. transformer.
- 1 .0003 reaction condenser.
- 1 standard H.F. choke.
- 1 Varley 300 henry L.F. choke.
- 1 .0001 fixed condenser.
- 1 .001 fixed condenser.
- 2 .01 fixed condensers.
- 3 1-mfd. fixed condensers.
- 1 2-mfd. fixed condenser.
- 2 4-mfd. fixed condensers.
- 2 5-pin valve-holders.
- 1 4-pin valve-holder.
- 1 $\frac{1}{4}$ -megohm 1-watt type resistance.
- 1 12,500-ohm 1-watt type resistance.
- 1 400-ohm 1-watt type resistance.
- 1 2500-ohm 1-watt type resistance.
- 1 30,000-ohm 1-watt type resistance.
- 1 10,000-ohm 1-watt type resistance.
- 1 15,000-ohm 1-watt type resistance.
- 1 Heayberd mains transformer (Model "A.C. Twin").
- 1 Gramplan energised speaker, Type E.I.

- 1 mains Toggle switch.
- 1 small mains connector.
- 1 terminal strip.
- 2 wander plugs (1 black and 1 red).
- 1 Cossor 442 B.U. rectifying valve.
- 1 Cossor MS-PEN-A (H.F. pentode valve).
- 1 Cossor MP-PEN (pentode output valve).
- 1 coil insulated wire, 3 yards red and black flex. screws, bulb for panel light, etc.

Circuit No. 40.—Although only a two-valver, Fig. 89 will prove a really good little receiver for the listener who does not want every station in the world, and who is satisfied with volume sufficient for domestic use, and does not wish to entertain the neighbours. When built as a complete radio-gram, it is possible to reproduce gramophone records at quite a respectable volume—comparable with a good acoustic gramophone. The circuit is extremely straightforward, and there are no points of interest or difficulty. A special gramophone cabinet will be required if the use of the gramophone is desired, and the circuit incorporates tone control for the reduction of needle scratch, etc. The valves are biased automatically, and the special tuning coil which is used will provide adequate selectivity for normal requirements.

LIST OF COMPONENTS FOR CIRCUIT NO. 40

- 1 Colvern T.D. coil.
- 1 polished plywood panel, 10 in. × 7 in.
- 1 5-ply baseboard, 15 in. × 14½ in.
- 1 .0005-mfd. condenser with disc drive.
- 1 3-point wavechange switch.
- 1 changeover (radiogram) switch.
- 1 20,000-ohm volume control with combined mains switch.
- 2 5-pin valve-holders.
- 1 coil.
- 2 .0001-mfd. fixed condensers.
- 1 .0005-mfd. fixed condenser.
- 1 1-megohm grid leak.

124 PRACTICAL WIRELESS CIRCUITS

- 1 grid-leak holder.
- 1 screened H.F. choke.
- 1 L.F. transformer.
- 1 Tone Compensator.
- 3 terminal mounts.
- 6 terminals, 2 marked "Pick-Up," and 1 each marked "A," "E," L.S.+, L.S.-.
- 1 mains transformer, giving outputs of 135 volts, 70 mA. and 2-0-2 volts, 4 amps.

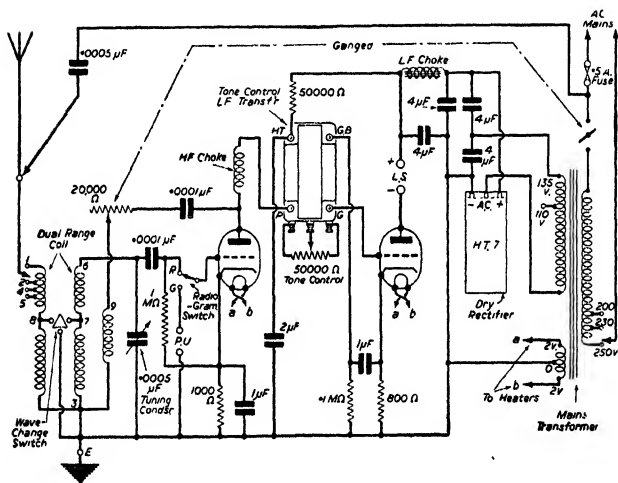

FIG. 89.—Circuit Diagram of the Two-valve A.C. Radio-gram (Circuit No. 40).

- | | |
|---|---|
| 1 smoothing choke. | 1 1000-ohm, 1-watt resistance. |
| 1 Westinghouse, Style H.T.7 metal rectifier. | 1 800-ohm, 1-watt resistance. |
| 4 4-mfd. condensers (400-volts D.C. working). | 2 coils Glazite, screws, short length flex. |
| 2 2-mfd. condenser (400-volts D.C. working). | 1 Mazda A.C.2 H.L. valve metalised. |
| 2 1-mfd. condensers (400 volts D.C. working). | 1 Mazda A.C.P. valve. |
| 1 fuse-holder with .5-amp. fuse. | 1 Electrical turntable. |
| 1 100,000-ohm, 1-watt resistance. | 1 On-Off switch (Q.M.B.). |
| 1 50,000-ohm, 1-watt resistance. | 1 pick-up. |
| | 1 Radio-gram cabinet. |

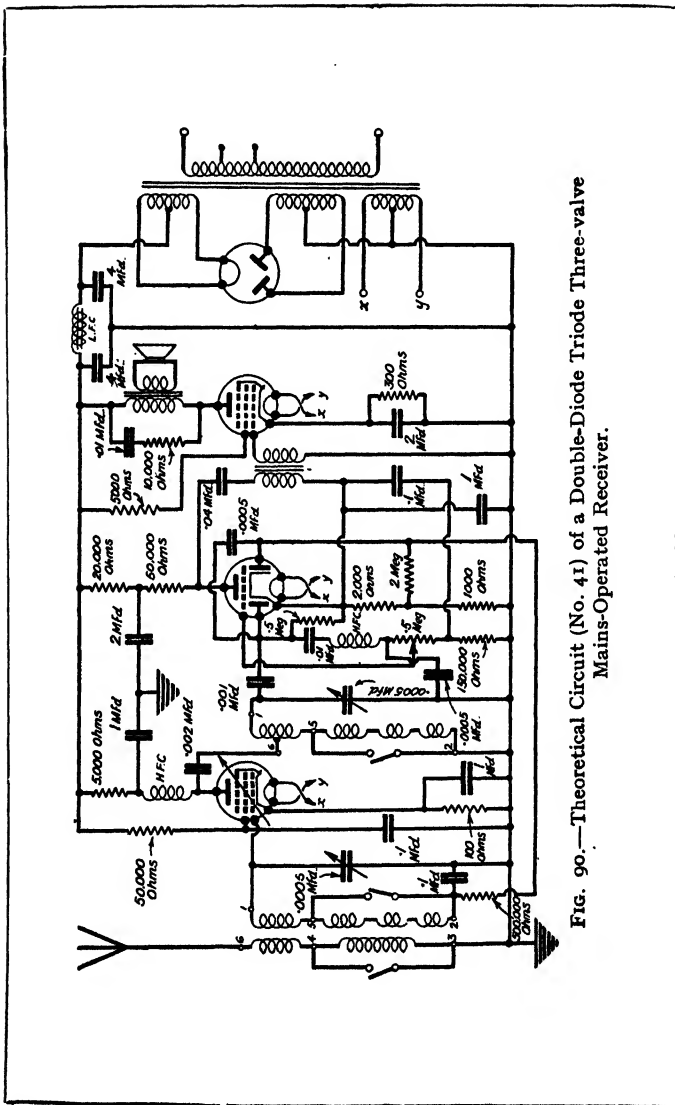

Fig. 90.—Theoretical Circuit (No. 41) of a Double-Diode Triode Three-valve Mains-Operated Receiver.

Circuit No. 41.—Fig. 90 is a very satisfactory circuit, giving the results generally obtained with four or five valves. The first valve is a variable- μ H.F. pentode, and the second is a special valve known as a Double-Diode-Triode. This provides rectification, automatic volume-control for the first valve, and L.F. amplification. The output valve is a pentode. Operated from the A.C. mains this is a circuit which requires great care in construction, and the values of the various resistances must be carefully adhered to. In certain cases a little latitude is permitted—but, in general, no alteration should be undertaken. It is rather difficult to incorporate a gramophone pick-up in the diode circuit, and therefore this should not be attempted. This circuit should not be attempted by the beginner as there is every likelihood of confusion due to the large number of resistances which are employed.

LIST OF COMPONENTS FOR CIRCUIT NO. 41

- 1 2-gang .0005-mfd. variable condenser.
- 1 pair coils.
- 1 H.F. choke.
- 1 H.F. choke.
- 1 L.F. transformer.
- 1 mains transformer.
- 13 resistances (1 each 100, 300, 1000, 2000, 10,000, 20,000, 150,000, and 2 each 5000, 50,000, and 500,000 ohms).
- 1 2-megohm grid leak.
- 3 .1-mfd. fixed condensers.
- 3 1-mfd. fixed condensers.
- 2 2-mfd. fixed condensers
- 2 4-mfd. electrolytic condensers.
- 1 .002 fixed condenser.
- 1 .001 fixed condenser.
- 2 .0005 fixed condensers.
- 1 .04 fixed condenser.
- 2 .01 fixed condensers.
- 2 5-pin chassis-mounting valve- holders. }
- 1 7-pin chassis-mounting valve-holder. } Clix.
- 1 4-pin chassis-mounting valve-holder. }

T.C.C.

Clix.

- 2 terminal mounts.
- 4 Belling-Lee Type B. terminals—**aerial, earth,**
L.S. +, and L.S. -.
- 1 .5-megohm volume control.
- 1 mains smoothing choke.
- 1 Ferranti VPT.4 valve.
- 1 Ferranti H.4D. valve.
- 1 Mazda A.C.-Pen valve.
- 1 Mazda UU2 valve.
- 1 sheet aluminium.
- 1 Bulgin On-Off Toggle switch, Type S.8o.
- 2 coils insulated wire, flex, bayonet plug, etc.

UNITS, ADAPTORS, AND AMPLIFIERS

Circuit No. 42.—As mentioned in various parts of this book, the band-pass tuner gives greater selectivity than the

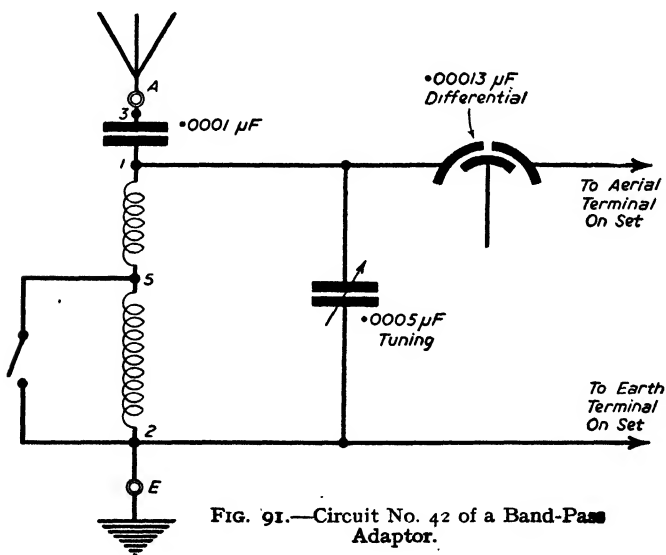

FIG. 91.—Circuit No. 42 of a Band-Pass Adaptor.

single circuit and is, in fact, essential for receivers which are situated close to a powerful transmitter. A single circuit tuner may be converted to a band-pass tuner by the addition of the unit illustrated in Fig. 91. It will be seen that very few parts are needed, and the conversion should not take long. In order to prevent interaction between the coil in the additional unit and the coil in the receiver it is worth while to build this adaptor in a metal (or metallised) box. Alternatively, the adaptor may be built in a wooden box, and the side nearest the present receiver may be covered with metal foil, and connected to earth to act as a screen. The differential condenser should be adjusted to give the required degree of selectivity, and this condenser must be adjusted in conjunction with the variable in the present receiver.

LIST OF COMPONENTS FOR CIRCUIT NO. 42

- 1 plywood panel, 8 in. × 6 in.
 - 1 baseboard, 8 in. × 6 in. × $\frac{1}{8}$ in.
 - 1 terminal mount (Belling-Lee).
 - 2 terminals, marked "A" and "E."
 - 2 spade terminals.
 - 1 dual range tuner.
 - 1 .0005-mfd. variable condenser.
 - 1 dial pointer.
 - 1 .00013-mfd. differential condenser.
- Short length insulated wire and a foot of twin flex.

Circuit No. 43.—Fig. 92 shows an adaptor for converting an existing broadcast receiver to Class B working. The input terminals are connected to the loud-speaker terminals on the present receiver, and a small power valve employed in the last socket of that receiver. The loud-speaker is then connected to the output terminals of this adaptor, and the receiver then delivers about 2 watts undistorted. No grid bias adjustments have to be made, and therefore the quality is of a very high order and justifies the use of a good moving-coil speaker. The components should be mounted on a small baseboard, and the whole built into a small cabinet with the valve totally enclosed. Input leads and output leads may be employed instead of terminals, and the unit

then becomes a very neat coupling between the present receiver and the loud-speaker.

LIST OF COMPONENTS FOR CIRCUIT NO. 43

- 1 driver transformer.
- 1 Class B output transformer.
- 1 On-Off switch S.38.
- 1 7-pin valve-holder (baseboard type).
- 1 Cossor 240 B. valve.

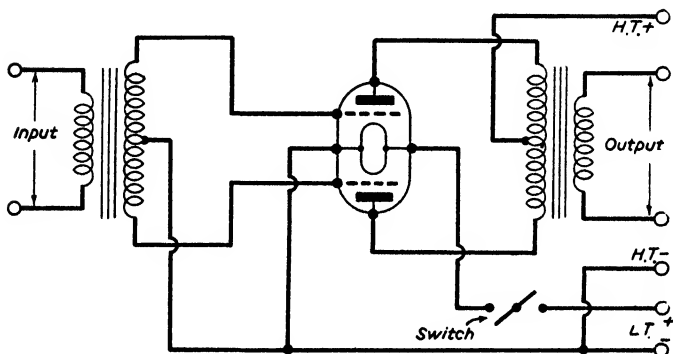

FIG. 92.—Theoretical Circuit No. 43 of the Class B Unit.

- 4 terminals—Input—, Input+, Output, Output.
- 2 terminal mounts.
- 1 battery cord—H.T.+, H.T.-, L.T.+, L.T.-.
- 1 baseboard, 9 in. × 5 in.
- 1 panel, 9 in. × 5 in.

Circuit No. 44.—This is another amplifier (Fig. 93), for adding to an existing receiver, this time employing a pentode valve. This delivers much greater volume than a triode valve, but has the disadvantage that it will not handle a very great input. Its principal application is, therefore, following a simple detector or one L.F. receiver. The amplifier is fitted with a tone control which should preferably be mounted on the panel so that the tone may be adjusted to suit the particular musical item which is being received.

The L.F. transformer should preferably be of fairly high ratio, especially when it follows a detector valve.

LIST OF COMPONENTS FOR CIRCUIT NO. 44

- 1 panel, 10 in. × 7 in.
- 1 baseboard, 10 in. × 7 in.
- 1 valve-holder.
- 1 L.F. transformer.
- 1 pentode output transformer.
- 1 2-mfd. fixed condenser.

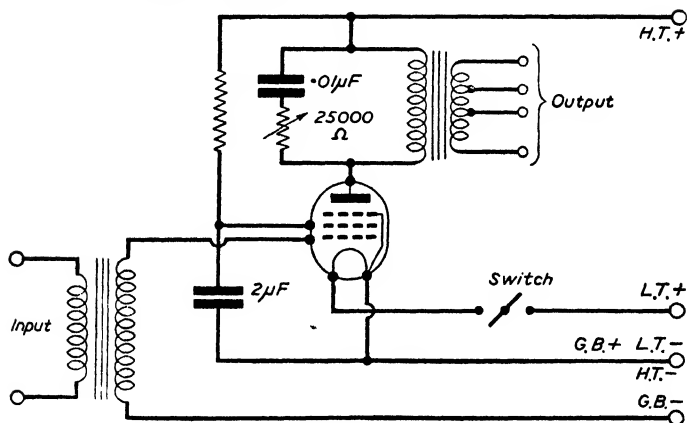

FIG. 93.—The Theoretical Circuit No. 44 of a Pentode Amplifier Unit.

- 1 0.01-mfd. fixed condenser.
- 1 pentode safety decoupling resistance.
- 1 volume control, 25,000 ohms.
- 1 On-and-Off switch.
- 7 terminals—Input, Output, G.B.—, G.B.+, L.T.—, L.T.+, H.T.+.
- 1 strip of ebonite, 10 in. × 1½ in., wire, screws, grid-bias battery, etc.

Circuit No. 45.—The variable-mu valve gives a great increase in range to a receiver of the detector L.F. type, and at the same time enables a very fine variation in volume to be obtained. When situated close to a powerful station

the H.F. valve is overloaded, but the variable- μ valve may be adjusted to suit this condition, by varying the bias applied to the valve. In this way the volume may be controlled from maximum to minimum and no distortion due to overloading takes place. The H.F. unit illustrated in Fig. 94 may be built up for addition to any simple

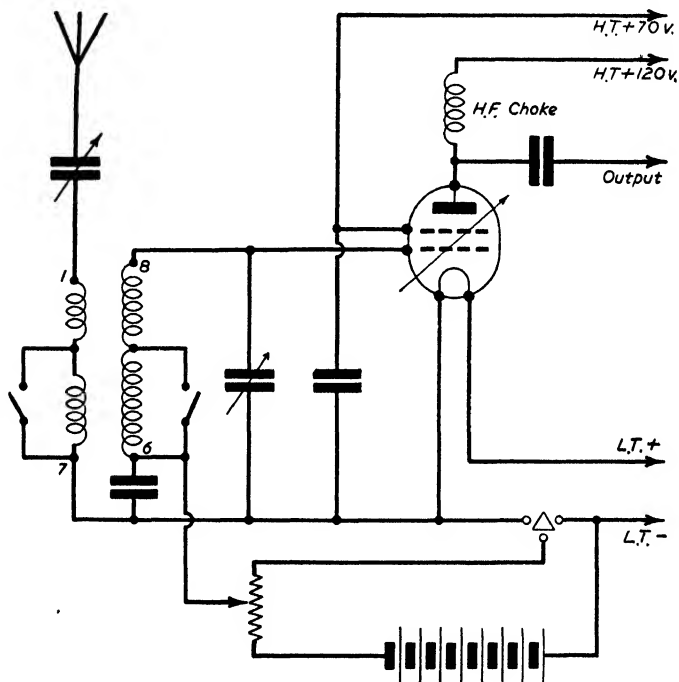

FIG. 94.—Circuit (No. 45) of an H.F. Unit.

set and will enormously improve it, both from the point of view of station-getting and controllability. The coil is rather critical, but the remaining components may be of any suitable type. In order to prevent instability, it is preferable to enclose the unit in a small cabinet of metal, or use a wooden box and line it with foil connected to earth. Of course, great care should be taken to avoid short-circuits

LIST OF COMPONENTS FOR CIRCUIT NO. 45

- 1 screened coil with switch, Telsen No. 216.
- 1 small friction disc drive.
- 1 wire-wound potentiometer, 50,000 ohms.
 - 1 screened H.F. choke with shielded pigtail.
 - 2 1·0-mfd. condensers
 - 1 0·0002-mfd. condenser.
 - 1 0·0005-mfd. direct drive variable condenser.
 - 1 0·0003 (max.) pre-set condenser.
 - 1 3-point on-off switch.
 - 1 4-pin valve-holder.
 - 1 220 V.S.G. valve, Cossor (metallised).
 - 1 9-volt grid bias battery.

Circuit No. 46.—This enables a battery receiver to be worked from A.C. mains without alteration to the wiring (4-volt mains valves will be required) (Fig. 95). It provides three separate positive tappings, one of which is variable and especially designed for supplying the screening grid of an H.F. stage or the detector stage. Although only half-wave rectification is employed, the smoothing is quite adequate, and no hum should be experienced. To be on the safe side, the complete unit should be enclosed in a metal cabinet, and the components well insulated. An earthing terminal should be fitted to this case and connected to earth. No shocks can therefore arise. Care should be taken that the condensers, etc., are of the right type, as shown in the undermentioned list of parts.

LIST OF COMPONENTS FOR CIRCUIT NO. 46

- 1 plywood panel, 8 in. × 6 in.
- 1 baseboard, 8 in. × 12 in. × $\frac{1}{8}$ in.
- 1 mains transformer supplying 200 volts at 30 mA. and 4 volts at 4 amps.
- 1 40-henry smoothing choke.
- 1 style H T.7 metal rectifier.
- 2 4-mfd. condensers, for 400-volt working.
- 2 2-mfd. condensers, for 400-volt working.
- 1 baseboard fuse-holder with 60 mA. fuse.

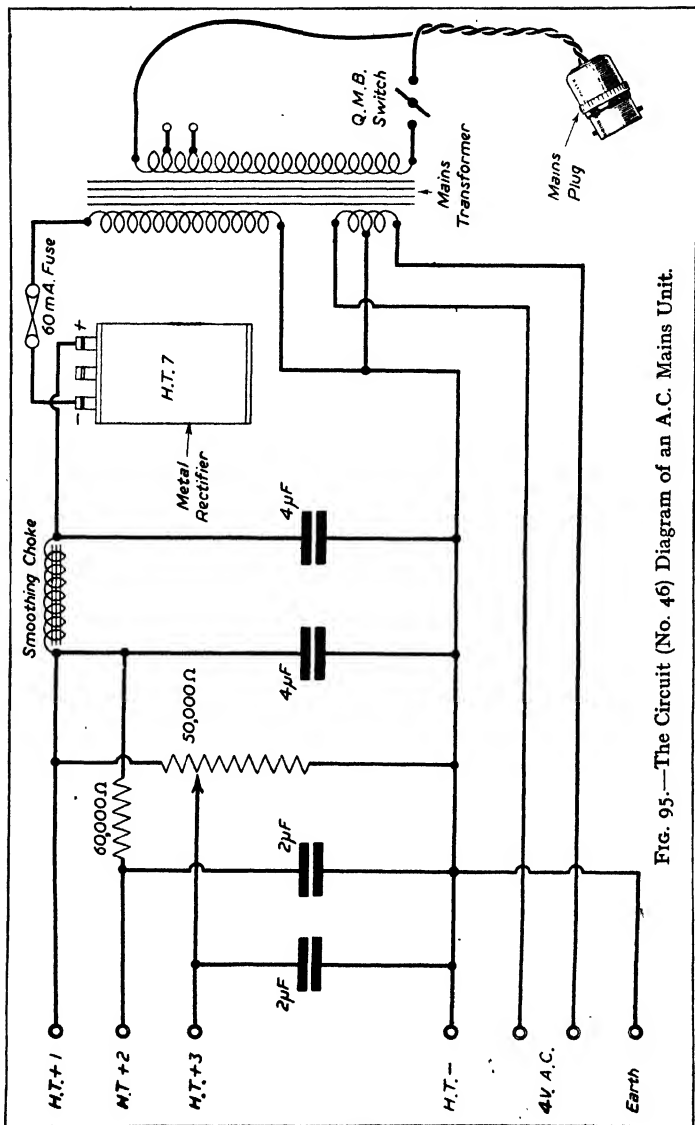

FIG. 95.—The Circuit (No. 46) Diagram of an A.C. Mains Unit.

134 PRACTICAL WIRELESS CIRCUITS

- 1 60,000-ohm metallised resistance (1 watt).
- 1 50,000-ohm potentiometer.
- 1 Q.M.B. mains switch.
- 3 terminals—2 marked "L.T.A.C." and 1 "Earth."
- 3 terminal insulating washers.
- 4 plugs and sockets, marked H.T.—, H.T.1, H.T.2, and H.T.3.
- 1 mains plug to suit convenient socket.
- 1 coil insulated wire, short length twin-braided screened wire, length flex, screws, etc.

Circuit No. 47.—To avoid the expense of continually renewing the high-tension battery a mains unit may be

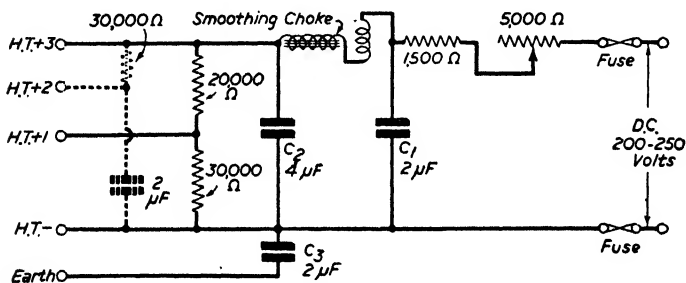

FIG. 96.—The Theoretical Circuit No. 47 of a D.C. Mains Unit.

employed where the electric light mains are laid on. In the case of D.C. mains the apparatus is of the very simplest, and the circuit (Fig. 96) shows the parts which are necessary to make up a really neat unit. This should, for safety, be enclosed in a metal box, and the metal fitted with a terminal connected to earth. The utmost care should be exercised to see that the components and wiring do not come into contact with the metal box. The variable resistance should be adjusted to give the required output voltage, and the earth terminal on the receiver should be joined to the H.T.— terminal and *not* to earth. Alternatively, a 2-mfd. fixed condenser should be connected to the earth terminal on the set, and the remaining terminal on the condenser joined to earth. In this way you will reduce the possibility of shocks. A further safeguard consists of including a small condenser in series with the aerial.

LIST OF COMPONENTS FOR CIRCUIT NO. 47

- 1 potentiometer, 5000 ohm.
- 2 1-watt Type resistors, 20,000 and 20,000 ohm.
- 1 2-watt Type resistor, 1,500 ohm.
- 4 plugs and sockets.
- Insulated connecting wire.
- Ebonite panel, $4\frac{1}{2}$ in. \times $3\frac{1}{2}$ in. \times $\frac{1}{2}$ in.
- Baseboard, $8\frac{1}{2}$ in. \times $4\frac{1}{2}$ in. \times $\frac{3}{8}$ in.
- 1 choke (25 henries, 50 mA.).
- 2 4-mfd. condenser, Type 80-81.
- 2 2-mfd. condensers, 750 volt test.

Circuit No. 48.—As all the best gramophone records are electrically recorded, it is only appropriate that the reproduction of sound should also be of an electrical nature.

The Pick-up.—Electrical reproduction is carried out with the help of the gramophone pick-up. In such a pick-up the needle is attached to a small armature which is capable of vibrating between pole pieces of a permanent magnet. Around the armature or the magnet there is a small coil in which electrical impulses are induced owing to the change in the magnetic field caused by the vibrating armature. In this manner each sideways vibration results in an electrical impulse, so that there is a group of such impulses corresponding to each sound. You will realise that the electrical currents generated in the pick-up coil are of a very minute character and have to be amplified. This is done with the help of a low-frequency amplifier such as is described on page 136. The recommended amplifier has two valves, as may be seen from the theoretical diagram shown in Fig. 97. The two wires from the pick-up terminals (the latter are connected to the pick-up coil) are connected across the grid and the filament of the first valve. You will notice that a grid bias is applied to the grid through the pick-up.

The Connections.—The filaments of the two valves are connected in parallel across the L.T. supply, a common filament regulator controlling the voltage across the filaments. The anode of the first valve is connected to one side of the primary of an L.F. transformer, the other side of the primary going to the positive side of the H.T. battery. The secondary

of the transformer is connected to the grid of the second valve on one side, while its other side is given a grid bias in the usual way. The anode of the second valve is connected to the positive side of the H.T. battery through the loud-speaker. You will find that a detector valve in the first stage and a power valve in the second stage will do the trick. Make sure that you use a good quality transformer. A cheap transformer will cause a good deal of distortion. As you will see from the circuit diagram (Fig 97), it is exceedingly simple and can be built up in a couple of hours, including the panel

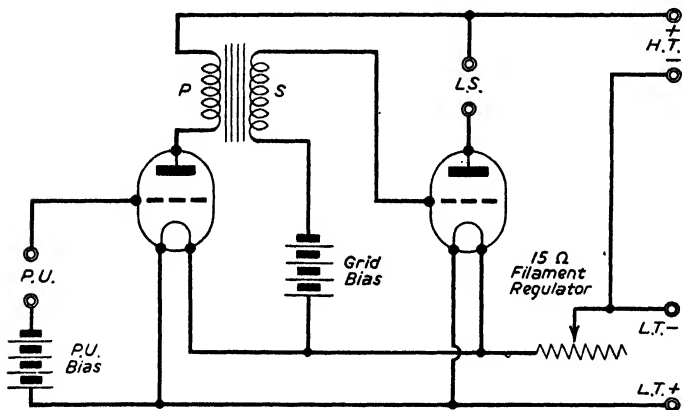

FIG. 97.—Circuit No. 48 Diagram for a Two-valve Gramophone Amplifier.

drilling and the assembling. Fig. 98 shows how to connect the gramophone amplifier to the set. The following components are required :

LIST OF COMPONENTS FOR CIRCUIT NO. 48

- 1 15-ohm filament regulator.
- 1 detector valve.
- 1 L.F. or power valve.
- 2 9-volt dry grid bias batteries.
- 1 4-volt accumulator.
- 1 150-volt H.T. battery.
- 1 ebonite panel, $9\frac{1}{2}$ in. wide, 4 in. high, and $\frac{1}{8}$ in. thick.
- 1 wooden baseboard, $9\frac{1}{2}$ in. \times $8\frac{1}{2}$ in.

- 1 ebonite terminal strip, $9\frac{1}{2}$ in. \times 1 in. \times $\frac{1}{2}$ in
- 7 terminals, screws, wood screws, and wire.
- 2 metal brackets.
- 1 gramophone pick-up.
- 2 valve-holders.
- 1 L.F. transformer.

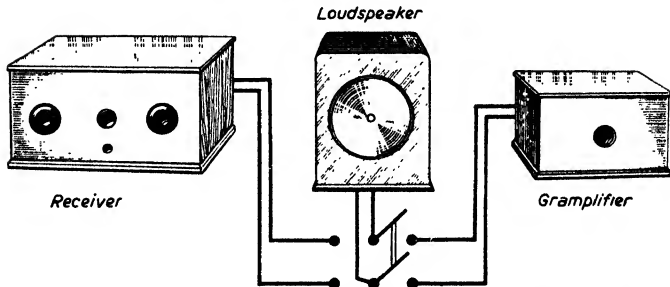

FIG. 98.—How the Gramophone Amplifying Apparatus is connected.

CIRCUITS Nos. 49 to 60

Circuit No. 49.—The simplest type of amplifier for what might be called “universal” use is that shown in Fig. 99. This is battery operated, employs a pentode valve, and can be fed equally well from a small battery receiver, pick-up or microphone unit without alteration. It will be seen that there are very few components required, and that they are mounted on a small wooden baseboard. The parts used are: one baseboard measuring 6 inches by 8 inches; one W.B. 5-pin baseboard-mounting valve holder; four Belling Lee twin-terminal mounts; seven terminals, two marked input, two marked P.U., two marked L.S., and one marked Earth; one T.C.C. or -mfd. fixed condenser (type 40); one .25 megohm Dubilier, 1-watt grid leak; one Varley D.P. 24 low-frequency choke; one pair Bulgin G.B. battery clips; one Bulgin push-pull on-off switch; one component bracket; one Cossor pentode valve, 220 H.P.T. or 220 P.T. (see later note); flex and wander plugs.

The positions of the few components can clearly be seen in Fig. 99, and no difficulty should be experienced in mounting them and wiring up according to the illustration. It should

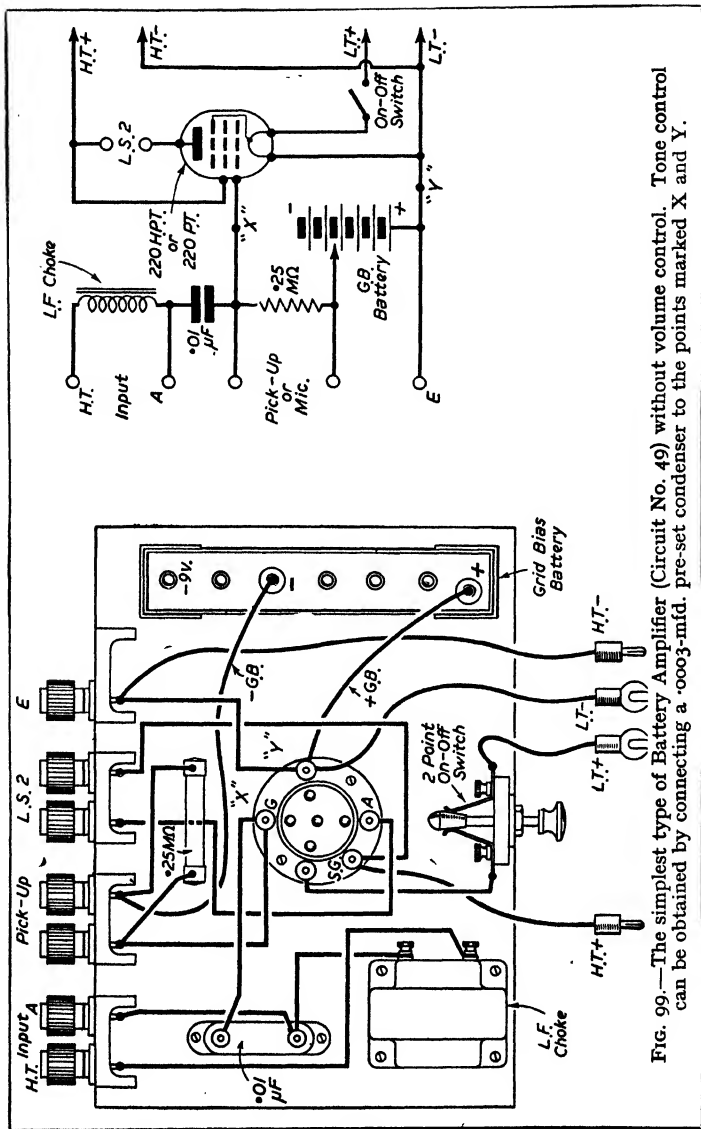

FIG. 99.—The simplest type of Battery Amplifier (Circuit No. 49) without volume control. Tone control can be obtained by connecting a .0003-mfd. pre-set condenser to the points marked X and Y.

be noticed that only one terminal is fitted to one of the terminal mounts, this being for an earth connection. When the amplifier is required to operate directly from a pick-up or from a microphone—provided with its own input transformer and battery, of course—a 220 H.P.T. valve is to be preferred, because this has a high amplification factor and will permit of fairly good loud-speaker results. The same valve is also suitable when the unit is to be used, after a receiver which is not fitted with an L.F. stage or which gives an output which is insufficient, for the satisfactory operation of a loud-speaker. On the other hand, if the output from the receiver is fairly good, the 200 P.T. valve should be used, because this gives less amplification, but is able to handle a larger input. It should be made quite clear, however, that the amplifier is not suitable for use after a set with a pentode output valve, or which already provides good speaker-strength reception. It could be used in the latter case only by replacing the pentode by a super-power valve such as the Cossor 230 X.P.

The correct grid-bias voltage should, of course, be chosen according to the valve employed, and is -4.5 volts for the H.P.T., -7.5 volts for the P.T., or -15 volts for the P.X., assuming in every case the use of 120 volts high-tension. The latter can be supplied by an H.T. battery, but an eliminator or super-capacity battery is very desirable when using the super-power valve.

In order to use the amplifier with a receiver, the two terminals marked Input should be connected in place of the 'phones or speaker, connecting the terminal marked A in Fig. 98 to that terminal which is joined to the anode of the last valve in the set. If a pick-up or microphone is to be used, this component should be joined to the terminals marked P.U., when the other two terminals previously mentioned should be left disconnected. The terminal marked E should, for preference, be connected to an earth lead in every case when using a pick-up or microphone. The method of connecting the flexible leads is obvious, since they are attached to the battery terminals indicated.

When the amplifier is to be used with a receiver it will be desired to employ the same H.T. and L.T. supplies for both, and this can be done simply by connecting the flexible leads to the same batteries; in this case, however, the earth terminal should be left free, because an earth-return will be obtained automatically through the batteries.

Circuit No. 50.—A rather more advanced type of amplifier of very similar type is shown in Fig. 100, but

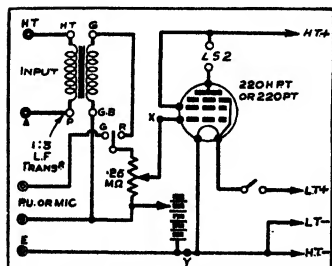
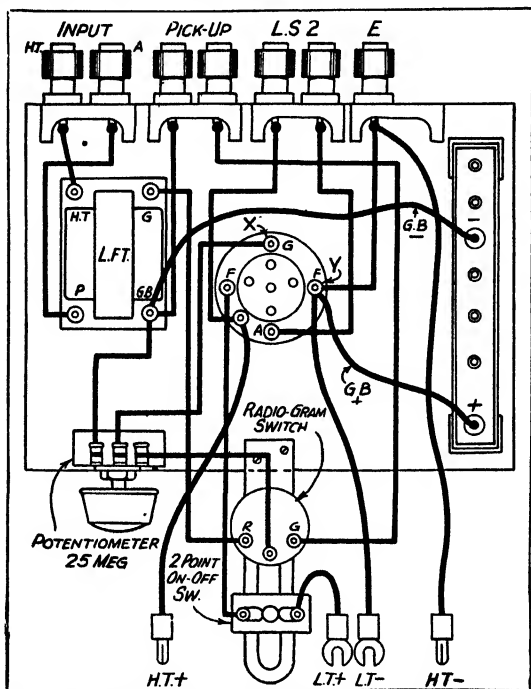

FIG. 100.—A simple Pentode Amplifier with radiogram switch and volume control (Circuit No. 50). Tone control can be effected, if desired, by connecting a .0003-mfd. preset condenser between the points marked X and Y.

here the L.F. choke is replaced by a 1:3 or 1:5 low-frequency transformer, such as the Ferranti type A.F., which actually has a ratio of 1:3.5. Additionally, the grid

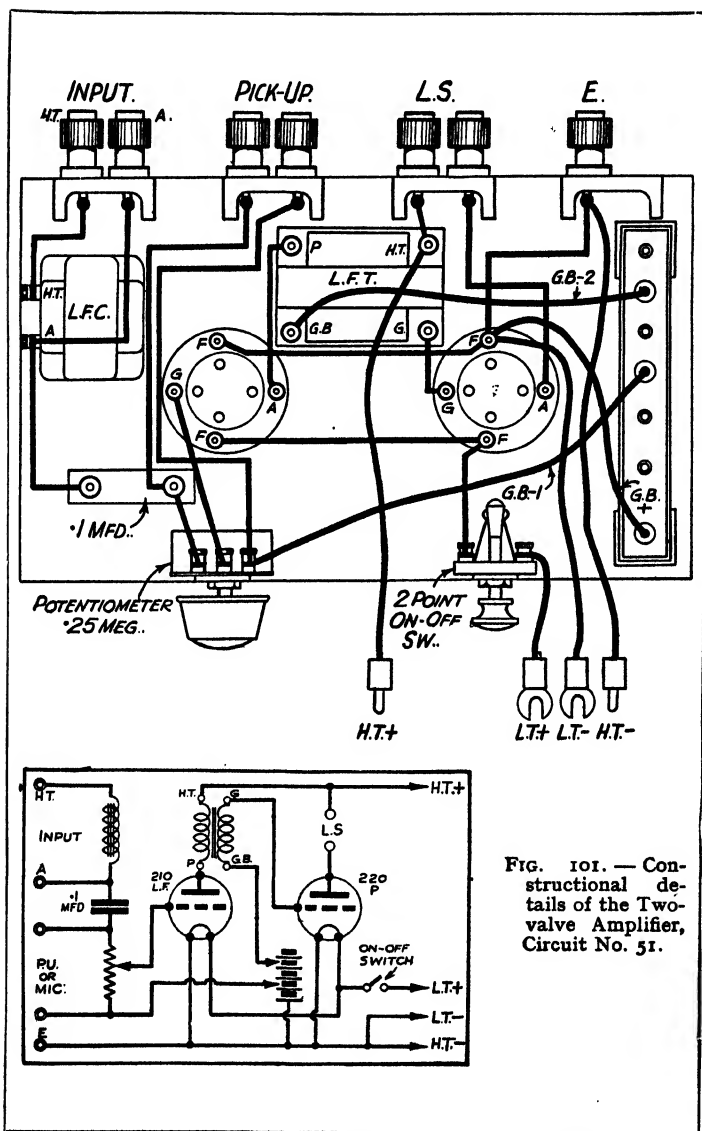

FIG. 101. — Constructional details of the Two-valve Amplifier, Circuit No. 51.

leak and condenser are replaced by a good quality .25-megohm potentiometer, which is mounted on a second component bracket. There is also a radio-gram change-over switch—the rotary Snap switch is suitable—and this is mounted on the same bracket as the on-off switch.

This amplifier is particularly suitable for use after a short-wave receiver or other set not fitted with a power or pentode output valve, and when the maximum degree of amplification is required. The method of connecting the unit is as described for the previous arrangement, although it will often be found that greater amplification on pick-up and microphone can be obtained by connecting the appropriate component to the terminals marked Input, leaving the actual pick-up terminals disconnected. By doing this the step-up ratio of the transformer is utilised, so that greater volume is obtained. This idea is especially useful when the pick-up or microphone employed is not of a very sensitive pattern.

When using a pentode valve in either of the circuits described, it might be found that reproduction is somewhat high pitched. The tone can be "mellowed," and a fair degree of tone control obtained by connecting a .0003-mfd. pre-set condenser between the points marked X and Y. The tone may then be lowered by increasing the capacity of this condenser.

Circuit No. 51.—Neither of the amplifiers described above will give a very high degree of amplification combined with good quality, and if the amplifier is being built particularly for use with a gramophone pick-up or microphone it will be better to use two valves in the arrangement shown in Fig. 101. This is a combination of the circuits of Figs. 99 and 100 with the addition of a second valve. The input circuit consists of an L.F. choke and .01-mfd. fixed condenser, and these feed into a Cossor 210 L.F. valve, which is in turn coupled to the output valve—Cossor 220 P.—through the Ferranti transformer, or a similar component of another make, used in the second circuit. Again the components are mounted on a flat wooden baseboard, but this time it measures approximately 10 inches by 6 inches. The correct G.B. voltages for the two valves, for 120 volts high-tension, are —3 volts for G.B. —1 and —6 volts for G.B. —2.

It should be noted in mounting the components that

the transformer and choke are placed fairly well apart, and that they are mounted with their cores at right-angles in order to prevent the possibility of low-frequency instability. The on-off switch is mounted on one component bracket, and the volume control is mounted on a second bracket of the same type.

It is rare that any difficulty is experienced in using and operating amplifiers of the simple types dealt with, but there are a few points which should be borne in mind if good quality is to be obtained, and if low-frequency oscillation is to be entirely avoided. The main point is that a good high-tension battery must be employed, and it is equally important that the accumulator should be well able to supply the current required. The latter point scarcely arises if the amplifier is being operated alone, but if used in conjunction with a receiver it should receive its full measure of attention. The reason is that if the accumulator used with the set was chosen so that its capacity was just sufficient for the original set it would be unable to supply the additional current needed without a voltage drop and, possibly, without damaging the battery. Should there be any doubt on this score it is well worth while to obtain a separate accumulator especially for the additional valves.

Another important point is that the pick-up or microphone leads should be properly screened, especially if they are more than a few feet in length, the screen being earth-connected. It is also important, in the case of a microphone, that this should be as far away from the loud-speaker as possible, or that it should be screened from it by means of a sheet of card or other non-resonant material. The reason for this is that if sound from the speaker should strike the diaphragm of the microphone a very unpleasant "ringing" or "booming" sound would be created, and there would be distortion.

No mention has been made of the loud-speaker to be used, but it is naturally important that this should be of suitable type. It is best to use one with a tapped transformer, so that it can be used equally well whether it is in the anode circuit of a pentode or triode valve. A speaker such as the "Stentorian" is eminently satisfactory, and any speaker from this range can be used with any of the three amplifiers described; the larger models are better for use with the super-power valve or when the greatest possible output is required but the smallest in the range

can be used with complete satisfaction with any of the three amplifiers.

Circuit No. 52.—The simplest possible type of mains-operated amplifier is that for use with D.C. mains, and a suitable circuit is given in Fig. 102, along with a wiring plan. The latter shows the use of a flat metallised baseboard, but a chassis could be used if preferred; it was thought, however, that the construction would be simplified by using the baseboard.

The arrangement is similar to one of those given for battery amplifiers, a single pentode valve being used with input arrangements suitable for either radio, microphone, or pick-up. It is for this reason that both choke-capacity, and direct coupling are indicated. One point which should be observed is that a fixed condenser is included in one pick-up lead as a safeguard against shocks. With some types of pick-up, however—piezo-electric types in particular—the condenser must be omitted, because it is necessary that there should be a complete electrical circuit through the pick-up and volume control. In such cases greater care must be taken in handling the apparatus, and the power supply should be switched off when connecting or disconnecting any piece of apparatus. This is a wise precaution even when the condenser is included, but is not absolutely essential.

The valve used is a Cossor 40 P.P.A., which has a heater consumption of .2 ampere at 40 volts, and which requires a total of about 40 m.a. at 150 anode volts, as well as a bias potential of approximately—25 volts. The mains voltage is dropped to the necessary figure for the heater by including in series a 240-volt, 60-watt lamp. This has a resistance of rather less than 1000-ohms, whilst the resistance of the valve heater is 200-ohms, so that the total resistance in circuit is about 1200-ohms. This means that when the voltage of the mains is, say, 240, the current flowing will be 240 divided by 1200, or 1-5 ampere, which is the correct figure. Actually, it is not essential that the current should be precisely this figure, and therefore the amplifier can be used on supply voltages of 230 to 250 volts quite safely. But even if the voltage were only 210, for example, the heater would be only slightly under-fed, and results would not suffer to any serious extent. In order to obtain maximum results with less than 220 volts, however,

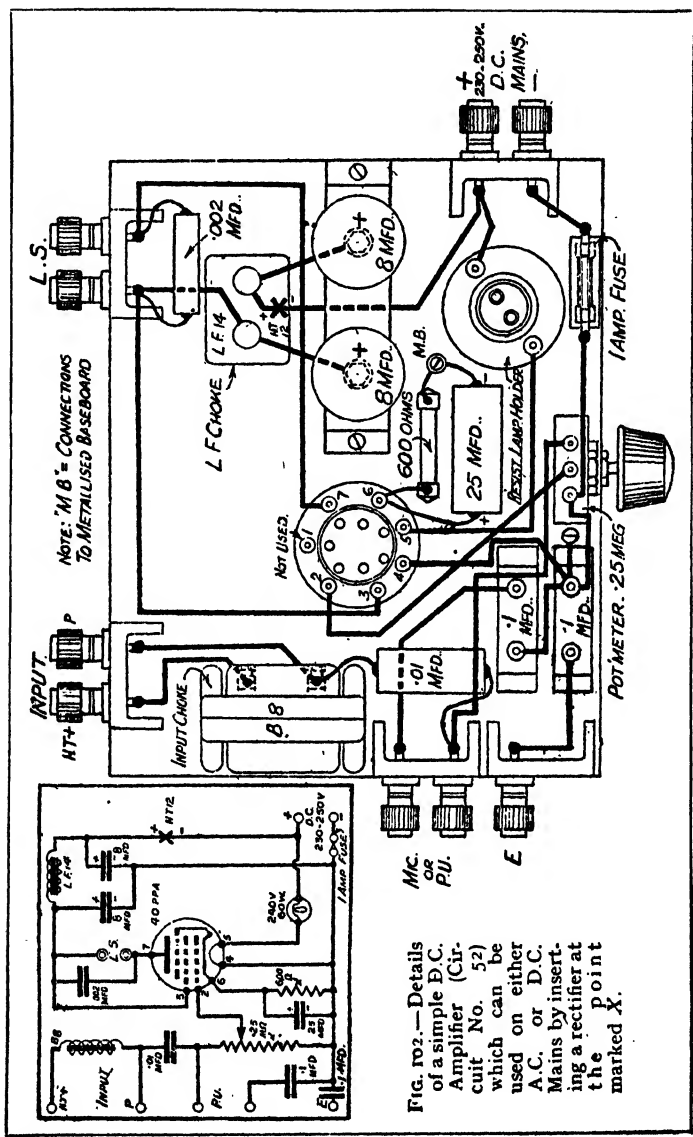

FIG. 102.—Details of a simple D.C. Amplifier (Circuit No. 52) which can be used on either A.C. or D.C. Mains by inserting a rectifier at the point marked X.

it would be desirable to use a lamp rated at 60 watts, 220 volts.

The high-tension supply is smoothed by means of the smoothing choke marked L.F. 14, this being the designation of a suitable Bulgin component. Additional smoothing is provided by the resistance of the lamp and by the two 8-mfd. electrolytic condensers shown. It is preferable that these condensers be of the "reversible" type, such as Dubilier type 0281, so that they will not be damaged should the mains leads be wrongly connected. The correct polarity is easily found by trial; if the amplifier does not function after being switched on for a minute, the mains leads should be reversed, or the plug reversed in its socket.

Grid bias is obtained by including a 600-ohm., 1-watt fixed resistance in series with the cathode lead, and this is by-passed by means of a 25-mfd., 50-volt tubular electrolytic condenser, of which there is a suitable component in either the T.C.C. or Dubilier range.

It is not necessary to give a complete list of components, since the main parts are similar to those used in the battery amplifiers previously described. A suitable choke for the input circuit is a Ferranti type B.8, which has an inductance of 25 henries when carrying 10 m.a. The holder for the electric lamp is of the ordinary batten type, and can be bought at any electrical store. It should be noted that a .002-mfd. fixed condenser is connected in parallel with the speaker terminals, this being to prevent over-accentuation of the high notes. This condenser should have a rated working voltage of not less than 500, but any make can be used. Should any constructors wish to make use of a smoothing choke which is on hand, it should be mentioned that the component suggested above has an inductance of 20 henries at 50 m.a. and a D.C. resistance of 400-ohms. This resistance, combined with that of the bias resistance and of the loud-speaker transformer reduces the anode voltage to just about 150, which is the maximum rating for the Cossor 40 P.P.A.

With regard to the constructional details, it should be explained that the layout is not very critical, although it is desirable that the two chokes should be mounted at opposite ends of the baseboard or chassis, with their axes at right-angles. When using a baseboard, the two 8-mfd. electrolytic condensers have to be mounted on a metal "bridge" so that their cases are earthed to the baseboard and con-

nection to the positive terminals can be made on the underside of the "bridge." If it is not wished to make the mounting bracket, two separate brackets can be bought ready made from many dealers. Other constructional details are obvious from Fig. 102

The amplifier can be used in conjunction with either a D.C. or battery set, and will provide a maximum output of more than 2 watts. It is recommended that it be fed from mains whose negative lead is earthed, in which case the terminal marked E can be joined either to a separate earth lead or to the earth terminal on the set. Where the positive mains are earthed, it can be used with a D.C. receiver by joining the E terminal to the negative line in the set, and in no circumstance should a direct earth connection be made to the amplifier. Microphone or pick-up can be used by following the general instructions given in the previous article.

It will be understood that the full output of the valve will be obtained only when the input is sufficiently high, for which reason the pick-up or microphone employed should be one of the most sensitive pattern. The amplifier can be used in conjunction with a receiver of which the output is not more than about 300 milliwatts, and of which the last valve does not pass more than a maximum of 15 m.a.

The speaker may be of the permanent-magnet type, but better results will be obtained by using a D.C. energised speaker, the field coil being connected directly to the positive and negative supply terminals.

Should the amplifier be required for either A.C. or D.C. operation at will, this can be provided quite easily by inserting a Westinghouse style H.T.12 metal rectifier at the point marked X, wiring the positive and negative terminals of this as indicated. The rectifier can be left in circuit whether the supply is D.C. or A.C., for it will simply act as a small resistance to D.C.

Circuit No. 53.—Details of an A.C. amplifier capable of providing a greater degree of amplification are given in Fig. 103, where it will be seen that two triode valves are used for amplification, with a full-wave rectifying valve for H.T. supply. The valves recommended are: Osram M.H. 41 for the first stage, Cossor 401 M.P. for the second, and Cossor 506 B.U. for rectifying. The input choke is the same as that used for the D.C. unit, and the L.F. transformer

should be a high-quality component such as the Varley D.P.3, which has a ratio of 1:5 and a primary current-carrying capacity of up to 20 m.a. The mains transformer may be a Wearite type T-21 A, whilst the mains switch should be of the Q.M.B. pattern.

In order to save the expense of a smoothing choke it is suggested that a 2500-ohm.-field energised moving-coil speaker should be used, since this will reduce the 270 volts supplied by the rectifier (at half load) to a suitable value for the valve anodes. The energising wattage will be on the low side—just over 2 watts—but this will provide results as good as those to be obtained when using permanent-magnet speakers of the less-sensitive type. When the highest possible output is required, however, the speaker field should be replaced by a Wearite H.T.14 smoothing choke, and a good permanent-magnet speaker, such as the "Stentorian." should be joined to the speaker terminals. The 8-mfd. electrolytic condensers should be rated at 500 volts peak working, and should be mounted on a "bridge" as described above.

A suitable method of arranging the components is shown in Fig. 103, but the parts shown are not intended to represent those of a particular maker, so the reader can make use of any that are on hand, provided that they have characteristics similar to those detailed above. Where new parts are to be bought it is advised that constructors use those of which the makes have been mentioned, for it is known that these are perfectly suitable.

Connections.—The mains amplifier can be used in the same manner as those previously described, but when used with a receiver it should follow the detector or second detector, because it is not intended for a high input. This does not mean that it could not be used with a set having an L.F. stage, but in that case the volume control would have to be set almost to its minimum, so that a good deal of amplification would be lost, and one of the valves would be "wasted." It has a maximum undistorted output of 1250 milliwatts, and is therefore unsuitable for public address work or anything of that nature, for which details of excellent amplifiers have previously been given in these pages.

It is worth mentioning in conclusion that, in any of the amplifiers described, the input choke and 0.01-mfd. coupling condenser may simply be omitted if microphone and pick-up

only are to be used, since these components are included purely for the purposes of "radio" and do not affect the pick-up connections in the slightest measure.

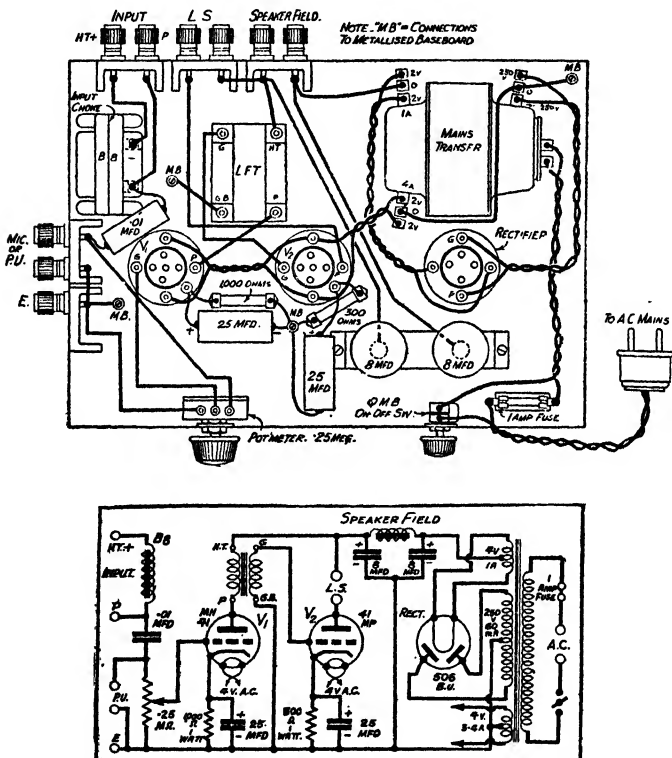

FIG. 103.—Layout for a simple and effective Two-valve A.C. Amplifier (Circuit No. 53).

Circuits 54 to 56.—The features of a high quality receiver from the musician's point of view are six in number : softness and purity ; spaciousness ; liveness ; fidelity ; clarity ; proportionality.

These six characteristics all apply to the performance emanating from the loud-speaker and not, of course, to the

electrical constituents of the receiver itself. These are the things that we should expect to *hear*, but most of us go on expecting instead of getting them. The first and third hardly require explaining: the second suggests sound radiation, the fourth means character likeness, the fifth a clear definition of all the parts that make up the whole, and the sixth a correct balance between bass, middle, and treble registers. It is well known that the third, fourth and fifth characteristics can be obtained reliably from resistance-capacity coupling, while the first and second can, in my opinion, be best secured from the special form of coupling to be described later. The last feature—proportionality or balance—depends on the shape which the frequency response curve is arranged to take. Since the majority of receivers are used in private houses and the volume level is normally below that of the original, it is essential to raise the response curve at the lower end of the spectrum, while the middle and upper portions should be as free from peaks and troughs as possible, in view of the fact that the loud-speaker characteristic is not innocent of these blemishes. Broadcasting conditions being what they are, there may be a distinct advantage in a slightly drooping response above 8000 cycles provided the droop is gradual, while the reproduction of gramophone records usually demands a gradient in the response curve above 6000 cycles at least.

The response curve of the amplifier is straight between 100 and 8000 cycles. Below 100 cycles the curve begins to rise till it reaches its maximum point at 50 cycles where the gain is eight decibels, and below 50 cycles it starts falling very slightly down to 25 cycles, the drop being of the order of one decibel, so that at 25 cycles the actual gain is seven decibels. Above 8000 cycles the response gradually drops till at 10,000 cycles there is a loss of 3.5 decibels, which is quite inconsiderable. The frequency characteristic, however, gives only a very imperfect idea of the performance of the amplifier, and it is only mentioned in order to satisfy the curiosity of those who are apt to place undue confidence in response curves.

It has already been pointed out that liveliness, fidelity, and clarity of reproduction may be satisfactorily obtained from the employment of resistance-capacity coupling. In accordance with this postulate the first two stages of the amplifier are so treated, and Fig. 104 gives the fundamental

circuit, with (in addition) a special form of high-note control incorporated in the grid circuit of the second valve. This treble control is designed to operate in conjunction with the quarter megohm potentiometer and will be found extremely serviceable in all circumstances. It is well known that as the volume of the receiver is reduced by means of the usual potentiometer control, high-note loss is introduced as the resistance between the coupling condenser and the slider is increased, and in order to compensate for this loss a condenser is shunted across these two points. After careful experiment it has been decided to use a capacity

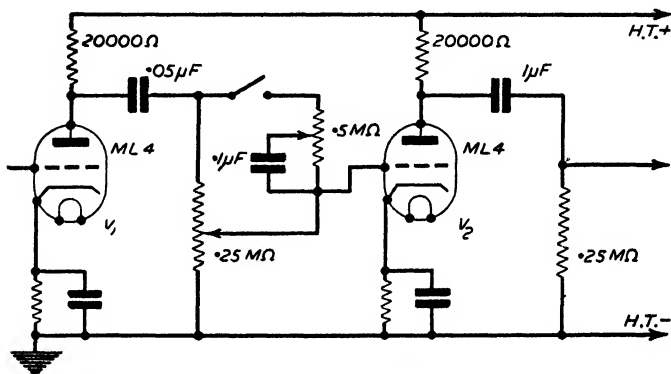

FIG. 104.—The first two stages of the Amplifier (Circuit No. 54) with the special high-note control.

of 0.1-mfd. for this condenser and to graduate the control by means of a half-megohm variable resistor. A switch is also incorporated, since even with half-megohm resistance fully in circuit the condenser still affects the quality to a slight degree.

The complete amplifier consists of four stages, and in order to avoid the overloading of the output valve the stage gain of the two resistance capacity coupled stages is kept down to a low value. Hence the anode resistors are in each case only 20,000 ohms., and the valves employed must be of the power class such as the M.L.4, AC/P., or 104V. If battery valves are used, the P.2 type is recommended.

The third stage introduces the special coupling which places this amplifier very high in the scale of design.

Readers may experience some difficulty in hailing with adequate enthusiasm the appearance in the diagram of Fig. 105 of three transformers. They will, doubtless, remark that this is an expensive arrangement for a single stage coupling; but it must be pointed out that the result amply justifies the extra cost. Besides which, it is hoped that most of my readers already possess at least one of these well-known components. The circuit in Fig. 105 is self-explanatory, all the connections being quite clearly marked. The shorting switch across the secondary wind-

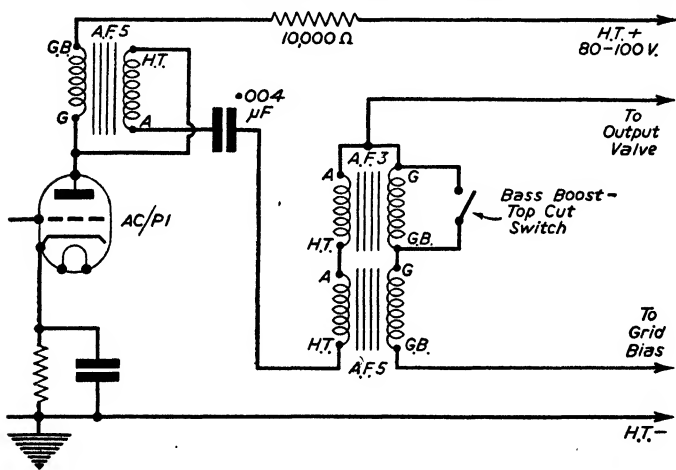

FIG. 105.—The special coupling between the third and last valves of Circuit No. 55.

ing of the A.F.3 transformer should be noticed, since with this winding short-circuited the response curve of the amplifier undergoes a change which should be easily perceptible, even to the average ear. What happens is that the lower frequencies below 500 cycles are gradually increased in strength till at 50 cycles a gain of twelve decibels is attained, while in the upper portion of the curve the response starts falling above 6000 cycles till at 10,000 the decibel loss reaches the figure of ten. Unless a high-range speaker is employed this attenuation in the upper register may be barely noticeable, though if a peak occurs in the speaker or microphone characteristic, (or in the pick up, as the case

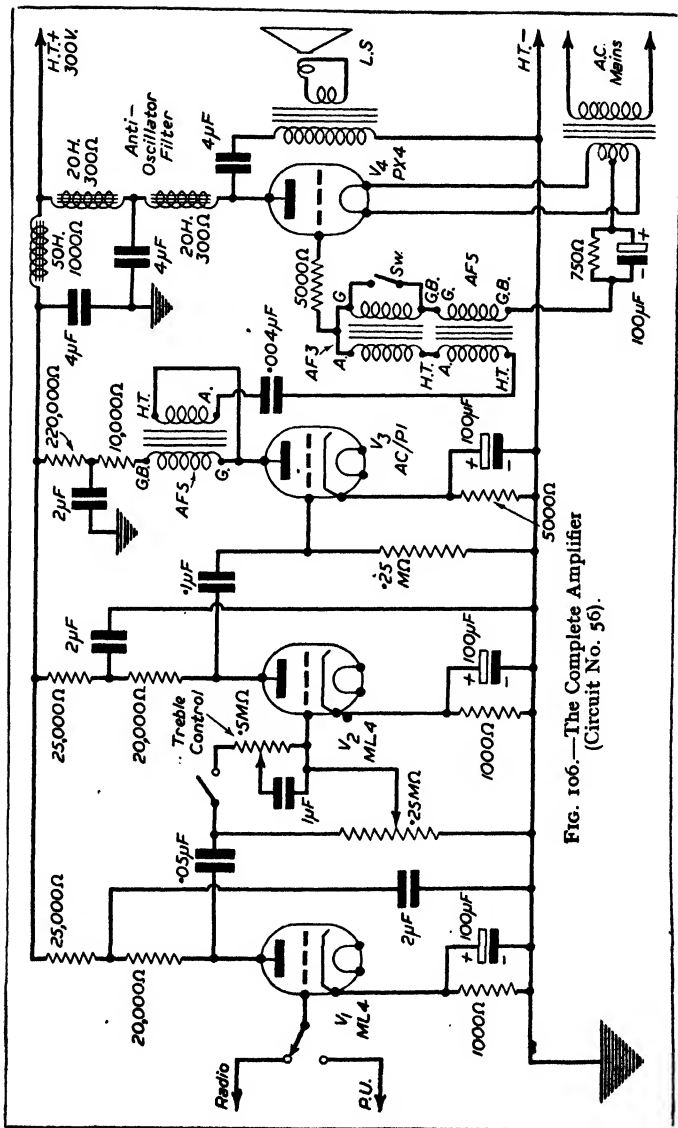

Fig. 106.—The Complete Amplifier (Circuit No. 56).

may be), the fall in the response curve may effect a gratifying result. It is hardly necessary to stress the advantage of such a curve in cases where the transmission presents high-note distortion or heterodyne whistles interfere with the pleasure of reception. For gramophone work the shorting of the secondary winding of the A.F.3 will in most cases prove the more satisfactory course, but much depends on the type of loud-speaker in use.

The large winding of the A.F.5 transformer in the anode circuit of the third valve (also a power valve of the M.L.4 class) makes it absolutely essential to keep the current dissipation down to a low point. After the most careful study it has been found that the optimum flow of current at 100 volts is 0.75 milliampere, the object being to avoid core magnetisation and consequent amplitude distortion. A series resistance of 10,000 ohms. is inserted between the point of high tension and the "G.B." terminal of the transformer, and this resistance forms part of the anode circuit. The valve selected for this stage is the AC/P1 or its equivalent.

The output stage follows normal practice, and while it will be observed that only one P.X.4 valve is employed, there is no reason why two of these should not be used in parallel, or for that matter, why an output valve of the 400-volt class, such as the DO.26 or P.X.25 should not be substituted, if desired. The voltage-dropping resistances must in this latter case be increased in proportion in accordance with Ohm's law. Attention is drawn to the special arrangement to obviate instability in the output valve by means of the extra de-coupling choke and condenser (which duplicates the output filter components) and the 50-henry smoothing choke which is inserted between the main high-tension voltage line and the anode feed supply to the earlier stages including the high-frequency amplifier. The complete circuit diagram of the amplifier is given in Fig. 106. Readers may be interested to know that several examples of this amplifier have been made and the results are phenomenal.

Circuits Nos. 57 to 59.—It is not difficult for *bona fide* experimenters who have a sound knowledge of radio principles to obtain a licence to use a "dummy" or artificial aerial; that is, one which will not permit the radiation of signals beyond the walls of the holder's premises. Such

people will find a simple transceiver a very convenient initial form of equipment.

A simple transmitter is almost identical in main principles with a simple single-valve receiver. The chief difference is that the receiver, with reaction, is used in a state just short of oscillation, while the principal object of a transmitter is that of providing sustained oscillations. In the case of C.W. or morse transmissions the oscillation is interrupted by means of the tapping key, whilst when telephony is being transmitted, the sound or audio frequencies must be super-imposed on the steady oscillation.

Fig. 107 shows a typical circuit for a single-valve receiver with capacity-controlled reaction. Values given apply chiefly to a short-wave receiver for wavelengths between about 16 and 100 metres, but connections would be the same if it were to be used for medium- and long-wave reception; in that case the tuning and reaction condensers would have higher values.

As you are well aware, this circuit could be caused to oscillate simply by increasing the capacity of the reaction condenser. In that state it would radiate, through the medium of the aerial, a steady oscillation. That oscillation would be the equivalent of the carrier wave of a normal transmitter. Consequently, in order to use the receiver for transmitting it would be necessary only to "inject" into the oscillatory circuit audio frequencies. That could be done by including the microphone and microphone transformer, along with a dry battery to energise the microphone, in one of various positions in the circuit (Fig. 108). Three suitable positions are indicated by means of crosses; one is in the anode circuit, the other is in the earth circuit, and the third is in the grid-return circuit.

Of these, the last mentioned is generally most satisfactory, and a modified circuit—this time of a transmitter with a form of grid modulation—is shown in Fig. 108. The similarity between the two arrangements is very clear. The only important difference is that the H.F. choke is connected directly to H.T. + instead of through the 'phones. In addition to this, it will be seen that the values of grid condenser and leak are different and that the lower end of the grid coil is not joined to the earth line.

For satisfactory working, the valve should be of the small power type and should be fed with not less than 120 volts H.T. If a sensitive microphone were employed

it might also be necessary to increase the value of the reaction condenser to ensure continuous oscillation. The reason for this is that strong audio-frequency inputs would tend to stop the oscillation. Explained in terms of the received signal, this would mean that speech or music would be "bubbly" and seriously distorted. The coil might be of precisely the same type and size as used for the receiver in Fig. 107, and would generally be a six-pin plug-in coil of the usual pattern.

Fig. 109 shows how the two circuits already referred to could be combined in a fairly simple manner. It can be

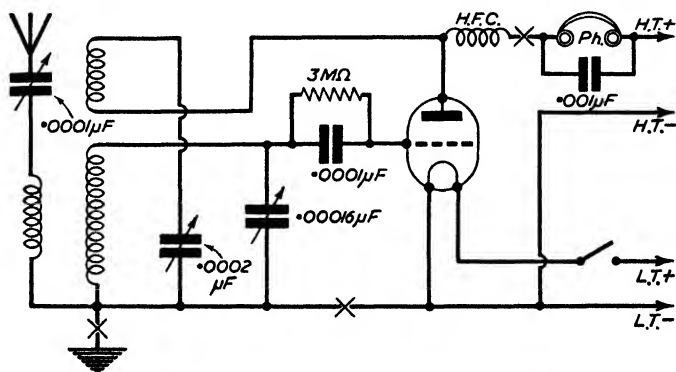

FIG. 107.—A normal type of Single-Valve S.W. Receiver (Circuit No. 57). Points at which audio frequencies can be injected are marked X.

seen that two grid leaks are connected in series; one has a value of 3 megohms (as required for reception) and the other of 10,000 ohms, as used for transmission. A simple on-off switch is used to short-circuit the 3-megohm resistance when the set is being used as a transmitter. A second on-off switch, marked S.2 is used to short-circuit the secondary of the microphone transformer during reception, while there is a third switch, S.3 which serves to short-circuit the 'phones when transmitting. In practice it would be desirable to combine these three switches for one-knob operation. The knob would give two positions—transmit and receive.

Of the three switches, S.1 and S.3 must be closed and S.2. open for transmission, and *vice versa*. This switching combination could be obtained in several ways, but it is

obviously important that there should be a minimum of capacity between the three sections. In many respects, therefore, it is best to employ three baseboard-mounting

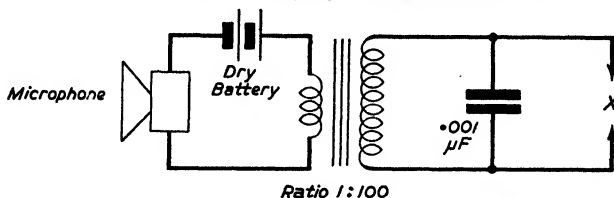

FIG. 108.—Connections for a Microphone and Microphone Transformer to provide the audio frequencies in connection with Circuit No. 57.

toggle switches controlled by a common spindle. One of the switches, S.2. should be mounted in the opposite direction

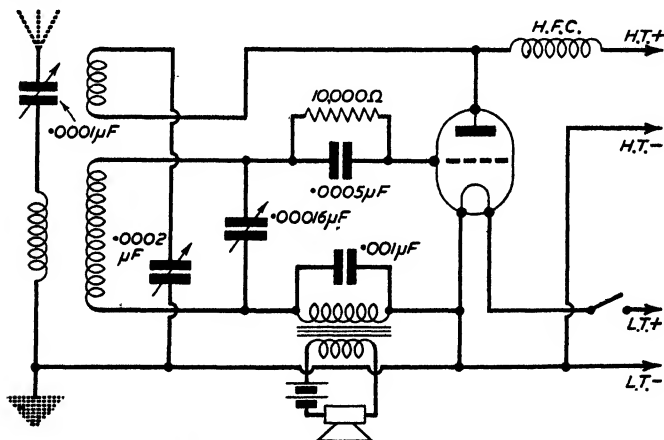

FIG. 109.—The similarity between this simple Transmitting Circuit (Circuit No. 58) and the Receiving Circuit shown in Fig. 107 is obvious. Aerial and Earth are shown broken because these will be replaced by a "dummy" aerial when a full transmitting licence is not held.

to the other two so that it is "on" when the others are "off." To avoid capacity and other losses the three switches should be placed as near as possible to the components they control, and should not be mounted directly on a metal

chassis. An alternative switching arrangement consists of employing a three-pole double-throw anti-capacity switch.

Connections for both of the systems mentioned are shown in Fig. 110.

Tuning Difficulties.—One of the great objections to any form of transceiver is that the tuning has to be changed almost every time the switch is turned from the transmit-to-receiver and receiver-to-transmit positions. Consequently, the tuning scale should be clearly marked at the correct

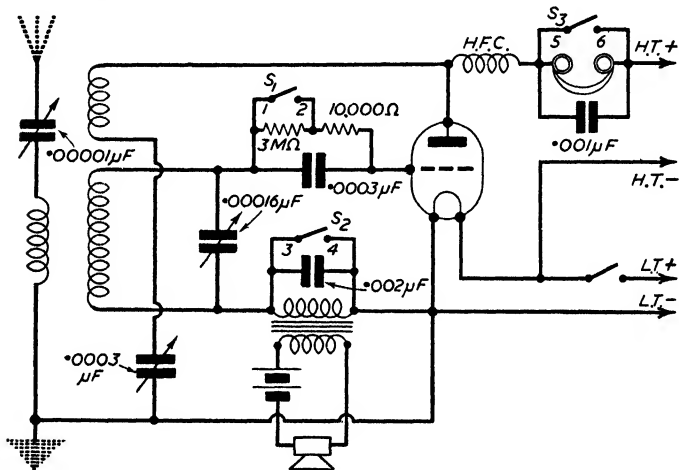

FIG. 110.—How Receiver and Transmitter Circuits can be combined to form a transceiver by means of a simple switching system (Circuit No. 59).

position for the transmitting wavelength. An alternative method would be to have two condensers, one always set to the same wavelength, with a switch to bring either into circuit as required; the switch could be ganged with the other three.

It should be made clear that a simple transmitter of this nature would not be looked upon with favour by the Post Office, due to the fact that there is no system of accurate wavelength control, such as is provided when using a crystal. But, as the set is not in any case intended for use with an "open" aerial, this is not a serious matter. If at any time the set were used by a licenced transmitter on an outside

aerial it would be essential to have an accurately-calibrated wavemeter by means of which the frequency could frequently be checked and adjusted.

On the 5-metre Band.—Transceivers are most frequently used on the 5-metre band (to use, which for transmitting, a special permit is required in connection with the transmitting licence) and on the ultra-short waves they are capable of very satisfactory results. When built in portable form and used in conjunction with a copper-tube aerial only a few feet long, ranges of several miles can often be covered when using an ordinary H.T. battery to supply the power.

Circuit No. 60.—It is possible to use an ordinary moving-

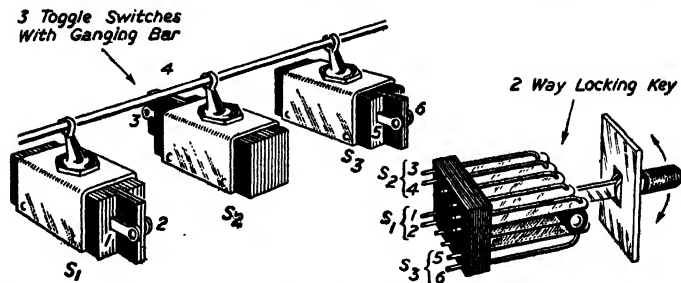

FIG. 111.—Two Transmit-Receive Switch arrangements for Circuit No. 59. The terminal numbers correspond with those in Fig. 110.

coil type of loud-speaker both as a microphone and reproducer and we have also already shown how the speaker may be switched from one position to the other. The unit now to be described utilises this principle and incorporates a two-stage A.C. amplifier with which it is possible to obtain two-way communication over quite considerable distances and with high input sensitivity. Of course, it is possible to arrange that the speaker acts in the dual capacity without the need for a change-over switch for "Talk" and "Listen" positions, but this is a more complicated process and will also be more expensive to construct. It is also to arrange that any pair of sub-stations can call each other and maintain conversation whilst other lines are in action, without interference. The unit here described, however, is of the simplest type and will be found ideal for installation in the home, so

that communication may be established with five different rooms from a central point, and it will also be found of value to a business man who wishes to provide such an installation so that he may be in communication with his various offices or workshops. The complete amplifier and power pack may be made as a self-contained unit which may be called the "Master," and this may be compact enough to stand on a desk. The distant listening points will consist merely of a loud-speaker in a small cabinet.

The Circuit.—Fig. 112 shows the circuit employed from which it will be seen that an input transformer is provided and fed from a 5-point selector switch *via* a special type of change-over switch. The input valve is coupled to the output pentode through a resistance-capacity unit which is incorporated for two reasons. Firstly, it is cheap and avoids troubles which might be introduced owing to the proximity of other transformers in the set, and secondly, the grid leak may be made variable so that a simple but efficient form of volume control may be utilised. The built-in speaker is provided with an output transformer which is also fed to the selector switch through the special change-over switch already mentioned. A standard mains section consisting of transformer, rectifying valve, and smoothing circuit is fitted and this has only one difference from the standard apparatus as used in radio apparatus. This consists of a split negative H.T. feed, the use of which will be explained at a later stage. The various parts may be arranged in any desired manner according to the cabinet which is used, and it should be noted that five pairs of terminals are provided for connection to the five sub-stations. It is possible to dispense with five of these terminals by using a common earth return, but there are drawbacks to this arrangement and the saving of expense is very small.

The selector switch is a standard Bulgin 5-point switch and is mounted on the left of the panel. The change-over switch is a 12-point (four-pole change-over) of the P.O. type. One section of this is not used in this particular design, although, if desired, it could be used to operate a calling-up buzzer circuit.

A full list of components is included on page 163, and it will be seen that the speaker in the Master Unit is a standard W.B. Midget, but the sub-station speakers should be of the same type, without input transformer. It is possible to use ordinary speakers if you have them handy, but the input

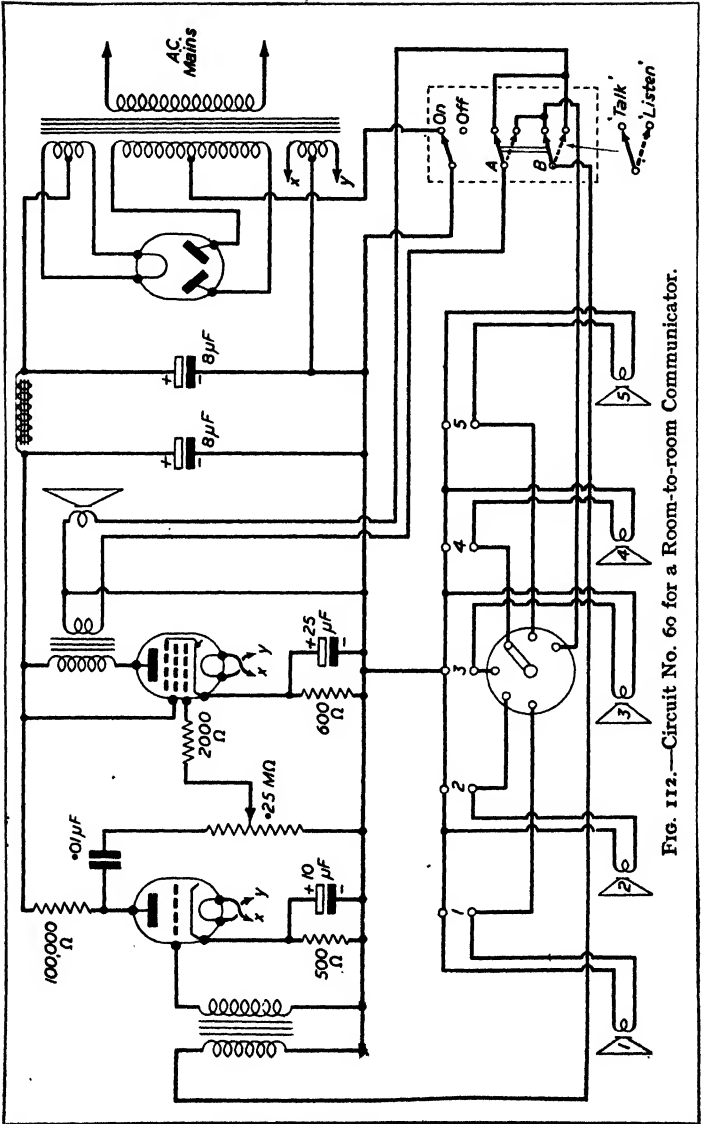

Fig. 112.—Circuit No. 60 for a Room-to-room Communicator.

transformer should be disconnected and the speech coil winding only used. The input transformer is of the microphone type to give better matching to the input grid circuit and also to provide a better step-up ratio to overcome the losses which are introduced when very long leads are employed between the master and sub-stations. For compactness the chassis should be cut away in the front to clear the chassis of the speaker, and holes for the valveholders and for the passage of connecting leads should then be drilled. On the rear chassis strip ten holes should be drilled for the terminals, and a $\frac{3}{8}$ -inch hole for the Bulgin volume control. A mains connection is mounted on the other end of the rear strip, but if desired a mains on-off switch may be placed here instead, and the leads to the nearest mains socket may be permanently attached to the switch and mains transformer. In the former case, the mains must be switched on at the mains plug, but the apparatus may be "disconnected" or rendered inoperative by means of the change-over switch, due to the breaking of the H.T. negative lead previously mentioned.

The panel or cabinet front must be cut to accommodate this change-over switch and two $\frac{3}{8}$ -inch holes drilled for the 5-point selector switch and the small pilot or signal light. This enables the user to see at a glance whether the unit is switched on, and whilst it is kept in a condition ready for use the light behind this small indicator will glow, although, when the switch is in the "up" position it is impossible to talk or listen on the apparatus. This idea avoids the necessity which would otherwise be introduced of waiting for the valves to heat up and thus the apparatus is ready for immediate use at any time. Wiring should be carried out with heavy wire—say 22-tinned copper, and insulated sleeving should be passed over certain of them to avoid possibility of short-circuits. The wiring is very simple and the only point which might introduce difficulty is the change-over switch. The cross connections should be made before the switch is mounted as the contacts will otherwise be found rather inaccessible.

When wiring is completed, the unit should be tested out to make certain that the connections are correct. The valves should light up (with the signal light) when the mains switch is in the "on" position, and the right-hand lever switch should be pushed into the up, or "off" position. If leads are not connected to the five pairs of terminals,

when the right-hand switch is pushed down, the speaker on the Master Unit should hum, showing that the switch is operating correctly. The sub-units or stations consist merely of the small speakers, and these may be mounted in small cabinets, or simply placed in a convenient position in the room. They need not be placed close to where a person sits, and may be tucked away in any convenient position as they will pick up the normal conversation volume of a person in even a very large room although not pointing at the person. Ordinary twin bell-wire may be used for wiring between Master and sub-stations, and if a common earth return is employed the lead to one side of the speech coil on the distant speaker should be connected to the nearest earth point. An earth wire must then be attached to one of the terminals on the rear of the master unit which are shown connected together in the wiring diagram.

In use, the user of the Master Unit simply pushes the change-over switch down to a horizontal position and turns the 5-point switch to the number corresponding to the distant point to which he wishes to speak. An ordinary conversational tone may be adopted and there is no need to raise the voice. When he has spoken and wishes to hear a reply; the switch is depressed, and held in position. On this model the switch remains in an "off" or "talk" position only, and thus to hear signals from any of the sub-stations the lever has to be held.

**LIST OF COMPONENTS—ROOM TO ROOM COMMUNICATOR
(5-WAY)**

2 8-mfd. electrolytic condensers.	1 600-ohm. 1 watt resistor.	1 microphone transformer.
1 10-mfd. electrolytic condensers.	1 750-ohm. 1 watt resistor.	10 terminal (5 red, 5 black).
1 25-mfd. electrolytic condensers.	1 L.F. smoothing choke	1 4-pole switch.
1 '01 mfd. fixed condenser.	1 volume control, '25 megohms.	1 chassis 10 in. x 8 in. metallised surface.
1 100,000-ohm. 1 watt resistor.	1 mains connector,	1 cabinet.
1 2000-ohm. 1 watt resistor.	1 5-way rotary switch.	1 41 M.H.L. Valve.
	1 signal light.	1 M.P./pen valve.
	1 mains transformer.	1 506 B.U. valve.
		1 midget Speaker.

SUB-STATIONS

1 midget loud-speaker, type 37M. without transformer. (One for each sub-station.)

Cabinet to suit above, and to harmonise with room furnishings.

Circuit No. 61.—This dual-wave crystal diode receiver shown in Fig. 113 uses an air-cored coil of fairly large size. It has the advantage that it can be wound easily by the constructor who wishes to make his own coil. A compromise has to be made between selectivity and volume, and two aerial terminals are fitted so that the user can select that most suitable for local conditions. When aerial terminal "A₂" is used the aerial is taken to a centre-tap on the medium-wave section of the coil, and this gives fair selectivity and good volume. Using terminal "A₁" brings in a fixed condenser of $.0002\mu\text{F}$. This particularly increases selectivity on long waves, and helps to prevent long wave break-through where the receiver is used close to a long-wave transmitter.

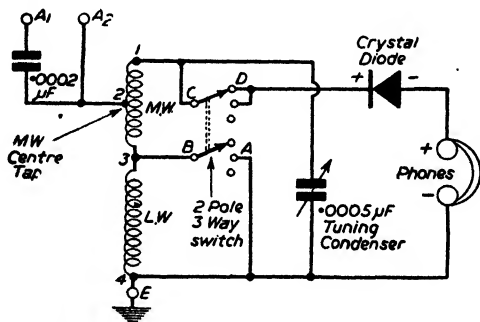

FIG. 113.—Theoretical Circuit of a Dual-Wave Crystal Diode Receiver, Circuit No. 61.

The correct polarity is indicated for the "Phone" terminals because a steady direct current of about 50 microamperes flows when the receiver is tuned to a local transmitter, and with some types of headphones this could cause some slight eventual demagnetisation, if the phones were wrongly connected.

Points on Construction.—The overall dimensions have been kept down so that the completed receiver can be housed in a small, neat cabinet. The panel is 4 in. by 6 in. and the receiver $5\frac{3}{8}$ in. deep, excluding terminals. The polished brown bakelite panel specified ensures that the final appearance is satisfactory. No reduction drive is used with the tuning condenser, as this is scarcely necessary. The large knob, with skirt and engraved line, proves perfectly satis-

factory for tuning. (The suppliers of this knob can also provide a knob with scale, and this could be used instead if the constructor prefers.)

In addition to the specified crystal diode, other similar detectors are available. The Sylvania 1N22 or CV102 may be used and have similar dimensions and characteristics.

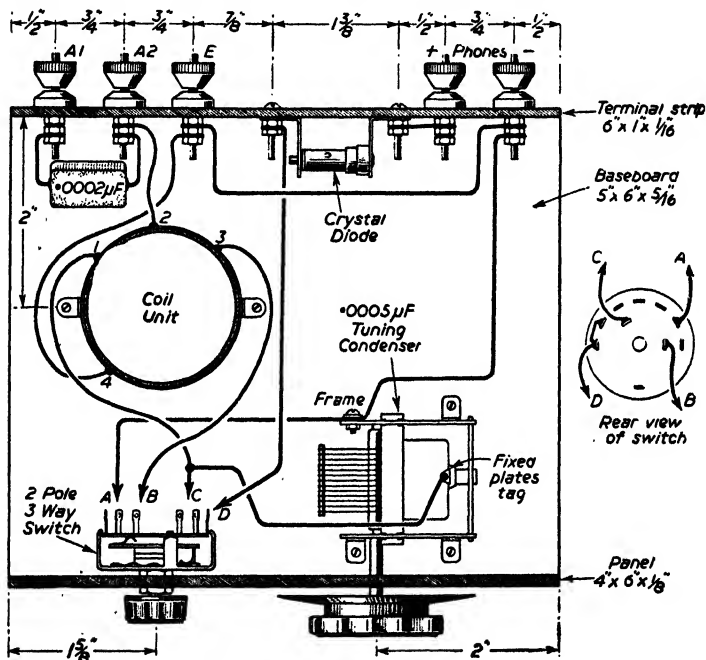

FIG. 114.—Wiring Plan of Circuit No. 61.

When using the 1N22 type, the large end may need scraping because these have a screw which is subsequently covered with hard varnish so that no electrical contact may exist between the detector and mounting brackets.

In order that the tuning control may be in a central position, the tuning condenser is raised by $\frac{1}{2}$ in., and this can be done by placing $\frac{1}{2}$ in. bushes under the fixing brackets, or by placing a piece of wood roughly 2 in. square by $\frac{1}{2}$ in. thick under the condenser, before screwing it in position.

Rotary switches of the type illustrated in Fig. 114 are manufactured in certain sizes, and a lesser number of contacts than the maximum number which can be accommodated on the switch may be found. The same type of wafer is used for both two-, three- and four-pole switches. As only two poles are required, the other contact tags are ignored, if fitted to the switch. If they are not fitted, part of the wafer may appear blank. These points sometimes appear to confuse constructors who have never used this type of switch before, but if a two-pole, three-way switch is ordered they can be sure that this is suitable, and if extra contacts are found on the actual component, these are disregarded.

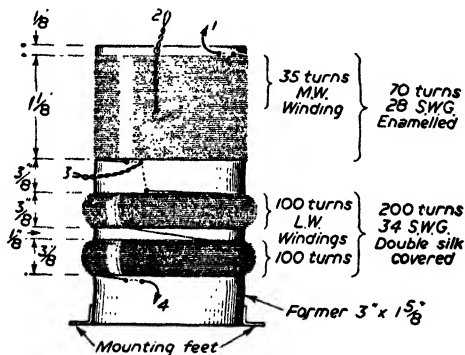

FIG. 115.—Coil Data for Circuit No. 61.

Fig. 115 makes the construction of the coil quite clear. The dimensions between the respective windings are not critical, but given as a guide to the disposition of the windings. The ends are secured by passing them through small holes in the former, and should be left 4 in. or 5 in. long to reach to the various parts in the receiver. Point "2" is formed by making a loop in the wire, and point "3" will consist of *two* ends of wire, twisted together—the junction between medium- and long-wave sections of the coil. All turns must be wound in the same direction.

Aerial, Earth, and Phones.—The best aerial is a fairly long, outdoor one, situated as far as possible from buildings and other earthed objects, and as high as possible. However, circumstances often prevent such an aerial being erected, and

good results can be obtained with other types. Whatever kind of aerial is used, it should be insulated by using one or two aerial insulators at the points of suspension. The down-lead should not descend against the house wall, but be kept a few feet away, if possible. Losses will then be avoided (and these can be severe in wet weather, if the down-lead is attached to brickwork), and signal pick-up increased. An average outdoor aerial could consist of about 50 ft. of wire, this forming both the down-lead and horizontal portion. If space permits, a longer aerial can be used, with some slight increase in volume.

An indoor aerial can be made from any insulated wire,

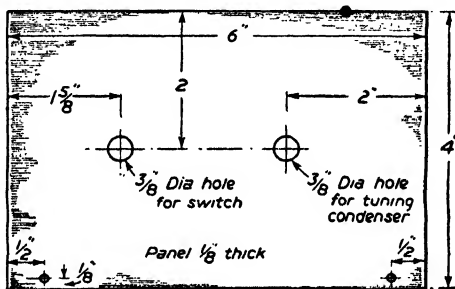

FIG. 116.—Details of the Panel.

which is usually placed round the picture rail, against the wall. It is sufficient to take the wire along two walls of the room. If it can only be taken along one wall, sufficient volume may still be obtained, though the wire is then likely to be somewhat short. In a bedroom, results with the aerial at floor level will be found to be similar to those when the wire is near the ceiling. Under reasonable conditions an indoor aerial should be satisfactory. However, it cannot provide as much signal pick-up as a good outdoor aerial. If the building has a metal fabric or steel framework then an outdoor aerial is likely to be essential.

The earth lead should be taken to a metal object actually buried out of doors. Earthing spikes are obtainable for this purpose, or the wire may be securely attached to any metal object (preferably of a type not likely to corrode). In some cases an earthing point may be available in the house, or a descending water main can be used.

A wide variety of headphones can be operated with success, but *low* impedance headphones are *not* suitable. Balanced-armature headphones, now readily obtainable, are satisfactory; so are medium- and high-impedance phones of all types. Moving-coil phones are not suitable, being of low impedance. If it is particularly desired to use such phones, or other low-impedance types which may be to hand, then a matching transformer is required. The primary of this should be connected to the phone terminals on the receiver, and the headphones should be taken to the transformer secondary. The transformer *must* be of correct type for the phones used; if it is not, volume will be reduced. The usual speaker-matching transformer is *not* suitable for most moving-coil phones, as the latter are of somewhat higher impedance than the normal loud-speaker.

(BLUEPRINT NO. P.W.65)

COMPONENTS FOR THE DUAL-WAVE "CRYSTAL DIODE"

J.B. Standard .0005 μ F. tuning condenser with mounting feet. (Coventry Radio.)

Type C1065.S. 2½-in. knob. (Coventry Radio.)

¾-in. diameter knob. (Coventry Radio.)

2-pole 3-way wafer-type rotary switch. (Coventry Radio.)

5 4-B.A. terminals type C2512. (Coventry Radio.)

.0002 μ F. fixed condenser (Dubilier, etc.). (Coventry Radio.)

Crystal diode with mounting brackets. (Post Radio Supplies.)

Brown Bakelite panel 6 in. \times 4 in. \times ¼ in. thick. (Post Radio Supplies.)

Terminal strip 6 in. \times 1 in. \times ¼ in. (Post Radio Supplies.)

Coil former 3 in. by 1½ in. diameter, 2 oz. 28 S.W.G. enamelled

wire, and 2 oz. 34 S.W.G. D.S.C. wire. (Post Radio Supplies.)

Wood for baseboard, screws, etc.

Circuit No. 62.—Operating wholly from dry batteries, the one-valver shown in Fig. 117 has a high degree of sensitivity and tunes medium- and long-waves. The more powerful transmitters may be received at excellent strength even when using a very short indoor aerial and when no earth connection is available. With an earth and an aerial of average efficiency quite a large number of stations may be picked up, especially towards evening, when many European transmitters come within range of the receiver. The constructor who requires better results than those obtained with a crystal set will find such a receiver ideal, and it is, of course, very considerably more sensitive and selective than a crystal

set. It can also form the basis for a loudspeaker receiver of efficient and economical type, if desired, by the subsequent addition of an output stage.

An octal pentode is used and this has a 1.4 v. .05-amp filament. Though a 1N5 is specified, equivalents which will perform equally well can be used. These are the Mullard DF33 and the Marconi/Osram Z14. The 1N5/GT type is equally satisfactory, merely having a glass bulb of different size. As will be seen, the current consumption is very small, which means that the batteries will have a long period of useful life. If midget or layer-type batteries are used they

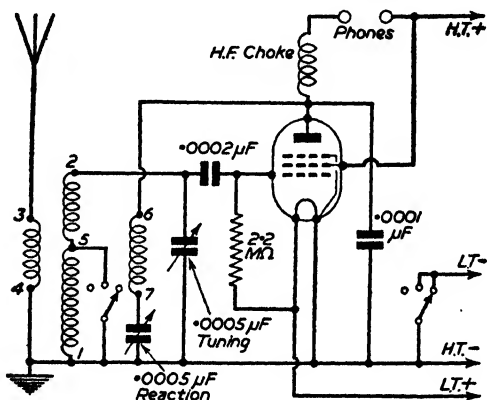

FIG. 117.—Circuit No. 62 of a One-Valve Receiver.

may be situated on the chassis, where sufficient space is left to accommodate them. A H.T. voltage of 45 to 60 or so is ample, and suitable "Drymax" Exide batteries of layer-type are the 502, 45 volts, or 501, 67½ volts. Other batteries of similar type, produced by different manufacturers, are equally suitable. With such a battery the receiver may be enclosed in a cabinet approximately 8 in. by 8 in. by 5 in. from back to front (inside dimensions), thereby being self-contained and quite compact. For filament supply a wide variety of dry batteries are available. That used may be of the type especially made for "All-Dry" receivers, or a torch or flashlamp battery can be used. In the latter case, it is essential to remember that the voltage must not exceed 1.4 (as obtained from a single dry cell, or two or more cells wired in *parallel*).

If more than one cell is used for filament current, the cells should be connected in parallel and the carbon rods (centre connection) will form the positive terminal.

If size is of no object then a H.T. battery of ordinary type can be used; these are substantially cheaper and have a longer life than the midget types. Such batteries are the Exide H.1,003, 60 volts, and H.1,156, 45 volts. These batteries are too large to accommodate on the chassis. In the event of such types not being in stock they can always be obtained from the makers. Similar batteries of other manufacture are also available.

Chassis and Construction.—The chassis is made from a piece of aluminium 8 in. by $8\frac{1}{2}$ in., two runners being bent along the shortest edges so that the completed chassis is 8 in. by 5 in. by $1\frac{3}{4}$ in. deep. If the metal is held tightly between two boards secured in the vice these bends may be accomplished readily and accurately. The positions of the various holes will be seen from Fig. 118, and that for the valveholder is best made with one of the special cutters available for this purpose. The holes for the switch and reaction condenser, situated on the front runner, require to be about $\frac{3}{8}$ in. in diameter. Holes of this size should also be drilled to clear the aerial and phone sockets, where these project through the rear runner. It is preferable to drill all holes before mounting any of the components, to avoid possible damage and keep the various parts free from metal fragments.

When bolting the valveholder and socket strips in place soldering tags are added to provide earthing points. These are marked M.C. to show that the leads in question are returned to the chassis; 6-B.A. bolts about $\frac{3}{8}$ in. long are a convenient size to use.

In order that the spindle of the tuning condenser may be high enough to reach the tuning dial bush, it is necessary to employ spacing pieces under the mounting feet of the condenser. The exact length of these is not important because the dial has a slotted mounting bracket so that its height may be adjusted, but they should be not less than $\frac{1}{2}$ in. in length. Bushes may be used, or $\frac{3}{4}$ in. long bolts, each with three nuts, two being locked against the chassis to raise the condenser, as illustrated on Fig. 118.

The H.F. choke is secured by a single 6-B.A. bolt driven into the tapped hole at its untagged end. The tuning coil is mounted on the chassis by the long tag or loop provided; this also returns the one winding to chassis. When wiring

up, the battery leads are passed out through a hole in the rear runner, and a rubber grommet is necessary here in order that the insulation does not become cut, thereby causing a short circuit. A suitable hole for this purpose should be drilled initially.

Wiring Points.—All the connections are illustrated, and only two pass through the chassis. One of these goes from tag 2 on the tuning coil to the fixed plates tag of the tuning condenser. The second, of thin flex, goes from tag 6 on the valveholder to the top clip of the valve. Tag 6 is only used

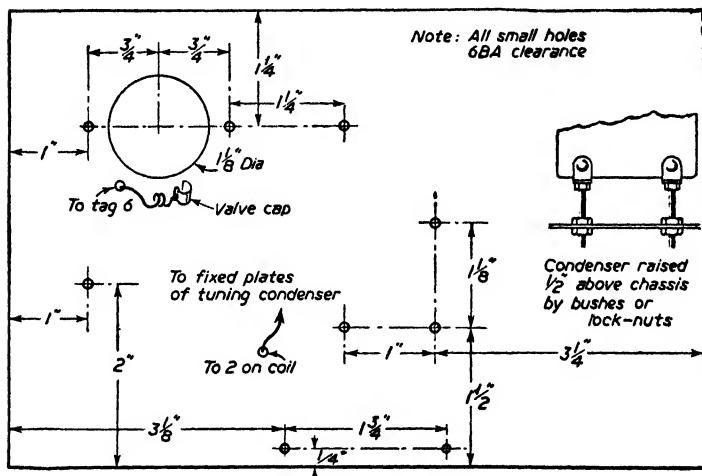

FIG. 118.—Details for Drilling Chassis.

to secure the 2·2 megohm grid leak and ·0002 mfd. grid condenser, and no pin to correspond with it is present on the valve.

The wiring to the switch should present no difficulty, even to beginners, and a rear view of the tags is given. In one position the set is "Off." When the switch is turned to the next position the filament supply is switched on and tag 5 and the coil returned to chassis; this position provides "medium waves." In the third position, the set is still switched on, but tag 5 is not returned to the chassis. This position accordingly provides "long waves." The five coil tag connections will also be seen from the inset diagram in

Fig. 119 which shows the coil as seen from the end equipped with bracket or loop to bolt to the chassis, as already mentioned.

Any thin insulated wire may be used for the connections, something in the neighbourhood of 22 S.W.G. tinned-copper being easy to work with and solder. (*Very thin wire should not, of course, be used.*) The moving plates of the reaction

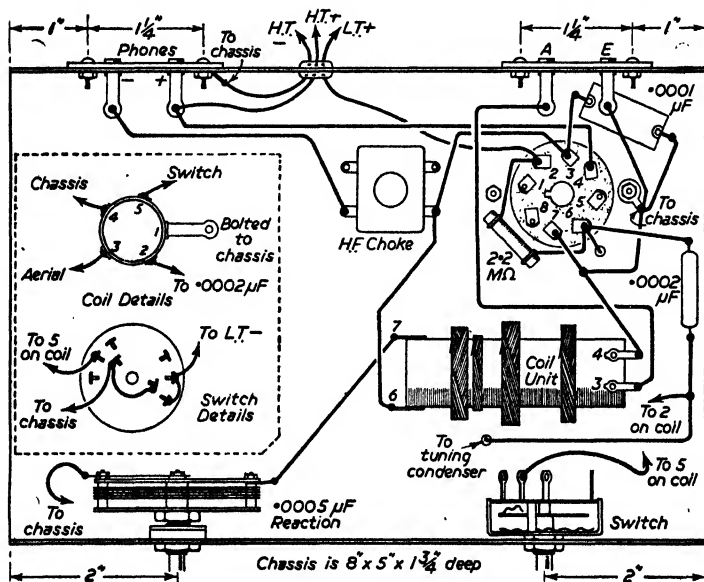

FIG. 119.—Wiring Plan of Circuit No. 62.

condenser will already be in contact with the chassis, through the fixing bush. However, as this may give rise to loud crackling, as the control is operated, a lead from tag to chassis, as indicated, is necessary.

Operational Notes.—When wiring is completed the valve should be inserted, the top clip placed on, and the batteries connected. The L.T. leads must be marked to distinguish them from the H.T. leads and more than 1.4 v. must not be applied to the filament. The headphones should be of the usual type, preferably of high impedance. Suitable phones are available from many different sources, but low-impedance

phones should be avoided, or used with a high-to-low impedance *headphone* matching transformer.

The receiver will give good results with many different aerial/earth systems. If long-range reception is required, a good aerial and earth will prove helpful. A very short indoor aerial will be sufficient for local station reception. Such an aerial can consist of a length of thin flex placed as convenience allows. With a more effective indoor aerial, consisting of an insulated wire along two walls of the room, near the ceiling, a somewhat greater range will be obtained.

As the coil has an aerial coupling winding a good degree of selectivity results for this type of receiver and tuning is quite sharp. With a very long aerial, however, it will be desirable to include a small condenser in series with the aerial lead-in. A pre-set of $\cdot 0001 \mu\text{F}$ is most generally suitable. If a fixed condenser is used, a capacity of $\cdot 0001$ or $\cdot 00005 \mu\text{F}$ is likely to be best. Smaller capacities will further increase selectivity, but will reduce volume unduly. If the receiver is used very close to a major transmitter, this condenser is recommended, even with an indoor aerial.

A station near the middle of the tuning range should be tuned in accurately and the tuning pointer may then be adjusted slightly as necessary to give an accurate indication.

COMPONENTS FOR 1-VALVER

- $\cdot 0005 \mu\text{F}$. J.B. tuning condenser with feet. (Coventry Radio.)
- $\cdot 0005 \mu\text{F}$. "Wavemaster" reaction condenser. (Coventry Radio.)
- Dual-wave coil with reaction and primary. (T. G. Howell.)
- H.F. choke type QC1. (Osmor Radio Products Ltd.)
- J.B. square 2-waveband dial, complete. (Stern's Radio.)
- Knobs: 1 K254 for tuning, 2 K6 for reaction and switch, or similar. (A. F. Bulgin & Co. Ltd.)
- Aerial, earth, and output sockets. (Stern's Radio.)
- $\frac{1}{2}$ -watt 2.2 megohm grid leak. $\cdot 0002 \mu\text{F}$. grid condenser.
- McMurdo international octal valveholder. (Premier Radio Co.)
- 2-pole 3-way rotary switch. (Coventry Radio type C1780T, or similar.)
- Chassis, 8 in. wide by 5 in. by $1\frac{1}{4}$ in. deep.
- 1N5 or equivalent valve. Valve cap, leads, etc.

Circuit No. 63.—Though the one-valve receiver can give very good results it is, of course, unsuitable for loud-speaker operation. However, those who wish to use a speaker can add an output stage without much difficulty, thereby arriving at a two-valve circuit. Used with an average aerial and earth, the volume obtained from such an arrangement equals

that provided by the four-valve superhet all-dry receiver of equivalent type and employing a frame-aerial as the only source of signal pick-up. With a short indoor or temporary aerial good volume is still obtainable, largely due to the presence of reaction to build up weak signals. Such a two-valve circuit accordingly recommends itself where economical operation and low initial cost are important, and where portability is not an essential requirement.

Filament current can be obtained from any 1·4-volt dry battery, of which many types are available. For H.T. purposes a 90-volt battery is recommended. If size and weight are to be kept down, a layer-type, such as the Drydex 526, is suitable. If size is not important, a battery with standard cells can be used with advantage, since these are both cheaper and have a longer life. As standard 90-volt batteries are readily available from a variety of manufacturers it is not proposed to specify any particular kind. It should also be noted that the receiver will give good results with a 60- or 67½-volt battery, though volume is naturally slightly reduced. The total filament consumption of the two-valver is ·15 amp., the output valve being a 3Q5 beam tetrode, which will deliver approximately 0·27 watts with a 90-volt H.T. battery. Equivalent valves are the Marconi-Osram N15, and Mullard DL33. 3Q5 valves with the G/GT designation are also equally suitable.

Circuit Details.—The wiring already in the one-valver (Circuit No. 62) remains unchanged except for 'phone leads and H.T. negative connection. The output sockets on the rear runner are now wired for the speaker, and the H.T. negative lead is removed from the tag in contact with the chassis, going instead to the condenser and resistor which provide auto-bias for the output valve.

An additional ¾-in. diameter hole is drilled centrally in the front runner to take the ·5 megohm volume control; the wave-change switch and reaction condenser are left untouched, together with their wiring. It is also necessary to drill a further 1½ in. diameter hole for the additional valve-holder, with three 6-B.A. clearance holes to mount the holder and bias condenser. The circuit diagram is shown in Fig. 120.

The 1N5 detector now functions with a high anode impedance (·3 megohms) and gives very excellent results with this. Since the valve cannot function properly if the screen-grid voltage exceeds the anode voltage a 2-megohm screen-grid dropper is introduced, with a ·1 μF by-pass condenser

to chassis. Grid bias is developed by the voltage drop across the 450-ohm resistor, the grid of the 3Q5 being thereby maintained at about 4.5 volt negative, in respect to the filament. To preserve stability this resistor is shunted by a condenser of high capacity. Volume may be adjusted from zero to maximum by means of the .5 megohm potentiometer, and the receiver remains equally suitable for headphone use. The .002 μF condenser wired in parallel with the output sockets serves to reduce top-note response slightly, thereby making reproduction more natural.

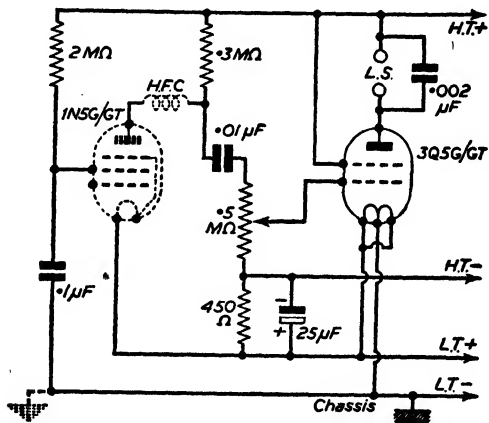

FIG. 120.—Theoretical Circuit of a Two-Valve Receiver, Circuit No. 63.

Points about Wiring.—An examination of the diagram should make all connections perfectly clear, but one or two items might be mentioned to ensure that no difficulties arise.

The lead which previously went from the H.F. choke to one 'phone socket is removed, the .3-megohm resistor and .01 μF coupling condenser instead going to the choke tag. The lead from tag 4 of the detector valveholder to H.T. positive is also removed, the 2-megohm resistor and .1 μF condenser being added as shown. Filament current for the 3Q5 is taken from tag 2, as illustrated in Fig. 121. The 3Q5 has a centre-tapped filament, the halves here being used in

parallel for 1.4 volt operation. No changes in other wiring are made, but the $0.0001 \mu\text{F}$ anode by-pass condenser in the one-valver will have to be moved a little from its original position to make room for the new $0.1 \mu\text{F}$ condenser.

The bias condenser is soldered to a tag bolted to the chassis. It is important to note that the *positive* tag of the condenser goes to the chassis. The negative tag, and metal casing, if common to this tag, must be kept away from the chassis. If this is not done no bias voltage will be developed, with a consequent reduction in volume, quality of reproduction, and valve life. H.T. consumption will also be considerably increased.

The mounting bush of the volume control must be "dead" and not in contact with the slider, or centre tag. This is so with modern controls of reputable manufacture, but must be watched if an old control or surplus component is employed. In the event of bush and slider being in electrical contact, the control should be insulated from the front runner by means of ebonite or similar washers.

Speaker Matching, etc.—The receiver will give excellent volume and quality if used with a loud-speaker of reputable manufacture. Correct impedance matching is necessary, and the optimum load of the 3Q5 is 8,000 ohms. If the speaker has the usual impedance of 2 to 3 ohms a transformer of approximately 60:1 ratio is required. In the event of a speaker of 15 ohms impedance being used, the ratio should be about 23:1. It will, therefore, be seen that it is essential that the speaker and transformer be selected for use together, or poor results will arise. A coupling transformer intended for a 2- to 3-ohm speaker is not suitable for the 15-ohm type. It should also be noted that ordinary D.C. measurements of the resistance of the speaker speech-coil will not reveal its impedance, since the D.C. resistance of the 15-ohm type may not exceed 2 to 3 ohms. This also applies to the primary and secondary of the output transformer, where the values, read with a D.C. meter, will be very much lower than the impedance. Nor will the secondary of the output transformer and speech-coil, measured separately, necessarily have the same D.C. resistance, since the gauge of wire used is normally very different.

However, many manufacturers produce speakers complete with output transformer, and several suitable "Stentorian" models can be recommended. Some manufacturers classify their output transformers according to the type of output

valve with which the transformer is to be used. If this is so with the type obtained, a transformer for "high impedance battery pentode" should be obtained. A transformer for *mains* pentode is unsuitable, since the optimum load of these valves may be as low as 2,500 ohms or less. If a multi-ratio transformer is used, the tags giving best results should be used.

Finally, for best reproduction the speaker must be

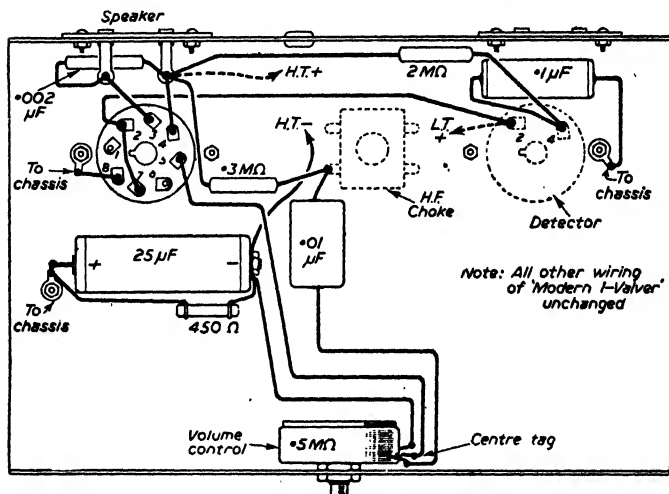

FIG. 121.—Wiring Plan of Circuit No. 63.

mounted in a cabinet or secured to a baffle board. For normal use a 5-in. to 7-in. speaker is most suitable. (This dimension refers to the diameter of the cone.) It must, of course, be of the permanent magnet type.

COMPONENT LIST

- 2 megohm, .3 megohm, and 450 ohm resistors.
- .1 μF. paper by-pass condenser. (T.C.C., etc.)
- .01 μF. mica coupling condenser. (T.C.C., etc.)
- 25 μF. 6- to 12-volt bias condenser. (T.C.C., etc.)
- .002 μF. paper tone-correction condenser. (T.C.C., etc.)
- .5 megohm volume control and knob.
- 3Q5 or equivalent valve.
- International octal valveholder.

Circuit No. 64.—This all-dry three-valve receiver is for general use. The receiver is compact, but no form of midget construction has been employed, so that wiring and component layout is not cramped. The circuit should particularly recommend itself to those who require a sensitive all-dry receiver, but feel that the usual four-valve superhet is rather complicated and difficult to align. In this receiver there are only two trimmers to adjust, and the settings of these are not very critical, though naturally sensitivity is only at its best when they have been adjusted for maximum volume.

The receiver maintains good volume with even a very short aerial and no earth, and this means that it may readily be used upstairs or in other rooms. It is proposed to conclude with a few details of satisfactory aerials, both indoor and outdoor, for the benefit of those who feel they require some guidance on this point. The circuit is shown in Fig. 122.

Two pentodes and a beam tetrode are used, octal valves having been selected because they are somewhat more robust than the all-glass button-based type. The tapped filament of the 3Q5 output valve is wired for 1.4-volt operation, since this permits a 1.5-volt dry battery to be used and also enables a slightly greater power output to be realised than when the series method is employed. With a power output rating of .27 watt (with a 90-volt H.T. battery) this valve enables ample volume to be obtained, especially as a midget loud-speaker is not necessary.

In order that the total number of controls may be kept down to three, a combined reaction and volume control arrangement is used. With reaction at minimum, volume can still be too great when local stations are tuned in. So the usual reaction condenser has been abandoned, and a potentiometer used. As reaction is reduced the resistance value from aerial input to earth is decreased, and can be brought to zero. For the first part of its rotation the potentiometer functions as a volume control by increasing the resistance in parallel with the aerial winding; after roughly a half-way position the amount of R.F. energy passed through the reaction winding and .001 μ F condenser begins to make itself felt, and the detector may be brought up to the oscillating point in the usual way. This ensures maximum sensitivity on weak stations.

The second knob is a three-pole three-way rotary switch, wired to provide "Off," "Medium-Wave" and "Long-Wave" positions. The remaining knob is the usual tuning

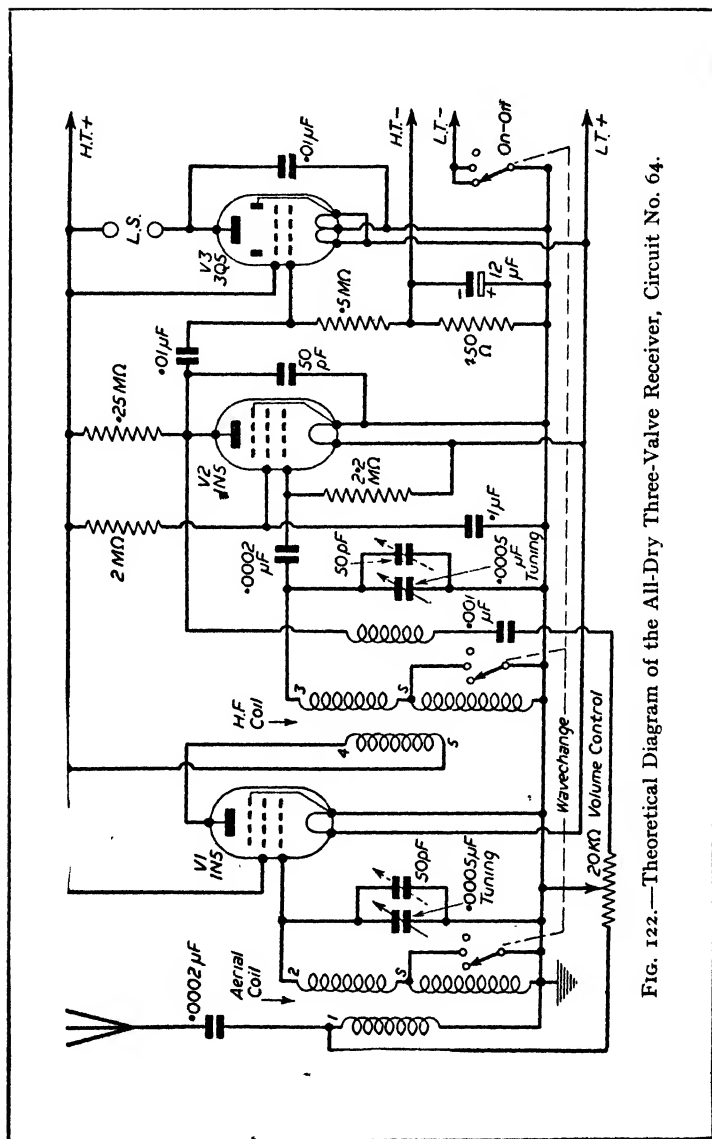

FIG. 122.—Theoretical Diagram of the All-Dry Three-Valve Receiver, Circuit No. 64.

control, and the dial is marked with wavelengths and station names. Two types of dial are available. The first is of printed card, and is placed behind the pointer. The second is of glass, printed with the usual markings, and can be placed in front of the pointer (*e.g.*, fixed in the cabinet front). When the latter dial is used the pointer should be backed up by a piece of white or tinted card. No dial lamp is used in view of dry batteries being employed.

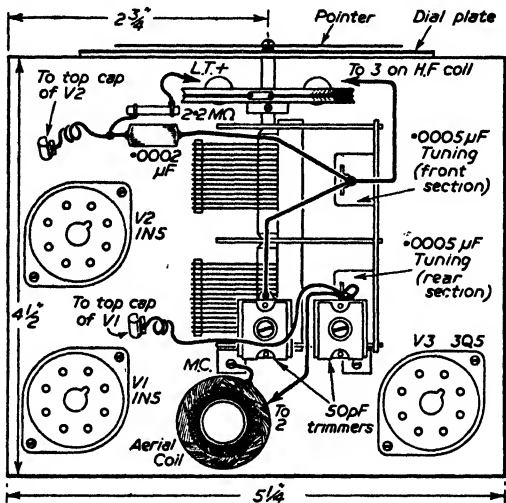

FIG. 123.—Chassis Layout of Circuit No. 64.

Chassis Details.—The chassis is made from a piece of aluminium $5\frac{1}{4}$ in. by $7\frac{1}{2}$ in. Two runners are bent to a depth of $1\frac{1}{2}$ in. so that the completed chassis is $5\frac{1}{4}$ in. by $4\frac{1}{2}$ in. by $1\frac{1}{2}$ in. deep. Holes for the valveholders are drilled with their centres $\frac{3}{8}$ in. from sides and rear. Three $\frac{3}{8}$ -in. diameter holes are drilled for the controls, $\frac{3}{8}$ in. from the lower edge of the front runner, and spaced as indicated in the diagrams. Other holes are drilled for the "aerial" "earth" strip. The earth socket may be in contact with the chassis, but clearance should be allowed around the aerial socket.

Holes about $\frac{3}{8}$ in. in diameter are drilled for the cord to pass from the tuning dial drum to the spindle below, and a

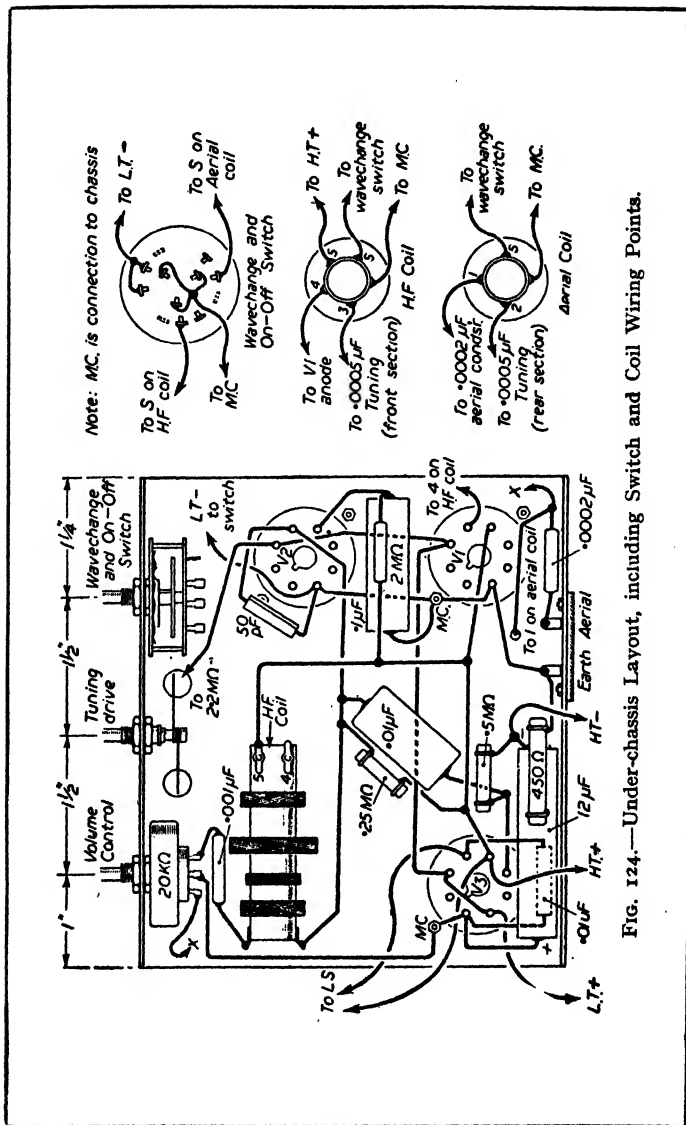

FIG. 124.—Under-chassis Layout, including Switch and Coil Wiring Points.

further small hole is required near the aerial coil. After securing the gang condenser in position the drum should be placed loosely on the spindle. The tension spring is hooked to the drum and the cord threaded through the slot in the perimeter, and through the loop at the free end of the spring. One end of the cord is then taken down through the chassis, round the driving spindle, and brought up and knotted, the cord being drawn tight so that the spring is under tension.

The dial plate is bolted to the front of the chassis. If the card dial is used this is glued or taped to the dial plate; if not, a suitable piece of plain cardboard should be fixed in this position. The pointer is then fitted, the end of the condenser spindle being tapped 6 B.A. for this purpose. The two 50 μ F trimmers are bolted to the rear of the gang condenser. Long bolts should not be used or these will foul the plates of the condenser.

Sub-chassis Wiring Points.—Although all connections are shown in the diagrams a few items require special mention. First, care should be taken that the bias condenser is not shorted to the chassis. The positive tag of this condenser is wired to chassis and if a metal-cased component is used the casing will be common to the negative tag. Such a condenser should accordingly be wrapped in tape or other insulating material. If this condenser is shorted volume will be reduced and H.T. consumption increased, due to the failure of the auto-bias circuit.

All other connections should be insulated; 20 S.W.G. tinned copper wire is convenient to use and solder. A short length of twin flex is taken from anode and screen-grid tags of the output valveholder, for subsequent connection to the primary of the speaker matching transformer. The battery leads are of flex cut to a suitable length. H.T. and L.T. leads must on no account be confused.

The coil wiring will become clear from the diagrams. Each coil is already fitted with a stout bare wire; this is bolted to the chassis and supports the coil, also forming one connection. It is recommended that the specified coils be used. Other coils may have the tags in different positions, or have windings of unsuitable type. Though some space remains above the chassis the H.F. coil must not be fitted here, or instability will arise.

The switch wiring is very straightforward. In the "Off" position no circuit is completed. In the "Medium Wave" position both coils are switched to medium waves and the

L.T. circuit completed. In the "Long-Wave" position the L.T. circuit only is completed.

Wiring should be reasonably short and direct. The lead from the $\cdot 0002 \mu\text{F}$ aerial condenser (marked X) should be kept well away from the H.F. coil and detector stage wiring generally. A lead from this point also passes through the chassis to the aerial coil. Other leads can conveniently be taken up through the holes drilled for the driving cord.

Operating Instructions.—Though little difficulty is likely to arise it is felt that the constructor would like a few details of operation. Wiring should be checked before inserting the valves and connecting the batteries. A H.T. voltage of up to 90 may be used. For L.T., any 1.5-volt dry battery can

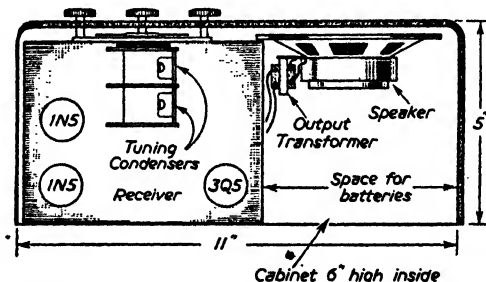

FIG. 125.—Layout of Receiver and Speaker in Cabinet.

be used. If this battery has more than one cell, all the cells must be wired in parallel. A combined H.T. and L.T. battery can be used, or separate batteries.

A moving-coil speaker is recommended; this *must* be of the permanent magnet type, and have a matching transformer for battery pentode (8,000 ohms). A transformer matched for a mains-type pentode is not suitable. If odd speakers and output transformers are to hand, assure that the secondary impedance of the transformer is suitable for the speech-coil impedance of the speaker. If this is not correct, distortion will arise and volume will be reduced. (These items will be correct if the specified speaker and output transformer are obtained, but there is, of course, no reason why speakers of other manufacture should not provide satisfactory results.)

With aerial and earth connected, the local stations should

be received immediately. The trimmers may then be adjusted for maximum volume, selecting a weak station of fairly low wavelength in the M.W. band. As the trimmers are adjusted slight re-tuning with the control knob will be required. When no further adjustment of control knob or either trimmer improves volume, then trimming is correct.

With care, a reasonably accurate pointer indication can be obtained throughout the range. The pointer may require turning a little, the screw being loosened. If the dial indication is progressively too low near the lower wavelength end of the scale, then both trimmers should be unscrewed a little. If the pointer indicates wavelengths higher than those actually tuned, at the low-wavelength end of the scale, the trimmers should be screwed down. These adjustments will make little difference at the other end of the scale.

Alignment is not much influenced by the type of aerial, as aerial coupling is by means of a primary winding. However, weak stations will only be received at best volume when the trimming is correct.

Cabinet Details.—Best quality and volume will only be obtained when the speaker is enclosed in a cabinet, and a pressed bakelite cabinet in a variety of colours is available, so that the completed receiver can have a finish equal to that of a commercially manufactured set. Alternatively, a simple type of cabinet could be made, using $\frac{1}{4}$ -in. wood for top, bottom, and sides, with three-ply for the front. As an aid in this direction, cabinet dimensions are given. From reference to these it would be feasible to construct a cabinet, as mentioned.

If the ready-made cabinet is employed, then a small baffle of three-ply about 5 in. square should be cut to support the speaker. Sufficient space has been left for batteries of small type; full-sized batteries cannot be accommodated. If they are to be used, then the battery leads should be extended and the batteries placed outside the cabinet, behind.

Aerial System.—An efficient indoor aerial can be made from a length of any thin insulated wire. This may be placed round the picture rail, or suspended along the walls. Thin, plastic-covered wire (consisting of one strand of 22 S.W.G.), or any similar conductor can be used, and a colour to match the walls may be selected. For maximum signal pick-up the wire should be as long as possible, but it should not be continued round more than two walls, or looped back on itself. In many cases a few feet of wire along one wall may be

sufficient, but range will then naturally be reduced. With the original receiver, a few feet of wire was found to give ample volume from the local stations. However, reception conditions vary throughout the country.

Best long-distance reception was naturally obtained by using an outdoor aerial. This was 50 ft. of 7/22 S.W.G. copper wire, forming aerial proper and lead-in. Such an aerial should be as high as possible, and well clear of walls and earthed objects. With it, the local stations were received at such strength that the output stage was overloaded at

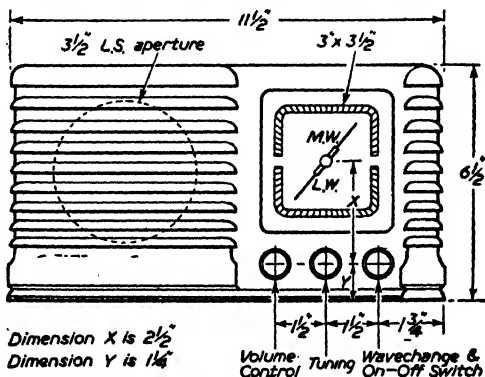

FIG. 126.—Front Dimensions of the Cabinet.

maximum volume. (Such over-loading, and consequent distortion, is normally prevented by turning the volume control down, of course.) A considerable number of foreign stations were also received.

In each case adding an earth gave a further increase in range. Such an earth is best provided by taking a lead directly to an earthing spike or other metal object buried in damp soil.

COMPONENT LIST

Dual-wave aerial and H.F. coils with reaction. (T. G. Howell.)
 2-gang .0005 μ F. tuning condenser with tapped spindle and pointer.
 2 50-pF. trimmers.
 450 ohm, .25 megohm, .5 megohm, 2 megohm, and 2.2 megohm, $\frac{1}{4}$ -watt resistors.
 50 pF., 2 .0002 μ F., .001 μ F., 2 0.1 μ F., .1 μ F., and 12 μ F., 12-volt fixed condensers.

- 3-pole 3-way rotary switch. (Coventry Radio, etc.)
- Dial and drive assembly, complete, with 2-in. drum. (Sussex Electronics.)
- 3 1½-in. diameter brown knobs. (Sussex Electronics.)
- 20,000-ohm potentiometer.
- 3 octal valveholders. 2 1N5 and 3Q5 valves.
- Stentorian 3½-in. speaker with Miniature Service Output Transformer (60-1 ratio).
- Brown or ivory bakelite cabinet, or wooden ditto. (Sussex Electronics.)
- Aerial and earth sockets, nuts and bolts, connecting wire, etc.

Circuit No. 65.—This three-speed Autogram has been designed in such a manner that it may be included in an existing cabinet. The main amplifier with the power-pack is built as a separate unit and is attached to the floor of the cabinet, whilst a modern Ediswan-Plessey auto-changer is fitted on to the motor-board.

Several features were considered in designing this receiver, mainly accessibility and interchangeability, so that if at any future date it is desired to make changes in any part of the equipment no difficulty should be experienced. Furthermore, it may be desired by some to construct the receiver from the first in an alternative form, and the design lends itself very well to this.

Main Features.—Taking first the main features (as distinct from the circuitry), the equipment is in three separate sections, interconnected by plugs and sockets. The motor-board, with auto-changing mechanism, will take a stack of eight records, 10-in. and 12-in. mixed, at 78 r.p.m.; a stack of ten records, 10-in. and 12-in. mixed, at 33½ r.p.m.; and a stack of eight records, 7-in., at 45 r.p.m. This particular unit employs a single pick-up head which may be set with the aid of a small knob to suit whatever type of record is to be played. The point is of the "permanent" type and should play a total of 4,000 records without replacement. Any desired record may be rejected, and the mechanism works very well indeed. Power from the mains for the turntable is obtained from a short lead plugged into a mains socket on the receiver/pre-amp. chassis, and this is so connected that the motor is only "live" when the receiver is switched on. There is thus no risk of the motor being left running with undue wear on the stylus unless the set is being listened to. Screened leads are taken to the pick-up sockets at the rear of the chassis, and these, as will be seen from the circuit (Fig. 127) are fed to a separate single-stage

there is insufficient L.F. gain in the combination to give adequate signals on weak stations. This criticism can be upheld, but must be considered against the question of quality of reproduction, which is usually poor when a weak station is received, either because of the low signal-to-noise ratio or because of interference. As there is thus very little entertainment value in such a signal, it is not worth while

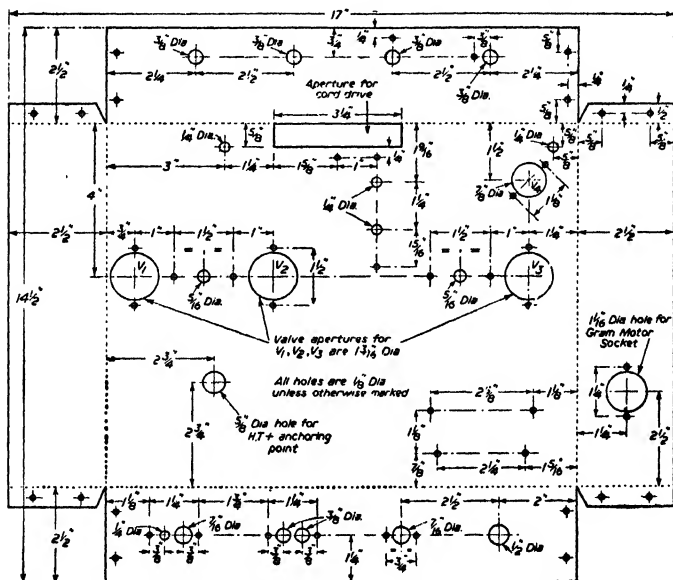

FIG. 129.—Drilling details for the Tuner and Pre-Amplifier Chassis.

providing additional gain, but at a later date it is quite a simple matter to include a further stage before V5, and it will be noted that space has been left on the amplifier chassis for this purpose. Such a stage is quite critical, however, and there are a number of considerations which must be borne in mind. Firstly, it will follow the gramophone amplifier, and this means that records will be reproduced very much more loudly. It may easily then be possible to overload the output stage. Secondly, any distortion introduced in the new stage will be heard on records also, and it would not be

practicable to include the gramophone pre-amplifier between the new stage and V5. We tried the circuit in this connection and using a 6BR7 with components to give a very low-stage gain, obtained some improvement on the weaker stations, but generally the difference on records and the main entertainment stations was such that it was not considered worth while to fit it.

Constructional Work.—As already mentioned, the main tuner is built on a baseboard of the metal-covered type, merely because this particular old receiver had that type of construction, but the layout was so arranged that the rear runner may be considered, with a similar runner in the front, as the sides of a standard chassis, measuring 12 in. by $9\frac{1}{2}$ in. by $2\frac{1}{2}$ in. deep, and this is the arrangement which is specified. The shelf to accommodate such a chassis must be so positioned that the large full-vision dial assembly will not foul the motor-board, and this will call for individual attention according to the type of cabinet being used. The chassis for the main amplifier measures 15 in. by 8 in. and is also $2\frac{1}{2}$ in. deep, and this will have to have cut-outs in it to clear the terminals of the mains transformer and chokes. Details of these are given on the full-size blueprint.

The mains socket for the gramophone motor will, of course, be mounted on the side of the chassis if this method of construction is adopted, and there is no reason why it should not be placed at the opposite end of the chassis if desired. The main interconnecting cable may be constructed from standard coloured plastic-covered flex to facilitate identification, and the two theoretical circuits show the plugs and sockets in standard theoretical form with the numbers as carried on the Bulgin octal plug—which are, of course, the standard B.V.A. markings for octal valveholders. When the cable has been constructed and the socket wired a special check should be carried out, as it is easy to introduce a short-circuit in this part of the operation, and should this be across the mains leads a nasty accident may occur.

Once again it should be pointed out that the particular items specified in the list of components are those which we actually used in the prototype receiver, and this does not mean alternatives cannot be used.

The first part of the constructional work consists of chassis making, and as already explained, there are two alternatives for the tuner and pre-amplifier unit. In the prototype this unit was made on a baseboard so that it could be slid into

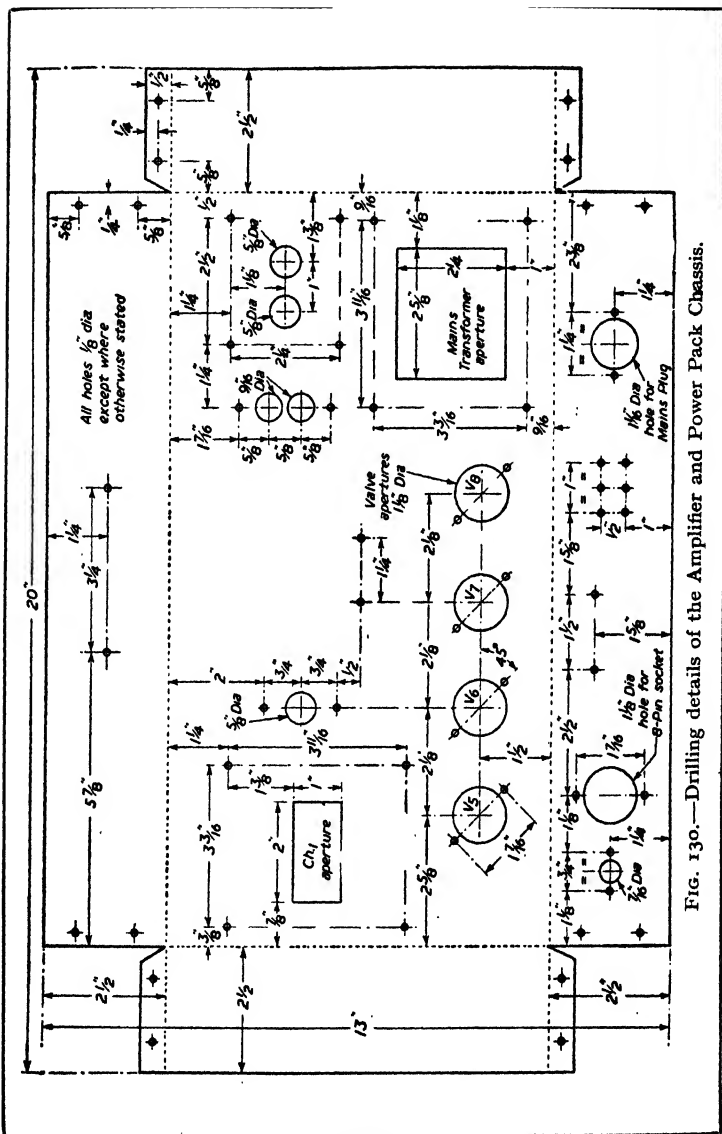

FIG. 130.—Drilling details of the Amplifier and Power Pack Chassis.

the cabinet in place of a shelf which was originally there. It will be noted, however, that a strip of aluminium was fitted to the front and rear in the same manner as with a standard chassis, to accommodate controls and socket strips, and the layout was kept within the bounds of these strips so that exactly the same layout could be adopted on a standard type of chassis. In the original the wooden shelf was of metal-covered plywood, but it will be assumed that in the majority of cases a standard chassis will be used and placed upon a shelf or even suspended from the motor-board where a wide type of up-to-date cabinet is employed.

Full details of the chassis for the tuner are shown in Fig. 129. A sheet of stout gauge aluminium 17 in. by $14\frac{1}{2}$ in. will be required and it should be cut out round the edges, as shown, the drilling holes for the corners being very carefully marked out to ensure accurate registration. These corners may be either riveted or fitted with nuts and bolts. To accommodate the cord drive for the tuning dial a rectangular opening is required, and this must be carefully positioned to avoid the cord catching on the edges of the chassis.

Chassis Cutting.—Many constructors find difficulty in carrying out a professional-looking chassis constructional task. It is desirable so far as possible to do all drilling and cutting whilst the chassis is in a flat state. It can be supported more easily in this way and both sides of the chassis may be used as a working surface. Drill small pilot holes before cutting the large valveholder holes, and open these with a disc cutter. Cut through until the edges show on the reverse side and then turn over the chassis and complete the work from the opposite side. In this way a clean hole will be obtained without a rising burr which will afterwards have to be removed. Note that all holes which are not marked on the chassis with a size are of $\frac{1}{8}$ -in. diameter.

The H.T. positive anchoring point in this case was drilled to $\frac{1}{8}$ in. and an insulating washer was inserted to carry a short stand-off pillar on the underside. In place of this, if the constructor desires, a single insulated mounting tag may be used and screwed to the underside, but make quite certain that there is adequate clearance between the "live" tag and the chassis. When all holes have been drilled and the edges cleaned up as necessary the sides of the chassis must be bent over. There is no doubt that the most satisfactory way of accomplishing this is to use a good metal bender, made up either of 1-in. square iron bars held with bolts at

either end, or by clamping a stout wooden board on the bench and sliding the runner part of the chassis under this. For sharp, clean edges the metal clamp is to be preferred, and for the sides a strip of stout timber must be cut to exact dimensions to clear the ends already bent over. The small turned-in edges which clamp the side and end runners together may be bent over by holding in a bench vice.

Amplifier Chassis.—The chassis for the amplifier calls for a little more work, as the mains transformer and chokes which are specified are intended for mounting with the soldering lugs projecting below the chassis. This provides better screening and also reduces the length of connecting leads. For the chokes it is possible to make do with two holes for each or to cut a rectangular slot. Both arrangements are indicated on the chassis details shown in Fig. 130 and it is left to the constructor to adopt whichever he finds easier. For the mains transformer, however, in view of the number of connections which have to be made, a rectangular hole is essential. The simplest way of cutting this is to mark it out carefully, and then to drill all round just inside the edge of the line with $\frac{1}{8}$ -in. drill. If an electric drill is being used this will not take long. A cold chisel may then be used to cut between adjacent holes and the ragged edge afterwards cleaned up with a file. As an alternative, a single hole ($\frac{1}{8}$ in.) may be drilled exactly in each corner of the opening and cuts made along each edge from hole to hole with an abrasive hacksaw blade. There are no other difficult points on this chassis, and the cutting and bending should proceed exactly as in the case of the tuner chassis.

Component Mounting.—Before wiring, all parts have to be mounted, and again it is desirable to proceed according to your particular ability. Some constructors prefer to mount everything in its place and then to wire up, while others prefer to mount only the valveholders and very small items first, wire these up, and then add the bulkier parts gradually. This does make the chassis easier to handle, but whatever system is adopted, systematic wiring is essential to avoid leaving out or wrongly connecting important leads.

Component Wiring.—The electrolytic condensers must be connected with the correct polarity. The small .1 condensers which are specified for this receiver, and many others which are available, carry a black ring round one end of the condenser casing, and this denotes that the connecting lead at that end of the condenser is joined to the outer foil. This

does not have to be earthed, except where it is placed in such a position that one side of that particular condenser is connected to earth. It should, however, be connected to the "cold" side of a circuit, that is, the "earthy" side of a circuit. For instance, if such a condenser were used as a L.F. coupling condenser the outside foil would be joined to

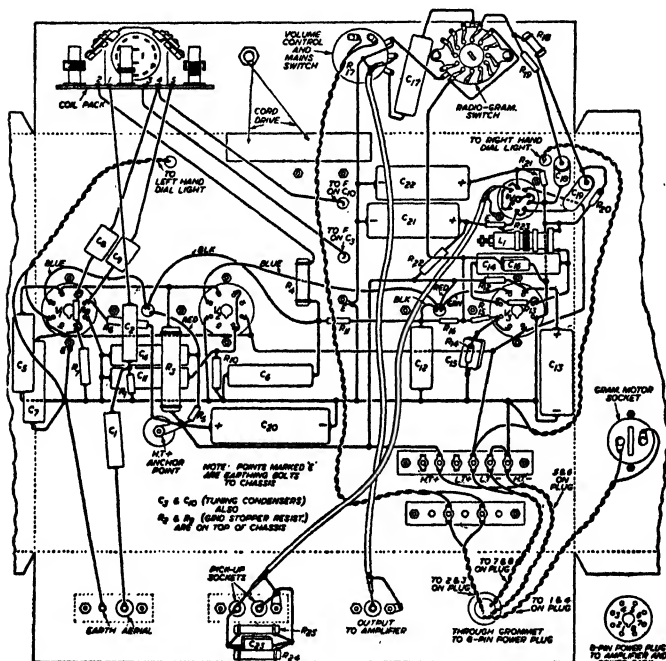

FIG. 131.—Wiring Diagram of the Tuner and Pre-Amplifier.

the grid of the valve, and the other side to the anode of the preceding valve. Where the condensers are used for decoupling, however, the outside foil connecting lead is taken direct to earth.

Many of the resistors will be found to have leads sufficiently long to enable a portion to be cut off so that they may be connected from point to point without adding any leads. They will be sufficiently rigid to avoid the necessity

for using screened sleeving unless it is required to make the wiring look "pretty," but except where long leads pass close together and there is a risk of sagging with resulting short-circuits, sleeving is not really a necessity. Many constructors, again, use coloured sleeving to identify various parts of a circuit—red for H.T. carrying leads, black for "earthy" leads and so on.

Connecting Plug and Socket.—When making connections to the multi-point connecting plug and to the strips on the tuner chassis, use red and black flex to ensure that no possible cross-over arises with disastrous results when the two chassis are interconnected. Preferably use rubber-covered flex for the L.T. and plastic-covered for the H.T. The mains leads may be cotton-covered over plastic or similarly identified. Furthermore, when this part of the wiring has been completed make a cross-check by connecting a battery or meter to each end of the separate leads, as it is fairly simple to go wrong and cross over when dealing with eight separate leads, and as the mains supply leads are included the result of a mistake may be quite expensive.

There is only one more point which may be mentioned on the constructional side, and that concerns the radiogram switch. This is actually of the two-pole change-over type, and there are a number of alternative types which may be used. As will be seen from the blueprint, a Yaxley wafer is used as it lends itself to the use of two poles with two positions. Bulgin make a rotary change-over switch which may be used, although it has a short spindle and will call for the use of a connector or some means of extending the spindle so that it lines up with the other controls on the panel.

Having completed the wiring and tested the multi-cord lead, the receiver is now ready for testing, and this should be carried out before inserting the apparatus in the cabinet so that any necessary modifications may be more easily carried out. Make certain that the fuses are correctly fitted and of the right type, turn the volume control to its maximum position anti-clockwise until it clicks, and then insert the mains plug into a convenient mains socket. The valves should be inserted into the sockets as indicated on the chassis layout, in conjunction with the theoretical circuit, in which the valves are numbered as well as indicated by their type numbers. For the time being leave the gramophone motor mains plug out of the socket on the main chassis and ignore the pick-up leads. Plug in a short length of wire (about 10

or 15ft. of any kind of wire will do) and connect a lead from the earth socket to a good earth connection. For preference, and to improve signal strength and reduce hum, this lead should be taken to a really reliable earth, preferably a spike or metal sheet buried in the ground. Too little importance is often attached to the earth lead, but it plays quite a large part in obtaining "clean" signals, and it should be remembered that it is actually part of the first tuned circuit, which consists of the aerial and the associated coil.

Linig-up.—Screw a dial light into each of the holders on the dial and clip the holders into their position, and switch on the mains socket. Now turn the volume control clockwise until it clicks and then leave the control at that position. This indicates that the on/off switch has operated and the volume control is at the position of minimum volume. The dial lights should light up as soon as the click is heard, and after a few seconds a breathing sound should be heard from the speaker. No hum or crackling, etc., should be heard, and if they are, it will be as well to switch off and switch off the mains supply whilst a further inspection is made of the wiring, firmness of the valves in their holders, etc. When switched on with the volume control at minimum there should be great difficulty in hearing any sound from the speaker other than a faint liveliness which can only be described as a breathing sound. Provided this stage has been satisfactorily reached the radiogram switch should be operated and a click should be heard in the speaker as it is turned from one position to the other.

The pick-up circuit is completed by the parallel resistor, so no hum will be heard when turned to gram, and if you are not certain which is the radio position and which gram you will have to rely upon a signal being tuned in, but an inspection of the wiring will show that, if similar connections are followed with the particular switch you have obtained, radio will be heard when the switch is turned anti-clockwise and gramophone when turned clockwise. Turn up the volume slowly and note the increase in background noises. On gramophone there will be no effect other than a slight increase in the breathing sound, so if no general crackling and similar noises are heard when the volume control is at maximum, turn back to minimum and operate the radiogram switch. Turn the control about half-way on and then tune through the dial with the wave-change switch set to its central position, which is the medium waveband setting.

FIG. 132.—Wiring Diagram of the Power Pack and Amplifier.

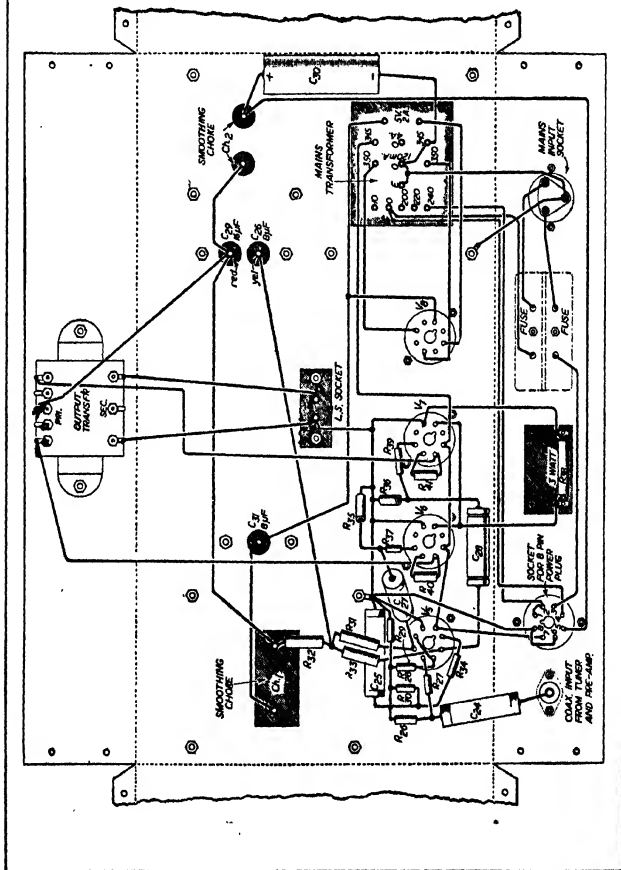

The local station should be received, although perhaps very distorted as the circuits will require lining up.

Adjusting the Coils.—As sent out, the I.F. transformers and the coil pack are pre-set to approximately the correct positions, and it is quite possible to find that the stray capacities introduced by the wiring are so small that really good results are obtained immediately and very little re-adjustment is required, but we will assume that due to transit vibrations, etc., the adjustments are well out. Turning through the tuning range will then result in no signals being heard, other, perhaps, than a whistle or two or perhaps some code signal. In this case, remove the aerial lead and connect it by means of a clip to terminal 4 on the coil unit. Turning the dial now should enable at least one station to be picked up, and as soon as it is located turn down the volume until it can only just be heard. Now very carefully, with a sharpened knitting needle or wooden screwdriver, turn the screws of the I.F. transformers. Do this very carefully, and note the original settings so that if no improvement is effected the original setting may be obtained again. All four adjustments should be made in this way and they should, of course, all be adjusted for maximum volume, any improvement being counterbalanced by reducing the volume, so that at all times the signal is kept as weak as possible.

Peaking the Coils.—Having lined up the I.F. transformers, the coils must now be correctly aligned so that the tuning indicator is correct throughout the dial, and it should be remembered that the coils are provided with iron cores as well as padding or trimming condensers. The core adjustments affect the low-frequency end of the tuning scale, whilst the trimming condensers affect the H.F. end, and the two adjustments must be made correctly or the scale will be found out at one end or the other. The makers' instructions regarding the lining-up cannot be improved upon, and in conjunction with Fig. 133, they are as follows:

Medium Wave (190–520 metres).—1. Tighten trimmers C₁ and C₂ (taking care not to crack the ceramic washers), then loosen half a turn.

2. Switch to M.W. and set pointer at 98 deg. Tune in Home (330 metres), by adjusting core of L₁ (M.W. oscillator).

3. Adjust core of L₂ (M.W. aerial) for maximum output.

4. If the I.F.s have not already been peaked at 465 kc/s, they should now be tuned for maximum.

5. Set pointer at 140 deg. and tune in the Light pro-

gramme (247·1 metres) by adjusting C₂ (oscillator trimmer). Adjust C₁ (aerial trimmer) for maximum.

6. Set pointer at 47 deg. and tune in North Regional (434 metres) by adjusting core of L₁ again. Tune core of L₂ for maximum.

7. Repeat 5 and 6 several times until the positioning and strength of these stations become constant.

8. Make a final adjustment of L₂ on any *weak* station around 30 deg. Make a final adjustment of C₁ on any *weak* station around 160 deg.

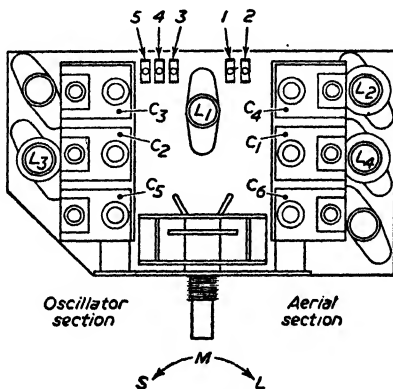

FIG. 133.—Details of the Coil Trimmers.

Long Wave (800–2,000 metres).—1. Switching to L.W. (turn knobs clockwise), set trimmers C₃ and C₄ as in No. 1 above.

2. Set pointer at 69 deg. and tune in the Light programme (1,500 metres), by adjusting core of L₃ (L.W. oscillator).

3. Adjust core of L₄ (L.W. aerial) for maximum.

4. Tune in any station around 120 deg. and tune C₄ (aerial trimmer) for maximum.

Short Waves (15–50 metres).—Without a signal-generator, little can be done to align the S.W. coils accurately, and it is advisable not to alter the position of the cores. The oscillator is designed to work at a frequency 465 kc/s above that of the signal being received. Both C₅ and C₆ (oscillator and aerial trimmers) should be half-opened. A signal may be tuned in around 160 deg. and C₆ adjusted for maximum. (The leads

from the coil-pack to the frequency-changer should be as short as possible, in order to obtain best results on S.W.)

Using a Signal Generator.—Where a signal generator is used, the tracking points and frequencies are as follows :

L.W.	29 deg.	1,800 metres	166.7 kc/s.
L.W.	140 "	1,000 "	300 kc/s.
M.W.	37 "	450 "	666.7 kc/s.
M.W.	138 "	250 "	1,200 kc/s.
S.W.	32 "	45 "	6.667 m/c.
S.W.	149 "	20 "	15 m/c.
Trawler-band	32 "	210 "	1,429 kc/s.
Trawler-band	143 "	110 "	2,727.3 kc/s. (approx.)

When the specified Glass Dial Assembly is used, all the stations should come into line, once the preceding instructions have been properly carried out. If they do not do so, within reasonable limits, it may be because the wrong type of tuning-condenser is used. This should be the usual type of .0005 μ F. twin-gang, maximum capacity (vanes closed) when spindle turned fully clockwise.

Gramophone.—When the tuning has been satisfactorily carried out, a wide range of stations should be heard at very good quality. Obviously the better and higher the aerial the wider the range of the receiver, but good results on a reasonable selection of stations will be obtained even with a short length of wire attached to the aerial socket. To reproduce records all that is necessary is to plug in the mains lead from the gramophone motor, plus two leads from the pick-up into the pick-up sockets and place a suitable record on the turntable. The motor has an adjustable head and switch for the type of record being played, and the switch and pick-up head should be set correctly. Pressing the start button will set the motor in action and the pick-up will automatically be lowered and the radio/gram switch should be turned to gram when the signals will be heard. The volume control has about the same variation as on a good local station signal, and it should be possible to turn the control to full on any record without overloading or distortion. It should be noted that no damage can occur to the delicate pick-up head by inadvertently pressing the start button if the receiver is not switched on, as the on/off switch also controls the gramophone motor, and if the set is switched off the motor also is off:

(BLUEPRINT AVAILABLE)

COMPONENTS FOR TUNER AND PRE-AMP

- 1 type H.O. coil pack. Osmor.
- 1 2-gang .0005 μ F variable condenser. J.B.
- 2 I.F. transformers, 465 kc/s. } Denco.
- 2 maxi-" Q " coils, range 1 (Blue) }
- 1 type " A " glass dial assembly and associated drive, pulleys, etc. Osmor.
- 1 250 K Ω volume control with S/P switch (type C). Dubilier.
- 1 rotary 1-pole 2-way switch.

Condensers

- 1 100 pF (mica) }
- 1 200 pF (mica) } Type CM20N. T.C.C.
- 3 500 pF (mica) }
- 2 .01 μ F, type 543 (500 v.w.) }
- 2 .05 μ F, type 543 (500 v.w.) } T.C.C.
- 7 .1 μ F, type 543 (500 v.w.) }
- 1 .1 μ F, type CE37N (500 v.w.) }
- 2 8 μ F, type BR850 } Dubilier.
- 1 16 μ F, type BR 1650 }
- 1 25 μ F, type CE32C. T.C.C.

Resistors

- 4 220 Ω }
- 1 1 K Ω } 2 68 K Ω
- 1 4.7 K Ω } 3 100 K Ω
- 5 10 K Ω } 1 150 K Ω
- 1 33 K Ω } 1 500 K Ω * } $\frac{1}{2}$ w. Dubilier.
- 1 47 K Ω } 1 1 M Ω
- 1 47 K Ω 1 w. 1 47 K Ω 2 w. Erie. } * See Text
- 1 I.O. valveholder } Clix.
- 1 B9A valveholder }
- 1 2-pin plug and socket (P350) }
- 1 5-way tag strip (T24) } Bulgin.
- 1 2-way tag strip (T17) }
- 1 1-way tag strip (T32) }
- 1 A.E. socket strip and plugs } Stern's Radio.
- 1 P.U. socket strip and plugs }
- 1 rubber grommet ($\frac{3}{8}$ in.). }
- 1 coax. socket and plug (L604/2 and L734/P). Belling & Lee.

Four control knobs. Bulgin.

Metal chassis, 12 in. \times 9½ in. \times 2½ in.; bolts and nuts; insulated connecting wire; 2 6.3 v. dial lights, 1 yd. 75Ω coaxial lead. Stern's radio.

1 6K8 valve. 1 6SN7 valve }
1 6K7 valve. 1 6BR7 valve } Brimar.

COMPONENTS FOR AMPLIFIER

1 type PTM13A mains transformer }
1 type PCF18 L.F. choke (Ch. 1) } Woden.
1 type PCF17 L.F. choke (Ch. 2) }

Condensers

3 ·1 type CP37N (350 v.w.) }
1 ·1 type 543 (500 v.w.) } T.C.C.
1 8 μF type CE25P (450 v.w.) }
1 16+8 μF type CE28P (450 v.w.) }
1 32 μF type BR3250. Dubilier.

Resistors

2 100 Ω
1 1 KΩ
1 10 KΩ
4 47 KΩ } ½ w
2 220 KΩ } Dubilier.
1 1 MΩ
1 10 KΩ
2 33 KΩ } 1 w
1 240 Ω, 3 w. Welwyn.
1 plug and socket (L604/2 and L734/P). Belling & Lee.
5 I.O. valveholders. Clix.
1 3-pin mains plug and socket (P 162).
1 fuseholder (type F141) and fuses (1 amp.) } Bulgin.
1 8-pin plug (type P112)
1 6SN7 valve }
2 6V6 valves } Brimar.
1 5Z4 valve }
1 W.B. 10-in. Stentorian L.S. and transformer. Whiteley Electrical.
1 miniature 2-pin plug and socket. Clix.
Metal chassis, 15 in. \times 8 in. \times 2½ in. Insulated Connecting wire, bolts and nuts. Stern's Radio.
1 multi-speed auto record changer. Ediswan-Plessey.

Circuit No. 66.—This four-valve receiver is, in effect, a miniaturised version of any standard type of portable, the front panel carrying the loud-speaker and controls, and the main components, valves, etc., being mounted on a shelf. The combined battery fits at the back behind the loud-speaker and the whole drops into the carrying case which is available from J. Tallon & Sons of Rugby.

The Circuit.—As will be seen from Fig. 135, the circuit is a four-valve combination incorporating the superhet principle. The circuit provides a frequency-changer, I.F. stage, diode rectifier, L.F. amplifier and pentode output. The valves are of the B7G midget type selected from the Mullard range, and the I.F. transformers are the latest midgets in the Wearite range, with both windings tuned. The heart of any receiver is the tuning circuit, and in this model we have chosen the new midget coil turret supplied by Stern Radio. This is a miniature rotary unit carrying aerial and oscillator coils, and designed for pre-set tuning of four stations. Each coil is of the iron-cored type and the coils are mounted on a rotating plate which wipes over four contacts. Thus only four connections have to be made to the unit, and rotation of the control knob brings each coil into circuit successively. The inductances are so chosen that one can select three stations from the medium waveband and one from the long waves, and the actual stations chosen will, of course, depend upon the locality.

A measure of A.V.C. is incorporated in the circuit, and this is very effective, as will be found if a length of wire is attached to the aerial terminal on the coil unit. With a short length of wire, in the London area the local station can be tuned in, and any increase in the length of the wire, or gripping of the end of the wire, does not result in any noticeable increase in strength. I.F. filtering is simple but complete, and the circuit is quite stable when the I.F.s are properly adjusted.

The loud-speaker fitted is a $3\frac{1}{2}$ -in. unit from the W.B. range, which gives a reasonable quality of reproduction, bearing in mind the size of the receiver. Some midgets are fitted with a 2-in. speaker unit, but we considered that it was worth while to use a larger unit, so that a reasonable volume could be obtained on musical items without that thin, high-pitched tone usually given by midgets. A simple tone-controlling device is fitted to lower the pitch slightly. Finally, it has been thought worth while to fit an electrolytic

smoothing condenser across the H.T. supply, and as a result the receiver conforms almost to normal full-size broadcast receiver practice. As already pointed out, however, this type of receiver is really only intended for intermittent use, and the battery specified will give roughly 30 hours' use if used regularly for about 20 minutes a day. Obviously if not

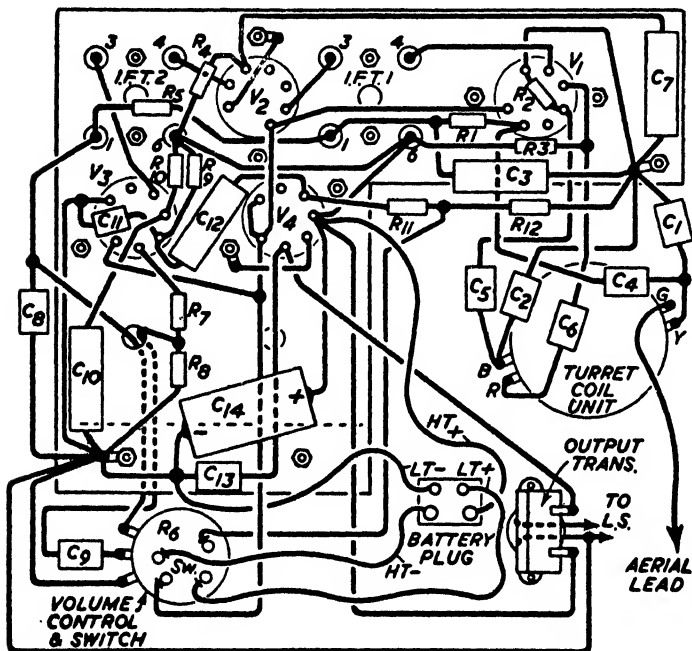

Fig. 134.—Wiring Plan of Circuit No. 66.

used so often the battery will last longer, but this particular battery should not be used if it is required to listen to, say, a complete programme of one hour's duration. For those who require a small set of this type for use under these conditions it would be preferable to house the actual receiver in a larger cabinet, and then to use separate L.T. and H.T. batteries, selecting these from the larger capacity ranges. There is then no reason why the receiver should not be

photographic illustrations and in one or two places where the wires pass close together as they may get pushed into contact when changing the battery. The various illustrations will show where the different condensers are tucked away, and when the chassis itself has been wired the speaker and transformer, the coil unit and the volume control should be mounted on the front panel. Wire the transformer to the speech coil and then bolt up the chassis and complete the wiring. Note that the tag on the right-hand side of the panel

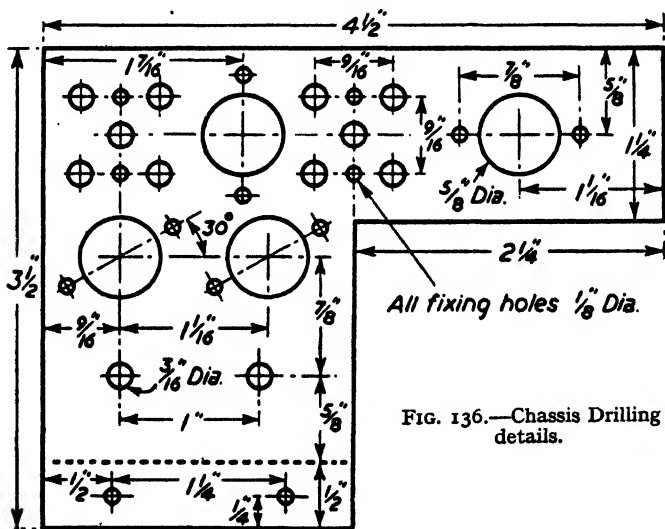

FIG. 136.—Chassis Drilling details.

(viewed from the back of the receiver) is used only as a common anchoring point for certain "earth" leads, and nothing is bolted to this point. A standard soldering tag is locked under the nut, and the same method is used at the opposite end of the panel for the other "earth" point. If a really hot soldering iron is not available for use it will probably be found preferable to attach the earth points to the tag whilst this is held away from the panel in a small pair of pliers, as the surrounding metal will cool off the iron if this is of the small electrically heated type. No attempt should be made to make soldered connections by leaving the iron in contact with the point so as to heat up the surrounding metal, as

the condensers, etc., will be damaged by the excessive heat. Where two or more contacts are made to one point it is preferable to hold the contacts in position with a thin-nosed pair of pliers and solder them at one operation, rather than to attach them one at a time. This not only may result in the first contact coming away when the second is placed on, but the second application of heat may result in damage to the component.

Testing.—When the wiring is complete it should be carefully checked with the diagram, and, if possible, with the theoretical circuit. The I.F. transformers are supplied with all four circuits accurately tuned to 465 kc/s, but inter-circuit wiring will obviously upset the alignment slightly. If a signal generator is not available the best way of getting the circuits accurately aligned is to attach about 15 ft. or 20 ft. of thin single flex to the aerial contact on the coil unit (green). Incidentally, it will be found that the contacts on this unit are rather close together and to prevent them from being short-circuited against each other it is preferable to bend one up and its neighbour down, to ensure that they will remain clear of each other. With the aerial lead laid out turn the coil unit to one of the medium-wave settings—choosing that which covers the station nearest to you. To assist you in deciding which is the most suitable in your locality the following table gives the frequency coverage of each setting of the coil turret control knob.

Position 1 (maximum rotation anti-clockwise)—1000–1,620 kc/s.

Position 2—680–1,220 kc/s.

Position 3—568–850 kc/s.

Position 4 (maximum rotation clockwise)—150–280 kc/s (long waves).

Find the frequency of your local and set the coil unit to cover the band embracing that frequency. Switch on and turn up the volume to full and with a trimmer (preferably made from a plastic or bone knitting needle sharpened to a screwdriver point) adjust the oscillator core (lower hole). If nothing can be heard as the trimmer is turned through the coil (take care not to bring it out so that it is broken when the turret is rotated), remove the aerial lead from the green tag on the coil unit and attach it to the yellow tag. It should then be possible to hear even a very weak station.

You may find the station easily tunable with the temporary aerial lead attached to the yellow tag. If so, the aerial

should be taken back to the green tag. Now adjust the aerial trimmer (upper hole), until the station is at its maximum

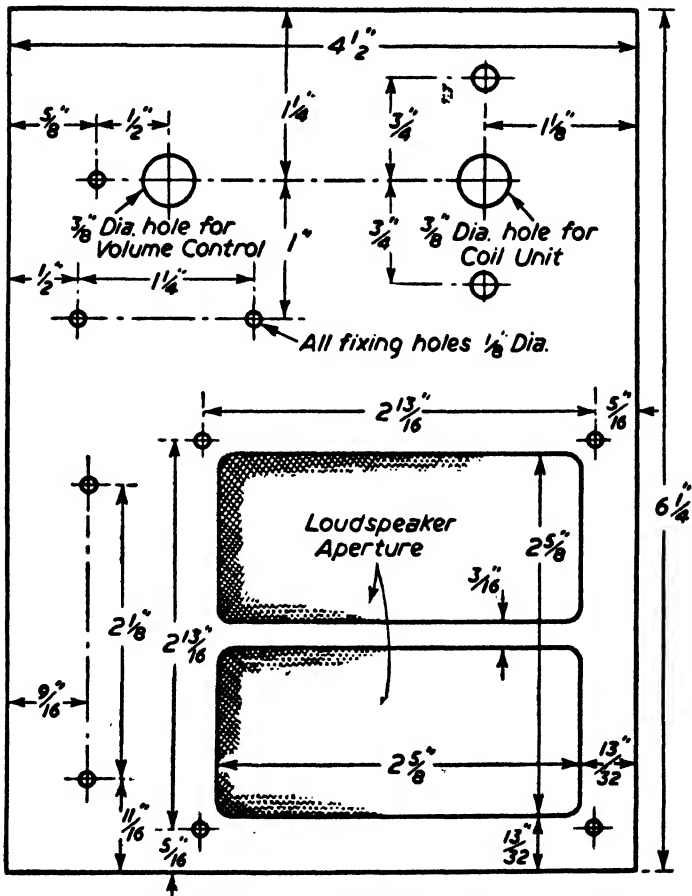

FIG. 137.—Method of marking out and Drilling the Panel.

volume, following this by a very careful adjustment of the I.F. trimmers for maximum volume. They should need only a very small movement, so do not turn them too far and then find that you are unable to obtain the original settings.

A slight adjustment of each, going from one to the other, should enable you to get the maximum performance, and then the other coils should be similarly aligned. This completes the tuning, and it should be found in most localities that the temporary aerial may be dispensed with and two or more stations may be tuned without any aerial lead—the coils themselves acting as small frame aeri-als.

In some localities, however, and perhaps in some types of buildings in good areas, it may be found that the actual signal available is too weak to provide a satisfactory signal and it will in such cases be necessary to use an aerial. This may take several forms and it will be necessary to adopt that type which the local conditions call for. In the extreme case of a very weak signal, up to 30 ft. of thin, flexible wire should be attached to the aerial tag (green). Take this through a small hole or gap cut in the back of the cabinet and drape this in the room—running it along the picture rail or perhaps just taking it up to a picture hook or nail, so that it has as much of a long, straight run as possible. In some cases it may be possible to coil up the wire so that only a foot or two is outside the cabinet, the coil also acting as a frame aerial.

Carrying this idea still further, the wire may be wrapped round the entire receiver and battery for two or three turns, and left inside the cabinet. For this arrangement the best idea is to cut two strips of cardboard slightly less than 6 in. in length and to stand these up at the sides of the receiver in line with V₃ and V₄. Cut small slots at the top and bottom edges of the strips and wind the aerial round the receiver, allowing the wire to be held in the slots and thus giving a firm foundation for the frame thus wound. The end of the wire may be attached to the cardboard by means of a small piece of Scotch tape, and the receiver and battery, together with the aerial, may then be handled as a complete unit and easily inserted into or removed from the cabinet.

Controls.—The volume control is generally supplied with a spindle 3 in. or less in length, and this has to be cut down to match the coil turret spindle. To avoid damage to the control the *end* of the spindle (not the control itself) should be clamped in a vice and the spindle sawn off with a hacksaw to the required length, the control being held in the hand to avoid excessive vibration and to prevent it from falling when the spindle has been cut through. This might sound an unnecessary instruction, but we are informed by the manufacturers that they often receive complaints from

constructors who fail to appreciate that the component will be damaged if it is clamped in a vice, or that it is not a good thing for it to drop to a stone floor.

Earthing Tag.—In order to produce the wiring diagram as a complete illustration, it will have been noted on the blueprint that the coil turret has been taken off the front panel and the tag above it is shown as being on the actual chassis. It is, of course, attached to the front panel and its position is not critical. A hole to accommodate the fixing bolt may be drilled anywhere between the coil turret and the top of the loud-speaker, or if desired, the top fixing bolt of the loud-speaker may itself be used to accommodate the earthing tag, and this will avoid drilling a further hole.

In the case of some of the tubular condensers it will be found that there is either a black ring round the case towards one end, or the letters "O.F." are printed on one end. Both of these indications are that the outside foil is connected to the lead at that end of the condenser, and it is desirable that that lead should be connected to the "earthy" end of the circuit. The mica condensers do not, of course, have to be connected in any special manner, and neither do the fixed resistors.

(BLUEPRINT AVAILABLE)

COMPONENTS FOR THE FOUR-VALVE RECEIVER

- | | | |
|---|--|-------------|
| 5 | 100 μ F Type 635 250vW condenser. | } Dubilier. |
| 2 | 150 μ F Type 635 250vW condenser. | |
| 2 | 1000 μ F Type 635 250vW condenser. | |
| 1 | 0.01 μ F Type 460 250vW condenser. | |
| 3 | 1 μ F Type 410 250vW condenser. | |
| 1 | 8 μ F Type BR815 250vW electrolytic. | |
| 1 | 1000 Ω Type BTS $\frac{1}{2}$ W resistor | |
| 3 | 22K Ω Type BTS $\frac{1}{2}$ W resistor. | |
| 1 | 100K Ω Type BTS $\frac{1}{2}$ W resistor. | |
| 1 | 470K Ω Type BTS $\frac{1}{2}$ W resistor. | |
| 2 | 1M Ω Type BTS $\frac{1}{2}$ W resistor. | |
| 2 | 2.2M Ω Type BTS $\frac{1}{2}$ W resistor. | |
| 1 | 6.8M Ω Type BTS $\frac{1}{2}$ W resistor. | |
| 1 | 5M Ω Type C potentiometer with D.P. switch. | |
| 2 | Type 800 I.F. transformers (Wright & Wear). | |
| 1 | turret coil unit, Type CT9 (Stern Radio). | |
| 1 | combined H.T. and L.T. battery, Type B114 (Ever Ready Ltd.) | |
| 1 | 4-pin plug, Type 2745 (Cinch). | |
| 1 | B7G valveholders, Type 76/437 (Cinch). | |
| 4 | valves: Types DK91, DF91, DAF91 and DL92 (Mullard). | |
| 1 | 3 $\frac{1}{2}$ in. dia. loudspeaker, Type S3.57 with transformer, ratio 55 : 1 (Whiteley Electrical). | |
| 2 | control knobs (Bulgit). | |
- Also aluminium for chassis, wire sleeving, nuts, bolts, etc.

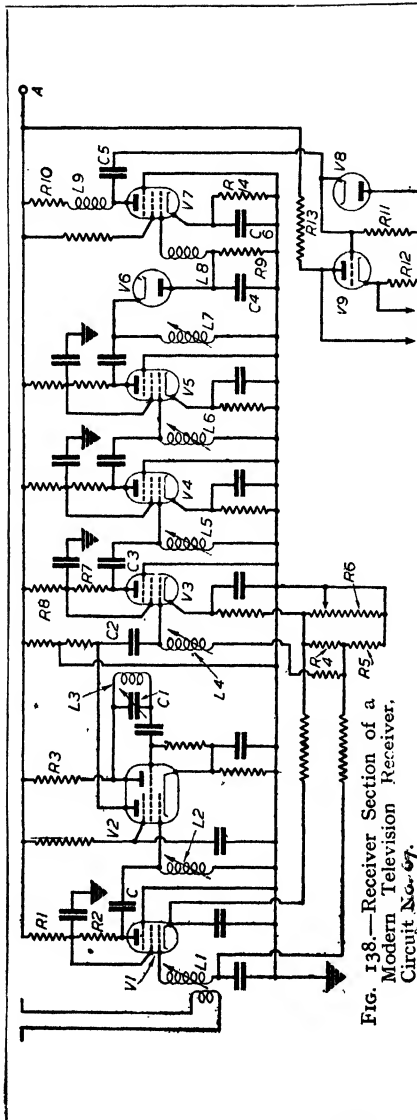

Fig. 138.—Receiver Section of a Modern Television Receiver.
Circuit No. 67.

The circuit shown above is the receiver portion of a modern television receiver. On the facing page is the circuit of the time-base, cathode-ray tube, and associated circuits. The sound portion of the receiver follows standard technique as described elsewhere in this book.

The vision receiver with few exceptions follows standard circuit design, the unmarked fixed condensers in the above circuit having a value of 0.01 μ F. for decoupling, and 0.002 μ F. for coupling. Valves may also be standard V.H.F. types, the frequency changer, for instance, being a triode-hexode such as the AC/TH1 or ECH33. The H.F. pentodes in the other stages may be EF.50's or Z.62's. Standard acorn or similar valves may be used for the diodes—EA.50's are very suitable. Coils may be standard commercial components or home-made. In the latter case $\frac{1}{2}$ -in. diameter paxolin tubing may be used and either brass or copper slugs, or powder-iron cores used for tuning. Standard formers and slugs are available for the purpose.

Great attention has to be paid to the lay-out of the vision receiver, as no trace of instability must be permitted. Adequate screening, short earth leads, and the avoidance of earth "loops" in the wiring must be avoided. Setting up of the receiver is simplified if a signal generator and output meter, or better still an oscillograph are available, but it may be satisfactorily carried out, if the special morning trade transmissions can be made use of.

The time-bases are more difficult to adjust, but again, are simplified if a generator and oscillograph are available. The special tuning signal, broadcast for one hour every morning is, however, invaluable in obtaining maximum band-width, and correct line and frame time-base adjustments.

In view of the fact that upwards of 2000 volts are available in the power pack and C.R. tube sections, the utmost care must be exercised in carrying out adjustments.

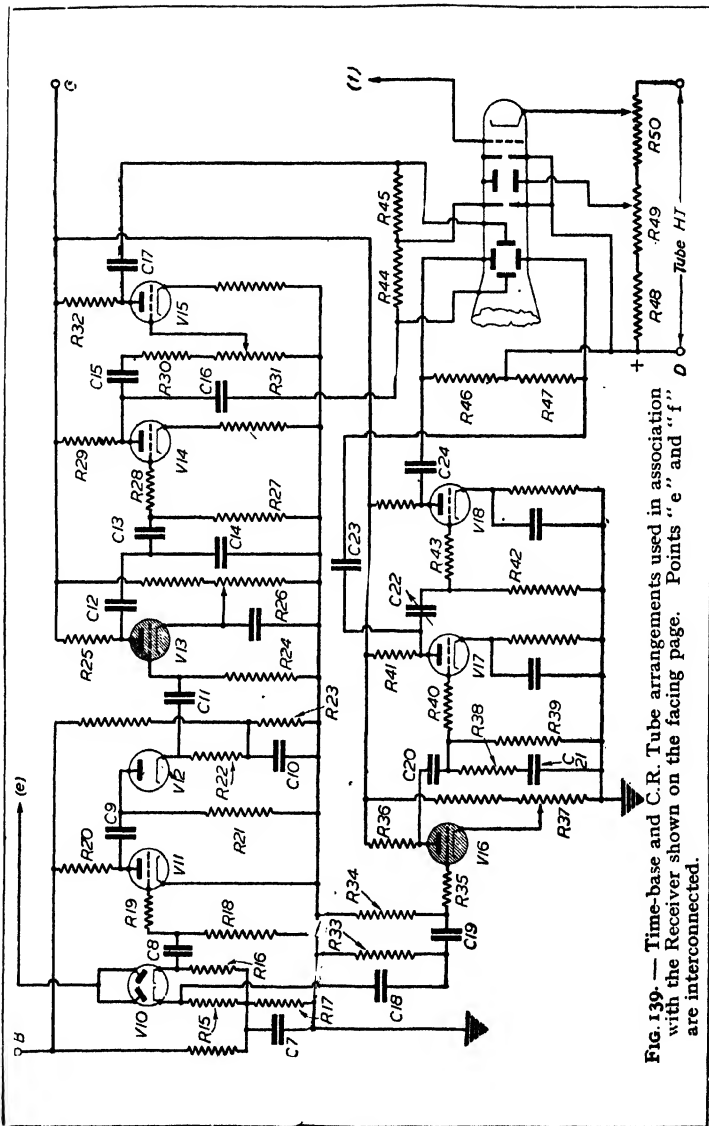

Fig. 139. — Time-base and C.R. Tube arrangements used in association with the Receiver shown on the facing page. Points "e" and "f" are interconnected.

CALIBRATING A RECEIVER

Those who are able to receive foreign stations are often mystified by receiving a station, and, being unable to understand the announcements, cannot get any idea whether it is a low-powered station at a great distance, or a high-powered station near by. It is convenient to be able to make a note of the various countries heard on a set, and at the same time being able to know where to set your tuning dials to pick up any station when you see from the newspapers or some other periodical that a certain item is being broadcast which you would like to hear. It is not very difficult to draw up a chart which will make it possible to do all this, and it need only cost a few pence.

Marking out the Paper.—You will need a sheet of squared paper, generally known as graph paper. This is usually obtainable from most good stationers or artists' supply stores. It does not matter whether the squares are in tenths of an inch or millimetres, the actual size chosen depending on the room you wish the chart to occupy when it is finished. Rule along one of the lines near the bottom of the sheet, and mark along this the numbers corresponding to those on your tuning dial. This may be 0 to 100 or 0 to 180, it does not make any difference which it is. Now at the left-hand side of the sheet rule a vertical line running from the line marked with the 0. Along this line you must mark the metres (or frequencies in kilocycles, just as you desire) corresponding to the tuning range covered by your condenser. If the tuning condenser is of the type known as a "log" scale, then it is preferable to mark the tuning range in kilocycles. For the other types of condenser use the metre scale. Of course, you may, if you wish, mark this in both the frequency and the wavelength. Having done this, you may settle down to the more interesting job of calibrating your set. First of all tune in to your local station. If possible, avoid the use of reaction when carrying out this calibration. Having tuned-in to the exact spot, make a careful note of the reading on the dial. Now find this spot on the bottom line of your chart, and run your pencil up the vertical line above this spot until you arrive at the place where the horizontal line corresponding to the wavelength of the station crosses it. Make a small dot at this spot. Now tune in another loud station, and carry out the same process. When you have, say, three or four dots on your chart, carefully join them up with a light pencil line. Now find the wavelength of a station which you

have not yet marked, but which you can receive, and run along this line until you arrive at your pencil line. Drop down the vertical line and see the dial reading this gives. If now you set your dial to this spot you should hear the station, but if any slight retuning is necessary, carry this out, and make the necessary alteration to your pencil line.

Identifying a Station.—To use the chart in identifying a station which you may receive, note the dial reading, and, as explained above, find its wavelength.

If your set consists of a detector valve followed by L.F. stages, you will have to use reaction during the compilation of the chart, and to avoid variations due to the varying amounts of applied reaction, use this at its maximum. For receivers using H.F. stages, it is preferable to calibrate the condenser which tunes either the H.F. transformer, tuned anode, or detector circuit.

Practical Wireless BLUEPRINT SERVICE

These blueprints are drawn full size. The issues containing descriptions of these sets are now out of print, but an asterisk beside the blueprint number denotes that constructional details are available, see with the blueprint.

The index letters which precede the Blueprint Number indicate the periodical in which the description appears: thus P.W. refers to *Practical Wireless*, A.W. to *Amateur Wireless*, W.M. to *Wireless Magazine*.

Send a postal order to cover the cost of the Blueprint to PRACTICAL WIRELESS Blueprint Dept., George Newnes Ltd., Tower House, Southampton Street, Strand, W.C.2.

PRACTICAL WIRELESS

	No. of Blueprint		No. of Blueprint
CRYSTAL SETS		Three-valve: 2s. each.	
1s. 6d. each.		Experimenter's Short-wave Three (SG, D, Pow)	PW30A*
1937 Crystal Receiver	PW71*	The Perfect 3 (D, 2 LF (RC and Trans))	PW63*
The "Junior" Crystal Set	PW94*	The Band-spread S.W. Three (HF Pen, D (Pen), Pen)	PW68*
2s. each.		PORTABLES	
Dual-Wave "Crystal Diode"	PW95*	1s. 6d.	
STRAIGHT SETS		The "Mini-Four" All-dry (4-valve superhet)	
Battery Operated		MISCELLANEOUS	
One-valve: 2s. each.		2s. each.	
The "Pyramid" One-valver (HF Pen)	PW93*	S.W. Converter-Adapter (1 valve) ..	PW48A*
The Modern One-valver	PW98*	(2 sheets), 7s. 6d.	
Two-valve: 2s. each.		The P.W. 3-speed Autogram	
The Signet Two (D & LF)	PW76*	The P.W. Electronic Organ (2 sheets), 7s. 6d.	
3s. each.		TELEVISION	
Modern Two-valver (two-band re- ceiver)	PW98*	The Practical Television Receiver (3 sheets), 10s. 6d.	
Three-valve: 3s. 6d. each.		The "Argus" (6 in. C.R. Tube), 2s. 6d.	
Summit Three (HF Pen, D, Pen) ..	PW37*	AMATEUR WIRELESS AND WIRELESS MAGAZINE	
The "Rapide" Straight 3 (D, 2 LF RC & Trans))	PW82*	STRAIGHT SETS	
F. J. Camm's "Sprite" Three (HF, Pen, D, Tet)	PW87*	Battery Operated	
3s. each.		One-valve: 2s.	
The All-dry Three	PW97*	B.B.C. Special One-valver	AW387*
Four-valve: 2s. each.		Two-valve: 2s. each.	
Fury Four Super (SG, SG, D, Pen) ..	PW34C*	A modern Two-valver	WM409*
Mains Operated		Mains Operated	
Two-valve: 2s. each.		Two-valve: 2s. each.	
Selectone A.C. Radiogram Two (D, Pow)	PW19*	Conslectric Two (D, Pen), A.C. ..	AW403
Three-valve: 3s. 6d. each.		SHORT-WAVE SETS	
A.C. Band-Pass 3	PW99*	Battery Operated	
Four-valve: 2s. each		One-valve: 2s. each.	
A.C. Fury Four (SG, SG, D, Pen) ..	PW20*	S.W. One-valver for America	AW429*
A.C. Half-Mark (HF Pen, D, Push Pull)	PW45*	Two-valve: 2s. each.	
SUPERHETS		Ultra-short Battery Two (SG, det Pen)	WM402*
Battery Sets: 2s. each.		Four-valve: 3s. each.	
F. J. Camm's 2-valve Superhet	PW52*	A.W. Short Wave World-beater (HF Pen, D, RC, Trans)	AW436*
Mains Operated: 3s. 6d. each.		Standard Four-valver Short-waver (SG, D, LF, P)	WM883*
"Coronet" A.C.4	PW100*	Mains Operated	
SHORT-WAVE SETS		Four-valve: 3s.	
Battery Operated		Standard Four-valve A.C. Short- waver (SG, D RC, Trans)	WM391*
One-valve: 2s. each.		MISCELLANEOUS	
Simple S.W. One-valver	PW88*	Enthusiast's Power Amplifier (10 Watts) (8s.)	WM887*
Two-valve: 2s. each.		Listener's 45-watt A.C. Amplifier (8s.)	WM892*
Midget Short-wave Two (D, Pen) ..	PW38A*	De Luxe Concert A.C. Electrogram (2s.)	WM403*

**CONSISTENTLY
SPECIFIED**

by

**LEADING
DESIGNERS**

Stentorian

**PERMANENT MAGNET
LOUDSPEAKERS**

From $\frac{1}{2}$ " to 18"



**"C" TYPE CORES
TRANSFORMERS
VALVEHOLDERS
AMPLIFIERS
ETC.**

● Full details on request

WHITELEY ELECTRIC RADIO CO. LTD. MANSFIELD. NOTTS

RELIABLE NEW CIRCUITS Every Month . . .

Month by month **PRACTICAL WIRELESS** brings the modern enthusiast new circuits which include all the latest improvements in design. Edited by F. J. Camm, this famous technical journal is packed with essential information for expert and amateur alike on all phases of modern radio. Regular features include authoritative articles by leading radio experts; sponsored designs of guaranteed receivers; special short-wave features; news and views from the radio world; comprehensive Blueprint Service; Free Advice Bureau.

***PRACTICAL WIRELESS** will keep you right up-to-date with the latest developments in every branch of radio. Order it from your Newsagent today.*

PRACTICAL WIRELESS

MONTHLY

**Every practical radio man
needs this standard work
of reference . . .**

EVERYMAN'S WIRELESS BOOK

by F. J. Camm

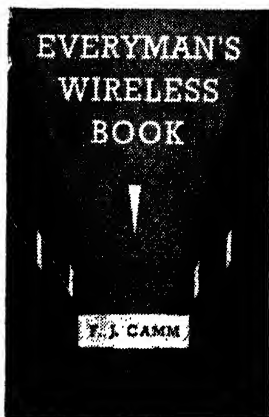

This important volume forms an elementary introduction to the principles of radio transmission and reception. It takes the reader from first principles through the various steps from the microphone to the reception of the programme in the home. It dispenses with mathematical formulae, and guides the reader through easy stages to such subjects as fault finding, the building of receivers, and the obtaining of perfect reception. It has been written by an acknowledged authority on radio design, and it has been prepared with the needs of every listener in mind, the amateur, the experimenter, and the ordinary listener.

Only
296 pages • 224 illustrations • 12s. 6d. net

**Now in its 11th Edition! A certain
sign of its accepted authority**

NEWNES

FROM ALL BOOKSELLERS . . . or
13s. post free from
George Newnes Ltd., Southampton
Street, London, W.C.2

B O O K S
are
T O O L S

NEWNES are renowned throughout the publishing world for their technical books, which are planned for the practical man. The Newnes list is almost sure to contain the very volume you want to assist you in your job. Ask your bookseller to keep you informed, or, in case of difficulty, write, stating your particular interest, to: Book Dept., George Newnes, Ltd., Tower House, Southampton Street, Strand, London, W.C.2.

Subjects covered include Radio, Television, Radar, Engineering, Mechanics, Chemistry, Plastics, Electrical Engineering, Telecommunications, Building and Civil Engineering, et etc.

NEWNES

CENTRAL LIBRARY
BIRLA INSTITUTE OF TECHNOLOGY & SCIENCE
PILANI (Rajasthan)

Call No.

Acc. No.

51385

DATE OF RETURN

--	--	--	--

