

Birla Central Library

PILANI (Jaipur State)

Class No :- 136.7

Book No :- W 115

Accession No :- 10604

**RIVERSIDE TEXTBOOKS
IN EDUCATION**

EDITED BY ELLWOOD P. CUBBERLEY

**DEAN EMERITUS, SCHOOL OF EDUCATION
LELAND STANFORD JUNIOR UNIVERSITY**

AN INTRODUCTION TO CHILD PSYCHOLOGY

BY

CHARLES W. WADDELL, Ph.D.

PROFESSOR OF EDUCATION AND DIRECTOR OF TRAINING SCHOOLS
UNIVERSITY OF CALIFORNIA AT LOS ANGELES

GEORGE G. HARRAP AND COMPANY, LTD.
LONDON BOMBAY SYDNEY

The Riverside Press
CAMBRIDGE · MASSACHUSETTS
PRINTED IN THE U.S.A.

EDITOR'S INTRODUCTION

THE child-study movement of two decades ago rendered perhaps its most important service in turning the attention of students of education to the study of children, rather than of theories about children. Many studies were made and much child-study literature was accumulated. Some of these studies were carefully made and are still of value, though much of what was then done is not now regarded as of fundamental importance. In place of this older child-study movement there has since arisen a newer child or genetic psychology, developed along better scientific lines and better directed. It has based its work not only on the study of children themselves, but also on biology, heredity, experimental pedagogy, and the newer studies of behavior as well. This more recent work has made the earlier textbooks, written from the point of view of the old child study and a limited psychology, out of date. It is an introduction to this newer point of view which has been attempted in the present volume.

No attempt has been made by the author to write a complete treatise on child psychology, as the subject is still developing so rapidly that the time for this is not yet ripe. He has, however, presented a treatise covering the more important aspects of the new subject, and has selected for presentation those phases which are most fundamental to teacher and parent. The best that the child-study movement contributed has been organized and presented, the status of our present knowledge as to child psychology has been set forth, and then, by citations to a series of carefully selected bibliographies, he has put the reader in touch with

the best literature on each phase of the subject here presented. Because of these, and the method of presentation followed, the book has large teaching value, and also will be valuable to the reader interested in an intelligible key to the mass of literature relating to the intellectual development of children which the last quarter of a century has seen accumulated.

The point of view is the modern biological. The first chapter is a historical statement as to the scientific study of children, and serves to set off the present-day work in proper perspective. The second chapter describes the methods of studying children. The third gives a good simple treatment of child life, from the biological point of view, and puts the subject in proper biological perspective. This is followed by a chapter dealing with human behavior and the instincts, in which the use of the term "instincts" is carefully restricted within scientific limits, and the usual loose thinking on the matter of instincts avoided. Play, language, and drawing are then selected for treatment as representing three typical child activities with instinctive bases, and as illustrating the mental development of the child. The knowledge we have as to genetic development along these three lines, and the teaching of these three subjects, follows. The author then takes up the questions of heredity and environment as showing themselves in the moral nature of children and in juvenile delinquency, — heredity, environment, and the moral nature of children being the central subjects toward which the whole book has been leading. The general facts and principles of mental development, and some of the established laws for this, followed by a consideration of individual mental capacities, closes the treatment.

The present volume is the outgrowth of a number of years of experience in teaching the fundamentals of child psychol-

ogy, on the part of the author, to students in two of our larger State normal schools, and the organization, treatment, questions, and bibliographies which this volume contains are all the resultant of classroom experience. The treatment is intended to open up to the student and reader this new field, to select from the wealth of literature relating to child development that which is best and most pertinent, and, where our present knowledge warrants so doing, to make definite pedagogical applications. It lays a thorough foundation for the intelligent reading of books on education, or for courses on educational theory and educational psychology. Presenting as it does the best organization and treatment so far effected on a number of the more important phases of this rapidly developing field, this volume should prove very useful to teachers of child psychology, applied psychology, or genetic psychology in normal schools and colleges, and of deep interest to thoughtful teachers and parents.

ELLWOOD P. CUBBERLEY.

PREFACE

THIS book is intended primarily to serve as an introduction to the study of child psychology in normal school, college, and university classes, but the topics have been so chosen and so treated that parents, teachers, and social workers should find it useful. The essential content of every chapter has been the direct outgrowth of the author's effort to cull from the vast literature of child psychology, and to organize for use in his own classes, such knowledge as is of first importance.

Satisfactory treatment of the entire field is no longer possible in a single volume. The author has, therefore, chosen the plan of a somewhat intensive treatment of a few closely related and vitally important topics which, experience has proved, give proper perspective and leave lasting interest.

The scope of the book makes it necessary to presuppose some knowledge of general psychology and of child hygiene and some familiarity with the principles and point of view of modern biology. Those who have such a foundation are at a distinct advantage, but the lack of it should not prove an insuperable difficulty.

Upon the topics treated there is little room for finality and none for dogmatism. Our aim is to stimulate the reader to think about, to study, and to observe real children intelligently, sympathetically, and scientifically. If we can to any degree inspire caution, scientific reserve, open-mindedness, and a passion for facts; if we can open the eyes of the student to more careful observation; if we can to some extent prevent hasty and unwarranted inferences and

consequent misjudgment and mistaken treatment of children, — we shall have rendered a much-needed service.

In a field in which such a variety of opinion still prevails, we cannot hope to please all readers either with our choice of topics or our method of treatment. We have made an honest and earnest endeavor to present, as impartially and as accurately as possible, the best-established facts and principles of the new and growing science of childhood in the fields we have treated.

The scope of the book makes impossible that richness of illustration which the author uses in his own teaching. Amplification and illustration by the teacher and further reading by the student should make clear and add interest to the points of the text and suggest their application to education and child training. Many of our chapters are intended only to open the topics to further reading and study. For this reason we have appended to each chapter a bibliography carefully selected from the best of the older and the best of the new literature of the subject. These bibliographies suggest the sources to which we are indebted and the materials which students should use for further reading. The purposes to be served by them have restricted us almost wholly to references in English, to those of real and relatively lasting value, and to such as are likely to be available in the libraries of normal schools and colleges.

The obligations of the author are greatest to those whose names appear oftenest in the bibliographies and on the pages of the text, where acknowledgment of indebtedness is made. Grateful acknowledgment is made to the hundreds of young people who by their response, in his classes, to what is here presented have rendered the author a very great service. He is under special obligation to his associate Mr. William T. Root, whose assistance, first in the formulation of the outline of the work and later in criticism of the

PREFACE

xi

manuscript, has been invaluable. Valuable criticisms of chapters XI and XII, by his associate Dr. S. Carolyn Fisher, are gratefully acknowledged. Special thanks are due, also, to his former pupil, Miss Grace Brainard, for the preparation of a number of the drawings that appear in the book and to the authors and publishers who have kindly consented to allow the reproduction of cuts and charts from their publications.

CHARLES W. WADDELL.

LOS ANGELES, CAL.
March, 1918.

CONTENTS

CHAPTER I. HISTORICAL BACKGROUND OF THE SCIENTIFIC STUDY OF CHILDREN 1

A new estimate of the value of child life — Indifference of former ages — Modern change of attitude — The history of the child — Infanticide — Cannibalism — Human sacrifice — Mutilation and abuse — Chattel slavery — Industrial slavery — The school and the child — The history of scientific study of children — Recorded observations — Societies — Proceedings — The movement abroad — Child welfare — Recent movements — Research laboratories.

Questions and topics — Bibliography.

CHAPTER II. METHODS OF SCIENTIFIC STUDY OF CHILDREN 30

The value and importance of scientific method — The methods most frequently used — Biographical — Direct question — Clinical — Questionnaire — Statistical — Statistical terms — Parallel groups — Intelligence tests — Interpretation of results.

Questions and topics — Bibliography.

CHAPTER III. BIOLOGICAL PERSPECTIVE 51

Application of the evolutionary principle to the study of child life — The theory of descent — Evidences — Darwin's contribution — The cell theory — Genetics — Fertilization — Mitosis — Rise of parts and organs — The physical recapitulation theory — Prenatal influences.

Questions and topics.

CHAPTER IV. HEREDITY 71

Racial and individual heritage — Definition — Inevitableness — Theories of variation and heredity — Continuity of germ plasm — Germinal selection — Mendelism — Mutation — Galton's laws — Inheritance of acquired characters — Heredity and environment — Scientific studies of heredity — Social heredity.

Questions and topics — Bibliography.

CHAPTER V. NON-LEARNED HUMAN BEHAVIOR . . . 94

Problems of human behavior — Chemo-physical basis of behavior — Structural basis of behavior — Classes of human behavior — Nature of instinct — The stimuli which arouse instincts — Characteristics of human instincts — Complexity of human activities — Emotion and instinct — Classification of instincts — General pedagogical bearing of non-learned behavior — Typical instincts important in education.

Questions and topics — Bibliography.

CHAPTER VI. THE PLAY OF CHILDREN . . . 123

Play and work — Theories of play — The superfluous energy theory of Schiller-Spencer — The preparatory theory of Groos — The recapitulatory theory of Hall — The relaxation theory of Patrick — What children play — The age factor — The sex factor — Racial factors — The values of play.

Questions and topics — Bibliography.

CHAPTER VII. THE LINGUISTIC DEVELOPMENT OF CHILDREN . . . 153

Definition of language — Theories of the origin of speech — Ontogenesis of speech — Heredity and speech — Linguistic stages — First steps in learning — Secret languages — Slang — Vocabularies — Methods of study — Use of parts of speech — Definitions by children — Use of the sentence — Linguistic activity of a single day — Speech and intelligence — Word tests — Considerations in judging intelligence — Summary.

Questions and topics — Bibliography.

CHAPTER VIII. CHILDREN'S DRAWINGS . . . 185

Instinctive basis of artistic expression — Racial origins — Studies of children's drawings — Genetic stages in drawing capacity — What children draw — Characteristics of children's drawings — Individual and sex differences — Correlations — Values of drawing — Summary.

Questions and topics — Bibliography.

CHAPTER IX. THE MORAL NATURE OF CHILDREN . . . 209

The point of view of child morality — Social nature of morality — Stages of moral development — Instinctive basis of mo-

CONTENTS

xv

ality and immorality — Ownership — Curiosity — Truancy — Lies — Obstinacy — Teasing and Bullying — Imitation — Summary.

Questions and topics.

CHAPTER X. JUVENILE DELINQUENCY 226

Definition — Causes — Heredity — Instinct and crime — Feeble-mindedness and crime — Significance of feeble-mindedness — Other hereditary causes — Environmental causes — The gang — Physical defects and delinquency — The age of the delinquent — The nature of juvenile delinquency — The typical delinquent — Remedies for delinquency — Summary.

Questions and topics — Bibliography.

CHAPTER XI. GENERAL MENTAL DEVELOPMENT 255

I. GENERAL FACTS AND PRINCIPLES

The problems — The nature of mind — The origin of mind — When does consciousness begin? — The nature of consciousness in the newborn — Periods of development — Laws of development — Some general principles — Summary.

Questions and topics.

CHAPTER XII. GENERAL MENTAL DEVELOPMENT 279

II. PARTICULAR CAPACITIES

Sense-perception and apperception — Attention — Association — Memory — Imagination — Evolution of the feelings and emotions — Reasoning — Conclusion — Summary.

Questions and topics — Bibliography.

SUGGESTIONS 303

GLOSSARY 305

INDEX OF SUBJECTS 309

INDEX OF NAMES 315

FIGURES IN THE TEXT

1. Ovum and spermatozoön	59
2. The parent cell	61
3. Cell division	62
4. Heredity, environment, and training	72
5. Illustrating the continuity of germ plasm	74
6. Illustrating Mendel's law	77
7. Interest in various games	135
8. Running and chance games	142
9. Rivalry and coöperation in play	143
10. The pictorial evolution of man	199
11. Relation of age and crime	243
12. Prevalence of good conduct at different ages	244

TABLES

I. Average vocabularies at different ages	166
II. Parts of speech in child vocabularies	167
III. Estimates of parts of speech in the dictionary	168
IV. Parts of speech as actually used	169
V. Linguistic activity for a single day	174
VI. Age of beginning to talk	175
VII. Vocabulary test — imbeciles	176
VIII. Intelligence tests of juvenile delinquents	234

AN INTRODUCTION TO CHILD PSYCHOLOGY

CHAPTER I

HISTORICAL BACKGROUND OF THE SCIENTIFIC STUDY OF CHILDREN

A new estimate of the value of child life. Any sketch of the brief history of the movement for the scientific study of children is incomplete and inadequate that is not drawn upon a background of preceding social, industrial, and educational history. We cannot know whether the scientific study of child life has furthered humanitarian, scientific, and educational ends until we know the attitude and practices of previous epochs in regard to children. If the movement has accomplished anything, or if it holds any promise for the future, this can be made clear only when we know something of the facts in the case. It is not our purpose here to write either a culture history of the child or a complete sketch of scientific child study, but we do wish, in this introductory chapter, to point out the necessity of both lines of study for those who desire to have a true conception of the significance of the movement to which it is the purpose of this book to introduce the student. Holding, as we do, that the evolutionary and genetic point of attack is as essential in this field as it is in botany, zoölogy, physiology, or biology, as well as in such sciences as anthropology, sociology, and history, the few facts we have space to present are brought forward to give something of a perspective in the new and rapidly growing science of the child.

CHILD PSYCHOLOGY

The task of discovering the exact status of childhood in earlier ages and under different forms of civilization is by no means an easy one, and has as yet been undertaken in only a partial and a fragmentary way. The history of child life has been strangely neglected by all the historians of human life. One might almost infer that there were no children or that children had no recognized place in human society until recently, for all that most of the history and literature of the past centuries tell us of them. This fact itself is most significant, especially when we contrast with it the situation to-day. In the last fifty years the literature about children has multiplied tremendously and at an increasing rate, until to-day no one person can hope to be familiar with more than some few phases of it. It is perhaps not too much to say that more has been written about children and more study made of them in the past fifty years than in all the history of the world before that time. A pamphlet of twenty-five pages or so is now required merely to list the writings of a single year. Such a sudden and unprecedented rise of interest and change of attitude deserve some explanation. It is our hope that this chapter and others in this book will shed some light on the situation. One thing is certain. The eyes of the world are turned upon childhood as never before in all history.

Among the few attempts that have been made to gather together such knowledge as can be had from scattered sources, as to the attitude toward children in previous ages, the most notable ones available to English readers are those of Chamberlain (5), Kidd (20), and Payne (25),¹ to whom the reader must be referred for much that can here only be hinted at. The contributions of Dr. Ploss, in *Das Kleine Kind*, etc., are as yet unavailable in English. The signifi-

¹ These numbers here, and throughout the book, refer to the numbered bibliographies found at the close of each chapter.

cance of these anthropological studies lies chiefly in the fact that in a very true sense the history of the attitude of humanity toward its own offspring is the history of the rise of altruism, humanitarianism, morality, justice, order, and of civilization itself in its best sense. The rapidity with which civilization and humanitarianism advance in the future will without doubt be very definitely conditioned by the degree to which we recognize the necessity, profiting by the mistakes of the past, of assuming thoughtful, reverent, and right attitudes toward the greatest asset of any civilization — its children.

More than two thousand years ago the great Hebrew prophet Isaiah declared that in a day when the golden age of prophecy shall arrive "a little child shall lead them." Nearly two thousand years ago the Great Teacher proclaimed to his disciples, after having "called to him a little child and set him in the midst of them," that "of such is the kingdom of heaven." In spite of the voice of these and other seers and prophets the united voice of many such in our own day finds difficulty in convincing men generally that the "greatest in the kingdom of anthropology is assuredly that little child" (5, p. 2). Few people as yet appear to be convinced, with Hall, that "childhood is the paradise of the race from which adult life is a fall"; or that, as Brinton says (5, p. 2), "the child, the infant in fact, alone possesses in their fullness, 'the chief distinctive characters of humanity. The highest human types, as represented in men of genius, present a striking approximation to the child-type. In man, from about the third year onward, further growth is to some extent growth in degeneration and senility.' Hence the true tendency of the progressive evolution of the race is to become child-like, to become feminine."

This widely accepted view of anthropologists that the

child and the woman are better, more adequate representatives of all that is best in the race, which Havelock Ellis has elaborated in his *Man and Woman*, and which has permeated the writings of G. Stanley Hall, should direct our attention toward childhood. May it not be that woman stands more surely for the best things in life because, far more than man, she follows the lead of the child, understands childhood better, sympathizes more with it, and appreciates it more truly. If this be true we must agree with Chamberlain (5, p. 5) that "The consideration of 'The Child in Folk-Thought,' — what tribe upon tribe, age after age, has thought about, ascribed to, dreamt of, learned from, taught to, the child, the parent-lore of the human race, in its development through savagery and barbarism to civilization and culture, — can bring to the harvest of pedagogy many a golden sheaf." This kind of "child study" cannot and does not pretend to work by the same methods or attain to the same kind of results as the scientific study of the laboratory. "Its laboratory of research has been the whole wide world, the experimenters and recorders the primitive peoples of all races and all centuries, — fathers and mothers whom the wonderland of parenthood encompassed and entranced; the subjects, the children of all the generations of mankind" (5, p. 5). Such study is, however, no less important and valuable in its place than the most careful scientific investigations which the most expert scientist can make. Indeed it is just the kind of study the scientist needs to humanize his efforts and to keep his sympathies alive.

It is no small service that has been rendered us, then, by those who, like Chamberlain, have attempted "to exhibit what the world owes to childhood and the motherhood and the fatherhood which it occasions, to indicate the position of the child in the march of civilization among the

various races of men, and to estimate the influence which the child idea and its accompaniments have had upon sociology, mythology, religion, language" (5, p. 6). The magnitude of our indebtedness to childhood in all these respects is most inadequately appreciated. The further one goes into the study of this debt the more one must be impressed with the fact that, of all the studies which the student may undertake, the study of childhood is the most universally useful and significant.

All who have any adequate knowledge of the history of civilization in other respects will be prepared for the discovery that the development of a high regard for childhood has been exceedingly slow. Even the very emotions—tenderness, sympathy, humanity—first aroused by the helplessness of infancy, have often signally failed to protect the lives of infants and to safeguard childhood from misery, abuse, and the grossest exploitation. "The march of civilization" is not necessarily synonymous with social progress. Humanitarianism has not always advanced hand in hand with the progress of philosophy or religion. The history of human life is full of paradoxes. The snail's pace at which the race has moved toward humanitarianism is indicated by Payne's estimate (25, p. 6) that the race is perhaps two hundred and forty thousand years old, civilized man a few hundred years, and a humanitarianism large enough to have any real concern in any organized fashion for the protection of children scarcely fifty years old. The fact that organizations in great number, laws, penalties, and constant vigilance are still everywhere needed to secure for children their inherent rights is evidence enough that we have still a long way to go before we reach the golden age. Humanitarians there have been in almost every age, but the humanitarianism of Jesus, the Jewish prophets, Confucius, Plato, Aristotle, Gautama, and many lesser lights

since their day is only now beginning to influence our attitude of indifference and inhumanity to children after the lapse of centuries.

The child in history. The following facts, selected from Payne (25), who has taken great care to examine and bring together a vast amount of anthropological literature, are introduced in the hope that the revolting picture they present may serve to help those who read them to appreciate the position of childhood in earlier ages, and perhaps to enlist them more unreservedly in the cause of neglected and abused childhood in our own day.

Infanticide has been more or less prevalent in every age and under all stages of civilization. So far as can be learned the underlying causes have usually been social and economic, though others often appear on the surface. In many tribes the definite limitation of offspring reared to maturity is enforced by laws. The Papuans of British New Guinea are said not to desire children. Regarding them as a nuisance and seeing for them no certain future, they find many ways of getting rid of most of their children. Among others the custom of burying children alive when parents or persons of importance die, that the child may wait on his elders in the other world, is widespread (p. 26). A Central Australian tribe immediately kills twins "as something which is unnatural"; a Northern tribe "as something uncanny" (p. 32). Among Western Victorian tribes, because of the scarcity of food and the nomadic habits of the tribe, "it is lawful and customary to destroy the weaker twin child, irrespective of sex." In parts of the continent the mother of twins is often sacrificed with them. Australian aborigines, like the ancient Spartans, customarily destroy all malformed infants (p. 34).

Curious superstitions grow to be customs justifying infant destruction. From various tribes the following are

typical: all infants are to be destroyed whose birth causes the death of the mother; those born with teeth already cut; those born in stormy weather or on unlucky days; those who sneeze at or shortly after birth; those born in any way considered unusual; those who cry at or soon after birth and the like (p. 35). In the great majority of cases it has been the female infant that has suffered oftenest. "In South America it was the custom for the women to bury alive the majority of their female children, and they never brought up more than one boy and one girl" (p. 36). Female children in India have for ages been doomed to a most unwelcome reception. Over them the father had power of life and death. The sad fate of the child-widows of India is well known. During the nineteenth century the British Government received many protests against its efforts to stop the practice of killing daughters, which had been in vogue for forty-nine hundred years. Conditions were not dissimilar in ancient China, and a recent investigation in forty villages of a certain province indicates that a short time ago an average of forty per cent of all the girl babies were exposed or otherwise destroyed (p. 67). The Homeric Greeks left it entirely to the father to decide whether a child was worth rearing. He had the power to destroy it if he so desired. In Athens infanticide was an accepted practice (p. 191). They might rear the first child; a second was usually condemned to die (p. 195). The Athenian rule is said to have been "The son is brought up even if one is poor; the daughter is exposed, even if one is rich" (p. 198). During the sixteenth and seventeenth centuries infanticide was very common in France.

Cannibalism is closely associated with infanticide in many cases, in fact it is one of the causes in times of economic stress or famine. It is common among such primitive peoples as the Papuans. In one village a British Governor

found no girls, since all had been killed and eaten in a recent raid (pp. 26, 27). In parts of New South Wales "The first born of every *lubra* was eaten by the tribe as a part of the religious ceremony" (p. 147). "Bathing in blood, especially the blood of children, in Northern India was regarded as a powerful remedy for disease" (p. 148). In times of famine cannibalism often breaks out when not prevalent at other times. Such an outbreak occurred in Japan not over one hundred years ago. At such times children, especially female children, were the first to suffer.

Human sacrifice seems to have been only a little less widespread. At the coronation of their princes the Peruvians sacrificed two hundred children (p. 146). In India human sacrifices were common in some sections till 1800. The sacrifice of children to the sacred Ganges continued up to the beginning of the present century. The ancient Aryans "practiced human sacrifice and they retained after birth only those children that they could conveniently rear, or those male children who were regarded as necessary for the increase of the fighting forces of the tribe" (p. 122). In Japan the god of wild animals was statedly placated by the sacrifice of a girl. Human sacrifice unquestionably prevailed among the early Hebrews, as it did among their neighbors. In the later substitution of animals they did not stand alone. Abraham's call to sacrifice his only son called forth sorrow, but evidently no surprise. Jephthah sacrificed his daughter to fulfill a vow. Kings Ahaz and Manasseh (sixth and seventh centuries B.C.) sacrificed sons and established the worship of Moloch, the chief feature of which was the sacrifice of children. The great prophets had constant difficulty to prevent the recurrence of such practices. Further occasions for human sacrifice can only be enumerated. Among them are sacrifices to secure good crops, successful business journeys, to render a city impregnable,

to keep evil spirits away, to prevent the plague, and the like. In the custom remaining till to-day of breaking a bottle of champagne over the bow of the newly launched vessel there survives the custom which once called for the death of a human victim to insure successful launching. Our own foundation ceremonies and corner-stone layings remind those who know the anthropological history of India, New Zealand, China, Japan, Mexico, Germany, Denmark, and perhaps other countries, of the custom of walling in a living child to make the building more secure for those who were to use it. Payne thinks that the establishment of rituals demanding sacrifice of children to propitiate the gods, and incidentally to reduce economic burdens, may have been a device of man to appease the opposition of woman by a religious appeal. Certain it is that the maternal instinct often rebelled against the cruel destructiveness of man.

Mutilation and abuse of children has been all too common in every age. The Roman father had the power to sell, mutilate, or kill his children, even after they reached maturity. There seems little doubt that many children exposed, according to the custom of the day in Greece and Rome, were as foundlings horribly mutilated so that their condition might be a means of securing alms for their masters as beggars in the streets. This practice was common in France in the sixteenth and seventeenth centuries, and was an important cause of the arousal of public-spirited citizens to undertake child-protective work. Unfortunately the mountebank is still with us when he dares to be.

Lawful punishments of children were excessively severe. The code of Hammurabi (2250 B.C.) prescribes very severe punishment for disrespect or repudiation of a parent, but the parent, especially the father, had almost free rein with the child. The Mosaic law was not less severe. "He that

curseth his father, or his mother, shall surely be put to death," to quote a single example. In old feudal days in Japan, prior to the eighteenth century, "children were punished for the crime of their parents" even to the extent of death for male and slavery for female children.

Slavery of children is an ancient institution. The Roman father long had the right to sell his child into slavery. The Mosaic law made provisions concerning the same right. In the European States that succeeded the Western Roman Empire, abandoned children became the slaves of those who reared them (p. 289). Among the Gauls there was a time when children were sold into slavery by their families. This was true also in the British Islands. Many Greek and Roman foundlings were saved from death only to become slaves if not redeemed, as they sometimes were, by their parents. As late as 1905, during the famine in Japan, many girls were sold by their parents (p. 87). But we need not go so far from home. The investigations of the Vice Commission in Illinois have proved that to-day in our own country thousands of young girls are bought and sold in our great cities to a worse slavery than the negro ever suffered.

But chattel slavery at its best is better than industrial slavery at its worst. Every country and every age has its social sins to answer for. For industrial abuses the England of the seventeenth and eighteenth centuries will have most to answer for in this regard. Conditions in industry, beginning as early as the eleventh century, made children useful. For protection from infanticide they paid by the worse calamity of slavery in mills and factories. Invention of machinery, and the consequent demand for cheap labor, caused laws to be enacted which made the overseers of the poor in effect the slave agents for the mill-owners. "Nominally," says Payne, "the children were appren-

tices, but actually they were slaves and their treatment was most inhuman" (p. 319). As late as 1840 children of ten to fifteen years and younger were driven by merciless overseers for ten, twelve, sixteen, even twenty hours a day in the lace-mills. Fed the coarsest of food, in ways more disgusting than those in the boarding-schools described by Dickens, they slept, when they had opportunity, often in relays, in beds that were constantly occupied. They lived and toiled day and night in the din and noise, the filth and stench, of the factory that coined their life's blood into gold for their exploiters. Sometimes with chains about their ankles, to prevent their attempts to escape, they labored till epidemics, disease, or premature death brought welcome relief from a slavery that was forbidden by law for negro slaves in the colonies. It was even testified, in a hearing in 1815, that a whole gang of such children were sold with the other effects of a bankrupt (p. 324). This and much more could be said, but we would not have harassed the feelings of the reader with this revolting recital even thus far were it not for the fact that the battle for the emancipation of helpless childhood is not yet wholly won.

Something of what remains to be done in the interest of child welfare may be judged from the following quotation from Bonger (3, pp. 319, 320), who quotes it from a German writer:—

If the reader will imagine a procession of 109,000 children marching past him, and will notice attentively child after child as it goes by, he will get some idea of the extent of the suffering of children with which the *National Society for the Prevention of Cruelty to Children in England* has actually had to do during the first ten years (1884-94) of its existence.

The first 25,437 are sufferers from injuries inflicted upon them with boots, crockery, pans, shovels, straps, ropes, pokers, fire, boiling water, in short with every imaginable instrument that came to the hand of the brutal and vindictive parents — covered

with wounds and bruises, burned, scalded, and covered with plasters and bandages.

Then come 62,887 sufferers from neglect and starvation — covered with dirt, eruptions, and sores, trembling, in rags, half-naked, pale, weak, faint, feeble, pining, starving, dying — many of them borne in the arms of the nurses of the hospitals.

Then come 713 funeral processions, where the maltreatment ended fatally.

Then come 12,663 little beings, their sufferings displayed to turn the lazy and cruel benevolence of the street to those who are answerable for their pallor, leanness, and coughs — most of these, too, are still in arms, but in the arms of vile drunkards and vagabonds.

Then come 4460 pitiable girls, victims of the lust of human monsters.

Then come 3205 little slaves of unsuitable and harmful occupations and dangerous performances, untimely births in traveling vans, acrobats at fairs, trapeze performers and tight-rope walkers in circuses, laboring under too heavy a load, and suffering the most diverse outrages. The procession is sixty miles long and takes twenty-four hours to pass by.

Bonger calls attention to the fact that these are cases coming to the attention of a single private agency in a single country in the first ten years of the society's existence, and reports that the same society in twenty-nine years, or up to 1913, had cared for 2,101,130 children, an average of about 75,000 a year, the number for the last year being 159,000. What must be the condition where no such societies exist, and what must still be the sum total of childhood's suffering throughout the world in this enlightened age? The one hopeful feature of the situation is that there are anywhere such societies as this one, and that there is an awakening conscience throughout the civilized world.

There has often been a brighter side of the picture. Chamberlain (5), himself a lover of primitive man, as every deep student of anthropology is, finds much that is pleasing in the attitude of the simple savage toward his children.

Even Payne, the total effect of whose recital is such as we have given thus far, finds the silver lining behind the dark clouds of superstition in every age. He admits "among the lowest of the tribes an affection for their young, once it has been decided that they are to be allowed to live" (25, p. 44). Children were better treated by the ancient Egyptians than by any other peoples of that early day, due perhaps to matriarchal tendencies, to the fact that children were supposed to be under the protection of certain goddesses, to an early belief in a hereafter, and to more favorable economic conditions than prevailed generally. The fabled Romulus, as early as the eighth century B.C., is said to have initiated in Rome a legal movement to compel citizens to allow all normal children to live until they were three years old, and to rear all healthy males and at least one female child (25, p. 212). He also required that five neighbors must be called in to help decide the child's fitness to live. Strange as this may seem to us, it was a great humane movement for that day. After the reforms of Augustus and Nerva conditions were much improved. Subsidies were even granted by the State to poor parents, and it is said that in the year 100 A.D., as many as five thousand children, one tenth of them girls, were receiving State aid. With the founding of Christianity began the "ceaseless war they waged in behalf of children" (p. 258). Payne is of the opinion that the assertion of the Christian Fathers that children had souls probably did more to stop the practice of infanticide than any other idea (p. 264). He quotes with approval the learned Clement of Alexandria to the effect that "Orpheus tamed the tiger by his songs, but the God of the Christians, in calling men to their true religion, did more, since he tamed and softened the most ferocious of all animals — men themselves" (p. 261).

The school and childhood. The suffering of childhood

has not all been at the hands of the home and those of industry. The school has contributed its share. One or two glimpses at the attitude of earlier days must suffice as a basis for contrasts which the reader may easily make for himself, or he may read those of Swift (32, chap. 3), from whom the following quotations are taken:—

It is not so very long ago, as history measures time, that a Suabian schoolmaster pointed with pride to the results of his fifty-one years of teaching. He had given "911,500 canings, 121,000 floggings, 209,000 custodes, 126,000 tips with the ruler, 10,200 boxes on the ear, and 22,700 tasks by heart." It is also recorded to his credit that "he had made 700 boys stand on peas, 6000 to wear the fool's cap, and 17,000 hold the rod" (p. 95).

Evidently these scholarly duties formed an important part of the teacher's task. The words which Crabbe puts into the mouth of his schoolmaster represent something of the same attitude:—

"Students like horses on the road,
Must be well lash'd before they take the load;
They may be willing for a time to run,
But you must whip them ere the work be done;
To tell a boy, that if he will improve,
His friends will praise him, and his parents love,
Is doing nothing — he has not a doubt
But they will love him, nay, applaud without;
Let no fond sire a boy's ambition trust,
To make him study, let him learn he must" (p. 95).

Every one is familiar with one or more of the twenty-eight schools so vividly described by Dickens. The pictures may be somewhat overdrawn, but it is not difficult for one familiar with the history of the child to believe that the incidents depicted were essentially true to the facts. They typify an attitude of mind toward children and reveal the conception of the nature of childhood current in that day and age. The schoolmaster shared in the belief

of these earlier ages that childhood and youth were naturally bad and in need of total reformation, a conception, it is needless to say, which had arisen from philosophical theorizing rather than from scientific study of children.

In spite of what has just been said, it should not be forgotten that the necessity of an understanding of child nature was recognized by a few great minds at a much earlier period. Even as early as Plato one finds in his *Republic* a description of those elements of human nature for which it is the function of education to provide nurture. Plato was one of the first to insist that systematic education cannot be intelligently undertaken by the State or by an individual until they know the nature and needs of the being to be educated. John Locke's *Thoughts on Education*, the first educational book which deals primarily with the physical, mental, and moral nature of the child, has for more than two hundred years been a stimulus to the study of children. In Rousseau's *Émile* we find the first strong plea for such study. "I wish," says Rousseau, "that some discreet person would give us a treatise on the art of observing children — an art which would be of immense value to us, but of which our fathers and schoolmasters have not as yet learned the very first rudiments." This plea, together with his educational dictum, "follow nature," almost justifies our strong tendency to speak of Rousseau as the John the Baptist of the child-study movement. How shall the teacher follow nature if he does not know childhood thoroughly? How shall he know child nature without studying it intensively? While Rousseau himself came very far from living up to his own ideals, he did more than any other one man prior to our own generation to stimulate an interest in the study of children. It is beyond our purpose to discuss the many similar contributions of such men as Pestalozzi, Froebel, Herbart, and

many others whose prophetic utterances and work paved the way for the epoch-making researches into child nature carried out in our own day. It must suffice to say that the latter could hardly have been conceived and carried out without the former, for revolutions are seldom wrought in a day.

The study of children. Organized, systematic, scientific study of children is a thing of yesterday. The reading of history, literature, of even the history of education prior to Comenius, must convince the reader that children as such had small place in the thought of the writers. Child life has never been held in proper regard. Even such attention as was paid to children in earlier times seems to have been with the thought of what childhood was to be rather than what it was in itself. With adults childhood was tolerated because it led to manhood and womanhood. The beauty and glory of childhood as such was little understood or appreciated.

That educational procedure should be based upon a thoroughgoing knowledge of the child to be educated should be a pedagogical axiom. Strangely enough, this principle is unrecognized by many teachers, is often ignored by educational writers, and in earlier ages was unknown to those who had most need of it. Many universities and colleges and even normal schools in America to-day still prepare (?) teachers without giving them specific training in the psychology and hygiene of childhood and adolescence. How little it was recognized that a knowledge of children is a fundamental necessity for the teacher, prior to the beginning of the child-study movement, may be judged by an examination of the topics which absorbed the interest of teachers in their educational meetings. The proceedings of our National Education Association show that a generation ago discussion rarely centered about problems

of child nature, but rather about the relative merits of the classical and scientific education, problems of administration, curricula, the needs of society, about what was to be made of children rather than what children were, how they thought, how they differed from adults, what rights they had, and how their interests and needs could be supplied.

Recorded observation. The first consecutive record of observed facts of child nature of which we have any information was Tiedemann's *Observations on the Development of the Minds of Children*, published in 1787, unless we except the simple notes made by Pestalozzi concerning his son in the year 1775. These were followed by somewhat similar studies by Lobisch (1851), Kussmaul (1856), and Sigismund (1859). With the publication of Preyer's *Mind of the Child* in 1881, often spoken of "as the model record," a new standard was set for studies of this type and a new impetus given to the interest of people generally in the psychology and physiology of infancy. In America, during the closing decade of the nineteenth century, a number of studies of infancy inspired by that of Preyer were made by American women, the most notable being Miss Shinn's study of her niece, of which she has given us the most popular account in her *Biography of a Baby* (28). There have been a number of similar studies recently, and especially has there been a tendency to intensively study certain aspects of infant development; for example, the study of the development of speech, discussed farther on in this book. There is room for many similar studies, for there are many unsolved problems, as one may learn from examination of one of the more recent studies of this type — *Moto-Sensory Development*, by Dearborn.

The isolated, individual, and more or less sporadic studies of infancy of which we have spoken, would never alone have developed a science of child life. The real history of

“child study,” therefore, begins with the organized movement for the study of great numbers of children by a great number of workers. This movement, in the midst of which we now are, scarcely more than covers the lifetime of most of those who will read this book. Few attempts have as yet been made to write a historical sketch of the movement. The chapters in Gesell (9) and Claparède (6) are the most satisfactory brief accounts so far. It is naturally difficult to evaluate at its true worth a movement which is barely beginning to make history. We here present only a brief epitome of the most important events.

The organized movement for “child study,” of which G. Stanley Hall is the “Father,” was preceded by several noteworthy individual studies. In his classic study of *The Contents of Children's Minds on Entering School*, begun in 1880, Hall followed the example of studies made in Berlin as early as 1869, when “the new psychology” was just beginning to arouse enthusiasm. This investigation, however, is a landmark to be remembered as the first piece of study of the minds of a group of children ever made in this country. The study attracted considerable attention at the time, and stimulated such work as that of Russell, president of the Worcester Normal School, who in 1885 began the first systematic effort to collect continuously, with the aid of his students, observations of the interests and activities of children. This interesting effort was kept up all through the years that President Russell remained as head of the institution. The material collected during some twenty-five years, amounting to several tons of papers, was recently donated to Clark University, where use of it is to be made under Dr. Hall's direction. These are typical early pieces of work.

Societies. Not until 1893, at the time of the International Congress on Education, held during the progress of The

World's Columbian Exposition at Chicago, was any general enthusiasm aroused for "child study." At that time Hall addressed a small company of people on the subject, and organized The National Association for the Study of Children. A "Department of Child Study" of the National Education Association was organized the same year. These were rapidly followed by the organization of numerous State societies, and many local associations of groups of teachers and parents.

The first State society, and the most successful one, was the Illinois Society for Child Study, organized in 1894, largely on the initiative of Professor W. O. Krohn, of the University of Illinois. With him were actively associated such educational men as Colonel Parker, C. C. Van Liew, C. A. McMurry, and others. This society undertook a rather ambitious program, including both practical and scientific aims. For several years it published quarterly as its official organ the *Transactions of the Illinois Society for Child Study*, in which several original studies of some importance were reported. It also organized local round tables in various cities, and in other ways did much to popularize the movement. The society attained the largest membership of any of its kind, reporting a total of sixteen hundred in 1898, including representatives from most of the States, from Canada, England, Scotland, one from South Africa, and one from Japan.

Societies were organized after the same general plan in Iowa (1894), in Minnesota (1895), in Ontario (1895) as a section of the Educational Association, and in Nebraska, Missouri, Indiana, and Kansas (1896). Beginning in 1895, child study was conducted as a feature of the work of the Department of Public Instruction in New York State. None of these societies, however, continued as such for more than a few years, but they did give considerable

impetus to the movement for scientific child study, and especially to that for child welfare.

Proceedings. The closing decade of the nineteenth century was the period of great popularity for the new movement. The nature of the work done during this period, the methods employed, and the aims which were dominant may best be judged by an examination of the volumes of the *Child Study Monthly*, or those of the *Transactions of the Illinois Society for Child Study*. These and other journals of the period are filled with observational, reminiscent, direct-question, and questionnaire studies. Statistical treatment of the data presented often tended to give the appearance of exactness and finality to reports made upon the most intricate problems of child nature by persons ill-prepared to undertake such work. The definitely practical aims which most students cherished encouraged rather than restrained the tendency to hasty generalization. The contention of Barnes (1, p. 5) that "child study" was not a pure, but rather an applied, science, and the oft-repeated statement of many of the State societies that they had no desire to have their work considered pseudo-scientific, did not wholly succeed in preventing the popular mind from so considering it. This fact tended to alienate the more scientific students, and the popularity of the movement as such waned as rapidly as it had arisen.

It early became evident that a real science of childhood was needed, that such a science could not be built in a day, that its methods must be exact, its investigations painstaking, its workers well trained, and its conclusions well tested. Fortunately the movement has not had the kind of popularity in recent years that it had in the nineties. But, however much we may criticize some of the work of this early period, we must not fail to recognize the lasting contribution we unquestionably owe to those who pioneered

in this difficult field in these early years. The child has been raised to prominence. Parents, teachers, homes, churches, schools, and people generally have been brought to a recognition of the value and necessity of a scientific study of child life as never before in all history. We are now at the threshold of a most hopeful period. More scientific aims, more refined methods, and more carefully trained men and women as investigators of child life dominate the work of the present. The twentieth century, if it shall be in fact as it has been called, "The Century of the Child," will be so largely as a result of the impetus given to its workers by the early "child-study movement."

The movement abroad. The child-study movement has not been wholly confined to America. A group of British teachers, upon their return from the International Congress on Education at Chicago, founded, in 1894, the British Child Study Society. *Child-Study*, formerly *The Paedologist*, is their official publication. Poland has had an active Société polonaise pour l'étude de l'enfant since 1897. Germany founded at Berlin, in 1899, the Verein für Kinderpsychologie. France has had, since 1900, La Société libre pour l'étude psychologique de l'enfant. Several societies with similar aims have existed in Austria-Hungary since 1903. Individual societies for the study of child psychology, child hygiene, and especially for the study of experimental pedagogy, in Serbia (1906), Russia (1906), Switzerland, and Japan (1890), and several other countries, which have no organizations or societies for the furtherance of researches in child life, have done notable work. Important contributions have come from Italy, Holland, Bulgaria, Roumania, Sweden, Spain, Norway, Denmark, and the Argentine Republic. The last mentioned had a national congress on child welfare in 1913, and in 1915, at the celebration of the centenary of her independence, held

the First American Congress for the Child at Buenos Aires, where addresses were given and conferences held on a wide variety of topics. An exposition was also held in conjunction with the discussions. It will thus be evident that the recognition of the need for a closer study of children, and the purpose to make such study, have become world-wide.

Journals. Beginning for the most part early in the closing decade of the nineteenth century, a number of journals devoted in whole or in part to the various phases of child life have been established. *The American Journal of Psychology* (1887), and especially the *Pedagogical Seminary* (1891), both edited by Hall, have contained the results of most of the researches conducted by himself and his students, as well as by many others. The *Pedagogical Seminary* contains many of the early questionnaire studies, a number of which have been the basis for books. These journals still perform a very notable service. The *Child Study Monthly* (1895), *Barnes's Studies in Education* (1895-96), the *Journal of Adolescence* (1900), *Paidology* (1901), and *The Transactions of the Illinois Society for Child Study*, all of which belong to the period of first popular interest, have now been discontinued. In their place we have *The Journal of Psycho-Asthenics* (1896); *The Training School* (1904), devoted to the problems of the feeble-minded; *The Psychological Clinic* (1908), devoted primarily to problems of exceptional children of all classes; *The Journal of Educational Psychology* (1910), which furthers the same ends, and especially those of experimental education; and such journals as *The Playground* (1907) and *The Journal of Delinquency* (1916), which owe their existence to the rapid increase of knowledge of and interest in child welfare. It is beyond our present aim to name the very many excellent periodicals of other countries now devoted to the same ends. We can merely say that the quantity and quality

of such publications are wholly without parallel in any other age or period.

Beginnings in child-welfare work. In the introduction to his *Preventive Treatment of Neglected Children* (18), Hart gives us a chronological epitome of the steps by which in the United States we have come to give something like adequate attention to the needs of child life. He finds that the beginning was made as early as 1660 in the legislation in Massachusetts, providing apprenticeship for orphans and homeless children, and which enabled many such to grow up to be useful citizens in good homes. Sixty-nine years later (1729), the first private orphanage, the Ursuline Orphanage at New Orleans, was established. Sixty-one years more bring us to the first public orphanage established at Charleston, South Carolina (1790). Thirty-four years later (1824), was established the New York House of Refuge, which became the forerunner of the juvenile reformatory institutions now found in almost every State of the Union. In 1848 the Massachusetts School for Idiotic and Feeble-minded Youth began the movement for the care of these unfortunates now (1914) represented by no less than sixty-three similar institutions under public and private support in thirty-three States in this country. From 1850 to the present so many similar projects have been undertaken that space forbids mention of more than a few of the most significant ones. Boston established the first public playground under direction, in 1868; Salem the first boys' club, in 1869; Massachusetts the first separate court for children's cases, in 1870; in 1872 the National Conference of Charities and Corrections was organized; New York had the first social settlement, in 1887; and Illinois the first "juvenile court" law, in 1899. We are only now well started on the kind of protective work that should logically have been first undertaken. Dr. Hart well

shows that as usual the chronological order is quite different from what the logical order should have been. Prevention, however, is becoming the slogan of many of the newer organizations.

Recent movements. Of the most fruitful and promising of recent tendencies a few typical ones may be mentioned. Psychological clinics, begun as early as 1899 by Witmer, are becoming a feature of the work of public school systems, university and normal school departments of psychology, institutions for defectives, delinquents, and other special classes. The Child Welfare Conference, called by President Roosevelt in January, 1909, at Washington, has borne fruitful results in improved child-labor legislation and in other ways. The Child Conference for Research and Welfare, called by President Hall at Clark University, in July, 1909, and which effected a permanent organization with annual meetings, was the crystallization of the feeling of many scientists and practical workers that the time had come for greater coöperation, better mutual understanding, and more concerted effort by workers in every field in furtherance of both scientific study of and practical work with children. The establishment, in 1910, of the Children's Institute, at Clark University, is a further tangible result of this same feeling, and gives us an institution, such as exists nowhere else in the world, whose business it is to collect, increase, and disseminate scientific knowledge of childhood. Its work covers a dozen departments, and it purposes, among other things, to compile or outline the history of each class of society or institution having to do with children, to find in the voluminous literature scientific knowledge valuable in various types of social work, to coördinate the work of scientists and social workers to the mutual benefit of each, and to offer courses, conferences, or lectures for the scientific and practical training

of social workers of all classes. The plan of holding child-welfare exhibits, begun in New York City in 1910, and followed by Chicago in 1911, Kansas City in 1911, Baltimore, Atlanta, and numerous other cities, and, in 1915, made a feature of the great expositions at San Francisco and San Diego, has been a most effective means of disseminating information concerning present efforts and needs in child-welfare work.

Perhaps most significant among recent events was the establishment of the Federal Children's Bureau, in 1912, under the Department of Labor at Washington. This came after years of effort and repeated failures, and represents the awakening of the National consciousness to a recognition that children are as worthy of study and of protection as are sheep, cattle, horses, or hogs. The bill establishing the bureau authorizes investigations and reports "upon all matters pertaining to the welfare of children and child life among all classes of our people" and especially designates ten important lines of study. The bureau is receiving more generous support than at first, and, in spite of the inadequacy of its appropriations, has already made several notable investigations and reports on infant mortality, the birth rate, prenatal care, birth registration, and related topics. As a source of information and an agency for uniformizing laws relating to children in the various States its service is destined to be one of increasing value.

Most encouraging signs for the future welfare of children are to be found in the very rapidly increasing interest of many of our States and cities. Within the past five years child-welfare commissions, under various names and with somewhat different functions, have been established by legislative enactment. Those of Minnesota, Oregon, New Hampshire, Ohio, Texas, and Missouri are typical. The Russell Sage Foundation is conducting surveys of

child-helping institutions in various States and cities. The National Child Welfare Exhibit Association, Inc., of New York, is furthering an educational campaign in welfare work and needs. Many cities are at work reorganizing or have reorganized their social agencies for more effective work. So rapidly are all these things being done that anything further we might say would soon be out of date.

Research laboratories. Our great universities are opening up promising new lines of service and of research. The University of Kansas has for several years maintained a professorship in child welfare; which is doing much in the interest of all the children of the State. The Bailey and Babette Gatzert Foundation for Child Welfare, established in 1910, and in 1915 made a separate department of the University of Washington, maintains a psychological clinic, assists local welfare organizations throughout the State, and conducts research work in child psychology. The Research Laboratory of the Buckel Foundation at Stanford University (1915) has already been able to make valuable contributions to the coming science of intelligence testing. Just as this book goes to press there is being established at the University of Iowa what might well be taken as a type of institution which all our State universities should establish. The Legislature of the State has made an annual appropriation of twenty-five thousand dollars for the establishment of a Child-Welfare Research Station. The purposes stated in the bill are "the investigation of the best scientific methods of conserving and developing the normal child, the dissemination of the information acquired by such investigation, and the training of students for work in that field." As outlined by Dr. Seashore, under whose direction the work is being initiated, there will be six divisions of research undertaken: (1) heredity and prenatal care; (2) nutrition of the child; (3) preventive medi-

cine; (4) social surveys and social policy ; (5) education and morals; (6) applied psychology. The plan is to devote the facilities of the station to the study of children under school age, a period which, except for the few studies of infancy, some medical research in hygiene, and the recent work of our Children's Bureau is, in large part, practically a *terra incognita*. The launching of such a movement, therefore, is fraught with tremendous possibilities for good. In this new venture the University of Iowa, which has already rendered notable service to the people of the State by providing expert vocational guidance in music, plans to extend and broaden the field of its practical and patriotic service.

There are now more than ninety types of organizations working for the welfare of children, in one way and another (17, vol. 2, pp. 74, 75). The rapid spread of health work in public schools and institutions, including medical, dental, and psychological clinics; the phenomenal spread of the playground movement over the country; the development and spread of the juvenile-court idea; the radical reorganization of work for the feeble-minded, delinquent, crippled, blind, and deaf of our public schools; improved legislation in the interest of children; and many other reforms bear witness to a general awakening of public interest which in no small degree has been the direct outgrowth of the earlier "child-study" movement.

QUESTIONS AND TOPICS

1. What will be the chief values of a science of childhood?
2. Cite evidences of progress toward such a science.
3. What proofs can you give from the history of your own community or state of the growth of humanitarianism in relation to children?
4. Make a list of the child-welfare agencies of your community, and find out the approximate length of time they have existed.
5. What has led to the establishment of these agencies, how are they supported, and what have they accomplished?

6. Talk with your parents, grandparents, and other older persons about their teachers and early school experience. Does comparison with your own reveal any radical changes? For better or worse?
7. Formulate the chief impressions a study of the history of the child and of child study makes upon you.
8. As your study proceeds, form as definite an idea as possible of the fields and problems of child psychology which most urgently demand further study.

SELECTED BIBLIOGRAPHY *

1. Barnes, E. "Methods of Studying Children"; in *Studies in Education* (1896-97), vol. 1, pp. 5-14.
2. Barus, A. H. "Methods and Difficulties of Child-Study"; in *Forum*, vol. 20, pp. 113-19.
3. Bonger, W. A. *Criminality and Economic Conditions*. (1916.) 706 pp.
4. Chrisman, O. "Child-Study; A New Department of Education"; in *Forum*, vol. 16, pp. 728-36.
- *5. Chamberlain, A. F. *The Child and Childhood in Folk Thought*. (1895.) 464 pp.
- *6. Claparède, Ed. *Experimental Pedagogy* (1910), pp. 13-37.
7. *Cyclopedia of Education*. Paul Monroe, editor. Vol. 5, pp. 866 ff. Historical and Biographical.
8. Drummond, W. B. *An Introduction to Child-Study* (1905), pp. 1-7.
- *9. Gesell, A. L., and Gesell, Mrs. B. C. *The Normal Child and Primary Education* (1912), pp. 3-28.
10. Hall, G. S. "Child-Study: The Basis of Exact Education"; in *Forum*, vol. 16, pp. 429-41.
11. Hall, G. S. "The New Psychology as a Basis of Education"; in *Forum*, vol. 17, pp. 710-20.
12. Hall, G. S. "Child-Study and its Relation to Education"; in *Forum*, vol. 29, pp. 688-702.
13. Hall, G. S. "Child-Study at Clark University"; in *Am. Jour. Psy.*, vol. 14, pp. 96-106.
Contains bibliography of questionnaire studies at Clark University.
14. Hall, G. S. "Recent Advances in Child-Study"; in *Ped. Sem.*, vol. 15, pp. 353-57.
15. Hall, G. S. *Proceedings of the Child Conference for Research and Welfare* (1909), vol. 1, pp. ix-xvi. Preface.
16. Hall, G. S., and others. "General Outline of the New Child-Study Work at Clark University"; in *Ped. Sem.*, vol. 17, pp. 160-228.
Contains classified bibliographies, and statement of the purposes of the Children's Institute.

* Note. The references starred in each bibliography are likely to be of especial value to the beginner in securing a general view of the topic.

17. Hall, G. S. *Educational Problems*. (1911.) 2 vols., 710 pp. and 714 pp.
18. Hart, H. H. *The Preventive Treatment of Neglected Children* (1910), pp. 1-8.
19. Holmes, A. *The Conservation of the Child* (1912), pp. 15-31.
An historical sketch of the work with the feeble-minded.
20. Kidd, D. *Savage Childhood*. (1906.) 314 pp.
21. Kirkpatrick, E. A. "Point of View of Genetic Psychology"; in *Jour. of Educ. Psy.*, vol. 1, pp. 76-82.
22. Misawa, T. *Modern Educators and their Ideals* (1909), pp. 267-90.
23. Monroe, W. S. "Child-Study in Europe"; in *Ped. Sem.*, vol. 6, pp. 372 ff.
24. Monroe, W. S. "Child-Study in Europe"; in *Ped. Sem.*, vol. 8, pp. 511 ff.
- *25. Payne, G. H. *The Child in Human Progress*. (1916.) 400 pp.
26. *Pedagogical Seminary*. See indices under "Child Study."
27. Russell, E. H. "Biographical Sketch of President Hall"; in *Am. Jour. of Insanity*, vol. 53, pp. 317-22.
28. Shinn, Miss M. W. *Biography of a Baby* (1900), pp. 1-19.
History of baby biographies.
29. Smith, Miss T. L. "Child-Study at Clark University"; in *Ped. Sem.*, vol. 12, pp. 93-96.
30. Smith, Miss T. L. "The Development of Psychological Clinics in the United States"; in *Ped. Sem.*, vol. 21, pp. 143-53.
31. Stratton, G. M. *Experimental Psychology and Culture* (1903), pp. 1-16.
32. Swift, E. J. *Mind in the Making*. (1898.) 329 pp.
33. *Transactions of the Illinois Society for Child-Study*. (1895-1900.)
Record of the work of this society.
34. *United States Commissioner of Education, Report of*. (1897-98.) Vol. 2, pp. 1281-1384.
35. Villa, G. *Contemporary Psychology* (1903), pp. 8-62.
36. Wilson, L. N. *G. Stanley Hall*. (1914.) 144 pp.
Contains a bibliography of President Hall's writings to date.
37. Wiltse, Miss S. E. Articles dealing with the history of child study. *Ped. Sem.*, vol. 3, pp. 189-92; vol. 4, pp. 111-25. See also *Proc. N.E.A.* (1896), pp. 837-43.

CHAPTER II

METHODS OF SCIENTIFIC STUDY OF CHILDREN

The value of scientific method. All sciences have been built up by the use of systematic observation and experimentation. The science of childhood can be no exception. The study of children by the methods of modern science has now been seriously undertaken. This new and valuable science will advance rapidly only when all who have to do with children abandon preconceived notions about them, and once for all give up hope of understanding them by mere intuition, by armchair theorizing, or by empirical methods alone. Nothing but the most careful, unbiased, systematic, and persistent study of facts will lead to scientific knowledge. The security and the value of our knowledge, therefore, depend clearly upon the qualitative validity of the methods of observation, research, and experimentation used in the amassing of that knowledge.

Methods most used. Some idea, then, of the methods that have been generally used in the study of children so far is needed by all who read and use the facts that have been accumulated by them. It is always true that in the beginning of any new line of research, methods are used which the light of experience proves to be of little value. Experience also leads to the refinement and improvement of methods. So, while most of the methods used in the study of children have yielded some results of value, they are not all of equal merit. It is also true that certain methods lend themselves very well to the accomplishment of one kind of result and very poorly to others, and that a method may be well and wisely used, or it may be used

carelessly and unwisely. We have not the space to enter into elaborate criticism or evaluation of all of the methods, but must content ourselves with a brief sketch of a few of those that have been more widely used, and the purposes they are designed to serve.

Biographical. The first scientific studies of child life which have come down to us consist of careful, consecutive, methodical records of direct observations of the time of appearance, the order of development, the nature and relationship of instinctive tendencies, of physical traits, of mental, moral, and social capacities and activities of individual children. The method need not be, but has for the most part been, confined to the study of infancy. Most of the studies so far made by this method do not carry us beyond the third year of the child's life, chiefly no doubt by reason of the difficulty attendant upon carrying them further. The method is seen at its best in the studies of Preyer, Miss Shinn (37), and Dearborn (12) to mention only three, each of which is superior in its own way. Every student of infancy should know at least one of these studies and the contribution it makes to our knowledge of infancy.

The scientific value of such studies depends very much upon the scientific preparation of the observer. The observer must possess those characteristics of the scientist so well summarized by Drummond (13), — a passion for facts, a questioning attitude, a controlled scientific imagination, boldness, accuracy as an observer, be possessed of that general intelligence which gives sanity and caution to interpretations, and must be free from preconceived notions.

The general procedure in such studies of infancy as those to which reference has been made has been in the main that of careful, systematic, consecutive observations of individual infants, with prompt record of all observations in the form of notes which are later collated and interpreted. To some

extent the observation of spontaneous developments has been supplemented by experiments designed to test sensory capacity, power of discrimination, ability to recognize, choice of color, volitional control, and like capacities.

The method has already yielded results of both theoretical, scientific, and practical value. There is room for many more such studies and, quite apart from the hope of making any scientific contribution, the carrying out of such a study with Preyer or Shinn as a model is a fascinating one for any parent and one fruitful in results to any person intelligent enough to make it. The chief limitation of the method as a means of building up a science is its slowness. The fact that it is an individual method, and that the limitless scope of the observations included make it exceedingly difficult to use as a child grows older, have in practice been the important reason for its restriction to studies of infancy.

Direct questioning. Hall's classic study of the *Contents of Children's Minds on Entering School* is perhaps the best illustration of a fruitful use of the method of the direct question. In this study there is not only a clear statement of the procedure, but also a good treatment of the necessary caution which must be observed in its use. The children were asked singly, or by turn in small groups, to respond to simple, direct, factual questions concerning the common things of life about which they were supposed to know something. Use was made of one hundred and twenty-three questions such as: "Have you ever seen a cow, pig, sheep, hen, bee, frog, ant, robin?" "Have you ever seen apples on a tree, grapes on vines, wheat or potatoes growing?" "Have you ever seen a hill, brook, woods, an island, a river?" "Where does milk, butter, meat, leather, cotton, wool, come from?" "Show me your elbow, cheek, forehead, ankles, knee, throat, ribs." "Have you ever seen a watchmaker, bricklayer, shoemaker, farmer at his work?"

Questions to determine the child's knowledge of the numbers three, four, five; of the forms triangle, square, circle; the colors green, red, blue, yellow, etc. "Can you name three things that it is wrong to do? Three things that it is right to do?" Such questions were often followed by such others as seemed necessary to determine with fair accuracy whether the child had or had not any real concept. The results were recorded and later tabulated and treated statistically. By such a method inventories of the content of children's minds are secured and some light is thrown on the nature of their concepts, knowledge, ignorance, experience, training, and their general intelligence.

In a similar way classes of children may be asked to write their individual answers to set questions as a regular composition exercise and the papers gathered, analyzed, the results tabulated, treated statistically, and interpreted. Barnes (3) made very extensive use of this method in the early nineties using such questions as: "What person of whom you have ever heard or read would you most wish to be like? Why?" "If you could go any place you wish where would you like to go? Why?" "What do you mean by each of the following words: monk, peasant, emperor, armor, nation, school?" "Describe the prettiest thing you have ever seen and say why you thought it pretty." By such questions some idea can be had of the children's degree of imaginativeness; the ideals they hold and the change in them with age; the nature of their dominant interests; the content of the words they use; their ideas regarding punishment, ethical problems, theological notions, and many more. Of the Barnes studies that of *Children's Ideals* is illustrative of the best results secured by his use of the method of the single or set question.

The method has decided limitations, and has been much abused. Much depends on the tact of the questioner, upon

the uniformity of procedure used by different questioners whose results are to be compared, and especially upon the nature of the questions asked. The well-known suggestibility of children, their desire to please, the desire of some to startle or shock the investigator, and many other complicating factors often enter to make the value of the results questionable. In spite of its very evident defects a good deal of valuable insight into certain phases of child thought, feeling, and activity has been gained by this method. Much valueless material has also been collected, and no doubt much that is actually misleading rather than enlightening. Studies by this method should, therefore, be read critically.

Clinical. The term "clinical method" was borrowed from the medical school, and was first applied by Witmer (44) to designate a method he was using at the University of Pennsylvania. The method aimed to secure as complete a picture as possible of all pertinent facts concerning the heredity, family, and personal history, and the present physical, mental, and moral traits of a single child. The method was used at first, and to a considerable degree is still used, most commonly in the study of exceptional and unusual children, although there is no necessary reason why it should be so restricted. The various phases of the physical examination were often conducted by dentists and physician specialists in the respective fields of eye, ear, nose and throat, nerves, etc. The mental examination was sometimes made in the presence of a class studying such problems, — hence the name clinical, — although this is now generally admitted to be undesirable, and is not in any way essential to the method. The method is coming rapidly into vogue, especially since the recent rapid advance and extension of mental and intelligence tests which have now risen to such prominence as to deserve the separate treatment which we attempt a little farther on.

There seems to be just now a strong tendency toward the training of clinical experts who shall be qualified to make both physical and mental examinations. There is a rapidly growing field, for persons so trained, in juvenile courts, reformatory and penal institutions, institutions for mental deficients, in business establishments, and in school systems where the fullest possible knowledge of the present traits and capacities of an individual need to be known for practical purposes and need to be determined in a short space of time.

Questionnaire. A questionnaire presents for answer a large number of questions on a single topic or group of closely related topics, often arranged under several separate heads. Sometimes the questions call for direct, first-hand observation of children, but most often for reminiscences of one's own earlier thoughts, feelings, ideas, and observations.

The questionnaire method as a means of research in child study was introduced into this country and was most widely used, and, according to Claparède, abused, by President Hall. Several hundred questionnaires have emanated from Clark University, most of them written in whole or in part by Dr. Hall. This was the popular method during the last decade of the nineteenth century. An astonishing amount of work was put upon many of the studies of that period. Many volumes are required to report the findings. The method is still used to some extent, but has been largely superseded.

There is a strong tendency in recent years to criticize severely, if not to discredit entirely, much of the work of this class. Claparède (10) and Thorndike (40, p. 32) present the ultra-critical view. Smith (38), Gault (15), and Chambers (24) may be consulted for a more impartial, or perhaps we should say favorable, view as to the use of questionnaires. Since the method played a very important rôle in the early history of the child-study movement, a brief

résumé of the criticisms and justifications of its use seems necessary as a guide to the reading of literature of that period, and further, as Thorndike (40, p. 37) states it, "respect for their aim if not for their results, and for his [Hall's] ability if not for his method, requires due consideration for these reports."

The value of a questionnaire study depends upon, (1) the nature of the topic to be investigated; (2) the care and skill with which the questions are formulated; (3) the composition and representative character of the group of persons answering; (4) the honesty and conscientiousness of those who answer; (5) the scientific ability of the investigator who attempts to interpret the data or to draw deductions from it; and (6) the kind of use that is to be made of such deductions.

Against the questionnaire it has been argued that the method is unreliable, especially in unskillful hands; that it is inaccurate, since hearsay is often confused with fact, and reminiscence with direct observation; that it too often suggests what the questioned is expected to say; that a cross-sectioning of the physical and mental nature of many children gives us no accurate picture of the development of any single child; that "the progress from a set of statements about individuals to a statement about a group including them is by no means a matter of simple addition" (40, p. 36); that a thousand statements, if they are erroneous, can bring us no nearer the truth than one; that often the statements made by the group studied do not represent the true state of affairs within the group because, (1) not all those questioned answer; (2) those who have usually answered have been select groups (normal school students, mostly young women); and (3) even these have often answered the questions as an academic task. The most valid general criticism of these studies is that many of them

have been carried through without due regard for these serious sources of error which are unavoidably to be encountered.

Most of the above criticisms have been answered with more or less success. It is urged that, upon selected topics, qualitative material and even statistical material of real value can be collected; that the unreliability, inaccuracy, and undue suggestiveness of the questionnaire are in part remediable defects; that even the opponents of the method admit that some real contributions to our scientific knowledge have been made; and that some of the criticisms of this method have almost equal weight against other methods. Those who defend the questionnaire contend, with considerable success, that the studies made by this method have performed several very useful functions already, even if it should be granted that its day is largely past. Not the least among these services rendered the science of child life are the following: A wealth of concrete data on all phases of childhood and youth has been gathered which could not have been collected so quickly, if at all, in any other way; innumerable questions, unthought of before, have been opened to investigation by other more refined methods; and many of the studies have revealed the existence of age boundaries and general characteristics of stages of development in child life quite unrecognized before. In general the studies by this method have played no insignificant part in the movement which has taken psychology from the realm of the abstract and brought it into vital relation with life and with education. It is by no means insignificant either that the numerous studies made under his direction have furnished Dr. Hall a tangible basis for the construction of the most interesting, stimulating, vitalizing, and suggestive educational philosophy of modern times, a philosophy which finds its basis in the laws of child growth and

development, a philosophy which puts the child in the center, a philosophy which is fundamentally genetic and evolutionary. It is perhaps not too much to say further that, with due regard to the serious limitations of the method, it has been a means of arousing popular interest in child life and welfare to an extent that no other method could have done in the same length of time.

The method has been used to gather data on almost every conceivable phase of the innate tendencies, emotions, mental and physical traits and capacities, motor abilities, interests, ideas, moral and religious responses and attitudes, etc., of children. Questionnaires on such subjects as play, collecting, dolls, truancy, ownership, hydro-psychoses, dendro-psychoses, crying and laughing, creeping and walking, language, fear, anger, pity, love, jealousy, reminiscence, memory, imagination, imitation, suggestion, obstinacy, lies, obedience, conversion, interests in pictures, words, flowers, nature, pets, reading and scores of others have been widely circulated, responded to, and the data so gathered studied and interpreted.

It is difficult to estimate judiciously the ultimate contribution of the questionnaire method to the science of the child, but it is safe to say that no truthful history of this growing science can ignore the contributions we have mentioned. If in this book somewhat less attention is given to the studies of this type than some of the earlier books have given, it must not be taken to indicate that we consider them valueless, but rather that we believe that the best contributions they have made have become common knowledge, and that now more time and space must be given to the newer and more scientific methods and their results.

Statistical. Whenever the data of child study lend themselves to quantitative treatment the statistical method is employed. The purpose of statistical treatment is the estab-

lishment of a quantitative science of the child. When norms, standards, and average deviations can be set up for all important physical, mental, and moral traits and capacities, they make for certitude in our understanding of and dealing with children.

For trustworthy statistical treatment of any data a few general principles should be had in mind. To reduce error to a minimum the greatest care and accuracy must be taken in gathering the data in the first place. The number of cases should be numerous enough to offset the disturbing effect in distribution of unusual and exceptional cases. In ordinary matters some hundreds or thousands of cases are needed for the establishment of conclusions that are expected to be of general use or applicability. On the other hand, statistical results may sometimes be misleading by reason of excess of numbers which tends to obscure important minor deviations. In such cases it is just as dangerous to have too many as to have too few data. Again, the cases should be typical and representative or non-selected, unless it is the effect of selection that is to be tested. It must be evident, then, that the value of statistical studies depends much upon the nature of the statistical material itself; upon the judgment and good sense of the scientist who uses it; and upon the purposes for which the results are to be used. There is no innate virtue in mere figures. Figures do not lie, but untruthful people sometimes mislead us with figures, and careless people often draw wrong deductions from them. All statistical studies should be examined in the light of the cautions we have cited.

Statistical terms. Three or four terms used in statistical studies need to be clearly understood. (1) The arithmetical *mean*, or average, is the commonest value sought, and is the best known. It is merely the result obtained by dividing the sum of all the values found by the number of cases. For

example, if 100 children are measured for stature, the mean height is obtained by dividing the sum of all the heights by 100. (2) The *median*, or middle value, is sometimes of more interest than the average. It is found by arranging all the values in the order of their occurrence from the lowest to the highest, and then by actual count the one standing in the middle is found, or, in case the number is even, the average of the two middle values is taken as the median value. This value may or may not coincide with the mean. In our illustration above we might in this case line up our 100 children in order, beginning with the shortest and ending with the tallest. Our median height would be the average height of number 50 and number 51. (3) The term *mode* is applied to the value that in any series occurs most frequently. If, for example, fifteen of our children were found to be forty-eight inches tall, and this height occurred two or three times as often as any other, then forty-eight inches is clearly the mode for our group which is, let us say, a group of eight-year-olds.

The statistical method has been widely used in the field of child study, and often, it must be admitted, in a way to give the appearance of scientific value to data which should not have been so dignified. With the growth of the tendency to use greater care in the choice of subjects for study, the refinement of statistical methods, and the critical reception which careless studies meet, reports of this kind now appearing are of a higher grade than formerly. In a quantitative science the method is indispensable. Constant reference will be made throughout this book to studies of this type, and for best results the reader should be familiar with such fuller discussions of this method as those of Titchener (41), Rugg (32), Rusk (33), or Whipple (43). Monroe (25) gives a simple and quite elementary treatment which teachers may find useful.

Parallel groups. Winch¹ and others have of late made considerable use of the method known as that of parallel groups. It is well adapted to the study of certain kinds of practical school problems, and, since it is comparatively easy to apply, it is likely to have more extensive use. Such problems as the relative merit of different methods of learning, of study, and of teaching and training, can be much more accurately determined by this method than by unverified opinion.

The method is used in two ways. In one it is essential to have two groups of children of approximately equal ability in the capacity to be tested. In the other, two tasks of equal difficulty must be devised. A preliminary test of the ability of a group of children in spelling, for example, is given under controlled conditions. On the basis of this test the pupils are divided into two groups of practically equal ability (so far as this capacity is concerned), by pairing two pupils of equal ability, putting one in group "A" and the other in group "B," till all have been placed. Then one may proceed, under any desired conditions as to time and procedure, to teach the two groups a list of one hundred difficult words, many of which they are known to be unable to spell correctly. If the method used with group "A" is entirely different from that used with group "B," but all other conditions are kept rigidly the same, one may in the end be able to draw some conclusions of value as to the relative merits of the methods employed. This can be judged by a final test, given at some time well after the completion of the test teaching. It is possible also to make from the results of the preliminary test two tasks of equal difficulty, in this case two groups of words, and then to teach the entire group of children list "I" by one method,

¹ Winch, W. H. "Experimental Researches on Learning to Spell," in *Journ. Educ. Psy.*, vol. 4, 525-37; 579-92.

and list "II" by another. The relative merits of the two methods may be thus quite well determined.

Studies of this type should be repeated often by the same and by different observers, with all conditions kept the same except the one being tested, before too much weight is attached to the results, for matters of this kind are usually exceedingly complex. Unquestionably, however, the use of such a method will ultimately throw much light upon the learning process, and will place teaching procedures upon a much more scientific basis than that upon which they rest at the present time.

Intelligence tests. Since the publication in 1905, by Binet and Simon, of their first series of graded tests of intelligence, a tremendous amount of scientific and popular interest has developed in the new method thus afforded. A great number of workers are devoting at least a part of their time to the use, improvement, revision, and extension of the Binet-Simon scales of 1908 and 1911, or to the perfecting of other similar instruments for the same purpose.

The object of such tests is to furnish a handy means by which, in a very short space of time, a psychological analysis can be made of certain significant capacities, so that the grade or level of the child's intelligence may be estimated. Binet's great contribution consists in his discovery of the possibility of constructing an age-grade series of tests. The tasks or performances, usually five or six for each year, are arranged in an increasing order of difficulty in such a way that a normal child should be just able to pass those of his own chronological age and those of the years below this, but not those above. The placing of the tests in the series is, of course, determined by actual trial with large groups of normal children, in short, it is an experimental scale. In choice of tests an attempt is made to select such as measure native ability, rather than the effects of training or scho-

lastic attainment. The tests are also so chosen that by their variety they explore all important phases of intelligence. They especially aim to test the common sense, adaptability, foresight, initiative, and judgment of the subject in meeting such situations as are called for in everyday life.

The tests are administered individually, and it is especially important that the child be in sympathetic *rapport* with the examiner, and that the examination be made under conditions that favor in every way the child's best effort and success. It has been found that the accuracy of the results of classification by means of such scales is definitely affected by the procedures followed in its administration, the method of scoring, the training and insight of the examiner, and by still other factors. A standard method of administration has, therefore, been perfected to reduce error to a minimum (39).

The measurement of intelligence (an accepted definition of which has not been agreed upon as yet) is by no means so simple a matter as the taking of anthropometric measurements, nor are any of the intelligence scales to be looked upon as instruments of precision comparable to the foot-rule or the standard scales for weight. It is frankly admitted by all that the intelligence scale has its distinct limitations. Its advocates do not claim that it gives a complete measure of any one of the intellectual capacities, such as memory, sense-discrimination, reasoning, and the like. Neither do they claim by its use alone to be able to give complete vocational or pedagogical advice. It is only claimed that a rather clear and definite notion of the child's level of intelligence can be arrived at, more readily and accurately than otherwise, by observing the combined functioning of his various mental capacities as he works out these tasks of known difficulty. While this is not the only measure that one would wish to have, it does furnish a ready means of insight into

one of the most important elements determining the child's capacity for school work, for vocation, his degree of responsibility for his own conduct and his ability to manage his own affairs with discretion.

It is too soon to give a final estimate of the value of this method. Opinions differ widely, but many consider it an epoch-making discovery. It has already come into very wide use in institutions for the feeble-minded, delinquent, and exceptional in public schools, and as an aid in vocational guidance. As a by-product of its use for practical mental classification a great deal of psychological insight into the nature and development of the mental capacities of children is already being gained. Its use has given to child psychology an exceedingly important and entirely new impetus which in itself is of tremendous value. The exact nature of the tests, the methods of their administration, their purposes, and the results of their use so far have been set forth so clearly and splendidly by Terman (39) that we need not dwell upon them further. All who are interested should read his account of the whole subject.

Interpretation. The interpretation of the results of observation and experimentation is fraught with no less serious difficulties than are the processes of discovery of the facts themselves. Some consideration of the chief sources of error is necessary for those who attempt original interpretations, and for those who merely hear or read the conclusions of others, so that neither may be unwittingly misled.

In the first place, it must be kept in mind that in a field so complex as that of human life, many errors are likely to creep into interpretation in spite of the greatest care, just as we have already shown they do into observation and experiment. It is well, then, that interpretations, inductions, and deductions be usually considered as tentative, and

that they be repeatedly verified before they are formulated into laws. There is peculiar danger of error in the study of the behavior and psychology of children. We are still inclined to do the very thing which for so long prevented the recognition even that a science of childhood was needed, namely, to think of child behavior and child thinking in terms of our own thinking and behavior. If child study has accomplished any one thing during its brief history, it is that it has proved the child to be not an adult in miniature, either physically or mentally, but a different being. His body is not merely smaller; it is different in every fiber. His mind is not merely quantitatively different; it is different in kind. His behavior not only concerns itself with different objective things, for the most part, but it is differently conditioned from within. One must not, we now know, hastily draw conclusions concerning the thinking, feeling, or doing of a child by introspecting upon one's own thoughts, emotions, or acts under apparently similar circumstances. Such a procedure is usually very misleading. In this connection the "doctrine of economy," long ago applied by Morgan to the study of animal mind, is undoubtedly a safe doctrine. "In no case," says Morgan (27, p. 53), "may we interpret an action as the outcome of the exercise of a higher psychical faculty if it can be interpreted as the outcome of the exercise of one which stands lower in the psychical scale." The neglect of this principle leads to the psychologist's fallacy, to the common error of attributing too much intelligence to the child and of expecting too much of him. This caution is a very necessary one, even if it is difficult to apply.

So closely are the higher forms of behavior linked with intelligence in our ordinary thinking that we are apt to be misled by the fact that some of the most perfectly adaptive forms of instinctive behavior seem to evidence a keenness of intelligence that is certainly not present. Here the principle

of the philosopher Descartes is of aid in interpretation. His belief was that apparently intelligent behavior in a limited field could not be taken as a sign of real intelligence, unless the general behavior evidenced the same apparent intelligence. If this be true, it may be briefly stated that lack of intelligent behavior is likely to be good evidence of lack of a corresponding degree of intelligence, but apparently intelligent behavior is much less certainly an index to corresponding intelligence.

Meumann has also given us a principle which is of assistance in judging correctly the progress of an individual under observation, or of estimating the probable capacities of groups at certain stages. If at a given stage a child has been judged to possess a certain trait or capacity, which later he is proved not to possess, we must judge ourselves in error in the earlier observation. Or, to state the principle positively, we may say that failure to show possession of a trait or capacity now (at say nine years) is evidence that it was not present earlier (at say seven years). This principle enables us to check up the accuracy of earlier observations and experiments in individual studies. It also serves as a counter-check in estimating the correctness of conclusions drawn in group studies.

Another frequent source of error is the argument, from teleological grounds, that because an act subserves a useful end, the actor must have been conscious of this end and have had it in view when the act was performed. This does not follow, and is especially misleading in the study of instinctive behavior. In this case advantageous acts may quite as well have originated by chance and have been perpetuated by natural selection.

Once more, to be strongly committed to a theory, such as the theory of physical and mental recapitulation, of culture epochs, the doctrine of catharsis, the doctrine of psycho-

physical parallelism, the doctrine of formal discipline, and the like, is quite likely to lead one, often quite unconsciously, to interpretations favorable to his theory and against opposing ones. In short, one needs throughout the scientific open-mindedness, reserve, and caution of a Darwin if one would avoid becoming narrow and opinionated.

Each of the methods we have outlined, and others of which we cannot here speak, has its place and use. Each has its limitations, which usually center in the human factors involved. Individual methods are slow and difficult. They do not readily furnish norms or averages, but they offer, perhaps, the richest field for future study. Group methods, on the other hand, make control of conditions difficult, complicate results, and allow many sources of error to enter. By means of them very rapid progress can be made in the solution of certain well-selected problems, if they are carefully used. For the purposes of individual and differential psychology they are unreliable and often misleading. Introspective methods have relatively little place in child psychology, which must continue to be largely observational and inferential, although we are learning that in certain fields a careful investigator can get more and better introspective results with children than was once thought possible. Laboratory methods are most valuable, but often require expensive apparatus and training in technique which, perhaps fortunately, restricts their use. The association and psycho-analytic methods are difficult to evaluate as yet in relation to child psychology. For this reason, and because most of the literature concerning them and most of the studies of children made by them are so far not yet available to English readers, we have deemed it unnecessary to attempt descriptions of them here. Our later chapters will illustrate the applicability of scientific methods to the study of the problems of child psychology, for an

understanding of which this brief sketch is designed to prepare the reader.

Recognition of the many difficulties and pitfalls incident to a scientific study of human nature is in itself one of the best evidences of progress toward the ultimate solution of the many unsolved problems concerning child life. Progress in the perfecting of the technique of method is being made very rapidly. Investigations are being planned and carried out more carefully than ever before, errors in earlier studies and interpretations are being rapidly checked up, scientists of recognized standing are attracted to the investigation of problems of child life as never before. In a word, we seem to be entering what should be the most fruitful period of research in child psychology that the world has ever known. Educational insight, pedagogical practice, judicial procedure, sociological theory, industrial betterment, and many other lines of human thought and endeavor should reap many a golden sheaf from the ripening field of child psychology.

QUESTIONS AND TOPICS

1. Select some child or group of children for first-hand study, so that you may verify or test as many as possible of the points brought forward in our discussion. Observe carefully the cautions suggested under the topic "Interpretation."
2. What evidences can you present that the assumption of a scientific attitude in the study of children has brought and will bring desirable results?
3. Note any changes in your own opinions and attitudes toward children, as your study of the science of childhood progresses.
4. Give an explanation and evaluation of each of the important methods discussed in this chapter.
5. State definitely the differences between the methods now used, and those used during the first twenty years of the child-study movement. Give reasons for the changes.
6. Explain the "law of parsimony" or "doctrine of economy."
7. Explain Meumann's principle.
8. Criticize the teleological argument.

9. State all the important characteristics of the scientific attitude as applied to the study of human nature.
10. Explain the three common statistical terms and apply them in an original illustration.
11. Read at least one questionnaire study and prepare a critical evaluation of it.
12. Discuss the purposes, values, and limitations of intelligence tests.

SELECTED BIBLIOGRAPHY

1. Baldwin, J. M. *Mental Development; Methods and Processes* (1894), pp. 36-49.
2. Barnes, E. *Studies in Education*. (1896-97.) "Methods of Studying Children"; in vol. 1, pp. 5-14.
3. Barnes, E. *Studies in Education*. (1896-97 and 1902.)
Both volumes illustrate in the main the use of the direct question method.
4. Binet, A., and Simon, Th. *Mentally Defective Children*. (1914.) 180 pp.
5. Bolton, F. E. "New Lines of Attack in Child-Study"; in *Proc. N.E.A.* (1902), pp. 703-10.
6. Bryan, W. L. "Systematic and Unsystematic Child-Study"; in *Proc. N.E.A.* (1895), pp. 412-18.
7. Bryan, W. L. "Scientific and Non-scientific Methods of Child-Study"; in *Proc. N.E.A.* (1896), pp. 856-60.
8. Burnham, W. H. "Observation of Children at the Worcester Normal School"; in *Ped. Sem.*, vol. 1, pp. 219-24.
9. Cattell, J. McK. "Mental Tests"; in *Mind* (1890), vol. 15, pp. 372 ff.
- *10. Claparède, Ed. *Experimental Pedagogy* (1910), pp. 38-99.
11. *Cyclopedia of Education*. Paul Monroe, editor. See "Child Psychology" and "Child-Study"; in vol. 1, pp. 611-20.
- *12. Dearborn, G. V. N. *Moto-Sensory Development*. (1910.) 215 pp.
Illustrates the individual-biographical method.
- *13. Drummond, W. B. *An Introduction to Child-Study* (1905), pp. 8-37 and 69-108.
14. Freud, S. "The Origin and Development of Psychoanalysis"; in *Lect. and Addresses on Psy. and Ped.*, Clark Univ. (1910), pp. 1-38.
- *15. Gault, R. H. "A History of the Questionnaire Method of Research in Psychology"; in *Ped. Sem.*, vol. 14, pp. 336-83.
16. Hall, G. S. "Methods, Status, and Prospects of Child-Study of To-Day"; in *Trans. of Ill. Soc. for Child-Study*, vol. 2, pp. 178-91.
17. Hall, G. S. "Unsolved Problems of Child-Study and the Methods of their Attack"; in *Proc. N.E.A.* (1904), pp. 782-87.
18. Hall, G. S. "Child-Study versus Adult Psychology in the Training of Teachers"; in *Proc. N.E.A.* (1904), pp. 568-75.
19. Hall, G. S. *Aspects of Child Life and Education* (1907), Preface, pp.

20. Jones, E. "Psychoanalysis and Education"; in *Jour. Educ. Psy.*, vol. 1, pp. 497-520.
21. King, I. *The Psychology of Child Development* (1903), pp. 1-15.
22. Kirkpatrick, E. A. "The Point of View of Genetic Psychology"; in *Jour. of Educ. Psy.*, vol. 1, pp. 76-82.
23. Lang, O. H. "Some Cautions to be Observed in Child-Study"; in *Proc. N.E.A.* (1898), pp. 898-902.
24. Monroe, W. S., Chambers, Kline, Williams, and Hall. "Methods of Child-Study"; in *Proc. N.E.A.* (1904), pp. 759-87.
25. Monroe, W. S., De Voss, and Kelly. *Educational Tests and Measurements* (1917), chaps. VIII-XI, pp. 241-302.
26. Montessori, Maria. *The Montessori Method.* (1912.) Especially chaps. I, II, and IV.
27. Morgan, C. L. *Introduction to Comparative Psychology.* (1906.) 386 pp.
28. Myers, C. S. *Text-Book on Experimental Psychology.* (1909.) 432 pp.
29. O'Shea, M. V. "The Purpose, Scope, and Methods of Child-Study"; in *Jour. of Ped.* (1898), vol. 11, pp. 9-22.
- *30. Partridge, G. E. *An Outline of Individual Study. A Manual of Methods for Beginners.* (1910.) 240 pp.
31. *Proceedings of the National Education Association.* See "Child Study."
32. Rugg, H. O. *Statistical Theory Applied to Educational Problems.* (1917.) 410 pp.
- *33. Rusk, R. R. *An Introduction to Experimental Education* (1913), pp. 2-23.
34. Russell, E. H. "Study of Children at the State Normal School, Worcester, Mass.," in *Ped. Sem.*, vol. 2, pp. 343-57.
35. Russell, E. H. *Child Observations* (1896), Introduction, pp. vii-xxxiii.
36. Scripture, E. W. "Aims and Status of Child-Study"; in *Educ. Rev.*, vol. 8, pp. 231-39.
37. Shinn, Miss M. W. *Biography of a Baby.* (1900.) 247 pp.
38. Smith, Miss T. L. "The Questionnaire Method in Genetic Psychology"; in *Ped. Sem.*, vol. 10, pp. 405-09.
- *39. Terman, L. M. *The Measurement of Intelligence.* (1916.) 362 pp.
40. Thorndike, E. L. *Educational Psychology*; vol. 1, *The Original Nature of Man* (1913), pp. 27-42.
41. Titchener, E. B. *Experimental Psychology: Student's Manual* (1905), pp. 38-106.
42. Villa, G. *Contemporary Psychology* (1909), pp. 128-72.
43. Whipple, G. M. *Manual of Mental and Physical Tests, Part I*; especially pp. 1-60. (Bibliography.)
44. Witmer, L. "Clinical Psychology"; in *Psych. Clinic*, vol. 1, pp. 1-9.

CHAPTER III

BIOLOGICAL PERSPECTIVE

“Child study marks the introduction of evolutionary thought into the field of the human soul.” G. STANLEY HALL.

Application of the principle of evolution. Since the day of Charles Darwin the theory of organic evolution has become a generally accepted working principle in all the biological sciences. In our own day the principle has been most illuminatingly applied to the study of children. For this we are chiefly indebted to G. Stanley Hall, who has brought about the realization of the fact that in both body and mind the child is a product of æons of racial inheritance, and that in neither can he be rightly understood except as a product of the past and a prophecy of the future. The scope of the present discussion makes it impossible for us to dwell upon disputed points, to present details of evidence for and against, or even to give adequate explanation of the theory of evolution and its general applicability. We shall confine ourselves to those points which serve to show the value of applying the principle to the study of child life. Facts and principles of two kinds demand attention. First, those concerning the development of the human species with pertinent facts about other species, and, second, those concerning the development of the individual human being. To use the scientific terms, we are to examine the facts and principles of phylogeny and ontogeny. The latter is to be our chief concern, but since ontogeny develops upon a phylogenetic foundation the individual cannot be understood apart from the racial. We must, therefore, briefly outline the theories and principles of racial evolution.

The theory of descent. The theory of organic evolution is an attempted explanation of the *method* of creation. Broadly speaking, it holds in the biological realm that all forms of life that have existed or that now exist have descended from one another and from a common ancestry, or from a limited number of original species. In the realm of sociology the present complex organization of society is looked upon as a gradual evolution from the simple and elemental social institutions of earlier ages. In the field of psychology the origin of mind is sought in the study of its most primitive forms. In short, the principle is merely a more specific, exact, and scientific statement of the everywhere-observed tendency to growth, development, and increasing complexity of structure, form, and function among living things and institutions. Some such theory has been repeatedly stated more or less definitely by philosophers and naturalists, and from at least as early as the beginning of Greek philosophy to our modern pre-scientific age. Instances of crude evolutionary thought are not lacking among primitive peoples.

In spite of this it remained for the nineteenth century to give the theory a scientific statement. Erasmus Darwin (1731–1804) and Lamarck (1744–1829) had made a serious attack upon this problem. To Lamarck credit is due for the first complete theory of organic evolution. His view was that by use, disuse, or injury, characters may be acquired by an individual and transmitted to his offspring. A succession of cumulative acquirements in a given direction would, he believed, give origin to new species. His theory was speculative and was not based upon scientific data, and so it was in reality a new and unsolved problem which Charles Darwin set himself, — that of placing the theory upon a scientific basis. As a result of years of painstaking and patient study he was able to give it such a basis, in the year 1859, by the presentation of a theory, with its supporting

facts, — his “selection theory,” — which was wholly new and which has made Darwin’s name the greatest in the history of biological science. No other scientific principle which has emanated from the mind of man has been more revolutionary. It has stimulated thought and research in every realm of life, and has created new and important sciences. Even the thinking of those who reject his theory has been profoundly modified.

Source of evidences. The evidences for the theory of descent come from five main sources. (1) Comparative anatomy, which yields evidence of structural homologies between organisms of different species. (2) Palæontology, which has clearly revealed similar homologies between living species and extinct ones, the fossil remains of which are to be found in various geological strata. (3) Anthropology, which deals with the similarities and dissimilarities between races of different degrees of culture and civilization, revealing definite evolutionary tendencies. (4) Comparative embryology, which supplies exceedingly interesting data concerning the progressive, evolutionary stages of individual development (ontogeny), which analogy has suggested as strikingly illustrative of an epitomized history of racial stages (recapitulation), and that are at least entirely in consonance with the theory of descent. (5) Comparative psychology, which, by comparison of the mind of the adult with that of the child, of either with the minds of animals, of the mind of higher with that of lower animals, of that of higher with that of lower races, and by the study of folk-lore, traditions, human institutions, language, and arts, furnishes the data for the theory of mental evolution.

The nature and reliability of such lines of evidence cannot be dwelt upon in detail here. There is a vast literature, and we shall have to assume some general knowledge of the subject on the part of the reader. We can only say that the

evidence has been so convincing along many of these lines that biologists are agreed that the homologies discovered in the various fields of research are best explained when considered to be evidences of blood relationship and community of ancestry. It is needless to say that there is still a lack of convincing proof of many points which will remain in dispute until such evidence can be found.

The problem of Darwin. Darwin's problem was, "How have species originated?" In quest of an answer he went to Nature herself. He observed (1) that the increase of all forms of animal life is in geometric ratio, and is therefore extremely prolific (multiplication); (2) that there is a constant appearance of differences among animals of the same species and generation (variation); (3) that there is a strong tendency to transmit such variations along with the essential similarities of form, structure, and function which characterize a species (heredity). He observed further (4) the destruction of great numbers of animals through lack of sufficient food, through conflict with enemies, through inability to resist unfavorable climatic or other changes, and the like (natural selection); (5) the fact that survival in this "struggle for existence" of individual with individual and species with species, or of either with other hard conditions, appeared usually to fall to the lot of those individuals and species that varied from their kind in ways which gave them an advantage over their contemporaries, so that they remained to produce offspring ("survival of the fittest") and thus transmit, in accordance with the laws of heredity, their advantageous variations.

From these and like facts Darwin reasoned that of the multitudes of animals born, the few that survive do so by reason of advantageous variations which give them supremacy in the struggle for existence. The offspring of these survivors vary around a new point of vantage, and among

the survivors are likely to be those who vary still further in the same advantageous direction. Thus, by a process of cumulative additions in succeeding generations of variations in certain advantageous directions, new types or species gradually arise which are better adapted to their natural environment than those from which they sprang. On the basis of such observations Darwin proposed his theory of the origin of species by a *process of natural selection* of small fluctuating variations of an advantageous character. On this theory the process of adaptation is a process of continual concession of the species to natural environment. It is the resultant of the simultaneous operation of the factors of multiplication, variation, natural selection, and inheritance.

It would have been nothing short of miraculous for any one man to discover, in so complex a field, a completely satisfactory theory. Darwinism has been widely criticized, and as an entirely correct explanation of the origin of species would be repudiated by Darwin himself were he living today, — indeed, he never claimed infallibility for it. But Darwin's idea of selection as the essential process in evolution of species has placed all his successors deeply in his debt. Darwin himself gave no satisfactory explanation of the origin of variations, which is now one of the problems upon which more light is extremely desirable. He had little to say of the details of the laws of heredity, which are now the subject of most serious study, and he offered no satisfactory explanation of the mechanism of hereditary transmission. He did set the whole scientific world seriously at work to perfect theories of racial and individual evolution, and to seek proofs for them. If he had done no more his name would deserve to be inscribed among the immortals.

Following the epoch-making work of Darwin it soon became evident that further progress in theories of evolution

lay in the direction of investigations of the causes of variation and of the mechanism of heredity. The closing years of the nineteenth century witnessed a gradual shifting of interest from the problem of the origin of species to that of the origin of the individual. The latter is the more practical problem. However the human race may have originated, our hope of improving the inborn qualities of human nature now must rest upon our understanding of the laws of variation and inheritance, and upon the possibility of control of these great evolutionary forces.

The earlier theories by which attempt was made to explain the mechanism of heredity cannot be dwelt upon in detail here.¹ The emboîtement theory of Bonnet that a fully formed animal in miniature was contained in the egg made its exit perforce with the beginning of microscopic study of embryology. Darwin's pangenesis theory, which postulates minute "gemmules" or particles of matter derived from the various somatic tissues, and which, circulating freely in the blood, come together in the germ cells, make up their constitution, and eventually develop into cells, has also been discarded. The theory had, of course, no basis in scientific fact, as had his selection theory, nor did Darwin have great faith in its accuracy. Galton, in his early books, makes considerable use of it, and as an explanation of the physical basis by means of which acquired characters may be transmitted, it is perhaps as good as any theory yet advanced. The theory of germinal localization proposed by His, which would make certain areas in the germ cell represent and develop into specific parts, organs, and tissues, has not been satisfying. The ideo-plasm theory of Nägeli, which pro-

¹ Here and throughout the remainder of this exposition the reader must be referred to such references in our bibliography as: Castle (5), Conklin (9), Jordan (40), Parmelee (44), Thompson (56), Walker (68), Walter (64), etc., for fuller details.

poses for each species its own peculiar plasm, which determines the character of germ cells and offspring, replaces definite locations with definite substances, and seems somewhat nearer the truth. There is no evidence against the theory, and some features of it are found to accord well with those of the chromosome theory which now has a large following. Discussion of the latter is involved in and will be made incidental to a brief exposition of the cell theory of modern biology.

The cell theory. Modern biology since Schleiden and Schwann (1838-39) teaches, among other things, that all living organisms, whether plant or animal, are composed of cellular units whose essential substance is protoplasm. Cells differ in form and structure as the organisms of which they are the units differ and as the functions they perform are diverse. All animal cells are, however, essentially alike in that all are constituted of a nuclear body enclosed by a cellular wall, which in turn is surrounded as a rule by cytoplasm and a second enclosing membrane. In short, every cell consists of a cell body and a nucleus, if we disregard for the present certain minuter structures. In addition to this structural similarity all animal cells have, among others, the same functional capacities of secretion, digestion, assimilation, excretion, and reproduction of kind, and this is true whether they be independent organisms or only constituent parts of complex multicellular organisms. The unit of life is the protoplasmic cell. Here lie the secrets of life.

For convenience we may roughly and somewhat arbitrarily divide all forms of animal life into (1) the unicellular and (2) the multicellular. The study of unicellular organisms has in recent years added much to our knowledge of cell life in general, since all forms have very much in common, but since our chief interest is in higher animal life, especially that of man, we shall confine our attention largely

to the higher forms. This we may the more safely do since whether, uni- or multicellular, all animal organisms begin their existence as single cells essentially similar in structure and indistinguishable in gross appearance, however much they differ in potentiality. In this fact the original kinship of all life is strongly suggested. On the other hand, the extreme simplicity of the one and the marvelous complexity of the other dimly suggest the æons it must have taken to develop the higher from the lower forms. Nature's method of differentiation of form and function in cell life, and of transmission of such differentiation, is the great problem of both racial and individual development. This is in large measure the present problem of experimental embryology. The evolutionary viewpoint has supplied new motive and incentive for the embryologist. It is our purpose to trace briefly the significant steps in individual development, or ontogeny, so far as they have been made out, in the belief that such a sketch helps us to think more clearly concerning the vexing problem of heredity.

Ontogeny. As was just said, every organism begins its life as a single cell. The single-celled amœba originates from a parent amœba like itself by a simple process of division of the nucleus and cell body of its parent into two similar cells of which it is one. It has in like manner the capacity of becoming parent, and by a similar division literally to become two individuals, for in a sense the division is such that there is nothing new here. Each of these cells can in turn repeat this process, under favorable conditions, more or less indefinitely. The process of multiplication and rejuvenation may be followed for hundreds of generations, but still the amœba produces other amœba and nothing else, and all are very much alike.

If, on the other hand, a multicellular organism be studied, we find the method of reproduction quite similar in the

initial stage, and yet by no means so simple as we shall see. In the first place, among all higher animals, sexual reproduction is the rule. Other intermediary forms which lie between mere fission and sexual reproduction we shall pass by without discussion here. In sexual reproduction a new life originates not by the division of the parent body, but by the fusion of the nuclei and cell bodies of an *ovum* and *spermatozoön* derived respectively from a female and a male organism of like species. The resultant cell, commonly known as the fertilized ovum or "parent cell," is the beginning of a new life. It is a new organism. It contains within itself the potentiality of becoming a complete organism like the parents with whom originated the germ cells whose union produced it. The way in which this potentiality becomes fact is nature's most fascinating story.

Prior to their union into the "parent cell" or new life, certain significant changes take place in the germ cells themselves which must be briefly examined. The ovum and spermatozoön, which were doubtless primitively exactly alike, and which in an early stage of their development are still indistinguishable, are in their mature state structurally quite unlike (Fig. 1) and vastly different in bulk, though each possesses all the essential qualities of all cells. In

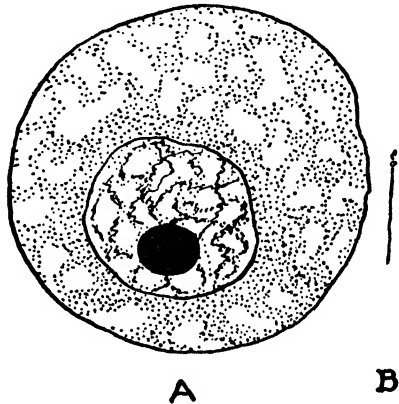

FIGURE 1. OVUM AND SPERMATOZOÖN
A, Ovum. B, Spermatozoön.

reaching the mature stage each of these cells passes through three preliminary stages, (1) a period of multiplication, (2) a period of growth, and (3) a period of maturation. These are preparatory stages of great practical and theoretical importance. Their significance lies chiefly in the fact that in the process the number of chromosomes in each is reduced to one half the number characteristic of the species. These chromosomes, which are minute V-shaped microscopic bodies found in the nucleus of the cell, are usually uniform in number for a given species, — probably twenty-four in the case of man according to Conklin, — and, as we shall see, play a very important rôle in cell division. Having passed through these three stages the germ cells are ready for the process of fertilization.

In its mature form the ovum is nearly spherical in shape and varies from .22 to .25 mm. in diameter. The larger part of its bulk is constituted of food material for the developing embryo. The cell itself is immobile. The spermatozoön is a very minute, active, mobile cell, about .05 mm. long, but in bulk containing only from one one-hundred-thousandth (Wilson) to one one-hundred-millionth (Hertwig) part of the volume of the ovum. It usually has a cylindrical or conical head containing the nucleus, a short middle-piece containing the centrosome, and a long vibratile tail of differentiated cytoplasm which serves as an organ of locomotion, enabling it to find and penetrate the cell wall of the ovum.

Fertilization. The process of fusion of the mature ovum and the spermatozoön in sexual reproduction is an exceedingly complex one. The process begins when a spermatozoön, by means of its peculiarly adapted structures, finds and penetrates the wall of a mature ovum. Immediately thereafter there begins an intricate series of transformations in the minute structures of the cells, and especially of those of the nuclei, the details of which it is not in place to present

here. The significant part of the process for our present purpose is the selective division and combination of the chromosomes of the nuclei. The result of their combination is the restoration, in the "parent cell," of the characteristic number which, as was pointed out above, were reduced by one half in the process of maturation of the germ cells. Still more significant is the fact that, in the "parent cell," the chromosomes are now constituted of a combination of exact halves of chromosomes derived respectively from each of the germ cells. The process is a highly selective one, and evidently by no means chance or meaningless.

A further result of fertilization is that this "parent cell" now possesses the potentiality, which neither germ cell alone possessed, of developing into a complete, mature organism, true to the species of its progenitors. Since it is the human germ cells of which we

are speaking, it is potentially man. In other words, it is the carrier of inheritance. In it heredity makes its full and final contribution to the individual, the potentialities of whose inheritance from that point on begin to be realized. Heredity can add no more. Even prenatal influences must all be looked upon as environmental. They affect the developing embryo, so far as heredity is concerned, no more than the favorable conditions furnished by an incubator affect

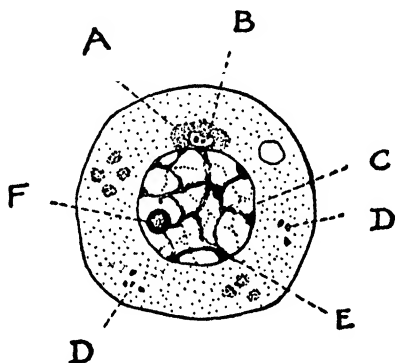
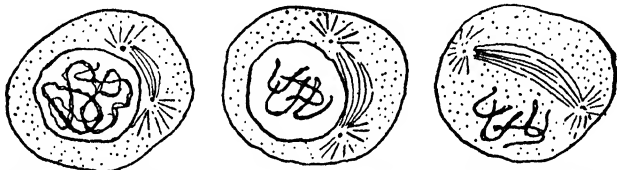

FIGURE 2. THE PARENT CELL

- | | |
|----------------------|--|
| A, archoplasm. | D, food particles. |
| B, centrosomes. | E, chromatin with connecting threads of linin. |
| C, nuclear membrane. | F, nucleolus. |

the inheritance of the chicks it hatches from the eggs of the hen.

Mitosis. The process of mitosis (cell division) is essentially the same everywhere. There is no sufficient reason for our dwelling upon all the minute details of the early stages of this process. The accompanying figures (a-i) give an idea of their nature. By the very intricate and selective



(a) Spireme. Asters formed. (b) Chromosomes. Spindle forming. (c) Nuclear membrane lost.

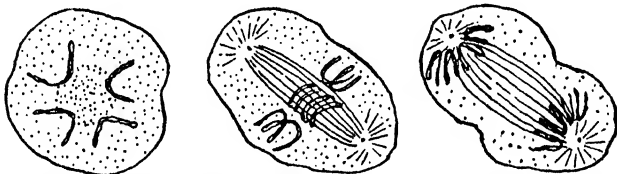

(d) Chromosomes attached to spindle fibers (polar view). (e) Chromosomes attached to spindle are splitting. (f) Longitudinal half of each chromosome grouped at opposite poles (lateral view).



(g) Division of cell body. (h) Reconstruction of nuclei. (i) Two complete daughter cells.

FIGURE 3. CELL DIVISION

process there shown the "parent cell" divides into two daughter cells. Each of the daughter cells goes through a similar process, by means of which a four-cell stage is reached. Each of these in turn divides to form a generation of eight cells, and so the process of multiplication continues in geometric ratio. In all this division and subdivision each and every cell receives the characteristic number of chromosomes, and each is constituted of material derived equally and impartially from each parent germ cell. Every cell of the complete organism has therefore a bi-parental heritage.

At first the daughter cells appear to be exactly alike in form, structure, and function. After a time, however, differentiations appear. One group of cells, the germ cells, are believed to be segregated and set apart from all the rest at an early period, to retain alone the power, under proper conditions, to give rise to an entirely new organism. Other groups are soon differentiated in form and function and set aside for the production of the various specialized parts, organs, and tissues of the body. We can take time here merely to outline the beginning of this differentiation. When by division in geometric ratio the number of cells has reached perhaps one hundred and twenty-eight, there is formed what is known as the *blastula*, which is a spherical mass of cells composed of an outer group and an inner mass grouped at one side of a large vesicle or cavity enclosed by the outer group. Soon after this stage there develop in all vertebrate embryos three primary germ layers of cells, the *ectoderm* (outer layer), the *mesoderm* (middle layer), and the *entoderm* (inner layer). The process of differentiation of parts and tissues from these primitive germ layers has not been positively made out in the development of the human embryo, and the details of it would take us too far afield. It seems clear, from inferences drawn from the study of embryos most like the human, that the development is

somewhat as follows. The entoderm, whose cells are less modified from their primitive structure than those of either of the other layers, form the basis of the digestive system and its associated glands. From the mesoderm develop among others the supporting tissues (bone and cartilage), the striated muscles, and the blood. The ectoderm gives rise to the epidermis and its derivatives, to the nervous system, and several other groups of tissues (46).

It is now generally believed that after this differentiation of cells to form various tissues has taken place, the cells retain the capacity to produce other cells of their own related groups only; as, for example, bone cells produce other bone cells, muscle cells other muscle cells, etc. The more highly differentiated in structure and function a cell is, the less capacity it appears to have to produce anything but its own kind. It is even thought that the very highly specialized cells of the cerebral cortex have lost the power to multiply further, and that the full number of such cells is fixed for life possibly before birth, or at least very soon after.

Rise of parts and organs. The processes by which parts and organs of the body are gradually built up out of the primitive germinal layers by cell division and functional differentiation, and the order in which such development takes place, constitute a long and intricate history. Aside from the study of the minute structure and activity of the cell in mitosis, the tracing of the successive stages of embryological development, and the attempt to interpret the meaning and significance of those stages, have occupied much of the time of embryologists for some years past. One of the most interesting of the discoveries of the embryologist is the fact that all animal forms pass through similar stages, and the still more significant fact that at certain stages the embryos of animals as dissimilar as reptiles, birds, and mammalia can only with difficulty be distin-

guished from one another. It has been further found that rudimentary organs arise at certain stages, continue for a time, and then either disappear or regress.

Drummond (23, pp. 44-49) and Tyler (61, pp. 49-53) give interesting brief accounts of the course of embryological development to illustrate the significant fact that during the early stages it would be quite impossible, if one could watch the whole course of development step by step, to tell what species of animal was being formed. There is little even remotely suggesting the human to be found in the form of the embryo of one month (46, pp. 94, 95). Comparative embryology shows clearly that not only can the human embryo not be distinguished at early stages from that of other higher animals, but that it is for some time equally difficult to distinguish it from other lower forms. At one stage appear characters most like those of some of the low forms of sea life; at another like those of worms. Only with the unmistakable appearance, along the centrally located groove which is to be seen soon after the embryo assumes its elongated form, of little solid masses of cells arranged in a row, can we be certain that it is the embryo of a vertebrate with which we have to do. Even then we may easily mistake it for the embryo of a fish, for along the neck are to be seen what can be nothing else than the gill slits characteristic of primitive fishes. So, too, the examination of the heart at this stage reveals an organ of two chambers instead of four. Only when several stages of the development of the embryonic lungs have passed can we be certain that we are observing an air-breathing vertebrate. Still later the little prominences which slowly assume the form of limbs can only, by considerable stretch of the imagination, be conceived of as arms and legs; still less can one with certainty identify the slight protuberances at their extremities as hands and feet. Our difficulty is increased by

the fact that at the same stage a well-marked tail, which will later disappear entirely, is seen at the end of the spinal column. But all these stages pass, and little by little each part and organ assumes more and more the typical human form. When the embryo, at about the end of the second month, has acquired unmistakably the form and structure of the human infant, it is thereafter known as a *fœtus*. The unmistakable likeness of the human foetus to the form of the newborn infant should not blind us to the equally unmistakable differences which only the last stages of embryonic life obliterate. Still more important is it that we should not allow ourselves to remain unmindful of the fact that the body of the newborn babe is quite as different from that of the mature adult as is that of the ape. From birth to maturity many significant transformations must still take place. To have made this point and its significance somewhat clearer is, indeed, one of the most noteworthy contributions of the scientific study of children.

The physical recapitulation theory. By such facts as those just outlined, as also by the fact that all animal forms originate in single cells, is strongly suggested the probable original kinship of all life. In fact, embryology has furnished and is furnishing some of the strongest evidences of the truth of the general theory of evolution. In these same facts the theory of recapitulation has found some of its strongest support. The story of individual development as we have outlined it has been assumed to be an epitome of human descent. Von Baer (1792-1876) suggested such a theory, but it was first clearly stated by Fritz Müller in 1863. According to this theory animals are believed to live over in their individual development, with some omissions and inversions of order, the various evolutionary stages through which their ancestry has passed. In Haeckel's concise phrase, "ontogeny repeats phylogeny." Physical recapitu-

lation is assumed to be almost complete at birth, but mental recapitulation is almost if not entirely post-natal. This theory that the individual repeats the general features of the whole racial life would, of course, if it could be proved to be true, have profound significance in the interpretation of many phases of child life and activity. Without waiting for convincing proofs, the theory has already been widely so used by many scientists. In the physical field Ernst Haeckel has made perhaps the most sweeping applications of it.

In the mental field it has been applied again and again by Hall and many of his earlier students, whose purpose it has been in part to find proofs of the theory in this field. This desire, coupled with the conviction that the human soul can only be known in its completeness when its whole phyletic history has been traced, has been the stimulus of very much of Hall's research. Even those who cannot follow him admit the fascination and stimulus of his genius in application of the theory. It must be said, however, that the theory rests on a very uncertain foundation, and that a recent reaction has set in against the sweeping applications of it that have long been current. Especially is this true of the pedagogical application of it by the Herbartian school, known as the theory of "culture epochs."

Prenatal influences. The relation of the embryo to the mother during the prenatal period must be briefly examined for its bearing upon theories of inheritance. It must not be forgotten that, in most lower forms, and also in some relatively high in the animal scale, absolutely nothing is done for the offspring after the production and fertilization of the egg. (Fishes, toads, and many other similar forms are cases in point.) In others, as in the case of most birds, the incubation is presided over, usually by the mother, and some care is given the young after birth, but, aside from the provision

of the necessary warmth for incubation, the development of the egg through the embryonic stages to the newly hatched chick is entirely directed from within. In higher forms, where the embryo develops *in utero*, there is a very intimate relationship with the mother during gestation. The developing embryo receives its nutriment and protection, during the period of its growth and development, from the mother. There is a strong popular conviction that both the body and the mind of the human child can be influenced for good or ill during this period. Scientific study indicates the necessity of considerable revision of the popular view. Embryologists point out that the connection between the mother and the embryo during the period of gestation is merely one by means of which the mother's blood supplies nutrition to the yolk of the embryo. Disturbances of nutrition in the mother, poisoning, infections by disease germs which may use the circulation of the blood as a means of transmission, may and do affect the embryo, but there is no other known mechanism by which it may be affected. Scientists are agreed that the whole period is one over which the mother has relatively little influence, and such as she has must be considered environmental rather than hereditary.

Healy (38, pp. 202-08) gives a good résumé of present views on the subject. He holds that it is pretty well established that "a wasting chronic disease, or a severe acute ailment" of the mother during pregnancy, may without doubt result in definite harm to the offspring. The effects of prolonged worry or emotional stress, neglect, overwork, or abuse of the mother are more difficult to evaluate, but since some of these causes are known to affect nutrition and to generate toxins, they may clearly have some effect. Recent studies made by the Children's Bureau find that infant mortality is relatively greater among children of mothers who overwork right up to the time of the birth of

their children, and yet it is difficult to prove that this fact is wholly chargeable to prenatal conditions. Alcoholism, morphinism, and epilepsy in the mother, if markedly present during pregnancy, seem also to stand convicted by positive proofs. The germ of syphilis is known to infect the embryo very frequently when present, and the effects upon both physical and mental development of the offspring are more serious than those of any other disease. Of the effects of maternal impressions (telepathic influences) we have no proofs. Biologists and physicians generally deny such influence except, as indicated above, through the possible effects on nutrition of both mother and child. In the same category stand birthmarks, popularly attributed to particular happenings. Pure chance seems a better explanation of these rare occurrences when nutritive disturbances seem inadequate. Parents who are certain of the quality of the germ plasm which they transmit to their children need have little occasion for worry over the superstitious beliefs which the popular mind conjures up, provided the health of the mother is reasonably good during pregnancy.¹

QUESTIONS AND TOPICS

1. Carefully look up in the Glossary, or in the dictionaries and encyclopedias (15), the meaning of technical terms which are new to you.
2. Just what does it mean to take the biological point of view with regard to children?
3. What advantages are there in this point of view?
4. Enumerate the sources of evidence for the theory of descent, and show the ways in which these have bearing on the problem.
5. Just what was Darwin's major problem, and how did he attack it?
6. Distinguish between Darwinism and evolution.
7. Explain the cell theory, and show its bearing on theories of inheritance.
8. State the significant facts in cell division.

¹ Mrs. Max West, *Prenatal Care*. Children's Bureau, Publication no. 4 (1913), pp. 19, 20.

9. State your own view as to the probable correctness of the theory of physical recapitulation.
10. Can the psychical states of a mother affect her unborn child? Why?

SELECTED BIBLIOGRAPHY

See Bibliography at end of Chapter IV, which covers both Chapters III and IV.

CHAPTER IV

HEREDITY

Racial and individual heritage. We have now sketched at some length a background for the discussion of heredity. If you have followed thus far, it must be clear that the heritage of every child is twofold — it is racial and individual. Body and mind are what they are in all essentials because of the operation throughout all the limitless past of the laws of life upon his ancestry. Every part, organ, function, every muscle and fiber has its history and its pedigree, which cannot be ignored if it is to be understood. On the mental side every thought, feeling, and emotion is conditioned in ways we have scarcely learned to appreciate by racial as well as by individual experience. No fact in either of these realms can be wholly ignored. Mind and body have evolved together in the race, and there are intricacies of this relationship that are of the profoundest significance.

On the other hand, each child has an individual heritage which differentiates him from every other human being. It is quite as essential to know the individual as to know the racial heritage. In the individual also mind and body develop together, here accentuating, there slurring over, everywhere in a broad way recapitulating, the racial heritage, but often combining hereditary characters in new ways. We would not minimize the part environment plays. That we shall consider in due time, but we wish to impress the fact that inheritance is fundamental. Heredity, as Conklin (9, p. 359) suggests, is the base of the triangle of life of which environment and training are the sides, but heredity in any given case is fixed in the germ plasm, while environ-

ment and training are exceedingly variable factors. The relative importance of these factors in the making of an individual is one of the most difficult, most disputed, and yet most practical problems of modern science. What has science to say of the part played by heredity?

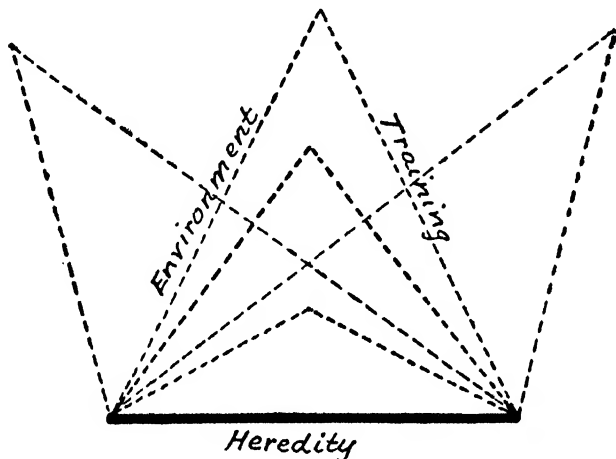

FIGURE 4. HEREDITY, ENVIRONMENT, AND TRAINING

Diagram to show the influence of heredity, environment, and training in the development of an individual. Various types of individuals (represented by the triangles) may be produced from the same germ cells (heredity) if the environment and training are variable. (From Conklin's *Heredity and Environment in the Making of Man*, by permission of Professor E. G. Conklin and the Princeton University Press.)

Definition of heredity. Castle (5) defines heredity very simply as "organic resemblance based on descent." In speaking of heredity we are dealing with the recognized tendency of all living organisms to perpetuate their own qualities and those of their race in their offspring. Offspring resembles ancestry. In line with the newest light we have on the subject, the old expression, "like begets like," is being modified to "like tends to beget like," or "like begets some-

what like," to make allowance for individual variations. The expression, the son is "a chip off the old block," needs, perhaps, to be restated, — "father and son are both chips from the same ancestral block." Heredity tends to conserve likenesses, perpetuate types, differentiate races and species. Hereditary characters are synonymous with those sometimes called "inborn," those which require for their development no other stimulus than that of nutrition, and no other opportunity than that of conditions favorable to growth. Perhaps Conklin's (9, p. 507) definition as "the appearance in offspring of characters whose differential causes are in the germ cells," is most in accord with present views of biologists.

The inevitableness of heredity. There is nothing quite so certain as the inheritance of the fundamental qualities of our ancestry. Even some of the family traits are securely stamped upon the germ plasm. From human stock nothing but human stock ever issues. The infant of the ape never grows up to be a man. An infant of pure Caucasian blood is never born to parents of pure Chinese blood. Genius does not always issue from genius, but it is certain never to arise from an unmixed feeble-minded strain. The leopard cannot change his spots nor the Ethiopian his skin. Our idealistic forefathers declared that "all men were created free and equal"; the modern biologist declares that "all men are created bound and unequal" (9, p. 448). What heredity gives, upon that must environment and training build the superstructure. /

And yet we must not take all these statements in too extremely fatalistic a sense. Heredity is not a mysterious something always to be feared, but rather a biological tendency whose laws are to be studied and understood. Heredity may be good as well as bad, and often many contributory factors are essential to the actualization of either. The

business of all who have to do with children is to help to actualize the best and repress the worst which heredity presents in every individual. This is why the physical basis of inheritance, the laws of heredity, the degrees to which and the means by which environment may affect hereditary qualities, are the most important scientific problems which engage the thought of man to-day.

THEORIES OF VARIATION AND HEREDITY

Continuity of germ plasm. The theory of continuity of germ plasm, proposed by Weismann in 1885, assumes that the germ plasm is differentiated from the somatic tissues at

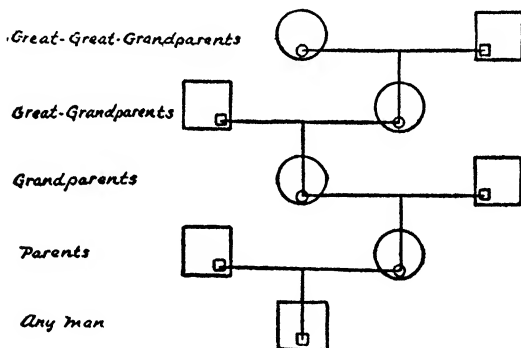

FIGURE 5. ILLUSTRATING THE CONTINUITY OF GERM PLASM

The larger squares and circles represent the somatoplasm; the smaller the germplasm in each case. Continuity from the maternal great-great-grandmother is clearly shown. The diversity of the contribution of the early generations is not indicated.

a very early stage of the embryonic period, and lives thereafter as a parasite in the body. The germ cells are in no discoverable way organically related to the somatic tissues, and are not essential to the body, although their early

extirpation does definitely affect the development of the secondary sex characters. The germ cells are, according to Weismann, merely the vehicle of transmission of life and heritage. The body serves as host and provides the conditions favorable to their multiplication and development. Inheritance is, therefore, not from parent to child, but through parent to child, except that perhaps the parent's inborn variations may directly pass to his offspring. (Inheritance is from germ plasm to germ plasm to germ plasm continuously.) To use Hall's figure, it is as though the torch of life were passed from parent to child much as a torch might be passed from hand to hand in a crowd. The hands that for a moment hold the torch in no way affect its qualities. Upon the correctness of this view rests the argument of Weismann that acquired characters are not inherited. No character he holds can be inherited which is not inherent in the germ cells. We know of no mechanism by which somatic tissues can affect the germ plasm.

Germinal selection. The laws of variation seem also to lie hidden in the germ cells. Darwin's gemmule theory furnished one possible explanation of germinal variation in the supposed effect of acquired changes in the somatic tissues upon the germ cells. But as we have just seen, this view has not been upheld. Weismann offers the theory of germinal selection. He postulates the *biophor* as the lowest biological unit of the germ cell. The biophors unite to form *determinants*, each of which is the basis of a certain somatic tissue. The determinants in turn unite to form *ids*, which develop into definite parts of the organism. He then assumes a struggle for nutriment within the germ cells themselves between these micromeric units. Those which secure more favorable conditions of nutrition have an advantage over those which find less favorable opportunity for development, and thus arise inborn variations in the resultant

organism. It is perhaps unnecessary to say that this and the numerous other meristic theories, which we have no space here to present, are purely hypothetical. They can probably neither be proved nor disproved except by the reasonableness with which they work out in practice and the degree to which they accord with known facts. Such theories offer a reasonable basis for the origin and perpetuation, from generation to generation, of germ cells, of variations in definite directions. Upon them, when they are of sufficient importance to have real life or death significance, the process of natural selection as suggested by Darwin can act. The variations here postulated, it must be noted, are due to internal factors, not to external ones. This is Weismann's chief contention./

Mendelism. Again, bi-parental inheritance gives occasion for variations to arise. No two germ cells are exactly alike in potentiality, still less those originating in different individuals. In the fusion of diverse cells there is every opportunity for the accentuating of some, the repressing of others, and the originating of distinctly new traits. The now famous monk, Johann Mendel, as early as the sixties, in his classic experiments with peas, formulated three important principles of inheritance. (1) He postulated the existence of "unit characters," which are inherited as a whole. (2) That the unit characters are of two kinds, — dominant and recessive, — which, as the terms indicate, are respectively more and less persistent in offspring. (3) That the unit characters are segregated and that, except in the first generation, which shows only the dominant trait, they tend to appear in the offspring in the ratio of three dominant to one recessive. These principles have long been used in the perpetuation of desirable traits in domestic animals and plants, and are now believed to be applicable to man as well. Goddard (32), to use a single illustration, in his recent researches finds him-

self impelled unexpectedly toward the view that feeble-mindedness is a unit character, and that it seems to be transmitted in accordance with the Mendelian principles. If further investigations confirm this view, the discovery will prove to be one of great importance as a guide to methods of eliminating undesirable and conserving desirable qualities in the human family.

Mutation. Numerous recent writers of the Mendelian school, of whom de Vries is probably the most distinguished, have proposed the theory that large, discontinuous variations occasionally occur suddenly, and that they are from the first fixed and heritable. Such variations

are called *mutations*; an individual possessing such a variation is called a *mutant*. It is believed that environmental influences may bring an organism to a state of mutability, or that the cumulative effect of such influences may suddenly show itself in a mutation. Just how the germ cells are affected by such influences is not clearly shown. Should this theory be established, it avoids some of the criticisms of Darwin's natural selection of small fluctuating variations, especially the objection that the Darwinian process is too slow to be reasonable. Unfortunately the experiments on which the de Vries theory rests have for the most part been with plants, and there is even doubt of their conclusiveness in the realm of plant life. The theory is, however, to be seriously reckoned with.

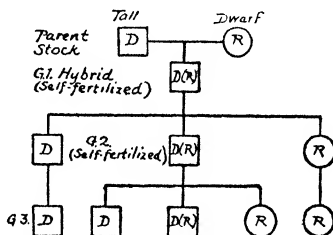

FIGURE 6. ILLUSTRATING MENDEL'S LAW

Diagram to show the distribution, through three generations of garden peas, of dominant (D) and recessive (R) traits, tallness and dwarfness respectively, in accord with Mendel's law, when inbreeding or self-fertilization occurs regularly after the initial cross.

Galton's laws. Among the earliest attempts to formulate some of the laws of inheritance by statistical studies was that of Galton. His own studies in this field led him to the statement of two such principles. The best known is his *Law of Ancestral Inheritance*, in which he stated the contribution of each ancestor as follows:

One half of inheritance comes from the two parents;

One fourth of inheritance comes from the four grandparents;

One eighth of inheritance comes from the eight great-grandparents;

One sixteenth of inheritance comes from the sixteen great-great-grandparents.

So the contribution diminishes in geometric ratio with each succeeding generation. This is, of course, a general statement of the average contribution of each ancestor, and takes no account of the prepotencies of particular ancestors. Galton admits that if a part of the heritage is due to individual peculiarities the contribution of 'ancestry is diminished by so much, but would make the law still apply to the *ancestral* contribution. On this law the contribution inherited in an unchanged form from remote ancestry is practically nil, instead of being, as the recapitulation theory would hold, the largest part of the heritage.

The other principle suggested by Galton is spoken of as *The Law of Filial Regression*. It is a statement of Nature's apparent tendency to maintain the type or average. The illustration of height is oftenest used. Parents, both of whom are unusually tall, as a rule have children who are taller than the general average, but shorter than themselves. On the other hand, if both parents are excessively short in stature, the children will be taller than the parents, but shorter than the average. He applied the principle to mental traits and capacities as well as to physical ones. The validity of both principles as originally stated has been

questioned. One of the serious criticisms is that they are based on questionable statistical material rather than on biological considerations.

Are acquired characters inherited? Conklin (9, p. 503) defines an acquired character as "a character, the differential cause of which is environmental." It is universally agreed that the characters of any adult are partly of this class, and partly hereditary. There has been interminable controversy in recent years as to whether one may transmit the results of his personal achievements as well as his inborn traits. A good part of the controversy might have been avoided by a more careful definition of terms and a more exact statement of the problem. In the first place, it is a question of *biological* inheritance that is at stake, — not social heritage upon which all are agreed. The question is, Can somatoplasm affect germ plasm? Can nurture so affect nature that its effects will reappear in succeeding generations? Can variations which are not inborn, but which have been effected during the lifetime of an individual by such influences as environment, use or disuse, disease or mutilation, be transmitted by such individual to his offspring? Lamarck and those before him believed in such inheritance; in fact, it was made by Lamarck the means of evolution. Darwin admitted it, although he differed from Lamarck as to the means of such transmission. Galton (1875) was one of the first to express serious doubt on the question. Weismann (1885) and his followers entirely deny such transmission of acquired characters as we have defined them. The controversy still goes on, and it is quite beyond our present purpose to detail all the arguments pro and con. The hope of solution lies in the many experimental studies that have been and are being made. The weight of evidence from such studies and the weight of present opinion are decidedly against the inheritance of acquired characters.

The best we know at present is that all the more stable physical traits are derived from inheritance. The number of bones, the number and arrangement of muscles, the general nature and location of the parts and organs, are determined by the nature of germ cells. Such secondary characters as color of eyes, skin, and hair, shape of head, nose, facial angle, height, proportion, and even such matters as peculiar postures and gaits and the like, which are due to deep-seated physical causes, belong also to heritage. General mental capacity, and the aptitude for particular mental accomplishments, are undoubtedly also hereditary. Mental and moral characters appear to behave as do physical ones, although the basis for their heritability is much less clear. Davenport (18) presents evidence of the inheritance of a long list of physical defects, such as deaf-mutism, heart and eye defects, polydactylism, and many others.

To the acquired characters of a given individual belong malformations of parts or organs due to disease or accident, loss of parts, exceptional strength of arm, dexterity of hand, skill of eye, artistic, linguistic, and similar attainments, as well as diseases due to pathogenic germs, such as the bacillus tuberculosis.

It is generally agreed that children and grandchildren may inherit those specific qualities of mind and body which make for high attainment in music, art, mathematics, or mechanics. It is denied that the cultivation of such capacities in high degree by the father or grandfather will make the offspring any more likely, or the entire neglect to cultivate them make them any less able, than they otherwise would have been to achieve distinction in them. Children do not learn to read and write any more readily because their ancestry has developed these attainments in high degree for many generations. Children of equal native capacity do not acquire skill in these arts any less rapidly because

their ancestry has been illiterate for generations. As Conklin (9, p. 339) puts it, "wooden legs do not run in families, but wooden heads do." The former are acquired characters, the latter are inborn ones.

Weismann's rather extreme statement of the isolation of germ plasm has undergone some revision as the result of recent experiments. It is now believed that the somatic and germ cells are together subject to certain factors that cause changes in each. It is even conceivable that conditions arising in somatic tissues from the effects of glandular secretions during states of intense emotion, — such as grief, rage, or jealousy, — those resulting from the use of alcohol and narcotics, and from such toxins as those of fatigue, may, through the blood, cause changes in the germ cells. This, however, is something quite different from what is commonly meant by an acquired character. If such effects as those just mentioned should be clearly demonstrated, we should still need proof of their transmission. Further than that, they are likely to be very general and non-specific in character, and still more certainly non-ideational. Admission of such general changes in germ cells from environmental causes does not establish the inheritance of specific acquired characters. There is no conclusive evidence that such characters are inherited; there is much evidence that they are not.

Heredity versus environment. Which is more important in the determination of the physical, mental, and moral qualities of the human being, — heredity or environment? In a sense the question is not a proper one, for both are very important. For that very reason the question will continue to be asked until we succeed in estimating, with more accuracy than we can now, the proportionate part of each. For the present one should keep an open mind on the question. All possible qualities of the individual are potential in his

inheritance, but environment and training must continue to actualize or suppress them. The best environment cannot add to hereditary potentialities nor develop capacities that do not exist. "You cannot make a silk purse out of a sow's ear." "Who by taking thought can add a cubit to his stature?" On the other hand, hereditary qualities often resist the influence of the "best" and the "worst" in environment. The two factors are so inextricably interdependent that isolation of either for the study of its relative effect is well-nigh impossible. The problem is the more difficult, too, since the heredity of no two persons, not even twins, is exactly alike. Neither is an environment ever subjectively or actually the same for any two individuals.

The heritability of acquired characters also has its bearing upon this problem. If acquired characters could be proved to be hereditary, the relative importance of environment would be decidedly enhanced. If such characters are non-heritable, the importance of heredity is much increased. Until this question has been settled, the relative importance of heredity and environment must also remain an open question. It is debatable whether we should be better or worse off if acquired characters were certainly transmissible. If the noblest and best of intentions could always be depended upon, and if an infallibility of judgment could be presupposed among the masses of men, the possibility of inheritance of acquired characters would open the door to rapid improvement of the species. Lacking these two conditions, it opens the door to rapid degeneration also. As matters stand, Weismann's theory permits the greater plasticity for future generations. It is also true that on his theory succeeding generations are more immune from the effects of vice, immorality of parents, effects of alcoholism, of bad social *milieu* and the like.

Some scientific studies of human heredity. (1) *Francis*

Galton, the illustrious cousin of Charles Darwin and the founder of the Galton Eugenics Laboratory, was the first to make serious study of human heredity. His earliest study comprised the examination of the careers of the relatives of a large number of eminent statesmen, scientists, literary men, artists, musicians, and several other classes. His aim was to discover whether there were among the relatives of these persons a larger relative number of persons of eminence than among average men. In spite of several valid criticisms of his method, — a résumé of them is given by Sandiford (52, p. 21), — his conclusions, which have been widely quoted, are deserving of serious consideration. He found the proportion of eminent persons among the relatives of his chosen group far greater than among those of average men. Later studies of his show that parents of exceptional ability produce children of similar ability much oftener than do parents of ordinary ability. Galton (29) expresses himself as most unqualifiedly opposed to the doctrine that all are created equal (p. 14). With respect to literary and artistic eminence he concludes that men with high native ability easily rise above obstacles, while all the social advantages possible do not enable the poorly endowed to attain eminence (p. 43). "I feel convinced," he says again, "that no man can achieve a very high reputation without being gifted with very high abilities" (p. 49). Those who argue that environment has more to do with the making of men than heredity find little help from Galton's studies. His reputation as an eminent and fair-minded scientist gives weight to his conviction that heredity is much the stronger factor.

(2) *Woods's study of royal families.* Woods (67) made an exhaustive study of inheritance among eight hundred and thirty-two members representative of all the important royal families of Europe. His investigation involved esti-

mates of mental and moral qualities, as well as physical ones. His family histories show numerous instances of striking persistence of certain physical traits, numerous cases of alternative inheritance, some of persistence of mental defect through several generations, others of superior ability, and still others of mediocrity apparently illustrative of Mendelian principles. A few royal families have degenerated, but others have steadily improved. One factor in such improvement is no doubt the intermarriage of the royal families with strong, virile personalities who made their way to distinction through native capacity. Among the eight hundred and thirty-two persons are twenty-five world geniuses, which, as Hall (37, vol. 1, p. 438) suggests, "perhaps no other eight hundred random names of a class would yield." Woods does not find that luxury, consanguineous marriages, primogeniture, exalted position, nor, on the other hand, political turmoil or adverse conditions, have as a rule proved unfavorable to the inheritance of ability. If they have been unfavorable, it is in the moral rather than in the physical or mental realm. Even here he finds that "there is a very distinct correlation in royalty between mental and moral qualities" (67, p. 263).

His conclusions are much like those of Galton. "The upshot of it all is, that as regards intellectual life, environment is a totally inadequate explanation." On the other hand, "heredity not only explains all (or at least ninety per cent) of the intellectual side of character in practically every instance, but does so best when questions of environment are left out of the discussion" (p. 286). As to moral qualities, "the results obtained speak no less clearly and unequivocally for heredity as the major cause" although, he adds, "we must admit that thus far we cannot separate heredity from environment in the formation of moral qualities" (p. 287). In another connection he comes out still

more strongly in the expression of his conviction that heredity is "almost the entire cause for the mental achievements of these men and women, and that environment of free will must consequently play very minor rôles" (p. 283).

One other group of inferences of Woods's are of eugenic import. They are those based on Galton's law of ancestral heredity. The probabilities are that "quality possessed by entire ancestry is almost sure to appear. Quality possessed by one parent and half the ancestry is likely to appear, with almost equal force, in one out of every two descendants. Quality possessed by one parent only, and not present in the ancestry, has one chance in about four for its appearance in progeny. Quality not possessed by either parent, but present in all the grandparents and most of the remaining ancestry, would also have about one chance in two for its appearance in one of the children. If only one of the grandparents possessed the quality in question, then the chances of its appearance in any one of the grandchildren of this ancestor would be about one chance in sixteen" (p. 298).

(3) *Thorndike's study of twins.* Thorndike's measurements of fifty pairs of twins in the schools of New York City, by means of certain objective tests, led to the conclusion that the physical and mental resemblances between them were always greater than those between other children of the same family, and the differences between them and non-fraternal pairs of "the same age, locality, and educational system, are due, to at least nine tenths of their amount, to original nature" (60).

(4) *Cattell's study of scientific men.* Cattell (7), after a method somewhat similar to Galton's, but less subject to criticism because of more careful control of sources of error, made a valuable study of one thousand American men of science to obtain some idea of the factors which contributed to their eminence. His conclusions are that "the main

factors in producing scientific ability seem to be density of population, wealth, opportunity, institutions, and social traditions and ideals. All these may be ultimately due to race, but, given the existing race, the scientific productivity of the nation can be increased in quantity, though not in quality, almost to the extent we wish to increase it." It will be seen that he makes environmental factors much more significant than those from whom we have been quoting. He admits, however, that some of his data suggest that for high *quality* of performance men of science are born such.

(5) *Healy's study of juveniles*. Healy (38, p. 781), from an extended and careful study of one thousand juvenile recidivists, finds "no reason for maintaining any general notion that there is a class properly designated born criminals." This is contrary to the view of Lombroso and the Italian school of criminologists, who many years ago announced the discovery of a "criminal type." Goddard (32), Davenport (18), and others seem to have established, by a statistical and personal study of family histories to the number of several hundred, that feeble-mindedness is due to heredity primarily in perhaps sixty-five per cent of the cases. We shall have more to say of the relation of heredity to crime in a later chapter.

(6) *The Edwards-Tuttle family*. Another important group of studies illustrate the way in which the characteristic traits of a single individual may leave their stamp upon hundreds of individuals in successive generations and play an exceedingly important rôle in the history of the nation. On the one hand, the famous Edwards-Tuttle family (66) of Connecticut, of whose descendants 1394 were identified in 1900, has made a contribution of inestimable value to the country. The members of this family have again and again occupied positions of prominence and trust of almost every sort from President of the United States to managers of

great industrial enterprises. No member of the family is known to have been convicted of crime. Similarly the Lee family of Virginia has made a notable contribution, among many others especially of leading statesmen and military men. The Preston family of Kentucky has furnished governors, senators, congressmen, college presidents, eminent divines, and many other persons whose service to the country has been notable.

(7) *The Jukes*. In contrast with these the famous "Jukes" (24) family of New York, of which "Max" was the founder, is illustrative of the opposite extreme. To the characteristics of the wife of one of the sons of "Max Jukes," known in the literature as "Margaret, the mother of criminals," is perhaps due the unending contribution of crime, pauperism, disease, viciousness, and immorality which is about the sole contribution of the family to the country. Of 540 individuals whose histories were known in 1877, 310 had spent on the aggregate 2300 years in almshouses, 440 were physical wrecks, 130 were convicted criminals, and over half the women were prostitutes. None had ever held office or served the country in a patriotic way, and up to that year the family had cost the State more than a million and a quarter dollars. The "Ishmaelites" of Indiana, a family of natural paupers and petty thieves, present only a slightly less striking example of what a bad heritage uncontrolled may leave in its wake. The Eugenics Laboratory at Cold Springs Harbor, Long Island, has recently published several similar family histories, and is preparing others.

(8) *The Kallikak families*. Perhaps the most striking and interesting "experiment in human breeding" is that of the "Kallikak" families, whose record Goddard has recently published (31). In this record we have a single paternal head of two families; one, the 496 descendants of "Martin

Kallikak" and his wife, both of good ancestry; the other, the 480 descendants of the same father and a feeble-minded girl. All of the former were of normal mentality except two, and these were not feeble-minded. Of the latter, 143 were distinctly feeble-minded, many others were less than mediocre, and none were of exceptional ability. In conclusion Goddard (31), says, "the fact that the descendants of both the normal and the feeble-minded mother have been traced and studied in every conceivable environment, and that the respective strains have always been true to type, tends to confirm the belief that heredity has been the determining factor in the formation of their respective characters."

From these very brief statements of conclusions of typical researches it must be evident that we have here a commendable point of attack upon the intricate problem of human heredity, which supplements the bio-chemical and physical studies which we earlier reviewed. Such conflicting views as we have presented are to be harmonized, if at all, by such studies. In some respects it seems clear already that our efforts at education, social service, and moral reform have until recently entirely too much neglected the hereditary factor. The issue of such researches as those from which we have quoted, and of many others that are being, and that will be, made, should be a much more intelligent handling of children in schools, institutions, juvenile courts, and in their homes. The social problems of crime, inefficiency, drunkenness, feeble-mindedness, pauperism, and many others will find more effective remedy when the relation of inheritance to them is better understood and more seriously taken into consideration.

Social heredity. Biological or organic heredity must not be confused with social heredity, as is often done. Children are born *with* a biological heritage; they are born *into* a social one. The biological heritage is passed from parent to

child through the germ plasm; social heritage is acquired anew by each generation. Biological heredity is basal; social heritage is extraneous and more or less artificial. Social heritage is grafted upon what biological heredity gives. If the doctrine that acquired characters are not inherited is accepted, the necessity of social control of parentage, as proposed by eugenics, becomes a matter of most vital concern as the only possible means of progressive race improvement. Social heredity, however, is a partial offset to the defects of biological heritage, thanks to the plasticity of the human organism.

The vast, highly organized, exceedingly complex, and rapidly increasing social heritage of manners, customs, traditions, institutions, skill, technique, moral codes, and ethical ideals impresses itself early and late upon the growing child, so that he becomes "the heir to all the ages" as he falls heir to the material possessions of his parents. If, then, one may not transmit through physical heredity the results of his own accomplishments and those of the race, he may, nevertheless, surround his children from the beginning of their lives with all the influences which have by experience been found helpful in passing on the social heritage. Our social heritage of knowledge of the laws of health, and of the acquired skill and insight of generations of physicians, may measurably repair some of the defects of physical inheritance. The right sort of social heritage may minimize the tremendous handicap of the feeble-minded, though it cannot make him less a menace to the race. Muscular and technical skill are no longer attained by chance or trial-and-error methods. We have a rich social heritage of means and methods for their speedy attainment. Children inherit physical and mental capacities; social heredity determines the use to which they shall be put. Children are born with innate tendencies to moral and religious

responses, but their moral codes and their religious beliefs and practices are almost wholly a social heritage. The sum total of what we call civilization — that is the social heritage. Its greatest vehicle is that most distinctive human capacity — speech. Of it we shall have more to say in a later chapter. Education and training are nothing but means of rapidly inducting children into their social heritage. We proceed on the assumption that the possession of the most superior endowment is no guarantee that the best results of social inheritance will be attained unaided. We develop educational agencies. It would be well also to remember that the highest social heritage cannot be superimposed upon the lowest biological inheritance. We should more carefully adapt our educational institutions to the capacities of the learners, bearing in mind that “men are born bound and unequal.”

QUESTIONS AND TOPICS

1. What is heredity?
2. What is the physical basis of heredity, and how is it determined?
3. What is meant by the continuity of germ plasm?
4. What is meant by saying that heredity is fundamental?
5. If Mendel's law holds for the human family, what practical bearing can the fact have? Illustrate.
6. Give illustrations of the application of Galton's laws other than those of the text.
7. What difference does it make whether acquired characters are inherited or not?
8. Distinguish between traits that are heritable and those that are not. Illustrate.
9. Make the most careful distinction you can between the part played by heredity and environment respectively in the making of an individual.
10. What are the chief results attained so far in the study of human heredity?
11. Distinguish clearly between biological and social heredity.
12. Can social heredity make good the defects of biological inheritance?
13. Make the fullest possible investigation and record of your own family

history. Does it explain any of your own traits and capacities? Blanks for such record can be had from the Eugenics Laboratory, Cold Springs Harbor, Long Island, New York.

SELECTED BIBLIOGRAPHY

1. American Academy of Political and Social Science. *Race Improvement in the United States*. (1909.) 171 pp.
2. Baldwin, J. M. *Mental Development: Methods and Processes* (1906), pp. 1-35.
3. Baldwin, J. M. *Development and Evolution* (1902), pp. 1-49.
4. Boas, F. *The Mind of Primitive Man*. (1911.) 294 pp.
- *5. Castle, W. E. *Heredity in Relation to Evolution and Animal Breeding*, (1911.) 184 pp.
6. Castle, W. E., and others. *Heredity and Eugenics*. (1912.) 315 pp.
7. Cattell, J. McK. "A Statistical Study of American Men of Science"; in *Science*, vol. 16 (1906), pp. 732 ff.
8. Chamberlain, A. F. *The Child: A Study in the Evolution of Man*. (1900.) Especially pp. 1-50; 213-54.
- *9. Conklin, E. G. *Heredity and Environment in the Making of Men*, (1915.) 533 pp.
10. Conn, H. W. *The Method of Evolution* (1900), pp. 157-219.
11. Conn, H. W. *Evolution of To-day*. (1904.) Especially pp. 1-21; 288-328.
12. Conn, H. W. *Social Heredity and Social Evolution*. (1914.) 348 pp.
13. Cope, E. D. *The Primary Factors of Organic Evolution* (1904), pp. 398-472.
- *14. Crampton, H. E. *The Doctrine of Evolution*. (1911.) 311 pp.
15. *Cyclopedia of Education*. Paul Monroe, editor. Vol. 5, p. 866; "Mind and Body"; p. 867, "Nervous System"; and p. 873, "Organic Evolution."
- *16. Darwin, C. *Origin of Species*. (1859.) 458 pp.
17. Darwin, C. *Descent of Man*. (1871.) 588 pp.
18. Davenport, C. B. *Heredity in Relation to Eugenics*. (1911.) 298 pp.
19. Davenport, E. *Principles of Breeding*. (1907.) 727 pp.
20. De Vries, H. *Species and Varieties*. (1904.) 847 pp.
21. De Vries, H. *The Mutation Theory*. (1909.) 2 vols. 582 pp. and 683 pp.
22. Drummond, H. *The Ascent of Man*. (1894.) 349 pp.
23. Drummond, W. B. *An Introduction to Child Study* (1905), pp. 38-68.
24. Dugdale, R. L. *The Jukes*. (1902.) 120 pp.
25. Ellis, H. "A Study of British Genius"; in *Pop. Sci. Mo.*, vol. 58 (1904), pp. 5-95.
26. Ellis, H. *The Task of Social Hygiene*. (1914.) 414 pp.

27. Ellis, H. *The Problem of Race Regeneration*. (1911.) 67 pp.
28. Galton, F. *Inquiries into Human Faculty and its Development*. (1883.) 387 pp.
29. Galton, F. *Hereditary Genius*. (1884.) 390 pp.
30. Gesell, A. L., and Gesell, Mrs. B. C. *The Normal Child and Primary Education* (1911), pp. 29-60.
- *31. Goddard, H. H. *The Kallikak Family*. (1912.) 121 pp.
32. Goddard, H. H. *Feeble-mindedness: Its Causes and Consequences*. (1914.) 599 pp.
33. Griggs, L. "The Inheritance of Acquired Characteristics"; in *Pop. Sci. Mo.*, vol. 82 (1913), pp. 46-52.
34. Guillet, C. "Recapitulation and Education"; in *Ped. Sem.*, vol. 7, pp. 397-445.
35. Haeckel, E. *Evolution of Man* (1905), vol. 1, plates pp. 258-364.
36. Hall, G. S. *Adolescence* (1904), vol. 2, pp. 40-94.
37. Hall, G. S. *Educational Problems*. (1911.) 2 vols., 710 pp. and 714 pp.
38. Healy, W. *The Individual Delinquent*. (1915.) 830 pp.
39. Jewett, F. J. *The Next Generation*. (1914.) 235 pp.
- *40. Jordan, D. S. *Footnotes to Evolution*. (1898.) Especially chapters 5, 6, 10 and 11.
41. King, I. *The Psychology of Child Development* (1903), pp. 156-64.
Discusses the culture epoch theory.
42. Loey, W. A. *Biology and its Makers*. (1908.) 469 pp.
43. Loeb, J. *Comparative Physiology of the Brain and Comparative Psychology*. (1900.) Chap. 14, "The Central Nervous System and Heredity," pp. 201-12.
- *44. Parmelee, M. *The Science of Human Behavior*. (1913.) Especially pp. 7-75. (Bibliography.)
45. Partridge, G. E. *Genetic Philosophy of Education* (1912), pp. 14-31. (Bibliographies, pp. 19 and 31. Epitome of Hall's writings.)
46. Prentiss, C. W. *Textbook of Embryology*. (1915.) 400 pp.
47. Punnett, R. C. *Mendelism*. (1911.) 192 pp.
48. Pyle, W. H. *The Outlines of Educational Psychology* (1912), pp. 24-33.
49. Richards, Mrs. E. H. *Euthenics*. (1910.) 162 pp.
50. Romanes, G. J. *An Examination of Weismannism*. (1899.) 215 pp.
51. Saleeby, C. W. *Parenthood and Race Culture* (1909), pp. 112-36. (Annotated bibliography.)
52. Sandiford, P. *The Mental and Physical Life of School Children* (1913), pp. 1-25. (Bibliography.)
53. Schmucker, S. C. *The Meaning of Evolution*. (1913.) 298 pp.
54. Stratton, G. M. *Experimental Psychology and Culture* (1903), pp. 262-94.
55. Seward, A. C., Editor. *Darwin and Modern Science*. (1909.) 595 pp.
- *56. Thompson, J. A. *Heredity*. (1907.) 605 pp. (Exhaustive bibliography.)

57. Thompson, J. A. *Darwinism and Human Life* (1910), pp. 129-77.
- *58. Thompson, J. A., and Geddes, P. *Evolution*. (1911.) 256 pp. (Annotated bibliography.)
59. Thorndike, E. L. *Educational Psychology*. Vol. 1. *The Original Nature of Man*. (1913.) 327 pp.
60. Thorndike, E. L. "Measurement of Twins"; in *Col. Univ. Cont. to Phil. and Psych.*, vol. 13, no. 3. 64 pp.
61. Tyler, J. M. *Growth and Education* (1907), pp. 25-62. (Bibliography.)
- *62. Tyler, J. M. *Man in the Light of Evolution* (1908), pp. 223-27.
- *63. Walker, C. E. *Hereditary Characters and their Modes of Transmission*. (1910.) 239 pp.
- *64. Walter, H. E. *Genetics*. (1913.) 272 pp.
65. Weismann, A. *The Germ-Plasm*. (1893.) 468 pp.
66. Winship, A. E. *Jukes-Edwards: A Study of Education and Heredity*. (1900.) 88 pp.
67. Woods, F. A. *Mental and Moral Heredity in Royalty*. (1906.) 312 pp.

CHAPTER V

NON-LEARNED HUMAN BEHAVIOR

The problems of human behavior. The sum total of all responses made by an organism to the stimuli from its environment has come recently to be spoken of by comparative biologists and psychologists as its *behavior*. The term is inclusive of mental as well as physical and physiological activities. In this there is the advantage of an implied recognition of the fact of the unity of all life processes, for whatever the ultimate decision may be as to the kind of relationship existing between mind and body, the fact of a relationship is not to be denied. Life is one, and is to be understood only when studied as a biological unity. Approaching the study of behavior from the biological point of view it is necessary to consider such problems as its chemo-physical basis, its anatomical and physiological correlates, its nature, its genesis, the types into which it falls, and their relationships and functions. In this chapter we undertake a very brief consideration of these problems.

The chemo-physical basis of behavior. All organic life responds to external influences acting upon it. Even the amoeba has been observed by Jennings and others to go through quite a complex series of related movements in response to stimuli of certain kinds. Such responses in the lowest forms of animal life have their basis in the intrinsic mobility and plasticity of organic matter itself. We cannot here discuss in detail the chemical and physical properties which explain the irritability of organic matter, but must assume them as the basis of all behavior as well as the basis of organic evolution. Without these qualities matter remains inert and lifeless.

Genetically speaking, the simplest form of behavior is a gross chemo-physical response of an organism to some sort of stimulus. This is the protean forerunner of all behavior. Biologists have given it the name *tropism*, a term derived from a Greek word meaning "to turn." The term is most properly used to name those purely mechanical responses of simple plant and animal forms by means of which an organism, stimulated from without, orientates itself with relation to the stimulus by either moving toward or away from the source of stimulation. Such responses are not dependent upon the existence of any specialized structures for their execution, still less upon the presence of any nervous elements. The intrinsic irritability of the matter composing the entire organism is apparently their sole basis. Extensive experimentation among biologists has pretty definitely determined the external forces which cause such responses. Davenport, as quoted by Parmelee (34, p. 85), says, "these may be grouped into eight categories, determined largely by convenience: namely, (1) chemical substances; (2) water; (3) density of medium; (4) molar agents; (5) gravity; (6) electricity; (7) light; and (8) heat." Thus, depending upon the nature of the exciting cause, we have *chemo-tropism* — orientation with respect to chemical stimulation; *heliotropism* — orientation with respect to the light of the sun; *geotropism* — orientation with respect to the earth; *thermotropism* — reaction to differences in heat intensity, etc. Speaking in evolutionary terms it may be said that the primitive sensitivity and irritability of organic matter shown in responses to such stimuli as these form the basis of all behavior.

The structural basis of behavior. The necessity of responding to such varied influences as those just mentioned made advantageous the development of specialized structures for this purpose. So it seems probable that changes in

both structure and behavior have gone on hand in hand with the course of biological evolution. A study of existing animal forms indicates that the organic processes such as metabolism, respiration, circulation, secretion, excretion, and reproduction, together with the specialized structures for carrying them out, were among the first to evolve. How this evolution took place we need not here consider, since the theories concerning it have been considered in the preceding chapter. It is sufficient to say that single-celled organisms, by multiplication and accretion of cells differentiated in structure and specialized in function, have evolved into multicellular organisms. Organless organisms capable only of tropic responses of a chemo-physical sort have been succeeded by animals with specialized organs, structures, and parts, which make much more refined and specialized responses possible. Efficiency and economy of response have been secured by distribution of functions to organs and structures so specialized as to receive and act upon stimuli of only one sort while still maintaining relationship with all other parts.

Among the differentiations of structure and function the most significant, especially in relation to higher types of behavior, is the nervous system, with the *neuron* as its elemental unit. Apart from the vital processes which still are, even in the highest forms, somewhat independent of the nervous system, the behavior of higher organisms, and especially that of man, has come to be very definitely conditioned by this master structure. Even the vital processes are integrated together, unified and coördinated by the nervous system. For example, circulation, while a function of the heart, arteries, veins, and capillaries, — structures differentiated and adapted to this definite end, — is, through the activity of the nervous system, very definitely affected by other conditions in the organism. The same is

true of the other vital processes to such an extent that changes in their functioning become definite indications of conditions in the organism as a whole. In the nervous structures we find the key to the higher action system. These structures are of three related groups, with three distinct functions. There are end organs for the reception of external stimuli, and afferent fibers to carry them inward — the receiving mechanism; there are central cells and association fibers for the interrelating of sensory stimuli, and for the excitation of motor neurons — the central mechanism; and there are efferent fibers and terminal motor neurons or axones in the muscles for the transmission of impulses from the central nervous system to the muscles, which are the specialized organs concerned with visible behavior.

With all animals that have nervous systems an external stimulus tends to involve all three of these elements, as well as the muscles, although the extent to which the nervous system is involved varies widely with different types of response. The vital processes are also affected in instinctive responses especially. The extent to which and the way in which physiological and neural processes are involved are among the most important means of differentiation of the types of behavior. With these very general statements regarding the bases of behavior, let us turn to illustration and classification of its various types as found in man.

The classes of human behavior. It is a matter of common observation that some responses are well made without training; others are poorly made after a long period of training. The infant breathes, digests his food, and his veins pulsate as the blood courses through them, driven by the rhythmic beating of his heart, as soon as he is born, and he neither wills it so nor can he will it otherwise. He takes his food from the beginning without learning how, his hands open and shut, his limbs move, his eyes close in the presence

of a bright light almost as soon as he is born, and yet he knows not why nor how. Later, after a slow and difficult series of efforts, not even begun for months, he learns to speak and to walk. He responds characteristically in specific and predetermined ways to some situations with the fear reactions; to others with those of anger. Still later he learns to restrain and to modify some of these tendencies, and to initiate others quite at variance from his original tendencies. His responses are quite diversified and of varying complexity and yet all have something in common and all together constitute what we term in general his behavior. In the interest of clearness, however, it is necessary to differentiate among these varied responses certain classes, and to define them as clearly as possible.

In general the behavior of human beings is of two main types, the non-learned and the learned; but within the first class it is customary to speak of the organic reflexes (automatic acts), the reflexes proper, and the instincts; within the latter, of habits and voluntary acts. In this chapter we are to be concerned wholly with the non-learned types, and especially with the instincts. Let us examine the responses of these types a little more closely, and give specific illustrations of each.

First, we have such processes as those of respiration, circulation, digestion, secretion, and excretion, which once set in operation continue uninterruptedly throughout life, and largely independent, except for minor fluctuations, of any influences other than those which make for healthful conditions of the organism as a whole. These organic processes, which not only do not have to be learned, but which are from the beginning practically serviceable and relatively perfect, care for the vital needs of the organism and are best termed the *organic reflexes* (sometimes spoken of as automatic acts). Most of the activities of this class are rhythmic

cal, have their stimuli within the organism itself, and make for the healthful activity of the entire organism. Second, we have such acts as sneezing, winking, coughing, the knee jerk, the adjustment of the ciliary muscle of the eye, and other simple responses of parts of the organism to simple stimuli external to the organism. These, too, are non-learned responses which are practically serviceable from the first and uniform throughout life, and are commonly called *reflexes*. Third, such complex activities as crying, recoiling from injury or threatened injury, fighting, feeding, curiosity, and the like, are quite as characteristically performed without learning as those of the two preceding types, and yet differ from them sufficiently in structural basis, in the nature of their stimuli, and in complexity to deserve to be differentiated from their prototypes. It is customary to speak of them as *instincts*, or *instinctive acts*. Fourth, there are other much more complex acts and processes, such as walking, talking, acquisitiveness, play, self-abasement, constructiveness, destructiveness, and many others, which are not so easily placed and yet are unquestionably in large part non-learned tendencies. Many of them are complexes of several instincts operating simultaneously, or of instincts and habits, so that it seems desirable to speak of those which do not properly fall into the preceding classes as *activities with an instinctive basis*.

It is well to admit that there is no hard-and-fast line of demarcation between reflexes and instincts, and that among the acts or processes properly classed as one or the other there are such close resemblances as to make our concept of either class difficult to perfect. It is the existence of genetic relationships between them that has made all attempts at definition more or less unsatisfactory. We believe that much time and effort have been spent in quibbling over definition and differentiation of the different types of

non-learned behavior that might better have been spent in careful study of the responses themselves and their place and function in human life. In spite of this conviction, since a part of our knowledge of human behavior is to be gained through reading and since language is the tool of our thinking, we must throughout our discussion hold to as definite and uniform a connotation for these terms as possible. The chief difficulty that confronts us is the extremely loose usage of the terms *instinct* and *instinctive* in the literature. We shall use these terms in a much more restricted sense than most of the writers whose works are listed in our bibliographies, so that it will be necessary for us to define somewhat more closely our concepts of them.

Upon the nature of reflexes there is little disagreement. They are relatively simple, direct, practically uniform, and non-voluntary responses of the sensory-motor type. They result from a simple external stimulation of an inborn nervous reaction arc. They do not involve the higher cerebral centers for their performance, and therefore need not arouse consciousness even after they have been executed. Their function is simple, restricted, and immediate. With instincts the case is not so simple, and further analysis is needed.

The nature of instinct. In a very general way it may be said that an instinct is: (1) an inborn tendency, with its basis in the neuro-muscular system; (2) that it involves some form of activity; (3) that connected with it there is usually some emotion; and (4) that the response is essentially uniform and usually typical for all members of a species. Upon these characteristics of instinct there is pretty general agreement. When one goes much beyond this simple statement there begins to be much difference of opinion.

Biologists, with their interest in the dynamics of living matter and the causes and genesis of behavior, stress the movement aspect of instincts and tend to differentiate them

from other types of response in neuro-muscular terms chiefly. Psychologists, on the other hand, with natural bias toward interest in the mental elements in any activity, tend to emphasize in their definitions the emotional and ideational processes involved. There is also strong tendency to emphasize their purposeful character. As a result of this difference we have definitions, on the one hand, which tend to restrict the term instinct to a very few responses, and on the other those which admit an almost unlimited number. It seems wise to avoid either extreme, and there is now a strong tendency toward acceptance of middle ground in this matter. For extreme views one may compare the list of instincts admitted by Loeb on the one hand and James on the other.

We shall make no attempt to formulate an original definition of instinct, but shall leave the matter after quoting two of the best recent ones. Instinct, says McDougall (27, p. 29), is "an inherited or innate psycho-physical disposition which determines its possessor to perceive, and pay attention to, objects of a certain class, to experience an emotional excitement of a particular quality upon perceiving such an object, and to act in regard to it in a particular manner, or, at least, to experience an impulse to such action." McDougall insists upon a cognitive, an affective, and a conative aspect in every instinct, and it will be noted that his definition is rather "heavily weighted with psychological implications." Parmelee, whose criticism the quoted words indicate, presents a biological definition which he holds is accurate and sufficiently detailed to distinguish instincts from other types of behavior, in the following words: "An instinct is an inherited combination of reflexes which have been integrated by the central nervous system so as to cause an external activity of the organism which usually characterizes a whole species and is usually adaptive" (34, p. 226). In many ways his definition is an excellent one. The reader who will

follow the defense made for his definition by either of these writers can hardly fail to get a good working knowledge of the term instinct in its best present connotation.

The stimuli which arouse instincts. McDougall's (27, pp. 31 ff.) analysis of the types of stimuli which evoke instinctive responses throws further light on the nature of these inborn tendencies, as well as upon their origin. First, there are many specific excitants of instincts varying characteristically with the species. Hall's (16) study of fears revealed many specific causes in early infancy, such as large animals, big teeth or eyes, contact with fur, etc. The young kitten given a ball or other small object runs after it and pounces upon it in characteristic cat fashion. Rabbits run from dogs or hide under available cover, true to the tendencies of their ancestry; cats stand and give battle, or climb a tree; the horse if cornered defends himself by kicking; each responds to the same situation — attacking dog — in suitable and characteristic fashion.

Second, certain non-specific situations tend always to provoke some sort of instinctive reaction. Notable among them are darkness and obscurity, novelty or strangeness, intensity of stimuli (bright lights or colors, loud noises, or, on the other hand, faint lights, sounds, colors, or tactile stimuli), objects in the periphery of vision, suddenness of appearance and movement.

Third, there is a large group of secondary situations which arouse instincts through their similarity to primary ones. These are not lacking with higher animals in general, but are peculiarly characteristic of man. They arise out of experience and complications of ideational with sensory elements. The horse jumps each time he passes the point in the road where once a dog startled him. Many wild animals fear a man with a gun that pay little attention to one without. Hall (15, vol. 2, p. 370) calls attention to the

decrease in fear of large animals, and the increase of fear of bugs, spiders, and all small creepy things in general at adolescence. Physical fears also decrease and social ones increase at this time. Fear of disease, of bombs, of live wires, of automobiles, and of offenses against social conventions come to have characteristic instinctive responses totally lacking before experience and ideation call them forth.

Fourth, there are all sorts of complications of instinctive responses due to the overlapping and blending of two or more conflicting tendencies operating at the same time. Thus arise our complex emotions, such as anxiety, jealousy, reproach, and the like. A good illustration is that of the anxious mother whose small son has disobeyed her injunction not to leave the yard and who is now nowhere to be found. Here fear, love, displeasure — the whole group of emotions centering in the maternal instinct — complicate the response and leave both it and the dominant emotion much in doubt, or cause a rapid alternation of responses and their characteristic emotions.

All these tendencies reveal the inborn nature of the action systems involved, but the later ones show, especially with man, an increasing mental element in instinctive responses and a strong tendency to radical changes both in the objects naturally exciting instincts and in the nature of the responses themselves. The relation of this fact to habit formation and to the evolution of various types of intelligent behavior will be further developed in several of our later discussions.

Characteristics of human instincts. Instincts are inborn tendencies, and yet with all higher animals, and especially with man, many of them are not present at birth. The newborn infant has just those instincts which are necessary, and those which the psycho-physical organism he possesses at the time makes possible. These are chiefly those which are self-preservative in function and those which make for

development. Among the best examples are the instinctive cries by means of which the needs of the child are made known to his mother, the already well-coördinated muscular reactions by means of which he is able to take his food, and the general tendency to make movements which furnish the raw material of later habits and voluntary acts. As growth continues, as developments due to the activity of the few instincts present at first take place, as appropriate stimuli are met with, other instincts arise.

The recapitulation theory holds that the order of acquirement in the individual is that in which they were acquired by the race. This view in its extreme form cannot be longer held. There are too many omissions and too many inversions of what must have been the phyletic order. The theory neglects to take account of such facts as that the infant is physically and physiologically incapable of some of the instinctive responses that must have been acquired very early by the race. In spite of its defects, this theory has been exceedingly suggestive and has been the stimulus of many researches, to which in large measure we owe the discovery of the fact that the order of rise and development of innate tendencies is fairly definite and uniform for different members of the race.

Whatever the cause may be, each instinct has its nascent period at a time when need, physical and physiological condition, and appropriate stimulation combine to call it forth. Nature has her own time. For a few instincts, such as that of sex, this time does not come until physical and physiological maturity are entering their last stage of development. Walking and talking have marked instinctive bases, and yet it is useless to try to make the infant of two months walk or talk. Even appropriate stimuli fail to evoke instinctive responses before their time. The psycho-physical basis for many responses requires a long period of maturing. At

eighteen months the average child is both walking and talking without other help than opportunity. So it is with all but a few of the most necessary instincts and capacities.

Some instincts are *transitory*, and if appropriate exercise is not afforded them at or near the nascent period they tend to weaken or disappear altogether. Thus, tendencies to play, to be curious, to fear, to desire companionship, and many others which have an unquestioned instinctive basis, may all be decidedly weakened or impaired if at appropriate ages the situations which call them into activity are lacking. The inborn tendency to acquire oral speech, so strong between the ages of one and three, wanes decidedly after seven years if for any reason, such as deafness, speech cannot be easily acquired during its nascent period. The tendency to climbing, shown so strongly by many children, is by others largely or entirely missed if favorable opportunity is not at hand at the appropriate time. The innate tendencies toward distinctly personal religious expression, normally culminating at adolescence, if not given encouragement or opportunity for expression at or before this age, are likely not to be shown later.

The instincts of human beings are more *indefinite*, *imperfect*, and *variable* than those of any other species. In general it may be said that the degree of definiteness, perfection, and fixity of instincts is proportional to the position in the animal series occupied by the animals possessing them. In the main it is true that the lowest forms of life have the most definite, perfect, and unmodifiable instincts, while the instincts of man possess these characteristics in the least degree. The instincts of insects are most strikingly complete, exact, and uniform. The nest-building activities of the wasp, the oriole, or the squirrel are infinitely more definite and invariable, and more perfectly adapted to the ends they serve, than those activities by which untrained man pro-

vides shelter for himself and his family. Similarly the means employed in self-preservation, the objects toward which curiosity is shown, and the manifestations of the pugnacious instinct are much more variable and indefinite than with any other form of animal life.

Again, some innate tendencies are *periodic*. The more significant factors in periodicity are the daily and seasonal rhythms and the temporary bodily conditions. The nest-building and migratory tendencies of birds, the hibernation of the bear, and the seasonal mating of many animals are good illustrations. With human beings periodicity of instincts is not lacking, but owing to the complications with habits and ideas are not so evident. Those centering in the sex instinct are perhaps the most striking.

Complexities of human activities. The activities of human beings are much more complex than those of any other form of life. The assertion that they have more instincts than any other animal, made many years ago by Professor James, is a widely accepted view. A wealth of innate tendencies is the natural correlate of a complex life. The possession of many instincts is, however, not the most striking difference between man and other forms of life. The human infant is less well equipped at birth and is less dependent throughout life upon his own instincts than any other being. Major Powell, in his *From Barbarism to Civilization* (p. 97), pictures the condition of the newborn infant in these words: "Every child is born destitute of the things possessed in manhood which distinguish him from lower animals. Of all industries he is artless; of all institutions he is lawless; of all languages he is speechless; of all philosophies he is opinionless; of all reasoning he is thoughtless; but arts, institutions, languages, opinions, and mentations he acquires as the years go by from childhood to manhood. In all these respects the newborn babe is hardly the peer of the newborn

beast; but, as the years pass, ever and ever he exhibits his superiority in all the great classes of activities, until the distance by which he is separated from the brute is so great that his realm of existence is in another kingdom of nature."

John Fiske did us an important service when, in his *Outlines of Cosmic Philosophy* (1874), he forcefully called our attention to the fact that the helplessness of the human infant, as compared with the young of other species, is a necessary condition of his becoming human. The inadequacy of his instincts throws burdens upon the supplementary instincts of his parents which have been the largest factor in the institution of the human family and of the whole social order. What is not cared for by instinct must be met by habit, by intelligence, and by reason. The human instincts are fortunately inadequate, variable, indefinite, and plastic, for thus and thus only has human progress been possible. If the instincts of an animal are absolutely fixed and invariable, if they are all present at birth, and if they are ample and adequate to meet all the essential needs of life, the door to habit formation, to intelligent, voluntary activity, the door to education, is forever closed to that animal. Recent studies of instinct have pretty conclusively shown that with no animal is the case quite so extreme as our statement may seem to imply, but it is unquestionably true that the capacity for training, for education, and for advancement is directly proportional to the plasticity of innate tendencies. The rapidly changing conditions of human life continually demand new adjustments. Life's most significant and important problems are no longer met by instinct, but by the use of deliberation and intelligent response.

In making clear the inadequacy of human instincts we must not obscure the equally important fact that strong innate tendencies lie at the basis of all activities of man,

whether high or low. "Take away these instinctive dispositions," says McDougall, "with their powerful impulses, and the organism would become incapable of activity of any kind; it would lie inert and motionless like a wonderful clockwork whose mainspring has been removed, or a steam-engine whose fires have been drawn. These impulses are the mental forces that maintain and shape all the life of individuals and societies, and in them we are confronted with the central mystery of life and mind and will." The instincts have been the means of man's preservation and evolution to higher and higher stages, and yet the way to future advance lies in the main over the difficult road of elimination of some, the redirection of others, and the control of all the instinctive tendencies by the higher thought processes.

Instincts and emotions. The emotions are all related to instincts. They are the feeling aspect of instinctive reactions. For the most part instinctive responses are continued when satisfaction and pleasure result, or when dissatisfaction or pain can thus be avoided. In short, all of them are modifications of the primitive pleasure-pain responses. Many of the specific emotions are characteristic of particular instincts. In some instincts the emotional element is so strong that some writers have even given the name of the emotion to the instinct; as, for example, those who speak of the "instinct of anger," or the "instinct of fear." The relationship between instincts and emotions is one of correspondence. A few of the more striking illustrations, as given by McDougall (27, pp. 121 ff.), will make this relatively clear. The instinct of flight is accompanied by the emotion of fear; the instinct of pugnacity, by the emotion of anger; the instinct of repulsion, by the emotion of disgust; that of curiosity by the emotion of wonder; the parental instinct, by the tender emotion. It is a mistake, however, to assert that all instincts are accompanied by emotions so peculiarly

characteristic. This is clear when one attempts to name the emotion which is peculiar to the social instinct, the instinct of acquisition, or the instinct of general physical activity. It is still more difficult to make out such definite correspondence when one comes to deal with complexes of several instincts in a single response. Here the emotions also become highly complex. Thus originate such emotions as awe (admiration plus fear); reverence (awe plus gratitude); scorn (anger plus disgust); and other complex emotions such as contempt, loathing, jealousy, envy, or appreciation of the beautiful.

Since the connection between instincts and emotions is so close, it should be evident why children are in very early years incapable of experiencing such complex emotions as gratitude, reverence, the æsthetic emotions, or even some of the more fundamental ones, such as love for the opposite sex. These emotions have their birth with the instincts to which they correspond, and depend upon experiences which cannot be had until these instincts have begun to function. The laws of physical and mental growth, therefore, condition the capacity to experience many of the emotions, because they condition the birth of instincts apart from which the emotion cannot be experienced.

From the fact of the close relationship between the emotions and the instincts it should be clear that since the instincts dominate much more of the behavior of children than of adults, the emotions also are normally relatively stronger and less well controlled in childhood. Periods when many instincts are coming to their full strength are therefore periods of emotional stress as well. This is peculiarly the case in early childhood and at adolescence. The emotions are best studied at these periods because more spontaneous and unrestrained. No one has so well commented upon this fact as Hall (15, vol. 2, pp. 59-60), who has offered trench-

ant criticism of attempts at analysis and description of the emotions by psychologists. If we ever learn the true essence, meaning, and significance of the emotions, it will be by the direct study of their objective manifestation in childhood and adolescence. Their proper evaluation and use in life and in education is largely a problem of the future.

Classification of instincts. Human instincts are highly complex, and, as may be anticipated from our discussion of their characteristics, are not easily classified. The classifications offered by various writers differ widely with their different theories and points of view. Many of these have been carefully studied in the light of the best conceptions of instinct presented to us by present-day biologists and psychologists. We have repeatedly tried to formulate a satisfactory classification of our own. The result of such efforts has been the growing conviction that satisfactory classification is impossible. We shall, therefore, not attempt to offer an original grouping, nor shall we advise the reader to attach any great importance to the classifications found in the literature. If any of them are of help to a better understanding of the instincts and their place in life, there can be no objection to their use so far. We would warn the student, however, of the serious danger of being misled and hindered rather than helped by many of them.

A brief statement of the reasons for our position may not be out of place. To classify instincts, as Mark (39, p. 135) does, into: (1) those primarily motor — climbing, fighting, etc.; (2) those that are chiefly intellectual — curiosity, general mental activity, etc.; (3) those with strong accompaniment of emotion — fear, pugnacity, sex, etc., — seems to the author to be not only artificial, but actually misleading. To make the predominance of one or other of these elements the basis of classification tends to obscure the fact that all instincts have all three elements. To classify them, with

Holmes (39, p. 135), as, (1) sympathetic; (2) æsthetic, and (3) scientific, tends to encourage the loosest possible use of the term *instinct*, which tendency we are attempting to combat, as well as to imply for them a teleological origin. Even such convenient, and perhaps we should say useful, classifications as that of Kirkpatrick (24), and the slightly modified forms of it that appear in many other sources, from the standpoint of their functions into (1) individualistic, (2) parental, (3) social, (4) adaptive, (5) regulative, and (6) miscellaneous, tend to commit us, if we accept them, to the teleological view of the origin of instincts or the still more doubtful one of "lapsed intelligence." The failure of such classifications is indicated by the fact that there has to be a "miscellaneous" group into which to dump all those instincts that defy classification.

Other classifications might be cited, but here we have one of the least and one of the most satisfactory. All tend to be logical, artificial, or arbitrary rather than natural or psychological, and worst of all to be more or less misleading. The reason is not far to seek. The nature of the stimuli and of the situations evoking instinctive responses, in human beings especially, are exceedingly varied and complex. The responses themselves are even more so. A given response is often the result of the simultaneous action of several instinctive tendencies. Age, sex, bodily condition, habit, volition, the nature of the accompanying consciousness, all tend to complicate the situation still further, so that it is difficult to say whether it is primarily an instinctive act, a habit, or a voluntary act, or, as is usually the case, no one of these, but a combination of all of them.

In spite, then, of the disappointment some will undoubtedly feel that no logical classification of instincts is offered, we must leave the matter thus unsettled. We are strongly convinced that all too often, in the difficult field of human

psychology, a definite, logically formulated, easily memorized classification of phenomena gives the student a sense of certainty, of finality, a feeling of understanding altogether detrimental to real appreciation of the complexity of the phenomena in question. Classifications are of value if they help one to think more clearly; they are detrimental if they confuse and mislead. The student's greatest need in this field is an appreciative understanding of particular instincts and capacities in their concrete manifestations, a clear notion of the relation of instincts to habits and voluntary acts, a knowledge of their relation to physical and mental development, to the learning process, and to education in general.

General pedagogical bearing of non-learned behavior. Since all conduct is conditioned by innate tendencies, all acquired by non-learned behavior, it is extremely important to know all we can of the innate tendencies of human nature. The emotional element of most instincts is so strong that it is self-evident that most of the interests are conditioned directly by instinctive-emotional complexes. We cannot understand or anticipate interests, then, without an understanding of their inborn correlates. Since instincts have their birth at certain fairly definite times, ripen in fairly definite order, and since many decline similarly, if we try to "strike while the iron is hot," as James figuratively states it, we must know the nascent periods of all important instincts and the interests related to them. These are the times favorable to the establishment of worthy interests, and for filling the mind with valuable knowledge concerning them.

Quite as true is it, on the other hand, that we must know the nascent period, the normal course of development, the ordinary exciting stimuli, and the relation to other tendencies of all those instinctive responses that are wholly or

partially undesirable under present conditions of life, so that we may the more surely prevent their becoming hardened into habits. There is a favorable time to acquire knowledge of the physical world of things, knowledge of self, and knowledge of moral and ethical standards that govern the relations of people.

There is a favorable time to acquire skill in speech, in walking, in drawing, in musical technique, etc. There are favorable times to establish permanent lines of worthy interests in healthful games and sports, in industrial occupation, in the broader scope of human affairs, in the arts, in nature, in reading, and in the sciences. There are relationships between the innate tendencies and all these fields of knowledge, skill, and interest which teachers and parents cannot afford to ignore. "To detect the moment of instinctive readiness for the subject is, then, the first duty of every educator" says Professor James (22, vol. 2, p. 402).

So, too, there is a favorable time to safeguard the child against harmful domination by his instincts. Having a knowledge of the innate tendencies and of the times at which they commonly appear, the educator has the additional obligation to further their control. There are three commonly accepted methods by which this is to be accomplished.

(1) *By use* and the association of satisfaction with a response, it is developed and hardened into habit. For example, when the innate tendency to locomotion has reached its nascent period, the habit of walking will be readily acquired if only opportunity is afforded. The innate tendencies to linguistic expression are so strong that the habit of speech is acquired in a few months under reasonably favorable conditions. At the appropriate time the habit responses involved in the game of baseball will find the strongest kind of backing in instinctive tendencies.

(2) *By disuse*, direct opposition, or association of displeasure with its exercise, the tendency to an undesirable response may be eliminated or minimized. Carefully protect a child from all the well-known occasions for instinctive fears and he may escape a host of groundless ones; let him learn that outbursts of anger bring only displeasure and deprivation and the outbursts cease or become less frequent; punish promptly and suitably, if no better means are available, when he is destructive and a bad habit may be prevented. On the other hand, it must not be overlooked that many desirable habits for which there is the strongest instinctive backing are never formed because the favorable period passes by unused.

(3) *By redirection or substitution*, desirable responses are grafted upon the stock of those that are undesirable, or undesirable responses are inhibited by the exercise of desirable opposing ones. Put the destructive child to work at some useful constructive enterprise; help the boys, whose sole desire is to fight, to organize a baseball or basketball team and work off their energy in accord with rules; turn the mischievous gang into a club with worth-while activities to carry out, enlist the members in a company of Boy Scouts, or furnish any legitimate outlet for its energy and genius, and often the desired control is attained. Help the boy all throughout his childhood to build up regular habits of eating, of sleep, and of exercise in the open, habits of industry and effort; help him to cultivate high ideals of cleanliness of body and purity of mind, of bodily perfection, honor, virtue, respect for parents, for women and for childhood; and, if you succeed, you need have little fear but that you have built up sufficient check against anti-social manifestation of the sex instinct at adolescence. Thus often is control prepared for long ahead of the time of special stress.

All of these methods must be used in appropriate ways and at the right times if innate tendencies are to be of aid to education. The choice of method is often difficult, and cannot, in most cases, be prescribed in advance, since individual differences in the time, strength, and persistence of the instincts themselves complicate the task. As a rule, positive and active means of control are superior to merely negative ones. Use, therefore, where possible, and especially redirection and substitution of instinctive tendencies, are the best methods.

Some inborn tendencies of greatest educational value. Among the instincts and complex innate tendencies we have time to single out only a few for brief consideration. In later chapters we shall in some detail discuss such activities as play, language, drawing, and the moral responses, none of which can be called instincts proper, but all of which have marked instinctive bases. So, too, in discussing suggestion, and in our treatment of various mental processes the bearing of inborn tendencies will often appear.

The innate tendency to general physical activity. Of all the inborn tendencies none is of greater importance for education than that to respond in motor activity to the influences of environment. From birth, and even before birth, impulsive movements — movements without external stimulus — give evidence of the capacity of the child to be active, and through activity to come into educative relationship with his environment. This is the essential mark of life itself. Spontaneous movements of hands, arms, legs, stretching of the body, apparently purposeless movements of the eyes and head, facial movements, vocal play, and many others are among the simplest and earliest manifestations of this tendency. Without such tendencies education and training could do nothing. This is the raw material with which education begins. In a very true sense

education itself consists in the changes made in an individual through his motor responses. Nothing has been more clearly revealed in our study of child life than that education "comes in through the muscles."

Movement is older phyletically and individually than mental activity, and is the indispensable correlate of the latter. This fact the teacher should never lose sight of. When it comes to be fully understood, the place and function of manual and motor activities in education will be more clearly appreciated than is now generally the case, and such activities will never be considered as secondary, but rather as cardinal. Improvement of motor responses, acquirement of skill, poise, and control of body are not so much the result of education as they are the essence of education itself. Our increasing understanding of the physical nature of children and of their instinctive tendencies has made it very clear "that mind and body have evolved together in the race, and have developed together in the individual, in one continuous process" (35, p. 15). Several of our succeeding chapters will tend to make this still clearer.

Curiosity. The impulse to attend to, to approach and examine, things about which there exists an element of uncertainty, is by all admitted to have an instinctive basis. It is characteristic of many higher animals, and is exceptionally strong in the monkey and in man. With both the latter it is accompanied by a strong tendency to manipulate objects that are new or not well understood: so much so that the expression "to monkey with" has become a very common colloquial expression for meddling curiosity. As McDougall (27, pp. 57-59) and others have shown, it is often operative in close connection, and often in rapid alternation, with the instinct of flight. For this reason it is sometimes hurtful and even destructive to the individual, as when the antelope comes within rifle range at the waving of

a red bandanna from behind a rock, or when the boy loses a hand in his attempt to see what is in the cannon cracker.

The strength of the tendency differs greatly with the individual. It is a marked trait in the explorer, and in those of scientific bent. Its correlation with intelligence has not been made out, but there are reasons for thinking it may be high. With man the tendency extends itself to investigations and explorations in the realm of the mental as well as of the physical. It is the motive for intellectual as well as physical endeavor. It brings about the expenditure of energy and effort in manifold ways, and often to almost limitless degrees. It has been an important motive of much of the scientific research, geographic exploration, and intellectual speculation that have added so much to the sum of human knowledge. Hall (15, vol. 2, p. 449) speaks of curiosity as the "bud of mind," basing his statement upon the study of the natural histories of many of the instincts and emotions which he and his students have carried out. His study with Dr. Smith (18, p. 84) of *Curiosity and Interest* seems to show that both the tendency itself and the objects exciting curiosity vary with age, sex, experience, training, and with the other instinctive tendencies present, and perhaps with other factors. Its stimuli are first largely sensory, but become, with perhaps minor fluctuations, increasingly intellectual with age. Among the more common manifestations in infancy are passive and active staring, listening, the passion to touch, to taste, to handle, to ask questions, to destroy, and the like. Later come the tendencies to constructive experimentation, the making and working of puzzles, teasing, desire for travel which leads often to truancy, and many others. Even serious social and moral offenses, committed "to see what will happen," are not infrequently initiated quite as much by curiosity as by any other cause.

Curiosity bears very close relation to attention and interest, to which the latter quite largely owe their strength and direction. This relationship we shall further consider in other connections.

The variety of exciting causes and the resultant non-specific character of the responses is the chief reason why some writers, as Parmelee (34), object to calling curiosity an instinct. These characteristics, however, make this tendency, which even he admits to have a strong instinctive basis, all the more useful for the purposes of education. There is almost nothing worth while about which curiosity may not be aroused in due time. In a sense the objects toward which curiosity is spontaneously shown seem, as Hall and Smith (18, p. 136) hold, to mark for us the "intellectual nascent stages" and the ripening of new instinctive tendencies. These should give the teacher his cue, for certainly the acquisition of knowledge under the spur of spontaneous interest and active curiosity is far easier and more effective than that which is enforced without them. "It may be that we shall some time come to reflect that forcing knowledge upon unwilling minds that are unripe for it is immoral" (18, p. 137), and that "curiosity is the active factor in the development of attention, and lack of it shows either mental deficiency or bad pedagogy" (18, p. 139).

General mental activity. The most distinctively human capacity is the inborn tendency to diverse and manifold mental activity. As Thorndike (46, pp. 141-43) has shown, there appears to be an inborn satisfyingness in mental activity itself apart from that connected specifically with exercise of particular instincts. More than any other tendency this makes possible the extension of human knowledge and the evolution of mind itself. Mental tendencies are quite as much non-learned as are motor ones. The two are definitely interdependent, as has already been indicated.

Instinctive motor responses initiate, condition, and elaborate mental processes. There is continuous action and reaction of mind and body. Many types of mental response are quite as characteristic, uniform, and essentially instinctive as are the bodily activities which are their usual counterpart. Without such inborn tendencies education has no point of departure or means of effecting changes in human nature. Almost the whole of intellectual development consists in growth, control, and redirection of inborn tendencies to observe, pay attention to, and think about environment and what it brings to the senses. The skill of the teacher consists largely in ability to select wisely and present appropriately the best stimuli to call forth the kinds of native mental reaction that are most worth while.

The social instinct. Another innate tendency that has much significance for education is that which shows itself in desire for companionship, in the gregariousness of the gang, clique, set, club, or society, in coöperativeness, in rivalry, competition, and emulation, in love of approbation and in readiness to sacrifice self for the good of the group. All this group of tendencies are in the main non-learned. They are of the utmost importance to the establishment and maintenance of human institutions; they form the chief stimulus to the development of most of the important human capacities; they condition habits, interests, and ideals.

To say that these tendencies are innate does not preclude the necessity of their definite training. Education and training must direct, control, and utilize them to further ends and ideals which the experience of the race has proved desirable. The school has as yet hardly begun to utilize as its ally the native social impulses which can be easily turned by skillful and proper direction into educational and civic assets of the highest order.

QUESTIONS AND TOPICS

1. What are the essential elements of an instinctive act?
2. Give illustrations of human reflexes, instincts, "activities with instinctive basis" (complexes).
3. State the more striking characteristics of human instincts and innate tendencies.
4. Why are human instincts so difficult to classify?
5. In what ways must teachers deal with instincts or innate tendencies?
6. Take some one human instinct or innate tendency and show its educational values.
7. Why is a thoroughgoing knowledge of instincts an essential qualification for all who would deal effectively with children?
8. Is the effort we have made to reclaim the term instinct from the extremely loose usage now current futile or worth while? Why?
9. Why, if instincts originated as practically serviceable responses of real value, do we now have to spend so much effort ridding ourselves of many of them? Should we not be better off without instincts?
10. Make an accurate explanatory statement of the relation of instincts and innate tendencies to delinquency.
11. What is the relation of instinct to attention? To emotion?
12. Observe the activities of a child of five or of nine years for an hour or a day and determine in how far they are instinctive.
13. Watch for instances in which the child himself attempts to control or uproot an instinctive tendency.
14. Make a list of instinctive tendencies with distinct educational values. Make another of harmful instinctive tendencies.
15. Is it ever entirely safe to "follow nature"?

SELECTED BIBLIOGRAPHY

1. Addams, Jane. *The Spirit of Youth and the City Street*. (1909.) 162 pp.
2. Baldwin, J. M. *Development and Evolution* (1902), pp. 61-80.
3. Betts, G. H. *The Mind and its Education* (1906), pp. 161-95.
4. *British Journal of Psychology*.
Volume 3, part 3, is devoted to the discussion of Instinct and Intelligence.
5. Calkins, Miss M. W. *A First Book in Psychology* (1910), pp. 170-208.
6. Cannon, W. B. *Bodily Changes in Pain, Hunger, Fear, and Rage*. (1915.) 311 pp.
7. Colvin, S. S. *The Learning Process* (1911), pp. 33-70.
8. Colvin, S. S., and Bagley, W. C. *Human Behavior* (1913), pp. 72-105; 126-64.
9. Darwin, C. *The Expression of the Emotions in Man and Animals*. (1886.) 374 pp.

10. *Dictionary of Philosophy and Psychology*, J. M. Baldwin. (1902.) See "Instinct" and also "Emotion."
11. Drummond, W. B. *An Introduction to Child-Study* (1905), pp. 194-235.
12. Freud, S. "The Origin and Development of Psycho-Analysis"; In *Lectures and Addresses on Psychology and Pedagogy, Twentieth Anniversary of Clark University* (1909), pp. 1-38.
13. Gesell, A. L., and Mrs. B. C. *The Normal Child and Primary Education* (1912), pp. 61-83.
14. Gross, K. *The Play of Animals* (1898), pp. 25-81.
15. Hall, G. S. *Adolescence*. (1904.) Especially vol. 2, pp. 40-231. See also index under Anger, Emotion, Fear, Feeling, etc.
16. Hall, G. S. "A Study of Fears"; in *Am. Jour. of Psy.*, vol. 8, pp. 147-249.
17. Hall, G. S. "A Study of Anger"; in *Am. Jour. of Psy.*, vol. 10, pp. 516-91.
18. Hall, G. S. *Aspects of Child Life and Education*. (1907.) 326 pp.
Several studies of innate tendencies by questionnaire method.
19. Hall, G. S. "A Synthetic Genetic Study of Fear"; in *Am. Jour. of Psy.*, vol. 25, pp. 149-200; 321-92.
20. Hall, G. S. "Freudian Methods Applied to Anger"; in *Am. Jour. of Psy.*, vol. 26, pp. 438-43.
21. Holmes, S. *The Evolution of Animal Intelligence*. Especially chaps. II-VI. (1911.) 296 pp.
22. James, W. *Principles of Psychology*. (1890.) Vol. 1, chap. iv, "Habit"; vol. 2, chap. xxiv, "Instincts"; chap. xxv, "Emotions."
23. King, I. *The Psychology of Child Development* (1903), pp. 42-70.
24. Kirkpatrick, E. A. *Fundamentals of Child-Study* (1903), pp. 51-247.
25. Loeb, J. *Comparative Anatomy of the Brain and Comparative Psychology* (1903), pp. 177-200.
26. Major, D. R. *First Steps in Mental Growth* (1906), pp. 72-123.
27. McDougall, W. *Social Psychology* (1909.) 389 pp. Especially pp. 19-89 on "Instincts," and pp. 121-58 on "Emotions."
28. Meyer, M. *The Fundamental Laws of Human Behavior*. (1911.) 241 pp.
29. Moore, H. T. "A Method of Testing the Strength of Instincts"; in *Am. Jour. of Psy.*, vol. 27, pp. 227-34.
30. Morgan, C. L. *Animal Behavior*. (1900.) Chap. III, "Instinctive Behavior"; chap. VI, pp. 235-82, "Feeling and Emotion."
31. Morgan, C. L. *Introduction to Comparative Psychology*. (1906.) Chap. XII, pp. 197-217, "Instinct and Intelligence."
32. Mosso, A. *Fear*. (1895.) 278 pp.
33. Myers, G. C. "Grasping, Reaching, and Handling"; in *Am. Jour. of Psy.*, vol. 26, pp. 525-39.
34. Parmelee, M. *The Science of Human Behavior*. (1913.) 443 pp.
35. Partridge, G. E. *Genetic Philosophy of Education* (1912), pp. 32-58.
36. Patrick, G. T. W. *Psychology of Relaxation*. (1916.) 280 pp.

37. Peterson, J. "Instinctive Tendencies in Man"; in *Psy. Bulletin*, vol. 13, pp. 412-16. (Annotated bibliography.)
38. Pyle, W. *The Outlines of Educational Psychology* (1912), pp. 85-185.
39. Sandiford, P. *The Mental and Physical Life of School Children* (1913), pp. 124-41.
40. Sisson, E. O. *The Essentials of Character*. (1910.) Chaps. 1-11, pp. 5-43, on "Native Tendencies and the Treatment of Native Tendencies."
41. Stratton, G. M. "The Control of the Fighting Instinct"; in *Am. Asso. for International Conciltation* (1913), no. 73, p. 14.
42. Sully, J. *Studies in Childhood* (1895), pp. 191-227. (Illustrative material.)
43. Sully, J. *Children's Ways* (1914), pp. 85-111.
44. Tanner, Miss A. *The Child* (1915), pp. 313-55.
45. Thorndike, E. L. *Animal Intelligence*. (1911.) 297 pp.
46. Thorndike, E. L. *Educational Psychology*. Vol. 1, *The Original Nature of Man*. (1913.) 327 pp.
47. Titchener, E. B. *Textbook of Psychology* (1907), vol. 2, pp. 471-503.
48. Tracy, F. *The Psychology of Childhood* (1909), pp. 75-92.
49. Walker, C. *Hereditary Characters and Their Modes of Transmission* (1910), pp. 49 ff.
50. Washburn, Miss M. *Animal Mind*. (1908.) 333 pp.
51. Wundt, W. *Human and Animal Psychology* (1896), pp. 381-423.

Note. Almost any standard text on psychology will contain chapters on Instinct and Emotion.

CHAPTER VI

THE PLAY OF CHILDREN

Play and work. Many attempts have been made to differentiate work from play. None of them is wholly satisfying. No hard-and-fast line can ever be drawn between these two forms of psycho-physical activity, since, as Thorndike (59, p. 67) has shown, precisely the same inborn tendencies give rise to serious occupations as lie at the basis of playful ones. Dewey (20, vol. 4, p. 726) stresses the same point when he says that work "is inevitably preceded by play and grows insensibly out of it." We may regard play as the characteristic activity of the child and work as the dominant one with adults, but this is of little help in making the distinction. Work and play have a common origin; objectively they often cannot be distinguished; subjective distinctions, too, are frequently by no means easy, for the purposes served by each and the emotional elements involved are by no means wholly unlike. Work, play, recreation, amusement, labor, drudgery, are terms by means of which we attempt roughly to differentiate the various forms of human activity. In spite of the difficulty of making these distinctions exact and accurate, there is value in the attempt in that our ideas of the nature of each and the uses it serves are perfected in the process. We can best attain our present purpose by presenting a few typical definitions.

"Work," says Parmelee (47, p. 252), "may be defined as being effort devoted to the production of things of value." Johnson (36, p. 25) remarks very simply that "work is the result of the force of habit." Hall (31, p. 116) contends that "work is menial, cheerless, grinding, regular, and requires

more precision and accuracy" than play, and that "the difference is essentially in the degree of strength of the psycho-physic motivations." Patrick's distinction is more detailed than most. He makes work "include all those activities in which by means of sustained voluntary attention one holds one's self down to a given task for the sake of some end to be attained other than the activity itself. Such activities involve mental stress, strain, effort, tension, concentration, and inhibition" (48, p. 476).

Play, on the other hand, is to Johnson (36, p. 25) "the result of the force of instinct." Parmelee (47, p. 248) makes it "the expenditure of energy purely for the sake of gaining pleasure without being directed toward any useful purpose." "The term play," says Patrick (48, p. 475), "may be applied to all those human activities which are free and spontaneous and which are pursued for their own sake alone." Hall's (31, p. 74) theory of play is involved in his statement that "I regard play as the motor habits and spirit of the past of the race, persisting in the present, as rudimentary functions sometimes of and always akin to rudimentary organs."

Careful examination of these and other definitions of work and play shows a general agreement that work is genetically later than play; that it is less certainly pleasurable; that it usually lacks the interest and spontaneity of play; is more certainly engaged in for the sake of remote ends apart from the activity expended in securing those ends; is less immediately related to the instincts, and therefore requires much greater exercise of such higher and lately acquired capacities as voluntary attention, concentration, and controlled and directed effort. There is also general agreement that each activity becomes more valuable as it approaches the other. As Brinton expresses it, "the measure of the value of work is the amount of play there is in it, and the measure of the value of play is the amount of work there is in it" (30, vol.

1, p. 231). Every endeavor to make work more economical of energy, less irksome, less menial and more whole-souled and satisfying, and every effort to make play serve the highest and best purposes of life which menial labor has alone been thought capable of attaining, the better it will be for both child and adult. Work should have interest and zest; play should be the most serious and useful business of children, schooling them to effort and concentration. The physiological energies involved are of the same sort; the objects attained are often not radically different; play is often carried to the point of exhaustion, as is work; suitable work can be most enjoyable and satisfying; play is not always solely its own end, neither is work always engaged in merely for the ends attained by it; one may form habits of play as well as habits of work; and thus every attempted distinction tends to break down at some point. In spite of all this, we still recognize in a practical, common-sense way that work is work and play is play, and we are not commonly mistaken as to which it is we are engaged in.

Theories of play. Why do children play? Ask the average child and you will probably find that he considers your question rather foolish and unnecessary. Chambers (12, pp. 720 ff.) asked 2481 children, ranging in age from six to eighteen years, "What game do you like to play best, and why?" The younger children considered it quite sufficient in justification of their favorite play to say, "It's fun"; "I like it"; "It's interesting." Such responses seem clearly to indicate that to them play is its own justification and sufficient excuse. Young children play because they feel like it. Few even of the older children appear to have given serious thought to the reasons underlying the attractiveness of play. With many the proposal of the question may have been the first occasion for serious consideration of the subject, if, indeed, it was seriously considered even then. Play

is clearly spontaneous, and has its basis in instinct, which from the child's point of view makes explanation unnecessary. Play is the child's life and that life is thoroughly enjoyable, and were it not for the instinctive curiosity of adults the matter might rest there.

But philosophers, physiologists, and psychologists, with their passion for explanations and their hope that any phenomenon well explained may throw light upon other perplexing problems, have sought completer theories of this self-revealing interest. Four theories have been stated with sufficient clearness to warrant mention here.

(1) *The Schiller-Spencer theory.* The poet Schiller appears to have been the first modern writer to propose a theory with sufficient merit to warrant retention in the literature of play. His theory, more scientifically formulated and defended by Herbert Spencer, is now known as the Schiller-Spencer theory. The German poet and the English philosopher held that play is due to the expenditure of surplus energy. They contended that since the young have most of their serious needs cared for by their parents, they have a superabundance or surplus of energy which must be expended in some way, and that this energy takes the form of spontaneous, more or less aimless or purposeless activity to which we apply the name play. Play is the result of the spontaneous overflow of pent-up energy into psycho-motor channels.

This simple theory has elements of truth. Healthy young animals do seem to have a superabundance of energy and an irrepressible tendency to expend it in ways which are often indefinite, purposeless and, to say the least, lacking in immediate utility. Undoubtedly the greater the surplus of energy the stronger the impulse to play. Excess of energy favors readiness of discharge into motor channels. The theory is, however, unsatisfactory both for what it

implies and for what it omits. The child is a playing animal whether he has surplus energy or not. He is not naturally quiescent. He does not stop playing when he has exhausted his surplus energy. He plays when recovering from serious illness, when his vital energies are not even sufficient to meet ordinary demands. He may, and at times does, use his surplus energy voluntarily in work as well as in play. He does not cease to play when he has entered the serious business of adult life. But the most serious limitation of the theory is that it gives us no explanation of the fact that play assumes characteristic forms many of which are largely independent of race, sex, training, imitation, and even age factors; nor does it suggest why the forms of play are uniformly different in definite ways for different species of animals: Such apparently aimless and purposeless plays as the grasping, kicking, pulling, and pushing movements of the infant; his joyful screams, cries, and babble; his crude manipulation of objects, picking up and throwing down, and the like, might be considered as fairly well explained on this theory. Such activities as hunting, fishing, wrestling, tree-dwelling, and cave-digging; such plays as those with pets, marbles, balls, and bats; such games as tag, fox-and-geese, and all those involving search and chase, as well as the whole repertory of imitative games, are left without adequate explanation.

(2) *The Groos theory.* In 1898 Groos published his voluminous work, *Play of Animals*, and three years later his *Play of Man*, in which a new theory was proposed. After exhaustive study of plays in both fields, Groos comes to the conclusion that play "is the agency employed to develop crude powers and prepare them for life's uses" (27, p. 375). The instincts of man, Groos thinks, are more numerous than those of any other animal, but also more inadequate in meeting the necessities of life in the "struggle for existence,"

since with man the intellectual powers have become more important and useful than the most perfect instinct. While the intellectual capacities are developing, and while the instincts are imperfect, the child uses both playfully to develop them. It is the imperfect and undeveloped state of the instincts that makes play necessary. Says Groos again (27, p. 377), "My own view is that there is no general impulse to play, but various instincts are called upon when there is no occasion for their serious exercise, merely for the purpose of practice, and more especially preparatory practice, and these instincts thus become specialized plays." The preparatory exercising of instincts for the purpose of perfecting them or transforming them into habits definitely helpful in meeting life's serious needs is for Groos the essence of play. Instincts have arisen by a process of natural selection of activities which, when practiced, prepare in particular and definite ways for the serious occupations of life. The child instinctively plays at what is later to be his work. On this theory those animals would have best chance of survival that, while young, play at activities which they must engage in as adults. The theory thus emphasizes the biological significance of play, and perhaps still more its educational significance.

This theory escapes some of the criticisms to which the surplus-energy theory is open, and to some of the critics seems fairly satisfactory. Play does unquestionably have its basis in instincts. All play does in a general way prepare for life's serious activities and some plays do so in specific ways. In so far as physical and mental capacities are given exercise, their development is furthered. Many desirable traits useful in any situation in life are developed by play; as, for example, self-direction, initiative, patience, persistence, courage, resourcefulness, concentration, ability to cooperate, power of inhibition, and many others. But with

Groos the preparatory function of play is apparently thought of in very much more definite and specific ways than these. The kitten's pouncing upon the rolling ball is preparatory to the pursuit and capture of food; the puppy's playful snapping, snarling, and biting are preparatory to self-defense and overcoming of enemies or prey at maturity. The doll play of the girl prepares her for the mothering of children. The hunting, fishing, and collecting plays of boys must be explained as preliminary practice for the serious occupation of providing sustenance for the family in maturer years. These happily chosen illustrations seem to accord fairly well with the theory. If children frequently chose in the end those occupations which as children they most persistently imitated, it would not be difficult to see that such plays could have a very definite preparatory value, but such choice is not now common. Again, if one chooses plays at random it becomes quite difficult, if not impossible, to trace any definite relationship between many of the child's most characteristic play interests and any of the present-day occupations of adults. As Patrick has well shown, many of the plays of children bear but slight resemblance to the life activities of adult man. Much more do they resemble the serious pursuits of our primitive and prehistoric forbears. Some of them resemble the sports, games, and recreations of adults more closely than they do their serious occupations. "The great body of children's plays find their significance, not in their likeness, but in their unlikeness to their future laborious duties" (48, pp. 472-73).

Other serious objections to the Groos theory can be only mentioned. Hall (31, p. 73) characterized it, soon after it was first proposed, as "partial, superficial, and perverse," and as ignoring "the past where lie the keys to all the play activities." It is objected that play is the "serious" business of the young just as work is of the adult; that play is

quite as important for the one as work for the other; that play serves present ends quite as much as future ones. The theory fails to account for adult plays, games, and sports. It has no explanation for the strong element of restraint which is one of the striking characteristics of the playful exercise of some of the instincts, notably the instinct of pugnacity in dog or boy (43, pp. 110-15). The elements of reasonableness and of truth in this theory must not blind us to the fact that play needs fuller explanation.

(3) *The recapitulatory theory.* A third theory of play goes under the name "recapitulatory." It has been chiefly supported by Hall and his students. Hall's first statement of this theory appeared in connection with his criticism of the Groos theory. According to the view of Hall (30, vol. 1, p. 202 *et seq.*; 31, p. 73 *et seq.*), play is to be explained in the light of the past. The young live over in play the serious activities of primitive and prehistoric man. Both the motor and the psychic motives of play are to be found in the remote past. "In play every mood and movement is instinct with heredity" (31, p. 74). In play "pleasure is always exactly proportional to the directness and force of the current of heredity, and in play we feel most fully and intensely ancestral joys" (30, vol. 1, p. 206). True play practices the old, not the new, activities of the race. Many of the play activities are atavistic and reversionary, tending toward entire disappearance, but still requiring, like the tadpole's tail, to be exercised in due time in order to stimulate the growth of later functions. In play "we rehearse the activities of our ancestors, back we know not how far, and repeat their life-work in summative and adumbrated ways" (31, p. 74). The distinctly recapitulatory element of the theory appears still more definitely in the following quotation: —

Thus stage by stage we reënact their lives. Once in the phylon many activities were elaborated in the life-and-death struggle for

existence. Now the elements and combinations oldest in the muscle history of the race are represented earliest in the individual, and those later follow in order. This is why the heart of youth goes out into play as into nothing else, as if it remembered a lost paradise (31, p. 74).

The chief superiority of this theory over the others consists in the fact that it explains the *forms* of play much more satisfactorily than they. The cardinal forms of play can, on this theory, as Hall asserts they do, remain the same from era to era in spite of complete changes in social and industrial conditions. The theory admits the preparatory value of play as a secondary function. It admits the partial truth in the superfluous-energy theory by showing that the tremendous psycho-motor impulsion back of age-long racial experience favors not merely the outflowing of energy in spontaneous play, but adds to and completes that theory by showing why this outgoing energy takes the form it does. It must be admitted that the recapitulatory theory upon which play is explained rests upon a very uncertain foundation, especially when it stresses the order in which racial activities are rehearsed. This theory also fails satisfactorily to explain the plays and sports of adults. Hall himself says (34, p. 517), "We have as yet no satisfactory psychological theory of what play means and what it does, and my own modest contribution here consists merely in the suggestion that if ever we have one it will regard play as for the most part regressive."

(4) *The relaxation theory.* Patrick, to whom all future theorists of play must acknowledge indebtedness, and whom Hall (34, p. 513) declares to "have the clearest conception of any one I know of the nature of play," has recently elaborated what may perhaps be called the "relaxation theory," although this term does not adequately or quite fairly represent it. His forceful criticisms of the

earlier theories, and his concrete application of his theory to such games as baseball, football, golf, and many simpler plays and games, lead one to give serious consideration to his three propositions concerning a satisfactory theory of play: —

1. That play is free, spontaneous, self-developing, and self-rewarding, and is inclusive of practically all of the child's activities and many of those of adults.
2. That child play and adult sport should be closely correlated and explained on the same principles.
3. That the play activities of both child and adult "tend to take the forms of old racial activities, involving brain tracts that are old, well-worn, and pervious" (48, p. 477).

Patrick holds that the essence of work is found in the presence of sustained attention, controlled association, concentration, and analysis, together with inhibition of impulses. These are the capacities that have made for progress in civilization, but in children they are undeveloped, in adults only partially so, and in any case the use of them is excessively and rapidly fatiguing. Energy available for play, therefore, takes the line of least resistance. The plays of children and the sports of adults take the form of those racial activities which are oldest, simplest, and most elemental, because, "the more elemental these activities have been in the history of racial development, the greater release they afford when indulged in as a relaxation from the tension of modern life" (48, p. 477). Children play, and their play takes the simple, elemental forms it does because the higher capacities involved in work are not yet developed in them. Adults engage in games and sports, or participate as interested spectators at ball-games, prize-fights, horse-races, or at the theater, because to do so gives

relief, rest, and recreation from the stress and strain of work. Both play at activities which are alike elemental and primitive because such activities are natural, spontaneous, satisfying and pleasurable. The essence of play on this theory is its recreative, regenerative, and hygienic character.

As an illustration of the application of the theory, Patrick shows how in baseball three elements are involved which are among the oldest and oftenest repeated activities of the human race, and which give an exhilaration and emotional stir such as few activities do. They are throwing, striking, and running. These are activities which were begun in the infancy of the race, when man was learning to defend himself from wild animals and hostile men, and to secure food by throwing missiles or chasing and striking his prey with a club. The brain tracts involved are, therefore, "old, well-worn, and pervious," and to engage in a game involving such activities is highly satisfying and recreative, especially when the game involves still other such elements as competition, rivalry, personal encounter, coöperation, and excitement of primitive emotions. The passion to play with fire, which Chase (13) found to be the most popular play on the streets of New York City, can well be accounted for on this theory if we consider the tremendously important place fire has had in the life of both primitive and civilized man.

What children play. The number of statistical, observational, and questionnaire studies of play has been quite sufficient to reveal the chief play interests, their character, their variety, and the changes in them with age, sex, race, environment, season, and other factors. Not the least striking fact about plays and games is their wonderful variety. Johnson (36, p. 101) lists and discusses something like five hundred and seventy-five games, which was about half of those the names and descriptions of which he col-

lected. Croswell (16) found that his two thousand Worcester school-children, equally divided between the sexes, named over seven hundred plays and games which were current among them. This list omits most of the plays of infancy, probably many of those not current at the season of the year when the study was made, and is unquestionably for other reasons an incomplete list even for the school-children of that one city. All studies show similar profusion of the forms of play; in fact, almost no limit can be set to its variety. Even the list of traditional games passed down from generation to generation is a very extended one, as the various excellent books of plays and games show. Johnson (37) describes more than one hundred games of chasing, hunting, throwing, and shooting alone which he considers suitable to early and later childhood, and his list is confessedly incomplete. This is only one of many groups of games. The activity of children in play becomes increasingly diversified from infancy till well into later childhood, when it tends to become more circumscribed. Croswell places this change at about twelve years. The activity of the average adult is astly more restricted than that of children. The greater diversity of activity in childhood promotes an all-round, many-sided development, and strongly favors the view of those who give play this function.

In spite of the almost bewildering variety of plays and games, closer examination reveals the fact that the general characteristics of the play are strongly alike for all children of the same age, regardless of race or environment. The essential character of play is subjectively determined, but the external form in which this essence is clothed may be varied greatly by external influences.

Play as affected by age. No other factor so directly affects the nature of play as does age. Each period of childhood has not only its characteristic plays, but the nature of

the plays and games themselves are distinctly different in each. In games that persist through several periods, the interest culminates at rather definite times. Examination of

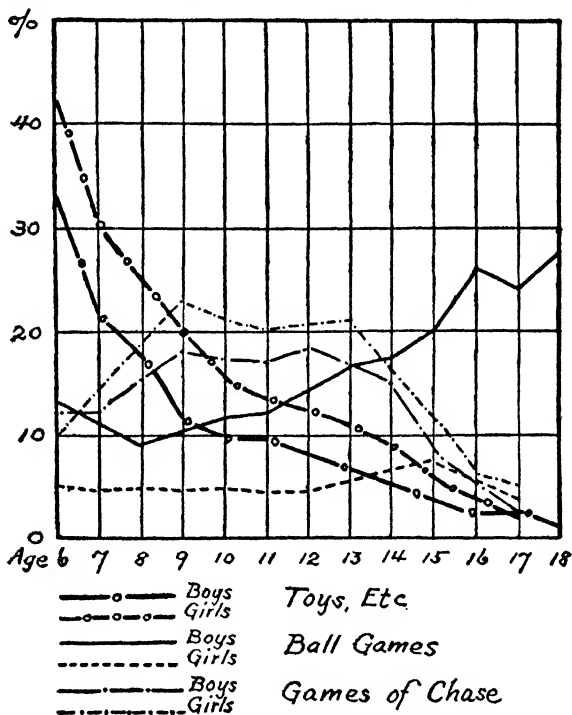

FIGURE 7. INTEREST IN VARIOUS GAMES

(After Crowell, *Pod. Sem.*, vol. 6, p. 330, by permission of G. Stanley Hall.)

the curves for different plays and games reveals three or four types of curve. There are plays such as that of girls with the doll, as studied by Ellis and Hall (32), in which from relative insignificance the interest rises rapidly to a culmination at a rather definite age, and then as rapidly declines

almost to extinction. There are others, like the toy interest, which have great prominence very early and decline steadily throughout the entire period of childhood. Others follow in the main the course of ball-games, which with boys rise steadily from insignificance to a prominence which they retain into adult years. Or, on the other hand, they may follow the course of the ball-games as in the case of girls, with whom they never become a prominent interest, but one which remains essentially constant throughout the years from six to seventeen. The accompanying graphs illustrate these various tendencies.

There are several reasons for the change of interests with age. We have already pointed out in our discussion of instincts that certain instinctive tendencies are delayed in appearance, that some are transitory in nature, and that all tend to show so-called "nascent stages." Physical and physiological conditions are the chief internal factors which determine the functioning of instincts. The attainment, therefore, of a certain degree of physical and physiological development with the consequent appearance of accompanying instincts is the important consideration determining whether a given play or game is likely to be engaged in. Plays suitable to a certain age can be chosen only when one has definite knowledge of the physical and mental traits of the period, and, on the other hand, these traits are revealed by the nature of the spontaneous plays. In his characterization of the play periods, Johnson (36) makes a comprehensive survey of such facts as a background for, and explanation of, the plays and games of each period. This close and necessary relation between play and the instinctive physical and mental capacities is one important reason why a study of spontaneous play gives such valuable insight into the actual nature of childhood. This relationship is best seen when we observe the character of the activities of each period.

Infancy (0-3 years). The characteristic plays¹ of infancy are those of sensory and motor experimentation. Any objects, including the parts of his own body, that serve the purpose of stimulating the senses of touch, sight, hearing, taste, smell, or temperature will be persistently used by the infant for that purpose. Handling, pulling, pushing, sucking, tasting, dropping, picking up, pounding, climbing, running, swinging, exploring, and, in the latter part of the period, simple imitative and dramatic activities, and many similar responses, give suitable and pleasing exercise to muscles and sense organs. There are no games, the plays are largely formless, the interests varied and fleeting. The description by Major (41) of what the baby did in forty-five minutes gives an excellent idea of the play of this period. Toys, liberally defined, absorb almost the whole of the infant's time and energy. The typical mother plays, peek-a-boo, pat-a-cake, finger plays, and the like, add an element of companionship that is early a definite need. Companionship is enjoyed, but is less necessary than at any later period. The infant, too, desires companionship for what he can get rather than what he can give. It is not an altruistic social impulse that he here displays. The activities of the period are almost purely individualistic, self-centered, even selfish, and their results are chiefly development of the sensory capacities and the fundamental muscles.

Early childhood (4-7 years). The plays of this period continue, elaborate, and perfect the activities of the preceding one. There is in fact no sudden break, but rather an evolutionary change from period to period. In early childhood, as in infancy, play is more truly its own end than at any later age. The activities themselves, rather than any

¹ In the characterizations which follow we are indebted chiefly to Johnson's (36) *Education by Plays and Games*, which may be consulted for fuller statements.

remote or even immediate ends attained by them, are the important interest. Imagination becomes increasingly active and imitation assumes an important rôle, so that simple dramatic and representative plays become numerous. Pleasure in companionship increases, but individual desires dominate, and the presence of a playmate calls forth little coöperation, rivalry, or competition. The growing need for companionship, however, makes play a great social teacher, developing speech, curbing selfishness, and paving the way for complete socialization. Toys still absorb on the average something like half of the child's time and interest, but the use made of them indicates a growing ability to control the larger muscles, to construct, to build, and to attain definite ends in play, although interests shift rapidly and there is little persistence in accomplishment of difficult ends. Absorbing constructive efforts of one hour or one day are often forgotten for others the next. On the other hand, such studies as that of Miss Sisson (53) show that at the kindergarten age a stable environment may result in the persistence for weeks of very simple plays, which are repeated over and over with never-ending interest. Curiosity and questioning are dominant impulses, which give point and form to, and stimulate or keep alive, many playful activities that exercise all the rapidly developing physical and mental capacities. No better index in fact can be had of the progress in these directions than that indicated by the changes in the nature of play.

Later childhood (8-12 years). This period is both physically and mentally one of readjustment and transition. Growth is slower than in either the preceding or the following periods. The later years are years of relative and increasing stability physically. The brain attains almost its mature size, and development of its functional capacity is advancing rapidly. Energy and vital capacity increase

steadily toward the close of the period, so that both morbidity and susceptibility to fatigue decrease. This is the most active period of the child's life and more games are played than at any other age. Curiosity and active questioning of persons and things continue. Imagination, although active, is more controlled and constructively creative than earlier. Imitation takes new forms and becomes more purposeful. The motor aspects of play still dominate the intellectual, though the latter steadily increase in prominence. Effort is expended in more meaningful, definite, and constructive ways, and in activities which increasingly demand skill. As skill increases, individual competition and rivalry enter prominently into play, and his games never more truly reveal the child's real nature than now. The increasing proportion of games, as contrasted with plays, calls for obedience to rules and makes companionship more necessary. Regard for law and for enforcement of law greatly increase, but the laws of our complex adult civilization never rest more lightly on the shoulders of the child than at the close of this and the beginning of the next period. Real coöperation develops late, and the games are loosely organized and involve individual rather than group competition. The games, interest in which culminates during these years, are a valuable index to the nature, capacities, and traits of the player. Notable among the culminating interests are the doll and house plays of girls, all the loosely organized games of chase, many traditional games, the simple ball-games, collections, pets, puzzles, stumps, stunts, etc.

At the close of this period and the beginning of the following, the boy, especially, is never more unlike the civilized adult. Never does he care more for the companionship of those of his own age and sex, nor less for that of those younger, older, or of the opposite sex. Lee (40) calls this the "Big Injun" age, and many students of play speak of the

period as one in which the physical and mental traits of the child bear striking resemblance to those of primitive man. Children are now keen, alert, more and more skillful, self-sufficient, have good control of their bodies, and are never less susceptible to domination in their play by their elders. Gangs, clubs, teams, and more loosely organized groups begin their dominating influence at eleven or twelve, restricting the number, but increasing the persistence, of the play and game activities.

Adolescence (13-16 years). With the dawn of adolescence and its sudden physical, mental, and emotional transformations, more mature interests arise. The gang or team dominates much of the play life. Competition is still keen. Stumps, stunts, athletic events, and field work make strong appeal. Socialization is rapidly effected. Coöperation in the adult sense is for the first time characteristic. Capacity for leadership and willingness to follow a leader are greatly increased. The capacity for subordination of self in the interest of the team gives evidence of an augmented appreciation of social relationship and a feeling of social obligation. The sexes begin again to mingle in many of their games, amusements, and recreations, and girls become interested spectators at the characteristic games of the boys. The interests of the adolescent rapidly approach those of adults and are soon to be accounted for on the same basis. The proportion of games with a marked intellectual element decidedly increases. Strenuous, active games are still a dominant interest, but not as in the preceding period to the extent of excluding most of the quieter indoor games. Decrease of active games is especially marked in the case of girls. Sex differences in games and plays, which are so marked at the beginning of the period, tend to decrease toward its close. With boys, especially, the racial activities of fishing, hunting, swimming, camping, exploration, adventure, and the

like are very prominent. In this, as in the preceding periods, many correlations can be made between games and the educative activities of the school with great advantage to the child. The teacher who understands, is interested in, and can enter into the play life of children, has a tremendous advantage over one who cannot.

Summarizing the effects of the age factor, it may be said that age tends to increase the number of games and amusements as contrasted with plays. It increases interest in some and decreases that in other types of plays and games. Social tend to take the place of individualistic games as maturity approaches. The complexity of physical and mental activities involved in plays and games increases with age and more definite and remote ends are sought. The intellectual elements in play become increasingly prominent, the player becomes more and more conscious of the values of his play to him, and to a limited extent may engage in certain games and athletic activities with the definite purpose of securing these values for himself. This is never true of young children. These and other changes with age make play a valuable index to the progress of mental and social development.

The sex factor. In infancy, sex differences are negligible. There are neither instinctive, physical, nor social reasons for differentiation of play interests. This remains relatively true during the period of early childhood if play is free, untrammelled, and the influence of older children and adults does not make itself too strongly felt. Boys enjoy house and doll play almost as much as girls, and the two will play together quite as happily as will either with those of his or her own sex. The beginning of school life, however, and especially the influence of social traditions, soon bring differentiation of interest after the age of seven is passed. Both physical and mental differences, too, increase with increasing age.

From seven years on, Croswell found that girls have a larger repertory of amusements which they regularly use. Boys are less affected by convention. Boys care more and more for games involving contest, strife, and mastery than do girls. Of the seven hundred plays mentioned by his two thousand children, Croswell found two hundred and seventy-two common to both sexes, one hundred and eighty-two mentioned by boys alone, and one hundred and ninety-seven

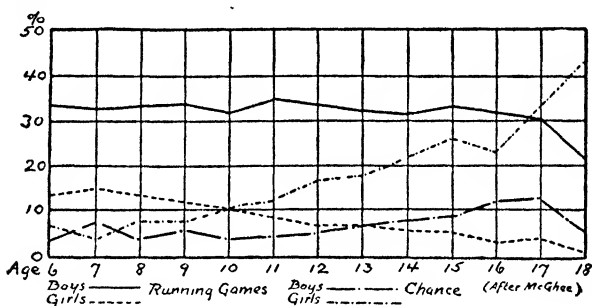

FIGURE 8. RUNNING AND CHANCE GAMES

by girls alone, the differences increasing with age at least till toward the end of the gang age, during which boys affect to despise the interests of girls and follow distinctly masculine ones. According to McGhee (44), who classified the choices of each sex by the elements involved in the games, boys prefer games in which running is the dominant element far more than girls at every age, the average difference being approximately thirty per cent, against five per cent. From nine years on, girls choose games involving chance much oftener than boys, the difference being ten per cent at thirteen, and thirty-five per cent at eighteen years. Girls exceed boys in choice of imitative games till thirteen by an average of about ten per cent. In choice of games involving rivalry boys exceed girls by an average of approximately twenty

per cent, with a tendency for this difference to disappear at maturity. In choice of coöperative games also boys excel at every age by more than twenty per cent, and maturity increases the disparity. Coöperation and rivalry increase, however, and imitation decreases with both sexes as age advances. The club and business life of men and women

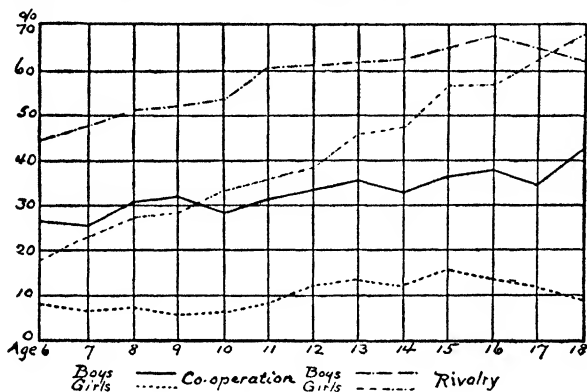

FIGURE 9. COÖPERATION AND RIVALRY IN PLAY

(Figures 8 and 9 are from McGhee's study, *Ped. Sem.*, vol. 7, pp. 459-78, reproduced with permission of G. Stanley Hall.)

show these same differences, and it remains to be seen whether the increasing participation of women in social, political, and industrial life will change this apparently inherent difference.

On the theories of either Groos, Hall, or Patrick, sex differences are natural and easily explained. In so far as the future life of the sexes is to be of necessity different, and in so far as the strength and variation of instincts, and of physical and mental traits and capacities are diverse, it could not be otherwise. Many students of play, however, are of the opinion that the girl suffers impairment of her best physical development because social custom, restraint, and conven-

tion too much interfere with what is natural and spontaneous. Without these influences the differences would be unquestionably less till thirteen than in reality they usually are. It cannot be forgotten in this connection, however, that in both physical and mental development girls outstrip boys of the same age, particularly in the years of early adolescence, so that the increasing differentiation of interests is in part due to this disparity. As maturity approaches, as intellectual interests increase, as the social nature develops, the sex differences again become somewhat less marked. The differences due to sex alone are sufficiently marked to merit attention and deserve consideration in the planning of any course in plays and games as well as in direction of spontaneous play.

Racial differences. There is a striking similarity in the essential features of play the world over, but still racial differences do appear. Croswell even finds such among children of different races of the same city where surroundings are relatively uniform, but is of the opinion that they are due more to family and racial traditions than to inherent differences in the children themselves. Gulick (29) contends that the Anglo-Saxon stock manifests more capacity for a richness, variety, and intensity of play, particularly of the coöperative and group games involving self-subordination, loyalty, and self-sacrifice, than is shown by any other racial stock. For these qualities he holds that "instinct appears to be less sufficient and tradition more important" (p. 143). It would seem that in a very true sense he who supervises the play of children, as well as those who write the stories and the songs, holds a very important place in shaping the destinies of a country. It has often been held that the character of Britain's greatest men has been formed by the play life of Eton, Harrow, Winchester, or Rugby, quite as much as by the activities of the schoolroom.

The racial factor is without doubt in part a matter of geographic location and climatic influences. Certain typical games of races living in the far North and in the extreme South seem to owe their existence and popularity to climatic influences. Once thoroughly established, tradition may carry them to other lands and climes.

The values of play. The values of play are as varied as the values of life. The physical, mental, social, moral, and religious natures all owe their debt to play. It is difficult to overestimate this debt. Play is the school of infancy and childhood without whose tutelage formal education could accomplish little. Preyer, from his intensive study of infancy, was convinced that a child learns as much in his first three or four years as in his whole university course. The time has passed when with our Puritan fathers we can look upon play as a waste of time. Rather it is the child who does not play whose time is wasted. Many books and special articles have recently been written to demonstrate the values of play. Both general and specific values have been clearly pointed out by Carr (10). We can here barely indicate these values.

The recuperative, diversional, and relaxational values of play have already been suggested in our discussion of Patrick's theory. If there were no other values, play would deserve a large place in the life of young and old and would find ample justification in the scheme of life. The greater the stress and strain of work, the greater the need of the relaxation which play most surely furnishes. Sorrow, depression, painful associations, and distressing circumstances are forgotten, and their detrimental effects are at least diminished by play as by nothing else. The fatigue incident to the deadening routine of many present-day occupations finds here its best antidote. Active plays and games increase the vaso-motor reactions, stir to action the healthful emo-

tions which always accompany spontaneous activity, rid the body of the accumulated toxins generated by drudgery, and so recuperate and revitalize the body and mind. Play is an antidote to vice as well. Many a worker at narrow, circumscribed, and distasteful tasks may be saved from resort to alcohol, narcotics, drugs, and other harmful stimulants by being taught to find relaxation, diversion, and stimulation in proper physical play.

Many writers from Aristotle down have held that play furnishes catharsis of the emotions, purges both body and mind of detrimental impulses, normalizes, and sanifies. On the theory of catharsis certain strong instinctive tendencies, now no longer useful in their primitive form, require to be exercised in attenuated and modified ways until their period of nascency has passed and control of them has been attained. To illustrate, the pugnacious tendencies of boys find suitable exercise in football, boxing, and wrestling, instead of being allowed to run riot in quarrels and fights. If allowed proper opportunity to explore, collect, fish, swim, hunt, to care for and train pets, and the like, boys have less tendency to destroy or steal property, to torment animals, or commit other anti-social acts. The decided decrease in anti-social outbreaks, when ample opportunity for play is provided by public playgrounds, is one of the best arguments for the theory. Regular and suitable work, also, as Carr (10, p. 18) has shown, accomplishes the same ends. Idleness, vagrancy, and unsuitable employment are the sources of many harmful responses from which work and play may give catharsis. We shall be wise if we provide merely the opportunity for legitimate outlet for childish energy; we shall be still wiser when we plan to furnish suitable catharsis for the emotions and instincts and at the same time to turn this energy to positive and constructive ends.

• There is no denying that play does give preparatory exer-

cise and practice, as Groos holds, to many instincts and habits, and so prepares in a broad way for a useful, happy and normal life. Play is educative in far more effective and varied ways than most parents and teachers have yet recognized. It cultivates the senses, the powers of perception, observation, imagination, trains the judgment, increases by exercise the capacity for inventiveness, and trains the exploring, adventurous, creative powers of mind that are so favorable to the development of genius in industry and business.

Plays and games form character and mould the soul in varied and most effective ways. There is scarcely a virtue that is not born and reared to sturdy strength through suitable and timely play. Self-control, self-reliance, self-subordination, coöperation, loyalty, self-assertion, self-direction, capacity to lead and willingness to follow, are necessary virtues learned nowhere so readily and so surely. Justice, honesty, respect for the rights of others, the necessity for and the binding nature of law, and all those principles, recognition of which complex social and industrial life demands, come as by-products of rightly conducted play. Dramatization and imitation of adult activities give the best of insight into the duties and responsibilities of citizenship and train for them far better than mere instruction. Hall's *Story of a Sand Pile* is an excellent illustration of the varied and specific ways in which play under favorable conditions may prepare for citizenship by giving suitable practice to its essential activities.

Dewey (20), Miss Curtis (19), and many others have shown the way in which play socializes. Gregariousness is an inborn tendency, but the gregarious tendencies must have suitable exercise. Complete socialization is with children a slow process, as it was with the race. It does not come fully except by the freest exercise, which play best furnishes,

of that give-and-take experience which gives insight into the motives, desires, ideals, interests, and capacities of others as well as of one's self. The lack of complete socialization, which Bohannon has shown often characterizes the only child in a family, suggests how without the freest association with other children the social nature may be stunted. Imitative, dramatic, and traditional plays and games are especially important means of transmission from generation to generation of the vast and ever increasing social heritage.

The physical and hygienic values of play have been longest recognized. Growth itself, and still more the development of parts and organs, is furthered and normalized by suitable play. Ripening instincts furnish motive power through which motor responses are made again and again till coördinations are perfected, the muscles developed, and medullation of nerve fibers completed. Digestion, respiration, circulation — all the vital processes are stimulated to healthy activity under most favorable conditions. Physical endurance, resistance to fatigue, sex normality, strength and health are all direct results of a free and complete play life. Finally, we have begun to learn that body training is mind training; that exercise of muscles increases not merely the muscles, but the size, responsiveness, and capacity of nerve cells as well.

The play responses are peculiarly valuable further, as Carr (10, pp. 27-36) has shown, due to the following facts: (1) play reactions are easier than those of work, because they involve the oldest and oftenest used centers; (2) play brings a greater amount of activity because it is easier, more pleasurable, and less fatiguing than work; (3) the intensity of response is greater because attention is undivided and spontaneous, and therefore interest keener; (4) play is a better stimulant to growth and development than work, because it meets nature's demands in a natural and timely

way; (5) play is the most variable of all reactions, and thus provides constant and suitable exercise of all important physical and mental activities. For these and other reasons the child must play or he cannot become man. With Plato we can say, "education should begin with the right direction of children's sports."

QUESTIONS AND TOPICS

1. Is play an instinct? Give reasons for your answer.
2. State the theory of play in a way that is satisfactory to you.
3. Explain clearly the relations between play, work, and drudgery.
4. Observe carefully and make notes on the spontaneous play of the children in your neighborhood. Note age and sex differences; seasonal factors; cases of imitation and of leadership; persistence of particular plays; social elements; degree of interest, attention, and effort displayed.
5. Formulate a detailed characterization of the play life of children of some one period; e.g., the kindergarten age, or adolescence.
6. Make a careful study of some child who does not play normally. How does he differ in other ways from other children? How do you account for his lack of interest in play?
7. Make a survey of the play facilities in your immediate neighborhood. In what respects are they adequate and suitable, in what respects are they inadequate? Suggest improvements.
8. Do the same for the school in your neighborhood.
9. Enumerate the advantages resulting from the use of the play spirit in school work. Disadvantages.
10. Present arguments for and against the leadership of children's play by adults.
11. Explain how an activity calling for the expenditure of a tremendous amount of energy, to the point of exhaustion, may yet be properly called play. Illustrate.
12. Which is the better policy for the future, to increase the number of independent public playgrounds and the variety of their activities, or to increase the size, use, and organization of the school playgrounds under direction of the school authorities? Give reasons for your answer.

SELECTED BIBLIOGRAPHY

1. Archer, R. A. "Spontaneous Constructions and Primitive Activities of Children Analogous to those of Primitive Man"; in *Amer. Jour. Psy.*, vol. 21, pp. 114-50.

2. Addams, Jane. *The Spirit of Youth and the City Streets*. (1909.) Especially pp. 51-106.
3. Angell, E. *Play*. (1912.) 199 pp.
- *4. Appleton, L. E. *A Comparative Study of the Play Activities of Adult Savages and Civilized Children*. (1910.) 94 pp. (Bibliography.)
5. Blow, Susan E. *Symbolic Education* (1894), pp. 111-45.
6. Bolton, H. C. *Counting-Out Rhymes of Children*. (1888.) 121 pp.
7. Burk, Mrs. C. F. "The Collecting Instinct"; in *Ped. Sem.*, vol. 7, pp. 179-207.
8. Burnham, W. H. "The Hygiene of Physical Training"; in *Amer. Phys. Educ. Rev.*, vol. 14, pp. 468-78; 521-28; 600-08.
9. Cabot, R. C. "The Soul of Play"; in *The Playground*, vol. 4, pp. 285-93.
10. Carr, H. A. "The Survival Values of Play"; in *Invest. of the Dept. of Psy. of the Univ. of Colo.*, vol. 1, pp. 1-47.
11. Chamberlain, A. F. *The Child* (1900), pp. 10-27.
12. Chambers, W. G. "Why Children Play"; in *Proc. N.E.A.* (1909), pp. 720-26.
13. Chase, J. H. "Street Games of New York Children"; in *Ped. Sem.*, vol. 12, pp. 503-04.
14. Claparède, Ed. *Experimental Pedagogy and the Psychology of the Child* (1911), pp. 102-38.
15. Compayré, G. *Intellectual and Moral Development of the Child. Part II, Later Infancy* (1902), pp. 141-52.
- *16. Crosswell, T. R. "Amusements of Two Thousand Worcester School Children"; in *Ped. Sem.*, vol. 6, pp. 314-71.
- *17. Curtis, H. S. *Education Through Play*. (1915.) 359 pp.
- *18. Curtis, H. S. *Play and Recreation for the Open Country*. (1914.) 265 pp.
- *19. Curtis, Miss E. W. *The Dramatic Instinct in Education*. (1914.) 246 pp.
20. Dewey, J. "Play"; in *Monroe's Cyclo. of Educ.*, 1912, vol. 4, pp. 725-27.
21. Eastman, C. *Indian Boyhood* (1911), pp. 63-98.
22. Folsom, J. K. "The Scientific Play World of a Child"; in *Ped. Sem.*, vol. 22, pp. 161-82.
- *23. Forbush, W. B. *Manual of Play*. (1914.) 353 pp.
24. Gillin, J. L. "The Sociology of Recreation"; in *Am. Jour. of Sociol.*, vol. 19, pp. 825-34.
25. Gomme, Alice B. *Dictionary of British Folk-Lore. Part I, vols. 1 and 2* Especially vol. 2, pp. 458-531. (1898.)
- *26. Groos, K. *The Play of Animals*. (1898.) 341 pp.
- *27. Groos, K. *The Play of Man*. (1901.) 412 pp.
28. Guillet, C. "Recapitulation and Education"; in *Ped. Sem.*, vol. 7, pp. 397-445.

29. Gulick, L. "Psychological, Pedagogical, and Religious Aspects of Group Games"; in *Ped. Sem.*, vol. 6, pp. 135-51.
30. Hall, G. S. *Adolescence*. (1904.) Especially vol. 1, pp. 129-236; vol. 2, pp. 202-36.
31. Hall, G. S. *Youth* (1906), pp. 73-119.
- *32. Hall, G. S., and pupils. *Aspects of Child Life and Education*. (1907.) 326 pp. Especially, "The Story of a Sand Pile," Hall; "A Study of Dolls," Hall and Ellis; "The Collecting Instinct," Burk; "Fetichism in Children," Ellis.
33. Hall, G. S. *Educational Problems*. (1911.) Vol. 1, chap. v, "The Educational Value of Dancing and Pantomime," pp. 42-90.
34. Hall, G. S. "Recreation and Reversion"; in *Ped. Sem.*, vol. 22, pp. 510-20.
35. Henderson, E. N. *Principles of Education* (1910), pp. 283-426.
- *36. Johnson, G. E. "Education by Plays and Games"; in *Ped. Sem.*, vol. 3, pp. 97-135.
37. Johnson, G. E. *Education by Plays and Games*. (1907.) 234 pp. (Bibliography.)
38. Johnson, J. "Rudimentary Society among Boys"; in *Johns Hopkins Univ. Studies in Hist. and Pol. Sci.*, vol. 2, pp. 495-546.
39. Kidd, D. *Savage Childhood* (1906), pp. 159-84; 301-04.
40. Lee, J. *Play in Education*. (1915.) 500 pp.
41. Major, D. R. *First Steps in Mental Growth* (1906), pp. 239-49; 352-55.
42. Mangold, G. B. *Problems of Child Welfare* (1914), pp. 166-88.
43. McDougall, W. *Social Psychology* (1912), pp. 107-16; 345-46.
- *44. McGhee, Z. "A Study in the Play Life of Some South Carolina Children"; in *Ped. Sem.*, vol. 7, pp. 459-78.
45. Newell, W. W. *The Games and Songs of American Children* (1903), pp. 1-36.
46. O'Shea, M. V. *Social Development and Education* (1909), pp. 295-320.
47. Parmelee, M. *The Science of Human Behavior* (1913), pp. 245-55.
48. Patrick, G. T. W. "The Psychology of Play"; in *Ped. Sem.*, vol. 21, pp. 469-84.
- *49. Patrick, G. T. W. *The Psychology of Relaxation*. (1916.) Especially pp. 29-95. (Bibliography.)
50. Pyle, W. H. *The Outlines of Educational Psychology* (1912), pp. 91-107.
51. Seashore, C. E. *Psychology in Daily Life* (1914), pp. 1-37.
52. Sheldon, H. D. "Institutional Activities of American Children"; in *Am. Jour. Psy.*, vol. 9, pp. 425-48.
53. Sisson, Miss G. "Children's Plays" in Barnes's *Studies in Education* (1897), vol. 1, pp. 171-74.
54. Smith, P. A. "Some Phases of the Play of Japanese Boys and Men"; in *Ped. Sem.*, vol. 16, pp. 256-67.

55. Sully, J. *Studies in Childhood* (1895), pp. 35-51.
56. Swift, E. J. *Youth and the Race* (1912), pp. 3-40.
57. Tanner, Miss A. *The Child* (1915), pp. 487-512. (Bibliography.)
58. Thomas, W. I. "The Gaming Instinct"; in *Am. Jour. Sociol.*, vol. 6, pp. 750-63.
59. Thorndike, E. L. *Educational Psychology; Briefer Course* (1914), pp. 59-68.
60. Wood, W. *Children's Play and its Place in Education*. (1913.) 219 pp.
61. *The Playground*. Official organ of The Playground and Recreation Association of America, 1 Madison Avenue, New York.

CHAPTER VII

THE LINGUISTIC DEVELOPMENT OF CHILDREN

Definition. In a broad sense the term *language* includes every means by which thought is symbolized so as to convey meaning or serve the purposes of communication. When we wish to designate that specialized form of language in which the articulate sounds we call words are used, it is better to employ the term *speech*. We shall, then, include under the term language such means of communication as signs, gestures, facial expressions, attitudes, pantomime, exclamatory emotional sounds, articulate speech by means of words, and such other forms of expression as writing, drawing, painting, modeling, carving, building, and the like, whenever these are used to convey ideas, meanings, emotions, or to arouse responses in others.

Language, in the sense in which we use the term, is possessed by many animals besides man. The ants are thought to communicate by means of their antennæ; birds by means of cries and calls; dogs by a variety of cries, whines, attitudes, pantomime, and even facial expression; monkeys and apes, according to Mr. Garner (12, p. 258), who has studied the subject most closely, by similar means and, in addition, among the highest species, by articulate sounds and "words" to the number of twenty-five or thirty. But, in spite of the fact that an elemental form of language is possessed by all the higher animals, the capacity for speech separates humanity from other forms of animal life by a greater gap than does any other capacity. We must admit the kinship of humanity with other forms of life, we can find fruitful suggestions as to the origin of speech in our race in the study of

animal language, we may frankly admit that Mr. Garner's apes possess greater power of speech than the average human infant of one year of age, and yet feel perfectly safe in our belief that the invention of articulate speech and the perfecting of its use is the greatest single intellectual accomplishment of the human race, and marks most clearly its superiority over every species of animal. This invention, and the much later one of written and printed symbols for its graphic embodiment, have separated humanity from other living forms by what appears to be an impassable barrier.

Articulate and written speech are rated so high because by their use we are largely freed from the narrow, circumscribed, limited means of expression possessed by other animals. By their use we largely annihilate time and space. By their use we have opened to us the practically infinite possibilities of symbolization of ideas and images. By their use we can deal with the abstract as well as the concrete, so that the mind is not only freed from limitations, but is enlarged and developed in the process of speaking.

Theories of origin. Extended discussion of the theories of the origin of language would be out of place here. Those who care for a full statement of the theories will find good summaries in Chamberlain (4, pp. 113 ff.) and Judd (20, pp. 248 ff.). No theory has yet been proposed which is wholly satisfactory. When we get such a one it is likely to be psychological and evolutionary. Psychologists and philologists have long recognized that the similarity between speech development in the child and the race makes it probable that a study of child language is the best means now available for the settling of the difficult problem of origins. This conviction has been the stimulus of much of the recent careful study of the evolution of child language.

- The onomatopœic origin of many words with both the

race and the child cannot be denied, and yet the theory that speech arose wholly from this tendency cannot be admitted. Interjections, made peculiarly expressive by varying intonations, are a marked feature of both primitive and child speech, and yet to hold that all speech so originated is unquestionably a partial and narrow view. Following the contention of Henri, that the problem of the origin of speech is perhaps as much a matter of anatomy and physiology as it is a linguistic one, Lefève finds the origin of speech in the differentiation of instinctive cries. As quoted by Chamberlain (4, p. 119) he says: —

Animals possess two of the important elements of language — the spontaneous reflex cry of emotion or need, the voluntary cry of warning, threat, or summons. From these two sorts of utterance, man, endowed already with a richer vocal apparatus and a more developed brain, evolved numerous varieties by means of stress, reduplication, intonation. The warning or summoning cry, the germ of the demonstrative roots, is the parent of the names of numbers, sex and distance; the emotional cry, of which our simple interjections are but the relics, in combination with the demonstratives, prepares the outlines of the sentence, and already represents the verb and the names of states or actions. Imitation, direct or symbolical, and necessarily only approximative of the sounds of external nature, i.e., onomatopœia, furnished the elements of the attributive roots, from which arise the names of objects, special verbs, and their derivatives. Analogy and metaphor complete the vocabulary, applying to the objects discerned by touch, sight, smell, and taste qualifying adjectives derived from onomatopœia. Reason then coming into play rejects the greater part of this unmanageable wealth, and adopts a certain number of sounds which have already been reduced to a vague and generic sense; and by derivation, composition, and affixes, the root sounds produce those endless families of words, related to each other in every degree of kindred, from the closest to the most doubtful, which grammar finally arranges in the categories known as the parts of speech.

Interesting and suggestive as are all these theories, there are unquestionably other factors in speech development

which future theories must consider. That the speech development of both child and race has well-marked evolutionary stages all studies seem clearly to show. In all probability speech and ideational processes developed together in the race as now they do in the infant. Imitation helps to a rapid acquirement of the social inheritance, but true speech develops only as mentality enlarges, in fact its mastery is one of the surest indications of intelligence.

Ontogenesis of speech. The most interesting phase of linguistic study is that which concerns itself with the acquirement of speech by the child. The number of careful studies in this field has multiplied very rapidly in recent years, and some facts regarding this phase of development have already become pretty well established. It is our purpose in this section to give a brief résumé of these studies and the more important conclusions which can be drawn from them.

Tracy (46) long ago pointed out that the capacity for speech is dependent upon physiological and psychological factors, the absence of either of which makes speech impossible. In the first place, the child must possess the speech mechanism, made up of the lungs and air passages, the larynx, tongue, teeth, palate, oral and nasal cavities, the three groups of muscles producing respectively the movements of respiration, vocalization, and articulation, and finally the nerve elements, both central and peripheral, which integrate and preside over the activity of the whole mechanism. This complex neuro-physiological mechanism must not only be present but must be in fairly normal condition in all its parts, functionally mature enough to operate as a unit, and most important of all it must be to some degree under control before real speech can be begun. By real speech we mean the conscious use of words as the symbols of ideas. On the psychic side there must be emotions, ideas, experiences seeking expression, and a large amount of spon-

taneous, playful exercise of the speech mechanism before it can be controlled or used for purposes of voluntary speech. So, as Tracy (46) suggests, to the interesting question, "Why does the newborn child not speak?" we may reply that he has no ideas and few emotions calling for expression, and that if he had he would be unable to express them in speech because of the imperfection of his speech mechanism and the lack of control over it. In short, he has nothing to say and could not say it if he had. The teeth, so important to enunciation especially of the dental consonants, are entirely lacking; breathing is purely automatic, and diaphragmatic rather than costal; phonation is reflex and involuntary or non-voluntary at first. The size, shape, and relation of the parts of the larynx, throat, and the oral and nasal cavities are very different from those of the adult, so that exact imitation is out of the question. The action of the three groups of muscles controlling the speech mechanism is at first entirely involuntary, those of phonation especially never becoming wholly voluntary. The ear, without the help of which true speech is not normally acquired, only attains its directive capacity after months of schooling. Imitation, which is the basal capacity so far as acquirement of the social heritage of speech is concerned, does not play an important part for months. These and other like facts which any one may easily observe should give us some conception of the difficulties which children surmount in their mastery of speech. Knowledge of the difficulties to be encountered should enable the parent and teacher to remove to some extent many unnecessary obstacles.

Heredity and speech. The ability to acquire speech is an inborn capacity, the attainment of which depends upon many factors in the child's environment. We cannot call speech an instinct if we use the term in a properly restricted sense. Children are never born with a form of speech, but

merely with the physical mechanism and the psychic potentialities which enable them to acquire speech under the stimulus of the instincts of physical and mental activity, the impulse to play and to imitate, and under the spur of necessities bound up closely with the gregarious instinct. The Chinese infant, with thousands of years of pure Chinese ancestry back of him, acquires, if reared from the day of his birth in an English-speaking family, the English speech with no more difficulty than he would his parents' tongue. The child born deaf does not learn to speak except with the greatest difficulty and after the most careful training, although he acquires the more primitive forms of linguistic expression without other help than that afforded by examples which he can imitate. Speech must not, then, be thought of as an instinct, but as a habit with a strong instinctive basis.

First steps in speaking. Miss Shinn (39) points out that the first three words of her niece were some months in process of evolution before they came to be real words expressive of "a natural cry of pointing out" — "Dǎ!" the protean forerunner of our "There!"; "a natural negative" — "Nǎ-nǎ-nǎ!" later to merge into our "No!"; and "a natural expression of baby need and dependence" — "Mǎ-mǎ-mǎ," or, "*Mom-mom-mom*," gradually associating itself with the baby's mother as the satisfier of wants, and after some teaching settled into the word which possesses the richest of all associations — the word "Mamma" or "Mother." Thus babble and chatter of the pre-linguistic period gradually turned to special uses and the child began its first steps in speech. Even in these first steps it seems clear that Miss Shinn's contention, that the first words are exclamations for the relief of the child's mind much more than they are means of communication, has much in its favor. Her fourth word, after many variations, settled into "*Góng*" meaning

disappearance, absence, failure, etc. The fifth word of this child, — “*Kha*,” — an expression of disgust, was learned by imitation directly, as is most of the later vocabulary, if exceptions be made of some “invented” words. These five words made up the entire vocabulary of the first year of the heroine of *The Biography of a Baby*. Thus Miss Shinn thinks the baby begins “slowly to turn some of his commonest chattering sounds to special uses — not to carry thought to other people, but as mere exclamations to relieve his own mind.” Miss Shinn’s description is typical of the first steps in mastery of speech with every child.

Linguistic stages. Many psychologists have attempted to name and describe definite stages in the development of speech. While there are minor differences in details there is practical agreement upon the more important stages. All of the more or less elaborate classifications present at least the following stages which we adapt from many published studies: (1) A reflex period of involuntary preliminary exercise of the speech mechanism seen in cries, gestures, and articulate babble which is in no true sense consciously expressive, still less communicative; (2) a period of developing understanding of articulate sounds, marked toward its close by imitative and playful babble of a spontaneous sort; (3) a period of development of facility in thought expression by means of words. It is not difficult to recognize well-marked subdivisions of each of these stages. One of the most useful and suggestive statements of the speech stages is that of Pelsma (61), to whom we are indebted for the names and descriptions which are now to be given.

(1) *Reflex*. A short stage in which undifferentiated cries, gestures, “coos,” and the like are made spontaneously, without recognition of their expressive or communicative value. The actual differentiation of the primitive “*ă*” cry of the infant has by most observers been found to take place between the third and the fifth weeks.

(2) *Cry and gesture stage.* With the advent of the infant's first true smile, which is usually noted sometime near the third month, his awareness of his environment, especially of the world of people, is clearly evidenced. This much-looked-for event has been thought to signalize a new attitude, and to mark the beginning of at least crudely purposeful use of the primitive means of expressing thought and emotion — cries, gestures, facial expression, and the like.

(3) *Babbling.* When definite, purposeful reactions to his environing world begin, the part played by vocalization in such responses rapidly assumes an important place. The first step toward true speech is taken when vocal responses are made to the vocal stimulus of the mother's voice. Of first importance, therefore, in the preparation for true speech is the period of playful exercise of the speech mechanism, commonly known as the period of linguistic play or the babble period. From purely spontaneous babble the infant soon passes to imitative babble, learning rapidly meanwhile the communicative value of sounds and perfecting his control of his speech mechanism.

(4) *Imitation.* Beginning in purely mechanical, imitative babble, and passing rapidly to conscious learning of spoken words, this stage is the keystone of the arch of the linguistic structure, one side of which is based on physical and mental inheritance, the other on social heredity.

(5) *Plateau.* A transition period which many observers have found to be a feature of learning curves in general seems usually to be found also in the mastery of speech. The rate of progress is retarded, or may even decline, but a perfecting and settling of what has already been acquired seems to take place. Since this stage is as a rule coincident with the acquirement of creeping and walking it is reasonable to assume that the child's attention and energy is turned into these other channels to the temporary loss of

progress in speech. These activities, however, so enrich experience and mental content as to be very significant as stimuli to later progress.

(6) *Expression.* True speech has begun when, with a consciousness of the meaning and value of words, the child begins purposively to use them to express or to communicate his thoughts and feelings. When this point is reached all the rest of his immature years are devoted to the perfecting of this power. A few of the significant facts concerning the mastery of the mother tongue will be discussed in the following pages.

The age limits to be assigned to the various speech stages are not easily determined because of individual differences, and the fact that each as a rule merges into the succeeding stage gradually and almost imperceptibly. It is perhaps sufficient to say that the first stage begins as soon as the child is born; that the second appears in a few days or weeks at most; that the third is at its height from six to eight months usually; that the fourth begins during the third period and becomes a factor of increasing importance, really overlapping all succeeding stages; that the fifth is reached sometime between nine and eighteen months, varying with the time of walking, and that the sixth normally begins early in the second year and has reached a well-developed state by the beginning of the third year. Certain other suggested periods we shall now briefly consider.

Secret languages. There have been noted within the stage of expression several rather well-marked periods, such as those of "secret language," and of "slanguage." From an extended study of five hundred "secret languages" of children, Dr. Chrisman (7) finds, in addition to the "invention" of many words at or shortly after the time the child has well begun the learning of the mother tongue, a distinct "secret language" period. The invention or use, or both, of secret

languages seems to be well-nigh universal between the ages of eight and fifteen, with especial prominence between ten and thirteen years. Many of these "languages" are passed down from generation to generation of children. Some are originated by small groups, and in a few instances have been known almost to crowd out the use of the mother tongue for a time. Many of these attempts at linguistic creation are crude, artificial, and nonsensical perversions of the mother tongue. On the other hand, Hale (5, p. 137) found some which possess all the characteristics of real, live, growing languages. This trait of children has been considered to have theoretical importance as suggesting a means of explaining the origin of dialects and new linguistic stocks. For our purpose perhaps the most important deduction is the contention of Chrisman, that, next to the period at which children acquire naturally their mother tongue, the "secret language" period is most favorable for the acquirement of a foreign language. The plasticity of the speech function in both its physiological and psychic sides, coupled with the strong innate interest in that which is strange, new, or different, gives a most favorable opportunity to the teacher of a foreign tongue.

Slang. The tendency to "invention" has also its undesirable phases. Whether it be the "baby talk" of infancy and early childhood, the "hog-Latin" or "pidgin-English" of the secret language period, the lover's lingo of later adolescence, or the use of slang which in some circles, as among sailors, criminals, and at certain ages among all classes, results in the mother tongue being almost superseded by what has been termed "slanguage," there is serious danger that the mastery of the mother tongue will be definitely retarded if not permanently affected. It has even been suggested that mental growth and the development of intelligence may be thus impaired. Conradi (9), Secrist (37), Melville (26), and

others find the slang period, if such there is, to attain its high point at about the beginning of the onset of puberty. It is believed that the wonderfully rapid expansion of intellectual and emotional life at this time, which outruns the power of expression, creates the natural demand for new, striking, unusual, and more expressive terms than the conventional ones, and a craze for slang is the result. If this be true there should be no more favorable time for the use of every good teaching device to enrich, refine, and enlarge the child's vocabulary. Language teaching at this period should have this object as one of its chief aims.

Vocabularies of children. The studies that have thrown most light on child language are those of the acquisition of vocabulary. In 1907 Doran (56) summarized thirty-six such studies. In 1910 Pelsma (61) reports on seventy-two, and Grant (57) in 1915, tabulates the results of a total of eighty-five. New studies are appearing frequently, so that the number is likely soon to exceed one hundred. The investigations are becoming more valuable because of refinement of method and attack on new problems. The years covered by the published vocabulary studies range chiefly between one and five, with the greater number in the earlier years. In a number of cases estimates have been made of the vocabulary of the same child at several different periods. Very few attempts to make accurate estimates of the vocabularies of children of school age are on record.

It is too early to draw many trustworthy generalizations from these studies, for several reasons. The number is, as yet, too small. The methods by which they have been made are too diverse. The underlying purpose of the studies has also varied considerably, so that the observer's report has been affected in such a way as to make his material difficult to compare with that of others. In spite of necessary caution and scientific reserve, however, a number of tentative con-

clusions may be stated, particularly for the first three years. We must content ourselves for the present with a statement of the generally accepted methods for such work, a brief summary of the concrete data, the statement of a few tentative generalizations, and a few suggestions as to the value parents and teachers may expect to find in such studies as have been made or of such as they may make for themselves.

Methods of study. The recorded vocabularies of children have been secured by the use of one or all of the following procedures: The observer usually prepares a notebook with a page for each letter of the alphabet, subdividing the pages into spaces for the various parts of speech according to their known frequency. The observer then plans to be with the child constantly during his waking hours, or to have a qualified substitute to take his place, for a period of at least two or three weeks near the child's birthday, or at the mid-year period. This length of time allows the observer to place the child in a variety of situations so that the different environments may, by presenting varied stimuli and evoking varied interests and emotions, call forth the fullest spontaneous use of the speech capacity. If care and discretion are used, it seems fairly certain that for the early years one may, in a few weeks, secure practically complete lists of the words which the child can use with at least a fair conception of their meaning. It should be said that great care is needed to avoid the listing of words used in a mechanically imitative way, without any idea of their meaning. Carelessness in this matter may result in unjustified padding of the vocabulary list.

After the preliminary preparation, most of the observers follow the plan outlined by Pelsma (61), making record without delay of: (1) words used with evident conception of their meaning in daily conversations between the child and the observer, or other persons; (2) words used in re-

sponse to questions carefully formulated, so as not to give the word or words knowledge of which is being tested; for example, such questions as, "What is this?" "What is papa doing?" and the like; (3) words used when objects or activities are brought to the child's attention without questions, in such ways as to cause him to name them or speak about them; (4) words used in spontaneous monologue or in conversations with other children, real or imaginary, when the child is oblivious to the presence of the observer. Some observers list at later periods words that were used at an earlier one, and some make systematic use of previously published vocabularies of other children asking questions or presenting situations to determine the knowledge or ignorance, of the child under observation, of the words in question. It should be noted that the procedures followed, the time taken for the study, and possibly other factors will affect the results, and yet it is doubtful whether any of the observers of children past two years of age secure entirely complete lists. It is also unquestionably true that the vocabulary understood by the child is much larger than his spoken vocabulary. Exact summaries of the existing lists are probably somewhat inaccurate and in some respects misleading. If, however, the reader will bear in mind that averages are of little value where numbers are small, and that in a field such as this the matter of individual differences, with the probable reasons for them, is of greater interest and importance than averages, we may venture to indicate what the published studies show. In using the accompanying table it must be further understood that some observers exclude proper nouns, while others include them; that some list verb forms only once, while others list infinitive and participial forms as separate words; that some include "invented" words, while others exclude them. For these and other reasons more value attaches to careful examination of one or

TABLE I
AVERAGE VOCABULARIES AT DIFFERENT AGES

Age	No. of cases	Ave. no. of words	Extremes	
			Least	Greatest
1 year	10	8.9	3	24
2 years	20	528	115	1127
3 years	8	1407	681	2282
4 years	6	2171	1020	3915
5 years	1	6837		
6 years	1	3950		

two individual vocabularies in detail than to the study of averages now available.

Use of parts of speech. One of the much-discussed points about vocabularies is that of the relative number of the various parts of speech found in the vocabulary as a whole and as actually used, and especially the changes that take place with age. Estimates differ widely, for various reasons. In early speech there is almost total disregard of grammatical form and usage. The first words are as a rule "sentence words," as Sully (41, p. 171), Lukens (22), and others have clearly shown. A single word conveys a variety of meanings, depending upon intonation, inflection, accompanying gestures, facial expression, pantomime, and similar factors. The pronoun "me" often performs the function of such sentences as "Take me up," "I want to ride," "Give me the book," "Let me go with you"; the preposition "up" may mean at one time, "I want you to give me my ball," or again, "I want you to put me up in my chair." Lukens (22)

cites many examples of functional misuse of parts of speech, of which the following are typical: "It *ups* out its false feet" (said of an amoeba seen under the microscope); "a *chop*" (axe); "the hurt *blooded*"; "Can I be *sorried*?" (i.e., forgiven); "What is the reason you want to *dead* that fly?" — "to die that fly?" — "to make it dead?" (22, p. 454). Thus nouns play the part of verbs and, *vice versa*, adjectives play a verbal function, etc. For these and other reasons classification of the child's words under the conventional parts of speech is usually more or less misleading. Keeping the facts just mentioned in mind, the accompanying tables may still have some value.

TABLE II
PARTS OF SPEECH IN CHILD VOCABULARIES
(Expressed in percentages)

Cases	Age	Total Ave. vocabulary	Nouns	Verbs	Adj.	Adv.	Pro.	Prep.	Conj.	Int.
10.....	1	88	65.3	6.9	5.1	12.8	0	0	0	9.8
20.....	2	528	58.9	20.8	9.79	4.88	1.9	1.44	.21	1.87
8.....	3	1407	55.59	23.1	10.8	5.1	2.2	1.4	.6	.9
6.....	4	2171	53.6	25.	12.	5.1	1.45	1.	.66	.9
1.....	5	6837	56.8	19.3	21.8		2.17			
1.....	6	3950	48.	24.	10.	3.4	.9	.6	.2	.5

We have found forty-six vocabulary studies in which the distribution of the parts of speech has been indicated. Our table is a summary of the facts. Examination of the averages shows that interjectional speech is characteristic at the beginning; that nouns are acquired early in relatively large numbers; that from the first year on the ver-

bal element is relatively very large, the relative proportion of adverbs to adjectives being also greater than later; that personal pronouns, relative pronouns, and other subordinating and connective words are acquired with difficulty, but, owing to the relatively restricted vocabulary of children, still occupy a proportionately larger place than in the language, as Table III shows, if we accept the estimate of Kirkpatrick. A recent estimate by Brandenburg (53) shows a much closer resemblance between child vocabularies and the dictionary, especially as regards the supposed preponderance of verbal elements with children.

TABLE III
ESTIMATES OF PARTS OF SPEECH IN THE DICTIONARY
(Expressed in percentages)

<i>Authority</i>	<i>Nouns</i>	<i>Verbs</i>	<i>Adj.</i>	<i>Adv.</i>	<i>Prep.</i>	<i>Pro.</i>	<i>Conj.</i>	<i>Int.</i>
Kirkpatrick	60.	11.	22.	5.5	1.5			
Brandenburg	48.4	27.5	18.6	4.9	.1	.2	.1	.05
Wolff's boy's dictionary	42.	30.	8.	10.	4.	6.		

The report by Miss Wolff (49) of a dictionary made spontaneously by a boy of seven shows an excessive interest in words that "clearly express definite action," seventy-five per cent of the 215 words attempted belonging to this class.

Several writers have shown that far more significant than the percentage of nouns, verbs, adjectives, etc., in the child's whole vocabulary is the percentage of each that he actually uses in connected speech. Mrs. Moore (29, p. 136) found that of 661 words used in one series of sentences, 43.4

per cent were nouns or pronouns, 24.8 per cent verbs, 9.5 per cent adverbs, 7.4 per cent adjectives, 3.7 per cent prepositions, 11.8 per cent indefinite articles, with a few interjections and an occasional conjunction. She concludes (p. 137) "that the percentage of words of a class contained in the vocabulary is but an indifferent index of the frequency with which representatives of the class are brought into active service." In the early part of her child's second year, 33.8 per cent of the sentences had no verb; at the end of the year, only 7.2 per cent. Boyd (52) made estimates of the percentage of each part of speech used by his child in actual sentences at two, three, and four years, with much the same results as the accompanying table shows. Commenting on the results, Boyd (52, p. 117) says, "a very striking feature is the sharp fall from the second to the third year in the percentage of nouns, verbs, adjectives, and adverbs, and the related rise in the percentage of pronouns, adjectives other than qualitative, auxiliaries, conjunctions, and prepositions." The difference is obviously connected with the profound changes which take place in the course of the third year in the organization of speech.

TABLE IV
PARTS OF SPEECH AS ACTUALLY USED

<i>Observer</i>	<i>Age</i>	<i>Nouns (and pro.)</i>	<i>Verbs</i>	<i>Adv.</i>	<i>Adj.</i>	<i>Pro.</i>	<i>Prep.</i>	<i>Conj.</i>	<i>Int.</i>
Moore.....		43.4	24.8	9.5	7.4	..	3.7	few	few
Boyd.....	2	36.8	28.4	13.2	13.7	6.2	1.2	.2	.3
Boyd.....	3	16.4	31.9	9.4	17.4	15.8	5.6	3.4	.2
Boyd.....	4	14.8	31.9	11.6	14.6	18.1	5.7	2.9	.3

The importance of such studies lies in the indications they give of the linguistic difficulties and needs at certain periods. The studies are too few as yet, and especially too little comparison has been made of the actual working use of speech by children at different ages and that of adults, to warrant any very definite suggestions. It seems certain at least that such studies should be of great value in determining where to put the stress, at various stages, in the functional teaching of grammatical usage.

Definitions and word meanings. Binet (1890) was perhaps the first to call attention to the preponderance of the factor of *use* in definitions given by children. He was followed by Shaw, Barnes, and others. The Barnes (3) study of two thousand children, fifty boys and fifty girls of each age from six to fifteen years, shows use standing first at 45.38 per cent for all ages, with a steady decline from 79.49 per cent at six to 30.62 per cent at fifteen years. Typical definitions in early years are such as, "An orange is to eat"; "a table is to eat off"; "a stove is to put fire in"; "a spoon is to eat in"; "a river means where you get drinks out of, water, and catch fish, and throw stones in." The last phrase illustrates well the dynamic nature of many definitions, as do most of the definitions by use, as well as such as the following one from "A Boy's Dictionary": "Saw is if you see something, after you see it you saw it."

Chamberlain's child (5, vol. 16, pp. 64-103) showed in her definitions "the rapidity of the thoughts of children and the subordination of grammatical form to their immediate expression." For example: "*Tight*. This is too tight your dress. When I sit down, that dress you just took off why, it pulls my neck." Her primitive tendency to give "graphic descriptions or pictures" is illustrated in defining *snowy*: "When it's snowy under the bamboo-tree and on the leaves is bunches of snow. Ah! here the leaves come out to

play." Other definitions are brief phrases, as *gingham* — "cloth," or, "to wear," etc.; actions without words at all; definitions accompanied by actions; as, "*Baby*. It means babies that creep, — just like this" (she illustrates by creeping); words accompanied by pointing out, touching, saying *this* while pointing, acting out, etc. Many definitions contain such words as *when, where, for, because, what, that, why, if, just*, etc. In some onomatopœia appears, in some linguistic invention, some are quite satisfactory, and in some analysis, analogy, comparison, etc., appear, but these last are the exception till mature years.

The mastery of speech is by no means complete when a vocabulary of goodly proportions has been acquired. One of the most important phases in mastery of speech is the enrichment and perfecting of meaning or content of words. Hall, and later Barnes (2) and Chambers (6) made a very important contribution to language teachers by revealing clearly that children, and, to only a lesser degree, all persons, use many words with incorrect, incomplete, partial, or almost total lack of content. Even such a common word as *school* was found to have correct content with only forty per cent of children at six, and with ninety-two per cent at twelve years. The more uncommon word — *monk* — was entirely devoid of content at six, and had attained correct content for only eighteen per cent at twelve years, if we may judge by their ability to define the terms as determined by Chambers (6).

It seems very certain that in view of such facts it is much more important to perfect and enrich the content of a child's vocabulary than merely to add new words to the number already known. Since words are the symbols of ideas, the way to such enrichment lies in providing the child with ample opportunity to experience richly, to think freely, and to use his speech capacity to the full in expression of his

own best thoughts and feelings to sympathetic auditors. It does not flatter our vanity to have to admit that our schools furnish too little opportunity along all these lines, and that we too often accept "words, words, words," and too rarely attempt to tease out the ideas, if such there be, whose presence or absence words all too easily disguise, because words are often, after all, a crude tool or a good tool clumsily used.

Several recent studies have shown that environment very directly affects the growth of vocabulary, and especially word content. Mrs. Nice (60) believes that the richness of the child's outdoor experience is reflected definitely in its speech. She cites as evidence her daughter's vocabulary at three periods, with notes on the environment, and comparisons with other children's vocabularies showing how the child's experience and environment are reflected in his speech. Derver (11) emphasizes the fact that "expansion of a child's environment always tends to increase *nouns* relatively to other parts of speech." Both find, as others have, that number, time, space, and color vocabularies are undeveloped at four years, and are more dependent upon mental development than environment. Richness of experience, however, does help progress in mastery of these abstract terms, as it also promotes intellectual maturity, of which abstract concepts are an evidence.

Use of the sentence. Mastery of the various sentence forms is a matter of much difficulty. It involves, as Major (302) shows, the learning among other things of: (1) the function of the parts of speech, especially connective and subordinating words — pronouns, conjunctions, prepositions; (2) the proper number of words; (3) conventional word order; (4) intricacies of inflection; (5) use of the negative; (6) formulæ for questions; and (7) refinements of word content. The most serious limitations at first are the restricted vocabulary and the desire for directness in

speech, which makes the child strike vigorously at the point or idea that he wishes to express, regardless of conventional requirements. To a child of two or three years of age, as Lukens observes (22, p. 459), "the order of words is nothing. He wants to say it all at once." Word order varies so in different languages that it would seem that this is more a matter of tradition, habit, and custom than of logic. The child therefore acquires the traditional usages slowly and with difficulty. The child's sentences are short and usually simple. Mrs. Moore (29, p. 136) found that the average number of words in several hundred sentences used by her boy was 3.02 in the early part of the second year, and 4.05 in the latter part of the same year. Brandenburg (53, p. 94) found the average number of words, in 1487 sentences, of his three-year-old child to be 6.6. Miss Snyder (40, p. 412) found a large proportion of the sentences of a two-and-a-half-year-old child to be imperatives, or simple variations of the imperative. Many sentences that were declarative in form were really imperative in function. There was comparatively little interest in or use of complex or compound sentences.

Linguistic activity of one day. Some interesting light is thrown upon the value and significance of speech in the daily life of children by several studies which have, by actual count, determined the extent of its use in a single day. Eight such estimates are summarized in the accompanying table, an examination of which must make it evident that the speech function is a very vital one in infancy. Children of the pre-school period talk most of the time they are awake. Brandenburg's child used 950 words per hour, and during the day uttered 1487 sentences, exclusive of repetitions, each sentence containing on the average from five to seven words. At these years it seems that children have few unused words in their vocabularies, for a large percentage of the entire

TABLE V
LINGUISTIC ACTIVITY FOR A SINGLE DAY

<i>Observer</i>	<i>Age</i>	<i>Child's vocabulary</i>	<i>Different words used</i>	<i>Total words used</i>	<i>Per cent voc. used</i>
Gale.....	2	729	635	5194	87
Gale.....	2	741	396	4275	53.4
Gale.....	2	(Est. 1400)	805	10507	...
Gale.....	2½	1432	751	9290	52.5
Gale.....	2½	1509	629	8992	41.6
Brandenburg.....	3	2282	859	11623	37.6
Bell.....	3½	15230	...
Bell.....	3½	14996	...

vocabulary is used every day, the percentage decreasing as the vocabulary increases. The impulse to utter aloud every thought that comes into the mind unquestionably plays no small part in the progress which the child makes in the mastery of speech. To inhibit this tendency overmuch at this period, or to fail to allow ample opportunity for oral speech during the early school years, certainly tends to repress and perhaps to retard the very developments we wish to further in our teaching of the mother tongue.

Speech and intelligence. Retardation of speech development has long been considered an evidence of mental retardation. Recently numerous careful studies of this relationship have confirmed this belief and made it more definite. Mead (25) found, in comparing twenty-five normal boys and twenty-five normal girls averaging less than six years of age with fifty-six boys and thirty-six girls of the schoolable class of feeble-minded children, that there are signifi-

cant differences in the age at which talking is begun, as the accompanying table from his study shows.

TABLE VI
AGE OF BEGINNING TO TALK
(After Mead)

<i>Mental status</i>	<i>Median age of talking (in months)</i>	<i>Range of ages (in months)</i>	<i>Average superiority of the normal group</i>
Normal	15.8	9-25 (90% 10-21)	18.6
Feeble-minded	34.44	12-156 (90% 14-84)	
Normal boys	16.5	Greater for boys	19.26
Normal girls	15.5	than girls with	14.50
Feeble-minded boys	35.76	both classes	
Feeble-minded girls	30.		

It will be seen that the median age of beginning to speak is 18.6 months earlier with normal children, that the range of ages at beginning is 128 months greater with the feeble-minded, and that in both these respects the defective boys are inferior to the defective girls. With lower grade feeble-minded children the discrepancy is much greater, and in many such cases the children are entirely dumb. Mead (25) found of one hundred consecutive cases admitted to the Indiana School for Feeble-minded Youth fourteen per cent dumb, and thirty-seven per cent more to have defective speech.

Even more significant as a mark of intelligence is the rate of progress and the kind of progress made in mastery of speech. Dr. Clara H. Town (45), from a careful study of the language development of 285 idiot and imbecile children

in the Lincoln State School and Colony, finds "a distinct age correlation for the successive levels of language development, and just as distinct a correlation for the various speech defects, with the single exception of stuttering." Of seventeen low-grade idiots, two understood gestures, four could make them voluntarily, but none could imitate them. One understood a few words, but none could speak a word. Of twenty-five high-grade idiots, on the other hand, nearly all understood, imitated, and made voluntary gestures, fourteen understood and ten could speak a few words. By the use of 320 test words, suggested to the children by pictures and objects, Dr. Town got a somewhat incomplete estimate of the vocabularies of twenty-five low-, ten middle-, and ten high-grade imbeciles. The tests showed a steady increase in vocabulary from the lower to the higher levels, and further indicate a distinct inferiority in size of vocabulary when these children are compared with normal children of the same mental age. The accompanying table presents a brief summary of Dr. Town's results, showing the number of words actually used by these children and the number of the test words known by them.

TABLE VII
VOCABULARY TEST — IMBECILES
(After Town)

<i>Class</i>	<i>No.</i>	<i>Ages</i>	<i>Mental ages</i>	<i>Test words used</i>	<i>Total no. words used</i>
Low-grade.....	13	6-28	3	30-139	112
Low-grade.....	12	7-17	4	90-195	188
Middle-grade.....	10	7-13	5	155-265	815.5
High-grade.....	10	9-14	6	250-299	263

Word tests. Whipple (63, p. 14) has pointed out that the greater the number of words used explicatively, rather than merely indicatively, the higher the intelligence is likely to be. Derver (11) has recently urged the point that definite marks of definite stages of mental growth are to be found in the relative preponderance of certain parts of speech, of certain classes within some of the parts of speech, and in the facility with which words of these classes are acquired. Most of the vocabulary studies show a relative preponderance of verbs in infancy, to use a striking example. Interjectional elements are also out of all proportion in the early stages of speech learning. The rapid acquisition of nouns depends largely upon the enrichment and expansion of the child's environment, but rapid increase in the number of adjectives and adverbs evidences an increasing ability to note the qualities of objects and to refine one's thinking about them, and is therefore a better symptom of mental growth. Certain groups of words, such as color terms and the demonstrative adjectives, are often acquired quite suddenly, and so seem to mark steps in mental development following periods of acquisition and assimilation of knowledge. The use of relative pronouns and subordinating conjunctions implies ability to handle complex sentences, and therefore marks a higher mental capacity than does the correct use of the personal pronouns. So, too, adverbs of place are usually first used. Those of time, degree, and manner may mark successive levels of intelligence. If further investigations prove such correlations to be fairly constant and uniform, the use of mental tests, involving command of definite phases of speech, is likely to be fruitfully extended. Already certain of the linguistic tests have proved to be very useful.

The method used in definition of words and the success of such definition has also been used as an index to mental

development. This was early suggested by such studies as those of Binet, Barnes, and Shaw (38), in the last of which a comparison of the results of the three studies is to be found. Definitions by action or use, as "an orange is to eat," strongly predominate in early years over definitions by subsumption under the larger term, as "an orange is a fruit"; and definitions in which descriptions of the qualities, substance, or structure of the object are attempted, as, "an orange is yellow, round like a baseball, it has a thick rind and is sweet," etc.

Considerations in judging intelligence. In judging intelligence by the use of speech there are, then, several important considerations, as pointed out by Dr. Louise Ellison (13) and others, and as used in the various series of intelligence tests. The more important are: (1) the age of learning to speak; (2) the size of vocabulary relative to others of the same age; (3) the kind of use made of words; (4) the method of definition and the success of definition; (5) general command of speech, as shown in: (*a*) ability to supply missing words in a connected story (completion test); (*b*) ability to rearrange a mixed group of words into a simple sentence ("to asked exercise my teacher correct my I"); (*c*) comprehension of a passage read; (*d*) ability to give the opposites (large — small) of words; and many others.

It should always be kept in mind that there are other important modes of linguistic expression in the broader sense, and that there are notable individual differences in the speech capacity proper without corresponding differences in intelligence. Ogden (30, p. 53), after a long-continued series of experiments, contends "that knowing is not identical with expressing, if by expressing we mean a relatively adequate interpretation of that which is known." He finds that knowing, thinking, and expressing are different processes. "Indeed, there are many who possess a facility of

expression quite beyond the demands of their feeble knowledge, while others, though deep and effective thinkers, are condemned to struggle constantly with their deficiencies in expressive art." So, while the latter class are at a distinct disadvantage, since speech is the organ of thought *par excellence*, the *sine qua non* for the transmission of many phases of culture from age to age, such persons are not necessarily inferior in intelligence. The casual observer is likely also to be misled, as Binet (45, pp. 229-30) has shown, by reason of the fact that many children of very low intelligence, provided they have reached the seven-year level, have quite free and fluent use of speech. It is only as the quality of their speech is carefully observed that their deficiencies are seen.

SUMMARY

1. Speech is an innate capacity acquired chiefly by exercise of voice play, self-expression, and imitation.
2. Acquirement is quite as much a matter of enriched sensory-motor experience and mental growth as of learning words.
3. In early stages children naturally violate all the conventional usages of speech, and aim directly and forcefully at expression of ideas.
4. Material and linguistic environment are the chief stimuli for the acquisition of vocabulary and the mastery of the forms of speech. Both create an insistent demand for additions to vocabulary which should be patiently and carefully met. Either has more value than formal instruction.
5. Plenty of opportunity for well-directed practice of speech is a *sine qua non* of good linguistic training.
6. Wealth of linguistic expression is a most marked trait of early childhood and a vital need in mastery of speech.

7. Association with older persons develops speech more rapidly than that with other children.
8. "Baby talk" is detrimental to both linguistic and mental development.
9. Verb inflections, use of connectives and subordinating words, and the mastery of the complex sentence are the most difficult elements of speech. Abstract concepts of number, space, color, time, and the like are acquired relatively late, and are an outgrowth of experience.
10. The use of slang is natural. It is an evidence of poverty of vocabulary and is to be combated chiefly in a positive way by enrichment and perfecting of vocabulary through reading, actual experience, and practice of precision under direction.
11. The successful direction of linguistic development demands an intimate knowledge of the laws and tendencies of spontaneous speech.
12. Linguistic tests are among the best available means of determining intelligence. In this the kind rather than the size of vocabulary is most important; the kind of use made of vocabulary rather than its content. Tests along this line can and should be widely extended and used.
13. The development of speech is one of the richest fields for future study.

QUESTIONS AND TOPICS

1. Differentiate speech from language.
2. What instinctive tendencies are the basis for speech?
3. Show the superiority of the human physiological and psychological equipment for speech over that of animals.
4. What are the hereditary and what the acquired elements in speech?
5. Of how much importance has the possession of speech been in the mental and social evolution of man? Explain.

6. With your answer to the last question in mind, discuss the place and importance of speech in the development of individual intelligence.
7. Study some of the linguistic tests used in the Binet-Simon or Stanford intelligence scales, and explain why they are good indications of intelligence.
8. Discuss the important facts about children's vocabularies and their development.
9. Explain with some detail the way in which words acquire meaning.
10. Just what things would you do to help a child acquire a large and rich vocabulary?
11. Explain the attractiveness of slang.
12. Why does the study of grammar often have but little effect upon speech?
13. What definite suggestions for linguistic teaching at home and in school do you draw from the facts of natural development of this capacity?
14. Why may speech be spoken of as the most distinctively human capacity?
15. Secure and study the definitions of a few common words by children of different ages as, for example the word animal.
16. Try out the completion or opposites tests and study the results.
17. Make careful analysis of the speech of several children whom you judge to represent different levels of intelligence.
18. Question a number of children and adults as to why they use slang.

SELECTED BIBLIOGRAPHY

1. Ballard, P. B. "Sinistrality and Speech"; in *Jour. of Exp. Ped.*, vol. 1, pp. 298-310.
2. Barnes, E. "How Words Get Content"; in his *Studies in Education* (1902), vol. 2, pp. 43-61.
3. Barnes, E. "A Study of Children's Interests"; in his *Studies in Education* (1896-97), vol. 1, pp. 203-12.
4. Chamberlain, A. F. *The Child: A Study in the Evolution of Man* (1900), pp. 107-71.
5. Chamberlain, A. F., and Chamberlain, Isabel C. "Studies of a Child"; in *Ped. Sem.*, vol. 12, pp. 425-53; and vol. 16, pp. 64-103.
- *6. Chambers, W. G. "How Words Get Meaning"; in *Ped. Sem.*, vol. 11, pp. 30-50.
7. Chrisman, O. "The Secret Language of Children"; in *Child Study Mo.*, vol. 2, pp. 202-11; also *Century*, vol. 56, pp. 54-58.
8. Conn, H. W. *Social Heredity and Social Evolution* (1914), pp. 43-71.
9. Conradi, E. "Children's Interest in Words, Slang, Stories, etc."; in *Ped. Sem.*, vol. 10, pp. 359-404.

10. Conradi, E. "Psychology and Pathology of Speech Development in the Child"; in *Ped. Sem.*, vol. 11, pp. 328-80.
11. Derver, J. "A Study of Children's Vocabularies"; in *Jour. of Exp. Ped.*, vol. 3, pp. 34-43; 96-103; 182-188.
12. Drummond, W. B. *An Introduction to Child Study* (1908), pp. 256-76.
13. Ellison, Miss L. "Children's Capacity for Abstract Thought as Shown by their Use of Language in the Definition of Abstract Terms"; in *Am. Jour. Psy.*, vol. 19, pp. 253-60.
14. Gesell, A. L., and Gesell, Mrs. B. C. *The Normal Child and Primary Education* (1912), pp. 159-80.
15. Giles, P. "Evolution and the Science of Language"; in *Darwin and Modern Science* (1909), pp. 512-28.
16. Groos, K. *The Play of Man* (1901), pp. 31-48; 294-300.
17. Hall, G. S. *Adolescence* (1905), vol. 2, pp. 454-80; also *Youth* (1907), pp. 238-65.
18. Hirshberg, L. K. "'Dog-Latin' and Sparrow-Languages used by Baltimore Children"; in *Ped. Sem.*, vol. 20, pp. 257-58.
19. Jamgotchian, M. K. "Sparrow Language, the Secret Language among the Armenian Children"; in *Ped. Sem.*, vol. 20, pp. 98-99.
20. Judd, C. H. *Psychology* (1907), pp. 248-73.
21. Kirkpatrick, E. A. *Fundamentals of Child Study* (1907), pp. 222-43.
- *22. Lukens, II. T. "Preliminary Report of the Learning of Language"; in *Ped. Sem.*, vol. 3, pp. 424-60.
23. Major, D. R. *First Steps in Mental Growth* (1906), pp. 278-333.
24. Magni, J. A. "Department of Child Linguistics"; in *Ped. Sem.*, vol. 17, pp. 213-18.
- 24a. McDougall, R. "The Child's Speech"; in *Jour. of Educ. Psy.*, vol. 3, pp. 423-29; 507-13; 571-76; vol. 4, pp. 29-38; 85-96.
25. Mead, C. D. "The Age of Walking and Talking in Relation to General Intelligence"; in *Ped. Sem.*, vol. 20, pp. 460-84.
26. Melville, A. H. "An Investigation of the Function and Use of Slang"; in *Ped. Sem.*, vol. 19, pp. 94-100.
27. Monroe, P. (edit). *Cyclopedia of Education*. (Under "Language," "Speech," "Vocabulary," etc.)
28. Montessori, Maria. *The Montessori Method* (1902), pp. 310-25.
29. Moore, Mrs. K. "The Mental Development of a Child"; in *Psych. Rev. Mon. Sup.*, no. 3. (1886.)
30. Ogden, R. M. "Knowing and Expressing"; in *Ped. Sem.*, vol. 18, pp. 47-53.
- *31. O'Shea, M. V. *Linguistic Development and Education*. (1907.) 347 pp. (Bibliography.)
32. Partridge, G. E. *The Genetic Philosophy of Education* (1912), pp. 229-45.
33. Perez, B. *The First Three Years of Childhood* (1889), pp. 234-62.
34. Preyer, W. *The Development of the Intellect*. (1889.) 317 pp.

35. Preyer, W. *Infant Mind* (1893), pp. 84-122.
36. Scripture, E. W. *Stuttering and Lispings*. (1912.) 251 pp.
Best English reference on the subject.
37. Sechrist, F. K. "The Psychology of Unconventional Language"; in *Ped. Sem.*, vol. 20, pp. 413-59.
38. Shaw, E. R. "A Study of Interests"; in *Child Study Mo.*, vol. 2, pp. 152-67.
39. Shinn, Miss M. W. *Biography of a Baby* (1900), pp. 224-37.
40. Snyder, Miss A. D. "Notes of the Talk of a Two-and-a-Half-Year-Old Boy"; in *Ped. Sem.*, vol. 21, pp. 412-24.
41. Sully, J. *Studies of Childhood* (1895), pp. 133-90.
42. Swift, W. B. *Speech Defects in School Children*. (1918.) 125 pp.
43. Tanner, Miss A. *The Child* (1915), pp. 392-423.
- *44. Terman, L. M. *The Hygiene of the School Child* (1914), pp. 335-61.
Good discussion of speech defects.
45. Town, Miss C. H. "Language Development in 285 Idiots and Imbeciles"; in *Psych. Clinic.*, vol. 6, pp. 229-35.
- *46. Tracy, F., and Stimpff, J. *The Psychology of Childhood* (1909), pp. 119-65.
- *47. Trettien, A. W. "The Psychology of Language Interest in Children"; in *Ped. Sem.*, vol. 11, pp. 113-78.
48. Williams, Miss L. A. "Children's Interest in Words"; in *Ped. Sem.*, vol. 9, pp. 274-95.
49. Wolff, Miss F. E. "A Boy's Dictionary"; in *Child Study Mo.*, vol. 3, pp. 141-50.

Typical Vocabulary Studies

50. Bateman, W. G. "Language Status of Three Children at the Same Ages"; in *Ped. Sem.*, vol. 23, pp. 211-40.
51. Bohn, W. E. "First Steps in Verbal Expression"; in *Ped. Sem.*, vol. 21, pp. 578-95.
52. Boyd, W. "The Development of a Child's Vocabulary"; in *Ped. Sem.*, vol. 21, pp. 95-124.
53. Brandenburg, G. C. "The Language of a Three-Year-Old Child"; in *Ped. Sem.*, vol. 22, pp. 89-120.
54. Brandenburg, G. C., and Brandenburg, Julia. "Language Development during the Fourth Year"; in *Ped. Sem.*, vol. 23, pp. 14-29.
55. Bush, A. D. "The Vocabulary of a Three-Year-Old Girl"; in *Ped. Sem.*, vol. 21, pp. 125-42.
- *56. Doran, E. W. "A Study of Vocabularies"; in *Ped. Sem.*, vol. 14, pp. 401-38. (Bibliography of 118 titles.)
57. Grant, J. R. "A Child's Vocabulary and its Growth"; in *Ped. Sem.*, vol. 22, pp. 183-203.

58. Heilig, M. R. "A Child's Vocabulary"; in *Ped. Sem.*, vol. 20, pp. 1-16.
59. Langenbeck, M. "A Study of a Five-Year-Old Child"; in *Ped. Sem.*, vol. 22, pp. 65-88.
60. Nice, Mrs. M. M. "The Development of a Child's Vocabulary in Relation to Environment"; in *Ped. Sem.*, vol. 22, pp. 35-64.
- *61. Pelsma, J. R. "A Child's Vocabulary and Its Development"; in *Ped. Sem.*, vol. 17, pp. 329-69. (Bibliography of 55 titles.)
62. Rowe, E. C., and Rowe, Mrs. N. H. "The Vocabulary of a Child at Four and Six Years of Age"; in *Ped. Sem.*, vol. 20, pp. 187-208.
63. Whipple, G. M., and Whipple, Mrs. G. M. "The Vocabulary of a Three-Year-Old Boy"; in *Ped. Sem.*, vol. 16, pp. 1-22.

CHAPTER VIII

CHILDREN'S DRAWINGS

DRAWING is an activity almost as universal in childhood as speech or play, though it is less persistent and less well perfected because less indispensable. Only play, of which in some respects spontaneous drawing is a form, reveals more of the inner nature of childhood. In drawing as in play the real child "comes out to meet the world." In no activity is it more clearly illustrated that impression tends to result in expression and that "all consciousness is motor." By drawing and other allied forms of artistic creativeness impressions are often more easily, more simply, and better expressed than by speech. Spontaneity, originality, and creativeness find here one of their truest, most impressive, and best manifestations with a clearness that few adults have learned to recognize.

Instinctive basis of artistic expression. As with play and with speech, the universality of drawing, the type forms it takes, and the spontaneous pleasure it brings argue for it also a strong instinctive basis. This seems all the more true since in expression in drawing children receive less systematic and persistent training than in either play or speech. The instincts of general physical and mental activity lead almost universally to drawing as one of their modes of expression often before the child is a year old, and almost always by the time he reaches one and a half. The tendency to manipulate objects usually brings the first drawings, often quite by accident, as one of its natural results. The innate tendencies to constructiveness and self-expression supplement aimless manipulation so as soon to bring about pur-

poseful creative efforts. The growth of memory and of productive imagination and the increase of capacity for observation, supplemented by the strong innate capacity for imitation, lend variety and little by little give form to the first crude creations. The enrichment of experience gives birth in time to æsthetic sensibility and to the increasing capacity for appreciation and enjoyment in ways which we as yet little understand. A combination of all these instincts, innate tendencies, and capacities results in spontaneous interest, amounting often to something like a passion for drawing, painting, and clay-modeling, as well as to the growth of the cognate interests in form, color, and beauty as expressed in pictures, plastic art, and in grace of movement in man and animals. So strong is this passion at certain stages and with many individuals that it asks only opportunity and media for its expression, and if these be lacking it often makes its own opportunity even in spite of opposition and attempts at repression. Of this the clandestine drawings, with which we used to fill our slates and decorate the margins of our books in the "good old days" when creative efforts of this sort were frowned upon by those teachers who exalted the intellectual at the expense of motor accomplishments, bear ample witness.

Racial origins. Of phyletic origins, of parallels between child and primitive art, and of recapitulation of racial stages, much has been written by such careful students as Chamberlain (9), Hall (15, pp. 528 ff.), Levinstein (15, pp. 506-10), and others. The obscurity in which these problems of the dim prehistoric past lie buried, the suppression and redirection of natural impulses by adults and by the effects of a complex environment, and the greater value of direct study of the actual work of children, all alike forbid our dwelling long upon details of this fascinating phase of the subject.

Whether artistic expression arose by chance as "the occupation of an idle moment" when, recognizing an accidental resemblance between some natural object and a well-known form, such as the human face or that of some animal, prehistoric man attempted to heighten that resemblance by his own creative efforts, is difficult to say. Whether the first rude art of man was the result of enforced efforts to supplement his crude capacity for communication by means of speech is equally difficult to determine now; or whether some still different circumstance in man's early history gave birth to this most distinctively human capacity we may never know. This much seems certain. The art impulse is universal, useful, pleasurable, self-revealing. No other animal possesses such a capacity. Certain it is also that the exercise of this capacity from time immemorial is not without its effect upon man himself. Increase of mental and manual capacity, acquaintance with the world of things, and capacity for observation and mastery of environment owe not a little to this creative impulse.

Parallels between the racial and individual development of æsthetic and creative capacity are too evident to escape attention. To admit this need not bind us to accept or to push too far their recapitulatory significance, nor, on the other hand, need we be blind to the fact that a study of primitive art holds something of value for the student of child art. A somewhat extended study of the art of primitive man has brought to the writer the following outstanding facts: Much of primitive art went into the decoration of the person. Painting or tattooing the body, or parts of it, decorating the person with ornaments, ear, nose, and lip rings, anklets, bracelets, necklaces, individual and traditional modes of dressing the hair, and of wearing the clothing which were often and still are for æsthetic as well as for mere utilitarian purposes, all alike evidence a feeling

for art. Another large part of primitive art expended itself upon the decoration of man's possessions. Examples may be found in carving and drawing upon shields, spears, bows, arrows, arrowheads, and other implements of war and the chase. Woman's art in basketry, blankets, pottery, and other implements about the home is found among primitive tribes in all parts of the world.

Many phases of primitive art show that drawing, carving, modeling, weaving, and the like are not mere idle pastime but have definite utilitarian as well as æsthetic values. Tribal symbols, totem poles, images, idols, inscriptions on altars, temples, walls of cave dwellings, cliffs, and the like have long been known to have religious and ceremonial uses. By these means the deities were pleased, implored, placated. Unfriendly "demons" of disease and other misfortunes were "frightened" or destroyed by the grotesque figures of the "medicine-man." The personal decorations above referred to quite as often served the purpose of charms, amulets, and fetiches as of mere decoration. The designs on pottery, blankets, and baskets were usually meaningful and purposeful, like the tattooing of the body, as is shown by the refrain of a primitive song, "Who can kill me now? I am tattooed, I am tattooed."

Drawing preceded written speech and gave rise to it. The message sticks of the Australian native, the drawings on bark, wood, soft stone, skins, bamboo, papyrus, etc., are the "books" and letters of primitive man. Picture writing gave to the world hieroglyphics, and later the alphabet. Much primitive drawing is, therefore, communicative and linguistic, as we have pointed out in our chapter on language.

In short, primitive art was and is a means of pleasurable activity, a means of sex attraction, of winning approval, of increasing prestige, a means of religious expression, of magic, of cure for disease, of heightening physical capacity

and increasing bravery, a means of perfecting knowledge of the world of things, a medium of communication, and, among other things, perhaps last a pure form of æsthetic self-expression and enjoyment. All this is a study by itself, and yet as we proceed to our attempt to trace the development of child art we shall perhaps better understand the wealth of individual initiative, originality, and spontaneity which confronts us when we know something of what the child has fallen heir to. Surely an activity which has played such a rôle in the life of our primitive forbears ought to fulfill its promise of tremendous value as a culture media for children. Through its exercise many phases of racial soul life should awaken again in each new generation.

Studies of children's drawings. Beginning with the study of Ricci (26) in Italy, in 1887, several score of studies have been made and published, a selection of the best of which we append in our bibliography. Some of the most suggestive consist of a large collection of drawings of individual children extending over a term of years and revealing the progressive changes in interest and capacity with age. Those of Miss Shinn, Mrs. Hogan, Jordan, Major, Brown, and others are typical. Others are mass studies, including analysis and interpretation of thousands of drawings by children of all ages. Barnes and his associates made several distinct studies, each with a particular problem or group of problems, and involving many thousands of returns. Lukens (21) collected 3400 drawings from children of two to sixteen years, including a number of sets from individuals. Schuyten collected 4000 drawings of the human form alone by boys and girls from three to thirteen in the schools of Antwerp. Large collections have been made in several German cities. With characteristic German thoroughness Kerschensteiner (20) has made the most extended, careful, and comprehensive study yet attempted. He spent seven years,

following the work of 58,000 children, and studying with especial care the work of 15,000 non-selected children and that of 2300 of exceptional ability. His investigation involved the examination of 300,000 drawings, and his report appeared as a book of 508 pages, containing reproductions of more than 1000 drawings, some of them in color. This book is a veritable mine of information on the subject. Hall (15) has résuméed all of these and many more studies, and has himself examined many thousands of drawings sent him from various parts of this country, as well as those published in the literature, and bases his suggestive chapter on the pedagogy of drawing upon such study. Of these drawings, and especially of selected ones of which he made special study, he says, "nothing in the whole wide domain of child-study, and indeed nothing in all the great art galleries of the world that I have seen, has so impressed me with the native spontaneity and creative originality of human nature as these" (p. 515). From these studies many interesting and fascinating things are to be learned about child nature, some of which it is our purpose to set forth in the pages that follow.

Genetic stages in drawing capacity. As in the development of speech, so in that of interest in and capacity for drawing, definite stages can be made out more or less clearly. Among the more suggestive and useful statements are those of Sully (30, p. 382), Tracy (32, pp. 172-78), Major (23, pp. 47-56), and Lukens (22), to mention only American writers. We shall follow in the main the stages outlined by Lukens.

(1) *The scribble stage.* The first form of drawing is well characterized as scribbling, and elements of it persist usually till four or five years of age. It may begin early in the second year, but often does not become a marked interest till the beginning of the third year. Scribble drawing passes through

several phases which Major (23) has analyzed in great detail. First there is a period, noted by almost all observers, of crude, impulsive, quite aimless pencilings, enjoyed quite as much it seems for the movements involved as for any objective result produced by them. Significant for its bearing upon the movement made in writing is the fact that the first spontaneous movements are from right to left. Aimless scribbling merges into what Major (23, p. 48) calls "purposeful pencilings," in which the results produced by the pencil become an object of interest and attention. This often leads to the chance recognition of likenesses between the scrawl of lines and some object known to the child; as, cat, man, mouse. This is apt to be followed by a period in which the child draws many figures, and after they are drawn assigns names to them as fancy dictates. The same sort of scrawl thus often serves many purposes. Next attempts are apt to be made, either with or without copies to imitate, at representation of objects as the child knows them. These are, however, usually descriptive rather than truly pictorial in form. Neither Baldwin (1, p. 80) nor Miss Shinn (6, p. 5), who have watched closely for this stage, find any apparent connection between the mental image and the movements used in attempting to represent that image before the twenty-seventh month. The difficulties encountered in attempts at representation often lead to requests that his elders "draw man — draw horse," and the like. The fact that help is so commonly given furnishes the basis for imitative drawing, and also no doubt gives something of conventionality to the symbols commonly adopted by most children for the objects they most frequently draw, such as man, horse, dog, and house. Baldwin (1), Lukens (21), and others have called attention to the fact that the first imitation occurring in this stage is usually of the movements of the teacher's hands rather than of the copy or model. The

rather unusual drawings of man by Miss Shinn's niece (6, p. 26), who was not given models to copy, seem to indicate that the symbols so commonly adopted by children may be more imitative than spontaneous.

Apparent or real retrogression in ability to symbolize or depict is often seen with the dawn of attention to detail. This, plus the resultant dissatisfaction with his own efforts, may account for the very marked lapses of interest, sometimes of weeks' or even months' duration, which children often show. At such times the child prefers to have others draw for him rather than to draw for himself. These periods of attention to detail tend to obscure the descriptive nature of drawings. The child will draw part by part, naming each as he draws it, but with so little attention to relation of parts that when the drawing is complete it becomes an unrecognizable scrawl which one would not think of as descriptive had one not seen it drawn. Miss Shinn has well illustrated this point (6, p. 12). Her illustration also shows how necessary it sometimes is to study the child at his work as well as to study the finished product of his effort if we hope to get a correct understanding of an activity. This temporary apparent retrogression, although discouraging to the child, is really a step in progress to the following stage. The first definite attempts at representation with attention to details, as for example the parts of the human figure, tend definitely to take the form of what Lukens calls "scribbling localizations," which is a sort of transition between scribbling and symbolization.

(2) *Artistic illusion.* When a child has gained some ability to depict what is in his mind with some relation to its appearance as he knows it, even if this be quite symbolic rather than pictorial, he has reached a stage in mental and manual development which gives a new motive to drawing. Barnes (4, p. 302) was one of the first to insist that for chil-

dren drawing is a language as much of it was for primitive man. This becomes peculiarly true at about six to eight years. The drawings of the scribbling stage are in a vague way self-expressive, but those of this period are expressive in a very much more definite way of thoughts, ideas, scenes, stories. Representations of objects are still very crude but relationships are worked out, activities pictured, scenes portrayed, and stories told with the pencil. Small attention is paid to beauty, symmetry, proportion, or balance, and almost none to perspective. Decorative details receive attention, often one at a time, until fair success is attained with them. Buttons, hats, hair, watch chains, and the like are examples of the decorative elements attempted in drawings of the human figure.

This is an imaginative and non-critical stage, a period of pre-artistic play. The finer points of technique are now non-existent and of little value to the child artist. The grossest violations of all the categories of art do not disturb him in the least, and, if we understood, ought to disturb the teacher far less than they do. His efforts often take the form of disconnected symbolism, which Barnes has called "cataloguing." All agree that now the child draws what he knows about objects, not what he sees. A few telling lines commit his ideas to paper and he is pleased and satisfied with the result. Often he cares little or nothing for his effort after it has served its immediate purpose. The period is often a prolific one, full of creative effort of a most valuable sort if initiative, spontaneity, self-expression, and creative effort are of any value. Lukens gives details of the prolific expression of one boy whose work was followed for a year, and thinks the value of it in an educational way may compare favorably with all that is learned in school during a similar period (21). "Here," says Chamberlain (9, p. 209), "the child is likest the real artistic genius, whose product is more

of a substitute for than a strict imitation of nature." As we have already said, here genius often begins to show itself if allowed freedom to follow its own devices. Lukens feels that it is little less than criminal for the teacher to say to the child, while this period is on: "Open your eyes and see the tree and the fruit thereof, as they really are. Draw the apple exactly as you see it. The pupil does so, and his eyes are opened, and he sees his nakedness, and is filled with shame. The divine gift of artistic illusion vanishes; he awakens to find that he cannot draw" (22, p. 946). Thus the "golden age" is too often destroyed.

(3) *The self-conscious period.* But if not the teacher, other factors are at work to bring self-consciousness and with it discouragement and loss of interest. Increase of intellectuality, increase of æsthetic appreciation, improvement of the power of observation, and the repressions of environment as well outside as inside the school, bring the child sooner or later "to see that his drawing is nothing more than a poor, weak imitation of nature, and the charm of creative art vanishes with the disappearance of the former naïve faith" (9, p. 209). Thus is ushered in what has well been called the plateau stage, where the child's best efforts bring results far below his ideals and where progress is slow and painful, if indeed there is progress at all. Most children reach this period at from twelve to fourteen years. Many never get beyond it. Effort and initiative diminish or cease with many, and it requires the greatest skill on the part of the teacher here, as in similar periods for other accomplishments, to tide the child over this period by means of external incentives and what may perhaps seem unmerited encouragement. Mechanical drawing and decorative art, where defects are less serious and glaring, may keep interest from failing altogether, and, if progress has been good in the preceding period, without destruction of originality or th

arousal of too much self-criticism, the transition may be the more easily made.

(4) *The period of rebirth of artistic ability.* Often at fifteen or sixteen years, if not earlier, there comes for the favored few a rebirth of artistic interest and a rapid increase of artistic ability. This is correlative with the many similar changes which accompany adolescence. The final increment of growth brings something of adult size and proportion of parts. Approaching physical maturity makes possible motor coördinations and control entirely impossible in early years. All intellectual capacities are now ripening into mature form so that observation is more accurate, attention and will more subject to control, judgment more trustworthy and exact, and capacity for æsthetic appreciation greatly increased. The higher emotions have begun their dominating influence, and desire for worthy accomplishment and social approval were never so strong. Drawing is no longer merely an interesting activity, nor merely a means of expression useful for the moment. Drawing now for most becomes for the first time truly artistic. Interest in the art value of the product arouses interest in the technique of accomplishment, which till now has been of little concern. Now the school may prescribe technique, the grammar of drawing, for suggestions for improvement were never so eagerly sought or so readily accepted. Most children, who attain them at all, now gain the capacities of accurate and artistic representation of objects in three dimensions. For those who attain the higher capacities possible at this stage, drawing and other forms of art often become a passion once more as for many they are in early childhood. The great majority, however, never reach the point of high productive capacity, but must content themselves with enjoyment of the work of others.

What children draw. Children draw a great variety of things. One of the striking facts is the daring which at early

stages leads them to attempt the impossible. The wind, the breath, the soul, heaven, or God, will be almost as readily attempted as things which can be seen. Certain dominant interests, however, consonant with other lines of interest, are easily recognizable. A number of studies have reduced them to percentages. Without carrying accuracy to such an extent, especially since many drawings contain two or three of the dominant interests, a few tendencies may be mentioned. Younger children have decided preferences for human and animal forms; then come plants and flowers, houses, still-life objects; and last, conventional design and ornament, and in practically this order. Nearly three fourths of the spontaneous drawings of six-year-olds either are of or contain human figures. From fourteen years on the order of interest is almost exactly reversed, ornament and design standing first, houses and human figures lowest, with plants and animals occupying middle ground at about one third their relative interest at six.

Another striking and significant discovery is that little children rarely draw spontaneously from objects present. They draw absent objects as they remember them. Neither do they draw from the object as they see it when it is present, but rather they represent its striking features as they know them. Lukens found his attempt to have young children draw a representation of himself seated on a sofa a failure. The child used his usual symbol for man — a standing figure — and drew the sofa behind it as a relatively unrelated separate object. Six-year-olds are not given to pictorial art.

The linguistic character of drawing is well seen in children's illustrations of stories. Those of "Johnny-Look-in-the-Air," as reproduced in Barnes's *Studies in Education* (2, pp. 102-04; 154), and those of "Goldilocks and the Three Bears," as collected by Miss Flanders and reproduced by

Miss Tanner (31, pp. 472 ff.), are good illustrations among numerous others that have appeared. Any teacher can easily collect similar ones. Barnes found an increase in the number of different scenes to thirteen, with a decrease thereafter to sixteen years. Miss Flanders found much the same with fragments of scenes very common in the kindergarten and first grade. Almost all the drawings of the Goldilocks story are of landscapes rather than interior views, although the story strongly suggests the latter. Even with the eighth-grade children, who attempt more interior views, not more than twenty per cent did so. Barnes found that the scenes chosen are as a rule not the crises of the story, but points just before a crisis.

There is every reason why serious consideration should be given to the spontaneous drawings of children in planning both the content and the method of courses in the subject. In no capacity are spontaneity and originality more precious; in none has the school more consistently ignored them. Fortunately, such studies as we here refer to have in recent years brought some radical reforms in art teaching, with most encouraging results.

Characteristics of children's drawings. The outstanding characteristics of children's drawings almost all appear in their attempts to depict the human form, which is the most prominent interest all through early childhood. The "pictorial evolution of man," as Lukens calls it, has been made the subject of most minute and detailed study by Partridge (15, p. 163), Brown (6), Lukens (21), Schuyten (15), Sully (30), and others, all of whom publish many typical drawings for each period. The study of a series of such drawings of an individual child, extending over a term of years, is one of the best possible indices of the progress of mental and manual development. Every teacher should sometime attempt some such study. Such a series is still more en-

lightening if one can observe steadily the actual drawing of the figures, making note of the procedure, the comments of the child as he draws, and supplementary notes of one's own at the time.

To begin with, the child, like the artist, uses every line but the straight line. His figures are in outline rather than in mass. It is perhaps uncertain what the result would be if children were allowed as free use of water-colors and brush as they are of pencil. We know of no published study in which the experiment has been thoroughly tried. As far as the studies go, it seems clear that use of mass and color are acquired much later than line and outline. Early drawings of the human figure are very incomplete as to parts, as all of the published drawings show. After the scribble stage is passed, an irregular circle, with the addition of eyes and mouth, often completes the figure. Soon lines for arms and legs are added. The figures seem symbolic, but yet there is often, for the child at least, individuality in them. As one traces the addition one by one of other details, it is evident that the incompleteness of the drawing indicates roughly the crudity of the child's ideas of form. Perhaps he sees clearly only those parts that he draws. He assimilates things first as wholes, and only later learns to analyze them into parts. Perhaps it is the mobility of limbs and the expressiveness of the features of the face that attract attention to them first. However that may be, it is only gradually that body, neck, hands, feet, fingers, hair, ears, and various articles of clothing come to be recognized as essential parts which should be shown in the drawing. Profile drawings are, according to Barnes, not common before six years, are about equal to full face drawings at nine, and first attempts are often ridiculously crude. Often they are strangely mixed, half-profile, half-front views. Right-handed children usually draw profile figures facing the left. Double lines for repre-

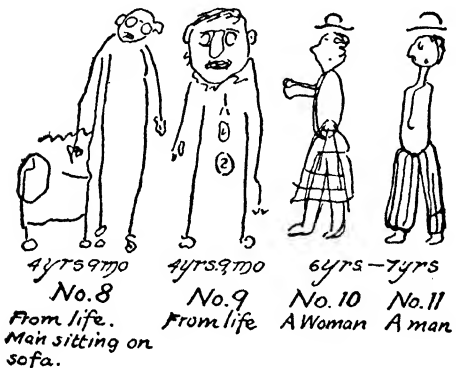
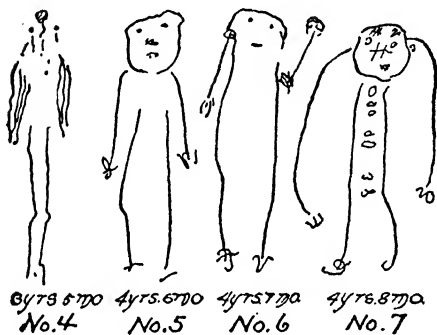
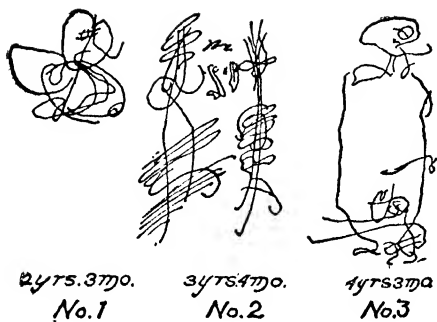

FIGURE 10. THE PICTORIAL EVOLUTION OF MAN

(After Lukens, *Ped. Sem.*, vol. 4, p. 102, by permission of G. Stanley Hall.)

sentation of the limbs are also usually lacking till the sixth or seventh year.

In general, incompleteness, lack of proportion, balance, unity and relation of parts, absence of perspective, inconsistencies, and other defects are striking features of all child drawings for some years. It has often been suggested that the defects shown in drawings are evidence of parallel defects in power of observation and capacity for thought. There is no doubt truth in the statement, provided it is not pushed too far. The same sort of crudities of thought will be brought out in our section on "Reasoning." We must not, however, think of the child's ideas of objects as being crude to anything like the same degree as his drawings. Most of us would hesitate to have the accuracy and completeness of our ideas of objects judged wholly by the correctness of the drawings we could make of them.

The fact that for a long time drawings of the human form or of animals absorbs most of the interest of most children is in keeping with interests in other fields. Living, moving, dynamic objects, rather than static ones, are always chosen. Even when still-life objects are drawn, the dynamic nature of childhood often asserts itself. Smoke pours from the chimney of the house or engine, the trees sway in the wind, some living thing is indispensable to the landscape, the flowers have faces, all nature is animate to the child. Many other interesting details may be found in any of the type studies. We cannot follow them further.

Individual and sex differences. The art of primitive man differed from that of primitive woman. The art capacity and the interests of boys and girls differ no less. Kerschensteiner (15, p. 512) was so impressed with the sex differences that he holds that there should be different courses for boys and girls in the elementary schools. We shall attempt to give a condensed summary of the more significant sex differences

that have been clearly brought out in the various researches. For this summary we are chiefly indebted to Hall (15, pp. 493 ff.), who has culled them from widely scattered sources, although he does not bring them all together in a paragraph as we shall try to do.

Hart found that in choosing pictures boys prefer battle scenes with plenty of action, but girls' choices depended more on secondary elements. Color interest declines more rapidly with boys than with girls. Lay found that objects spontaneously drawn or modeled by boys differed materially from those chosen by girls. Of children studied by Katz-eroff the girls more often drew objects right about them than did the boys. Schuyten's study of drawings of the human form shows that girls remain longer in the first and second crude stages than do boys, and that the third stage is less well developed in them. Kerschensteiner adds to this that the conscious stage of perspective is attained two or three years later by girls than by boys, and that boys attain the stage of perfect representation earlier and more perfectly than girls. According to Levinstein girls tell in pictures more voluminously than boys. Boys draw taller and girls broader representations of persons (Schuyten). Kerschensteiner found that the tendency to rhythmic decoration of surfaces came earlier and was more developed with girls than boys, and thinks dress is a factor. The boy's superiority in representation of a whole in space he attributes to a better power of grasping general appearance.

Girls surpass boys in accuracy of color perception, and are less often color blind. Schuyten found no differences between boys and girls in choice of the four colors standing in highest favor, but Jastrow, from 4500 records, found that the favorite color of women and especially young girls is red, while that of men is blue, and that this difference is decisive. Women also named more colors and more shades.

In ability for artistic expression it seems that on the whole boys have the better of it, though not always so from the standpoint of the school, for, as Hall says, boys are more original, but girls do better conventional school work. The great geniuses in art have been men with few exceptions. Ivanoff found more boys among the good and more girls among the bad drawers, yet the correlation between ability in drawing and general ability is closer with girls than with boys.

Turning to individual differences, we find that while the general features of children's drawings, taken *en masse*, are much the same for a given age, especially in the early years, yet, as Kerschensteiner (15, p. 511) found, after eight years individual differences between members of the same sex are very marked. Artistic genius often shows itself early. Burnham (8, p. 292) cites the names of ten great artists, all of whom showed marked promise between the ages of seven and thirteen. In choice of subjects to draw there is the widest range, especially after the beginning of the school age. Lay found 51 children, 28 girls and 23 boys, made in two and one half hours 230 things, "sampling almost every domain of nature and human life" (15, p. 505). Burnham believes it is too much to say that drawing is the natural means of expressing thought for all children, holding that the study of individuals will show that for many children "it is no more so than paper-cutting, or clay-modeling, or perhaps some other motor activity, such as running, pantomime, and various forms of dramatic impersonation" (8, p. 301). These facts should be had in mind in the preparation of art courses for schools, so that no one form of art and no narrow prescription of subjects should be held to for all children even of the same sex, and still less for those of different sex.

Correlations. Drawing calls for self-expression and motor

ability. We should expect close correlations between it and abilities calling for these same capacities. A few studies have given attention to the matter. Kik (15, p. 512) finds positive correlation between drawing and other capacities, that for arithmetic being lowest. Ivanoff (15, p. 496) also found high correlations with geography, history, manual work, and visual memory subjects generally, but a low one with arithmetic. The visual type and the reflective type usually have radically different capacity for drawing and need different treatment. In spite of the fact noted by several observers that those who draw well are also usually good in other subjects, it not infrequently happens that backward and defective children draw quite well. The reasons for this, so far as we know, have not been carefully studied. The whole subject of correlation of drawing ability with other capacities, and with mental ability in general, is one upon which too little investigation has yet been made to warrant any very definite conclusions.

Values of drawing. The values of spontaneous drawing and other forms of artistic expression are many and important. By means of them images and concepts, discriminations of form, dimension, and color are developed and perfected, and by being thus objectified by the child himself, images having become clearer and more definite are better remembered. Drawing trains the eye to see and the hand to execute, and furnishes one of the best means of discovery of inaccuracies and disabilities along these lines. New interests arise, those present are intensified, and both are revealed to those who take the trouble to observe child art sympathetically.

Many phases of mental content, of psychic activity, and the degree and nature of motor capacity are more clearly revealed in drawing and constructive work than in almost any other way. Hall (15, p. 515) says, "if we only had a

complete collection of all the drawings of a single child with proclivities for art, but who had been unrepressed by criticism or derision, we should find its very soul in each developmental stage represented." Such work prepares the way for æsthetic enjoyment and the development of taste for good art at the proper time.

Geometric and mechanical drawing have a value of their own in this day of increasing use of charts, graphs, curves, and pictures, in presentation of the results of scientific statistical studies, of arts, industries, and all phases of life. Many books and magazine articles require for intelligent reading a knowledge of this visual language.

Drawing, too, is healthful and hygienic, and prepares in a natural and easy way for the more exacting task of writing. Burnham (8) has pointed out, with great definiteness, hygienic values quite commonly overlooked — the healthfulness of any normal productivity, the normalizing of emotional life through such expression, and the sanifying and developing effect of objective interests and appreciations of which we have none too many. Lukens (21) even suggests that drawing has a cathartic effect of real moral value, and believes that some indulgence in depicting forbidden subjects may inoculate against the harmful indulgence of evil tendencies themselves.

The aims of art teaching should then be clear. The primary purpose should be the development of children rather than the making of artists. Spontaneity, initiative, and originality should be encouraged rather than repressed. The young artist must be kept in close and sympathetic touch with life, on levels well within the range of his interest and capacity. Ideals should not be set so high as to be unattainable. They must be his ideals, not those of the teacher. Teachers should cease to attempt to get from children in the fifth grade work that looks like that of eighth-grade chil-

dren. If art work lent itself less easily to exhibit purposes its educational values would less often suffer than now. As Hall suggests, we often lose sight of the value of drawing to the child in our attempts in our exhibits to evoke from the unthinking the exclamation, "How pretty!" It is a misfortune that, as Chamberlain says (9), "for ten geniuses of the nursery in drawing there remains hardly one in the high school." Kerschensteiner's (20) study also suggests that many children with exceptional ability are often not discovered in the ordinary course of school work. Teachers should discover and develop originality and individual capacity in this as in other lines, and special training should be open to all who have talent. For most children the final result aimed at should be the cultivation of æsthetic appreciation, rather than artistic creation of a high order. Training of hand and eye must result in cultivation of mind and heart. A few will become artists and art critics; the great majority should become lovers of art.

SUMMARY

1. Artistic expression in some form is almost universal. At its basis lie the innate tendencies to manipulation, constructiveness, self-expression, communication, æsthetic responsiveness, imitation, and perhaps others.
2. There are interesting and instructive parallels between the art expression of children and that of the race, both as to the kinds of interests and the forms of execution.
3. There are well-marked stages in interest in and capacity for drawing paralleling those in speech, and indicative of mental as well as manual development. A plateau stage characteristic of nearly all learning is clearly indicated.
4. The development of æsthetic appreciation and manual ability do not run parallel, but improve in turn.

5. Some of the most striking characteristics of children's drawings are the following: —
 - a. The preponderance of line and outline over mass and color, although this may be due to necessity and to imitation rather than to spontaneity.
 - b. Incompleteness, lack of balance, unity, proportion, and composition.
 - c. Unconventionality, boldness, originality.
 - d. The preponderance of the pictorial over the decorative in early stages.
 - e. The prevalence of pictographic and linguistic drawings.
6. Interest in a finished product and in the technique of accomplishment comes relatively late.
7. Rightly used, drawing, paper-cutting, clay-modeling, and other forms of artistic expression have educational values as yet little realized.

QUESTIONS AND TOPICS

1. What are the instincts and innate tendencies which chiefly contribute to interest in drawing, painting, modeling, and the like?
2. Are there any significant parallels between the drawings of children and those of primitive peoples? What conclusions do you draw from them?
3. Enumerate the striking characteristics of children's drawings.
4. What definite traits of children are revealed in a study of their drawings?
5. What changes of interest in drawing with age are most marked? Explain them.
6. What relation has artistic ability to other capacities? Explain the relationship or lack of relationship.
7. Are artists born or made? Explain fully.
8. Do you think that marked ability for art work could be determined at an early age by a series of tests? What elemental capacities should they seek to test?
9. Explain the unusual fascination of clay work for children.
10. What relation does expression in art bear to art appreciation?

11. Does artistic ability in drawing, clay, metal, or wood bear any relation to that in music? Why or why not?
12. What aims for art teaching does a study of the spontaneous art expression of children suggest?
13. What are the educational values of art expression and the study of art?
14. Bringing all our knowledge of child hygiene to bear, what are the important hygienic problems involved in art teaching?

SELECTED BIBLIOGRAPHY

1. Baldwin, J. M. *Mental Development in the Child and the Race; Methods and Processes* (1895), pp. 78-88.
2. Barnes, E., and others. *Studies in Education* (1896-97), vol. 1, pp. 22-23; 62-64; 102-06; 154-55; 178-81; 283-94; 338-43; 367-68. (Illustrated.)
- *3. Barnes, E., and others. *Studies in Education* (1902), vol. 2, pp. 34-35; 74-77; 109-11; 151-54; 163-79; 231-33; 271-73; 314-17; 352-55; 388-91. (Illustrated.)
4. Barnes, E. "The Art of Little Children"; in *Ped. Sem.*, vol. 3, pp. 302-07.
5. Barnes, E. "A Study of Children's Drawings"; in *Ped. Sem.*, vol. 2, pp. 455-63.
- *6. Brown, E. E. (editor). "Notes on Children's Drawings"; in *Univ. of Cal. Studies* (1897), vol. 2, no. 1, 75 pp. (Illustrated. Bibliography.)
7. Burk, F. L. "The Genetic Versus the Logical Order in Drawing"; in *Ped. Sem.*, vol. 9, pp. 296-323.
- *8. Burnham, W. H. "The Hygiene of Drawing"; in *Ped. Sem.*, vol. 14, pp. 289-304. (Bibliography.)
9. Chamberlain, A. F. *The Child: A Study in the Evolution of Man* (1900), pp. 173-211.
10. Clark, J. S. "Children's Drawing"; in *Educ. Rev.*, vol. 13, pp. 76-82.
11. Fitz, H. G. "Freehand Drawing in Education"; in *Pop. Sci. Mo.*, vol. 51, pp. 755-65.
12. Gesell, A. L., and Gesell, Mrs. B. C. *The Normal Child and Primary Education* (1912), pp. 125-43. (Illustrated.)
13. Götze, C. *Das Kind als Künstler*. (1898.) 36 pp. and 8 plates. (Bibliography.)
14. Groszmann, M. P. E. *Some Fundamental Verities in Education* (1911), pp. 59-118.
15. Hall, G. S. *Educational Problems* (1911), vol. 2, pp. 493-554.

Résumé and digest of all important studies to date.

16. Hicks, Mary D. "Art in Early Education"; in *Ped. Sem.*, vol. 2, pp. 463-66.
17. Hirn, Y. *The Origins of Art.* (1900.) 331 pp.
18. Hogan, Mrs. L. E. *A Study of a Child.* (1898.) 222 pp.
Contains an interesting series of a child's drawings.
19. Jordan, D. S. *The Book of Knight and Barbara.* (1899.) 265 pp.
Contains an interesting series of children's drawings.
- *20. Kerschensteiner, G. *Die Entwicklung der Zeicherischen Begabung.* (1905.) 508 pp.
- *21. Lukens, H. T. "Children's Drawings in the Early Years"; in *Ped. Sem.*, vol. 4, pp. 79-110. (Illustrated.)
22. Lukens, H. T. "Drawings in the Early Years"; in *Proc. N.E.A.* (1899), pp. 945-51.
- *23. Major, D. R. *First Steps in Mental Growth* (1906), pp. 47-71; 250-67.
24. O'Shea, M. V. "Some Aspects of Drawing"; in *Educ. Rev.*, vol. 14, pp. 263-84.
25. O'Shea, M. V. "Children's Expression through Drawing"; in *Proc. N.E.A.* (1897), pp. 1015-23.
26. Ricci, C. "The Art of Little Children"; in *Ped. Sem.*, vol. 3, pp. 303-07.
27. Rouma, G. *Le langage graphique de l'enfant.* (1912.) 288 pp. (Illustrated.)
28. Sargent, W. "Experimental Pedagogy of Drawing"; in *Jour. Educ. Psy.* (1912), vol. 3, pp. 264-76.
29. Scott, C. A. *Social Education* (1908), pp. 260-80.
- *30. Sully, J. *Studies in Childhood* (1895), pp. 298-398. (Illustrated.)
- *31. Tanner, Miss A. *The Child* (1915), pp. 465-86. (Illustrated. Bibliography.)
- *32. Tracy, F., and Stimpfl, J. *The Psychology of Childhood* (1909), pp. 166-79. (Illustrated.)
33. Watt, H. J. "Æsthetic Appreciation in Children"; in *Child Study* (1910), vol. 4, pp. 1-13.

CHAPTER IX

THE MORAL NATURE OF CHILDREN

Point of view. It is our purpose in this chapter to present the point of view of child morality which a sympathetic, first-hand study of children has developed; to suggest the moral and ethical bearing of a few typical studies of characteristic responses of children, upon which this point of view rests; to trace the evolution of moral ideas and of moral responsibility; and to suggest the relation of these facts to the shaping of conduct and character. In no field is it more essential to consider the biological, and especially the instinctive, factors in development. In chapter V we have shown that the child's first acts are instinctive, and that the nature and quality of these acts is predetermined by the organization of the nervous system which is an inheritance from his ancestry. Such acts presumably have, or once had, practical serviceability or they would not have become innate, but it is a mistake to attach moral quality to them. It is neither morally right nor wrong in the beginning for an infant to start when frightened, to recoil from pain, to cry when hurt, to take anything good for food when he is hungry, or to display violent temper when his instincts are opposed — it is merely natural. In short, responses that are wholly instinctive are devoid of moral quality so far as the agent is concerned. For every new voyager upon life's wide expanse, chart, compass, and goal are subjectively derived. For him one act is as good as another until experience and training teach otherwise. An infant is at first neither good nor bad, neither moral nor immoral, but *unmoral*. Moral ideas and ideals, and therefore moral obligation and responsibility,

grow out of experience reacting upon innate predisposition.

Among the responses which children instinctively make, some are beneficial, others detrimental; some are essentially social, others anti-social; some are pro-moral, others contra-moral. We who have the experience the child lacks have a right to term these natural acts *good* or *bad*; we have no right to call the child either. For him an *act* becomes good or bad when he recognizes its quality and its bearing upon his own welfare and that of others. *He* becomes good or bad when, recognizing the quality of acts, he chooses the right or the wrong.¹ In advancing this doctrine of moral evolution we do not deny an innate basis for the recognition of the moral qualities of acts. The capacity to attain morality is inborn, but the moral code and the ethical ideals adopted by any individual are the result of experience and training, of habit and volition. Children are born *with* a potential moral nature; they are born *into* a social order permeated with conventional and customary standards and ideals. The innate tendencies to social and moral responsiveness form the basis for acquirement of social manners, morals, and ideals. Children are by nature inclined strongly toward what is biologically right. The difficulties in the development of conventional morality are chiefly those inci-

¹ We are well aware that the natural or evolutionary view we here adopt has not been and is not universally accepted. Some have pictured childhood in the darkest of colors. The theological doctrine of total depravity, well expressed by St. Augustine, Calvin, Cotton Mather, Jonathan Edwards, and a host of other theologians, was long a dominant view. On the other hand, philosophers and poets, of whom Rousseau and Wordsworth are typical, with a penchant for idealization, have advanced the doctrine of original perfection portraying the essential goodness, purity, and glory of infancy "as it leaves the hand of the Creator." Neither of these views was based on a thoroughgoing study of the actual facts of child nature, which we hold to be the only basis upon which a correct view can be determined. We believe that the study of the actual facts of child development supports the evolutionary view.

dent to the fact that social far more than biological heritage now determines what is right and wrong.

Social nature of morality. In a very true sense morality is essentially social in origin and nature. Both individual and social morality are resultant in large measure from the evolution of the social instincts. A large part of conventional morality is the outgrowth of social customs. No other view makes intelligible the fact that moral standards, habits, and ideals vary with age, race, era, stage of civilization, and with the evolution of particular human institutions such as the institution of family relationships. The quality of early conduct is for the doer largely a matter of purely personal concern with, at first, no recognition of its effect upon others or of obligation to modify his behavior because of such effects. This is only another way of saying that the individualistic instincts dominate at this stage. So long as this remains true the very essence of morality is lacking. Conduct gets its moral quality chiefly from its effect upon others. The highest morality involves something of sacrifice of self and of selfish, instinctive interests for the good of the group of which one is a part. It is doubtful whether individual morality exists apart from recognition of its social bearing. The possibility of morality rests far more than is commonly recognized upon innate tendencies toward responses which gain social approval. If such tendencies were not stronger than those of an anti-social character, human society could not continue to exist. The principles of moral development and training are, therefore, to be based upon the facts of natural, instinctive behavior. For our present purpose the individualistic, social, and sex instincts are most significant. To trace the genesis of morality in detail in either the individual or the race would carry us too far afield. We must be content barely to indicate the course of evolution of individual morality.

In so far as the physical, mental, and temperamental equipment of children is hereditary, the foundation of character may be said to be laid before the child is born. The nature and degree of this hereditary factor will be examined more fully a little later. Individual and social factors begin the formation of habits of right conduct at least as soon as the child is born. Undesirable instinctive responses may be suppressed or inhibited by uniformly associating displeasure with them; desirable ones become habitual through encouragement and satisfaction. So from the very beginning of life, conduct is shaped for good or ill by influences outside the child himself as well as by internal factors. Long before the child himself has any other conception of the quality of his acts than that some bring pleasure and satisfaction, others displeasure and pain, much progress may be made toward laying the foundation of character in habit. Neglect, abuse, or ill health may, on the other hand, early undermine character, long before the child has come to the point of real responsibility for his acts. It is quite as true that the habits of childhood, for which the individual has little if any responsibility, determine character and volition, as it is that character determines the habits one shall or shall not acquire in maturer years. Good habits of eating, sleeping, playing, of responding to the will and pleasure of parents and others, established in infancy and early childhood, are almost a *sine qua non* in moral evolution preparing the way for self-control and self-direction in moral and ethical situations when real responsibility has had time to develop.

The psycho-analytic studies of Freud, Jung, and others have recently laid strong emphasis upon the moral bearing of the emotions of infancy and childhood. Jung (34, p. 66) clearly voices the view of the psycho-analyst when he says: "It is not the good and pious precepts, nor is it any other

inculcation of pedagogic truths that have a moulding influence upon the character of the developing child, but what most influences him is the peculiarly affective state which is totally unknown to his parents and educators. The concealed discord between parents, the secret worry, the repressed hidden state with its objective signs which slowly but surely, though unconsciously, works its way into the child's mind, producing therein the same conditions and hence the same reactions to external stimuli. . . . The father and mother impress deeply into the child's mind the seal of their personality, the more sensitive and mouldable the child the deeper is the impression. Thus even things that are never spoken about are reflected in the child." An appreciation of the full significance of such subtle influences in the formation of character would no doubt often explain many a moral failure at adolescence or later.

It is of paramount importance from our point of view that the relation of instincts, emotions, and early habits to character be clearly and firmly grasped before we attempt to determine by specific acts the moral culpability of a delinquent or the moral praiseworthiness of one whose conduct is pleasing. Our contention is that many instinctive, emotional, and habitual responses of early life are essentially non-moral in character, but that they are the basis of both moral and immoral tendencies in later years. To further normal physical, mental, and emotional development in infancy is therefore to further in reality moral evolution as well. Then, as consciousness of the moral qualities of acts enters more and more into choice; as conscience is born and comes to assume control of instincts and habits; as social ideals rather than personal desires become dominant motives; conduct becomes increasingly moral from subjective causes or, if these desirable ends fail to be attained in due time, we may justly charge immorality.

Stages of moral development. Moral insight and therefore moral responsibility normally increase with age and intelligence. It is a mistake to say that children are not morally responsible for their conduct until adolescence, as some writers seem to imply. It is rather a matter of the degree of responsibility that we may rightly expect at different stages. Moral responsibility is no more the development of a day or a year than is the strength and coördination of a man's muscles a matter that can be acquired overnight. There is much to indicate that moral development is marked by much the same stages and crises that characterize the development of the physical body. We shall not attempt to characterize in detail, as many writers have done, the stages in moral evolution from birth to maturity. In this as in other fields we encounter the serious difficulty that the stages are overlapping, so that a clear picture of any stage would be misleading and detrimental rather than helpful. If the fact of individual differences is clearly kept in mind, if we recognize that intelligence and stage of physiological maturity are here far more important considerations than chronological age, and if the lines are not drawn too closely between periods, there is a certain value in characterization of the moral nature by periods.

Infancy is essentially the non-moral stage in which conduct, whether self-initiated or imposed, is largely instinctive. Right and wrong is for the child determined at first almost wholly by the effect of conduct upon himself. Conscience and a sense of obligation are lacking entirely.

Early childhood may be spoken of as a preparatory stage during which habituation, imitation, and the development of the inhibitions, which in experience prove necessary, are laying a very essential foundation for true morality. The standards for conduct during this period are almost wholly external and arbitrary, from the child's viewpoint. Right

and wrong are largely what is permitted and what is forbidden rather than matters of principle.

In *later childhood* the moral discriminations are more and more aroused. Children now come to feel more or less of obligation in some fields of conduct, and do what they feel is right or avoid what is wrong because of this feeling. In other fields they may appear still wholly unmoral. Conscience is at times clearly active and at times apparently inoperative. The period is one of transition. Moral concepts are rapidly built up in fields where the child is brought frequently and actively into situations which call for moral response from him. On the other hand, he often is notably obtuse and has little or no conception of right or wrong in matters knowledge of which his immaturity and lack of experience have kept from him. The most deceiving feature of this period is the fact, often overlooked, that children acquire from their elders a large fund of "verbal morality" without any adequate appreciation of the nature of real morality with its self-imposed feeling of obligation. There is no more fruitful source of misjudgment of the moral capacities of children than the failure to make this distinction between verbal and real morality.

With the dawn of *adolescence* comes the birth of the real moral self. The period has long been characterized as one of "storm and stress." A lack of harmony between the instincts, impulses, desires, ambitions, and ideals of youth, and the moral and ethical demands of adult society, is to some degree inevitable. The approach of physical and physiological maturity brings with it new desires, interests, instincts, and capacities, as well as new feelings of moral obligation. The conflict between the promptings of instincts and those of conscience is often severe and long continued. If right habits have been early formed, if physical and mental development have been normal, and if environ-

ment does not impose unnecessary difficulties, the struggle usually ends in an established moral adjustment. Where these conditions are lacking the difficulties of such adjustment are greatly multiplied.

Normally *later adolescence* should see the harmonization of conflicting impulses, the settling of convictions, the willing assumption of all necessary obligations, the full development of moral responsibility. In the great majority of cases the final stones in the foundation of character are securely laid at this critical period that separates youth from maturity, but which is possessed of so many of the best traits of each.

Types of child behavior. In no field have the researches of the earlier child study been more fruitful than in that of the bearing of instincts and innate tendencies upon conduct. We cite here a few typical studies for their bearing upon the development of the moral nature.

Ownership. Kline and France (37) and Mrs. Burk (9) have well shown that the impulse to gather, acquire, or collect, by any suitable means, articles which satisfy wants or please the fancy, is instinctive. Children do not have to be taught to collect and hoard property. What is collected is of much less importance than the activity involved in collecting, and yet property intrinsically quite worthless is zealously guarded. This desire for personal ownership arises very early and is usually very strong, but respect for the ownership rights of others is a much later development. Children do have to be taught the property rights of others. Of 406 cases studied by Kline and France, eighty per cent "would beg, cheat, or steal to get the coveted article" (37, p. 263). Speaking of normal children under five years and of many others even up to fourteen or fifteen years, these authors say, "We have found that the desire to own is one of the strongest passions in child life; that selfishness is the rule;

that children steal, cheat, lie without scruple to acquire property; that they have no idea of proprietary right" (37, p. 266). This they hold to be natural. The complex conception of property rights as established by society is acquired slowly by the child, and arises out of experience of these rights in both self and others. Many instances are cited to show that respect for the rights of others had, in individual cases, arisen only with the full appreciation of the value to the individual himself of something into which he had put something of himself. A child who has never had anything which he could rightfully call his own is, on this principle, ill-prepared to appreciate the rights of others. The cure for theft and other forms of misappropriation of property is to no small degree the development of a keen sense of the significance and right of ownership.

The boys of the McDonough farm, as Johnson (33) tells the story in his *Rudimentary Society among Boys*, furnish an excellent illustration of the way the concept of property rights develops naturally among adolescents and the way in which respect for those rights establishes and maintains itself. The crude and primitive nature of the boys' laws and of the means of their enforcement clearly shows reasons for the inability of the boy of the city slums to make ready adjustment to the highly complex requirements of modern city life. Instinct and impulse are earlier and stronger than ideas and ideals of social responsibility. The fact that ninety per cent of the petty thieving of city boys' gangs is of things to eat and drink, and that many other cravings no less insistent than those of appetite impel to violation of the laws of society, should indicate both a condition and the remedy.

Miss Darrah (15, pp. 212 and 254) and others have found a natural increase in regard for law with age and experience. In early years the binding nature of law is not recognized in any abstract moral sense. In a hypothetical case, even

when the children were told what the legal penalty was, Miss Darrah found that at seven years only eleven per cent prescribed the legal penalty when asked what should be done. This increased to twenty-nine per cent at twelve years, and to seventy-four per cent at sixteen years.

All such studies as these clearly indicate the evolutionary nature of the moral ideas of children, and the place of instinct and habituation in the development of morality.

Curiosity. In curiosity we have another innate tendency which gives rise to certain undesirable traits. Smith and Hall (29, pp. 129-132) cite instances in which curiosity led to destructiveness in twenty-eight per cent of the 1247 children they studied. Investigation of the motives in all these cases is conclusive that "wanton destructiveness or carelessness played a very small part." On the whole, this tendency is a natural and irresistible one, closely related to constructiveness, and needs direction rather than repression. A certain amount of what seems serious violation of property values is in reality not rightly to be considered intentionally so, to say the least. Mrs. Schoff's (49) illustration of the homeless, friendless girl of eight years of age, who set fire to a house "to see the fire burn and the engines run," is typical of many. This child was in no sense "a prodigy of crime," as the papers stated, nor a "born criminal." If she had been either she would hardly be, as she is, a graduate of a normal school and an assistant principal of a Pennsylvania public school. Ignorance and neglect coupled with innate curiosity are quite sufficient as an explanation of her act. Similarly, many cases of apparent wanton cruelty are shown to be due, "not to any real impulse toward cruelty, but to ignorance and to an impulse which, when properly directed, is the prototype of scientific investigation" (29, p. 104).

Truancy. Custom and law regard truancy from home

and from school as a punishable delinquency, and it cannot be denied that if persisted in it is a fruitful source of delinquencies much more serious than the offense itself. It must not be overlooked, however, that Kline's (36) questionnaire studies, and the more recent one of Davenport (16), have shown that nomadic tendencies have a very strong instinctive and hereditary basis. At certain seasons and ages there surges through the veins, of the boy especially, a strong impulse to throw off restraint, to strike out for self, to see the world, to slough off all conventional and usual forms of social restraint and wander alone, or with some congenial companion, often to drink in from Nature herself what the tingling senses call out for. The *Wanderlust* is one of the most natural of impulses. Were it not for what it leads to through idleness and temptation, the impulse itself might often be followed with small danger of permanent injury, and frequently with most beneficial results. Kline's study of the motives for truancy reveals little intent toward wrongdoing in such breaks from the restraint of home and school. In many cases the serious charge must be brought against the home and the school, and against society for failure to provide normal and harmless, not to say educative and helpful, avenues for the exercise of the innate tendencies which lead to truancy. Many of these underlying impulses are not only harmless, but useful and desirable. The doctrine of catharsis can be helpfully applied in this connection. Some normal outlet for the impulses of this class seems the best means to ultimate control and taming of refractory racial impulses. Punishment and repression often prove to be most unsatisfactory remedies. There is certainly nothing essentially wrong in the act itself. Puffer (47) has many helpful suggestions which, if heeded by parents and teachers, may turn this impulse to valuable educative and normalizing ends.

Children's lies. Hall's (27, vol. 1, pp. 345-87) extended and careful study of children's lies reveals clearly the evolutionary nature of veracity. It seems unquestionably certain that many of the early falsehoods of children are totally devoid of moral culpability. In the lie of imagination the child himself is deceived. In that of selfishness his self-preservative instincts so strongly dominate that, until trained to bear the consequences of his own acts, he cannot be held to strict accountability. Hall summarizes the results of numerous experimental studies of the psychology of report which seem to show that young children are lacking in those mental capacities which make it possible for them either to tell a literal truth or falsehood. Several of the German writers seriously question whether children can tell real lies before four years of age. The concept of truth has first to be developed, then the feeling of obligation to tell the truth. Neither is innate, and in reality it would be somewhat startling to find a child who from the beginning could and did tell the literal truth from a sense of obligation.

Obstinacy and disobedience. Dr. Theodate Smith (54) made a careful questionnaire study of 1418 cases of obstinacy, willfulness, contrary-mindedness, and disobedience, which throws some interesting light upon the evolution of self-control and social self-direction. She is convinced that "some cases of obstinate and persistent disobedience undoubtedly have their origin in strong instinctive desires which the child neither understands nor knows how to inhibit" (p. 29). Some cases are clearly chargeable to physical conditions, such as malnutrition, eye-strain, fatigue, and the like. Extreme forms are often found with the feeble-minded, which seems to indicate that intelligence is an important factor in the development of obedience and self-control. Some cases are clearly due to injustices and arbitrariness on the part of older persons. From consideration

of all the extremely varied and highly complex bodily and mental states involved in obstinacy, the writer concludes that obstinacy is due to weakness and not, as is often popularly supposed, to strength of will (p. 44). Hereditary factors, particularly instinctive ones, are complicated with immediate and remote environmental factors in ways which make adjustment extremely difficult for untrained human nature. Occasional attacks of obstinacy and disobedience are normal for all healthy children, since infancy and childhood are essentially egoistic and dominated by emotions, impulses, and instinctive desires which often overbalance considerations of social obligation, expediency, and even actual desire to please and obey another. In a very true sense the capacity for obedience to authority and law is a resultant of will training. For real self-control a strong will properly trained is essential. The weak-willed may learn conformity to authority, but he learns self-control with difficulty. This is what Sully (56) means when he asserts that the most rebellious children are biologically the best. The same conclusion may be drawn from Bohannon's (5) contention that timidity and weakness are associated with exceptional obedience of a formal sort, but that exceptional obedience of a real, self-initiated sort usually issues from exceptional courage and strength of will. The child who has learned self-control and self-direction has little difficulty in adjusting himself to conventional moral ideas and ideals when these are intelligibly presented; one who has failed in these virtues falls in time of stress.

The point we wish to emphasize in this connection is the evolutionary nature of these virtues and their relation to the ultimate development of character. Self-mastery hardly comes without some self-assertion; a consciousness of power, capacity, and strength can hardly be realized without the matching of self against the will of another. A feeling of the

justice, necessity, and reasonableness of law grows out of the experience of insufficiency of self, and conformity to law ought to and usually does result from full appreciation of social dependence and accountability. All this, however, requires time and training in control of instincts.

Teasing and bullying. Burk's (8) study of these troublesome and often reprehensible tendencies clearly indicates that they are no less natural than truancy, obstinacy, or untruthfulness. The dynamic, inquiring disposition of childhood so essential to cultivation of sensory and motor capacities often leads inevitably to unintentional as well as to intentional abuse of the rights and feelings of other persons and those of animals. Few traits of childhood are more troublesome and distressing to parents and teachers than those shown by the tease or the bully, and yet Burk's study of many concrete cases absolves a large percentage, of younger children at least, from any great degree of culpability for the pain and injury which their acts often cause. Curiosity, ignorance, and uncontrollable impulses are here again often sufficient explanation. The tease and the bully are more often in need of moral enlightenment and actual physical and mental experience of personal discomfort and pain as a means of acquiring fellow-feeling than they are of retributory punishment, imposed, perhaps, without regard to the nature of the offense which may have been committed quite without intent of wrong.

Imitation. Many studies of infancy and childhood show that the innate tendency to imitate is one of the most far-reaching of all the native capacities for good or bad conduct. Children do what they see others do. For years they have no higher criterion of right and wrong than the example of those about them. Much of conventional etiquette, custom, manners, and even what we rightly consider habits of very vital moral concern, is acquired by the child imitatively long

before its moral quality is appreciated. On the other hand, much which tends strongly in the direction of serious immorality is similarly acquired in perfect innocence of wrong. For example, how is a child to know that it is wrong to steal coal from the railroad tracks if he sees every one doing it, and is commended by his parents as a good boy because he keeps the coal box full? How is a child to learn to speak the truth when he hears his father boast of business success based upon falsehood, or sees his mother dodge some unpleasant social obligation by a plain falsehood unblushingly uttered?

Partridge (46) finds that many times curiosity and the imitative impulse, coupled with the gregarious instinct, lead to the drink habit. The boy's desire to smoke almost universally arises from the same impulses. Recognition of the physical and moral effects of habits in these matters cannot be expected of children in the absence of direct instruction, and considering the strength of the impulses underlying them cannot be considered serious moral offenses in the immature and uninstructed.

This whole group of studies and many more which could be cited from the early literature of child study, whether we look upon them as thoroughly scientific in method and results or not, have thrown a flood of light upon the groundwork and "raw material of morality" which cannot be lightly passed by if we wish to know the steps by which the child attains conventional and real morality. In the instincts and their proper treatment lie the clues which the teacher must carefully study and thoughtfully follow out in setting the moral and ethical goals toward which moral training must aim. Many of them are non-moral; some, due to the vast and sudden accumulation of social heritage, are anti-social or contra-moral, but withal natural and inevitable. Without them, however, the building-up of habits and ideals

would be even more difficult than it is with them. Man's long and eventful past cannot be ignored in the moulding of his present and future character.

SUMMARY

1. Children are not moral or immoral, but non-moral to begin with.
2. The basis of both moral and immoral conduct is to be found in the instincts.
3. The development of morality is largely dependent upon the capacity to appreciate and react to moral ideas and ideals. This capacity is inborn, but requires development. Feeble-mindedness seriously impairs this capacity and is therefore a prime factor in delinquency.
4. Acquired physical defects standing alone are a less important factor than many have tried to make out.
5. Hereditary defects, other than mental deficiency, are by no means a negligible factor, although not a major one.
6. Morality is essentially social in origin and significance and develops best in social situations.
7. The stages of moral development can be only roughly marked off because morality depends much more upon intelligence and training than upon age.

QUESTIONS AND TOPICS

1. Observe and attempt to analyze several cases of extreme obstinacy. Consider exciting causes, physical and mental symptoms, instinctive elements, motor control, etc.
2. Collect instances of untruthfulness due to imagination, to selfishness, to the impulse of self-preservation, to the impulse to shield another, to faulty home training, to "natural perversity."
3. Collect instances among young children of misappropriation of things of value belonging to others. Determine in which cases moral culpa-

bility can be rightfully charged and suggest appropriate treatment of each case on its merits.

4. Get first hand information about several cases of truancy. Consider the factors of age, season, home surroundings, interests, physical condition, school history. Find out where the time was spent and what was done. What blame do you attach to the child in each case and what remedy do you suggest?
5. Cite instances of curiosity which led to unintentional destruction of property or harm or annoyance to other persons.
6. Gather instances of disobedience due to a weak time sense, to the impulse of egoistic self-assertion; to the dominance of other strong instinctive tendencies. Prescribe appropriate treatment in each case.
7. Collect instances of teasing and bullying that have been successfully cured and give details of the means by which it was done.
8. Give a list of moral offenses which may be charged largely to imitation.

SELECTED BIBLIOGRAPHY

The bibliography for this chapter is combined with that at the close of chapter x.

CHAPTER X

JUVENILE DELINQUENCY

STILL further to illustrate our view of the evolutionary nature of child morality we shall turn, in this chapter, to a somewhat detailed study of juvenile delinquency. This is the pathology of morality, and just as it has been found that physical and mental pathology have given us some of our best insight into what is physically and mentally normal, so we believe a study of delinquency holds many suggestions of value for us in our attempt to understand the nature of child morality and the means of its development.

Definition. The term *crime* has almost passed from use as a designation of the anti-social and immoral acts of children under sixteen or seventeen, — in California even twenty-one years of age. [The milder term *delinquency* has been adopted in most of our juvenile court laws. Under the California law a child guilty of law-breaking is designated merely a “ward of the court,” so that for these years the recognition of moral immaturity has gone so far that *dependency* and *delinquency* are in effect almost synonymous terms. In the Colorado law, which has been a model for many others, the term *juvenile delinquent* is defined so broadly as to insure the court jurisdiction in every case in which a child’s future welfare is at stake. Children of certain ages may be legally declared *delinquent* if it is clear that they are in danger of drifting into crime by reason of bad associates, idleness, truancy, evil example and environment, aimless wandering about the streets at night or about railroads, immoral conduct, and the like, as well as for the commission of overt violations of state, city, or village laws

or ordinances. In no case is such a child called a criminal or treated as such. (This radical change in laws regarding childhood and youth, which belongs almost wholly to the twentieth century, evidences a revolution of attitude regarding the moral nature of children. The doctrine of innate goodness or innate badness of human nature has been discarded for the doctrine of moral evolution. The assumption of law is that the moral nature and moral accountability have to be developed, and that till they are it is a misuse of terms to designate even an overt anti-social or immoral act a crime or the actor a criminal.)

Causes. The underlying cause of juvenile delinquency, the explanation of the greater prevalence and wider distribution of offenses among the young, and the relative and absolute increase in the number of such offenses which statistics the world over have shown in recent years, is the *moral immaturity of children and the increasing complexity of modern social and industrial life*. Apart from such general statement, all the numerous efforts of the past forty years to center upon some one chief cause seem doomed to failure. The net result of these efforts has been to impress the extreme complexity of the problem of causation. To hold with Lombroso and the Italian school that most true criminals are a "born" anthropological type is less satisfying now as an explanation than at any time since 1876, when the theory was first proposed. To hold with Morrison, Travis, with the sociological school generally, with the majority of social workers, and with probation officers as a class that the defective home, bad environment, or social and economic conditions are the chief cause, needs specification. To try to prove that imitation, or alcoholism, or epilepsy or feeble-mindedness, physical or psychic atavism, or any other of the known contributory factors, is the chief one, as has often been done, seems to the author to lay one liable to the

charge of ignorance of the fact that the causes are as complex and as varied as human nature itself. There is no one cause. Nothing is clearer than that *every delinquent is an individual problem* whose case deserves to be studied as such. He and not merely his offense must be studied. Healy (31) has once for all made this clear. The causes of delinquency vary with age, sex, intelligence, with the individual, with climatic, seasonal, and geographic factors, and with environmental conditions. Here again we are faced with that interminable question of heredity *versus* environment, discussed in an earlier chapter. There is the widest difference of opinion on this question as well as on that of the relative proportion of delinquency chargeable to each of the specific hereditary and environmental factors. We shall try in the brief space at our disposal to present something of the consensus of view among the more careful scientific students of the subject as to the etiology of delinquency, in the hope that those who desire to aid constructively in its prevention may better understand the nature of their problem.

Hereditary causes. Lombroso and his followers believed that they had discovered an anthropological type marked by definite, atavistic, physical stigmata, chiefly of the head and face, which marked the criminal as an individual who had reverted to or been arrested in a stage of development belonging to an ancient human or pre-human type. The physical stigmata oftenest mentioned were: thick head of hair, thin beard, large cheek-bones, asymmetrical skull, anomalies of ear, eye, nose, palate, teeth, feet, fingers, and the like. The person showing five of these traits was thought to be certainly a potential if not an actual criminal. Gara-falo (64, p. 62) believed that it was not only possible to pick out the criminal from among normal persons eighty times out of one hundred, but even to tell what crime he had

been or would be guilty of. Lombroso's was one of the first theories to apply the evolutionary principle, so that it is not surprising that he also took the contra-moral instinctive tendencies of children as evidence that "the germs of moral insanity and crime occur in normal fashion during the first years of man's life, just as in the embryo we are constantly meeting with forms which, in the adult, are monstrosities" (10, p. 365). Unfortunately for the theory, Lombroso's data came chiefly from study of adult Italian criminals, and confirmation of it is lacking, especially with the young. Travis (64), after several years of study of the literature and statistics of crime, supplemented by extensive first-hand study of institutional criminals in this country and in Europe, finds the Lombrosian type very rarely. In one institution only one such case was found among three hundred inmates, and he was Italian. It has also been shown that these stigmata are quite common with the insane who are not at the same time criminal. Travis's (64) wide observation brought the conviction that the possession of two or three such traits is not at all uncommon among normal individuals. Recent studies of mental defectives strongly suggest that the picking out of all feeble-minded criminals would probably result in leaving the large balance almost if not entirely as free from such defects as average normal persons. This would undoubtedly be still truer in the case of children. Many feeble-minded delinquents and criminals do approach the Lombrosian type.

For the theory of psychic atavism the case seems somewhat stronger. Excellent presentations of this theory can be found in the studies of Swift (57) and Dawson (17). The absence of clearly defined moral ideas, habits, ideals, and feelings of obligation in childhood put it on the plane of primitive man. This, together with the racial heritage of instincts, many of which must be entirely eradicated, or at

least radically modified, to meet the requirements of modern civilized society, makes the child a potential delinquent if those influences which further moral evolution are lacking. Swift, by a rather limited investigation of the boyhood of highly reputable adults, tries to show that all children pass through a delinquent stage. His conviction is that reform-school boys with few exceptions "are quite representative of the average active, normal boy," and that the unbiased investigator must be convinced that, "after all, probably the only reason why he and his boyhood associates did not graduate from the same sort of institution was the difference in their environment" (57, p. 33). For him "the so-called criminal instincts of children are the racial survivals of acts that in past ages fitted their possessors to survive," and "a period of savagery, or semi-criminality, is normal for all healthy boys" (p. 78). He believes that the fact, borne out by statistics, that of children whose parentage is known to be bad and whose environment has been almost everything it should not have been, eighty to eighty-five per cent grow up to be young men and women of good character after they are placed in better surroundings proves his contention. Bonger (6, p. 378) takes much the same view when he says, "from a biological point of view almost all crimes must be ranked as normal acts." Killing, theft, robbery, rape, and the like were once natural, common, and biologically normal acts. It was only as such acts evoked the moral disapprobation of society that they became immoral. Not a few other criminologists have taken this view that the criminal is a type of individual whose psychic or moral evolution has been arrested at a stage representative of an earlier human type. On this view the problem of delinquency becomes that of curtailing, controlling, and redirecting of the racial heritage by sane, wise, and rapid induction into the social

heritage of the present, and the avoidance of either physical or mental arrest of development.

Instincts and crime. The natural instincts and the ignorance due to the moral immaturity of children are an exceedingly important causative factor. Jane Addams speaks of delinquency as "instincts gone wrong." The undeniable right and necessity for play, of which we have already spoken, denied its legitimate opportunity all too often leads to natural and unintentional violations of city ordinances, the first arrest, incarceration with those already delinquent, and on to confirmed delinquency. A police officer in Chicago testified that the opening of one of the great public playgrounds of that city reduced delinquency in its tributary district by more than thirty-three per cent in a single year, and saved no less than sixteen lives besides. Jacob Riis, in his various books on the life of New York's East Side, has clearly shown that, when legitimate play facilities are lacking, the quest for excitement and adventure, which is natural and normal in all healthy boys, leads again and again to delinquency. Mrs. Barnett (4, p. 12) reports that "during 1911, 605 children were brought before the Birmingham Juvenile Court for non-indictable offenses including: 132 playing football in the streets, 43 gambling, 34 willful damage, and 64 disorderly conduct." Most of this delinquency presumably could have been prevented by legitimate opportunity for the outlet of normal instinctive tendencies. The *West Side Studies* (23), as well as the police and court records of every city, show the same. Consider the relation of normal instinctive tendencies to the following list of charges quoted by Jane Addams (1, pp. 55-56), just as they appeared in order on the records of the Juvenile Court of Chicago:—

1. Building fires along the railroad tracks.
2. Flagging trains.

3. Throwing stones at moving trains.
4. Shooting at the actors in the Olympic Theater with sling shots.
5. Breaking signal lights on the railroad.
6. Stealing linseed oil barrels from the railroad to make a fire.
7. Taking waste from an axle box and burning it upon the railroad tracks.
8. Turning the switch and running the street car off the track.
9. Staying away from home to sleep in barns.
10. Setting fire to a barn in order to see the fire engines come up the street.
11. Knocking down signs.
12. Cutting Western Union cable.

In such offenses as these, racial heritage and unsuitable environment unite to bring about the moral degradation of boys and girls.

Feeble-mindedness and crime. A great number of recent studies has shown that feeble-mindedness is one of the important causes of permanent delinquency. Goddard (21) has recently shown that mental defect is hereditary in perhaps sixty-five to seventy-five per cent of the cases. If his estimate is correct, feeble-mindedness is largely an hereditary factor. Woods (68, p. 263), ten years or more ago, reported that "there is a very distinct correlation in royalty between mental and moral qualities." Morrison, in 1897, stated that "at least a third of these juveniles are below the average healthy standard in general mental power" (44, p. 20), although he had no accurate tests upon which to base his estimate. Just what part mental defect plays in the production of crime we are only beginning to learn owing to the recency, and still tentative nature, of the means for its accurate measurement. The most careful studies of this matter by the best means available — the Binet-Simon and similar tests of intelligence — find the percentage of actual feeble-mindedness among delinquents very much larger than among children in general. Unques-

tionably the percentage was placed too high in the studies of five years ago, but to place it at not less than twenty-five to thirty for non-selected delinquents of the juvenile court and institutional classes will certainly be considered quite conservative. This, as compared with one or two per cent among the ordinary school population, as determined by the same tests, gives some idea of the importance of this factor alone.

In the accompanying table (on page 234) we list the findings of a few of the more careful recent studies of the mental condition of delinquents.

It will be noted that there is wide variation in the percentage of mental defectives found among delinquents by various investigators. This is due to a lack of uniformity in the tests used, to a lack of agreement as to just what degree of defect shall be termed feeble-mindedness, to a lack of uniformity of procedure and of skill in conducting the various studies, to the fact that some groups tested are selected and others non-selected, that some were children and others adults, to the possible sex difference, the small number of cases in some studies, and perhaps to other variable factors. We are just at the point now of determining the effect of these variable factors, and should within a few years have very definite information on all these matters. We shall then be in a position to estimate pretty definitely how much of delinquency is primarily due to feeble-mindedness alone.

Significance of feeble-mindedness. Courts of law and the public generally are just beginning to recognize the bearing of feeble-mindedness upon moral accountability, education, and training. In his book, *The Criminal Imbecile*, Goddard (22) presents an analysis and discussion of three typical cases, the first in which the results of diagnosis with the Binet-Simon tests were admitted in evidence in

TABLE VIII
INTELLIGENCE TESTS OF JUVENILE DELINQUENTS

<i>Observer</i>	<i>No. cases</i>	<i>Sex</i>	<i>Percentage feeble-minded</i>	<i>Classes tested</i>
Goddard and Hill	56	F	66 (?)	Reform School
Goddard	100	...	66	Juvenile Court
Fernald, G. G.	100	...	25	Reform School (Mass.)
Dewson	1186	F	28	Industrial School (Pa.)
Sullivan	114	F	32 (?)	Prison (England)
Bowers	100	...	23	Prison (Ind.)
Hickson	245	M	87	Court (Chicago) (Selected from 600 cases)
Renz	100	F	36	Reform School (Ohio)
Healy	1000	M & F	10	Psychopathic Inst. (Chicago) (Selected recidivists)
Aschaffenburg	495	...	13.5	Reform School (Germany)
Monkenmoller	134	M	50	Neglected (Berlin)
Pintner	100	M & F	46	Court (Columbus, O.)
von Klein-Schmid	1000	...	50	Prison (Jeffersonville, Ind.)
Terman and Williams	150	M	28	Industrial School (Cal.)
Fernald, G. M.	135	F	33	Industrial School (Cal.)

this country. The case of Jean Gianini, indicted for the murder of his former teacher, is the first in which the result of such diagnosis has resulted in acquittal. The verdict was, "We find the defendant in this case not guilty as charged; we acquit the defendant on the ground of criminal imbecil-

ity" (p. 2). This verdict marks an epoch in criminal procedure in that it "recognizes that *weakness* of mind, as an excuse for crime, is of the same importance as *disease* of mind" (p. 2). Few judges or juries have as yet taken the stand of those in the Gianini case. Within a year Charles Oxnam, seventeen years of age, but declared by eight physicians and four psychologists, of whom the writer was one, to be of not more than eight- or nine-year intelligence, has paid the life penalty at the hands of the State of California for a murder for which his mental defect made him at least as irresponsible as a child of nine, working under the direction of a more intelligent accomplice. Mental defect does not mitigate the seriousness of the crime. Those who would prevent the legal murder by the State in such cases wish merely to save the State the humiliation of taking the life of irresponsible children whose crimes are a natural result of the failure of society itself in allowing the unrestricted reproduction of mental defectives whom, when born, it fails to safeguard against almost inevitable delinquency of a more or less serious sort. They would arouse the State to its obligation to protect both itself and these unfortunates by humane and effective measures such as are now known.

Why does feeble-mindedness so strongly predispose to delinquency? Terman (61, p. 35) answers that true "morality depends upon two things: (a) the ability to foresee and to weigh the possible consequences for self and others of different kinds of behavior; and (b) upon the willingness and capacity to exercise self-restraint." It is just these capacities which the feeble-minded lack far more than children of average intelligence. Moral judgment, inhibition, and resistance to suggestion are "functions of intelligence" far more than they are of chronological age. Goddard (22, v. 95) expresses his conviction, "born of a study of normal children and also of mental defectives twelve years and

under in mentality, that persons of this mentality do not know much about right and wrong. They act upon impulse and upon instinct, without very much thought." This fact is often not recognized by the superficial observer because he fails to make the distinction Goddard clearly makes between verbal morality, learned parrot-like, and that deep-seated conviction of wrong which alone grows out of a full normal and intelligible experience and which does not come till the years of adolescence. The imbecile may know the nature of his act — that is, what he is doing — without knowing fully its *quality*, to understand which he must "know all of the elements, forms, or modes of being or action which seem to make it distinct from all other acts . . . know it is unjustifiable" (pp. 96-98). Goddard's (22) description of three typical cases of criminal imbecile murderers, cited above, illustrates three ways in which such persons fall into crime. One knew what he was doing, but did not know the quality of his act, and lacked the necessary capacity for inhibition under a strong instinctive-emotional complex. The second knew the nature and possibly the quality of his act, but had not the power to resist the subtle suggestion of his accomplice. The third knew both the nature and quality of his deed, but failed in capacity to think the whole situation through in a reasonable and intelligent way. This does not argue that all murderers are lacking in intelligence, for normal intelligence must also be accompanied by normal will and emotion, but does clearly show that lack of intelligence makes the individual much more likely to commit crime, especially under stress. Such persons fail to learn the lessons which persons of normal intelligence gather readily from the numberless common incidents of daily life.

Other hereditary causes. The total contribution of heredity has not yet been clearly made out. Recent stud-

ies indicate that insanity, epilepsy, and kindred defects are hereditary, and that they predispose to delinquency. Other hereditary physical defects, especially neuropathic conditions, results of serious alcoholism of parents, hypersexual tendencies, unfortunate temperaments, and perhaps others are also by many held to be factors which complicate the problem of moral evolution and complete socialization (31, p. 201). Eugenics has no more important problem than that of tracing this relationship more definitely.

Environmental causes. The environmental causes are so numerous and so interrelated that we shall be unable to do more than note the bearing of a few of the more important ones. Such vivid pictures as those given us in the *West Side Studies* (23), and those of Breckenridge and Abbott (7), are almost convincing enough to bring the conviction that the chief cause of delinquency is, as Mrs. Schoff (49), Travis (64), and many others have maintained, the defective homes from which children come, except that one is driven to inquire why there are so many defective homes. When such inquiry is made, other important causes come to light. Bonger (6), who reviews all the important literature on crime and presents no end of statistical material bearing on all phases of the subject, makes a strong case for his contention that "economic conditions occupy a much more important place in the etiology of crime than most authors have given them" (p. 667), and that "the part played by economic conditions in criminality is preponderant, even decisive" (p. 669). Poverty and lack of employment, inadequate pay, and unfavorable conditions under which work is done, all tend to create unfit home conditions. Economic stress leads to child labor with its attendant evils, which predispose to delinquency. Clopper (11, p. 137) quotes from the *Report on the Condition of Woman and Child Wage-Earners in the United States*,

authorized by Congress in 1907, to show that in seven of our largest Eastern cities child workers committed, in 1907-08, more than sixty-two per cent of all offenses of children between six and sixteen years of age. The report adds: "When it is remembered that a majority, presumably a large majority, of all children between these ages are not working, this preponderance of offenses among the workers assumes impressive proportions" (p. 160). Bonger (6, p. 408) presents statistics from the Netherlands, extending over a period of six years, which show that "among the young delinquents there are two or three times as many persons following a trade as among non-delinquents." The percentage of sentenced children who practiced trades ranged from a little less than forty-six to more than fifty-one per cent of all the delinquents. This is a most striking commentary on the effect of child labor upon delinquency. The Chief Constable of Edinburgh, Scotland, is credited with the statement that "two thirds of the children passing through the courts during the last thirty years have been associated with street trading" (4, p. 13). It is universally agreed that among the trades the street trades are most productive of delinquency among boys, approximately sixty per cent of the working delinquents being engaged in such trades (11, p. 137). Of these, newsboys form by far the largest proportion. Nearing (11, p. 135) says: "Whatever the cause, the effect on the newsboy is always the same. He lives on the streets at night in an atmosphere of crime and criminals, and he takes in vice and evil with the air he breathes. . . . The professional newsboy is the embryo criminal." There are many causes for the relation between child labor and delinquency which cannot be dwelt upon here. By no means least important is the premature contact with the evil associations and the temptations of the street, factory, and workshop, with loss

of the restraints of home and home training so much needed in formative years. The early assumption of responsibilities unsuited to young shoulders is also very detrimental. All the many careful studies point in one direction — physical, economic, and moral deterioration are, if not inevitable, at least, the common result.

Jane Addams (1) has shown clearly, out of her rich experience, how the factory system dominates many quarters of the city; how it has outrun all educational and social arrangements; how oftentimes the spirit of youth stands it patiently for a time, and then suddenly breaks violently away from its monotony and restraint, its soul-repressing and soul-destroying power. At this point the youth either throws up his job, vowing never to enter the factory again, or he changes from occupation to occupation for novelty's sake, mastering nothing, and sinking rather than rising in the scale. Under such conditions occasions favorable to delinquency are multiplied many-fold, and often the delinquency results from sheer desperation, in "quest for adventure" of a legitimate sort for relief from the over-stress of industry. The unsuitability of child labor as usually conducted should be clear from our earlier discussion of the need for and values of play, especially in the light of Patrick's theory.

On the other hand, the old proverb that "idleness is the mother of all vices" finds much confirmation. The period of greatest frequency of juvenile delinquency corresponds closely with the age at which the majority leave school and either remain wholly idle, or for several years work at odd jobs or go from job to job, with much idle time on their hands. No other cause has been more strongly stressed. After thirty years of experience, Mr. Andrew Drew, of the "Industrial Committee of the London School Board," says, "truancy is to be credited with nearly the whole of our

juvenile criminality." This statement is, of course, entirely too strong, but many others have been driven by observation to the view that truancy is in many cases the first step in juvenile delinquency. Morrison (44) is not far wrong when he says, "a disposition to evade parental and scholastic authority, showing itself in vagrant habits, may be considered as being in many cases the initial step toward the complete evolution of an anti-social life." So close is the relationship that truancy, vagrancy, and even idleness are, under some of our juvenile laws, themselves delinquencies. The truant impulse and that to commit delinquencies of a more serious sort both have their roots in the same instincts. Opposition to child labor does not require that one advocate the rearing of children in idleness. Nothing is more detrimental than total freedom from responsibility during childhood. Suitable employment at school and at home, or even outside of either, may be something quite different from child labor as commonly understood. Suitable summer courses in the public schools located among the laboring classes of Los Angeles have had a definite and measurable effect in keeping down the usual increase of delinquency during vacation periods, according to the testimony of both school and court officials. Successful efforts in securing suitable positions for pupils has been of further help in the same direction. All schools could perform an important service by keeping in touch with their pupils after they go to work and rendering them such aid as the vocational guide is now beginning to offer.

The gang. Jacob Riis in several of his books, Goldmark (23), Puffer (47), and many others have presented convincing proof that the boy's gang is a fruitful source of delinquent tendencies. The gangs of both the East and West Sides in New York have been the terror of citizen and policeman alike, committing many depredations, a majority

of which go unpunished. With the backing of his gang many a boy commits anti-social acts he would not think of attempting alone. Much as the pack reinforces the courage of the wolf, the gang does that of the boy. In spite of Puffer's well-established contention that the gang may have more virtues than vices, a bad environment furnishing little or no legitimate outlet for its energies makes it a potential power for evil. Puffer himself (p. 40) found seventy-four per cent of his sixty-six gangs had engaged in predatory activities. The relation of these activities to racial instincts seems clear in his statement that "probably nine-tenths of the objects stolen by youths before the age of sixteen are things to eat" (p. 105). Some juvenile judges aim to remove the delinquent from the influence of his gang or to break it up as the first step in reformation. Judge Lindsey is a notable exception in that he works with and through the gang for its reformation. His notable successes commend his theory, though it seems doubtful if many could successfully follow his example.

The responsibility of society for delinquency cannot be easily overrated. Again and again it has been shown that children whose delinquencies were of the mildest sort, and even those innocent of wrong, have been confirmed in delinquency by the unwise, ignorant, even criminal treatment they have received at the hands of the law. Many a boy, before the day of the juvenile court laws, has received his initiation into a criminal career from real criminals with whom he was forced to associate in jail, reform school, or prison. Judge Lindsey and other pioneers for the Juvenile Court made much of their appeal to public interest and public conscience by merely relating actual instances of such cases. The epigrammatic statement of Lacassagne, that "societies have only the criminals they deserve" (10, p. 358), has much truth in it. Tarde, in his

extensive studies of imitation and suggestion, has also given much substantiation to the view that crime is "pre-eminently a social phenomenon." If environment were always at its best, virtue would be quite as common, yes much more common, than delinquency is in a bad environment. As Bonger (6, p. 535) puts it: "He who is born with weak social instincts runs more *danger* of becoming a criminal. But the *certainty* that he will become such does not exist — that depends upon the environment."

Physical defects and delinquency. Many attempts have recently been made to show a close correlation between physical defectiveness and delinquency. Numerous cases have been cited in the literature in which the relief, afforded by dental and surgical aid, from nervous tension due to impacted teeth, eye-strain, or pressure on brain tissue, or the improved physical health and growth due to the removal of diseased adenoids or tonsils and the like, has worked a moral transformation in the patient. It is not denied by any one that both defects causing weakness and those causing irritation are factors in the causation of delinquency, but there has been a tendency to overestimate their significance. As we point out elsewhere, physical anomalies are unusually common with mental defectives, but for the rest there is much support from recent statistical studies for the view of Goring (31, p. 370), that "the physical and mental constitution of both criminal and law-abiding persons of the same age, stature, class, and intelligence are identical." Healy (31, p. 216) found defective vision a major factor in ten per cent of his cases, defects of hearing unimportant, of teeth unestablished, of the nose and throat a probable factor, but one that has been much exaggerated. Defects of nutrition, of the nervous system, and other minor physical irritations he also finds to have some slight causative effect. He finds syphilitic infection,

which is exceedingly prevalent with immoral girls and women, an important cause. It leads to paresis, and that predisposes to crime. Perhaps no physical condition may be considered more important than under-nourishment, although it is difficult to separate, as Healy (31) has shown, from the other effects of poverty, alcoholism, etc. Oppenheim long ago stressed the factor of nutrition as a safeguard against physical and moral arrest. School health work everywhere has made it clear that malnutrition, if not the major cause of physical defectiveness and physiological retardation, is at least one of the major causes of these conditions, both of which are measurably unfavorable to moral development.

Age and crime. Visitation of courts where offenders of

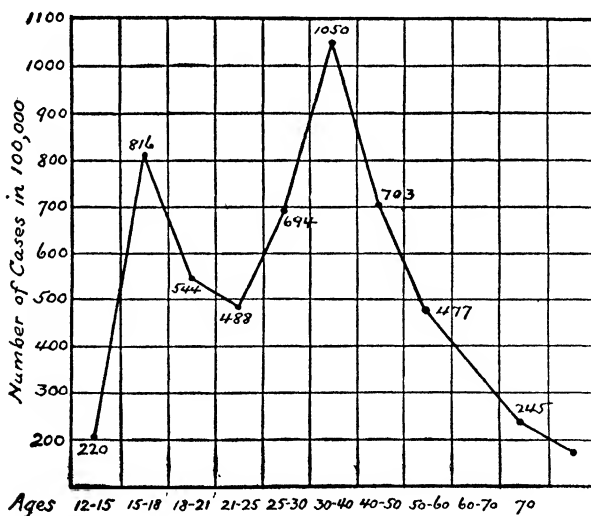

FIGURE 11. RELATION OF AGE AND CRIME

From Hall's *Educational Problems*, by permission of D. Appleton and Company, New York.

all classes and ages are tried and convicted, of penal and corrective institutions, and the study of criminal statistics, always leaves the investigator with a strong sense of the youthfulness of the offenders. Crime and delinquency not only begin in childhood and youth in almost all cases, but reach their two culminating points, one in the middle 'teens, the other before the prime of life, usually between twenty and thirty. Few are found in the latter group who

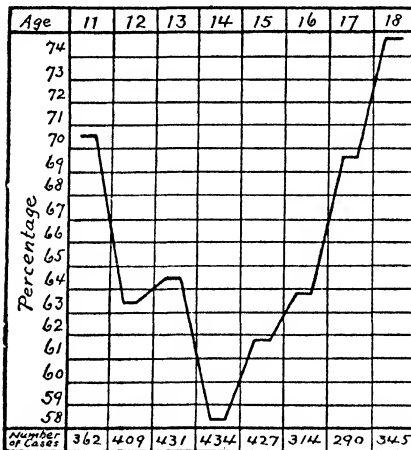

FIGURE 12. PREVALENCE OF GOOD CONDUCT AT DIFFERENT AGES

After Marro.) From Hall's *Adolescence*, vol. 1, by permission of D. Appleton and Company, New York.

were not earlier in the other. "Cady, averaging all the available data, concludes that the average age of the delinquent boy is 14.09 years, and that of the delinquent girl 14.71 years" (64, p. 151). Hall (25, vol. 1, p. 333), from the Census of 1890, finds the greatest number of offenses occurred at sixteen years. Marro's statistical table, quoted in the same

connection, shows the age of fourteen to be that at which Italian teachers note the greatest number of faults in children. Sheldon (52) found predatory societies most numerous among boys between ten and fifteen years. Mrs. Schoff (49) found that more than half of the ten thousand cases brought into court in Philadelphia in eight years were

between thirteen and sixteen years of age. The report, for 1915, of the Juvenile Court of Los Angeles County, California, one of the largest in the entire country, shows a steady increase in the number of boy delinquents up to seventeen years, with a sudden and very marked decline thereafter to twenty-one, where the jurisdiction of the court ceases. Many more statistics could be quoted to show the youthfulness of offenders and the early age of first offenses, but those cited are typical.

When to the fact of youthfulness of offenders is added the now generally recognized fact that physiological and mental maturity, much more than real age, determine the capacity for moral accountability, the problems of delinquency and crime become clearly those of promoting the moral evolution of childhood and adolescence. At best the problem is difficult enough. With complications incident to structural and functional retardation or arrest of development either physical or mental, the difficulties are disproportionately increased. There seem to be few cases in which the problem of crime is not a problem of childhood and youth. To know the criminal one must know him as a child. If crime and delinquency are ever to be materially decreased the remedy is surely to be sought along the line of better methods for the formation of character in early life, rather than in the reformation of delinquents and criminals, important as the latter service is. We must learn that formation is better than reformation; that prevention is better than cure; that the problem of crime is in the main an educational one.

Nature of juvenile offenses. The nature of offenses varies in a rather definite and uniform way with age and sex, and to a minor degree with season, climate, race, stage of civilization, and many other factors. Age affects the nature of offenses because in earlier years the physical

strength and mental capacity necessary for certain offenses are lacking; because the nature of the life of children and adults subjects each to different temptations, but perhaps chiefly because the impulses and instincts which are a prime factor in causation differ radically with age. Sex differences are apparently due in part to deep-seated physical and mental disparities between the sexes, but also in part to social factors. Individual temperaments, traits, and capacities, whatever their cause, often show themselves in such characteristic fashion as almost to serve the purpose of identification of the offender. Truancy, vagrancy, and sexual offenses are most frequent in the Spring. With some of the other factors the relationship is more obscure, but the essential fact remains — all have more or less effect upon the nature of delinquencies.

The typical offense of boys is some form of theft. Ferriani observes that “the child making his first criminal steps begins ninety times out of a hundred with theft”; and so natural does this writer regard this offense that he adds that, “from eight to fourteen years the child is almost always a thief” (10, p. 372). The most prevalent offense of girls is incorrigibility, usually involving immorality. According to Breckenridge and Abbott (7, p. 314), eighty per cent of the 2440 girls appearing before the Chicago Juvenile Court, in the first ten years of its work, were brought in for immorality. Hall (25, vol. 1, p. 333) constructs a table from the Census of 1890, showing the distribution of all offenses for those of both sexes who were committed to juvenile reformatories between the ages of seven and twenty-one years. The order of greatest frequency is incorrigibility, petit larceny, vagrancy, larceny, burglary, truancy, disorderly conduct, assaults, etc. Truancy culminates at thirteen; incorrigibility and malicious mischief at fourteen; petit larceny, vagrancy, disorderly

conduct, and assaults at fifteen; larceny and burglary at sixteen years. Crimes against persons reach their culmination several years later than those against property.

Peculiar or special circumstances or local conditions also affect the nature of delinquency to some extent. To cite a single example, the records show that during the year 1915 the great majority of seventeen-year-old boys brought into the Juvenile Court of Los Angeles County, California, were charged with "speeding and violations of traffic laws." Not only is this offense the most common one by far for this age, but it is so common as to make seventeen the age of the greatest number of offenses for the year.

The typical delinquent. Gathering together all we know about juvenile delinquents, let us form a composite word picture of the type. As he appears in our juvenile courts the country over, the typical delinquent is a boy (eight or nine times out of ten); he is approximately fifteen years old; is slightly under the normal height and weight for his age; may have one or more physical defects of a fairly serious sort, but is probably not more seriously defective than the average public school child (nine times out of ten); his schooling has been more or less interfered with by various causes; his intelligence is normal (three times out of four), although he may be a dull-normal or border-land case; he has been and probably still is engaged in some one of the street trades or other occupation for gain; he does not care much for school, and will quit as soon as the law allows, if he has not already done so; he is a member of a gang; is native-born of native-born parents; his home ranks somewhere between the very poor and that of the comfortable working class; the chances are even that one parent is dead, has deserted, or that the parents have separated, and that one parent is addicted to drink; if there are several other children in the family, he has one brother or sis-

ter who is delinquent; the charge against him includes some sort of theft, and he has been guilty of more than one offense; his condition is due one fourth to family inheritance, and three fourths to environmental causes of which the influence of his gang is an important element; if he is to be reclaimed, he will either have to be removed from his present surroundings, or a radical change will have to be made in them, and he be held to the course of rectitude by some strong hand until correct habits and ideals are well established; of such reclamation in his case there are nine chances in ten of success. It hardly needs be said that this picture is not to be taken too literally, but every statement in it has statistical backing, and it is not far from true of the *average* delinquent who appears in court. There are extremes at both ends of the curve of distribution whose portrait would, of course, be quite different, but the vast number of the type described present a challenge to parents, teachers, and social reformers.

Remedies for delinquency. Without in the least minimizing the difficulty of the task, the facts of moral development clearly suggest many feasible means of preventing delinquency. The major problem is one of moral training and education. The only hope of stemming the increasing tide of youthful delinquency lies in a better understanding of the contributory causes, and a prompt and continued attack at the roots of the evil. The rapid extension of our knowledge of child nature and the factors which enter into character formation, and the widest possible dissemination of such knowledge as we have, is therefore the first important step. Social and economic conditions in general must be improved as much and as fast as possible. There must be education for parenthood and home making, and the means with which to make and maintain proper homes must be more easily available than now. Cities,

towns, and villages must be built with some consideration of the fact that they are to be the dwelling-place of children, as well as places for the conduct of business and industry and the carrying-on of a life suitable to adults. Facilities for healthful and proper play and recreation, and for the legitimate exercise of all desirable youthful instincts, must be everywhere a prime consideration. Not merely must there be places for play, but there must be organization and direction of play to further moral ends. Organizations for the cultivation and safeguarding of the normal and legitimate social instincts — public playgrounds, boys' clubs, girls' clubs, Boy Scouts, Camp-Fire Girls, athletic teams, and the like — are present-day movements with large possibilities for moral training. There is vast room for improvement and perfecting of the methods and means of moral training in homes, churches, and schools. Public libraries, museums, the theater, the motion picture, night and continuation schools, and the like, have vast unused opportunities to further the making of a superior citizenry.

When all these agencies have done their work, there will still remain task enough for the modernized and improved juvenile courts, parental schools, industrial and reformatory institutions, homes for epileptics and feeble-minded, with their trained judges, probation officers, psychologists, vocational teachers, and vocational guides to take care of those who will still fail to respond to the formative influences already mentioned. Constructive and preventive work is the ideal, but corrective work will always have a place. A long step in advance will have been taken when we learn to recognize early and to segregate the feeble-minded, epileptic, and otherwise exceptional children for special treatment suited to their condition.

Looking to the future, eugenics must be called to our aid in the elimination of unfit parentage. By education and

by legislation we must see that fewer physically and mentally defective, diseased, and otherwise handicapped children are born, for many of these classes are almost certain to end as criminals, in spite of the best of care and training. Positively we must see that all children are better born. None of the suggestions we here present are utopian or visionary. We have suggested no movement, organization, agency, method, or ideal that has not already been used effectively somewhere by somebody. For the furtherance of many of the ideals involved in these suggestions a large measure of the responsibility rests with the school. Most of them will be realized largely by education of the social conscience, which is already more alive to the best interests of childhood than ever before in the history of this or any country.

SUMMARY

1. Our conceptions of juvenile delinquency have undergone entire reconstruction since the beginning of the twentieth century.
2. The causation of juvenile delinquency is very complex; there is no one cause.
3. One should be very careful neither to over-emphasize the effect of heredity on the one hand, nor that of environment on the other.
4. Neglect, orphanage, education in crime, confinement with criminals, suggestion, ignorance, perverted instincts, etc., cause much delinquency which is clearly preventable.
5. Improper, inefficient, ill-timed methods of moral education and training, especially the divorcing of moral from intellectual training, are responsible for most of the moral turpitude of a less serious sort than that

- which brings children into juvenile courts and reformatory and penal institutions.
6. The large percentage of successful reformations (eighty per cent or more in many well-conducted reformatories) indicates the extent to which improved methods of training and education may meet the problem.
 7. Remediable social and economic injustices and inequalities, poverty, bad housing, unemployment, lack of vocational training, etc., are larger factors than are commonly admitted.
 8. The conclusion that delinquency is about one third a eugenic and two thirds a euthenic problem seems warranted by the facts.
 9. In a broad way it may be truthfully stated that society has now the information and the means at its disposal to eliminate, in a generation or two, at least three fourths of the delinquency it now permits.
 10. The *laissez-faire* attitude of society will be chiefly to blame if delinquency is not so reduced in the near future.

QUESTIONS AND TOPICS

1. Why has our conception of juvenile faults, immoralities, and crimes undergone such a radical transformation in recent years?
2. Are you convinced that there is no one all-important cause of juvenile delinquency? Why or why not?
3. Explain and illustrate the relation of instincts to delinquency.
4. Explain why feeble-mindedness predisposes to delinquency.
5. Explain why the nature of offenses against law and morality vary with age and sex.
6. Gather all the facts possible about some delinquent child in your community. Try to diagnose the case, prescribe a remedy, and predict the outcome. Healy's (31) type cases will be suggestive.
7. Study carefully the home, industrial, educational, social, and recreational conditions of your community, and explain why your community has less (or more) delinquency than the average.

8. Observe as closely as possible the activities of some boys' gang in your community, and list its good and bad effects in so far as you can determine them.
9. Would you break up all boys' gangs or not? Why?
10. What constructive measures does the known relation of feeble-mindedness to delinquency suggest?
11. State specifically and in some detail the part the school must take in the prevention of delinquency.
12. What are the essential qualifications of a juvenile judge? Of a probation officer? Of a juvenile police officer?

SELECTED BIBLIOGRAPHY

- *1. Addams, Jane. *The Spirit of Youth and the City Streets*. (1909.) 162 pp.
- *2. Addams, Jane. *A New Conscience and an Ancient Evil*. (1912.) 219 pp.
3. Adler, F. *Moral Instruction of Children*. (1892.) 278 pp. Especially chap. v and Appendix.
4. Barnett, Mary G. *Young Delinquents: A Study of Reformatory and Industrial Schools* (In Great Britain). (1913.) 222 pp.
5. Bohannon, E. W. "A Study of Peculiar and Exceptional Children"; in *Ped. Sem.*, vol. 4, pp. 3-60.
6. Bonger, W. A. *Criminality and Economic Conditions*. (1916.) 706 pp.
- *7. Breckenridge, S. P., and Abbott, E. *The Delinquent Child and the Home*. (1912.) 360 pp.
8. Burk, F. "Teasing and Bullying"; in *Ped. Sem.*, vol. 4, pp. 336-71.
9. Burk, Mrs. C. F. "The Collecting Instinct"; in *Ped. Sem.*, 1900, vol. 7, pp. 179-207. (See also Hall, *Aspects of Child Life and Education*, pp. 205-39.)
- *10. Chamberlain, A. F. *The Child* (1914), pp. 355-95.
11. Clopper, E. N. *Child Labor in the City Streets*. (1913.) 280 pp.
12. Coulter, E. K. *Children in the Shadow*. (1913.) 277 pp.
13. Conn, H. W. *Social Heredity and Social Evolution* (1914), pp. 72-125.
14. Crafts, L. W. "Bibliography of Feeble-mindedness in Relation to Juvenile Delinquency"; in *Jour. of Delinquency*, vol. 1, pp. 195-208.
15. Darrah, Miss E. M. "Children's Attitude Toward Law"; in Barnes's *Studies in Education*, vol. 1, pp. 213-16, and 254-58.
16. Davenport, C. B. "Nomadism, or the Wandering Impulse, with Special Reference to Heredity"; in *The Feebly Inhibited*, pt. 1, pp. 1-26 (1915.) 158 pp.
17. Dawson, G. "Psychic Rudiments and Morality"; in *Am. Jour. of Psy.*, vol. 11, pp. 181-224.
18. Dewey, John. *Moral Principles in Education*. (1909.) 61 pp.
19. Drummond, W. B. *An Introduction to Child Study* (1908), pp. 281-97.

20. Fernald, Grace M. "Report of the Psychological Work at the California School for Girls"; in *Jour. of Delinquency*, vol. 1, pp. 22-32.
21. Goddard, H. H. *Feeble-mindedness: Its Causes and Consequences*. (1914.) 599 pp.
- *22. Goddard, H. H. *The Criminal Imbecile*. (1915.) 157 pp.
- *23. Goldmark, Pauline, and True, Ruth S. *Boyhood and Lawlessness*, and *The Neglected Girl*. (1914.) 204 pp. and 148 pp.
24. Guncel, J. E. *Boyville*. (1905.) 219 pp.
25. Hall, G. S. *Adolescence*. (1904.) 2 vols. 589 pp. and 784 pp.
26. Hall, G. S. *Youth: Its Education, Regimen, and Hygiene*. Chaps. VII, IX, and XII. (1904.) 379 pp.
27. Hall, G. S. "Children's Lies"; in *Ped. Sem.*, vol. 1, pp. 211-18. (See also his *Educational Problems* (1911), vol. 1, chap. VI, pp. 345-87.)
- *28. Hall, G. S. *Educational Problems* (1911), vol. 1, chap. V, pp. 200-344.
29. Hall, G. S., and Smith, T. L. "Curiosity and Interest"; in *Ped. Sem.*, 1903, vol. 10, pp. 315-58. (See also *Aspects of Child Life and Education*, pp. 84-141.)
30. Hart, H. H. *The Preventive Treatment of Neglected Children*. (1910.) 430 pp.
- *31. Healy, W. *The Individual Delinquent*. (1915.) 830 pp. (Exhaustive bibliography.)
32. Healy, W. *Pathological Lying, Accusation and Swindling*. (1915.) 286 pp.
33. Johnson, J. "Rudimentary Society among Boys"; in *Johns Hopkins Univ. Studies in Hist. and Pol. Sci.*, vol. 2, pp. 495-546.
34. Jung, C. G. "The Association Method"; in *Lectures and Add. on Psy. and Ped.*, Twentieth Anniversary of Clark Univ., pp. 38-89.
35. King, I. *The Psychology of Child Development* (1903), chap. XI, pp. 132-52.
36. Kline, L. W. "Truancy as Related to the Migratory Instinct"; in *Ped. Sem.*, vol. 5, pp. 381-420.
37. Kline, L. W., and France, C. J. "The Psychology of Ownership"; in *Ped. Sem.* (1899), vol. 6, pp. 421-70. (Also in *Aspects of Child Life and Education*, pp. 241-86.)
38. Kneeland, G. J. *Commercialized Prostitution in New York City*. (1913.) 334 pp.
39. Kohs, S. C. "Economic Conditions and Juvenile Delinquency"; in *Jour. of Delinquency*, vol. 1, pp. 118-24.
40. Le Bon, G. *The Crowd* (2d ed., 1897), pp. 15-44.
41. Mangold, G. B. *Problems of Child Welfare* (1914), pt. V, pp. 345-418. (Bibliography, pp. 506-08.)
42. Merrill, L. *Winning the Boy*. (1908.) Especially pp. 120-260.
43. Monroe, W. S. "The Money Sense of Children"; in *Ped. Sem.*, vol. 6, pp. 152-58.
44. Morrison, W. D. *Juvenile Offenders*. (1900.) 317 pp.

- 44a. Ordahl, Louise E.; and George. "A Study of 49 Female Convicts"; in *Jour. of Delinquency*, vol. 2, pp. 331-51.
45. Partridge, G. E. *Genetic Philosophy of Education* (1913), chaps. xi and xii, pp. 167-91. (G. Stanley Hall's views on moral and religious education.)
46. Partridge, G. E. "Studies in the Psychology of Alcohol"; in *Am. Jour. Psy.*, vol. 11, pp. 318-76.
- *47. Puffer, J. A. *The Boy and his Gang*. (1912.) 188 pp.
48. Riis, Jacob. *How the Other Half Lives*. (1890.) 304 pp. (Other books also.)
49. Schoff, Mrs. H. K. *The Wayward Child*. (1915.) 274 pp.
50. Sears, C. H. "Home and School Punishments"; in *Ped. Sem.*, vol. 6, pp. 159-87.
51. Schallenberger, Miss M. "Children's Rights as Seen by Themselves"; in *Ped. Sem.*, vol. 3, pp. 87-96.
52. Sheldon, H. D. "Institutional Activities of American Children"; in *Am. Jour. of Psy.*, vol. 9, pp. 425-48.
53. Sisson, Miss G. "Who has the Best Right?"; in Barnes's *Studies in Education*, vol. 1, pp. 259-63.
54. Smith, Miss T. L. "Obstinacy and Obedience"; in *Ped. Sem.*, vol. 12, pp. 27-54.
55. Street, I. R. Studies in Moral Education; in *Ped. Sem.*, vol. 4, pp. 5-40.
56. Sully, J. *Studies in Childhood* (1895), pp. 126-32 and 228-97.
57. Swift, E. J. *Mind in the Making* (1898), pp. 33-95.
58. Swift, E. J. *Youth and the Race*. (1912.) 342 pp.
59. Tanner, Miss A. *The Child* (1915), chaps. x and xi, pp. 261-312. (Bibliography.)
60. Terman, L. M., and Williams, J. H. "Preliminary Report of the Psychological Survey of Whittier State School"; in *Biennial Report* (1914), pp. 5-47.
61. Terman, L. M. *The Measurement of Intelligence*. (1916.) 362 pp.
62. Thorndike, E. L. *Notes on Child Study* (1901), chap. xvi, pp. 119-27.
63. Tracy, F. *The Psychology of Childhood* (1909), pp. 179-92.
64. Travis, T. *The Young Malefactor*. (1908.) 243 pp.
65. Triplett, N. "A Study of the Faults of Children"; in *Ped. Sem.*, vol. 10, pp. 200-38.
66. Williams, J. H. "Hereditary Nomadism and Delinquency"; in *Jour. of Delinquency*, vol. 1, pp. 209-30.
67. Westermarck, E. *The Origin and Development of Moral Ideas* (1906). Vol. 1, 716 pp.
68. Woods, F. A. *Mental and Moral Heredity in Royalty*. (1906.) 312 pp.

CHAPTER XI

GENERAL MENTAL DEVELOPMENT

I. GENERAL FACTS AND PRINCIPLES

The problems. A complete genetic account of child mind and consciousness is as yet far from possible. We must content ourselves, here, with the briefest sort of outline of the most important facts and theories bearing on a few of the significant phases of the subject. When we begin to consider what we should like to know about the general development of mind, a good many questions come at once to mind. What is the nature of mind? When does consciousness begin? What kind of consciousness is it in its early stages? What are the major changes that take place in it with age? How does mental development proceed? By what means is mental development hastened or hindered? In how far is the nature and course of development predetermined by innate, and in how far by external or environmental, factors. What laws govern the growth of mind? How does the nature and content of child mind differ from that of the adult? How and why do the minds of individual children differ among themselves?

We have already given partial answers to some of these questions in the course of our discussion of certain aspects of child behavior. The reader has already been made familiar with the method by which such problems are being attacked. We need hardly say that the nature of some of them is such that no complete answer is possible at present. Experimental solution of some of them is extremely difficult, if not impossible, and for the solution of still others much more time and effort is yet required. A glance

through the literature of this phase of our subject will readily convince any one of the fragmentary nature of our knowledge and the danger incident to attempts to generalize. These difficulties doubtless account for the very limited number of chapters to be found in the literature on the topic as we attempt to treat it here.

The nature of mind. The new physiological psychology of the generation just passing has sought to find for every mental state or process a correlative change in the neuro-physical mechanism. Its belief in such correlation has been crystallized into the expression, *no psychosis without neurosis*. This expression states the psychologist's belief in the most intimate relation between mind and body. The thoroughgoing geneticist goes a step farther. Applying Darwin's great idea, it becomes a fundamental principle of genetic psychology that the mind, like the body, is a biological product which has developed with the body in the race, and therefore develops with the body in the individual.¹ Such a view implies not only continuous change, but makes mind vastly larger and more complex than consciousness, which, at best, is only an infinitesimal fraction of mind temporarily passing in review, as it were, before the subject. Mind in its broader aspect is constituted of the sum total of all mental processes, past and present. Not only so, but for a true understanding of any individual mind we need a complete natural history of the physical and mental development of the race as well as of the individual. It is, perhaps, needless to say that such a conception presents an aim, a method of attack, and a point of view, rather than an attainable ideal. Its fruitfulness must be the measure of its true worth.

¹ On the topics discussed in this and the next sections the student should read the brief résumé of the views of G. Stanley Hall to be found in Partridge (32, pp. 14-87), or for fuller discussion the references listed in his bibliographies (pp. 31, 58, and 71).

We have reason to expect that if mind is the product of countless ages of continuous development, much of its deeper content must lie below the threshold of consciousness and can, therefore, not be satisfactorily studied or understood by the method of introspection any more than the evolution of the physical body can be completely made out by the dissection of its adult form. The problem presents further difficulty by reason of the fact that the human mind, especially that of the child, is never static, fixed, complete, or entirely intelligible to itself. It is never twice the same in any two persons, nor ever exactly the same for any individual at different times. Again, it is never what it is at any time solely as a result of individual experience, but carries in its every aspect the marks of its racial origin. The peculiar difficulty of understanding mind fully lies chiefly in the fact that its most fundamental and significant traits, its highest capacities, its strongest impulses are fundamentally conditioned by the emotions, and the instincts, which are exceedingly elusive and recalcitrant to introspection and are not analyzed by consciousness.

Origin of mind. Let us admit at the beginning that the problem of the origin of mind in either the race or the individual is a purely hypothetical one, which can probably never be scientifically solved with entire satisfaction. The problem is one of greater philosophical than it is of practical concern. We shall not stop to argue the question nor discuss in detail the probability of mind being coexistent or synonymous with life itself, or whether it is something added at some particular stage of development. Our study of non-learned behavior should have made it clear that chemo-physical responses (tropisms) seem to have long preceded sentiency, awareness, and certainly sense-perception or cognition in the human sense, as we know them. There is general agreement among biologists and psycholo-

gists that the simplest conscious processes are probably found in the animal series when a nervous system is present. There is equally general agreement that in the lowest forms the higher mental processes characteristic of the human mind are certainly absent. There is a vast amount of evidence from both phylogeny and ontogeny to indicate an ascending series of developments from mere sentiency to the highest reasoning of the human intellect. There is little reason to doubt that all minds have had a similar origin, a common function and, so far as each has gone, a somewhat analogous development.

The statement that "all consciousness is motor" has become an axiom in psychology. There is implied in this statement the conception that mind and consciousness have their origin in or in relation to the movements made by an organism in response to its environment. Stated axiomatically, in slightly different form, it might be said that where there has been no movement there is no mind. The most careful study of mind in all its various stages and degrees of complexity reveals no distinct and separate or self-sufficient entity. Mind is one aspect of a unitary life process. It has its place, its function, its part to play in relation to and not apart from the body. In its simplest form, that part seems clearly to be some sort of mediation of the universal process of reception of stimuli, their recognition and motor responses to them. The only essential differences between the simplest and the most highly complex mental processes are differences of degree. As the whole complex neural structure is built upon the same general plan as the neurone — a mechanism for receiving and responding to stimuli — so the whole mental structure is constituted of a parallel series of processes, differing in complexity with the nature of the response which it mediates or accompanies.

It has been one of the greatest contributions of genetic psychology that it has proven the exceedingly intricate relation between motor and mental activity and development. In the lower forms of consciousness this relationship is more immediate, definite, and most easily understood, but there is no discoverable break anywhere by means of which we can distinguish in function the consciousness involved in immediate motor response to a simple sensory stimulus from that involved in a highly complex series of reasoning processes. It seems to be the very essence of mental function that it bear direct relationship to the world of influences external to itself, tending to respond to that which acts upon it by cognitive (knowing), affective (feeling), and conative (striving) processes. Mind had its origin in movement; its function is still and always the modification or direction of responses; its development can take place only in definite, vital, dynamic situations in which its natural function has free play.

It is much beyond our present purpose to discuss in detail the steps in the elaboration of mental functions throughout the ascending scale of animal life, or even in the human family. While it is unsafe to follow closely an analogy based upon physical evolution, since mind is something entirely different in its nature, still such an analogy is useful in indicating the lines upon which such a discussion would proceed. We can only say that the striking changes in physical evolution are no more interesting and illuminating than those in mental evolution. We must content ourselves with an attempt to give some rough idea of the main tendencies of development of the mind of the individual human being.

When does consciousness begin? The interest in this question has been from the first chiefly a philosophical one. **Practically it is very much more important to know what**

kind of consciousness the infant has, when it has begun, how it develops, and how its development may be directed. Much of the early study of infant consciousness, however, aimed at an answer to this question, and a brief résumé of conclusions has at least theoretical value. There is not time to enter into detailed discussion of the ancient dispute over the question of innate ideas. We can only state, somewhat dogmatically, at the same time disclaiming any desire to be dogmatic, that we do not here accept the extreme *tabula rasa* conception of mind. We have already indicated our conviction that consciousness, and especially mind in its broader sense, is conditioned by the selected physical and mental qualities of the race. This, however, does not bind us to a belief in the presence of *ideas* prior to sensory experience. Philosophy, observation, and experiment alike unite in indicating that mind is partly predetermined and partly determined by individual experience. It is inconceivable, say the geneticists, that the endless process of time through which body and mind have evolved together in the race should not have selected and indelibly stamped upon each the effects of their innumerable, intricate relationships and interdependencies. All the fundamental instinctive motor tendencies of man have definite correlates in affective and cognitive processes. One is born with the general pattern of his mental life already definitely laid out. One is born with well-defined capacities to experience sensations, to form ideas, to have images, to retain them in memory, to associate, to attend, to judge, to analyze and synthesize ideas, and to have affective experiences all of a distinctively human type. No normal human being is ever predisposed to live the mental life of a dog or of an ape. All of his capacities are to a degree predetermined in form and content by the selected mental activity of all his forbears from whom he inherits a neural mechanism

whose qualities and functional capacities their lives have chiefly determined. And yet all the evidence goes to show that prior to sensory experience there are no ideas, images, conscious memories, concepts, judgments or reasoning processes. All these and other conscious states are acquired by the individual through his own activity, but the capacity to acquire them is a distinctive feature of his human heritage.

The view we have just presented finds ample justification in the numerous careful studies of the psychology of infancy, of which those of Preyer (34), Miss Shinn (41), Major (26), and Dearborn (10) are typical. These and many other studies leave little doubt that the child at some stage of embryonic life is totally devoid of sensory experience and certainly, therefore, of all higher mental processes. Embryological anatomy, also, comes to the aid of psychology by its determination of a time prior to which the nervous system is functionally too immature to transmit nervous impulses.

When all is said, the time at which consciousness begins is, and will remain, purely conjectural. The experience of sensation must be judged by the methods of the naturalist and the biologist, that is, by inference and analogy, based upon the study of behavior, supplemented by the observations of the neurologist. So far as the latter are concerned, there seems little reason to question that all the sense organs are functionally mature for a considerable period before birth. Children prematurely born as much as two or more months have been seen to respond to sensory stimuli almost as readily as those born at the normal period. This has been taken to indicate that, in so far as the appropriate stimuli can affect the sense organs *in utero*, sensory experience is possible long before birth. Some vague, indefinite sort of prenatal consciousness is, there-

fore, postulated by many students of infancy, although its nature and content is difficult for us to conceive. The evidence on this point has been so fully presented in the references mentioned above, and so well summarized by Tracy (48) and Miss Tanner (43), that there is no need to present it here. It is sufficient for our purpose to say that the infant is born with a fully developed sensory equipment and perhaps a beginning of vague, undifferentiated consciousness. From this consciousness some would exclude impressions of sight, hearing, taste, and smell because of the improbability of stimulation of these senses prior to birth, but there is not total agreement upon this point. One word of caution, not always in the mind of observers, should be stated in this connection. It must not be forgotten that what the observers see is reactions to stimuli, from which they infer a conscious, mental process. Our study of reflexes and instinctive movements has surely shown us that the analogy from motor reaction to conscious process is by no means a safe one. All statements regarding the consciousness of the newborn must be accepted with an element of mental reservation. The less actual consciousness we attribute the nearer we shall be to the truth, without doubt.

Biologically considered, there seems to be something of a hierarchy of the senses. The sense of touch appears to be genetically the oldest, the "mother sense," of which all the others are differentiated forms. Being oldest racially and individually, and because its stimulation is entirely possible even in the embryonic period, it has been assumed to function first. It and the closely related senses of temperature, pain, strain, and movement have been assumed to furnish the content of the embryonic consciousness, if there be such. Very soon after birth, if not before, all the other senses begin to receive impressions and to add

their contribution to consciousness. From these, and the inherited predispositions mentioned above, that marvelous instrument which we know as the human mind takes its start.

The nature of consciousness in the newborn. The question "What is the baby thinking?" is one of perennial interest. This, too, it must be said, is a hypothetical question. It may, however, add something to our appreciation of the nature of infant mind if we quote a few rather interesting attempts at description of the probable qualitative nature of animal and infant consciousness. One of the earliest attempts was that oft-quoted one of Professor James (21, vol. 1, p. 488), that "the baby, assailed by eyes, ears, nose, skin, and entrails all at once, feels it all as one great, blooming, buzzing confusion." By this description he seems to wish to convey to us the idea of a total lack of relationship, organization, association, or meaning in early experience. His idea seems to be that of a unitary confusion, out of which, by a process of many repetitions, particular sensory experiences and ideas are to be gradually differentiated.

Unquestionably Thorndike's description of animal consciousness might serve almost as well as a description of infant consciousness at this stage. Speaking of the former he says: —

It is most like what we feel when consciousness contains little thought about anything — when we feel sense impressions in their first intention, so to speak; when we feel our own body and the impulses we give it. Sometimes one gets this animal consciousness for a while in swimming, for example. One feels the water, the sky, the birds above, but with no thoughts about them, or memories of how they looked at other times, or æsthetic judgments about their beauty; one feels no ideas about what movements he will make, but feels himself make them, feels his body throughout. Self-consciousness dies away. Social consciousness dies away. The

meanings and values and connections of things die away. One feels sense impressions, has impulses, feels the movements he makes; that is all.

Thus, by a process of elimination of what he feels certain must be absent from the infant's consciousness or that of the animal, he attempts to picture its real content and qualitative character. Whatever we may think of his success, a conscientious attempt to follow his method will amply repay any one who attempts it by giving increased insight into our problem.

Among others, well qualified to attempt such description, is Miss Shinn who, after her prolonged study of her niece, writes as follows:—

She took in with a dull comfort the gentle light that fell on her eyes, seeing without any sort of attention or comprehension the moving blurs of darkness that varied it. She felt motions and changes; she felt the action of her own muscles, and . . . disagreeable shocks of sound now and then broke through the silence, or perhaps through an unnoticed jumble of faint noises. She felt touches on her body from time to time . . . and steady, slight sensations of touch from her clothes, from arms that held her, from cushions on which she lay, poured in on her.

From time to time sensations of hunger and thirst, and once or twice of pain, made themselves felt through all the others, and mounted till they became distressing; from time to time a feeling of heightened comfort flowed over her as hunger and thirst were satisfied; or release from clothes, and the effect of the bath and rubbing on her circulation, increased the net sense of well-being. . . . For the rest, she lay empty-minded, neither consciously comfortable nor uncomfortable, yet on the whole pervaded with a dull sense of well-being. Of the people about her, of her mother's face, of her own existence, of desire or fear, she knew nothing. Yet this dim dream was flecked all through with the beginnings of later comparison and choice (41, pp. 55 ff.).

Careful consideration of these three descriptions reveals quite a degree of difference of conception. Such a difference is still further indicated in our final quotation on this

subject from King (22, p. 32), who contends that, "if the child is conscious in these first days, it must be with a sort of consciousness of which we can form little idea — a mere feeling, or sentiency absolutely without definite reference of any kind. It is so hypothetical that it is of little use to speculate about it."

One of the insuperable difficulties in this whole matter is the fact that verbal description can never accurately convey an idea of mental contents or mental processes, so different from those which the introspector can himself experience. In the infant's first days one observes mind in its first intention, so to speak, relatively unaffected by other minds or personalities, untrammelled by tradition, unmodified by training, unassisted by speech, that very useful medium of abstract thought, and therefore indescribably different from our own.

Aside from conjecture as to the probable nature of the first consciousness, much of the content of the numerous baby biographies has to do with records of the first appearances of different perceptions, such as those of time, space, color, distance, movement; first recognition of objects; first memories; the first signs of fear, anger, jealousy; first voluntary acts, and the like. Much attention is also given to the order in which the various mental functions appear, and the order of their development. In this way the observers attempt to form an idea of the growth of infant consciousness.

In all fairness it must be said that we are not likely to have too many exact and painstaking accounts of the minutest detail of infant behavior. We may, perhaps, have too much assurance as to the accuracy of our interpretation of this behavior in terms of infant consciousness. There is much to justify the contention of King (22), that when it comes to the matter of determining the exact *time at*

which a given cognition, emotion, or volition is first present, or the *order* in which the mental functions appear, our effort is quite aside the mark. "The whole assumption," he says, "that these questions are of importance, and that something can be said about them, involves a radically wrong conception of the development of the child" (22, p. 17).

A truer conception of mind may be had by study of its processes as they relate to behavior than by analysis and description of mental states as such.¹ Our chief interest is to know how we may predict responses and how conscious states may be so modified as to effect desirable changes in behavior. All along we have been considering the child as a behaving organism. From the beginning of his life he has inborn tendencies to reactions, as we have learned, many of which are predetermined in form and in effectiveness by the nature of his neuro-muscular systems. But we have also learned that these predetermined responses are by no means adequate to all the needs of life. It is this inadequacy of inborn behavior which makes mental life such a useful asset. If there were no such inadequacy, mind would be a superfluity. But since inherited adjustments are inadequate to meet the higher needs, mental responses by doing so assume a place of exceptional significance.

The earliest consciousness must, then, be definitely related to and coördinate with the reception and recognition

¹ It should, perhaps, be said at this point that we are using the term *mind* as broader than either *consciousness* or *intelligence*, and inclusive of both, for it is, in fact, constituted of the phenomena of consciousness and intelligence. Consciousness may be thought of as awareness of the various phenomena of mental activity. Our conception of intelligence is now undergoing reconstruction, but for the present we may say that it is the capacity to make improved adaptations to environment by the intervention of mental processes.

of stimuli and the mediation of responses. Consciousness is for present-day psychologists a process definitely related to certain forms of behavior. When the only response called for is one of recognition of a stimulus or, perhaps, the recognition of its source, the process is simple; when it is for a very complicated response, the conscious processes are relatively complex. All the complexities of mental processes are accompaniments of the increasing complexity of impulses and are incident to and correlative with their integration, redirection, and control. Selective mental evolution is as natural and inevitable as the evolution of instincts. "Consciousness, then, exists whenever behavior is influenced by ideas or by feelings" (31, p. 319). Under whatever circumstances we examine it, we always find the whole mind at work at its function of control of physical, mental, or social adjustment. Its activity always bears some relation to behavior, and it is always unitary and connected. No other conception is consonant with the biological viewpoint which we have followed throughout our whole discussion. If viewed functionally, then, mind cannot be thought of as an independent entity, nor as a group of such entities or "faculties" more or less independent of each other.

The infant mind especially, like that of the animal, unquestionably deals with totalities and is itself an undifferentiated totality of processes very simple and elemental in nature. Our own developed minds not only are constituted of an integrated set of mental processes of much greater functional capacity, but they also have a content which the infant's mind lacks. It seems certain that sensations, perceptions, memory images, thoughts, affective and conative states, etc., as we experience them, can have no existence as separate phenomena. They are part of a unitary life process. There is every evidence that for some months the infant has no consciousness of self (20),

which for us helps both to unify and to differentiate conscious life.

Admitting the danger of drawing an analogy from our study of the evolutionary differentiation of such physical functions as respiration, circulation, digestion, etc., from a simpler unitary function, it does seem clear that the various components of consciousness just enumerated represent a similar division of mental functions in accord with a plan found everywhere in nature. How or how rapidly this differentiation takes place and when it becomes clearly conscious is exceedingly difficult to say. The means by which it is effected, however, is none other than the activity of the mind itself, as, true to the inner impulses which actuate it, it mediates responses with increasing effectiveness. The multiplication of such differentiations and the perfecting of the various functions can be effected in no other way. The fundamental laws of mental growth are, in this particular, no different from those of the physical.

If we are consistent in holding to our functional interpretation of mind, we cannot say that there is first a consciousness of simple sensations, then of a unification of sensations into perceptions, later the rise of images of memory, concepts, ideas, etc., and finally an organization of all into reasoning processes. Rather we shall have to say that all these processes and contents exist in germ in every modification of reaction from the beginning. The process we call organization is in reality a process of gradual differentiation from a vague unitary whole which is none of these processes, and yet is all of them. Consciousness is able later in life to examine one or other aspect of itself, but in any other activity than that of introspection all the mental functions are integral parts of a complex; they do not exist alone. Consciousness of them grows out of a recognition

of their meaning, and they unquestionably acquire meaning solely as they play their respective parts in mediating responses.

Obviously the development of some of the mental functions progresses more rapidly than others. Sense-perception matures earlier than conscious memory; it in turn than reasoning. The reason is that the latter are not only processes but they deal with contents, furnished by the senses, which require time to be built up. Sense-perception is immediate and simple; the higher mental processes are derived and complex. Long after all the functional capacities of the mind are in full operation, however, the relatively imperfect use made of them constitutes the chief justification for the study of child as distinct from adult psychology. A large part of the remainder of this and the following chapter will be devoted to a consideration of the development of the various mental capacities.

Periods of mental development. The division of mental development into stages bounded by definite years is very familiar to all who have read, to any extent, the literature of child study. We have not space nor is there need at this point to attempt detailed characterization of the various mental stages. We have in earlier chapters shown our recognition of the value of such a procedure by our characterization by periods of the play, speech, and drawing capacities. Of periodicity and rhythm in mental development there can be no doubt, for we meet striking evidences of it in many different respects.

It seems best, having said so much, to say now that we are gradually learning that what King calls "the illusion of definite periods" has been endangering our recognition of the more important fact that, in every individual, development is a continuous process of successive changes rather than a succession of distinct and widely different periods.

It is true that there are certain outstanding characteristics of infancy and of adolescence, for example, which make a differentiation of these from other periods not only possible but useful. It cannot be denied that there are points in mental development when, by a combination of factors, what appear to be very sudden and marked changes take place, just as we know they do in physical development. It is, however, the wide individual differences in this matter that we wish to emphasize.

We are merely stressing the point, sometimes neglected, that in our attempts to describe the average child — “that plenary being ‘the child,’” as Dewey expresses it (22, p. xvii) — we must not overlook the fact that in the individual case, at least from the second or third year on, there is no fundamental capacity or trait which, present then, is wholly lacking thereafter, and no later development which had not its beginning in the period preceding this age. Development through infancy, childhood, and youth to maturity is, as a rule, an orderly and lawful process. We must not allow extreme cases to obscure this fact. Any thoughtful attempt to characterize a particular period, if based upon the scientific facts in the case, must bring the conviction that each stage merges into the succeeding one, and that the obvious, outstanding traits of each period have their beginnings in preceding stages and merge into succeeding ones.

In general it may be said that the character of mental life at any period is determined by the necessities of the period. In early infancy, for example, lack of mental content coupled with the native impulse to activity results in a rapid accumulation of sensory and motor experience. The senses are ready for stimulation, the muscles for activity. Without such content as is furnished through these avenues the higher mental processes are impossible, and

it is not strange that this period strikes us as largely a period of sensory-motor acquisition. But even here motor habits are being formed and the basis for conscious memory laid down, associations established, affective states initiated, habits formed, and little by little inhibitions, volitions, and practical judgments foreshadowed, and the basis laid for the constructive reasoning processes of maturer years. Quite as much harm may, therefore, result from underestimating as from overestimating the ability of young children to use the capacities supposed to belong only to older heads.

Similarly if at adolescence a marked improvement of reasoning capacity seems to be a characteristic of the period, we must not allow this fact to obscure the equally important one that the mills of reasoning do not grind without grist. It is the richness, variety, and suitability of ideas, the stimulation and the checking of impulses by the experience of all the preceding years, which furnishes the content without which clear and logical thinking is impossible. The apparent sudden blossoming of such capacities often mystifies and surprises us, but it may be that when we know more of the causes which further mental development much of the mystery will disappear, and we shall find an orderliness and regularity in mental life that we now only faintly glimpse.

Some general principles. The ultimate practical values of child psychology depend to a great extent upon the possibility of discovering and formulating general principles of mental growth which can be accepted as guides to mental training. The science of child psychology is yet new, and most of its laws in the formative and, therefore, tentative stage. A few general principles, however, are becoming clear.

(1) *The principle of growth.* The basic principle since

the development and acceptance of the theory of evolution is the principle of growth. Our entire discussion has assumed, elaborated, and illustrated this principle. If mind is not an evolution, there is no excuse for a genetic or child psychology. If it is, the growth concept applied to all its phases gives the most illuminating and only correct concept of its nature and content. The plasticity, growth, and development of child mind are so obvious, and have been so often stressed throughout our earlier chapters, that the correctness and importance of this principle need no further emphasis.

(2) *The "law of recapitulation."* One of the earliest and most general of the principles formulated by child study is the so-called "law of recapitulation," the application of which in the physical field we have already considered. The proponents of this "law" hold that the mind is not only a growth marked by progressive changes in the individual and in the race, but that the individual mind in the course of its development passes through more or less definite stages or periods, corresponding to the successive stages through which mind has passed in the animal series from the lowest to the highest forms. It is particularly stated that the stages through which the human mind has passed are recapitulated, — lived over again in the *order* in which they were passed through in the evolution of the genus homo. The most ardent advocates of the theory admit that it is much more difficult to establish than the theory of physical recapitulation which, as we have seen, is not universally accepted among scientists. Stages overlap, some are missing, frequent reversals of order are noted, some stages occupy exceedingly short and others excessively long periods, all without adequate explanation. Much use is made of rather questionable analogies with physical development, but perhaps chief dependence is

placed in the study of psychic rudiments, atavisms, rever-
sions, objectless emotions, and the like. By far the greater
part of the evidence on mental recapitulation has been
gathered by President Hall and his students, and largely
upon it and our preceding principle he has founded a ge-
netic philosophy of education. His explanation of the breaks
in the parallelism between individual and racial develop-
ment is that other factors are at work tending to obscure
and cover up the real relationships. Among these the most
important are the traditions of adult society and the forces
of the very radically-changed physical, social, and mental
environment into which children are now born. These it is
held tend to "suppress, modify, and obliterate his inher-
itance, and obscure the recapitulatory steps" (32, p. 31).

At the time when this theory was in the period of its
greatest popularity its pedagogical corollary — the so-
called culture-epoch theory — also had great vogue. This
theory which attempted to base the content and method
of education upon the assumption that for each recapitu-
latory stage there is a mental pabulum alone suited to it
was carried to ridiculous extremes. Racial activities in
their primitive form were formulated for each stage — the
pastoral, hunting, fishing stages, etc. — to furnish suitable
activity for the child while in the corresponding stage. The
theory has long since fallen into disrepute but, perhaps,
has been partly responsible for the present fortunate rec-
ognition of the fact that instruction must be suited to in-
dividual capacity and need.

W (3) *Periodicity and rhythm.* If the theory of recapitula-
tion should ultimately be rejected except in its very broad
and general implications we still have the principle of
periodicity and rhythm illustrated again and again in al-
most every phase of mental growth. The facts of periodic-
ity and rhythm are so obvious and so numerous that,

taken together, they establish the principle whatever the cause may be.

(4) *Continuity.* The principle of continuity in mental development asserts orderliness, sequence, and cause and effect relationships without which it would be impossible to understand mental content, mental activity, or the behavior which they condition. One experience conditions another, thought follows thought, elemental mental processes are associated with one another in one continuous stream of consciousness, higher mental processes are conditioned by and built upon lower and more elemental ones, and consciousness of self persists from day to day and year to year. These are accepted facts, all illustrative of the continuity of mental life upon which we place absolute dependence in our dealings with ourselves and with others.

(5) *Self-activity.* The principle of self-activity is a corollary of that of growth. As with the body, growth and development are impossible without activity, so is mental growth and development impossible without mental activity. It is a matter, therefore, of the profoundest significance that native impulses to mental activity of the most persistent and varied kind are the most obvious and universal traits in all normal children. This principle means that no environmental influence, no stimuli of any sort, no amount of provision of suitable media of instruction or training, no impartation of information, not even the inheritance of native reaction tendencies, can have the slightest effect in promoting mental development except as these things are responded to by the individual to be educated. Adults may furnish the educational means and materials, but they cannot create the motive power, nor can they perform the educative activities for a child. What the individual himself does, not what others do for him, to him, or in his presence, develops, trains, and educates

him. If the principles of education are reduced to their lowest terms they will all be found to be involved in this one — the principle of self-activity. All our present-day insistence upon spontaneity, freedom, initiative, and originality is evidence of our discovery and recognition of the fundamental truth of this doctrine. When we have come to use it as fully and as skillfully in practice as we now do in theory, educational practice will have made great progress.

(6) *Individual variation.* Studies of child mind have not only revealed vast and numberless individual differences, but have determined their general nature, extent, and distribution with so much certainty that in respect to large numbers we may be said to have laws of individual variation for particular mental traits which enable us to predict, with a fair degree of accuracy, the approximate number who will possess a given trait, and the approximate qualitative differences in a group. On the other hand, the principle furnishes a wholesome check against the tendency to draw hasty conclusions concerning an individual from data based on the average in a group.

(7) *Laws of learning.* It is now possible to formulate both general and special laws of learning. Thorndike (45) formulates three general ones which he terms: (1) the law of *readiness*; (2) the law of *exercise*; and (3) the law of *effect*. The law of readiness is best illustrated by the inborn tendencies to respond to stimuli, quite apart from previous experience or training. This and the extreme plasticity of the response-tendencies of the human being make learning possible. The law of exercise generalizes the facts that use tends to form and fix habits, to strengthen interests and powers, and to perfect skills. Negatively it implies that by disuse native tendencies detrimental to learning are changed, weakened, or abolished. The law of effect merely

generalizes upon many well-known facts of mental life, such as the fact that things which have been repeatedly together in consciousness with satisfaction to the subject tend to recur together and to reinforce one another, that repeated association of displeasure with a given response tends to inhibit it, that absence of opportunity to make a given response tends to make it disappear, and many similar facts of common experience.

There is not space to discuss the many specific laws of apperception, of association, of attention, of memory, of habit, of reasoning, etc., all of which are corollaries of the general laws of learning. These are familiar to students of general psychology. They and their applications make up much of the content of present day educational psychology, which occupies middle ground between child psychology and educational practice.

SUMMARY

1. The mind of man and the minds of the higher animals differ vastly in *degree* of development, but not essentially in *kind*.
2. Biologically, mind originated to meet necessities of adjustment for which instinct and impulse were insufficient.
3. Mind had its racial origin in movements, or in the process of their inhibition and control.
4. In individual life, also, conscious processes mediate responses; they never exist without purpose.
5. With the higher, constructive thought-processes especially, the law of inertia or the "law of parsimony" rules; they are used only when they must be.
6. Mind is a unit made of many highly differentiated sets of processes, mediating different functions. Sensing,

perceiving, remembering, associating, attending, imagining, reasoning are not separate "faculties," but designate various more or less complex functions of the mind at work.

7. The content of consciousness comes through the senses and the intellectual working over of sense materials, but physical and mental inheritance in part determine what contents shall be assimilated and what forms consciousness shall assume.
8. Just when consciousness begins is an interesting problem, but one of very much less importance than that of the nature of consciousness and the laws of its development.
9. The consciousness of infancy is a vague, confused unitary complex, out of which the various mental functions develop in the process of its activity.
10. The periodicity of mental development must not be allowed to obscure its continuity.
11. The ultimate object of child psychology is to formulate the laws of mental development and of learning.

QUESTIONS AND TOPICS

1. Explain the expressions "no psychosis without neurosis" and "all consciousness is motor."
2. If these expressions are true, what conclusions do you draw from them concerning sensory and motor activities in childhood?
3. What values may there be in attempts to determine when mind began in the race, and when consciousness begins in the individual?
4. Explain the viewpoint of genetic psychology.
5. What is meant by innate ideas? What is the *tabula rasa* idea of mind?
6. How can mental life be pre-determined if there are no innate ideas?
7. Does the order of development of the senses suggest anything concerning their relative importance in mental development?
8. What is the chief contribution of the so-called baby biographies?
9. Attempt by introspection and elimination to imagine what the mental life of a Laura Bridgman or a Helen Keller must be like, without sensations of sight or hearing.

10. What pedagogical bearing has the fact that thinking takes place **only** under the spur of a real need of adjustment in behavior?
11. What is the difficulty in attempting to mark off definite stages of mental development?
12. Give one or two illustrations under each of the general principles of mental development.

BIBLIOGRAPHY

The Bibliography for this chapter is combined with that at the close of Chapter XII.

NOTE

In using Chapters XI and XII teachers and students are urged to make large use of the supplementary references listed in our Bibliography (pp. 300-02), especially the numbers marked with a star (*) and numbers 8, 15, 36, 45, and 50. If this is done, the topics here very briefly treated can be studied quite satisfactorily and the student left with a good working knowledge of the present status of child psychology.

CHAPTER XII

GENERAL MENTAL DEVELOPMENT

II. PARTICULAR CAPACITIES

IF, now, we bear in mind what has been said about the essential unity of mental functions, we may with profit briefly outline some of the general tendencies of development of a few of the more important ones.

Sense-perception and apperception. Sensation is the elemental function which, through the medium of the highly specialized organs of sense, begins the process of differentiation of consciousness of which we have spoken. The nature of our mental content depends on nothing quite so much as upon that which the senses bring. Their activity, then, and the way in which they perform it, is a matter of prime importance, particularly throughout the early stages of mental growth. Observations and experiments show that sensory keenness, as indicated by the intensity of stimulus necessary to produce a just noticeable sensation (*stimulus limen*), unquestionably improves somewhat during the early years. This appears to be due to a certain immaturity of the organs of sense, and to inability to control the "set" of the sense organ for the reception of stimuli. Capacity for discrimination, as marked by the ability to recognize very slight differences in stimuli (*difference limen*), seems, also, to show rather decided improvement for some years. Recent experiments, however, that have been more successful in isolating particular sense capacities so as to test their elemental form, indicate that changes in them are by no means so great or so long continued as once was thought.

Both the stimulus *limen* and the difference *limen* appear now to be largely matters of native endowment which change very little with age, sex, training, or even with intelligence. The unquestioned improvement of facility in the exercise and use of these fundamental capacities seems to be due far more to cognitive factors, control of attention, better understanding, greater interest and need, and to the strength of affective elements than to changes in the elemental sense capacities themselves. Seashore (40), for example, finds the elemental capacity for discrimination of tones and of brief intervals of time about as good when the child enters school as it ever is, and that at this age many children excel many adults. He believes that when we succeed in isolating other elemental capacities we shall find the same to be true of them. If this should prove to be the case the so-called "training of the senses" is in reality not an improvement of elemental capacities, but rather a training in report, statement, control, and use of what the senses all along have given.

The perceptive and apperceptive processes, on the other hand, are to a far greater extent conditioned by exercise and training. Sense impressions, entirely meaningless to begin with, acquire, when repeated in a great variety of slightly different situations, vastly improved definiteness, meaning, and significance through the infant's reactions to them. Explorations that have been made of the mental content of little children indicate quantitative differences between infancy and childhood, and between childhood and maturity, which are almost unbelievably great. The instinctive and imitative responses of children tend to blind us to the inadequacy, incompleteness, and actual incorrectness of much of their mental content. The most rapid and continuous change from infancy to maturity is unquestionably a change in the quantity and quality

of the so-called "apperceptive mass." There can be little doubt that by far the greatest relative changes in this regard occur during the pre-school period, and again at adolescence. There are indications of periods of slow and of rapid quantitative and qualitative change, the reasons for which it would be worth our while to know far better than we do now.

But these are not the only changes that apperception undergoes. There are characteristic changes, also, in the forms or categories under which apperception takes place. So clearly have these been made out, and so definitely do they tend to follow one another, that tests of the presence of those which belong to certain stages of development are now made one of the criteria for estimating the level of a child's intelligence. As examples, we may cite the categories under which children define words, or "report" on observation of pictures. Apperceptive categories continue to undergo qualitative change until maturity, the higher types being often almost entirely absent, even at maturity, with those of low intelligence.

Attention. We no longer have place in psychology for a "faculty" or power of attention. As Baldwin has well said, "attention is a function of the content" (2, p. 444) of mind. It may almost be added that it is also a function of instinct, for that complex set of processes which we call attention concerns itself with things and activities which give promise of satisfying instinctive cravings, or which fill out the aching voids in present mental content, which is, perhaps, saying the same thing. Each instinct as it rises and ripens becomes an urgent impulse to certain distinctive processes of attention; prompts the gathering and using, from the vast field of possible experiences, such as are suited to present needs. What appetite and digestion are to the consumption and assimilation of food, attention

is to the gathering and assimilation of mental contents. The processes of attention do not naturally turn toward, or hold to, mental contents which find no instinctive readiness or basis in related past experience. It is, then, very clear that the objects of attention will vary from year to year as instincts ripen and as experience broadens. It is one of the most obvious traits of infancy and childhood that the strongest, newest, most vivid stimuli attract attention. Attention, too, is then dominated by the concrete, the real, the purely sensory, by moving things, and by things to which the child may respond by movement.

The domination of the instincts throughout childhood amply explains the fact that attentive processes are the prey to every passing whim. Distractions, if they make instinctive appeal, carry attention here and there in rapidly shifting pulses, and ability to maintain prolonged attention, to adapt attention to constructive purposes, to extend its range, or to protect it against fatigue, in such cases, are among the most difficult attainments of developing mind and among the surest signs of the growth of content. Only the capacity for reasoning, it is believed, shows higher correlation with intelligence than the capacity for sustaining attention. So important is the type and quality of attention in acquisition, retention, and use of knowledge that there is little reason to dissent from the view of Montessori that "when you have solved the problem of controlling the attention of the child, you have solved the entire problem of education." (N.E.A. 1915.)

Between infancy and maturity there is no total change in type, or quality, or in the objects of attention. There are, however, very marked changes in the relative prominence in maturer years of active or prolonged attention, of attention to the most significant rather than the most striking or obvious elements in situations, of attention to

ideas and abstractions rather than to things. Attention, also, becomes more stable, less easily distracted, less susceptible to fatigue, and is accompanied by far fewer gross bodily movements. The individual differences in all these particulars are so great that it seems useless to attempt to say to what degree children of a particular period have progressed from the state of the infant, described above, to that we have just characterized. Adults do not wholly lack the types and qualities of attention that belong to the infant; infants wholly, and children to a large extent, lack the mental content to which some adults attain. There is no more important and challenging problem before the child psychologist than to determine how attention can be made to serve continuously through life the ends that are most worth while.

Association. The connecting links between perceptions, ideas, movements and the process by which such connections are made, are both spoken of as association. It is of the process that we here speak. The act of association is in part pre-determined by native tendencies, and in part by the exigencies of chance or directed experience. However they may have originated, associations play an exceedingly important rôle in all the higher mental processes, furnishing as they do the supply of materials with which the mind works. The richness and meaning of conscious life, the wealth of its imagery, its fidelity, its originality, the degree of its organization, and the possibility of development of its higher forms of activity and usefulness, depend to no small degree upon the number, quality, and variety of its associative connections, and the rapidity and accuracy with which they are formed in consciousness. The experimental literature on some of these points is decidedly limited, so far as children are concerned, and such as we have is not in total agreement. It seems fairly certain, though, that

in all the respects mentioned above, there is improvement with age and experience. There are very great individual differences, as with all the higher capacities. Improvement in the rate of association is, perhaps, most in dispute, Ziehen and Meumann having found steady improvement with age, while Rusk, in a somewhat more carefully executed test, found no direct relation to age. Improvement in rapidity of association is measured by decrease in reaction time; in quality by the increasing tendency to attend to the most significant rather than the most obvious or customary associations, and to those belonging to the higher categories; in variety by the capacity to multiply associations at will; in fidelity by the improvement in the capacity to memorize and to retain definite associations between ideas and experiences. The character of associations gives some clue to the individual's mental type. There are indications, too, of an increase with age in the number of verbal associations. Depending as it does upon the general quality and organization of the neural tissues, the basal capacity of any individual is likely to be more a matter of endowment than of training.

Memory. The experimental literature on the development of memory is now so extensive that a volume could be written on it alone. Out of all this study a few important, outstanding facts may be mentioned.

Capacity for retention, like that of sensory discrimination, seems, as Professor James long ago indicated, to be an inborn one dependent upon the hereditary quality of the brain tissues and therefore not susceptible to improvement by training. This does not mean that the ability to memorize cannot be vastly improved. Few capacities are susceptible to greater improvement. Improvement in memorizing must be distinguished from improvement of native retentiveness. Retention of the effects of experiences, so

that they modify subsequent behavior, seems to be at first an organic rather than a conscious matter. All studies of the memories of infancy and early childhood made in later years show an almost complete loss of specific memories of childhood and infancy. Most of the innumerable experiences of the early years are so often repeated, in slightly different form, that they tend for this and other reasons to leave certain organic changes and sink below the level of consciousness. Rarely can any adult recall more than an isolated memory or two extending back as far as the third or fourth year, and the great mass of experiences prior to school age and even for several years thereafter is, for most adults, long forgotten past recall. This does not mean that the experiences of these years have left no trace, nor that they do not have conscious value. Nothing could be further from the truth. All experimentation and observation on this point at present seems to indicate that these years are the most important, in many ways, of the whole life.

The fact of total disappearance of the earliest memories throws some interesting light upon the nature of memory in infancy which confirms the findings of first-hand studies of the period itself. Major (26) attributes the weakness of memory in infancy to: (1) the weakness of association and the lack of continuity of mind; (2) to the lack of accurate localization of experience in time and place; (3) to the dominance of peripheral over central excitation of recall, and the consequent confusion of percepts with memory images; (4) to the lack of "trains of imagery"; and (5) to the lack of voluntary recall.

Hall's (19) fascinating exploration of his own early memories shows, what is perhaps the universal tendency of the memories of infancy, an apparent "lapse to vague and evanescent emotions" with only a "glint of vague familiarity" coming to consciousness when scenes, that **must**

have been very familiar, were re-presented to sense after the lapse of many years. On the other hand, long-forgotten incidents and scenes of later childhood "glowed up vividly in memory" in the presence of old associations. In his case memory became sequent and coherent from puberty on. He is certain, however, that the exceedingly rich and varied experience of his infancy and early childhood forms the whole basis and groundwork of his psychic life, and that the latter would have been entirely different had his environment been radically different from what it was. His conclusion is that the memories of infancy and childhood become a tangled meshwork of impressions, so felted together that no one image can be made to stand out from all the rest.

A wealth of experimental study has proven that memory span for digits, letters, nonsense syllables, and for connected meaningful material increases, from the time the child possesses any capacity at all in this respect, well into adolescence, if not to complete maturity. This, as well as other changes in memory capacity with age, is undoubtedly due to the great dependence of recall and recognition as well as of memorizing upon attention and association, both of which, as we have already indicated, improve with age and experience.

Most experiments show that there are minor fluctuations in the curves of improvement of all memory functions, periods of acceleration and retardation, perhaps correlative with those of physical growth.

Among the various special memories those for objects, scenes, sounds, movements, and the like are earlier in development than those for ideas, abstract concepts, or words, and especially those for emotions, memory for which becomes greatly strengthened after pubescence. The relative frequency and fidelity of memories of these various

types differ widely at successive stages of development. In this the natural and rapidly fluctuating interests of successive periods, as well as the prevailing type of imagery, are large factors. The most striking difference in the special memories of children and adults is the prevailing concreteness of those of the former, and the far greater predominance of verbal content in case of the latter. There is little doubt that in early years the generic imagery is quantitatively very different from the conceptual or generalized images which are possible with adults.

The relative prominence of visual, auditory, motor, tactual, olfactory, gustatory, and other minor types of imagery is not easily determined. It is certain that visual, auditory, motor, and a combination of the three make up by far the largest proportion of all imagery. It is difficult to isolate and test, with any degree of certainty, capacities which are so purely subjective and for accounts of which we must depend entirely upon introspection. While there has been much experimentation, the course of development of any one type or the changes in their relative strength at different periods is still much in doubt. There seems to be no doubt that the visual type is by far the most prevalent at every age, though it tends to change from a concrete-visual to a mixed verbal-content after childhood has passed. There is evidence from the experiments of Smedley (51, pp. 177, 197) that the auditory memory is stronger than the visual in the early years, but that after nine years it improves less rapidly and after fourteen years improves very little, while visual memory shows a large amount of improvement to at least seventeen years. More significant practically and educationally are the decided individual differences in type which are an exceedingly important element in determining capacity for some kinds of learning and for some vocations.

Imagination. Early infancy seems largely to be given over with abandon to absorption in sense impressions. Evidence of any free play of imagery is lacking. When imaging begins, imagery with recognition (memory proper) considerably precedes imagery without such reference (imagination in the narrower sense), as it precedes productive and constructive imagination, if we may be allowed to judge by behavior. When the time does come, at three years or so, when the mind frees itself from the literalness of sense there is a period when often there is for a time quite as much abandon to the wildest flights of imagination as formerly there was to sense impressions. This is seen in doll play, in imaginary companionship, in the imaginative lie, in interest in fairy stories, in the wealth of fabrication and make-believe which constitute so large a part of many children's plays and games. Normally the increase of experience in dealing with reality, training, and education causes this type of imagination to wane with the passing of early childhood.

In later childhood and adolescence imagination takes on new forms and different content. Personal and vocational ambitions and ideals, exploits, adventures, inventions, day-dreaming, and romancing are among the most prevalent forms for these years. All these have been repeatedly investigated by Barnes (1) and many others so that the changes in them with age are well known. These studies have much suggestiveness for the parent and teacher, but we must take it for granted that the reader will familiarize himself with some of the original studies. The unrestrained, fanciful type of imagination tends naturally to decline throughout childhood, except as it shows itself in the adolescent phenomena of day-dreaming and romance, where it may be quite as unrestrained as in early childhood.

Tests of imagination are difficult to apply or to evaluate.

The much used inkblot test reveals wide individual differences in the number and kind of imagery which the same inkblot suggests, as well as the fact that younger children are more imaginative in such a test than older ones. When they have been longer in use, linguistic invention, word-building tests, the Ebbinghaus completion test, interpretation of fables, and numerous others, now used in the various intelligence scales, will throw further light on the development of imagination. It is too early as yet to draw many trustworthy conclusions.

The imaginative activity of children is on the whole far more reproductive, imitative, fluctuating, purposeless, and unsystematic than that of the adolescent or the adult. Practical and ethical difficulties often arise in the case of those who cannot learn to turn dreaming into doing; to distinguish make-believe from reality; or to hold the mind to the completion of worthy ends. On the other hand, to stifle or to kill imagination not only deprives the individual of one of the greatest sources of possible harmless pleasure, but also destroys one of the chief agents of individual improvement and of human progress. Surely no thoughtful person would deprive the girl of her inalienable right to live over in doll or house play, with all the fullness and richness that imagination can suggest, the multitudinous incidents of ideal domestic life and industry. Certainly no wise parent or teacher will attempt to curb or harness the inventive, heroic, ambitious, lawless, and adventurous spirit of the pubescent boy by violent or sudden disillusionment. Few tasks require more understanding or greater wisdom than that of disciplining the imagination without destroying it.

Evolution of the feelings and emotions. According to Titchener (47, p. 226), "there is an elementary affective process, a feeling-element, which in our own minds is co-

ordinate with sensation and distinguishable from it, but which is nevertheless akin to sensation and is derived from the same source, made (so to speak) out of the same kind of primitive mental material: this elementary process is termed *affection*." In other words we not only sense, we feel; we not only make movements, have perceptions, memories, etc., but very often almost the entire significance of these things for consciousness lies in the way in which they affect us. Hall even contends that the feelings and emotions make up nine tenths of life, are "vastly more important and fundamental," and "are not only far greater in volume than thought, but their power in determining conduct outweighs the reason many fold" (32, p. 32). Intellect is more largely the individual aspect of mind; the emotions are predominantly racial.

As yet we know very little about the conscious aspect of the child's emotional life. Even with adults the conscious content of the various emotions has relatively little variety, and is obscure and elusive to introspection. To study this phase of mental life in children from that standpoint is, therefore, next to impossible, and we are thrown back upon such insight as can be had from the study of the natural history of the various emotions, which after all is far more illuminating than analysis or description of introspections could be. Detailed natural histories of the emotions of fear, anger, pity, love, jealousy, and many others have from time to time been published in the *Pedagogical Seminary*. The suggestiveness of this method can only be appreciated by the reading of one or more of the originals.

On the basis of such studies Hall makes some most striking contrasts of the emotional life of children and adults. "They are abandoned to joy, grief, passion, fear, and rage. They are bashful, show off, weep, laugh, desire, are curi-

ous, eager, regret, and swell with passion, not knowing that these last two are especially outlawed by our guild. There is color in their souls, brilliant, livid, loud. Their hearts are yet young, fresh, and in the golden age." On the other hand, "Our sensibilities are refined but our perspective is narrow, our experiences serene and regular, we are protected, our very philosophy as well as our religion suppresses and looks with some contempt even upon enthusiasm in matters of cold reason. . . . Our sentiments are over-subtilized and sophisticated and reduced to puny reactions to music and appreciation of art that is nine parts criticism and one part appreciation. What we have felt is second-hand, bookish, shop-worn, and the heart is parched and bankrupt" (17, vol. 2, pp. 59-60).

From many sources we have evidence that the affective elements in infant consciousness are relatively more transient, unstable, more often objectless, and more easily produced or inhibited by suggestion, when within the range of his experience, than is the case with older children and adults. In all these matters age and experience bring continuous change.

If we turn to the outward and organic expression of the emotions, their development seems to be marked by a certain periodicity, a waxing and waning of their strength with rather marked high points at four or five years, and again just following pubescence, with a decline thereafter. From this it has been argued that the emotions of children are stronger than those of adults. This conclusion is doubtful, if by it is meant anything more than that the expression of child emotion is more unrestrained. The fickleness and variability of the emotions throughout childhood rather argue for a relative weakness and instability of the conscious affective experience.

There is most certainly a development of capacity for the

control of emotional expression. The emotional abandon of certain periods and for certain emotions can be closely correlated with the nascency of certain instincts, such as those of self-preservation, pugnacity, sex, and the like. With the development of general mental and motor control, the elimination or modification of certain instinctive response tendencies, or their reduction to modified habits, the emotional life runs a more even and stable course, perhaps too stable, as our quotation above indicates.

Correlative with the changes of which we have been speaking there takes place a refinement and complicating of affective processes which give rise to the so-called higher emotions, the moods and sentiments which, to begin with, the infant no more possesses than he does highly complex states of cognition or thought, or the physical traits of maturity. The grosser, more primitive emotions belong to a more elemental stage of existence; the higher, more complex, more refined, such as the religious, the moral, and æsthetic, contain much more of the intellectual element and therefore reach their full development relatively late.

No one has better analyzed the relationship of emotional life to conduct and social relations than McDougall (27). He thinks that the organization of the emotional life into sentiments is of the utmost importance. "The sentiment is a growth in the structure of mind that is not natively given in the inherited constitution" (27, p. 159). Children do not, prior to extended experience, have sentiments. They experience fear, anger, and perhaps disgust, in the presence of persons or objects which naturally excite such emotions, but do not cherish hate as an abiding sentiment when the exciting object is absent. That comes only when "an organized system of emotional tendencies centered about some object" (27, p. 122), or the idea of some object, has been formed. It is the sentiments as thus defined

which McDougall thinks bring order and continuity into the chaos of primitive emotional life. So much weight do the affective elements of consciousness have that only those whose judgments of value and right are rooted in the highest and best moral sentiments have stability of moral principles and moral character. If, then, nine tenths of life is emotion and one tenth intellect, what proportion of our time and effort in education should be devoted to the culture of the emotions and the establishment of worthy sentiments?

Reasoning. The whole literature of child psychology does not furnish a single satisfactory chapter on the subject of children's reasoning, and many writers on other topics pass the subject by entirely. The truth is that almost no scientific study has been made of this most important phase of child mind. Opinions as to children's capacity to reason range from statements that they can reason before they can talk to the extreme that they show only the germs of logical thinking at fifteen years (38, p. 5); from statements that the reasoning of children is entirely different from that of adults to statements that the difference is only one of degree. In no phase of child psychology, then, is it more dangerous to dogmatize; in none is further study more imperative.

Much, of course, depends upon the definition of the term. If by reasoning is meant a new organization of ideas for the purpose of effecting satisfactory adjustment to a new or problematic situation, it is evident that a store of ideas and images and some capacity to control them is necessary to such a process. In that case the infant must certainly lack the capacity to begin with. As Thorndike (46, p. 290) has well pointed out, "vague sense impressions and impulses make up his mental life." But very soon the multiplication of associations makes ideas and images stand

out. Given a large body of ideas, the instinct of mental activity insures comparison and thought about them, for "ideas carry within them the forces that make abstractions, feelings of similarity, judgments, and other characteristics of reasoning" (46, p. 292). In the sense in which we are using the term, therefore, it is entirely misleading to say that the reasoning capacity is undeveloped until puberty.

The child's inferiority in reasoning all must admit, for there are many adequate reasons for such inferiority. Poverty of experience and of ideas; the preponderance of sensational and affective elements in consciousness; domination by the instincts; greater susceptibility to suggestion; relative lack of control over the mental processes in general; ignorance of the many sources of error in thinking; vagueness of ends; incompleteness of concepts; total lack, during early years, of knowledge of the logical forms of thought, — these and many other limitations often make the *results* of a child's reasoning very different from those of the adult. What we wish to stress here is the fact that the *processes* are functionally the same in kind, though not in degree of accuracy and effectiveness. Certainly by the third year every normal child possesses and uses all the capacities and processes involved in adult reasoning. It is in the degree of success with which he uses them that he differs from his elders. His ideas are few; his concepts faulty; his premises often wrong; his capacity to evaluate ideas or to use analysis and synthesis very limited; his judgment untrained and unskillful; his capacity to hold attention and to direct the flow of consciousness to definite ends far below that of adults and, therefore, the results of his thinking appear to us "irrational," although arrived at by a true reasoning process. In spite of all these limitations children often reason well in particular types of

situation in which experience has reduced their effect to a minimum. To quote Miss Calkins, "the perverse and persistent confusion of children's undoubted ignorance of the world's ways with their alleged incapacity for thought and for serious feeling, is responsible for most of the mistakes we make in our dealings with them" (5, p. 395). The seriousness of the injustice lies in the fact that we allow or force the child to pass by innumerable opportunities to learn to reason by reasoning, or we fail to help him gain ideas, concepts, formulæ for thinking, and motives for their thoughtful use. Worse still, we impose upon his ignorance and actually teach him to reason incorrectly about many cause-and-effect and other relationships in nature and in human life.

Reasoning is no mysterious, lawless "faculty," given outright and to man alone, nor is it a capacity which bursts suddenly into full bloom at the dawn of adolescence. It is a highly complex set of mental processes by means of which the most difficult and most important new adjustments of man to his increasingly complex life are effected. It develops as other capacities do; its development is, indeed, dependent upon that of other functions of mind, — perception, association, memory, imagination, etc. Of the exact steps in this development, of the things which help and hinder it, of the means of its effective training we know, as yet, very little with certainty.

We know that the capacity for logical reasoning increases with age. There are reasons for thinking that the development is rhythmical, as many others are, with a decided acceleration at puberty. Perhaps it follows the course of a typical learning curve. We know that the reasoning of children is, as a rule, less direct, logical, orderly, less exact, less complete, less correct, and sometimes but **not necessarily slower, than that of adults. On the other**

hand, there are exceptions, in special cases, to almost every one of these statements. We know that practical and concrete reasoning and the use of analogy predominate over the use of abstract and logical formulæ; that concepts are psychological more often than logical. Tendencies of growth are in the direction of greater completeness, definiteness, consistency, accuracy, and a better understanding of the processes involved. Experience and training bring acquaintance with the abstract symbols and forms of logical thought and practice in their use, but even so the individual differences remaining between adults are quite as great as those between some children and some adults. Many grown persons never attain any great facility in the use of the higher logical processes except, perhaps, in some limited field.

Clear thinking and right acting were never more seriously demanded than in the present world crisis. Exact determination of the ways in which children reason in the many practical situations of life which they meet in the course of their development is greatly needed. Such information should have many suggestions as to proper direction of rational education. An effective education in rationality in all important phases of life would do more to advance the human race than any other one thing. Let us hope we shall soon have a serious attack upon this important problem, beginning with a thoroughgoing study of the reasoning processes of children.

Conclusion. In this and the preceding chapters we have attempted to introduce the reader to certain important phases of child psychology. We have aimed to leave the impression that this new science is just at its beginning, and that, therefore, on almost every important point, parents, teachers, and friends of children must keep an open mind, and at the same time continue to look to scientific

study of mental development for the solution of the practical and educational problems of child training. The thoughtful student cannot but have reached the conviction that the extent and accuracy of our knowledge differs widely in different parts of the field, and for different groups of years. Many gaps in our knowledge are now well recognized, many fields of investigation have been recently entered with prospect of valuable discovery ahead. The studies thus far made are quite sufficient to establish many significant facts which have already very materially affected our dealings with children. We are aware, as never before, of the vast individual differences between children of different ages and of the same age. We know far more than ever before of the quantitative nature of these differences. The studies thus far made are quite sufficient to establish similarly the differences between children and adults. It is clear that these differences are of *degree* rather than of *kind*, but they are none the less significant for that reason.

The trend of experimental findings is to the effect that it is futile to attempt to mark off stages of mental development in terms of definite chronological ages, since intelligence tests have clearly shown that it is "mental age" which chiefly determines the stage in which any capacity is likely to be found in a given individual or group of individuals. This, however, in no way minimizes the value of the proven fact that age differences in sense and perceptive capacity, attention, apperception, memory, association, imagination, emotional disposition, æsthetic and ethical appreciation, and reasoning are far too great to be ignored.

The present task of child psychology, which calls insistently for the patient and painstaking work of an army of trained investigators, is, in the main, to reveal to us, with exactness and completeness, the nature of these dif-

ferences; the correlations between them; the causes which underlie them; the effects they have upon the course of mental development; and the ways in which they are modified by experience, training, and instruction. An exact science of education awaits nothing so much as an exact science of child psychology. This must be its foundation and corner stone. We are compelled to leave the complete discussion of many of the problems hinted at in this book, and in this chapter particularly, to others. If we have with any degree of success paved the way for such discussion our task is done.

SUMMARY

1. The last two chapters have attempted, in the most fragmentary way, to introduce the student to the field of pure child psychology now so rapidly developing, in the hope that we may stimulate an interest in its further progress.
2. Each mental capacity follows a course of development somewhat parallel to, but not always closely correlated with, every other. Sense capacity, e.g., reaches maturity first; reasoning capacity develops more slowly, reaching maturity last and much later. When mental development is arrested the highest capacities suffer most serious impairment.
3. It should be constantly kept in mind that a child with serious sensory defects cannot sense keenly; that what has never been in sense experience can with difficulty be appreciated, if at all; that true imagery cannot be had for what has never been perceived in actuality; that the content of mind increases vastly in quantity and quality with age and experience; that those parts of mental content are vaguest and most useless in which experience has been most limited.

4. It is rapidly being demonstrated that individuals are endowed by nature with certain fundamental capacities which no amount of training can change to any appreciable extent, and that individuals differ vastly in their native endowment. Education may greatly improve the capacity to use native endowment; it cannot make good the defects of inheritance.
5. It is of the utmost importance in education that adequate means of determining the specific capacities of every child, at an early stage, be perfected and used, so that education may proceed rationally to make the most of those capacities which each has inherited.
6. There can be no denying that caution is needed in the application of the results of child psychology to education and to vocational guidance, and yet each year sees the approach of the day when both are to be placed upon a much surer footing than has been the case in any previous period of educational history. The principles of education and those of vocational guidance must both be derived from those of child psychology.

QUESTIONS AND TOPICS

1. Explain in detail why a rich and varied sensory experience is important.
2. Does rural life provide any better sensory-motor experience than city life? Why?
3. In the light of our knowledge of sensory and motor development, what criticism have you of the Montessori method?
4. Explain the expression "attention is a function of the content" of mind.
5. Under favorable conditions, recall the very earliest incident in your life that can now be brought to mind. Note your age at the time, the nature of the incident, the imagery involved, its clearness, your assurance that it is a true memory, etc.
6. What becomes of the memories of infancy and early childhood? Why?
7. Make careful introspective study of your own imagery, and compare your observations with those of other persons.

8. Make careful observations of the expression of emotions in children of different ages. Note what emotions are prominent, and the character, duration, intensity, etc., of their expression.
9. What significance has the fact that the fundamental sense capacities, native retentiveness, etc., are only to a small degree, if at all, affected by training, age, or sex?
10. What practical difference does it make whether we think of attention, memory, reason, etc., as "faculties" or as functions of mind?
11. State some of the practical and educational bearings of the vast individual differences in imagery, in memory, in reasoning capacity, etc.
12. Explain why the emotions often dominate conduct to a greater extent than reason.
13. Study examples of reasoning in some child of your acquaintance for evidence that it is the same in kind as that of the adult.
14. Select two or three children to whom you can give some exact tests of sense capacities, memory, association, reasoning, and the like. Compare the capacities of different individuals with each other and with yourself, and draw some tentative conclusions.

SELECTED BIBLIOGRAPHY

1. Barnes, E. *Studies in Education*. Vol. 1 (1896-97), 400 pp.; vol. 2 (1902), 400 pp.
2. Baldwin, J. M. *Mental Development in the Child and the Race*. (1906.) 477 pp.
3. Bonser, F. G. "The Reasoning Ability of Children"; in *Teachers College Cont. to Educ.* (1910.) No. 37, 134 pp. (Tests in fourth, fifth and sixth grades. Bibliography, pp. 113, 114.)
4. Brown, H. W. "Some Records of the Thoughts and Reasonings of Children"; in *Ped. Sem.*, vol. 2, pp. 358-96.
5. Calkins, Mary W. *An Introduction to Psychology*. (1901.) 511 pp.
8. Chamberlain, A. F. *The Child; A Study in the Evolution of Man*. (1901.) 498 pp.
- *7. Claparède, E. *Experimental Pedagogy and the Psychology of the Child*. (1911.) 332 pp.
8. Colvin, S. S., and Bagley, W. G. *Human Behavior; A First Book in Psychology for Teachers*. (1913.) 336 pp.
- *9. *Cyclopedia of Education*. Paul Monroe, editor. (1911-1913.)
Look under the head of the various topics of the chapter.
- *10. Dearborn, G. V. *Moto-sensory Development*. (1910.) 215 pp.
11. Dewey, J. *How We Think*. (1910.) 224 pp.
12. Drummond, W. B. *An Introduction to Child Study*. (1907.) 348 pp.
13. Ellison, Louise. "Children's Capacity for Abstract Thought as Shown by their Use of Language in Definition of Abstract Terms"; in *Am. Jour. of Psy.*, vol. 19, pp. 253-60.

14. Fisher, S. Carolyn. "Arithmetic and Reasoning in Children"; in *Ped. Sem.*, vol. 19, pp. 48-77. (Bibliography. Résumé of literature through 1911.)
15. Gesell, A. L., and Gesell, Beatrice C. *The Normal Child and Primary Education.* (1912.) 342 pp.
16. Gilbert, J. "Experiments on the Musical Sensitivity of Children"; in *Yale Psy. Lab. Studies*, vol. 1, pp. 80-87.
17. Hall, G. S. *Adolescence.* (1904.) 2 vols., 589 pp. and 784 pp.
18. Hall, G. S. *Aspects of Child Life and Education.* (1907.) 326 pp.
19. Hall, G. S. "Note on Early Memories"; in *Ped. Sem.*, vol. 6, pp. 485-512.
20. Hall, G. S. "Some Aspects of the Early Sense of Self"; in *Am. Jour. of Psy.*, vol. 9, pp. 351-95.
21. James, Wm. *Principles of Psychology.* (1890.) 2 vols. 689 pp. and 704 pp.
- *22. King, I. *The Psychology of Child Development.* (1903.) 265 pp.
- *23. Kirkpatrick, E. A. *Fundamentals of Child Study.* (1903.) 384 pp.
24. Kirkpatrick, E. A. *Genetic Psychology.* (1910.) 373 pp.
- *25. Kirkpatrick, E. A. *The Individual in the Making.* (1911.) 339 pp.
26. Major, D. R. *First Steps in Mental Growth.* (1906.) 360 pp.
27. McDougall, W. *An Introduction to Social Psychology.* (9th edition, 1915.) 431 pp.
28. Meumann, E. *The Psychology of Learning.* (1913.) 393 pp.
29. Montessori, Maria. *The Montessori Method* (1912), pp. 167-245.
30. O'Shea, M. V. *Social Development and Education.* (1909.) 561 pp.
- *31. Parmelee, M. F. *The Science of Human Behavior* (1913), pp. 256-326.
- *32. Partridge, G. E. *Genetic Philosophy of Education* (1912), pp. 14-87.
An epitome of G. Stanley Hall's writings, with a bibliography of them.
33. Partridge, G. E. *Outline of Individual Study.* (1910.) 240 pp.
34. Preyer, W. *The Mind of the Child.* Part I: *The Senses and the Will.* (1888.) 346 pp. Part II: *The Development of the Intellect.* (1889.) 317 pp.
35. Preyer, W. *Infant Mind.* (1899.) 176 pp.
36. Pyle, W. H. *The Outlines of Educational Psychology.* (1912.) 276 pp.
37. Pyle, W. H. *The Science of Human Nature.* (1917.) 229 pp.
- *38. Rusk, R. R. *Introduction to Experimental Education.* (1912.) 303 pp.
- *39. Sandiford, P. *The Mental and Physical Life of School Children.* (1913.) 346 pp.
40. Seashore, C. E. "The Measurement of Pitch Discrimination; A Preliminary Report"; in *Psy. Monographs*, vol. 13, pp. 21-60.
- *41. Shinn, Millicent W. *Biography of a Baby.* (1900.) 247 pp.
42. Slaughter, J. W. *The Adolescent.* (1912.) 100 pp.
- *43. Tanner, Amy. *The Child.* (2d edition, 1915.) 533 pp.
44. Thorndike, E. L. "Notes on Child Study"; in *Col. Univ. Cont. to Phil. Psy. and Educ.*, vol. 8, nos. 3 and 4. (1901.) 157 pp.

45. Thorndike, E. L. *Educational Psychology; Briefer Course.* (1914.) 442 pp.
46. Thorndike, E. L. *Animal Intelligence.* (1911.) 297 pp.
47. Titchener, E. B. *A Textbook of Psychology.* (1911.) 565 pp.
- *48. Tracy, F., and Stimpfl, J. *The Psychology of Childhood.* (1909.) 219 pp.
49. Waddell, C. W., and Root, W. T. *A Syllabus and Bibliography of Child Study.* (1915.) 98 pp.
50. Watt, H. J. *The Economy and Training of Memory.* (1911.) 128 pp.
- *51. Whipple, G. M. *Manual of Mental and Physical Tests.* Part I: *Simpler Processes.* (1914.) 365 pp. Part II: *Complex Processes.* (1914.) 336 pp.
52. Yerkes, R. M. *Introduction to Psychology* (1911), pp. 211-44.

NOTE. Any standard textbook on general psychology may be consulted for description and analysis of the mental processes of the adult.

SUGGESTIONS

FOR A TEACHER'S PRIVATE LIBRARY IN CHILD PSYCHOLOGY AND RELATED TOPICS

1. Chamberlain, A. F. *The Child*. Scribners. (1900.) 498 pp. (Exhaustive bibliography.)
An epitome of child-study literature to 1903 by an anthropologist.
2. Forbush, W. B. *Child Study and Child Training*. Scribners. (1915.) 319 pp.
A guide to child study and training for parents and teachers.
3. Hall, G. S. *Youth: Its Education, Regimen, and Hygiene*. Appleton. (1912.) 379 pp.
A condensation of his large work on adolescence.
4. Hall, G. S., and others. *Aspects of Child Life and Education*. Ginn. (1907.) 326 pp.
Some of the best studies typical of the early child study.
5. Johnson, G. E. *Education by Plays and Games*. Ginn. (1907.) 234 pp.
A practical handbook of games and plays suited to each age.
6. Kirkpatrick, E. A. *The Individual in the Making*. Houghton Mifflin Company. (1911.) 339 pp.
A subjective view of child development with suggestions to parents.
7. Mangold, G. B. *Problems of Child Welfare*. Macmillan. (1914.) 522 pp.
A comprehensive treatment of the most important child welfare problems.
8. Monroe, W. S., De Voss, J. C., and Kelly, T. J. *Educational Tests and Measurements*. Houghton Mifflin Company. (1917.) 309 pp.
Studies of the school work of children.
9. Mumford, Edith M. *The Dawn of Character*. Longmans. (1914.) 210 pp.
A practical study of child life and training.
10. Parmelee, M. *The Science of Human Behavior*. Macmillan. (1913.) 443 pp.
Biological and psychological foundations clearly presented.

11. Partridge, G. E. *A Genetic Philosophy of Education*. Sturgis and Walton. (1912.) 401 pp.
An epitome of G. Stanley Hall's views on child psychology in relation to education.
12. Puffer, J. A. *The Boy and his Gang*. Houghton Mifflin Company. (1912.) 187 pp.
An excellent presentation of the meaning, values, and dangers of the gang.
13. Rusk, R. R. *Introduction to Experimental Education*. Longmans. (1912.) 303 pp.
Applications of child psychology to educational practice.
14. Shinn, M. W. *The Biography of a Baby*. Houghton Mifflin Company. (1900.) 247 pp.
The developments of an infant during the first year.
15. Terman, L. M. *The Hygiene of the School Child*. Houghton Mifflin Company. (1914.) 417 pp.
A helpful discussion of growth, physical defects, and health care.
16. Terman, L. M. *The Measurement of Intelligence*. Houghton Mifflin Company. (1916.) 362 pp.
The best discussion of the aims, values, and administration of intelligence tests.
17. Thorndike, E. L. *Educational Psychology*. Teachers College. (1916.) 442 pp.
A biological psychology applied to education.
18. Tracy, F., and Stimpfl, J. *The Psychology of Childhood*. Heath. (1909.) 219 pp.
One of the best of the early books.
19. Tyler, J. M. *Growth and Education*. Houghton Mifflin Company. (1907.) 294 pp. (Bibliographies.)
A helpful and stimulating treatment of the growth problems involved in education.
20. Watt, H. J. *The Economy and Training of Memory*. Longmans. (1909.) 128 pp.
A very practical treatment of an important topic.
21. Whipple, G. M. *Manual of Mental and Physical Tests*. Warwick and York. Vol. I (1914), 365 pp., vol. II (1915), 336 pp.
The best discussion of tests other than those of the Binet type.

GLOSSARY

- acquired character**, a physical or mental trait the cause of which is to be found in the life history of the organism rather than in heredity.
- adaptation**, a process of adjustment to environmental changes.
- anthropology**, the science of man.
- atavism**, a reversion to the traits of earlier generations.
- behavior**, the sum total of all the responses of an organism.
- biophor**, a primary unit of the germ plasm or hereditary substance.
- catharsis**, purgation, cleansing or ridding body or mind of certain traits or tendencies.
- chromosomes**, minute, V-shaped, structural elements of the cell thought to be the bearers of hereditary qualities.
- clinical method**, a method of examination or demonstration of a case in presence of a group.
- correlation**, mutual or reciprocal relationship between two capacities or functions.
- culture epoch theory**, the pedagogical correlate of the recapitulation theory; the theory that each child must traverse from the beginning all the stages of racial culture history.
- delinquent**, a child, under the age of legal responsibility, who violates any law.
- determinant**, a secondary unit of germ plasm composed of biophors and regulating the origin of cells or groups of cells.
- dominant trait**, one tending to become characteristic of the species.
- embryology**, the science dealing with the development of the embryo.
- environment**, the sum total of all conditions that actively influence the development of any organism from without.
- etiology**, an inquiry into the effective causes of phenomena.
- eugenics**, the science of improvement of the human race by application of the laws of heredity.
- euthenics**, the science of improvement of the human race through controllable environment.
- evolution**, in biology, the theory that all higher have originated from lower forms of life by a process of gradual adaptive change.
- feeble-minded**, a general term applied to all those whose mental development is seriously retarded or arrested at a level three or more years below that proper for their age.
- fœtus**, a term applied to the embryo after the second month.
- genetic**, pertaining to the origin or beginnings of phenomena.
- germinal selection**, a process of selective struggle for nutriment.

- within the germ cell, postulated by Weismann as the basis of in-born variations.
- germ plasm**, that part of the cell-protoplasm by means of which life is passed on from parent to offspring; the hereditary substance.
- heredity**, the tendency of an organism to develop likeness to its progenitors.
- id**, a theoretical component of germ plasm composed of determinants and supposed to give origin to definite parts of an organism.
- idiot**, the lowest class of feeble-minded whose mentality never exceeds the three-year level.
- imbecile**, the feeble-minded of middle grade whose intelligence never exceeds that of the normal seven-year-old child.
- inborn**, a capacity, character, or trait whose sufficient cause is inherent in the germ plasm.
- innate**, implanted by nature; inborn.
- instinct**, see pp. 100 ff.
- intelligence**, the capacity to make improved adaptations to environment by the intervention of mental processes.
- limen**, the point at which a sensory stimulus, or the difference between two stimuli, is just recognizable; the sensory or discrimination threshold.
- mean**, the statistical or arithmetical average.
- median**, the middle or representative value in a statistical series.
- Mendelism**, the theory of Mendel (p. 76).
- mental age**, that measured by the level of intelligence as distinct from real or chronological age.
- mitosis**, the process of cell division and multiplication.
- mode**, the commonest or most frequent value in a statistical series.
- moron**, the highest type of feeble-minded, representing mental ages of from seven to twelve years.
- mutant**, an individual organism undergoing the process of mutation.
- mutation**, a process of sudden occurrence of a large, discontinuous variation which is hereditary from the first.
- nascent**, beginning to exist or develop.
- natural selection**, a process of selection in which the laws of nature are the selective agents.
- neuron**, the nerve cell with its attached fiber considered as a structural unit.
- neurosis**, a change in nerve tissue.
- onomatopœia**, the principle by which words are formed in imitation of natural sounds.
- ontogeny**, the history of the evolution of the individual organism.
- ovum**, the germ cell of the female.
- paleontology**, the study of the science of antiquities.
- parallelism**, in psychology, the theory that mental processes accompany neural processes.
- paresis**, partial paralysis affecting movement but not sensation.
- phylogeny**, the history of the evolution of a species.
- plateau**, a stage in learning in which progress is temporarily checked;

- a part of a curve of learning which approaches the level.
- prenatal**, embryonic; that which precedes birth.
- psycho-analysis**, a method of treatment of functional mental disorders.
- psychosis**, a mental process or change.
- questionnaire**, a group of related questions on a single topic.
- recapitulation theory**, the theory that the physical and mental development of an individual repeats in approximately the same order the stages in the evolution of the species.
- recessive trait**, one tending to disappear from the species.
- recidivist**, a repeated offender.
- spermatozoön**, the germ cell of the male.
- syphilis**, a specific, infectious, venereal disease.
- teleology**, the theory that all things come into existence for definite ends.
- telepathy**, the supposed (?) sympathetic affection of one mind by another without direct communication by the senses.
- tropism**, a simple mechanical or chemo-physical response of an organism to stimulation.

INDEX OF SUBJECTS

- Abstract concepts, increase of, 286; formed with difficulty, 294 ff.
- Accuracy, of sense-perception, 280; of reasoning, 294 ff.
- Acquired characters, inheritance of, 79 ff.
- Acquisitiveness, 99, 216 ff.
- Activity, motor, of children, innate physical, 115; innate mental, 118; linguistic, of one day, 173; in relation to mental development, 258.
- Adaptation, process of, 55.
- Adenoids, 242.
- Adolescence, the emotions of, 109; the play of, 140 ff.; speech tendencies at, 162 ff.; aesthetic interests at, 195; moral development at, 215; prominence of delinquent tendencies at, 243 ff., 247.
- Adults, and children compared, 109, 139; imitation of, in child play, 147.
- Æsthetic sensitivity, beginnings of, 186; in primitive men, 187 ff.; increase of, at adolescence, 195; an aim in art education, 205.
- Affection, as a feeling element, 290.
- Age, effect of, on plays, 134 ff.
- Alcohol, effects of, on the embryo, 69; effects of, on heredity, 81.
- Amœba, 58.
- Amusements, 123, 140.
- Anger, 98, 108 ff.
- Animals, classes of, 57; similarity of embryonic stages in, 64 ff.; nervous system of, 97; instincts of, and those of man, 105; play of, 129; speech of, 153 ff.
- Anthropological studies of children, 6 ff.
- Approval, 211.
- Arrest of development, in relation to delinquency, 228 ff., 245, 247.
- Art. *See* Drawing.
- Association, the process of, 283 ff.
- Atavism, 281 ff.
- Automatic movements, 98.
- Babbling, prelinguistic, 160.
- Baby-talk, detrimental, 162, 180.
- Bad, the child not, by nature, 209 ff.; ideas of good and, 214 ff.; 235 ff.
- Bailey and Babette Gatzert Foundation, 26.
- Ball, plays with, 135.
- Baseball, psychological basis of interest in, 133.
- Behavior, problems of, 94; chemo-physical basis of, 95; structural basis of, 95; evolution of, 96; human, 97 ff.; types of, in the child, 216; relation of mind to, 258 ff., 266 ff.
- Bibliographies. *See* ends of chapters.
- Binet-Simon tests, 42, 232 ff.
- Biographies, baby, 17.
- Biographical method, 31.
- Body, and mind, 71, 94, 258.
- Boys, play interests of, 135 ff.; speech of, 175; art work of, 200 ff.; delinquencies of, 246 ff.
- Boy Scouts, 249.
- Bullying, and teasing, 222.
- Camp-Fire Girls, 249.
- Cannibalism, 7-8.
- Cell, the theory of, 57; fertilization of, 60 ff.; parent, 61; division of, 62.
- Child, the: new evaluation of, 1 ff.; in folk-thought, 4; in history, 6 ff.
- Child, The Conference for Research and Welfare, 24.
- Child psychology, the task of, 297 ff.
- Child study, significance of, 1; literature of, 17 ff.; Hall, the "Fa-

- ther" of, 15; Rousseau and, 15; basis of education, 16; history of, 17 ff.; societies for, 18 ff.; the movement for, 18; in foreign countries, 21 ff.; journals on, 22; accomplishments of, 45.
- Child-Welfare, Society for, in England, 11 ff.; the beginnings of, 23; exhibits, 25; commissions on, 25.
- Children, mutilation and abuse of, 9, 11 ff.; slavery of, 10 ff.; and the school, 13 ff.; methods of studying, 30 ff.; contents of the minds of, 32 ff.; in the light of evolution, 51 ff.; the instincts of, 94 ff.; the play of, 123 ff.; the linguistic development of, 153; the drawings of, 185; the moral nature of, 209 ff.; the delinquencies of, 226 ff.; the general mental development of, 255 ff.
- Children's Bureau, the, establishment of, 25; work of, in study of infancy, 27, 68.
- Children's drawings, 185 ff.
- Children's Institute, 24.
- Chromosome theory, 57.
- Chromosomes, number of, 60; division of, 61 ff.
- Clinics, psychological, 24, 26.
- Clinical method, 34.
- Clubs, 140, 249.
- Color, interest in, 201.
- Collecting, 216.
- Companionship, 119, 138.
- Competition, in play, 138 ff.
- Consciousness, beginnings of, 259 ff.; prenatal, 261; in the new-born, 263; descriptions of infant, 263 ff.; functions of, 266 ff.
- Constructiveness, and destructiveness, 19, 117; in play, 138; in art, 185, 201, 203.
- Correlation, of curiosity and intelligence, 117; of motor with other capacities, 202 ff.; of attention with intelligence, 282.
- Cries, as origin of speech, 155, 158, 159.
- Cruelty, to children, 6 ff.; of children, 218, 222.
- Culture epoch theory, 67, 273.
- Curiosity, and truancy, 116 ff.; and morality, 218.
- Customs, and morality, 210 ff.
- Darwin, the problem of, 52 ff.; the gemmule theory of, 75; and acquired characters, 79; theory applied to mind, 256.
- Defects, mental and speech, 175 ff.; physical, and delinquency, 242; mental, and delinquency, 237 ff.
- Definitions, by children, 170 ff.
- Delinquency, juvenile, 226 ff.; inheritance of, 86 ff.; definition of, 226; causes of, 227 ff.; heredity and, 228 ff., 237; instinct and, 231 ff.; feeble-mindedness and, 237 ff.; the home and, 237; child labor and, 237 ff.; idleness and, 239; the gang and, 240 ff.; responsibility of society for, 241 ff.; physical defects and, 242; age and, 243 ff.; nature of, 245 ff.; remedies for, 248 ff.
- Delinquent, the typical, 247-48.
- Depravity, the doctrine of natural, 210; of delinquent denied, 227, 230.
- Descartes, the principle of, 45 ff.
- Descent, the theory of, 52; evidences of, 53.
- Development, arrest of, 228 ff.; 247.
- Discrimination, capacity for, 279.
- Doll play, 139, 141.
- Dramatic play, 128, 138, 148.
- Drawing, children's, 185 ff.; instinctive basis of, 185-86; and writing, 188; studies of, 189 ff.; genetic stages in, 190 ff.; scribbling, 190-92; artistic illusion, 192-94; self-conscious period, 194; rebirth of ability, 195; subjects drawn, 195 ff.; a form of linguistic expression, 196-97; of man, 196 ff.; characteristics of, 197 ff.; line *vs.* mass, 198; symbolism of, 198; and thought, 200; sex differences in, 200 ff.; individual differences in, 202 ff.; course of study in, 202-

- 03; values of, 203 ff.; cathartic effect of, 204; aims of teaching, 204-05; summary, 205-06.
- Economy, doctrine of, 45.
- Edwards-Tuttle family, 86.
- Emboitement theory, 56.
- Embryo, development of, 65.
- Emotions, and instincts, 108 ff.; evolution of, 289 ff.; of children and adults contrasted, 290 ff.; expression of, 291.
- Entoderm, and its derivatives, 64.
- Environment, *vs.* heredity, 81, 228; effect of, on speech, 172; as cause of delinquency, 237 ff.
- Eugenics, 237, 249.
- Evolution, principle of, 51; evidences for, 53; factors in, 54 ff.
- Experimental method, 47.
- Expression, instinctive, 97 ff.; variety of, in play, 137 ff.; in speech, 158 ff.; in drawing, 193 ff.
- Fear, 98.
- Feeble-mindedness, and speech, 174 ff.; and ability in drawing, 203; and delinquency, 232 ff.; effect of, on accountability, 235.
- Fittest, survival of, 54.
- Fetus, 66.
- Galton's laws, 78 ff.
- Games, absence of, in infancy, 137; culmination of interest in, at adolescence, 139 ff.; prominence of certain types of, 142.
- Gang, the, 240 ff.
- Genetic view of play, 130; stages in speech, 158 ff.; in drawing, 190 ff.; view of moral nature, 209 ff.; account of mind, 255 ff.
- Germ cells, relation to the soma, 74, 77.
- Germ plasm, continuity of, 74 ff.; isolation of, 81.
- Gianini, Jean, the case of, 234.
- Girls, play interests of, 135; compared with those of boys, 141 ff.; speech development of, compared with that of boys, 175; drawings of, compared with those of boys, 301 ff.; delinquencies of, 246.
- Good and bad in child nature, 209 ff.
- Gregariousness, 119; and speech, 158; and bad habits, 223.
- Group, in play, 139 ff.
- Growth, the principle of, in mental development, 271.
- Habit, relation of, to instincts, 98 ff., 113.
- Handwriting, and drawing, 188.
- Health, and play, 148.
- Heredity, 71 ff.; prenatal influences on, 67; individual, 71; racial, 71; definition of, 72; inevitableness of, 73; theories of, 74 ff.; recapitulation and, 78; scientific studies of, 82 ff.; Wood's views on, 83 ff.; Galton's views on, 84; Thorndike's studies of twins, 85; Cattell's studies of, 85 ff.; Healy on, 86; social, 88 ff.; shown in instincts, 94 ff.; and the forms of play, 130 ff.; and speech, 157-58; and art expression, 186 ff.; and morality, 212; and delinquency, 228 ff.; mental capacity and, 232, 260 ff.
- Home, the defective and delinquency, 237.
- Human behavior, classes of, 97.
- Human sacrifices, 8-9.
- Ideals, children's, 33.
- Ideo-plasm, theory of, 56.
- Imagery, types of, 287; individual differences in, 287.
- Imagination, development of, 288; tests of, 288.
- Imitation, in play, 138 ff.; in learning to speak, 157, 160; of copy in drawing, 191; and morality, 222.
- Immorality, typical offense of girls, 246.
- Individual differences, in drawing, 202 ff.; in mental development, 275; in imagery, 287.
- Infancy, studies of, 31; meaning of, 107; plays in, 137; speech in, 159; drawing in, 190; the moral nature

- in, 214; consciousness in, 263 ff.; memory in, 285; imagination in, 288.
- Infant mortality, 68.
- Infanticide, 6-7.
- Inheritance. *See* Heredity.
- Innate ideas, 260.
- Insanity, 237.
- Instincts, illustrated, 99 ff.; nature of, 100 ff.; defined, 101; stimuli of, 102 ff.; human, characterized, 103 ff.; complexity of human, 106; inadequacy of human, 107; emotions and, 108 ff.; classification of, 110 ff.; pedagogical significance of, 108, 112 ff.; treatment of, 113 ff.; some useful, 115 ff.; general physical activity, 115; curiosity, 116; general mental activity, 118; social, 119; in relation to play, 126, 128, 136, 139, 148; in relation to speech, 158 ff.; in relation to art expression, 185 ff.; and morality, 209 ff.; and delinquency, 231 ff.; and mental origins, 257 ff.
- Intelligence tests, purposes of, 42; values of, 43 ff.
- Interest, and curiosity, 116 ff.; in plays, 133 ff.; in drawing, 186, 195 ff.
- Interpretation, cautions in scientific, 44 ff.
- Journals, devoted to child study, 22.
- Jukes family, 87.
- Juvenile courts, 23, 249.
- Kallikak families, 87 ff.
- Language. *See* Speech.
- Learning, stages in, of speech, 159 ff.: of drawing, 190 ff.; laws of, 275 ff.
- Lies, children's, 220.
- Limen, the stimulus and difference in children, 279 ff.
- Man, drawings of, by children, 198 ff.
- Mean, the, 39.
- Median, the, 40.
- Memories, early, 285 ff.
- Memory, development of capacity of, 284 ff.; character of, in infant, 285.
- Mendelism, 76.
- Mental development, through play, 145 ff.; through speech, 174; revealed in drawing, 200; by means of drawing, 203 ff.; periods of, 269 ff.; general principles of, 271 ff.; orderliness of, 271 ff.; recapitulation in, 272 ff.; periodicity in, 273; continuity in, 274; self-activity the sole means of, 274; individual differences in, 275.
- Mesoderm, and its derivatives, 64.
- Methods, scientific, characterized, 31; value of, 30, 48; kinds of, 30; biographical, 31; direct question, 32; clinical, 34; questionnaire, 35; statistical, 38 ff.; parallel groups, 41 ff.; intelligence tests, 42 ff.; introspective, observational, psychoanalysis, association, and laboratory, 47; difficulty of, 47 ff.; improvements in, 48.
- Meumann's principle, 46.
- Mind, contents of, in children, 32 ff.; and body, 119, 258; general development of, 255 ff.; problems of, 255; nature of, 256; origin of, 257; and movement, 258 ff.; partly predetermined, 260; unitary nature of, 267 ff.
- Mitosis, process of, 62 ff.
- Mode, the, 40.
- Moral nature, of children, 209 ff.; point of view, 209 ff.; and instincts, 209, 211, 213, 231 ff.; evolution of, 210, 221; social nature of, 211; heredity and, 212; stages in development of, 214 ff.; in infancy, 214; in early childhood, 214; in later childhood, 215; at adolescence, 215; in later adolescence, 216; effect of changed views of, 226 ff.; feeble-mindedness and, 233 ff.; intelligence and, 235 ff.
- Motor activity of children, 137, 139.
- Movements, genesis of, 95 ff., 100 ff.; instinctive basis of, 115; involved in speech, 156 ff.; interest in, 191; and origin of mind, 257 ff.

- Nascent periods, of instincts, 104;**
intellectual, 118.
- Neuron, the, and behavior, 96 ff.**
- Obstinacy, 220 ff.**
- Ontogeny, 51, 58.**
- Origins, racial, of play, 130 ff.; of**
speech, 154 ff.; of art, 186 ff.
- Ovum, appearance of, 59; size of,**
60; development of, after fertiliza-
tion, 60 ff.
- Ownership, the sense of, 216 ff.**
- Oxnam, Charles, the case of, 235.**
- Pangensis theory, 56.**
- Parallel groups, method of, 41 ff.**
- Parent cell, the, 61.**
- Parts, and organs, development of, 64.**
- Perceptions, first appearance of, in**
behavior, 265.
- Periodicity, of instincts, 106.**
- Phylogeny, study of, 51 ff.**
- Plasticity, of infancy, 105.**
- Plateau, a stage in learning of**
speech, 160; of drawing, 194.
- Play, 123 ff.; compared with work,**
123; defined, 123 ff.; theories of,
125 ff.; Schiller-Spencer theory of,
126 ff.; Groos theory of, 127 ff.;
instinctive basis of, 126, 128, 136,
139, 148; the recapitulation theo-
ry of, 130 ff.; the relaxation
theory of, 131 ff.; the varieties of,
133 ff.; effect of age on, 134 ff.;
in infancy, 137; in early childhood,
137 ff.; in later childhood, 138 ff.;
in adolescence, 140 ff.; socializa-
tion through, 140; sex differences
in, 140 ff.; racial elements in, 144
ff.; values of, 145; dramatization
and imitation in, 147; linguistic,
160; impulse and delinquency,
231 ff., 239 ff.; as remedy for de-
linquency, 249.
- Predatory activities, 241.**
- Prenatal influences, 67 ff.**
- Primitive, in play, 139 ff.; in art,**
186 ff.; in morality, 217, 229 ff.
- Psycho-analysis, 212.**
- Psychologist's fallacy, 45.**
- Psychosis, 256.**
- Question, the method of the direct,**
32 ff.
- Questionnaire, defense of, 27 ff.; the**
method, 35 ff.; criticism of, 35 ff.;
typical topics studied by, 38.
- Racial traits, in play, 127 ff.; in**
language, 144; in drawing, 186 ff.;
in mental origins, 256 ff.
- Reasoning, development of, in chil-**
dren, 293 ff.
- Recapitulation, physical, 64 ff.;**
heredity and, 78; instincts and,
104 ff.; in play, 130 ff.; in drawing,
186 ff.; in mental development,
260, 272 ff.
- Reflexes, illustrated and defined,**
98 ff.; organic, 98.
- Reproduction, process of, 58 ff.**
- Research, laboratories, 26; Buckel**
Foundation, 26; in the University
of Iowa, 26.
- Responsibility, changes in, with age,**
214 ff.; and will training, 220 ff.;
lack of, in children, 227, 245; in
feeble-minded, 235 ff.
- School, and the child, 13 ff.**
- Scientific ability, heredity of, 85 ff.**
- Scientific study of children. See**
Methods.
- Scribbling, 190 ff.**
- Selection, germinal, 75 ff.; natural,**
53, 55.
- Self-activity, the sole means of de-**
velopment, 274.
- Sense-perception, development of,**
279 ff.
- Senses, the beginning of the func-**
tioning of, 261 ff.; order of devel-
opment of, 262.
- Sentence, the use of the, by children,**
166, 172 ff.
- Sex differences, in play, 141 ff.; in**
speech, 175; in drawing, 200 ff.;
in delinquency, 246.
- Slang, 162 ff.**
- Slavery, of children, 10 ff.**
- Social, instinct, 119; element in play,**
142 ff.; in speech, 158, 171 ff.; na-
ture of morality, 211 ff., 217; re-

- sponsibility for delinquency, 241; remedies for delinquency, 248 ff.
- Socialization, through play, 140, 147 ff.
- Societies, for study of children, 18 ff.
- Species, origin of, 54.
- Speech, defined, 153; in animals, 153 ff.; importance of, 154; origin of, 154; ontogeny of, 156 ff.; physiological basis of, 156; heredity and, 157; stages in development of, 159 ff.; extent of use of, 173; and intelligence, 174 ff.; development of, in the feeble-minded, 174 ff., 177 ff.; summary, 179 ff.
- Spermatozoön, 59.
- Statistical, method, 38 ff.; terms, 39 ff.; studies in heredity, 81 ff.; studies in play, 133 ff.; studies of vocabularies, 163 ff.; studies of feeble-mindedness, 233 ff.; studies of the causes of delinquency, 237 ff.
- Talent, early development of, in art, 202.
- Teasing and bullying, 222.
- Teleology, argument from, 46.
- Telepathy, 69.
- Theft, natural result of development of desire for ownership, 216 ff.; in primitive times, 230; typical offense of boys, 246.
- Tropisms, 95.
- Truancy, 218 ff.; instinctive basis of, 219; cathartic effect of, 219.
- Twins, Thorndike's study of heredity in, 85.
- Variation, theories of, 74.
- Vocabularies, studies of children's, 163 ff.; tests of, 176 ff.
- Vocational guidance, 240, 249.
- Welfare of children. *See* Child-welfare.
- Words, a child's first, 158; average number of, in a child's vocabulary, 166; the use of, for sentences, 166; definitions of, by children, 170; the content of, 171 ff.; number of, in sentences used by children, 173; number used per day, 173 ff.; number used by the feeble-minded, 176; tests, 177.
- Work, compared with play, 123 ff.

INDEX OF NAMES

- Abbott, Miss E., 237, 246.
 Addams, Miss Jane, 231 ff., 239.
 Aristotle, 5, 146.
- Baer, von, K. E., 66.
 Baldwin, J. M., 191, 281.
 Barnes, E., 20, 22, 33, 170, 171, 178,
 192, 193, 196, 197, 198, 288.
 Barnett, Mrs. M. G., 231.
 Bell, S., 174.
 Binet, A., 42, 170, 178, 179, 232, 233.
 Bohannon, E. W., 148, 221.
 Bonger, W. A., 11 ff., 230, 238,
 242.
 Bonnet, C., 56.
 Boyd, W., 169.
 Brandenburg, G. C., 168, 173, 174.
 Breckenridge, Miss S. P., 237, 246.
 Bridgman, Laura, 277.
 Brinton, D. C., 3, 124.
 Brown, E. E., 189, 197.
 Burk, Mrs. C. F., 216.
 Burk, F., 222.
 Burnham, W. H., 202, 204.
- Calkins, Miss M. W., 295.
 Carr, H. A., 145, 146, 148.
 Castle, W. E., 72.
 Cattell, J. McK., 85.
 Chamberlain, A. F., 2, 4, 12, 154,
 155, 170, 186, 193, 194, 205.
 Chambers, W. G., 35, 125, 171.
 Chase, J. H., 133.
 Chrisman, O., 161.
 Claparède, E., 18, 35.
 Clopper, E. N., 237.
 Comenius, J. A., 16.
 Confucius, 5.
- Conklin, E. G., 71, 73, 81.
 Conradi, E., 162.
 Crabbe, G., 14.
 Crosswell, T. R., 184, 185, 142, 144.
 Curtis, Miss E. W., 147.
- Darrah, Miss E. M., 217 ff.
 Darwin, Charles, 52 ff., 75, 76, 77,
 79, 83, 256.
 Davenport, C. B., 80, 86, 95, 219.
 Dawson, G. E., 229.
 Dearborn, G. V., 17, 31, 201.
 Derver, J., 172, 177.
 Descartes, R., 46.
 De Vries, H., 77.
 Dewey, J., 123, 147, 270.
 Dickens, Charles, 11, 14.
 Doran, E. W., 163.
 Drew, A., 239.
 Drummond, W. B., 31, 65.
- Ebbinghaus, H., 289.
 Ellis, A. C., 135.
 Ellis, H., 4.
 Ellison, A. C., 178.
- Fiske, John, 107.
 Flanders, Miss C., 196, 197.
 France, C. J., 216.
 Freud, S., 212.
 Froebel, F., 15.
- Gale, M. C. and H., 174.
 Galton, F., 56, 78, 83, 84.
 Garafalo, R., 228.
 Garner, R. L., 156.
 Gault, R. H., 35.
 Gesell, A. L. and Mrs. B. C., 18.

- Goddard, H. H., 76, 86, 87, 88, 232, 233, 235 ff.
 Goldmark, Miss J., 240.
 Goring, C., 242.
 Grant, J. R., 163.
 Gross, K., 127-30, 143, 147.
 Gulick, L., 144.

 Haeckel, E., 66.
 Hale, H., 162.
 Hall, G. Stanley, 3, 4, 18 ff., 22, 24, 32, 35, 37, 51, 67, 84, 102, 109, 117, 118, 123, 124, 129, 130, 131, 135, 143, 147, 171, 186, 190, 201, 202, 203, 205, 218, 220, 246, 256, 268, 285, 290 ff.
 Hammurabi, 9.
 Hart, H. H., 23.
 Healy, W., 68, 86, 228, 242 ff.
 Henri, V., 155.
 Herbart, J. F., 15, 67.
 Hogan, Mrs. L. E., 189.
 Holmes, A., 111.

 Ivanoff, E., 203.

 James, W., 112, 113, 263, 284.
 Jastrow, J., 201.
 Jesus, 3, 5.
 Johnson, G. E., 123, 124, 133, 136 ff.
 Johnson, J., 217.
 Jordan, D. S., 189.
 Judd, C. H., 154.
 "Jukes, Max," 87.
 Jung, C. G., 212.

 Katzeroff, D., 201.
 Keller, Helen, 277.
 Kerschensteiner, G., 189, 200, 201, 202, 205.
 Kidd, D., 2.
 Kik, C., 203.
 King, I., 265 ff., 269.
 Kirkpatrick, E. A., 111, 168.
 Kline, L. W., 216, 219.

 Krohn, W. O., 19.
 Kussmaul, A., 17.

 Lacassagne, 241.
 Lamareck, de, J. B., 52, 79.
 Lay, W. A., 201, 202.
 Lee, J., 139.
 Lefevre, A., 155.
 Levinstein, S., 186, 201.
 Lindsey, B. B., 241.
 Lobisch, 17.
 Locke, John, 15.
 Loeb, J., 101.
 Lombroso, C., 227, 228, 229.
 Lukens, H. T., 166, 167, 172, 189, 190, 191, 193, 194, 196, 197, 199, 204.

 Major, D. R., 137, 172, 189, 190, 191, 261, 285.
 Mark, T., 110.
 Marro, A., 244.
 McDougall, W., 101, 102, 108, 116, 292 ff.
 McGhee, Z., 142, 143.
 McMurry, C. A., 19.
 Mead, C. D., 174, 175.
 Melville, A. H., 162.
 Mendel, J. G., 76.
 Meumann, E., 46, 284.
 Monroe, W. S., 40.
 Montessori, Maria, 282.
 Moore, Mrs. K., 168, 169, 173.
 Morgan, C. L., 45.
 Morrison, W. D., 227, 232, 240.
 Müller, F., 66.

 Nagali, C. von, 56.
 Nearing, S., 238.
 Nice, Mrs. M. M., 172.

 Ogden, R. M., 178.
 Oppenheim, N., 243.

 Parker, F. W., 19.
 Parmelee, M., 34, 118, 123, 124, 267.

- Partridge, G. E., 197, 223, 273, 290.
 Patrick, G. T. W., 124, 129, 131, 132,
 133, 143, 145, 239.
 Payne, G. H., 2, 6 ff.
 Pelsma, J. R., 159, 163, 164.
 Pestalozzi, J. H., 15, 17.
 Plato, 5, 15, 149.
 Ploss, Dr., 2.
 Powell, J. W., 106.
 Prentiss, C. W., 63 ff.
 Preyer, W., 17, 31, 32, 145, 261.
 Puffer, J. A., 219, 240, 241.
- Ricci, C., 189.
 Riis, J., 231, 240.
 Roosevelt, T. R., 24.
 Root, W. T., x.
 Rousseau, J. J., 15.
 Rugg, H. O., 40.
 Rusk, R. R., 40, 284.
 Russell, E. H., 18.
- Sandiford, P., 83.
 Schiller, F., 126.
 Schleiden, M. J., 57.
 Schoff, Mrs. H. K., 218, 237.
 Schuyten, M. C., 197, 201.
 Schwann, Th., 57.
 Seashore, C., 26, 280.
 Sechrist, F. K., 162.
 Shaw, J. C., 170, 178.
 Sheldon, H. D., 244.
 Shinn, Miss M. W., 17, 31, 32, 158,
 159, 189, 191, 192, 261, 264.
 Sigismund, B., 17.
- Simon, Th., 42.
 Sisson, Miss G., 138.
 Smedley, F. W., 287.
 Smith, Miss T. L., 35, 117, 118, 218,
 220.
 Snyder, Miss A. D., 173.
 Spencer, H., 126.
 Sully, J., 166, 190, 197, 221.
 Swift, E. J., 14, 229.
- Tanner, Miss Amy E., 197, 262.
 Tarde, G., 241.
 Terman, L. M., 44, 235.
 Thorndike, E. L., 35, 36, 85, 118,
 123, 263 ff., 275, 293 ff.
 Tiedemann, D., 17.
 Titchener, E. B., 40, 289.
 Town, Miss C. H., 175 ff.
 Tracy, F., 156, 157, 190.
 Travis, T., 227, 229, 237.
 Tyler, J. M., 65.
- Van Liew, C. C., 19.
- Walker, C. E., 56.
 Walter, H. E., 56.
 Weismann, A., 74, 75, 79, 81.
 West, Mrs. M., 69.
 Whipple, G. M., 40, 177.
 Winch, W. H., 41.
 Witmer, L., 34.
 Wolff, Miss F. E., 168.
 Woods, F. A., 83 ff., 232.
- Ziehen, Th., 284.

DATE OF ISSUE

This book must be returned
within 3, 7, 14 days of its issue. A
fine of ONE ANNA per day will
be charged if the book is overdue.



PRESCRIBED AS A

TEXT BOOK

Not to be issued without permission.

LIBRARIAN.